

**Ministry of Agriculture  
Republic of Peru**

**THE PREPARATORY STUDY  
ON  
PROJECT OF THE PROTECTION OF  
FLOOD PLAIN AND VULNERABLE RURAL  
POPULATION AGAINST FLOOD IN THE  
REPUBLIC OF PERU**

**FINAL REPORT  
MAINREPORT  
I-4 PROJECT REPORT (PISCO RIVER)**

**March 2013**

**JAPAN INTERNATIONAL COOPERATION AGENCY  
(JICA)**

**YACHIYO ENGINEERING CO., LTD.  
NIPPON KOEI CO., LTD.  
NIPPON KOEI LATIN AMERICA –  
CARIBBEAN Co., LTD.**

GE
CR (4)
13-090



## Composition of Final Report

### I. Feasibility Study Report

I-1 Program Report

I-2 Project Report (Cañete River)

I-3 Project Report (Chincha River)

**I-4 Project Report (Pisco River) (This Report)**

I-5 Project Report (Majes-Camana River )

I-6 Supporting Report

Annex – 1 Metrology /Hydrology /Run-off Analysis

Annex – 2 Inundation Analysis

Annex – 3 River Bed Fluctuation Analysis

Annex – 4 Flood Control Plan

Annex – 5 Forecasting and Warning System in Chira River

Annex – 6 Sediment Control

Annex – 7 Afforestation and Vegetation Recovery Plan

Annex – 8 Plan and Design of Facilities

Annex – 9 Construction Planning and Cost Estimate

Annex – 10 Socio-economy and Economic Evaluation

Annex – 11 Environmental and Social Considerations/ Gender

Annex – 12 Technical Assistance

Annex – 13 Stakeholders Meetings

Annex – 14 Implementation Program of Japanese Yen Loan Project

Annex – 15 Drawings

I-7 Data Book

### II. Pre- Feasibility Study Report

II-1 Program Report

II-2 Project Report (Chira River)

II-3 Project Report (Cañete River)

II-4 Project Report (Chincha River)

II-5 Project Report (Pisco River)

II-6 Project Report (Yauca River)

II-7 Project Report (Majes-Camana River River)





Study Area Map



## Abbreviation

Abbreviation	Official Name or meaning
ANA	Autoridad Nacional del Agua(Water National Authority )
ALA	Autoridad Local del Agua( Water Local Authority)
B/C	Cost-Benefit Ratio(Cost-Benefit relation)
GDP(PBI)	Producto Bruto Interno(PBI)( Gross Domestic Product)
GIS	Sistema de información geográfica (Geographic Information System)
DGAA	Dirección General de Asuntos Ambientales(Environmental Affairs General Direction)
DGFFS	Dirección General de Forestal y de Fauna Silvestre (Forestry and Fauna General Direction)
DGIH	Dirección General de Infraestructura Hidráulica (Hydraulic Infrastructure General Direction)
DGPI(previous DGPM)	Dirección General de Política de Inversiones (Investment Policy General Direction), (Dirección General de Programación Multianual del Sector Público )(Public Sector Multiannual Program General Direction)
DGETP(previous DNEP)	Dirección General de Endeudamiento y Tesoro Público (Public Indebtedness National Direction), Dirección Nacional de Endeudamiento Público
DRA	Dirección Regional de Agricultura (Agriculture Regional Direction)
EIA	Estudio de impacto ambiental (Environmental Impact Assessment - EIA)
FAO	Organización de las Naciones Unidas para la Agricultura y la Alimentación (Food and Agriculture Organization of the United Nations)
F/S	Estudio de Factibilidad (Feasibility Study)
GORE	Gobiernos Regionales (Regional Governments)
HEC-HMS	Sistema de Modelado Hidrológico del Centro de Ingeniería Hidrológica (Hydrologic Model System from the Hydrology Engineer Center)
HEC-RAS	Sistema de Análisis de Ríos del Centro de Ingeniería Hidrológica (Hydrologic Engineering Centers River Analysis System)
IGN	Instituto Geográfico Nacional (National Geographic Institute)
IGV	Impuesto General a Ventas (TAX)
INDECI	Instituto Nacional de Defensa Civil (Civil defense National Institute)
INEI	Instituto Nacional de Estadística (Statistics National Institute)
INGEMMET	Instituto Nacional Geológico Minero Metalúrgico (Metallurgic Mining Geologic National Institute)
INRENA	Instituto Nacional de Recursos Naturales (Natural Resources National Institute)
IRR	Tasa Interna de Retorno (Internal Rate of Return - IRR)
JICA	Agencia de Cooperación Internacional del Japón (Japan International Cooperation Agency)
JNUDRP	Junta Nacional de Usuarios de los Distritos de Riego del Perú (Peruvian Irrigation District Users National Board)
L/A	Acuerdo de Préstamo (Loan Agreement)
MEF	Ministerio de Economía y Finanzas (Economy and Finance Ministry)
MINAG	Ministerio de Agricultura (Agriculture Ministry)

M/M	Minuta de Discusiones (Minutes of Meeting)
NPV	VAN (Valor Actual Neto) (NET PRESENT VALUE)
O&M	Operación y mantenimiento (Operation and maintenance)
OGA	Oficina General de Administración (Administration General Office)
ONERRN	Oficina Nacional de Evaluación de Recursos Naturales (Natural Resources Assessment National Office)
OPI	Oficina de Programación e Inversiones (Programming and Investment Office)
PE	Proyecto Especial Chira-Piura (Chira-Piura Special Project)
PES	PSA (Pago por Servicios ambientales) (Payment for Environmental Services)
PERFIL	Estudio del Perfil (Profile Study)
Pre F/S	Estudio de prefactibilidad (Pre-feasibility Study)
PERPEC	Programa de Encauzamiento de Ríos y protección de Estructura de Captación (River Channeling and Protection of Collection Structures Program)
PRONAMACHIS	Programa Nacional de Manejo de Cuencas Hidrográficas y Conservación de Suelos (Water Basins Management and Soil Conservation National Program)
PSI	Programa Sub Sectorial de irrigaciones (Sub-Sectorial Irrigation Program)
SCF	Factor de conversión estándar (Standard Conversion Factor)
SENAMHI	Servicio Nacional de Meteorología y Hidrología (Meteorology and Hydrology National Service)
SNIP	Sistema Nacional de Inversión Pública (Public Investment National System)
UE	Unidad Ejectora(Execution Units)
UF	Unidades Formuladoras (Formulator Units)
VALLE	Llanura aluvial, llanura de valle (Alluvial Plain, Valley Plain)
VAT	Impuesto al valor agregado (Value added tax)



**THE PREPARATORY STUDY**  
**ON**  
**PROJECT OF THE PROTECTION OF FLOOD PLAIN AND VULNERABLE RURAL**  
**POPULATION AGAINST FLOODS IN THE REPUBLIC OF PERU**  
**FINAL REPORT**  
**I-4 MAIN REPORT**  
**PROJECT REPORT**  
**(PISCO RIVER)**

**Table of Contents**

**Location Map**

**Abbreviation**

1. EXECUTIVE SUMMARY .....	1-1
1.1 Project Name .....	1-1
1.2 Project's Objective .....	1-1
1.3 Supply and Demand Balance.....	1-1
1.4 Technical Proposal .....	1-2
1.4.1 Structural Measures .....	1-2
1.4.2 Non-Structural Measures .....	1-3
1.4.3 Technical Support.....	1-4
1.5 Costs .....	1-4
1.6 Social Assessment .....	1-5
1.7 Sustainability Analysis .....	1-6
1.8 Environmental Impact .....	1-7
1.9 Institutions and Management.....	1-8
1.10 Execution Plan.....	1-9
1.11 Financial Planning.....	1-10
1.12 Conclusion and Recommendation .....	1-11
1.12.1 Conclusion .....	1-11
1.12.2 Recommendation .....	1-11
1.13 Logical Framework.....	1-12
1.14 Middle and Long Term Plans .....	1-13
2. GENERAL ASPECTS .....	2-1
2.1 Name of the Project .....	2-1
2.2 Formulator and Executor Units .....	2-1
2.3 Involved Entities and Beneficiaries Participation.....	2-1
2.4 Framework.....	2-4
2.4.1 Background.....	2-4
2.4.2 Laws, Regulations, Policies and Guidelines related to the Program .....	2-7

3. IDENTIFICATION .....	3-1
3.1 Diagnosis of the Current Situation .....	3-1
3.1.1 Nature .....	3-1
3.1.2 Socio-Economic Conditions of the Study Area .....	3-2
3.1.3 Agriculture .....	3-7
3.1.4 Infrastructure.....	3-10
3.1.5 Real Flood Damages.....	3-13
3.1.6 Results on the Visits to Study Sites.....	3-14
3.1.7 Current Situation of Vegetation and Reforestation .....	3-20
3.1.8 Current Situation of the Soil Erosion.....	3-24
3.1.9 Run-Off Analysis .....	3-34
3.1.10 Analysis of Inundation .....	3-57
3.2 Definition of Problem and Causes.....	3-63
3.2.1 Problems of Flood Control Measures in the Study Area .....	3-63
3.2.2 Problem Causes .....	3-63
3.2.3 Problem Effects.....	3-64
3.2.4 Causes and Effects Diagram .....	3-64
3.3 Objective of the Project .....	3-66
3.3.1 Solving Measures for the Main Problem .....	3-66
3.3.2 Expected Impacts for theMmain’s Objective Fulfillment.....	3-66
3.3.3 Measures - Objectives – Impacts Diagram .....	3-67
4. FORMULATION AND EVALUATION .....	4-1
4.1 Definition of the Assessment Horizon of the Project .....	4-1
4.2 4.2 Supply and Demand Analysis.....	4-1
4.3 Technical Planning .....	4-3
4.3.1 Structural Measures .....	4-3
4.3.2 Nonstructural Measures .....	4-18
4.3.3 Technical Assistance .....	4-27
4.4 Costs .....	4-32
4.4.1 Cost Estimate (at Private Prices) .....	4-32
4.4.2 Cost Estimate (at social price) .....	4-51
4.5 Social Assessment .....	4-53
4.5.1 Private Prices Costs .....	4-53
4.5.2 Social Prices Costs.....	4-60
4.5.3 Social assessment conclusions.....	4-61
4.6 Sensitivity Analysis .....	4-62
4.7 Risk Analysis .....	4-63
4.8 Sustainability Analysis .....	4-65
4.9 Environmental Impact .....	4-67
4.9.1 Procedure of Environmental Impact Assessment .....	4-67

4.9.2 Methodology .....	4-69
4.9.3 Identification, Description and Social Environmental Assessment .....	4-70
4.9.4 Socio-Environmental Management Plans.....	4-72
4.9.5 Monitoring and Control Plan .....	4-74
4.9.6 Cost for the Environmental Impact Management.....	4-77
4.9.7 Conclusions and Recommendations .....	4-77
4.10 Institutions and Administration .....	4-78
4.11 Execution Plan.....	4-84
4.12 Financial Plan .....	4-88
4.13 Logical framework of the Eventually Selected Option .....	4-89
4.14 Baseline for Impact Assessment .....	4-90
4.15 Middle and Long Term Plan .....	4-91
4.15.1 Flood control General Plan .....	4-91
4.15.2 Reforestation and Recovery of Vegetation Plan .....	4-104
4.15.3 Sediment Control Plan .....	4-105
5. CONCLUSION AND RECOMMENDATION.....	5-1
5.1 Conclusion.....	5-1
5.2 Recommendation.....	5-1
5.2.1 Recommendation on Implementation of This Project .....	5-1
5.2.2 Recommendation for Future Flood Control Plan in Peru .....	5-5



## 1. EXECUTIVE SUMMARY

### 1.1 Project Name

“Protection program for valleys and rural communities vulnerable to floods Implementation of prevention measures to control overflows and floods of Pisco River, Ica department.”

### 1.2 Project’s Objective

The ultimate impact that the project is design to achieve is to alleviate the vulnerability of valleys and the local community to flooding and boost local socioeconomic development.

### 1.3 Supply and Demand Balance

It has been calculated the theoretical water level in case of flow design flood based on the transversal lifting data of the river with an interval of 500m, in the Pisco River watershed, assuming a design flood flow equal to the flood flow with a return period of 50 years. Then, we determined the dike height as the sum of the design water level plus the dike’s free board.

This is the required height of the dike to control the damages caused by design floods and is the indicator of the demand of the local community.

The height of the existing dike or current ground height is the required height to control the current flood damages, and is the indicator of the current offer.

The difference between the dike design height (demand) and the height of the embankment or current ground height is the difference or gap between demand and supply.

Table 1.3-1 shows the average water levels floods, calculated with a return period of 50 years, of the required height of the dike (demand) to control the flow by adding the design water level plus the free board of the dike; from dike height or current ground height (supply), and the difference between these two (difference between demand and supply) of the river. Then, in Table 4.2-2 the values at each point are shown. The current height of the dike or the current ground height is greater than the required height of the dike, at certain points. In these, the difference between supply and demand is considered null.

**Table 1.3-1 Demand and supply analysis**

Watershed	Dike Height / current land (supply)		Theoretical water level with a return period of 50 years	Dike Freeboard	Required dike's height (demand)	Diff. demand/supply	
	Left bank	Right bank				Left bank	Right bank
	①	②				③	④
Pisco	219.72	217.26	214.82	1.00	215.82	0.63	0.76

## **1.4 Technical Proposal**

### **1.4 .1 Structural Measures**

Structural measures are a subject that must be analyzed in the flood control plan covering the entire watershed. The analysis results are presented in section 1.14 “medium and long term plan” This plan proposes the construction of dikes for flood control throughout the watershed. However, the case of Pisco River requires a large project investing at a extremely high cost, far beyond the budget for this Project, which makes this proposal it impractical. Therefore, assuming that the dikes to control floods throughout the whole basin will be constructed progressively over a medium and long term period. Here is where this study focused on the most urgent works, priority for flood control.

#### **(1) Design flood flow**

The Methodological Guide for Protection Projects and/or Flood Control in Agricultural or Urban Areas (Guia Metodologica para Proyectos de Proteccion y/o Control de Inundaciones en Áreas Agricolas o Urbanas, 3.1.1 Horizonte de Proyectos) prepared by the Public Sector Multi Annual Programming General Direction (DGPM) (present DGPI) of the Ministry of Economy and Finance (MEF) recommends a comparative analysis of different return periods: 25, 50 and 100 years for the urban area and 10, 25 and 50 years for rural and agricultural land.

Considering that the present Project is aimed at protecting the rural and agricultural land, the design flood flow is to be determined in a return period of 10 years to 50 years t in the mentioned Guide.

It was confirmed that the flood discharge with return period of 50 years in the basin is determined as design flood discharge and it is almost same as the past maximum observed discharge.

In Peru the flood protection works in the basins are developed almost nil, therefore it is not necessary to adopt the design discharge more than the past maximum discharge. However, the large disasters occurred in the past so that the design flood discharge with return period of 50 years, which is almost equal to the past maximum, is to be adopted considering to avoid the flood damage nearly equal to the damage occurred in the past .

The relation among flood discharge with different return period, damage caused by the floods and inundation areas is analyzed in the basin. The results are that the more the return periods of flood increase the more inundation area and damage amount increase in the basin, however the increase tendency of damage with project is more gentle compared with former two items, and the reduction of damage with project reaches to maximum in the case of the flood with return period of 50 years within the cases of flood with less return period of 50 years.

As described above, the adopted design flood discharge with return period of 50 years is almost same as the past maximum discharge and damage reduction amount in the adopted case becomes more than that of the flood discharges with less return period, and the result of social evaluation is also high.

## **(2) Selection of prioritized flood prevention works**

We applied the following five criteria for the selection of priority flood control works.

- Demand from the local community (based on historical flood damage)
- Lack of discharge capacity of river channel (including the sections affected by the scouring)
- Conditions of the adjacent area (conditions in urban areas, farmland, etc.).
- Conditions and area of inundation (type and extent of inundation according to inundation analysis)
- Social and environmental conditions (important local infrastructures)

Based on the river survey, field investigation, discharge capacity analysis of river channel, inundation analysis, and interviews to the local community (irrigation committee needs, local governments, historical flood damage, etc...) a comprehensive evaluation was made applying the five evaluation criteria listed above. After that we selected a total of six (6) critical points (with the highest score in the assessment) that require flood protection measures.

Concretely, since the river cross sectional survey was carried out every 500m interval and discharge capacity analysis and inundation analysis were performed based on the survey results, the integral assessment was also done for sections of 500 meters. This sections have been assessed in scales of 1 to 3 (0 point, 1 point and 2 points) and the sections of which score is more than 6 were selected as prioritized areas. The lowest limit (6 points) has been determined also taking into account the budget available for the Project in general

### **1.4.2 Non-Structural Measures**

#### **(1) Reforestation and vegetation recovery**

##### 1) Basic Policies

The reforestation plan and vegetation recovery that meets the objective of this project can be divided into: i) reforestation along river structures, and ii) reforestation in the upper watershed. The first has a direct effect on flood prevention expressing its impact in a short time, while the second one requires high cost and a long period for its implementation, as indicated later in the section 1.14 (2) "Reforestation plan and vegetation recovery", and also it is impractical to be implemented within the framework of this project. Therefore, this study focused on the first alternative.

##### 2) Reforestation along river structures

This alternative proposes planting trees along the river structures, including dikes and bank protection works.

- Objective: Reduce the impact of flooding of the river when an unexpected flood or by the presence of obstacles, using vegetation strips between the river and the objects to be protected.
- Methodology: Create vegetation stripes of a certain width land side of river structures.
- Execution of works: Plant vegetation with certain width in land side of the river structures (dikes, etc.).

- Maintenance after reforestation: Maintenance will be taken by irrigation committees under their own initiative.

The length and area of reforestation along river structures are 5.95 km, and 6.6ha respectively including the reforestation in the retarding basin in the Pisco basin.

## **(2) Sediment control plan**

The sediment control plan must be analyzed within the general plan of the watershed. The results of the analysis are presented in section 1.14 “Medium and long term plan (3) Sediment control”. To sum up, the sediment control plan for the entire watershed requires a high investment cost, which goes far beyond the budget of this project, which makes it impractical to adopt. So, the sediments control plan in this project was focused on the alluvial fan.

Fluctuation analysis of the river bed has showed that in Pisco rivers sediment accumulation has strong incidence. So, it is recommended to execute a sediment control plan in the alluvial fan for these rivers.

The set of priority works for flood control include a retarding basin at km 34.5 of Pisco River, which will have a retardation effect. This flood protection work will also be used to control sediments.

### **1.4.3 Technical Support**

Based on the technical proposals of structural and nonstructural measures, it is also intends to incorporate in this project technical assistance to strengthen the measures.

The objective of the technical assistance is to “improve the capacity and technical level of the local community, to manage risk to reduce flood damage in selected valleys.”

Technical assistance will cover the Pisco river watershed.

Aiming to train characteristics of the watershed, courses for one will be prepared. The beneficiaries are the representatives of the committees and irrigation groups from each watershed, governments employees (provincial and district), local community representatives, local people etc.

Qualified as participants in the training, people with ability to replicate and disseminate lessons learned in the courses to other community members, through meetings of the organizations to which they belong.

In order to carry out the technical assistance goal, the three activities propose the following:

- Bank protection activity and knowledge enhancement on agriculture and natural environment
- Community disaster prevention planning for flood damages
- Watershed (slope) management against fluvial sedimentation

## **1.5 Costs**

In the Table 1.5-1 the costs of this Project in Pisco watershed is shown. The cost of the watersheds is around 68.4 million soles.



**Table 1.5-1 project cost**

					(1000 soles)
Watershed	Construction Cost	Consultant Cost	Land Acquisition Cost	Management Cost of Implementation Agency	Total Cost
Pisco	59,027	7,164	353	2,454	68,998

## 1.6 Social Assessment

The objective of the social assessment in this study is to evaluate the efficiency of investments in the structural measures from the point of view of national economy. To do this, we determined the economic evaluation indicators (B/C relation, Net Present Value-NPV, and Internal return rate - IRR).

The benefits of the evaluation period were estimated, from the first 15 years since the start of the project. Because, from these 15 years, two are from the work execution period, the evaluation was conducted for the 13 years following the completion of works.

Below the social assessment results for this Project based on the above economic evaluation indicators are shown.

**Table 1.6-1 Social evaluation**

	流域 Basin	年平均被害軽減額 Average Annual Damage Reduction Amount	評価期間被害軽減額(15年) Damage Reduction Amount in Evaluation Period(15years)	事業費 Project Cost	維持管理費 Operation & Maintenance Cost	B/C Benefit and Cost Ratio	Net Present Value (NPV) Valor Actual Neto (VAN)	Internal Rate of Return (IRR) Tasa Interna de Retorno (TIR)
Private Price	Pisco	231,968,634	104,752,437	66,544,136	4,977,123	1.74	44,377,936	21%
Social Price	Pisco	237,897,809	107,429,935	55,430,191	4,230,554	2.13	57,079,434	27%

Regarding social prices costs, the project may show a positive economic impact in Pisco, the relation B/C will be over 1.0.

Next, the positive effects of the Project are shown, which are quite difficult to quantify in economic values:

- ① Contribution to local economic development to alleviate the fear to economic activities suspension and damages
- ② Contribution to increase local employment opportunities thanks to the local construction project
- ③ Strengthening the awareness of local people regarding damages from floods and other disasters
- ④ Contribution to increase from stable agricultural production income, relieving flood damage
- ⑤ Rise in farmland prices

From the results of the economic evaluation presented above, it is considered that this project will substantially contribute to the development of the local economy.

### 1.7 Sustainability Analysis

This project will be co-managed by the central government (through the DGIH), irrigation committees and regional governments, and the project cost will be covered with the respective contributions of the three parties. On the other hand, the operation and maintenance (O & M) of completed works is taken by the irrigation committees. Therefore, the sustainability of the project is depends on the profitability of the project and the ability of O & M of irrigation committees.

The profitability of the project is high enough as described in the clause 1.6 so that the sustainability of the project is guaranteed. In the Table 1.7-1 the budget data from last year of the irrigation commissions is shown.

**Table 1.7-1 Irrigation commission's budget**

Rivers	Annual Budget (Unit/ S)			
	2007	2008	2009	2010
Pisco	1,648,019.62	1,669,237.35	1,725,290.00	1,425,961.39

On the other hand the annual O/M cost required after implementation of the Project is as shown in the Table-1.7-2, of which detail is described in the clause 4.4.1. The percentage of O/M cost to the annual budget of irrigation committee in the basin and the annual flood damage reduction amount is also as shown in the same table.

The percentage of O/M cost to the annual budget of irrigation committee is 22.2% . And the percentage of O/M cost to the annual flood damage reduction amount is 2.1%, which is very low. Although the percentage of O/M cost to the annual budget is relatively high, the percentage of O/M cost to the yearly average damage reduction amount is very low. Since the benefit of agriculture increases due to the reduction of flood damage, it is possible enough that the irrigation committee will bear the O/M cost. The technical capacity of irrigation committee for O/M seems to be enough by the technical assistance of MINAG and regional government because the flood prevention facilities such as embankment, bank protection and weir are familiar structures to the committee

**Table 1.7-2 Percentage of O/M cost to annual budget and damage reduction amount**

Irrigation Committee	Annual Budget(1,000soles)	O/M Cost(1,000soles)	Percentage of O/M cost(%)	Average Yearly Damage Reduction(1,000soles)	Percentage of O/M cost(%)
	①	②	③=②/①	④	⑤=②/④
Pisco	1,725	383	22.2	17,844	2.1

## **1.8 Environmental Impact**

### **(1) Procedure of Environmental Impact Assessment**

Projects are categorized in three scales, based on the significance level of the negative and positive impacts, and each sector has an independent competence on this categorization. The Project holder should submit the Environmental Impact Statement (DIA, in Spanish) for all Projects under Category I. The project holder should prepare an EIA-sd or an EIA-d if the Project is categorized under Category II or III, respectively, to be granted the Environmental Certification from the relevant Ministry Directorate.

First, the Project holder applies for the Project classification, by submitting the Preliminary Environmental Assessment (PEA). The relevant sector assesses and categorizes the Project. The Project's PEA that is categorized under Category I becomes an EID, and those Projects categorized under Category II or III should prepare an EIA-sd or EIA-d, as applicable.

The preliminary environmental assessment (EAP) for Pisco river was carried out between December 2010 and January 2011 and by a consulting firm registered in the Ministry of Agriculture (CIDES Ingenieros S.A.). EAP for Pisco was submitted to DGIH January 25, 2011 by JICA Study Team and from DGIH to DGAA July 19, 2011.

DGAA examined EAP and issued approval letter of Category I. Therefore, no further environmental impact assessment is required for Pisco.

### **(2) Results of Environmental Impact Assessment**

The procedures to review and evaluate the impact of the natural and social environment of the Project are the following. First, we reviewed the implementation schedule of the construction of river structures, and proceeded to develop the Leopold matrix.

The impact at environmental level (natural, biological and social environment) was evaluated and at Project level (construction and maintenance stage). The quantitative levels were determined by quantifying the environmental impact in terms of impact to nature, manifestation possibility, magnitude (intensity, reach, duration and reversibility).

The EAP showed that the environmental impact would be manifested by the implementation of this project in the construction and maintenance stages, mostly, it is not very noticeable, and if it were, it can be prevented or mitigated by appropriately implementing the management plan environmental impact.

On the other hand, the positive impact is very noticeable in the maintenance stage, which manifests at socioeconomic and environmental level, specifically, in greater security and reduced vulnerability, improved life quality and land use.

### 1.9 Institutions and Management

The institutions and its administration in the investment stage and in the operation and maintenance stage after the investment are as shown in the Figures 1.9-1 and 1.9-2.

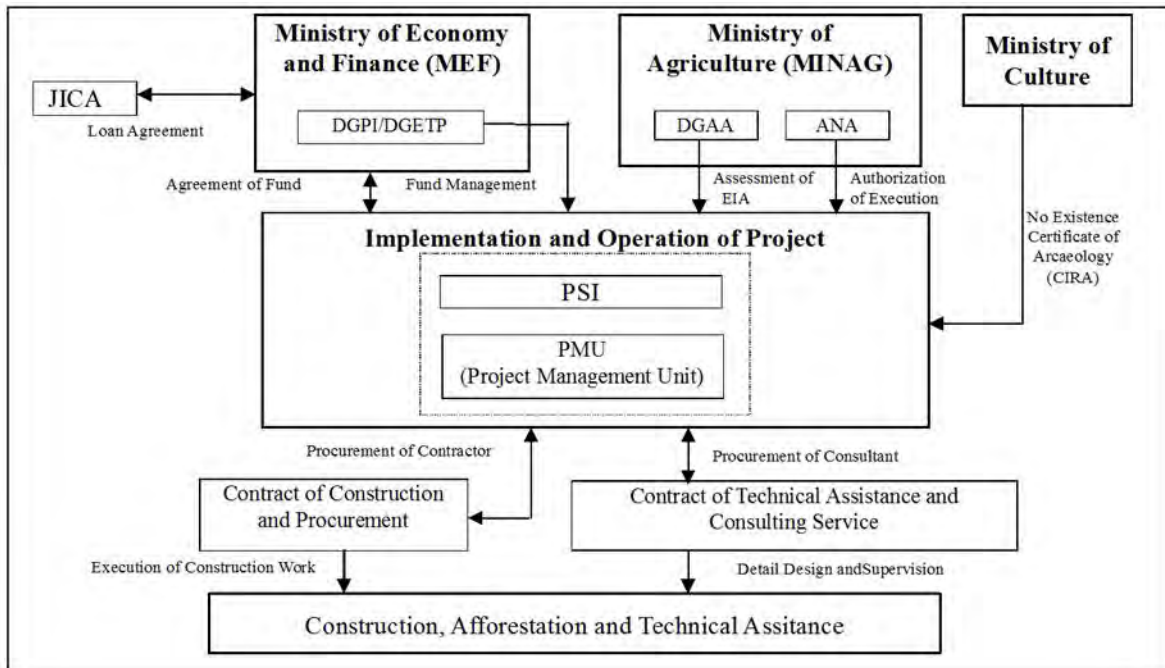

Figure 1.9-1 Related agencies in implementation stage of project

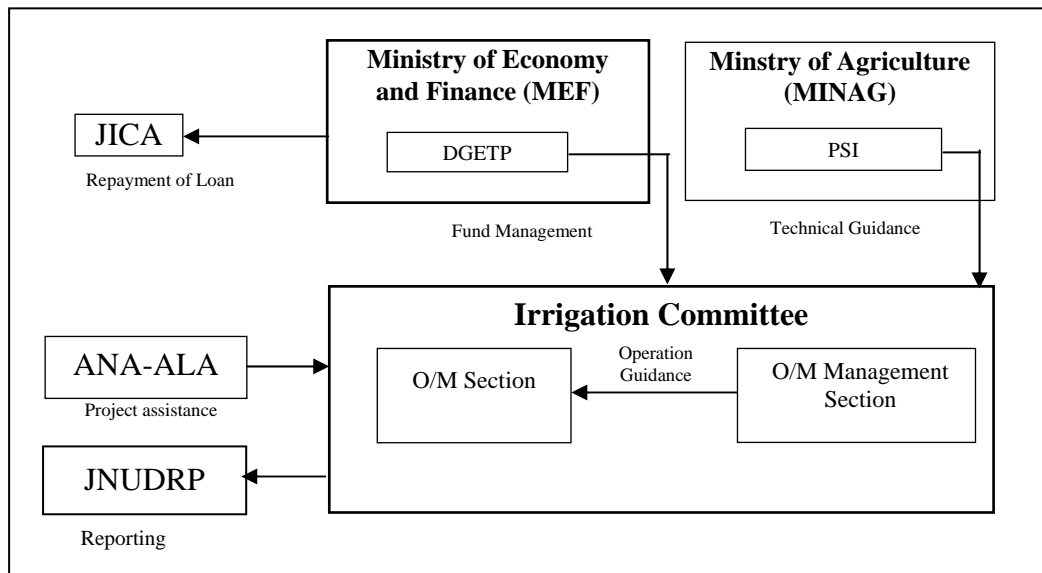
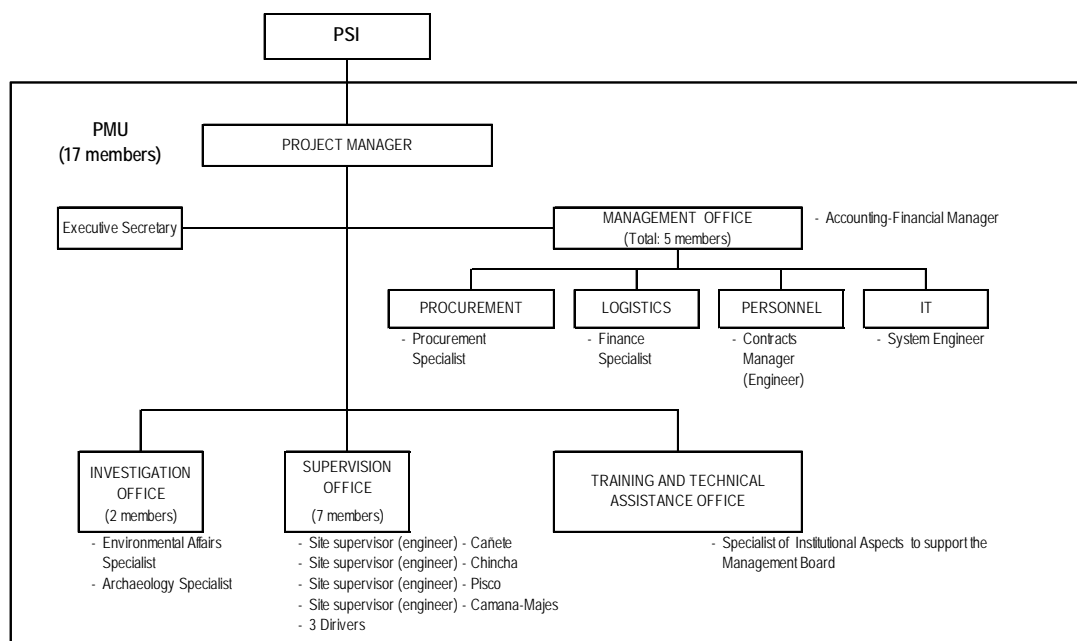

Figure 1.9-2 Related agencies in operation stage of project

The Project Management Unit (PMU) is to be organized under the Irrigation Infrastructure Direction of PSI, of which organization is as shown in the Figure-1.9-3 and 13 professionals are arranged. The operation cost of PMU is estimated as million soles.



Note: ( ) shows number of personnel

**Figure-1.9-3 Organization of PMU**

### 1.10 Execution Plan

Table 1.10-1 presents the Project execution plan.

**Table 1.10-1 Execution plan**

Item	2010			2011			2012			2013			2014			2015			2016			2017			2018			Months
	3	6	9	3	6	9	3	6	9	3	6	9	3	6	9	3	6	9	3	6	9	3	6	9	3	6	9	
1 Profile Study/SNIP Appraisal	Study						Appraisal																		28			
2 Feasibility Study/SNIP Appraisal				Study			Appraisal																		27			
3 Loan Appraisal										Appraisal															6			
4 Selection of Consultant													Selection												10			
5 Project Management Unit																PMU									45			
6 Consulting Services																Consulting									45			
1) Detailed Design																Design									6			
2) Tender Preparation, Assistance																Tender									15			
3) Supervision																			Supervision						24			
7 Selection of Contractor, Contract																Selection									15			
8 Implementation																			Implementation									
1) Structural Measures																			Structural						24			
2) Vegetation																			Vegetation						24			
3) Disaster Education/Capacity Building																			Education						24			
4) Land Acquisition																Acquisition									27			
9 Completion/Inauguration																						Completion			-			

#### 1) Employment of Consultants

The employment of consultant is to be made according the following itmes:

- ① The consultants should be active in international market and have enough qualification and experience.
- ② The consultants are to have efficiency, transparency and non-discrimination among eligible consultants

- ③ The selection procedure should be taken in accordance with the stipulation in the Loan Agreement and the guideline for the Employment of Consultants under Japanese ODA Loans prepared by JICA

2) Procurement of Contractor

The procurement of contractors is to be made according to the following items:

- ① The procurement of contractors is to be made using due attention to considerations of economy, efficiency, transparency and non-discrimination among eligible bidders.
- ② The procurement procedure should be taken in accordance with the stipulation in the Loan Agreement and the guideline for the Employment of Consultants under Japanese ODA Loans prepared by JICA
- ③ The International Competitive Bidding: ICB is to be applied.
- ④ The pre-qualification (PQ) of bidders is to be applied in order to confirm the technical and financial capability of bidders. The following items are to be considered in PQ: a) experience of and past performance on similar contracts, b) capabilities with respect to personnel, equipment and plant, c) financial position.

### 1.11 Financial Planning

This Project will be implemented by the central government, local government and irrigation committee. The cost sharing ratio among central government, local governments and irrigation committees is provisionally assumed to be 80%, 15% and 5% respectively. The final cost sharing ratio among stakeholders shall be determined through the discussions among them as soon as possible.

**Table 1.11-1 Financial planning in implementation of project**

(thousand soles)

	Item		Amount	Remarks
1	Project cost	①	239,474	
2	Yen loan	②	64,750	25millionUS\$x2.59
	Counter fund	③	174,724	①-②
3	Central government	④	139,779	③x80%
4	regional government	⑤	26,209	③x15%
	(1) Lima (canete)	⑥	3,355	⑤x12.8%(Ratio of Project Cost)
	(2) Ica (Chincha)	⑦	5,347	⑤x20.4%(Ratio of Project Cost)
	(Pisco)	⑧	7,548	⑤x28.8%(Ratio of Project Cost)
	Subtotal	⑨	12,895	⑦+⑧
	(3) Arequipa (Majes-Camana)	⑩	9,959	⑤x38.0%(Ratio of Project Cost)
5	Irrigation committee	⑪	8,736	③x5%
	(1) Canate	⑫	1,118	⑪x12.8%(Ratio of Project Cost)
	(2) Chincha	⑬	1,782	⑪x20.4%(Ratio of Project Cost)
	(3) Pisco	⑭	2,516	⑪x28.8%(Ratio of Project Cost)
	(4) Majes-Camana	⑮	3,320	⑪x38.0%(Ratio of Project Cost)

Note) 1 US \$ = 83,6 yen = 2,59 soles, 1 sol = 32,3 yen

## **1.12 Conclusion and Recommendation**

### **1.12.1 Conclusion**

The flood prevention facilities selected finally in this Project are safe in structural, and have high viability and give scarcely impact to the environment. It is concluded that the Project should be implemented as soon as possible so that the high vulnerability against flood in valleys (Valles) and rural communities could be reduced and the social economic development will be promoted in the Project area.

### **1.12.2 Recommendation**

Based on the knowledge and experience obtained from this Study, the following recommendations are presented on the implementation of this Project and the future flood control measures in Peru. For further detail refer to the main text 5.2.2.

#### **(1) Recommendation on Implementation of this Project**

- 1) Problems to be solved at present
  - \* Sharing ratio of Project cost among the central government(MINAG), the local governments and Irrigation committees in each basin
  - \* Negotiation of land acquisition and compensation with local people
  - \* Confirmation of implementation agency of the Project
  - \* Acquisition of CIRA (Certificación de Inexistente de Restos Arqueológicos)
  - \* Technical and economic assistance for the maintenance performed by irrigation committees by MINAG and local government
- 2) Structural measures
  - \* Basic policy of flood control
  - \* Problems for flood control planning in Pisco river
  - \* Problems in design and construction work
    - Construction work period is to be 9 months from April to December considering transition period to dry season from May to November
    - Stability of embankment
    - Requirement of stability analysis and infiltration analysis in the detail design stage
    - Method of compaction of embankment and supervision
    - Reduction of bank protection cost which occupies 80% of construction cost
    - Balance of embankment volume and excavation volume
- 3) Non-structural measures
  - \* Necessity of reforestation such as i) Short term plan and ii) Long term plan
  - \* Sediment control and riverbed fluctuation
    - Sediment control facility plan and soft counter measures
    - Riverbed fluctuation and necessity of monitoring
- 4) Disaster prevention education/capacity development

- \* Soft counter measures for reduction of flood damage
- \* Promotion of community disaster prevention

**(2) Recommendation for future flood control plan in Peru**

- 1) Preparation of comprehensive mater pan for flood control
- 2) Establishment of implementation agency for integral flood control project
- 3) Execution of strict river management
- 4) Establishment of nationwide network of rainfall observation stations and discharge observation stations

**1.13 Logical Framework**

Table 1.13-1 presents the logical framework of the final selected alternative.

**Table 1.13-1 Logical framework of the final selected alternative**

Narrative Summary	Verifying Indicators	Verifying Indicators Media	Preliminary Conditions
<b>Superior Goal</b>			
Promote socioeconomic local development and contribute in communities' social welfare.	Improve local productivity, generate more jobs, increase population's income and reduce poverty index	Published statistic data	Socio-economic and policy stability
<b>Objectives</b>			
Relief the high vulnerability of valleys and local continuity to floods	Types, quantity and distribution of flood control works, population and beneficiaries areas	Monitoring annual calendar works and financial plan, budget execution control	Ensure the necessary budget, active intervention from central and regional governments, municipalities, irrigation communities, local population, etc.
<b>Expected results</b>			
Reduction of number and flooded areas, functional improvement of intakes, irrigation channels protection, bank erosion control	Number of areas and flooded areas, water intake flow variation, bank erosion progress	Site visits, review of the flood control plan and flood control works reports and periodic monitoring of local inhabitants	Maintenance monitoring by regional governments, municipalities and local community, provide timely information to the superior organisms
<b>Activities</b>			
Component A: Structural Measures	Dikes rehabilitation, intake and margin protection works construction of 23 works, including dike's safety	Detailed design review, works reports, executed expenses	Ensure the works budget, detailed design/works execution/good quality works supervision
Component B: Non-Structural Measures (Reforestation and vegetation recovery)	Reforested area, coastal forest area	Works advance reports, periodic monitor by local community	Consultants support, NGO's, local community, gathering and cooperation of lower watershed community



Component C: Disaster prevention and capabilities development education	Number of seminars, trainings, workshops, etc	Progress reports, local governments and community monitoring	Predisposition of the parties to participate, consultants and NGO's assessments
Project's execution management			
Project's management	Detailed design, work start order, work operation and maintenance supervision	Design plans, work's execution plans, costs estimation, works specifications, works management reports and maintenance manuals	High level consultants and contractors selection, beneficiaries population participation in operation and maintenance

### 1.14 Middle and Long Term Plans

While it is true that due to the limited budget available for the Project, this study is focused mainly on the flood control measures analysis that must be implemented urgently. It is considered necessary to timely implement other necessary measures within a long term. In this section we will discuss the medium and long term plans.

#### (1) flood control general plan

There are several ways to control floods in the entire watershed, for example, the building of dams, retarding basin, dikes or a combination of these. The options to build dams or retarding basin are not viable because in order to answer to a flood flow with a return period of 50 years, enormous works would be necessary to be built. So, the study was focused here on dikes' construction because it was the most viable option.

Flood water level was calculated in the watershed adopting a designed flood flow with a return period of 50 years. At this water level, freeboard was added in order to determine the required dikes height. After, sections of the rivers where the dikes or ground did not reach the required height were identified. These sections, altogether, add up to approx.34km. Also, from maintaining these works, annually a dragged of the rivers has to be done in the sections where, according to the bed fluctuation analysis the sediment gathering is elevating the bed's height. The volume of sediments that shall be eliminated annually was determined in approximately 12,000 m<sup>3</sup>.

In Tables 1.14-1 and 1.14-2 the flood control general plan project cost is shown as well as the social assessment results in terms of private and social costs.

**Table 1.14-1 Project cost and social assessment of the general flood control plan  
(private prices costs)**

流域名 Basin	年平均被害軽減額 Annual Average Damage Reduction	評価期間被害 軽減額(15年) Damage Reduction in Evaluation Period(15years)	事業費 Project Cost	維持管理費 O&M Cost	B/C Cost Benefit Ratio	NPV Net Present Value	IRR(%) Internal Return of Rate
Pisco	241,380,602	109,002,695	110,779,465	9,420,215	1.08	7,808,090	11%

**Table 1.14-2 Project cost and social assessment of the general flood control plan  
(social prices costs)**

流域名 Basin	年平均被害軽減額 Annual Average Damage Reduction	評価期間被害軽減額(15年) Damage Reduction in Evaluation Period(15years)	事業費 Project Cost	維持管理費 O&M Cost	B/C Cost Benefit Ratio	NPV Net Present Value	IRR(%) Internal Return of Rate
Pisco	249,965,955	112,879,671	89,066,690	7,573,853	1.39	31,519,208	16%

In case of executing flood control works in the watershed, the works is economically viable, however the Projects' cost would elevate to 110.8 million soles, which is a huge amount for this project.

### (2) Reforestation plan and vegetation recovery

The forestry option was analyzed, in a long term basis, to cover every area that requires being covered with vegetation in the upper watershed. The objective is improving this areas' infiltration capacity, reduce of surface water and increase semi-underground and underground water. So, the flood maximum flow will be decreased, also it could be possible to increase the water reserve in the mountain areas and prevent and soothe floods. The areas to be reforested will be the afforested areas or where the forest mass in the water infiltration areas has been lost.

In Table 1.14-3 the area to be afforested and the project's cost for the watershed is shown. These were calculated based on forestry plan of Chincha River (refer to Annex-7 Afforestation and Vegetation Recovery Plan, 3.2 Long Term Plan). The total surface would be approximately 54,000hectares and in order to forest them the required time would be from 17 years and 145.6 million soles. To sum up, the Project has to cover an extensive area, with an investment of much time and at a high cost.

**Table 1.14-3 General plan for forestry on upper stream watersheds**

Watershed	Forestry Area (ha)	Required Period for the project (years)	Required Budget (1,000soles)
Pisco	53,938	17	145,586

### (3) sediment control plan

As long term sediment control plan, it is recommended to perform necessary works on the upper watershed. These works will mainly consist of dams and bank protection. In Table 1.14-4 the estimate work cost is shown. There are two costs, one for executing works in the entire watershed and another one for executing works only in prioritized areas based on the slope of river channel (refer to Annex-6, Sediment Control , Table-1.5.1).

All the chosen watersheds for this Project are big. So, if bank protection works and sediment control dams want to be built, not only the works' cost would elevate but also a very long period of

investment would have to be done in the watershed. This means that its positive impact will be seen in a long time.

**Table 1.14-4 Projects' general costs of the sediment control installations  
upstream the watershed**

Watersheds	Areas	Bank Protection		Bands		Dams		Works direct cost (total)	Project Cost (in millions de s/.)
		Qty. (km)	Works direct costs (million s/.)	Qty. (No.)	Works direct costs (million s/.)	Qty. (No.)	Works direct costs (million s/.)		
Pisco	Totally	269	S/.287	27	S/.1	178	S/.209	S/.497	S/.935
	Prioritized areas	269	S/.287	27	S/.1	106	S/.126	S/.414	S/.779



## **2. GENERAL ASPECTS**

### **2.1 Name of the Project**

“Protection program for valleys and rural communities vulnerable to floods Implementation of prevention measures to control overflows and floods of Pisco River, Ica department”

### **2.2 Formulator and Executor Units**

#### **(1) Formulator Unit (UF)**

Name: Hydraulic Infrastructure General Direction, Agriculture Ministry  
Responsible: Gustavo Adolfo Canales Kriljenko  
General Director of the Water Infrastructure General Direction  
Address: Av. Guillermo Prescott No. 490, San Isidro – Perú  
Phone: (511) 6148100, (511) 6148101  
Email: gcanales@minag.gob.pe

#### **(2) Executor Unit (UE)**

Name: Sub-sectorial Irrigation Program, Agriculture Ministry  
Manager: Jorge Zúñiga Morgan  
Executive Director  
Address: Jr. Emilio Fernandez N° 130 Santa Beatriz, Lima-Peru  
Phone: (511) 4244488  
Email: postmast@psi.gob.pe

### **2.3 Involved Entities and Beneficiaries Participation**

Here are the institutions and entities involved in this project, as well as beneficiaries.

#### **(1) Agriculture Ministry (MINAG)**

MINAG, as manager of natural resources of watersheds promotes agricultural development in each of them and is responsible of maintaining the economical, social and environmental to benefit agricultural development.

To accomplish effectively and efficiently this objective, the MINAG has been working since 1999 in the River Channeling and Collection Structures Protection Program (PERPEC). The river disaster prevention programs that are been carried out by regional governments are funded with PERPEC resources.

##### **1) General Administration Office (OGA)**

- Manages and executes the program’s budget
- Establishes the preparation of management guides and financial affairs

2) Hydraulic Infrastructure general Direction (DGIH)

- Performs the study, control and implementation of the investment program
- Develops general guidelines of the program together with OPI

3) Planning and Investment Office (OPI) present Planning and Budgetary Office (OPP)

- Conducts the preliminary assessment of the investment program
- Assumes the program's management and the execution of the program's budget
- Plans the preparation of management guides and financial affairs

4) Irrigation Sub-Sectorial Program (PSI)

- Carries-out the investment program approved by OPI and DGPI

**(2) Economy and Finance Ministry (MEF)**

Investment Policy General Direction (DGPI; previous DGPM) is in charge of approving public investment works according to procedures under the Public Investment National System (SNIP) to assess the relevance and feasibility of processing the disbursement request of the national budget and the loan from JICA.

**(3) Japan's International Cooperation Agency (JICA)**

It is a Japanese government institution with the objective of contributing in the socioeconomic development of developing countries through international cooperation. JICA has extended financial assistance to carry out profile and feasibility studies of this Project.

**(4) Regional Governments (GORE)**

Regional governments assume the promotion of integrated and sustainable regional development following the national and regional plans and programs, trying to increase public and private investment, generating employment opportunities, protecting citizens rights and ensuring equal opportunities.

The regional governments' participation with their possible financial support is a very important factor to ensure the Project's sustainability.

**(5) Irrigation Commission**

Currently there are 19 irrigation commissions in the Pisco River Watershed. These have expressed a strong desire for the starting of works because these will help constructing dikes, protecting margins, repairing water intakes, etc. These commissions are currently suffering major damages due to rivers flooding. Next, a brief overview of the Pisco River Watershed is described (for more details, see Section 3.1.3). Currently, the operation and maintenance of dikes, margin protection works, irrigation intakes and channels linked to agricultural land and irrigation systems in the Watershed, are mainly made by irrigation commissions and their members, with the assistance of local governments.

Number of irrigation blocks:	11
Number of Irrigation Commissions:	19
Irrigated Area:	22,468ha
Beneficiaries:	3,774 producers

#### **(6) Meteorology and Hydrology National Service (SENAMHI)**

It is an agency from the Environment Ministry responsible for all activities related to meteorology, hydrology, environment and agricultural meteorology. Take part in global level monitoring, contributing to sustainable development, security and national welfare, and gathering information and data from meteorological stations and hydrological observation.

#### **(7) Civil Defense National Institute (INDECI)**

INDECI is the main agency and coordinator of SINAGERD (Sistema Nacional de Gestioh del Riesgo de Desastiv, established in May 2011. It is responsible for organizing and coordinating the community, elaborating plans and developing disaster risk's management processes. Its objective is to prevent or alleviate human life loss due to natural and human disasters and prevent destruction of property and the environment.

#### **(8) Water National Authority (ANA)**

It is the highest technical regulating authority in charge of promoting, monitoring and controlling politics, plans, programs and regulations regarding sustainable use of water resources nationwide.

Its functions include sustainable management of these resources, as well as improving the technical and legal framework on monitoring and assessment of water supply operations in each region.

Along with maintaining and promoting a sustainable use of water resources, it is also responsible for conducting the necessary studies and developing main maintenance plans, national and international economic and technical cooperation programs.

#### **(9) Agriculture Regional Directorates (DRA's)**

Agricultural regional addresses fulfill the following functions under the respective regional government:

- 1) Develop, approve, assess, implement, control and manage national agriculture policies, sectorial plans as well as regional plans and policies proposed by municipalities
- 2) Control agriculture activities and services fitting them to related policies and regulations, as well as on the regional potential
- 3) Participate in the sustainable management of water resources agreeing with the watershed's general framework, as well as the policies of the Water National Authority (ANA)
- 4) Promote the restructure of areas, market development, export and agricultural and agro-industrial products consumption

5) Promote the management of: irrigation, construction and irrigation repair programs, as well as the proper management and water resources and soil conservation

## **2.4 Framework**

### **2.4.1 Background**

#### **(1) Study background**

The Republic of Peru (hereinafter “Peru”) is a country with high risk of natural disasters such as earthquakes, Tsunamis, etc. Among these natural disasters there are also floods. In particular, El Niño takes place with an interval of several years and has caused major flood of rivers and landslides in different parts of the country. The most serious disaster in recent years due to El Niño occurred in the rainy season of 1982-1983 and 1997-1998. In particular, the period of 1997-1998, the floods, landslides, among others left loss of 3,500 million of dollars nationwide. The latest floods in late January 2010, nearby Machupicchu World Heritage Site, due to heavy rains interrupted railway and roads traffic, leaving almost 2,000 people isolated. In Majes-Camana river the flood with discharge of over 1,100m<sup>3</sup>/sec (equivalent to about 10years probability flood) occurred at the midnight in February 13, 2012 causing flood disaster in the project area. The total area of inundation was 1,085 ha, the total length of 780m of dike was destroyed , and the main irrigation canal of 800m and secondary canal of 1,550m were damaged. And in Pisco river the dike in various areas was damaged and the Miraflores road bridge in Humay area was washed away.

In this context, the central government has implemented El Niño phenomenon I and II contingency plans in 1997-1998, throughout the Agriculture and Livestock Ministry (MINAG) in order to rebuild water infrastructures devastated by this phenomenon. Next, the Hydraulic Infrastructure General Direction (DGIH) of the Agriculture Ministry (MINAG) began in 1999 the River Channeling and Collection Structures Protection Program (PERPEC) in order to protect villages, farmlands, agricultural infrastructure, etc located within flood risk areas. The program consisted of financial support for regional government to carry out works of margin protection. In the multiyear PERPEC plan between 2007-2009 it had been intended to execute a total of 206 margin protection works nationwide. These projects were designed to withstand floods with a return period of 50 years, but all the works have been small and punctual, without giving a full and integral solution to control floods. So, every time floods occur in different places, damages are still happening.

MINAG developed a “Valley and Rural Populations Vulnerable to Floods Protection Project” for nine watersheds of the five regions. However, due to the limited availability of experiences, technical and financial resources to implement a pre-investment study for a flood control project of such magnitude, MINAG requested JICA’s help to implementation this study. In response to this request, JICA and MINAG held discussions under the premise of implementing it in the preparatory study scheme to formulate a loan draft from AOD of JICA, about the content and scope of the study, the implementation’s schedule, obligations and commitments of both parties, etc. expressing the



conclusions in the Discussions Minutes (hereinafter “M/D”) that were signed on January 21 and April 16, 2010. This study was implemented on this M/D.

## **(2) Progress of study**

The Profile Study Report for this Project at Program’s level for nine watersheds of five regions has been elaborated by DGIH and sent to the Planning and Investment Office (OPI) on December 23, 2009, and approved on the 30<sup>th</sup> of the same month. Afterwards, DGIH presented the report to the Public Sector Multiannual Programming General Direction (DGPM) (present DGPI) of the Economy and Finance Ministry (MEF) on January 18, 2010. On March 19<sup>th</sup>, DGPM informed DGIH about the results of the review and the correspondent comments.

The JICA Study Team began the study in Peru on September 5<sup>th</sup>, 2010. At the beginning, nine watersheds were going to be included in the study. One, the Ica River was excluded of the Peruvian proposal leaving eight watersheds. The eight watersheds were divided into two groups: Group A with five watersheds and Group B with three watersheds. The study for the first group was assigned to JICA and the second to DGIH. Group A includes Chira, Cañete, Chincha, Pisco and Yauca Rivers’ Watersheds and Group B includes the Cumbaza, Majes and Camana Rivers’ Watersheds.

The JICA Study Team conducted the Profile Study of the five watersheds of Group A, with an accurate pre-feasibility level and handed DGIH the Program Report of group A and the reports of the five watershed projects by late June 2011. Also, the feasibility study has already started, omitting the pre-feasibility study.

For the watersheds of Group B which study corresponded to DGIH, this profile study took place between mid-February and early March 2011 (and not with a pre-feasibility level, as established in the Meetings Minutes), where Cumbaza River Watershed was excluded because it was evident that it would not have an economic effect. The report on the Majes and Camana rivers watersheds were delivered to OPI, and OPI official comments were received through DGIH on April 26<sup>th</sup>, indicating that the performed study for these two watersheds did not meet the accuracy level required and it was necessary to study them again. Also, it was indicated to perform a single study for both rivers because they belong to a single watershed (Majes-Camana).

On the other hand, due to the austerity policy announced on March 31<sup>st</sup>, prior to the new government assumption by new president on July 28<sup>th</sup>, it has been noted that it is extremely difficult to obtain new budget, DGIH has requested JICA on May 6<sup>th</sup> to perform the prefeasibility and feasibility studies of the Majes-Camana Watershed.

JICA accepted this request and decided to perform the mentioned watershed study modifying for the second time the Meeting Minutes (refer to Meetings Minutes Second Amendment about the Initial Report, Lima, July 22<sup>nd</sup>, 2011)

So, the JICA Study Team began in August the prefeasibility study for the watershed above mentioned, which was completed in late November.

Based on the Profile Study with the pre-feasibility level, the four rivers of Cañete, Chincha, Pisco and Majes-Camana excluding Chira and Yauca rivers are selected for the objective rivers for the feasibility study under the restriction of total budget for the Project and viability of social evaluation of each river (refer to Minutes of Meetings on Main Points of Interim Report, Lima , December 5, 2011

DGIH registered 4 rivers to SNIP on July 21, 2011 based on the Profile Study reports (for each basin) except Yauca. Yauca river was not registered due to its low viability of the social evaluation judged by DGIH. And DGIH registered Majes-Camana river to SNIP on January 9, 2012. DGIH submitted the Profile Study reports of 4 rivers (Chira, Cañete, Chincha, Pisco excluding Yauca) with pre-FS level accuracy to OPI, which issued their observations on the reports to DGIH on September 22, 2011.

DGIH revised these profile study report in accordance with the OPI's observation and submitted it to OPI in May 2012 for Pisco river.

OPI examined the revised report transferred it to DGPI, MEF together with their comments in July 2012. DGPI, MEF examined the report and approved the implementation of Feasibility Study with their comments in October 2012

Since the examination process of OPI and DGPI based on SNIP regulation had delayed, JICA executed the feasibility study on the 4 watersheds which were selected based on the Profile Study and submitted the program report of 4 watersheds and the project reports of each watersheds were submitted to DGIH on March 9, 2012 in draft form.

DGIH has been revising the feasibility study report in accordance with the comments of MEF, after completion of revision will obtain the approval on the report from OPI and MEF. The process of the above is as shown in the Table-2.4.1-1.

**Table-2.4.1-1 Process of study and submission of report**

Items	Date	Chira	Ica	Chincha	Pisco	Yauca	Cafete	Majes	Camana	Cumbaza	
Perfil Program		December 30, 2009 : prepared and submitted by DGIH, January 18, 2010 : approved by DGPI									
Start of JICA Study	2010/9/5	A group 5 rivers to be studied by JICA					B group 4 rivers to be studied by DGIH				
Amendment of M/M on ICR (No.1)	2010/11/12	-	excluded by DGIH	-	-	-	transferred to A group	-	-	-	
Responsible Organization	-	JICA	-	JICA			DGIH				
Perfil Program Report	2011/3中旬	-	-	-	-	-	-	Preparation and Submission			
DGIH excluded Cumbaza		-	-	-	-	-	-	-	-	excluded by DGIH	
OPI Observation	2011/4/26	-	-	-	-	-	-	Combination of both rivers and upgrade of study directed by OPI		-	
Amendment of M/M on ICR (No2)	2011/6/22	-	-	-	-	-	-	DGIH requested study of this river to JICA		-	
Pre-F/S Level Study	2011/6/30	Submission to DGIH	-	Submission to DGIH				-	-		
SNIP Registration	2011/7/21	Registration to SNIP	-	Registration to SNIP		No registration to SNIP	Registration to SNIP	-	-		
OPI Observation	2011/9/22	OPI Observation	-	OPI Observation		-	OPI Observation	-	-		
Objectives for F/S Study	2011/12/5	excluded	-	Selected		-	Selected	Selected		-	
Pre-F/S Level Study on Majes-Camana	2011/12/15	-	-	-	-	-	-	Submission to DGIH		-	
Pre F/S Program Report of 6 rivers	2011/12/28	Submission to DGIH	-	Submission to DGIH			Submission to DGIH	Submission to DGIH		-	
FS Draft Report	2012/3/9	-	-	Submission to DGIH		-	Submission to DGIH	Submission to DGIH		-	
DGIH revised report to OPI	-	-	-	2012/5/15	2012/5/14	-	2012/5/21	2012/12/12		-	
OPI report to MEF	-	-	-	2012/7/26		-	2012/7/26	Unknown		-	
MEF approval for FS	-	-	-	2012/10/4	2012/10/16	2012/10/17	-	Unknown		-	
DGIH revision of FS report	-	-	-	Under preparation		-	Under preparation	Unknown		-	
OPI&MEF approval of revised FS report	-	-	-	Unknown	Unknown	-	Unknown	Unknown		-	
Revised Study of Majes-Camana	-	-	-	-	-	-	-	2012/8~2012/11		-	
Expalanation of the above	-	-	-	-	-	-	-	Scheduled in 2013/2/27		-	
Submission of final FS report	-	-	-	scheduled in 2013/3		-	scheduled in 2013/3	scheduled in 2013/3		-	

## 2.4.2 Laws, Regulations, Policies and Guidelines related to the Program

This program has been elaborated following the mentioned laws and regulations, policies and guidelines:

### (1) Water Resources Law N° 29338

#### 1) Article 75 .- Protection of water

The National Authority, in view of the Watershed Council, must ensure for the protection of water, including conservation and protection of their sources, ecosystems and natural assets related to it in the regulation framework and other laws applicable. For this purpose, coordination with relevant government institutions and different users must be done.

The National Authority, throughout the proper Watershed Council, executes supervision and control functions in order to prevent and fight the effects of pollution in the oceans, rivers and lakes. It can also coordinate for that purpose with public administration, regional governments and local governments sectors.

The State recognizes as environmentally vulnerable areas the headwater watersheds where the waters

originate. The National Authority, with the opinion of the Environment Ministry, may declare protected areas the ones not granted by any right of use, disposition or water dumping.

2) Article 119 .- Programs flood control and flood disasters

The National Authority, together with respective Watershed Board, promotes integral programs for flood control, natural or manmade disasters and prevention of flood damages or other water impacts and its related assets. This promotes the coordination of structural, institutional and necessary operational measures.

Within the water planning, the development of infrastructure projects for multi-sectorial advantage is promoted. This is considered as flood control, flood protection and other preventive measures.

**(2) Water Resources Law Regulation N° 29338**

1) Article 118 .- From the maintenance programs of the marginal strip

The Water Administrative Authority, in coordination with the Agriculture Ministry , regional governments, local governments and water user organizations will promote the development of programs and projects of marginal strips forestry protection from water erosive action.

2) Article 259 ° .- Obligation to defend margins

All users have as duty to defend river margins against natural phenomenon effects, throughout all areas that can be influenced by an intake, whether it is located on owned land or third parties' land. For this matter, the correspondent projects will be submitted to be reviewed and approved by the Water National Authority.

**(3) Water Regulation**

Article 49. Preventive measures investments for crop protection are less than the recovery and rehabilitation cost measures. It is important to give higher priority to these protective measures which are more economic and beneficial for the country, and also contribute to public expenses savings.

Article 50. In case the cost of dikes and irrigation channels protection measures is in charge of family production units or it exceeds the payment capacity of users, the Government may pay part of this cost.

**(4) Multi-Annual Sectorial Strategic Plan of the Agriculture Ministry for the period 2007-2011 (RM N° 0821-2008-AG)**

Promotes the construction and repair of irrigation infrastructure works with the premise of having enough water resources and their proper use.

**(5) Organic Law of the Agriculture Ministry, N° 26821**

In Article 3, it is stipulated that the agricultural sector is responsible for executing river works and agricultural water management. This means that river works and water management for agricultural purposes shall be paid by the sector.

**(6) Guidelines for Peruvian Agricultural Policy - 2002, by the Policy Office of MINAG**

**Title 10 - Sectorial Policies**

“Agriculture is a high risk productive activity due to its vulnerability to climate events, which can be anticipated and mitigated... The damage cost to infrastructure, crops and livestock can be an obstacle for the development of agriculture, and as consequence, in the deterioration of local, regional and national levels.”

**(7) River Channeling and Collection Structures Protection Program, PERPEC**

The MINAG’s DGIH started in 1999 the River Channeling and Collection Structures Protection Program (PERPEC) in order to protect communities, agricultural lands and facilities and other elements of the region from floods damages, extending financial support to margin protection works carried out by regional governments.



### 3. IDENTIFICATION

#### 3.1 Diagnosis of the Current Situation

##### 3.1.1 Nature

##### (1) Location

Figure 3.1.1-1 shows the location map of the Pisco River.



Figure 3.1.1-1 Objective river for the study

## (2) Watershed overall description

Pisco River runs approximately 200 km from the capital Lima, and borders the Chincha River watershed to the north. The surface of the watershed is about 4,300 km<sup>2</sup> which is average among the five selected watersheds in this study. It is an elongated watershed, and altitudes over 4,000 m occupy 20% of the total. The river flows in the lower watershed with an average gradient of 1/90 and its width varies between 200 and 600 meters.

The annual rainfall around 500 mm at altitudes greater than 4,000 m and 10 mm at altitudes less than 1,000 meters. Thus, the average flow rate is reduced.

Regarding the vegetation, the upper watershed is occupied in large part by grassland, and the lower and middle watersheds of deserts. In the lower watershed, also have farmlands on both river banks.

### 3.1.2 Socio-Economic Conditions of the Study Area

#### (1) Administrative division and surface

The Pisco River is located in the Pisco province, Ica Region. Table 3.1.2-1 shows the main districts surrounding this river, with their corresponding surface.

**Table 3.1.2-1 Districts surrounding Pisco river with areas**

Region	Province	District	Area (km <sup>2</sup> )
Ica	Pisco	Pisco	24.92
		San Clemente	127.22
		Tupac Amaru	55.48
		San Andres	39.45
		Humay	1,112.96
		Independencia	273.34

#### (2) Population and number of households

The following Table 3.1.2-2 shows how population varied within the period 1993-2007. In 2007, from 119,975 inhabitants, 89% (106,394 inhabitants) lived in urban areas while 11% (13,581 inhabitants) lived in rural areas.

Population is increasing in all districts. However, the population tends to decrease, except in Humay and Independencia.

**Table 3.1.2-2 Variation of the urban and rural population**

District	Total Population 2007				Total Population 1993				Variation (%)			
	Urban	%	Rural	%	Urban	%	Rural	%	Urban	%	Rural	%
Pisco	54.677	99 %	320	1 %	54.997	51.639	99 %	380	1 %	52.019	0,4 %	-1,2 %
San Clemente	18.849	98 %	475	2 %	19.324	13.200	93 %	1.002	7 %	14.202	2,6 %	-5,2 %
Túpac Amaru Inca	14.529	99 %	147	1 %	14.676	9.314	98 %	228	2 %	9.542	3,2 %	-3,1 %
San Andrés	11.495	87 %	1.656	13 %	13.151	10.742	86 %	1.789	14 %	12.531	0,5 %	-0,6 %
Humay	3.099	57 %	2.338	43 %	5.437	2.016	46 %	2.331	54 %	4.347	3,1 %	0,0 %
Independencia	3.745	30 %	8.645	70 %	12.390	1.630	19 %	7.004	81 %	8.634	6,1 %	1,5 %
<b>Total</b>	<b>106.394</b>	<b>89 %</b>	<b>13.581</b>	<b>11 %</b>	<b>119.975</b>	<b>88.541</b>	<b>87 %</b>	<b>12.734</b>	<b>13 %</b>	<b>101.275</b>	<b>1,3 %</b>	<b>0,5 %</b>

Source: Prepared by JICA Study Team, Statistics National Institute- INEI, 2007 and 1993 Population and Housing Census.

Table 3.1.2-3 shows the number of households and members per home in 2007. Each house has between 3.8 and 4.4 people, according to the district. Each family has an average between 3,7 and 4,1 people.



**Table 3.1.2-3 Number of households and families**

Variables	District					
	Pisco	San Clemente	Túpac Amaru Inca	San Andrés	Humay	Independencia
Population (inhabitants)	54,997	19,324	14,676	13,151	5,437	12,390
Number of households	12,483	4,837	3,609	3,087	1,409	3,062
Number of families	13,356	5,163	3,828	3,206	1,455	3,204
Members per household (person/home)	4.41	4.00	4.07	4.26	3.86	4.05
Members per family (person/family)	4.12	3.74	3.83	4.10	3.74	3.87

**Table 3.1.2-4 Number of households and families**

Variables	District					
	Pisco	San Clemente	Túpac Amaru Inca	San Andrés	Humay	Independencia
Population (inhabitants)	54,997	19,324	14,676	13,151	5,437	12,390
Number of households	12,483	4,837	3,609	3,087	1,409	3,062
Number of families	13,356	5,163	3,828	3,206	1,455	3,204
Members per household (person/home)	4.41	4.00	4.07	4.26	3.86	4.05
Members per family (person/family)	4.12	3.74	3.83	4.10	3.74	3.87

### (3) Occupation

Table 3.1.2-4, shows occupation lists of local inhabitants itemized by sector. In Humay and Independencia, there is a predominance of primary sector accounts for more than 70% of the occupation. In the remaining districts, the largest percentage is concentrated in the tertiary sector.

**Table 3.1.2-4 Occupation**

	District											
	Pisco		San Clemente		Túpac Amaru Inca		San Andrés		Humay		Independencia	
	People	%	People	%	People	%	People	%	People	%	People	%
EAP	19,837	100	7,027	100	5,057	100	4,406	100	2,011	100	4,451	100
Primary Sector	1,657	8.4	2,381	33.9	1,065	21.1	1,429	32.4	1,512	75.2	3,234	72.7
Secondary Sector	4,866	24.5	1,328	18.9	1,366	27.0	767	17.4	93	4.6	259	5.8
Tertiary Sector	13,313	67.1	3,318	47.2	2,626	51.9	2,207	50.1	406	20.2	958	21.5

\* Primary Sector: agriculture, livestock, forestry and fishing; secondary: mining, construction, manufacture; tertiary: services and others

### (4) Poverty index

Table 3.1.2-5 shows poverty rate. 18.7% of the population (22,406 inhabitants) belongs to the poor segment, and 0.4% (493 people) to the extreme poverty segment. Pisco is noted for its low poverty rate and extreme poverty from 15.8% and 0.3% respectively, compared to other districts.

**Table 3.1.2-5 Poverty index**

	District													
	Pisco		San Clemente		Túpac Amaru Inca		San Andrés		Humay		Independencia			
	People	%	People	%	People	%	People	%	People	%	People	%	Total	%
Regional Population	54,997	100	19,324	100	14,676	100	13,151	100	5,437	100	12,390	100	119,975	100
In poverty	8,716	15.8	4,455	23.1	3,042	20.7	2,613	19.9	1,024	18.8	2,556	20.6	22,406	18.7
In extreme poverty	172	0.3	126	0.7	69	0.5	39	0.3	22	0.4	65	0.5	493	0.4

### (5) Type of housing

The walls of the houses are built 45% of bricks or cement, and 19% of adobe and mud. The floor is made 87% of earth or cement.

The public drinking water service in Humay and Independencia is low, with 25%. Except these two districts, the coverage of this service is 45% on average. Meanwhile, sewage service is 48% on average, but again and Independencia Humay shows a low coverage of 11% and 13% respectively.

The electrification reaches 65% on average.

**Table 3.1.2-6 Type of housing**

Variable/Indicator	Districts											
	Pisco		San Clemente		Túpac Amaru Inca		San Andrés		Humay		Independencia	
	Hogares	%	Hogares	%	Hogares	%	Hogares	%	Hogares	%	Hogares	%
<b>Name of housings</b>												
Common residents housing	12.483	83,7	4.837	84,1	3.609	90	3.087	88,2	1.409	79,9	3.062	87,8
<b>Walls materials</b>												
Bricks or cement	7.600	60,9	1.339	27,7	1.198	33,2	2.088	67,6	65	4,6	401	13,1
Adobe and mud	1.008	8,1	1.780	36,8	284	7,9	159	5,2	644	45,7	1.621	52,9
Bamboo + mud or wood	623	5,0	80	1,7	99	2,7	113	3,7	76	5,4	298	9,7
Others	3.252	26,1	1.638	33,9	2.028	56,2	727	23,6	624	44,3	742	24,2
<b>Floor Materials</b>												
Soil	4.199	33,6	2.552	52,8	2.244	62,2	894	29	899	63,8	1.896	61,9
Cement	5.752	46,1	2.109	43,6	1.179	32,7	1.749	56,7	438	31,1	997	32,6
Ceramics, parquet, quality wood	2.320	18,6	136	2,8	131	3,6	361	11,7	40	2,8	147	4,8
Others	212	1,7	40	0,8	55	1,5	83	2,7	32	2,3	22	0,7
<b>Running water system</b>												
Public network within household	8.351	66,9	2.359	48,8	2.226	61,7	1.928	62,5	266	18,9	706	23,1
Public network within building	726	5,8	302	6,2	255	7,1	352	11,4	355	25,2	67	2,2
public use	645	5,2	109	2,3	163	4,5	30	1	3	0,2	139	4,5
<b>Sewage</b>												
Public sewage within household	7.771	62,3	1.729	35,7	1.712	47,4	1.941	62,9	157	11,1	410	13,4
Public sewage within building	526	4,2	113	2,3	79	2,2	201	6,5	178	12,6	26	0,8
Septic Tank	977	7,8	1.532	31,7	587	16,3	302	9,8	250	17,7	1.623	53
<b>Electricity</b>												
Public electric service	8.933	71,6	2.975	61,5	2.043	56,6	2.342	75,9	949	67,4	1.283	41,9
<b>Member quantity</b>												
<b>Common residents housing</b>	<b>13.356</b>	<b>100</b>	<b>5.163</b>	<b>100</b>	<b>3.828</b>	<b>100</b>	<b>3.206</b>	<b>100</b>	<b>1.455</b>	<b>100</b>	<b>3.204</b>	<b>100</b>
<b>Appliances</b>												
More than three	5.976	44,7	1.426	27,6	1.086	28,4	1.417	44,2	402	27,6	553	17,3
<b>Communication Services</b>												
Phones and mobiles	11.385	85,2	3.401	65,9	2.795	73,0	2.579	80,4	630	43,3	1.719	53,7

Source: Prepared by JICA Study Team, Statistics National Institute- INEI, 2007 Population and Housing Census.

## (6) GDP

Peru's GDP in 2010 was US\$ 153.919.000.000. The growth rate in the same year was of + 8.8 % compared with the previous year.

Itemized by regions, Ica registered a growth of 8.1 %, Piura 5.4 %, Lima 10.0 % and Arequipa 8.5 %. Particularly Lima regions registered Figures that were beyond the national average.

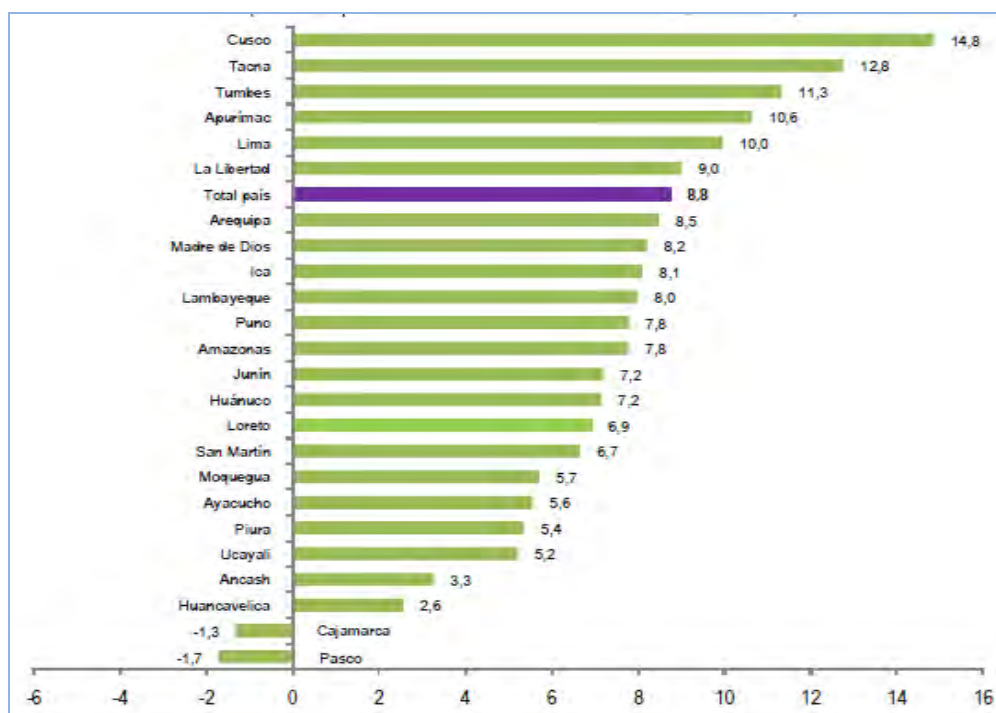

Fuente INEI – Dirección Nacional de Cuentas Nacionales-2010、国立統計局 – INEIと中央準備銀行 – BCR

**Figure 3.1.2-1 Growth rate of GDP per region (2010/2009)**

The table below shows the contribution of each region to the GDP. Lima Region represents almost half of the total, that is to say 45.0%. Arequipa contributed with 5.5 %, Piura 4.3 % and Ica 3.0 %. Taxes and duties contributed with 6.5 % and 0.3 %, respectively.

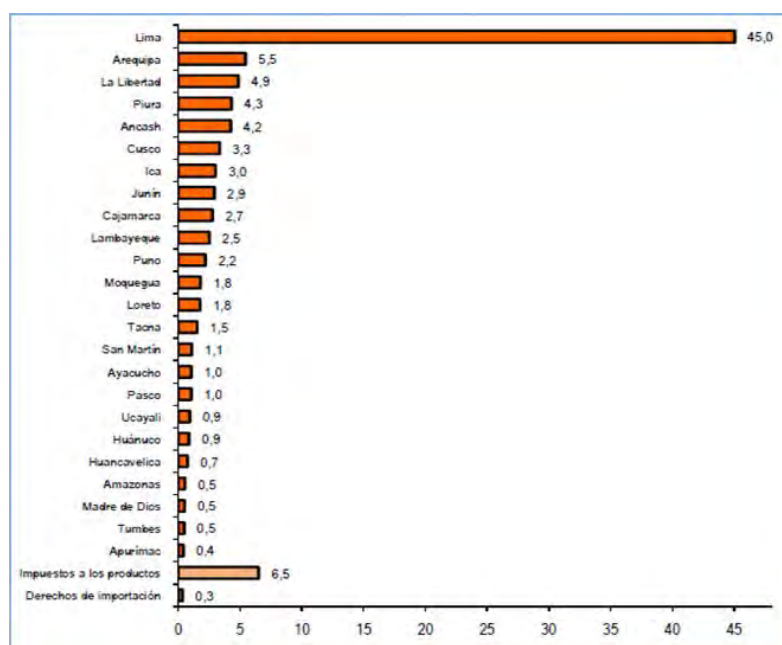

Fuente INEI – Dirección Nacional de Cuentas Nacionales-2010、国立統計局 – INEIと中央準備銀行 – BCR

**Figure 3.1.2-2 Region contribution to GDP**

The GDP per capita in 2010 was of S/.14,832 (5,727 US\$). The Table below shows data per region: Lima S/.19,573(7,557 US\$), Arequipa S/.19,575( 7,558US\$), Ica S/.17,500( 6,757US\$) show the higher value than national average, but Piura S/.10,585(4,087 US\$) is lower than the national average.

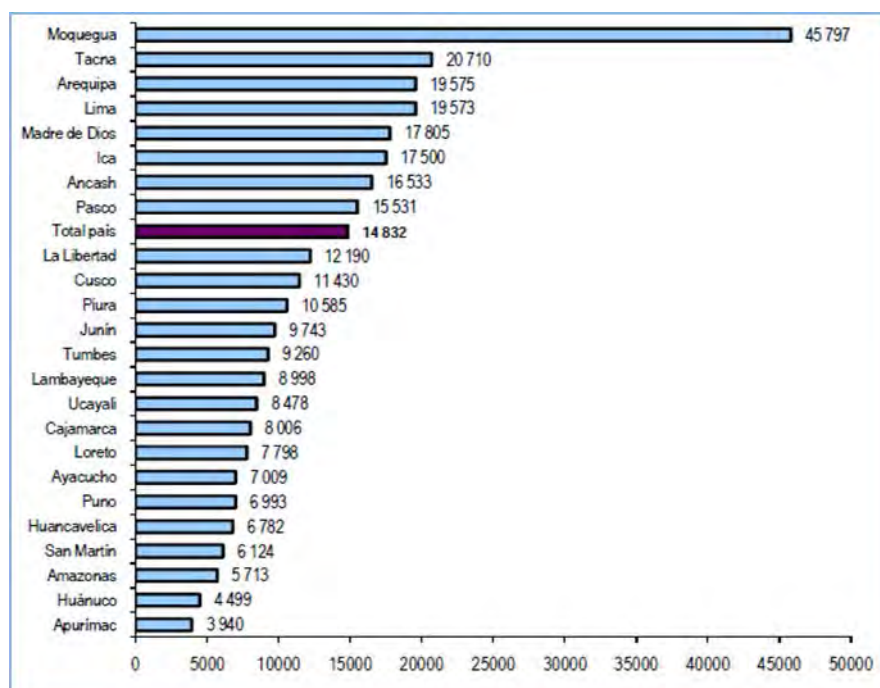

Fuente INEI – Dirección Nacional de Cuentas Nacionales-2010、国立統計局 – INEIと中央準備銀行 – BCR

**Figure 3.1.2-3 GDP per capita (2010)**

Table 3.1.2-7 shows the variation along the years of the GDP per capita per region, during the last 10 years (2001-2010).

The GDP national average increased in 54.8% within 10 years from 2001 until 2010. The Figures per region are: +96.6 % for Ica, +65.5 % for Arequipa, +55.2 % for Piura y +54.8 % for Lima.

Figures in Table 3.1.2-7 were established taking 1994 as base year.

**Table 3.1.2-7 Variation of the GDP per capita (2001-2009)**

(1994 Base year, S/.)

Departamento	2001	2002	2003	2004	2005	2006	2007P/	2008P/	2009P/	2010E/	Variación acumulada 2001-2010 (%)
Total país	4 601	4 765	4 890	5 067	5 345	5 689	6 121	6 643	6 625	7 124	54,8
Amazonas	1 835	1 910	1 996	2 081	2 212	2 349	2 510	2 684	2 761	2 959	61,3
Ancash	4 037	4 703	4 772	4 876	4 999	5 089	5 408	5 852	5 824	5 979	48,1
Apurímac	1 216	1 278	1 334	1 400	1 494	1 619	1 653	1 691	1 770	1 946	60,0
Arequipa	5 387	5 766	5 895	6 143	6 488	6 807	7 786	8 379	8 307	8 917	65,5
Ayacucho	1 788	1 870	1 942	1 900	2 045	2 207	2 448	2 640	2 896	3 020	68,9
Cajamarca	2 493	2 731	2 947	2 968	3 165	3 113	2 864	3 094	3 295	3 235	29,8
Cusco	2 194	2 086	2 195	2 565	2 768	3 071	3 340	3 554	3 685	4 202	91,5
Huancavelica	2 700	2 632	2 683	2 697	2 864	3 014	2 903	2 959	3 039	3 090	14,4
Huánuco	1 678	1 694	1 833	1 866	1 890	1 915	1 942	2 050	2 044	2 170	29,4
Ica	4 055	4 259	4 343	4 663	5 214	5 582	6 025	7 265	7 457	7 973	96,6
Junín	3 245	3 311	3 350	3 527	3 505	3 856	4 072	4 379	4 248	4 520	39,3
La Libertad	3 162	3 316	3 483	3 410	3 697	4 216	4 586	4 874	4 895	5 269	66,6
Lambayeque	2 941	3 046	3 132	2 959	3 164	3 300	3 615	3 882	3 963	4 240	44,2
Lima	6 451	6 579	6 700	6 925	7 284	7 817	8 520	9 314	9 219	9 990	54,8
Loreto	2 827	2 917	2 936	2 995	3 079	3 192	3 287	3 402	3 430	3 621	28,1
Madre de Dios	4 441	4 708	4 550	4 846	5 171	5 215	5 617	5 878	5 564	5 862	32,0
Moquegua	10 405	11 967	12 670	13 455	13 882	13 794	13 606	14 201	13 863	14 503	39,4
Pasco	5 137	5 552	5 481	5 634	5 644	6 062	6 711	6 729	6 349	6 187	20,4
Piura	2 733	2 780	2 847	3 049	3 192	3 472	3 780	4 007	4 059	4 241	55,2
Puno	2 105	2 236	2 234	2 270	2 365	2 460	2 617	2 731	2 800	2 992	42,1
San Martín	2 026	2 059	2 094	2 232	2 393	2 476	2 655	2 870	2 928	3 075	51,8
Tacna	6 004	6 124	6 382	6 643	6 782	6 941	7 256	7 458	7 256	8 067	34,4
Tumbes	2 744	2 802	2 873	3 018	3 385	3 212	3 427	3 594	3 611	3 957	44,2
Ucayali	3 063	3 149	3 203	3 411	3 584	3 754	3 846	4 007	4 040	4 190	36,8

Fuente INEI – Dirección Nacional de Cuentas Nacionales-2010, 国立統計局 – INEIと中央準備銀行 – BCR

### 3.1.3 Agriculture

Next is a summarized report on the current situation of agriculture in the Watershed of the Majes – Camana River, including irrigation commissions, crops, planted area, performance, sales, etc

#### (1) Irrigation sectors

Table 3.1.3-1 and 3.1.3-2 shows basic data on the irrigation commissions of the Pisco River. In the watershed of the Pisco River there are 19 irrigation sectors, 6 irrigation commissions with 3,774 beneficiaries. The surface managed by these sectors amounts 22,468 hectares.

**Table 3.1.3-1 Basic data of the irrigation commissions**

Irrigation Sectors	Irrigation Commissions	Areas under irrigation		N° of Beneficiaries (People)	River
		ha	%		
Pisco	Casalla	2.276	10	513	Pisco
	El Pueblo Figueroa	756	3	138	
	Caucato	1.612	7	325	
	Chongos	453	2	74	
Independencia	Agua Santa - El Porvenir	469	2	63	
	Francia	931	4	126	
	Montalván	1.596	7	275	
	Manrique	1.555	7	288	
Chacarilla	Condor	1.970	9	315	
Dadelso					
Jose Olaya					
Mencia					
San Jacinto					
Urrutia					
Cabeza de Toro	Cabeza de Toro	6.123	27	633	
Murga	Murga - Casaconcha	1.383	6	273	
	La Floresta	303	1	51	
	Bernales	1.286	6	294	
	Miraflores	129	1	35	
	Chunchanga	460	2	75	
Humay	San Ignacio	333	1	56	
	Montesierpe	449	2	118	
	Pallasca Tambo Colorado	145	1	65	
	Huaya Letrayoc	238	1	57	
<b>Total</b>		<b>22.468</b>	<b>100</b>	<b>3.774</b>	

Source: Prepared by JICA Study Team, Users Board of Pisco, October 2011

## (2) Main crops

Table 3.1.3-2 shows the variation between 2004 and 2009 of the planted surface and the performance of main crops. In the Pisco River Watershed the planted area tends to be maintained or reduced due to crop surface reduction because of cotton. Instead of this, the area of alfalfa and corn (yellow) is increasing. The revenue was S/.132,512,157 in 2008-2009, which is the lousiest level reached in the last five years. This reduction is due mostly for the reduction of cotton crop and the low transaction price. The main crops in this watershed are cotton, alfalfa and corn (yellow).

**Table 3.1.3-2 Sowing and sales of main crops**

	Variables	2004-2005	2005-2006	2006-2007	2007-2008	2008-2009
Cotton	Planted Area (ha)	16,598	15,586	13,300	13,536	7,771
	Unit performance (kg/Ha)	2,123	1,923	2,104	2,209	2,166
	Harvest (Kg)	35,237,554	29,971,878	27,983,200	29,901,024	16,831,986
	Unit price (S/./kg)	2.13	2.18	2.81	2.76	1.95
	Sales (S/.)	75,055,990	65,338,694	78,632,792	82,526,826	32,822,373
Alfalfa	Planted Area (ha)	2,817	2,941	2,966	3,739	4,133
	Unit performance (kg/Ha)	31,965	29,626	30,485	24,078	25,770
	Harvest (Kg)	90,045,405	87,130,066	90,418,510	90,027,642	106,507,410
	Unit price (S/./kg)	0.10	0.10	0.10	0.10	0.10
	Sales (S/.)	9,004,541	8,713,007	9,041,851	9,002,764	10,650,741
Corn (yellow)	Planted Area (ha)	1,065	1,410	2,377	2,447	4,167
	Unit performance (kg/Ha)	7,289	6,960	8,197	8,665	8,262
	Harvest (Kg)	7,762,785	9,813,600	19,484,269	21,203,255	34,427,754
	Unit price (S/./kg)	0.60	0.63	0.77	0.85	0.73
	Sales (S/.)	4,657,671	6,182,568	15,002,887	18,022,767	25,132,260
Corn	Planted Area (ha)	813	2,188	1,272	1,605	2,088
	Unit performance (kg/Ha)	13,279	10,511	11,579	11,672	9,672
	Harvest (Kg)	10,795,827	22,998,068	14,728,488	18,733,560	20,195,136
	Unit price (S/./kg)	0.63	0.46	0.79	0.73	0.80
	Sales (S/.)	6,801,371	10,579,111	11,635,506	13,675,499	16,156,109
Asparagus	Planted Area (ha)	648	663	720	1,028	980
	Unit performance (kg/Ha)	6,654	7,231	6,491	4,375	4,788
	Harvest (Kg)	4,311,792	4,794,153	4,673,520	4,497,500	4,692,240
	Unit price (S/./kg)	3.13	3.02	3.65	2.65	2.79
	Sales (S/.)	13,495,909	14,478,342	17,058,348	11,918,375	13,091,350
Tangelo	Planted Area (ha)	311	331	367	367	367
	Unit performance (kg/Ha)	26,463	24,033	26,432	27,109	26,608
	Harvest (Kg)	8,229,993	7,954,923	9,700,544	9,949,003	9,765,136
	Unit price (S/./kg)	0.52	0.56	0.59	0.55	0.51
	Sales (S/.)	4,279,596	4,454,757	5,723,321	5,471,952	4,980,219
Paprika	Planted Area (ha)	223	354	461	310	209
	Unit performance (kg/Ha)	5,058	5,068	5,490	5,864	5,849
	Harvest (Kg)	1,127,934	1,794,072	2,530,890	1,817,840	1,222,441
	Unit price (S/./kg)	4.64	3.45	5.67	5.33	4.02
	Sales (S/.)	5,233,614	6,189,548	14,350,146	9,689,087	4,914,213
Tomatoe	Planted Area (ha)	306	349	307	258	293
	Unit performance (kg/Ha)	71,395	54,399	57,824	65,525	60,604
	Harvest (Kg)	21,846,870	18,985,251	17,751,968	16,905,450	17,756,972
	Unit price (S/./kg)	0.97	0.83	0.76	1.08	0.86
	Sales (S/.)	21,191,464	15,757,758	13,491,496	18,257,886	15,270,996
Grapes	Planted Area (ha)	136	174	192	218	230
	Unit performance (kg/Ha)	8,640	11,429	10,332	17,345	19,504
	Harvest (Kg)	1,175,040	1,988,646	1,983,744	3,781,210	4,485,920
	Unit price (S/./kg)	1.66	1.88	2.21	1.95	2.00
	Sales (S/.)	1,950,566	3,738,654	4,384,074	7,373,360	8,971,840
Lima beans	Planted Area (ha)	103	253	136	97	163
	Unit performance (kg/Ha)	1,055	1,062	1,230	1,212	1,020
	Harvest (Kg)	108,665	268,686	167,280	117,564	166,260
	Unit price (S/./kg)	3.34	2.80	2.95	3.65	3.14
	Sales (S/.)	362,941	752,321	493,476	429,109	522,056
Others	Planted Area (ha)	615	907	989	518	1,644
Total	Planted Area (ha)	23,635	25,156	23,087	24,123	22,045
	Harvest (Kg)	180,641,865	185,699,343	189,422,413	196,934,048	216,051,255
	Sales (S/.)	142,033,663	136,184,761	169,813,897	176,367,624	132,512,157

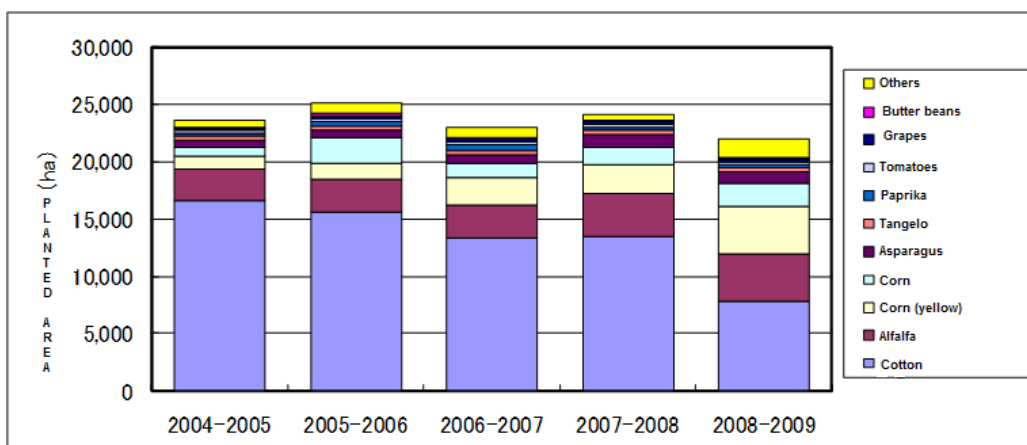

Figure 3.1.3-1 Planted surface

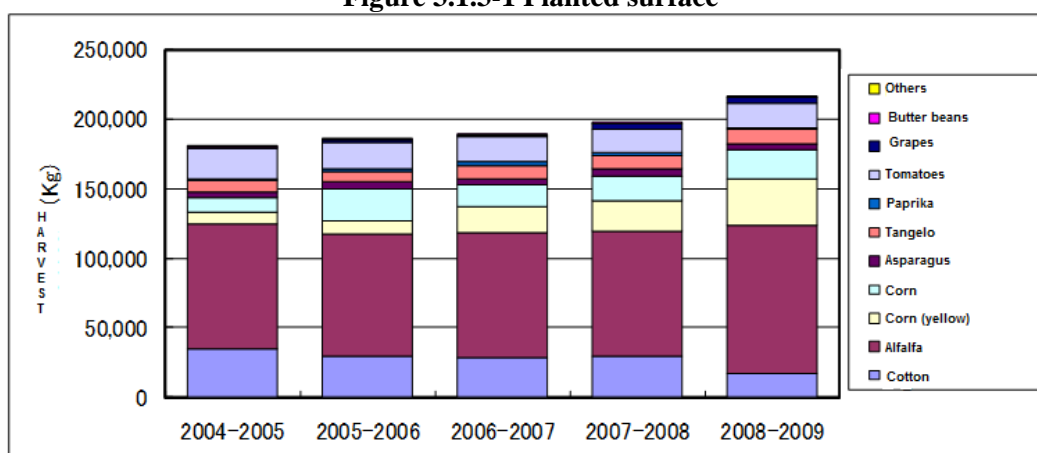

Figure 3.1.3-2 Harvest

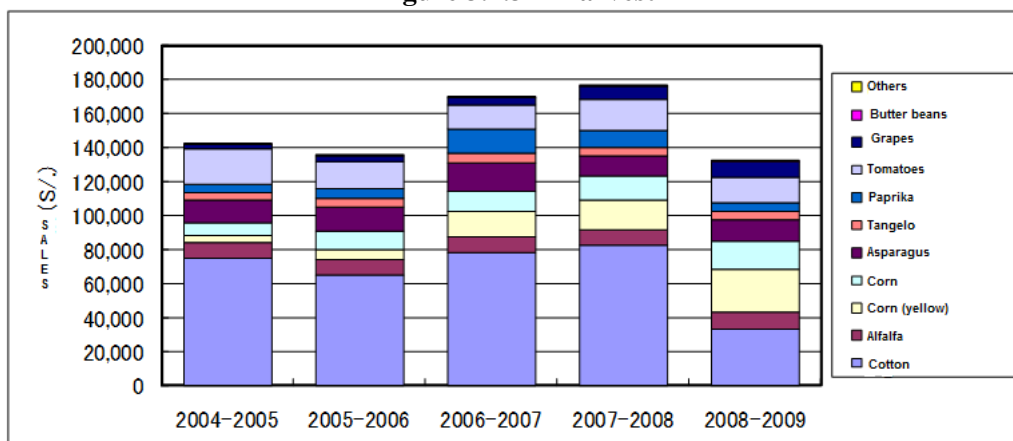

Figure 3.1.3-3 Sales

### 3.1.4 Infrastructure

#### (1) Road infrastructures

Table 3.1.4-1 shows irrigation infrastructures of Pisco River. There are 41 intakes, 41 main channels and 167 secondary channels.



**Table 3.1.4-1 Irrigation infrastructure**

Nº	STRUCTURE	QUANTITY
1	INTAKE	41
2	CHANNEL	41
	MAIN	41
	SECONDARY	167
3	WATERWORKS	11
4	SEWERS	73
5	SPILLWAY	6
6	DUMP	105
7	FALLS	163
8	CANOES	85
9	COVERED CONDUCT	2
10	BRIDGES	36
	PEDESTRIAN	36
	VEHICLE	381
11	QUICK	10
12	TRAP	3
13	METER	39
14	TUNNELS	32

Source: Jica Study Team

### 3) PERPEC

Table 3.1.4-4 shows implemented projects by PERPEC between 2006 and 2009.

**Table 3.1.4-2 Projects implemented by PERPEC**

N°	Year	Work name	Location				Description	Total cost (S/.)		
			Departament	Province	District	Town				
1	2006	Pisco River coastal defense - Condor area	Ica	Pisco	Independencia	Cóndor	Channel conformation	0.5	Km.	186,723.00
2	2007	Hydraulic infrastructure protection with coastal defense on right bank of Pisco River, Manrique area, Independencia District, Pisco Province - Ica Region	Ica	Pisco	Independencia	Manrique	Dike with gavions and /or cushion	0.84	Km	501,939.72
3	2007	Channel and drains conduction capability restitution on right bank of Pisco River	Ica	Pisco	Independencia	Several	Channel box replacement	17.03	Km	145,810.00
4	2007	Main channel cleanliness Chunchanga- Murga-Pisco Area	Ica	Pisco	Humay	Chunchanga	Channel box replacement	2.824	Km	42,700.00
5	2007	Channel and drains conduction capability restitution on left bank of Pisco River	Ica	Pisco	Independencia	Varias	Channel box replacement	10.909	Km	92,504.00
							Drains Rehabilitation	6.307	Km	
6	2007	Slide rehabilitation of Huaya, Tambo colorado and Miraflores derivation channels - Pisco	Ica	Pisco	Humay	Varias	Intake rockfilling	0.051	Km	52,003.00
7	2007	Main and secondary channels rehabilitation in the Huancano-Pampano High area of Pisco River	Ica	Pisco	Huancano	Varias	Channel sheathing	0.5435	Km	71,219.00
8	2007	Rehabilitation in Cabeza de Toro and Storage pools fixing for agricultural supply purposes in Cabeza de Toro - Pisco River	Ica	Pisco	Independencia	Cabeza de Toro	Replacement and fixing of pools	55	und.	106,819.00
9	2008	Coastal defense with short breakwaters with tumbling rocks right bank (several areas) Pisco river (Contingency)	Ica	Pisco	Independencia	Several Areas	Building of 23 breakwaters of 40 mts.	23	Unid	107,735.00
							Dike conformation	1	Km	
10	2008	Derivation channel protection in Chunchanga (Contingency)	Ica	Pisco	Pisco	Chunchanga	Desilting	400	ml	279,240.00
							Dike with rockfilling	200	ml	
11	2008	Coastal defense with aims of San Ignacio intakes protection on the right bank and Bernales on the left bank of Pisco River, Bernales area, Humay district, Pisco province (Prevention)	Ica	Pisco	Humay	Bernales	Rockfilling dike	260	ml	435,781
							Rock breakwaters	19	und	
							Dike conformation	520	ml	

### 3.1.5 Real Flood Damages

#### (1) Damages on a nationwide scale

Table 3.1.5-1 shows the present situation of flood damages during the last five years (2003-2007) in the whole country. As observed, there are annually dozens to hundreds of thousands of flood affected inhabitants.

**Table 3.1.5-1 Situation of flood damages**

		Total	2003	2004	2005	2006	2007
Disasters	Cases	1,458	470	234	134	348	272
Victims	persons	373,459	118,433	53,370	21,473	115,648	64,535
Housing loss victims	persons	50,767	29,433	8,041	2,448	6,328	4,517
Decesased individuals	persons	46	24	7	2	9	4
Partially destroyed houses	Houses	50,156	17,928	8,847	2,572	12,501	8,308
Totally destroyed	Houses	7,951	3,757	1,560	471	1,315	848

Source : SINADECI Statistical Compendium

Peru has been hit by big torrential rain disasters caused by the El Niño Phenomenon. Table 3.1.5-2 shows damages suffered during the years 1982-1983 and 1997-1998 with extremely serious effects. Victims were approximately 6,000,000 inhabitants with an economic loss of about US\$ 1,000,000,000 in 1982-1983. Likewise, victims number in 1997-1998 reached approximately 502.461 inhabitants with economic loss of US\$ 1,800,000,000. Damages in 1982-1983 were so serious that they caused a decrease of 12 % of the Gross National Product.

**Table 3.1.5-2 Damages**

Damages	1982-1983	1997-1998
Persons who lost their homes	1.267.720	—
Victims	6.000.000	502.461
Injured	—	1.040
Deceased	512	366
Missing persons	—	163
Partially destroyed houses	—	93.691
Totally destroyed houses	209.000	47.409
Partially destroyed schools	—	740
Totally destroyed schools	—	216
Hospitals and health centers partially destroyed	—	511
Hospitals and health centers totally destroyed	—	69
Damaged arable lands (ha)	635.448	131.000
Head of cattle loss	2.600.000	10.540
Bridges	—	344
Roads (km)	—	944
Economic loss (\$)	1.000.000.000	1.800.000.000

“—”: No data

#### (2) Disasters in the watersheds object of this study

Table 3.1.5-3 summarizes damages occurred in the Ica region.

**Table 3.1.5-3 Disasters in the Ica Region**

Years	1995	1996	1997	1998	1999	2000	2001	2002	2003	2004	2005	2006	2007	2008	2009	2010	Total	Media
LANDSLIP																	0	
FLOOD																	0	
COLLAPSE											2						2	
LANDSLIDE									2	1				1			4	
AVALANCHE	2		2		5	2				2	1	1	3	1		1	20	
TOTAL DESASTRES DE SEDIMENTOS	2	0	2	0	5	2	0	0	2	3	3	1	3	2	0	1	26	2
TOTAL FLOODING	4	4	0	13	14	1	2	0	0	1	1	0	4	6	1	0	51	3

### 3.1.6 Results on the Visits to Study Sites

JICA Study Team made some technical visits to the selected watersheds and identified some challenges on flood control through visits and interviews to regional government authorities and irrigation associations on damages suffered in the past and the problems each watershed is currently facing.

#### (1) Interviews

(On critical points)

- The 1<sup>st</sup> critical point is 1.5 km downstream the bridge (km7). Flooded water floods the left bank's community. There is no dike under this point (1,5km from the bridge)
- The 2<sup>nd</sup> critical point is 11.5km away, where flood to the left bank is produced
- There is an intake on km 14.5. The work itself is not destroyed, but what is destroyed is the protection constructed on the right bank. There is a water channel connected to the urban area and an irrigation channel that covers all the left bank
- There are cement blocks criss-crossed on the left bank (km 12.5 and 13.5)
- The bed has elevated 3 meters approximately in the last 40 years (between 1970 and 2010)
- 40 years ago the dike existed so that there is no inundation, however due to the insufficient maintenance the dike seems to be washed away by floods so that the inundation frequently occurs nowadays.
- There is purify plant and an intake on km 28
- The 3<sup>rd</sup> critical point is on km 20.5. Conduction tubes were dragged when the flood occurred on this area
- There are 5 reservoirs upstream, with a total capacity of 54 x 106m<sup>3</sup>.
- When El Niño occurred in Quitasol, 50km upstream, always produces floods

(Others: visited sites by the Study Team)

○ Intake, km 27,5

- Currently 7m<sup>3</sup>/s of water are taken (to supply 620 ha of agricultural lands)
- A bank against overflowing was built on the right bank
- Flood season: December through March

○ Flood point, km 5,5

- Bank protection works were executed using track type tractors, hydraulic shovels and trailers. The stones were brought from upstream the intake
- With this section 500m<sup>3</sup>/s of water will flow (during El Niño a 700m<sup>3</sup>/s flow was reduced and we adopted the minimum value of such event)
- The left bank's area is private property, but it was decided to adopt this width considering that is not necessary to buy the land
- There are cement blocks criss-crossed up to the bed's height + 2meters
- There is no other disaster prevention plan in this area
- We are planning to build a new bridge 100meters downstream the existing bridge in km7 (Panamericana Highway)
- The project's building cost of the dike + cement blocks installation (L=800mts on both banks) is estimated in S/. 960.000 (equivalent to 30 million Japanese yens)

○ Km 13,5 (Floodable area)

- A new dike on the exterior of the former dike is being built on the left bank. However, the work was stopped without being finished. The soil of the area was originally crop soil and then

- passed to be State land, 2 years was this area abandoned
- The construction cost of the dike of 600 meters is \$850.000
- Casaya Intake
  - The intake was not destroyed by floods, but the right bank protection did
- Murga Bridge
  - Left bank protection was not destroyed during 1998 floods, but was destroyed during the February 1999 event. The penetration depth was approx 1meter
- Montalbán Intake
  - The intake was destroyed due to 1998 floods. Previously, the upstream bed was elevated and the high waters entered into the right bank (where the intake is) destroying the floodgate
  - Water level reaches chest height
  - Right bank's channel was buried
  - The river's width at the intakes area is 90m approx, which is narrower than the upstream and downstream sections. The land of the left bank is private property
  - The value of agricultural lands is approx %5,000 per hectare (10.000 m<sup>2</sup>).
- Francia Intake (between km 19,5 and km 20)
  - Because this area is not protected, both banks flooded
  - The bed has risen in the last years
  - Limit demarking of private properties has been investigated by MINAG in 1998. Originally, this work was done by INRENA and then passed to MINAG. It is probable that there is similar information in another watershed

## **(2) Description of the visit to the study sites**

Figure 3.1.6-1 shows pictures of main sites visited.

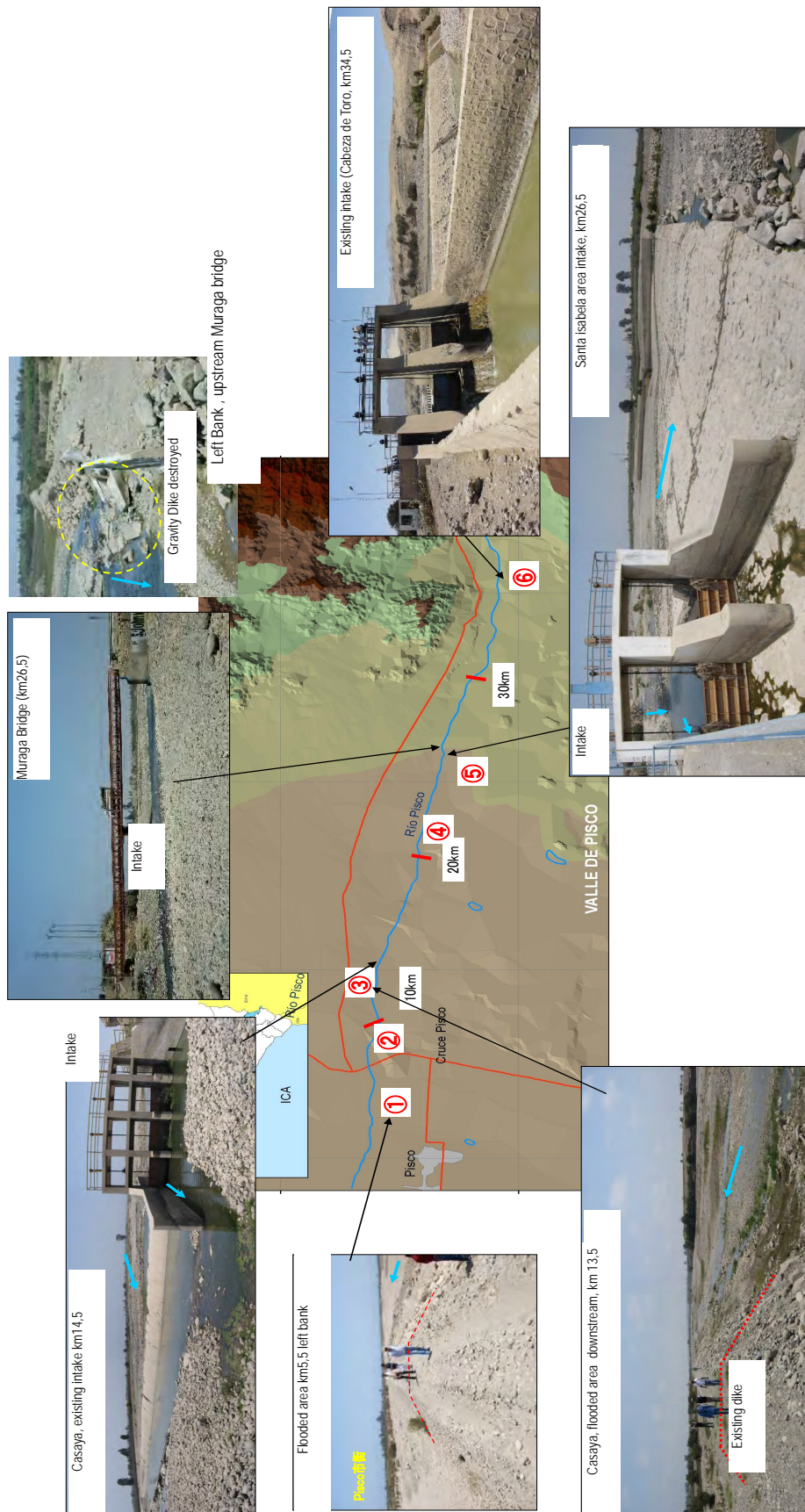

Figure 3.1.6-1 Visit to the study site (Pisco River)

### (3) Challenges and measures

The following table shows challenges and possible solution measures for flood control considered at this moment, based on the results of technical visits.

#### 1) Challenge 1: Flood area (km 5.5)

Current situation and challenges	<ul style="list-style-type: none"> <li>• A flood of 700 m<sup>3</sup>/s was registered during El Niño</li> <li>• Pisco Municipality was flooded by the overflow of the left bank in km 5.5</li> <li>• The bed has been rising up approx 3 meters in the past 40 years</li> <li>• The dike needs to be extended to the lower region, but there is no actual concrete plan</li> </ul>
Main elements to be conserved	<ul style="list-style-type: none"> <li>• Agricultural lands</li> <li>• Pisco urban area</li> </ul>
Basic measures	<ul style="list-style-type: none"> <li>• Construct a dike on the non-protected section</li> <li>• Bank protection works</li> </ul>

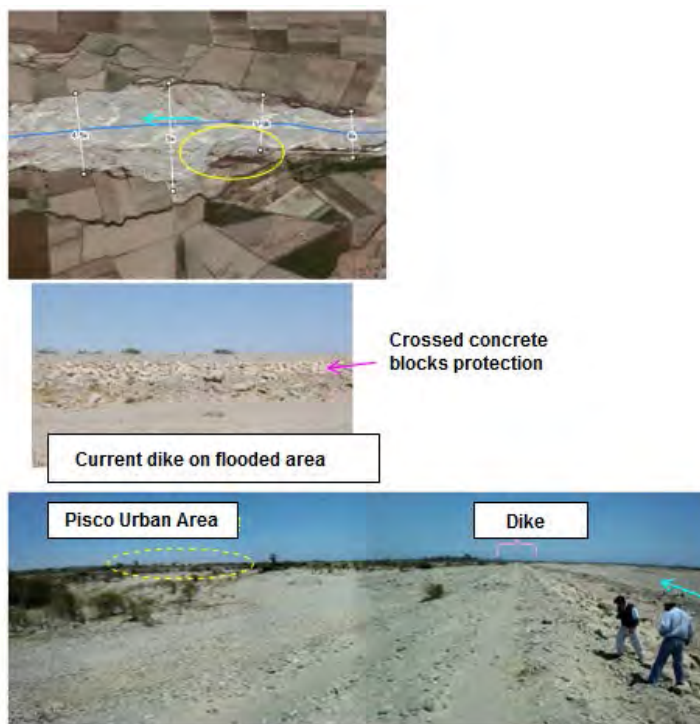

**Figure 3.1.6-2 Local conditions related with Challenge 1 (Pisco River)**



2) Challenge 2: Intake (km 26.5)

Current situation and challenges	<ul style="list-style-type: none"> <li>• During El Niño in 1998, the overflow waters gathered on the intake and destroyed it. Also, the channels were buried</li> <li>• Currently, the intake and the channel have been repaired</li> <li>• The river's width to the intake's height is 90meters and is narrower Downstream than upstream (between 250 and 500meters)</li> </ul>
Main elements to be conserved	<ul style="list-style-type: none"> <li>• Agricultural lands (main products are not known currently)</li> </ul>
Basic measures	<ul style="list-style-type: none"> <li>• Rehabilitate destroyed installations and reinforce the existing dike</li> <li>• Stable water flow throughout widening and rehabilitation of channels, buying the necessary lands</li> </ul>

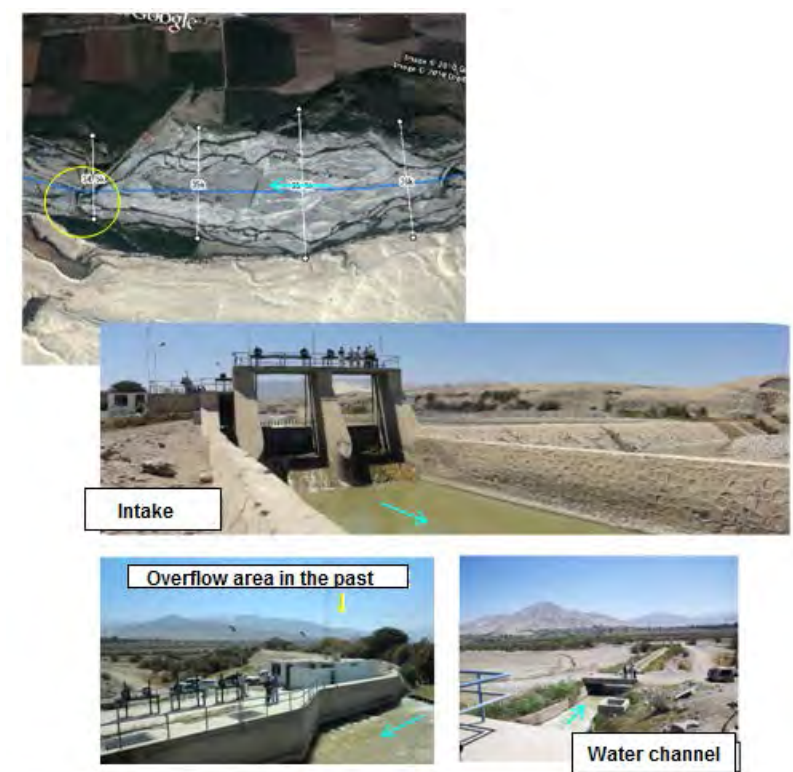

**Figure 3.1.6-3 Local conditions related with Challenge 2 (Pisco River)**



3) Challenge 3: Flooding area (km 34.5)

Current situation and challenges	<ul style="list-style-type: none"> <li>• One time the water has overflow from the right bank, upstream the intake, and this event left several sediments amounts gathered</li> <li>• A dike upstream the intake was built alter the floods</li> </ul>
Main elements to be conserved	<ul style="list-style-type: none"> <li>• Agricultural lands (main product: corn)</li> </ul>
Basic measures	<ul style="list-style-type: none"> <li>• Rehabilitate the intake</li> <li>• Build retardation reservoir upstream the intake (at the upstream of the narrow section, fixing the deposited sediment and for sediment reservation in future)</li> </ul>



**Figure 3.1.6-4 Local conditions related with Challenge 3 (Pisco River)**

### 3.1.7 Current Situation of Vegetation and Reforestation

#### (1) Current vegetation

According to the Forest Map 1995 and its clarification, the basins of the rivers Cañete, Chíncha, Pisco and Yauca extend from the coast to the Andean region, presenting different types of vegetation according to altitude. From the coast to 2,500 m (Cu, DC) is characterized by its low vegetation. Except for the river banks, mainly herbal areas, cactus areas or areas without vegetation extend. In areas somewhat higher, only bushes distribute sparsely. Between 2,500 and 3,500 meters m.a.s.l, bushes develop through rainfall occurring in these areas. Further, the vegetation disappears again due to low temperatures and extend mainly herbal areas. Even in the bushes, the tree maximum height is approximately 4 meters. However, on the riverbanks tall trees grow even in dry areas.

**Table 3.1.7-1 List of representative vegetable forming in the Pisco River watershed**

Symbol	Life Zone	Distribution of Altitude	Rainfall	Representative Vegetation
1)Cu	Coast Crop Lands	Coast	Almost none.	Coastal crops
2)Dc	Coast Desert	0~1,500 m.a.s.l	Almost none, there are mist zones.	Almost none, there are vegetation slopes
3)Ms	Dry Thicket	1,500~3,900 m.a.s.l	120~220mm	Cactus and grass
4)Msh	Subhumid Forest	North-center: 2,900~3,500 m.a.s.l Inter Andean 2,000~3,700 m.a.s.l	220~1,000mm	Perennial bushes, less than 4m high
5)Mh	Humid Forest	North: 2,500~3,400 m.a.s.l South 3,000~3,900 m.a.s.l	500~2,000mm	Perennial bushes, less than 4m high
6)Cp	Puna grass	Approx 3,800 m.a.s.l	No description	Gramineae
7)Pj	Scrubland	3,200~3,300 m.a.s.l Center-South up to 3,800 m.a.s.l	South zone with low rainfall: less than 125mm East springs: higher than 4,000mm	Gramineae
8)N	Ice-capped mountains		—	—

Source: Prepared by the JICA Team based on the Forest Map. 1995

#### (2) Area of vegetation

In the present study we determined the percentage of area occupied by each vegetation type compared to the total area of the basin, overlapping the results of INRENA from 1995 to GIS (see Tables 3.1.7-2 and Figures 3.7. 2-1). Then, we calculated the sum of the areas of each ecological life zone, distinguishing the coastal desert (Cu, Dc), dry scrub (Ms), shrubs (Msh, Mh), and grassland / Puna grass (Cp, Pj .) Table 3.1.7-3 shows the percentage of each ecologic off the whole area of each basin. It is observed that the desert occupies 30% of the total dry scrubland between 10 and 20% grassland / Puna grass between 30 and 50%. The shrubs occupy 10 to 20%. The shrubs are distributed in areas of extremely unfavorable conditions for the development of dense forest, which is why the surface of the brush is not extensive. Thus it follows that the natural conditions in the Pisco Basin. In particular, low rainfall, infertile soil and slope are limiting factors for growth of vegetation, especially tall tree species.

**Table 3.1.7-2 Plant formations on surface opposite to the surface of the basin  
(Pisco River Watershed)**

Watershed	Vegetation Cover								Total
	Cu	Dc	Ms	Msh	Mh	Cp	Pj	N	
(Surface: ha)									
Pisco River	217,88	1.354,39	469,99	381,55	140,01	672,59	1,035,68	0,00	4,272,09
(Percentage of the watershed: %)									
Pisco river	5,1	31,7	11,0	8,9	3,3	15,7	24,2	0,0	99,9

Source: Prepared by the JICA Team based on the INRENA Forest Map of 1995

**Table 3.1.7-3 Percentage of ecological life areas opposite to the surface of the watersheds  
(Pisco River Watershed)**

Watershed	Ecologic areas					Total
	Desert, etc. (Cu, Dc)	Dry bushes (Ms)	Bushes (Msh, Mh)	Grass (Cp, Pj)	Snow (N)	
(Percentage of the watershed: %)						
Pisco	36.8	11.0	12.2	40.0	0.0	100.0

Source: Prepared by the JICA Team based on the INRENA Forest Map of 1995

### (3) Forest area variation

Although a detailed study on the variation of the forest area in Peru has not been performed yet, the National Reforestation Plan Peru 2005-2024, Annex 2 of INRENA shows the areas deforested per department until 2005. These areas subject matter of this study are included in the regions of Arequipa, Ayacucho, Huancavelica, Ica, Lima and Piura, but they only belong to these regions partially. Table 3.1.7-4 shows the lost forest surface (total accumulated) of the corresponding areas. There is no data corresponding to Ica department

**Table 3.1.7-4 Area deforested until 2005**

Department	Area (ha)	Area deforested accumulated (ha) and the percentage of such area in the department area (%)	Post-Felling Situation	
			Non used Area (ha)	Used area(ha)
Ica	2.093.457	-	-	-

Source: National Reforestation Plan, INRENA, 2005

The variation of the distribution of vegetation was analyzed per watershed, comparing the from the FAO study performed in 2005 (prepared based on satellite figures from 2000) and the results of the 1995 INRENA study (prepared base on satellite figures from 1995). (See Table 3.1.7-5).

By analyzing the variation of the surface of each vegetation type, we can see that vegetation in dry areas has reduced (desert and cactus: Cu, DC, and Ms) and bushes increased (Msh, Mh).

**Table 3.1.7-5 Changes in the areas of distribution of vegetation from 1995 to 2000**

Watershed	Formaciones vegetales								
	Cu		Cu		Cu		Cu		Cu
(Surface of the vegetation cover: hectare)									
Pisco	-3.59	-3.44	-50.99	46.88	7.01	-9.52	13.65	—	4,272.09
Current Surface (b)	217.88	1,354.39	469.99	381.55	140.01	672.59	1,035.68	0.00	4,272.09
Percentage of current surface (a/b) %	-1.6	-0.3	-10.8	+12.3	+5.0	-1.4	+1.3	—	

Source: Prepared by the JICA Study Team based on the studies performed by the INRENA 1995 and FAO 2005

## (2) Current situation of forestation

In low and middle basins, trees are planted mainly for three purposes: 1) reforestation along the river for disaster prevention, ii) to protect farmland from wind and sand, and iii) as perimeter fences for houses. In any case, the surface is extremely low. The species most commonly planted is eucalyptus, and follows Casuarinaceae. It is very uncommon the use native species. On the other hand, in the Andean highlands, reforestation for the production of firewood takes place, agricultural land protection (against the cold and the entry of livestock) and for the protection of aquifer recharge areas. The most planted species are eucalyptus and pine. Many reforestation projects in the Andean highlands have been executed in the framework of PRNAMACHIS (now AgroRural). This program involves the delivery of seedlings to the agro-rural community, which are planted and managed by farmers. There is also a reforestation program implemented by the regional government, but of reduced magnitude. In this case, the program states that the need for community consensus for the selection of areas to be reforested. But generally, most farmers want more land to cultivate, and delay in reaching consensus to undertake reforestation. Another limiting factor is the cold weather at altitudes of 3,800 meters or more. Overall, it has been almost been able to collect information on reforestation projects implemented to date, since the files were not available due to the process of institutional reform.

The National Reforestation Plan (INRENA, 2005) shows the data of reforestation carried out between 1994 and 2003 according to departments (former administrative division). We extracted data from the former departments that are included in this study (Table 3.1.7-6). It is observed that the reforested area increased in 1994, and then decreased drastically.

**Table 3.1.7-6 Forestation carried out between 1994-2003**

(Units: ha)

Department	1994	1995	1996	1997	1998	1999	2000	2001	2002	2003	Total
Ica	2,213	20	159	159	89	29	61	15	4	1	2,750

Source: National Reforestation Plan, INRENA, 2005

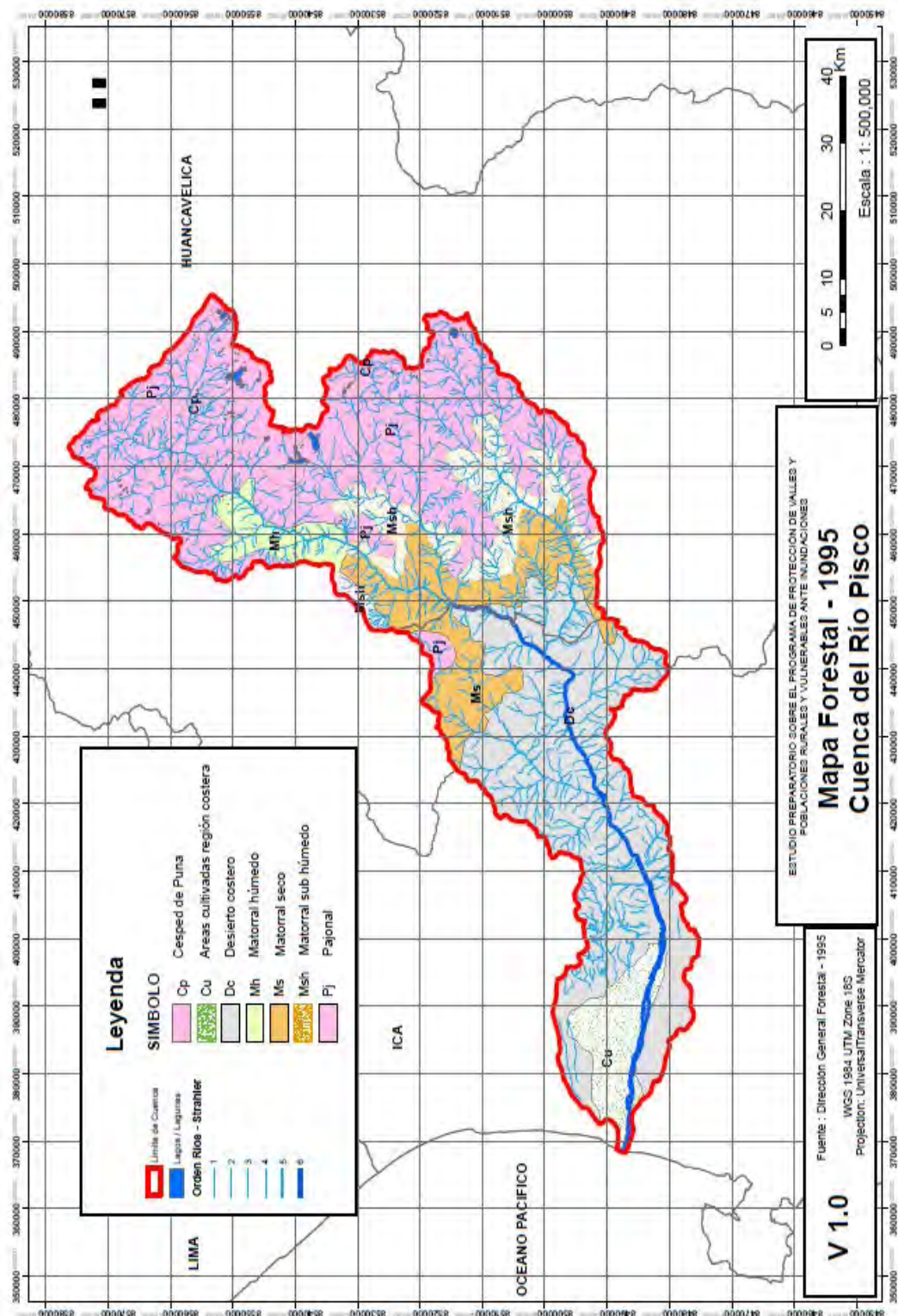

Table 3.1.7-1 Forestation map of Pisco river watershed

### 3.1.8 Current Situation of the Soil Erosion

#### (3) Information gathering and basic data preparation

##### 1) Information Gathering

During this study the data and information indicated in Table 3.1.8-1 was collected in order to know the current situation of the sediment production behind the Study Area.

**Table 3.1.8-1 List of collected information**

	Forms	Prepared by:
Topographic map (Scale 1/50.000)	Shp	INSTITUTO GEOGRAFICO NACIONAL
Topographic map (Scale 1/100.000)	Shp,dxf	INSTITUTO GEOGRAFICO NACIONAL
Topographic map (Scale 1/250.000)	SHP	Geologic data systems
Topographic map (Scale 1/100.000)	Shock Wave	INGEMMET
30 m grid data	Text	NASA
River data	SHP	ANA
Watershed data	SHP	ANA
Erosion potential risk map	SHP	ANA
Soils map	SHP	INRENA
Vegetal coverage map	SHP2000 PDF1995	DGFFS
Rainfall data	Text	Senami

##### 2) Preparation of basic data

The following data was prepared using the collected material. Details appear in Annex 6.

- Hydrographic watershed map (zoning by third order valleys)
- Slope map
- Geological Map
- Erosion and slope map
- Erosion and valley order map
- Soil map
- Isohyets map

#### (4) Analysis of the causes of soil erosion

##### 1) Topographic characteristics

i) Surface pursuant to altitudes

Table 3.1.8-2 and Figure 3.1.8-1 show the percentage of surface according to altitudes of Pisco River watershed.



**Table 3.1.8-2 Surface according to altitude**

Altitude (m.a.s.l)	Area ( Km <sup>2</sup> )
	Pisco
0 – 1000	694,58
1000 – 2000	476,7
2000 – 3000	684,78
3000 – 4000	760,47
4000 – 5000	1647,8
5000 – Más	6,19
TOTAL	4270,52
Maximum altitude	5110,00

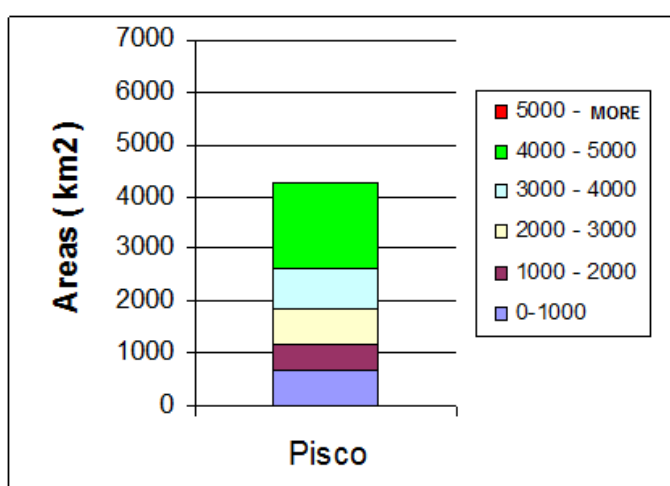

**Figure 3.1.8-1 Surface according to altitude**

ii) Zoning according to slopes

Table 3.1.8-3 and Figure 3.1.8-2 show the slopes in each watershed.

**Table 3.1.8-3 Slopes and surface**

Watershed slope ( % )	Pisco	
	Area (km <sup>2</sup> )	Percentage
0 – 2	869,75	5%
2 – 15	6210,54	36%
15 – 35	5452,97	32%
More than 35	4516,25	26%
TOTAL	17049,51	100%

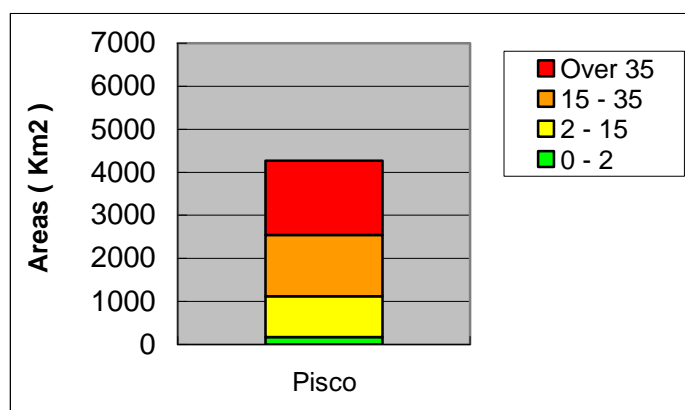

**Figure 3.1.8-2 Slopes and surface**

iii) River-bed slope

Table 3.1.8-4 and Figure 3.1.8-3 show the slope in every river and the length of streams including tributaries. Figure 3.1.8-4 shows the general relation of the movement of sediments and the river-bed slope. Supposedly, sections with more than 33,3 % of slope tend to produce higher amount of sediments, and hillsides with slopes between 3,33 % and 16,7 %, accumulate sediments easier.

**Table 3.1.8-4 River-bed slope and total length of stream**

River-bed slope (%)	Pisco
0,00 - 1,00	12,15
1,00 - 3,33	165,05
3,33 - 16,67	1683,15
16,67 - 25,00	519,64
25,00 - 33,33	291,84
33,33 - More	511,76
<b>TOTAL</b>	<b>3183,59</b>

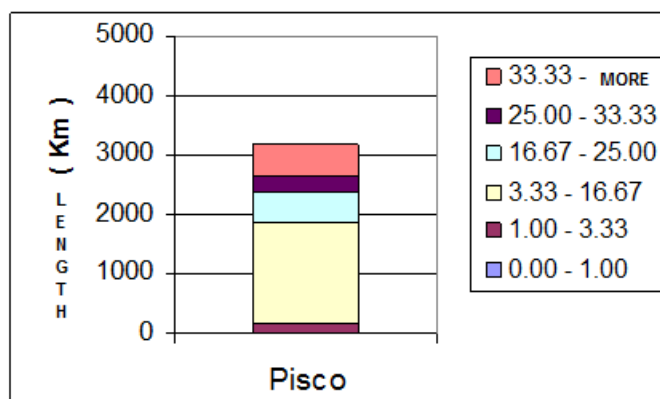

**Figure 3.1.8-3 River-bed slope and total length of streams**



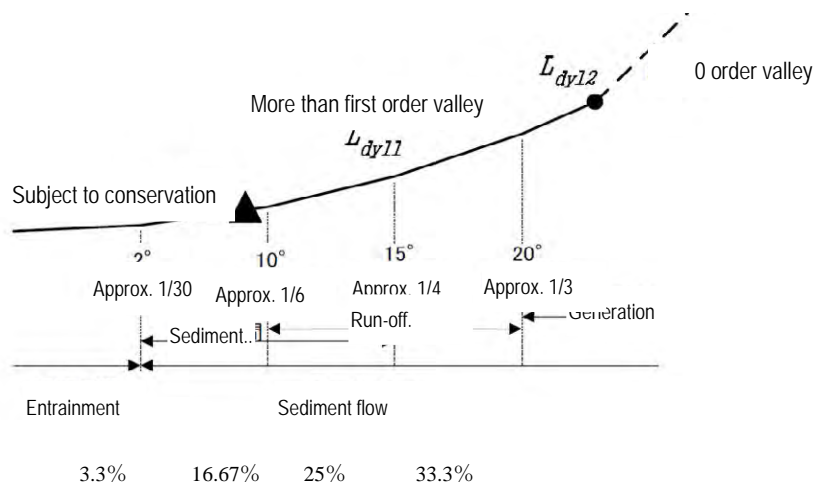

**Figure 3.1.8-4 River-bed slope and sediment movement pattern**

**2) Rainfall**

In the Pacific coast there is an arid area (Coast) of between 30 and 50 km wide and approx. 3,000 km long. This region belongs to the Chala climate area where the average annual temperature is around 20 ° C, and almost no rain throughout the year.

Altitudes between 2,500 and 3,000 m belongs to the Quechua climate, where annual rainfall is between 200 and 300 mm. Beyond this area, between altitudes of 3,500 and 4,500 meters lies a natural region called Suni, characterized by its sterility. Rainfall of 700 mm occurs annually in this region.

Figure 3.1.8-4 shows the isohyetal maps (annual rainfall) of the Pisco River basin.

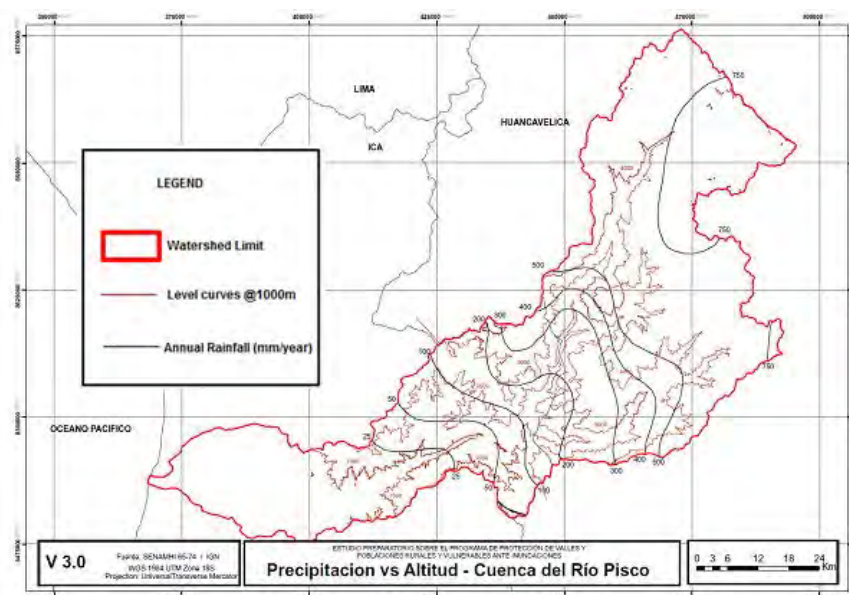

Source: Prepared by the JICA Study Team based on the SENAMHI data

**Figure 3.1.8-5 Isohyet map of the Pisco river watershed**

Annual rainfall in the area subject to flooding analysis range from 0 to 25 mm. The average annual rainfall in the area of 4000 m in the northern part between 500 and 750 mm.

### 3)Erosion

The characteristics of erosion of the watershed in general are presented below. This is divided in three large natural regions: Coast (Area A), Mountain/Suni (Area B), and Puna (Area C). Figure 3.1.8-6 shows the corresponding weather and the rainfalls. It is observed that the area most sensitive to erosion is Mountain/Suni where the pronounced topography without vegetal coverage predominates.

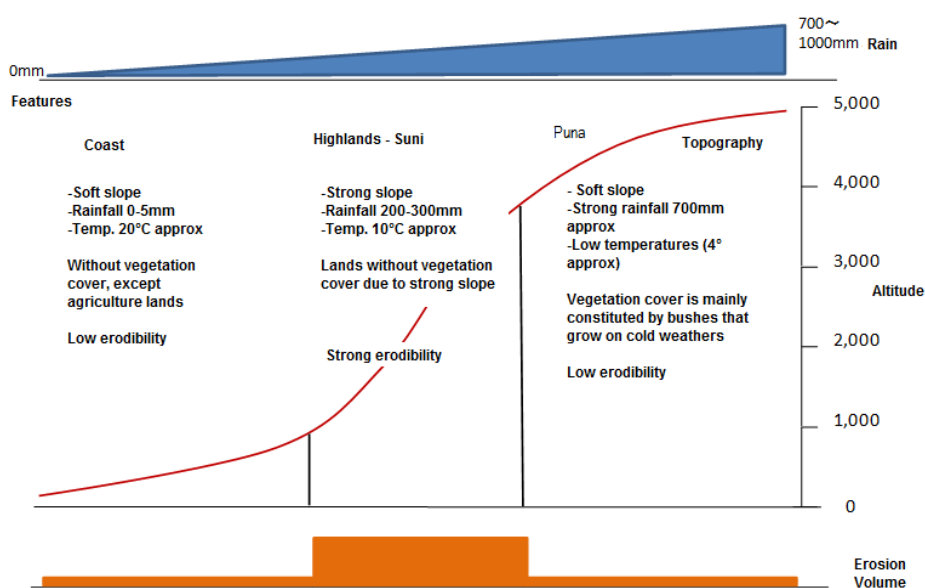

**Figure 3.1.8-6 Relation between the erosion volume and the different causes**

#### (5) Identification of the zones more vulnerable to erosion

The erosion map prepared by ANA considers the geology, hill sloping and rainfalls. Supposedly, the erosion depth depends on the hillside slope, and in such sense the erosion map and the slope map are consistent. Thus, it is deduced that the zones more vulnerable to erosion according to the erosion map are those where most frequently erosion happens within the corresponding watershed.

Between 1,000 and 4,000 m are numerous slopes over 35 % of tilt, particularly between 2,000 and 3,000 m, 79% of the slopes are of these inclinations, and we can say that areas very susceptible to erosion.

**Table 3.1.8-5 Slopes according to altitudes of Pisco river**

Altitude	SLOPES				Total
	0-2	2 - 15	15 - 35	More than	
0 - 1000	132.09	371.35	118.98	60.92	683.34
Ratio	19%	54%	17%	9%	100%
1000 - 2000	1.79	25.01	107.69	373.82	508.31
Ratio	0%	5%	21%	74%	100%
2000 - 3000	2.08	23.33	101.38	479.29	606.08
Ratio	0%	4%	17%	79%	100%
3000 - 4000	3.58	67.75	230.25	415.34	716.92
Ratio	0%	9%	32%	58%	100%
4000 - 5000	33.74	459.43	856.43	398.45	1748.05
Ratio	2%	26%	49%	23%	100%
5000 - More	0.02	1.51	4.06	3.8	9.39
Ratio	0%	16%	43%	40%	100%
Total	173.30	948.38	1418.79	1731.62	4272.09
Ratio	4%	22%	33%	41%	100%

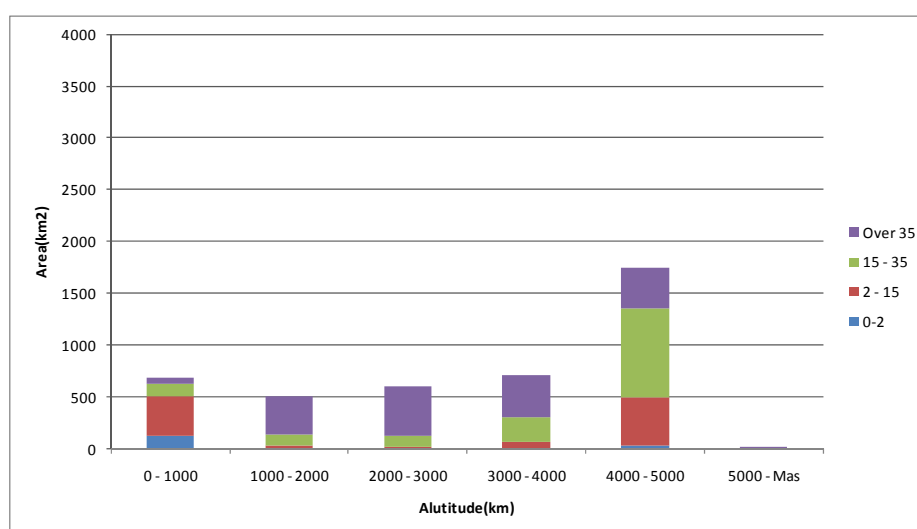

**Figure 3.1.8-7 Slopes according to altitudes in Pisco River**

## (6) Production of sediments

### 1) Results of the field investigation

The field investigation was conducted to study the upper basin of Pisco. Here are the results of the study.

- At mountain slopes the formation of clastic material released by the collapse or wind erosion.
- Production patterns differ depending on the geology of the rock base. If the rock is andesite or basalt basis, the mechanism consists mainly of large gravel falling and fracturing (see Figure 3.1.8-8 and Figure 3.1.8-9).
- Rooted vegetation is not observed (Figure 3.1.8-10) probably due to sediment transport in ordinary time. In the joints of the rock layer andesite, etc. where little sediment movement occurs, there has been the development of algae and cactus.

- In almost every the channel we observed the formation of the lower terraces. In these places, the sediment washed from the slopes does not directly enter the channel, but are deposited on the terrace. For this reason, most of the sediment entering the river, probably supplied by the eroded terraces deposits or sediments accumulated due to the alteration of the bed (see Figure 3.1.8-11).
- In the upper terraces and there was less sediment washed from the slopes fall directly into the river, although its amount is extremely small.



**Figure 3.1.8-8 Crumbled andesitic and basaltic land**

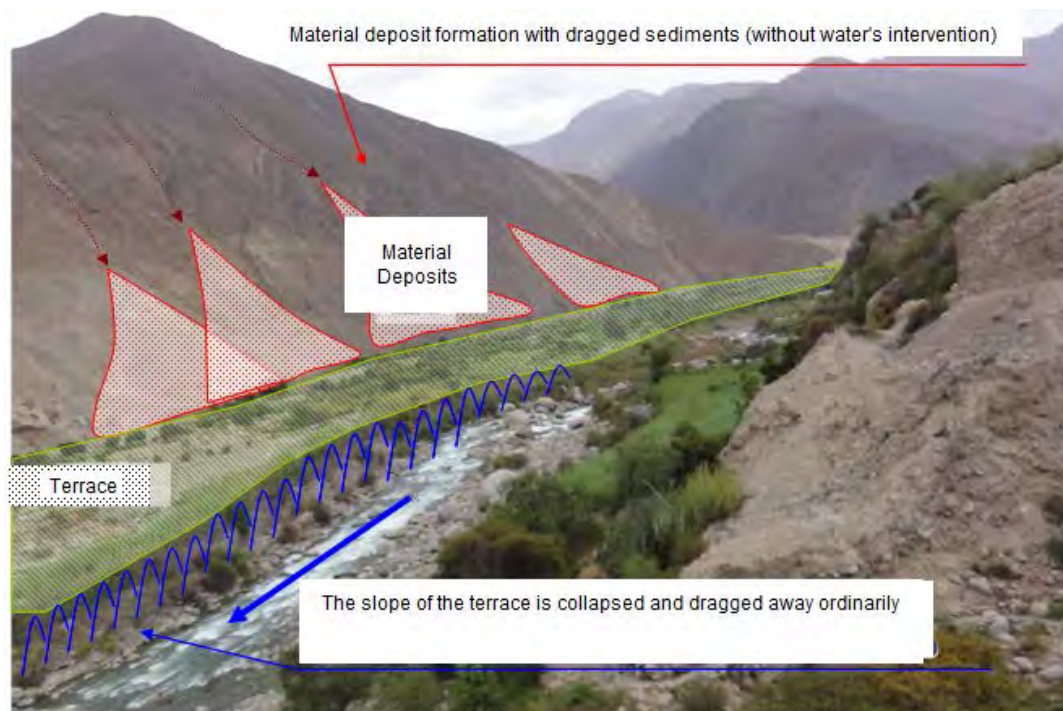

**Figure 3.1.8-9 Sediment production of sedimentary rocks**



**Figure 3.1.8-10 Cactus invasion**





**Figure 3.1.8-11 Sediment movement in the stream**

## **2) Movement of sediments (in the stream)**

In the ravines terraces develops (over 10 m high in the Pisco Basin). The base of these terraces is contacted directly with the channels and from these places the sediments are again washed and transported with a regular flow (including small and medium floods in the rainy season).

## **3) Production forecast and sediments entrainment**

It is expected that the amount of sediment production and entrainment will vary depending of the dimension of factors such as rainfall, volume of flow, etc.

Since a quantitative sequential survey has not been performed, nor a comparative study, here we show some qualitative observations for an ordinary year, a year with a rainfall similar to that of El Niño and one year with extraordinary overflow. The scope of this Study is focused on a rainfall with 50 year return period, as indicated in the Figure below, which is equivalent to the rainfall producing the sediment flow from the tributaries.

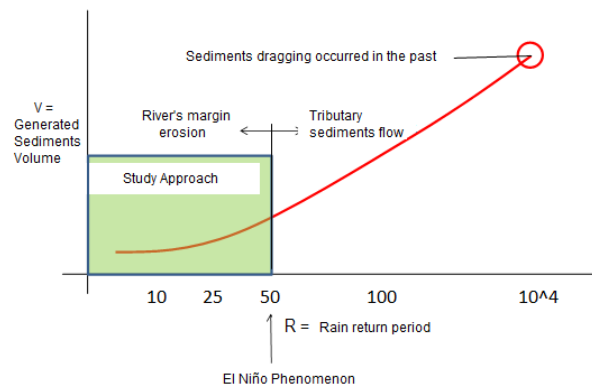

i) An ordinary year

- Almost no sediments are produced from the hillsides
- Sediments are produced by the encounter of water current with the sediment deposit detached from the hillsides and deposited at the bottom of terraces
- It is considered that the entrainment is produced by this mechanism: the sediments accumulated in the sand banks within the bed are pushed and transported downstream by the bed change during low overflows (see Figure 3.1.8-12)

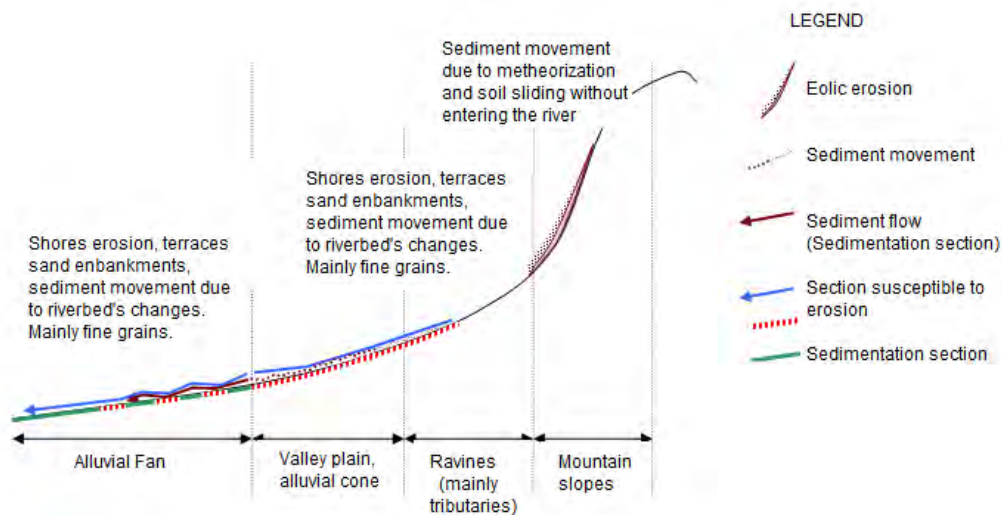

**Figure 3.1.8-12 Production and entrainment of sediments in an ordinary year**

ii) When torrential rains with magnitude similar to that of the El Niño happen (50 years return period)

Pursuant to the interviews performed in the locality, every time El Niño phenomenon occurs the tributary sediment flow occurs. However, since the bed has enough capacity to regulate sediments, the influence on the lower watershed is reduced.

- The amount of sediments entrained varies depending on the amount of water running by the hillsides
- The sediment flow from the tributaries reaches to enter to the main river
- Since the bed has enough capacity to regulate the sediments, the influence in the watershed is

reduced

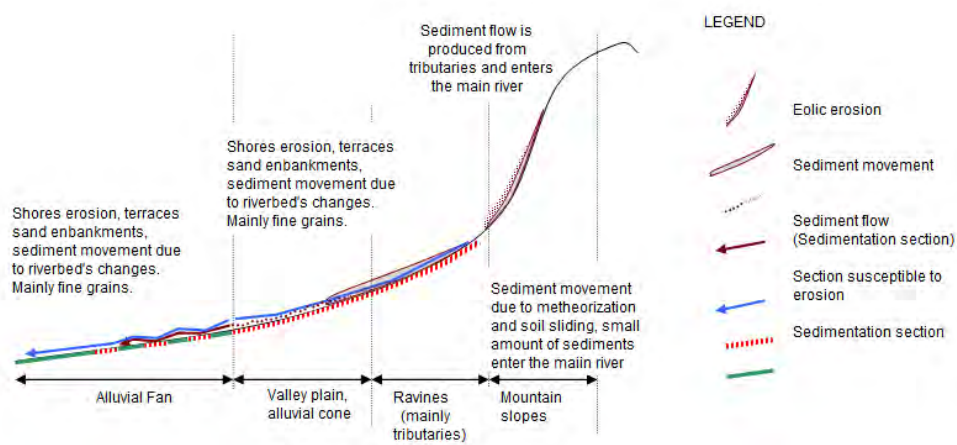

**Figure 3.1.8-20 Production and entrainment of sediments during the torrential rainfall of magnitude similar to that of El Niño (1:50 year return period)**

iii) Large magnitude overflows (which may cause the formation of terraces similar to those existing now), with once a few thousand years

In the coast, daily rainfall with 100 years of probability are approximately 50 mm, so land slides entrained by water scarcely occur currently. However, precisely since there are few rains, when torrential rainfall occurs, there is a high potential of water sediment entrainment.

If we suppose that rainfall occurs with extremely low possibilities, for example, once a few thousands years, we estimate that the following situation would happen (see Figure 3.1.8-14).

Sediment entrainment from hillsides, by the amount congruent with water amount

Exceeding sediment entrainment from the bank and bottom of hillsides by the amount congruent with the water amount, provoking landslides which may close streams or beds

Destruction of the natural embankments of beds closed by the sediments, sediment flow by the destruction of sand banks

Formation of terraces and increase of sediments in the beds of lower watershed due to the large amount of sediments

- Overflowing in section between alluvial cone and critical sections, which may change the bed.

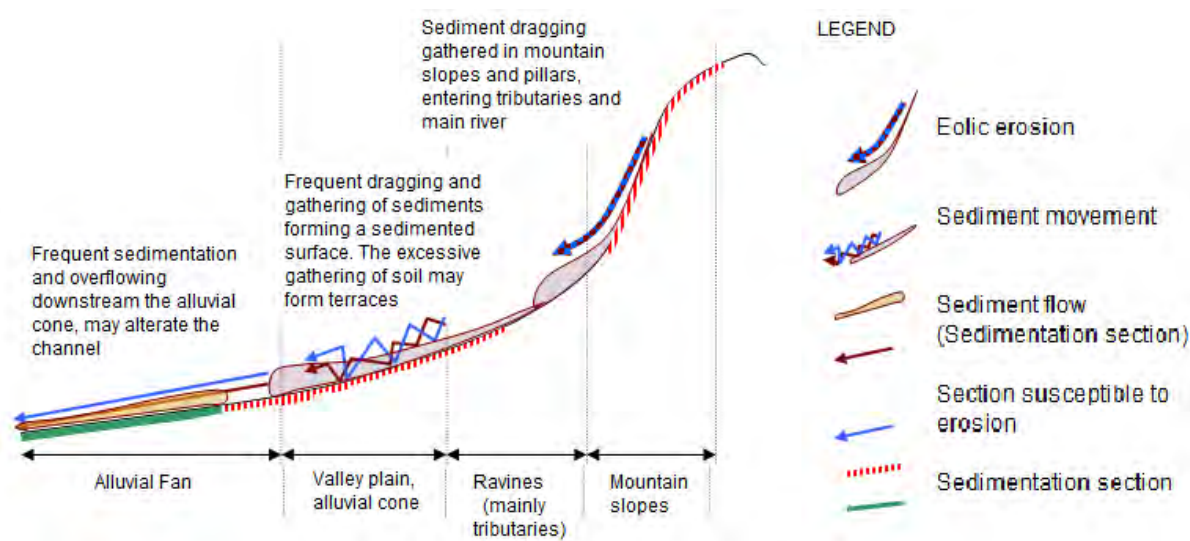

**Figure 3.1.8-21 Production of sediments in large overflowing (geologic scale)**

### 3.1.9 Run-Off Analysis

The run-off study in the study area is described as follows. For further detail of Meteorology/Hydrology and Run-off study, refer to the Annex-1 Meteorology/Hydrology and Run-off Study.

#### 3.1.9.1 Rainfall

The rainfall data is collected and processed in order to obtain the observation conditions of rainfall data in the study area, which are to be used in the run-off study. The rainfall data is collected mainly from SENAMHI which is the observation agency of the most of the stations. The observation method is not automatic but manual at regular time of a day for all of the stations in the study area so that there is no hourly data but only daily data (24 hour -rainfall data).

##### (1) Conditions of rainfall observation

The rainfall observation stations and their observation period in Pisco basin are as shown in the Table-3.1.9.1-1 ~ Table-3.1.9.1-2 and the Figure-3.1.9.1-1.

In Pisco basin, the rainfall has been observed in 20 stations, and the longest observation period is 39 years from 1964 to 2002.



**Table-3.1.9.1-1 Rainfall observation station (Pisco river)**

Code No.	Observation Station	Region	Longitude	Latitude	Responsible Agency
646	AGNOCOCHA	HUANCVELICA	75° 05'1	13° 13'1	SENAMHI
156130	CHOCLOCOCHA	HUANCVELICA	75° 02'1	13° 06'1	
643	COCAS	HUANCVELICA	75° 22'1	13° 16'1	
156121	CUSICANCHA	HUANCVELICA	75° 18'18	13° 29'29	
156131	PARIONA	HUANCVELICA	75° 04'1	13° 32'1	
156114	SAN JUAN DE CASTROVIRREYNA	HUANCVELICA	75° 38'38	13° 12'12	
156122	TAMBO	HUANCVELICA	75° 16'16	13° 41'41	
156117	TICRAPO	HUANCVELICA	75° 26'1	13° 23'1	
156119	TOTORA	HUANCVELICA	75° 19'1	13° 07'1	
647	TUNEL CERO	HUANCVELICA	75° 05'5	13° 15'15	
650	HACIENDA BERNALES	ICA	75° 57'57	13° 45'45	
640	HUAMANI	ICA	75° 35'35	13° 50'50	

**Table-3.1.9.1-2 Observation period of rainfall data (Pisco river)**

Observation Station	1980	1981	1982	1983	1984	1985	1986	1987	1988	1989	1990	1991	1992	1993	1994	1995	1996	1997	1998	1999	2000	2001	2002	2003	2004	2005	2006	2007	2008	2009	2010
AGNOCOCHA																															
CHOCLOCOCHA																															
COCAS																															
CUSICANCHA																															
PARIONA																															
SAN JUAN DE CASTROVIRREYNA																															
TAMBO																															
TICRAPO																															
TOTORA																															
TUNEL CERO																															
HACIENDA BERNALES																															
HUAMANI																															

: year of El niño

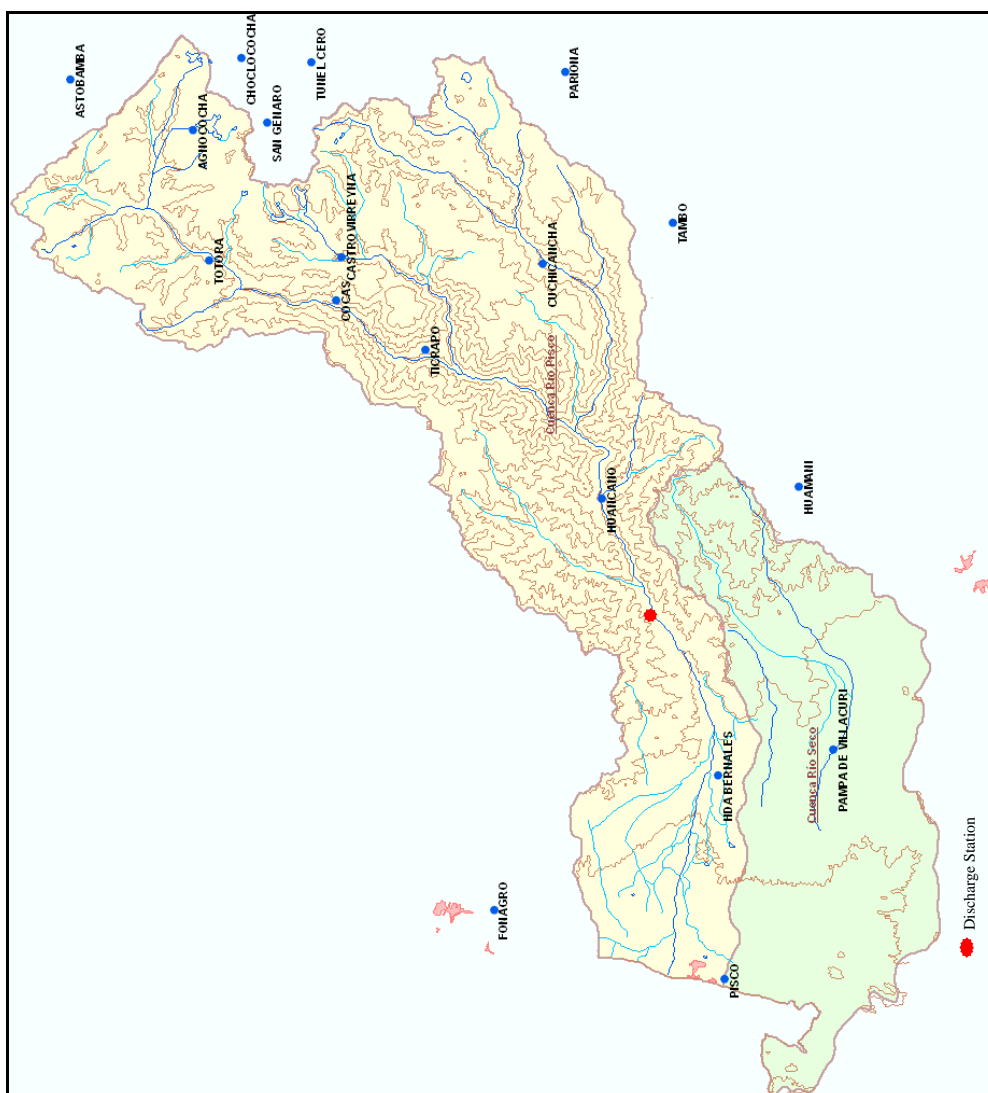

**Figure-3.1.9.1-1 Location of rainfall and discharge observation station (Pisco river)**

## 2) Monthly rainfall

The average monthly rainfall and its distribution of each station in Pisco basin are as shown in Table-3.1.9.1-3 and the Figure-3.1.9.1-2.

According to the Table and the Figure, the monthly rainfall is large from October to April and extremely small from May to September. And the yearly rainfall varies from 2.93mm in Hacienda Bernales to 884mm in Choclococha .

**Table - 3.1.9.1-3 Average monthly rainfall in Chinchá basin and adjacent basin (mm)**

Observation Station	Month												Total
	Jan.	Feb	Mar	Apr	May	June	Juyl	Aug.	Sep	Oct	Nov	Dec	
ACNOCOCHA	139.08	145.04	129.35	56.57	17.74	8.18	5.65	13.73	21.69	40.59	52.30	83.59	713.51
CHOCLOCOCHA	147.66	161.73	156.09	80.13	26.52	14.25	8.03	22.18	35.24	59.48	68.69	103.97	883.97
COCAS	94.93	111.50	138.93	29.87	5.31	0.26	0.36	1.54	6.70	11.83	15.36	40.73	457.31
CUSICANCHA	74.40	88.26	104.57	33.77	1.74	0.00	0.01	0.71	3.48	4.85	12.38	36.37	360.55
PARIONA	161.82	155.42	174.45	68.15	13.61	3.06	3.12	4.02	16.39	32.52	54.23	90.91	777.70
SAN JUAN DE CASTROVIRREYNA	49.69	54.27	46.95	8.78	0.96	0.09	0.17	0.67	0.95	3.50	7.06	19.24	192.34
TAMBO	82.19	120.28	130.42	32.03	3.95	0.00	0.12	0.51	0.88	9.53	11.48	40.40	431.78
TICRAPO	54.24	75.45	73.35	14.10	0.44	0.20	0.03	0.45	0.98	3.99	5.05	24.32	252.60
TOTORA	125.39	133.76	104.56	46.33	18.20	4.07	4.90	7.76	24.24	32.59	41.47	81.67	624.95
TUNEL CERO	163.61	162.53	150.68	72.29	20.96	7.59	6.98	14.51	29.20	56.12	72.29	121.55	878.32
HACIENDA BERNALES	0.84	1.50	0.05	0.03	0.07	0.14	0.08	0.08	0.02	0.01	0.03	0.09	2.93
HUAMANI	3.08	3.75	3.45	0.05	0.00	0.00	0.01	0.00	0.08	0.00	0.00	0.17	10.60

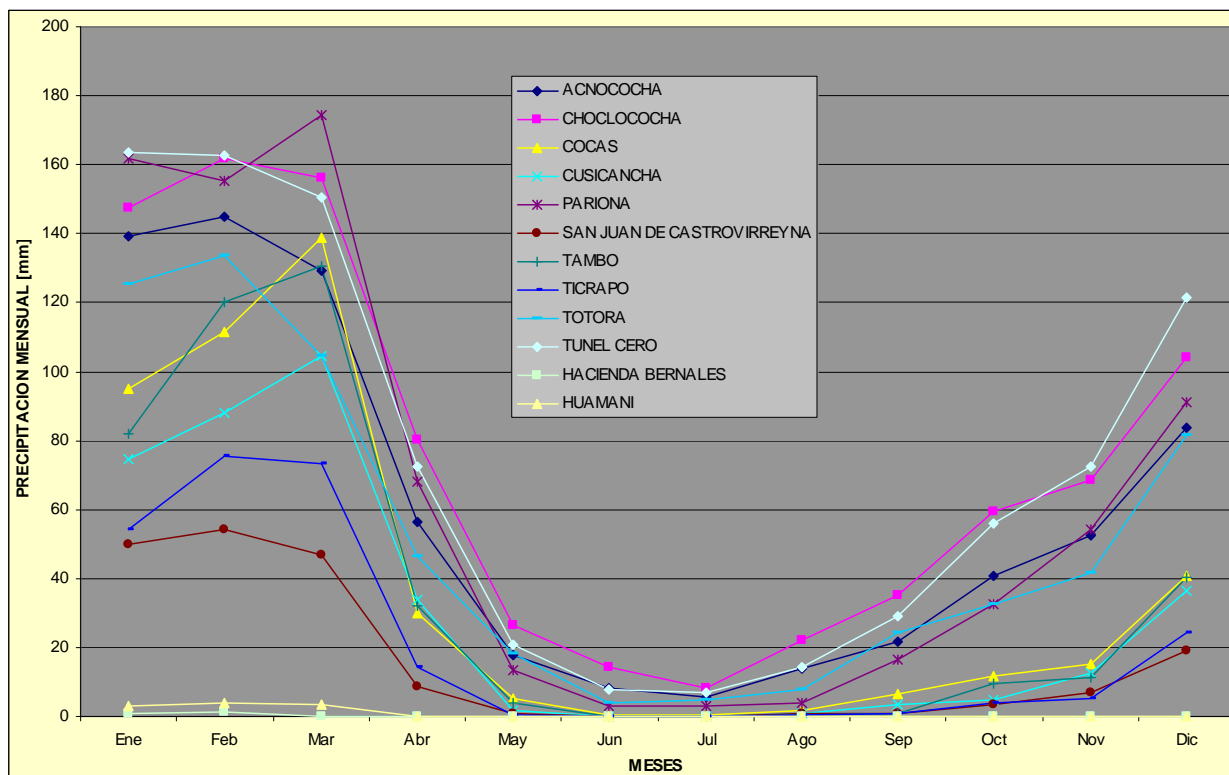

**Figure - 3.1.9.1-2 Distribution of average monthly rainfall in Pisco Basin and adjacent basin (mm)**

### 3) Yearly Maximum of 24-hour Rainfall

The yearly maximum of 24-hour rainfall (daily rainfall) of each observation station in Pisco basin is as shown in the Table-3.1.9.1-4.

**Table-3.1.9.1-4 Yearly maximum of 24-hour rainfall (daily rainfall) in Pisco basin (mm)**

Year	ACNOCOC HA	CHOCLOC OCHA	COCAS	CUSICANC HA	PARIONA	SAN JUAN DE CASTROVI RREYNA	TAMBO	TICRAPO	TOTORA	TUNEL CERO	HACIENDA BERNALES	HUAMANI
1964			19.8					21.5				
1965			21.6				35.0	20.7				
1966			20.2	18.7				12.6	15.0			
1967			36.0	23.5		20.1		24.4	24.0			25.5
1968				12.3			24.0	10.0	20.0			0.0
1969				23.0				35.8	22.0			1.6
1970			22.1	25.3		33.3	13.3	40.2	23.0			33.5
1971	32.3		29.4	28.6		13.7	18.2	28.4	21.0	30.7		1.7
1972	29.2		30.8	26.9	40.0	28.0	30.7	32.0	27.0	28.2	29.5	18.8
1973	24.6		36.8	13.1	37.8	23.0			25.0	34.6	1.6	2.1
1974	31.1		20.6	9.7	36.9	12.1	21.0	14.0	22.0	24.2	0.0	4.1
1975	24.1	27.4	22.4	6.6	39.1	17.0	42.4	19.5	19.0	29.2	0.0	23.0
1976	26.4	36.1	21.4	6.6	34.4	17.2	40.0		20.0	22.8	20.8	12.5
1977	26.9		20.6	24.2	29.7	15.5	20.5	24.0	25.0	31.3	0.0	0.0
1978	28.1	22.9	14.4	20.0	20.6	7.8	32.0	5.4	20.0	19.5	0.6	0.0
1979	22.3	15.4	27.4		25.4	21.6	20.4	18.0	25.0	33.2	0.0	0.2
1980	23.0	14.8		19.0	44.4	40.0	21.2		35.0	27.3	0.0	0.3
1981	22.6	13.5	0.0	20.0	28.5		25.6	33.0	29.0	35.9		0.0
1982	32.1			10.1		17.1	15.7	10.9	29.0	52.2		0.0
1983	30.1	26.5		5.0		28.0	35.0	30.0	24.0		0.0	0.0
1984	28.7			20.0		24.0	40.0	20.8	37.0	38.3	0.0	0.4
1985	26.5	19.0		11.0	26.5	11.5	30.0	18.0	30.0	22.7	0.0	7.5
1986	29.2	36.0				14.7	30.0		27.0	35.3	0.0	
1987	22.4	24.4			14.8	12.3	20.0		13.0	23.1	0.0	0.0
1988	26.9	39.1			28.0	13.5	17.0			27.8	0.0	
1989	20.3					31.8	36.7			31.9	0.0	0.0
1990		39.5				13.1	29.0			54.5	0.0	
1991						11.0	40.0				0.0	0.0
1992												
1993		39.3				13.7				36.5	0.0	
1994		37.3				12.3	22.0			30.5	0.0	
1995		28.1				12.0	43.2			26.2	0.0	
1996		35.9				19.2	42.0			27.3	0.0	
1997		67.5				10.5	30.0			21.6	0.0	
1998		55.5				37.9	40.0			25.1	0.0	
1999		34.4				25.0	23.0			26.1	0.5	
2000		38.0				18.8	26.0				0.3	2.5
2001		29.3				23.2	16.0			29.6	1.3	2.2
2002		30.7				19.5				23.7	0.5	3.1
2003		57.7				10.5	22.0			27.4	0.0	2.7
2004		45.0				10.3	16.0			28.7	0.4	0.0
2005		36.1				16.1	27.0			47.8	4.6	13.0
2006		36.7				21.4	38.0			25.0	3.2	4.2
2007						18.4	16.5			35.8		0.0
2008		24.6				14.5	26.0			28.6	5.1	6.2
2009		58.4				17.2	38.0			36.2	1.3	8.3
2010												

### 4) Isohyetal map of yearly average rainfall

The isohyetal map of yearly average rainfall in Pisco basin is as shown in the Figure-3.1.9.1-3.

There is big difference in the yearly rainfall data by areas in Pisco basin, for instance yearly rainfall is less than 25mm in the minimum, on the other hand 750mm in the maximum, and the amount is small in the downstream area and becomes large toward the upstream with higher elevation.

In the objective section for flood protection, the yearly rainfall is not so much from 25~50mm.

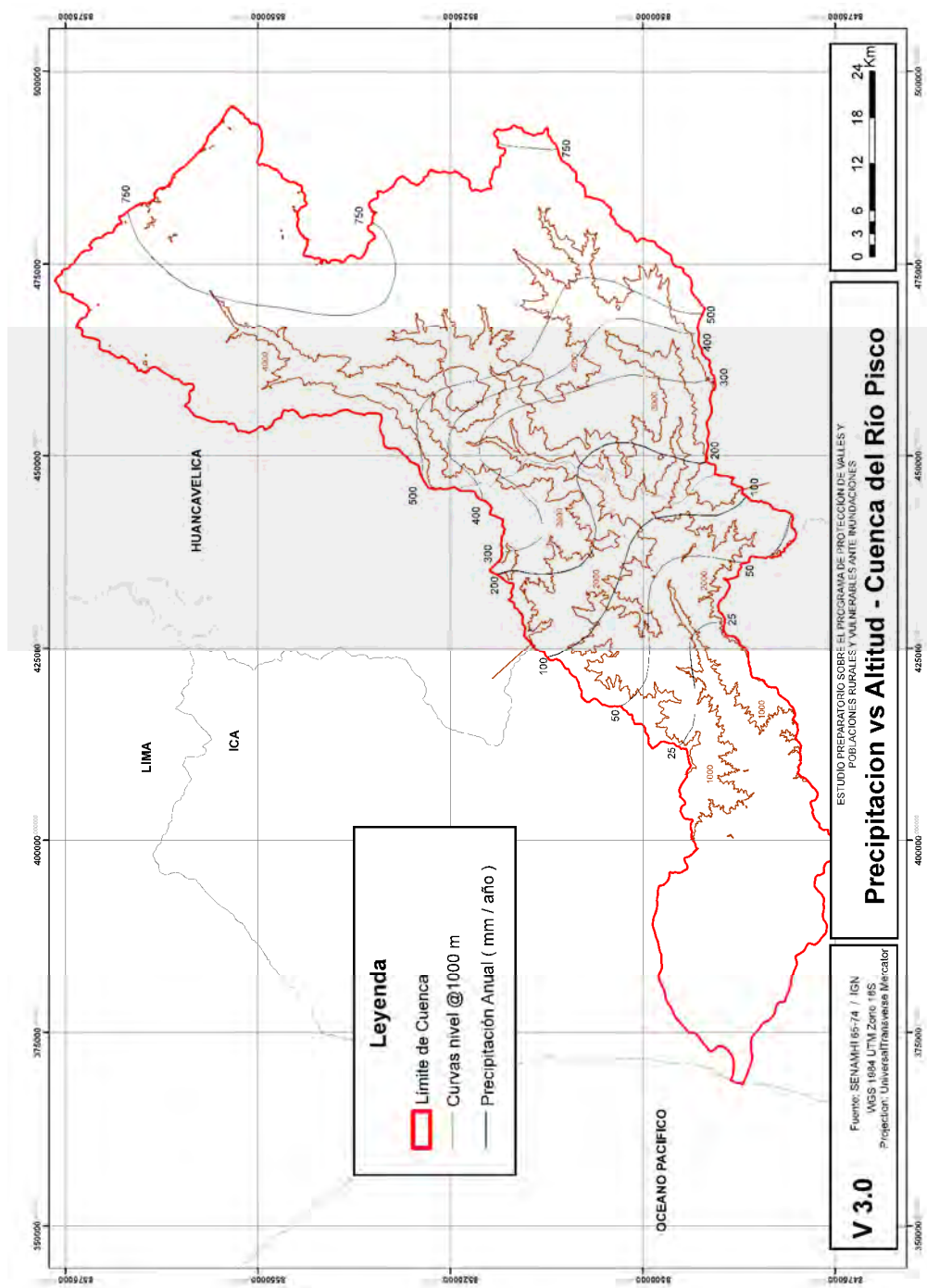

Figure-3.1.9.1-3 Isohyetal map of yearly rainfall (Pisco Basin )

### 3.1.9.2 Discharge

The discharge observation method is not automatic but manual at regular time of a day, once a day at 7 a.m. or twice a day at 7a.m. and 7p.m. for all of the stations in the study area so that there is no hourly data but only daily data (24 hour -discharge data). Therefore instantaneous maximum discharge such as the flood peak discharge is not observed.

The water level is observed by staff gauge, and the discharge is estimated applying the water level to the relation curve between the water level and discharge which is prepared beforehand by actual measurement of flow area and velocity.

The river originates at high land connected with Andes Mountains and flow down through alluvial fan to the coast. The discharge observation stations are generally located at the middle stream or downstream of the alluvial fan (refer to the location map of rainfall observation stations). Since there is hardly rainfall in the coastal area, the discharge will not enter from residual area of downstream basin so that the discharge observation shows the total discharge from the whole basin. Therefore it is desirable to select the reference point for run-off analysis at such observation station.

#### (1) Discharge observation station

The discharge observation station in Pisco River is as shown in the Table-3.1.9.2-1.

**Table-3.1.9.2-1 Discharge observation station (Pisco river)**

<b>Observation Station</b>	<b>Latitude</b>	<b>Longitude</b>	<b>Elevation (m.a.s.l.)</b>
LETRAYOC	13° 40'	75° 45'	640

#### (2) Yearly maximum daily discharge

The yearly maximum daily discharge of each year is as shown in the Table-3.1.9.2-2.

**Table-3.1.9.2-2 Yearly Maximum daily discharge (Pisco river) (m<sup>3</sup>/s)**

<b>Year</b>	<b>Yearly Maximum Daily Discharge</b>	<b>Year</b>	<b>Yearly Maximum Daily Discharge</b>
1933	227.50	1971	194.45
1934	264.50	1972	509.87
1935	311.00	1973	293.62
1936	360.50	1974	194.68
1937	956.03	1975	141.88
1938	253.70	1976	237.62
1939	328.67	1977	231.26
1940	155.34	1978	80.33
1941	212.25	1979	213.13
1942	326.79	1980	91.23
1943	301.93	1981	252.00
1944	295.05	1982	274.00

1945	250.01	1983	273.00
1946	528.14	1984	485.65
1947	144.09	1985	200.50
1948	765.10	1986	355.00
1949	148.26	1987	146.20
1950	156.33	1988	369.50
1951	289.09	1989	272.50
1952	208.05	1990	49.38
1953	427.20	1991	325.00
1954	536.64	1992	47.75
1955	403.42	1993	118.00
1956	330.99	1994	312.50
1957	256.19	1995	354.37
1958	169.35	1996	190.00
1959	378.26	1997	150.00
1960	312.85	1998	800.00
1961	272.04	1999	355.00
1962	423.06	2000	215.00
1963	255.85	2001	240.00
1964	238.45	2002	300.00
1965	162.44	2003	176.25
1966	710.02	2004	215.00
1967	521.91	2005	137.50
1968	189.11	2006	350.00
1969	314.07	2007	250.00
1970	454.31	2008	300.00

### 3.1.9.3 Probable Flood Discharge Based on Observation Data

The reference point for run-off analysis was selected among the observation stations in each basin, and where the flood discharge with return period from 2years to 100 years are calculated based on the observation data of yearly maximum daily discharge by statistical processing. The results of calculation are as shown in the Table-3.1.9.3-1.

The following probable distribution models are used for hydrological statistic calculation, and the most adaptable value among models is adopted for each basin, for further details refer to the Appendix attached at end of this report.

- Distribution Normal or Gaussiana
- Log - Normal 3 parameters
- Log - Normal 2 parameters
- Gamma 2 or 3 parameters
- Log - Pearson III)
- Gumbel Distribution
- Generalized Extreme Values

**Table-3.1.9.3-1 Probable discharge at reference point**

Riiver/Reference Point	Return Period of 2years	Return Period of 5years	Return Period of 10years	Return Period of 25 years	Return Period of 50 years	Return Period of 100 years
Pisco/ Letrayoc	267	398	500	648	774	914

(m<sup>3</sup>/s)

#### **3.1.9.4 Run-off Analysis Based on Rainfall Data (HEC-HMS Method)**

There is only daily discharge data in the objective study area, and the probable discharges calculated in the previous clause 3.1.9.3 show the peak discharge. In order to perform the inundation analysis described later clause, the hourly distribution of flood discharge (flood hydrograph) is required. Therefore the run-off study based on rainfall data is performed in this clause.

The run-off analysis method is to be HEC-HMS (Hydrologic Engineering Center- Hydrologic Modeling System) which is developed by US Army Corps of Engineer. This system is the run-off analysis program for general purpose which is widely used in the north America and other areas in the world, and one of the most popular program in Peru.

##### **(1) Summary of HEC-HMS**

HEC-HMS is designed to simulate the precipitation-runoff processes of dendritic watershed system. The basin model can be composed of sub-basin, reach, junction, diversion, reservoir etc. To simulate infiltration loss options for event modeling include SCS curve number, Initial Constant, Exponential, Green Ampt etc.

Several methods are included for transforming excess precipitation into surface runoff such as unit hydrograph methods including Clark, Snyder, SCS technique. Several methods including Muskingum, kinematic wave can be applied for flood routing in channel. And several methods can be applied for representing base flow contribution to sub-basin outflow.

Six different historical and synthetic precipitation methods are included. Four different methods for analyzing historical precipitation are included. The gage weights method uses an limited number of recording and no-recording gages and Thiessen technique is one possibility for determining the weights.

The frequency storm method uses statistical data to produce balanced storms with a specific exceeding probability. The SCS hypothetical storm method implements the primary distribution for design analysis using Natural Resources Conservation Service Criteria (NRCS). Most parameters for methods included in sub-basin and reach elements can be estimated automatically using optimization trials. Six different objective functions are available to estimate goodness-of-fit between the computed results and observed discharge.



The procedure of applying HEC-HMS in this analysis is as shown below. According to this procedure the summary of run-off analysis on Majes-Camana basin is described below. As to detail of run-off study for the basin refer to Annex-1 Meteorology/Hydrology and Run-off Study, Appendix.

- (1) Preparation of Basin Model
- (2) Rainfall Analysis
  - 1) Calculation of Probable 24-hour Rainfall in Each Station
  - 2) Calculation of 24-hour Rainfall in Each Sub-basin
  - 3) Selection of Type of 24-hour Rainfall Curve
- (3) Calculation of Infiltration Loss by SSC Method
  - 1) Selection of Initial Curve Number in Each Sub-basin
  - 2) Selection of Final Curve Number in Each Sub-basin
  - 3) Verification of Model
- (4) Calculation of Probable Flood Discharges and their Flood Hydrograph

## (2) Preparation of basin model

### 1) Division of Basin

Pisco basin is divided into many sub-basins each of which has similar hydraulic characteristics, such as topography, distribution pattern of river channel, forestation conditions, surface soil conditions etc. The division of the basin is as shown in the Figure .1.9.4-1.

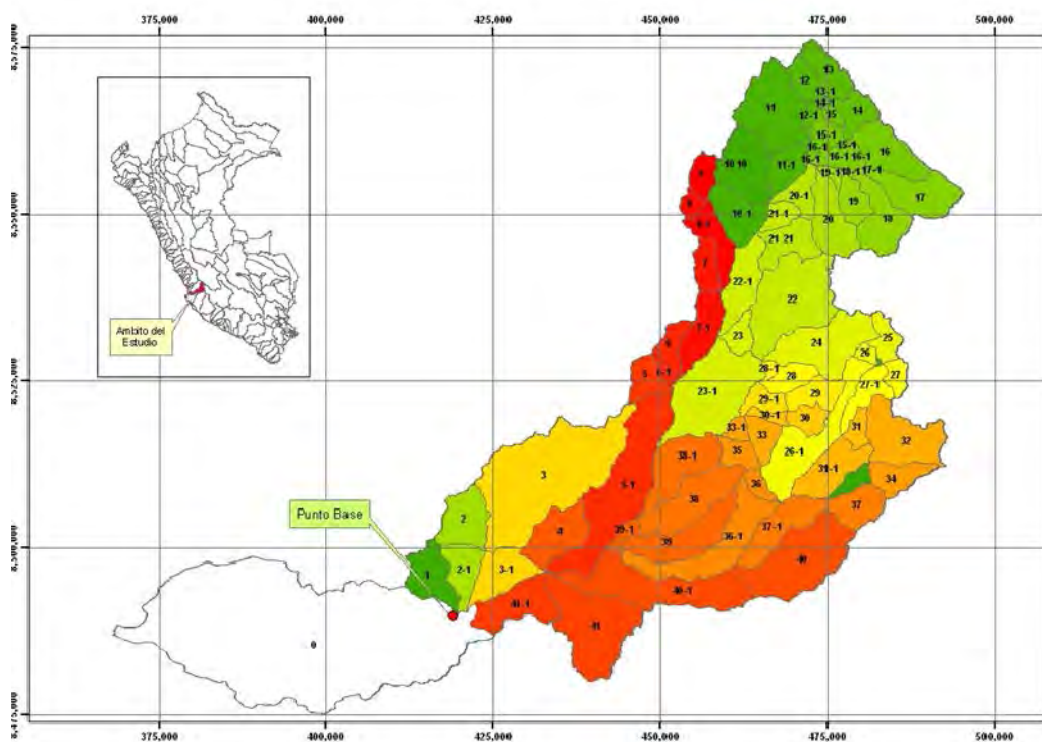
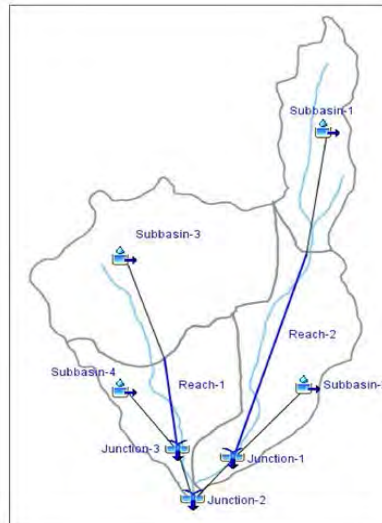

Figure-3.1.9.4-1 Division of Pisco basin

## 2) Preparation of basin model

The sub-basin, reach and junction are represented schematically as shown in the Figure-3.1.9.4-2 in HEC-HMS.



**Figure-3.1.9.4-2 Schematic diagrams in HEC-HMS**

## (3) Rainfall analysis

Information was collected on hourly rainfall of Chivay station located in the middle basin for the period February 2011 to February 2012. Using this information, a Depth-Duration Analysis was performed for 3 different periods of flood. Of the 3 cases of floods, the longest storm duration was measured in the period of February 2012 ( $Q_p = 1.400 \text{ m}^3/\text{sec.}$ ) and the duration was 17 hours. Thus in the discharge analysis the used storm duration was 24 hours. Furthermore, according to interviews with representatives of SENAMHI and Peruvian universities, on the Peruvian coast storm duration range is from 6 to 12 hours and for calculations for discharge analysis the usually used storm duration is 24 hours.

### 1) Probable 24-hourly rainfall

The probable 24-hour rainfall in each observation station is calculated by statistical processing of yearly maximum rainfall of 24-hour as shown in the Table-3.1.9.4-1. Based on the table the isohyetal map of 24h-hour rainfall with return period of 50-year is as shown in the Figure-3.1.9.4-3.

**Table-3.1.9.4-1 Probable 24-hour rainfall in each station (Pisco basin)**

Station	Return Period (year)						
	PT_2	PT_5	PT_10	PT_25	PT_50	PT_100	PT_200
ACNOCOCHA	27.0	30.0	32.0	34.0	35.0	36.0	37.0
CHOCLOCOCHA	30.0	43.0	51.0	60.0	66.0	71.0	76.0
COCAS	22.0	30.0	34.0	38.0	40.0	42.0	43.0
CUSICANCHA	19.0	26.0	29.0	33.0	35.0	37.0	39.0
HACIENDA BERNALES	0.0	1.0	3.0	6.0	11.0	19.0	34.0
HUAMANI	2.0	7.0	13.0	25.0	39.0	61.0	93.0
PARIONA	33.0	40.0	43.0	46.0	48.0	49.0	50.0
SAN JUAN DE CASTROVIRREYNA	17.0	23.0	29.0	36.0	42.0	49.0	56.0
TAMBO	26.0	35.0	40.0	46.0	49.0	52.0	55.0
TICRAPO	20.0	31.0	37.0	45.0	50.0	55.0	60.0
TOTORA	24.0	29.0	32.0	36.0	38.0	40.0	42.0
TUNEL CERO	29.0	36.0	41.0	48.0	54.0	61.0	67.0

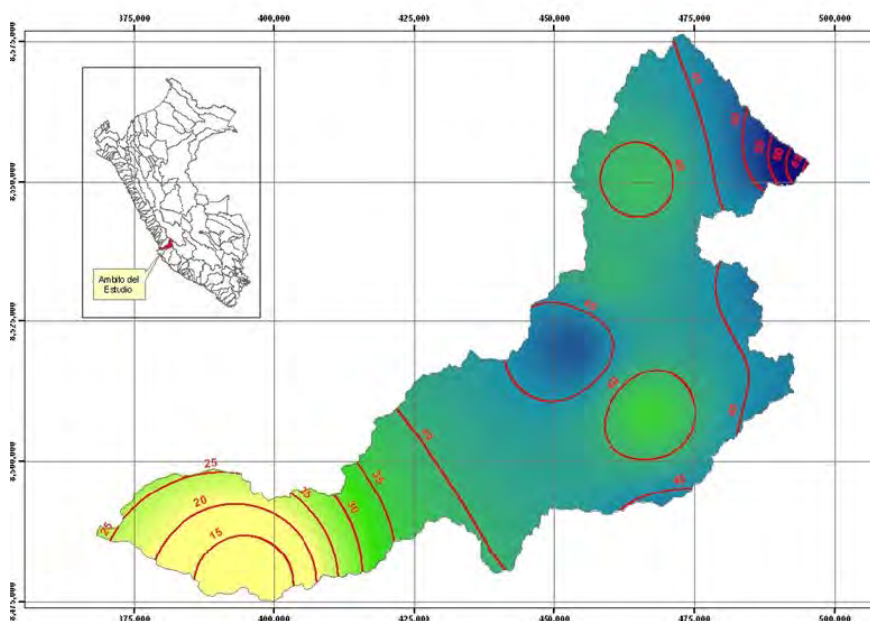

**Figure-3.1.9.4-3 Isohyetal map of 24-hour rainfall with return period of 50-year (Pisco basin)**

2) 24-hour rainfall in sub-basin

24-hour rainfall in sub-basin is calculated based on 24-hour rainfall of observation stations by Inverse Distance Weighted method as shown in the Table-3.1.9.4-2. The table is for some sub-basin among many sub-basins in Pisco basin. It is usually required to determine for each sub-basin the probabilistic rainfall using the maximum values of precipitation for each year calculated from the average precipitation. However, since the rainfall information is incomplete, it is difficult to

calculate average rainfall, this is the reason why there was no choice but to use probabilistic rainfall average of each sub-basin calculated from probabilistic rainfall information from each of the rainfall stations. The results of this calculation are presented in the Table -3.1.9.4-2.

Inverse Distance Weighted method is included in HEC-HMS for calculation of average rainfall over basin, and which is calculated by the following equation using the observation data surrounding the objective sub-basin (refer to HEC-HMS, Technical Reference Manual, p-23).

$$wc = (1/dc^2)/(1/da^2) + (1/db^2) + (1/dc^2)$$

$$P = waPa + wbPb + wcPc$$

where;  $wc$  : weight of station  $c$ ,  $d$ : distance from the center of sub-basin to each station  $P$  : average rainfall in sub-basin,  $Pa, b, c$ : rainfall in each station

**Table-3.1.9.4-2 Probable 24-hour rainfall in sub-basin (Pisco basin)**

SUBCUENCA	AREA [m <sup>2</sup> ]	PERIODO DE RETORNO T [AÑOS]					
		PT_2	PT_5	PT_10	PT_25	PT_50	PT_100
0	774,360,000	5.4	8.3	11.2	15.6	21.2	29.5
1	48,731,800	12.5	17.9	22.0	28.1	34.0	42.3
10	69,819,600	23.8	29.7	33.2	37.7	40.2	42.9
10-1	48,920,900	23.8	29.3	32.6	36.8	39.1	41.4
11	95,251,900	24.1	30.7	34.8	39.8	43.0	46.3
11-1	32,178,400	24.2	30.1	33.6	38.2	40.8	43.4
12	24,316,700	24.5	31.6	35.9	41.2	44.7	48.2
12-1	7,599,270	24.6	31.4	35.6	40.8	44.1	47.4
13	34,377,100	24.8	32.1	36.6	42.1	45.7	49.3
13-1	528,564	24.8	32.0	36.4	41.7	45.2	48.7
14	28,835,500	25.5	33.0	37.6	43.2	46.9	50.5
14-1	736,281	24.9	32.0	36.4	41.7	45.2	48.7
15	6,629,310	25.0	32.2	36.5	41.9	45.3	48.8
15-1	23,888,300	24.9	31.7	36.0	41.1	44.4	47.7
16	58,145,800	26.7	35.1	40.3	46.5	50.5	54.4
16-1	22,568,800	25.2	32.3	36.6	41.8	45.1	48.5
17	62,232,400	28.1	37.9	44.0	51.0	55.7	59.9
17-1	969,962	25.8	33.2	37.8	43.2	46.8	50.3
18	56,833,600	26.7	33.8	38.3	43.7	47.3	50.8
18-1	1,282,460	25.4	32.5	36.8	42.0	45.4	48.7
19	26,733,300	25.7	32.6	36.9	42.1	45.4	48.8
19-1	6,671,040	24.9	31.6	35.6	40.6	43.7	46.8
2	52,919,500	16.1	22.5	27.0	33.2	38.6	45.6
20	56,155,800	25.0	31.3	35.2	40.0	43.0	46.1
20-1	26,253,900	24.2	30.0	33.5	37.9	40.4	43.0
21	43,743,800	24.0	29.9	33.3	37.7	40.1	42.7
2-1	38,110,400	14.0	19.9	24.3	30.7	36.6	44.8
21-1	17,536,300	24.0	29.2	32.3	36.5	38.6	40.7
22	133,682,000	23.5	30.6	34.6	39.3	42.1	45.0
22-1	54,257,600	22.8	29.9	33.7	38.0	40.4	42.8
23	19,208,200	22.0	30.0	34.1	38.3	40.5	42.7
23-1	133,886,000	20.9	30.3	35.4	41.8	45.7	49.6
24	92,053,600	24.5	31.5	35.6	40.6	43.9	47.3
25	21,774,100	27.0	33.4	37.4	42.7	46.6	51.0

### 3) Selection of type of 24-hour rainfall curve

There is not hourly rainfall observation data but 24-hour rainfall observation data (daily rainfall data) so that the hourly data cannot but being estimated by 24-hour rainfall data.

SCS (Soil Conservation Service) hypothetical storm which is generally used in HEC-HMS is used for 24-hour rainfall curve.

This method is developed through the analysis of rainfall data in USA, which is expressed 4 types of rainfall curve with non-dimension as shown in the Table-3.1.9.4-3 and the Figure-3.1.9.4-4. The distribution of rainfall is as shown in the Figure-3.1.9.4-5 assuming time interval. And the applied

area of 4 types in USA is as shown in the Figure-3.1.9.4-6, according to which the type II is recommended to be applied to major part of USA. In addition to this it is said that 24-hour rainfall can be applicable for most of basins.

Since there is no hourly rainfall data in the study area, it is difficult to judge the type of rainfall, however the type is determined actually based on a few study examples in Peru. Miplo Mining Company analyzed the hourly rainfall data which was obtained from Chavin station installed western slope of Peru (between Cañete basin and highland of Chinchá basin), and judged the rainfall type of this area belongs to type II, and that the type II can be also applied the central and south of coastal area. Based on these study results, type II is applied for Pisco basin.

**Table-3.1.9.4-3 Accumulated curve of 24-hour rainfall in SCS hypothetical storm**

Time (hr)	t/24	24 hr precipitation temporal distribution			
		Type I	Type IA	Type II	Type III
0.00	0.000	0.000	0.000	0.000	0.000
2.00	0.083	0.035	0.050	0.022	0.020
4.00	0.167	0.076	0.116	0.048	0.043
6.00	0.250	0.125	0.206	0.080	0.072
7.00	0.292	0.156	0.268	0.098	0.089
8.00	0.333	0.194	0.425	0.120	0.115
8.50	0.354	0.219	0.480	0.133	0.130
9.00	0.375	0.254	0.520	0.147	0.148
9.50	0.396	0.303	0.550	0.163	0.167
9.75	0.406	0.362	0.564	0.172	0.178
10.00	0.417	0.515	0.577	0.181	0.189
10.50	0.438	0.583	0.601	0.204	0.216
11.00	0.458	0.624	0.624	0.235	0.250
11.50	0.479	0.654	0.645	0.283	0.298
11.75	0.490	0.669	0.655	0.357	0.339
12.00	0.500	0.682	0.664	0.663	0.500
12.50	0.521	0.706	0.683	0.735	0.702
13.00	0.542	0.727	0.701	0.772	0.751
13.50	0.563	0.748	0.719	0.799	0.785
14.00	0.583	0.767	0.736	0.820	0.811
16.00	0.667	0.830	0.800	0.880	0.886
20.00	0.833	0.926	0.906	0.952	0.957
24.00	1.000	1.000	1.000	1.000	1.000

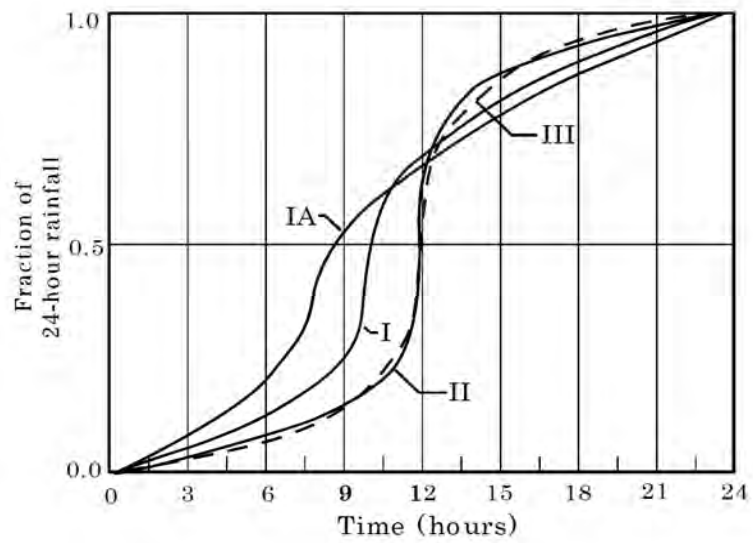

Source :Urban water hydrology for small watersheds(TR-55) Appendix B

**Figure-3.1.9.4-4 Distribution of 24hour rainfall in each type**

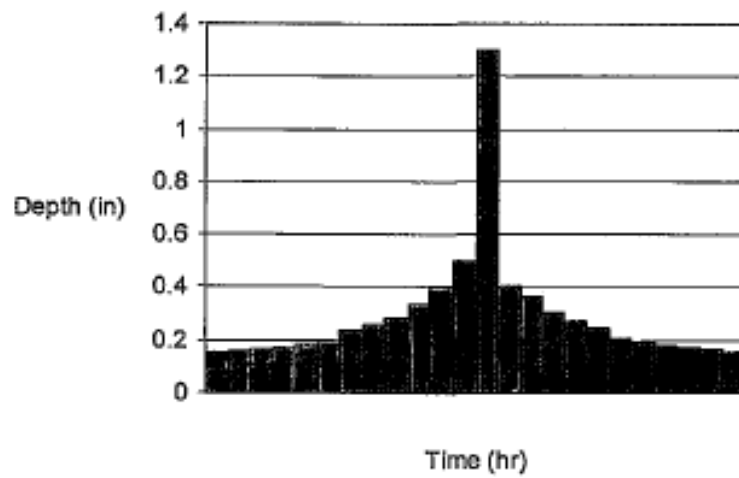

**Figure-3.1.9.4-5 Division of 24-hour rainfall**

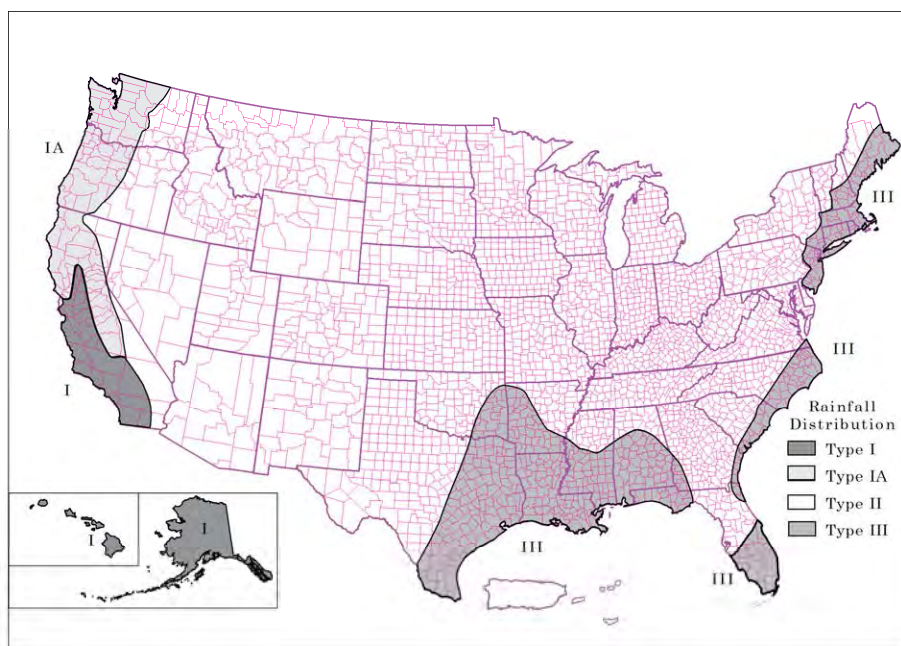

Source :Urban water hydrology for small watersheds(TR-55) Appendix B

**Figure-3.1.9.4-6 Type of 24-hour Rainfall and Applied Area**

**(4) Excess rainfall by SSC method**

1) Basic Formula

SSC Curve Number (CN) Loss Model is to estimate the excess rainfall based on the function of accumulated rainfall, soil conditions, land use, initial rainfall loss etc. in the following formula.

$$P_e = \frac{(P - I_a)^2}{P - I_a + S}$$

where;  $P_e$  :Excess rainfall at time t ;  $P$  : Accumulated rainfall at time t ;  $I_a$  :Initial loss ;  $S$  : Possible storage volume

Assuming  $I_a = 0.2 S$

$$P_e = \frac{(P_e - 0.2S)^2}{P + 0.8S}$$

Relation  $S$  and  $CN$  representing basin characteristics is as shown below.

$$S = \frac{1000}{CN} - 10$$

Assuming  $CN$ , the relation  $P_e$  and  $P$  is calculated as shown the Figure-3.1.9.4-7.

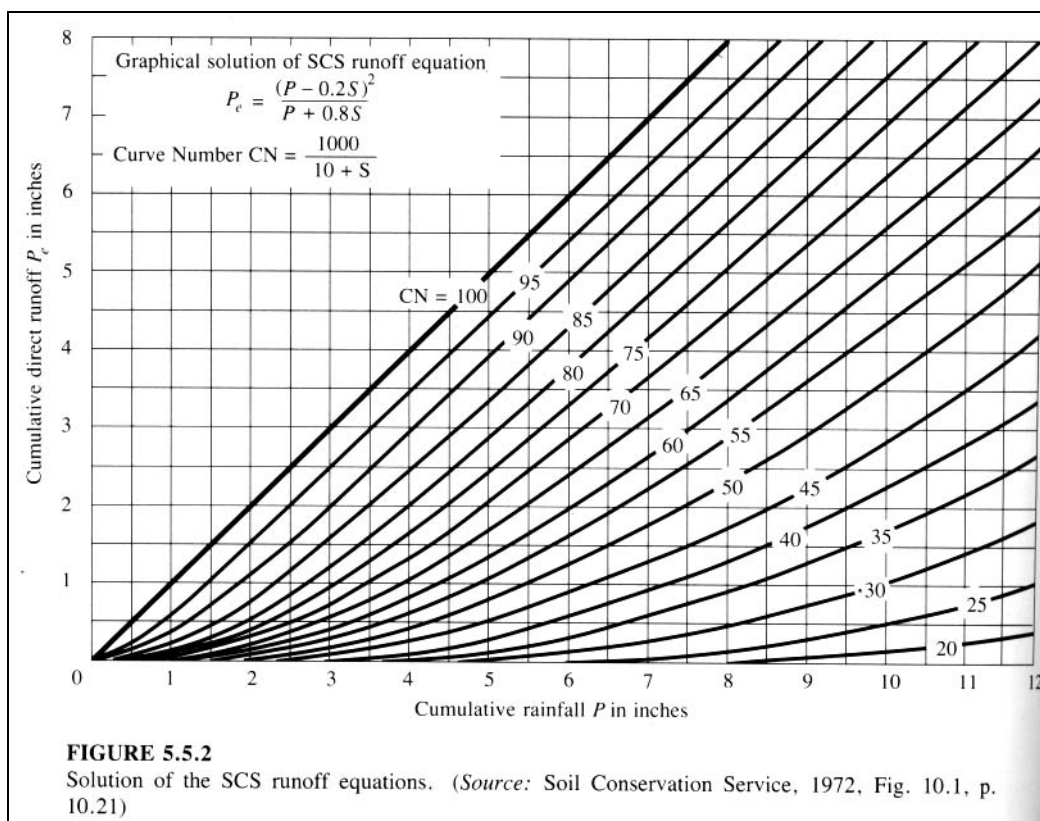

**Figure-3.1.9.4-7 Relation among CN, P and  $P_e$**

2) Selection of CN in sub-basin

Referring to the Table-3.1.9.4-4 and based on the land use and soil conditions, CN of each sub-division is determined.

The initial CN value in Pisco basin is determined from 75 to 78 considering the basin characteristics and the past experiences and so on.

The run-off analysis carried out based on the initial value of CN, and the each probable flood peak and flood hydrograph are calculated for various values of CN. And examining the calculation results, the final CN value is determined as 84.

Since there is no hourly discharge data but only daily data, it is difficult to verify the study results strictly; however the verification is carried out as shown in the clause 3.1.9.5.



**Table-3.1.9.4-4(1) CN Value depending on land use and soil conditions (1/3)**

Land Use Description		Hydrologic Soil Group			
		A	B	C	D
Cultivated land <sup>1</sup> : without conservation treatment		72	81	88	91
with conservation treatment		62	71	78	81
Pasture or range land: poor condition		68	79	86	89
good condition		39	61	74	80
Meadow: good condition		30	58	71	78
Wood or forest land: thin stand, poor cover, no mulch		45	66	77	83
good cover <sup>2</sup>		25	55	70	77
Open Spaces, lawns, parks, golf courses, cemeteries, etc.					
good condition: grass cover on 75% or more of the area		39	61	74	80
fair condition: grass cover on 50% to 75% of the area		49	69	79	84
Commercial and business areas (85% impervious)		89	92	94	95
Industrial districts (72% impervious)		81	88	91	93
Residential <sup>3</sup> :					
Average lot size	Average % impervious <sup>4</sup>				
1/8 acre or less	65	77	85	90	92
1/4 acre	38	61	75	83	87
1/3 acre	30	57	72	81	86
1/2 acre	25	54	70	80	85
1 acre	20	51	68	79	84
Paved parking lots, roofs, driveways, etc. <sup>5</sup>		98	98	98	98
Streets and roads:					
paved with curbs and storm sewers <sup>5</sup>		98	98	98	98
gravel		76	85	89	91
dirt		72	82	87	89

<sup>1</sup>For a more detailed description of agricultural land use curve numbers, refer to Soil Conservation Service, 1972, Chap. 9

<sup>2</sup>Good cover is protected from grazing and litter and brush cover soil.

<sup>3</sup>Curve numbers are computed assuming the runoff from the house and driveway is directed towards the street with a minimum of roof water directed to lawns where additional infiltration could occur.

<sup>4</sup>The remaining pervious areas (lawn) are considered to be in good pasture condition for these curve numbers.

<sup>5</sup>In some warmer climates of the country a curve number of 95 may be used.

**Table3.1.9.4-4(2) CN value depending on land use and soil conditions (2/3)**

<b>TABLE 5.5.1 SCS Runoff Curve Numbers (Continued)</b>					
<i>c. Other agricultural areas</i>					
Cover description		Curve numbers for hydrologic soil group			
Cover type	Hydrologic condition	A	B	C	D
Pasture, grassland, or range—continuous forage for grazing*	Poor	68	79	86	89
	Fair	49	69	79	84
	Good	39	61	74	80
Meadow—continuous grass, protected from grazing and generally mowed for hay	—	30	58	71	78
Brush—brush-weed-grass mixture with brush the major element†	Poor	48	67	77	83
	Fair	35	56	70	77
	Good	30	48	65	73
Woods-grass combination (orchard or tree farm)‡	Poor	57	73	82	86
	Fair	43	65	76	82
	Good	32	58	72	79
Woods§	Poor	45	66	77	83
	Fair	36	60	73	79
	Good	30	55	70	77
Farmsteads—buildings, lanes, driveways, and surrounding lots	—	59	74	82	86

\* *Poor*: < 50% ground cover or heavily grazed with no mulch.  
*Fair*: 50 to 75% ground cover and not heavily grazed.  
*Good*: > 75% ground cover and lightly or only occasionally grazed.  
† *Poor*: < 50% ground cover.  
*Fair*: 50 to 75% ground cover.  
*Good*: > 75% ground cover.  
‡ CNs shown were computed for areas with 50% woods and 50% grass (pasture) cover. Other combinations of conditions may be computed from the CNs for woods and pasture.  
§ *Poor*: Forest litter, small trees, and brush are destroyed by heavy grazing or regular burning.  
*Fair*: Woods are grazed but not burned, and some forest litter covers the soil.  
*Good*: Woods are protected from grazing, and litter and brush adequately cover the soil.  
**Source**: Ref. 105.

<i>d. Arid and semiarid range areas</i>					
Cover description		Curve numbers for hydrologic soil group			
Cover type	Hydrologic condition*	A†	B	C	D
Herbaceous—mixture of grass, weeds, and low-growing brush, with brush the minor element	Poor	80	87	93	
	Fair	71	81	89	
	Good	62	74	85	
Oak-aspen—mountain brush mixture of oak brush, aspen, mountain mahogany, bitter brush, maple, and other brush	Poor	66	74	79	
	Fair	48	57	63	
	Good	30	41	48	
Piñon-juniper—piñon, juniper, or both: grass understory	Poor	75	85	89	
	Fair	58	73	80	
	Good	41	61	71	
Sagebrush with grass understory	Poor	67	80	85	
	Fair	51	63	70	
	Good	35	47	55	

**Table-3.1.9.4-4(3) CN value depending on land use and soil conditions (3/3)**

TABLE 5.5.1 SCS Runoff Curve Numbers (Continued)					
d. Arid and semiarid range areas					
Cover description		Curve numbers for hydrologic soil group			
Cover type	Hydrologic condition*	A <sup>†</sup>	B	C	D
Desert shrub—major plants include saltbush, greasewood, creosotebush, blackbrush, bursage, palo verde, mesquite, and cactus	Poor	63	77	85	88
	Fair	55	72	81	86
	Good	49	68	79	84

\* *Poor*: <30% ground cover (litter, grass, and brush overstory).  
*Fair*: 30 to 70% ground cover.  
*Good*: >70% ground cover.  
<sup>†</sup> Curve numbers for group A have been developed only for desert shrub.  
*Source*: Ref. 105.

Source: Maidment (1993).

**Note: Hydrological Soil Group**

**Group A**soils have low runoff potential and high infiltration rates even when thoroughly wetted. They consist chiefly of deep, well to excessively drained sand or gravel and have a high rate of water transmission (greater than 0.30 in/hr).

**Group B**soils have moderate infiltration rates when thoroughly wetted and consist chiefly of moderately deep to deep, moderately well to well drained soils with moderately fine to moderately coarse textures. These soils have a moderate rate of water transmission (0.15-0.30 in/hr).

**Group C**soils have low infiltration rates when thoroughly wetted and consist chiefly of soils with a layer that impedes downward movement of water and soils with moderately fine to fine texture. These soils have a low rate of water transmission (0.05-0.15 in/hr).

**Group D**soils have high runoff potential. They have very low infiltration rates when thoroughly wetted and consist chiefly of clay soils with a high swelling potential, soils with a permanent high water table, soils with a claypan or clay layer at or near the surface, and shallow soils over nearly impervious material. These soils have a very low rate of water transmission (0-0.05 in/hr).

**(5) Probable flood discharge and hydrograph**

The probable flood discharge and hydrograph are calculated by HEC-HM. The beginning of rainfall and flood hydrograph is assumed to be same hour. The kinematic wave method is applied for the flood routing of river channel.

The calculation results are as shown in the Table-3.1.9.4-5~3.1.9.4-7 and the Figure-3.1.9.4 -8, and which are to be used for discharge capacity analysis of river channel, inundation analysis and flood

protection planning.

**Table-3.1.9.4-5 Probable flood discharge**

River/Reference Point	ReturnPeriod of 2-year	ReturnPeriod of 5-year	ReturnPeriod of 10-year	ReturnPeriod of 25-year	ReturnPeriod of 50-year	ReturnPeriod of 100-year
Pisco/ Letrayoc	213	287	451	688	855	962

(m<sup>3</sup>/s)

**Table-3.1.9.4-6 Probable specific flood discharge**

River/Reference Point	ReturnPeriod of 2-year	ReturnPeriod of 5-year	ReturnPeriod of 10-year	ReturnPeriod of 25-year	ReturnPeriod of 50-year	ReturnPeriod of 2-year	BasinArea Km2
Pisco/ Letrayoc	0.069	0.093	0.147	0.224	0.279	0.313	3,070

(m<sup>3</sup>/s/km<sup>2</sup>)

**Table-3.1.9.4-7 Past Maximum discharge and discharge with 50-year probability**

Basin/Base point	Historical Maximum Discharge	Measurement Period	Calculated Peak Discharge (t=1/50)
Pisco Letrayoc	957	76	855

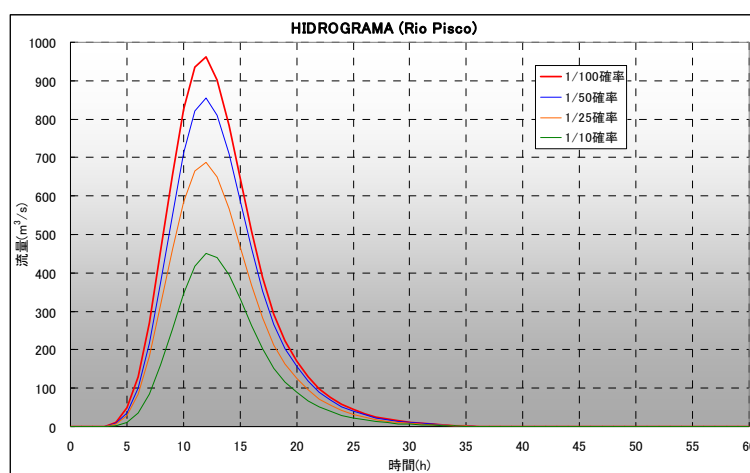

**Figure-3.1.9.4-8 Flood hydrograph in Pisco basin**

### 3.1.9.5 Consideration on Results of Analysis

In Figure-3.1.9.5-1 to 3.1.9.5-4 is plotted the specific probabilistic return flow and the results of discharges analyzes conducted for each river in coastal area of Peru. (Source: "Estudio Hidrológico - Meteorológico en la Vertiente del Pacífico del Perú con Fines de Evaluación y Pronóstico del Fenómeno El Niño para Prevención y Mitigación de Desastres", Ministerio de Economía y Finanzas,

Asociación BCEOM - Sofi Consult S.A. ORSTOM, Nov. 1999.)

Comparing the Creager envelopes curves and the calculated specific flows for each of the basins we can conclude that calculated probabilistic discharges are within the acceptable range.

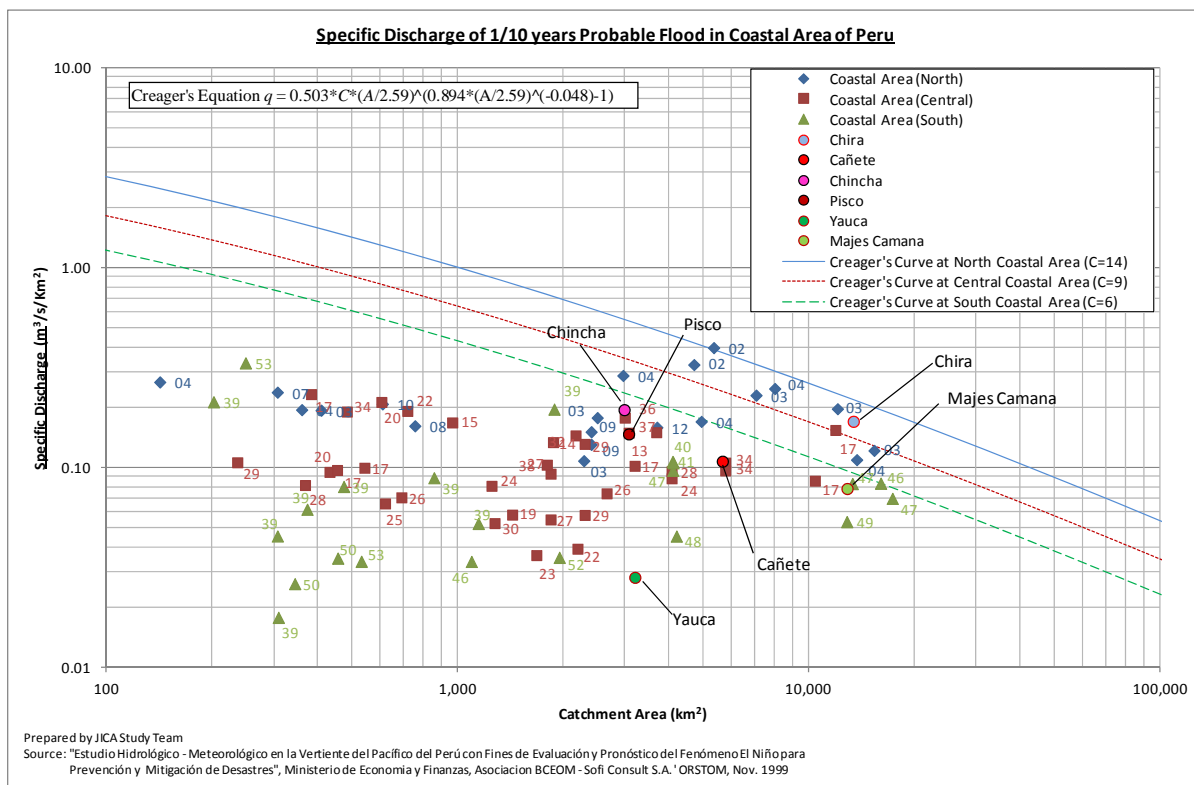

Figure 3.1.9.5-1 Probabilistic specific discharges and calculated peak discharges (t=1/10)

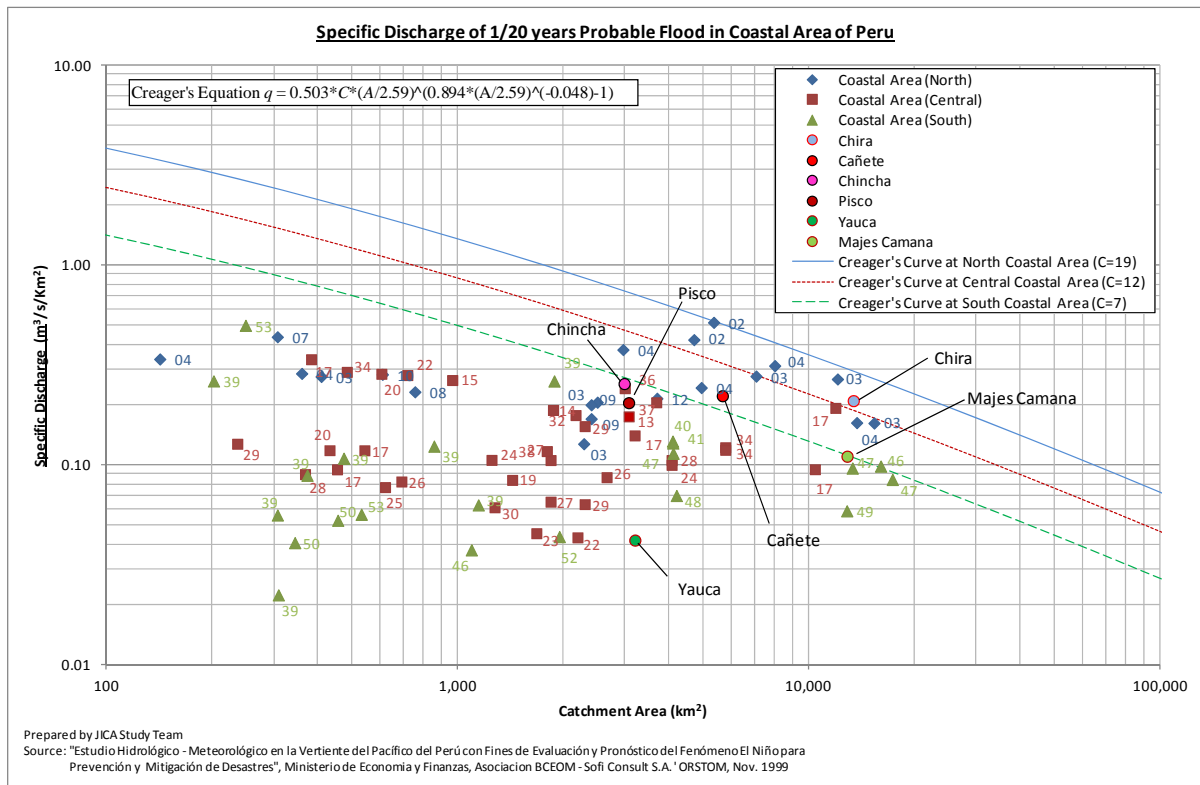

Figure 3.1.9.5-2 Probabilistic specific discharges and calculated peak discharges (t=1/20)

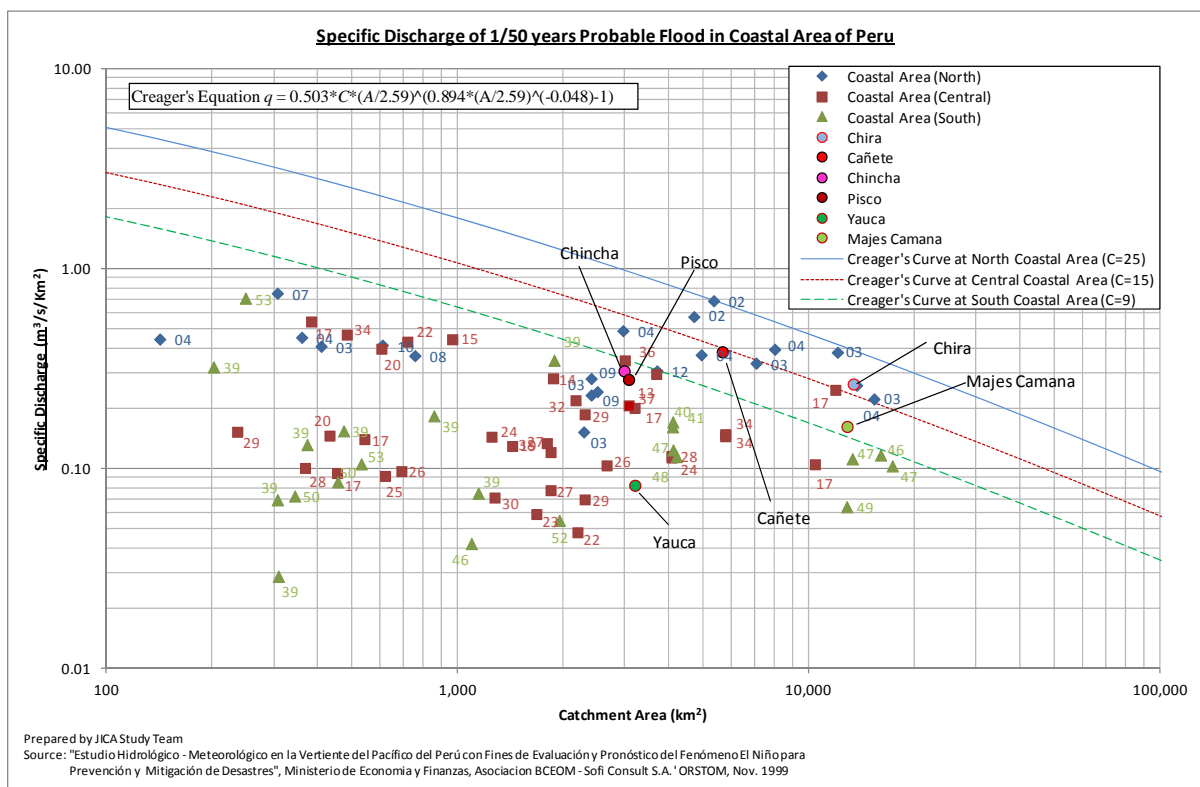

Figure 3.1.9.5-3 Probabilistic specific discharges and calculated peak discharges (t=1/50)

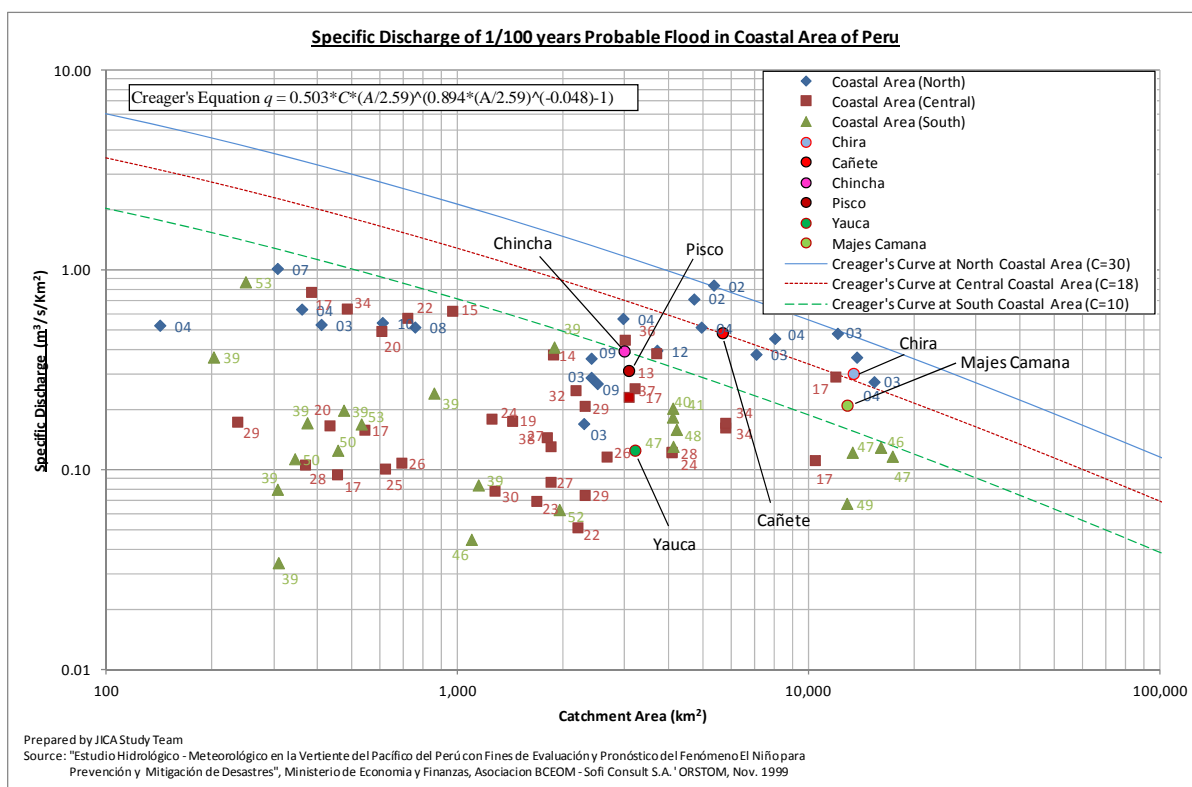

Figure 3.1.9.5-4 Probabilistic specific discharges and calculated peak discharges (t=1/100)

### 3.1.10 Analysis of Inundation

#### (1) River surveys

Prior to the flood analysis, the transversal survey of Pisco river was performed as well as the longitudinal survey of dikes. Table 3.1.10-1 shows the results of the surveys in the river of this Study.

In order to obtain the topographic data for the analysis of the flooding zones, the results of the true measurement results indicated in Table 3.1.10-1 were used as a complement, using the satellite figures data.

**Table 3.1.10-1 Basic data of the river surveys**

Lifting	Unit	Quantity	Notes
1. Control spots lifting			
Pisco River	No.	5	
2. Dike's transversal lifting			Interval of 250 m, only one margin
Pisco River	km	45	
3. River's transversal lifting			Interval 500 m
Pisco River	km	54.6	91 lines 1x0.6 km
4. Landmarks			
Type A	No.	5	Each one of the control spots
Type B	No.	45	45km x one spot/ km
Subtotal		50	

## (2) Inundation analysis methods

Since the DGIH carried out the inundation analysis of the profile study at a program level using the HEC-RAS model, for this Study, we decided to used this method, and review and modify it, if necessary.

### 1) Analysis basis

Normally, for the inundation analysis the following three methods are used.

- ① Varied flow one-dimensional model
- ② Tank model
- ③ Varied flow horizontal two dimensional model

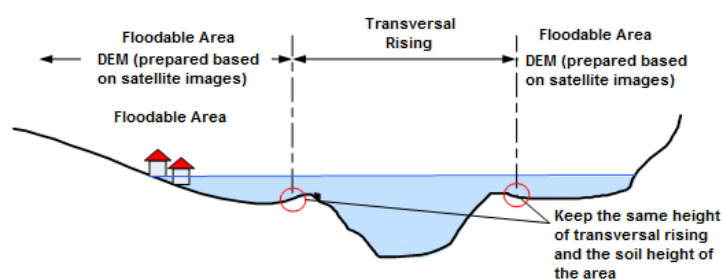

**Figure 3.1.10-1 Idea of one dimensional model**

The time and cost required by each method vary considerably, so only the most efficient method will be chosen, which guarantees the necessary accurateness degree for the preparation of the floodable zone maps.

Table 3.1.10-2 shows the characteristics of each analysis method. From the results of the simulation performed by DGIH, it is known that the rivers have a slope between 1/100 and 1/300, so initially



the varied flow one-dimensional model was chosen assuming that the floods were serious. However, we considered the possibility that the overflowed water extends within the watershed in the lower watershed, so for this study the variable regimen horizontal bi-dimensional model was used to obtain more accurate results

**Table 3.1.10-2 Methodology of inundation analysis**

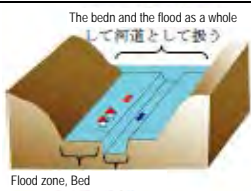
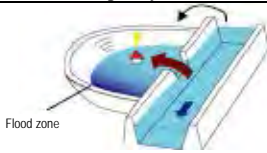
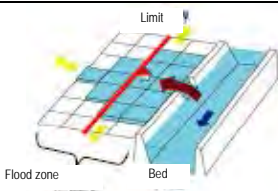
Analysis methods	Vary flow unidimensional model	Tank model	Varied flow bi-dimensional horizontal model
Basic concept of the flood zone definition	In this method, the flood zone is considered to be included in the river bed, and the flood zone is determined by calculating the water level of the bed in relation to the maximum flooding flow	This method manages the flood zone and bed separately, and considers the flooding zone as a closed body. This closed water body is called <i>pond</i> where the water level is uniform. The flood zone is determined in relation to the relationship between the overflowed water from the river and entered to the flood zone, and the topographic characteristics of such zone (water level– capacity– surface).	This method manages the flood zones and the bed separately, and the flood zone is determined by analyzing the bidimensional flow of the behaviour of water entered to the flood zone.
Approach			
Characteristics	It is applicable to the floods where the overflowed water runs by the flood zone by gravity; that means, current type floods. This method must manage the analysis area as a protected area (without dikes).	Applicable to blocked type floods where the overflowed water does not extend due to the presence of mountains, hills, embankments, etc. The water level within this closed body is uniform, without flow slope or speed. In case there are several embankments within the same flood zone, it may be necessary to apply the pond model in series distinguishing the internal region.	Basically, it is applicable to any kind of flood. Beside the flood maximum area and the water level, this method allows reproducing the flow speed and its temporary variation. It is considered as an accurate method compared with other methods, and as such, it is frequently applied in the preparation of flood irrigation maps. However, due to its nature, the analysis precision is subject to the size of the analysis model grids.

## 2) Inundation analysis method

Figure 3.1.10-2 shows the conceptual scheme of the variable regimen horizontal bi-dimensional model.

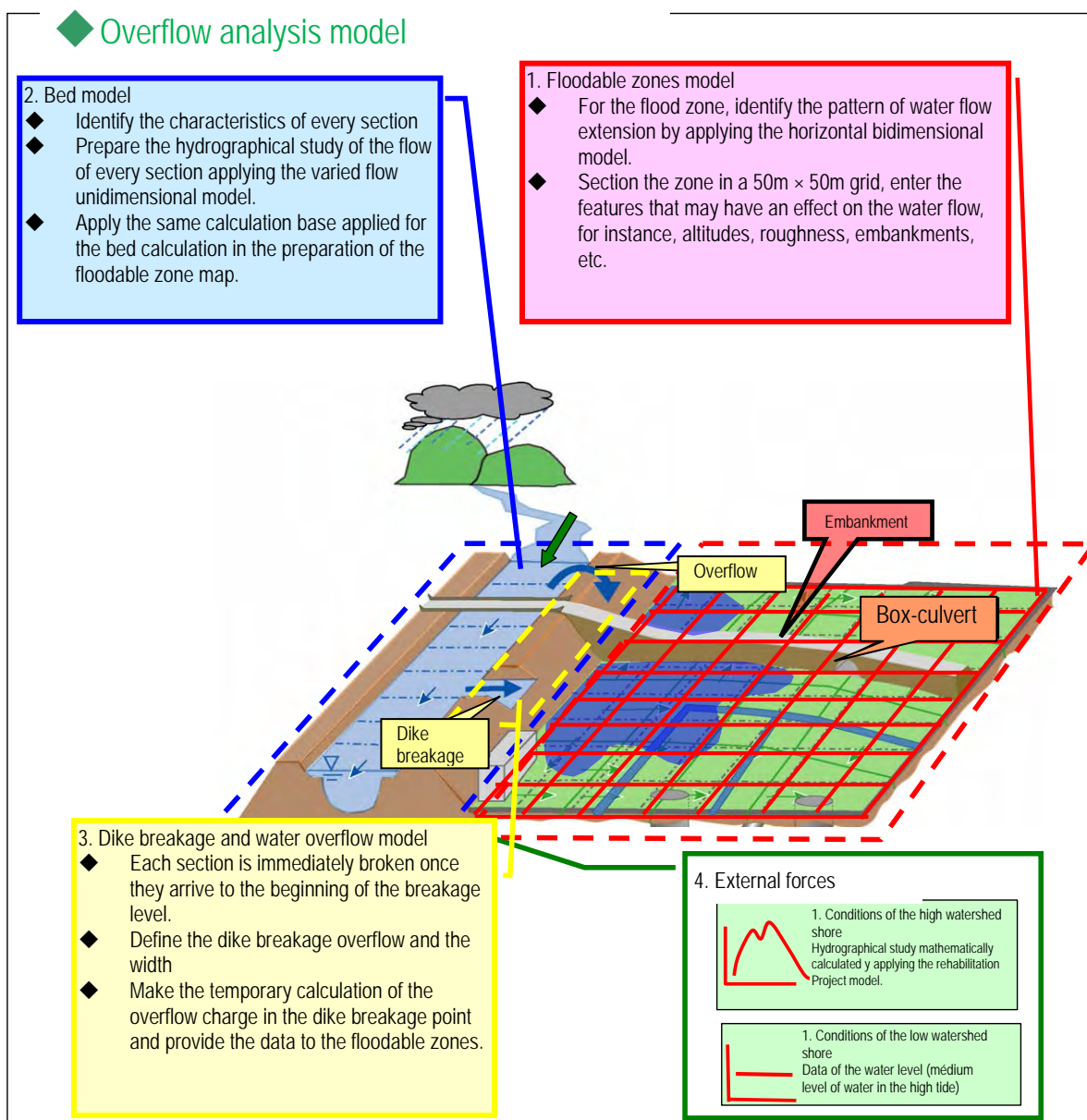

**Figure 3.1.10-2 Conceptual scheme of the inundation analysis model**

### (3) Discharge capacity analysis

The current discharge capacity of the river channel was estimated based on the results of the river survey and applying the HEC-RAS method, which results appear in Figure 3.1.10-3. This Figure also shows the flooding flows of different return periods, which allow evaluating in what points of the Chincha river watershed flood may happen and what magnitude of flood flow may they have.

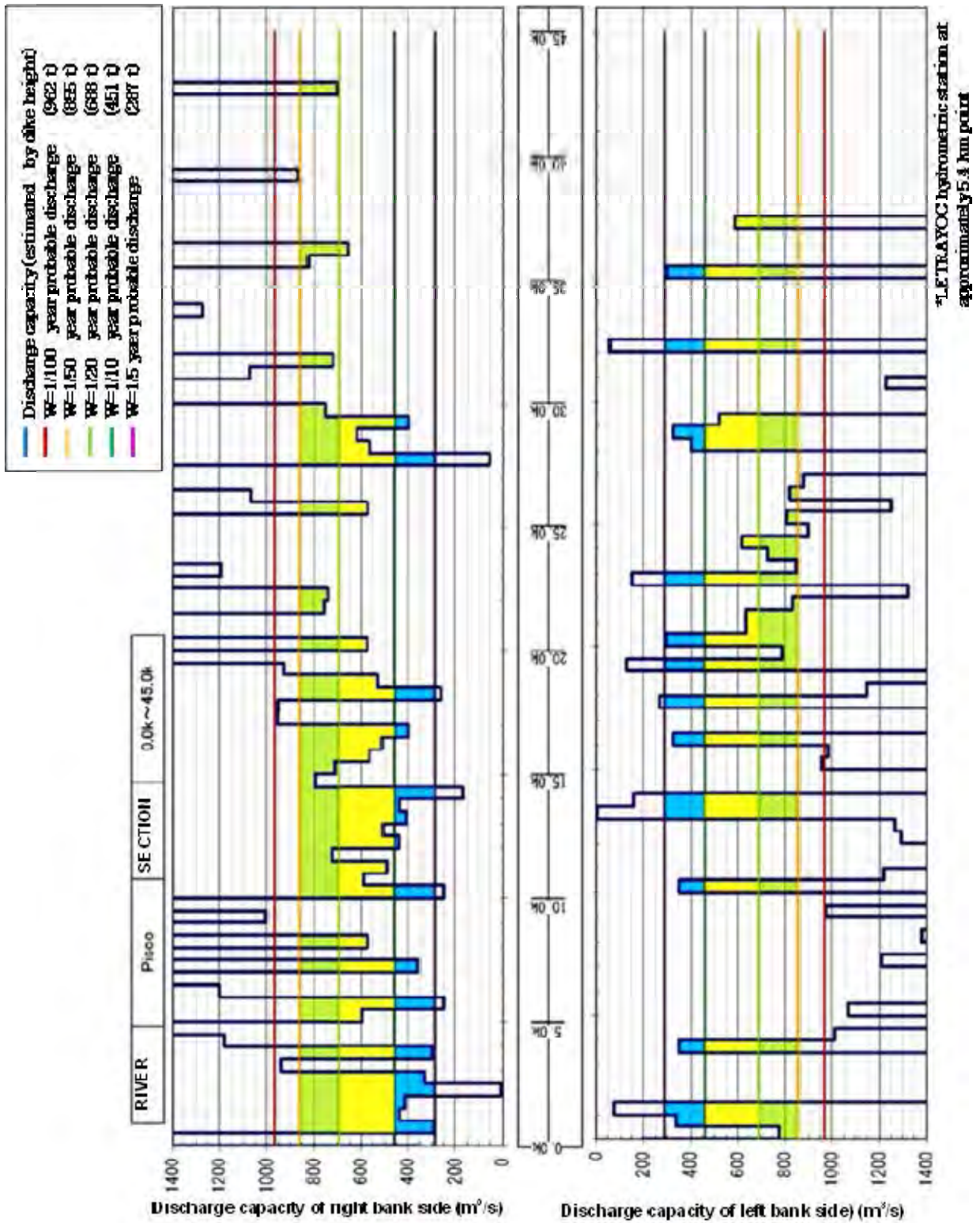
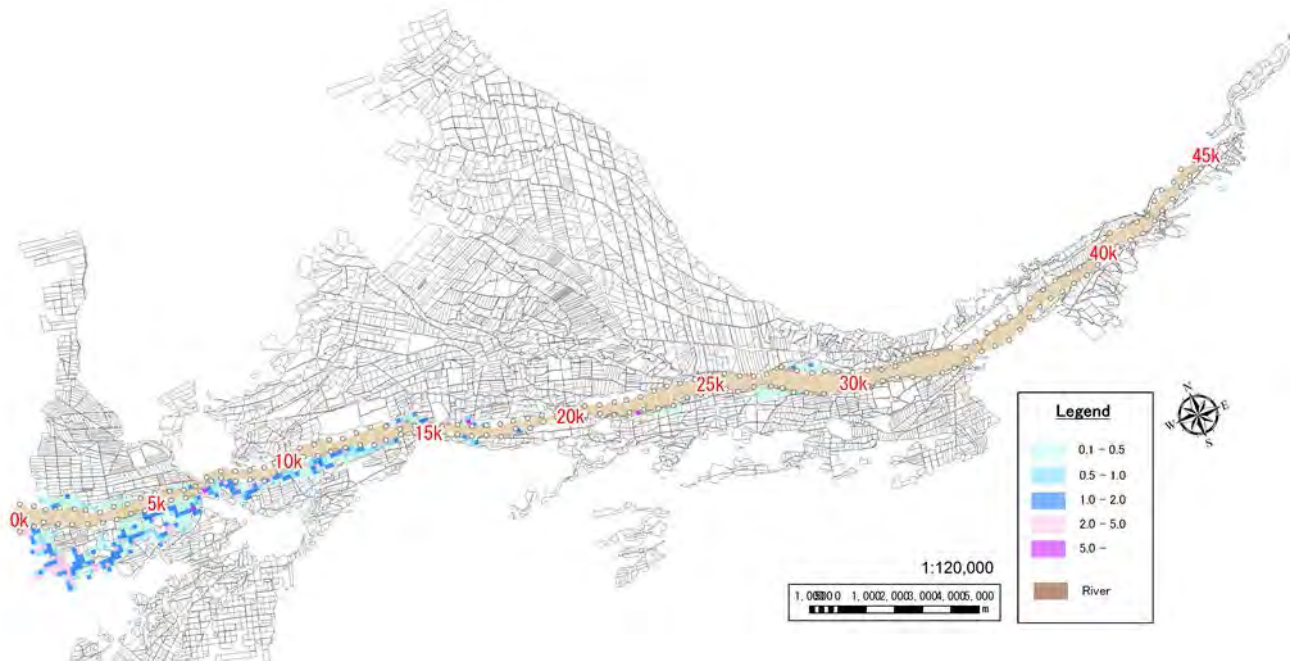

Figure 3.1.10-3 Current hydraulic capacity of Pisco river

#### (4) Inundation area

As a reference, Figures 3.1.10-4 show the results of the inundation area calculation in the Pisco river watershed compared to the flooding flow with a 50 year return period.



**Figure 3.1.10-4 Inundation area of Pisco river (50 year period floods)**

### 3.2 Definition of Problem and Causes

#### 3.2.1 Problems of Flood Control Measures in the Study Area

Based on the results of the Pisco River, the main problem on flood control was identified, as well as the structures to be protected, which results are summarized in Table 3.2.1-1.

**Table 3.2.1-1 Problems and conservation measures of flood control works**

Problems		Overflowing			Dike erosion	Margins erosion	Non-working intake	Non-working derivation works
		Without dikes	Sediment in bed	Lack of width				
Structures to be protected	Agricultural lands	○	○	○	○	○	○	○
	Irrigation channels					○	○	
	Urban area	○		○				○
	Roads					○		
	Bridges		○					

#### 3.2.2 Problem Causes

Next, the main problem and its direct and indirect causes for flood control in the Study Area are described:

##### (1) Main problem

Valleys and local communities highly vulnerable to floods

##### (2) Direct and indirect causes

Table 3.2.2-2 shows the direct and indirect causes of the main problem

**Table 3.2.2-2 direct and indirect causes of the main problem**

Direct cause	1. Excessive flood flow	2. Overflowing	3. Insufficient maintenance of control works	4. Insufficient communitarian activities for flood control
Indirect causes	1.1 Frequent occurrence of extraordinary weather (El Niño, etc..)	2. Lack of flood control works	3.1 Lack of maintenance knowledge and skills	4.1 Lack of knowledge and flood prevention techniques
	1.2 Extraordinary rains in the middle and upper basins	2.2 Lack of resources for the construction of works	3.2 Lack of training in maintenance	4.2 Lack of training in flood prevention
	1.3 Vegetation cover almost zero in the middle and upper basins	2.3 Lack of plans for flood control in basins	3.3 Lack of dikes and margins repair	4.3 Lack of early warning system
	1.4 Excessive sediment dragging from the upper and middle river levee	2.4 Lack of dikes	3.4 Lack of repair works and referral making	4.4 Lack of monitoring and collection of hydrological data
	1.5 Reduction of hydraulic capacity of	2.5 Lack of bed channel width	3.5 Use of illegal bed for agricultural	

rivers by altering slopes, etc.		purposes	
	2.6 Accumulation of sediments in beds	3.6 Lack of maintenance budget	
	2.7 Lack of width at the point of the bridge construction		
	2.8 Elevation of the bed at the point of the bridge construction		
	2.9 Erosion of dikes and margins		
	2.10 Lack of capacity for the design of the works		

### 3.2.3 Problem Effects

#### (1) Main problem

Valleys and local communities highly vulnerable to floods

#### (2) Direct and indirect effects

Table 3.2.3-1 shows the direct and indirect effects of the main problem

**Table 3.2.3-1 Direct and indirect effects of the main problem**

Direct Effects	1. Agriculture Damages	2. Direct damages to the community	3. Social infrastructure damages	4. Other economical damages
Indirect Effects	1.1 Agriculture and livestock damage	2.1 Private property and housing loss	3.1 Roads destruction	4.1 Traffic interruption
	1.2 Agricultural lands loss	2.2 Industries and facilities loss	3.2 Bridges loss	4.2 Flood and evacuations prevention costs
	1.3 Irrigation channels destruction	2.3 Human life loss and accidents	3.3 Running water, electricity, gas and communication infrastructures' damages	4.3 Reconstruction costs and emergency measures
	1.4 Work destruction and derivation	2.4 Commercial loss		4.4 Work loss by local inhabitants
	1.5 Dikes and margins erosion			4.5 Communities income reduction
				4.6 Life quality degradation
				4.7 Loss of economical dynamism

#### (2) Final effect

The main problem final effect is the community socio-economic impediment development of the affected area.

### 3.2.4 Causes and Effects Diagram

Figure 3.2.4-1 shows the causes and effects diagram done based on the above analysis results.

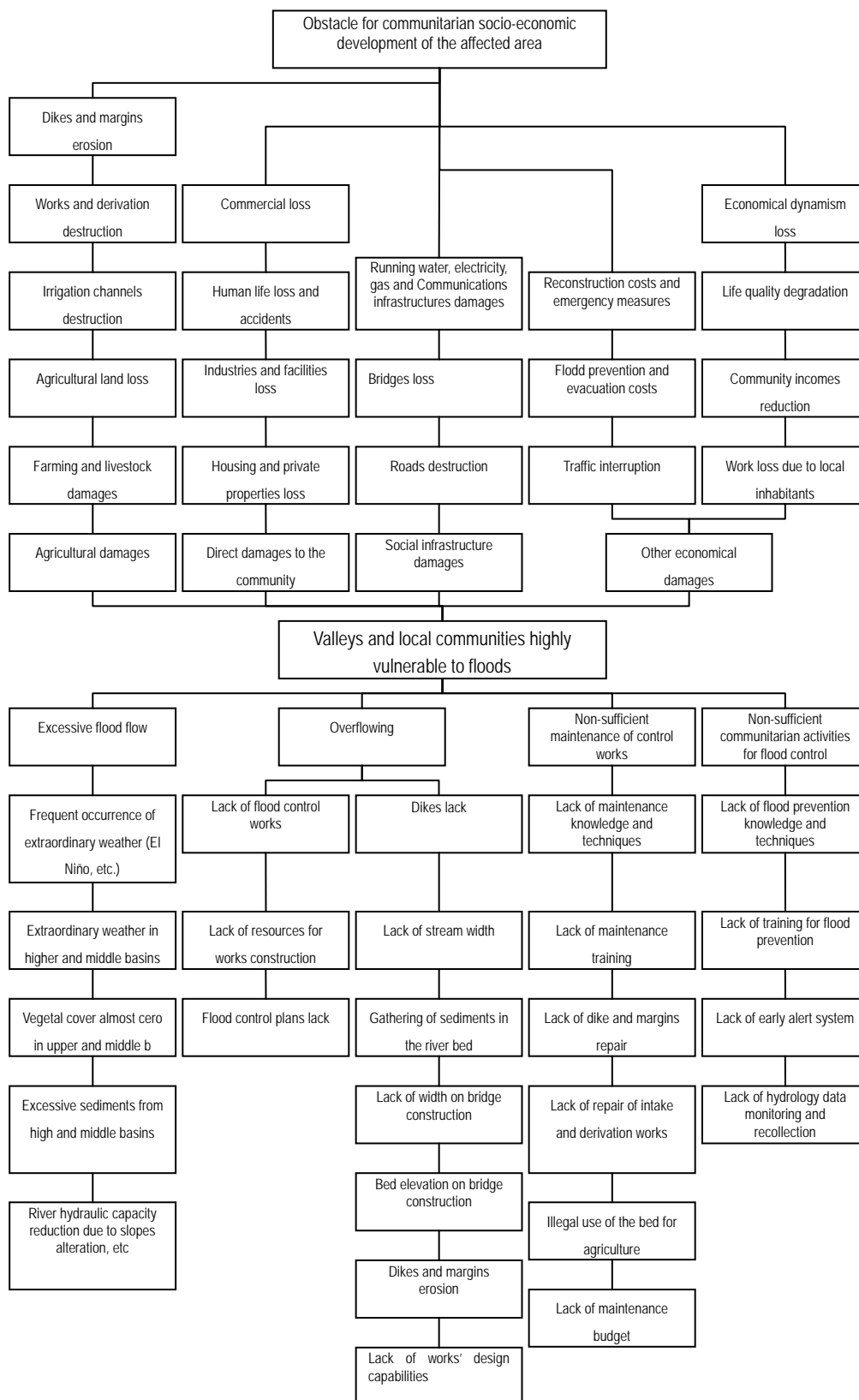

Figure 3.2.4-1 Causes and effects diagram

### 3.3 Objective of the Project

The final impact that the Project wants to achieve is to alleviate the vulnerability of valleys and local community to flooding and promote local economic development.

#### 3.3.1 Solving Measures for the Main Problem

##### (1) Main objective

Soothe the valleys and local community to flooding vulnerability.

##### (2) Direct and indirect measures

In table 3.3.1-1, direct and indirect solutions measures for the problem are shown.

**Table 3.3.1-1 Direct and indirect solution measures to the problem**

Direct measures	1. Analyze and relieve excessive flood flow	2. Prevent overflow	3. Full compliance with maintenance of flood control works	4. Encourage community flood prevention
Indirect measures	1.1 Analyze extraordinary weather (El Niño, etc..)	2.1 Construct flood control works	3.1 Strengthen maintenance knowledge and skills	4.1 Strengthen knowledge and skills to prevent flooding
	1.2 Analyze extraordinary rainfall in the upper and middle basins	2.2 Provide resources for the works construction	3.2 Reinforce training maintenance	4.2 Running flood prevention training
	1.3 Planting vegetation on the upper and middle basins	2.3 Develop plans for flood control basins	3.3 Maintain and repair dikes and margins	4.3 Creating early warning system
	1.4 Relieve Excessive sediment entrainment from the upper and middle river dikes	2.4 Build dikes	3.4 Repair intake and derivation works	4.4 Strengthen monitoring and water data collection
	1.5 Take steps to alleviate the reduction in hydraulic capacity of rivers by altering slopes, etc.	2.5 Extends the width of the channel	3.5 Control the illegal use of bed for agricultural purposes	
		2.6 Excavation of bed	3.6 Increase the maintenance budget	
		2.7 Extending the river at the bridge's construction		
		2.8 Dredging at the point of the bridge construction		
		2.9 Control dikes and margins erosion		
		2.10 Strengthen the capacity for works design		

#### 3.3.2 Expected Impacts for the Main's Objective Fulfillment

##### (1) Final impact

The final impact that the Project wants to achieve is to alleviate the vulnerability of the valleys and the local community to floods and promoting local socio-economic development.



## (2) Direct and indirect impacts

In table 3.3.2-1 direct and indirect impacts expected to fulfill the main objective to achieve the final impact are shown.

**Table 3.3.2-1 Ddirect and indirect impacts**

Direct Impacts	1. Agricultural damage relief	2. Relief of direct harm to the community	3. Relief of social infrastructure damage	4. Relief of other economic damage
Indirect Impacts	1.1 Relief to crops and livestock damage	2.1 Housing and private properties loss prevention	3.1 Road destruction prevention	4.1 Traffic interruption prevention
	1.2 Relief for farmland loss	2.2 Prevention of Industries and facilities establishments	3.2 Prevention of bridges loss	4.2 Reducing costs of flood prevention and evacuation
	1.3 Prevention of the destruction of irrigation channels	2.3 Prevention of accidents and human life loss	3.3 Running water, electricity, gas and communication infrastructures' relief	4.3 Cost reduction of the reconstruction and emergency measures
	1.4 Prevention of destruction works of intake and derivation	2.4 Commercial loss relief		4.4 Increase of local community hiring
	1.5 Dikes and margins erosion relief			4.5 Community income increase
				4.6 Life quality improvement
				4.7 Economic activities development

### 3.3.3 Measures - Objectives – Impacts Diagram

In Figure 3.3.3-1 the measures - objectives – impacts diagram is shown.

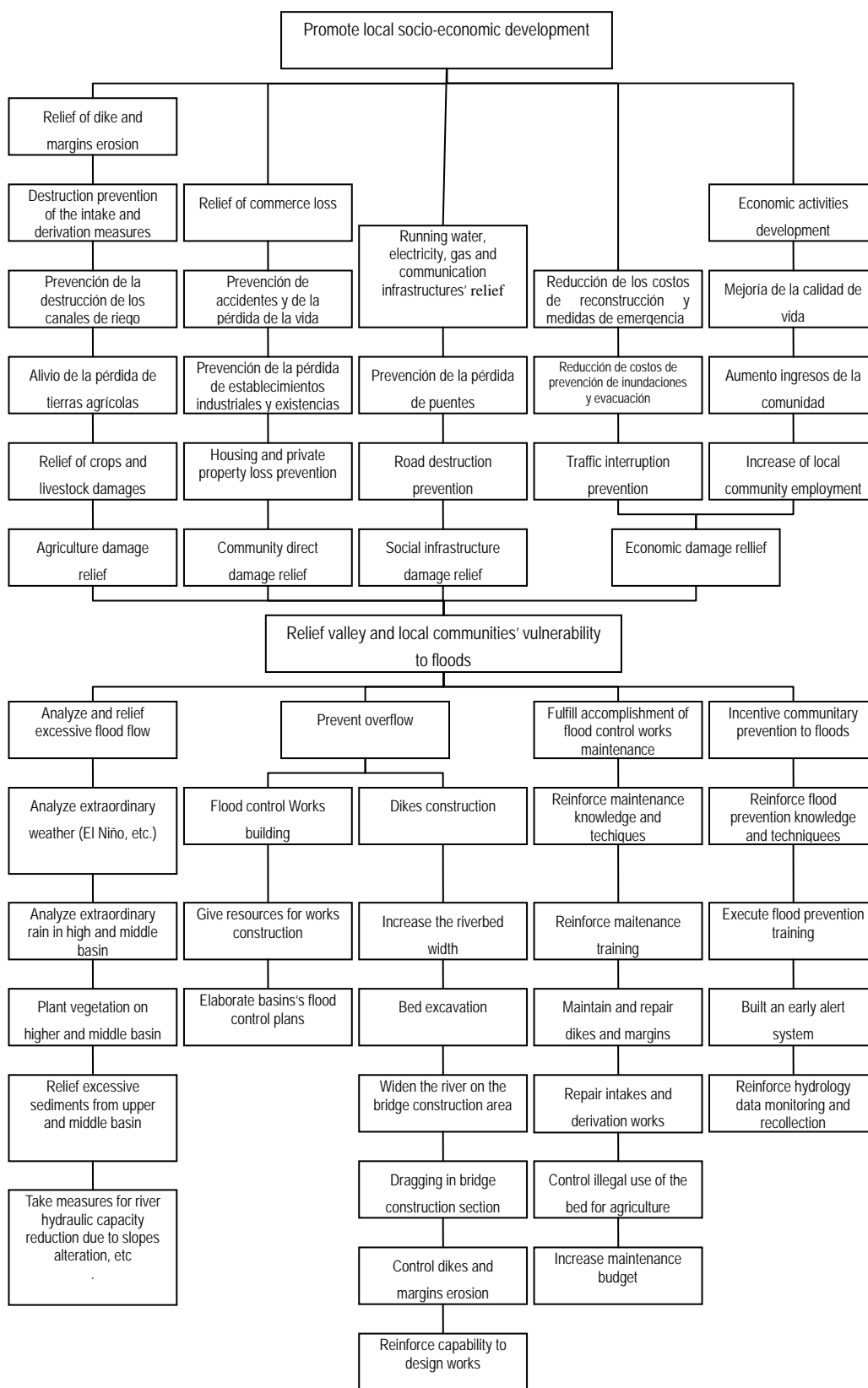

Figure 3.3.3-1 Measures - objectives – impacts diagram

## 4. FORMULATION AND EVALUATION

### 4.1 Definition of the Assessment Horizon of the Project

The Project's assessment horizon will be of 15 years, same as the one applied on the Program Profile Report. The Annex-10 of SNIP regulation stipulates that the assessment horizon should be basically 10 years; however the period can be changed in case that the project formulator (DGIH in this Project) admits the necessity of change. DGIH adopted 15 years in the Program Profile Report and OPI and DGPM approved it in March 19, 2010. In JICA's development study it should be generally 50 years, so the JICA Study Team inquired on the appropriate period to DGIH and OPI, they directed JICA Study Team to adopt 15 years. And the social evaluation in case of 50 years assessment horizon is described in Annex-14 Implementation Program of Japanese Yen Loan Project.

#### 4.2 4.2 Supply and Demand Analysis

The theoretical water level was calculated considering flowing design flood discharge based on river cross sectional survey executed with a 500m interval, in each Watershed, considering a flood discharge with a return period of 50 years. Afterwards, the dike height was determined as the sum of the design water level plus the freeboard of dike.

This is the dike height required to prevent damages caused by design floods and represents the local community demand indicator. The height of the existing dike or the height of the present ground is that required to prevent present flood damages, and represents the present supply indicator. The difference between the design dike (demand) and the height of the present dike or ground represents the difference or gap between demand and supply.

Table 4.2-1 shows the averages of flood water level calculated with a return period of 50 years in "3.1.9 Run-off Analysis"; of the required dike height (demand) to control the discharge adding the design water level plus the freeboard dike; the dike height or that of the present ground (supply), and the difference between these last two (difference between demand-supply) of the river. Then, Table 4.2-2 shows the values of each point in Pisco river. The dike height or that of the present ground is greater than the required dike height, at certain points. In these, the difference between supply and demand was considered null.

**Table 4.2-1 Watershed demand and supply**

Watershed	Dike Height / current land (supply)		Theoretical water level with a return period of 50 years	Dike Freeboard	Required dike's height (demand)	Diff. demand/supply	
	Left bank	Right bank				Left bank	Right bank
	①	②				③	④
Pisco	219.72	217.26	214.82	1.00	215.82	0.63	0.76

**Table 4.2-2 Demand and Supply according to calculation (Pisco river)**

Distance (km)	Present Height of Embankment or Ground (supply)		Flood Water level of 1/50Year Probability	Freeboard of Embankment	Required Height of Embankment (demand)	Supply and Demand Gap		(m)
	Left Bank	Right Bank				Left Bank	Right Bank	
	①	②				③	④	
0.0	2.47	2.71	3.30	1.00	4.30	1.83	1.59	
0.5	3.80	5.11	4.12	1.00	5.12	1.31	0.00	
1.0	5.28	5.20	5.76	1.00	6.76	1.48	1.56	
1.5	7.89	8.34	8.65	1.00	9.65	1.76	1.31	
2.0	13.15	11.82	12.16	1.00	13.16	0.00	1.34	
2.5	16.51	14.57	15.80	1.00	16.80	0.29	2.23	
3.0	25.64	19.07	19.62	1.00	20.62	0.00	1.55	
3.5	24.20	23.61	23.54	1.00	24.54	0.34	0.93	
4.0	27.00	26.93	27.51	1.00	28.51	1.51	1.58	
4.5	31.55	31.66	31.43	1.00	32.43	0.88	0.77	
5.0	37.35	37.31	36.54	1.00	37.54	0.19	0.23	
5.5	40.53	40.09	40.35	1.00	41.35	0.82	1.28	
6.0	44.98	43.66	44.45	1.00	45.45	0.47	1.79	
6.5	49.78	48.97	48.52	1.00	49.52	0.00	0.55	
7.0	56.31	56.69	52.72	1.00	53.72	0.00	0.00	
7.5	56.28	55.40	55.91	1.00	56.91	0.63	1.51	
8.0	60.66	60.23	59.52	1.00	60.52	0.00	0.28	
8.5	64.92	64.20	64.49	1.00	65.49	0.56	1.29	
9.0	69.49	69.05	68.58	1.00	69.58	0.09	0.53	
9.5	73.22	73.24	73.13	1.00	74.13	0.91	0.88	
10.0	78.17	87.08	76.49	1.00	77.49	0.00	0.00	
10.5	79.60	79.39	80.30	1.00	81.30	1.70	1.91	
11.0	85.06	84.53	84.78	1.00	85.78	0.72	1.25	
11.5	91.61	89.30	89.65	1.00	90.65	0.00	1.35	
12.0	96.04	94.38	94.58	1.00	95.58	0.00	1.20	
12.5	99.09	98.36	98.76	1.00	99.76	0.67	1.39	
13.0	103.98	103.27	103.65	1.00	104.65	0.68	1.38	
13.5	107.23	108.24	108.74	1.00	109.74	2.51	1.50	
14.0	112.45	113.10	113.75	1.00	114.75	2.29	1.64	
14.5	118.77	116.28	117.30	1.00	118.30	0.00	2.02	
15.0	125.85	122.38	122.20	1.00	123.20	0.00	0.82	
15.5	126.60	126.39	126.52	1.00	127.52	0.92	1.13	
16.0	131.82	131.42	131.71	1.00	132.71	0.89	1.29	
16.5	136.08	136.32	136.65	1.00	137.65	1.57	1.34	
17.0	143.80	141.45	142.09	1.00	143.09	0.00	1.64	
17.5	147.98	147.40	147.30	1.00	148.30	0.31	0.89	
18.0	151.54	152.41	152.32	1.00	153.32	1.77	0.91	
18.5	157.07	155.95	156.77	1.00	157.77	0.70	1.82	
19.0	166.46	161.42	161.94	1.00	162.94	0.00	1.52	
19.5	166.46	168.01	167.92	1.00	168.92	2.46	0.91	
20.0	173.43	174.70	173.49	1.00	174.49	1.06	0.00	
20.5	178.93	179.30	179.59	1.00	180.59	1.66	1.29	
21.0	184.96	187.88	185.15	1.00	186.15	1.19	0.00	
21.5	190.89	190.81	190.91	1.00	191.91	1.02	1.10	
22.0	196.74	196.23	196.34	1.00	197.34	0.60	1.11	
22.5	201.23	202.48	202.07	1.00	203.07	1.84	0.59	
23.0	208.45	208.82	208.47	1.00	209.47	1.01	0.65	
23.5	212.59	214.69	212.69	1.00	213.69	1.10	0.00	
24.0	218.64	219.69	218.85	1.00	219.85	1.21	0.16	
24.5	224.51	225.32	224.45	1.00	225.45	0.94	0.13	
25.0	229.61	231.33	229.69	1.00	230.69	1.07	0.00	
25.5	236.02	235.32	235.64	1.00	236.64	0.62	1.32	
26.0	241.27	241.61	241.33	1.00	242.33	1.06	0.72	
26.5	247.52	256.44	247.48	1.00	248.48	0.96	0.00	
27.0	254.12	263.85	251.69	1.00	252.69	0.00	0.00	
27.5	257.70	255.68	257.05	1.00	258.05	0.35	2.37	
28.0	261.99	262.22	262.55	1.00	263.55	1.56	1.33	
28.5	267.82	268.20	268.44	1.00	269.44	1.62	1.24	
29.0	274.48	274.33	274.80	1.00	275.80	1.32	1.47	
29.5	281.84	280.46	280.56	1.00	281.56	0.00	1.10	
30.0	291.17	316.87	290.00	1.00	291.00	0.00	0.00	
30.5	292.63	320.90	292.30	1.00	293.30	0.67	0.00	
31.0	300.50	298.22	298.01	1.00	299.01	0.00	0.79	
31.5	306.03	304.11	304.24	1.00	305.24	0.00	1.13	
32.0	308.19	311.58	309.37	1.00	310.37	2.18	0.00	
32.5	318.33	322.80	317.35	1.00	318.35	0.02	0.00	
33.0	325.11	329.73	323.46	1.00	324.46	0.00	0.00	
33.5	331.02	330.64	330.17	1.00	331.17	0.15	0.53	
34.0	348.32	337.51	335.88	1.00	336.88	0.00	0.00	
34.5	343.73	344.76	341.81	1.00	342.81	0.00	0.00	
35.0	351.25	354.05	352.39	1.00	353.39	2.14	0.00	
35.5	359.29	357.35	357.63	1.00	358.63	0.00	1.28	
36.0	402.55	363.51	363.73	1.00	364.73	0.00	1.22	
36.5	371.86	373.96	370.13	1.00	371.13	0.00	0.00	
37.0	375.78	379.66	376.03	1.00	377.03	1.25	0.00	
37.5	425.76	386.95	382.44	1.00	383.44	0.00	0.00	
38.0	432.47	393.78	389.60	1.00	390.60	0.00	0.00	
38.5	439.56	400.77	395.90	1.00	396.90	0.00	0.00	
39.0	449.06	402.74	402.74	1.00	403.74	0.00	1.00	
39.5	457.67	413.14	408.67	1.00	409.67	0.00	0.00	
40.0	449.76	421.44	416.83	1.00	417.83	0.00	0.00	
40.5	441.31	430.28	422.24	1.00	423.24	0.00	0.00	
41.0	437.72	434.93	429.32	1.00	430.32	0.00	0.00	
41.5	447.00	441.37	437.31	1.00	438.31	0.00	0.00	
42.0	453.31	451.72	443.63	1.00	444.63	0.00	0.00	
42.5	455.27	450.09	450.24	1.00	451.24	0.00	1.15	
43.0	464.45	464.02	456.92	1.00	457.92	0.00	0.00	
43.5	472.01	489.37	464.80	1.00	465.80	0.00	0.00	
44.0	483.96	480.24	470.90	1.00	471.90	0.00	0.00	
44.5	484.27	485.63	478.17	1.00	479.17	0.00	0.00	
45.0	495.46	494.34	485.30	1.00	486.30	0.00	0.00	
Average	219.72	217.26	214.82	1.00	215.82	0.63	0.76	

### **4.3 Technical Planning**

#### **4.3.1 Structural Measures**

As structural measures it was necessary to prepare a flood control plan for the whole Watershed. The later section 4.15 “Medium and Long Term Plan” and 4.15.1 “General Flood Control Plan” details results on the analysis. This plan proposes the construction of dikes for flood control in the entire Watershed. However, in the case of the Watershed of Pisco river, a big project needs to be set up investing very high costs, far beyond those considered in the budget of the present Project, what makes it difficult to take this proposal. Therefore, supposing the flood control dikes in the whole Watershed are built progressively within a medium and long term plan, they would be focused on the study of more urgent and priority works for flood control.

##### **(1) Design flood discharge**

###### 1) Guideline for flood control in Peru

The Methodological Guide for Projects on Protection and/or Flood Control in Agricultural or Urban Areas prepared by the Public Sector Multiannual Programming General Direction (DGPM) (present DGPI) of the Economy and Finance Ministry (MEF) recommends to carry out the comparative analysis of different return periods: 25 years, 50 years and 100 years for the urban area, and 10 years, 25 years and 50 years for rural area and agricultural lands.

Considering that the present Project is focused on the protection of rural and agricultural areas, the design flood discharge should be the discharge with return period of 10year to 50-year.

###### 2) Maximum discharge in the past and design flood discharge

The yearly maximum discharge in each watershed is as shown in Figure-4.3.1-1. Based on the figures, the maximum discharge in the past can be extracted as shown in the Table- 4.3.1-1 together with the flood discharges with different return periods.

The maximum discharge in the past in the watershed occurred one times of which scale is same as the flood discharge with return period of 50-year. And it is true that the flood discharges of same scale as the flood discharge with return period of 50-year caused large damages in the past. The maximum flood in the past is same as or less than the flood discharge with return period of 50-year.

Since the flood control facilities in Peru not well developed, it is not necessary to construct the facilities for more than the maximum discharge in the past, however it is true that the past floods caused much disaster so that the facilities should be safe for the same scale of flood, therefore the design flood discharge in this Project is to be the discharge with return period of 50-year.

**Table - 4.3.1-1 Flood discharge with different return period(m<sup>3</sup>/sec)**

<b>Watershed</b>	<b>2-year</b>	<b>10-year</b>	<b>25-year</b>	<b>50-year</b>	<b>100-year</b>	<b>Max. in the Past</b>
Pisco	213	451	688	855	963	956

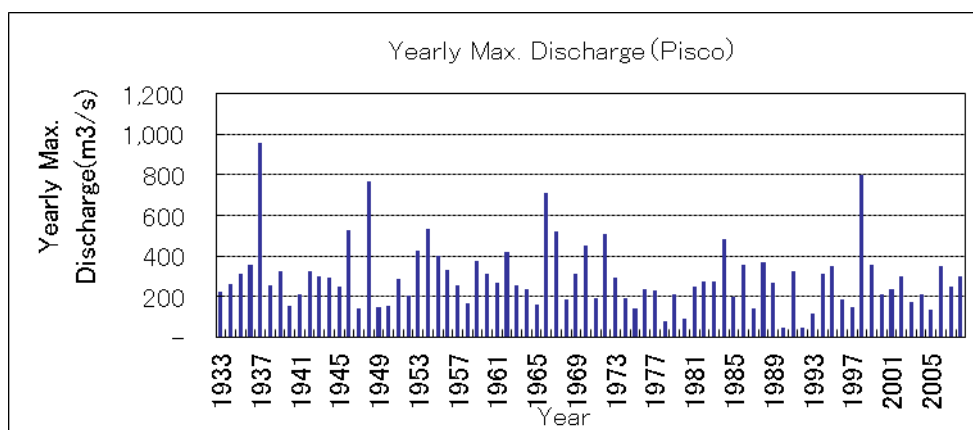

**Figure- 4.3.1-1 Yearly max. discharge (Pisco)**

3) Relation among probable flood, damage and inundation area

The relation among probable flood, Damage and inundation area in the watershed are shown in the Figure-4.3.1-2.

Based on the figure the following facts can be expressed.

- ① The more increase probable flood discharge, the more increase inundation area (green line in the figure).
- ② The more increase probable flood discharge, the more increase damage (red line in the figure).
- ③ According to increase of probable flood discharge, the damage with project increase gently (blue line in the figure).
- ④ According to increase of probable flood discharge, damage reduction (difference between red line and blue line) increase steadily, and it reaches maximum at the probable flood of 50- year within the scope of study.

As shown in the above section, the design flood discharge with return period of 50-year is almost equal to the maximum flood in the past, and absolute damage reduction amount in the design discharge is largest among the probable flood discharge less than with return period of 50-year, and economic viability of the design flood is confirmed. Although the design discharge is the flood with return period of 50-year, the inundation area of the flood with return period of 100-year is described in the figures.

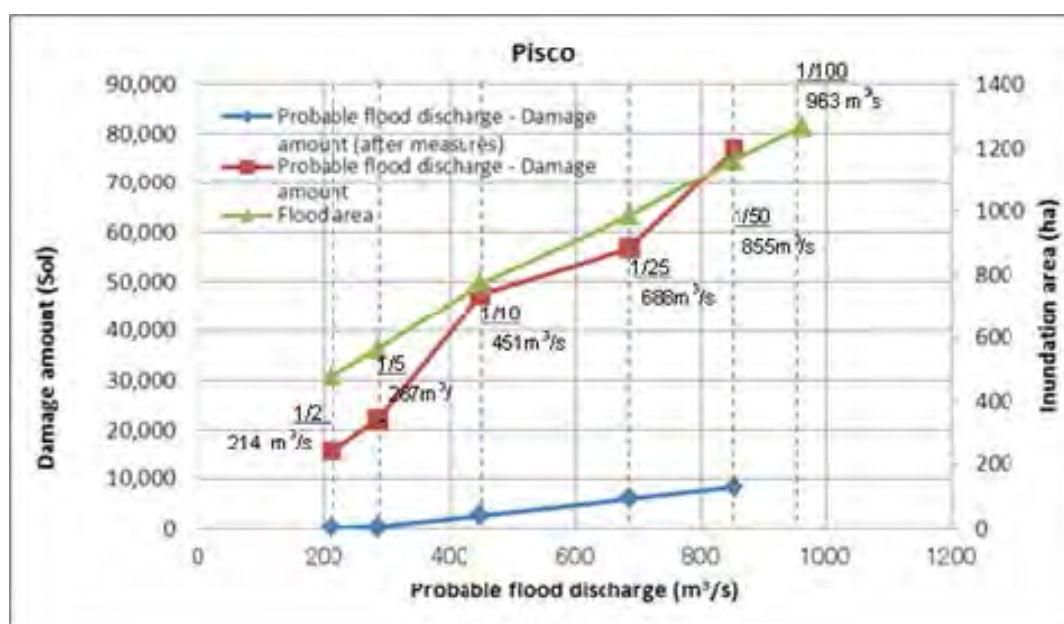

**Figure— 4.3.1-2 Probable flood discharge, damage amount and inundation area (Pisco river)**

### (2) Topographical survey

The topographical survey was carried out in selected places for the execution of structural measurements (Table 4.3.1-2). The preliminary design of control works was based on these topographical survey results.

**Table 4.3.1-1 Profile of topographical survey**

River	Location (No.)	Installations	Topo lift.	Transversal Lifting (S=1/200)		
			(ha)	Line No.	Middle length (m)	Total length (m)
Pisco	Pi-1	Dike	10.0	21	50.0	1,050
	Pi-2	Dike & excavation	30.0	16	200.0	3,200
	Pi-3	Dike	7.5	16	50.0	800
	Pi-4	Dike	5.0	11	50.0	550
	Pi-5	Reservoir	30.0	11	300.0	3,300
	Pi-6	Reservoir	100.0	21	500.0	10,500
Total			182.5	96		19,400

### (3) Selection of flood protection works with high priority

#### 1) Basic guidelines

For the selection of priority flood protection works, the following elements were considered:

- Demand from the local community (based on historical flood damage)
- Lack of discharge capacity of river channel (including the sections affected by the scouring)

- Conditions of the adjacent area (conditions in urban areas, farmland, etc.).
- Conditions and area of inundation (type and extent of inundation according to inundation analysis)
- Social and environmental conditions (important local infrastructures)

Based on the river survey, field investigation, discharge capacity analysis of river channel, inundation analysis, and interviews to the local community (irrigation committee needs, local governments, historical flood damage, etc...) a comprehensive evaluation was made applying the five evaluation criteria listed above. After that we selected a total of six (6) critical points (with the highest score in the assessment) that require flood protection measures.

Concretely, since the river cross sectional survey was carried out every 500m interval and discharge capacity analysis and inundation analysis were performed based on the survey results, the integral assessment was also done for sections of 500 meters. This sections have been assessed in scales of 1 to 3 (0 point, 1 point and 2 points) and the sections of which score is more than 6 were selected as prioritized areas. The lowest limit (6 points) has been determined also taking into account the budget available for the Project in general. Table 4.3.1-3 details evaluated aspects and assessment criteria.

**Table 4.3.1-3 Assessment aspects and criteria**

Assessment Aspects	Description	Assessment Criteria
Demand of local population	<ul style="list-style-type: none"> <li>● Flood damages in the past</li> <li>● Demand of local population and producers</li> </ul>	<ul style="list-style-type: none"> <li>• Flooding area with big floods in the past and with great demand from local community (2 points)</li> <li>• Demand of local population (1 point)</li> </ul>
Lack of discharge capacity (bank scouring)	<ul style="list-style-type: none"> <li>● Possibility of river overflow given the lack of discharge capacity</li> <li>● Possibility of dike and bank collapse due to scouring</li> </ul>	<ul style="list-style-type: none"> <li>• Extremely low discharge capacity (discharge capacity with return period of 10 years or less) (2 points)</li> <li>• Low discharge capacity (with return period of less than 25 years) (1 point)</li> </ul>
Conditions of surrounding areas	<ul style="list-style-type: none"> <li>● Large arable lands, etc.</li> <li>● Urban area, etc.</li> <li>● Assessment of lands and infrastructure close to the river.</li> </ul>	<ul style="list-style-type: none"> <li>• Area with large arable lands (2 points)</li> <li>• Area with arable lands mixed with towns, or big urban area (2 points)</li> <li>• Same configuration as the previous one, with shorter scale (1 point)</li> </ul>
Inundation conditions	<ul style="list-style-type: none"> <li>● Inundation magnitude</li> </ul>	<ul style="list-style-type: none"> <li>• Where overflow extends on vast surfaces (2 points)</li> <li>• Where overflow is limited to a determined area (1 point)</li> </ul>
Socio-environmental conditions (important structures)	<ul style="list-style-type: none"> <li>● Intake of the irrigation system, drinking water, etc.</li> <li>● Bridges and main roads (Carretera Panamericana, etc.)</li> </ul>	<ul style="list-style-type: none"> <li>• Where there are important infrastructures for the area (2 points)</li> <li>• Where there are important infrastructures (but less than the first ones) for the area (regional roads, little intakes, etc.) (1 point)</li> </ul>

## 2) Selection results

Figure 4.3.1-3 details assessment results of each the river, as well as the selection results of flood protection priority works.



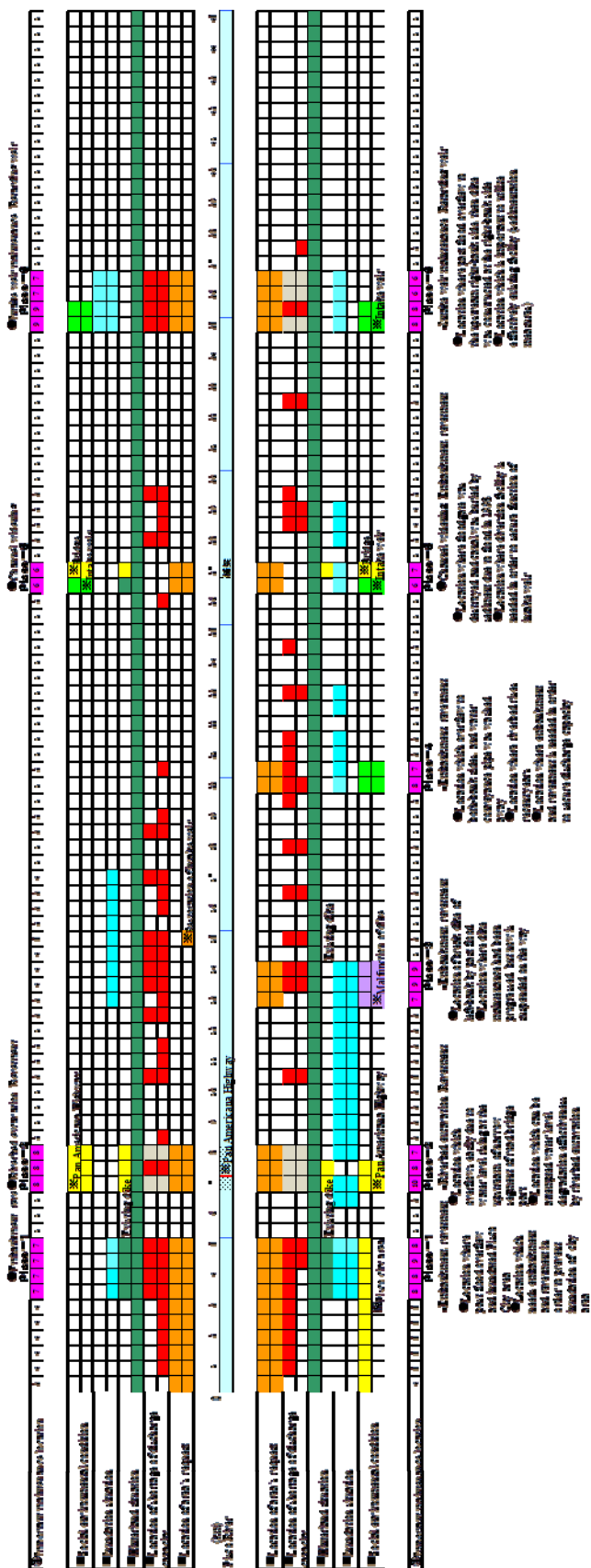

Figure 4.3.1-3 Selection results of prioritized flood protection works in Pisco river

### 3) Basis of selection

At the section from the river mouth to 7km upstream, the water inundates farmland nearby due to lack of discharge capacity, but not extending beyond. However, when the inundation occurs in the lower reach (from the mouth to 7 km), the water inundates large areas of the left bank causing serious damage in urban areas of Pisco. Therefore at the downstream section from 7km, the embankment is executed in the section with highest risk of inundation and at the upstream area countermeasures in the sections with low discharge capacity such as bridges and intake.

At the Pan-American road the river width is narrowed, so that the widening the river width with building new bridge is considered, however taking account of the large traffic volume, necessity of access road to the bridge causing large cost, and that DGIH judged that the construction of new bridge is difficult for demarcation of administrative responsibility among Ministries, the construction of new bridge is not adopted in this Project.

**Table 4.3.1-4 Selected sections bases to execute works (Pisco river)**

No	Location	Basis of Selection
①	3.0km~5.0km (both banks))	<p>In this section once the inundation reaches urban area, the influence to the regional economy will be serious. And in case that the flood protection work is constructed in the upstream section, inundation occurs and enlarges in the right bank. And this section the river meanders so that slope and end of slope are to be protected. Therefore the embankment at both banks is required. And also it should be taken note that the existing dikes were constructed from 5.0km ~5.5km at both banks.</p> <p>[Characteristics of the section]</p> <ul style="list-style-type: none"> <li>● Section that inundation occurred in the past flood to the city of Pisco.</li> <li>● Section where it is needed to build embankment with bank protection to prevent inundation of the city.</li> <li>● Section in which the inundation will be extended on the right bank in the case that the flood prevention work is performed in the upstream.</li> </ul> <p>[Elements to protect]</p> <ul style="list-style-type: none"> <li>○ Large agricultural land extending to both sides of the section in question</li> <li>○ The city of Pisco to the left of the section in question</li> </ul> <p>[Method of Protection]</p> <ul style="list-style-type: none"> <li>▼ Inundation occurs at the flood with return period of 5-year and the damage become heavily at the flood with return period of 50-year (nearly equal to 950m<sup>3</sup>/sec causing maximum damages) , so that the flood protection work is implemented for the latter flood flowing down safely.</li> <li>▼ Embankment with bank protection is to be constructed with consideration of upstream and downstream reach and land acquisition.</li> </ul>
②	6.5km~8.0km (riverbed excavation)	<p>The section in question is the narrow section of the river where it crosses the bridge, and sediment deposits and discharge capacity is insufficient.</p> <p>Damming up of water causes the elevation of the water level in the upper section. Since it is impossible to reconstruct the bridge it is required to dredge</p>

		<p>the bed around the bridge site to increase discharge capacity and lower the water level in the upper section.</p> <p>[Characteristics of the section]</p> <ul style="list-style-type: none"> <li>● Section narrow (where the road bridge) in which the discharge capacity is insufficient.</li> <li>● Section in which sediments have accumulated in the upper due to the damming up effect.</li> <li>● Section which may reduce the water level in the upper bed by river bed excavation.</li> </ul> <p>[Elements to protect]</p> <ul style="list-style-type: none"> <li>○ Farmland extending to the left bank of the section in question and on the upper section.</li> </ul> <p>[Method of Protection]</p> <ul style="list-style-type: none"> <li>▼ Insufficient discharge capacity promote the inundation of the upstream so that the facility which can discharge the flood with return period of 50-year(nearly equal to 950m<sup>3</sup>/sec causing maximum damages) is to be performed.</li> <li>▼ The discharge capacity is to be secured by riverbed excavation, and without rebuilding the Pan-American bridge.</li> </ul>
③	12.5km~14.0km (left bank)	<p>In this section the discharge capacity is lowest at the left bank, and is likely to inundate frequently even with a small scale of flooding. In the event of major floods, the damage can be severe, so it is urgent to build dikes with bank protection.</p> <p>On the other hand, given that a new dike between km14. 5-km 14. 0, taking the necessary precautions for the connection of the dikes.</p> <p>[Characteristics of the section]</p> <ul style="list-style-type: none"> <li>● Section in which the embankment was destroyed on the left bank by flooding.</li> <li>● Section in which the construction of the embankment was suspended on the way.</li> </ul> <p>[Elements to protect]</p> <ul style="list-style-type: none"> <li>○ Cropland to both sides of the section in question.</li> </ul> <p>[Method of Protection]</p> <ul style="list-style-type: none"> <li>▼ Inundation occurs at the flood with return period of 5-year and the damage become heavily at the flood with return period of 50-year, so that the flood protection work is implemented for the latter flood flowing down safely.</li> <li>▼ The embankment with bank protection is executed in the section in which the height of dike is not enough utilizing the existing dikes and condition of natural grand.</li> </ul>
④	19.5km~20.5km (left bank)	<p>In this section the discharge capacity is lowest at the left bank, and is likely to inundate frequently even with a small scale of flooding. In the event of major</p>

		<p>floods, the damage can be severe, so it is urgent to build dikes with bank protection.</p> <p>[Characteristics of the section]</p> <ul style="list-style-type: none"> <li>● No embankment section where inundate occurs on both banks and the water conveyance pipe leading to Pisco was lost.</li> <li>● Section in which the river bed is raising in recent years.</li> <li>● Section where embankment with bank protection is required to recover adequate discharge capacity.</li> </ul> <p>[Elements to protect]</p> <ul style="list-style-type: none"> <li>○ Cropland on the left bank of the section in question.</li> <li>○ Water conveyance pipe to Pisco (important facility).</li> </ul> <p>[Method of Protection]</p> <p>▼ Inundation occurs at the flood with return period of 5-year and the damage become heavily at the flood with return period of 50-year, so that the flood protection work is implemented for the latter flood flowing down safely. And the conservation of water conveyance pipe to Pisco.</p> <p>▼ The embankment with bank protection is executed in the section in which the height of dike is not enough utilizing the existing dikes and condition of natural grand.</p>
⑤	26.0km~27.0km (widening river width to the left bank)	<p>In this section it is important to keep the operational function of the existing intake. The gate was destroyed in the floods of the past, and the accumulation of sediment has left irrigation channels inoperative. Therefore, it is necessary to build a bypass work at km26. 75point (upstream of the intake) to allow water to flow towards the right bank at the time of low water and let more water flow to the left in the flood season.</p> <p>[Characteristics of the section]</p> <ul style="list-style-type: none"> <li>● Section where the gate was destroyed by the 1998 floods also being buried the irrigation channel.</li> <li>● Section which requires to build the bypass to protect the operation of the intake.</li> </ul> <p>[Elements to protect]</p> <ul style="list-style-type: none"> <li>○ Intake on the right bank of the section in question</li> </ul> <p>[Method of Protection]</p> <p>▼ This intake is the most important in the river. The influence to the region is very big in case of lost function so that the protection work should be safe in the flood of 950m<sup>3</sup>/sec which caused serious damage in the past and nearly equal to the flood with return period of 50-years.</p> <p>▼ There are no existing dikes in this section so that the river width can be widened considering the condition of upstream and downstream and land</p>

		acquisition.
⑥	34.5km~36.5km (total)	<p>The site of the weir built at the km34.5 is a narrow section, and has accumulated large amounts of sediment upstream. It is considered necessary to effectively use this weir, and take the upper reservoir of the weir as retarding basin when floods occur which exceed the magnitude of design.</p> <p>Intends to use the existing weir to retard the flood exceeding the design scale and at the same time, reduce sediment transport.</p> <p>Ideally, to achieve progressively a degree of safety on the order of 1/50 years from downstream. However, for the moment it is important to make effective use of existing structures where possible to control water flow exceeding the design scale (return period of 50 years).</p> <p>[Characteristics of the section]</p> <ul style="list-style-type: none"> <li>● Section where inundation occurred in the upstream right bank of the weir in the past floods.</li> <li>● Section where it is important to effectively use existing works (sediment control, etc.).</li> </ul> <p>[Elements to protect]</p> <ul style="list-style-type: none"> <li>○ The entire area downstream of the section in question.</li> </ul> <p>[Method of Protection]</p> <p>▼This section is located in the most upstream of the river and appropriate to control flood and sediment flow. The characteristics of Pisco river such that the inundation area increases gradually in accordance with the increase of flood discharge. However when the discharges over the discharge with return period of 50-years the damage increases greatly. Once the discharge more than the discharge with return period of 50-years, the more the damage increases. Therefore it is important to prepare for flood over the return period of 50 years. In that case the excess of design flood and sediment flow are to be reserved in this section.</p>

#### **(4) Location of prioritized flood control works**

In Figure 4.3.1-4 the location of prioritized flood control works is indicated in the watershed and in the Table- 4.3.1-5 the summary of flood control works is indicated..

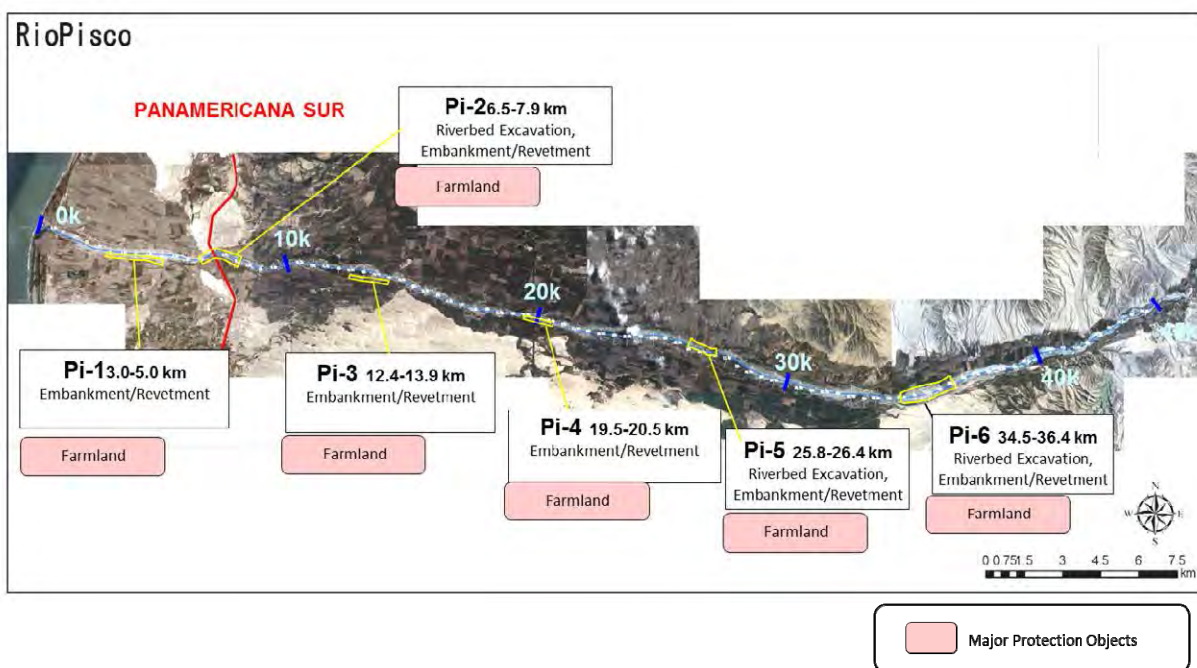

Figure 4.3.1-4 Prioritized flood control works in Pisco River

Table 4.3.1-5 Summary of facilities

River	Location		Critical Point	Main Protection Objects	Measure	Feature of Work		
Rio Pisco	Pi-1	3.0-5.0 km	Innuded Point	Agricultural Lands	Dike with Bank Protection	Length	4,120 m	
						Dike with Bank Protection		92,900 m <sup>3</sup>
						Large Boulder Riplap		32,200 m <sup>3</sup>
	Pi-2	6.5-7.9 km	Narrow Section		Riverbed Excavation	Riverbed excavation	L=1,200 m, V=74,900 m <sup>3</sup>	
					Dike with Bank Protection	Dike with Bank Protection	L=2,950 m, V=42,520 m <sup>3</sup>	
					Large Boulder Riplap	Large Boulder Riplap	25,000 m <sup>3</sup>	
Pi-3	12.4-13.9 km	Innuded Point		Dike with Bank Protection	Length	1,500 m		
					Dike with Bank Protection	33,900 m <sup>3</sup>		
					Large Boulder Riplap	12,600 m <sup>3</sup>		
Pi-4	19.5-20.5 km	Innuded Point		Dike with Bank Protection	Length	1,010 m		
					Dike with Bank Protection	17,400 m <sup>3</sup>		
					Large Boulder Riplap	8,060 m <sup>3</sup>		
Pi-5	25.8-26.4 km	Narrow Section		Riverbed Excavation	Riverbed excavation	L=600 m, V=67,600 m <sup>3</sup>		
				Dike with Bank Protection	Dike with Bank Protection	L=1,250 m, V=29,900 m <sup>3</sup>		
				Large Boulder Riplap	Large Boulder Riplap	10,600 m <sup>3</sup>		
Pi-6	34.5-36.4 km	Existing Intake Weir (Sediment Retuding Basin 1,800 x 700m)		Riverbed Excavation	Riverbed excavation	L=1,900 m, V=496,000 m <sup>3</sup>		
				Dike with Bank Protection	Outer Dike/ Bank protection	L=2,050 m, V=103,600 m <sup>3</sup>		
					Large Boulder Riplap	19,900 m <sup>3</sup>		
					Inner Dike/ Bank protection	L=3,750 m, V=114,000 m <sup>3</sup>		
					Large Boulder Riplap	63,100 m <sup>3</sup>		

### (5) Standard section of the dike

#### 1) Width of the crown

The width of the dike crown was defined in 4 meters, considering the dike stability when facing design overflows, width of the existing dike, and width of the access road or that of local communication.

#### 2) Dike structure

The dike structure has been designed empirically, taking into account historic disasters, soil

condition, condition of surrounding areas, etc.

Dikes are made of soil in all the Watersheds. Although there is a difference in its structure varying from area to area, this can be summarized as follows, based on the information given by the administrators interviewed:

- ① The gradient of the slope is mainly 1:2 (vertical: horizontal relationship); the form may vary depending on rivers and areas.
- ② Dike materials are obtained from the river bed in the area. Generally these are made of sand/gravel ~sandy soil with gravel, of reduced plasticity. As to the resistance of the materials, we cannot expect cohesiveness.
- ③ The Watershed of the Cañete River is made of loamy soil with varied pebble, relatively compacted.
- ④ The lower stretch of the Sullana weir of the Chira River is made of sandy soil mixed with silt. Dikes have been designed with a “zonal-type” structure where material with low permeability is placed on the riverside of the dike and the river; material with high permeability is placed on landside of the dike. However, given the difficulty to obtain material with low permeability, it has been noticed that there is lack of rigorous control of grain size distribution in supervision of construction.
- ⑤ When studying the damaged sections, significant differences were not found in dike material or in the soil between broken and unbroken dike. Therefore, the main cause of destruction has been water overflow.
- ⑥ There are groins in the Chira and Cañete rivers, and many of them are destroyed. These are made of big rocks, with filler material of sand and soil in some cases, what may suggest that destruction must be caused by loss of filler material.
- ⑦ There are protection works of banks made of big rocks in the mouth of the Pisco River. This structure is extremely resistant according to the administrator. Material has been obtained from quarries, 10 km. away from the site.

Therefore, the dike should have the following structure.

- ① Dikes will be made of material available in the zone (river bed or banks). In this case, the material would be sand and gravel or sandy soil with gravel, of high permeability. The stability problems forecasted in this case are as follows.
  - i) Infiltrate destruction caused by piping due to washing away fine material
  - ii) Sliding destruction of slope due to infiltrate pressure

In order to secure the stability of dike the appropriate standard section should be determined by infiltration analysis and stability analysis for sliding based on unit weight, strength and permeability of embankment material.

- ② The gradient of the slope of the dike will be between 30° ~35° (angle of internal friction) if the material to be used is sandy soil with low cohesiveness. The stable gradient of the slope of

an embankment executed with material with low cohesiveness is determined as:  $\tan\theta = \tan\phi/n$  (where “ $\theta$ ” is gradient of the slope; “ $\phi$ ” is angle of internal friction and “ $n$ ” is 1.5 ,safety factor).

The stable slope required for an angle of internal friction of  $30^\circ$  is determined as: V:H=1:2.6 ( $\tan\theta=0.385$ ).

Taking into consideration this theoretical value, a gradient of the slope of 1:3.0 was considered, with more gentle inclination than the existing dikes, considering the results of the discharge analysis, the prolonged time of the design flood discharge (more than 24 hours), the fact that most of the dikes with slope of 1:2 have been destroyed, and the relative resistance in case of overflow due to unusual flooding.

The infiltration analysis and stability analysis of dike based on the soil investigation and martial tests are not performed in this Study so that the slope is determined by simple stability analysis assuming the strength factors of dike material estimated by field survey of material and by adding some safety allowance.

And the slope of dike in Japan is generally 1:2.0 in minimum, however the average slope will be more than 1:3.0 because the dike has several steps in every interval of 2m~3m of height.

- ③ The dike slope by the riverside must be protected for it must support a fast water flow given the quite steep slope of the riverbed. This protection will be executed using big stones or big rocks easily to get in the area, given that it is difficult to get connected concrete blocks.

The size of the material was determined between 30cm and 1m of diameter, with a minimum protection thickness of 1m, although these values will be determined based on flow speed of each river.

- ④ The penetration depth to bank protection is to be i) difference height between the deepest riverbed in the past and present riverbed or ii) empirical depth (0.5m~1.5m in Japan), the former is u certain without chronological riverbed fluctuation data, therefore according to the latter the depth is to be 1.75m referring to the river channel improvement section in Ica river

- ⑤ Heightening Method of Dike

The heightening length of existing dike is 0.8 km among the total length of dike construction of 15.2 km in Pisco.

The heightening method of dike is basically an overall enlargement type due to the following reasons and the alignment of dike accords with the one of exiting dike.

i) The heightening method of widening dike in riverside decreases river width so that the discharge capacity is reduced resulting in raising height of dike more than the other methods.

ii) The heightening method of widening dike in land side requires more land acquisition. It is desirable that the land acquisition is to be reduced as much as possible because the land is mainly important agricultural land of expensive.

iii) Although the workmanship of dike construction such as the compaction



condition and material characteristics are unknown, the existing dike is to be utilized because the dike has been functioned in the past flooding, and the heightening method of overall enlargement type is to be applied, in which the existing dike is covered by the new dike with high strength, and can secure the safety and be economical with less land acquisition.

On the other hand, in the section with the narrow river width and river channel near to the dike, the heightening method of widening dike in land side is applied; in this case the riverside slope is protected with revetment.

### 3) Freeboard of the dike

The dike is made of soil material, and as such, it generally turns to be a weak structure when facing overflow. Therefore, it is necessary to prevent water overflow, to a lower water rise than the design discharge. So it is necessary to keep a determined freeboard when facing a possible increase in water level caused by the waves by the wind during water rise, tidal, hydraulic jump, etc. Likewise, it is necessary that the dikes have sufficient height to guarantee safety in surveillance activities and flood protection work, removal of logs and other carryback material, etc.

Table 4.3.1-6 shows guidelines applied in Japan regarding freeboard. Although in Peru there is a norm on freeboard, it has been decided to apply the norms applied in Japan, considering that rivers in both countries are alike.

**Table-4.3.1-9 Design discharge and freeboard**

Design discharge	Freeboard
Less than 200 m <sup>3</sup> /s	0.6m
More than 200 m <sup>3</sup> /s, less than 500 m <sup>3</sup> /s	0.8m
More than 500 m <sup>3</sup> /s, less than 2,000 m <sup>3</sup> /s	1.0 m
More than 2,000 m <sup>3</sup> /s, less than 5,000 m <sup>3</sup> /s	1.2 m
More than 5,000 m <sup>3</sup> /s, less than 10,000 m <sup>3</sup> /s	1.5 m
More than 10,000 m <sup>3</sup> /s	2.0 m

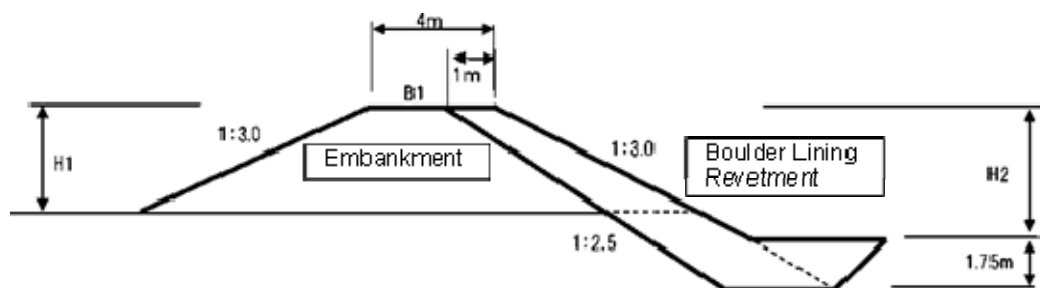

**Figure 4.3.1-5 Standard dike section**

4) Importance in construction work

The importance in dike construction is sufficient compaction of dike material. The cost estimate standard in Peru the compaction is to be made by tractor; however for the sufficient compaction it is desirable to use compaction equipment such as vibration roller etc.

And in order to supervise the compaction of material, the density test and grain size analysis are important, of which are specified in the technical specification of the tender document.

**(6) Effect of flood prevention facilities**

The discharge capacity of each river is enlarged up to the flood discharge with return period of 50-year by construction of the flood prevention facilities as shown in the Figure-4.3.1-6, and the inundation area is reduced remarkably.

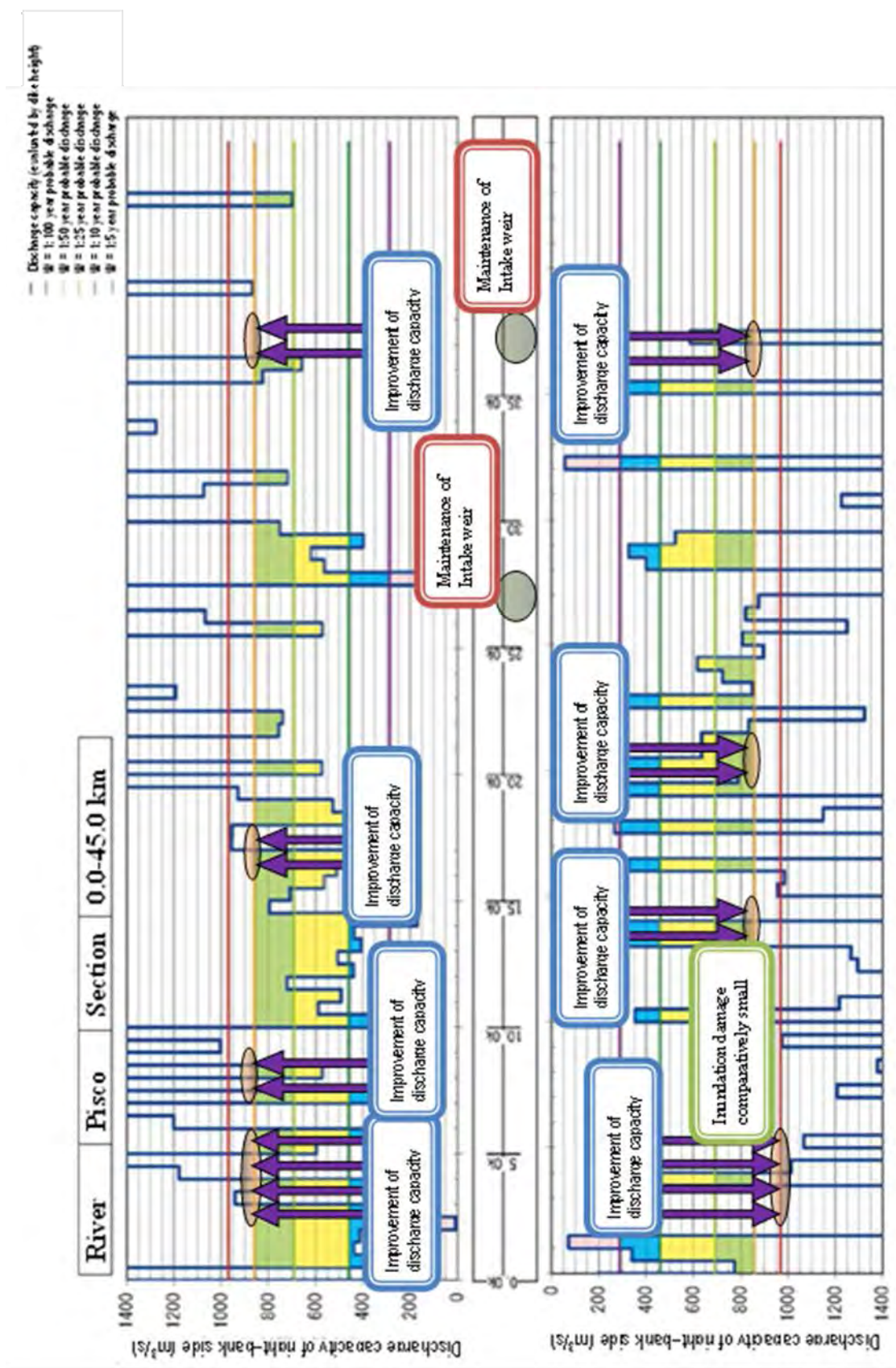

Figure-4.3.1-6 Effect of flood prevention facilities (Rio Pisco)

## **4.3.2 Nonstructural Measures**

### **4.3.2.1 Reforestation and Vegetation Recovery**

#### **(1) Basic policies**

The Reforestation and Vegetation Recovery Plan satisfying the goal of the present Project can be classified in: i) reforestation along fluvial works; and ii) reforestation in the high Watershed. The first one contributes directly to flood control and expresses its effect in short time. The second one demands a huge investment and an extended time, as detailed in the later section 4.15 “Medium and long term Plan”, 4.15.2 “Reforestation Plan and Vegetation Recovery”, what makes not feasible to implement it in the present Project. Therefore, the analysis is here focused only in option i).

#### **(2) Reforestation plan along river structures**

Policies for the afforestation plan along river structure is as shown below. The conceptual diagram of the afforestation scheme are shown in Figures 4.3.2.1-1.

- a) Objective: Reduce impact of river overflow when water rise occurs or when river narrowing is produced by the presence of obstacles, by means of vegetation borders between the river and the elements to be protected.
- b) Methodology: Create vegetation borders of a certain width between river structures and the river.
- c) Work execution: Plant vegetation at a side of the river structures (dikes, etc.) is to be a part of construction work of river structures, and which is carried out by the same contractor as for the river structures. The reasons are i) plant vegetation is to be certain for the withered damage just after plantation and ii) The same contractor for the river structures is appropriate due to the parallel work of plantation and structure construction.
- d) Maintenance post reforestation: The maintenance will be assumed by irrigation commissions by own initiative. In the past project, it is usually performed that the agreement is made between the irrigation committee and DGIH on the following two items.
  - i) The ownership of plantation belongs to the irrigation committee.
  - ii) Operation and maintenance cost of the plantation is born by the committeeTherefore the plantation is not private property but public one in the committee.
- e) Plantation section : Since the purpose of plantation is mitigation of damage in overflowing of flood, the plantation is to be made in the preventive side of dike. In case that the plantation is made in the section without dike, the trees are knocked down directly by flood water, and they flow down along river causing the choke in the bridges etc. resulting in secondary damage, and as the length without dike is long , the cost of construction and land acquisition increases.

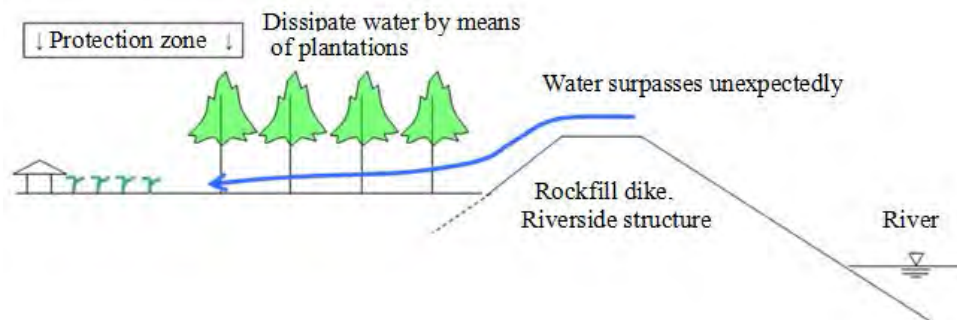
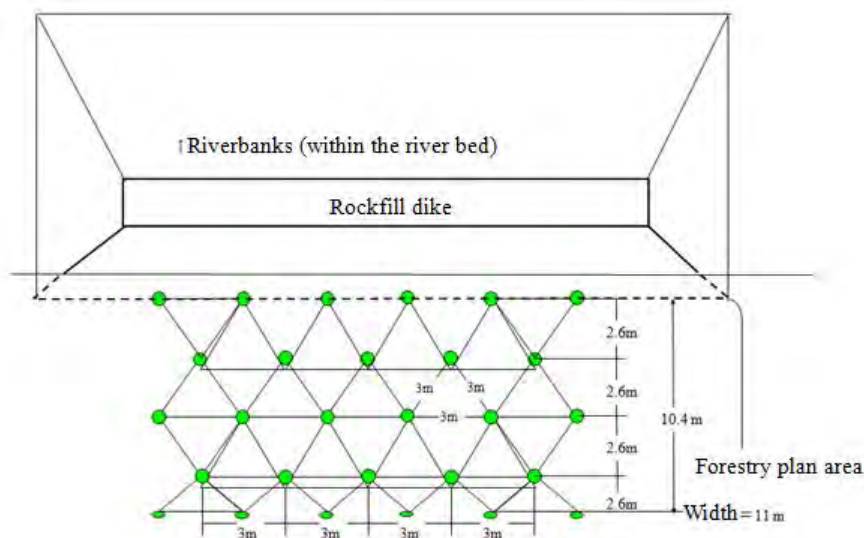

**Figure 4.3.2.1-1 Conceptual diagram afforestation in the riverside structures**  
 source: JICA Study Team)

### (3) Reforestation plan

#### 1) Structure (plantation arrangement)

In Peru the most common pattern for afforestation is with equilateral triangles. This project also uses this model by planting trees with 3-meter intervals (Figure 4.3.2.1-2). If this method is used, the interval of trees vertical to the dike will be 2.6m and in the case of zigzag arrangement, the width will be 1.3m of which interval can stop the boulder with diameter of 1m or dissipate the energy of the boulder. And 4 lines of trees can increase the effect. Thus the width of plantation zone will be 11 m adding the allowance to 10.4 m.



(Source: JICA Study Team)

**Figure 4.3.2.1-2 Arrangement of plantation along river structure**

## 2) Species to be forested

The following list of forestry species has been developed for selecting the species to be planted.

- Forestry species for production (information obtained by forest nursery companies): see Table 4.3.2.1-1
- Forestry species verified in situ: see Table 4.3.2.1-2.

The mentioned species are selected for afforestation in bank structures. For selecting them, an evaluation was conducted considering certain criteria. In Table 4.3.2.1-3 shows the details of the selection, in Table 4.3.2.1-4 you can find the Table with the selection criteria.

Evaluation criteria used for selection:

1. Species with adequate properties to grow and develop in the riverside (preferably native)
2. Possibility of growing in plant nurseries
3. Possibility of wood and fruit use
4. Demand of local population
5. Native species (preferably)

After making a field survey, a list of planted or indigenous species of each zone was firstly made. Then, a list of species whose plants would grow in seedbeds, according to interviews made to plant growers, was prepared.

Priority was given to the aptitude of local conditions and to plant production precedents, leaving as second priority its usefulness and demand or if they were native species or not. Table 4.3.2.1-4 shows the assessment criterion.

**Table 4.3.2.1-1 List of available production species**

Area	Provider	Production Place	Species produced usually	Species produced sometimes
Pisco	AGRORURAL	Lima	Pine, Molle, Eucalyptus, Huarango ( <i>Prosopis limensis</i> )	Cypress, Tara
	FOMECSAC	Lima	Tara, Molle, Huarango ( <i>Prosopis limensis</i> )	-
	AGRIMEX EIRL	Ica	Aliso, Algorrobo, Canya, Tamalix, Bamboo, Pine, Casuarina, Eucalyptus	-

(Source: Information gathered by the forestry seedlings producers)

**Table 4.3.2.1-2 List of verified tree species in the field (for riparian forestation)**

Location	Tree Species	Characteristics
Pisco	Huarango ( <i>Prosopis limensis</i> )	It has good track record in plantation/forestation, was taken as forestation species in the forestation plan of Cansus, Ica Region.
	Aromo	-

(Source: JICA study team)

**Table 4.3.2.1-3 Results of planting species selection (details)**

River Basin	Tree Species	Adequateness to evaluation items*						Remarks
		1	2	3	4	5	Total**	
Pisco	Aliso	C	B	A	C	A	--	Adequate for high elevation areas rather as
	Algarrobo	B	A	C	B	A	--	Similar to Huarango ( <i>Prosopis limensis</i> ), Prosopis is selected in the southern areas
	Canya (Cariso)	A	C	B	B	A	--	Grass
	Quinual	C	C	B	C	A	--	Adequate for high elevation areas rather as
	Colle	C	D	D	B	A	--	Adequate for high elevation areas rather as
	Tamalix	B	A	B	B	B	--	Its characteristics shows high adequateness in the Northern areas, but unknown in the southern areas
	Tara	D	A	A	B	A	-	Recently, fruit was found as effectiveness, becomes popular for plantation
	Bamboo	A	A	B	B	A	+	Unknown for forestation record
	Pine	B	D	B	B	B	-	Adequate for high elevation areas rather as
	Molle	B	A	B	B	A	+	It is said as its root grows in deep
	Casuarina	A	B	C	B	B	+	Adequate for high elevation areas rather as
	Eucalyptus	A	B	B	A	B	++	Adequate for high elevation areas rather as
	Huarango ( <i>Prosopis limensis</i> )	A	A	D	A	A	++	Its characteristics shows high adequateness in the area near to the sea or dry area

\* Evaluation criteria are shown above, \*\* ++: Selected, +: second, -: nominated but not so good,--: not be selected

(Source: JICA Study Team based on hearing from the seedling providers)

**Table 4.3.2.1-4 Selection criteria for planting species**

		Assessment Criterion				
		1	2	3	4	5
Assessment points	A	In situ testing (natural or reforested growth)	Major production	Possible use as wood or for fruit production	Water demand by the Users Committee, among others	Local specie
	B	Growth has not been checked in situ, however it adapts in the zone	Sporadic production	Possible use as wood or for fruit production	There is NO water demand by the Users Committee	No local specie
	C	None of the above	Possible reproduction but not usual	No use as wood nor fruit	—	—
	D	Unknown	Not produced	Unknown	—	—

(Source: JICA Study Team)

Table-4.3.2.1-5 shows a list of selected species applying these assessment criterion. © marks main species, ○ are those species that would be planted with a proportion of 30% to 50%. This proportion is considered to avoid irreversible damages such as plagues that can kill all the trees.

**Table 4.3.2.1-5 Selection of forest species**

Watershed	Forest species
Pisco	Eucalipto (☉), Huarango (○), Casuarina (○)

In the Pisco Watershed the main forestry specie is Eucalyptus. This specie adapts very well in this area, it adapts to the zone and has high demand by the Water User's Committees. Huarango (*Prosopis limensis*: is how this plant is known in the northern region of Peru, comes from another seed) is a native specie form the southern region of Peru. It is planted along the Panamericana Highway. Casuarina specie has been planted in this area to protect from wind and sand, moreover for the lands near farms.

### 3) Quantity of reforestation Plan

The afforestation plan has been selected as it is mentioned in the location and type of species plan. The afforestation will have 11 meters width.

Following Table 4.3.2.1-6 shows the construction estimating for the Forestry and Recovery of Vegetation Cover Plan for Pisco Watershed.



**Table 4.3.2.1-6 Amount of afforestation/vegetation recovery plan (riparian afforestation)**

No.	Side	Length (m)	Width (m)	Forestation Area (ha)	No. of Planting Stocks (No.)	Number of planting stocks for each Species (No.)			
						Eucalyptus	Hurango	Casuarina	Total
Pi-1	L	2,000	11	2.2	6,512	3,256	1,954	1,302	6,512
Pi-2				0.0	0	—	—	—	—
Pi-3	L	1,500	11	1.7	5,032	2,516	1,510	1,006	5,032
Pi-4	L	1,000	11	1.1	3,256	1,628	977	651	3,256
Pi-5				0.0	0	—	—	—	—
Pi-6	Whole	1,450	11	1.6	4,736	2,368	1,421	947	4,736
Total Pisco		5,950		6.6	19,536	9,768	5,862	3,906	19,536

(Source: JICA Study Team)

In Table 4.3.2.1-7 shows the percentage according to forest species and the explanation in each bank structure.

**Table 4.3.2.1-7 Ratios of number of planting stocks by species for each construction**

Serial No.	No.	Ratio of No. by Species			Remarks
		Eucalyptus	Casuarina	Huarango	
17	Pi-1	5	2	3	Eucalyptus is main species, and Hurango is sub. Huarango is the native species, it is expected that its characteristics has much adequateness than Casuarina. Then, Huarango is planted with prior than Casuarina
19	Pi-3	5	2	3	
20	Pi-4	5	2	3	
22	Pi-6	5	2	3	

(Source: JICA Study team)

#### 4) Plan location and execution

The location of the vegetation recovery area and afforestation plan for every bank structure is the same. It is worth mentioning that the vegetation recovery area and afforestation plan will take place once finished the construction of bank structures.

#### (4) Reforestation and vegetation recovery plan cost (short term)

##### 1) Unitary cost for the forestation plan and vegetation recovery

Direct costs for the forestation plan and vegetation recovery are formed by the following elements:

- Planting unitary cost (planting unitary cost + transportation)
- Labor cost
- Direct costs (tool costs: 5% labor)

##### a) Planting unitary cost

The supply of seedlings can be divided between private and agro-rural companies. The seedlings for afforestation upstream of the Pisco river watershed is acquired by AFRORURAL, in the case of plants for the river banks private companies will be the providers. The cost of plants for afforestation is detailed in Table 4.3.2.1-8. The price of different plants has been consulted in different private companies, just as with the means of transportation. (For more information see Appendix 7-Table 2)

**Table 4.3.2.1-8 Unit Price of seedling (for riparian forestation)**

River Basin	Species	Unit Price (Sol./seedling)
Pisco	Eucalyptus	1.4
	Huarango	1.8
	Casuarina	2.2

Note: Unit price of seedling = (Seedling price + transportation fee)

(Source: Hearing from suppliers)

**b) Labor cost**

Criteria to assign labor costs come from the information obtained from AGRORURAL and the Water users board, cost assigned by forestation of 40 seedling a day. So, 33.6 Soles/man-day is assigned for the workers foresting in river banks.

**c) Direct costs**

In direct costs the costs of the required tools are considered for the forestation project, instruments to dig holes for plants, plant transportation from its reception to the project area. Planting costs increase in 5%

**d) Work cost calculation for forestation and vegetation recovery in bank structures**

The work costs for the forestry plan and vegetation recovery in bank structures are indicated in Table 4.3.2.1-9. The total work cost is 1,784,023 soles.

To carry out the afforestation the contractor is needed to execute bank works. Just like the cost of construction works, 88% of direct costs is destined to indirect costs.

**Table 4.3.2.1-9 Cost Estimation of afforestation along river protection constructions (riparian afforestation)**

No.	No. of Construction	Cost of Afforestation (Sol)					
		Direct Cost				Indirect Cost	Total
		Seedlings	Planting works	Direct Expense	Sub Total		
17	Pi-1	10,940	5,470	274	16,684	14,715	31,399
18	Pi-2				0	0	0
19	Pi-3	8,454	4,227	211	12,892	11,371	24,263
20	Pi-4	5,470	2,735	137	8,342	7,358	15,700
21	Pi-5				0	0	0
22	Pi-6	596,736	298,368	14,918	910,022	802,639	1,712,661
Pisco River Basin		621,600	310,800	15,540	947,940	836,083	1,784,023

Source: JICA Study Team)

**(5) Implementation process planning**

The Process Plan of afforestation works in riverbanks is part of the river structure, thus the same will be considered for the Construction Plan of the River Structure. Afforestation works should generally start at the beginning of the rainy season or just before, and must end approximately one month before the season finishes. However, there is scarce rain in the coastal area; therefore there is no effect of dry and rainy seasons. For the sake of afforestation, it is most convenient is to take advantage of water rise,

but according to the Construction Schedule of the river structure there are no major afforestation issues in seasons where water level is low. The simple gravity irrigation system can be used to irrigate just planted plants during approximately the first 3 months until water level rises. This irrigation is performed using perforated horse which is a field technique actually carried out in Poechos dam area

#### **4.3.2.2 Sediment Control Plan**

##### **(1) Importance of the sediment control plan**

Below flood control issues in selected Watersheds are listed. Some of them relate to sediment control. In the present Project an overall flood control plan covering both the high and the low Watershed is prepared. The study for the preparation of the Sediment Control Plan comprised the whole Watershed.

- Water rise causes overflow and floods.
- Rivers have a steep slope of 1/30 to 1/300. The flow speed is high, as well as the sediment transport capacity.
- The accumulation of large quantities of dragged sediment and the consequent elevation of the river bed aggravate flood damages.
- There is a great quantity of sediment accumulated on the river bed forming a double sandbank. The water route and the spot of greater water impact are un-stable, causing route change and consequently, change of spot of greater water impact.
- Riverside is highly erodible, causing a decrease of adjacent farming lands, destruction of regional roads, etc., for what they should be duly protected.
- Big stones and rocks cause damages and destruction of water intakes.

##### **(2) Sediment control plan (structural measures)**

The sediment control plan for the present sediment movement pattern was analyzed. Table 4.3.2.2-1 details basic guidelines.

**Table 4.3.2.2-1 Basic guidelines of the sediment control plan**

Conditions	Typical year	Precipitations with 50-year return period
Sediment dragging	Bank erosion and river bed change	Bank erosion and river bed change Sediment flow from ravines
Measures	Erosion control → Bank protection  Control of riverbed variation → compaction of ground, bands (compaction of ground in the alluvial cone, bands)	Erosion control → bank protection Riverbed variation control → compaction of ground, bands (compaction of ground in the alluvial cone, bands) Sediment flow → protection of slopes, sediment control dams

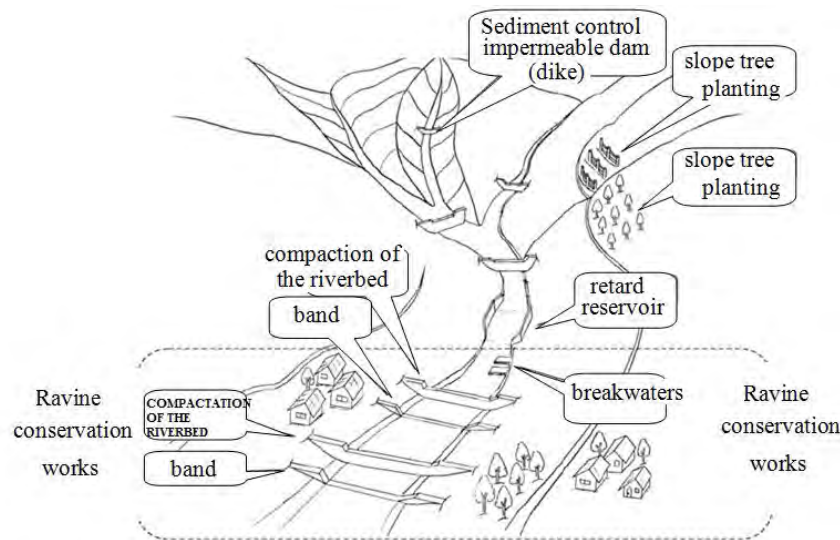

**Figure 4.3.2.2-1 Sediment control works**

1) Sediment control plan in the high watershed

The section 4.15 “Medium and long term Plan” 4.15.3 “Sediment Control Plan” details the sediment control plan covering the whole high Watershed. This plan will require an extremely long time with huge costs, what makes it quite not feasible. Therefore, it must be executed progressively within the medium and long term.

2) Sediment control plan in the alluvial fan

We observed that building sediment control dams covering the whole Watershed will demand huge costs. Therefore, the same calculation was done but reducing its scope to just the lower Watershed of the river. In this process, analysis results on riverbed variation were taken into consideration, also included in the present study.

i) Riverbed fluctuation analysis results

- The results of riverbed fluctuation analysis are as shown below. The average riverbed rising shows the average of rising in the objective section in future 50 years. The average bed height has been increasing in the river, so basically it is concluded that this is the general trend. The total variation volume of the bed and sediment transport is augmenting in the Pisco river.

Total volume of dragged sediment (in thousands of m <sup>3</sup> )	8,658
Annual average of dragged sediment (in thousands of m <sup>3</sup> )	173
Total volume of riverbed variation (in thousands of m <sup>3</sup> )	2,571
Annual average of variation of riverbed height (m)	0.2

- The most susceptible to the accumulation of sediment is Pisco river. This tendency coincides to the field hearing results and actual riverbed conditions.
- According to the results of the analysis of variation of the river bed, Pisco river is more susceptible to the accumulation of sediments carried, so sediment control works must be done in the alluvial fan. However the sediment disaster will happen suddenly and locally so that the

required river channel maintenance work will be examined for the river with monitoring of river bed sedimentation.

ii) Sediment control plan in the alluvial fan

To control sediments within the fan there are ravine conservation works, combined with sand reservoirs, riverbed consolidation, groin or a combination of these. These do not only work for sediment control, but as river structures.

Currently there are plans to build a retarding basin at the point of 34.5 km from river mouth in the Pisco River watershed, which also serves as a sediment retarding basin.

This structure is more economical and yield better cost benefit compared with structures designed to cover the entire watershed. It is much more profitable even when the cost of maintenance includes removal of stones and rocks.

Whereas the main objective of this project is in mitigating flood damage, the most effective option would be to control sediment in the alluvial fan.

It is already being planned to build river structure which also serves to control sediment in Pisco river, and its implementation would be the most effective.

### **4.3.3 Technical Assistance**

Based on the proposals on flood control measures, a component on technical assistance is proposed in order to strengthen risk management capabilities in the Program.

#### **(1) Component objective**

The component objective in the Program is the “Adequate capability of local population and professionals in risk management application to reduce flood damages in Watersheds”.

#### **(2) Target area**

The target area for the implementation of the present component is the Pisco watershed. In the execution stage, the implementation has to be coordinated with local authorities in the watershed. However, each authority has to execute those activities related with the characteristics of the watershed to carry out an adequate implementation.

#### **(3) Target population**

Target populations will represent irrigator associations and other community groups, provincial, district and local community governments and local people in the watershed, considering the limited capacity to receive beneficiaries of this component.

Participants are those with skills to widespread technical assistance contents of local populations in the watershed.

Besides, the participation of women has to be considered because currently only few ones participate

in technical assistance opportunities.

#### **(4) Activities**

In order to achieve the above purpose, the following 3 components of study and training is to be carried out.

#### Component 1: Knowledge on River Bank Protection Actions in consideration of Agriculture and Natural Environment

Course	a) River Bank Operation and Maintenance b) River Bank Plant Management c) Erosion Prevention and Mitigation Natural Resource Management
Objectives	a) In this project, local populations learn suitable technology to operate and give maintenance to constructions and works from prior projects. b) Local populations learn suitable technology on river bank plants and vegetation for flooding control purposes. c) Local populations learn suitable technology on erosion and natural resources for flooding control purposes.
Participants	a) Engineers and / or technicians from local Governments b-c) Engineers and / or technicians from local Governments and Water Users Associations, Community representatives
Times	a) 12 times in all (every six (6) hours) b) 12 times in all (every five (5) hours) c) 26 times in all (every three (3) hours)
Lecturers	a) Contractors of constructions and works, Engineers from MINAG and / or the Regional Government b-c) Engineers from MINAG and / or the Regional Government, College professors (From universities, institutes, NGOs, etc.)
Contents	a-1) Suitable operation and maintenance technology for constructions and works from prior projects a-2) Suitable operation and maintenance technology for constructions and works in this project b-1) River bank protection with the use of plants b-2) The importance of river bank vegetation in flooding control b-3) Types of river bank plants and their characteristics c-1) Evaluation of the erosion conditions c-2) Evaluation of natural resource conditions c-3) Erosion approach for flooding control c-4) Natural resource approach for flooding control c-5) Environmental consideration approach c-6) Use of water resources c-7) Alternatives for suitable farming crops

#### Component 2: Preparation of Community Disaster Management Plan for Flood Control

Course	a) Risk management Plan Formulation b) Detailed Risk management Plan Formulation
Objectives	a) Local populations gain knowledge and learn technology to prepare a flooding control plan b) Ditto
Participants	a-c) Engineers and / or technicians from local Governments and Water Users Associations, Community representatives

Times	a) 19 times in all (every four (4) hours) b) 34 times in all (every five (5) hours) c) 24 times in all (every five (5) hours)
Lecturers	a-c) Engineers from MINAG and / or the Regional Government, Community Development Expert, Facilitator (local participation )
Contents	a-1) Flooding control plan preparation manuals a-2) Current condition analyses for flooding control a-3) Community development alternatives by means of local participation a-4) Workshop for flooding control plan preparation b-1) Community activity planning in consideration of ecological zoning b-2) Risk management b-3) Resource management c-1) Preparation of community disaster management plan c-2) Joint activity with local governments, users' association, etc.

### Component 3: Basin Management for Anti – River Sedimentation Measures

Courses	a) Hillside Conservation Techniques b) Forest Seedling Production c) Forest Seedling Planting d) Forest Resource Management and Conservation
Objectives	a) Local populations learn suitable technology on hillside conservation for flooding control purposes b) Local populations learn suitable technology on forest seedling production c) Local populations learn suitable technology on forest seedling planting d) Local populations learn suitable technology on forest resource management and conservation
Participants	a-d) Engineers and / or technicians from local Governments and Water Users Associations, Community representatives and Local People
Times	a) 12 times in all (every five (5) hours) b-d) 40 times in all for three (3) “Courses on Basin Management for Anti - River Sedimentation Measures” (every five (5) hours)
Lecturers	a-d) Engineers from MINAG and / or the Regional Government, College professors (From universities, institutes, NGOs, etc.)
Contents	a-1) Soil characteristics and conservation on hillsides a-2) Hillside agroforestry system a-3) Animal herding system on hillsides a-4) Reforestation with traditional vegetation and plants a-5) Hillside conservation and alleviation alternatives b-1) A selection of plants that are suitable to the local characteristics b-2) Forest seedling production technology  b-3) Control carried out by the local population's involvement c-1) Candidate areas for forestation c-2) Forest plantation control technology c-3) Forest plantation soil technology c-4) Control carried out by the local population's involvement d-1) Forestation for flooding control purposes d-2) Forest plantation control technology d-3) Forest plantation output technology d-4) Control carried out by the local population's involvement

### (5) Direct cost and period

The direct cost for the above activities is as shown in the Table 4.3.3-1. The total cost for the objective basin is estimated as 144,050 soles, and the brake down of the unit cost is as shown in the Annex-12, Appendix No.5. And the period required for study and training is assumed to be as same as the construction period of 2 years.

**Table 4.3.3-1 Contents of technical assistance and direct cost**

Item	Activities	Unit	Unit price(soles)	No.of basin	Amount(soles)
1.0	<b>Knowledge on river bank protection action in consideration of agriculture and natural environment</b>				
1.1	Workshop on operation and maintenance of facilites	event	9,300	1	9,300
1.2	Workshop on river bank plantation management	event	9,300	1	9,300
	Prevention and mitigation for erosion	event	9,300	1	9,300
	Natural resources management	event	9,300	1	9,300
2.0	<b>Preparation of community disaster management plan for flood control</b>				
2.1	Workshop on risk management plan	event	8,370	1	8,370
2.2	Details of 2.1	event			
	Community activity planning in consideration of ecological zoning	event	12,200	1	12,200
	Risk management	event	12,200	1	12,200
	Resource management	event	12,200	1	12,200
	Preparation of community disaster management plan	event	12,200	1	12,200
2.3	Preliminary flood forecasting and warning	event			
	Risk management and early warning system	event	9,300	1	9,300
	Joint activity with local government, users' association, etc.	event	5,580	1	5,580
3.0	<b>Hillside management for river sedimentation prevention</b>				
3.1	Field works for hillside conservation technique	event	7,500	1	7,500
	Forest seedling productions	event	7,900	1	7,900
	Forest planatation setting up	event	7,900	1	7,900
	Forest resource management and conservation		7,900	1	7,900
3.2	Difusion of posters and leaflet		3,600	1	3,600
	<b>Total</b>				<b>144,050</b>

### (6)Implementation Plan

The Hydraulic Infrastructure General Direction (DGIH-MINAG) executes this component as the executing unity in cooperation with the Agriculture Regional Direction (DRA), the Board of Users and related Institutions. In order to execute the activities efficiently the following has to be considered:

- For the implementation of the present component, the DGIH-MINAG will coordinate actions with the Central Management Unit responsible for each Watershed, as well as with Regional Managements of Agriculture (DRA).



- For the Project administration and management, the DGIH-MINAG will coordinate actions with PSI-MINAG (Sub-sector Irrigation Program with extensive experience in similar projects).
- Considering there are some local governments that have initiated the preparation of a similar crisis management plan through the corresponding civil defense committee, under the advice of the National Institute of Civil Defense (INDECI) and local governments, the DGIH-MINAG must coordinate so that these plans be consistent with those existing in each Watershed.
- Training courses will be managed and administered by irrigator associations (particularly the unit of skills development and communications) with the support of local governments in each Watershed, to support timely development in each town.
- Experts in disaster management departments in each provincial government, ANA, AGRORURAL, INDECI, etc., as well as (international and local) consultants will be in charge of course instruction and facilitation.

## 4.4 Costs

### 4.4.1 Cost Estimate (at Private Prices)

#### (1) Project costs components

Project cost is composed of the following components:

##### 1) Infrastructure cost

###### i) Construction work cost

① Work direct costs (including plantation cost, environmental work cost, disaster prevention education/capacity development cost, infrastructure rehabilitation cost)

② Overhead cost = ① x 15%

③ Profit = ① x 10%

④ Work cost = ① + ② + ③

⑤ Tax = ④ x 18% (IGV)

⑥ Construction cost = ④ + ⑤

ii) Consultant cost (for structure, plantation, environmental work and disaster prevention education/capacity development)

⑦ Detailed design cost

⑧ Construction supervision cost

⑨ Consultant cost = ⑦ + ⑧

iii) Infrastructure cost = ⑥ + ⑨

##### 2) Land acquisition cost

##### 3) Management cost of implementation agency

4) Total project cost = 1) + 2) + 3)

#### (2) Direct cost

The direct costs were calculated by multiplying the unit prices with the work quantities. And the unit price is estimated for each work item based on the labor cost, material cost and equipment cost,

##### 1) Labor cost

The labor costs in Pisco river are as shown in the Table-4.4.1-1.

##### 2) Material cost

The major material costs in Pisco river are as shown in the Table-4.4.1-2.

##### 3) Equipment cost

The rental costs of equipment in Pisco river are as shown in the Table-4.4.1-3 .

4) Work quantities

The work quantity of each work item in each flood prevention facility is as shown in the Table-4.4.1-4. For further detail of work quantities refer to Annex-8 Plan and Design of Facility.

5) Unit price of work

Based on the above costs the unit price of each work is estimated, of which results in in Cañete river are as shown in the Table--4.4.1-5. For further detail refer to Annex-9 Construction Planning and Cost Estimate. Based on the work quantities and the unit price of work, the direct cost of construction work is calculated as shown in the Table-4.4.1-6

**(3) Infrastructure cost**

The infrastructure cost is as shown in the Table4.4.1-12, in which the breakdown of the detail design cost and construction supervision cost are as shown in the Table-4.4.1-7 and Table-4.4.1-8 respectively. The consultant cost was estimated based on the Terms of Reference attached to Annex-14 Implementation Program of Japanese Yen Loan Project as Appendix-1

**(4) Land acquisition and infrastructure rehabilitation**

The land acquisition coat and infrastructure rehabilitation cost are as shown in the Table-4.4.1-9 and the Table-4.4.1-10 respectively. For further detail refer to Annex-9 Construction Planning and Cost Estimate, 4. Compensation.

**(5) Management cost of implementation agency**

The management cost of implementation agency is as shown in the Table-4.4.1-11.

**(6) Total project cost**

The total project cost is calculated as shown in the Table-4.4.1-12.

**(7) Operation and maintenance cost**

The operation and maintenance cost after completion of the Project is estimated as shown in the Table-4.4.1-14 (refer to Annex-9 Constructoion Planning and Cost Estimation).

**Table-4.4.1-1 Unit labor cost (1)**

(SOLES)

Items	Skilled Labor	Common Labor	Assitant Labor	ChiefLabor **
Basic Wages (RB)	45.50	39.50	35.30	52.33
Bonus of Construction Dept. (BUC)	14.56	11.85	10.59	16.74
Social Benefit by Law Skilled Labor → 18.03% Common Labor → 17.83% AssitantLabor → .83%	53.70	46.54	41.59	61.76
Life Insurance ESSALUD - VIDA (S/. 5.00/month)	0.17	0.17	0.17	0.19
Work ware (2sets) -(2x90 / 303)	0.60	0.60	0.60	0.69
Transpotation Wages	7.20	7.20	7.20	8.28
<b>Daily Wages (8 hours)</b>	<b>121.73</b>	<b>105.86</b>	<b>95.45</b>	<b>139.99</b>
<b>Hourly Wages</b>	<b>15.22</b>	<b>13.23</b>	<b>11.93</b>	<b>17.50</b>

\*\*) 15% increase of hourly wages of skilled labor

source: REVISTA DE LA CAMARA PERUANA DE LA CONSTRUCCION

**Table-4.4.1-1 Unit labor cost (2)**

	Description	Unit	Unit Price (soles)
1	Rock Driller Assistant	h	15.22
2	Surveyor	h	17.50
3	Chief Labor	h	17.50
4	Skilled Labor	h	15.22
5	Common Labor	h	13.23
6	AssitantLabor	h	11.93
7	Blasting specialist	h	17.50
8	Rock Driller	h	17.50

**Table-4.4.1-2 Unit price of main material**

	Material	Unit	Unit Price (soles)
1	Nail for wood C/C 3"	KG	3.69
2	Nail for calamina 1 1/2"	KG	6.15
3	Dynamite 65%	KG	7.29
4	Plus bit	No.	36.91
5	Drill hammer 7/8" X 3in	No.	295.32
6	Drill hammer 7/8" X 5in	No.	319.93
7	Plaster (28kg/sack)	sack	6.56
8	Train of powder	M	0.33
9	Primer	M	0.62
10	Installation of construction notice board	set	820.32
11	Wood 2" x 3" x 2.4M	No.	6.56
12	Control panel 4MM	sheet	30.16

13	Wooden pile	No.	1.64
14	Enamel paint	gallon	30.35
15	Galvanized roof sheet 1.83 x 0.90 x 0.3 mm	sheet	9.02
16	Anfo explosive	sack	57.75
17	Scale	No.	41.02
18	Fuel DIESEL N° 02	gallon	12.3
19	GEOTEXTILE	M2	5.2

**Table-4.4.1-3 Unit cost of main heavy equipment**

	Equipment	Unit	Unit Price(soles)
1	Compressor 335-375 PCM, 93 HP	h	98.44
2	Braker21 KG	h	20.51
3	Semi-trailer 6x4, 260-300 HP	L.S	10504.1
4	Staff&Pole	h	1.64
5	Water supply car 4 x 2(ASF) 178-210HP 2,000G	h	106.64
6	Theodlite	h	6.56
7	Tractors/O HP / D155X5	h	270.71
8	Back-hoe 158 HP / PC220	h	127.15
9	Dump truck 6X4 / 318 - 395 HP / 10 - 12 M3	h	110.74
10	Total station	h	13.14
11	Bulldozer 160-195 HP 3.5 YD3	h	159.66

**Table-4.4.1-4 Work quantities**

	Work	Unit	Quantities
			PISCO
1.0	<b>Temporary work</b>		
1.1	Field office	M2	530
1.2	Construction notice board	L.S.	6
1.3	Temporary road	KM	13
1.4	Equipment transportation	L.S.	1
2.0	<b>Preparatory work 準備工事</b>		
2.1	Coordinates and leveling survey	M	16,020
2.2	Supervision of survey	M	16,020
2.3	Equipment transportation	L.S.	5
2.4	Removal of existing concrete	M3	0
2.5	Riverbed excavation	M3	
2.6	Soil disposal	M3	0
3.0	<b>Earth work</b>		
3.1	Riverbed excavation	M3	641,708
3.2	-ditto-	M3	203,197
3.3	Banking and compaction	M3	344,392
3.4	Ripper excavation	M3	200,055

3.5	Finishing slope of dike	M3	77,898
3.6	Soil disposal	M2	555,648
3.7	Riverbed excavation(for structure)	M3	
<b>4.0</b>	<b>Bank protection</b>		
4.1	Quarry of rock with blasting	M3	231,922
4.2	Accumulation of boulders	M3	231,922
4.3	Transportation of boulders	M3	231,922
4.4	Rivetment	M3	61,875
4.5	Installation of boulders	M3	170,047
4.6	Supply and installation of GEOTEXTILE sheet	M2	167,830
<b>5.0</b>	<b>Concrete work</b>		
5.1	Form work	M2	0
5.2	Concrete placing (FC=210 KG/CM2)	M3	0
<b>6.0</b>	<b>Gabion work</b>		
6.1	Accumulation of crushed stone (6~8インチ)	M3	0
6.2	Transportation of crushed stone	M3	0
6.3	Installation of mattress basket(5.0x1.0x1.0)m	No.	0
6.4	Putting crushed stone into basket(5.0x1.0x1.0)m	M3	0
6.5	Covering basket(5.0x1.0x1.0)m	No.	0

**Table-4.4.1-5 Estimate of work unit cost (example of Cañete river: Ca-1)**

Work	Temprary field office				Unit cost per : M2	85.73
Rate	20 M2/DIA (m2/day)					
Code	Discription	Unit	Party	Quantities	Unit price	Sub total
<b>Labor cost</b>						
470101	Chief Labor	h	0.10	0.04	17.50	0.70
470102	Skilled Labor	h	1.00	0.40	15.22	6.09
470103	Common Labor	h	1.00	0.40	13.23	5.29
470104	Assistant Labor	h	3.00	1.20	11.93	14.32
						<b>26.40</b>
<b>Material cost</b>						
020105	Nail for woodC/C 3"	KG		0.30	3.69	1.11
020112	Nail for calamina 1 1/2"	KG		0.22	6.15	1.35
430101	Wood 2" x 3" x 2.4M	No.		4.00	6.56	26.24
430201	Control panel 4MM	sheet		0.75	30.16	22.62
560101	Galvanized roof sheet 1.83 x 0.90 x 0.3 mm	sheet		0.80	9.02	7.22
						<b>58.54</b>
<b>Equipment cost</b>						
370101	Hand tool	%		3.00	26.40	0.79
						<b>0.79</b>

Work	Construction notice board				Unit cost per unit	922.20
Rate	3 (units/day)					
Code	Discription	Unit	Party	Quantities	Unit price	Sub total
<b>Labor cost</b>						
470103	Common Labor	h	1.00	2.67	13.23	35.28
470104	Assistant Labor	h	2.00	5.33	11.93	63.63
						<b>98.91</b>
<b>Material cost</b>						
399095	Transportation & installation of notice board	unit		1.00	820.32	820.32
						<b>820.32</b>
<b>Equipment cost</b>						
370101	Hand tool	%		3.00	98.91	2.97
						<b>2.97</b>

Work	Temporary road				Unit cost per KM	4,215.51
Rate	0.9 (Km/day)					
Code	Discription	Unit	Party	Quantities	Unit price	Sub total
<b>Labor cost</b>						
470101	Chief Labor	h	0.20	1.78	17.50	31.11
470103	Common Labor	h	1.00	8.89	13.23	117.60
470104	Assistant Labor	h	1.00	8.89	11.93	106.04

						254.75
<b>Material cost</b>						
910101	Fuel DIESEL Nº 02	gallon		106.49	12.30	1,309.83
						<b>1,309.83</b>
<b>Equipment cost</b>						
370101	Hand tool	%		3.00	254.75	7.64
490101	Water supply car 4 x 2(ASF) 178-210HP 2,000G	h	0.25	2.22	106.64	236.98
499401	Tractor S/O HP / D155X5	h	1.00	8.89	270.71	2,406.31
						<b>2,650.93</b>

---

<b>Work</b>	Coordinates & Levelling survey					
<b>Rate</b>	500 (m/day)			Unit cost per M	1.15	

---

Code	Discription	Unit	Party	Quantities	Unit price	Sub total
<b>Labor cost</b>						
470032	Surveyor	h	1.00	0.02	17.50	0.28
470104	Assistant Labor	h	3.00	0.05	11.93	0.57
						<b>0.85</b>
<b>Material cost</b>						
300201	Plaster (28kg/sack)	sack		0.01	6.56	0.03
540242	Enamel paint	gallon		0.00	30.35	0.03
						<b>0.06</b>
<b>Equipment cost</b>						
370101	Hand tool	%		3.00	0.85	0.03
499701	Total station	h	1.00	0.02	13.14	0.21
						<b>0.24</b>

---

<b>Work</b>	Supervision of survey					
<b>Rate</b>	300 (m/day)			Unit cost per M	1.79	

---

Code	Discription	Unit	Party	Quantities	Unit price	Sub total
<b>Labor cost</b>						
470032	Surveyor	h	1.00	0.03	17.50	0.47
470104	Assistant Labor	h	2.00	0.05	11.93	0.64
						<b>1.11</b>
<b>Material cost</b>						
300201	Plaster (28kg/sack)	sack		0.00	6.56	0.02
439901	Wooden peg	No.		0.20	1.64	0.33
900101	Scale	No.		0.00	41.02	0.08
						<b>0.43</b>
<b>Equipment cost</b>						
370101	Hand tool	%		3.00	1.11	0.03
375401	Staff& pole	h	1.00	0.03	1.64	0.04
491901	Theodlite	h	1.00	0.03	6.56	0.18
						<b>0.25</b>

---

<b>Work</b>	Transportation of heavy equipment					
-------------	-----------------------------------	--	--	--	--	--



*Preparatory study about the protection program for  
valleys and rural communities vulnerable to floods in Peru  
Final Report I-4 Main Report Project Report (Pisco River)*

Rate	1 (set/day)			Unit cost per set	10,504.11	
Code	Discription	Unit	Party	Quantities	Unit price	Sub total
<b>Equipment cost</b>						
320201	Semi-trailer 6x4, 260-300 HP	set	1.00	1.00	10,504.11	10,504.11
						<b>10,504.11</b>
<b>Work</b>	Riverbed excavation					
<b>Rate</b>	800 (m3/day)			Unit cost per M3	4.18	
Code	Discription	Unit	Party	Quantities	Unit price	Sub total
<b>Labor cost</b>						
470101	Chief Labor	h	0.20	0.00	17.50	0.04
470103	Common Labor	h	1.00	0.01	13.23	0.13
						<b>0.17</b>
<b>Material cost</b>						
910101	Fuel DIESEL N° 02	gallon		0.11	12.30	1.29
						<b>1.29</b>
<b>Equipment cost</b>						
370101	Hand tool	%		3.00	0.17	0.01
499401	Tractor S/O HP / D155X5	h	1.00	0.01	270.71	2.71
						<b>2.72</b>
<b>Work</b>	Transportation of back-fill soil					
<b>Rate</b>	1,100 (m3/day)			Unit cost per M3	6.05	
Code	Discription	Unit	Party	Quantities	Unit price	Sub total
<b>Labor cost</b>						
470101	Chief Labor	h	0.20	0.00	17.50	0.03
470103	Common Labor	h	1.00	0.01	13.23	0.10
						<b>0.13</b>
<b>Material cost</b>						
910101	Fuel DIESEL N° 02	gallon		0.14	12.30	1.77
						<b>1.77</b>
<b>Equipment cost</b>						
370101	Hand tool	%		3.00	0.13	0.00
499501	Hand tool	h	1.00	0.01	127.15	0.93
499601	Dump truck 6X4 / 318 - 395 HP / 10 - 12 M3	h	4.00	0.03	110.74	3.22
						<b>4.15</b>
<b>Work</b>	Banking & compaction					
<b>Rate</b>	900 (m3/day)			Unit cost per M3	3.71	
Code	Discription	Unit	Party	Quantities	Unit price	Sub total

*Preparatory study about the protection program for  
valleys and rural communities vulnerable to floods in Peru  
Final Report I-4 Main Report Project Report (Pisco River)*

<b>Labor cost</b>						
470101	Chief Labor	h	0.20	0.00	17.50	0.03
470103	Common Labor	h	1.00	0.01	13.23	0.12
						<b>0.15</b>
<b>Material cost</b>						
910101	Fuel DIESEL N° 02	gallon		0.09	12.30	1.15
						<b>1.15</b>
<b>Equipment cost</b>						
370101	Hand tool	%		3.00	0.15	0.00
499401	Tractor S/O HP / D155X5	h	1.00	0.01	270.71	2.41
						<b>2.41</b>

<b>Work</b>	Ripper excavation					
<b>Rate</b>	300 (m3/day)			Unit cost per M3	4.76	

Code	Discription	Unit	Party	Quantities	Unit price	Sub total
<b>Labor cost</b>						
470101	Chief Labor	h	0.20	0.01	17.50	0.09
470103	Common Labor	h	1.00	0.03	13.23	0.35
						<b>0.44</b>
<b>Material cost</b>						
910101	Fuel DIESEL N° 02	gallon		0.07	12.30	0.92
						<b>0.92</b>
<b>Equipment cost</b>						
370101	Hand tool	%		3.00	0.44	0.01
499501	Back-hoe 158 HP / PC220	h	1.00	0.03	127.15	3.39
						<b>3.40</b>

<b>Work</b>	Finishing slope of dike					
<b>Rate</b>	1,100 (m2/day)			Unit cost per M2	1.55	

Code	Discription	Unit	Party	Quantities	Unit price	Sub total
<b>Labor cost</b>						
470101	Chief Labor	h	0.20	0.00	17.50	0.03
470103	Common Labor	h	1.00	0.01	13.23	0.10
						<b>0.13</b>
<b>Material cost</b>						
910101	Fuel DIESEL N° 02	gallon		0.04	12.30	0.49
						<b>0.49</b>
<b>Equipment cost</b>						
370101	Hand tool	%		3.00	0.13	0.00
499501	Back-hoe 158 HP / PC220	h	1.00	0.01	127.15	0.93
						<b>0.93</b>

<b>Work</b>	Quarry of rock by blasting					
<b>Rate</b>	90 (m3/day)			Unit cost per M3	27.49	

Code	Discription	Unit	Party	Quantities	Unit price	Sub total
------	-------------	------	-------	------------	------------	-----------

*Preparatory study about the protection program for  
valleys and rural communities vulnerable to floods in Peru  
Final Report I-4 Main Report Project Report (Pisco River)*

<b>Labor cost</b>						
010101	Skilled Labor	h	2.00	0.18	15.22	2.71
470101	Chief Labor	h	0.20	0.02	17.50	0.31
470103	Common Labor	h	1.00	0.09	13.23	1.18
470104	Assistant Labor	h	1.00	0.09	11.93	1.06
470105	Blasting Specialist	h	1.00	0.09	17.50	1.56
980101	Rock Driller	h	2.00	0.18	17.50	3.11
						<b>9.93</b>
<b>Material cost</b>						
070101	Dynamite · 65%	KG		0.12	7.29	0.85
080101	Plus bit	No.		0.01	36.91	0.18
090101	Dril hammer7/8" X 3in	No.		0.00	295.32	0.35
100101	Drill hammer7/8" X 5in	No.		0.00	319.93	0.38
308601	Train of powder	M		0.89	0.33	0.29
308602	Primer	M		0.31	0.62	0.19
790101	Anfo explosive	sack		0.00	57.75	0.11
910101	Fuel DIESEL N° 02	gallon		0.20	12.30	2.51
						<b>4.86</b>
<b>Equipment cost</b>						
110101	Compressor 335-375 PCM, 93 HP	h	1.00	0.09	98.44	8.75
120101	Braker21 KG	h	2.00	0.18	20.51	3.65
370101	Hand tool	%		3.00	9.93	0.30
						<b>12.70</b>

<b>Work</b>	Accumulation of boulders					
<b>Rate</b>	100 (m3/day)			Unit cost per M3	15.65	

Code	Discription	Unit	Party	Quantities	Unit price	Sub total
<b>Labor cost</b>						
470101	Chief Labor	h	0.20	0.02	17.50	0.28
470103	Common Labor	h	1.00	0.08	13.23	1.06
						<b>1.34</b>
<b>Material cost</b>						
910101	Fuel DIESEL N° 02	gallon		0.33	12.30	4.10
						<b>4.10</b>
<b>Equipment cost</b>						
370101	Hand tool	%		3.00	1.34	0.04
499501	Back-hoe158 HP / PC220	h	1.00	0.08	127.15	10.17
						<b>10.21</b>

<b>Work</b>	Transportation of boulders					
<b>Rate</b>	220 (m3/day)			Unit cost per M3	48.17	

Code	Discription	Unit	Party	Quantities	Unit price	Sub total
<b>Labor cost</b>						
470101	Chief Labor	h	0.20	0.01	17.50	0.13
470103	Common Labor	h	1.00	0.04	13.23	0.48
470104	Assistant Labor	h	1.00	0.04	11.93	0.43

*Preparatory study about the protection program for  
valleys and rural communities vulnerable to floods in Peru  
Final Report I-4 Main Report Project Report (Pisco River)*

						1.04
<b>Material cost</b>						
910101	Fuel DIESEL N° 02	gallon		1.82	12.30	22.34
						22.34
<b>Equipment cost</b>						
370101	Hand tool	%		3.00	1.04	0.03
499501	Back-hoe158 HP / PC220	h	1.00	0.04	127.15	4.63
499601	Dump truck6X4 / 318 - 395 HP / 10 - 12 M3	h	5.00	0.18	110.74	20.13
						24.79

---

<b>Work</b>	Revetment		
<b>Rate</b>	150 (m3/day)	Unit cost per M3	14.92

---

Code	Discription	Unit	Party	Quantities	Unit price	Sub total
<b>Labor cost</b>						
470101	Chief Labor	h	0.20	0.01	17.50	0.19
470103	Common Labor	h	1.00	0.05	13.23	0.71
470104	Assistant Labor	h	6.00	0.32	11.93	3.82
						4.72
<b>Material cost</b>						
910101	Fuel DIESEL N° 02	gallon		0.27	12.30	3.28
						3.28
<b>Equipment cost</b>						
370101	Hand tool	%		3.00	4.72	0.14
499501	Back-hoe158 HP / PC220	h	1.00	0.05	127.15	6.78
						6.92

---

<b>Work</b>	Installation of boulders		
<b>Rate</b>	200 (m3/day)	Unit cost per M3	9.43

---

Code	Discription	Unit	Party	Quantities	Unit price	Sub total
<b>Labor cost</b>						
470101	Chief Labor	h	0.50	0.02	17.50	0.35
470103	Common Labor	h	1.00	0.04	13.23	0.53
470104		h	2.00	0.08	11.93	0.95
						1.83
<b>Material cost</b>						
910101	Fuel DIESEL N° 02	gallon		0.20	12.30	2.46
						2.46
<b>Equipment cost</b>						
370101	Hand tool	%		3.00	1.83	0.05
499501	Back-hoe158 HP / PC220	h	1.00	0.04	127.15	5.09
						5.14

---

<b>Work</b>	Supply & installation of GEOTEXTILE		
<b>Rate</b>	600 (m2/day)	Unit cost per M2	6.00

---

*Preparatory study about the protection program for  
valleys and rural communities vulnerable to floods in Peru  
Final Report I-4 Main Report Project Report (Pisco River)*

Code	Discription	Unit	Party	Quantities	Unit price	Sub total
<b>Labor cost</b>						
470101	Chief Labor	h	0.10	0.00	17.50	0.02
470103	Common Labor	h	1.00	0.01	13.23	0.18
470104		h	2.00	0.03	11.93	0.32
						<b>0.52</b>
<b>Material cost</b>						
940201	GEOTEXTILE	M2		1.05	5.20	5.46
						<b>5.46</b>
<b>Equipment cost</b>						
370101	Hand tool	%		3.00	0.52	0.02
						<b>0.02</b>

Table-4.4.1-6 Direct cost(private price and social price)

Basin		Direct Cost 直接工事費計											
		Name of Facility		River Structure		Plantation		Environmental Work		Disaster Prevention Education/ Capacity Development		Rehabilitation of Existing Facility	
		Private Price 民間価格 (PP)	Social Price 社会価格 (PS)	Private Price 民間価格 (PP)	Social Price 社会価格 (PS)	Private Price 民間価格 (PP)	Social Price 社会価格 (PS)	Private Price 民間価格 (PP)	Social Price 社会価格 (PS)	Private Price 民間価格 (PP)	Social Price 社会価格 (PS)	Private Price 民間価格 (PP)	Social Price 社会価格 (PS)
Pisco	PI-1	5.5K	4,679,372	16,684	13,169								
	PI-2	7.0K	4,319,384									4,168	3,447
	PI-3	13.5K	1,657,566	12,892	10,176								
	PI-4	20.5K	970,051	8,342	6,585								
	PI-5	26.5K	2,280,096										
	PI-6	34.5K	17,575,039	910,022	718,301								
<b>SUB TOTAL</b>		<b>38,149,427</b>	<b>31,481,508</b>	<b>947,940</b>	<b>748,231</b>	<b>772,915</b>	<b>655,013</b>	<b>144,050</b>	<b>124,788</b>	<b>4,168</b>	<b>3,447</b>		

**Table 4.4.1-7 Consultant cost for detail design stage(for 4 basins)**

	Item	Unit	Qty	Foreign Portion		Local Portion		Combined Total
				(Yen)		(soles)		(yen)
				Rate	Amount ('000)	Rate	Amount ('000)	Amount ('000)
A	Remuneration							
	1 Professional (A)	M/M	44	2,500,000	110,000	0	0	110,000
	2 Professional (B)	M/M	70	0	0	10,000	700	19,670
	3 Supporting Staffs	M/M	312	0	0	4,000	1,248	35,069
	Subtotal of A				110,000		1,948	164,739
B	Direct Cost							
	1 International Airfare		17	1,057,200	17,972	0	0	17,972
	2 Domestic Airfare (Duty Trip)		16		0	1,096	18	493
	3 Domestic Travel				0	0	0	0
	4 Accommodation Allowance (Pro A)	Month	44		0	5,480	241	6,775
	(Pro.B)	Month	70		0	2,740	192	5,390
	5 Per Diem for Duty Trip	Day	48		0	137	7	185
	6 Vehicle Rental	Month	0		0	5,480	0	0
	7 Office Rental	M/M	3		0	274	1	23
	8 International Communications	M/M	16		0	2,740	44	1,232
	9 Domestic Communications	M/M	16		0	1,370	22	616
	10 Office Supply	M/M	16		0	548	9	246
	11 Office Furniture and Equipment	L.M	1		0	54,800	55	1,540
	12 Report Preparation					0		
	1) Detailed Design	Volume	12		0	55	1	18
	2) Bid Documents	Volume	16		0	55	1	25
	3) Monthly and Quaterly Progress R	Volume	28		0	55	2	43
	4) Completion Report	Volume	5		0	55	0	8
	5) Other Notes and Documents	Volume	10		0	55	1	15
	13 Sub-Contracting Work					0	0	0
	Topographic Survey	Site	4		0	137,000	548	15,399
	Geotechnical Investigation	Site	4		0	82,200	329	9,239
	Environmental Monitoring	Site	4		0	68,500	274	7,699
	14 Technical & PCM	time	4		0	8,220	33	924
	Subtotal of B				17,972		1,775	67,843
	A+B				127,972		3,723	232,582
	A+B(soles)							8,276,940
	C: VAT(18%)(soles)							1,489,849
	Total A+B+C(soles)							9,766,778

**Table 4.4.1-8 Consultant cost for construction supervision stage (for 4 basins)**

Item	Unit	Qty	Foreign Portion		Local Portion		Combined	
			(Yen)		(soles)		Total	
			Rate	Amount ('000)	Rate	Amount ('000)	Amount ('000)	
<b>A Remuneration</b>								
1	Professional (A)	M/M	82	2,500,000	205,000	0	0	205,000
2	Professional (B)	M/M	135	0	0	10,000	1,350	37,935
3	Supporting Staffs	M/M	336	0	0	4,000	1,344	37,766
	Subtotal of A				205,000		2,694	280,701
<b>B Direct Cost</b>								
1	International Airfare		8	1,057,200	8,458	0	0	8,458
2	Domestic Airfare (Duty Trip)		29		0	1,096	32	893
3	Domestic Travel		0		0	0	0	0
4	Accommodation Allowance (Pro A)	Month	82		0	5,480	449	12,627
	(Pro.B)	Month	135		0	2,740	370	10,394
5	Per Diem for Duty Trip	Day	87		0	137	12	335
6	Vehicle Rental	Month	159		0	5,480	871	24,484
7	Office Rental	M/M	138		0	274	38	1,063
8	International Communications	M/M	29		0	2,740	79	2,233
9	Domestic Communications	M/M	29		0	1,370	40	1,116
10	Office Supply	M/M	29		0	548	16	447
11	Office Furniture and Equipment	L.M	0		0	54,800	0	0
12	Report Preparation					0		
	1) Detailed Design	Volume	0		0	55	0	0
	2) Bid Documents	Volume	0		0	55	0	0
	3) Monthly and Quaterly Progress R	Volume	29		0	55	2	45
	4) Completion Report	Volume	0		0	55	0	0
	5) Other Notes and Documents	Volume	0		0	55	0	0
13	Sub-Contracting Work		0			0	0	0
	Topographic Survey	Site	0		0	137,000	0	0
	Geotechnical Investigation	Site	0		0	82,200	0	0
	Environmental Monitoring	Site	0		0	68,500	0	0
14	Technical & PCM	time	6		0	8,220	49	1,386
	Subtotal of B				8,458		1,958	63,480
	A+B				213,458		4,652	344,181
	A+B (soles)							12,248,434
	C: VAT(18%)(soles)							2,204,718
	Total A+B+C(soles)							14,453,162

**Table 4.4.1-9 Land acquisition cost (soles)**

Basin	Rural Area A	Rural Area B	Total
Pisco	352,567	0	352,567

**Table 4.4.1-10 Rehabilitation cost of existing facility (direct cost)**

soles

Basin	Hydraulic Infrastructure			Road			Total
	Intake	Outlet	Channel	National	Departmental	Others	
Pisco	0	0	4,168	0	0	0	4,168



**Table-4.4.1-11 Administration cost of implementation agency (for 4 basins)**

	Item	Rate (US\$)	Rate (soles)	Period (month)	Total(soles)
<b>A</b>	<b>Program Management Unit (PMU)</b>				
1	Project Manager	6,000	16,320	36	587,520
2	Contact specialist	5,000	13,600	36	489,600
3	Secretary	1,200	3,264	36	117,504
4	Construction supervisor (Cañete river)	3,500	9,520	30	285,600
5	Construction supervisor (Chincha river)	3,500	9,520	30	285,600
6	Construction supervisor (Pisco river)	3,500	9,520	30	285,600
7	Construction supervisor (Majes-Camana river)	3,500	9,520	30	285,600
8	IT Engineer	2,750	7,480	36	269,280
9	Procurement specialist	3,300	8,976	36	323,136
10	Financial manager	3,300	8,976	36	323,136
11	Organization specialist (Adviser for irrigation committee)	3,300	8,976	36	323,136
12	Environmental assessment specialist	3,300	8,976	30	269,280
13	Archaeological specialist	3,300	8,976	30	269,280
14	Accountant	4,200	11,424	36	411,264
15	Driver ①	1,200	3,264	36	117,504
16	Driver ②	1,200	3,264	36	117,504
17	Driver ③	1,200	3,264	36	117,504
Subtotal					<b>4,878,048</b>
<b>B</b>	<b>Audit Cost</b>				
1	2012 year	25,000	68,000		68,000
2	2013 year	40,000	108,800		108,800
3	2014 year	40,000	108,800		108,800
4	2015 year	50,000	136,000		136,000
Subtotal					<b>421,600</b>
<b>C</b>	<b>Capacity Building</b>				
<b>C1</b>	<b>For JICA Project</b>				
1	Project manager	30	81.60	100	8,160
2	Contact specialist	30	81.60	100	8,160
3	Lawyer	30	81.60	100	8,160
4	Construction supervisor (Cañete river)	30	81.60	100	8,160

5	Construction supervisor (Chincha river)	30	81.60	100	8,160
6	Construction supervisor (Pisco river)	30	81.60	100	8,160
7	Construction supervisor (Majes-Camana river)	30	81.60	100	8,160
8	Miscellaneous procurement specialist	30	81.60	100	8,160
9	Accountant ①	30	81.60	100	8,160
10	Accountant ②	30	81.60	100	8,160
	Subtotal				<b>81,600</b>
<b>C2 Capacity Building</b>					
1	Project manager (management and finance)	10,000	27,200		27,200
2	Contract specialist(management and finance))	10,000	27,200		27,200
3	Lawyer	8,000	21,760		21,760
4	Construction supervisor (Cañete river)	8,000	21,760		21,760
5	Construction supervisor (Chincha river)	8,000	21,760		21,760
6	Construction supervisor (Pisco river)	8,000	21,760		21,760
7	Construction supervisor (Majes-Camana river)	8,000	21,760		21,760
8	IT engineer ①	8,000	21,760		21,760
9	IT engineer ②	8,000	21,760		21,760
10	Miscellaneous procurement specialist (contrac)	8,000	21,760		21,760
11	Accountant ① (accounting and finance)	8,000	21,760		21,760
12	Accountant ② (accounting and finance)	8,000	21,760		21,760
	Subtotal				<b>272,000</b>
<b>D Procurement of Equipment</b>					
1	Office funituturs	50,000	136,000	1	136,000
2	PC & copy maschine	35,000	95,200	1	95,200
3	Vhicle ① (4WD)	32,000	87,040	1	87,040
4	Vhicle ② (4WD)	32,000	87,040	1	87,040
5	Vhicle ③ (4WD)	32,000	87,040	1	87,040
6	Fuel & car maintenance	2,880	7,834	36	282,010
7	Office suply	1,000	2,720	36	97,920
	Subtotal				<b>872,250</b>
<b>E Monitoring of Project</b>					

*Preparatory study about the protection program for  
valleys and rural communities vulnerable to floods in Peru  
Final Report 1-4 Main Report Project Report (Pisco River)*

1	Administrator (project monitoring)	4,050	11,016	36	396,576
2	Engineer (project monitoring)	3,300	8,976	36	323,136
3	Consultant (organizing irrigation committee information & capacity building))	100,000	272,000	1	272,000
4	Consultant (preparation of completion report)	80,000	217,600	1	217,600
5	Air ticket	2,000	5,440	36	195,840
6	Per diem	6,000	16,320	36	587,520
	<b>1,992,672</b>				<b>1,992,672</b>
<b>Total</b>					<b>8,518,170</b>



Table-4.4.1-12 Total project cost (private price)

Name of Basin	Direct Cost					Indirect Cost					Consultant Cost			Infrastructure Cost Total Cost	Land Aquisition Cost	Cost Total for Basin	
	COMPONENT A				Direct Cost	Overhead	Profit	Work Cost	Tax(IGV)	Total Construction Cost	Detail Design Cost	Construction Supervision Cost	Total Construction Cost				
	Sutstructure Cost		Aforestation/ Reforestation	Environmental Cost													Disaster Prevention Education/ Capacity Development
	Flood Prevention Facility	Rehabilitation cost of Existing Structure															
(1)-1	(1)-2	(2)	(3)	(4)	(5)=(1)+(2)+(3)+(4)	(6) = 0.15 x (5)	(7) = 0.1 x (5)	(8) = (5)+(6)+(7)	(9) = 0.18 x (8)	(10) = (8)+(9)	(11)	(12)	(13)=(11)+(12)	(14)=(10)+(13)	(15)	(17)=(14)+(15)+(16)	
PISCO	39,047,316	4,168	50,051	772,915	144,050	40,018,500	6,002,775	4,001,850	50,023,125	9,004,162	59,027,287	2,889,022	4,275,259	7,164,281	66,191,569	352,567	66,544,136

Table-4.4.1-13 Total project cost (social price)

Name of Basin	Total Construction Cost (Private Price)	Factor of Correction	Total Construction Cost (Social Price)	Consultant Cost			Infrastructure Cost Total Cost	Land Acquisition Cost	Cost Total for Basin
				Detail Design Cost	Construction Supervision Cost	Total Construction Cost			
	(10) = (8)+(9)			(11)	(12)	(13)=(11)+(12)	(14) = (10)+(13)	(15)	(17) = (14)+(15)+(16)
PISCO	59,027,287	0.825	48,694,156	2,567,375	3,826,671	6,394,045	55,088,201	341,990	55,430,191

Table-4.4.1-14 Annual operation and maintenance cost

Basin	Cost(soles) (Private Price)	Ratio to Construction Cost (%)	Cost (soles) (Social Price)	Ratio to Construction Cost (%)
Pisco	382,856	0.7	325,427	0.7



#### 4.4.2 Cost Estimate (at social price)

The direct cost at social price is as shown in the previous Table-4.4.1-6. The consultant cost, land acquisition cost and administration cost of the implementation agency are converted from the private price to the social price. The total project cost at social price is calculated as shown in the Table - 4.4.1-13.

The social price is calculated by multiplying the private price (labor cost, material cost and equipment cost) with the standard conversion factor (SCF). SCF is the ratio of the private price in domestic and the social price calculated at the border with respect to all goods of the country's economy,

In this study, economic evaluation is calculated based on the Guidelines which are available in Peru (Guideline of the National Public Investment System (Directorial Resolution No. 003-2011-EF/68.01, Annex SNIP 10-V3.1)). Ministry of Economy and Finance is indicated SCF as shown in Table -4.4.2-1.

**Table-4.4.2-1 Standard conversion factor (SCF)**

<b>Correction Factors for Social Rates (Methodology MEF)</b>	
<b>DESCRIPCION</b>	<b>VALOR</b>
<b>·National Property Expenditures</b>	0.85
<b>·Imported Goods Expenditures</b>	0.92
<b>·Indirect Imported Goods Expenditures*</b>	
Tasa Ad. Valorem	0.12
General Sales Tax Rate	0.18
<b>·Currency correction factor</b>	1.08
<b>·Fuel costs</b>	0.66
<b>·Indirect costs (administrative and financial)</b>	0.85
Legal entity	0.85
Natural Person	0.91
<b>·Expenditures on skilled labor</b>	0.91
<b>·Expenditures on non skilled labor</b>	0.68
Lima Metropolitana urbano	0,86
Urban Coast Region	0,68
Rural Coast Region	0,57
Urban Sierra Region	0,60
Urban Sierra Region	0,41
Urban Forest Region	0,63
Rural Forest Region	0,49
<b>·Indirect taxes Manpower **</b>	
Fourth Category Rate for Non-Personal Services (10%)	0.91

As an example, the process of conversion from private price to social price for the direct cost of river structures is as shown in the Table-4.4.2-2. For other costs the process is shown in the Annex-10 Socio-economy and Economic Evaluation, Attachment-3.

**Table-4.4.2-2 Conversion process from private price to social price  
for direct cost of river structure**

(Sol)

Flood Prevention Facilities	Direct Cost. (Private Prices)						Direct Cost. (Social Prices)						
	Personal Expense		Tradable Goods			Total	Personal Expense		Tradable Goods			Total	
	with Qualifica- tion	without Qualifica- tion	Import Goods	Fuel	Non Trad- able Goods		with Qualifica- tion	without Qualifica- tion	Import Goods	Fuel	Non Trad- able Goods		
PI-1	532,122	142,608	2,809,374	1,963,581	255,576	5,703,661	484,231	96,974	2,384,624	1,295,964	317,579	4,699,372	
PI-2	446,908	133,894	2,687,862	1,769,603	213,227	5,251,094	46,322	91,048	2,472,833	1,157,538	81,243	4,3,9,384	
PI-3	197,681	51,553	1,050,123	594,756	98,786	1,992,899	1,9,890	3,5056	966,113	392,339	83,268	1,657,566	
PI-4	118,120	29,780	617,033	338,879	59,577	1,163,990	117,490	20,250	567,671	223,660	50,280	990,051	
PI-5	210,224	66,436	1,493,003	893,216	94,513	2,757,593	151,668	45,177	1,373,763	389,222	80,166	2,280,096	
PI-6	1,530,487	484,934	11,545,689	7,010,955	688,226	21,280,291	1,410,943	329,755	10,622,034	4,627,230	385,377	17,555,039	
					PISCO TOTAL	38,149,427						PISCO TOTAL	51,481,538



## 4.5 Social Assessment

### 4.5.1 Private Prices Costs

#### (1) Benefits

Flood control benefits are flood loss reduction that would be achieved by the implementation of the Project and is determined by the difference between the amount of loss with and without Project. Specifically, in order to determine the benefits that will be achieved by the works' construction. First, the flood amount per flood loss of the different return periods (between 2 to 50 years) is calculated; assuming that the flood control works have a useful life of 50 years. To finish, determine the annual average amount of the loss reduction from the loss amount of different return periods. [The Methodological Guideline for Protection and/or Flood Control Projects in agricultural or urban areas, 4.1.2p-105] establishes similar procedures. Above find the description of the procedures to determine concrete benefits.

- ① Determine the flood loss amount in the flood area by analyzing the magnitude of overflow that occurs without the Project for each return period (between 2 and 50 years).
- ② After, determine the amount of flood loss in the flood area by analyzing the magnitude of overflow that occurs when flood control priority works are built.
- ③ Determine the difference between ① and ②. Add the benefits of other works different than dikes (intakes, roads protection, etc.) in order to determine the total profits.

“Benefits of the Project” are considered as the sum of direct loss amount caused by overflow and indirect loss caused by the destruction of structures in vulnerable sections (farmland loss, interruption of traffic, etc.)

#### 1) Method of loss amount calculation

In this study, the amount of loss from direct and indirect damages to the variables listed in Table 4.5.1-1 was determined.

**Table 4.5.1-1 Flood loss amount calculation variables**

Loss	Variables	Description
(1) Direct	① Crops	<ul style="list-style-type: none"> <li>• Crops in flooding season The amount of crop loss by flooding is determined by multiplying the damage % regarding water depth and the number of days flooded</li> <li>• Agricultural land and infrastructure (channels, etc.)</li> <li>• Crop loss amount is determined by multiplying the damage % regarding water depth and the number of days flooded</li> </ul>
	② Hydraulic Works	<ul style="list-style-type: none"> <li>• Loss amount due to hydraulic structures destruction (intakes, channels, etc.).</li> </ul>
	③ Road Infrastructures	<ul style="list-style-type: none"> <li>• Flood damage related to road infrastructure is determined by the damage in transport sector</li> </ul>
	④ Housing	<ul style="list-style-type: none"> <li>• Residential and industrial buildings It is calculated applying the loss coefficient depending on the</li> </ul>

		<p>flood depth</p> <p>Housing: residential and industrial buildings; household goods: furniture, household appliances, clothing, vehicles, etc.</p> <p>Flood damages in housing, commercial buildings, assets and inventories (buildings and assets) is determined applying the loss coefficient according to the flood depth</p>
	⑤ Public Infrastructures	<ul style="list-style-type: none"> <li>• Determine the loss amount in roads, bridges, sewers, urban infrastructures, schools, churches and other public facilities</li> <li>• Determine the loss amount in public works by applying the correspondent coefficient to the general assets loss amount</li> </ul>
	⑥ Public Services	<ul style="list-style-type: none"> <li>• Electricity, gas, water, rail, telephone, etc.</li> </ul>
(2) Indirect	① Agriculture	<ul style="list-style-type: none"> <li>• Estimate the loss caused by irrigation water interruption due to the damage of hydraulic structures</li> <li>• Determine the construction and repair costs of hydraulic structures such as direct year costs</li> </ul>
	② Traffic Interruption	<ul style="list-style-type: none"> <li>• Estimate the loss lead by traffic interruption due to damages on flooded roads</li> <li>• Determine road's repair and construction costs as damage direct cost</li> </ul>

a) Direct loss

Direct loss is determined by multiplying the damage coefficient according to the inundation depth as the asset value.

b) Indirect Loss

- Indirect loss is determined taking into account the impact of intakes and damaged
- Roads. Below, calculation procedures are described.

i) Intake damage

The loss amount due to intake damage is calculated by adding the direct loss (intake's rehabilitation and construction) and the indirect loss amount (harvest loss due to the interruption of irrigation water supply)

① Calculating the infrastructure cost

- Works Cost = construction cost per water unit taken × size (flow, work length)
- Unit cost of the work: for intakes and channels, it is required to gather information on the water intake volume of the existing work and the works' execution cost (construction or repair). The unit cost is calculated by analyzing the correlation among them both. It was estimated that the work will be completely destroyed by the flow with a return period of 10 years.

② Crop loss

- Annual earnings are determined according to the crops grown in the correspondent
- irrigation district

Annual Profit = (crops selling - cost) × frequency of annual harvest

Crop Sale = planted area (ha) x yield (kg/ha) × transaction unit price

Cost = unit cost (s/ha) × planted area (ha)

ii) Road infrastructure damage

Determine the loss due to traffic interruption

Amount of loss = direct loss + indirect loss

Direct loss: road construction cost (construction, rehabilitation)

Indirect Loss: opportunity loss cost due to road damage (vehicle depreciation + staff expenses loss)

Then, a 5 days period takes place of non-traffic ability (usually in Peru it takes five days to complete the rehabilitation of a temporary road)

2) Loss estimated amount according to different return periods

The loss amount according to the different return periods is calculated as shown in the Table 4.5.1-2. For further detail refer to I-7 Data Book.

**Table 4.5.1-2 Estimated loss by flooding at private price (Pisco river)**

(1,000 soles)

Description	T=50 years	
	Without Project	With Project
Agricultural Product	25,230	5,349
Hydraulic Structure	12,757	1,442
Road	11,560	1,689
Housing	16,945	478
Public Facility	4,548	129
Public Service	10,470	22
<b>TOTAL</b>	<b>81,510</b>	<b>9,108</b>

In the Table 4.5.1-3, the estimated amounts of loss by flooding of different return periods with or without Project is shown.

**Table 4.5.1-3 Loss estimated value (at private prices)**

(10<sup>3</sup> Soles)

Case	t	Private Price
		Pisco
Without Project	2	16,668
	5	23,343
	10	50,239
	25	59,936
	50	81,510
	Total	231,698
With Project	2	221
	5	302
	10	2,756
	25	6,595
	50	9,108
	Total	18,982

The estimated loss by flood without project in return period of 50- year will be 81.5 million soles in Pisco.

3) Loss amount (annual average) expected to be reduced by the Project

The average annual damage reduction amount is calculated by multiplying the annual damage reduction corresponding to probable flood with occurrence probability and by accumulating the annual damage reduction of each probable flood.

The calculation method is as shown in the Table 4.5.1-4.

**Table 4.5.1-4 Calculation method of annual average of loss reduction amount**

Probabilities	Loss Amount			Average path's loss	Paths' Probabilities	Loss reduction annual average amount
	Without Project	With Project	Loss Reduction			
1/1			$D_0 = 0$			
1/2	$L_1$	$L_2$	$D_1 = L_1 - L_2$	$(D_0 + D_1)/2$	$1 - (1/2) = 0,500$	$d_1 = (D_0 + D_1)/2 \times 0,67$
1/5	$L_3$	$L_4$	$D_2 = L_3 - L_4$	$(D_1 + D_2)/2$	$(1/2) - (1/5) = 0,300$	$d_2 = (D_1 + D_2)/2 \times 0,300$
1/10	$L_5$	$L_6$	$D_3 = L_5 - L_6$	$(D_2 + D_3)/2$	$(1/5) - (1/10) = 0,100$	$d_3 = (D_2 + D_3)/2 \times 0,100$
1/20	$L_7$	$L_8$	$D_4 = L_7 - L_8$	$(D_3 + D_4)/2$	$(1/10) - (1/20) = 0,050$	$d_4 = (D_3 + D_4)/2 \times 0,050$
1/30	$L_9$	$L_{10}$	$D_5 = L_9 - L_{10}$	$(D_4 + D_5)/2$	$(1/20) - (1/30) = 0,017$	$d_5 = (D_4 + D_5)/2 \times 0,017$
1/50	$L_{11}$	$L_{12}$	$D_6 = L_{11} - L_{12}$	$(D_5 + D_6)/2$	$(1/30) - (1/50) = 0,013$	$d_6 = (D_5 + D_6)/2 \times 0,013$
1/100	$L_{13}$	$L_{14}$	$D_7 = L_{13} - L_{14}$	$(D_6 + D_7)/2$	$(1/50) - (1/100) = 0,010$	$d_7 = (D_6 + D_7)/2 \times 0,010$
Foreseen average annual amount of loss reduction				$d_1 + d_2 + d_3 + d_4 + d_5 + d_6 + d_7$		

4) Results of the loss amount calculation (annual average)

In Table 4.5.1-5 the results of the loss amount calculation are shown (annual average), which are expected to be reduced by implementing each river's Project.

**Table 4.5.1-5 Annual average of loss reduction amount (private prices)**

Basin	Return Period	Probability	Total Damage (10 <sup>6</sup> Soles)			Average Damage ④	Section Probability ⑤	Annual Average Damage ⑥=④×⑤	Accumulation of Annual Average Damage
			Without Project ①	With Project ②	Damage Reduction ③=①-②				
CHINCHA	1	1.000	0	0	0		0	0	
	2	0.500	15.262	449	14.813	7.406	0.500	3.703	3.703
	5	0.200	39.210	3.005	36.205	25.509	0.300	7.653	11.356
	10	0.100	55.372	4.309	51.063	43.634	0.100	4.363	15.719
	25	0.040	77.797	14.282	63.515	57.289	0.060	3.437	19.156
	50	0.020	103.947	29.945	74.002	68.758	0.020	1.375	20.532

**(2) Social assessment**

1) Assessment's objective and indicators

The social assessment's objective in this Study is to evaluate investment's efficiency in structural measures using the analysis method of cost-benefit (C/B) from the national economy point of view.

For this, economic assessment indicators were determined (relation C/B, Net Present Value - NPV and IRR). The internal return rate (IRR) is an indicator that denotes the efficiency of the project's investment. It is the discount rate to match the current value of the project's generated cost regarding the benefit's current value. It is the discount rate necessary so the Net Present Value (NPV) equals zero and the relation C/B equals one. It also indicates the percentage of benefits generated by such investment. The internal return rate used in the economic assessment is called "economical internal return rate (EIRR)". The market price is turned into the economical price (costs at social prices) eliminating the impact of market distortion.

The IRR, C/B relation and NPV are determined applying mathematical expressions shown in the Table below. When IRR is greater than the social discount rate, the relation C/B is greater than one and NPV is greater than zero, it is considered that the project is efficient from the national economic growth point of view.

**Table 4.5.1-6 Evaluation indicator of economic benefit and its characteristics**

Indicators	Definition	Characteristics
Net Present Value (NPV)	$NPV = \sum_{i=1}^n \frac{B_i}{(1+r)^i} - \sum_{i=1}^n \frac{C_i}{(1+r)^i}$	<ul style="list-style-type: none"> <li>- Allows comparing net benefit magnitude performed by the project</li> <li>- It varies depending on the social discount rate</li> </ul>
Cost-Benefit Relation (C/B)	$B/C = \sum_{i=1}^n \frac{B_i}{(1+r)^i} / \sum_{i=1}^n \frac{C_i}{(1+r)^i}$	<ul style="list-style-type: none"> <li>- Allows comparing the investment efficiency by the magnitude of benefit per investment unit</li> <li>- Varies depending on the social discount rate</li> </ul>
Economical Internal Return Rate (EIRR)	$\sum_{i=1}^n \frac{B_i}{(1+r)^i} = \sum_{i=1}^n \frac{C_i}{(1+r)^i}$	<ul style="list-style-type: none"> <li>- Allows knowing the investment efficiency comparing it to the social discount rate</li> <li>- Does not vary depending on the social discount rate</li> </ul>
Where Bi: benefit per "i" year / Ci: cost per "i" year / r: social discount rate (11 %) / n: years of assessment		

## 2) Assumptions

Next, find the assumptions of every indicator used from the economical assessment

### i) Assessment Period

The assessment period is set between 2013 and 2027 (15 years after construction works started).

This Project implementing schedule is the following:

2012: Detailed Design

2013-2014: Construction

2013-2027: Assessment Period

The assessment period is 15 years which is same period as the adopted period in the Perfil program report of this Project. The SNIP regulation stipulates that the assessment period is to be 10 years basically, however the period can be changed if the project formulation agency (DGIH in this Project) admits that it is necessary. DGIH adopted 15 years in the Perfil program report and which was approved by OPI and DGPI (March 19, 2010). In JICA's development project the evaluation period of 50 years is generally adopted, so that JICA Study Team inquired DGIH and

OPI on this matter, they directed to adopt 15 years. In case of 50 years, the evaluation will be made in the Annex-14, Implementation Program of Japan Yen Loans Project.

ii) Standard Conversion Factor (SCF)

The standard conversion factor (SCF) is the relationship between socioeconomic prices established along the border and national private prices of all goods in a country's economy. It is used to convert goods and services prices purchased in the local market at affordable prices. SCF is stipulated by MEF as shown in the previous Table 4.4.2-1.

iii) Other preliminary conditions

Price level: 2011

Social discount rate: 10% (according to SNIP regulation)

Annual maintenance cost: estimated in the Table 4.4.1-14

3) Cost-benefit relation analysis

A comparison of the total cost and total benefit of flood control works converted to present values applying the social discount rate was performed. In this case, the total cost is the addition of construction, operation and maintenance costs. The total benefit is the loss amount that was reduced due to the works. For this, a base year was established for the conversion into the current value at the moment of the assessment, and the assessment period was set for the next 15 years from the beginning of the Project. The total cost was determined adding-up the construction, operation and maintenance costs of the works converted into present values; and the total benefit adding-up the annual average loss amount turned into current values.

In Table 4.5.1-7 results of calculations C/B, NPV and IRR to private prices is shown.

**Table 4.5.1-7 Social assessment (C/B, NPV, IRR) (at private prices)**

流域 Basin	年平均被害軽減額 Average Annual Damage Reduction Amount	評価期間被害 軽減額(15年) Damage Reduction Amount in Evaluation Period(15years)	事業費 Project Cost	維持管理費 Operation & Maintenance Cost	B/C Benefit and Cost Ratio	Net Present Value (NPV) Valor Actual Neto (VAN)	Internal Rate of Return (IRR) Tasa Interna de Retorno (TIR)
Pisco	231,968,634	104,752,437	66,544,136	4,977,123	1.74	44,377,936	21%

The social evaluation at private price level is calculated as shown in the Table 4.5.1-8 for Pisco river.

Table-4.5.1-8 Social evaluation at private prices (Pisco river)

Period	Year	Cost										Savings Value	Cost/ Benefit (GBR) Z (Z=Σ(③-④))	Net Present Value (NPV) (NPV=Σ(②-③)) (VAB-VAC)	Internal Rate of Return (IRR) (IRR=(②-③)/(①-②)) (IRR)						
		Benefit		Construction Cost		Operation & Maintenance Cost		Rehabilitation Cost		Environmental Cost						Disaster Prevention Education/ Capacity Building Cost		Land Acquisition Cost		Information Agency Administration Cost	
		Expected Annual Damage Reduction (①)	Benefit (Present Value PV) (②)	Cost (③)	Present Value (PV) (④)	Cost (⑤-1)	Present Value (PV) (⑥-2)	Cost (⑤-2)	Present Value (PV) (⑥-2)	Cost (⑤-3)	Present Value (PV) (⑥-3)	Cost (⑤-4)	Present Value (PV) (⑥-4)	Cost (⑤-5)	Present Value (PV) (⑥-5)	Cost (⑤-6)	Present Value (PV) (⑥-6)	Total Cost (C) Value (⑦)	Total Present Value (⑧)		
Investment - Construction Period	0	2010	2,880,022	2,880,022	2,880,022	0	0	0	0	0	0	0	0	0	0	0	2,880,022	2,880,022	-2,880,022	-2,880,022	
	1	2013	281,382,276	25,280,201	25,280,201	281,382,276	691,100	652,552	0	0	0	0	0	179,284	179,284	2,112,629	1,942,298	31,827,257	28,984,142	-28,984,142	-31,827,257
	2	2014	281,382,276	22,542,474	22,542,474	281,382,276	691,100	577,774	0	0	0	0	0	179,284	179,284	1,965,658	1,765,658	31,827,257	28,984,142	-28,984,142	-31,827,257
	3	2015	17,842,411	1,692,210	1,692,210	17,842,411	382,256	352,256	0	0	0	0	0	0	0	0	0	382,256	352,256	131,110	1,760,852
	4	2016	17,842,411	1,469,210	1,469,210	17,842,411	382,256	352,256	0	0	0	0	0	0	0	0	0	382,256	352,256	27,294	1,760,852
	5	2017	17,842,411	1,107,558	1,107,558	17,842,411	382,256	352,256	0	0	0	0	0	0	0	0	0	382,256	352,256	10,841,326	1,760,852
	6	2018	17,842,411	807,232	807,232	17,842,411	382,256	352,256	0	0	0	0	0	0	0	0	0	382,256	352,256	8,962,14	1,760,852
	7	2019	17,842,411	595,651	595,651	17,842,411	382,256	352,256	0	0	0	0	0	0	0	0	0	382,256	352,256	6,901,195	1,760,852
	8	2020	17,842,411	432,423	432,423	17,842,411	382,256	352,256	0	0	0	0	0	0	0	0	0	382,256	352,256	5,143,526	1,760,852
	9	2021	17,842,411	312,256	312,256	17,842,411	382,256	352,256	0	0	0	0	0	0	0	0	0	382,256	352,256	3,732,732	1,760,852
	10	2022	17,842,411	227,122	227,122	17,842,411	382,256	352,256	0	0	0	0	0	0	0	0	0	382,256	352,256	2,611,12	1,760,852
	11	2023	17,842,411	164,122	164,122	17,842,411	382,256	352,256	0	0	0	0	0	0	0	0	0	382,256	352,256	1,819,24	1,760,852
	12	2024	17,842,411	119,000	119,000	17,842,411	382,256	352,256	0	0	0	0	0	0	0	0	0	382,256	352,256	1,300,00	1,760,852
	13	2025	17,842,411	85,566	85,566	17,842,411	382,256	352,256	0	0	0	0	0	0	0	0	0	382,256	352,256	958,376	1,760,852
	14	2026	17,842,411	62,256	62,256	17,842,411	382,256	352,256	0	0	0	0	0	0	0	0	0	382,256	352,256	693,736	1,760,852
15	2027	17,842,411	45,122	45,122	17,842,411	382,256	352,256	0	0	0	0	0	0	0	0	0	382,256	352,256	503,736	1,760,852	
Total			231,968,835	104,754,837	51,865,574	4,977,126	2,242,972	1,213,324	699,700	212,474	184,376	352,256	305,947	4,273,258	3,709,205	71,921,644	60,344,000	1,74	44,377,930	21,76	

Table-4.5.1-9 Social evaluation at social prices (Pisco river)

Period	Year	Cost										Savings Value	Cost/ Benefit (GBR) Z (Z=Σ(③-④))	Net Present Value (NPV) (NPV=Σ(②-③)) (VAB-VAC)	Internal Rate of Return (IRR) (IRR=(②-③)/(①-②)) (IRR)							
		Benefit		Construction Cost		Operation & Maintenance Cost		Rehabilitation Cost		Environmental Cost						Disaster Prevention Education/ Capacity Building Cost		Land Acquisition Cost		Information Agency Administration Cost		Total Cost (C)
		Expected Annual Damage Reduction (①)	Benefit (Present Value PV) (②)	Cost (③)	Present Value (PV) (④)	Cost (⑤-1)	Present Value (PV) (⑥-2)	Cost (⑤-2)	Present Value (PV) (⑥-2)	Cost (⑤-3)	Present Value (PV) (⑥-3)	Cost (⑤-4)	Present Value (PV) (⑥-4)	Cost (⑤-5)	Present Value (PV) (⑥-5)	Cost (⑤-6)	Present Value (PV) (⑥-6)	Total Cost (C) Value (⑦)	Total Present Value (⑧)			
Investment - Construction Period	0	2010	2,880,022	2,880,022	2,880,022	0	0	0	0	0	0	0	0	0	0	0	0	2,880,022	2,880,022	-2,880,022	-2,880,022	
	1	2013	281,382,276	21,092,231	21,092,231	281,382,276	591,820	901,655	0	0	0	0	0	0	0	0	0	191,326	1,739,114	26,431,427	240,531,76	
	2	2014	281,382,276	18,192,210	18,192,210	281,382,276	591,820	459,920	0	0	0	0	0	0	0	0	0	191,326	1,381,226	26,431,427	218,411,8	
	3	2015	18,296,831	1,348,000	1,348,000	18,296,831	324,427	324,427	0	0	0	0	0	0	0	0	0	0	324,427	324,427	1,348,000	2,032,427
	4	2016	18,296,831	1,249,001	1,249,001	18,296,831	324,427	324,427	0	0	0	0	0	0	0	0	0	0	324,427	324,427	1,249,001	1,808,001
	5	2017	18,296,831	1,136,752	1,136,752	18,296,831	324,427	324,427	0	0	0	0	0	0	0	0	0	0	324,427	324,427	1,136,752	1,571,752
	6	2018	18,296,831	839,899	839,899	18,296,831	324,427	324,427	0	0	0	0	0	0	0	0	0	0	324,427	324,427	839,899	1,331,899
	7	2019	18,296,831	609,207	609,207	18,296,831	324,427	324,427	0	0	0	0	0	0	0	0	0	0	324,427	324,427	609,207	1,122,699
	8	2020	18,296,831	442,256	442,256	18,296,831	324,427	324,427	0	0	0	0	0	0	0	0	0	0	324,427	324,427	442,256	980,442
	9	2021	18,296,831	324,427	324,427	18,296,831	324,427	324,427	0	0	0	0	0	0	0	0	0	0	324,427	324,427	324,427	756,074
	10	2022	18,296,831	231,122	231,122	18,296,831	324,427	324,427	0	0	0	0	0	0	0	0	0	0	324,427	324,427	231,122	524,952
	11	2023	18,296,831	164,122	164,122	18,296,831	324,427	324,427	0	0	0	0	0	0	0	0	0	0	324,427	324,427	164,122	360,830
	12	2024	18,296,831	119,000	119,000	18,296,831	324,427	324,427	0	0	0	0	0	0	0	0	0	0	324,427	324,427	119,000	241,830
	13	2025	18,296,831	85,566	85,566	18,296,831	324,427	324,427	0	0	0	0	0	0	0	0	0	0	324,427	324,427	85,566	156,264
	14	2026	18,296,831	62,256	62,256	18,296,831	324,427	324,427	0	0	0	0	0	0	0	0	0	0	324,427	324,427	62,256	94,008
15	2027	18,296,831	45,122	45,122	18,296,831	324,427	324,427	0	0	0	0	0	0	0	0	0	0	324,427	324,427	45,122	48,886	
Total			237,897,001	107,429,324	49,077,857	42,896,416	4,250,511	1,310,432	1,103,690	977,704	896,144	838,389	382,610	341,900	320,089	382,610	59,350,325	2,13	5,078,400	28,8		

## 4.5.2 Social Prices Costs

### (1) Benefits

1) Estimated loss amount according to different return periods

The loss amount according to the different return periods is calculated as shown in the Table 4.5.2-1.

For further detail refer to I-7 Data Book.

**Table 4.5.2-1 Estimated loss by flooding at social price (Pisco river)**

1,000 soles

Description	T=50 years	
	Without Project	With Project
Agricultural Product	41,768	8,585
Hydraulic Structure	10,550	1,192
Road	9,133	1,334
Housing	14,352	404
Public Facility	3,853	109
Public Service	8,245	18
<b>TOTAL</b>	<b>87,899</b>	<b>11,643</b>

In the Table 4.5.2-2, the estimated amounts of loss by flooding of different return periods with or without Project are shown.

**Table 4.5.2-2 Loss estimated value (at social prices)**

(10<sup>3</sup> Soles)

Case	t	Social Price
		Pisco
Without Project	2	17,099
	5	22,817
	10	54,702
	25	64,250
	50	87,899
	Total	246,768
With Project	2	310
	5	433
	10	3,243
	25	8,543
	50	11,643
	Total	24,172



2) Loss amount (annual average) is expected to be reduced with the Project

In Table 4.5.2-3 results of loss amount calculation (annual average) that are expected to reduce to implement the Project are shown.

**Table 4.5.2-3 Annual average of loss reduction amount (social prices)**

Basin	Return Period	Probability	Total Damage (10 <sup>6</sup> Soles)			Average Damage ④	Section Probability ⑤	Annual Average Damage ⑥=④×⑤	Accumulation of Annual Average Damage
			Without Project ①	With Project ②	Damage Reduction ③=①-②				
PISCO	1	1.000	0	0	0		0	0	
	2	0.500	17,099	310	16,789	8,394	0.500	4,197	4,197
	5	0.200	22,817	433	22,384	19,586	0.300	5,876	10,073
	10	0.100	54,702	3,243	51,459	36,922	0.100	3,692	13,765
	25	0.040	64,250	8,543	55,707	53,583	0.060	3,215	16,980
	50	0.020	87,899	11,643	76,256	65,982	0.020	1,320	18,300

## (2) Social assessment

In Table 4.5.2-4 results of the calculation C/B, NPV and IRR at social prices are shown.

**Table 4.5.2-4 Social assessment (C/B, NPV, IRR) (at social prices)**

流域 Basin	年平均被害軽減額 Average Annual Damage Reduction Amount	評価期間被害 軽減額(15年) Damage Reduction Amount in Evaluation Period(15years)	事業費 Project Cost	維持管理費 Operation & Maintenance Cost	B/C Benefit and Cost Ratio	Net Present Value (NPV) Valor Actual Neto (VAN)	Internal Rate of Return (IRR) Tasa Interna de Retorno (TIR)
Pisco	237,897,809	107,429,935	55,430,191	4,230,554	2.13	57,079,434	27%

The social evaluation at social price level is calculated as shown in the Table 4.5.1-9 for Pisco river.

### 4.5.3 Social assessment conclusions

The social evaluation of this Project is shown as follows:

#### (1) The economic viability of the project in Pisco basin is confirmed.

Also, the following hardly quantifiable positive economical Projects effects are shown:

- Contribution to local economic development when soothing the fear due to economic activities suspension and damage
- Contribution by increasing local employment opportunities for the construction of the project
- Strengthening the local population's awareness for floods damage and other disasters
- Income increase contributions due to an stable agricultural production because flood damages are soothed
- Increase of agricultural land price

For the economic assessment results previously presented, it is considered that this Project will contribute substantially to the local economic development.

## 4.6 Sensitivity Analysis

### (1) Objective

A sensitivity analysis was made in order to clarify the uncertainty due to possible changes in the future of the socioeconomic conditions. For the cost-benefit analysis it is required to foresee the cost and benefit variation of the project, subject to assessment, to the future. However, it is not easy to perform an adequate projection of a public project, since this is characterized for the long period required from planning to the beginning of operations. Also because of the long useful life of works already in operation and the intervention of a number of uncertainties that affect the future cost and benefit of the project. So, analysis results are obtained frequently and these are discordant to reality when the preconditions or assumptions used do not agree with reality. Therefore, for the uncertainty compensation of the cost-benefit analysis it should be better to reserve a wide tolerance-margin, avoiding an absolute and unique result. The sensitivity analysis is a response to this situation.

The objective of the sensitivity analysis is to provide the cost-benefit analysis results a determined margin that will allow a proper managing of the project's implementation, give numbers to the population and achieve greater accuracy and reliability of the project's assessment results.

### (2) Sensitivity analysis

#### 1) General description of the sensitivity analysis

There are three methods of the sensitivity analysis, as indicated in Table 4.6-1.

**Table 4.6-1 Sensitivity analysis methods**

Methods	Description	Products
Variables sensitivity analysis	It consists in changing only one predetermined variable (precondition or hypothesis), to assess how the analysis result is affected	Margin values from the analysis when a precondition or hypothesis varies
Better and worst alternatives	It consists in defining the cases in which the analysis results are improved or worsen when changing the main pre-established preconditions or hypothesis to assess the analysis result margin	Margin values from the analysis when the main precondition or hypothesis vary
Monte Carlo	It consists in knowing the probability distribution of the analysis results by simulating random numbers of Monte Carlo simulation of pre-established preconditions and hypothesis	Probable results distribution when all main precondition or hypothesis vary

#### 2) Description of the sensitivity analysis

In this project the sensitivity analysis method of the variables usually used in public works investments was adopted. Next, the scenarios and economic indicators used in the sensitivity analysis are shown.

**Table 4.6-2 Cases subjected to the sensitivity analysis and economic indicators**

Indicators	Variation margin according to factors	Economic indicators to be evaluated
Construction cost	In case the construction cost increases in 5 % and 10 %	IRR, NPV, C/B
Benefit	In case of reducing the benefit in 5 % and 10 %	IRR, NPV, C/B
Social discount rate	In case of increase and reduction of the discount social rate in 5 % respectively	NPV, C/B

### 3) Results of the sensitivity analysis

In Table 4.6-3 the results of the sensitivity analysis of each assessed case to private and social prices are shown.

**Table 4.6-3 Results of the sensitivity analysis of IRR, C/B and NPV**

	Basin	Item	Basic Case	Case 1	Case 2	Case 3	Case 4	Case 5	Case 6
				Cost increase 5%	Cost increase 10%	Benefit decrease 5%	Benefit decrease 10%	Disc.rate increase 5%	Disc. rate decrease 5%
PRIVATE PRICE	PISCO	IRR (%)	21%	20%	19%	20%	19%	21%	21%
		B/C	1.74	1.66	1.58	1.65	1.56	1.34	2.33
		NPV(s)	44,377,936	41,471,590	38,565,243	39,140,315	33,902,693	19,082,579	86,701,555
SOCIAL PRICE	PISCO	IRR (%)	27%	25%	24%	25%	24%	27%	27%
		B/C	2.13	2.04	1.95	2.03	1.92	1.65	2.86
		NPV(s)	57,079,434	54,657,431	52,235,427	51,707,937	46,336,440	30,344,695	101,432,164

### (3) Assessment of the sensitivity analysis

The impact on the economic evaluation due to the socio-economic change in the Project is as follows:

As to Pisco river, the project has high economic viability even in the base case so that IRR, B/C and NPV have no significant variation for the change of cost or benefit of the projects, and they are still effective projects.

## 4.7 Risk Analysis

The risk analysis is performed for flood prevention facilities of Chincha basin.

### (1) Definition of risk

The increase % of cost and decrease % of benefit which make NPV value equal to zero, are calculated, then the magnitude of risk is defined as shown below.

High risk : When the cost increases from 0% to less than 15% or the benefit decrease from 0% to less than 15%, NPV becomes zero.

Middle risk: When the cost increases more than 15% to less than 30% or the benefit decrease more than 15% to less than 30%, NPV becomes zero.

Low risk: When the cost increases more than 30% or the benefit decrease more than 30%, NPV becomes zero.

**(2) Magnitude risk in each basin**

The increase % of cost and decrease % of benefit which make NPV equal to zero, are calculated as shown in the Table 4.7-1. According to the Table, the risk is very low in Pisco basin

**Table 4.7-1 Increase % of cost and decrease % of benefit for NPV=0%**

		(Amount:1,000 soles)						
Basin	Construction Cost				Benefit			
	Base Case	Increase	Rate (%)	Risk	Base Case	Decrease	Rate (%)	Risk
Pisco	59,027	139,239	136%	low	107,430	50,351	53%	low

## **4.8 Sustainability Analysis**

This project will be implemented by the central government (through the DGIH), irrigation committees and regional governments. Also, the project cost will be covered with the respective contributions of the three parties. Although the sharing percentage will be determined through discussions among stake holders, the percentage is assumed provisionally 80% for the central government (in this case MINAG), 15% for regional government and 5% for irrigation committee. On the other hand, the operation and maintenance (O & M) of the completed works is assumed by the irrigation committee. So, the sustainability of the project depends on the profitability of the Project and the ability of the irrigation committees for O & M.

### **(1) Profitability**

The profitability of projects in Pisco basin is high enough as shown in 4.5 social evaluation so that there is no questionable point in the sustainability of the Project.

### **(2) Irrigation committee**

The irrigation committee is non-profitable organization established by local people based on the law (Resolución Ministerial N° 0837-87-AG) issued on October 14, 1987. Peru irrigation committee is composed of 114 committees which are divided into 1582 sectors. It is registered to the National Committee (Junta Nacional, composed of 7 members elected by all irrigation committees) and acts as an representative of agricultural sector in all Peru, and recognized in the various sectors such as public and private agricultural departments. Each irrigation committee is composed of plural irrigation sectors. The irrigation sector means the unit irrigation area which has same characteristics of irrigation area with same topography, and same intake, secondary and thirdly irrigation canals etc.

The decisions of committee is made by the Assignment Board (Cesión de Consejo Directivo) held twice per month, which is composed of 7 members such as president, vice president, secretary, 2-directors, accountant and assistant accountant etc. The main task of the committee is as follows:

- To promote the agreement of will among members and to integrate members' will as the opinion of the committee
- Effective and fair distribution of water resources
- Administration and operation and maintenance of hydraulic facilities
- Education and capacity building for water resources
- Promotion of agricultural development and increase of life quality by increase of income

### **(3) Capacity of operation and maintenance**

The recent annual budget of the irrigation committee of Pisco basin is as shown in the Table 4.8-1.

**Table 4.8-1 Irrigation committee's budget**

Rivers	Annual Budget			
	(Unit/ S)			
	2007	2008	2009	2010
Pisco	1,648,019.62	1,669,237.35	1,725,290.00	1,425,961.39

The annual revenue of irrigation committee is composed of ① irrigation water cost (/m3), ② rental cost of heavy equipment to private company etc. and there is no governmental subsidy. And the annual expenditure is composed of ① operation cost of intake facilities (operator cost of intake weir etc.) ② operation and maintenance cost for such as irrigation canal and intake etc., ③ investigation cost for upgrading of irrigation facilities, ④ operation cost for irrigation committee office.

On the other hand the required operation and maintenance cost is as shown in the Table 4.8-2 according to the clause 4.4.1. The ratio of O/M cost to the annual budget in 2009 and to the annual average of the damage reduction amount are also as shown in the same table. The ratio of O/M cost to the annual budget in 2009 is 22.2 % in Pisco river. On the other hand the ratio of O/M cost to the annual average of the damage reduction amount is 2.1 %, which seems to be very low.

The ratio of O/M cost to the annual budget seems to be rather high, however the ratio of O/M cost to the annual average flood damage amount is very low so that after the flood damage is reduced and profit of farmer increase, it is quite possible that the irrigation committee bears the O/M cost.

And the committee has heavy equipment such as bull-dozer, excavator, trailer, dump truck etc. and performed maintenance works for dike, revetment, intake, irrigation channel etc. therefore the committee could carry out the O/M of the facilities constructed in the Project under the technical assistance of MINAG and the regional government.

**Table 4.8-2 Ratio of O/M cost to annual budget and damage reduction amount**

Irrigation Committee	Annual Budget(1,000soles)	O/M Cost(1,000soles)	Percentage of O/M cost(%)	Average Yearly Damage Reduction(1,000soles)	Percentage of O/M cost(%)
	①	②	③=②/①	④	⑤=②/④
Pisco	1,725	383	22.2	17,844	2.1

**(4) Agreement with irrigation committee**

The following items are to be discussed and made agreement between the central government (MINAG) and the irrigation committee as soon as possible.

- Sharing ratio of Project cost
- Delivery of flood prevention facilities
- O/M of facilities
- Delivery of plantation along river structure and O/M

## 4.9 Environmental Impact

### 4.9.1 Procedure of Environmental Impact Assessment

Projects are categorized in three scales, based on the significance level of the negative and positive impacts, and each sector has an independent competence on this categorization. The following table shows the environmental management instruments that are required for each category. The Project holder should submit the Environmental Impact Statement (DIA, in Spanish) for all Projects under Category I. The project holder should prepare an EIA-sd or an EIA-d if the Project is categorized under Category II or III, respectively, to be granted the Environmental Certification from the relevant Ministry Directorate.

**Table 4.9.1-1 Project categorization and environmental management instruments**

	Description	Required Environmental Management Instrument
Category I	It includes those Projects that when carried out, they cause no significant negative environmental impacts whatsoever.	PEA that is considered a DIA after the assessment for this category
Category II	It includes those Projects that when carried out, they can cause moderate environmental impacts, and their negative effects can be removed or minimized through the adoption of easily applicable measures.	Semi-Detailed Environmental Impact Assessment (EIA-sd)
Category III	It includes those Projects than can cause significant quantitative or qualitative negative environmental impacts because of their characteristics, magnitude and/or location. Therefore, a deep analysis is required to revise those impacts and set out a relevant environmental management strategy.	Detailed Environmental Impact Assessment (EIA-d)

Source: Prepared by the JICA Study Team based on the SEIA Law (2001)

The next graph shows the Environmental Document's Classification, the Environmental Document's Assessment, and the Environmental Certification.

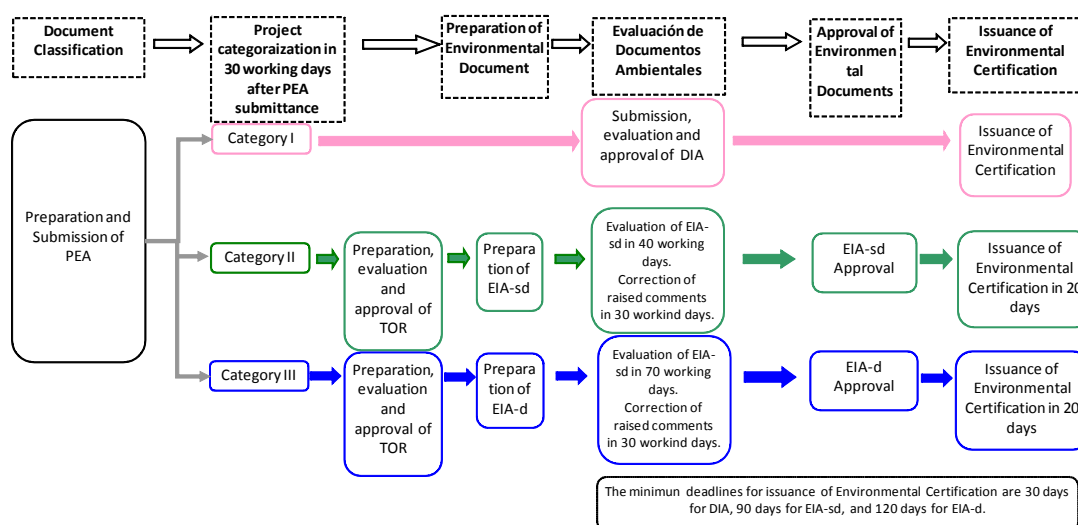

Source: Prepared by the JICA Study Team based on the SEIA Regulations (2009)

**Figure 4.9.1-1 Process to obtain the environmental certification**

First, the Project holder applies for the Project classification, by submitting the Preliminary Environmental Assessment (PEA). The relevant sector assesses and categorizes the Project within the next 30 working days after the document’s submission. The Project’s PEA that is categorized under Category I becomes an EID, and those Projects categorized under Category II or III should prepare an EIA-sd or EIA-d, as applicable. There are cases in which the relevant sector prepares the Terms of Reference for these two studies, and submits them to the holder. There are other cases in which the holder prepares the Terms of Reference and these are approved by the relevant sector, based on the interview with DGAA. Number of working days required for EIA-sd revision and approval is 90, and number of working days required for EIS-d is 120; however, these maximum deadlines may be extended. The progress of the environmental impact study is as shown below.

The JICA Study Team subcontracted a local Consultant (CIDE Ingenieros S.A.), and a Preliminary Environmental Assessment (PEA) was carried out, from December 2010 to January 2011 for Pisco river.

EAP for the Pisco river was submitted to DGIH from JICA on January 25, 2011. DGIH submitted the EAP to DGAA on July 19, 2011. EAP for Pisco river was examined by DGAA, and DGAA issued their comments on EAP to DGIH. JICA Study Team revised EAP upon the comments and submitted it to DGAA on September 21, 2011. DGAA completed examination on the revised EAP and issued approval letter on Pisco river in which DGAA classified Pisco river into Category I. Therefore the additional environmental impact analysis for Pisco river is not required.

The positive and negative environmental impact associated with the implementation of this project was confirmed and evaluated, and the plan for prevention and mitigation measures are prepared by EAP results, field investigation and hearing by JICA Study Team.



The proposed works in this project include: the reparation of existing dikes, construction of new dikes, riverbed excavation, bank protection works, repair and improvement of the derivation and intakes works, and also river expansion. Table 4.9.1-2 describes “working sites” to be considered in the Environmental Impact section for Pisco river.

**Table 4.9.1-2 Works description**

River	Location		Critical Point	Main Protection Objects	Measure	Feature of Work	
Rio Pisco	Pi-1	3.0-5.0 km	Innuded Point	Agrictural Lands	Dike with Bank Protection	Length Dike with Bank Protection Large Boulder Riplap	4,120 m 92,900 m <sup>3</sup> 32,200 m <sup>3</sup>
	Pi-2	6.5-7.9 km	Narrow Section		Riverbed Excavation, Dike with Bank Protection	Riverbed excavation Dike with Bank Protection Large Boulder Riplap	L=1,200 m, V=74,900 m <sup>3</sup> L=2,950 m, V=42,520 m <sup>3</sup> 25,000 m <sup>3</sup>
	Pi-3	12.4-13.9 km	Innuded Point		Dike with Bank Protection	Length Dike with Bank Protection Large Boulder Riplap	1,500 m 33,900 m <sup>3</sup> 12,600 m <sup>3</sup>
	Pi-4	19.5-20.5 km	Innuded Point	Agrictural Lands	Dike with Bank Protection	Length Dike with Bank Protection Large Boulder Riplap	1,010 m 17,400 m <sup>3</sup> 8,060 m <sup>3</sup>
	Pi-5	25.8-26.4 km	Narrow Section		Riverbed Excavation, Dike with Bank Protection	Riverbed excavation Dike with Bank Protection Large Boulder Riplap	L=600 m, V=67,600 m <sup>3</sup> L=1,250 m, V=29,900 m <sup>3</sup> 10,600 m <sup>3</sup>
	Pi-6	34.5-36.4 km	Existing Intake Weir (Sediment Retuding Basin 1,800 x 700m)		Riverbed Excavation- Dike with Bank Protection	Riverbed excavation Outer Dike/ Bank protection Large Boulder Riplap Inner Dike/ Bank protection Large Boulder Riplap	L=1,900 m, V=496,000 m <sup>3</sup> L=2,050 m, V=103,600 m <sup>3</sup> 19,900 m <sup>3</sup> L=3,750 m, V=114,000 m <sup>3</sup> 63,100 m <sup>3</sup>

Source: JICA Study Team

## 4.9.2 Methodology

In order to identify environmental impacts of the works to be executed in the different watersheds, we developed identification impact matrixes for watershed.

First, the operation and activities for each project based on typical activities of “hydraulic works” construction were determined. Afterwards, the concrete activities type was determined which will be executed for each work that will be developed in the watersheds. Then, to evaluate Socio-environmental impacts the Leopold matrix was used.

**Table 4.9.2-1 Evaluation criterion - leopold matrix**

Index		Description	Valuation
“Na” nature		It defines whether change in each action on the means is positive or negative	Positive (+) : beneficial
			Negative (-): harmful
Probability of Occurrence “P.O.”		It includes the probability of occurrence of the impact on the component	High (>50 %) = 1.0
			Medium (10 – 50 %) = 0.5
			Low (1 – 10 %) = 0.2
Magnitude	Intensity (In)	It indicates the magnitude of change in the environmental factor. It reflects the degree of disturbance	Negligible (2)
			Moderate intensity (5)
			Extreme Disturbance (10)
	Extension “Ex”	It indicates the affected surface by the project actions or the global scope on the environmental factor.	Area of indirect influence: 10
			Area of direct influence: 5
			Area used up by the works: 2
	Duration “Du”	It refers to the period of time when environmental changes prevail	> 10 years: 10
			5 – 10 years : 5
1 – 5 years: 2			
Reversibility “Rev”	It refers to the system’s capacity to return to a similar, or an equivalent to the initial balance.	Irreversible: 10	
		Partial return: 5	
		Reversible: 2	

Source: Prepared based on PEAs of 6 Basins

**Table 4.9.2-2 Impact significance degrees**

SIA	Extent of Significance
≤ 15	Of little significance
15.1 - 28	Significant
≥ 28	Very significant

Source: Prepared based on PEAs of 6 Basins

### 4.9.3 Identification, Description and Social Environmental Assessment

#### (1) Identification of social environmental impacts

In the following matrix (construction/operation stages) in the watershed, elaborated based on the report analysis of the Preliminary Environmental Assessment.

**Table 4.9.3-1 Impact Identification matrix (construction and operation stage) – Pisco river**

Construction Stage			Work	1-6	1-6	1,3,4	1-6	5	1-5	1,3,4,6	1,3,4,6	1-6	1-5	1-6	1-6	Total Negative	Total Positive	
Environment	Component	Environmental Factors	Activity	Labor Recruitment	Site preparation work (Cleaning, land grading, Levelled)	Diversion of riverbed (Cofferdams)	Digging and movement of Land	Digging and refilling in riverside	Digging and refilling in riverbed	Civil Work (Concreting)	I&O of stone pits and material production plants	DME I&O	Camps work I&O	Carriage Staff	Transportation of machinery, equipment, materials and supplies			
Physique	Air	PM-10 (Particulate matter)		N	N	N	N	N	N	N	N	N	N	N	N	9	0	
		Gas emissions		N	N	N	N	N	N	N	N	N	N	N	N	N	10	0
	Noise	Noise																
		Soil fertility			N												2	0
	Soil	Land Use			N												3	0
		Calidad del agua superficial				N			N	N				N			5	0
	Water	Cantidad de agua superficial									N						1	0
		Physiography	Morfología fluvial				N		N	N							4	0
Morfología terrestre				N			N					N				3	0	
Biotic	Flora	Terrestrial flora			N								N			2	0	
		Aquatic flora				N		N	N							4	0	
	Fauna	Terrestrial fauna			N								N			2	0	
		Aquatic fauna				N	N	N	N			N				5	0	
Socio-economic	Esthetic	Visual landscape			N							N	N			3	0	
		Quality of life		P									N	N	N	3	1	
	Social	Vulnerability - Security														0	0	
		PEA			P											0	1	
Economic	Current land use															0	0	
																0	0	
<b>Total</b>				2	9	7	5	7	7	3	9	9	3	4	4	67	2	
<b>Percentage of positive and negative</b>																97 %	3 %	

Operation Stage			Works		Total Negative		Total Positive		
Environment	Component	Environmental Factors	Dike-Left Side Point 1	Riverbed without Sliding Point 2	Dike-Left Side Point 3	Dike-Right Side Point 4	extended Riverbed Punto 5	Well of Control Point 6	
Physique	Air	PM-10 (Particulate matter)							
		Gas emissions							
	Noise	Noise							
		Soil fertility							
	Soil	Land Use							
		Calidad del agua superficial							
	Water	Cantidad de agua superficial	P	P	P	P			
		Physiography	Morfología fluvial	N	N	N	N		
Morfología terrestre									
Biotic	Flora	Terrestrial flora							
		Aquatic flora							
	Fauna	Terrestrial fauna							
		Aquatic fauna	N	N	N	N			
Socio-economic	Esthetic	Visual landscape	P	P	P	P			
		Quality of life	P	P	P	P	P	P	
	Social	Vulnerability - Security	P	P	P	P	P	P	
		PEA							
Economic	Current land use	P	P	P	P	P	P		
<b>Total</b>			7	7	7	7	3	8	
<b>Percentage of positive and negative</b>								24 %	76 %

N: Negative, P:Positive

Source: Prepared by the JICA Study Team

On the Pisco River basin, based on the impact identification results for the construction stage, a total number of 69 interactions have been found. 67 of these interactions (97 %) correspond to impacts that will be perceived as negative, and 2 (3 %) correspond to impacts that will be perceived as positive. In addition, 34 interactions have been found for the operation stage; 8 of these interactions (24 %) correspond to impacts that will be perceived as negative, and 26 (76 %) correspond to impacts that will be perceived as positive.

## (2) Environmental and social impact assessments

Environmental and social impacts are assessed with the methodology that was explained in 4.9.2 Methodology. The following tables show the environmental and social assessment results for the basin, during the construction and operation stages.

**Table 4.9.3-2 Environmental impact assessment matrix – Pisco river**

			The Pisco River Basin																	
Medio	Componente	Acciones del proyecto	Construction Stage						Operation Stage											
			Civil Work (Concreting)		I&O of stone pits and material production plants		DME I&O		Camps work I&O		Carnage Staff		Transportation of machinery, equipment, materials and supplies		P11	P12	P13	P14	P15	P16
			Pi 1,3,4 y 6	Pi 1,3,4 y 6	Pi 1-6	Pi 1-5	Pi 1-6	Pi 1-6												
Factores Ambientales			Puntos de Obras:																	
Physique	Air	PM-10 (Particulate matter)	0.0	-11.5	-18.0	0.0	-11.5	-11.5	0.0	0.0	0.0	0.0	0.0	0.0	0.0	0.0	0.0	0.0	0.0	0.0
		Gas emissions	-11.5	-11.5	-11.5	0.0	-11.5	-11.5	0.0	0.0	0.0	0.0	0.0	0.0	0.0	0.0	0.0	0.0	0.0	0.0
	Noise	Noise	-15.0	-12.0	-15.0	-15.0	-12.0	-12.0	0.0	0.0	0.0	0.0	0.0	0.0	0.0	0.0	0.0	0.0	0.0	0.0
		Soil	Soil fertility	0.0	0.0	-14.2	0.0	0.0	0.0	0.0	0.0	0.0	0.0	0.0	0.0	0.0	0.0	0.0	0.0	0.0
	Water	Land Use	0.0	-15.0	-15.0	0.0	0.0	0.0	0.0	0.0	0.0	0.0	0.0	0.0	0.0	0.0	0.0	0.0	0.0	0.0
		Calidad del agua superficial	0.0	-15.0	0.0	-15.0	0.0	0.0	0.0	0.0	0.0	0.0	0.0	0.0	0.0	0.0	0.0	0.0	0.0	0.0
	Physiography	Cantidad de agua superficial	-9.0	0.0	0.0	0.0	0.0	0.0	26.0	31.0	26.0	26.0	0.0	0.0	0.0	0.0	0.0	0.0	0.0	
Morfología fluvial		0.0	-23.0	0.0	0.0	0.0	0.0	-25.5	-30.5	-25.5	-25.5	0.0	0.0	0.0	0.0	0.0	0.0	0.0		
Biotic	Flora	Morfología terrestre	0.0	0.0	-28.0	0.0	0.0	0.0	0.0	0.0	0.0	0.0	0.0	0.0	0.0	0.0	0.0	0.0	0.0	
		Terrestrial flora	0.0	0.0	-22.5	0.0	0.0	0.0	0.0	0.0	0.0	0.0	0.0	0.0	0.0	0.0	0.0	0.0	0.0	
	Aquatic flora	0.0	-14.5	0.0	0.0	0.0	0.0	0.0	0.0	0.0	0.0	0.0	0.0	0.0	0.0	0.0	0.0	0.0		
	Fauna	Terrestrial fauna	0.0	0.0	-22.5	0.0	0.0	0.0	0.0	0.0	0.0	0.0	0.0	0.0	0.0	0.0	0.0	0.0	0.0	
		Aquatic fauna	0.0	-15.0	0.0	0.0	0.0	0.0	-25.5	-30.5	-25.5	-25.5	0.0	0.0	0.0	0.0	0.0	0.0		
Socio-economic	Esthetic	Visual landscape	0.0	-12.0	-12.0	0.0	0.0	0.0	36.0	36.0	36.0	36.0	36.0	0.0	0.0	0.0	0.0	0.0	0.0	
		Quality of life	0.0	0.0	0.0	-18.0	-18.0	-17.5	36.0	36.0	36.0	31.0	41.0	36.0	36.0	36.0	36.0	36.0	36.0	
	Social	Vulnerability - Security	0.0	0.0	0.0	0.0	0.0	0.0	36.0	36.0	36.0	31.0	41.0	36.0	36.0	36.0	36.0	36.0		
		PEA	0.0	0.0	0.0	0.0	0.0	0.0	0.0	0.0	0.0	0.0	0.0	0.0	0.0	0.0	0.0	0.0		
	Economic	Current land use	0.0	0.0	0.0	0.0	0.0	0.0	36.0	36.0	36.0	36.0	41.0	36.0	36.0	36.0	36.0	36.0		

Grade of Positive Impacts		Grade of Negative Impacts	
0-15.0	Little significant	0-15.0	Little significant
15.1-28.0	Significant	15.1-28.0	Significant
28.1-	Very significant	28.1-	Very significant

Source: Prepared based on PEAs of 6 Basins

It must be pointed out that in the Pisco River basin only 12 out of a total of 67 negative impacts have been quantified as significant, and 2 have been quantified as very significant, during the construction

stage. Meanwhile, out of a total of 8 negative impacts, only 6 have been quantified as significant, and 2 have been quantified as very significant, during the operation stage.

During the construction stage, the works site preparation component will significantly affect the land morphology. At the same time, the Riverbed Excavation and Filling component will affect the “Pi1”, “Pi2”, “Pi3”, and “Pi4” points. During the operation stage, river morphology and aquatic fauna will be significantly affected at the “Pi2” points, where the river basin will be unclogged.

During the construction stage, actions that will generate most significant negative impacts along the basin include: “Site Works Preparation and Clearance”, “Riverbed Excavation and Filling”, and “Surplus Material Deposits Operation (DME, in Spanish).” “Site works Preparation and Clearance” will bring about a significant modification to the land morphology, whereas “Riverbed Excavation and Filling” will bring about a significant modification to river morphology.

During the operation stage, hydraulic infrastructure works that will bring about most significant negative environmental impacts include “Riverbed excavation and embankment” that will cause a modification to the river morphology and subsequently, decreased river habitability conditions that will directly impact the aquatic fauna.

Most significant positive impacts are related to all works to be constructed along the river basins, and are directly related to improve the quality of the lives of the population around the area of influence, improve the “Current Use of land / soil”, improve the security conditions, and reduce vulnerability at social and environmental levels.

#### **4.9.4 Socio-Environmental Management Plans**

The objective of the Socio-Environmental Plans is to internalize both positive and negative significant and very significant environmental impacts that are related to the Project’s construction and operation stages, so that prevention and/or mitigation of significant and very significant negative impacts, preservation of environmental heritage, and Project sustainability are ensured.

During the construction stage, Project of Pisco river has set out the following measures: “Local Hiring Program”, “Works Sites Management and Control Program”, “Riverbed Diversion Program”, “Riverbank Excavation and Filling Management”, “Riverbed Excavations and Filling Management”, “Quarry Management”, “DME Management”, “Camp and Site Residence Standards”, and “Transportation Activity Management.” During the operation stages, Project for the basin has considered the development of activities with regard to “Riverbed and Aquatic Fauna Management”. These activities should develop riverbed conditioning downstream the intervention points, for erosion probabilities to be reduced, and habitability conditions to be provided for aquatic fauna species. The following are measures related to those negative impacts to be mitigated or those positive impacts to be potentiated. Overall measures have been established for the basin, based on the impacts.

**Table 4.9.4-1 Environmental impact and prevention/mitigation measures**

<b>Item</b>	<b>Impact</b>	<b>Counter Measures</b>	<b>Period</b>
Natural environment	Water quality of surface water	Management of river diversion and coffering	Construction period
		Management of bank excavation and banking	
		Management of riverbed excavation and back filling	
	River topography	Management of bank excavation and banking	
		Management of riverbed excavation and back filling	
		Management of quarry site	
	Other topography	Management of construction site	
		Management of large amount of excavated or dredged material	
Dust	Management of construction site		
	Management of large amount of excavated and dredged material		
Biological environment	Aquatic fauna	Management of riverbed excavation and back filling	O/M period
	Terrestrial fauna	Management of construction site	Construction period
		Management of large amount of excavated and dredged material	
	Terrestrial flora	Management of construction site	
		Management of large amount of excavated and dredged material	
Social environment	Quality of life	Management of labor and construction office	
		Management of traffic of construction vehicle	
		Employment plan of local people	
	Population of economic activity	Employment plan of local people	

Source: JICA Study Team

## 4.9.5 Monitoring and Control Plan

### (1) Follow up and monitoring plan

The follow-up plan has to implement firmly the management of environmental plan. The monitoring plan is to be carried out to confirm that the construction activity fulfill the environmental standard such as Environmental Quality Standards (EQS) either or Maximum Permissible Limits (MPL). And the monitoring and control must be carried out under the responsibility of the project's owner or a third party under the supervision of the owner.

#### Construction stage

During the construction period of the projects to be done in the watershed, the Monitoring and Control Plan will be directed to the verification of the fulfillment measures designed as part of the environmental monitoring plan and the verification of the fulfillment of laws and regulation of the Peruvian Legislation. The following aspects will also be monitored:

#### Water Quality and Biological Parameters:

Water quality and biodiversity parameters control shall be performed at downstream of these works must be monitored. In the following table the profile of this plan is shown.

**Table 4.9.5-1 Monitoring to water quality and biological parameters**

Item	Unit	Measured Value (Mean)	Measured Value (Max.)	Country's Standards
pH	pH			"National Standard for Water Quality" D.S. No. 002-2009 MINAM
TSS	mg/l			
BOD/COD	mg/l			
DO	mg/l			
Total Nitrogen	mg/l			
Heavy Metals	mg/l			
Temperature	°C			
Biological Diversity indices: Shannon; Pielou; richness and abundance				

[Measurement Points]

-50 meters upstream the intervention points

-50 meters downstream the intervention points

-100 meters downstream the intervention points

[Frequency]

Quarterly

[Person in charge of Implementation]

DGIH-MINAG, or a third party under the project holder's supervision

Source: JICA Study Team

#### Air Quality:

During impact analysis, in the projects to be developed in the watershed no significant impacts will be seen in the activities related to hydraulic infrastructure works. However, the generation of dust

and atmospheric contaminant emissions always affects the working area and the workers and inhabitants health. So, it is recommended to monitor air quality.

**Table 4.9.5-2 Monitoring to air quality**

Item	Unit	Measured Value (Mean)	Measured Value (Max.)	Peruvian Standards (D.S. No 074-2001-PCM)	Referred International Standards
SO <sup>2</sup>				"National Standard for Air Quality" D.S. No.074-2001-PCM	National Ambient Air Quality Standards (NAAQS) (Updated in 2008)
NO <sup>2</sup>					
CO					
O <sup>3</sup>					
PM-10					
PM-2.5					

[Measurement Points]

\*02 stations per monitoring point: Windward and downwind (upwind and against the wind direction)

-1 point at the working zones

-1 point at a quarry, away from the river (the largest and / or the closest point to a populated area)

-1 point at a D.M.E. (the largest and / or the closest point to a populated area)

[Frequency]

Quarterly

[Person in charge of the Implementation]

DGIH-MINAG, or a third party under the project holder's supervision

Source: JICA Study Team

### Noise Quality

Likewise, it is proposed to perform a noise monitoring at the potential receptors located near the noise emission spots towards the working sites, in the next table 4.9.5-3, the terms are described.

**Table 4.9.5-3 Monitoring to noise quality**

Item	Unit	Measured Value (Mean)	Measured Value (Max.)	Country's Standards	Referred International Standards
Noise level	LAeqT (dB(A))			National Environmental Quality Standards for noise (EQS) - S.N. N° 085-2003-PCM	-IEC 651/804 - International -IEC 61672- New Law: Replaces IECs 651/804 -ANSI S 1.4 - America

[Measurement Point]

Monitoring to acoustic contamination levels will be carried out at the potential receivers that are located around the noise emission points per work front.

01 point per potential receiver will be monitored.

[Frequency]

Every two months during construction phase

[Person in charge of the Implementation]

DGIH-MINAG, or a third party under the project holder's supervision

Source: JICA Study Team

## Operation Stages

Regarding works impact of all projects, it is mainly recommended to monitor biologic parameters and water quality as river topography and the habitat of aquatic life.

**Table 4.9.5-4 Monitoring to water quality (operation stage)**

Item	Unit	Measured Value (Mean)	Measured Value (Max.)	Country's Standards
pH	pH			"National Standard for Water Quality" D.S. No. 002-2009 MINAM
TSS	mg/l			
BOD/COD	mg/l			
DO	mg/l			
Total Nitrogen	mg/l			
Heavy Metals	mg/l			
Temperature	°C			
Biological Diversity indices: Shannon; Pielou; richness and abundance				

[Measurement Points]

-50 meters upstream the intervention points

-50 meters downstream the intervention points

-100 meters downstream the intervention points

[Frequency]

Quarterly in first two years of operation phase

[Person in charge of Implementation]

DGIH-MINAG, or a third party under the project holder's supervision

Source: JICA Study Team

### (2) Closure or abandon plan

Closure or abandon plans have been made for each watershed. These will be executed at the end of construction activities and involves the removal of all temporary works and restoration of intervened and/or affected areas as a result of the works execution. The restoration includes the removal of contaminated soil, disposal of waste material, restoration of soil morphology and restoration with vegetation of intervened sites.

### (3) Citizen participation

Citizen participation plans have been made for each watershed, which must be executed before and during construction and when the works are completed. The recommended activities are:

- Before works: Organize workshops in the surrounding community's area near the project and let them know what benefits they will have. Informative materials in communities, which will explain the profile, lapse, objectives, benefits, etc. of the Project
- During works execution: Give out information on the construction progress. Responding complaints generated from the local community during works execution. For this, a consensus



wants to be previously achieved with the community in order to determine how claims will be met

- When works are completed: Organize workshops to inform about works completion. Works delivery to the local community inviting local authorities for the transfer of goods, which means the work finished.

#### 4.9.6 Cost for the Environmental Impact Management

The cost for the environmental management in this Project is as shown in the Table 4.9.6-1. In the table, (1) shows the cost for the environmental management of each facility, based on which the cost required in the basin (2) is calculated. And the cost for the counter measures 1) – 7) is calculated based on the accumulated construction period of each facility which is described in the Annex-9 Construction Plan/Cost Estimate, Table 2.1-1.

**Table 4.9.6-1 Cost of environmental management plan**

(1) Cost per one work site					(2) Cost per Basin
Item	Unit	Quantity	Unit Price (S/.)	Parcial Price (S/.)	Pisco Basin (6 sites)
<b>Work duration</b>	<b>Month</b>				<b>26</b>
1) Transportation Activities Program	Month	-	S/. 1,400.0	-	S/. 36,400.0
2) Industrial wastes Management Program	Month	-	S/. 4,200.0	-	S/. 109,200.0
3) Landscape management within the project site	Month	-	S/. 2,800.0	-	S/. 72,800.0
4) Worksite Management Program	Month	-	S/. 1,960.0	-	S/. 50,960.0
5) Noise control program	Month	-	S/. 1,120.0	-	S/. 29,120.0
6) Environmental Management Activities	Month	-	S/. 4,480.0	-	S/. 116,480.0
7) Training for control of foil and water contamination	Month	-	S/. 2,520.0	-	S/. 65,520.0
8) Monitoring to Water Quality, Flow, and Biological Indices				S/. 11,239.20	S/. 67,435.2
Índices de diversidad	Monitoring	3	S/. 672.0	S/. 2,016.00	
Caudal	Monitoring	3	S/. 588.0	S/. 1,764.00	
T°, pH, OD	Monitoring	3	S/. 571.2	S/. 1,713.60	
DBO	Monitoring	3	S/. 638.4	S/. 1,915.20	
Sólidos disueltos totales	Monitoring	3	S/. 638.4	S/. 1,915.20	
Sólidos suspendidos totales	Monitoring	3	S/. 638.4	S/. 1,915.20	
9) Monitoring to Ari quality and noise				S/. 37,500.0	S/. 225,000.0
Monitoring of air emission	Monitoring	3	S/. 4,500.0	S/. 13,500.0	
Monitoring of PM	Monitoring	3	S/. 5,000.0	S/. 15,000.0	
Monitoring of noise	Monitoring	3	S/. 3,000.0	S/. 9,000.0	
<b>Total</b>					<b>S/. 772,915.2</b>

#### 4.9.7 Conclusions and Recommendations

##### (1) Conclusions

According to the Preliminary Environmental Appraisals to Pisco basin, most impacts identified during

the construction and operation stages were found out to be of little significance. Significant and very significant negative impacts can be controlled or mitigated, as long as suitable Environmental Management Plans are carried out. In addition, the Project will be implemented in the short term, as environmental conditions will be quickly restored. However, the execution of a follow – up and monitoring plan is important, and in the event that unexpected impacts are generated, immediate mitigation measures must be taken.

In addition, significant positive impacts are also present, especially during the operation stage. These positive impacts include: An enhanced security / safety and a decreased vulnerability at social and environmental levels; an improved quality of life among the population in the area of influence, and an improved “Current use of land / soil”.

## **(2) Recommendations**

1) We mainly recommend that the beginning of the construction activities coincides with the beginning of the dry seasons in the region (May to November) when the level of water is very low or the river dries up. The river characteristics / features should be taken into account, that the Pisco River is seasonal rivers. At the same time, the crop season cycle in the areas of direct influence should be taken into account, so that traffic jams caused by the large trucks and farming machinery is prevented.

2) It is recommended that the Project holder (DGIH) should define the limit of river area during detailed design stage, and identify the people who live within the river area illegally. Continually the DGIH should carry on the process of land acquisition based on the Land Acquisition Law, which are; Emission of Resolution for land acquisition by the State, Proposition of land cost and compensation for land owner, Agreement of the State and land owner, Payment, archaeological assessment certification.

3) DGIH has to promote the process to obtain the CIRA in the detail design stage. The process to be taken is i) Application form, ii) Copies of the location drawings and outline drawings, iii) voucher, iv) Archaeological Assessment Certificate.

4) The participation of the women in the workshops can be promoted through the existing women group such as Vaso de Leche. Finally, the DGAA submitted the resolutions (Environmental Permissions) for Pisco basin. The project has been categorized as “Category I”, which means that the project is not required to carry out neither EIA-sd nor EIA-d.

### **4.10 Institutions and Administration**

Peruvian institutions regarding the Project’s execution and administration are the Agriculture Ministry, Economy and Finance Ministry and Irrigation Commission, with the following roles for each institution. The following description was prepared by the local consultant and governmental offices and is used in the office of DGIH.

### **(1) Ministry of Agriculture (MINAG)**

- \* The Ministry of Agriculture (MINAG) is responsible for implementing programs and the Hydraulic Infrastructure General Direction (DGIH) is responsible for the technical administration of the programs. The Hydraulic Infrastructure General Direction (DGIH) is dedicated to the coordination, administration and supervision of investment programs.
- \* In investment stage, the PSI (Programa Subsectorial de Irrigaciones, Ministerio de Agricultura) is dedicated to calculate project costs, detail design and supervision of the works execution.
- \* The Planning and Investment Office (OPI) from the Agriculture Ministry is the one responsible for pre-feasibility and feasibility studies in the pre-investment stage of DGIH projects and requests approval of DGPI (previous DGPM) from the Economy and Finance Ministry (MEF).
- \* The General Administration Office of the Agriculture Ministry (OGA-MINAG) along with the Public Debt National Direction (DGETP, previous DNEP) of the Economy and Finance Ministry is dedicated to financial management. It also manages the budget for procurement, commissioning works, contracting, etc. from the Agriculture Ministry.
- \* The Environmental Affairs General Direction (DGAA) is responsible for reviewing and approving the environmental impact assessment in the investment stage.

### **(2) Economy and Finance Ministry (MEF)**

- \* The DGPI approves feasibility studies. It also confirms and approves the conditions of loan contracts in yen. In the investment stage, it gives technical comments prior to the project execution.
- \* Financial management is in charge of DGETP (previous DNEP) from the Economy and Finance Ministry and OGA-MINAG.
- \* The Public Debt National Direction DGETP (previous DNEP) of the Economy and Finance Ministry administers expenses in the investment stage and post-investment operation.

### **(3) Irrigation Commission**

- \* Responsible for the operation and maintenance of facilities at the post-investment operation stage.

The relationship between the involved institutions in the Project's execution is shown in Figures 4.10-1 and 4.10-2.

In this Project, PSI from MINAG is scheduled to be the execution agency in the investment stage (Project execution). The PSI is currently performing JICA projects, etc. and in case of beginning a new project, it forms the correspondent Project Management Unit (PMU), and PSI is responsible of employment of international consultant with deep experience on Japanese Yen Loan project and carried out the detail design, procurement of contractor, and supervision of construction work etc. The

following figure describes the structure of the different entities involved in the Project’s execution stage. PMU is organized directly under PSI and the organization is as shown in the Figure-4.10-4.

The Agreement of Fund Transfer and Fund Management in the Figure-4.10-1 means MEF transferrs the fund to PSI and controls the expenditure.

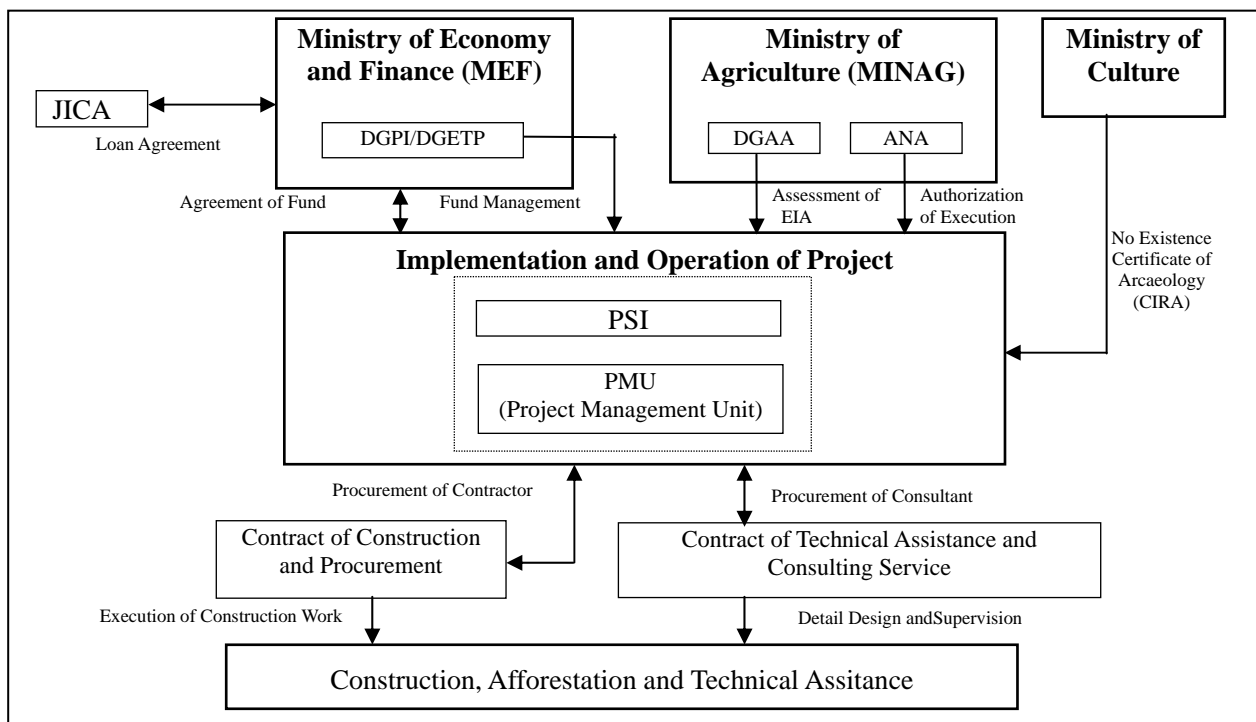

**Figure 4.10-1 Related agencies in implementation stage of project**

The main operations in the post-investment stage consist of operation and maintenance of the built works and the loan reimbursement. The O & M of the works will be assumed by the respective irrigation commission. Next, the relationship of different organizations involved in post-project implementation stage is detailed.

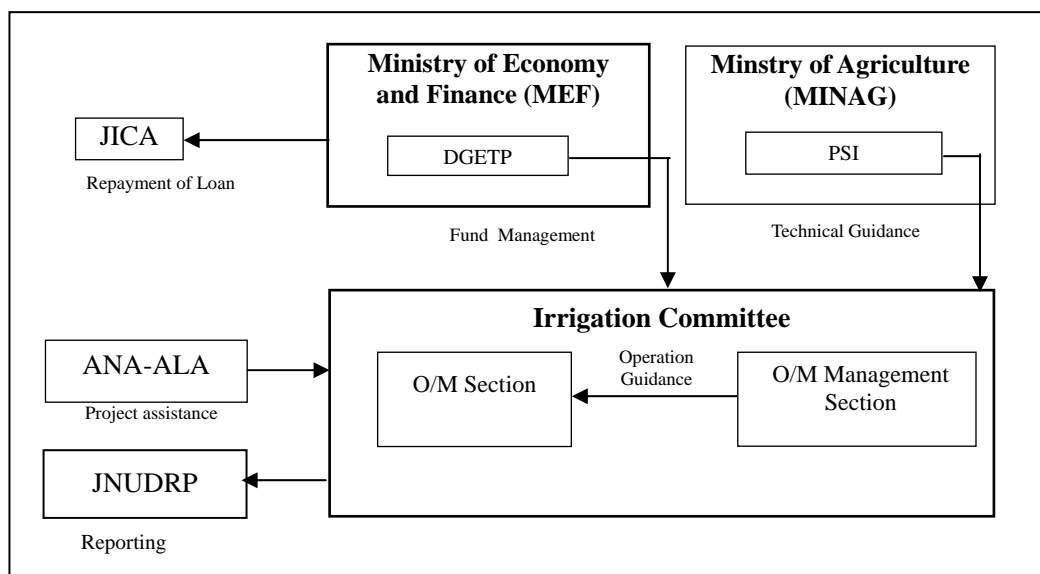

**Figure 4.10-2 Related agencies in O & M stage of project**

## **(1) DGIH**

### 1) Role and functions

The Hydraulic Infrastructure General Direction is in charge of proposing public policies, strategies and plans aimed to promoting water infrastructure development, according with the Water Resources National Policy and the Environmental National Policy.

Water Infrastructure development includes studies, works, operation, maintenance and construction risk management, fit-out, improve and expand dams, intakes, river beds, irrigation channels, drains, meters, outlets, groundwater wells and modernize plot irrigation.

### 2) Main functions

- a) Coordinate with the planning and budget office to develop water infrastructure and propose sectorial and management policies on infrastructure development. Monitor and assess the implementation of sectorial policies related to hydraulic infrastructure development
- b). Propose government, region and provinces intervention regulations, as part of sectorial policies
- c) Verify and prioritize hydraulic infrastructure needs
- d) Promote and develop public investment projects at the hydraulic infrastructure profile level
- e) Elaborate technical regulations to implement hydraulic infrastructure projects
- f) Promote technological development of hydraulic infrastructure
- g) Elaborate operation and maintenance technical standards for hydraulic infrastructure

## **(2) PSI**

### 1) Function

The Irrigation Sub-sectorial Program (PSI) is responsible of executing investment projects. A respective management unit is formed for each project.

### 2) Main functions

- a) Irrigation Sub-sectorial Program - PSI, under the Agriculture Ministry, is a body with administrative and financial autonomy. It assumes the responsibility of coordinating, managing and administering involved institutions in projects in order to meet goals and objectives proposed in investment projects
- b) Also, it coordinates the disbursements of foreign cooperation agencies financing, such as JICA.
- c) The Planning, Budget and Monitoring Office of PSI is responsible for hiring services, elaborating investment programs, as well as project execution plans. These Project preparation works are executed by hiring “in-house” consultants.
- d) Likewise, it gathers contractors, makes a lease, executes works and implements supply projects, etc.
- e) Contract management is leaded by the Planning, Budget and Monitoring Office

### 3) Budget

In Table 4.10-1 the PSI budget for 2011 is shown.

**Table 4.10-1 PSI budget (2011)**

Programs / Projects / Activities	PIM (S/.)
JBIC Program (Loan Agreement EP-P31)	69,417.953
Program - PSI Sierra (Loan Agreement 7878-PE)	7,756.000
Direct management works	1,730.793
Southern Reconstruction Fund (FORSUR)	228.077
Crop Conversion Project (ARTRA)	132.866
Technified Irrigation Program (PRT)	1,851.330
Activity- 1.113819 small farmers...	783.000
PSI Management Program (Other expenses)	7,280.005
<b>TOTAL</b>	<b>89,180,024</b>

#### 4) Organization

PSI is confirmed by 235 employees, from which 14 are assigned for JBIC Projects and 29 technicians and assistants are working under them.

**Table 4.10-2 PSI payroll**

Central Level	Data from May 31, 2011		
	CAS	Servic. and Consult.	TOTAL
Main Office	61	43	104
Zonal Office LIMA	12	24	36
Zonal Office AREQUIPA	14	12	26
Zonal Office CHICLAYO	17	13	30
Zonal Office TRUJILLO	13	26	39
<b>TOTAL</b>	<b>117</b>	<b>118</b>	<b>235</b>

In Figure 4.10-3, PSI organization is detailed:

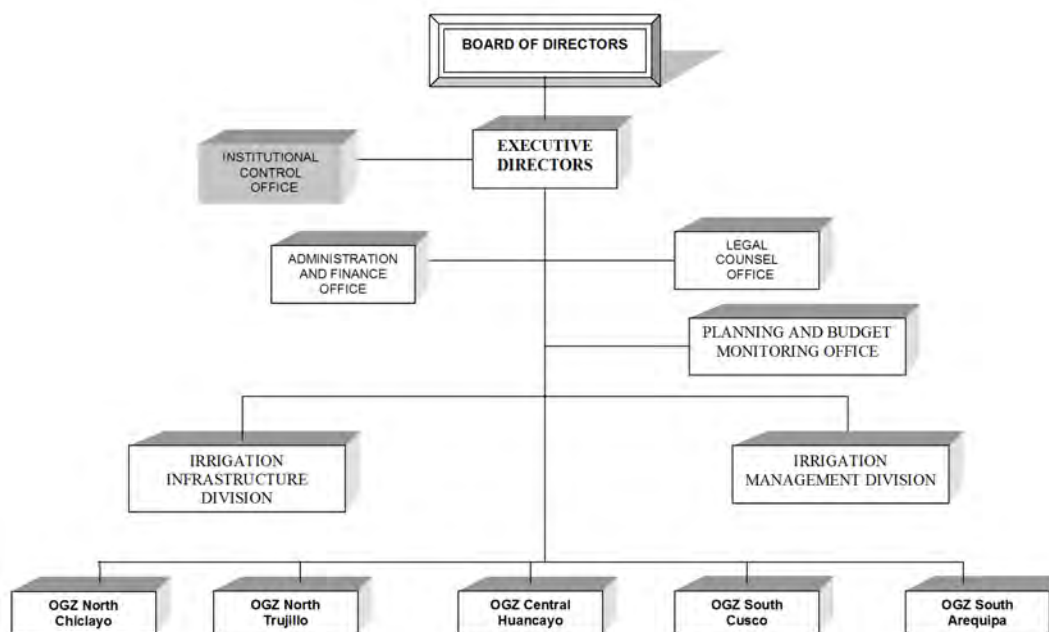
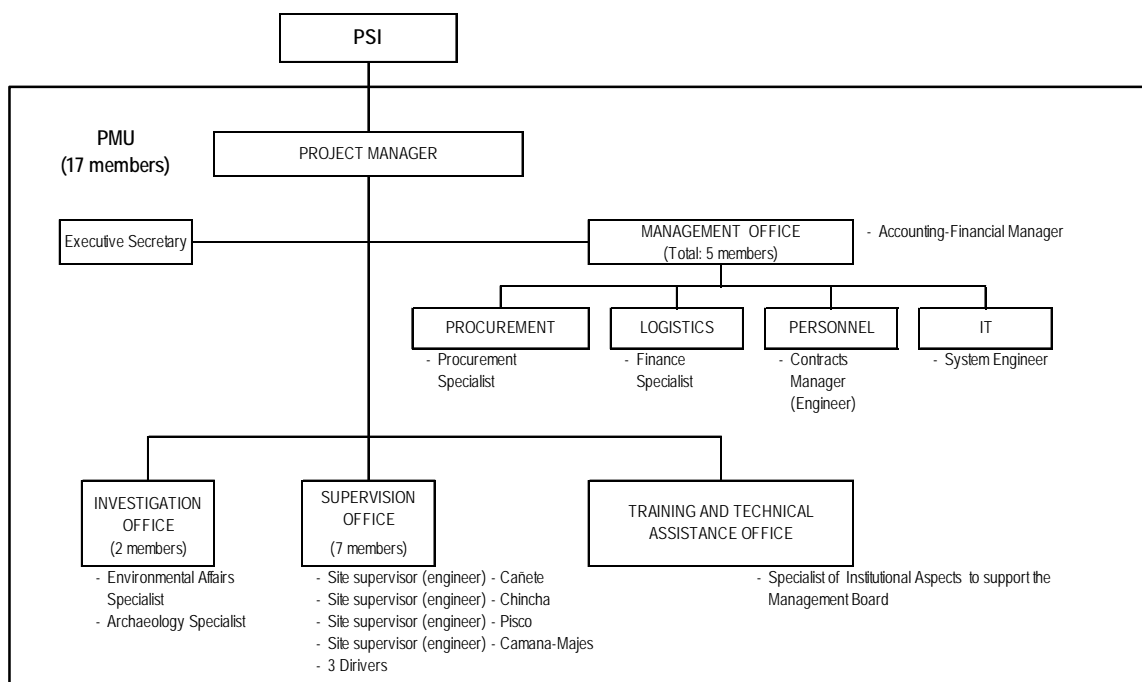

**Figure 4.10-3 Organization of PSI**

**(3) Organization of PMU (Project Management Unit)**

1) Organization

PMU is installed directly connected the Irrigation Infrastructure Division of PSI. The organization of PMU is as shown in the Figure 4.10-4.



Note: ( ) shows number of personnel

**Figure 4.10-4 Organization of PMU**

## 2) Main staff

PMU is composed of the following main staff.

- Project manager
- Contract specialist
- Construction supervisor
- IT specialist
- Procurement specialist
- Financial specialist
- Organization specialist (Adviser to the irrigation committee)
- Environmental assessment specialist
- Archeological specialist
- Accountant

## 3) Cost

The cost for operation of PMU is budgeted at 8.5 million soles as described in the clause 4.4.1, Table 4.4.1-11.

The Project will be promoted safely, by installing PMU in the implementation agency (PSI) and receiving the assistance of the consultant procured separately.

### **4.11 Execution Plan**

The Project's Execution Plan will be examined in the preliminary schedule, which includes the following components. For pre-investment stage: ① full execution of profile and feasibility studies to obtain SNIP's approval in the pre-investment stage; for the investment stage: ② signing of loans (L/A), ③ consultant selection, ④ consulting services (detailed design and elaboration of technical specifications), ⑤ constructor selection and ⑥ work execution. For the post-investment stage: ⑦ Works' completion and delivery to water users associations and beginning of the operation and maintenance stage.

#### **(1) Review by the public investment national system (SNIP)**

In Peru, the Public Investment National System (SNIP hereinafter) is under operation. This reviews the rationality and feasibility of public investment projects, and will be applied to this Project.

In SNIP, among previous studies to an investigation, it will be conducted in 3 stages: profile study (study on the project's summary), pre-feasibility and feasibility. SNIP was created under Regulation N° 27293 (published on June 28, 2000) in order to achieve efficient use of public resources for public investment. It establishes principles, procedures, methods and technical regulations to be fulfilled by central/regional governments in public investment scheme plans and executed by them.

SNIP, as described below, is all public works projects which are forced to perform a 3-stage pre-investment study: profile study, pre-feasibility and feasibility, and have them approved. However,



following the Regulation amendment in April 2011, the execution of pre-feasibility study of the intermediate stage was considered unnecessary; but in return, a study based on primary data during the profile study is requested. The required precision degree throughout all stages of the study has hardly changed before and after this modification.

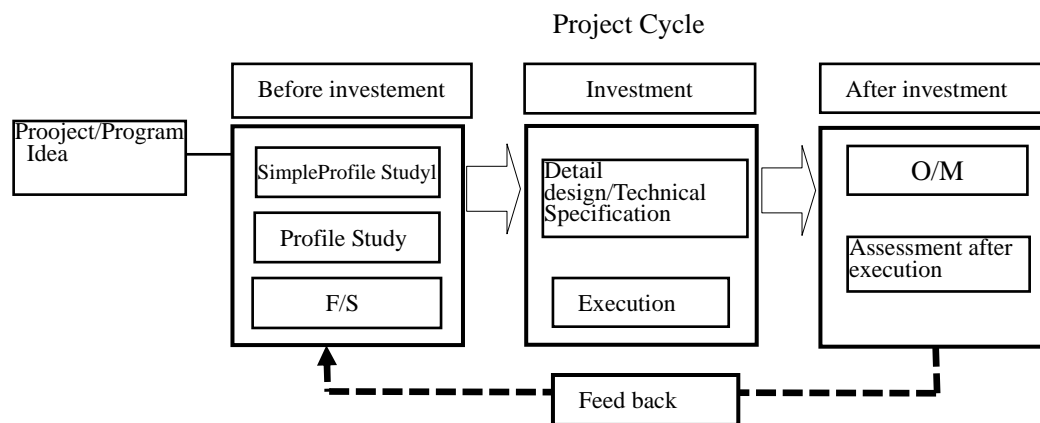

(Source : DGPI)

**Figure 4.11-1 SNIP project cycle**

In order to carry out this Project, which is a project composed by several programs, pre-investment studies at investments' programs level are required to be performed and also have them approved.

Although the procedure is a little bit different in each stage, in SNIP procedures, the project's formulation unit (UF) conducts studies of each stage, the Planning and Investment Office (OPI) assesses and approves the UF's presented studies and requests Direction General of Investment Policy (hereinafter referred to DGPI) to approve feasibility studies and initiation of following studies. Finally DGPI evaluates, determines and approves the public investment's justification.

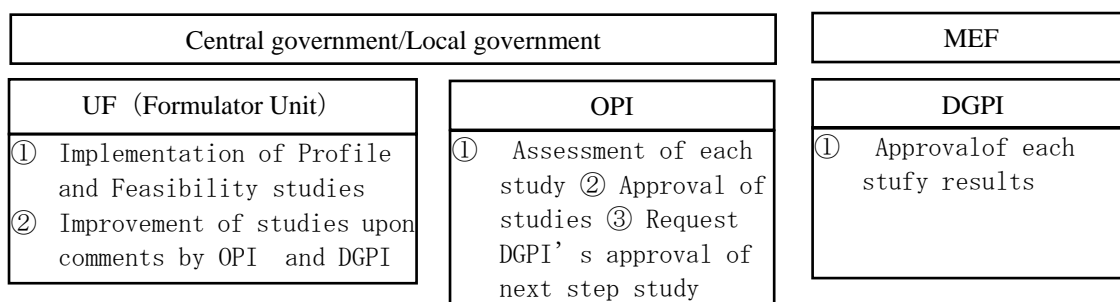

(Directiva No. 001-2009-EF/68.01)

**Figure 4.11-2 Related institutions to SNIP**

Due to the comments of examining authorities (OPI and DGPI) to UF, it will be necessary to prepare correspondent responses and improve the studies. Since these authorities officially admit applications after obtaining definitive answers, there are many cases in which they take several months from the completion of the study report until the completion of the study.

It is important to obtain well recognition of the contents and effectiveness of the project, for which UF is required to present the effect of project from the view point of study, design, construction plan as well as public investment and operation in continuity of the project. The study of natural conditions, planning of facilities, cost estimate, financial analysis etc. and also the table of contents of the study report should follow the regulation of SNIP.

DGIH registered Pisco river to SNIP on July 21, 2011 based on the Project Report of Pisco river.

OPI had examined project report with pre-F/S level of Pisco river from the end of July and issued their comments on September 22, 2011.

DGIH revised the report of Pisco river, and submitted it to OPI in May 2012. OPI transferred the revised report to DGPI with its comments in July 2012 and DGPI approved the proceed to F/S with its comments in October 2012.

## **(2) Yen loan contract**

Once the feasibility report of this Project is submitted, then the OPI and DGPI examine the contents of report, and finally the declaration of viability of the Project is to be issued by DGPI. When the declaration of viability is almost confirmed, the appraisal mission of JICA is dispatched and the negotiation of loan agreement is commenced and Loan Agreement (LA) is concluded. The period of negotiation period is assumed about 6 months (As to the details of construction time schedule, refer to Annex-9 Construction Planning and Cost Estimate).

## **(3) Procedure of the project's execution**

After the documents are assessed by SNIP and a loan agreement between Japan (JICA) and the Peruvian counterpart is signed, a consultant will be selected. The consulting service includes the detailed design and technical specifications, the contractors' selection and the work's supervision. Next find the required time for each process. Table 4.11-1 presents the Project's overall schedule.

- 1) Consultant selection: 10 months
- 2) Detailed design and technical specifications of the work: 6 months
- 3) Contractor selection: 15 months
- 4) Construction supervision by Consultant on river structures and plantation along river structures: 24 months
- 5) The afforestation along river structures is carried out in parallel with the construction.
- 6) Disaster prevention education/Capacity development is carried out from time to time in parallel with construction work.

**Table 4.11-1 Implementation plan**

Item	2010			2011			2012			2013			2014			2015			2016			2017			2018			Months
	3	6	9	12	3	6	9	12	3	6	9	12	3	6	9	12	3	6	9	12	3	6	9	12	3	6	9	
1 Profile Study/SNIP Appraisal	Study						Appraisal																		28			
2 Feasibility Study/SNIP Appraisal				Study			Appraisal																		27			
3 Loan Appraisal																									6			
4 Selection of Consultant																									10			
5 Project Management Unit																									45			
6 Consulting Services																									45			
1) Detailed Design																									6			
2) Tender Preparation, Assistance																									15			
3) Supervision																									24			
7 Selection of Contractor, Contract																									15			
8 Implementation																												
1) Structural Measures																									24			
2) Vegetation																									24			
3) Disaster Education/Capacity Building																									24			
4) Land Acquisition																									27			
9 Completion/Inauguration																									-			

#### (4) Procurement

##### 1) Employment of Consultants

The employment of consultant is to be made according to the following items:

- ① The consultants should be active in international market and have enough qualification and experience.
- ② The consultants are to have efficiency, transparency and non-discrimination among eligible consultants
- ③ The selection procedure should be taken in accordance with the stipulation in the Loan Agreement and the guideline for the Employment of Consultants under Japanese ODA Loans prepared by JICA

##### 2) Procurement of contractor

The procurement of contractors is to be made according to the following items:

- ① The procurement of contractors is to be made using due attention to considerations of economy, efficiency, transparency and non-discrimination among eligible bidders.
- ② The procurement procedure should be taken in accordance with the stipulation in the Loan Agreement and the guideline for the Employment of Consultants under Japanese ODA Loans prepared by JICA
- ③ The International Competitive Bidding: ICB is to be applied.
- ④ The pre-qualification (PQ) of bidders is to be applied in order to confirm the technical and financial capability of bidders. The following items are to be considered in PQ: a) experience of and past performance on similar contracts, b) capabilities with respect to personnel, equipment and plant, c) financial position.

## **4.12 Financial Plan**

### **(1) Sharing ratio of project cost**

This project will be implemented by the central government (through the DGIH), irrigation committees and regional governments. Also, the project cost will be covered with the respective contributions of the three parties.

As to the sharing ratio among the central government, regional government and irrigation committee, DGIH reported that in some dam project the ratio among the central government, regional government, local government and irrigation committee is 50%, 30%, 10% and 10% respectively and JICA Peru office reported that in some irrigation project, the irrigation committee bore 20%. However, there are no such examples as the flood protection project of this Project.

Considering the direct benefit received by the irrigation committee is not so much as in the irrigation project, the sharing percentage will be determined through discussions among stakeholders, the ratio is assumed provisionally 80% for the central government (in this case MINAG), 15% for regional government and 5% for irrigation committee. And the final ratio will be determined through negotiation among 3 parties.

### **(2) Financial plan**

The total project cost is 239,474 thousand soles and Japan yen loan amount is 64,750 thousand soles (25,000 thousand US\$) so that the counter fund to be borne by Peru side is 174,724 thousand soles ( $=239,474 - 64,750$ ).

The counter fund is divided into stakeholders as shown in Table 4.12-1. The contribution of regional government and irrigation committee is distributed in proportion of project cost of each basin.

**Table 4.12-1 Financial plan at implementation of project**

(thousand soles)

	Item		Amount	Remarks
1	Project cost	①	239,474	
2	Yen loan	②	64,750	25millionUS\$x2.59
	Counter fund	③	174,724	①-②
3	Central government	④	139,779	③x80%
4	regional government	⑤	26,209	③x15%
	(1) Lima (canete)	⑥	3,355	⑤x12.8%(Ratio of Project Cost)
	(2) Ica (Chincha)	⑦	5,347	⑤x20.4%(Ratio of Project Cost)
	(Pisco)	⑧	7,548	⑤x28.8%(Ratio of Project Cost)
	Subtotal	⑨	12,895	⑦+⑧
	(3) Arequipa (Majes-Camana)	⑩	9,959	⑤x38.0%(Ratio of Project Cost)
5	Irrigation committee	⑪	8,736	③x5%
	(1) Canate	⑫	1,118	⑪x12.8%(Ratio of Project Cost)
	(2) Chincha	⑬	1,782	⑪x20.4%(Ratio of Project Cost)
	(3) Pisco	⑭	2,516	⑪x28.8%(Ratio of Project Cost)
	(4) Majes-Camana	⑮	3,320	⑪x38.0%(Ratio of Project Cost)

Note) 1 US \$ = 83,6 yen = 2,59 soles, 1 sol = 32,3 yen

### (3) Repayment of loan

The yen loan shall be repaid according to the conditions stipulated in the Loan Agreement which is estimated as shown in the Table 4.12-2. The repayment will be made by the stakeholders according to the sharing ratio including the interest of loan.

**Table 4.12-2 Estimated conditions of Japan Yen Loan**

Interest	1.70%
Commitment Charge	0.10%
Maturity Period	25 years
Grace Period	7 years

### 4.13 Logical Framework of the Eventually Selected Option

In Table 4.13-1 the logical framework of the definite selected option is shown.

**Table 4.13-1 Logical framework of the definite selected option**

<b>Narrative Summary</b>	<b>Verifying Indicators</b>	<b>Verifying Indicators Media</b>	<b>Preliminary Conditions</b>
<b>Superior Goal</b>			
Promote socioeconomic local development and contribute in communities' social welfare.	Improve local productivity, generate more jobs, increase population's income and reduce poverty index	Published statistic data	Socio-economic and policy stability
<b>Objectives</b>			
Relief the high vulnerability of valleys and local continuity to floods	Types, quantity and distribution of flood control works, population and beneficiaries areas	Monitoring annual calendar works and financial plan, budget execution control	Ensure the necessary budget, active intervention from central and regional governments, municipalities, irrigation communities, local population, etc.
<b>Expected results</b>			
Reduction of number and flooded areas, functional improvement of intakes, irrigation channels protection, bank erosion control	Number of areas and flooded areas, water intake flow variation, bank erosion progress	Site visits, review of the flood control plan and flood control works reports and periodic monitoring of local inhabitants	Maintenance monitoring by regional governments, municipalities and local community, provide timely information to the superior organisms
<b>Activities</b>			
Component A: Structural Measures	Dikes rehabilitation, intake and bank protection works construction of 23 works, including dike's safety	Detailed design review, works reports, executed expenses	Ensure the works budget, detailed design/works execution/good quality works supervision
Component B: Non-Structural Measures (Reforestation and vegetation recovery)	Reforested area, coastal forest area	Works advance reports, periodic monitor by local community	Consultants support, NGO's, local community, gathering and cooperation of lower watershed community
Component C: Disaster prevention and capabilities development education	Number of seminars, trainings, workshops, etc.	Progress reports, local governments and community monitoring	Predisposition of the parties to participate, consultants and NGO's assessments
Project's execution management			
Project's management	Detailed design, work start order, work operation and maintenance supervision	Design plans, work's execution plans, costs estimation, works specifications, works management reports and maintenance manuals	High level consultants and contractors selection, beneficiaries population participation in operation and maintenance

#### 4.14 Baseline for Impact Assessment

The indicators of impact assessment are as shown below.

- Scale of flood discharge

- Inundation area
- Damage caused by flood
- Environment impact
- Operation and maintenance cost

1) Scale of flood discharge

As to the flood which causes the damage, the flood discharge is to be estimated using the rainfall and discharge observation data. Since the probable flood discharges were estimated in each basin in this Study, the occurrence probability of actual flood could be estimated and the impact given by the flood could be assessed.

2) Inundation area

The inundation caused by the actual flood is to be plotted on the topographical map or satellite figure so that the inundation area around flood prevention facilities can be identified. Since the inundation area corresponding to the probable flood was estimated in the this Study, this area can be compared with the actual inundation area and the impact given by the actual inundation can be assessed.

3) Flood damage

The actual flood damage is to be estimated for crops, loss of farm land, irrigation facilities, intake, traffic interruption, and other indirect damage. The actual damage can be compared with the damage caused by the probable flood. The impact caused by the actual damage can be assessed.

4) Environment impact

In the operation and maintenance stage, the environment impact is to be assessed regularly using the same method in this Study. The results are to be compared with the original results, then the environmental impact of the project can be assessed.

5) Operation and maintenance cost

The operation and maintenance cost of the Project was estimated in this Study. The actual O/M cost incurred to the irrigation committee is monitored in every year. The actual cost is to be compared with the estimated and the impact on O/M cost can be assessed.

#### **4.15 Middle and Long Term Plan**

Up to this point, only flood control measures have been proposed and these must be executed most urgently, due to the limitations on the available budget for this Project. However, there are other measures that must be performed in the long term framework. In this section we will be talking about the middle and long term flood control plan.

##### **4.15.1 Flood Control General Plan**

There are several ways to control floods in the entire watershed, for example building dams, reservoirs, dikes or a combination of these.

In case of building a dam proposal, assuming that this dam will reduce the flood peak with a 10 year return period reaching a return period flow of 50 return years, it will be necessary to build a dam with a very big capacity, calculating it in 5.8 million m<sup>3</sup> for Pisco River. Usually upstream of an alluvial area, there is a rough topography in order to build a dam, a very high dam will be required to be built, which implies investing a large amount (more than thousand millions of soles).

Also, it would take between three to five years to identify the dam site, perform geological survey, material assessment and conceptual design. The impact on the local environment is huge. So, it is considered inappropriate to include the dam analysis option in this Study.

Likewise, the option of building a retarding basin would be hardly viable for the same reasons already given for the dam, because it would be necessary to build a great capacity reservoir and it is difficult to find a suitable location because most of the flat lands along the river's downstream are being used for agricultural purposes. So, its analysis has been removed from this Study.

Therefore, we will focus our study in the construction of dike because it is the most viable option.

#### **(1) Plan of the river course**

##### 1) Discharge capacity

An estimation was done on the discharge capacity of the current flow of this river based on longitudinal and cross sectional survey of the river, which results are shown in the section 3.1.10, Figure 3.1.10-3 and Figure 3.1.10-4.

##### 2) Inundation characteristics

The inundation analysis of Pisco river was performed. In the section 3.1.10, Figure 3.1.10-5 and in Figure 3.1.10-6 the inundation condition for flood with probabilities of 50 years is shown.

In the upstream area from 7km from the river mouth, although it overflows around the channel by the shortage of discharge capacity, the flood flow does not spread widely. However, if it overflows in the downstream area from 7km, the flood flow will spread greatly in the left-bank side, and serious damage will be occurred in the Pisco City.

##### 3) Design flood level and dike's standard section

The design flood level was determined in the flood water level with a return period of 50 years applying the standard section of dike already mentioned in section 4.3.1, 5), 3) to the present river channel. In the section 4.2, Table 4.2-2 and Table 4.2-3 the theoretical design flood level and the required height of the dike's crown is shown.

##### 4) Dikes' alignment

Considering the current conditions of existing dikes the alignment of the new dikes was defined. Basically, the broader possible river width was adopted to increase the discharge capacity and the retard effect. In Figure 4.15.1-1 the current channel and the setting alignment method of a section where the current channel has more width is explained schematically. In a normal section, the dike's crown has the same height to the flood water level with a return period of 50 years plus free board,



while in the sections where the river has greater width, double dikes be constructed with inner consistent dike alignment and continuous with normal sections upstream and downstream. The crown height is equal to the flood water level with a return period of 50 years. The external dike's crown height is equal to flood water level with a return period of 50 years, so in case the river overflows the internal dike, the open gap between the two dikes will serve to store sediments and retarding water.

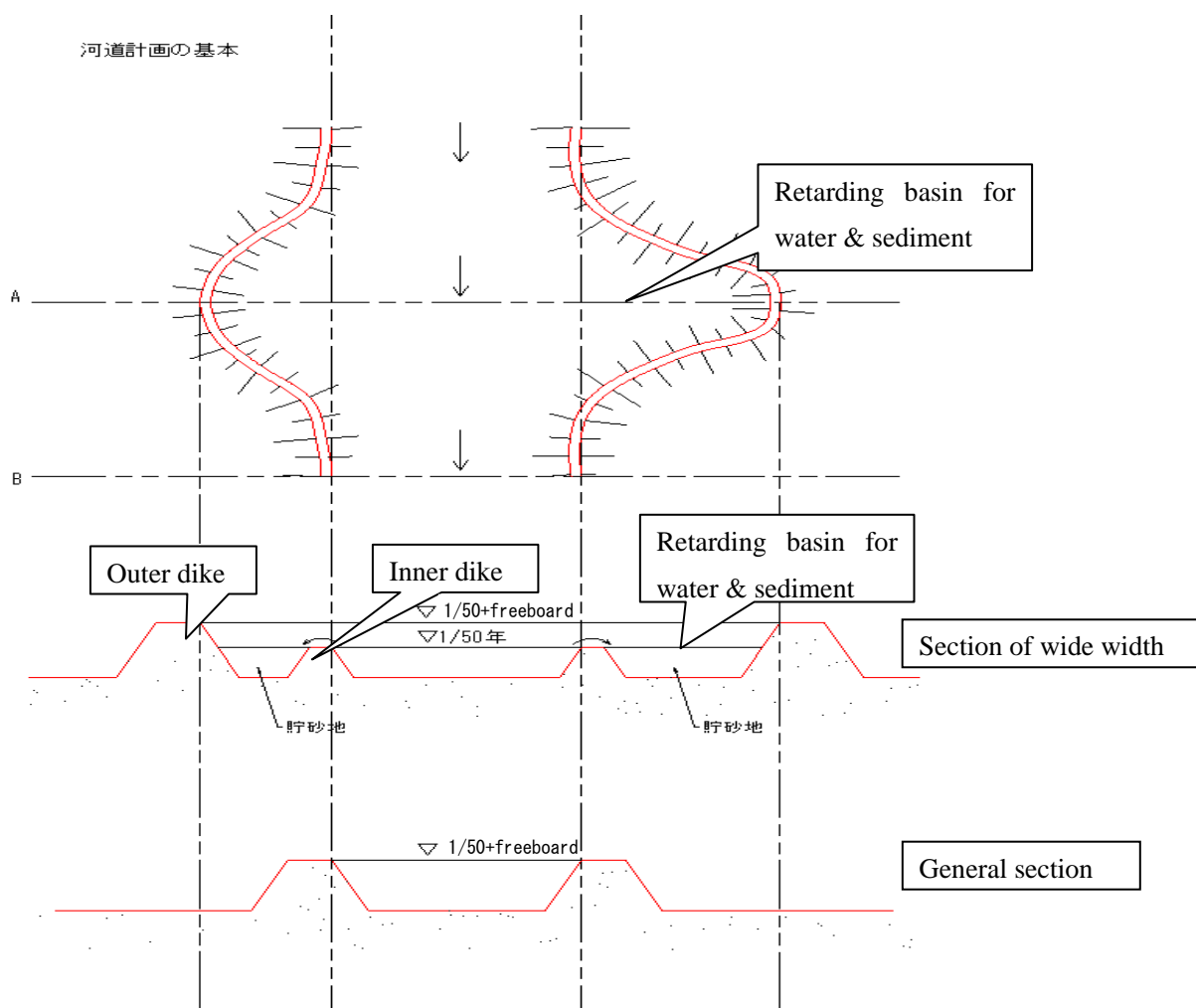

Figure 4.15.1-1 Definition of dike alignment

#### 5) Plan and section of river

The plan and longitudinal section of river are as shown in the Figure 4.15.1-2, and -4.15.1-3 respectively.

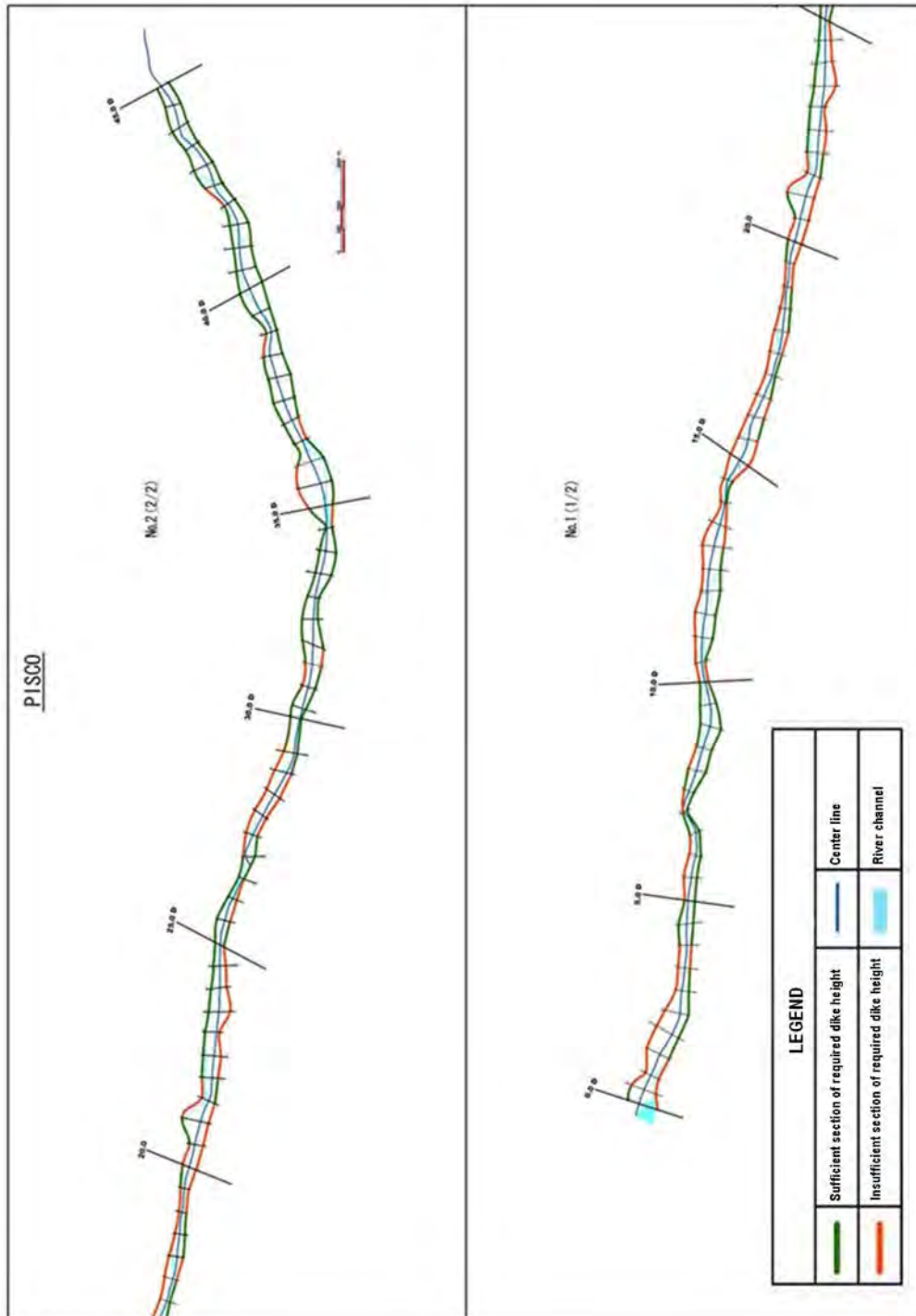

Figure 4.15.1-2 Plan of Pisco river

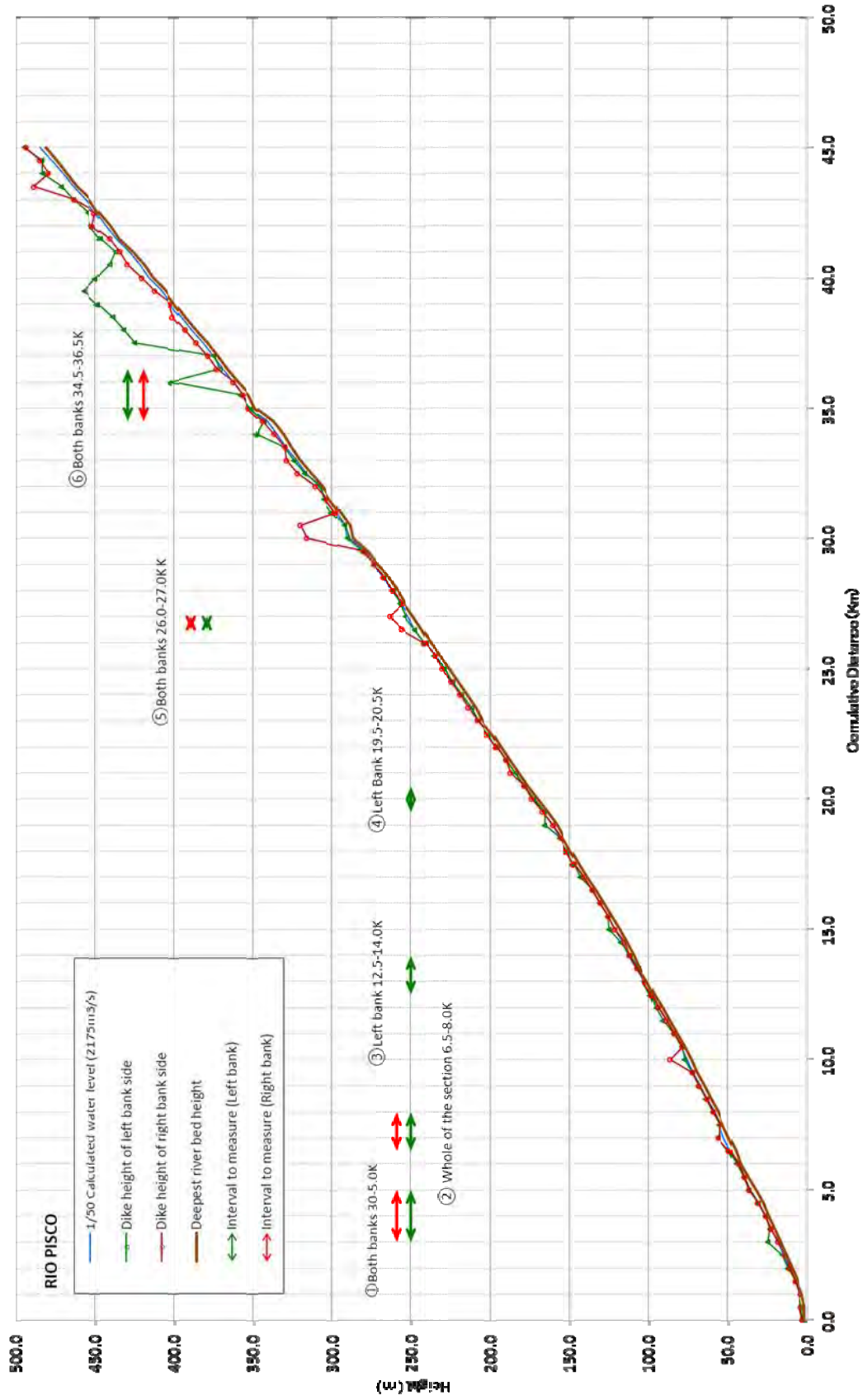

Figure 4.15.1-3 Pisco river longitudinal profile

6) Dike's construction plan

Next, basic policies for the dike's construction plan on the Pisco River are shown:

- Build dikes that allow flood flow safe passage with a return period of 50 years
- The dikes will be constructed in areas where overflowing water will enter the dike, according to the flood simulation
- The dikes will be placed in the sections above mentioned, where the design water level exceeds the existing dike's height or the ground level within the dike
- The dike's height is defined in the flood water level with a return period of 50 years plus the free board

Table 4.15.1-1 and Figure 4.15.1-4 show the dike's construction plan on the Pisco River

**Table 4.15.1-1 Dike's construction plan**

River Name	Improvement Section		Shortage for Design Height (m)	Dike Plan	Dike Length (km)
Pisco River	Left bank side	0.0k-29.0k	0.55	Dike h=1.5m Revetment h=3.0m	14.0
	Right bank side	0.0k-29.5k	0.53		19.5
	Total		0.53		33.5

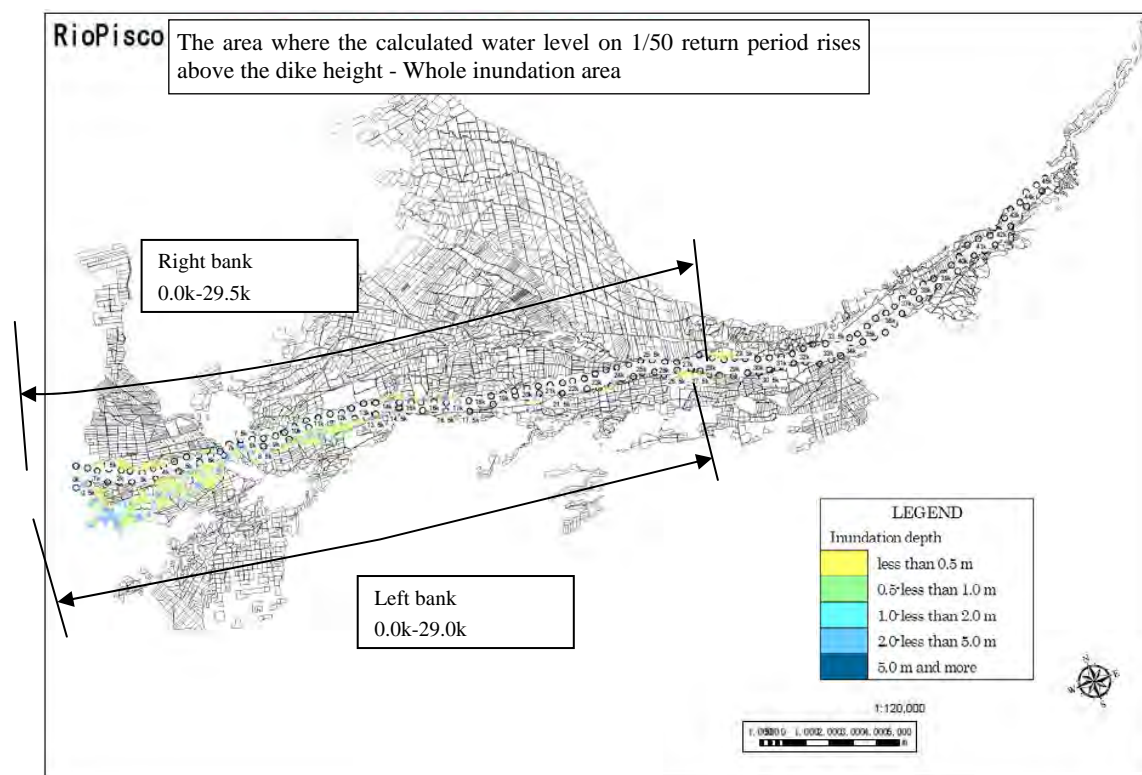

**Figure 4.15.1-4 Layout of dike in Pisco river**

7) Project Cost

In Tables 4.15.1-2 and 4.15.1-3 works' direct costs in private prices and the Project's cost are shown. Also, the cost of the project in social prices is presented in Table 4.15.1-4.

**Table 4.15.1-2 Works direct cost (at private prices)**

Construction of dike				Revetment protection			
B1	H1	B2	A	B1	H2	B2	A
3.0	1.0	8.5	5.8	1.0	1.0	2.4	10.8
3.0	2.0	14.0	17.0	1.0	2.0	2.9	13.4
3.0	3.0	19.5	33.8	1.0	3.0	3.4	16.5
3.0	4.0	25.0	56.0	1.0	4.0	3.9	20.1
3.0	5.0	30.5	83.8	1.0	5.0	4.4	24.3
3.0	1.5	11.3	10.7	1.0	6.0	4.9	28.9
				1.0	1.5	2.6	12.0
				1.0	10.0	6.9	52.4

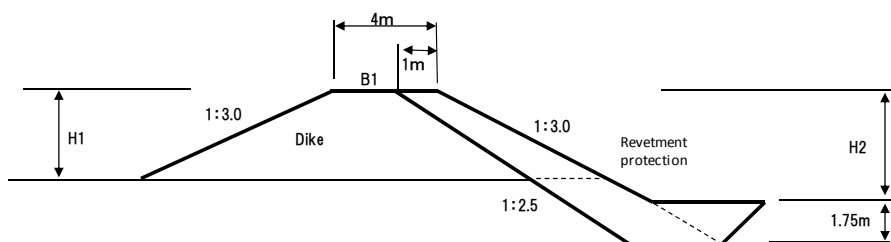

River Basin		Quantity	Unit	Unit Price (Sol)	Direct Construction Cost/ 1m (Sol)	Direct Construction Cost/ 1km (10 <sup>3</sup> Soles)	Dike length (km)	Direct Construction cost (10 <sup>3</sup> Soles)
Pisco	Embankment	10.7	m <sup>3</sup>	10.0	107.0	107.0	33.5	3,584.5
	Revetment	16.5	m <sup>3</sup>	100.0	1,650.0	1,650.0		55,275.0

Table 4.15.1.3 Projects' cost (at private prices)

Basin Name	(Sol)											
	Direct Cost			Indirect Cost						Infrastructure Cost, Total Cost		
	Direct Cost (1)	Temporary Construction Cost (2)	Total Direct Cost (3)=(1)+(2)	Overhead (4)=0.15x(3)	Profit (5)=0.1x(3)	Work Cost (6)=(3)+(4)+(5)	Tax (IGV) (7)=0.18x(6)	Total Construction Cost (8)=(6)+(7)	Environmental Cost (9)=0.01x(8)	Detail Design Cost (10)=0.05x(8)	Construction Supervision Cost (11)=0.1x(8)	Infrastructure Cost, Total Cost (12)=(8)+(9)+(10)+(11)
PIS CO	58,859,500	5,885,950	64,745,450	9,711,818	6,474,545	80,931,813	14,567,726	95,499,539	954,995	4,774,977	9,549,954	110,779,465

Table 4.15.1.4 Projects' cost (at social prices)

Basin Name	(Sol)											
	Direct Cost			Indirect Cost						Infrastructure Cost, Total Cost		
	Direct Cost (1)	Temporary Construction Cost (2)	Total Direct Cost (3)=(1)+(2)	Overhead (4)=0.15x(3)	Profit (5)=0.1x(3)	Work Cost (6)=(3)+(4)+(5)	Tax (IGV) (7)=0.18x(6)	Total Construction Cost (8)=(6)+(7)	Environmental Cost (9)=0.01x(8)	Detail Design Cost (10)=0.05x(8)	Construction Supervision Cost (11)=0.1x(8)	Infrastructure Cost, Total Cost (12)=(8)+(9)+(10)+(11)
PIS CO	47,323,038	4,732,304	52,055,342	7,808,301	5,205,534	65,069,177	11,712,452	76,781,629	767,816	3,839,081	7,678,163	89,066,690

## 2) Operation and maintenance plan

The operation and maintenance cost was calculated identifying the trend of the sedimentation and erosion bed based on the one-dimensional analysis results of the bed variation, and a long-term operation and maintenance plan was created.

The current river course has some narrow sections where there are bridges, farming works (intakes, etc.) and there is a tendency of sediment gathering upstream of these sections. Therefore, in this project there is a suggestion to increase the hydraulic capacity of these narrow sections in order to avoid as possible upstream and in the bed (main part) sedimentation, together with gathering sediments as much as possible when floods over a return period of 50 years occur.

### i) Riverbed fluctuation analysis

The summary of the riverbed fluctuation analysis model is as shown in the Table 4.15.1-5 and the analysis conditions are as shown in the Table 4.15.1-6.

The Figure 4.14.1-6 shows the results of the riverbed fluctuation analysis of the river for the next fifty years. From this figure a projection of the riverbed's sedimentation and scouring trend and its respective volume can be made.

**Table 4.15.1-5 Summary of riverbed fluctuation analysis model**

Items	Content
Water Flow	One-dimensional Non-uniform Flow Model
Sediment Transportation	One-dimensional Mixed Grain Size Riverbed Fluctuation Model
Bed Load	Ashida & Michiue' s Bed load formula
Suspended Load	Ashida & Michiue' s Suspended Load formula considering non-equilibrium of suspended sediment
Calculation Method	MacCormack Method

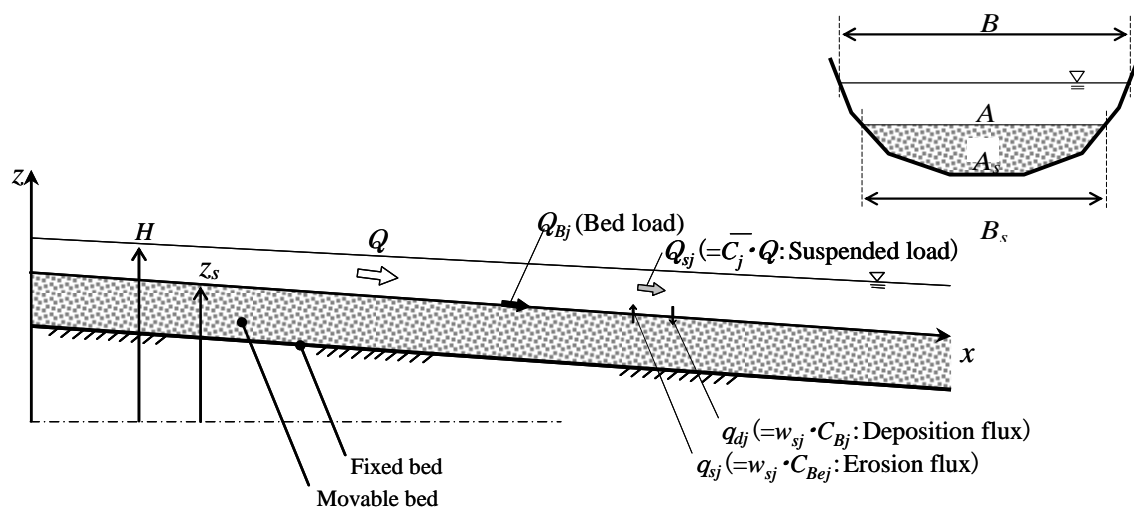

**Figure 4.15.1-5 Pattern diagram of riverbed fluctuation analysis model**

**Table 4.15.1-6 Analysis condition of each river**

	Pisco
Calculation river length	45.0km
Period	For future 50 years
Space interval ( $\Delta x$ )	100m
Time interval ( $\Delta t$ )	2.0sec
Input discharge	50 years discharge prepared based on observation data (max. annual discharge), in case of insufficient year number prepared by repeating the limited year data.
Sediment Supply	173,000m <sup>3</sup> /year
Tributary inflow	Disregarded since there are only small tributaries
Grain size	Based on the grain size distribution in the riverbed material, 8~ 9 grain size are assumed (d=0.075mm ~500mm) .
Water level at downstream end	Assumed normal water depth at the downstream end
Roughness coefficient	n=0.05 (all section)
Void ration	0.4 (representative value of sand and gravel)

ii) Sections that need maintenance

In Table 4.15.1-7 possible sections that require a process of long-term maintenance in the Pisco River watershed is shown.

**Table 4.15.1-7 Sections/places to be carried out maintenance works**

River Name	Excavation Area		Method of Maintenance Works
Pisco River	Place 1	Target Section : 18.0km-20.5km Target Volume : 314,000m <sup>3</sup>	Since the riverbed aggradation advances gradually from now on and flood may be caused, the periodical excavation maintenance should be carried out.
	Place 2	Target Section : 34.0km-35.0km Target Volume : 255,000m <sup>3</sup>	In the section, sediment tends to deposit in the upstream of the existing intake weir. By the periodical excavation in the section, it is thought to be possible to reduce the riverbed aggradation risk in the whole downstream channel.

※Design sediment volume: Sediment volume deposited in 50 years



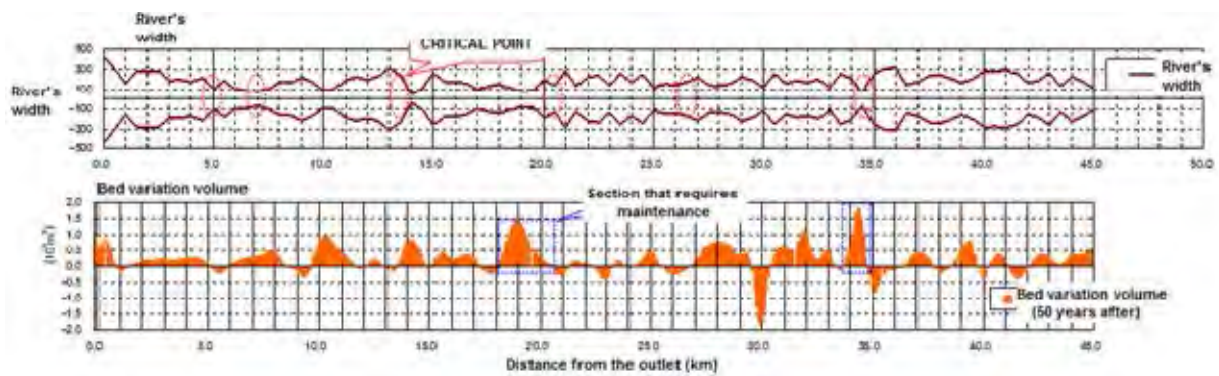

Figure 4.15.1-20 Section that requires maintenance (Pisco river)

### 3) Operation and maintenance cost

Next the direct work cost at private prices for maintenance (bed excavation) required for the watershed in the next 50 years is shown.

#### Direct Work Cost

At private prices:  $569,000 \text{ m}^3 \times 10 = 5,690,000$  soles

Tables 4.15.1-8 and 4.15.1-9 show a 50 year Project cost at private and social prices.

Table 4.15.1-8 Excavation Works cost for a 50 year bed (at private prices)

(million soles)

Basin 流域名	Direct cost 直接工事費計 (1)	Common Temporary Work Cost 共通仮設費 (2) = 0.1*(1)	Construction cost 工事費 (3) = (1) + (2)	Overhead Cost 雑経費 (4) = 0.15*(3)	Profit 利益 (5) = 0.1*(3)	Structure Construction Cost 構造物工事費 (6) = (3)+(4)+(5)	Tax (IGV) 税金 (7) = 0.18*(6)	Construction Cost 建設費 (8) = (6)+(7)	Environment Cost 環境影響 (9) = 0.01*(8)	Detail Design Opst 詳細設計 (10) = 0.05*(8)	Construction Supervision Cost 施工管理費 (11) = 0.1*(8)	Total Project Cost 事業費 (12) = (8)+(9)+(10)+(11)
PISCO	5,690	569	6,259	939	626	7,824	1,408	9,232	92	462	923	10,709

Table 4.15.1-9 Excavation Works cost for a 50 year bed (at social prices)

(million soles)

Basin 流域名	Direct Cost 直接工事費計 (1)	Common Temporary Work Cost 共通仮設費 (2) = 0.1*(1)	Construction Cost 工事費 (3) = (1) + (2)	Overhead Cost 雑経費 (4) = 0.15*(3)	Profit 利益 (5) = 0.1*(3)	Structure Construction Cost 構造物工事費 (6) = (3)+(4)+(5)	Tax (IGV) 税金 (7) = 0.18*(6)	Construction Cost 建設費 (8) = (6)+(7)	Conversion Factor 修正係数 fc (9) = fc*(8)	Construction Cost 建設費 (10) = 0.01*(9)	Environment Cost 環境影響 (11) = 0.05*(9)	Construction Supervision Cost 施工管理費 (12) = 0.1*(9)	Total Project Cost 事業費 (13) = (9)+(10)+(11)+(12)	
PISCO	5,690	569	6,259	939	626	7,824	1,408	9,232	0.804	7,423	74	371	742	8,610

### (3) Social assessment

#### 1) Private prices cost

##### a) Damage amount

Table 4.15.1-10 shows the damage amount calculated analyzing the overflow caused by floods in the Pisco River with return periods between 2 and 50 years.

**Table 4.15.1-10 Amount of damage for floods of different return periods (private prices)**

(10<sup>3</sup> Soles)

Year	Damage Amount
	Pisco
2	16,668
5	23,343
10	50,239
25	59,936
50	81,510
Total	231,698

b) Damage reduction annual average

Table 4.15.1-11 shows the damage reduction annual average of the watershed calculated with the data of Table 4.12.1-10.

c) Project's Cost and the operation and maintenance cost

Table 4.15.1-3 shows the projects' cost. Also, the annual operation and maintenance (O & M) cost for dikes and bank protection works can be observed in the table. This is calculated from the 0.5% of the construction cost plus the bed excavation annual average cost indicated in Table 4.15.1-6.

d) Economic evaluation

In Table 4.15.1-12 the results of economic assessment are shown.

**Table 4.12.1-11 Damage reduction annual average**

(10<sup>6</sup> Soles)

Basin	Return Period	Probability	Total Damage			Average Damage ④	Section Probability ⑤	Annual Average Damage ⑥=④×⑤	Accumulation of Annual Average Damage
			Without Project ①	With Project ②	Damage Reduction ③=①-②				
PISCO	1	1.000	0	0	0			0	0
	2	0.500	16,668	0	16,668	8,334	0.500	4,167	4,167
	5	0.200	23,343	0	23,343	20,006	0.300	6,002	10,169
	10	0.100	50,239	0	50,239	36,791	0.100	3,679	13,848
	25	0.040	59,936	0	59,936	55,088	0.060	3,305	17,153
	50	0.020	81,510	0	81,510	70,723	0.020	1,414	18,568

**Table 4.15.1-12 Economic assessment results (private prices costs)**

流域名	年平均被害軽減額	評価期間被害軽減額(15年)	事業費	維持管理費	B/C	NPV	IRR(%)
Basin	Annual Average Damage Reduction	Damage Reduction in Evaluation Period(15years)	Project Cost	O&M Cost	Cost Benefit Ration	Net Present Value	Internal Return of Rate
Pisco	241,380,602	109,002,695	110,779,465	9,420,215	1.08	7,808,090	11%

2) Social prices cost

a) Damage amount

Table 4.15.1-13 shows the damage amount calculated analyzing the overflow caused by floods in the Majes-Camana River with return periods between 2 and 50 years in each watershed.

**Table 4.15.1-13 Amount of damage for floods of different return periods (at social prices)**

(10<sup>3</sup> Soles)

Year	Damage Amount
	Pisco
2	17,099
5	22,817
10	54,702
25	64,250
50	87,899
Total	246,768

b) Damage reduction annual average

Table 4.15.1-14 shows the damage reduction annual average of each watershed calculated with the data of Table 4.15.1-13.

c) Project's Cost and the operation and maintenance cost

Table 4.15.1-4 shows the projects' cost. Also, the annual operation and maintenance (O & M) cost for dikes and margin protection works can be observed in the table. This is calculated from the 0.5% of the construction cost, as well as the bed excavation annual average cost indicated in Table 4.15.1-7.

d) Economic evaluation

In Table 4.15.1-15 the results of economic assessment are shown.

(4) Conclusions

The economic assessment result shows that the Project has positive economic impact in terms of cost on both private and social prices, but the required cost is extremely high (89.1 million soles), so that this Project is less viable to be adopted.

**Table 4.15.1-14 Damage reduction annual average**

(10<sup>6</sup> Soles)

Basin	Return Period	Probability	Total Damage			Average Damage ④	Section Probability ⑤	Annual Average Damage ⑥=④×⑤	Accumulation of Annual Average Damage
			Without Project ①	With Project ②	Damage Reduction ③=①-②				
PISCO	1	1.000	0	0	0		0	0	
	2	0.500	17,099	0	16,302	8,549	0.500	4,275	4,275
	5	0.200	22,817	0	16,302	19,958	0.300	5,987	10,262
	10	0.100	54,702	0	16,302	38,760	0.100	3,876	14,138
	25	0.040	64,250	0	16,302	59,476	0.060	3,569	17,706
	50	0.020	87,899	0	16,302	76,075	0.020	1,522	19,228

**Table 4.15.1-15 Economic assessment results (social prices costs)**

流域名	年平均被害軽減額	評価期間被害軽減額(15年)	事業費	維持管理費	B/C	NPV	IRR(%)
Basin	Annual Average Damage Reduction	Damage Reduction in Evaluation Period(15years)	Project Cost	O&M Cost	Cost Benefit Ration	Net Present Value	Internal Return of Rate
Pisco	249,965,955	112,879,671	89,066,690	7,573,853	1.39	31,519,208	16%

#### 4.15.2 Reforestation and Recovery of Vegetation Plan

Long-term reforestation in all areas considered to be critical of the upper watershed is recommended. So, a detail analysis of this alternative will be explained next.

##### 1) Basic policies

- Objectives: Improve the water source area's infiltration capacity, reduce surface soils, water flow and at the same time, increase water flow in intermediate soils and ground-water level. Because of the above mentioned, water flow is interrupted in high flood season, this increases water resources in mountain areas, reduces and prevents floods increasing with it the amount and greater flow of ground-water level, reducing and preventing floods
- Forestry area: means forestry in areas with planting possibilities around watersheds with water sources or in areas where forest area has decreased.
- Forestry method: local people plantations. Maintenance is done by promoters, supervision and advisory is led by NGOs.
- Maintenance after forestry: Maintenance is performed by the sow responsible in the community. For this, a payment system (Payment for Environmental Services) will be created by downstream beneficiaries.
- Observations: After each thinning the area will have to be reforested, keeping and preserving it in a long-term sustainable way. An incentive for community people living upstream of the watershed shall be designed.

The forest is preserved after keeping and reforesting it after thinning, this also helps in the support and prevention of floods. For this, it is necessary that local people are aware, encourage people downstream, promote and spread the importance of forests in Peru during the project's execution.

##### 2) Selection of forestry area

As mentioned in 1) forestry of the upper watershed will be done with the help of the communities' labor, during their spare time from their agricultural activities. However, the community mostly lives in the highlands performing their farming and cattle activities in harsh natural conditions. Therefore, it is difficult to tell if they have the availability to perform forestry. So, finding comprehension and consensus of the inhabitants will take a long time.

3) Time required for the reforestation project

Since it is a small population, the workforce availability is reduced. So, the work that can be carried out during the day is limited, and the work efficiency would be very low. The JICA Study Team estimated the time required to reforest the entire area throughout the population in the areas within the reforestation plan, plant quantity, work efficiency, etc. According to this estimate, it will take 17 years to reforest approximately 54,000 hectares of Pisco River Watershed.

4) Total reforestation volume in the upper watershed and project's period and cost

The surface to be reforested for the Pisco River Watershed is a vast area (approx. 54,000 ha), in years (17 years) and in investment amount (145.06million soles).

**Table 4.15.2-1 Upstream Watershed Forest General Plan**

Watershed	Forestry Area (ha)	Required period for the project (years)	Required budget (soles)
Pisco	53,933.75	17	145,574,401

(Source: JICA Study Team)

5) Conclusions

The objective of this project is to execute the most urgent works and give such a long period for reforestation which has an indirect effect with an impact that takes a long time to appear would not be consistent with the proposed objective for the Project. Considering that 17 years and invested 145.6 million soles are required, we can say that it is impractical to implement this alternative in this project and that it shall be timely executed within the framework of a long-term plan after finishing this project.

**4.15.3 Sediment Control Plan**

For the long-term sediment control plan, it is recommended to execute the necessary works in the upper watershed.

The Sediment Control Plan in the upper watershed will mainly consist in construction of sediment control dikes and margin protection works. In Figure 4.15.3-1 the sediment control works disposition proposed to be executed throughout the watershed is shown. The cost of Pisco River works was estimated focusing on: a) covers the entire watershed, and b) covers only the priority areas, analyzing the disposition of works for each case (refer to Annex-6 Sediment Control Plan, 2.3). The results are shown in Table 4.15.3-1.

Due to the Pisco River extension, the construction cost for every alternative would be too high in case of carrying-out the margin protection works, erosion control dikes, etc. Apart from requiring a considerably long time. This implies that the project will take a long time to show positive results. So, it is decided that it is impractical to execute this alternative within this project and should be timely executed within the framework of a long-term plan, after finishing this project.

**Table 4.15.3-1 Upper watershed sediment control works execution estimated costs**

Watershed	Approach	Bank Protection		Strip		Sediment control dike		Total works direct cost	Project Cost (Millions S/.)
		Vol. (km)	Direct Cost (Million S/.)	Vol. (units)	Direct Cost (Million S/.)	Vol. (units)	Direct Cost (Million S/.)		
Pisco	All Watershed	269	S/.287	27	S/.1	178	S/.209	S/.497	S/.935
	Prioritized Section	269	S/.287	27	S/.1	106	S/.126	S/.414	S/.779

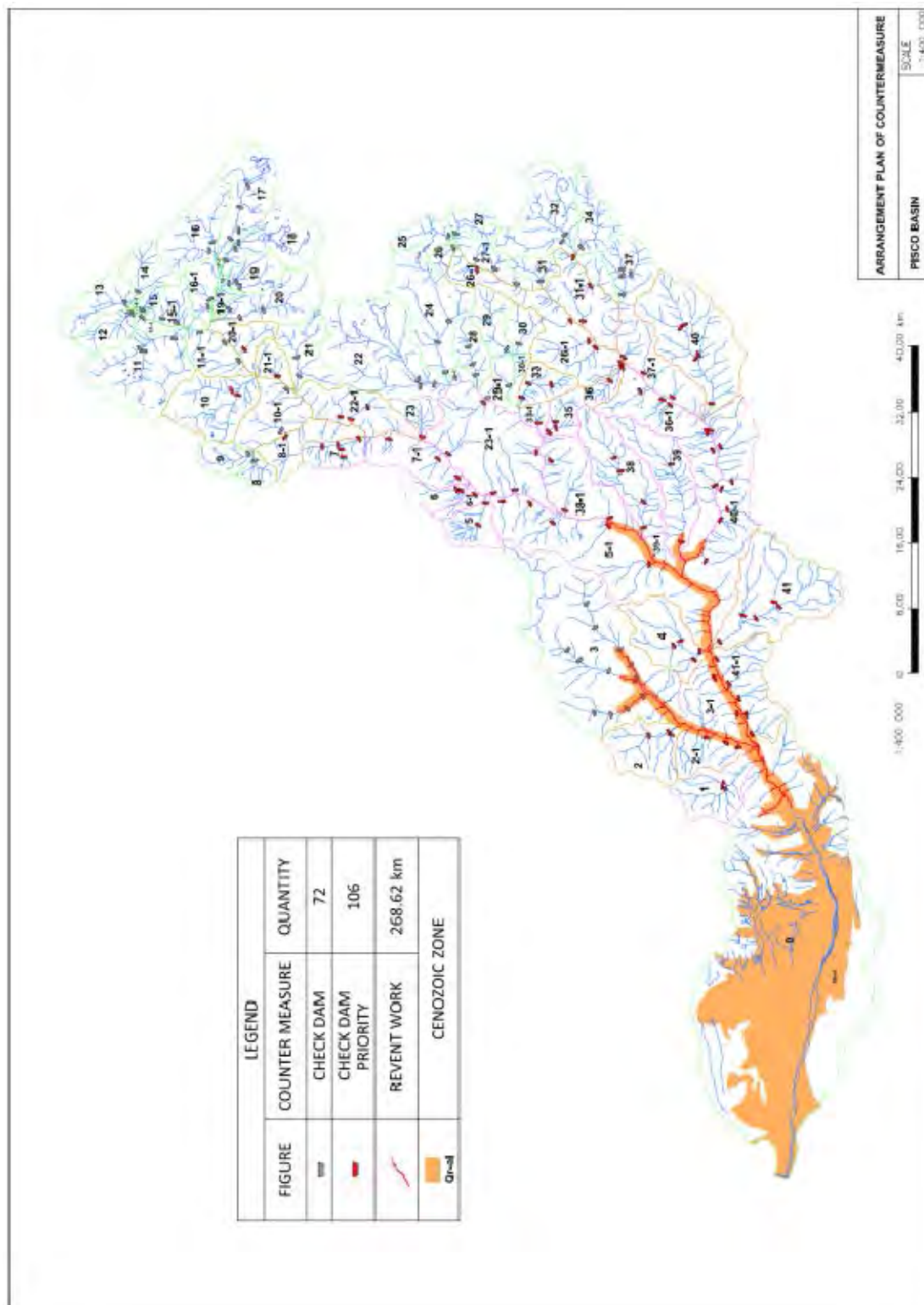

Figure 4.15.3-1 Sediment control works location Pisco river watershed





## **5. CONCLUSION AND RECOMMENDATION**

### **5.1 Conclusion**

The flood prevention facilities selected finally in this Project are safe in structural, and have high viability and give scarcely impact to the environment. It is concluded that the Project should be implemented as soon as possible so that the high vulnerability against flood in valleys (Valles) and rural communities could be reduced and the social economic development will be promoted in the Project area.

### **5.2 Recommendation**

Based on the knowledge and experience obtained from this Study, the following recommendations are presented on the implementation of this Project and the future flood control measures in Peru.

#### **5.2.1 Recommendation on Implementation of This Project**

##### **(1) Problems to be solved at present**

1) The project cost will be covered by the central government (through the DGIH), regional governments and irrigation committees.

The sharing ratio among stakeholders is assumed provisionally 80% for the central government (in this case MINAG), 15% for regional government and 5% for irrigation committee. Since the total cost of this Project was determined in the Feasibility Study, the final ratio will be determined through negotiation among 3 parties as soon as possible.

2) The area to be occupied by the flood prevention facilities and the plantation along river was determined in this study. It is recommended that the Project holder (DGIH) should define the limit of river area with private land and continually should carry on the process of land acquisition based on the Land Acquisition Law, which are; Emission of Resolution for land acquisition by the State, Proposition of land cost and compensation for land owner, Agreement of the State and land owner, Payment etc.

3) Confirmation of implementation agency of the Project

The implementation agency is assumed to be PSI, MINAG, however DGPI, MEF and OPI, MINAG do not always agree that, so that the final implementation agency will be determined as soon as possible.

4) As to the environment impact assessment of this Project, DGAA, MINAG evaluated the Initial Environment Assessment (EAP) of the Project and classified this Project in to Category I so that the additional environment assessment is not required, however it is necessary to proceed the process of preservation of archeological heritage.

5) Acquisition of CIRA (Certificación de Inexistente de Restos Arqueológicos) DGIH has to

promote the process to obtain the CIRA in the detail design stage. The process to be taken is i) Application form, ii) Copies of the location drawings and outline drawings, iii) voucher, iv) Archaeological Assessment Certificate.

6) The operation and maintenance after implementation of the Project will be carried out by the irrigation committee. They are not familiar the flood prevention facilities which are different type of structure from the agricultural facilities such as irrigation channel, intake and so on, so that that the technical and economic assistance by MINAG and local government

## **(2) Structural measures**

### 1) Basic policy of flood control

In the basic policy of flood control, the flood prevention measures should be prepared gradually from the downstream to the upstream of river. However the facilities with high priority such as wide inundation area and giving serious impact on the socio-economy of the region were selected and planned to be implemented in this Project.

Once the preparation in the upstream area is completed, of which influence occurs in the opposite bank or downstream area. And the asset will be accumulated by preparation of flood prevention measures which means the increase of damage potential, if the flood over design flood will occur the damage might be enlarged more than before due to increase of damage potential. Therefore it could not be said that the damage will be not always decreased, which should be noticed to people and the land use regulation should be prepared.

### 2) Problems for flood control planning in Pisco river

At the section from the river mouth to 7km upstream, the water inundates farmland nearby due to lack of discharge capacity, but not extending beyond. However, when the inundation occurs in the lower reach (from the mouth to 7 km), the water inundates large areas of the left bank causing serious damage in urban areas of Pisco. Therefore at the downstream section from 7km, the embankment is executed in the section with highest risk of inundation and at the upstream area countermeasures in the sections with low discharge capacity such as bridges and intake.

At the Pan-American road the river width is narrowed, so that the widening the river width with building new bridge is considered, however taking account of the large traffic volume, necessity of access road to the bridge causing large cost, and that DGIH judged that the construction of new bridge is difficult for demarcation of administrative responsibility among Ministries, the construction of new bridge is not adopted in this Project.

The sections with high priority are selected as described above, even when the facility in each section is complete it cannot be said that the preparation of whole Pisco river is completed. In future the sections where discharge capacity is not enough and need the strengthening dike will be continuously prepared for flood control. In addition to that the bridges at narrow sections should be rebuilt with cooperation of road department. And the inundation area of Pisco river includes the urban area of Pisco city. There is possibility that the floods over the design flood will occur so that

the minimization measures of flood damage such as the non- structural measures for flood forecasting and warning and secure of evacuation road should be promoted.

### 3) Problems in design and construction work

#### i) Construction work period

The dry season in the study area is from May to November when the level of water is very low or the river dries up, however the possible construction period is desirable to be from April to December considering the transition period from season to season.

The river characteristics / features should be taken into account, that is, Pisco Rivers is seasonal river. At the same time, the crop season cycle in the areas of direct influence should be taken into account, so that traffic jams caused by the large trucks and farming machinery is prevented.

#### ii) Safety of dike

Dikes will be made of material available in the zone (river bed or banks). In this case, the material would be sand and gravel or sandy soil with gravel, of high permeability. The stability problems forecasted in this case are as follows.

- Infiltrate destruction caused by piping due to washing away fine material
- Sliding destruction of slope due to infiltrate pressure

In order to secure the stability of dike the appropriate standard section should be determined by infiltration analysis and stability analysis for sliding based on unit weight, strength and permeability of embankment material.

The importance in dike construction is sufficient compaction of dike material. The cost estimate standard in Peru the compaction is to be made by tractor; however for the sufficient compaction it is desirable to use compaction equipment such as vibration roller etc.

And in order to supervise the compaction of material, the density test and grain size analysis are important, of which are specified in the technical specification of the tender document (refer to Annex-9 Construction Planning/Cost Estimate, 3.3 Cost Estimate of Direct Cost, Item 2.2 Survey and Quality Control of Integrated List).

#### iii) Reduction of bank protection cost

The cost of construction work for the revetment occupies over 80% of the direct cost of the project in the embankment section. Moreover, the conveyance cost for the rocks from quarry site occupies 45% of the revetment works. In the places where existing revetment works and groin works still remain it should be considered that reusing of materials leads to reduction of construction costs.

#### iv) Balance of banking and excavation volume

As for balance of earth volume for embankment and excavation, there are shortages earth materials for embankment with 203,000m<sup>3</sup> in the Pisco River. Since the land along the river is used for farmland, the earth materials for embankment shall be taken from riverbed material. In case of excavation in riverbed for making flow capacity increase, there is a possibility that dike

height will be lower a little. On the other hand, there is a possibility for promoting riverbed scouring due to steep slope of river. In the detail design phase, the selection of adequate places for borrow pits shall be important.

### **(3) Non-structural measures**

#### 1) Afforestation

The afforestation and vegetation recovery plan is divided into i) short term plan and ii) long term plan (upstream area in the river), among which the short term plan is adopted in this Project. In future flood control plan it is necessary that the long term plan will be executed; however the long term plan requires enormous project period and project cost. Therefore it is recommended that the long term plan will be realized by the effort of securing budget step by step.

#### 2) Sediment control and riverbed fluctuation

##### i) Sediment control plan

Cost for sediment control plan in the mountainous area is expensive (935 million soles), in addition project need long term periods. There are no objects to be conserved in the mountainous area, so cost-benefit performance is low. Main purpose in this project is mitigation of the flood disaster. With the view to this purpose, it is judged that sediment control works in the alluvial fans is most effective. It is judged that implementation of the river structures that have the functions of sediment control in Pisco basin that has a profound effect of the sedimentation would be most effective.

Despite being distinct from the project purpose, in Peru sediment disasters have occurred frequently. So Non-structural measures to mitigate the sediment disasters would be suggested as shown below. These Non-structural measures are more economical than structural measures and have function to prevent the human life and minimum property from the sediment disaster.

- Regulation of agricultural areas and residential areas
- Setting the alert rainfall for each region and establishment early warning Systems.
- Collect sample of sediment disaster and raise awareness of disaster prevention through education and patrimony of disaster prevention

##### ii) Riverbed fluctuation

The results of field investigation and riverbed fluctuation analysis show no urgent necessity of sediment control measures in all rivers. However from the long term point of view the decrease of riverbed elevation is forecasted in the Cañete river upstream of which the dam is located and increase of riverbed elevation by the unstable sediment run-off in Majes-Camana river upstream of which no sediment control facilities exist so that the flood control function is reduced. And it is important that the effect of the facilities is confirmed in Chincha and Pisco rivers upstream of which the sediment control facilities planned,.

From now on the monitoring system for topography of river channel and local scouring should be established in all rivers depending on the riverbed fluctuation characteristics, and the

accumulation of such basic data is required.

#### **(4) Disaster prevention education/capacity development**

##### 1) Soft counter measures for reduction of flood damage

The design flood discharge in this Study is a flood with return period of 50 years which is calculated based on the past rainfall observation data. However the flood over design flood may occur due to El Niño or extraordinary meteorological phenomena. Since the forecasting of such floods is difficult it is impossible to prepare for such floods by hard counter measures. Since there is still risk for such floods, the establishment of soft countermeasures such as flood defense work, evacuation, preparation of hazard map and the notification and education to people is required.

##### 2) Promotion of community disaster prevention

It is important to promote the community disaster prevention, which reinforces the effect of this Project and induces the local people participation to the Project. The long time approach and activities are required until that the self and mutual assistance is motivated and the people start voluntarily concrete activities as a first step of activation of voluntary disaster prevention organization.

It is necessary that the irrigation committee builds the community disaster prevention system as a core based on the disaster prevention education in this Project in order to increase the effect of the Project

### **5.2.2 Recommendation for Future Flood Control Plan in Peru**

#### **(1) Preparation of comprehensive master plan for flood control**

There are almost no flood prevention facilities in the Study area although the dikes are built in some places. The flood prevention facilities constructed in this Project are also partly, however they cover the important points and give the high economic effect as seen in the social evaluation results so that it can be said very significant project.

However, as to the future flood control in Peru, the integral master plan for major basins should be established and implemented step by step for objectives of not only agricultural facilities but also urban areas, roads, bridges etc.

#### **(2) Establishment of implementation agency for integral flood control project**

The counterpart ministry of this Project is MINAG which is responsible for the agricultural sector so that they cannot easily implement the disaster prevention project belong to the other sector.

In order to realize the above (1) it is necessary that the role of the existing agency will be change to be able to implement the flood control plan with integral purpose or establishment of new agency. By such agency the integral flood prevention measures and operation and maintenance of river such as

dike, bank protection, groin, erosion of river bank, sedimentation in riverbed, intake weir etc. should be carried out completely.

### **(3) Execution of strict river management**

The boundary of river area and private land is not clear, the river area is used sometimes as agricultural land, and the garbage is dumped in the river area illegally, which means the administration of river area is not well performed. Therefore the preparation of river law system and strict application of it is quite required.

### **(4) Establishment of nationwide network of rainfall and discharge observation stations**

The estimation of flood discharge and flood pattern is indispensable as basic data for establishment of flood control plan. In order to estimate the above data with appropriate accuracy, the rainfall observation stations with enough density in the basin and the discharge observation stations at important points along the river are necessary as well as hourly observation data. And in order to estimate the flood discharge and flood pattern, the hourly data is indispensable.

However the data to be used in the Study area is very limited, for example, in the Yauca basin with area of 4,312km<sup>2</sup> there are 7 rainfall stations, of which only one station (Cora Cora2) is under operation. The observation data is all daily base for rainfall and discharge and is not hourly base

To promote the flood control in Peru, the establishment of network of rainfall and observation stations is indispensable. To do so, it is necessary that the master plan of observation network covering all Peru is to be established and the base stations are selected and the observation is carried out. The followings are to be examined to make the master plan and to select the basic stations.

- \* Review of observation data of existing stations
- \* Select observation stations to be used and digitalize of available data
- \* Plan of observation network and classification of planned and existing stations depending on importance
- \* Renewal of observation equipment in the existing stations depending on importance
- \* Installation new basic stations
- \* Plan of transmission system of data
- \* Plan of recording and keeping system of observation data
- \* Plan of operation and maintenance system
- \* Trial observation at the stations above

In implementation of above project, the all Peru is divided into several areas depending on the importance, then the project will be implemented step by step, and the implementation might be done by the assistance of foreign country

The administration of observation data is performed by SENAMHI at present, the observation data will be opened regularly to the public and can be used widely by the utilizer.