

**Ministry of Agriculture
Republic of Peru**

**THE PREPARATORY STUDY
ON
PROJECT OF THE PROTECTION OF
FLOOD PLAIN AND VULNERABLE RURAL
POPULATION AGAINST FLOOD IN THE
REPUBLIC OF PERU**

**FINAL REPORT
MAINREPORT
I-3 PROJECT REPORT
(CHINCHA RIVER)**

March 2013

**JAPAN INTERNATIONAL COOPERATION AGENCY
(JICA)**

**YACHIYO ENGINEERING CO., LTD.
NIPPON KOEI CO., LTD.
NIPPON KOEI LATIN AMERICA –
CARIBBEAN Co., LTD.**

GE
CR (4)
13-090

Composition of Final Report

I. Feasibility Study Report

I-1 Program Report

I-2 Project Report (Cañete River)

I-3 Project Report (Chincha River) (This Report)

I-4 Project Report (Pisco River)

I-5 Project Report (Majes-Camana River)

I-6 Supporting Report

Annex – 1 Metrology /Hydrology /Run-off Analysis

Annex – 2 Inundation Analysis

Annex – 3 River Bed Fluctuation Analysis

Annex – 4 Flood Control Plan

Annex – 5 Forecasting and Warning System in Chira River

Annex – 6 Sediment Control

Annex – 7 Afforestation and Vegetation Recovery Plan

Annex – 8 Plan and Design of Facilities

Annex – 9 Construction Planning and Cost Estimate

Annex – 10 Socio-economy and Economic Evaluation

Annex – 11 Environmental and Social Considerations/ Gender

Annex – 12 Technical Assistance

Annex – 13 Stakeholders Meetings

Annex – 14 Implementation Program of Japanese Yen Loan Project

Annex – 15 Drawings

I-7 Data Book

II. Pre- Feasibility Study Report

II-1 Program Report

II-2 Project Report (Chira River)

II-3 Project Report (Cañete River)

II-4 Project Report (Chincha River)

II-5 Project Report (Pisco River)

II-6 Project Report (Yauca River)

II-7 Project Report (Majes-Camana River River)



Study Area Map

Abbreviation

Abbreviation	Official Name or meaning
ANA	Autoridad Nacional del Agua(Water National Authority)
ALA	Autoridad Local del Agua(Water Local Authority)
B/C	Cost-Benefit Ratio(Cost-Benefit relation)
GDP(PBI)	Producto Bruto Interno(PBI)(Gross Domestic Product)
GIS	Sistema de información geográfica (Geographic Information System)
DGAA	Dirección General de Asuntos Ambientales(Environmental Affairs General Direction)
DGFFS	Dirección General de Forestal y de Fauna Silvestre (Forestry and Fauna General Direction)
DGIH	Dirección General de Infraestructura Hidráulica (Hydraulic Infrastructure General Direction)
DGPI(previous DGPM)	Dirección General de Política de Inversiones (Investment Policy General Direction), (Dirección General de Programación Multianual del Sector Público)(Public Sector Multiannual Program General Direction)
DGETP(previous DNEP)	Dirección General de Endeudamiento y Tesoro Público (Public Indebtedness National Direction), Dirección Nacional de Endeudamiento Público
DRA	Dirección Regional de Agricultura (Agriculture Regional Direction)
EIA	Estudio de impacto ambiental (Environmental Impact Assessment - EIA)
FAO	Organización de las Naciones Unidas para la Agricultura y la Alimentación (Food and Agriculture Organization of the United Nations)
F/S	Estudio de Factibilidad (Feasibility Study)
GORE	Gobiernos Regionales (Regional Governments)
HEC-HMS	Sistema de Modelado Hidrológico del Centro de Ingeniería Hidrológica (Hydrologic Model System from the Hydrology Engineer Center)
HEC-RAS	Sistema de Análisis de Ríos del Centro de Ingeniería Hidrológica (Hydrologic Engineering Centers River Analysis System)
IGN	Instituto Geográfico Nacional (National Geographic Institute)
IGV	Impuesto General a Ventas (TAX)
INDECI	Instituto Nacional de Defensa Civil (Civil defense National Institute)
INEI	Instituto Nacional de Estadística (Statistics National Institute)
INGEMMET	Instituto Nacional Geológico Minero Metalúrgico (Metallurgic Mining Geologic National Institute)
INRENA	Instituto Nacional de Recursos Naturales (Natural Resources National Institute)
IRR	Tasa Interna de Retorno (Internal Rate of Return - IRR)
JICA	Agencia de Cooperación Internacional del Japón (Japan International Cooperation Agency)
JNUDRP	Junta Nacional de Usuarios de los Distritos de Riego del Perú (Peruvian Irrigation District Users National Board)
L/A	Acuerdo de Préstamo (Loan Agreement)
MEF	Ministerio de Economía y Finanzas (Economy and Finance Ministry)
MINAG	Ministerio de Agricultura (Agriculture Ministry)

M/M	Minuta de Discusiones (Minutes of Meeting)
NPV	VAN (Valor Actual Neto) (NET PRESENT VALUE)
O&M	Operación y mantenimiento (Operation and maintenance)
OGA	Oficina General de Administración (Administration General Office)
ONERRN	Oficina Nacional de Evaluación de Recursos Naturales (Natural Resources Assessment National Office)
OPI	Oficina de Programación e Inversiones (Programming and Investment Office)
PE	Proyecto Especial Chira-Piura (Chira-Piura Special Project)
PES	PSA (Pago por Servicios ambientales) (Payment for Environmental Services)
PERFIL	Estudio del Perfil (Profile Study)
Pre F/S	Estudio de prefactibilidad (Pre-feasibility Study)
PERPEC	Programa de Encauzamiento de Ríos y protección de Estructura de Captación (River Channeling and Protection of Collection Structures Program)
PRONAMACHIS	Programa Nacional de Manejo de Cuencas Hidrográficas y Conservación de Suelos (Water Basins Management and Soil Conservation National Program)
PSI	Programa Sub Sectorial de irrigaciones (Sub-Sectorial Irrigation Program)
SCF	Factor de conversión estándar (Standard Conversion Factor)
SENAMHI	Servicio Nacional de Meteorología y Hidrología (Meteorology and Hydrology National Service)
SNIP	Sistema Nacional de Inversión Pública (Public Investment National System)
UE	Unidad Ejectora(Execution Units)
UF	Unidades Formuladoras (Formulator Units)
VALLE	Llanura aluvial, llanura de valle (Alluvial Plain, Valley Plain)
VAT	Impuesto al valor agregado (Value added tax)

THE PREPARATORY STUDY
ON
PROJECT OF THE PROTECTION OF FLOOD PLAIN AND VULNERABLE RURAL
POPULATION AGAINST FLOODS IN THE REPUBLIC OF PERU
FINAL REPORT
I-3 MAIN REPORT
PROJECT REPORT
(CHINCHA RIVER)

Table of Contents

Location Map

Abbreviation

1. EXECUTIVE SUMMARY	1-1
1.1 Project Name	1-1
1.2 Project's Objective	1-1
1.3 Supply and Demand Balance.....	1-1
1.4 Technical Proposal	1-2
1.4 .1 Structural Measures	1-2
1.4.2 Non-Structural Measures	1-3
1.4.3 Technical Support.....	1-4
1.5 Costs	1-5
1.6 Social Assessment	1-5
1.7 Sustainability Analysis	1-6
1.8 Environmental Impact	1-7
1.9 Institutions and Management.....	1-8
1.10 Execution Plan.....	1-9
1.11 Financial Planning.....	1-10
1.12 Conclusion and Recommendation	1-11
1.12.1 Conclusion	1-11
1.12.2 Recommendation	1-11
1.13 Logical Framework.....	1-12
1.14 Middle and Long Term Plans	1-13
2. GENERAL ASPECTS.....	2-1
2.1 Name of the Project	2-1
2.2 Formulator and Executor Units	2-1
2.3 Involved entities and Beneficiaries Participation	2-1
2.4 Framework.....	2-4
2.4.1 Background.....	2-4
2.4.2 Laws, Regulations, Policies and Guidelines Related to the Program	2-7

3. IDENTIFICATION	3-1
3.1 Diagnosis of the Current Situation	3-1
3.1.1 Nature	3-1
3.1.2 Socio-Economic Conditions of the Study Area	3-2
3.1.3 Agriculture	3-7
3.1.4 Infrastructure	3-11
3.1.5 Real Flood Damages	3-13
3.1.6 Results on the Visits to Study Sites	3-14
3.1.7 Current Situation of Vegetation and Reforestation	3-20
3.1.8 Current Situation of the Soil Erosion	3-23
3.1.9 Run-off Analysis	3-34
3.1.10 Analysis of Inundation	3-58
3.2 Definition of Problem and Causes	3-65
3.2.1 Problems of Flood Control Measures in the Study Area	3-65
3.2.2 Problem Causes	3-65
3.2.3 Problem Effects	3-66
3.2.4 Causes and Effects Diagram	3-66
3.3 Objective of the Project	3-68
3.3.1 Solving Measures for the Main Problem	3-68
3.3.2 Expected Impacts for the Main's Objective Fulfillment	3-68
3.3.3 Measures - Objectives – Impacts Diagram	3-69
4. FORMULATION AND EVALUATION	4-1
4.1 Definition of the Assessment Horizon of the Project	4-1
4.2 Supply and Demand Analysis	4-1
4.3 Technical Planning	4-4
4.3.1 Structural Measures	4-4
4.3.2 Nonstructural Measures	4-19
4.3.3 Technical Assistance	4-27
4.4 Costs	4-33
4.4.1 Cost Estimate (at Private Prices)	4-33
4.4.2 Cost Estimate (at Social Price)	4-52
4.5 Social Assessment	4-54
4.5.1 Private Prices Costs	4-54
4.5.2 Social Prices Costs	4-62
4.6 Sensitivity Analysis	4-64
4.8 Sustainability Analysis	4-67
4.9 Environmental Impact	4-69
4.9.1 Procedure of Environmental Impact Assessment	4-69
4.9.2 Methodology	4-71
4.9.3 Identification, Description and Social Environmental Assessment	4-72

4.9.4 Socio-Environmental Management Plans.....	4-74
4.9.5 Monitoring and Control Plan	4-76
4.9.6 Cost for the Environmental Impact Management.....	4-79
4.9.7 Conclusions and Recommendations	4-79
4.10 Institutions and Administration	4-80
4.11 Execution Plan	4-86
4.12 Financial Plan	4-89
4.13 Logical Framework of the Eventually Selected Option.....	4-90
4.14 Baseline for Impact Assessment	4-92
4.15 Middle and Long Term Plan	4-92
4.15.1 Flood Control General Plan	4-93
4.15.2 Reforestation and Recovery of Vegetation Plan	4-108
4.15.3 Sediment Control Plan	4-116
5. CONCLUSION AND RECOMMENDATION	5-1
5.1 Conclusion	5-1
5.2 Recommendation	5-1
5.2.1 Recommendation on Implementation of This Project	5-1
5.2.2 Recommendation for Future Flood Control Plan in Peru	5-5

1. EXECUTIVE SUMMARY

1.1 Project Name

“Protection program for valleys and rural communities vulnerable to floods Implementation of prevention measures to control overflows and floods of Chincha River, Ica department.”

1.2 Project’s Objective

The ultimate impact that the project is design to achieve is to alleviate the vulnerability of valleys and the local community to flooding and boost local socioeconomic development.

1.3 Supply and Demand Balance

It has been calculated the theoretical water level in case of flow design flood based on the cross sectional survey of the river with an interval of 500m, in the Chincha river watershed, assuming a design flood flow equal to the flood flow with a return period of 50 years. Then, we determined the dike height as the sum of the design water level plus the dike’s free board.

This is the required height of the dike to control the damages caused by design floods and is the indicator of the demand of the local community.

The height of the existing dike or current ground height is the required height to control the current flood damages, and is the indicator of the current offer.

The difference between the dike design height (demand) and the height of the embankment or ground at present ground (supply) is the difference or gap between demand and supply.

Table 1.3-1 shows the average water levels floods, calculated with a return period of 50 years, of the required height of the dike (demand) to control the flow by adding the design water level plus the free board of the dike; of dike height or current ground height (supply), and the difference between these two (difference between demand and supply) of the river. Then, in Table 4.2-2 the values at each point are shown. The current height of the dike or the current ground height is greater than the required height of the dike, at certain points. In these, the difference between supply and demand is considered null.

Table 1.3-1 Demand and supply analysis

Watershed	Dike Height / current land (supply)		Theoretical water level with a return period of 50 years	Dike Freeboard	Required dike's height (demand)	Diff. demand/supply	
	Left bank	Right bank				Left bank	Right bank
	①	②				③	④
Chincha							
Chico	144.81	145.29	144.00	0.80	114.8	0.4	0.45
Matagente	133.72	133.12	132.21	0.80	133.01	0.29	0.36

1.4 Technical Proposal

1.4 .1 Structural Measures

Structural measures are a subject that must be analyzed in the flood control plan covering the entire watershed. The analysis results are presented in section 1.14 “medium and long term plan” This plan proposes the construction of dikes for flood control throughout the watershed. However, the case of Chincha River requires a large project investing at a extremely high cost, far beyond the budget for this Project, which makes this proposal it impractical. Therefore, assuming that the dikes to control floods throughout the whole basin will be constructed progressively over a medium and long term period. Here is where this study focused on the most urgent works, priority for flood control.

(1) Design flood flow

The Methodological Guide for Protection Projects and/or Flood Control in Agricultural or Urban Areas (Guia Metodologica para Proyectos de Proteccion y/o Control de Inundaciones en Áreas Agrícolas o Urbanas, 3.1.1 Horizonte de Proyectos) prepared by the Public Sector Multi Annual Programming General Direction (DGPM) (present DGPI) of the Ministry of Economy and Finance (MEF) recommends a comparative analysis of different return periods: 25, 50 and 100 years for the urban area and 10, 25 and 50 years for rural and agricultural land.

Considering that the present Project is aimed at protecting the rural and agricultural land, the design flood flow is to be determined in a return period of 10 years to 50 years t in the mentioned Guide.

The maximum discharge in the past in Chincha basin occurred before 1960s, and the maximum discharges in recent 40 years are less than the discharge with return period of 50-year so that the flood discharge with return period of 50 years in the Chincha basin is determined as design flood discharge..

In Peru the flood protection works in the basins are developed almost nil, therefore it is not necessary to adopt the design discharge more than the past maximum discharge. However, the large disasters occurred in the past so that the design flood discharge with return period of 50 years, which is almost equal to the past maximum, is to be adopted considering to avoid the flood damage nearly equal to the damage occurred in the past .

The relation among flood discharge with different return period, damage caused by the floods and inundation areas is analyzed in the basin. The results are that the more the return periods of flood increase the more inundation area and damage amount increase in the basin, however the increase tendency of damage with project is more gentle compared with former two items, and the reduction of damage with project reaches to maximum in the case of the flood with return period of 50 years within the cases of flood with less return period of 50 years.

As described above, the adopted design flood discharge with return period of 50 years is almost same as the past maximum discharge and damage reduction amount in the adopted case becomes more than that of the flood discharges with less return period, and the result of social evaluation is also high.

(2) Selection of prioritized flood prevention works

We applied the following five criteria for the selection of priority flood control works.

- Demand from the local community (based on historical flood damage)
- Lack of discharge capacity of river channel (including the sections affected by the scouring)
- Conditions of the adjacent area (conditions in urban areas, farmland, etc.).
- Conditions and area of inundation (type and extent of inundation according to inundation analysis)
- Social and environmental conditions (important local infrastructures)

Based on the river survey, field investigation, discharge capacity analysis of river channel, inundation analysis, and interviews to the local community (irrigation committee needs, local governments, historical flood damage, etc...) a comprehensive evaluation was made applying the five evaluation criteria listed above. After that we selected a total of five (5) critical points (with the highest score in the assessment) that require flood protection measures.

Concretely, since the river cross sectional survey was carried out every 500m interval and discharge capacity analysis and inundation analysis were performed based on the survey results, the integral assessment was also done for sections of 500 meters. This sections have been assessed in scales of 1 to 3 (0 point, 1 point and 2 points) and the sections of which score is more than 6 were selected as prioritized areas. The lowest limit (6 points) has been determined also taking into account the budget available for the Project in general

1.4.2 Non-Structural Measures

(1) Reforestation and vegetation recovery

1) Basic policies

The reforestation plan and vegetation recovery that meets the objective of this project can be divided into: i) reforestation along river structures, and ii) reforestation in the upper watershed. The first has a direct effect on flood prevention expressing its impact in a short time, while the second one requires high cost and a long period for its implementation, as indicated later in the section 1.14 “Reforestation Plan and vegetation recovery”, and also it is impractical to be implemented within the framework of this project. Therefore, this study focused on the first alternative.

(2) Regarding reforestation along river structures

This alternative proposes planting trees along the river structures, including dikes and bank protection works.

- Objective: Reduce the impact of flooding of the river when an unexpected flood or narrowing of the river by the presence of obstacles, using vegetation strips between the river and the elements to be protected.

- Methodology: Create vegetation stripes of a certain width between the river and river structures.
- Execution of works: Plant vegetation on a portion of the river structures (dikes, etc.).
- Maintenance after reforestation: Maintenance will be taken by irrigation committees under their own initiative.

The width, length and area of reforestation along river structures are 11m, 4.6 km and 10.1ha respectively.

(2) Sediment control plan

The sediment control plan must be analyzed within the general plan of the watershed. The results of the analysis are presented in section 1.14 “Medium and long term plan”. To sum up, the sediment control plan for the entire watershed requires a high investment cost, which goes far beyond the budget of this project, which makes it impractical to adopt.

There are different types of sediment control applicable on alluvial fans, for example, sediment retardant reservoir, bed compact, bands, breakwater and ravines protection works, combining some of them. These works do not only are useful to control sediments, but also for fluvial structures. In case of Chincha Watershed, a diversion weir want to be built (Chico-3) in the section where the river divides into two (Chico and Matagente). This flood control work is rated as priority and it includes a channels and a longitudinal dike. Apart from controlling floods, it also controls sediments. This structure is characterized to be economic and it has a high investment return, compared to other sediment control works that are covering the whole watershed. It is considered that its investment return is much higher, even though the maintenance cost is taken into account (stones elimination, etc).

1.4.3 Technical Support

Based on the technical proposals of structural and nonstructural measures, it is also intends to incorporate in this project technical assistance to strengthen the measures.

The objective of the technical assistance is to “improve the capacity and technical level of the local community, to manage risk to reduce flood damage in selected valleys.”

It is proposed to design the adequate support for Chincha river watershed, to offer training adapted to the characteristics of this watershed. The beneficiaries are the representatives of the committees and irrigation groups from the watershed of the Chincha river, governments employees (provincial and district), local community representatives, local people etc...

Qualified as participants in the training, people with ability to replicate and disseminate lessons learned in the courses to other community members, through meetings of the organizations to which they belong.

In order to carry out the technical assistance goal, the three activities propose the following:

- Bank protection activity and knowledge enhancement on agriculture and natural environment

- Community disaster prevention planning for flood damages
- Watershed (slope) management against fluvial sedimentation

1.5 Costs

In the Table 1.5-1 the costs of this Project in Chincha watershed is shown. The cost of the watersheds is around 48.8 million soles.

Table 1.5-1 Project cost

					(1000 soles)
Watershed	Construction Cost	Consultant Cost	Land Acquisition Cost	Management Cost of Implementation Agency	Total Cost
Chincha	41,379	5,022	623	1,734	48,759

1.6 Social Assessment

The objective of the social assessment in this study is to evaluate the efficiency of investments in the structural measures from the point of view of national economy. To do this, we determined the economic evaluation indicators (B/C relation, Net Present Value-NPV, and Internal return rate - IRR).

The benefits of the evaluation period were estimated, from the first 15 years since the start of the project. Because, from these 15 years, two are from the work execution period, the evaluation was conducted for the 13 years following the completion of works. Below the social assessment results for this Project based on the above economic evaluation indicators are shown.

Table 1.6-1 Social evaluation

	流域 Basin	年平均被害軽減額	評価期間被害軽減額(15年)	事業費	維持管理費	B/C	Net Present Value (NPV)	Internal Rate of Return (IRR)
		Average Annual Damage Reduction Amount	Damage Reduction Amount in Evaluation Period(15years)	Project Cost	Operation & Maintenance Cost	Benefit and Cost Ratio	Valor Actual Neto (VAN)	Tasa Interna de Retorno (TIR)
Private Price	Chincha	266,913,530	120,532,859	47,024,405	5,653,615	2.76	76,905,695	35%
Social Price	Chincha	313,198,474	141,434,223	39,164,079	4,822,421	3.89	105,033,115	47%

Regarding social prices costs, the project may show a positive economic impact in Chincha, the relation B/C will be over 1.0.

Next, the positive effects of the Project are shown, which are quite difficult to quantify in economic values:

- ① Contribution to local economic development to alleviate the fear to economic activities suspension and damages
- ② Contribution to increase local employment opportunities thanks to the local construction project

- ③ Strengthening the awareness of local people regarding damages from floods and other disasters
- ④ Contribution to increase from stable agricultural production income, relieving flood damage
- ⑤ Rise in farmland prices

From the results of the economic evaluation presented above, it is considered that this project will substantially contribute to the development of the local economy.

1.7 Sustainability Analysis

This project will be co-managed by the central government (through the DGIH), irrigation committees and regional governments, and the project cost will be covered with the respective contributions of the three parties. On the other hand, the operation and maintenance (O & M) of completed works is taken by the irrigation committees. Therefore, the sustainability of the project is depends on the profitability of the project and the ability of O & M of irrigation committees.

The profitability of the project is high enough as described in the clause 1.6 so that the sustainability of the project is guaranteed.

In the Table 1.7-1 the budget data from last year of the irrigation commissions is shown.

Table 1.7-1 Irrigation Commission's budget

Rivers	Annual Budget			(Unit/ S)
	2007	2008	2009	2010
Chincha	1,562,928.56	1,763,741.29	1,483,108.19	-

On the other hand the annual O/M cost required after implementation of the Project is as shown in the Table-1.7-2, of which detail is described in the clause 4.4.1. The percentage of O/M cost to the annual budget of irrigation committee in the basin and the annual flood damage reduction amount is also as shown in the same table.

The percentage of O/M cost to the annual budget of irrigation committee is 29.3% . And the percentage of O/M cost to the annual flood damage reduction amount is 2.1%, which is very low. Although the percentage of O/M cost to the annual budget is relatively high, the percentage of O/M cost to the yearly average damage reduction amount is very low. Since the benefit of agriculture increases due to the reduction of flood damage, it is possible enough that the irrigation committees will bear the O/M cost. The technical capacity of irrigation committee for O/M seems to be enough by the technical assistance of MINAG and regional government because the flood prevention facilities such as embankment, bank protection and weir are familiar structures to the committee

Table 1.7-2 Percentage of O/M cost to annual budget and damage reduction amount

Irrigation Committee	Annual Budget(1,000 soles)	O/M Cost(1,000 soles)	Percentage of O/M cost(%)	Average Yearly Damage Reduction(1,000soles)	Percentage of O/M cost(%)
	①	②	③=②/①	④	⑤=②/④
Chincha	1,483	435	29.3	20,532	2.1

1.8 Environmental Impact

(1) Procedure of environmental impact assessment

Projects are categorized in three scales, based on the significance level of the negative and positive impacts, and each sector has an independent competence on this categorization. The Project holder should submit the Environmental Impact Statement (DIA, in Spanish) for all Projects under Category I. The project holder should prepare an EIA-sd or an EIA-d if the Project is categorized under Category II or III, respectively, to be granted the Environmental Certification from the relevant Ministry Directorate.

First, the Project holder applies for the Project classification, by submitting the Preliminary Environmental Assessment (PEA). The relevant sector assesses and categorizes the Project. The Project's PEA that is categorized under Category I becomes an EID, and those Projects categorized under Category II or III should prepare an EIA-sd or EIA-d, as applicable.

The preliminary environmental assessment (EAP) for Chincha was carried out between December 2010 and January 2011 and by a consulting firm registered in the Ministry of Agriculture (CIDES Ingenieros S.A.). EAP for chincha was submitted to DGIH January 25, 2011 by JICA Study Team and from DGIH to DGAA July 19, 2011.

DGAA examined EAP and issued approval letter of Category I. Therefore, no further environmental impact assessment is required for Chincha.

(2) Results of Environmental Impact Assessment

The procedures to review and evaluate the impact of the natural and social environment of the Project are the following. First, we reviewed the implementation schedule of the construction of river structures, and proceeded to develop the Leopold matrix.

The impact at environmental level (natural, biological and social environment) was evaluated and at Project level (construction and maintenance stage). The quantitative levels were determined by quantifying the environmental impact in terms of impact to nature, manifestation possibility, magnitude (intensity, reach, duration and reversibility).

The EAP showed that the environmental impact would be manifested by the implementation of this project in the construction and maintenance stages, mostly, it is not very noticeable, and if it were, it

can be prevented or mitigated by appropriately implementing the management plan environmental impact.

On the other hand, the positive impact is very noticeable in the maintenance stage, which manifests at socioeconomic and environmental level, specifically, in greater security and reduced vulnerability, improved life quality and land use.

1.9 Institutions and Management

The institutions and its administration in the investment stage and in the operation and maintenance stage after the investment are as shown in the Figures 1.9-1 and 1.9-2.

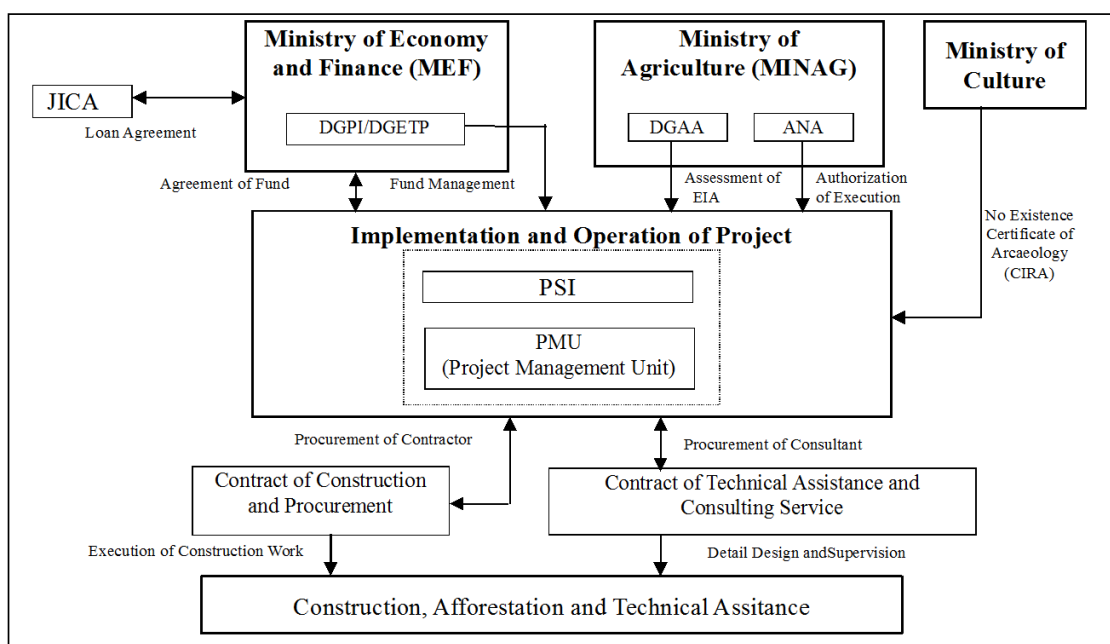

Figure 1.9-1 Related agencies in implementation stage of project

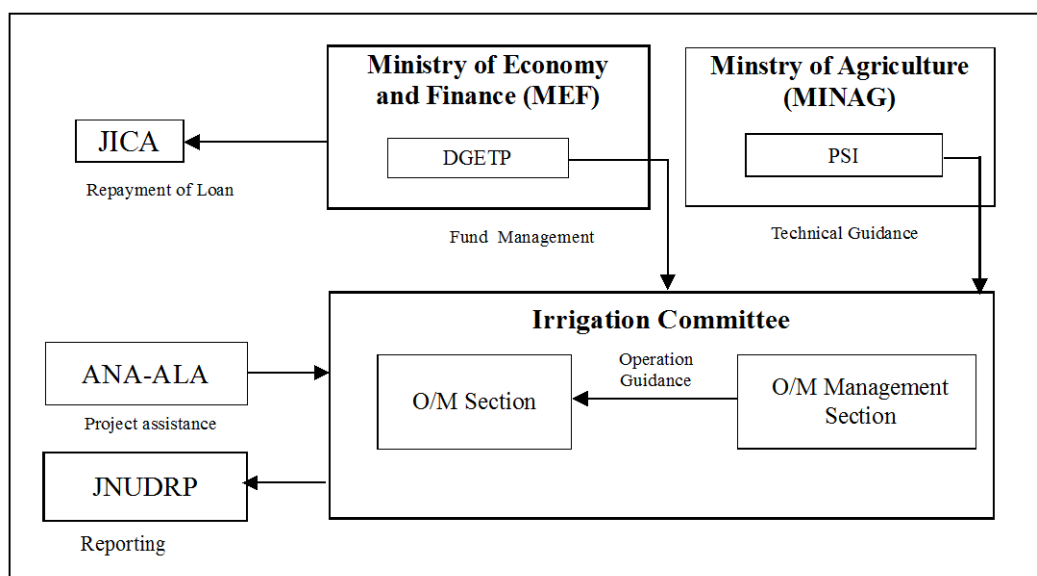
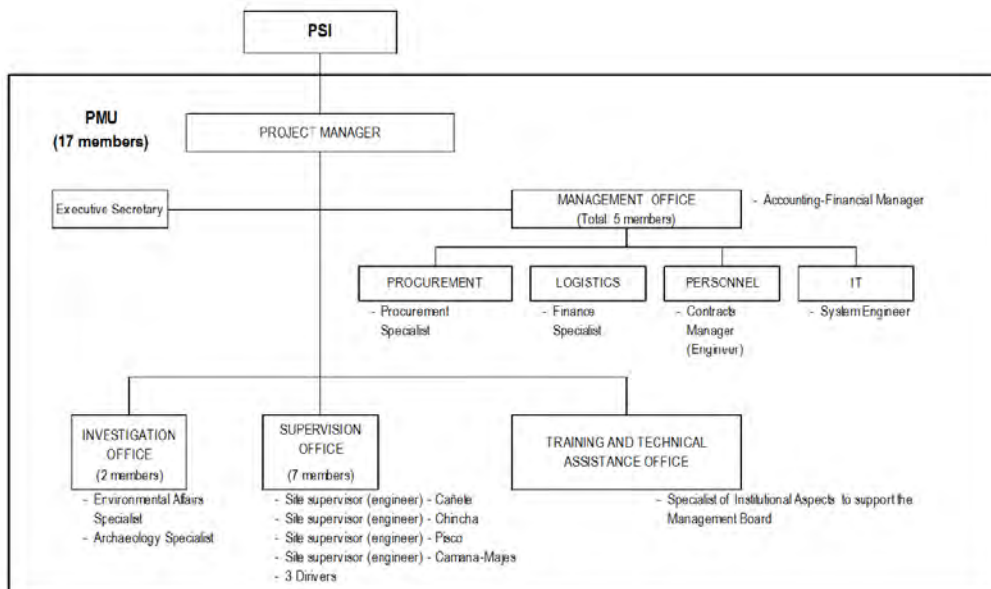

Figure 1.9-2 Related agencies in operation stage of project

The Project Management Unit (PMU) is to be organized under the Irrigation Infrastructure Direction of PSI, of which organization is as shown in the Figure-1.9-3 and 13 professionals are arranged. The operation cost of PMU is estimated as million soles.



Note: () shows number of personnel

Figure-1.9-3 Organization of PMU

1.10 Execution Plan

Table 1.10-1 presents the Project execution plan.

Table 1.10-1 Execution plan

Item	2010	2011	2012	2013	2014	2015	2016	2017	2018	Months
	3 6 9 12	3 6 9 12	3 6 9 12	3 6 9 12	3 6 9 12	3 6 9 12	3 6 9 12	3 6 9 12	3 6 9 12	
1 Profile Study/SNIP Appraisal	Study			Appraisal						28
2 Feasibility Study/SNIP Appraisal		Study		Appraisal						27
3 Loan Appraisal										6
4 Selection of Consultant										10
5 Project Management Unit										45
6 Consulting Services										45
1) Detailed Design										6
2) Tender Preparation, Assistance										15
3) Supervision										24
7 Selection of Contractor, Contract										15
8 Implementation										
1) Structural Measures										24
2) Vegetation										24
3) Disaster Education/Capacity Building										24
4) Land Acquisition										27
9 Completion/Inauguration										-

1) Employment of consultants

The employment of consultant is to be made according the following itmes:

- ① The consultants should be active in international market and have enough qualification and experience.

- ② The consultants are to have efficiency, transparency and non-discrimination among eligible consultants
- ③ The selection procedure should be taken in accordance with the stipulation in the Loan Agreement and the guideline for the Employment of Consultants under Japanese ODA Loans prepared by JICA

2) Procurement of contractor

The procurement of contractors is to be made according to the following items:

- ① The procurement of contractors is to be made using due attention to considerations of economy, efficiency, transparency and non-discrimination among eligible bidders.
- ② The procurement procedure should be taken in accordance with the stipulation in the Loan Agreement and the guideline for the Employment of Consultants under Japanese ODA Loans prepared by JICA
- ③ The International Competitive Bidding: ICB is to be applied.
- ④ The pre-qualification (PQ) of bidders is to be applied in order to confirm the technical and financial capability of bidders. The following items are to be considered in PQ: a) experience of and past performance on similar contracts, b) capabilities with respect to personnel, equipment and plant, c) financial position.

1.11 Financial Planning

This Project will be implemented by the central government, local government and irrigation committee. The cost sharing ratio among central government, local governments and irrigation committees is provisionally assumed to be 80%, 15% and 5% respectively. The final cost sharing ratio among stakeholders shall be determined through the discussions among them as soon as possible.

Table 1.11-1 Financial planning in implementation of project

(thousand soles)

	Item		Amount	Remarks
1	Project cost	①	239,474	
2	Yen loan	②	64,750	25millionUS\$x2.59
	Counter fund	③	174,724	①-②
3	Central government	④	139,779	③x80%
4	regional government	⑤	26,209	③x15%
	(1) Lima (canete)	⑥	3,355	⑤x12.8%(Ratio of Project Cost)
	(2) Ica (Chincha)	⑦	5,347	⑤x20.4%(Ratio of Project Cost)
	(Pisco)	⑧	7,548	⑤x28.8%(Ratio of Project Cost)
	Subtotal	⑨	12,895	⑦+⑧
	(3) Arequipa (Majes-Camana)	⑩	9,959	⑤x38.0%(Ratio of Project Cost)
5	Irrigation committee	⑪	8,736	③x5%
	(1) Canate	⑫	1,118	⑪x12.8%(Ratio of Project Cost)
	(2) Chincha	⑬	1,782	⑪x20.4%(Ratio of Project Cost)
	(3) Pisco	⑭	2,516	⑪x28.8%(Ratio of Project Cost)
	(4) Majes-Camana	⑮	3,320	⑪x38.0%(Ratio of Project Cost)

Note) 1 US \$ = 83.6 yen = 2.59 soles, 1 sol = 32.3 yen

1.12 Conclusion and Recommendation

1.12.1 Conclusion

The flood prevention facilities selected finally in this Project are safe in structural, and have high viability and give scarcely impact to the environment. It is concluded that the Project should be implemented as soon as possible so that the high vulnerability against flood in valleys (Valles) and rural communities could be reduced and the social economic development will be promoted in the Project area.

1.12.2 Recommendation

Based on the knowledge and experience obtained from this Study, the following recommendations are presented on the implementation of this Project and the future flood control measures in Peru. For further detail refer to the main text 5.2.2.

(1) Recommendation on implementation of this project

1) Problems to be solved at present

- * Sharing ratio of Project cost among the central government(MINAG), the local governments and Irrigation committees in each basin
- * Negotiation of land acquisition and compensation with local people
- * Confirmation of implementation agency of the Project
- * Acquisition of CIRA (Certificación de Inexistente de Restos Arqueológicos)
- * Technical and economic assistance for the maintenance performed by irrigation committees by MINAG and local government

2) Structural measures

- * Basic policy of flood control
- * Problems for flood control planning in Chincha
- * Problems in design and construction work
 - Construction work period is to be 9 months from April to December considering transition period to dry season from May to November
 - Stability of embankment
 - Requirement of stability analysis and infiltration analysis in the detail design stage
 - Method of compaction of embankment and supervision
 - Reduction of bank protection cost which occupies 80% of construction cost
 - Balance of embankment volume and excavation volume
 - Hydraulic model experiment in diversion weir in Chincha river

3) Non-structural measures

- * Necessity of reforestation such as i) Short term plan, ii) Medium term plan(upstream area of Chincha river) and iii) Long term plan
- * Sediment control and riverbed fluctuation

- Sediment control facility plan and soft counter measures
 - Riverbed fluctuation and necessity of monitoring
- 4) Disaster prevention education/capacity development
- * Soft counter measures for reduction of flood damage
 - * Promotion of community disaster prevention

(2) Recommendation for Future Flood Control Plan in Peru

- 1) Preparation of comprehensive mater pan for flood control
- 2) Establishment of implementation agency for integral flood control project
- 3) Execution of strict river management
- 4) Establishment of nationwide network of rainfall observation stations and discharge observation stations

1.13 Logical Framework

Table 1.13-1 presents the logical framework of the final selected alternative.

Table 1.13-1 Logical framework of the final selected alternative

Narrative Summary	Verifying Indicators	Verifying Indicators Media	Preliminary Conditions
Superior Goal			
Promote socioeconomic local development and contribute in communities' social welfare.	Improve local productivity, generate more jobs, increase population's income and reduce poverty index	Published statistic data	Socio-economic and policy stability
Objectives			
Relief the high vulnerability of valleys and local continuity to floods	Types, quantity and distribution of flood control works, population and beneficiaries areas	Monitoring annual calendar works and financial plan, budget execution control	Ensure the necessary budget, active intervention from central and regional governments, municipalities, irrigation communities, local population, etc.
Expected results			
Reduction of number and flooded areas, functional improvement of intakes, irrigation channels protection, bank erosion control	Number of areas and flooded areas, water intake flow variation, bank erosion progress	Site visits, review of the flood control plan and flood control works reports and periodic monitoring of local inhabitants	Maintenance monitoring by regional governments, municipalities and local community, provide timely information to the superior organisms
Activities			
Component A: Structural Measures	Dikes rehabilitation, intake and margin protection works construction of 23 works, including dike's safety	Detailed design review, works reports, executed expenses	Ensure the works budget, detailed design/works execution/good quality works supervision
Component B: Non-Structural Measures (Reforestation and vegetation recovery)	Reforested area, coastal forest area	Works advance reports, periodic monitor by local community	Consultants support, NGO's, local community, gathering and cooperation of lower watershed

			community
Component C: Disaster prevention and capabilities development education	Number of seminars, trainings, workshops, etc	Progress reports, local governments and community monitoring	Predisposition of the parties to participate, consultants and NGO's assessments
Project's execution management			
Project's management	Detailed design, work start order, work operation and maintenance supervision	Design plans, work's execution plans, costs estimation, works specifications, works management reports and maintenance manuals	High level consultants and contractors selection, beneficiaries population participation in operation and maintenance

1.14 Middle and Long Term Plans

While it is true that due to the limited budget available for the Project, this study is focused mainly on the flood control measures analysis that must be implemented urgently. It is considered necessary to timely implement other necessary measures within a long term. In this section we will discuss the medium and long term plans.

(1) Flood control general plan

There are several ways to control floods in the entire watershed, for example, the building of dams, retarding basin, dikes or a combination of these. The options to build dams or retarding basin are not viable because in order to answer to a flood flow with a return period of 50 years, enormous works would be necessary to be built. So, the study was focused here on dikes' construction because it was the most viable option.

Flood water level was calculated in the watershed adopting a designed flood flow with a return period of 50 years. At this water level, freeboard was added in order to determine the required dikes height. After, sections of the rivers where the dikes or ground did not reach the required height were identified. These sections, altogether, add up to approx.. 26km. Also, from maintaining these works, annually a dragged of the rivers has to be done in the sections where, according to the bed fluctuation analysis the sediment gathering is elevating the bed's height. The volume of sediments that shall be eliminated annually was determined in approximately 10,000 m³.

In Tables 1.14-1 and 1.14-2 the flood control general plan project cost is shown as well as the social assessment results in terms of private and social costs.

**Table 1.14-1 Project cost and social assessment of the general flood control plan
(private prices costs)**

流域名	年平均被害軽減額	評価期間被害軽減額(15年)	事業費	維持管理費	B/C	NPV	IRR(%)
Basin	Annual Average Damage Reduction	Damage Reduction in Evaluation Period(15years)	Project Cost	O&M Cost	Cost Benefit Ration	Net Present Value	Internal Return of Rate
Chincha	292,863,416	132,251,314	84,324,667	7,429,667	1.71	55,091,224	21%

**Table 1.14-2 Project cost and social assessment of the general flood control plan
(social prices costs)**

流域名	年平均被害軽減額	評価期間被害軽減額(15年)	事業費	維持管理費	B/C	NPV	IRR(%)
Basin	Annual Average Damage Reduction	Damage Reduction in Evaluation Period(15years)	Project Cost	O&M Cost	Cost Benefit Ration	Net Present Value	Internal Return of Rate
Chincha	349,827,412	157,975,125	67,797,033	5,973,452	2.55	95,938,413	32%

In case of executing flood control works in the watershed, the Projects' cost would elevate to 84.3 million soles, which is a huge amount.

(2) Reforestation plan and vegetation recovery

The forestry option was analyzed, in a long term basis, to cover every area that requires being covered with vegetation in the upper watershed. The objective is improving this areas' infiltration capacity, reduce of surface water and increase semi-underground and underground water. So, the flood maximum flow will be decreased, also it could be possible to increase the water reserve in the mountain areas and prevent and soothe floods. The areas to be reforested will be the afforested areas or where the forest mass in the water infiltration areas has been lost.

In Table 1.14-3 the area to be afforested and the project's cost for the watershed is shown. These were calculated based on forestry plan of Chincha River (refer to Annex-7 Afforestation and Vegetation Recovery Plan, 3.2 Long Term Plan). The total surface would be approximately 44,000hectares and in order to forest them the required time would be from 14 years and 119.0 million soles. To sum up, the Project has to cover an extensive area, with an investment of much time and at a high price.

Table 1.14-3 General plan for forestry on upper stream watersheds

Watershed	Forestry Area (ha) A	Required Period for the project (years) B	Required Budget (1,000soles) C
Chincha	44,075	14	118,964

(3) Sediment control plan

As long term sediment control plan, it is recommended to perform necessary works on the upper watershed. These works will mainly consist of dams and bank protection. In Table 1.14-4 the estimate work cost is shown. There are two costs, one for executing works in the entire watershed and another one for executing works only in prioritized areas based on the slope of river channel (refer to Annex-6, Sediment Control , Table-1.5.1).

All the chosen watersheds for this Project are big. So, if bank protection works and sediment control dams want to be built, not only the works' cost would elevate but also a very long period of investment would have to be done in the watershed. This means that its positive impact will be seen in a long time.

**Table 1.14-4 Projects' general costs of the sediment
control installations upstream the watershed**

Watershed	Areas	Bank Protection		Bands		Dams		Works direct cost (total)	Project Cost (in millions de s/.)
		Qty. (km)	Works direct costs (million s/.)	Qty. (No.)	Works direct costs (million s/.)	Qty. (No.)	Works direct costs (million s/.)		
Chincha	Totally	381	S/.407	38	S/.1	111	S/.116	S/.524	S/..986
	Prioritized areas	381	S/.407	38	S/.1	66	S/.66	S/.474	S/.892

2. GENERAL ASPECTS

2.1 Name of the Project

“Protection program for valleys and rural communities vulnerable to floods Implementation of prevention measures to control overflows and floods of Chincha River, Ica department”

2.2 Formulator and Executor Units

(1) Formulator Unit (UF)

Name: Hydraulic Infrastructure General Direction, Agriculture Ministry
Responsible: Gustavo Adolfo Canales Kriljenko
General Director of the Water Infrastructure General Direction
Address: Av. Guillermo Prescott No. 490, San Isidro – Perú
Phone: (511) 6148100, (511) 6148101
Email: gcanales@minag.gob.pe

(2) Executor Unit (UE)

Name: Sub-sectorial Irrigation Program, Agriculture Ministry
Manager: Jorge Zúñiga Morgan
Executive Director
Address: Jr. Emilio Fernandez N° 130 Santa Beatriz, Lima-Peru
Phone: (511) 4244488
Email: postmast@psi.gob.pe

2.3 Involved Entities and Beneficiaries Participation

Here are the institutions and entities involved in this project, as well as beneficiaries.

(1) Agriculture Ministry (MINAG)

MINAG, as manager of natural resources of watersheds promotes agricultural development in each of them and is responsible of maintaining the economical, social and environmental to benefit agricultural development.

To accomplish effectively and efficiently this objective, the MINAG has been working since 1999 in the River Channeling and Collection Structures Protection Program (PERPEC). The river disaster prevention programs that are been carried out by regional governments are funded with PERPEC resources.

1) General Administration Office (OGA)

- Manages and executes the program’s budget
- Establishes the preparation of management guides and financial affairs

2) Hydraulic Infrastructure general Direction (DGIH)

- Performs the study, control and implementation of the investment program

- Develops general guidelines of the program together with OPI
- 3) Planning and Investment Office (OPI), present Planning and Budgetary Office (OPP)
- Conducts the preliminary assessment of the investment program
 - Assumes the program's management and the execution of the program's budget
 - Plans the preparation of management guides and financial affairs
- 4) Irrigation Sub-Sectorial Program (PSI)
- Carries-out the investment program approved by OPI and DGPM

(2) Economy and Finance Ministry (MEF)

Investment Policy General Direction (DGPI; previous DGPM) is in charge of approving public investment works according to procedures under the Public Investment National System (SNIP) to assess the relevance and feasibility of processing the disbursement request of the national budget and the loan from JICA.

(3) Japan's International Cooperation Agency (JICA)

It is a Japanese government institution with the objective of contributing in the socioeconomic development of developing countries through international cooperation. JICA has extended financial assistance to carry out profile and feasibility studies of this Project.

(4) Regional Governments (GORE)

Regional governments assume the promotion of integrated and sustainable regional development following the national and regional plans and programs, trying to increase public and private investment, generating employment opportunities, protecting citizens rights and ensuring equal opportunities.

The regional governments' participation with their possible financial support is a very important factor to ensure the Project's sustainability.

(5) Irrigation Commission

Currently there are 14 irrigation commissions in the Chincha River Watershed. These have expressed a strong desire for the starting of works because these will help constructing dikes, protecting margins, repairing water intakes, etc. These commissions are currently suffering major damages due to rivers flooding. Next, a brief overview of the Chincha River Watershed is described (for more details, see Section 3.1.3). Currently, the operation and maintenance of dikes, margin protection works, irrigation intakes and channels linked to agricultural land and irrigation systems in the Watershed, are mainly made by irrigation commissions and their members, with the assistance of local governments.

Number of irrigation blocks:	3
Number of Irrigation	14
Commissions:	
Irrigated Area:	25,629 ha
Beneficiaries:	7.676 producers

(6) Meteorology and Hydrology National Service (SENAMHI)

It is an agency from the Environment Ministry responsible for all activities related to meteorology, hydrology, environment and agricultural meteorology. Take part in global level monitoring, contributing to sustainable development, security and national welfare, and gathering information and data from meteorological stations and hydrological observation.

(7) Civil Defense National Institute (INDECI)

INDECI is the main agency and coordinator of SINAGERD (Sistema Nacional de Gestioh del Riesgo de Desastiv, established in May 2011. It is responsible for organizing and coordinating the community, elaborating plans and developing disaster risk's management processes. Its objective is to prevent or alleviate human life loss due to natural and human disasters and prevent destruction of property and the environment.

(8) Water National Authority (ANA)

It is the highest technical regulating authority in charge of promoting, monitoring and controlling politics, plans, programs and regulations regarding sustainable use of water resources nationwide.

Its functions include sustainable management of these resources, as well as improving the technical and legal framework on monitoring and assessment of water supply operations in each region.

Along with maintaining and promoting a sustainable use of water resources, it is also responsible for conducting the necessary studies and developing main maintenance plans, national and international economic and technical cooperation programs.

(9) Agriculture Regional Directorates (DRA's)

Agricultural regional addresses fulfill the following functions under the respective regional government:

- 1) Develop, approve, assess, implement, control and manage national agriculture policies, sectorial plans as well as regional plans and policies proposed by municipalities
- 2) Control agriculture activities and services fitting them to related policies and regulations, as well as on the regional potential
- 3) Participate in the sustainable management of water resources agreeing with the watershed's general framework, as well as the policies of the Water National Authority (ANA)
- 4) Promote the restructure of areas, market development, export and agricultural and agro-industrial products consumption
- 5) Promote the management of: irrigation, construction and irrigation repair programs, as well as the proper management and water resources and soil conservation

2.4 Framework

2.4.1 Background

(1) Background

The Republic of Peru (hereinafter “Peru”) is a country with high risk of natural disasters such as earthquakes, Tsunamis, etc. Among these natural disasters there are also floods. In particular, El Niño takes place with an interval of several years and has caused major flood of rivers and landslides in different parts of the country. The most serious disaster in recent years due to El Niño occurred in the rainy season of 1982-1983 and 1997-1998. In particular, the period of 1997-1998, the floods, landslides, among others left loss of 3,500 million of dollars nationwide. The latest floods in late January 2010, nearby Machupicchu World Heritage Site, due to heavy rains interrupted railway and roads traffic, leaving almost 2,000 people isolated. In Majes-Camana river the flood with discharge of over 1,100m³/sec (equivalent to about 10years probability flood) occurred at the midnight in February 13, 2012 causing flood disaster in the project area. The total area of inundation was 1,085 ha, the total length of 780m of dike was destroyed , and the main irrigation canal of 800m and secondary canal of 1,550m were damaged. And in Pisco river the dike in various areas was damaged and the Miraflores road bridge in Humay area was washed away.

In this context, the central government has implemented El Niño phenomenon I and II contingency plans in 1997-1998, throughout the Agriculture and Livestock Ministry (MINAG) in order to rebuild water infrastructures devastated by this phenomenon. Next, the Hydraulic Infrastructure General Direction (DGIH) of the Agriculture Ministry (MINAG) began in 1999 the River Channeling and Collection Structures Protection Program (PERPEC) in order to protect villages, farmlands, agricultural infrastructure, etc located within flood risk areas. The program consisted of financial support for regional government to carry out works of margin protection. In the multiyear PERPEC plan between 2007-2009 it had been intended to execute a total of 206 margin protection works nationwide. These projects were designed to withstand floods with a return period of 50 years, but all the works have been small and punctual, without giving a full and integral solution to control floods. So, every time floods occur in different places, damages are still happening.

MINAG developed a “Valley and Rural Populations Vulnerable to Floods Protection Project” for nine watersheds of the five regions. However, due to the limited availability of experiences, technical and financial resources to implement a pre-investment study for a flood control project of such magnitude, MINAG requested JICA’s help to implementation this study. In response to this request, JICA and MINAG held discussions under the premise of implementing it in the preparatory study scheme to formulate a loan draft from AOD of JICA, about the content and scope of the study, the implementation’s schedule, obligations and commitments of both parties, etc. expressing the conclusions in the Discussions Minutes (hereinafter “M/D”) that were signed on January 21 and April 16, 2010. This study was implemented on this M/D.

(2) Progress of Study

The Profile Study Report for this Project at Program's level for nine watersheds of five regions has been elaborated by DGIH and sent to the Planning and Investment Office (OPI) on December 23, 2009, and approved on the 30th of the same month. Afterwards, DGIH presented the report to the Public Sector Multiannual Programming General Direction (DGPM) (present DGPI) of the Economy and Finance Ministry (MEF) on January 18, 2010. On March 19th, DGPM informed DGIH about the results of the review and the correspondent comments.

The JICA Study Team began the study in Peru on September 5th, 2010. At the beginning, nine watersheds were going to be included in the study. One, the Ica River was excluded of the Peruvian proposal leaving eight watersheds. The eight watersheds were divided into two groups: Group A with five watersheds and Group B with three watersheds. The study for the first group was assigned to JICA and the second to DGIH. Group A includes Chira, Cañete, Chincha, Pisco and Yauca Rivers' Watersheds and Group B includes the Cumbaza, Majes and Camana Rivers' Watersheds.

The JICA Study Team conducted the Profile Study of the five watersheds of Group A, with an accurate pre-feasibility level and handed DGIH the Program Report of group A and the reports of the five watershed projects by late June 2011. Also, the feasibility study has already started, omitting the pre-feasibility study.

For the watersheds of Group B which study corresponded to DGIH, this profile study took place between mid-February and early March 2011 (and not with a pre-feasibility level, as established in the Meetings Minutes), where Cumbaza River Watershed was excluded because it was evident that it would not have an economic effect. The report on the Majes and Camana rivers watersheds were delivered to OPI, and OPI official comments were received through DGIH on April 26th, indicating that the performed study for these two watersheds did not meet the accuracy level required and it was necessary to study them again. Also, it was indicated to perform a single study for both rivers because they belong to a single watershed (Majes-Camana).

On the other hand, due to the austerity policy announced on March 31st, prior to the new government assumption by new president on July 28th, it has been noted that it is extremely difficult to obtain new budget, DGIH has requested JICA on May 6th to perform the prefeasibility and feasibility studies of the Majes-Camana Watershed.

JICA accepted this request and decided to perform the mentioned watershed study modifying for the second time the Meeting Minutes (refer to Meetings Minutes Second Amendment about the Initial Report, Lima, July 22nd, 2011)

So, the JICA Study Team began in August the prefeasibility study for the watershed above mentioned, which was completed in late November.

Based on the Profile Study with the pre-feasibility level, the four rivers of Cañete, Chincha, Pisco and Majes-Camana excluding Chira and Yauca rivers are selected for the objective rivers for the feasibility

study under the restriction of total budget for the Project and viability of social evaluation of each river (refer to Minutes of Meetings on Main Points of Interim Report, Lima , December 5, 2011

DGIH registered 4 rivers to SNIP on July 21, 2011 based on the Profile Study reports (for each basin) except Yauca. Yauca river was not registered due to its low viability of the social evaluation judged by DGIH. And DGIH registered Majes-Camana river to SNIP on January 9, 2012. DGIH submitted the Profile Study reports of 4 rivers (Chira, Cañete, Chincha, Pisco excluding Yauca) with pre-FS level accuracy to OPI, which issued their observations on the reports of 4 river to DGIH on September 22, 2011, and on the report of Majes-Camana river on August 4, 2012.

DGIH revised these profile study reports in accordance with the OPI's observation and submitted them to OPI in May 2012 for 3 rivers of Cañete, Chincha, Pisco, and December 12, 2012 for Majes-Camana river.

OPI examined the revised reports of 3 rivers and transferred them to DGPI, MEF together with their comments in July 2012. DGPI, MEF examined the reports and approved the implementation of Feasibility Study for 3 rivers with their comments in October 2012

Since the examination process of OPI and DGPI based on SNIP regulation had delayed, JICA executed the feasibility study on the 4 watersheds which were selected based on the Profile Study and submitted the program report of 4 watersheds and the project reports of each watersheds were submitted to DGIH on March 9, 2012 in draft form.

DGIH has been revising the feasibility study reports in accordance with the comments of MEF, after completion of revision will obtain the approval on the reports from OPI and MEF. And DGIH will take same process for the Majes-Camana river for which the examination and approval process of OPI and MEF delay.

On the other hand, JICA headquarter commented the run-off study on Majes-Camana river in the feasibility study, and JICA Study Team has to begin the review of the study (June 29, 2012). JICA Study Team started the review study in July 2012 and completed the revised run-off study and related various studies in November 2012.

The process of the above is as shown in the Table-2.4.1-1.

Table-2.4.1-1 Process of study and submission of report

Items	Date	Chira	Ica	Chincha	Pisco	Yauca	Cafete	Majes	Camana	Cumbaza	
Perfil Program		December 30, 2009 : prepared and submitted by DGIH, January 18, 2010 : approved by DGPI									
Start of JICA Study	2010/9/5	A group 5 rivers to be studied by JICA					B group 4 rivers to be studied by DGIH				
Amendment of M/M on ICR (No.1)	2010/11/12	-	excluded by DGIH	-	-	-	transferred to A group	-	-	-	
Responsible Organization	-	JICA	-	JICA			DGIH				
Perfil Program Report	2011/3中旬	-	-	-	-	-	-	Preparation and Submission			
DGIH excluded Cumbaza		-	-	-	-	-	-	-	-	excluded by DGIH	
OPI Observation	2011/4/26	-	-	-	-	-	-	Combination of both rivers and upgrade of study directed by OPI		-	
Amendment of M/M on ICR (No2)	2011/6/22	-	-	-	-	-	-	DGIH requested study of this river to JICA		-	
Pre-F/S Level Study	2011/6/30	Submission to DGIH	-	Submission to DGIH				-	-	-	
SNIP Registration	2011/7/21	Registration to SNIP	-	Registration to SNIP		No registration to SNIP	Registration to SNIP	-	-	-	
OPI Observation	2011/9/22	OPI Observation	-	OPI Observation		-	OPI Observation	-	-	-	
Objectives for F/S Study	2011/12/5	excluded	-	Selected		-	Selected	Selected		-	
Pre-F/S Level Study on Majes-Camana	2011/12/15	-	-	-	-	-	-	Submission to DGIH		-	
Pre F/S Program Report of 6 rivers	2011/12/28	Submission to DGIH	-	Submission to DGIH			Submission to DGIH	Submission to DGIH	Submission to DGIH	-	
FS Draft Report	2012/3/9	-	-	Submission to DGIH		-	Submission to DGIH	Submission to DGIH		-	
DGIH revised report to OPI	-	-	-	2012/5/15	2012/5/14	-	2012/5/21	2012/12/12	-	-	
OPI report to MEF	-	-	-	2012/7/26		-	2012/7/26	Unknown	-	-	
MEF approval for FS	-	-	-	2012/10/4	2012/10/16	2012/10/17	-	Unknown	-	-	
DGIH revision of FS report	-	-	-	Under preparation		-	Under preparation	Unknown	-	-	
OPI&MEF approval of revised FS report	-	-	-	Unknown	Unknown	-	Unknown	Unknown	-	-	
Revised Study of Majes-Camana	-	-	-	-	-	-	-	2012/8~2012/11	-	-	
Expalanation of the above	-	-	-	-	-	-	-	Scheduled in 2013/2/27	-	-	
Submission of final FS report	-	-	-	scheduled in 2013/3		-	scheduled in 2013/3	scheduled in 2013/3	-	-	

2.4.2 Laws, Regulations, Policies and Guidelines Related to the Program

This program has been elaborated following the mentioned laws and regulations, policies and guidelines:

(1) Water Resources Law N° 29338

Article 75 .- Protection of water

The National Authority, in view of the Watershed Council, must ensure for the protection of water, including conservation and protection of their sources, ecosystems and natural assets related to it in the regulation framework and other laws applicable. For this purpose, coordination with relevant government institutions and different users must be done.

The National Authority, throughout the proper Watershed Council, executes supervision and control functions in order to prevent and fight the effects of pollution in the oceans, rivers and lakes. It can also coordinate for that purpose with public administration, regional governments and local governments sectors.

The State recognizes as environmentally vulnerable areas the headwater watersheds where the waters originate. The National Authority, with the opinion of the Environment Ministry, may declare protected areas the ones not granted by any right of use, disposition or water dumping.

Article 119 .- Programs flood control and flood disasters

The National Authority, together with respective Watershed Board, promotes integral programs for flood control, natural or manmade disasters and prevention of flood damages or other water impacts and its related assets. This promotes the coordination of structural, institutional and necessary operational measures.

Within the water planning, the development of infrastructure projects for multi-sectorial advantage is promoted. This is considered as flood control, flood protection and other preventive measures.

(2) Water Resources Law Regulation N° 29338

Article 118 .- From the maintenance programs of the marginal strip

The Water Administrative Authority, in coordination with the Agriculture Ministry , regional governments, local governments and water user organizations will promote the development of programs and projects of marginal strips forestry protection from water erosive action.

Article 259 ° .- Obligation to defend margins

All users have as duty to defend river margins against natural phenomenon effects, throughout all areas that can be influenced by an intake, whether it is located on owned land or third parties' land. For this matter, the correspondent projects will be submitted to be reviewed and approved by the Water National Authority.

(3) Water Regulation

Article 49. Preventive measures investments for crop protection are less than the recovery and rehabilitation cost measures. It is important to give higher priority to these protective measures which are more economic and beneficial for the country, and also contribute to public expenses savings.

Article 50. In case the cost of dikes and irrigation channels protection measures is in charge of family production units or it exceeds the payment capacity of users, the Government may pay part of this cost.

(4) Multi-Annual Sectorial Strategic Plan of the Agriculture Ministry for the period 2007-2011 (RM N° 0821-2008-AG)

Promotes the construction and repair of irrigation infrastructure works with the premise of having enough water resources and their proper use.

(5) Organic Law of the Agriculture Ministry, N° 26821

In Article 3, it is stipulated that the agricultural sector is responsible for executing river works and agricultural water management. This means that river works and water management for agricultural purposes shall be paid by the sector.

(6) Guidelines for Peruvian Agricultural Policy - 2002, by the Policy Office of MINAG

Title 10 - Sectorial Policies

“Agriculture is a high risk productive activity due to its vulnerability to climate events, which can be anticipated and mitigated... The damage cost to infrastructure, crops and livestock can be an obstacle for the development of agriculture, and as consequence, in the deterioration of local, regional and national levels.”

(7) River Channeling and Collection Structures Protection Program, PERPEC

The MINAG's DGIH started in 1999 the River Channeling and Collection Structures Protection Program (PERPEC) in order to protect communities, agricultural lands and facilities and other elements of the region from floods damages, extending financial support to margin protection works carried out by regional governments.

3. IDENTIFICATION

3.1 Diagnosis of the Current Situation

3.1.1 Nature

(1) Location

Figure 3.1.1-1 shows the location map of the Chincha River of this study.



Figure 3.1.1-1 Objective river for the study

(2) Watershed overall description

The Chincha River runs 170 km to the south of the Capital of Lima with an approximate surface of 3.300km². It is featured by a middle watershed and narrow lower and high watersheds, its higher altitude is greater than 4.000m.a.s.l and this only represents 15% from the total amount. In the lower watershed (Study Area), the river is split into two by a derivation work located approx 25 km upstream the mouth. The river adopts to the northern part, Chico and Matagente names. The middle slope is approx 1/80 and its width varies between 100 and 200m.

Annual rain is similar to the one in Chincha River Watershed: with 1.000mm at altitudes over 3,000m.a.s.l and only 20mm at altitudes smaller than 500m.a.s.l.

Regarding vegetation, the upper watershed has puna grass and scrublands and the lower watershed in mainly constituted in 80% by desert and 20% of arable lands. This distribution of vegetal formation is like the Pisco River Watershed, which is next to it. The main product in these lands is cotton and grapes.

3.1.2 Socio-Economic Conditions of the Study Area

(1) Administrative division and surface

The Chincha River is located in the provinces of Chincha in the Ica Region. Table 3.1.2-1 shows the main districts surrounding this river, with their corresponding surface.

Table 3.1.2-1 Districts surrounding the Chincha River with areas

Región	Provincia	Distrito	Área (km ²)
Ica	Chincha	Chincha Alta	238.34
		Alto Laren	298.83
		Chincha Baja	72.52
		El Carmen	790.82
		Tambo de Mora	22.00

(2) Population and number of households

The following Table 3.1.2-2 shows how population varied within the period 1993-2007. From the total 94,439 inhabitants (2007), 82% (77,695 inhabitants) lives in urban areas while 18% (16,744 inhabitants) lived in rural areas. However, in Chincha Baja and El Carmen Districts 58% and 57% respectively, live in rural areas, with more rural areas than other areas. Population is increasing in all districts.

Table 3.1.2-2 Variation of the urban and rural population

District	Total Population 2007					Total Population 1993					Variation (%)	
	Urban	%	Rural	%	Total	Urban	%	Rural	%	Total	Urban	Rural
Chincha Alta	59.574	100 %	0	0 %	59.574	49.748	100 %	0	0 %	49.748	1,3 %	0,0 %
Alto Laran	3.686	59 %	2.534	41 %	6.220	1.755	41 %	2.530	59 %	4.285	5,4 %	0,01 %
Chincha Baja	5.113	42 %	7.082	58 %	12.195	3.402	30 %	7.919	70 %	11.321	3,0 %	-0,8 %
El Carmen	5.092	43 %	6.633	57 %	11.725	3.766	43 %	5.031	57 %	8.797	2,2 %	2,0 %
Tambo de Mora	4.230	90 %	495	10 %	4.725	3.176	79 %	868	21 %	4.044	2,1 %	-3,9 %
Total	77.695	82 %	16.744	18 %	94.439	61.847	79 %	16.348	21 %	78.195	1,6 %	0,2 %

Source: Prepared by JICA Study Team, Statistics National Institute- INEI, 2007 and 1993 Population and Housing Census.

Table 3.1.2-3 shows the number of households and members per home. Every home has between 4,0 and 4,4 members and every family among 3,9 and 4,1 members.

Table 3.1.2-3 Number of households and families

Variables	District				
	Chincha Alta	Alto Laran	Chincha Baja	El Carmen	Tambo de Mora
Population (inhabitants)	59,574	6,220	12,195	11,725	4,725
Number of households	13,569	1,522	2,804	2,696	1,124
Number of families	14,841	1,559	2,997	2,893	1,200
Members per house (person/home)	4.39	4.09	4.35	4.35	4.20
Member per family (person/family)	4.01	3.99	4.07	4.05	3.94

(3) Occupation

Table 3.1.2-4, shows occupation lists of local inhabitants itemized by sector. In Chincha Alta and Tambo de Mora where the population is predominantly urban, there is a low percentage of primary sector, meanwhile in the other districts the primary sector is predominant.

Table 3.1.2-5 Occupation

	District									
	Chincha Alta		Alto Laran		Chincha Baja		El Carmen		Tambo de Mora	
	Personas	%	Personas	%	Personas	%	Personas	%	Personas	%
EAP	23,596	100	2,415	100	4,143	100	3,966	100	1,640	100
Primary Sector	1,889	8.0	1,262	52.3	1,908	46.1	2,511	63.3	334	20.4
Secondary Sector	6,514	27.6	443	18.3	931	22.5	399	10.1	573	34.9
Tertiary Sector	15,190	64.4	710	29.4	1,304	31.5	1,056	26.6	733	44.7

* Primary Sector: agriculture, livestock, forestry and fishing; secondary: mining, construction, manufacture; tertiary: services and others

(4) Poverty index

Table 3.1.2-5 shows the poverty index. From the total population, 15,6% (14.721 inhabitants) belong to the poor segment, and 0.3% (312 inhabitants) belong to extreme poverty. Chincha Baja has reached a lower poverty index than the rest, with 10.6% (poor) and 0.2% (extreme poverty).

Table 3.1.2-5 Poverty index

	District											
	Chincha Alta		Alto Laran		Chincha Baja		El Carmen		Tambo de Mora			
	People	%	People	%	People	%	People	%	People	%	Total	%
Regional Population	59,574	100	6,220	100	12,195	100	11,725	100	4,725	100	94,439	100
Poor	9,316	15.6	1,309	21.0	1,296	10.6	1,950	16.6	850	18.0	14,721	15.6
Extreme Poor	214	0.4	30	0.5	22	0.2	35	0.3	11	0.2	312	0.3

(5) Type of housing

The walls of the houses are made 21% of bricks or cement, and 44% of adobe and mud. The floor is made 94% of earth or cement. The public drinking water service is low, with an average of 45%, except for El Carmen and Tambo de Mora, while the sewage service is scarcely 29%. The average electrification rate is 74%.

Table 3.1.2-6 Type of housing

Variable/Indicator	Districts										
	Chincha Alta		Alto Laran		Chincha Baja		El Carmen		Tambo de Mora		
	Housing	%	Housing	%	Housing	%	Housing	%	Housing	%	
Name of housings											
Common residents housing	13.569	85,7	1.522	76,1	2.804	93,3	2.696	87,6	1.124	85,3	
Walls materials											
Bricks or cement	5.220	38,5	170	11,2	590	21	176	6,5	309	27,5	
Adobe and mud	4.817	35,5	891	58,5	1.146	40,9	1.589	58,9	289	25,7	
Bamboo + mud or wood	281	2,1	121	8,0	125	4,5	160	5,9	45	4,0	
Others	3.251	24,0	340	22,3	943	33,6	771	28,6	481	42,8	
Floor Materials											
Soil	5.036	37,1	812	53,4	1.521	54,2	1.547	57,4	604	53,7	
Cement	6.454	47,6	680	44,7	1.136	40,5	1.081	40,1	450	40	
Ceramics, parquet, quality wood	1.979	14,6	25	1,6	134	4,8	42	1,6	58	5,2	
Others	100	0,7	5	0,3	13	0,5	26	1,0	12	1,1	
Running water system											
Public network within household	10.321	76,1	705	46,3	1.055	37,6	861	31,9	379	33,7	
Public network within building	1.030	7,6	87	5,7	239	8,5	242	9	62	5,5	
public use	311	2,3	214	14,1	192	6,8	202	7,5	38	3,4	
Sewage											
Public sewage within household	9.244	68,1	167	11	709	25,3	320	11,9	336	29,9	
Public sewage within building	748	5,5	60	3,9	77	2,7	31	1,1	61	5,4	
Septic Tank	1.441	10,6	621	40,8	1.167	41,6	1.348	50	259	23	
Electricity											
Public electric service	10.989	81	811	53,3	2.251	80,3	2.146	79,6	837	74,5	
Member quantity											
Common residents housing	14.841	100	1.559	100	2.997	100	2.893	100	1.200	100	
Appliances											
More than three	7.024	47,3	466	29,9	1.159	38,7	908	31,4	473	39,4	
Communication Services											
Phones and mobiles	12.640	85,2	920	59,0	2.182	72,8	1.919	66,3	872	72,7	

Source: Prepared by JICA Study Team, Statistics National Institute- INEI, 2007 Population and Housing Census.

(6) GDP

Peru's GDP in 2010 was US\$ 153.919.000.000. The growth rate in the same year was of + 8.8 %

compared with the previous year. Itemized by regions, Ica registered a growth of 8.1 %, Piura 5.4 %, Lima 10.0 % and Arequipa 8.5 %. Particularly Lima regions registered Figures that were beyond the national average.

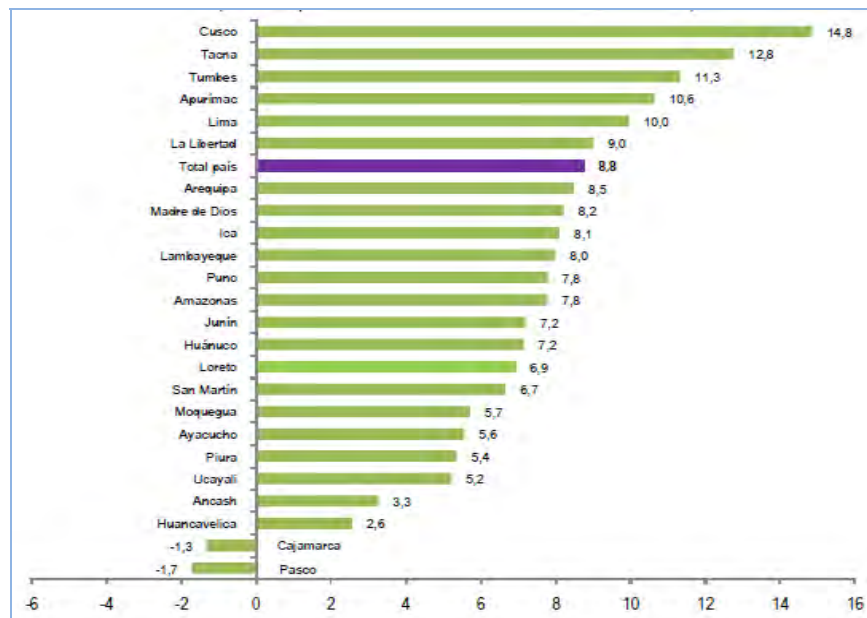

Fuente INEI – Dirección Nacional de Cuentas Nacionales-2010

Figure 3.1.2-1 Growth rate of GDP per region (2010/2009)

The table below shows the contribution of each region to the GDP. Lima Region represents almost half of the total, that is to say 45.0%. Arequipa contributed with 5.5 %, Piura 4.3 % and Ica 3.0 %. Taxes and duties contributed with 6.5 % and 0.3 %, respectively.

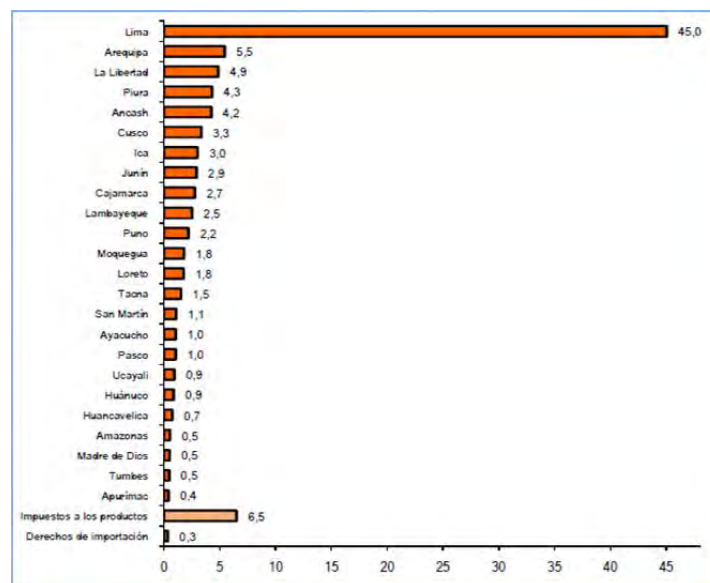

Fuente INEI – Dirección Nacional de Cuentas Nacionales-2010

Figure 3.1.2-2 Region contribution to GDP

The GDP per capita in 2010 was of S/.14,832 (5,727 US\$). The Table below shows data per region: Lima S/.19,573(7,557 US\$), Arequipa S/.19,575(7,558US\$), Ica S/.17,500(6,757US\$) show the higher value than national average, but Piura S/.10,585(4,087 US\$) is lower than the national average.

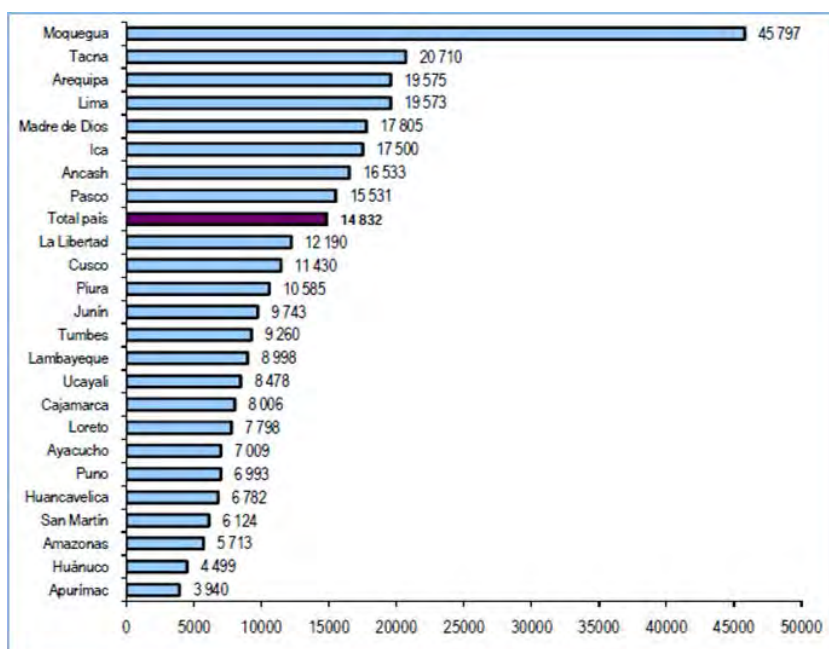

Fuente INEI – Dirección Nacional de Cuentas Nacionales-2010

Figure 3.1.2-3 GDP per capita (2010)

Table 3.1.2-7 shows the variation along the years of the GDP per capita per region, during the last 10 years (2001-2010).

The GDP national average increased in 54.8% within 10 years from 2001 until 2010. The Figures per region are: +96.6 % for Ica, +65.5 % for Arequipa, +55.2 % for Piura y +54.8 % for Lima. Figures in Table 3.1.2-7 were established taking 1994 as base year.

Table 3.1.2-7 Variation of the GDP per capita (2001-2009)

(1994 Base year, S/.)

Departamento	2001	2002	2003	2004	2005	2006	2007P/	2008P/	2009P/	2010E/	Variacion acumulada 2001-2010 (%)
Total país	4 601	4 765	4 890	5 067	5 345	5 689	6 121	6 643	6 625	7 124	54,8
Amazonas	1 835	1 910	1 996	2 081	2 212	2 349	2 510	2 684	2 761	2 959	61,3
Ancash	4 037	4 703	4 772	4 876	4 999	5 089	5 408	5 852	5 824	5 979	48,1
Apurimac	1 216	1 278	1 334	1 400	1 494	1 619	1 653	1 691	1 770	1 946	60,0
Arequipa	5 387	5 766	5 895	6 143	6 488	6 807	7 786	8 379	8 307	8 917	65,5
Ayacucho	1 788	1 870	1 942	1 900	2 045	2 207	2 448	2 640	2 896	3 020	68,9
Cajamarca	2 493	2 731	2 947	2 968	3 165	3 113	2 864	3 094	3 295	3 235	29,8
Cusco	2 194	2 086	2 195	2 565	2 768	3 071	3 340	3 554	3 685	4 202	91,5
Huancavelica	2 700	2 632	2 683	2 697	2 864	3 014	2 903	2 959	3 039	3 090	14,4
Huánuco	1 678	1 694	1 833	1 866	1 890	1 915	1 942	2 050	2 044	2 170	29,4
Ica	4 055	4 259	4 343	4 663	5 214	5 582	6 025	7 265	7 457	7 973	96,6
Junín	3 245	3 311	3 350	3 527	3 505	3 856	4 072	4 379	4 248	4 520	39,3
La Libertad	3 162	3 316	3 483	3 410	3 697	4 216	4 586	4 874	4 895	5 269	66,6
Lambayeque	2 941	3 046	3 132	2 959	3 164	3 300	3 615	3 882	3 963	4 240	44,2
Lima	6 451	6 579	6 700	6 925	7 284	7 817	8 520	9 314	9 219	9 990	54,8
Loreto	2 827	2 917	2 936	2 995	3 079	3 192	3 287	3 402	3 430	3 621	28,1
Madre de Dios	4 441	4 708	4 550	4 846	5 171	5 215	5 617	5 878	5 564	5 862	32,0
Moquegua	10 405	11 967	12 670	13 455	13 882	13 794	13 606	14 201	13 863	14 503	39,4
Pasco	5 137	5 552	5 481	5 634	5 644	6 062	6 711	6 729	6 349	6 187	20,4
Piura	2 733	2 780	2 847	3 049	3 192	3 472	3 780	4 007	4 059	4 241	55,2
Puno	2 105	2 236	2 234	2 270	2 365	2 460	2 617	2 731	2 800	2 992	42,1
San Martín	2 026	2 059	2 094	2 232	2 393	2 476	2 655	2 870	2 928	3 075	51,8
Tacna	6 004	6 124	6 382	6 643	6 782	6 941	7 256	7 458	7 256	8 067	34,4
Tumbes	2 744	2 802	2 873	3 018	3 385	3 212	3 427	3 594	3 611	3 957	44,2
Ucayali	3 063	3 149	3 203	3 411	3 584	3 754	3 846	4 007	4 040	4 190	36,8

Fuente INEI – Dirección Nacional de Cuentas Nacionales-2010

3.1.3 Agriculture

Next is a summarized report on the current situation of agriculture in the Watershed of the Chincha River, including irrigation commissions, crops, planted area, performance, sales, etc.

(1) Irrigation sectors

Table 3.1.3-1 shows basic data on the irrigation commissions. In the Watersheds of Matagente and Chico Rivers there are 3 irrigation sectors, 14 irrigation commissions with 7,676 beneficiaries. The surface managed by these sectors reaches a total of 25,629 hectares.

Table 3.1.3-1 Basic data of the irrigation commissions

Irrigation Sectors	Irrigation Commissions	Areas under irrigation		N° of Beneficiaries (Person)	River
		ha	%		
La Pampa	Chochocota	1.624	6 %	277	Matagente
	Belen	1.352	5 %	230	Matagente
	San Regis	1.557	6 %	283	Matagente
	Pampa Baja	4.124	16 %	596	Matagente
Chincha Baja	Matagente	2.609	10 %	421	Matagente
	Chillon	2.258	9 %	423	Matagente
	Rio Viejo	2.054	8 %	367	Matagente
	Chincha Baja	1.793	7 %	351	Matagente
Chincha Alta	Rio Chico	475	2 %	106	Chico
	Cauce Principal	1.644	6 %	456	Chico
	Pilpa	218	1 %	573	Chico
	Ñoco	1.227	5 %	1.428	Chico
	Aceqia Grande	1.077	4 %	1.520	Chico
	Irrigación Pampa de Ñoco	3.616	14 %	645	Chico
Total		25.629	100 %	7.676	

Source: Prepared by JICA Study Team, Users Board of Camana-Majes, September 2011

(2) Main crops

Table 3.1.3-2 shows the variation between 2004 and 2009 of the planted surface and the performance of main crops.

In the Chincha River Watershed, is increasing as planted area, performance and sales decreased. In the period 2008-2009 profits were of S/242,249,071. Main crops in this watershed were represented by: cotton, corn, grapes, artichokes and asparagus.

Table 3.1.3-2 Sowing and sales of main crops

	Variables	2004-2005	2005-2006	2006-2007	2007-2008	2008-2009
Cotton	Planted Area (ha)	10,217	11,493	10,834	11,042	8,398
	Unit performance (kg/Ha)	2,829	2,634	2,664	2,515	2,386
	Harvest (Kg)	28,903,893	30,272,562	28,861,776	27,770,630	20,037,628
	Unit Price (S/./kg)	2.19	2.21	2.82	2.65	1.95
	Sales (S/.)	63,299,526	66,902,362	81,390,208	73,592,170	39,073,375
Corn (yellow)	Planted Area (ha)	3,410	3,631	3,918	4,190	5,148
	Unit performance (kg/Ha)	7,585	7,460	7,640	7,860	8,286
	Harvest (Kg)	25,864,850	27,087,260	29,933,520	32,933,400	42,656,328
	Unit Price (S/./kg)	0.62	0.64	0.80	0.94	0.76
	Sales (S/.)	16,036,207	17,335,846	23,946,816	30,957,396	32,418,809
Grapes	Planted Area (ha)	1,589	1,271	1,344	1,411	1,325
	Unit performance (kg/Ha)	14,420	16,658	13,137	17,029	17,720
	Harvest (Kg)	22,913,380	21,172,318	17,656,128	24,027,919	23,479,000
	Unit Price (S/./kg)	0.92	1.06	1.40	1.54	1.66
	Sales (S/.)	21,080,310	22,442,657	24,718,579	37,002,995	38,975,140
Artichoke	Planted Area (ha)	587	896	993	777	1,426
	Unit performance (kg/Ha)	16,595	18,445	19,525	18,768	18,300
	Harvest (Kg)	9,741,265	16,526,720	19,388,325	14,582,736	26,095,800
	Unit Price (S/./kg)	0.93	1.00	1.10	1.17	1.20
	Sales (S/.)	9,059,376	16,526,720	21,327,158	17,061,801	31,314,960
Asparagus	Planted Area (ha)	903	860	855	776	1,102
	Unit performance (kg/Ha)	6,725	9,892	8,036	7,713	9,343
	Harvest (Kg)	6,072,675	8,507,120	6,870,780	5,985,288	10,295,986
	Unit Price (S/./kg)	2.81	3.08	2.93	3.04	2.79
	Sales (S/.)	17,064,217	26,201,930	20,131,385	18,195,276	28,725,801
Alfalfa	Planted Area (ha)	574	578	651	651	776
	Unit performance (kg/Ha)	16,871	21,645	29,926	39,072	44,161
	Harvest (Kg)	9,683,954	12,510,810	19,481,826	25,435,872	34,268,936
	Unit Price (S/./kg)	0.23	0.23	0.36	0.39	0.40
	Sales (S/.)	2,227,309	2,877,486	7,013,457	9,919,990	13,707,574
Avocado	Planted Area (ha)	347	347	638	703	938
	Unit performance (kg/Ha)	7,268	9,772	9,036	12,221	11,853
	Harvest (Kg)	2,521,996	3,390,884	5,764,968	8,591,363	11,118,114
	Unit Price (S/./kg)	1.30	1.51	1.75	2.08	2.25
	Sales (S/.)	3,278,595	5,120,235	10,088,694	17,870,035	25,015,757
Beets	Planted Area (ha)	408	553	539	522	777
	Unit performance (kg/Ha)	20,134	20,195	19,076	16,856	18,153
	Harvest (Kg)	8,214,672	11,167,835	10,281,964	8,798,832	14,104,881
	Unit Price (S/./kg)	0.16	0.33	0.22	0.44	0.43
	Sales (S/.)	1,314,348	3,685,386	2,262,032	3,871,486	6,065,099
Pumpkin	Planted Area (ha)	346	603	437	444	522
	Unit performance (kg/Ha)	31,021	30,992	30,925	30,582	32,939
	Harvest (Kg)	10,733,266	18,688,176	13,514,225	13,578,408	17,194,158
	Unit Price (S/./kg)	0.38	0.49	0.41	0.56	0.29
	Sales (S/.)	4,078,641	9,157,206	5,540,832	7,603,908	4,986,306
Tangerine	Planted Area (ha)	360	401	405	427	594
	Unit performance (kg/Ha)	25,918	27,493	33,723	31,727	34,887
	Harvest (Kg)	9,330,480	11,024,693	13,657,815	13,547,429	20,722,878
	Unit Price (S/./kg)	0.51	0.52	0.76	0.81	1.06
	Sales (S/.)	4,758,545	5,732,840	10,379,939	10,973,417	21,966,251
Others	Planted Area (ha)	2,434	1,897	2,161	1,830	1,994
Total	Planted Area (ha)	21,175	22,530	22,775	22,773	23,000
	Harvest (Kg)	133,980,431	160,348,378	165,411,327	175,251,877	219,973,709
	Sales (S/.)	142,197,073	175,982,668	206,799,102	227,048,475	242,249,071

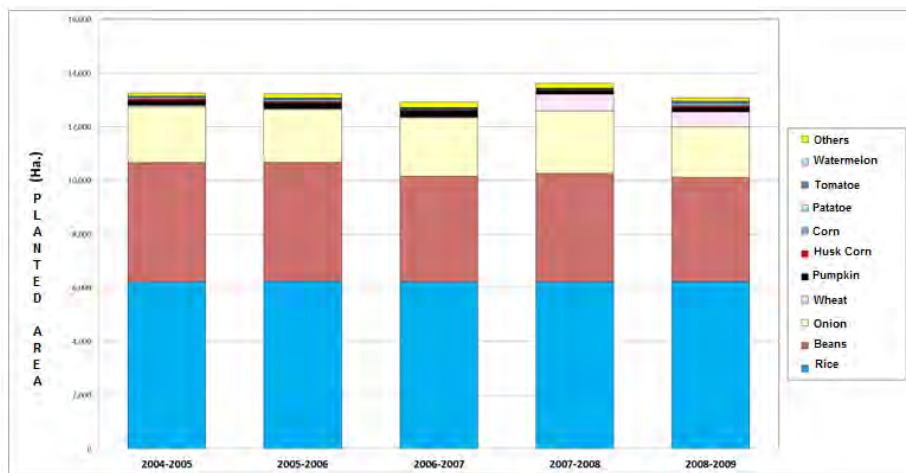

Figure 3.1.3-1 Planted surface

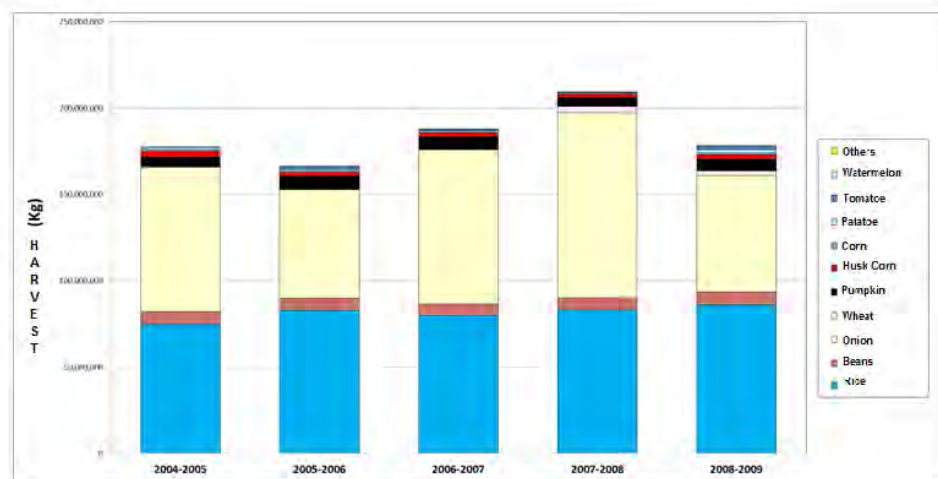

Figure 3.1.3-2 Harvest

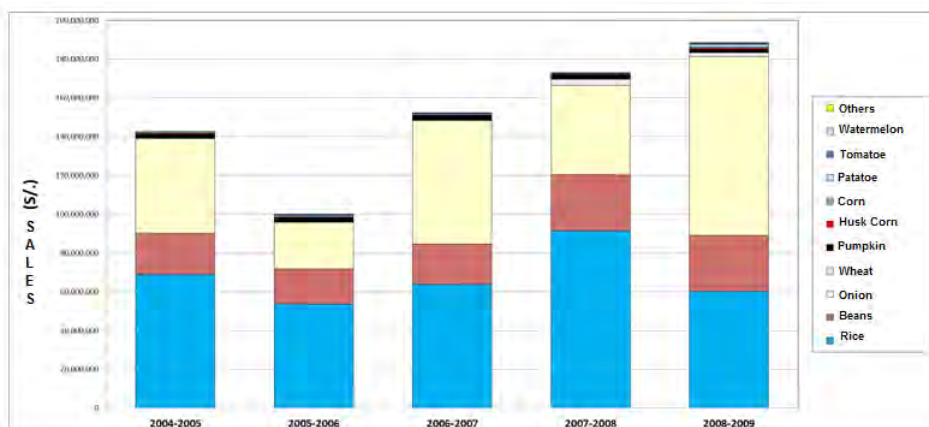

Figure 3.1.3-3 Sales

3.1.4 Infrastructure

(1) Road infrastructures

Table 3.1.4-1 shows road infrastructures in the watershed of the Chincha River. In total there are 453.27km of roads, 81,39km of them (18,0 %) are national roads, 227.16km (50,1%) regional roads, and 144.72km (31,9%) municipal roads.

From National roads, 40.75km are paved and in good state and the 40.64km that rest are in inadequate conditions.

From National roads, 20.02km are paved and in good state and the 207.14km that rest are in inadequate conditions

From National roads, 25.42km are paved and in good state and the 119.3km that rest are in inadequate conditions

Table 3.1.4-1 Basic data of road infrastructure

Roads	Total Length		Paving			
			Asphalted	Compacted	Non-	Soil
National roads	81.39	18.0%	40.75	40.64		
Regional roads	227.16	50.1%	20.02		207.14	
Municipal roads	144.72	31.9%	25.42		70.30	49.00
Total	453.27	100.0%	86.19	40.64	277.44	49.00

(2) PERPEC

Table 3.1.4-2 shows implemented projects by PERPEC between 2006 and 2009.

Table 3.1.4-2 Projects implemented by PERPEC

N°	Year	Work name	Location				Description	Total cost (\$/.)
			Department	Province	District	Town		
1	2006	Coastal defense of Chico River in Canyar	Ica	Chincha	Chincha	Canyar	Dike conformation 0.05 km	50,000.00
2	2006	Coastal defense of Chico River, Partidor Conta area	Ica	Chincha	Alto Laran	Partidos conta	Netting dike with cushion 0.23 Km	187,500.00
3	2007	Coastal defense of right bank Matagente River, ronceros alto area and on the left bank of Chico river in Ayacucho area, in Alto Laran district, Chincha province - Ica Region	Ica	Chincha	Chincha Baja	Chincha Baja	Dike with gavions and /or cushion 2.5 Km	517,979.00
5	2007	Channels rehabilitation of Alto Laran - High part Area	Ica	Chincha	Alto Laran	Huachinga Condores	Channel box rehabilitation 0.4768 Km	130,264.00
6	2007	Pampa Baja, Belen and Chococota channels cleanliness	Ica	Chincha	El Carmen	Pampa Baja, Belen , Chococota	Channel cleanliness 12.6278 Km	91,372.00
7	2008	Provisional coastal defense in Matagente River, La Pelota area, Del Carmen district and Ica Department (Contingency)	Ica	Chincha	El Carmen	La Pelota	Dike conformation with dragging material 1.5 Km	107,735.00
8	2008	Left and right banks coastal defense of Chico River, Canyar Area, Chincha Baja district, Chincha Province, Ica Region (Contingency)	Ica	Chincha	Chincha	Canyar	Dike conformation with coating of anti-scouring cushion 850 ml	695,900.00
9	2008	Coastal defense of Matagente River, Punta La Isla - Ronceros Alto - Ganaderos Los Angeles Areas, El Carmen district, Chincha Province, Ica Region (Prevention)	Ica	Chincha	El Carmen	La Isla - Ronceros Alto - Ganaderos Los Angeles	Rockfill dike 1460 ml	583,294.00
10	2009	Coastal defense on the right bank of Chico River, El Taro area, Alto Laran district, Chincha province, Ica region	Ica	Chincha	Alto Laran	Chamorro, Atahualpa	Netting dike of Chico River 200 ml	290,222.00

3.1.5 Real Flood Damages

(1) Damages on a nationwide scale

Table 3.1.5-1 shows the present situation of flood damages during the last five years (2003-2007) in the whole country. As observed, there are annually dozens to hundreds of thousands of flood affected inhabitants.

Table 3.1.5-1 Situation of flood damages

		Total	2003	2004	2005	2006	2007
Disasters	Casos	1,458	470	234	134	348	272
Victims	personas	373,459	118,433	53,370	21,473	115,648	64,535
Victims dof housing	personas	50,767	29,433	8,041	2,448	6,328	4,517
Dead	personas	46	24	7	2	9	4
Partially destroyed housings	Housing	50,156	17,928	8,847	2,572	12,501	8,308
Totally destroyed housings	Housing	7,951	3,757	1,560	471	1,315	848

Source : Compendio estadísticos de SINADECI

Peru has been hit by big torrential rain disasters caused by the El Niño Phenomenon. Table 3.1.5-2 shows damages suffered during the years 1982-1983 and 1997-1998 with extremely serious effects. Victims were approximately 6,000,000 inhabitants with an economic loss of about US\$ 1,000,000,000 in 1982-1983. Likewise, victims number in 1997-1998 reached approximately 502.461 inhabitants with economic loss of US\$ 1,800,000,000. Damages in 1982-1983 were so serious that they caused a decrease of 12 % of the Gross National Product.

Table 3.1.5-2 Damages

Damages	1982-1983	1997-1998
Persons who lost their homes	1.267.720	—
Victims	6.000.000	502.461
Injured	—	1.040
Deceased	512	366
Missing persons	—	163
Partially destroyed houses	—	93.691
Totally destroyed houses	209.000	47.409
Partially destroyed schools	—	740
Totally destroyed schools	—	216
Hospitals and health centers partially destroyed	—	511
Hospitals and health centers totally destroyed	—	69
Damaged arable lands (ha)	635.448	131.000
Head of cattle loss	2.600.000	10.540
Bridges	—	344
Roads (km)	—	944

Damages	1982-1983	1997-1998
Economic loss (\$)	1.000.000.000	1.800.000.000

“-“: No data

(2) Disasters in the watersheds object of this study

Table 3.1.5-3 summarizes damages occurred in the Ica region, that the presents study is part of.

Table 3.1.5-3 Disasters in the Ica region

Years	1995	1996	1997	1998	1999	2000	2001	2002	2003	2004	2005	2006	2007	2008	2009	2010	Total	Media
Landslip																	0	
Flood																	0	
Collapse											2						2	
Landslide									2	1				1			4	
Avalanche	2		2		5	2				2	1	1	3	1		1	20	
TOTAL SEDIMENT DISASTERS	2	0	2	0	5	2	0	0	2	3	3	1	3	2	0	1	26	2
TOTAL FLOODS	4	4	0	13	14	1	2	0	0	1	1	0	4	6	1	0	51	3

3.1.6 Results on the Visits to Study Sites

JICA Study Team made some technical visits to the selected watersheds and identified some challenges on flood control through visits and interviews to regional government authorities and irrigation associations on damages suffered in the past and the problems each watershed is currently facing.

(1) Interviews

(Critical conditions)

- The stream has only a capacity of 100m³/s to flow, and when overflowing of 1.200 m³/s happened, the river overflowed
- Basically, the river's water must be derived in a relation 1:1, and this relation is changed when overflowing occurs. If these can be adequately maintained regarding its derivation, the problem would be solved
- There are 2 critical sections: Km15 of Chico River and Km16 of Matagente River
- There is a 16Km section (between Km 10 and 16) of Matagente River that is very sedimented, this may lead to an overflow
- Chico River overflows on curvy section on Km 15
- The overflow water floods very quickly up to the lower watershed due to the local slope
- When the three intakes stop working, the producers can not irrigate their lands
- The three intakes were built in 1936. The derivation works in the upstream extreme was built in 1954
- River has water from January to March; the rest of time, from groundwater
- There are 7 reservoirs at 180km upstream, with a total capacity of 104×10⁶m³. The water is collected between January and July and is given since August
- According to the Water Society President, Matagente River overflowing was a problem more

than 20 years ago since he lives in the area. The bed is continuing to rise at a 4 to 5 meters pace in the last 50 years. A dike was built to control overflowing

- The problem takes place annually, since December until the end of March. Every year, 10 floods of 5 to 6 hours each take place (max 12 hours). When floods are frequent, derivation works are obstructed on one side and this overflows water
- It is a elevated bed river
- All the upper watershed area is constituted by collapse area
- The overflow water from the river returns to it through local channels
- Sometimes, channels overflow water leads to flood in Chincha
- Main products are cotton and grapes
- The stream is measures by upstream derivation works

(Other: visited sites by the Study Team)

- Chamorro Bridge (Matagente River)
 - Finish built in 1985
- Matagente Bridge (Matagente River)
 - Built to allow a 200m³/s flow (initially projected for 550m³/s)
 - There is a project to elongate the dike until the flood area downstream
- Intake (Matagente River)
 - Water intake is between January and March
 - All the water is taken, this River is depleted in this season. Since dam's water is been taken, there is no need to stop flowing downstream
- Chico River Intake (Chico River)
 - There is a purifying plant, but currently it is not working

(2) Description of the visit to the study sites

Figure 3.1.6-1 shows pictures of main sites visited.

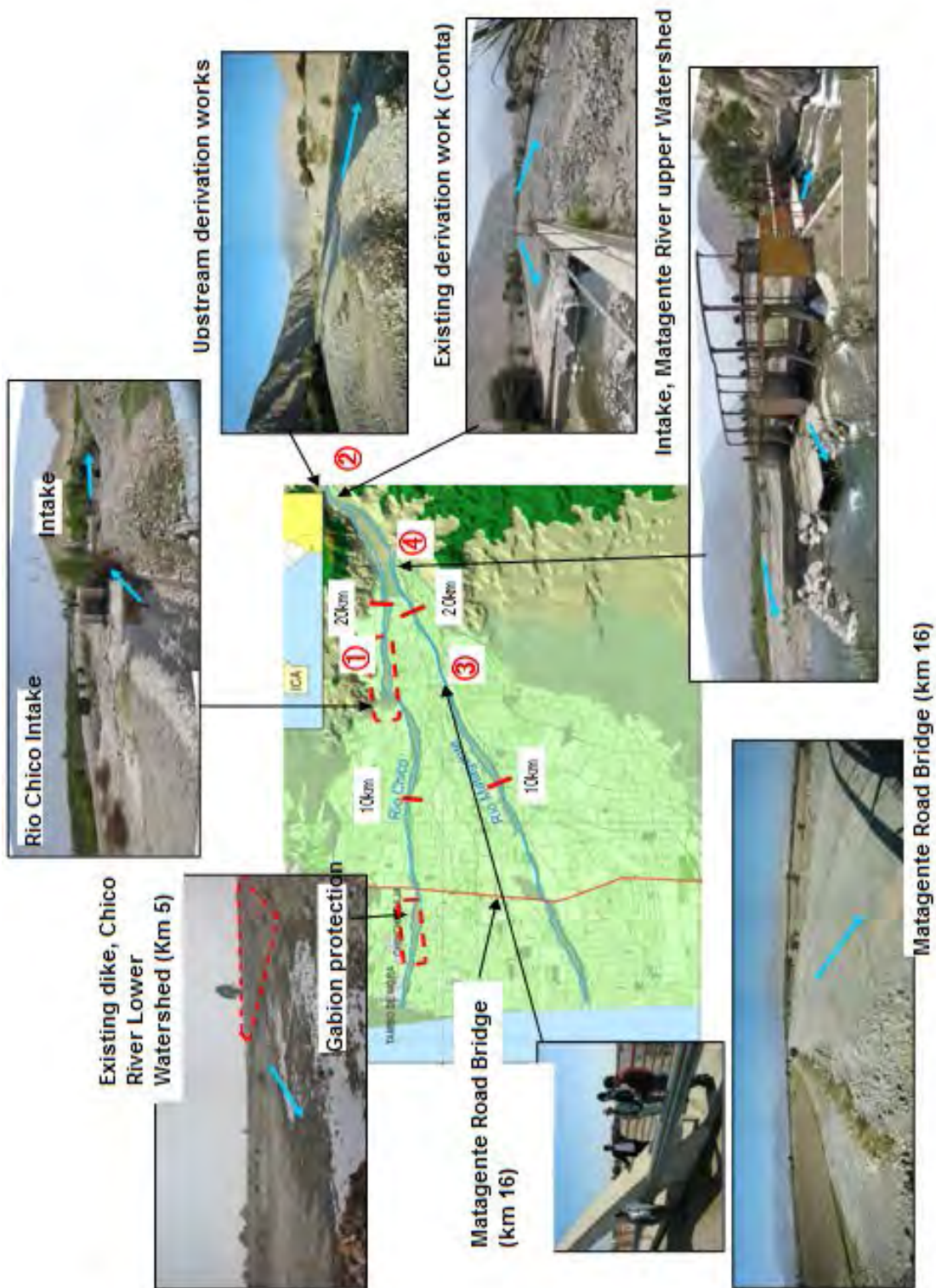

Figure 3.1.6-1 Visit to the study site (Chincha river)

(3) Challenges and measures

The following table shows challenges and possible solution measures for flood control considered at this moment, based on the results of technical visits.

1) Challenge 1: Derivation works (Km 24) (Conta weir : Free diversion type with training dike and free overflow weir, without reference materials such as drawings)

Current situation and challenges	<ul style="list-style-type: none"> • The problem appears annually from December until March. Ten floods of 5 to 12 hours take place. Maximum flow in El Niño reached 1.200 m³/s. • According to the design, the river's water shall be derived in a relation of 1:1, and this Lumber is changed when frequent floods take place causing Downstream water overflow.
Main elements to be conserved	<ul style="list-style-type: none"> • Lower watershed crop area • Urban Area of Chincha
Basic measures	<ul style="list-style-type: none"> • Rehabilitation of destroyed installations and existing dikes reinforcement • Extend longitudinal dike upstream of the intake • Channels rehabilitation upstream of the intake • The discharge control method with gate is difficult to be adopted from view point of operation and maintenance work and construction cost.

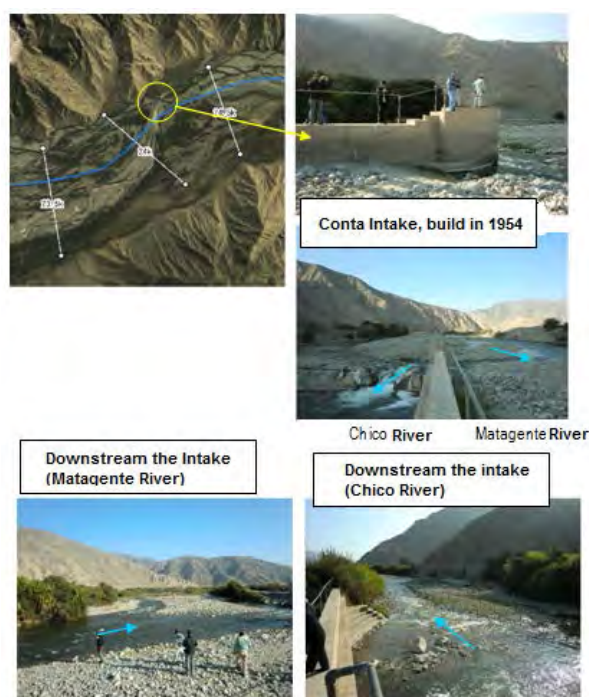

Figure 3.1.6-2 Local conditions related with Challenge 1 (Chincha river)

2) Challenge 2: Intake (km 21 of Matagente)

Current situation and challenges	<ul style="list-style-type: none"> • La toma de agua se realiza entre enero y marzo. La obra fue construida en 1936. • Es una de las bocatomas más importantes de la zona. • El delantal de la bocatoma se encuentra gravemente destruido, pudiendo destruir la misma presa de no tomarse medidas adecuadas.
Main elements to be conserved	<ul style="list-style-type: none"> • Lower basin crop land (main products: cotton and grapes)
Basic measures	<ul style="list-style-type: none"> • Compact the bed immediately Downstream the deteriorate intake, repair the longitudinal dike and reinforce the existing dike



Figure 3.1.6-3 Local conditions related with Challenge 2 (Chincha river)

3) Challenge 3: Intake (Rio Chico, km 15)

Current situation and challenges	<ul style="list-style-type: none"> • Water intake is in January through March. This was built in 1936 • In the past water has overflow on the left bank • Channel width is reduced near the intake, gathering overflows in this area
Main elements to be conserved	<ul style="list-style-type: none"> • Lower basin crop land (main products: cotton and grapes)
Basic measures	<ul style="list-style-type: none"> • Rehabilitate the existing dike (repair and reinforce deteriorate parts of the dam) • Stable scour of overflows through increase and rehabilitation of channels

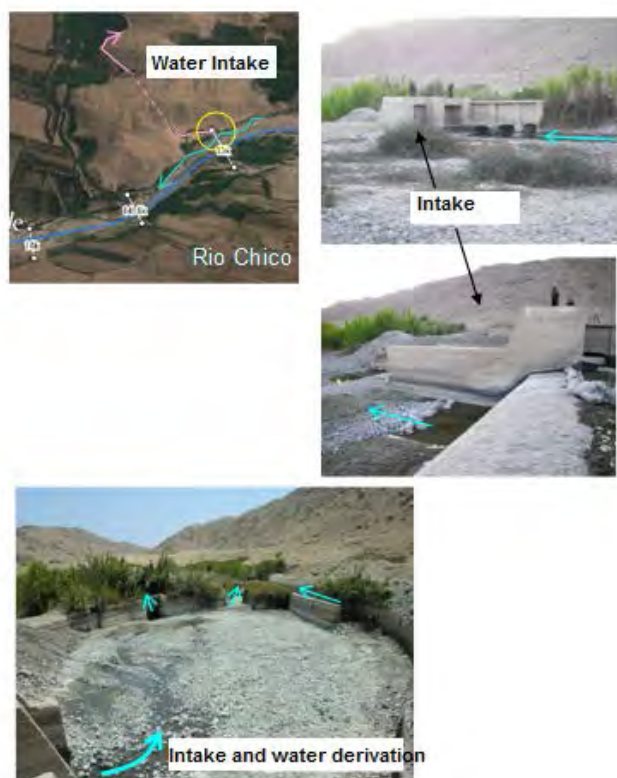

Figure 3.1.6-4 Local conditions related with Challenge 3 (Chincha river)

3.1.7 Current Situation of Vegetation and Reforestation

(1) Current vegetation

The most recent information about the classification of vegetation is that carried out by FAO on 2005, with the collaboration of National Institute of Natural Resources of the Ministry of Agriculture (INRENA¹ in Spanish). According In this study the 1995 Forest Map was used as database and its Explanatory Guide prepared by INRENA and the Forest General Direction. Likewise, the National Planning Institute and the National Bureau of Natural Resources Evaluation (ONERN in Spanish) prepared the Budget, Evaluation and Use of Natural Resources of the Coast which describes the classification of the vegetation and the coast flora.

Pursuant to the 1995 Forest Map and its explanations, the Chincha watershed extends from the coast to the Andean mountains; usually, featuring different vegetal coverage according to the altitude. From coast up to the 2,500 m.a.s.l (Cu, Dc) have scarce vegetation. Some meters above in altitude, some scrubland can be noticed. Among 2500 and 3500 m.a.s.l there are only scarce bushes disseminated in the area due to the rains. These bushes disappear due to the low temperatures and are seen again in the herbaceous areas. In the bush area the maximum height of tree is about 4 m. However, in zones close to the rivers, high trees have grown, even in arid zones.

Table 3.1.7-1 List of representative vegetable forming in the watersheds extending from the coast to the Andean mountains

Symbol	Life Zone	Distribution of Altitude	Rainfall	Representative Vegetation
1)Cu	Coast Crop Lands	Coast	Almost none.	Coastal crops
2)Dc	Coast Desert	0~1,500 m.a.s.l	Almost none, there are mist zones.	Almost none, there are vegetation slopes
3)Ms	Dry Thicket	1,500~3,900 m.a.s.l	120~220mm	Cactus and grass
4)Msh	Subhumid Forest	North-center: 2,900~3,500 m.a.s.l Inter Andean 2,000~3,700 m.a.s.l	220~1,000mm	Perennial bushes, less than 4m high
5)Mh	Humid Forest	North: 2,500~3,400 m.a.s.l South 3,000~3,900 m.a.s.l	500~2,000mm	Perennial bushes, less than 4m high
6)Cp	Puna grass	Approx 3,800 m.a.s.l	No description	Gramineae
7)Pj	Scrubland	3,200~3,300 m.a.s.l Center-South up to 3,800 m.a.s.l	South zone with low rainfall: less than 125mm East springs: higher than 4,000mm	Gramineae
8)N	Ice-capped mountains		—	—

Source: Prepared by the JICA Team base don the Forest Map. 1995

(2) Area and distribution of vegetation

The present study was determined by the surface percentage that each vegetation formation occupies on the total watershed's surface, overcoming the INRENA study results of 1995 to the GIS (see Tables 3.1.7-2 and Figures 3.1.7-1). Then, the addition of each ecologic life zone's surface, outstanding the coastal desert (Cu, Pj) dry bushes (Ms) and puna grass (Cp, Pj) was calculated. In Table 3.1.7-3 it is shown the percentage of each ecologic area. It is observed that the desert occupies 30% of the total area, 10% or 20% of dried grass and puna grass 50%. Bushes occupy between 10 to 20%. They are

¹ Subsequently, INRENA was dissolved and its functions were assumed by the Wild Forest and Fauna General Direction.

distributed on areas with unfavorable conditions for the development of dense forests, due to which the surface of these bushes is not wide. So, natural conditions of the four watersheds of Chincha River are set. In particular, the low precipitations, the almost non-fertile soil and accentuated slopes are the limiting factors for the vegetation growth, especially on high size species.

Table 3.1.7-2 Area of each classification of vegetation (Chincha River watershed)

Watersheds	Vegetation								
	Cu	Dc	Ms	Msh	Mh	Cp	Pj	N	Total
(Surface: hectares)									
Chincha River	169,98	1.010,29	642,53	365,18	0,00	854,74	261,17	0,00	3.303,89
(Percentage of the watershed surface: %)									
Chincha River	5,1	30,6	19,4	11,1	0,0	25,9	7,9	0,0	100,0

Source: Prepared by the JICA Team based on the INRENA1995 Forest Map of

Table 3.1.7-3 Area and percentages of each classification of vegetation gathered (Chincha river watershed)

Watershed	Ecologic Zones					
	Desert,etc. (Cu, Dc)	Dry bushes (Ms)	Bushes (Msh, Mh)	Grass (Cp, Pj)	Snowy (N)	Total
(Percentage: %)						
Chincha	35.7	19.4	11.1	33.8	0.0	100.0

(3) Forest area variation

Although a detailed study on the variation of the forest area in Peru has not been performed yet, the National Reforestation Plan Peru 2005-2024, Annex 2 of INRENA shows the areas deforested per department until 2005. These areas subject matter of this study are included in the regions of Arequipa, Ayacucho, Huancavelica, Ica, Lima and Piura, but they only belong to these regions partially. Table 3.1.7-4 shows the Figures accumulated areas deforested in these regions. However, in relation to the Ica Region, data are not available.

Table 3.1.7-4 Area deforested Until 2005

Department	Area (ha)	Area deforested accumulated (ha) and the percentage of such area in the department area (%)	Post-Felling Situation	
			Non used Area (ha)	Used area(ha)
Ica	2.093.457	-	-	-

Source: National Reforestation Plan, INRENA, 2005

The variation of the distribution of vegetation was analyzed per watershed, comparing the SIG to the data from the FAO study performed in 2005 (prepared based on satellite figures from 2000) and the results of the 1995 INRENA study (prepared base on satellite figures from 1995). (See Table 3.1.7-5).

Analyzing the variation of the surface of each vegetation formation, it is observed that the vegetation has reduced in the arid zones (desert and cactus: Cu, DC and Ms) and bushes (Msh, Mh), puna grass (Cp) and Ice-capped (N) increased.

**Table 3.1.7-5 Changes in the areas of distribution of vegetation from 1995 to 2000
(Chincha river watershed)**

Watershed	Vegetation Formation								
	Cu		Cu		Cu		Cu		Cu
(Surface of the vegetation cover: hectare)									
Chincha	-5,09	-19,37	-95,91	86,85	3,55	-5,54	35,51	—	3.303,89
Current Surface (b)	169,98	1,010,29	642,53	365,18	0,00	854,74	261,17	0,00	3.303,89
Percentage of current surface (a/b) %	-3,0	-1,9	-14,9	+23,78	—	-0,6	+13,6	—	

Source: Prepared by the JICA Study Team based on the studies performed by the INRENA 1995 and FAO 2005

(4) Current situation of forestation

As indicated before, the climate conditions of Chincha River watershed do not improve high trees species development, so natural vegetation is not distributed; this only happens in the margins where the freatic water table is near the surface. So, due to the difficult situation of finding a good spot to grow trees is why reforestation great projects have not happened in this area. There is no reforest project known with commercial aims.

In the lower and medium watersheds, trees are planted mainly for three objectives: i) reforest along the river to prevent disasters; ii) for agricultural lands protection from wind and sand; and iii) as perimeter for housings. In any case, the surface is much reduced. The most planted specie is Eucalyptus and is followed by *Casuarinaceae*. The use of native species is not very common. On the other hand, in the Mountain region, reforesting is done for logging, crops protection (against cold and livestock entrance) and to protect the recharge water areas. There are mostly eucalyptus and pines. Many reforest projects in the Mountain region have been executed following PRONAMACHS (currently, AGRORURAL). Such program gives throughout AGRORURAL seedlings to the community, which are planted and monitored by producers. There is also a reforest program implemented by the regional government, but in a very reduced way. In this case, the program establishes the needs to achieve consensus from the community to choose the areas to be reforested. However, in general, mostly all farmers want to have greater crop lands and achieving consensus always takes more time. Another limiting factor is the cold weather on altitudes greater than 3,800m.a.s.l. In general, no information has been able to be collected on reforestation projects to date, because these files were not available.

The National Reforestation Plan (INRENA, 2005) registers forestation per department from 1994 to 2003, from which the history data corresponding to the environment of this study was searched (See Table 3.1.7-6). It is observed that the reforested area increased in 1994, drastically decreasing later. Arequipa, Ica and Lima are departments located in the coast zone with scarce rainfall, thus the forestation possibility is limited, besides the scarce forest demand.

Table 3.1.7-6 History registry of forestation 1994-2003 (Units: ha)

Department	1994	1995	1996	1997	1998	1999	2000	2001	2002	2003	Total
Ica	2.213	20	159	159	89	29	61	15	4	1	2.750

Source: National Reforestation Plan, INRENA, 2005

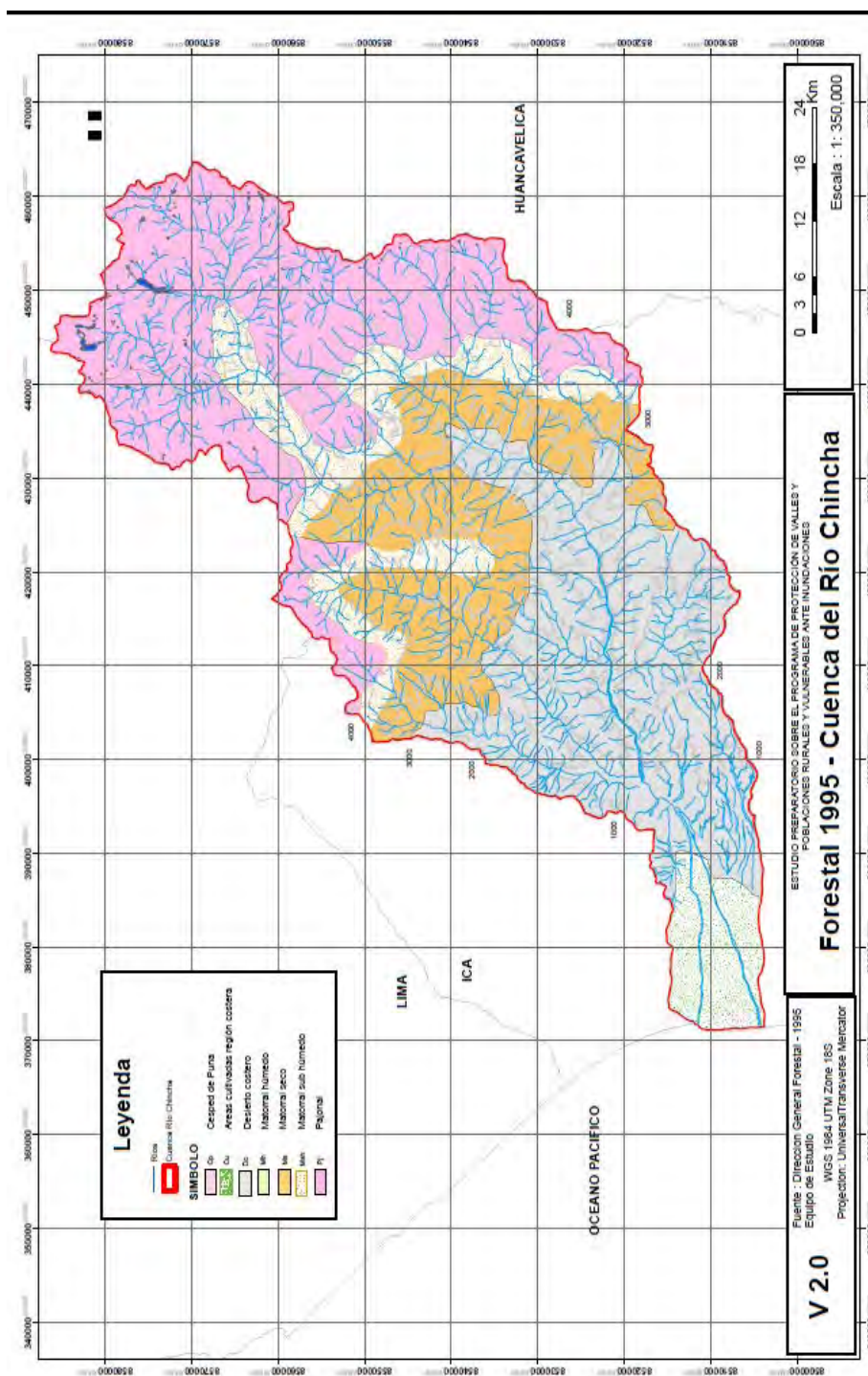

Figure 3.1.7-1 Chincha river forestry map

3.1.8 Current Situation of the Soil Erosion

(5) Information gathering and basic data preparation

1) Information gathering

During this study the data and information indicated in Table 3.1.8-1 was collected in other to know

the current situation of the sediment production behind the Study Area.

Table 3.1.8-1 List of collected information

	Forms	Prepared by:
Topographic map (Scale 1/50.000)	Shp	INSTITUTO GEOGRAFICO NACIONAL
Topographic map (Scale 1/100.000)	Shp,dxf	INSTITUTO GEOGRAFICO NACIONAL
Topographic map (Scale 1/250.000)	SHP	Geologic data systems
Topographic map (Scale 1/100.000)	Shock Wave	INGEMMET
30 m grid data	Text	NASA
River data	SHP	ANA
Watershed data	SHP	ANA
Erosion potential risk map	SHP	ANA
Soils map	SHP	INRENA
Vegetal coverage map	SHP2000 PDF1995	DGFFS
Rainfall data	Text	Senami

2) Preparation of basic data

The following data was prepared using the collected material. Details appear in Annex 6.

- Hydrographic watershed map (zoning by third order valleys)
- Slope map
- Geological Map
- Erosion and slope map
- Erosion and valley order map
- Soil map
- Isohyets map

(6) Analysis of the causes of soil erosion

1) Topographic characteristics

i) Surface pursuant to altitudes

Table 3.1.8-2 and Figure 3.1.8-1 show the percentage of surface according to altitudes of Chincha River watershed.

Table 3.1.8-2 Surface according to altitude

Altitude (msnm)	Area (k m ²)
	Chincha
0 – 1000	435,6
1000 – 2000	431,33
2000 – 3000	534,28
3000 – 4000	882,39
4000 – 5000	1019,62
5000 – More	0,67

TOTAL	3303,89
Maximum Altitude	5005,00

Source: Prepared by the JICA Study Team based on the 30 m grid data

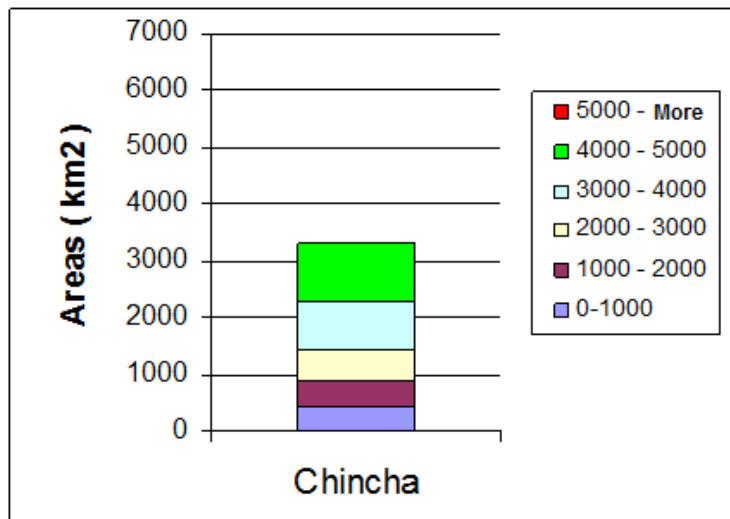

Figure 3.1.8-1 Surface according to altitude

ii) Zoning according to slopes

Table 3.1.8-3 and Figure 3.1.8-2 show the slopes in Chincha River watershed. In Chincha slopes of more than 35° represent more than 50% of the total surface. The more pronounced topography, the more sediments production value. So, more sediment is produced.

Table 3.1.8-3 Slopes and surface

Watershed slope (%)	Chincha	
	Area (km ²)	Area (km ²)
0 - 2	90,62	90,62
2 - 15	499,68	499,68
15 - 35	1019,77	1019,77
More than 35	1693,82	1693,82
TOTAL	3303,89	3303,89

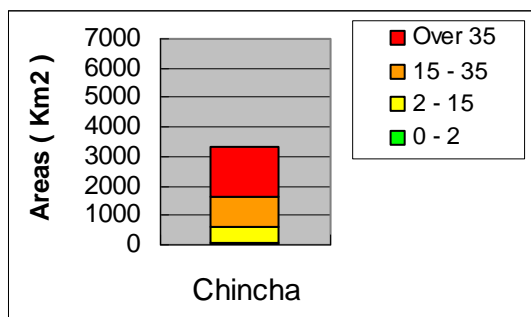

Figure 3.1.8-2 Slopes and surface

iii) River-bed slope

Table 3.1.8-4 and Figure 3.1.8-3 show the slope in every river and the length of streams including tributaries. Figure 3.1.8-4 shows the general relation of the movement of sediments and the river-bed slope. Supposedly, sections with more than 33,3 % of slope tend to produce higher amount of sediments.

Table 3.1.8-4 River-bed slope and total length of stream

River-bed slope (%)	Chincha
0,00 - 1,00	5,08
1,00 - 3,33	177,78
3,33 - 16,67	1250,82
16,67 - 25,00	458,76
25,00 - 33,33	255,98
33,33 – More	371,8
TOTAL	2520,22

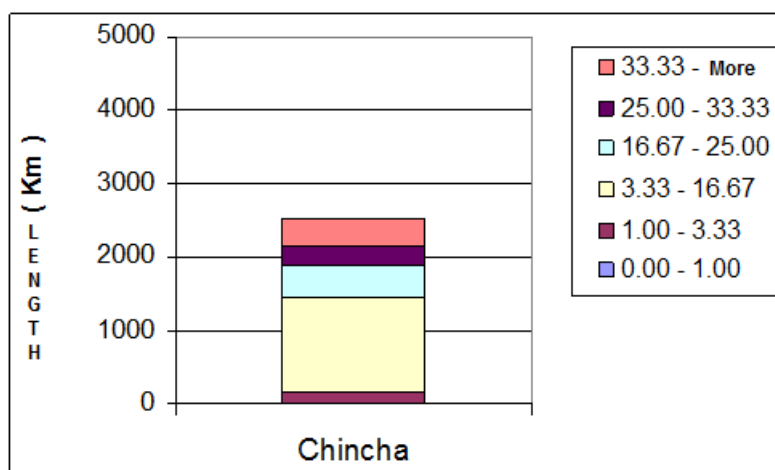

Figure 3.1.8-3 River-bed slope and total length of streams

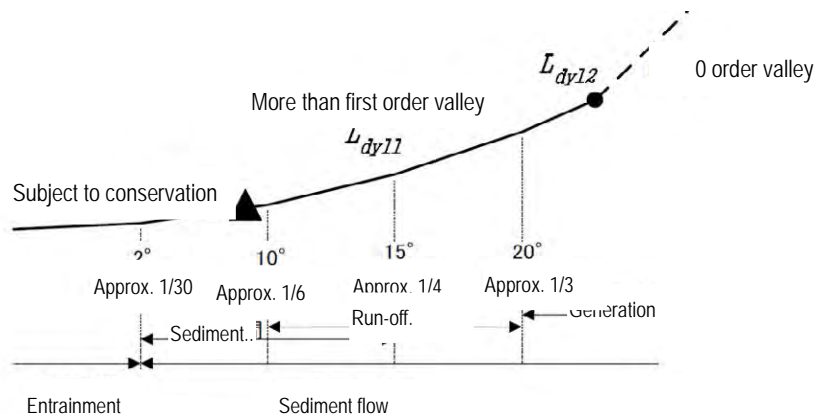
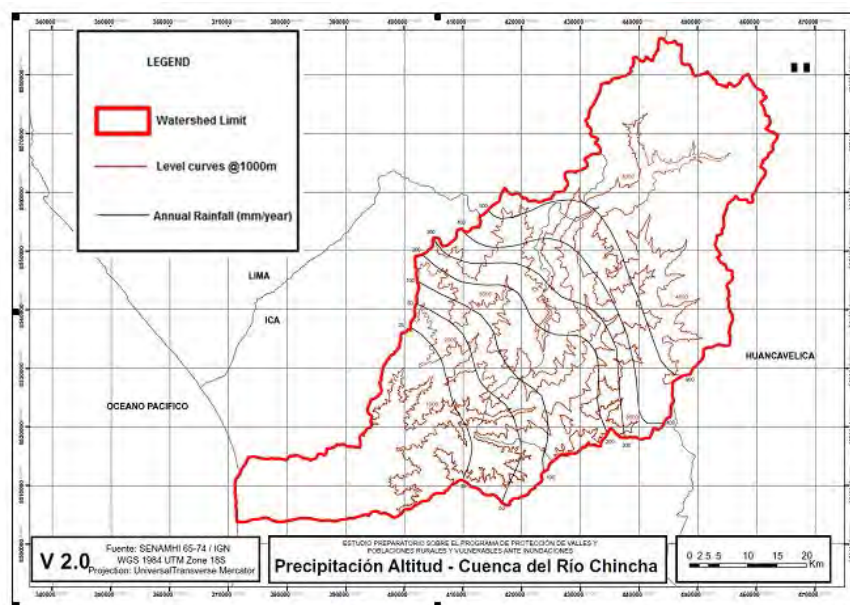

Figure 3.1.8-4 River-bed slope and sediment movement pattern

2) Rainfall

On the Pacific coast there is an arid area of 30 to 50km width and approx 3.000km long. This region belongs to a climate zone called Chala, where the middle annual temperature is about 20 °C and almost it does not rain along the year.

Altitudes between 2500 and 3000 m.a.s.l. belong to the Quechua zone, where annual precipitation exist between 200 and 300mm. On altitudes from 3500 and 4500m.a.s.l there is another region, called Suni, characterized by its sterility. Precipitations in this region occur annually with 700mm of rain. Figure 3.1.8-5 shows the isohyets map (annual rainfall) of each watershed.



Source: Prepared by the JICA Study Team based on the SENAMHI data

Figure 3.1.8-5 Isohyet map of the Chincha river watershed

Annual precipitations in the flood analysis area fluctuate between 0 and 25mm. The average annual precipitation in the northern area of 4000m.a.s.l is between 750 and 100 m.a.s.l.

3) Erosion

The characteristics of erosion of the watershed in general are presented below. This is divided in three large natural regions: Coast, Mountain/Suni and Puna. Figure 3.1.8-6 shows the corresponding weather and the rainfalls. It is observed that the area most sensitive to erosion is Mountain/Suni where the pronounced topography without vegetal coverage predominates.

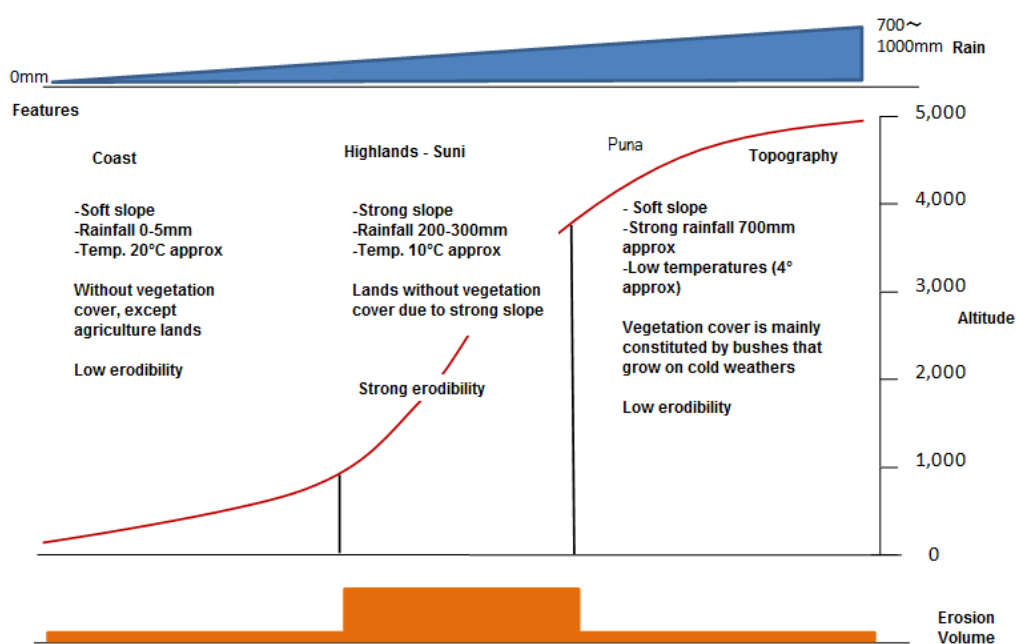

Figure 3.1.8-6 Relation between the erosion volume and the different causes

(7) Identification of the zones more vulnerable to erosion

The erosion map prepared by ANA considers the geology, hill sloping and rainfalls. Supposedly, the erosion depth depends on the hillside slope, and in such sense the erosion map and the slope map are consistent. Thus, it is deduced that the zones more vulnerable to erosion according to the erosion map are those where most frequently erosion happens within the corresponding watershed.

Between 2000 and 5000 m.a.s.l are located on slopes with more than 35 %. It is observed that more than approximately 60% of the watershed is constituted by slopes with these inclinations. In particular, between 1000 and 3000 more than 80% of slopes are more than 35% and are deduced to be more susceptible to erosion.

Table 3.1.8-5 Slopes according to altitudes of the Chincha river watershed

Altitude	SLOPES				Total
	0-2	2 - 15	15 - 35	More than 35	
0 - 1000	78.15	80.09	148.11	129.25	435.6
Ratio	18%	18%	34%	30%	100%
1000 - 2000	0	50	234.91	146.42	431.33
Ratio	0%	12%	54%	34%	100%
2000 - 3000	0	47.83	64.87	421.58	534.28
Ratio	0%	9%	12%	79%	100%
3000 - 4000	0	32.12	256.02	594.25	882.39
Ratio	0%	4%	29%	67%	100%
4000 - 5000	12.47	289.52	315.65	401.98	1019.62
Ratio	1%	28%	31%	39%	100%
5000 - More	0	0.12	0.21	0.34	0.67
Ratio	0%	18%	31%	51%	100%
Total	90.62	499.68	1019.77	1693.82	3303.89
Ratio	3%	15%	31%	51%	100%

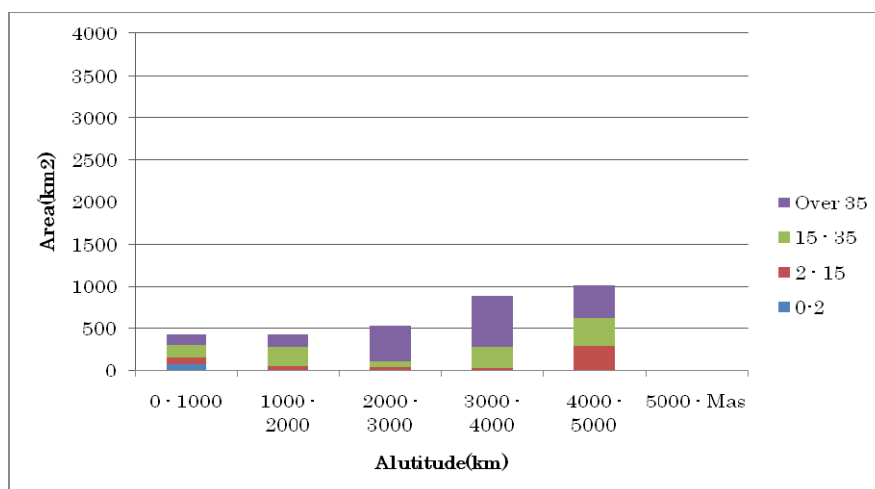

Figure 3.1.8-7 Slopes according to altitudes of Chincha river

(8) Production of sediments

1) Results of the geological study

- On mountain slopes there are formations of clastic deposits leaved by collapses or wind erosion
- Production patterns are differentiated according to the foundation rock geology. If this foundation is andesitic or basaltic, the mechanisms consists mainly in great gravel falling (see Figure 3.1.8-8 and 3.1.8-9)
- There is no rooted vegetation (Figure 3.1.8-10) due to the sediment in ordinary time. On the joints of the andesitic rock layer where few sediment movements occur, algae and cactus have developed
- In almost every stream lower terrace formation was observed. In these places, sediments dragged from slopes do not enter directly to the stream, but they stay as deposits on the terraces. Due to this, most of the sediments that enter the river probably are part of the deposits of the erosion terraces or accumulated sediments due to the bed's alteration (see Figure 3.1.8-11)
- On the upper watershed there are less terraces and the dragged sediments of slopes enter directly to the river, even though its amount is very little



Figure 3.1.8-8 Andesitic and basaltic soil collapsed



**Figure 3.1.8-9 Sediment production
of sedimentary rocks**



Figura 3.1.8-10 Invasión de cactus

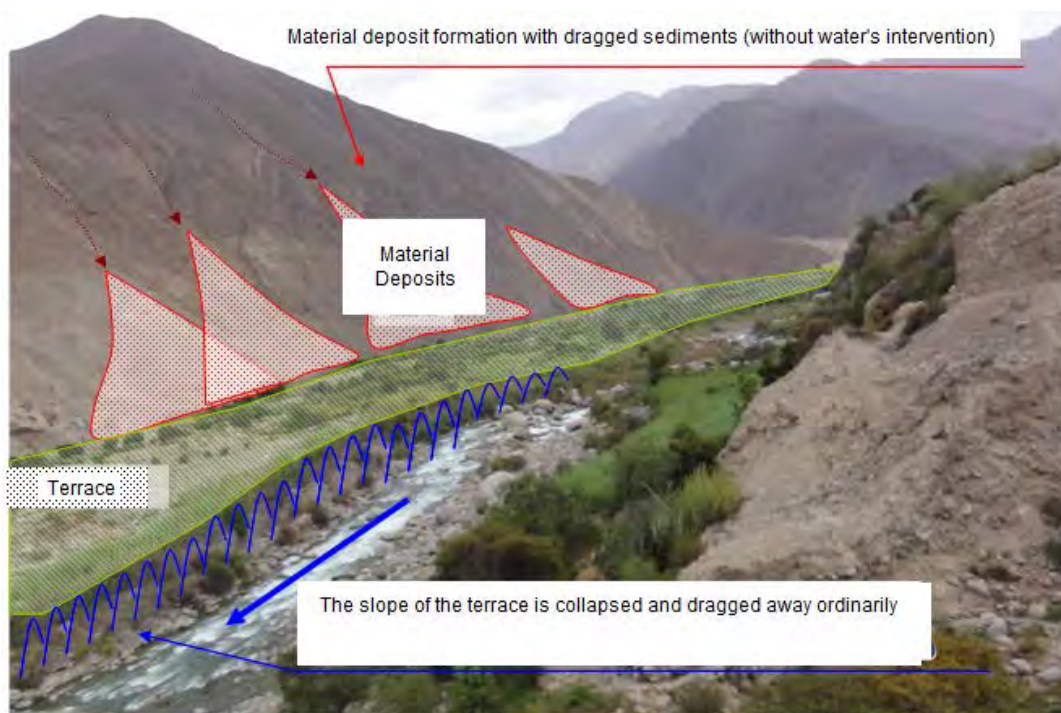

Figure 3.1.8-11 Stream sediment movement

2) Sediments movement (in the stream)

In ravines, terraces are developed. The base of these terraces is directly contacted with channels and from these places the sediments will be dragged and transported with an ordinary stream (including small and medium overflows in rainy season).

3) Production forecast and sediments entrainment

It is expected that the amount of sediment production and entrainment will vary depending of the dimension of factors such as rainfall, volume of flow, etc.

Since a quantitative sequential survey has not been performed, nor a comparative study, here we show some qualitative observations for an ordinary year, a year with a rainfall similar to that of El Niño and one year with extraordinary overflow. The scope of this Study is focused on a rainfall with 50 year return period, as indicated in the Figure below, which is equivalent to the rainfall producing the sediment flow from the tributaries.

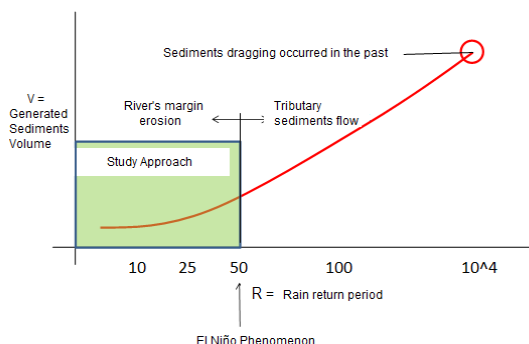

i) An ordinary year

- Almost no sediments are produced from the hillsides
- Sediments are produced by the encounter of water current with the sediment deposit detached from the hillsides and deposited at the bottom of terraces
- It is considered that the entrainment is produced by this mechanism: the sediments accumulated in the sand banks within the bed are pushed and transported downstream by the bed change during low overflows (see Figure 3.1.8-12)

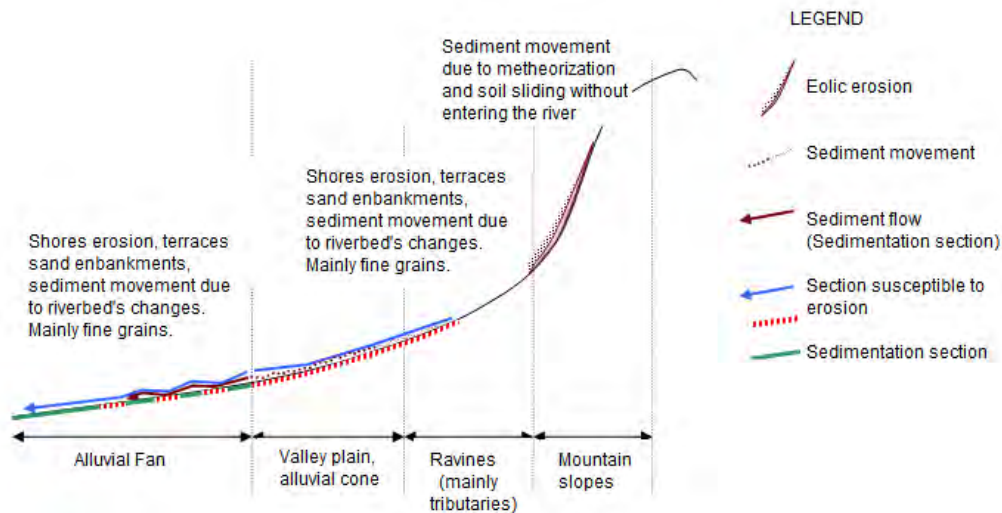

Figure 3.1.8-12 Production and entrainment of sediments in an ordinary year

ii) When torrential rains with magnitude similar to that of the El Niño happen (50 years return period)

Pursuant to the interviews performed in the locality, every time El Niño phenomenon occurs the tributary sediment flow occurs. However, since the bed has enough capacity to regulate sediments, the influence on the lower watershed is reduced.

- The amount of sediments entrained varies depending on the amount of water running by the hillsides
- The sediment flow from the tributaries reaches to enter to the main river
- Since the bed has enough capacity to regulate the sediments, the influence in the watershed is reduced

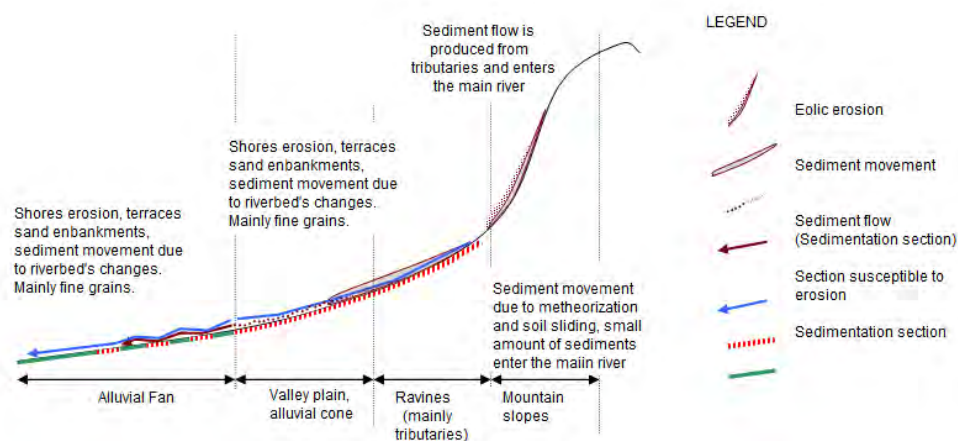

Figure 3.1.8-13 Production and entrainment of sediments during the torrential rainfall of magnitude similar to that of El Niño (1:50 year return period)

iii) Large magnitude overflows (which may cause the formation of terraces similar to those existing now), with once a few thousands year

In the coast, daily rainfall with 100 years of probability are approximately 50 mm, so land slides entrained by water scarcely occur currently. However, precisely since there are few rains, when torrential rainfall occurs, there is a high potential of water sediment entrainment.

If we suppose that rainfall occurs with extremely low possibilities, for example, 1:10.000 years, we estimate that the following situation would happen (see Figure 3.1.8-14).

Sediment entrainment from hillsides, by the amount congruent with water amount

Exceeding sediment entrainment from the bank and bottom of hillsides by the amount congruent with the water amount, provoking landslides which may close streams or beds

Destruction of the natural embankments of beds closed by the sediments, sediment flow by the destruction of sand banks

Formation of terraces and increase of sediments in the beds of lower watershed due to the large amount of sediments

- Overflowing in section between alluvial cone and critical sections, which may change the bed.

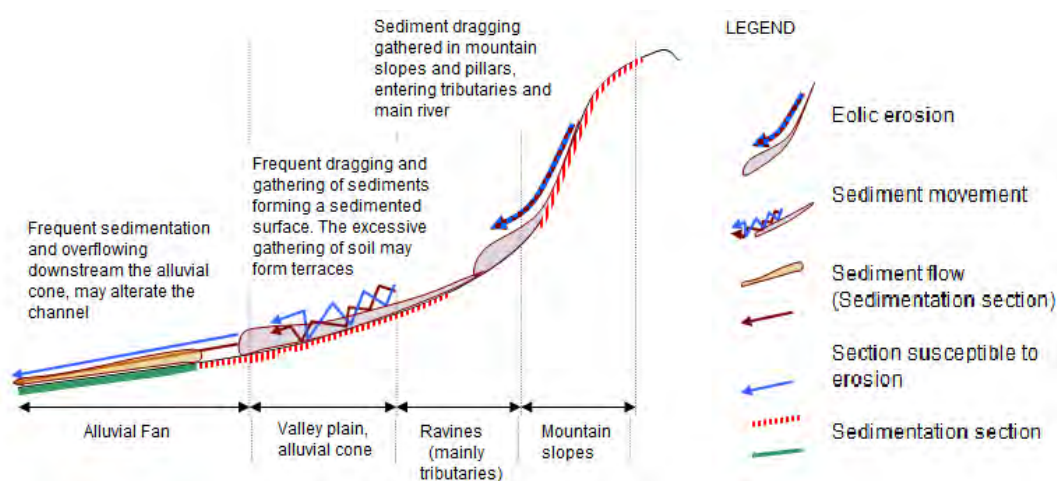

Figure 3.1.8-21 Production of sediments in large overflowing (geologic scale)

3.1.9 Run-off Analysis

The run-off study in the study area is described as follows. For further detail of Meteorology/Hydrology and Run-off study, refer to the Annex-1 Meteorology/Hydrology and Run-off Study.

3.1.9.1 Rainfall

The rainfall data is collected and processed in order to obtain the observation conditions of rainfall data in the study area, which are to be used in the run-off study. The rainfall data is collected mainly from SENAMHI which is the observation agency of the most of the stations. The observation method is not automatic but manual at regular time of a day for all of the stations in the study area so that there is no hourly data but only daily data (24 hour -rainfall data).

(1) Conditions of rainfall observation

The rainfall observation stations and their observation period in Chincha basin are as shown in the Table-3.1.9.1-1 ~ Table-3.1.9.1-2 and the Figure-3.1.9.1-1.

In Chincha basin, the rainfall has been observed in 14 stations, and the longest observation period is 31 years from 1980 to 2010.

Table-3.1.9.1-1 Rainfall observation station (Chincha river)

Code No.	Observation Station	Region	Longitude	Latitude	Responsible Agency	
203501	CONTA	Ica	75°58'	13°27'	Water Users committee	
130791	FONAGRO	Ica	76°08'	13°28'		
156114	SAN JUAN DE CASTROVIRREYNA	Huancavelica	75°38'	13°12'	SENAMHI	
156113	SAN JUAN DE YANAC	Ica	75°47'	13°13'		
151503	HUACHOS	Huancavelica	75°32'	13°14'		
110641	VILLA DE ARMAS	Huancavelica	75°22'	13°08'		
156115	SAN PEDRO DE HUACARPANA	Ica	75°39'	13°03'		
156129	LAGUNA HUICHIN	Huancavelica	75°34'	13°02'		
110633	TANTARA	Huancavelica	75°37'	13°14'		
110631	CHUNCHO	Lima	75°57'	12°45'		Water Users committee
110650	BERNALES	Ica	75°57'	13°45'		SENAMHI
110639	HUANCANO	Ica	76°37'	13°36'		
110643	TICRAPO	Huancavelica	75°26'	13°23'		
110644	TOTORA	Huancavelica	75°19'	13°08'		

Table-3.1.9.1-2 Observation period of rainfall data (Chincha river)

Observation Station	1980	1981	1982	1983	1984	1985	1986	1987	1988	1989	1990	1991	1992	1993	1994	1995	1996	1997	1998	1999	2000	2001	2002	2003	2004	2005	2006	2007	2008	2009	2010	
HUACHOS																																
VILLA DE ARMAS																																
CONTA																																
FONAGRO (CHINCHA)																																
SAN JUAN DE YANAC																																
SAN PEDRO DE HUACARPANA																																
SAN PEDRO DE HUACARPANA 2																																
TOTORA																																
TICRAPO																																
COCAS																																

: year of El niño

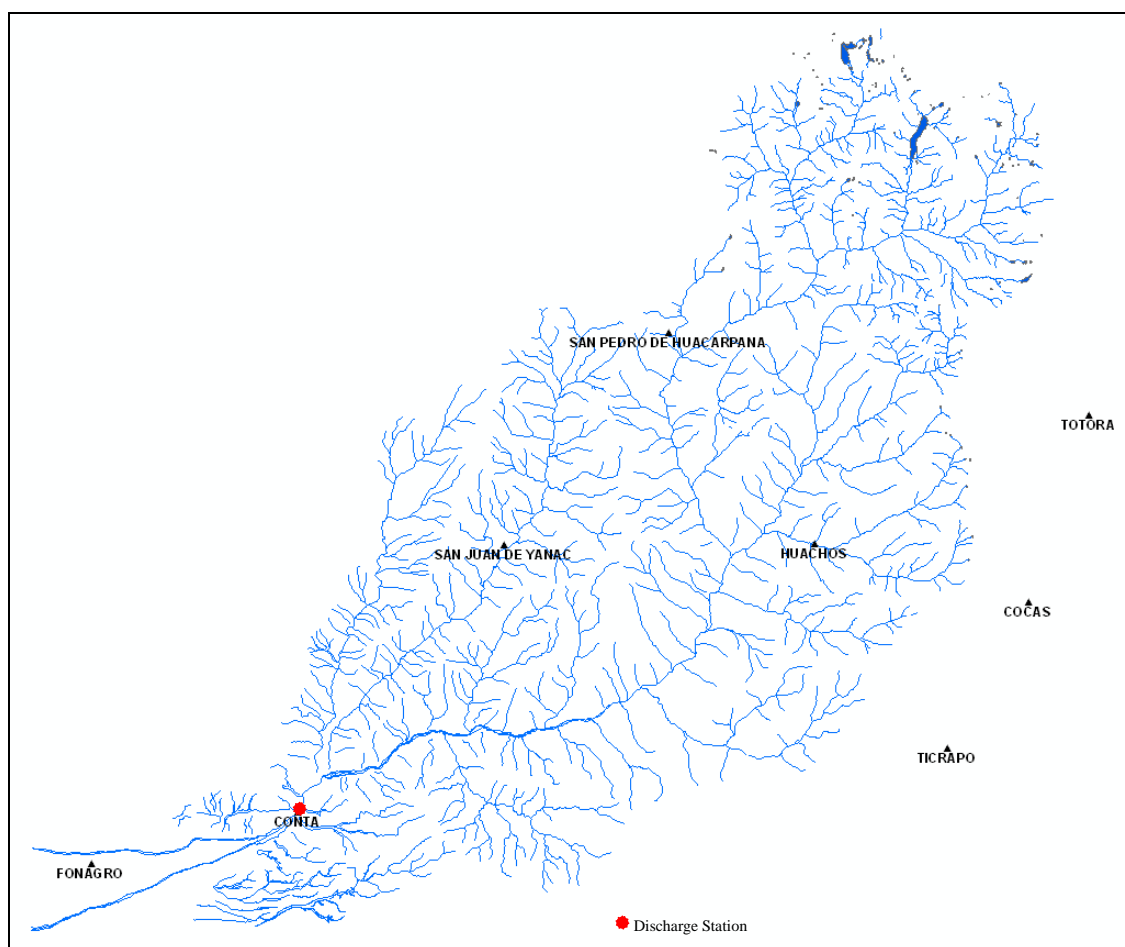

Figure-3.1.9.1-1 Location of rainfall and discharge observation station (Chincha river)

(2) Monthly rainfall

The average monthly rainfall and its distribution of each station in Chincha basin are as shown in Table-3.1.9.1-3 and the Figure-3.1.9.1-2.

According to the Table and the Figure, the monthly rainfall is large from October to April and extremely small from May to September. And the yearly rainfall varies from 6.95mm in Conta to 625.95mm in Totora .

Table - 3.1.9.1-3 Average monthly rainfall in Chincha basin and adjacent basin (mm)

Observation Station	Month												Total
	Jan.	Feb	Mar	Apr	May	June	July	Aug	Sep	Oct	Nov	Dec	
TOTORA	125.39	133.76	104.56	46.33	18.20	4.07	4.90	7.76	24.24	32.59	41.47	81.67	624.95
TICRAPO	54.24	75.45	73.35	14.10	0.44	0.20	0.03	0.45	0.98	3.99	5.05	24.32	252.60
COCAS	94.93	111.50	138.93	29.87	5.31	0.26	0.36	1.54	6.70	11.83	16.61	40.73	458.57
SAN PEDRO DE HUACARPANA 2	114.93	137.80	161.96	50.64	5.30	0.38	0.23	2.25	5.51	17.68	30.93	58.94	586.56
SAN PEDRO DE HUACARPANA	121.19	136.68	139.80	34.99	2.64	0.00	0.04	2.53	7.24	12.94	27.45	64.52	550.02

CHINCHA DE YANAC	27.03	37.28	39.98	6.97	0.27	0.00	0.10	0.02	0.76	2.81	2.11	14.08	131.41
FONAGRO (CHINCHA)	0.42	1.08	0.34	0.07	0.48	1.23	1.34	0.83	0.68	0.38	0.21	0.56	7.60
CONTA	1.84	3.24	0.81	0.31	0.01	0.03	0.06	0.04	0.05	0.18	0.14	0.24	6.95
VILLA DE ARMAS	133.69	136.26	148.26	39.55	2.82	0.00	0.01	1.57	8.52	10.84	22.17	59.92	563.61
HUACHOS	98.45	120.27	119.57	29.42	1.90	0.23	0.25	1.01	1.73	6.74	15.33	57.08	451.98

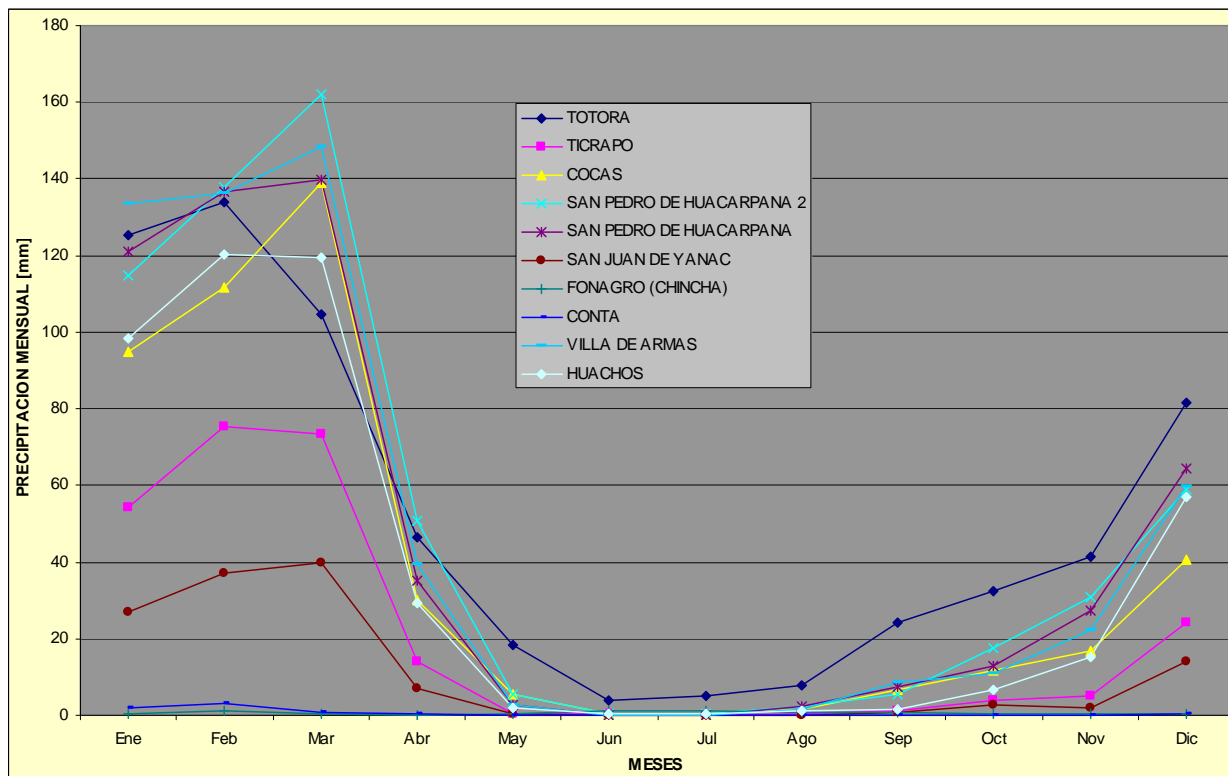

Figure-3.1.9.1-2 Distribution of average monthly rainfall in Chincha basin and adjacent basin (mm)

(3) Yearly maximum of 24-hour rainfall

The yearly maximum of 24-hour rainfall (daily rainfall) of each observation station in Chincha basin is as shown in the Table-3.1.9.1-4.

Table-3.1.9.1-4 Yearly maximum of 24-hour rainfall (daily rainfall) in Chincha basin (mm)

Year	TOTORA	TICRAPO	COCAS	SAN PEDRO DE HUACARP ANA 2	SAN PEDRO DE HUACARP ANA	SAN JUAN DE YANAC	FONAGRO (CHINCHA)	CONTA	VILLA DE ARMAS	HUACHOS
1964		21.5	19.8							
1965	24.0	20.7	21.6	15.0						
1966	15.0	12.6	20.2	5.2						
1967	24.0	24.4	36.0	31.0					59.6	
1968	20.0	10.0		16.0						
1969	22.0	35.8		24.5						
1970	23.0	40.2	22.1	24.5					24.9	
1971	21.0	28.4	29.4	20.0					31.0	
1972	27.0	32.0	30.8	26.0		12.8			29.6	
1973	25.0	44.3	36.8	21.1					42.4	
1974	22.0	14.0	20.6	14.5		8.2			36.0	
1975	19.0	19.5	22.4	22.5		10.3			35.8	
1976	20.0	25.5	21.4	17.0					38.0	
1977	25.0	24.0	20.6	15.0					36.2	
1978	20.0	5.4	14.4	26.0					61.8	
1979	25.0	18.0	27.4	32.0					27.4	
1980	35.0	24.1		19.5					43.0	33.2
1981	29.0	33.0	0.0	32.0					35.2	20.8
1982	29.0	10.9		18.0					30.0	25.8
1983	24.0	30.0							11.8	19.9
1984	37.0	20.8							11.8	29.2
1985	30.0	18.0							20.8	25.5
1986	27.0	26.8		24.0			0.3		20.0	28.5
1987	13.0						0.2		19.0	20.1
1988	25.0			32.0			0.7		20.0	33.5
1989				27.0		6.8	3.0		10.8	19.8
1990				24.0		5.5	2.0		20.0	23.2
1991				33.0					28.0	24.3
1992										
1993				23.0					26.0	
1994				30.0					21.4	26.1
1995				25.0		10.3	2.3		28.4	23.1
1996						0.4	0.9		48.6	25.4
1997					23.6	2.5	0.8		30.4	16.2
1998					25.0	11.3	1.5			38.5
1999					28.0	15.9	6.0			41.6
2000					24.2	14.0	1.5			20.5
2001					24.2	9.7	1.1			23.8
2002					30.0	14.6	1.1			37.0
2003					20.6	9.5	0.5	0.6		15.2
2004					28.7	7.2	1.2	0.4		44.2
2005					16.0	16.5	0.9	1.0		28.6
2006					27.8	37.4	3.2	6.0		25.6
2007					16.0	14.2	1.0	4.0		20.5
2008					22.6	14.7	1.9	0.8		23.8
2009					16.4	15.9	2.2	0.3		
2010						23.8				

(4) Isohyetal map of yearly average rainfall

The isohyetal map of yearly average rainfall in Chincha basin is as shown in the Figure-3.1.9.1-3.

There is big difference in the yearly rainfall data by areas in Chincha basin, for instance yearly rainfall is less than 25mm in the minimum , on the other hand 900mm in the maximum, and the amount is small in the downstream area and becomes large toward the upstream with higher elevation. In the objective section for flood protection, the yearly rainfall is almost nil, only 25mm.

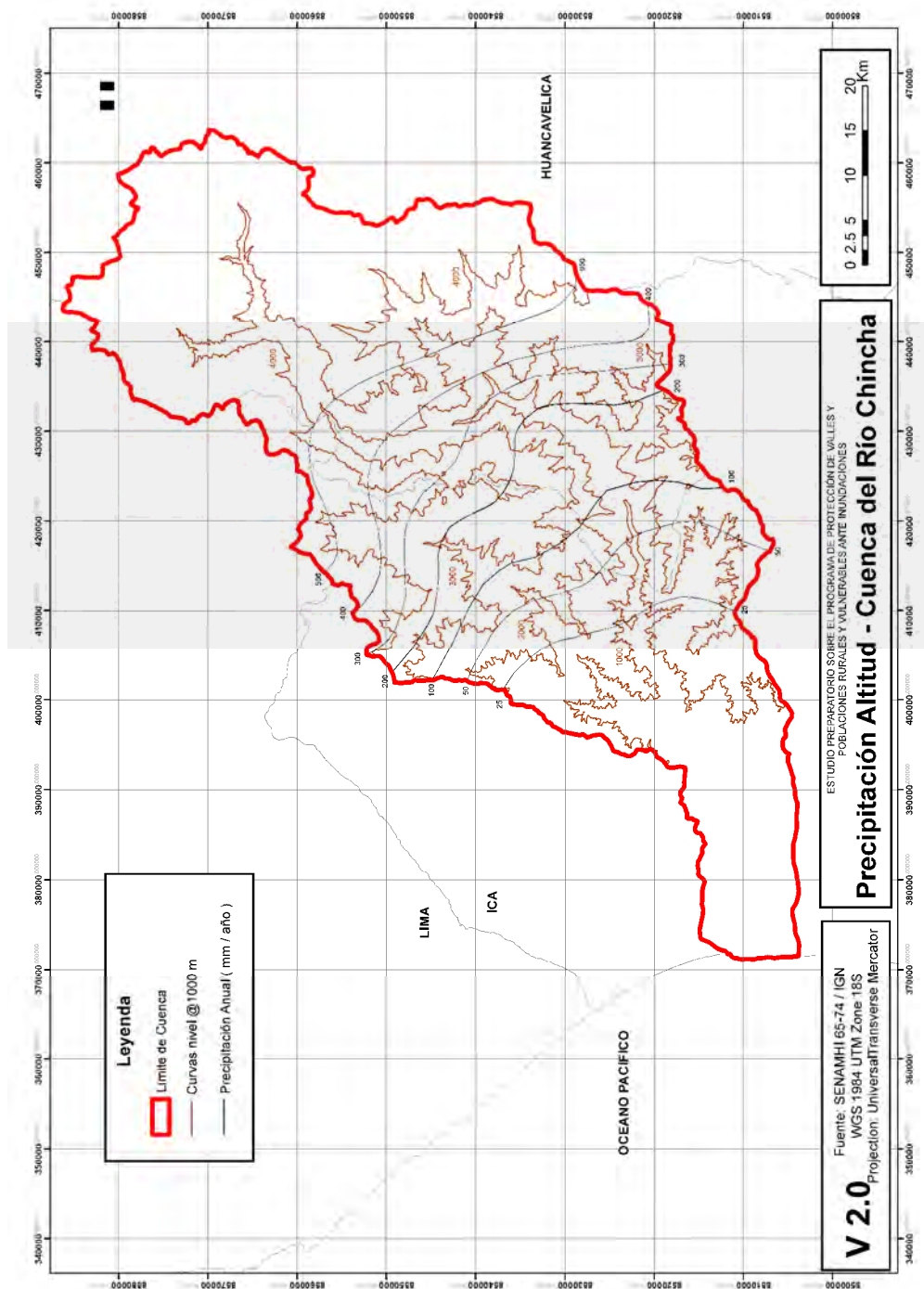

Figure-3.1.9.1-3 Isohyetal map of yearly rainfall (Chincha basin)

3.1.9.2 Discharge

The discharge observation method is not automatic but manual at regular time of a day, once a day at 7 a.m. or twice a day at 7a.m. and 7p.m. for all of the stations in the study area so that there is no hourly data but only daily data (24 hour -discharge data). Therefore instantaneous maximum discharge such as the flood peak discharge is not observed.

The water level is observed by staff gauge, and the discharge is estimated applying the water level to the relation curve between the water level and discharge which is prepared beforehand by actual measurement of flow area and velocity.

The rivers originate at high land connected with Andes Mountains and flow down through alluvial fan to the coast. The discharge observation stations are generally located at the middle stream or downstream of the alluvial fan (refer to the location map of rainfall observation stations). Since there is hardly rainfall in the coastal area, the discharge will not enter from residual area of downstream basin so that the discharge observation shows the total discharge from the whole basin. Therefore it is desirable to select the reference point for run-off analysis at such observation station.

(1) Discharge observation station

The discharge observation station in Cañete River is as shown in the Table-3.1.9.2-1. The observation is performed by SENAMHI and the water users committee.

Table-3.1.9.2-1 Discharge observation station(Chincha river)

Observation Station	Latitude	Longitude	Elevation (m.a.s.l.)
CONTA	13° 27'	75° 58'	320

(2) Yearly Maximum Daily Discharge

The yearly maximum daily discharge of each year is as shown in the Table-3.1.9.2-2.

The Chincha river diverts to Chico river and Matagente river so that the discharge of Chincha river is a total of Chico and Matagente river.

Table-3.1.9.2-2 yearly maximum daily discharge (Chincha river) (m³/s)

Year	SENAMHI	Water Users Committee			Adopted Discharge
	Total	Rio Chico	Rio Matagente	Total	
1950	155.43	-	-	-	155.43
1951	395.75	-	-	-	395.75
1952	354.00	-	-	-	354.00
1953	1,268.80	-	-	-	1,268.80
1954	664.40	-	-	-	664.40
1955	241.45	-	-	-	241.45
1956	227.83	-	-	-	227.83
1957	226.53	-	-	-	226.53
1958	88.36	35.34	53.02	88.36	88.36
1959	301.42	120.57	180.85	301.42	301.42
1960	245.17	98.07	147.10	245.17	245.17
1961	492.83	197.13	295.69	492.82	492.82
1962	395.06	158.02	237.03	395.05	395.05
1963	337.84	135.14	202.70	337.84	337.84

1964	66.95	26.78	40.17	66.95	66.95
1965	154.12	61.65	92.47	154.12	154.12
1966	139.13	55.65	83.48	139.13	139.13
1967	1,202.58	481.03	721.55	1,202.58	1,202.58
1968	43.92	17.57	26.35	43.92	43.92
1969	72.14	28.86	43.28	72.14	72.14
1970	271.57	108.63	162.94	271.57	271.57
1971	497.84	199.13	298.71	497.84	497.84
1972	784.16	313.66	470.50	784.16	784.16
1973	137.53	55.01	82.52	137.53	137.53
1974	215.66	86.26	129.40	215.66	215.66
1975	246.87	98.75	148.12	246.87	246.87
1976	311.13	124.45	186.68	311.13	311.13
1977	97.10	38.84	58.26	97.10	97.10
1978	33.00	13.20	19.80	33.00	33.00
1979	51.90	20.76	31.14	51.90	51.90
1980	33.70	13.48	20.22	33.70	33.70
1981	83.95	33.58	50.37	83.95	83.95
1982	183.60	73.44	110.16	183.60	183.60
1983	81.20	32.48	48.72	81.20	81.20
1984	292.87	117.15	175.72	292.87	292.87
1985	71.42	51.88	77.82	129.70	129.70
1986	106.26	46.00	69.00	115.00	115.00
1987	-	42.00	63.00	105.00	105.00
1988	-	28.51	42.76	71.27	71.27
1989	-	71.38	107.07	178.45	178.45
1990	24.34	9.74	14.60	24.34	24.34
1991	-	41.00	61.49	102.49	102.49
1992	-	5.95	8.92	14.87	14.87
1993	-	51.73	77.59	129.32	129.32
1994	-	75.61	113.41	189.02	189.02
1995	-	121.47	182.21	303.68	303.68
1996	-	49.85	74.77	124.62	124.62
1997	-	10.60	15.89	26.49	26.49
1998	-	112.00	168.00	280.00	280.00
1999	-	165.74	248.61	414.35	414.35
2000	-	114.93	172.39	287.32	287.32
2001	-	81.72	122.59	204.31	204.31
2002	-	47.65	71.48	119.13	119.13
2003	-	52.38	78.57	130.95	130.95
2004	-	63.73	95.60	159.33	159.33
2005	-	14.24	21.36	35.60	35.60
2006	-	62.48	93.72	156.20	156.20

3.1.9.3 Probable Flood Discharge Based on Observation Data

The reference point for run-off analysis was selected among the observation stations in each basin, and where the flood discharge with return period from 2years to 100 years are calculated based on the observation data of yearly maximum daily discharge by statistical processing. The results of calculation are as shown in the Table-3.1.9.3-1.

The following probable distribution models are used for hydrological statistic calculation, and

the most adaptable value among models is adopted for each basin, for further details refer to the Appendix attached at end of this report.

- Distribution Normal or Gaussiana
- Log - Normal 3 parameters
- Log - Normal 2 parameters
- Gamma 2 or 3 parameters
- Log - Pearson III)
- Gumbel Distribution
- Generalized Extreme Values

Table-3.1.9.3-1 Probable discharge at reference point

Riiver/Reference Point	Return Period of 2years	Return Period of 5years	Return Period of 10years	Return Period of 25 years	Return Period of 50 years	Return Period of 100 years
Chincha/ Conta	179	378	536	763	951	1,156

(m³/s)

3.1.9.4 Run-off Analysis Based on Rainfall Data (HEC-HMS Method)

There is only daily discharge data in the objective study area, and the probable discharges calculated in the previous close 3.1.9.3 show the peak discharge. In order to perform the inundation analysis described later clause, the hourly distribution of flood discharge (flood hydrograph) is required. Therefore the run-off study based on rainfall data is performed in this clause.

The run-off analysis method is to be HEC-HMS (Hydrologic Engineering Center- Hydrologic Modeling System) which is developed by US Army Corps of Engineer. This system is the run-off analysis program for general purpose which is widely used in the north America and other areas in the world, and one of the most popular program in Peru.

(1) Summary of HEC-HMS

HEC-HMS is designed to simulate the precipitation-runoff processes of dendritic watershed system. The basin model can be composed of sub-basin, reach, junction, diversion, reservoir etc. To simulate infiltration loss options for event modeling include SCS curve number, Initial Constant, Exponential, Green Ampt etc.

Several methods are included for transforming excess precipitation into surface runoff such as unit hydrograph methods including Clark, Snyder, SCS technique. Several methods including Muskingum, kinematic wave can be applied for flood routing in channel. And several methods can be applied for representing base flow contribution to sub-basin outflow.

Six different historical and synthetic precipitation methods are included. Four different methods for analyzing historical precipitation are included. The gage weights method uses an limited number of

recording and no-recording gages and Thiessen technique is one possibility for determining the weights.

The frequency storm method uses statistical data to produce balanced storms with a specific exceeding probability. The SCS hypothetical storm method implements the primary distribution for design analysis using Natural Resources Conservation Service Criteria (NRCS). Most parameters for methods included in sub-basin and reach elements can be estimated automatically using optimization trials. Six different objective functions are available to estimate goodness-of-fit between the computed results and observed discharge.

The procedure of applying HEC-HMS in this analysis is as shown below. According to this procedure the summary of run-off analysis on Majes-Camana basin is described below. As to detail of run-off study for the basin refer to Annex-1 Meteorology/Hydrology and Run-off Study, Appendix.

- (1) Preparation of Basin Model
- (2) Rainfall Analysis
 - 1) Calculation of Probable 24-hour Rainfall in Each Station
 - 2) Calculation of 24-hour Rainfall in Each Sub-basin
 - 3) Selection of Type of 24-hour Rainfall Curve
- (3) Calculation of Infiltration Loss by SSC Method
 - 1) Selection of Initial Curve Number in Each Sub-basin
 - 2) Selection of Final Curve Number in Each Sub-basin
 - 3) Verification of Model
- (4) Calculation of Probable Flood Discharges and their Flood Hydrograph

(2) Preparation of basin model

1) Division of basin

Chincha basin is divided into many sub-basins each of which has similar hydraulic characteristics, such as topography, distribution pattern of river channel, forestation conditions, surface soil conditions etc. The division of the basin is as shown in the Figure -3.1.9.4-1.

2) Preparation of basin model

The sub-basin, reach and junction are represented schematically as shown in the Figure-3.1.9.4-2 in HEC-HMS.

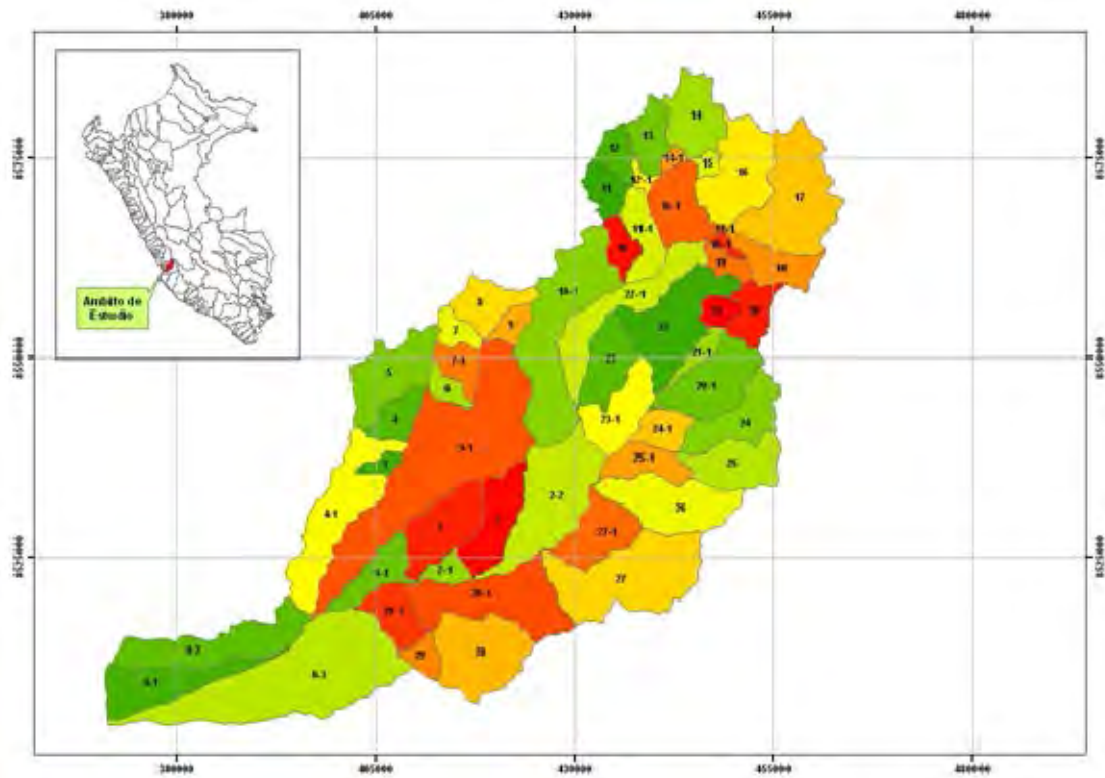

Figure-3.1.9.4-1 Division of Chincha basin



Figure-3.1.9.4-2 Schematic diagrams in HEC-HMS

(3) Rainfall analysis

Information was collected on hourly rainfall of Chivay station located in the middle basin for the period February 2011 to February 2012. Using this information, a Depth-Duration Analysis was performed for 3 different periods of flood. Of the 3 cases of floods, the longest storm duration was measured in the period of February 2012 ($Q_p = 1.400 \text{ m}^3/\text{sec.}$) and the duration was 17 hours. Thus in the discharge analysis the used storm duration was 24 hours. Furthermore, according to interviews with representatives of SENAMHI and Peruvian universities, on the Peruvian coast storm duration range is from 6 to 12 hours and for calculations for discharge analysis the usually used storm duration is 24 hours.

1) Probable 24-hour daily rainfall

The probable 24-hour rainfall in each observation station is calculated by statistical processing of yearly maximum rainfall of 24-hour as shown in the Table-3.1.9.4-1. Based on the table the isohyetal map of 24h-hour rainfall with return period of 50-year is as shown in the Figure-3.1.9.4-3.

2) 24-hour rainfall in sub-basin

24-hour rainfall in sub-basin is calculated based on 24-hour rainfall of observation stations by Inverse Distance Weighted method as shown in the Table-3.1.9.4-2. The table is for some sub-basin among many sub-basins in Chincha basin.

It is usually required to determine for each sub-basin the probabilistic rainfall using the maximum values of precipitation for each year calculated from the average precipitation. However, since the rainfall information is incomplete, it is difficult to calculate average rainfall, this is the reason why there was no choice but to use probabilistic rainfall average of each sub-basin calculated from probabilistic rainfall information from each of the rainfall stations. The results of this calculation are presented in the Table -3.1.9.4-2. Same methodology is used for other basins.

Inverse Distance Weighted method is included in HEC-HMS for calculation of average rainfall over basin, and which is calculated by the following equation using the observation data surrounding the objective sub-basin (refer to HEC-HMS, Technical Reference Manual, p-23)..

$$w_c = (1/d_c^2) / ((1/d_a^2) + (1/d_b^2) + (1/d_c^2))$$

$$P = w_a P_a + w_b P_b + w_c P_c$$

where; w_c : weight of station c, d: distance from the center of sub-basin to each station P : average rainfall in sub-basin, $P_{a,b,c}$: rainfall in each station

3) Selection of type of 24-hour rainfall curve

There is no hourly rainfall observation data but 24-hour rainfall observation data (daily rainfall data) so that the hourly data cannot but being estimated by 24-hour rainfall data.

SCS (Soil Conservation Service) hypothetical storm which is generally used in HEC-HMS is used for 24-hour rainfall curve.

This method is developed through the analysis of rainfall data in USA, which is expressed 4 types of rainfall curve with non-dimension as shown in the Table-3.1.9.4-3 and the Figure-3.1.9.4-4. The

distribution of rainfall is as shown in the Figure-3.1.9.4-5 assuming time interval. And the applied area of 4 types in USA is as shown in the Figure-3.1.9.4-6, according to which the type II is recommended to be applied to major part of USA. In addition to this it is said that 24-hour rainfall can be applicable for most of basins.

Since there is no hourly rainfall data in the study area, it is difficult to judge the type of rainfall, however the type is determined actually based on a few study examples in Peru. Miplo Mining Company analyzed the hourly rainfall data which was obtained from Chavin station installed western slope of Peru (between Cañete basin and highland of Chincha basin), and judged the rainfall type of this area belongs to type II and that the type II can be applied the central and south of coastal area. Based on the study results, type II is applied for Chincha basin.

Table-3.1.9.4-1 Probable 24-hour rainfall in each station (Chincha basin)

Station	Return period (year)						
	PT_2	PT_5	PT_10	PT_25	PT_50	PT_100	PT_200
COCAS	22.0	30.0	34.0	38.0	40.0	42.0	43.0
CONTA	1.0	2.0	4.0	6.0	9.0	13.0	18.0
FONAGRO	1.0	2.0	3.0	4.0	5.0	7.0	8.0
HUACHOS	24.0	31.0	36.0	42.0	48.0	53.0	59.0
CHINCHA DE YANAC	11.0	18.0	23.0	30.0	34.0	39.0	44.0
SAN PEDRO DE HUACARPANA	23.0	29.0	32.0	35.0	36.0	37.0	38.0
TICRAPO	20.0	31.0	37.0	45.0	50.0	55.0	60.0
TOTORA	24.0	29.0	32.0	36.0	38.0	40.0	42.0

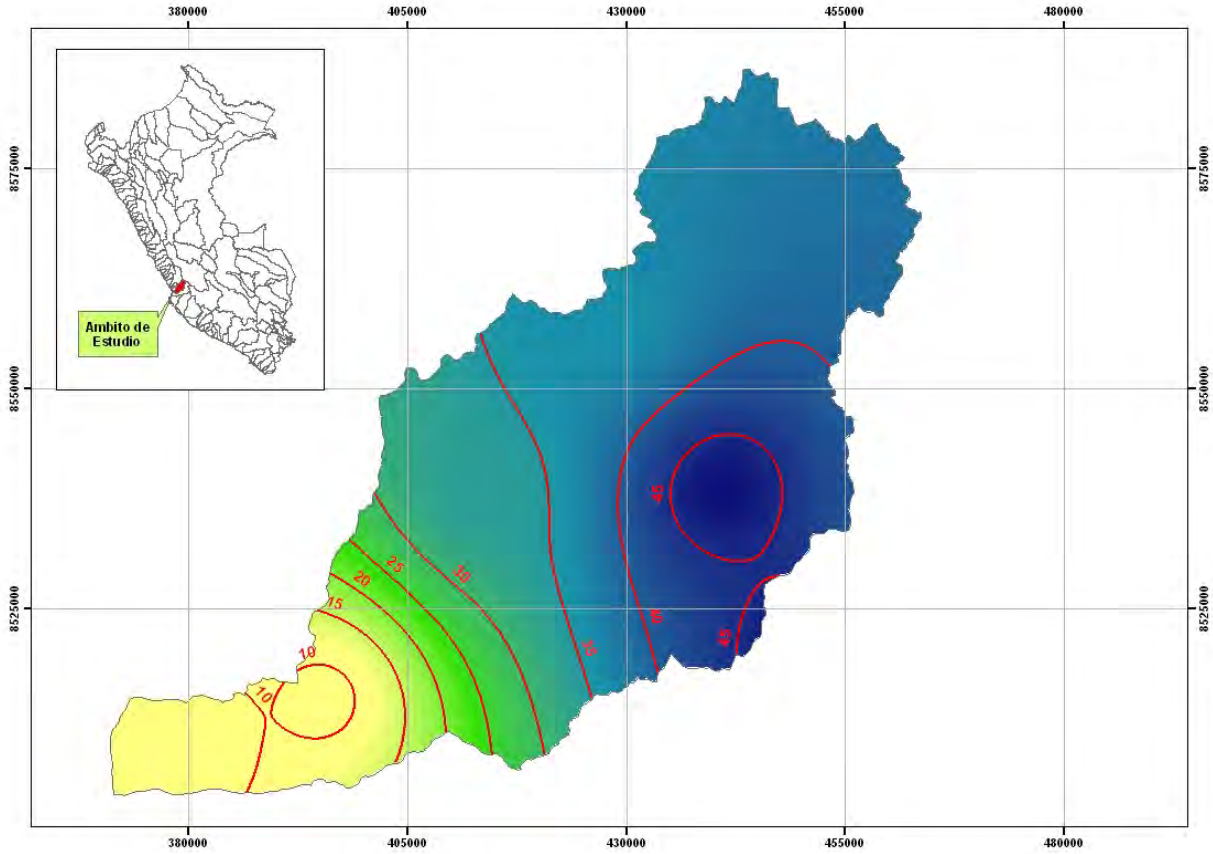

**Figure-3.1.9.4-3 Isohyetal map of 24-hour rainfall with return period of 50-year
(Chincha basin)**

Table-3.1.9.4-2 Probable 24-hour rainfall in sub-basin (Chincha basin)

Sub basin	Area [m ²]	Return period (year)				
		PT_5	PT_10	PT_25	PT_50	PT_100
0-1	72,853,800	2.6	3.9	5.1	6.5	8.8
0-2	95,339,100	2.8	4.4	6.1	8.1	11.1
0-3	241,533,000	4.4	6.4	8.6	11.2	14.7
1	73,531,600	17.8	22.1	27.8	31.5	35.9
10	22,517,800	27.9	31.3	35.1	37.1	39.0
10-1	158,721,000	27.3	30.9	34.8	36.8	38.9
11	26,871,500	27.2	30.7	34.7	36.9	39.1
1-1	39,902,900	10.8	13.9	17.7	20.9	24.8
11-1	38,959,800	27.7	31.2	35.2	37.5	39.7
12	24,616,300	26.8	30.4	34.6	37.0	39.4
12-1	6,292,700	27.1	30.7	34.9	37.3	39.7
13	35,532,500	26.7	30.4	34.7	37.2	39.8
14	61,041,700	26.7	30.4	34.8	37.5	40.2
14-1	6,477,230	27.0	30.7	35.0	37.6	40.1
15	8,361,510	27.1	30.8	35.2	37.9	40.6
16	89,357,900	27.3	31.0	35.5	38.2	40.9
16-1	61,093,700	27.4	31.1	35.4	37.9	40.5
17	129,350,000	27.7	31.4	35.9	38.6	41.3
17-1	19,473	27.7	31.4	35.9	38.6	41.3
18	41,751,000	28.2	31.8	36.3	39.0	41.6
18-1	7,304,390	27.8	31.6	36.0	38.8	41.5
19	16,081,300	28.0	31.7	36.2	39.0	41.7
2	60,158,900	20.2	24.6	30.3	34.1	38.4
20	34,374,300	28.4	32.2	36.8	39.7	42.5
20-1	78,404,600	29.2	33.6	38.7	42.8	46.4
21	16,100,800	28.3	32.2	36.8	39.9	42.8
2-1	16,088,800	17.1	21.0	25.9	29.4	33.5
21-1	16,247,300	28.7	32.9	37.9	41.6	45.0
22	102,595,000	28.3	32.2	36.8	39.9	42.8
2-2	127,871,000	24.3	28.7	34.3	38.3	42.4
22-1	86,095,700	28.0	31.5	35.5	37.6	39.8
23	53,727,200	28.1	31.9	36.4	39.3	42.1
23-1	58,386,900	28.9	33.4	38.8	43.3	47.4
24	61,672,300	29.6	33.9	39.1	43.1	46.7
24-1	30,060,500	30.6	35.5	41.3	47.0	51.8

Table-3.1.9.4-3 Accumulated curve of 24-hour rainfall in SCS hypothetical storm

Time (hr)	t/24	24 hr precipitation temporal distribution			
		Type I	Type IA	Type II	Type III
0.00	0.000	0.000	0.000	0.000	0.000
2.00	0.083	0.035	0.050	0.022	0.020
4.00	0.167	0.076	0.116	0.048	0.043
6.00	0.250	0.125	0.206	0.080	0.072
7.00	0.292	0.156	0.268	0.098	0.089
8.00	0.333	0.194	0.425	0.120	0.115
8.50	0.354	0.219	0.480	0.133	0.130
9.00	0.375	0.254	0.520	0.147	0.148
9.50	0.396	0.303	0.550	0.163	0.167
9.75	0.406	0.362	0.564	0.172	0.178
10.00	0.417	0.515	0.577	0.181	0.189
10.50	0.438	0.583	0.601	0.204	0.216
11.00	0.458	0.624	0.624	0.235	0.250
11.50	0.479	0.654	0.645	0.283	0.298
11.75	0.490	0.669	0.655	0.357	0.339
12.00	0.500	0.682	0.664	0.663	0.500
12.50	0.521	0.706	0.683	0.735	0.702
13.00	0.542	0.727	0.701	0.772	0.751
13.50	0.563	0.748	0.719	0.799	0.785
14.00	0.583	0.767	0.736	0.820	0.811
16.00	0.667	0.830	0.800	0.880	0.886
20.00	0.833	0.926	0.906	0.952	0.957
24.00	1.000	1.000	1.000	1.000	1.000

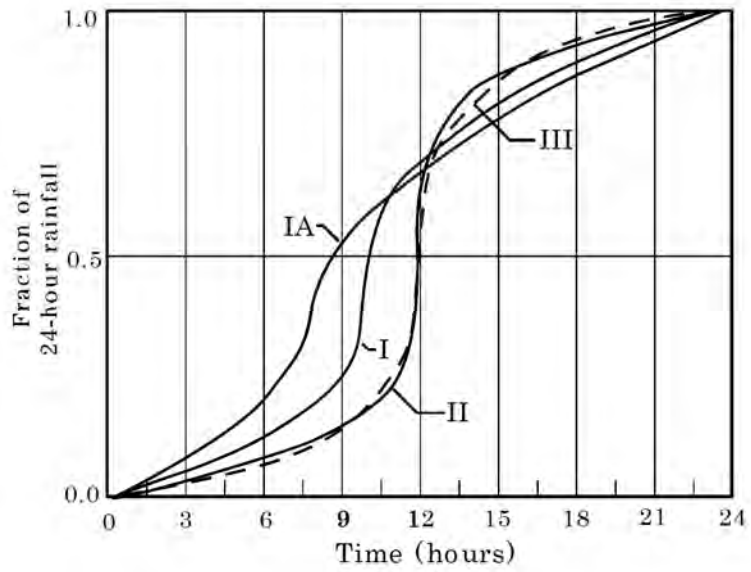

Source :Urban water hydrology for small watersheds(TR-55) Appendix B

Figure-3.1.9.4-4 Distribution of 24hour rainfall in each type

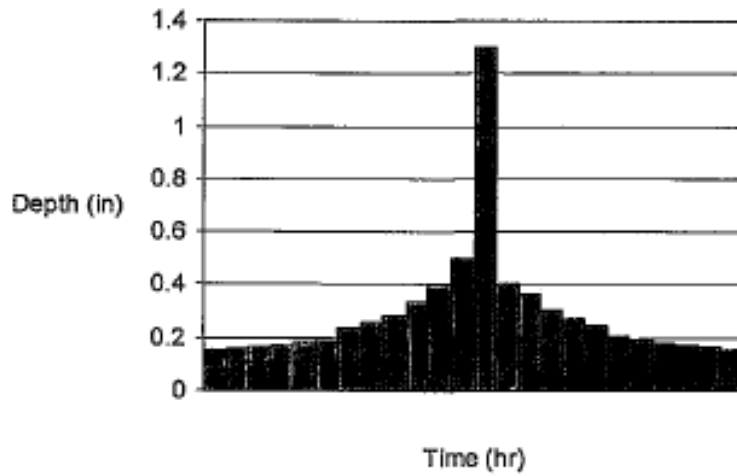
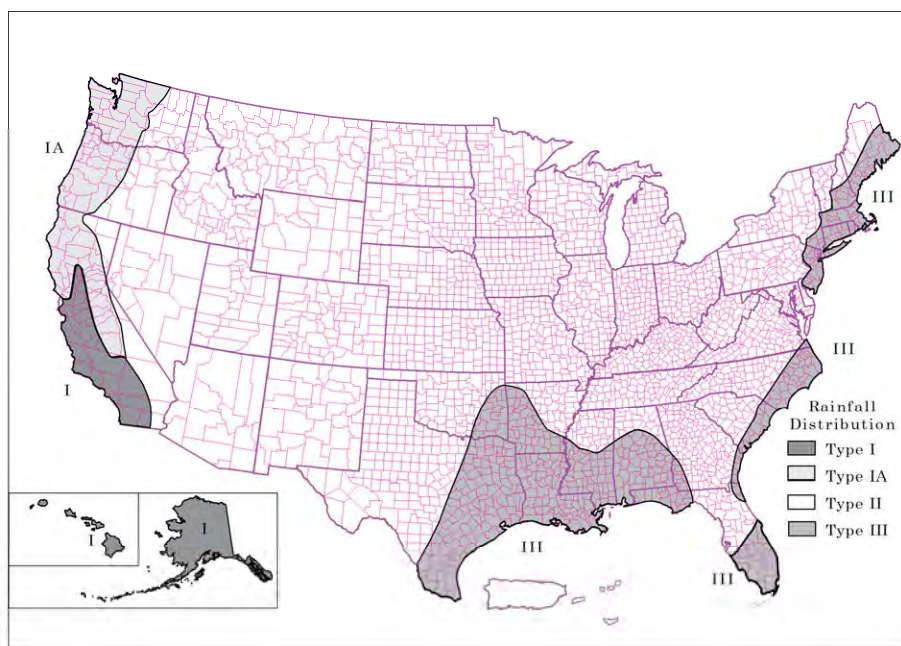

Figure-3.1.9.4-5 Division of 24-hour rainfall



Source :Urban water hydrology for small watersheds(TR-55) Appendix B

Figure-3.1.9.4-6 Type of 24-hour rainfall and applied area

(4) Excess rainfall by SSC method

1) Basic formula

SSC Curve Number (CN) Loss Model is to estimate the excess rainfall based on the function of accumulated rainfall, soil conditions, land use, initial rainfall loss etc. in the following formula.

$$P_e = \frac{(P - I_a)^2}{P - I_a + S}$$

where; P_e :Excess rainfall at time t ; P : Accumulated rainfall at time t ; I_a :Initial loss ;
 S : Possible storage volume

Assuming $I_a = 0.2 S$

$$P_e = \frac{(P_e - 0.2S)^2}{P + 0.8S}$$

Relation S and CN representing basin characteristics is as shown below.

$$S = \frac{1000}{CN} - 10$$

Assuming CN , the relation P_e and P is calculated as shown the Figure-3.1.9.4-7.

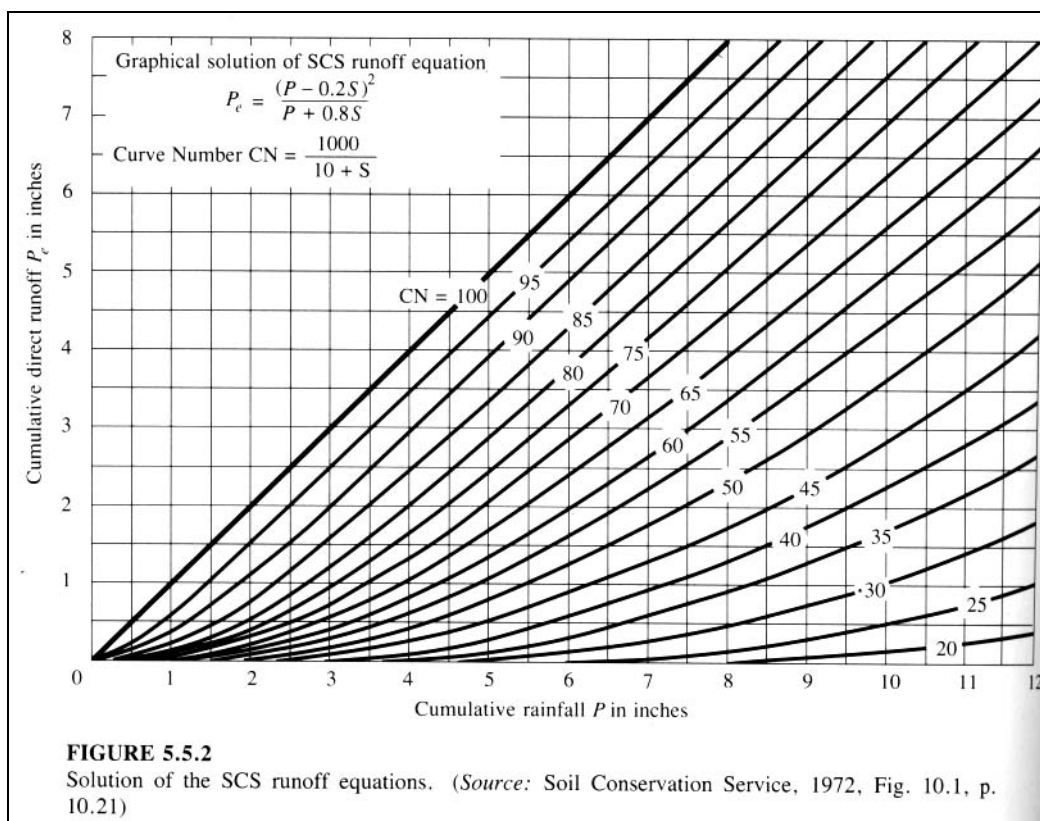

Figure-3.1.9.4-7 Relation among CN, P and P_e

2) Selection of CN in sub-basin

Referring to the Table-3.1.9.4-4 and based on the land use and soil conditions, CN of each sub-division is determined.

The initial CN value in Chincha basin is determined from 75 to 78 considering the basin characteristics and the past experiences and so on.

The run-off analysis carried out based on the initial value of CN, and the each probable flood peak and flood hydrograph are calculated for various values of CN. And examining the calculation results, the final CN value is determined as 89.

Since there is no hourly discharge data but only daily data, it is difficult to verify the study results strictly; however the verification is carried out as shown in the clause 3.1.9.5.

Table-3.1.9.4-4(1) CN value depending on land use and soil conditions (1/3)

Land Use Description		Hydrologic Soil Group			
		A	B	C	D
Cultivated land ¹ : without conservation treatment		72	81	88	91
with conservation treatment		62	71	78	81
Pasture or range land: poor condition		68	79	86	89
good condition		39	61	74	80
Meadow: good condition		30	58	71	78
Wood or forest land: thin stand, poor cover, no mulch		45	66	77	83
good cover ²		25	55	70	77
Open Spaces, lawns, parks, golf courses, cemeteries, etc.					
good condition: grass cover on 75% or more of the area		39	61	74	80
fair condition: grass cover on 50% to 75% of the area		49	69	79	84
Commercial and business areas (85% impervious)		89	92	94	95
Industrial districts (72% impervious)		81	88	91	93
Residential ³ :					
Average lot size	Average % impervious ⁴				
1/8 acre or less	65	77	85	90	92
1/4 acre	38	61	75	83	87
1/3 acre	30	57	72	81	86
1/2 acre	25	54	70	80	85
1 acre	20	51	68	79	84
Paved parking lots, roofs, driveways, etc. ⁵		98	98	98	98
Streets and roads:					
paved with curbs and storm sewers ⁵		98	98	98	98
gravel		76	85	89	91
dirt		72	82	87	89

¹For a more detailed description of agricultural land use curve numbers, refer to Soil Conservation Service, 1972, Chap. 9

²Good cover is protected from grazing and litter and brush cover soil.

³Curve numbers are computed assuming the runoff from the house and driveway is directed towards the street with a minimum of roof water directed to lawns where additional infiltration could occur.

⁴The remaining pervious areas (lawn) are considered to be in good pasture condition for these curve numbers.

⁵In some warmer climates of the country a curve number of 95 may be used.

Table3.1.9.4-4(2) CN value depending on land use and soil conditions (2/3)

TABLE 5.5.1 SCS Runoff Curve Numbers (Continued)					
<i>c. Other agricultural areas</i>					
Cover description		Curve numbers for hydrologic soil group			
Cover type	Hydrologic condition	A	B	C	D
Pasture, grassland, or range—continuous forage for grazing*	Poor	68	79	86	89
	Fair	49	69	79	84
	Good	39	61	74	80
Meadow—continuous grass, protected from grazing and generally mowed for hay	—	30	58	71	78
Brush—brush-weed-grass mixture with brush the major element†	Poor	48	67	77	83
	Fair	35	56	70	77
	Good	30	48	65	73
Woods-grass combination (orchard or tree farm)‡	Poor	57	73	82	86
	Fair	43	65	76	82
	Good	32	58	72	79
Woods§	Poor	45	66	77	83
	Fair	36	60	73	79
	Good	30	55	70	77
Farmsteads—buildings, lanes, driveways, and surrounding lots	—	59	74	82	86
<p>* Poor: < 50% ground cover or heavily grazed with no mulch. Fair: 50 to 75% ground cover and not heavily grazed. Good: > 75% ground cover and lightly or only occasionally grazed. † Poor: < 50% ground cover. Fair: 50 to 75% ground cover. Good: > 75% ground cover. ‡ CNs shown were computed for areas with 50% woods and 50% grass (pasture) cover. Other combinations of conditions may be computed from the CNs for woods and pasture. § Poor: Forest litter, small trees, and brush are destroyed by heavy grazing or regular burning. Fair: Woods are grazed but not burned, and some forest litter covers the soil. Good: Woods are protected from grazing, and litter and brush adequately cover the soil. Source: Ref. 105.</p>					
<i>d. Arid and semiarid range areas</i>					
Cover description		Curve numbers for hydrologic soil group			
Cover type	Hydrologic condition*	A†	B	C	D
Herbaceous—mixture of grass, weeds, and low-growing brush, with brush the minor element	Poor	80	87	93	
	Fair	71	81	89	
	Good	62	74	85	
Oak-aspen—mountain brush mixture of oak brush, aspen, mountain mahogany, bitter brush, maple, and other brush	Poor	66	74	79	
	Fair	48	57	63	
	Good	30	41	48	
Piñon-juniper—piñon, juniper, or both: grass understory	Poor	75	85	89	
	Fair	58	73	80	
	Good	41	61	71	
Sagebrush with grass understory	Poor	67	80	85	
	Fair	51	63	70	
	Good	35	47	55	

Table-3.1.9.4-4(3) CN value depending on land use and soil conditions (3/3)

TABLE 5.5.1 SCS Runoff Curve Numbers (Continued)					
d. Arid and semiarid range areas					
Cover description		Curve numbers for hydrologic soil group			
Cover type	Hydrologic condition*	A†	B	C	D
Desert shrub—major plants include saltbush, greasewood, creosotebush, blackbrush, bursage, palo verde, mesquite, and cactus	Poor	63	77	85	88
	Fair	55	72	81	86
	Good	49	68	79	84

* *Poor*: <30% ground cover (litter, grass, and brush overstory).
Fair: 30 to 70% ground cover.
Good: >70% ground cover.
† Curve numbers for group A have been developed only for desert shrub.
Source: Ref. 105.

Source: Maidment (1993).

Note: Hydrological Soil Group

Group Asoils have low runoff potential and high infiltration rates even when thoroughly wetted. They consist chiefly of deep, well to excessively drained sand or gravel and have a high rate of water transmission (greater than 0.30 in/hr).

Group Bsoils have moderate infiltration rates when thoroughly wetted and consist chiefly of moderately deep to deep, moderately well to well drained soils with moderately fine to moderately coarse textures. These soils have a moderate rate of water transmission (0.15-0.30 in/hr).

Group Csoils have low infiltration rates when thoroughly wetted and consist chiefly of soils with a layer that impedes downward movement of water and soils with moderately fine to fine texture. These soils have a low rate of water transmission (0.05-0.15 in/hr).

Group Dsoils have high runoff potential. They have very low infiltration rates when thoroughly wetted and consist chiefly of clay soils with a high swelling potential, soils with a permanent high water table, soils with a claypan or clay layer at or near the surface, and shallow soils over nearly impervious material. These soils have a very low rate of water transmission (0-0.05 in/hr).

(5) Probable flood discharge and hydrograph

The probable flood discharge and hydrograph are calculated by HEC-HM. The beginning of rainfall and flood hydrograph is assumed to be same hour. The kinematic wave method is applied for the flood routing of river channel.

The calculation results are as shown in the Table-3.1.9.4-5~3.1.9.4-7 and the Figure-3.1.9.4-8, and which are to be used for discharge capacity analysis of river channel, inundation analysis and flood protection planning.

Table-3.1.9.4-5 Probable flood discharge

River/Reference Point	(m ³ /s)					
	ReturnPeriod of 2-year	ReturnPeriod of 5-year	ReturnPeriod of 10-year	ReturnPeriod of 25-year	ReturnPeriod of 50-year	ReturnPeriod of 100-year
Chincha/Conta	203	472	580	807	917	1,171

Table-3.1.9.4-6 Probable specific flood discharge

River/Reference Point	(m ³ /s/km ²)						BasinArea Km2
	ReturnPeriod of 2-year	ReturnPeriod of 5-year	ReturnPeriod of 10-year	ReturnPeriod of 25-year	ReturnPeriod of 50-year	ReturnPeriod of 2-year	
Chincha/Conta	0.068	0.158	0.195	0.271	0.308	0.393	2,981

* Basin area is up stream area of reference point

* Chira basin includes territory of Ecuador

Table-3.1.9.4-7 Past maximum discharge and discharge with 50-year probability

Basin/Base point	Past Maximum Discharge	Measurement Period (year)	(m ³ /sec)
			Calculated Peak Discharge (t=1/50)
Chincha Conta	1,203	57	917

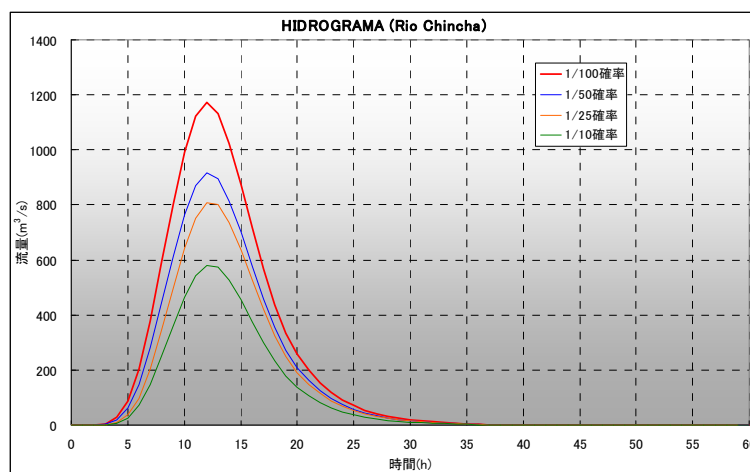

Figure-3.1.9.4-8 Flood hydrograph in chincha basin

3.1.9.5 Consideration on Results of Analysis

In Figure-3.1.9.5-1 to 3.1.9.5-4 is plotted the specific probabilistic return flow and the results of discharges analyzes conducted for each river in coastal area of Peru. (Source: "Estudio Hidrológico - Meteorológico en la Vertiente del Pacífico del Perú con Fines de Evaluación y Pronóstico del Fenómeno El Niño para Prevención y Mitigación de Desastres", Ministerio de Economía y Finanzas, Asociación BCEOM - Sofi Consult S.A. ORSTOM, Nov. 1999.)

Comparing the Creager envelopes curves and the calculated specific flows for each of the basins we can conclude that calculated probabilistic discharges are within the acceptable range.

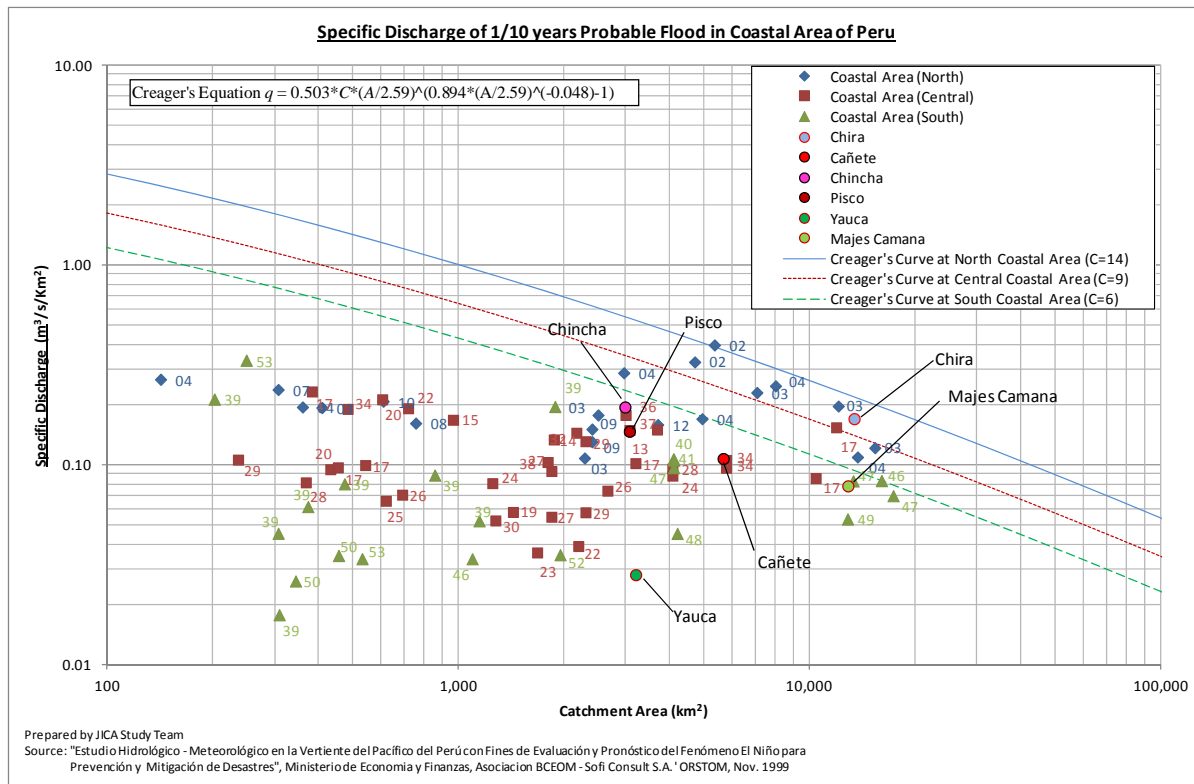

Figure 3.1.9.5-1 Probabilistic specific discharges and calculated peak discharges (t=1/10)

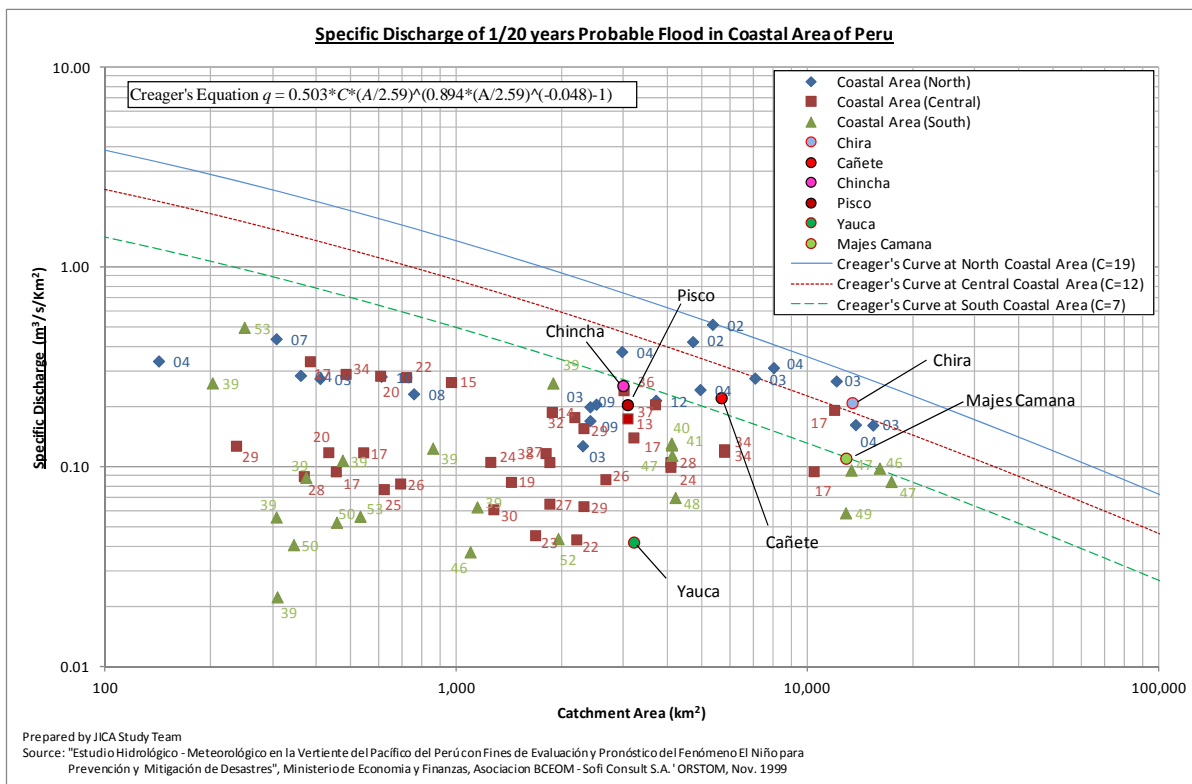

Figure 3.1.9.5-2 Probabilistic specific discharges and calculated peak discharges (t=1/20)

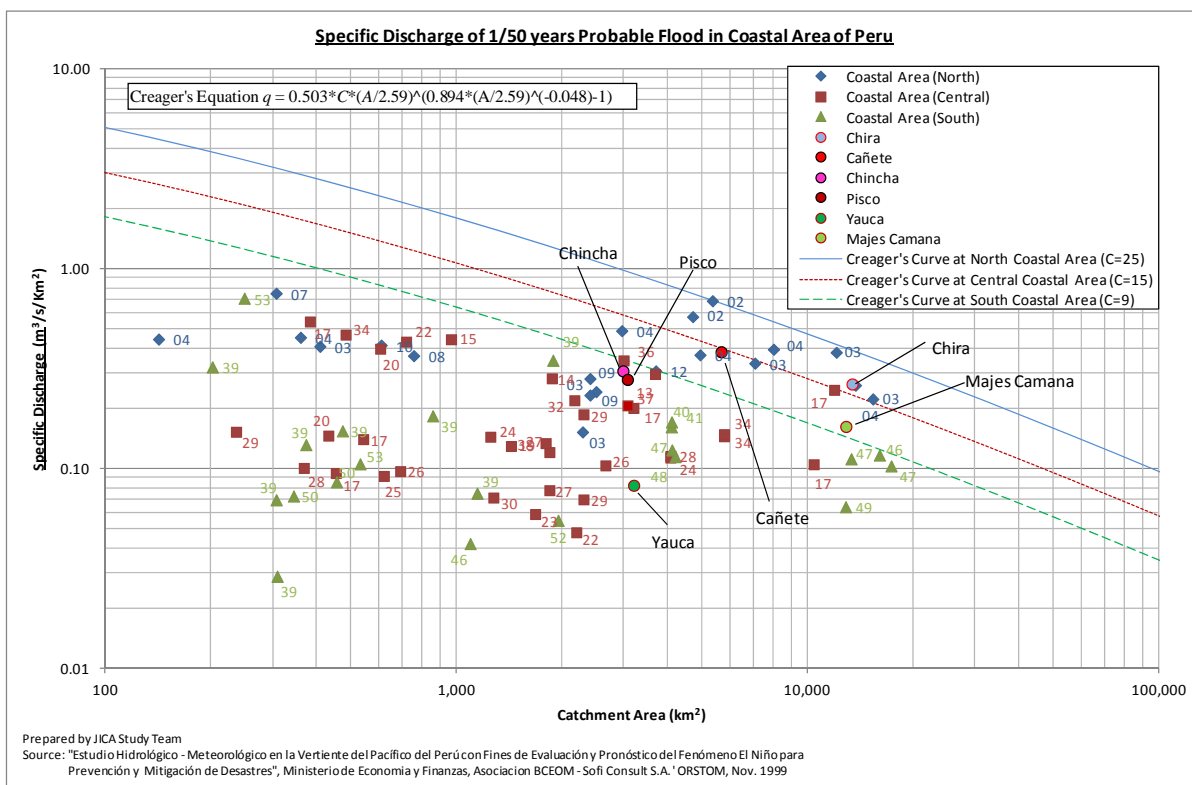

Figure 3.1.9.5-3 Probabilistic specific discharges and calculated peak discharges (t=1/50)

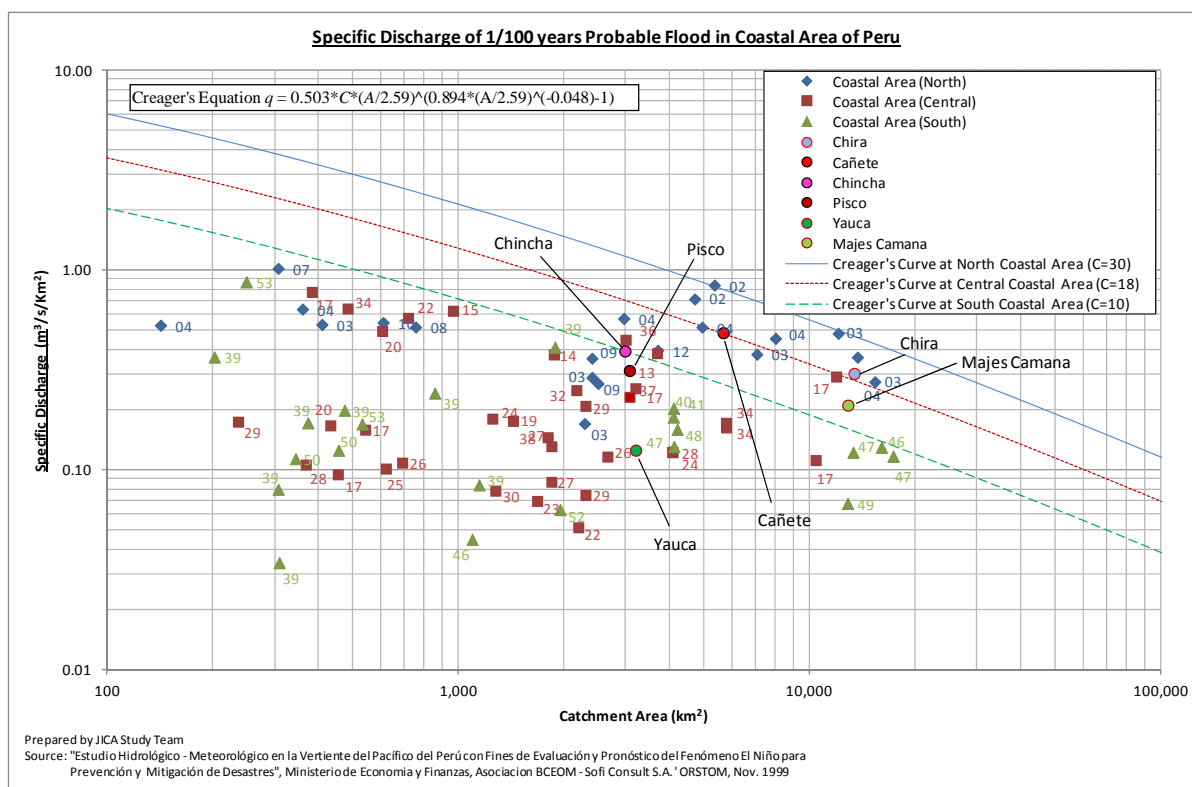

Figure 3.1.9.5-4 Probabilistic specific discharges and calculated peak discharges (t=1/100)

3.1.10 Analysis of Inundation

(1) River surveys

Prior to the flood analysis, the transversal survey or Chincha river was performed as well as the longitudinal survey of dikes. Table 3.1.10-1 shows the results of the surveys in the five rivers subject of this Study.

In order to obtain the topographic data for the analysis of the flooding zones, the results of the true measurement results indicated in Table 3.1.10-1 were used as a complement, using the satellite figures data.

Table 3.1.10-1 Basic data of the river surveys

Survey	Unit	Quantity	Notes
1. Control points survey			
Chincha river	No.	6	
2. Dikes transversal survey			250m Interval, only one margin
Chincha river	km	50	2 rivers x 25 km
3. River transversal			500m Interval

survey			
Cañete river	km	38.0	95 lines x 0.4km
4. Benchmarks			
Type A	No.	6	Every control point
Type B	No.	50	25km x one point/km

(2) Inundation analysis methods

Since the DGIH carried out the inundation analysis of the profile study at a program level using the HEC-RAS model, for this Study, we decided to use this method, and review and modify it, if necessary.

1) Analysis basis

Normally, for the inundation analysis the following three methods are used.

- ① Varied flow one-dimensional model
- ② Tank model
- ③ Varied flow horizontal two dimensional model

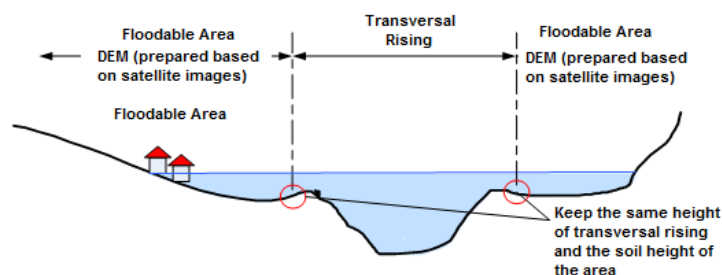

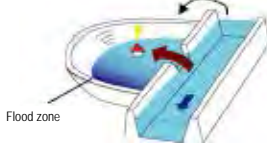
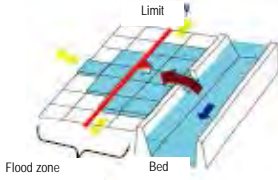

Figure 3.1.10-1 Idea of one dimensional model

The time and cost required by each method vary considerably, so only the most efficient method will be chosen, which guarantees the necessary accurateness degree for the preparation of the floodable zone maps.

Table 3.1.10-2 shows the characteristics of each analysis method. From the results of the simulation performed by DGIH, it is known that the rivers have a slope between 1/100 and 1/300, so initially the varied flow one-dimensional model was chosen assuming that the floods were serious. However, we considered the possibility that the overflowed water extends within the watershed in the lower watershed, so for this study the variable regimen horizontal bi-dimensional model was used to obtain more accurate results

Table 3.1.10-2 Methodology of inundation analysis

Analysis methods	Vary flow unidimensional model	Tank model	Varied flow bi-dimensional horizontal model
Basic concept of the flood zone definition	In this method, the flood zone is considered to be included in the river bed, and the flood zone is determined by calculating the water level of the bed in relation to the maximum flooding flow	This method manages the flood zone and bed separately, and considers the flooding zone as a closed body. This closed water body is called <i>pond</i> where the water level is uniform. The flood zone is determined in relation to the relationship between the overflowed water from the river and entered to the flood zone, and the topographic characteristics of such zone (water level– capacity– surface).	This method manages the flood zones and the bed separately, and the flood zone is determined by analyzing the bidimensional flow of the behaviour of water entered to the flood zone.
Approach			
Characteristics	It is applicable to the floods where the overflowed water runs by the flood zone by gravity; that means, current type floods. This method must manage the analysis area as a protected area (without dikes).	Applicable to blocked type floods where the overflowed water does not extend due to the presence of mountains, hills, embankments, etc. The water level within this closed body is uniform, without flow slope or speed. In case there are several embankments within the same flood zone, it may be necessary to apply the pond model in series distinguishing the internal region.	Basically, it is applicable to any kind of flood. Beside the flood maximum area and the water level, this method allows reproducing the flow speed and its temporary variation. It is considered as an accurate method compared with other methods, and as such, it is frequently applied in the preparation of flood irrigation maps. However, due to its nature, the analysis precision is subject to the size of the analysis model grids.

2) Inundation analysis method

Figure 3.1.10-2 shows the conceptual scheme of the variable regimen horizontal bi-dimensional model.

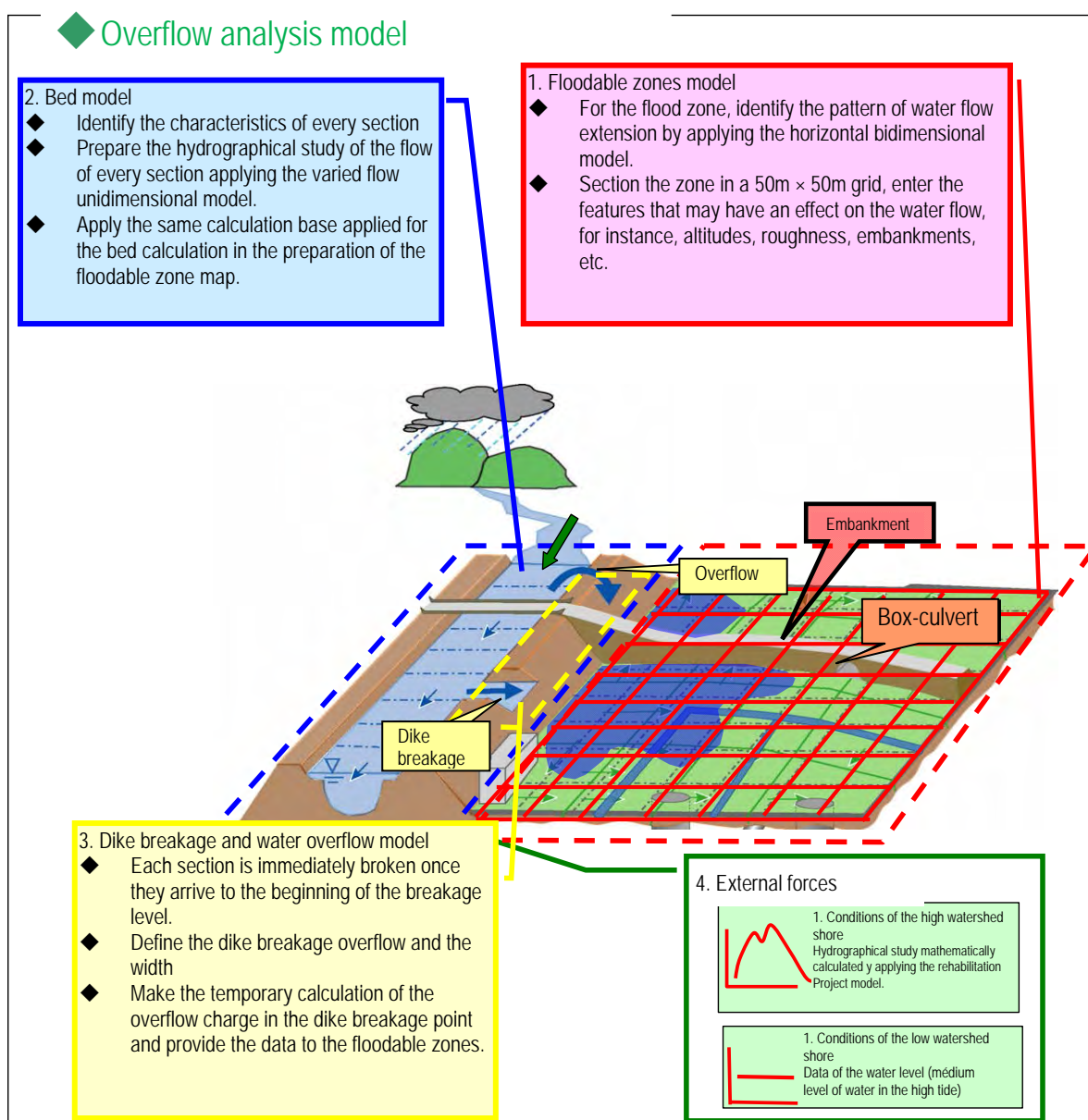

Figure 3.1.10-2 Conceptual scheme of the inundation analysis model

(3) Discharge capacity analysis

The current discharge capacity of the river channel was estimated based on the results of the river survey and applying the HEC-RAS method, which results appear in Figure 3.1.10-3 and Figure-3.1.10-4. This Figure also shows the flooding flows of different return periods obtained by run-off analysis, which allow evaluating in what points of the Chincha river watershed flood may happen and what magnitude of flood flow may they have.

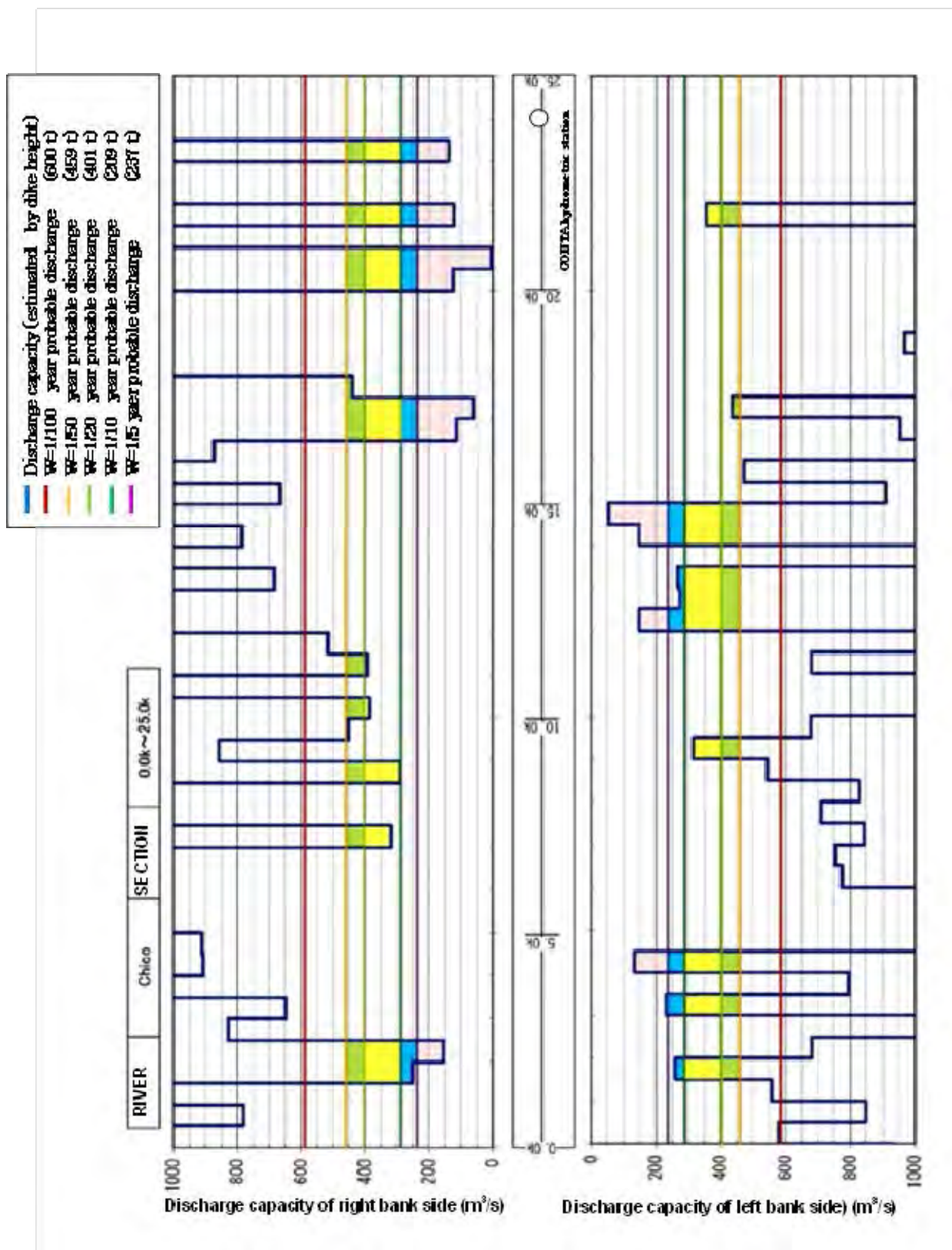

Figure 3.1.10-3 Current discharge capacity of Chico river

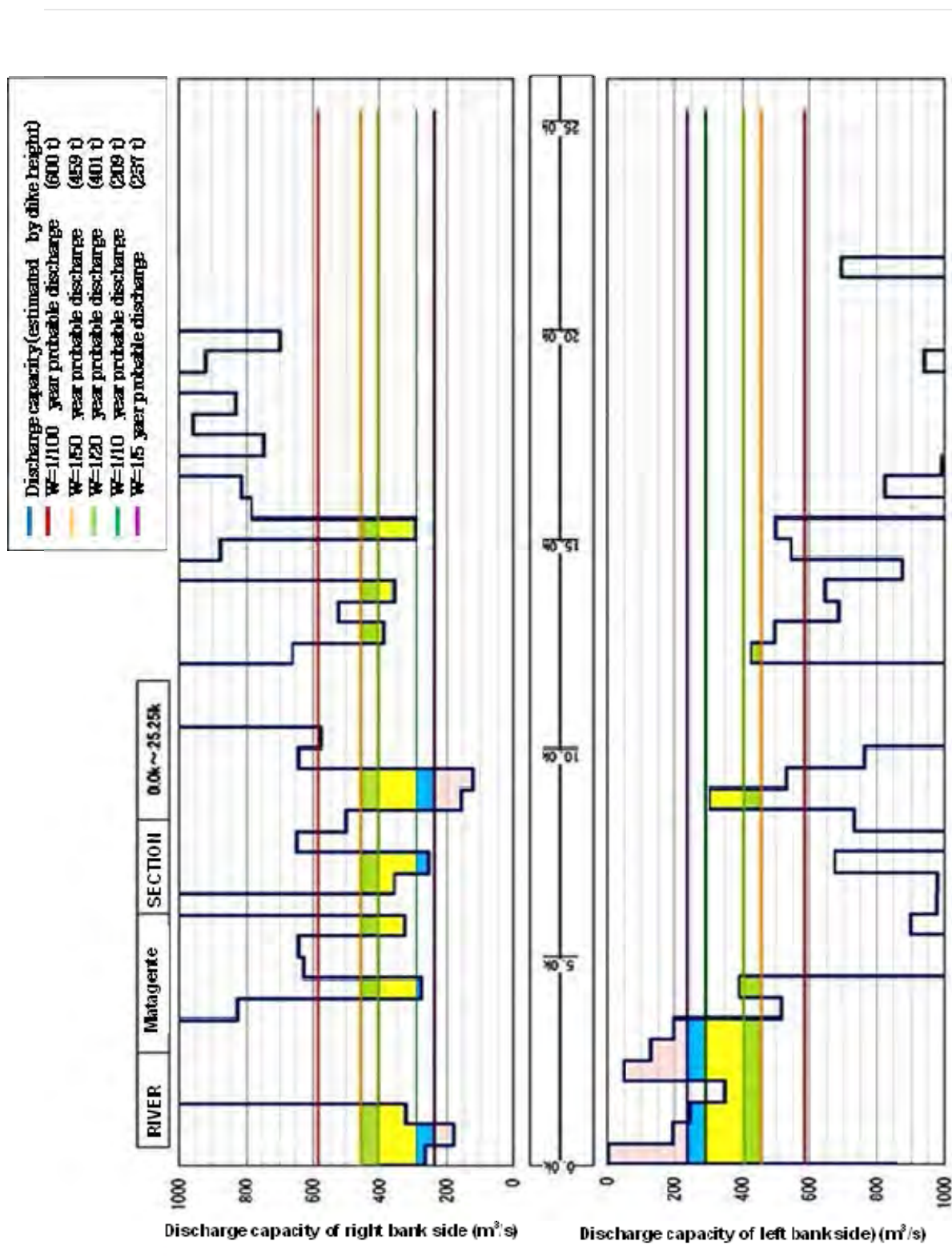

Figure 3.1.10-5 Current discharge capacity of Matagente river

(4) Inundation area

As a reference, Figures 3.1.10-5 and 3.1.10-6 show the results of the inundation area calculation in each watershed compared to the flooding flow with a 50 year return period.

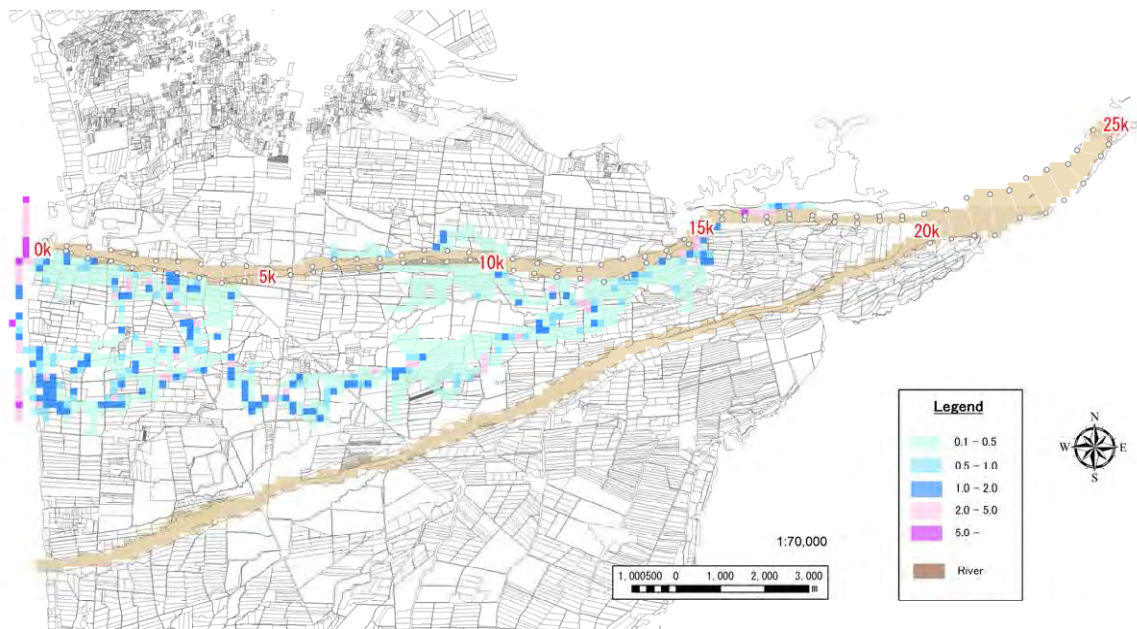

Figure 3.1.10-5 Inundation area of Chincha river – Chico (50 year period floods)

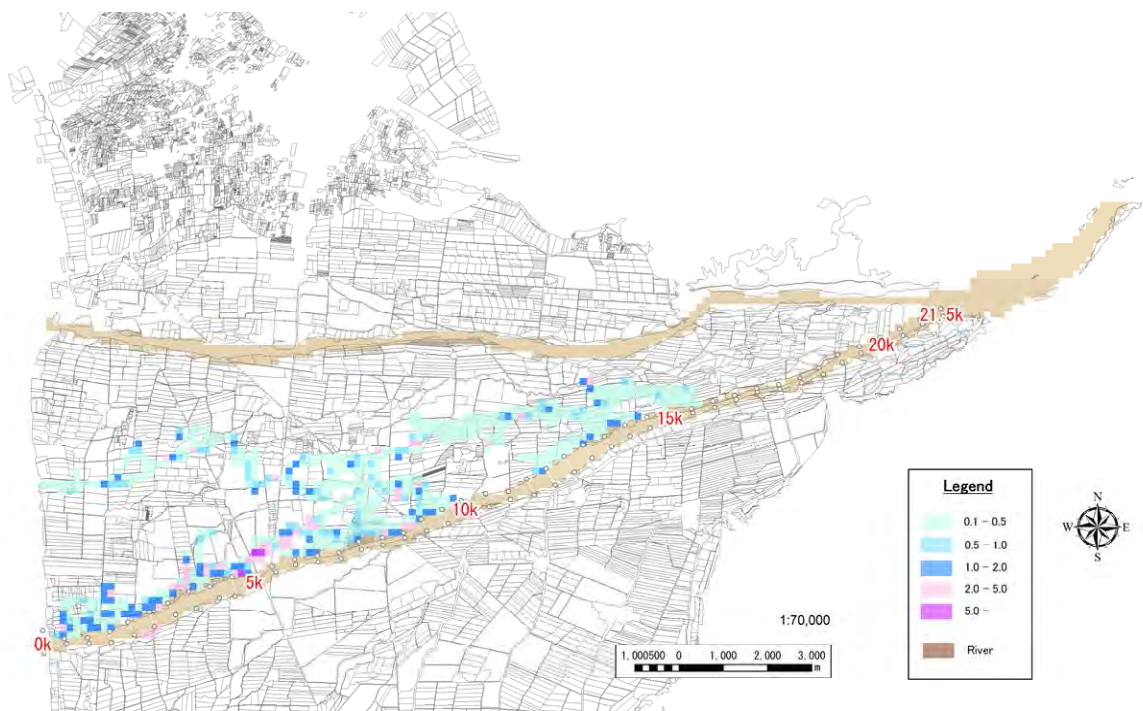

Figure 3.1.10-6 Inundation area of Chincha river – Matagente (50 year period floods)

3.2 Definition of Problem and Causes

3.2.1 Problems of Flood Control Measures in the Study Area

Based on the results of the Chincha River, the main problem on flood control was identified, as well as the structures to be protected, which results are summarized in Table 3.2.1-1.

Table 3.2.1-1 Problems and conservation measures of flood control works

Problems		Overflowing			Dike erosion	Banks erosion	Non-working intake	Non-working derivation works
		Without dikes	Sediment in bed	Lack of width				
Structures to be protected	Agricultural lands	○	○	○	○	○	○	○
	Irrigation channels					○	○	
	Urban area	○		○				○
	Roads					○		
	Bridges		○					

3.2.2 Problem Causes

Next, the main problem and its direct and indirect causes for flood control in the Study Area are described:

(1) Main problem

Valleys and local communities highly vulnerable to floods

(2) Direct and indirect causes

Table 3.2.2-2 shows the direct and indirect causes of the main problem

Table 3.2.2-2 direct and indirect causes of the main problem

Direct cause	1. Excessive flood flow	2. Overflowing	3. Insufficient maintenance of control works	4. Insufficient communitarian activities for flood control
Indirect causes	1.1 Frequent occurrence of extraordinary weather (El Niño, etc..)	2. Lack of flood control works	3.1 Lack of maintenance knowledge and skills	4.1 Lack of knowledge and flood prevention techniques
	1.2 Extraordinary rains in the middle and upper basins	2.2 Lack of resources for the construction of works	3.2 Lack of training in maintenance	4.2 Lack of training in flood prevention
	1.3 Vegetation cover almost zero in the middle and upper basins	2.3 Lack of plans for flood control in basins	3.3 Lack of dikes and banks repair	4.3 Lack of early warning system
	1.4 Excessive sediment dragging from the upper and middle river levee	2.4 Lack of dikes	3.4 Lack of repair works and referral making	4.4 Lack of monitoring and collection of hydrological data
	1.5 Reduction of hydraulic capacity of rivers by altering slopes, etc.	2.5 Lack of bed channel width	3.5 Use of illegal bed for agricultural purposes	

		2.6 Accumulation of sediments in beds	3.6 Lack of maintenance budget	
		2.7 Lack of width at the point of the bridge construction		
		2.8 Elevation of the bed at the point of the bridge construction		
		2.9 Erosion of dikes and banks		
		2.10 Lack of capacity for the design of the works		

3.2.3 Problem Effects

(1) Main problem

Valleys and local communities highly vulnerable to floods

(2) Direct and indirect effects

Table 3.2.3-1 shows the direct and indirect effects of the main problem

Table 3.2.3-1 Direct and indirect effects of the main problem

Direct Effects	1. Agriculture Damages	2. Direct damages to the community	3. Social infrastructure damages	4. Other economical damages
Indirect Effects	1.1 Agriculture and livestock damage	2.1 Private property and housing loss	3.1 Roads destruction	4.1 Traffic interruption
	1.2 Agricultural lands loss	2.2 Industries and facilities loss	3.2 Bridges loss	4.2 Flood and evacuations prevention costs
	1.3 Irrigation channels destruction	2.3 Human life loss and accidents	3.3 Running water, electricity, gas and communication infrastructures' damages	4.3 Reconstruction costs and emergency measures
	1.4 Work destruction and derivation	2.4 Commercial loss		4.4 Work loss by local inhabitants
	1.5 Dikes and banks erosion			4.5 Communities income reduction
				4.6 Life quality degradation
				4.7 Loss of economical dynamism

(3) Final effect

The main's problem final effect is the community socio-economic impediment development of the affected area.

3.2.4 Causes and Effects Diagram

Figure 3.2.4-1 shows the causes and effects diagram done based on the above analysis results.

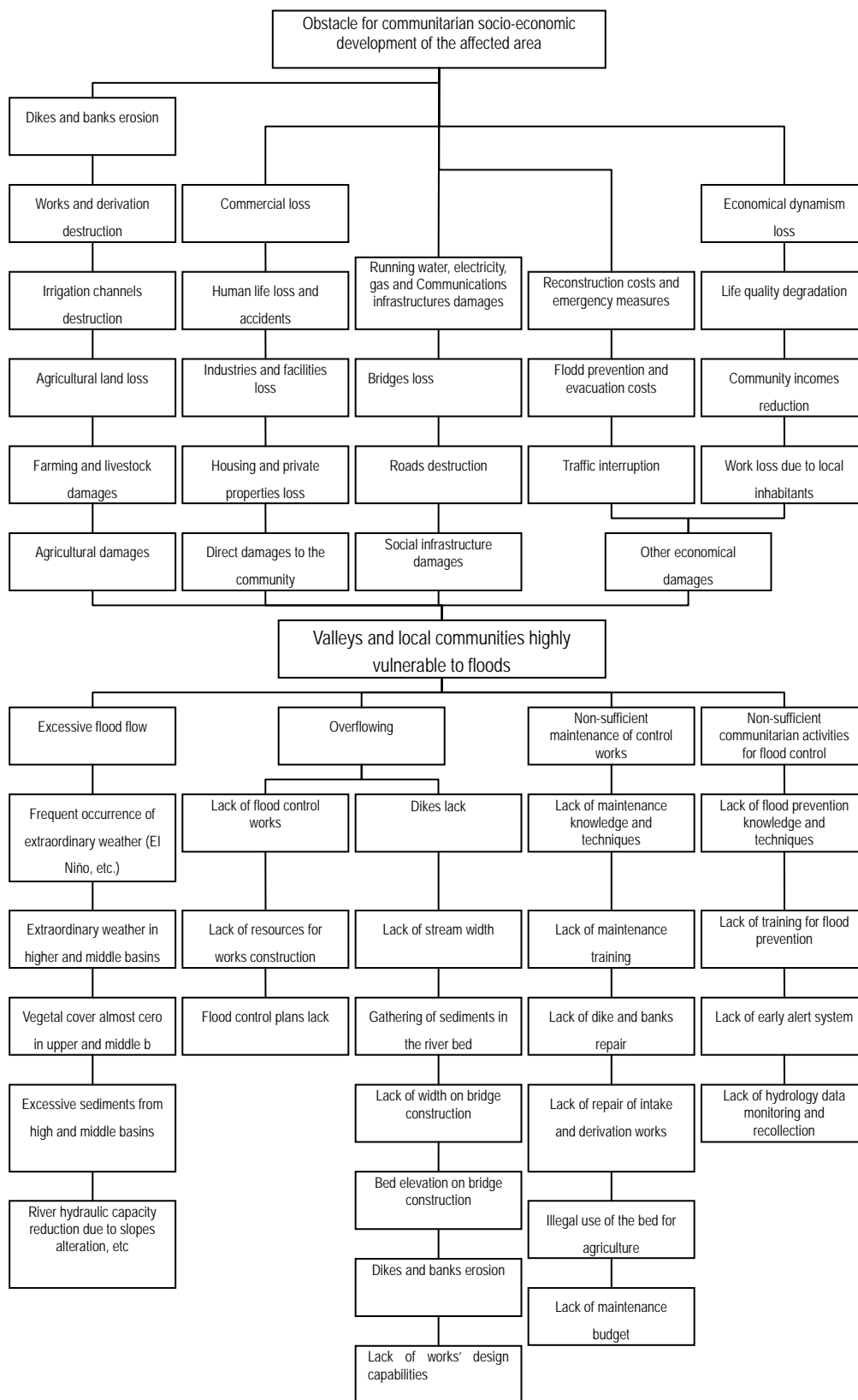

Figure 3.2.4-1 Causes and effects diagram

3.3 Objective of the Project

The final impact that the Project wants to achieve is to alleviate the vulnerability of valleys and local community to flooding and promote local economic development.

3.3.1 Solving Measures for the Main Problem

(1) Main objective

Soothe the valleys and local community to flooding vulnerability.

(2) Direct and indirect measures

In table 3.3.1-1, direct and indirect solutions measures for the problem are shown.

Table 3.3.1-1 Direct and indirect solution measures to the problem

Direct measures	1. Analyze and relieve excessive flood flow	2. Prevent overflow	3. Full compliance with maintenance of flood control works	4. Encourage community flood prevention
Indirect measures	1.1 Analyze extraordinary weather (El Niño, etc..)	2.1 Construct flood control works	3.1 Strengthen maintenance knowledge and skills	4.1 Strengthen knowledge and skills to prevent flooding
	1.2 Analyze extraordinary rainfall in the upper and middle basins	2.2 Provide resources for the works construction	3.2 Reinforce training maintenance	4.2 Running flood prevention training
	1.3 Planting vegetation on the upper and middle basins	2.3 Develop plans for flood control basins	3.3 Maintain and repair dikes and banks	4.3 Creating early warning system
	1.4 Relieve Excessive sediment entrainment from the upper and middle river dikes	2.4 Build dikes	3.4 Repair intake and derivation works	4.4 Strengthen monitoring and water data collection
	1.5 Take steps to alleviate the reduction in hydraulic capacity of rivers by altering slopes, etc.	2.5 Extends the width of the channel	3.5 Control the illegal use of bed for agricultural purposes	
		2.6 Excavation of bed	3.6 Increase the maintenance budget	
		2.7 Extending the river at the bridge's construction		
		2.8 Dredging at the point of the bridge construction		
		2.9 Control dikes and banks erosion		
		2.10 Strengthen the capacity for works design		

3.3.2 Expected Impacts for the Main's Objective Fulfillment

(1) Final impact

The final impact that the Project wants to achieve is to alleviate the vulnerability of the valleys and the local community to floods and promoting local socio-economic development.

(2) Direct and indirect impacts

In table 3.3.2-1 direct and indirect impacts expected to fulfill the main objective to achieve the final impact are shown.

Table 3.3.2-1 direct and indirect impacts

Direct Impacts	1. Agricultural damage relief	2. Relief of direct harm to the community	3. Relief of social infrastructure damage	4. Relief of other economic damage
Indirect Impacts	1.1 Relief to crops and livestock damage	2.1 Housing and private properties loss prevention	3.1 Road destruction prevention	4.1 Traffic interruption prevention
	1.2 Relief for farmland loss	2.2 Prevention of Industries and facilities establishments	3.2 Prevention of bridges loss	4.2 Reducing costs of flood prevention and evacuation
	1.3 Prevention of the destruction of irrigation channels	2.3 Prevention of accidents and human life loss	3.3 Running water, electricity, gas and communication infrastructures' relief	4.3 Cost reduction of the reconstruction and emergency measures
	1.4 Prevention of destruction works of intake and derivation	2.4 Commercial loss relief		4.4 Increase of local community hiring
	1.5 Dikes and banks erosion relief			4.5 Community income increase
				4.6 Life quality improvement
				4.7 Economic activities development

3.3.3 Measures - Objectives – Impacts Diagram

In Figure 3.3.3-1 the measures - objectives – impacts diagram is shown.

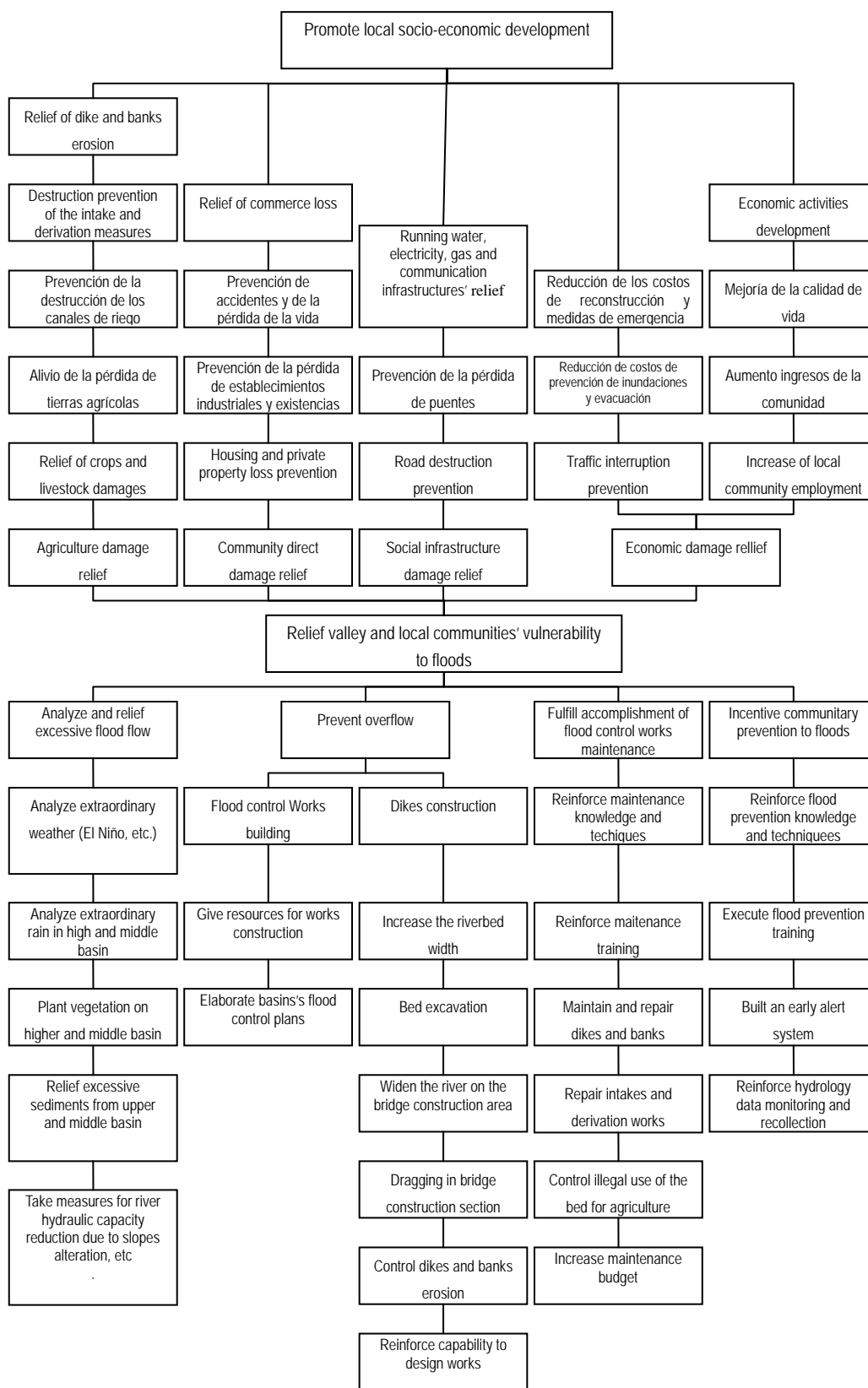

Figure 3.3.3-1 Measures - objectives – impacts diagram

4. FORMULATION AND EVALUATION

4.1 Definition of the Assessment Horizon of the Project

The Project's assessment horizon will be of 15 years, same as the one applied on the Program Profile Report. The Annex-10 of SNIP regulation stipulates that the assessment horizon should be basically 10 years; however the period can be changed in case that the project formulator (DGIH in this Project) admits the necessity of change. DGIH adopted 15 years in the Program Profile Report and OPI and DGPM approved it in March 19, 2010. In JICA's development study it should be generally 50 years, so the JICA Study Team inquired on the appropriate period to DGIH and OPI, they directed JICA Study Team to adopt 15 years. And the social evaluation in case of 50 years assessment horizon is described in Annex-14 Implementation Program of Japanese Yen Loan Project.

4.2 Supply and Demand Analysis

The theoretical water level was calculated considering flowing design flood discharge based on river cross sectional survey executed with a 500m interval, in each Watershed, considering a flood discharge with a return period of 50 years. Afterwards, the dike height was determined as the sum of the design water level plus the freeboard of dike.

This is the dike height required to prevent damages caused by design floods and represents the local community demand indicator.

The height of the existing dike or the height of the present ground is that required to prevent present flood damages, and represents the present supply indicator.

The difference between the design dike (demand) and the height of the present dike or ground represents the difference or gap between demand and supply.

Table 4.2-1 shows the averages of flood water level calculated with a return period of 50 years in "3.1.9 Run-off Analysis"; of the required dike height (demand) to control the discharge adding the design water level plus the freeboard dike; the dike height or that of the present ground (supply), and the difference between these last two (difference between demand-supply) of the river. Then, Table 4.2-2 shows the values of each point in Chincha river. The dike height or that of the present ground is greater than the required dike height, at certain points. In these, the difference between supply and demand was considered null.

Table 4.2-1 Watershed demand and supply

Basin	Present Height of Embankment or Ground(supply)		Flood Water Level of 1/50 Year Probability	Freeboard of Embankment	Required Height of Embankment (demand)	Supply and Demand Gap	
	Left Bank	Right Bank				Left Bank	Right Bank
	①	②	③	④	⑤=③+④	⑥=⑤-①	⑦=⑤-②
Chincha River							
Chico River	144.81	145.29	144.00	0.80	144.80	0.40	0.45
Matagente River	133.72	133.12	132.21	0.80	133.01	0.29	0.36

Table 4.2-2 Demand and Supply according to calculation (Chico river)

Watershed	Dike Height / current land (supply)		Theoretical water level with a return period of 50 years	Dike Freeboard	Required dike's height (demand)	Diff. demand/supply	
	Left bank	Right bank				Left bank	Right bank
	①	②				③	④
0.0	3.71	4.12	2.94	0.80	3.74	0.03	0.00
0.5	6.72	8.25	6.38	0.80	7.18	0.47	0.00
1.0	10.89	10.80	10.30	0.80	11.10	0.21	0.30
1.5	15.17	20.55	14.98	0.80	15.78	0.61	0.00
2.0	19.56	19.55	19.83	0.80	20.63	1.06	1.08
2.5	24.95	24.12	24.62	0.80	25.42	0.46	1.29
3.0	30.48	30.30	29.93	0.80	30.73	0.25	0.43
3.5	34.82	35.29	35.11	0.80	35.91	1.09	0.62
4.0	40.27	42.10	39.92	0.80	40.72	0.45	0.00
4.5	46.38	48.59	47.57	0.80	48.37	1.99	0.00
5.0	53.20	51.85	50.96	0.80	51.76	0.00	0.00
5.5	58.00	58.31	55.93	0.80	56.73	0.00	0.00
6.0	62.36	62.11	60.00	0.80	60.80	0.00	0.00
6.5	65.97	67.28	65.23	0.80	66.03	0.07	0.00
7.0	70.68	71.22	70.31	0.80	71.11	0.43	0.00
7.5	76.17	75.60	75.78	0.80	76.58	0.41	0.98
8.0	81.79	82.51	81.44	0.80	82.24	0.45	0.00
8.5	87.91	88.23	87.25	0.80	88.05	0.14	0.00
9.0	92.69	92.27	92.44	0.80	93.24	0.56	0.97
9.5	98.27	99.23	98.58	0.80	99.38	1.10	0.14
10.0	104.25	103.92	103.88	0.80	104.68	0.43	0.75
10.5	110.34	109.64	109.72	0.80	110.52	0.18	0.89
11.0	117.19	116.83	115.78	0.80	116.58	0.00	0.00
11.5	122.77	122.32	122.43	0.80	123.23	0.46	0.91
12.0	130.13	128.13	128.06	0.80	128.86	0.00	0.73
12.5	134.47	135.27	134.81	0.80	135.61	1.14	0.33
13.0	141.10	143.66	141.36	0.80	142.16	1.06	0.00
13.5	147.52	148.33	147.93	0.80	148.73	1.21	0.40
14.0	155.34	154.91	153.81	0.80	154.61	0.00	0.00
14.5	159.29	160.51	159.98	0.80	160.78	1.49	0.28
15.0	166.80	173.71	168.06	0.80	168.86	2.06	0.00
15.5	174.12	173.81	173.49	0.80	174.29	0.17	0.48
16.0	180.87	182.06	180.83	0.80	181.63	0.76	0.00
16.5	188.22	187.95	187.27	0.80	188.07	0.00	0.12
17.0	194.87	193.23	194.08	0.80	194.88	0.01	1.66
17.5	202.01	200.70	202.04	0.80	202.84	0.83	2.13
18.0	209.54	208.18	208.22	0.80	209.02	0.00	0.83
18.5	217.27	217.43	216.16	0.80	216.96	0.00	0.00
19.0	224.75	225.09	224.00	0.80	224.80	0.05	0.00
19.5	232.65	233.30	231.65	0.80	232.45	0.00	0.00
20.0	240.35	254.51	238.42	0.80	239.22	0.00	0.00

20.5	250.05	246.58	247.29	0.80	248.09	0.00	1.51
21.0	256.42	254.14	255.38	0.80	256.18	0.00	2.04
21.5	263.72	263.40	261.89	0.80	262.69	0.00	0.00
22.0	271.34	270.77	271.53	0.80	272.33	0.99	1.57
22.5	280.04	284.63	279.11	0.80	279.91	0.00	0.00
23.0	289.05	290.36	287.73	0.80	288.53	0.00	0.00
23.5	295.99	294.21	294.76	0.80	295.56	0.00	1.35
24.0	304.42	306.21	303.34	0.80	304.14	0.00	0.00
24.5	315.48	314.46	312.07	0.80	312.87	0.00	0.00
25.0	324.92	319.10	319.40	0.80	320.20	0.00	1.11
Average	144.81	145.29	144.00	0.80	144.80	0.40	0.45

Table 4.2-3 Demand and supply according to calculation (Matagente river)

Watershed	Dike Height / current land (supply)		Theoretical water level with a return period of 50 years	Dike Freeboard	Required dike's height (demand)	Diff. demand/supply	
	Left bank	Right bank				Left bank	Right bank
	①	②				③	④
0.0	2.58	2.16	2.22	0.80	3.02	0.44	0.85
0.5	3.40	4.85	5.26	0.80	6.06	2.66	1.21
1.0	6.55	6.50	7.22	0.80	8.02	1.47	1.52
1.5	10.00	10.11	10.17	0.80	10.97	0.97	0.85
2.0	13.43	15.09	13.71	0.80	14.51	1.08	0.00
2.5	17.07	20.06	17.69	0.80	18.49	1.43	0.00
3.0	22.03	24.12	21.63	0.80	22.43	0.39	0.00
3.5	27.56	27.50	26.13	0.80	26.93	0.00	0.00
4.0	31.51	31.24	30.47	0.80	31.27	0.00	0.04
4.5	35.58	35.32	34.51	0.80	35.31	0.00	0.00
5.0	41.98	40.32	40.01	0.80	40.81	0.00	0.49
5.5	45.86	45.19	44.84	0.80	45.64	0.00	0.45
6.0	50.08	48.81	49.14	0.80	49.94	0.00	1.13
6.5	54.35	55.04	53.40	0.80	54.20	0.00	0.00
7.0	59.08	57.82	58.08	0.80	58.88	0.00	1.06
7.5	63.40	62.51	62.98	0.80	63.78	0.38	1.27
8.0	68.88	67.69	67.28	0.80	68.08	0.00	0.39
8.5	73.29	72.83	72.72	0.80	73.52	0.23	0.69
9.0	78.20	77.68	78.60	0.80	79.40	1.20	1.72
9.5	83.40	82.77	83.25	0.80	84.05	0.66	1.28
10.0	89.48	89.30	88.98	0.80	89.78	0.29	0.48
10.5	96.85	95.26	95.01	0.80	95.81	0.00	0.55
11.0	101.96	101.83	100.37	0.80	101.17	0.00	0.00
11.5	107.51	106.67	106.03	0.80	106.83	0.00	0.16
12.0	115.71	113.02	112.27	0.80	113.07	0.00	0.05
12.5	120.34	120.84	120.40	0.80	121.20	0.86	0.36
13.0	126.80	126.53	126.68	0.80	127.48	0.69	0.95
13.5	133.51	133.18	133.00	0.80	133.80	0.29	0.62
14.0	139.51	138.84	139.07	0.80	139.87	0.36	1.03

14.5	146.29	146.59	145.46	0.80	146.26	0.00	0.00
15.0	152.42	153.14	152.17	0.80	152.97	0.55	0.00
15.5	158.48	157.91	158.34	0.80	159.14	0.67	1.24
16.0	166.41	165.40	164.64	0.80	165.44	0.00	0.04
16.5	171.68	171.66	170.82	0.80	171.62	0.00	0.00
17.0	178.50	178.55	177.38	0.80	178.18	0.00	0.00
17.5	185.97	184.93	184.22	0.80	185.02	0.00	0.09
18.0	193.35	191.73	190.81	0.80	191.61	0.00	0.00
18.5	199.11	198.68	197.79	0.80	198.59	0.00	0.00
19.0	206.87	205.53	204.36	0.80	205.16	0.00	0.00
19.5	214.30	214.28	213.56	0.80	214.36	0.06	0.09
20.0	222.43	221.28	220.84	0.80	221.64	0.00	0.36
20.5	229.93	230.02	228.96	0.80	229.76	0.00	0.00
21.0	237.01	236.42	234.90	0.80	235.70	0.00	0.00
21.3	238.88	240.30	238.30	0.80	239.10	0.22	0.00
21.8	246.95	250.05	245.04	0.80	245.84	0.00	0.00
22.3	255.59	256.42	253.48	0.80	254.28	0.00	0.00
22.8	267.12	263.72	261.25	0.80	262.05	0.00	0.00
23.3	275.04	271.34	270.12	0.80	270.92	0.00	0.00
23.8	279.22	280.04	278.31	0.80	279.11	0.00	0.00
24.3	299.88	289.05	285.93	0.80	286.73	0.00	0.00
24.8	303.56	295.99	293.62	0.80	294.42	0.00	0.00
25.3	304.42	306.21	303.29	0.80	304.09	0.00	0.00
Average	133.72	133.12	132.21	0.80	133.01	0.29	0.36

4.3 Technical Planning

4.3.1 Structural Measures

As structural measures it was necessary to prepare a flood control plan for the whole Watershed. The later section 4.15 “Medium and Long Term Plan” and 4.15.1 “General Flood Control Plan” details results on the analysis. This plan proposes the construction of dikes for flood control in the entire Watershed. However, in the case of the Watershed of Chincha river, a big project needs to be set up investing very high costs, far beyond those considered in the budget of the present Project, what makes it difficult to take this proposal. Therefore, supposing the flood control dikes in the whole Watershed are built progressively within a medium and long term plan, they would be focused on the study of more urgent and priority works for flood control.

(1) Design flood discharge

1) Guideline for flood control in Peru

The Methodological Guide for Projects on Protection and/or Flood Control in Agricultural or Urban Areas prepared by the Public Sector Multiannual Programming General Direction (DGPM) (present DGPI) of the Economy and Finance Ministry (MEF) recommends to carry out the comparative analysis of different return periods: 25 years, 50 years and 100 years for the urban area, and 10 years, 25 years and 50 years for rural area and agricultural lands.

Considering that the present Project is focused on the protection of rural and agricultural areas, the design flood discharge should be the discharge with return period of 10-year to 50-year.

2) Maximum discharge in the past and design flood discharge

The yearly maximum discharge in Chincha river is as shown in Figure-4.3.1. Based on the figure, the maximum discharge in the past can be extracted as shown in the Table- 4.3.1-1 together with the flood discharges with different return periods.

The maximum discharge in the past in the watershed occurred two times of which scale is more than the flood discharge with return period of 50-year. And it is true that the flood discharges of same scale as the flood discharge with return period of 50-year caused large damages in the past. The maximum discharge in the past in Chincha watershed occurred before 1960s, and the maximum discharges in recent 40 years are less than the discharge with return period of 50-year.

Since the flood control facilities in Peru not well developed, it is not necessary to construct the facilities for more than the maximum discharge in the past, however it is true that the past floods caused much disaster so that the facilities should be safe for the same scale of flood, therefore the design flood discharge in this Project is to be the discharge with return period of 50-year.

Table - 4.3.1-1 Flood discharge with different return period (m³/sec)

Watershed	2-year	10-year	25-year	50-year	100-year	Max. in the Past
Chincha	203	580	807	917	1,171	1,269

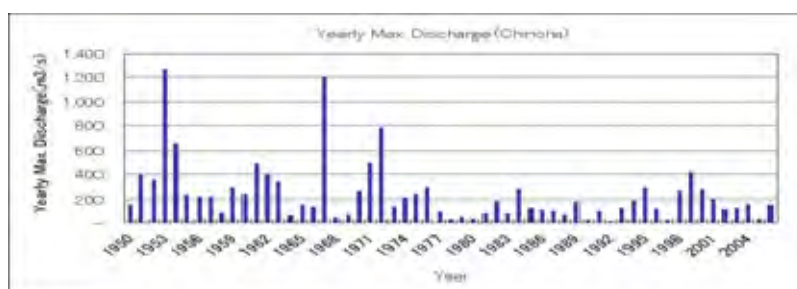

Figure- 4.3.1-1 Yearly max. discharge (Chincha)

3) Relation among probable flood, damage and inundation area

The relation among probable flood, Damage and inundation area in Chincha river are shown in the Figure-4.3.1-2. Based on the figures the following facts can be expressed.

- ① The more increase probable flood discharge, the more increase inundation area (green line in the figure).
- ② The more increase probable flood discharge, the more increase damage (red line in the figure).

- ③ According to increase of probable flood discharge, the damage with project increase gently (blue line in the figure).
- ④ According to increase of probable flood discharge, damage reduction (difference between red line and blue line) increase steadily, and it reaches maximum at the probable flood of 50- year within the scope of study.

The damage reduction amount in the design discharge is largest among the probable flood discharge less than with return period of 50-year, and economic viability of the design flood is confirmed. Although the design discharge is the flood with return period of 50-year, the inundation area of the flood with return period of 100-year is described in the figures.

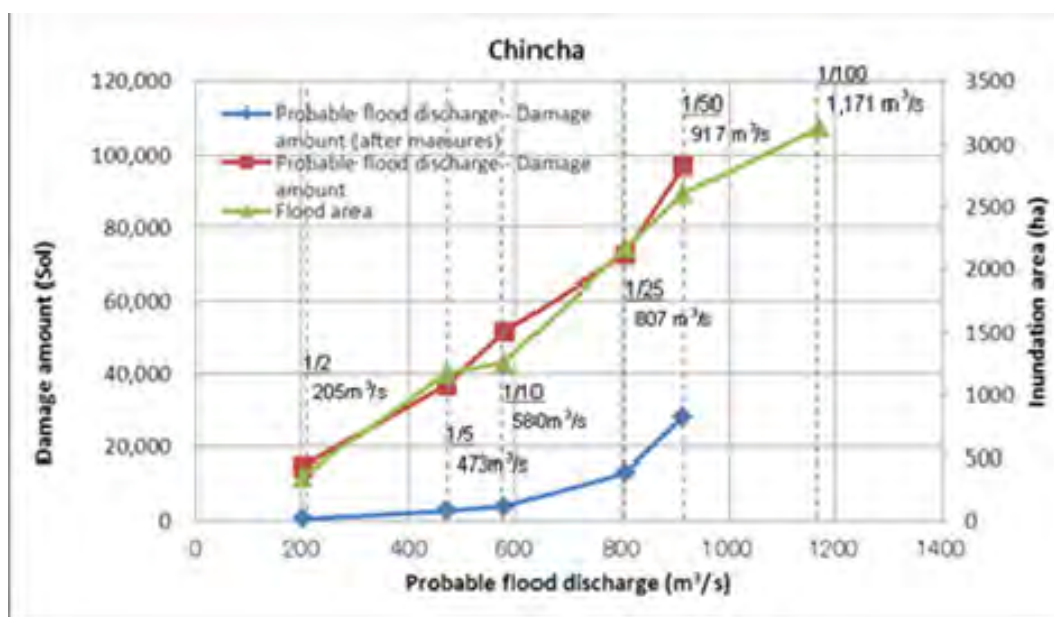

Figure—4.3.1-2 Probable flood discharge, damage amount and inundation area (Chincha river)

(2) Topographical survey

The topographical survey was carried out in selected places for the execution of structural measurements (Table 4.3.1-1). The preliminary design of control works was based on these topographical survey results.

Table 4.3.1-1 Summary of topographical survey

River	Location (No.)	Installations	Topo lift.	Transversal Lifting (S=1/200)		
			(ha)	Line No.	Middle length (m)	Total length (m)
Chincha	Chico-1	Dike	15.0	32	50.0	1,600
	Chico-2	Reservoir	21.0	8	300.0	2,400
	Chico-3	Reservoir	5.0	4	200.0	800
	Ma-1	Dike	15.0	32	50.0	1,600
	Ma-2	Dike & excavation	24.0	13	200.0	2,600
Sub Total			80.0	89		9,000

(3) Selection of flood protection works with high priority

1) Basic guidelines

For the selection of priority flood protection works, the following elements were considered:

- Demand from the local community (based on historical flood damage)
- Lack of discharge capacity of river channel (including the sections affected by the scouring)
- Conditions of the adjacent area (conditions in urban areas, farmland, etc.).
- Conditions and area of inundation (type and extent of inundation according to inundation analysis)
- Social and environmental conditions (important local infrastructures)

Based on the river survey, field investigation, discharge capacity analysis of river channel, inundation analysis, and interviews to the local community (irrigation committee needs, local governments, historical flood damage, etc...) a comprehensive evaluation was made applying the five evaluation criteria listed above. After that we selected a total of five (5) critical points (with the highest score in the assessment) that require flood protection measures.

Concretely, since the river cross sectional survey was carried out every 500m interval and discharge capacity analysis and inundation analysis were performed based on the survey results, the integral assessment was also done for sections of 500 meters. This sections have been assessed in scales of 1 to 3 (0 point, 1 point and 2 points) and the sections of which score is more than 6 were selected as prioritized areas. The lowest limit (6 points) has been determined also taking into account the budget available for the Project in general

Table 4.3.1-3 details evaluated aspects and assessment criteria.

Table 4.3.1-3 Assessment aspects and criteria

Assessment Aspects	Description	Assessment Criteria
Demand of local population	<ul style="list-style-type: none"> ● Flood damages in the past ● Demand of local population and producers 	<ul style="list-style-type: none"> • Flooding area with big floods in the past and with great demand from local community (2 points) • Demand of local population (1 point)
Lack of discharge capacity (bank scouring)	<ul style="list-style-type: none"> ● Possibility of river overflow given the lack of discharge capacity ● Possibility of dike and bank collapse due to scouring 	<ul style="list-style-type: none"> • Extremely low discharge capacity (discharge capacity with return period of 10 years or less) (2 points) • Low discharge capacity (with return period of less than 25 years) (1 point)
Conditions of surrounding areas	<ul style="list-style-type: none"> ● Large arable lands, etc. ● Urban area, etc. ● Assessment of lands and infrastructure close to the river. 	<ul style="list-style-type: none"> • Area with large arable lands (2 points) • Area with arable lands mixed with towns, or big urban area (2 points) • Same configuration as the previous one, with shorter scale (1 point)
Inundation conditions	<ul style="list-style-type: none"> ● Inundation magnitude 	<ul style="list-style-type: none"> • Where overflow extends on vast surfaces (2 points) • Where overflow is limited to a determined area (1 point)
Socio-environmental conditions (important structures)	<ul style="list-style-type: none"> ● Intake of the irrigation system, drinking water, etc. ● Bridges and main roads (Carretera Panamericana, etc.) 	<ul style="list-style-type: none"> • Where there are important infrastructures for the area (2 points) <p>Where there are important infrastructures (but less than the first ones) for the area (regional roads, little intakes, etc.) (1 point)</p>

2) Selection results

Figure 4.3.1-3 and Figure 4.3.1-4 detail assessment results of the river, as well as the selection results of flood protection priority works.

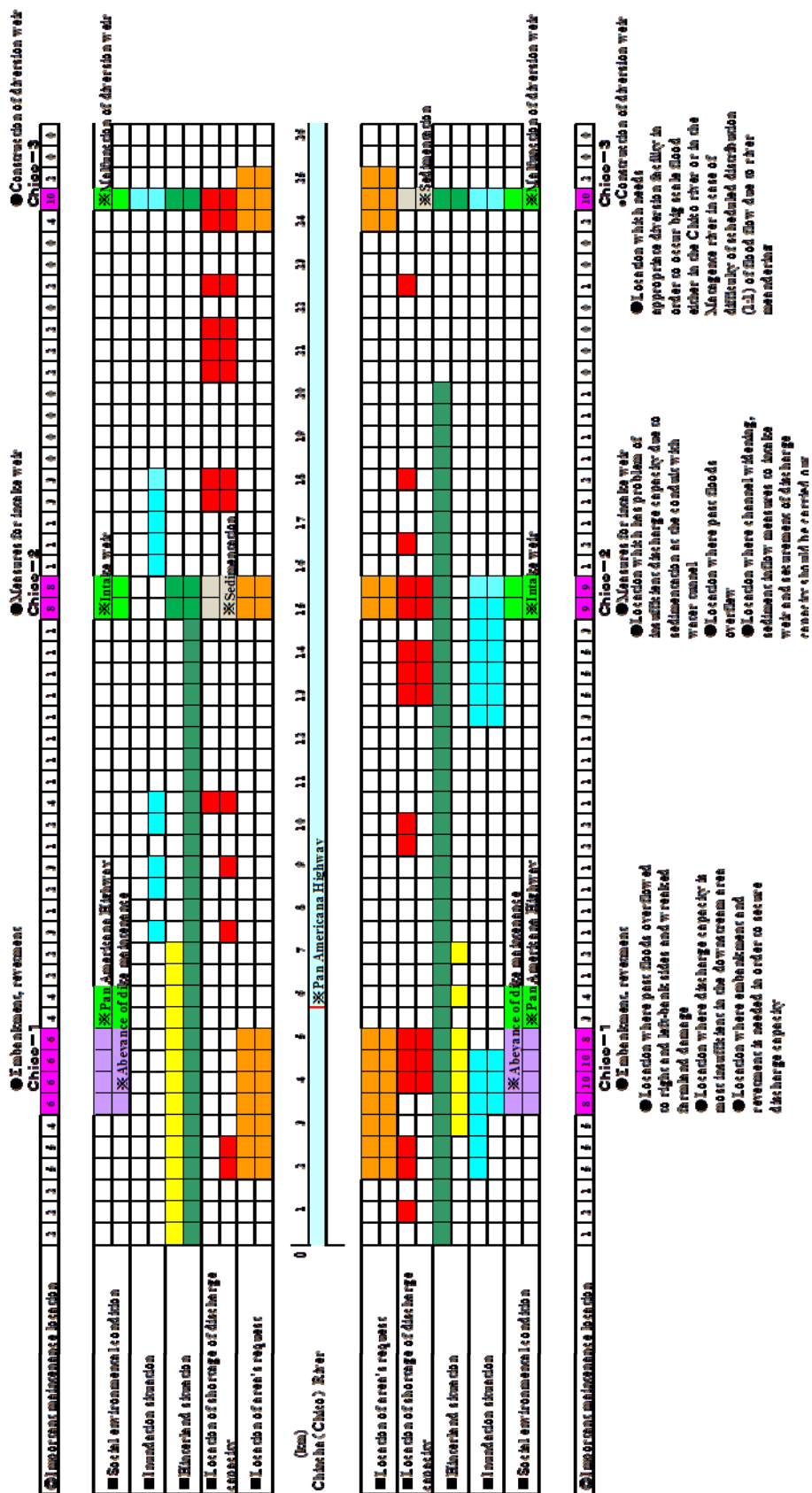

Figure 4.3.1-3 Selection results of prioritized flood protection works in Chincha-Chico river

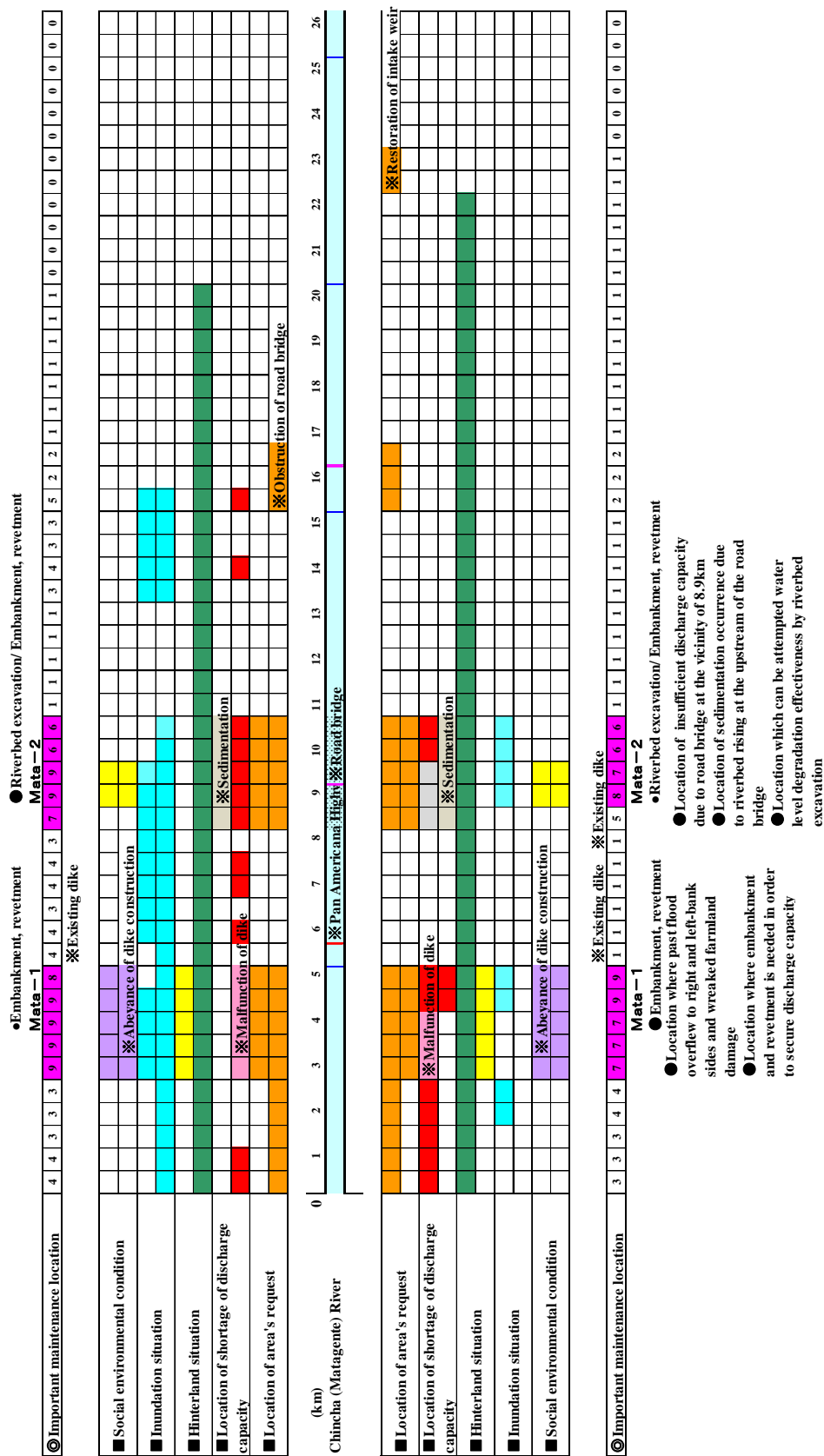

Figure 4.3.1-4 Selection results of prioritized flood protection works in Chincha-Matagente river

3) Basis of selection

The characteristics of Chincha river is that in case of unequal diversion of flood water to Chico river and Matagente river , the flooding water inflow unevenly to one river causing heavy damage in all section of that river due to insufficient discharge capacity. Even when the water is adequately distributed among rivers Chico and Matagente in a 1:1 relation, Chico River may overflow at Km 15 and Km 4 causing great damages on the left bank, and Matagente River may overflow at Km 9 and Km 3, flooding great areas from right bank.

Therefore, the basic policy of flood prevention is to build the diversion weir and embankment with bank protection in the section where inundation areas in the past due to insufficient discharge capacity. The flood prevention works are planned on the condition that the discharge is distributed equally to the both rivers as the each river channel has same scale (in case of execution of No.③). There is no discharge distribution plan at present.

Table 4.3.1-4 Selected sections bases to execute works (Chincha river)

No	Location	Basis of Selection
i)	Chico river 3.0km~5.1km (both banks)	<p>The embankment with bank protection is required in this section where the discharge capacity is lowest in the lower reach of Chico river, especially for the left bank to prevent the damage increasing. And in case that the flood protection work is constructed in the upstream section, inundation occurs and enlarges in the right bank. Therefore the embankment at both banks is required.</p> <p>[Characteristics of the section]</p> <ul style="list-style-type: none"> ●Section in which the past inundations on both banks have caused damages on crops, etc ●Section only the left bank dike is partially built. If dikes are constructed in upstream sections, this may lead to inundation in this section ●The section with the lowest discharge capacity in the lower reach <p>[Elements to protect]</p> <ul style="list-style-type: none"> ○Vast agricultural lands that go beyond both banks of this section (especially on the left bank) <p>[Method of Protection]</p> <ul style="list-style-type: none"> ▼Inundation occurs at the flood with return period of 5-year and the damage become heavily at the flood with return period of 50-year, so that the flood protection work is implemented for the latter flood flowing down safely. ▼Embankment with bank protection is built for securing the discharge capacity utilizing the existing dike partially
ii)	Chico river 14.8km~15.5km (widening the river with to left bank)	<p>This section has the problem of accumulating great amounts of sediments in the intakes and has an absolute lack of discharge capacity already mentioned. So, it is a very important section where the control of sediments to the intake (construction of a derivation work that distributes the flow correctly) and ensuring the required discharge capacity are the main tasks.</p> <p>[Characteristics of the section]</p> <ul style="list-style-type: none"> ●Section that inundated due to former floods ●Section that requires widening river, control of sediments in the intake and keeping the necessary discharge capacity ●Section where a water channel tunnel exists, in which sediments have deposited, and stops the function of tunnel. <p>[Elements to protect]</p> <ul style="list-style-type: none"> ○Intake ○Left bank crop lands <p>[Method of Protection]</p>

		<p>▼ Inundation occurs at the flood with return period of 5-year and the damage become heavily at the flood with return period of 50-year, so that the flood protection work is implemented for the latter flood flowing down safely.</p> <p>▼ Widening river width and preventing the concentration of flow to the intake</p>
iii)	<p>Chico river</p> <p>Km24.2-km24.5 (total)</p>	<p>This section is a diversion point of Chincha river to Chico river and Matagente river, and the most important section in the flood prevention plan for Chincha river (Base of flood prevention plan).</p> <p>The diversion weir exists at the section; however it was built in 1954, and heavily devastated. And in flooding the flow meanders in the upstream of the weir and water flows in the one of two rivers, which means diversion is not well functioned. Therefore the construction of diversion weir to distribute the flood evenly is indispensable in the flood control in Chincha river</p> <p>[Characteristics of the section]</p> <ul style="list-style-type: none"> ● Section that requires a proper derivation work because in case that it is not possible to distribute stream in a relation 1:1 due to the river meandering. This will cause great flooding in one of both rivers: Chico or Matagente <p>[Elements to protect]</p> <ul style="list-style-type: none"> ○ Every district of Chico and Matagente (because if the overflow stream is not adequately distributed, great damage will happen in one of both rivers) <p>[Method of Protection]</p> <p>▼ The diversion weir which can divert the flow steadily is constructed.</p>
iv)	<p>Matagente J </p> <p>2.5km~5.0km (both banks)</p>	<p>This section is past inundation area with tendency of spreading widely to the right bank. And the irregular embankment was implemented for preventing the past damage. If the flood prevention work in the upstream is executed, inundation occurs in left bank also so that the embankment is required at both banks.</p> <p>[Characteristics of the section]</p> <ul style="list-style-type: none"> ● Section with lowest discharge capacity in downstream ● Section in which the past floods have caused inundation on both banks causing great damages to croplands, etc. ● Section where dikes were irregularly constructed. <p>[Elements to protect]</p> <ul style="list-style-type: none"> ○ Vast agricultural lands that spreads beyond both banks of this section (specially on the right bank) <p>[Method of Protection]</p> <p>▼ Construction of dike to improve insufficient discharge capacity and bank protection to covering slope and end of slope</p> <p>▼ Inundation occurs at the flood with return period of 5-year and the damage become heavily at the flood with return period of 50-year, so that the flood protection work is implemented for the latter flood flowing down safely.</p>
v)	<p>Matagente J </p> <p>8.0km~10.5km (both banks)</p>	<p>This section is the past inundation area. In this narrow section (where the bridge is built), the discharge capacity is insufficient and the river bed has raised 4 – 5 m during past 50 years. The river bed needs to be excavated to increase the discharge capability (taking the proper precautions in order not to damage the bridge's base) and a dike must be built on both banks.</p> <p>[Characteristics of the section]</p> <ul style="list-style-type: none"> ● Section where sediments deposited upstream of the bridge due to its damming up effect

		<ul style="list-style-type: none"> ●Section in which the discharge capacity is very reduced due to the river's narrowness at km 8.9 (where the bridge is) <p>[Elements to protect]</p> <ul style="list-style-type: none"> ○ Vast agricultural lands that go beyond both banks of this section (especially on the right bank) <p>[Method of Protection]</p> <ul style="list-style-type: none"> ▼This section has tendency of riverbed raising so that riverbed excavation is to be executed for keeping discharge capacity and lowering upstream water level. ▼Inundation occurs at the flood with return period of 5-year and the damage become heavily at the flood with return period of 50-year, so that the flood protection work is implemented for the latter flood flowing down safely.
--	--	--

(4) Location of prioritized flood control works

Figure 4.3.1-5 shows the location of priority works on flood control in the Chincha river, and The Table 4.3.1-5 shows the summary of the priority works.

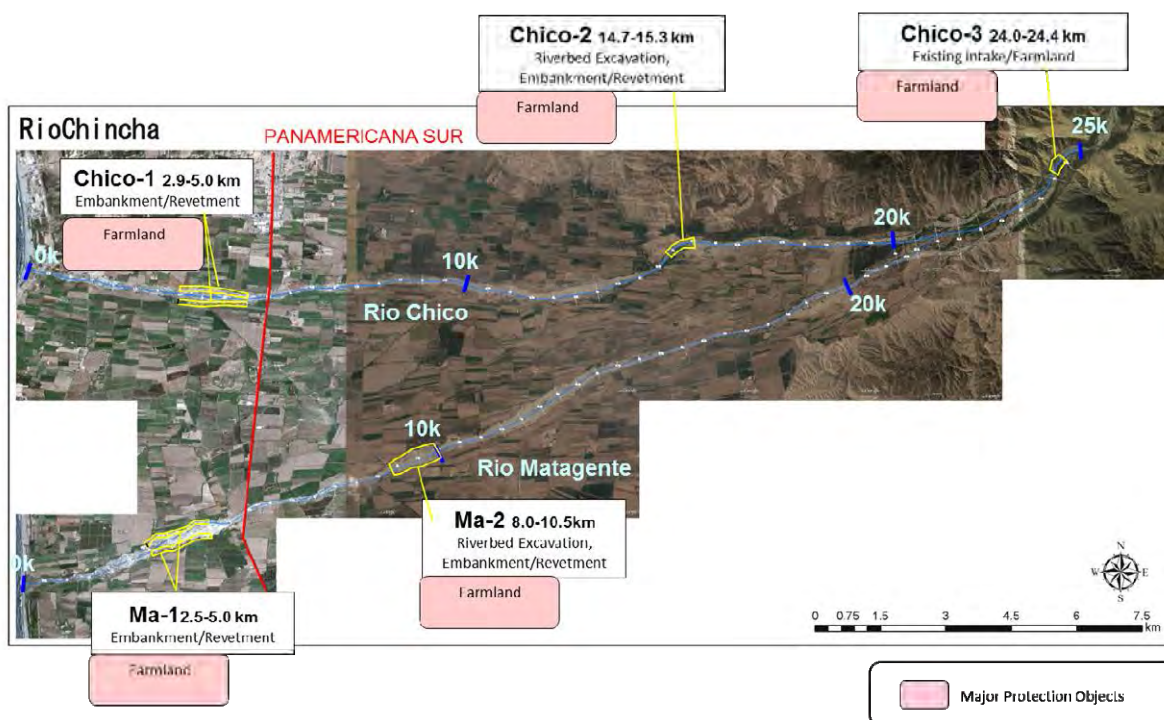

Figure 4.3.1-5 Prioritized flood control works in Chincha river

Table 4.3.1-5 Summary of priority works

River	Location		Critical Point	Main Protection Objects	Measure	Feature of Work	
Rio Chincha	Chico-1	2.9-5.0 km	Innuded Point	Agricultural Lands (Apple, Grape, Cotton, etc.), Intake Weir	Dike with Bank Protection	Length Dike with Bank Protection Large Boulder Riplap	3,150 m 60,160 m ³ 23,700 m ³
	Chico-2	14.7-15.3 km	Existion Intake Weir (w:100m, H:3.0m, crest w:2.0m)		Riverbed excavation, Dike with Bank Protection	Riverbed Excavation Dike with Bank Protection Large Boulder Riplap	L=540 m, V=20,000 m ³ L=850 m, V=5,500 m ³ 23,700 m ³
	Chico-3	24.0-24.4 km	Existing Intake Weir (w:70m, H: 3.0m, crest w:2.0m)		Intake Weir/ Dike with Bank Protection	Construction of Intake Weir Dike with Bank Protection Large Boulder Riplap	Ground Sill 1 V=5,200 m ³ , Diversion Weir 1 V=4,300 m ³ L=730 m, V=20,350 m ³ 7,400 m ³
	Ma-1	2.5-5.0 km	Innuded Point		Dike with Bank Protection	Length Dike with Bank Protection Large Boulder Riplap	4,630 m 49,900 m ³ 37,000 m ³
	Ma-2	8.0-10.5km	Narrow Section		Riverbed excavation, Dike with Bank Protection	Riverbed Excavation Dike with Bank Protection Large Boulder Riplap	L=2,500 m, V=123,500 m ³ L=4,080 m, V=37,700 m ³ 32,200 m ³

(5) Standard section of the dike

1) Width of the crown

The width of the dike crown was defined in 4 meters, considering the dike stability when facing design overflows, width of the existing dike, and width of the access road or that of local communication.

2) Dike structure

The dike structure has been designed empirically, taking into account historic disasters, soil condition, condition of surrounding areas, etc.

Dikes are made of soil in all the Watersheds. Although there is a difference in its structure varying from area to area, this can be summarized as follows, based on the information given by the administrators interviewed:

- ① The gradient of the slope is mainly 1:2 (vertical: horizontal relationship); the form may vary depending on rivers and areas.
- ② Dike materials are obtained from the river bed in the area. Generally these are made of sand/gravel ~sandy soil with gravel, of reduced plasticity. As to the resistance of the materials, we cannot expect cohesiveness.
- ③ The Watershed of the Cañete River is made of loamy soil with varied pebble, relatively compacted.
- ④ The lower stretch of the Sullana weir of the Chira River is made of sandy soil mixed with silt. Dikes have been designed with a “zonal-type” structure where material with low permeability is placed on the riverside of the dike and the river; material with high permeability is placed on landside of the dike. However, given the difficulty to obtain material with low permeability, it has been noticed that there is lack of rigorous control of grain size distribution in supervision of construction.
- ⑤ When studying the damaged sections, significant differences were not found in dike material or in the soil between broken and unbroken dike. Therefore, the main cause of destruction has been water overflow.
- ⑥ There are groins in the Chira and Cañete rivers, and many of them are destroyed. These are made of big rocks, with filler material of sand and soil in some cases, what may suggest that destruction must be caused by loss of filler material.
- ⑦ There are protection works of banks made of big rocks in the mouth of the Pisco River. This structure is extremely resistant according to the administrator. Material has been obtained from quarries, 10 km. away from the site.

Therefore, the dike should have the following structure.

- ① Dikes will be made of material available in the zone (river bed or banks). In this case, the material would be sand and gravel or sandy soil with gravel, of high permeability. The stability problems forecasted in this case are as follows.

- i) Infiltrate destruction caused by piping due to washing away fine material
- ii) Sliding destruction of slope due to infiltrate pressure

In order to secure the stability of dike the appropriate standard section should be determined by infiltration analysis and stability analysis for sliding based on unit weight, strength and permeability of embankment material.

- ② The gradient of the slope of the dike will be between $30^\circ \sim 35^\circ$ (angle of internal friction) if the material to be used is sandy soil with low cohesiveness. The stable gradient of the slope of an embankment executed with material with low cohesiveness is determined as: $\tan\theta = \tan\phi/n$ (where “ θ ” is gradient of the slope; “ ϕ ” is angle of internal friction and “ n ” is 1.5 ,safety factor).

The stable slope required for an angle of internal friction of 30° is determined as: V:H=1:2.6 ($\tan\theta=0.385$).

Taking into consideration this theoretical value, a gradient of the slope of 1:3.0 was considered, with more gentle inclination than the existing dikes, considering the results of the discharge analysis, the prolonged time of the design flood discharge (more than 24 hours), the fact that most of the dikes with slope of 1:2 have been destroyed, and the relative resistance in case of overflow due to unusual flooding.

The infiltration analysis and stability analysis of dike based on the soil investigation and martial tests are not performed in this Study so that the slope is determined by simple stability analysis assuming the strength factors of dike material estimated by field survey of material and by adding some safety allowance.

And the slope of dike in Japan is generally 1:2.0 in minimum, however the average slope will be more than 1:3.0 because the dike has several steps in every interval of 2m~3m of height.

- ③ The dike slope by the riverside must be protected for it must support a fast water flow given the quite steep slope of the riverbed. This protection will be executed using big stones or big rocks easily to get in the area, given that it is difficult to get connected concrete blocks.

The size of the material was determined between 30cm and 1m of diameter, with a minimum protection thickness of 1m, although these values will be determined based on flow speed of each river.

- ④ The penetration depth to bank protection is to be i) difference height between the deepest riverbed in the past and present riverbed or ii) empirical depth (0.5m~1.5m in Japan), the former is u certain without chronological riverbed fluctuation data, therefore according to the latter the depth is to be 1.75m referring to the river channel improvement section in Ica river

- ⑤ Heightening method of dike

The heightening length of existing dike is 0.6 km among the total length of dike construction of 13.2 km in Chincha.

The heightening method of dike is basically an overall enlargement type due to the following reasons and the alignment of dike accords with the one of exiting dike.

- i) The heightening method of widening dike in riverside decreases river width so that the discharge capacity is reduced resulting in raising height of dike more than the other methods.
- ii) The heightening method of widening dike in land side requires more land acquisition. It is desirable that the land acquisition is to be reduced as much as possible because the land is mainly important agricultural land of expensive.
- iii) Although the workmanship of dike construction such as the compaction condition and material characteristics are unknown, the existing dike is to be utilized because the dike has been functioned in the past flooding, and the heightening method of overall enlargement type is to be applied, in which the existing dike is covered by the new dike with high strength, and can secure the safety and be economical with less land acquisition.

On the other hand, in the section with the narrow river width and river channel near to the dike, the heightening method of widening dike in land side is applied, in this case the riverside slope is protected with revetment.

3) Freeboard of the dike

The dike is made of soil material, and as such, it generally turns to be an weak structure when facing overflow. Therefore, it is necessary to prevent water overflow, to a lower water rise than the design discharge. So it is necessary to keep a determined freeboard when facing a possible increase in water level caused by the waves by the wind during water rise, tidal, hydraulic jump, etc. Likewise, it is necessary that the dikes have sufficient height to guarantee safety in surveillance activities and flood protection work , removal of logs and other carryback material, etc.

Table 4.3.1-6 shows guidelines applied in Japan regarding freeboard. Although in Peru there is a norm on freeboard, it has been decided to apply the norms applied in Japan, considering that rivers in both countries are alike.

Table-4.3.1-6 Design discharge and freeboard

Design discharge	Freeboard
Less than 200 m ³ /s	0.6m
More than 200 m ³ /s, less than 500 m ³ /s	0.8m
More than 500 m ³ /s, less than 2,000 m ³ /s	1.0 m
More than 2,000 m ³ /s, less than 5,000 m ³ /s	1.2 m
More than 5,000 m ³ /s, less than 10,000 m ³ /s	1.5 m
More than 10,000 m ³ /s	2.0 m

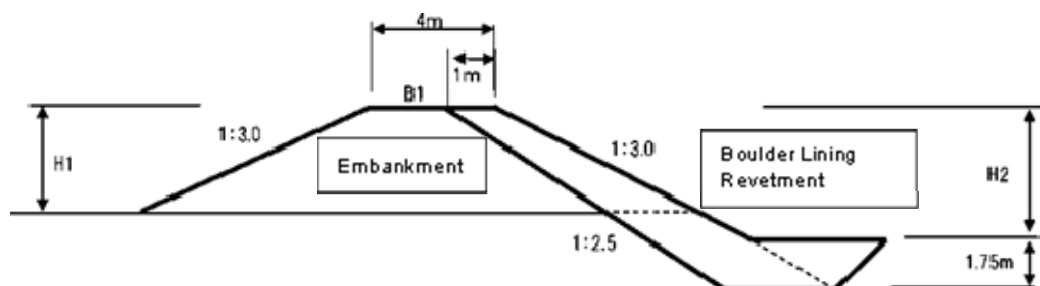

Figure 4.3.1-6 Standard dike section

4) Importance in construction work

The importance in dike construction is sufficient compaction of dike material. The cost estimate standard in Peru the compaction is to be made by tractor; however for the sufficient compaction it is desirable to use compaction equipment such as vibration roller etc.

And in order to supervise the compaction of material, the density test and grain size analysis are important, of which are specified in the technical specification of the tender document.

(6) Effect of flood prevention facilities

The discharge capacity of each river is enlarged up to the flood discharge with return period of 50-year by construction of the flood prevention facilities as shown in the Figure-4.3.1-7 and the Figure-4.3.1-8 , and the inundation area is reduced remarkably.

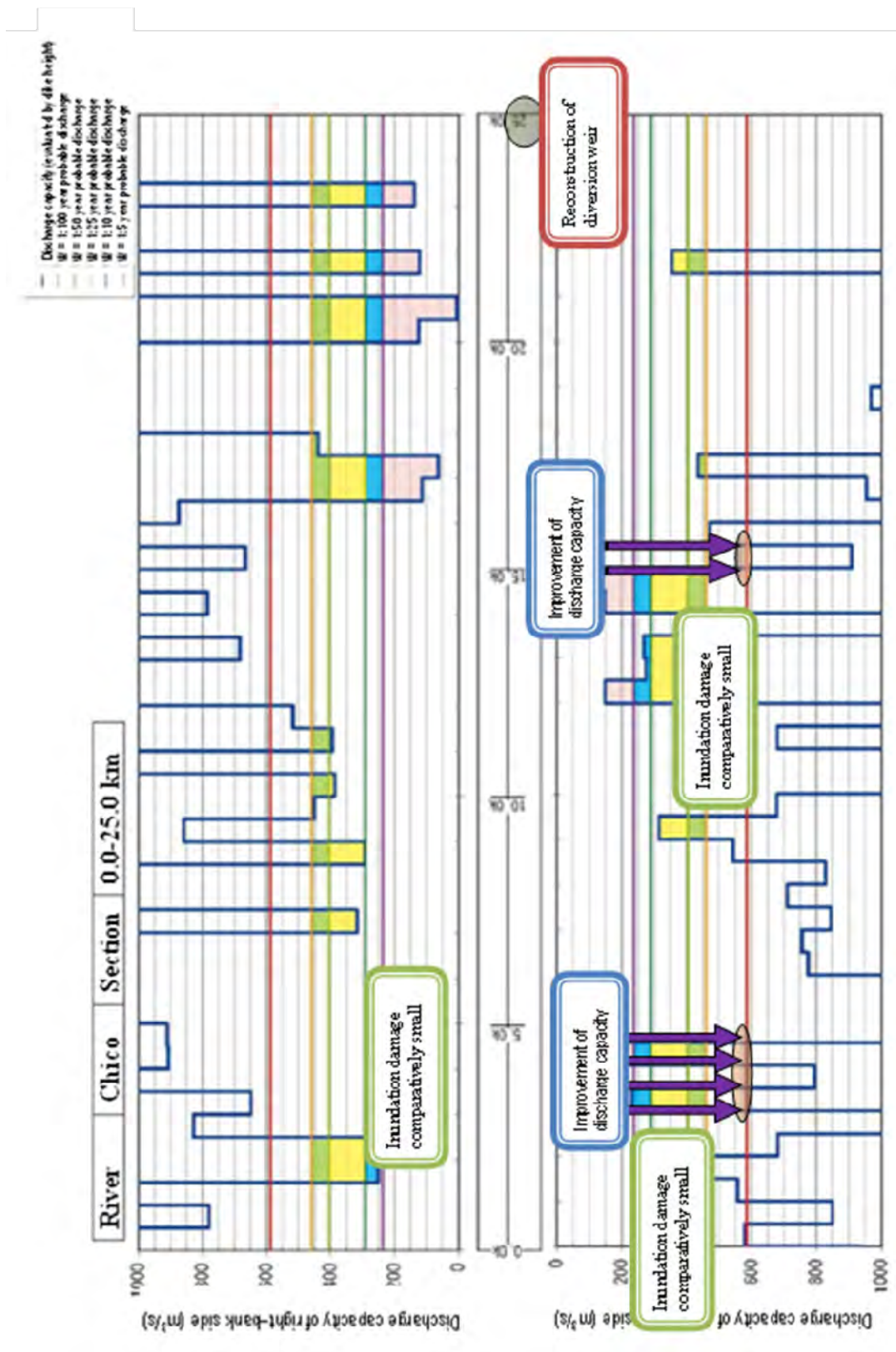

Figure-4.3.1-7 Effect of flood prevention facilities (Rio Chincha – Rio Chico)

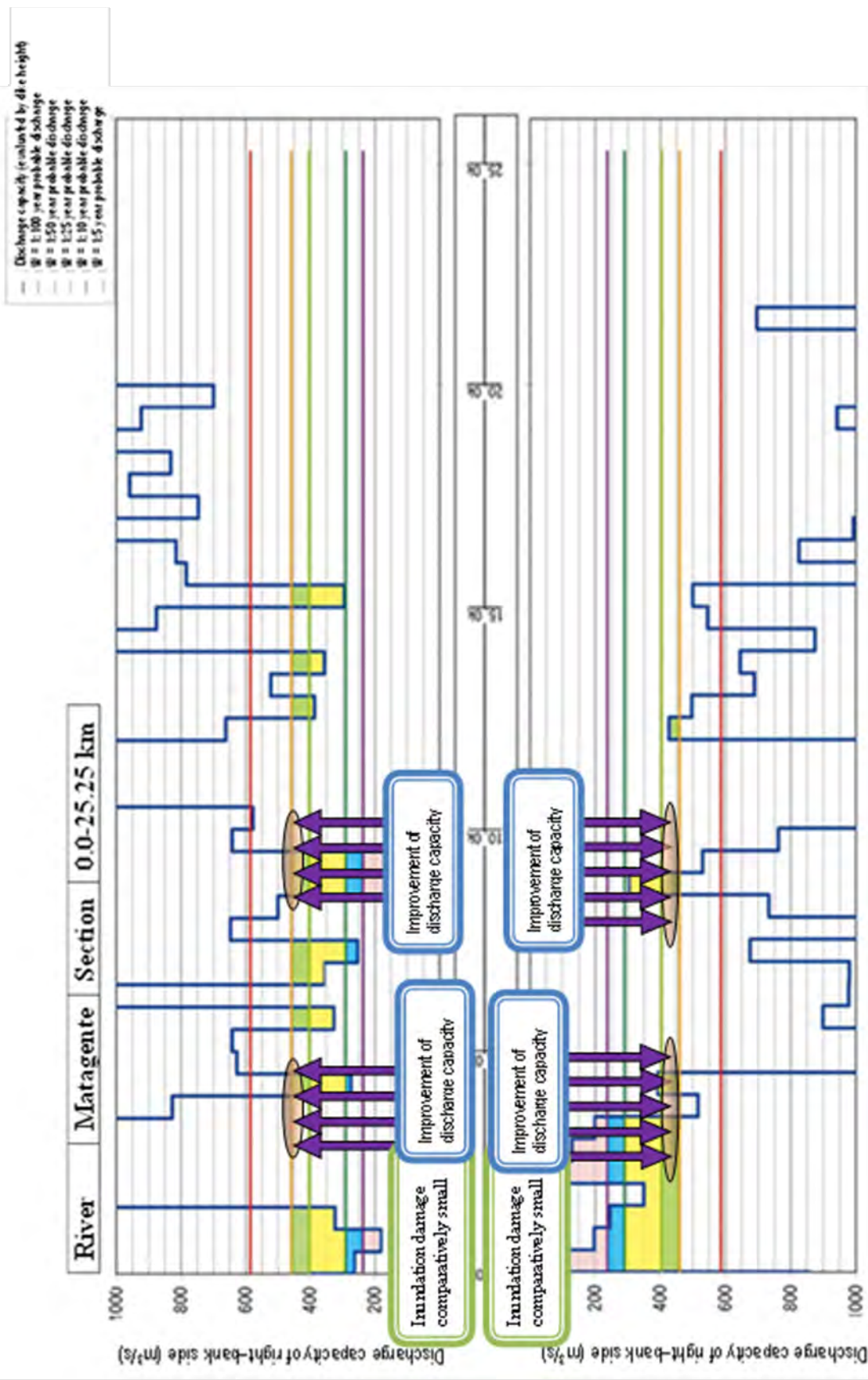

Figure-4.3.1-8 Effect of flood prevention facilities (Rio Chincha – Rio Matagente)

4.3.2 Nonstructural Measures

4.3.2.1 Reforestation and Vegetation Recovery

(1) Basic policies

The Reforestation and Vegetation Recovery Plan satisfying the goal of the present Project can be classified in: i) reforestation along fluvial works; and ii) reforestation in the high Watershed. The first one contributes directly to flood control and expresses its effect in short time. The second one demands a huge investment and an extended time, as detailed in the later section 4.15 “Medium and long term Plan”, 4.15.2 “Reforestation Plan and Vegetation Recovery”, what makes not feasible to implement it in the present Project. Therefore, the analysis is here focused only in option i).

(2) Reforestation plan along river structures

Policies for the afforestation plan along river structure is as shown below. The conceptual diagram of the afforestation scheme are shown in Figures 4.3.2.1-1.

- a) Objective: Reduce impact of river overflow when water rise occurs or when river narrowing is produced by the presence of obstacles, by means of vegetation borders between the river and the elements to be protected.
- b) Methodology: Create vegetation borders of a certain width between river structures and the river.
- c) Work execution: Plant vegetation at a side of the river structures (dikes, etc.) is to be a part of construction work of river structures, and which is carried out by the same contractor as for the river structures. The reasons are i) plant vegetation is to be certain for the withered damage just after plantation and ii) The same contractor for the river structures is appropriate due to the parallel work of plantation and structure construction.
- d) Maintenance post reforestation: The maintenance will be assumed by irrigation commissions by own initiative. In the past project, it is usually performed that the agreement is made between the irrigation committee and DGIH on the following two items.
 - i) The ownership of plantation belongs to the irrigation committee.
 - ii) Operation and maintenance cost of the plantation is born by the committeeTherefore the plantation is not private property but public one in the committee.
- e) Plantation section : Since the purpose of plantation is mitigation of damage in overflowing of flood, the plantation is to be made in the preventive side of dike. In case that the plantation is made in the section without dike, the trees are knocked down directly by flood water, and they flow down along river causing the choke in the bridges etc. resulting in secondary damage, and as the length without dike is long , the cost of construction and land acquisition increases.

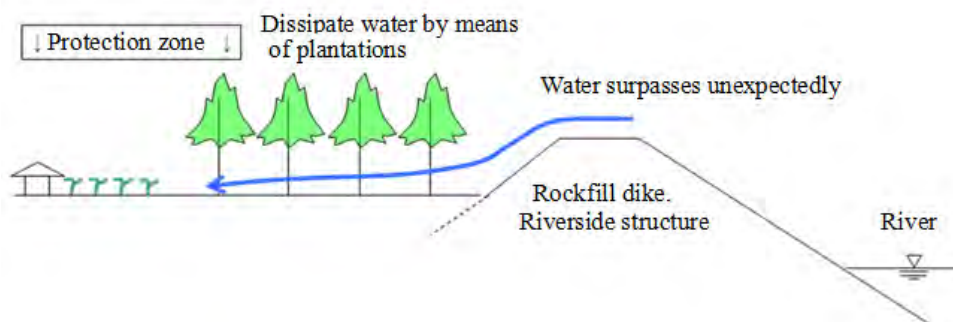

source: JICA Study Team)

Figure 4.3.2.1-1 Conceptual diagram afforestation in the riverside structures

(3) Reforestation plan

1) Structure (plantation arrangement)

In Peru the most common pattern for afforestation is with equilateral triangles. This project also uses this model by planting trees with 3-meter intervals (Figure 4.3.2.1-2). If this method is used, the interval of trees vertical to the dike will be 2.6m and in the case of zigzag arrangement, the width will be 1.3m of which interval can stop the boulder with diameter of 1m or dissipate the energy of the boulder. And 4 lines of trees can increase the effect. Thus the width of plantation zone will be 11 m adding the allowance to 10.4 m.

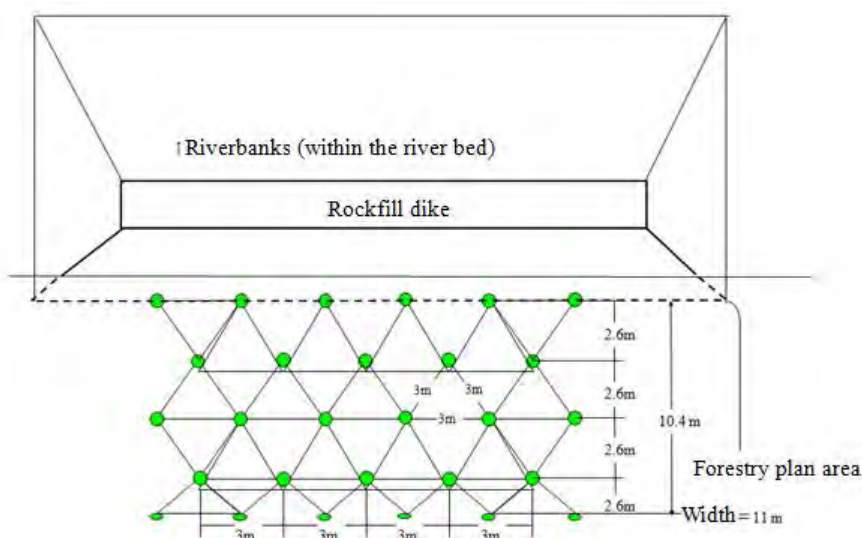

(Source: JICA Study Team)

Figure 4.3.2.1-2 Arrangement of plantation along river structure

2) Species to be forested

The following list of forestry species has been developed for selecting the species to be planted.

- Forestry species for production (information obtained by forest nursery companies): see Table 4.3.2.1-1

- Forestry species verified in situ: see Table 4.3.2.1-2.

The mentioned species are selected for afforestation in bank structures. For selecting them, an evaluation was conducted considering certain criteria. In Table 4.3.2.1-3 shows the details of the selection, in Table 4.3.2.1-4 you can find the Table with the selection criteria.

Evaluation criteria used for selection:

- i) Species with adequate properties to grow and develop in the riverside (preferably native)
- ii) Possibility of growing in plant nurseries
- iii) Possibility of wood and fruit use
- iv) Demand of local population
- v) Native species (preferably)

After making a field survey, a list of planted or indigenous species of each zone was firstly made. Then, a list of species whose plants would grow in seedbeds, according to interviews made to plant growers, was prepared.

Priority was given to the aptitude of local conditions and to plant production precedents, leaving as second priority its usefulness and demand or if they were native species or not. Table 4.3.2.1-4 shows the assessment criterion.

Table 4.3.2.1-1 List of seedlings that may be produced

Watershed	Producers	Seedlings production sites	Commonly produced species	Sporadic produced species
Chincha	AGRORURAL	Lima	Pino, Molle, Eucalipto, Huarango (<i>Prosopis limensis</i>)	Ciprés, Tara
	Fomeco	Lima	Tara, Molle, Huarango (<i>Prosopis limensis</i>)	
	AGRORURAL	Ica	Aliso, Algarrobo, Caña, Tamarix, Bambú, Pino, Casuarina, Eucalipto	

(Source: Information gathered by the forestry seedlings producers)

Table 4.3.2.1-2 List of verified tree species in the field (for riparian forestation)

Location	Tree Species	Characteristics
Chincha	Molle	It has good track record in plantation/forestation, its characteristics shows high adequateness.
	Eucalipto	Common along the river, and its characteristics shows high adequateness.

(Source: JICA study team)

Table 4.3.2.1-3 Results of planting species selection (details)

River Basin	Tree Species	Adequateness to evaluation items*						Remarks
		1	2	3	4	5	Total**	
Chincha	Aliso	C	B	A	C	A	--	Adequate for high elevation areas rather as Similar to Huarango (<i>Prosopis limensis</i>), Prosopis is selected in the southern areas Grass Adequate for high elevation areas rather as Adequate for high elevation areas rather as Its characteristics shows high adequateness in the Northern areas, but unknown in the southern areas Recently, fruit was found as effectiveness, becomes popular for plantation Unknown for forestation record Adequate for high elevation areas rather as It is said as its root grows in deep Adequate for high elevation areas rather as Adequate for high elevation areas rather as Its characteristics shows high adequateness in the area near to the sea or dry area
	Algarrobo	B	A	C	B	A	--	
	Canya (Cariso)	A	C	B	B	A	--	
	Quinual	C	C	B	C	A	--	
	Colle	C	D	D	B	A	--	
	Tamalix	B	A	B	B	B	--	
	Tara	D	A	A	B	A	-	
	Bamboo	A	A	B	B	A	+	
	Pine	B	D	B	B	B	-	
	Molle	B	A	B	B	A	+	
	Casuarina	A	B	C	B	B	+	
	Eucalyptus	A	B	B	A	B	++	
Huarango (<i>Prosopis limensis</i>)	A	A	D	A	A	++		

* Evaluation criteria are shown above, ** ++: Selected, +: second, -: nominated but not so good,--: not be selected

(Source: JICA Study Team based on hearing from the seedling providers)

Table 4.3.2.1-4 Assessment criterion for forest species selection

		Assessment Criterion				
		1	2	3	4	5
Assessment points	A	In situ testing (natural or reforested growth)	Major production	Possible use as wood or for fruit production	Water demand by the Users Committee, among others	Local specie
	B	Growth has not been checked in situ, however it adapts in the zone	Sporadic production	Possible use as wood or for fruit production	There is NO water demand by the Users Committee	No local specie
	C	None of the above	Possible reproduction but not usual	No use as wood nor fruit	—	—
	D	Unknown	Not produced	Unknown	—	—

(Source: JICA Study Team)

Table-4.3.2.1-5 shows a list of selected species applying these assessment criterion. © marks main species, ○ are those species that would be planted with a proportion of 30% to 50%. This proportion is considered to avoid irreversible damages such as plagues that can kill all the trees.

Table 4.3.2.1-5 Selection of forest species

Watershed	Forest species
Chincha	Eucalipto (☉), Huarango (○), Casuarina (○)

In the Chincha Watershed the main forestry specie is Eucalyptus. This specie adapts very well in this area, it adapts to the zone and has high demand by the Water User's Committees. Huarango (*Prosopis limensis*: is how this plant is known in the northern region of Peru, comes from another seed) is a native specie form the southern region of Peru. It is planted along the Panamericana Highway. Casuarina specie has been planted in this area to protect from wind and sand, moreover for the lands near farms.

3) Quantity of reforestation plan

The forestry plan has been selected as it is mentioned in the location and type of species plan, in the bank protection and embankment wells along the riverside.

Following Table 4.3.2.1-3 shows the construction estimating for the Forestry and Recovery of Vegetation Cover Plan for Chincha Watershed.

Table 4.3.2.1-6 Amount of afforestation/vegetation recovery plan (riparian afforestation)

No.	Side	Length (m)	Width (m)	Forestation Area (ha)	No. of Planting Stocks (No.)	Number of planting stocks for each Species (No.)			
						Eucalyptus	Hurango	Casuarina	Total
Chico-1	Both	2,100	22	4.6	13,616	6,808	4,085	2,723	13,616
Chico-2				0.0	0	—	—	—	—
Chico-3				0.0	0	—	—	—	—
Ma-4	Both	2,500	22	5.5	16,280	8,140	4,884	3,256	16,280
Ma-5				0.0	0	—	—	—	—
Total Chincha		4,600		10.1	29,896	14,948	8,969	5,979	29,896

(Source: JICA Study Team)

In Table 4.3.2.1-7 shows the percentage according to forest species and the explanation in each bank structure.

Table 4.3.2.1-7 Ratios of number of planting stocks by species for each construction

Serial No.	No.	Ratio of No. by Species			Remarks
		Eucalyptus	Casuarina	Huarango	
12	Chico-1	5	2	3	Eucalyptus is main species, and Hurango is sub. Huarango is the native species, it is expected that its characteristics has much adequateness than Casuarina. Then, Huarango is planted with prior than Casuarina
15	Ma-4	5	2	3	

(Source: JICA Study team)

4) Plan location and execution

The location of the vegetation recovery area and afforestation plan for every bank structure is the

same. It is worth mentioning that the vegetation recovery area and afforestation plan will take place once finished the construction of bank structures.

(4) Reforestation and vegetation recovery plan cost (short term)

1) Unitary cost for the forestation plan and vegetation recovery

Direct costs for the forestation plan and vegetation recovery are formed by the following elements:

- Planting unitary cost (planting unitary cost + transportation)
- Labor cost
- Direct costs (tool costs: 5% labor)

a) Planting unitary cost

The supply of seedlings can be divided between private and agro-rural companies. The seedlings for afforestation upstream of the Chincha river watershed is acquired by AFRORURAL, in the case of plants for the river banks private companies will be the providers. The cost of plants for afforestation is detailed in Table 4.3.2.1-8. The price of different plants has been consulted in different private companies, just as with the means of transportation. (For more information see Appendix 7-Table 2)

Table 4.3.2.1-8 Unit price of seedling (for riparian forestation)

River Basin	Species	Unit Price (Sol./seedling)
Chincha,	Eucalyptus	1.4
	Huarango	1.8
	Casuarina	2.2

Note: Unit price of seedling = (Seedling price + transportation fee)

(Source: Hearing from suppliers)

b) Labor cost

Criteria to assign labor costs come from the information obtained from AGRORURAL and the Water users board, cost assigned by forestation of 40 seedling a day. So, 33.6 Soles/man-day is assigned for the workers foresting in river banks.

c) Direct costs

In direct costs the costs of the required tools are considered for the forestation project, instruments to dig holes for plants, plant transportation from its reception to the project area. Planting costs increase in 5%

d) Work cost calculation for forestation and vegetation recovery in bank structures

The work costs for the forestry plan and vegetation recovery in bank structures are indicated in Table 4.3.2.1-9. The total work cost is 144,148 soles.

To carry out the afforestation the contractor is needed to execute bank works. Just like the cost of construction works, 88% of direct costs is destined to indirect costs.

Table 4.3.2.1-9 Cost estimation of afforestation along river protection constructions (riparian afforestation)

No.	No. of Construction	Cost of Afforestation (Sol)					
		Direct Cost				Indirect Cost	Total
		Seedlings	Planting works	Direct Expense	Sub Total		
12	Chico-1	22,875	11,437	572	34,884	30,768	65,652
13	Chico-2				0	0	0
14	Chico-3				0	0	0
15	Ma-4	27,350	13,675	684	41,709	36,787	78,496
16	Ma-5				0	0	0
Chincha River Basin		50,225	25,113	1,256	76,594	67,555	144,148

Source: JICA Study Team)

(5) Implementation process planning

The Process Plan of afforestation works in riverbanks is part of the river structure, thus the same will be considered for the Construction Plan of the River Structure. Afforestation works should generally start at the beginning of the rainy season or just before, and must end approximately one month before the season finishes. However, there is scarce rain in the coastal area; therefore there is no effect of dry and rainy seasons. For the sake of afforestation, it is most convenient is to take advantage of water rise, but according to the Construction Schedule of the river structure there are no major afforestation issues in seasons where water level is low. The simple gravity irrigation system can be used to irrigate just planted plants during approximately the first 3 months until water level rises. This irrigation is performed using perforated hose which is a field technique actually carried out in Poechos dam area

4.3.2.2 Sediment Control Plan

(1) Importance of the sediment control plan

Below flood control issues in selected Watersheds are listed. Some of them relate to sediment control. In the present Project an overall flood control plan covering both the high and the low Watershed is prepared. The study for the preparation of the Sediment Control Plan comprised the whole Watershed.

- Water rise causes overflow and floods.
- Rivers have a steep slope of 1/30 to 1/300. The flow speed is high, as well as the sediment transport capacity.
- The accumulation of large quantities of dragged sediment and the consequent elevation of the river bed aggravate flood damages.
- There is a great quantity of sediment accumulated on the river bed forming a double sandbank. The water route and the spot of greater water impact are unstable, causing route change and consequently, change of spot of greater water impact.
- Riverside is highly erodible, causing a decrease of adjacent farming lands, destruction of regional roads, etc., for what they should be duly protected.
- Big stones and rocks cause damages and destruction of water intakes.

(2) Sediment control plan (structural measures)

The sediment control plan suitable for the present sediment movement pattern was analyzed. Table 4.3.2.2-1 details basic guidelines.

Table 4.3.2.2-1 Basic guidelines of the sediment control plan

Conditions	Typical year	Precipitations with 50-year return period
Sediment dragging	Bank erosion and river bed change	Bank erosion and river bed change Sediment flow from ravines
Measures	Erosion control → Bank protection Control of riverbed variation → compaction of ground, bands (compaction of ground in the alluvial cone, bands)	Erosion control → bank protection Riverbed variation control → compaction of ground, bands (compaction of ground in the alluvial cone, bands) Sediment flow → protection of slopes, sediment control dams

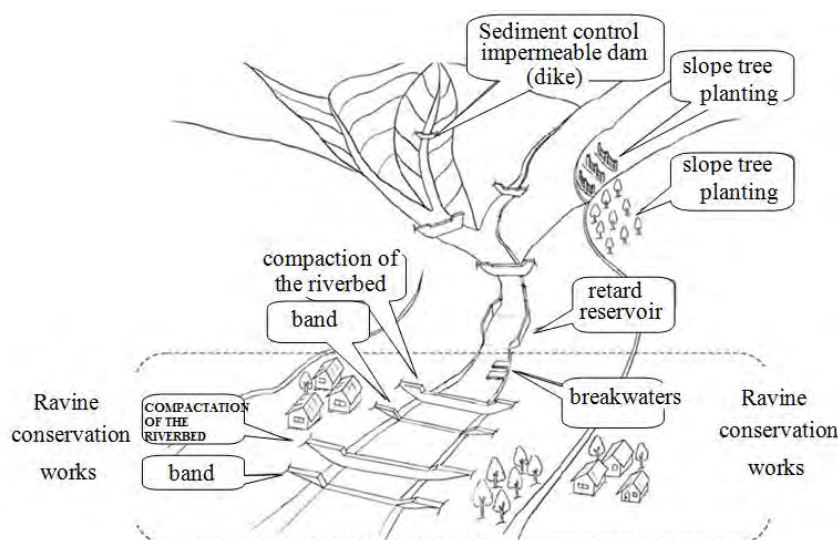

Figure 4.3.2.2-1 Sediment control works

1) Sediment control plan in the high watershed

The next section 4.15 “Medium and long term Plan” 4.15.3 “Sediment Control Plan” details the sediment control plan covering the whole high Watershed. This plan will require an extremely long time with huge costs, what makes it quite not feasible. Therefore, it must be executed progressively within the medium and long term.

2) Sediment control plan in the low watershed

We observed that building sediment control dams covering the whole Watershed will demand huge costs. Therefore, the same calculation was done but reducing its scope to just the lower Watershed of the river. In this process, analysis results on riverbed variation were taken into consideration, also

included in the present study.

i) Bed variation analysis results

- The analysis results of river bed fluctuation are described below. The average riverbed raising shows the average of raising in the objective section in future 50 years. The average bed height has been increasing, so basically it is concluded that this is the general trend.

Total sediment inflow	5,759,000 m ³
Average annual sediment inflow	115,000m ³
Total riverbed fluctuation volume	2,610,000m ³
Average Riverbed fluctuation height	0.5m/ 50 years

- The Chincha river is susceptible to the accumulation of sediment. This tendency coincides to the field hearing results and actual riverbed conditions.
- According to the results of the analysis of variation of the river bed, Chincha river is more susceptible to the accumulation of sediments carried, so sediment control works must be done in their respective alluvial fan. However the sediment disaster will happen suddenly and locally so that the required river channel maintenance work will be examined for all rivers with monitoring of river bed sedimentation.

While the variation of the bed (volume of sediment) is great too, looking at the average height of the bed, only 0.5 meters has changed in 50 years, and is therefore considered that the entry of sediments won't affect much the river downstream. Therefore, it is considered that it is not necessary to take a special sediment control measure.

ii) Sediment control plan in the alluvial fan

To control sediments within this fan there are ravine conservation works, combined with sand reservoirs, riverbed consolidation, groin or a combination of these. These do not only work for sediment control, but as river structures.

It is also planned to build a diversion weir in Chincha River. This includes stabilizing of the flow and training longitudinal dyke which serve to control the sediments.

These structures are more economical and yield better cost benefit compared with structures designed to cover the entire watershed. It is much more profitable even when the cost of maintenance includes removal of stones and rocks.

Whereas the main objective of this project is in mitigating flood damage, the most effective option would be to control sediment in the alluvial fan.

It is already being planned to build river structures which also serve to control sediment in rivers Chincha and Pisco, and its implementation would be the most effective also for this project.

4.3.3 Technical Assistance

Based on the proposals on flood control measures, a component on technical assistance is proposed in order to strengthen risk management capabilities in the Program.

(2) Component objective

The component objective in the Program is the “Adequate capability of local population and professionals in risk management application to reduce flood damages in Watersheds”.

(3) Target area

The target area for the implementation of the present component is the Chincha watershed.

In the execution stage, the implementation has to be coordinated with local authorities in the watershed. However, each authority has to execute those activities related with the characteristics of the watershed to carry out an adequate implementation.

(4) Target population

Target populations will represent irrigator associations and other community groups, provincial, district and local community governments and local people in the watershed, considering the limited capacity to receive beneficiaries of this component.

Participants are those with skills to widespread technical assistance contents of local populations in the watershed.

Besides, the participation of women has to be considered because currently only few ones participate in technical assistance opportunities.

(5) Activities

In order to achieve the above purpose, the following 3 components of study and training is to be carried out.

Component 1: Knowledge on River Bank Protection Actions in consideration of Agriculture and Natural Environment

Course	a) River Bank Operation and Maintenance b) River Bank Plant Management c) Erosion Prevention and Mitigation Natural Resource Management
Objectives	a) In this project, local populations learn suitable technology to operate and give maintenance to constructions and works from prior projects. b) Local populations learn suitable technology on river bank plants and vegetation for flooding control purposes. c) Local populations learn suitable technology on erosion and natural resources for flooding control purposes.
Participants	a) Engineers and / or technicians from local Governments b-c) Engineers and / or technicians from local Governments and Water Users Associations, Community representatives
Times	a) 12 times in all (every six (6) hours) b) 12 times in all (every five (5) hours) c) 26 times in all (every three (3) hours)
Lecturers	a) Contractors of constructions and works, Engineers from MINAG and / or the Regional Government b-c) Engineers from MINAG and / or the Regional Government,

	College professors (From universities, institutes, NGOs, etc.)
Contents	<ul style="list-style-type: none"> a-1) Suitable operation and maintenance technology for constructions and works from prior projects a-2) Suitable operation and maintenance technology for constructions and works in this project b-1) River bank protection with the use of plants b-2) The importance of river bank vegetation in flooding control b-3) Types of river bank plants and their characteristics c-1) Evaluation of the erosion conditions c-2) Evaluation of natural resource conditions <ul style="list-style-type: none"> c-3) Erosion approach for flooding control c-4) Natural resource approach for flooding control c-5) Environmental consideration approach <ul style="list-style-type: none"> c-6) Use of water resources c-7) Alternatives for suitable farming crops

Component 2: Preparation of Community Disaster Management Plan for Flood Control

Course	<ul style="list-style-type: none"> a) Risk management Plan Formulation b) Detailed Risk management Plan Formulation
Objectives	<ul style="list-style-type: none"> a) Local populations gain knowledge and learn technology to prepare a flooding control plan b) Ditto
Participants	a-c) Engineers and / or technicians from local Governments and Water Users Associations, Community representatives
Times	<ul style="list-style-type: none"> a) 19 times in all (every four (4) hours) b) 34 times in all (every five (5) hours) c) 24 times in all (every five (5) hours)
Lecturers	a-c) Engineers from MINAG and / or the Regional Government, Community Development Expert, Facilitator (local participation)
Contents	<ul style="list-style-type: none"> a-1) Flooding control plan preparation manuals a-2) Current condition analyses for flooding control a-3) Community development alternatives by means of local participation a-4) Workshop for flooding control plan preparation b-1) Community activity planning in consideration of ecological zoning b-2) Risk management b-3) Resource management c-1) Preparation of community disaster management plan c-2) Joint activity with local governments, users' association, etc.

Component 3: Basin Management for Anti – River Sedimentation Measures

Courses	<ul style="list-style-type: none"> a) Hillside Conservation Techniques b) Forest Seedling Production c) Forest Seedling Planting d) Forest Resource Management and Conservation
Objectives	<ul style="list-style-type: none"> a) Local populations learn suitable technology on hillside conservation for flooding control purposes b) Local populations learn suitable technology on forest seedling production c) Local populations learn suitable technology on forest seedling planting d) Local populations learn suitable technology on forest resource management and conservation
Participants	a-d) Engineers and / or technicians from local Governments and Water Users Associations, Community representatives and Local People

Times	a) 12 times in all (every five (5) hours) b-d) 40 times in all for three (3) “Courses on Basin Management for Anti - River Sedimentation Measures” (every five (5) hours)
Lecturers	a-d) Engineers from MINAG and / or the Regional Government, College professors (From universities, institutes, NGOs, etc.)
Contents	<ul style="list-style-type: none"> a-1) Soil characteristics and conservation on hillsides a-2) Hillside agroforestry system a-3) Animal herding system on hillsides a-4) Reforestation with traditional vegetation and plants a-5) Hillside conservation and alleviation alternatives b-1) A selection of plants that are suitable to the local characteristics <ul style="list-style-type: none"> b-2) Forest seedling production technology b-3) Control carried out by the local population’s involvement c-1) Candidate areas for forestation c-2) Forest plantation control technology c-3) Forest plantation soil technology c-4) Control carried out by the local population’s involvement <ul style="list-style-type: none"> d-1) Forestation for flooding control purposes d-2) Forest plantation control technology d-3) Forest plantation output technology d-4) Control carried out by the local population’s involvement

(6) Direct cost and period

The direct cost for the above activities is as shown in the Table 4.3.3-1. The total cost for the objective basin is estimated as 144,050 soles, and the brake down of the unit cost is as shown in the Annex-12, Appendix No.5. And the period required for study and training is assumed to be as same as the construction period of 2 years.

Table 4.3.3-1 Contents of technical assistance and direct cost

Item	Activities	Unit	Unit price(soles)	No.of basin	Amount(soles)
1.0	Knowledge on river bank protection action in consideration of agriculture and natural environment				
1.1	Workshop on operation and maintenance of facilities	event	9,300	1	9,300
1.2	Workshop on river bank plantation management	event	9,300	1	9,300
	Prevention and mitigation for erosion	event	9,300	1	9,300
	Natural resources management	event	9,300	1	9,300
2.0	Preparation of community disaster management plan for flood control				
2.1	Workshop on risk management plan	event	8,370	1	8,370
2.2	Details of 2.1	event			
	Community activity planning in consideration of ecological zoning	event	12,200	1	12,200
	Risk management	event	12,200	1	12,200
	Resource management	event	12,200	1	12,200
	Preparation of community disaster management plan	event	12,200	1	12,200
2.3	Preliminary flood forecasting and warning	event			
	Risk management and early warning system	event	9,300	1	9,300
	Joint activity with local government, users' association, etc.	event	5,580	1	5,580
3.0	Hillside management for river sedimentation prevention				
3.1	Field works for hillside conservation technique	event	7,500	1	7,500
	Forest seedling productions	event	7,900	1	7,900
	Forest plantation setting up	event	7,900	1	7,900
	Forest resource management and conservation		7,900	1	7,900
3.2	Difusion of posters and leaflet		3,600	1	3,600
	Total				144,050

(7) Implementation plan

The Hydraulic Infrastructure General Direction (DGIH-MINAG) executes this component as the executing unity in cooperation with the Agriculture Regional Direction (DRA), the Board of Users and related Institutions. In order to execute the activities efficiently the following has to be considered:

- For the implementation of the present component, the DGIH-MINAG will coordinate actions with the Central Management Unit responsible for each Watershed, as well as with Regional Managements of Agriculture (DRA).
- For the Project administration and management, the DGIH-MINAG will coordinate actions with PSI-MINAG (Sub-sector Irrigation Program with extensive experience in similar projects).
- Considering there are some local governments that have initiated the preparation of a similar crisis management plan through the corresponding civil defense committee, under the advice of the National Institute of Civil Defense (INDECI) and local governments, the DGIH-MINAG must coordinate so that these plans be consistent with those existing in each Watershed.

- Training courses will be managed and administered by irrigator associations (particularly the unit of skills development and communications) with the support of local governments in each Watershed, to support timely development in each town.
- Experts in disaster management departments in each provincial government, ANA, AGRORURAL, INDECI, etc., as well as (international and local) consultants will be in charge of course instruction and facilitation.

4.4 Costs

4.4.1 Cost Estimate (at Private Prices)

(1) Project Costs Components

Project cost is composed of the following components:

1) Infrastructure cost

i) Construction work cost

① Work direct costs (including plantation cost, environmental work cost, disaster prevention education/capacity development cost, infrastructure rehabilitation cost)

② Overhead cost = ① x 15%

③ Profit = ① x 10%

④ Work cost = ① + ② + ③

⑤ Tax = ④ x 18% (IGV)

⑥ Construction cost = ④ + ⑤

ii) Consultant cost (for structure, plantation, environmental work and disaster prevention education/capacity development)

⑦ Detailed design cost

⑧ Construction supervision cost

⑨ Consultant cost = ⑦ + ⑧

iii) Infrastructure cost = ⑥ + ⑨

2) Land acquisition cost

3) Management cost of implementation agency

4) Total project cost = 1) + 2) + 3)

(2) Direct cost

The direct costs were calculated by multiplying the unit prices with the work quantities. And the unit price is estimated for each work item based on the labor cost, material cost and equipment cost,

1) Labor cost

The labor costs in Chincha river are as shown in the Table-4.4.1-1.

2) Material cost

The major material costs in Chincha river are as shown in the Table-4.4.1-2.

3) Equipment cost

The rental costs of equipment in Chincha river are as shown in the Table-4.4.1-3 .

4) Work quantities

The work quantity of each work item in each flood prevention facility is as shown in the Table-4.4.1-4. For further detail of work quantities refer to Annex-8 Plan and Design of Facility.

5) Unit price of work

Based on the above costs the unit price of each work is estimated, of which results in in Cañete river are as shown in the Table--4.4.1-5. For further detail refer to Annex-9 Construction Planning and Cost Estimate. Based on the work quantities and the unit price of work, the direct cost of construction work is calculated as shown in the Table-4.4.1-6

(3) Infrastructure cost

The infrastructure cost is as shown in the Table4.4.1-12, in which the breakdown of the detail design cost and construction supervision cost are as shown in the Table-4.4.1-7 and Table-4.4.1-8 respectively. The consultant cost was estimated based on the Terms of Reference attached to Annex-14 Implementation Program of Japanese Yen Loan Project as Appendix-1

(4) Land acquisition and infrastructure rehabilitation

The land acquisition coat and infrastructure rehabilitation cost are as shown in the Table-4.4.1-9 and the Table-4.4.1-10 respectively. For further detail refer to Annex-9 Construction Planning and Cost Estimate, 4. Compensation.

(5) Management cost of implementation agency

The management cost of implementation agency is as shown in the Table-4.4.1-11.

(6) Total project cost

The total project cost is calculated as shown in the Table-4.4.1-12.

(7) Operation and maintenance cost

The operation and maintenance cost after completion of the Project is estimated as shown in the Table-4.4.1-14 (refer to Annex-9 Constructoion Planning and Cost Estimation).

Table-4.4.1-1 Unit labor cost (1) (Chincha river)

(SOLES)

Items	Skilled Labor	Comm onLabor	AassitantL abor	ChiefLabor **
Basic Wages (RB)	45.50	39.50	35.30	52.33
Bonus of Construction Dept. (BUC)	14.56	11.85	10.59	16.74
Social Benefit by Law Skilled Labor→ 18.03% Common Labor→ 17.83% AssitantLabor→ .83%	53.70	46.54	41.59	61.76
Life Insurance ESSALUD - VIDA (S/. 5.00/month)	0.17	0.17	0.17	0.19
Work ware (2sets) -(2x90 / 303)	0.60	0.60	0.60	0.69
Transpotation Wages	7.20	7.20	7.20	8.28
Daily Wages (8 hours)	121.73	105.86	95.45	139.99
Hourly Wages	15.22	13.23	11.93	17.50

**) 15% increase of hourly wages of skilled labor

source: REVISTA DE LA CAMARA PERUANA DE LA CONSTRUCCION

Table-4.4.1-1 Unit labor cost (2)

	Description	Unit	Unit Price (soles)
1	Rock Driller Assistant	h	15.22
2	Surveyor	h	17.50
3	Chief Labor	h	17.50
4	Skilled Labor	h	15.22
5	Common Labor	h	13.23
6	AssitantLlabor	h	11.93
7	Blasting specialist	h	17.50
8	Rock Driller	h	17.50

Table-4.4.1-2 Unit price of main material

	Material	Unit	Unit Price (soles)
1	Nail for wood C/C 3"	KG	3.69
2	Nail for calamina 1 1/2"	KG	6.15
3	Dynamite 65%	KG	7.29
4	Plus bit	No.	36.91
5	Drill hammer 7/8" X 3in	No.	295.32
6	Drill hammer 7/8" X 5in	No.	319.93
7	Plaster (28kg/sack)	sack	6.56
8	Train of powder	M	0.33
9	Primer	M	0.62
10	Installation of construction notice board	set	820.32
11	Wood 2" x 3" x 2.4M	No.	6.56
12	Control panel 4MM	sheet	30.16
13	Wooden pile	No.	1.64
14	Enamel paint	gallon	30.35
15	Galvanized roof sheet 1.83 x 0.90 x 0.3 mm	sheet	9.02
16	Anfo explosive	sack	57.75
17	Scale	No.	41.02
18	Fuel DIESEL N° 02	gallon	12.3
19	GEOTEXTILE	M2	5.2

Table-4.4.1-3 Unit cost of main heavy equipment

	Equipment	Unit	Unit Price(soles)
1	Compressor 335-375 PCM, 93 HP	h	98.44
2	Braker21 KG	h	20.51
3	Semi-trailer 6x4, 260-300 HP	L.S	10504.1
4	Staff&Pole	h	1.64
5	Water supply car 4 x 2(ASF) 178-210HP 2,000G	h	106.64
6	Theodlite	h	6.56
7	TractorS/O HP / D155X5	h	270.71
8	Back-hoe 158 HP / PC220	h	127.15
9	Dump truck 6X4 / 318 - 395 HP / 10 - 12 M3	h	110.74
10	Total station	h	13.14
11	Bulldozer 160-195 HP 3.5 YD3	h	159.66

Table-4.4.1-4 Work quantities

	Work	Unit	Quantities
			CHINCHA
1.0	Temporary work		

1.1	Field office	M2	530
1.2	Construction notice board	L.S.	5
1.3	Temporary road	KM	9
1.4	Equipment transportation	L.S.	
2.0	Preparatory work 準備工事		
2.1	Coordinates and leveling survey	M	23,774
2.2	Supervision of survey	M	13,201
2.3	Equipment transportation	L.S.	5
2.4	Removal of existing concrete	M3	1,035
2.5	Riverbed excavation	M3	139,745
2.6	Soil disposal	M3	107,913
3.0	Earth work		
3.1	Riverbed excavation	M3	174,085
3.2	-ditto-	M3	14,088
3.3	Banking and compaction	M3	218,234
3.4	Ripper excavation	M3	135,808
3.5	Finishing slope of dike	M3	47,848
3.6	Soil disposal	M2	147,710
3.7	Riverbed excavation(for structure)	M3	10,130
4.0	Bank protection		
4.1	Quarry of rock with blasting	M3	146,821
4.2	Accumulation of boulders	M3	146,821
4.3	Transportation of boulders	M3	146,821
4.4	Rivetment	M3	31,384
4.5	Installation of boulders	M3	116,087
4.6	Supply and installation of GEOTEXTILE sheet	M2	109,283
5.0	Concrete work		
5.1	Form work	M2	6,318
5.2	Concrete placing (FC=210 KG/CM2)	M3	9,418
6.0	Gabion work		
6.1	Accumulation of crushed stone (6~8 インチ)	M3	3,900
6.2	Transportation of crushed stone	M3	3,900
6.3	Installation of mattress basket(5.0x1.0x1.0)m	No.	780
6.4	Putting crushed stone into basket(5.0x1.0x1.0)m	M3	3,900
6.5	Covering basket(5.0x1.0x1.0)m	No.	780

Table-4.4.1-5 Estimate of work unit cost (example of Cañete river: Ca-1)

Work	Temprary field office					
Rate	20 M2/DIA (m2/day)				Unit cost per : M2	85.73
Code	Discription	Unit	Party	Quantities	Unit price	Sub total
Labor cost						
470101	Chief Labor	h	0.10	0.04	17.50	0.70
470102	Skilled Labor	h	1.00	0.40	15.22	6.09
470103	Common Labor	h	1.00	0.40	13.23	5.29
470104	Assistant Labor	h	3.00	1.20	11.93	14.32
						26.40
Material cost						
020105	Nail for woodC/C 3"	KG		0.30	3.69	1.11
020112	Nail for calamina 1 1/2"	KG		0.22	6.15	1.35
430101	Wood 2" x 3" x 2.4M	No.		4.00	6.56	26.24
430201	Control panel 4MM	sheet		0.75	30.16	22.62
560101	Galvanized roof sheet 1.83 x 0.90 x 0.3 mm	sheet		0.80	9.02	7.22
						58.54
Equipment cost						
370101	Hand tool	%		3.00	26.40	0.79
						0.79

Work	Construction notice board					
Rate	3 (units/day)				Unit cost per unit	922.20
Code	Discription	Unit	Party	Quantities	Unit price	Sub total
Labor cost						
470103	Common Labor	h	1.00	2.67	13.23	35.28
470104	Assistant Labor	h	2.00	5.33	11.93	63.63
						98.91
Material cost						
399095	Transportation & installation of notice board	unit		1.00	820.32	820.32
						820.32
Equipment cost						
370101	Hand tool	%		3.00	98.91	2.97
						2.97

Work	Temporary road					
Rate	0.9 (Km/day)				Unit cost per KM	4,215.51
Code	Discription	Unit	Party	Quantities	Unit price	Sub total
Labor cost						
470101	Chief Labor	h	0.20	1.78	17.50	31.11
470103	Common Labor	h	1.00	8.89	13.23	117.60

*Preparatory study about the protection program for
valleys and rural communities vulnerable to floods in Peru
Final Report I-3 Main Report Project Report (Chincha River)*

470104	Assistant Labor	h	1.00	8.89	11.93	106.04
						254.75
	Material cost					
910101	Fuel DIESEL N° 02	gallon		106.49	12.30	1,309.83
						1,309.83
	Equipment cost					
370101	Hand tool	%		3.00	254.75	7.64
490101	Water supply car 4 x 2(ASF) 178-210HP 2,000G	h	0.25	2.22	106.64	236.98
499401	Tractor S/O HP / D155X5	h	1.00	8.89	270.71	2,406.31
						2,650.93
Work	Coordinates & Levelling survey					
Rate	500 (m/day)			Unit cost per M	1.15	
Code	Discription	Unit	Party	Quantities	Unit price	Sub total
	Labor cost					
470032	Surveyor	h	1.00	0.02	17.50	0.28
470104	Assistant Labor	h	3.00	0.05	11.93	0.57
						0.85
	Material cost					
300201	Plaster (28kg/sack)	sack		0.01	6.56	0.03
540242	Enamel paint	gallon		0.00	30.35	0.03
						0.06
	Equipment cost					
370101	Hand tool	%		3.00	0.85	0.03
499701	Total station	h	1.00	0.02	13.14	0.21
						0.24
Work	Supervision of survey					
Rate	300 (m/day)			Unit cost per M	1.79	
Code	Discription	Unit	Party	Quantities	Unit price	Sub total
	Labor cost					
470032	Surveyor	h	1.00	0.03	17.50	0.47
470104	Assistant Labor	h	2.00	0.05	11.93	0.64
						1.11
	Material cost					
300201	Plaster (28kg/sack)	sack		0.00	6.56	0.02
439901	Wooden peg	No.		0.20	1.64	0.33
900101	Scale	No.		0.00	41.02	0.08
						0.43
	Equipment cost					
370101	Hand tool	%		3.00	1.11	0.03
375401	Staff& pole	h	1.00	0.03	1.64	0.04
491901	Theodolite	h	1.00	0.03	6.56	0.18
						0.25

*Preparatory study about the protection program for
valleys and rural communities vulnerable to floods in Peru
Final Report I-3 Main Report Project Report (Chincha River)*

Work	Transportation of heavy equipment					
Rate	1 (set/day)			Unit cost per set	10,504.11	
Code	Discription	Unit	Party	Quantities	Unit price	Sub total
	Equipment cost					
320201	Semi-trailer 6x4, 260-300 HP	set	1.00	1.00	10,504.11	10,504.11
						10,504.11
Work	Riverbed excavation					
Rate	800 (m3/day)			Unit cost per M3	4.18	
Code	Discription	Unit	Party	Quantities	Unit price	Sub total
	Labor cost					
470101	Chief Labor	h	0.20	0.00	17.50	0.04
470103	Common Labor	h	1.00	0.01	13.23	0.13
						0.17
	Material cost					
910101	Fuel DIESEL N° 02	gallon		0.11	12.30	1.29
						1.29
	Equipment cost					
370101	Hand tool	%		3.00	0.17	0.01
499401	Tractor S/O HP / D155X5	h	1.00	0.01	270.71	2.71
						2.72
Work	Transportation of back-fill soil					
Rate	1,100 (m3/day)			Unit cost per M3	6.05	
Code	Discription	Unit	Party	Quantities	Unit price	Sub total
	Labor cost					
470101	Chief Labor	h	0.20	0.00	17.50	0.03
470103	Common Labor	h	1.00	0.01	13.23	0.10
						0.13
	Material cost					
910101	Fuel DIESEL N° 02	gallon		0.14	12.30	1.77
						1.77
	Equipment cost					
370101	Hand tool	%		3.00	0.13	0.00
499501	Hand tool	h	1.00	0.01	127.15	0.93
499601	Dump truck 6X4 / 318 - 395 HP / 10 - 12 M3	h	4.00	0.03	110.74	3.22
						4.15
Work	Banking & compaction					
Rate	900 (m3/day)			Unit cost per	3.71	

*Preparatory study about the protection program for
valleys and rural communities vulnerable to floods in Peru
Final Report I-3 Main Report Project Report (Chincha River)*

M3						
Code	Discription	Unit	Party	Quantities	Unit price	Sub total
Labor cost						
470101	Chief Labor	h	0.20	0.00	17.50	0.03
470103	Common Labor	h	1.00	0.01	13.23	0.12
						0.15
Material cost						
910101	Fuel DIESEL N° 02	gallon		0.09	12.30	1.15
						1.15
Equipment cost						
370101	Hand tool	%		3.00	0.15	0.00
499401	Tractor S/O HP / D155X5	h	1.00	0.01	270.71	2.41
						2.41
Work	Ripper excavation				Unit cost per	
Rate	300 (m3/day)				M3	4.76
Code	Discription	Unit	Party	Quantities	Unit price	Sub total
Labor cost						
470101	Chief Labor	h	0.20	0.01	17.50	0.09
470103	Common Labor	h	1.00	0.03	13.23	0.35
						0.44
Material cost						
910101	Fuel DIESEL N° 02	gallon		0.07	12.30	0.92
						0.92
Equipment cost						
370101	Hand tool	%		3.00	0.44	0.01
499501	Back-hoe 158 HP / PC220	h	1.00	0.03	127.15	3.39
						3.40
Work	Finishing slope of dike				Unit cost per	
Rate	1,100 (m2/day)				M2	1.55
Code	Discription	Unit	Party	Quantities	Unit price	Sub total
Labor cost						
470101	Chief Labor	h	0.20	0.00	17.50	0.03
470103	Common Labor	h	1.00	0.01	13.23	0.10
						0.13
Material cost						
910101	Fuel DIESEL N° 02	gallon		0.04	12.30	0.49
						0.49
Equipment cost						
370101	Hand tool	%		3.00	0.13	0.00
499501	Back-hoe 158 HP / PC220	h	1.00	0.01	127.15	0.93
						0.93

*Preparatory study about the protection program for
valleys and rural communities vulnerable to floods in Peru
Final Report I-3 Main Report Project Report (Chincha River)*

Work	Quarry of rock by blasting				
Rate	90 (m3/day)		Unit cost per M3	27.49	

Code	Discription	Unit	Party	Quantities	Unit price	Sub total
Labor cost						
010101	Skilled Labor	h	2.00	0.18	15.22	2.71
470101	Chief Labor	h	0.20	0.02	17.50	0.31
470103	Common Labor	h	1.00	0.09	13.23	1.18
470104	Assistant Labor	h	1.00	0.09	11.93	1.06
470105	Blasting Specialist	h	1.00	0.09	17.50	1.56
980101	Rock Driller	h	2.00	0.18	17.50	3.11
						9.93
Material cost						
070101	Dynamite · 65%	KG		0.12	7.29	0.85
080101	Plus bit	No.		0.01	36.91	0.18
090101	Dril hammer7/8" X 3in	No.		0.00	295.32	0.35
100101	Drill hammer7/8" X 5in	No.		0.00	319.93	0.38
308601	Train of powder	M		0.89	0.33	0.29
308602	Primer	M		0.31	0.62	0.19
790101	Anfo explosive	sack		0.00	57.75	0.11
910101	Fuel DIESEL N° 02	gallon		0.20	12.30	2.51
						4.86
Equipment cost						
110101	Compressor 335-375 PCM, 93 HP	h	1.00	0.09	98.44	8.75
120101	Braker21 KG	h	2.00	0.18	20.51	3.65
370101	Hand tool	%		3.00	9.93	0.30
						12.70

Work	Accumulation of boulders				
Rate	100 (m3/day)		Unit cost per M3	15.65	

Code	Discription	Unit	Party	Quantities	Unit price	Sub total
Labor cost						
470101	Chief Labor	h	0.20	0.02	17.50	0.28
470103	Common Labor	h	1.00	0.08	13.23	1.06
						1.34
Material cost						
910101	Fuel DIESEL N° 02	gallon		0.33	12.30	4.10
						4.10
Equipment cost						
370101	Hand tool	%		3.00	1.34	0.04
499501	Back-hoe158 HP / PC220	h	1.00	0.08	127.15	10.17
						10.21

Work	Transportation of boulders				
Rate	220 (m3/day)		Unit cost per M3	48.17	

*Preparatory study about the protection program for
valleys and rural communities vulnerable to floods in Peru
Final Report I-3 Main Report Project Report (Chincha River)*

Code	Discription	Unit	Party	Quantities	Unit price	Sub total
Labor cost						
470101	Chief Labor	h	0.20	0.01	17.50	0.13
470103	Common Labor	h	1.00	0.04	13.23	0.48
470104	Assistant Labor	h	1.00	0.04	11.93	0.43
						1.04
Material cost						
910101	Fuel DIESEL N° 02	gallon		1.82	12.30	22.34
						22.34
Equipment cost						
370101	Hand tool	%		3.00	1.04	0.03
499501	Back-hoe158 HP / PC220	h	1.00	0.04	127.15	4.63
499601	Dump truck6X4 / 318 - 395 HP / 10 - 12 M3	h	5.00	0.18	110.74	20.13
						24.79

Work	Revetment					
Rate	150 (m3/day)			Unit cost per M3	14.92	

Code	Discription	Unit	Party	Quantities	Unit price	Sub total
Labor cost						
470101	Chief Labor	h	0.20	0.01	17.50	0.19
470103	Common Labor	h	1.00	0.05	13.23	0.71
470104	Assistant Labor	h	6.00	0.32	11.93	3.82
						4.72
Material cost						
910101	Fuel DIESEL N° 02	gallon		0.27	12.30	3.28
						3.28
Equipment cost						
370101	Hand tool	%		3.00	4.72	0.14
499501	Back-hoe158 HP / PC220	h	1.00	0.05	127.15	6.78
						6.92

Work	Installation of boulders					
Rate	200 (m3/day)			Unit cost per M3	9.43	

Code	Discription	Unit	Party	Quantities	Unit price	Sub total
Labor cost						
470101	Chief Labor	h	0.50	0.02	17.50	0.35
470103	Common Labor	h	1.00	0.04	13.23	0.53
470104		h	2.00	0.08	11.93	0.95
						1.83
Material cost						
910101	Fuel DIESEL N° 02	gallon		0.20	12.30	2.46
						2.46
Equipment cost						
370101	Hand tool	%		3.00	1.83	0.05

*Preparatory study about the protection program for
valleys and rural communities vulnerable to floods in Peru
Final Report I-3 Main Report Project Report (Chincha River)*

499501	Back-hoe158 HP / PC220	h	1.00	0.04	127.15	5.09
						5.14
Work	Supply & installation of GEOTEXTILE					
Rate	600 (m2/day)			Unit cost per M2	6.00	
Code	Discription	Unit	Party	Quantities	Unit price	Sub total
	Labor cost					
470101	Chief Labor	h	0.10	0.00	17.50	0.02
470103	Common Labor	h	1.00	0.01	13.23	0.18
470104		h	2.00	0.03	11.93	0.32
						0.52
	Material cost					
940201	GEOTEXTILE	M2		1.05	5.20	5.46
						5.46
	Equipment cost					
370101	Hand tool	%		3.00	0.52	0.02
						0.02

Table-4.4.1-6 Direct cost(private price and social price)

SOLES

Basin	Name of Facility	Direct Cost 直接工事費計											
		River Structure		Plantation		Environmental Work		Disaster Prevention Education/Capacity Development		Rehabilitation of Existing Facility		Private Price 民間価格 (PP)	Social Price 社会価格 (PS)
		Private Price 民間価格 (PP)	Social Price 社会価格 (PS)	Private Price 民間価格 (PP)	Social Price 社会価格 (PS)	Private Price 民間価格 (PP)	Social Price 社会価格 (PS)	Private Price 民間価格 (PP)	Social Price 社会価格 (PS)				
Chincha	Chico-1	3,869,704	3,191,494	34,884	27,534								
	Chico-2	1,533,855	1,264,465										
	Chico-3	9,533,669	7,830,517										
	Ma-1	5,129,938	4,271,028	41,709	32,922						192,130	158,892	
	Ma-2	6,480,309	5,325,681								295,309	244,221	
	SUB TOTAL	26,547,476	21,883,183	76,593	60,456	798,096	676,353	144,050	124,788	487,440	403,113		

Table 4.4.1-7 Consultant cost for detail design stage(for 4 basins)

	Item	Unit	Qty	Foreign Portion		Local Portion		Combined Total
				(Yen)		(soles)		(yen)
				Rate	Amount ('000)	Rate	Amount ('000)	Amount ('000)
A	Remuneration							
	1 Professional (A)	M/M	44	2,500,000	110,000	0	0	110,000
	2 Professional (B)	M/M	70	0	0	10,000	700	19,670
	3 Supporting Staffs	M/M	312	0	0	4,000	1,248	35,069
	Subtotal of A				110,000		1,948	164,739
B	Direct Cost							
	1 International Airfare		17	1,057,200	17,972	0	0	17,972
	2 Domestic Airfare (Duty Trip)		16		0	1,096	18	493
	3 Domestic Travel				0	0	0	0
	4 Accommodation Allowance (Pro A)	Month	44		0	5,480	241	6,775
	(Pro.B)	Month	70		0	2,740	192	5,390
	5 Per Diem for Duty Trip	Day	48		0	137	7	185
	6 Vehicle Rental	Month	0		0	5,480	0	0
	7 Office Rental	M/M	3		0	274	1	23
	8 International Communications	M/M	16		0	2,740	44	1,232
	9 Domestic Communications	M/M	16		0	1,370	22	616
	10 Office Supply	M/M	16		0	548	9	246
	11 Office Furniture and Equipment	L.M	1		0	54,800	55	1,540
	12 Report Preparation					0		
	1) Detailed Design	Volume	12		0	55	1	18
	2) Bid Documents	Volume	16		0	55	1	25
	3) Monthly and Quaterly Progress R	Volume	28		0	55	2	43
	4) Completion Report	Volume	5		0	55	0	8
	5) Other Notes and Documents	Volume	10		0	55	1	15
	13 Sub-Contracting Work					0	0	0
	Topographic Survey	Site	4		0	137,000	548	15,399
	Geotechnical Investigation	Site	4		0	82,200	329	9,239
	Environmental Monitoring	Site	4		0	68,500	274	7,699
	14 Technical & PCM	time	4		0	8,220	33	924
	Subtotal of B				17,972		1,775	67,843
	A+B				127,972		3,723	232,582
	A+B (soles)							8,276,940
	C: VAT(18%)(soles)							1,489,849
	Total A+B+C(soles)							9,766,778

Table 4.4.1-8 Consultant Cost for Construction Supervision Stage (for 4 basins)

	Item	Unit	Qty	Foreign Portion		Local Portion		Combined Total
				(Yen)		(soles)		(yen)
				Rate	Amount ('000)	Rate	Amount ('000)	Amount ('000)
A	Remuneration							
1	Professional (A)	M/M	82	2,500,000	205,000	0	0	205,000
2	Professional (B)	M/M	135	0	0	10,000	1,350	37,935
3	Supporting Staffs	M/M	336	0	0	4,000	1,344	37,766
	Subtotal of A				205,000		2,694	280,701
B	Direct Cost							
1	International Airfare		8	1,057,200	8,458	0	0	8,458
2	Domestic Airfare (Duty Trip)		29		0	1,096	32	893
3	Domestic Travel		0		0	0	0	0
4	Accommodation Allowance (Pro A)	Month	82		0	5,480	449	12,627
	(Pro.B)	Month	135		0	2,740	370	10,394
5	Per Diem for Duty Trip	Day	87		0	137	12	335
6	Vehicle Rental	Month	159		0	5,480	871	24,484
7	Office Rental	M/M	138		0	274	38	1,063
8	International Communications	M/M	29		0	2,740	79	2,233
9	Domestic Communications	M/M	29		0	1,370	40	1,116
10	Office Supply	M/M	29		0	548	16	447
11	Office Furniture and Equipment	L.M	0		0	54,800	0	0
12	Report Preparation					0		
1)	Detailed Design	Volume	0		0	55	0	0
2)	Bid Documents	Volume	0		0	55	0	0
3)	Monthly and Quaterly Progress R	Volume	29		0	55	2	45
4)	Completion Report	Volume	0		0	55	0	0
5)	Other Notes and Documents	Volume	0		0	55	0	0
13	Sub-Contracting Work		0			0	0	0
	Topographic Survey	Site	0		0	137,000	0	0
	Geotechnical Investigation	Site	0		0	82,200	0	0
	Environmental Monitoring	Site	0		0	68,500	0	0
14	Technical & PCM	time	6		0	8,220	49	1,386
	Subtotal of B				8,458		1,958	63,480
	A+B				213,458		4,652	344,181
	A+B(soles)							12,248,434
	C: VAT(18%)(soles)							2,204,718
	Total A+B+C(soles)							14,453,162

Table 4.4.1-9 Land acquisition cost (soles)

Basin	Rural Area A	Rural Area B	Total
Chincha	79,110	542,289	621,399

Table 4.4.1-10 Rehabilitation cost of existing facility (direct cost)

Basin	Hydraulic Infrastructure			Road			Total
	Intake	Outlet	Channel	National	Departmental	Others	
Chincha	297,721	189,719	0	0	0	0	487,440

Table-4.4.1-11 Administration cost of implementation agency (for 4 basins)

	Item	Rate (US\$)	Rate (soles)	Period (month)	Total(soles)
A	Program Management Unit (PMU)				
1	Project Manager	6,000	16,320	36	587,520
2	Contact specialist	5,000	13,600	36	489,600
3	Secretary	1,200	3,264	36	117,504
4	Construction supervisor (Cañete river)	3,500	9,520	30	285,600
5	Construction supervisor (Chincha river)	3,500	9,520	30	285,600
6	Construction supervisor (Pisco river)	3,500	9,520	30	285,600
7	Construction supervisor (Majes-Camana river)	3,500	9,520	30	285,600
8	IT Engineer	2,750	7,480	36	269,280
9	Procurement specialist	3,300	8,976	36	323,136
10	Financial manager	3,300	8,976	36	323,136
11	Organization specialist (Adviser for irrigation committee)	3,300	8,976	36	323,136
12	Environmental assessment specialist	3,300	8,976	30	269,280
13	Archaeological specialist	3,300	8,976	30	269,280
14	Accountant	4,200	11,424	36	411,264
15	Driver ①	1,200	3,264	36	117,504
16	Driver ②	1,200	3,264	36	117,504
17	Driver ③	1,200	3,264	36	117,504
Subtotal					4,878,048
B	Audit Cost				
1	2012 year	25,000	68,000		68,000
2	2013 year	40,000	108,800		108,800
3	2014 year	40,000	108,800		108,800
4	2015 year	50,000	136,000		136,000
Subtotal					421,600
C	Capacity Building				
C1	For JICA Project				
1	Project manager	30	81.60	100	8,160
2	Contact specialist	30	81.60	100	8,160

*Preparatory study about the protection program for
valleys and rural communities vulnerable to floods in Peru
Final Report I-3 Main Report Project Report (Chincha River)*

3	Lawyer	30	81.60	100	8,160
4	Construction supervisor (Cañete river)	30	81.60	100	8,160
5	Construction supervisor (Chincha river)	30	81.60	100	8,160
6	Construction supervisor (Pisco river)	30	81.60	100	8,160
7	Construction supervisor (Majes-Camana river)	30	81.60	100	8,160
8	Miscellaneous procurement specialist	30	81.60	100	8,160
9	Accountant ①	30	81.60	100	8,160
10	Accountant ②	30	81.60	100	8,160
	Subtotal				81,600
C2 Capacity Building					
1	Project manager (management and finance)	10,000	27,200		27,200
2	Contract specialist(management and finance))	10,000	27,200		27,200
3	Lawyer	8,000	21,760		21,760
4	Construction supervisor (Cañete river)	8,000	21,760		21,760
5	Construction supervisor (Chincha river)	8,000	21,760		21,760
6	Construction supervisor (Pisco river)	8,000	21,760		21,760
7	Construction supervisor (Majes-Camana river)	8,000	21,760		21,760
8	IT engineer ①	8,000	21,760		21,760
9	IT engineer ②	8,000	21,760		21,760
10	Miscellaneous procurement specialist (contrac)	8,000	21,760		21,760
11	Accountant ① (accounting and finance)	8,000	21,760		21,760
12	Accountant ② (accounting and finance)	8,000	21,760		21,760
	Subtotal				272,000
D Procurement of Equipment					
1	Office funituturs	50,000	136,000	1	136,000
2	PC & copy maschine	35,000	95,200	1	95,200
3	Vhicle ① (4WD)	32,000	87,040	1	87,040
4	Vhicle ② (4WD)	32,000	87,040	1	87,040
5	Vhicle ③ (4WD)	32,000	87,040	1	87,040
6	Fuel & car maintenance	2,880	7,834	36	282,010
7	Office suply	1,000	2,720	36	97,920

*Preparatory study about the protection program for
valleys and rural communities vulnerable to floods in Peru
Final Report 1-3 Main Report Project Report (Chincha River)*

	Subtotal				872,250
E Monitoring of Project					
1	Administrator (project monitoring)	4,050	11,016	36	396,576
2	Engineer (project monitoring)	3,300	8,976	36	323,136
3	Consultant (organizing irrigation committee information & capacity building))	100,000	272,000	1	272,000
4	Consultant (preparation of completion report)	80,000	217,600	1	217,600
5	Air ticket	2,000	5,440	36	195,840
6	Per diem	6,000	16,320	36	587,520
	1,992,672				1,992,672
Total					8,518,170

Table-4.4.1-12 Total project cost (private price)

soles
SOLES

Name of Basin	Direct Cost					Indirect Cost					Consultant Cost			Infrastructure Cost Total Cost	Land Aquisition Cost	Cost Total for Basin	
	COMPONENT A				Direct Cost	Overhead	Profit	Work Cost	Tax(IGV)	Total Construction Cost	Detail Design Cost	Construction Supervision Cost	Total Construction Cost				
	Sutstructure Cost		Aforestation/ Reforestation	Environmental Cost													Disaster Prevention Education/ Capacity Development
	Flood Prevention Facility	Rehabilitation cost of Existing Structure															
(1)-1	(1)-2	(2)	(3)	(4)	(5)=(1)+(2)+(3)+(4)	(6) = 0.15 x (5)	(7) = 0.1 x (5)	(8) = (5)+(6)+(7)	(9) = 0.18 x (8)	(10) = (8)+(9)	(11)	(12)	(13)=(11)+(12)	(14)=(10)+(13)	(15)	(17)=(14)+(15)+(16)	
CHINCHA	26,547,476	487,440	76,593	798,096	144,050	28,053,654	4,208,048	2,805,365	35,067,068	6,312,072	41,379,140	2,025,254	2,997,030	5,022,284	46,401,424	622,981	47,024,405

soles

Table-4.4.1-13 Total project cost (social price)

SOLES

Name of Basin	Total Construction Cost (Private Price)	Factor of Correction	Total Construction Cost (Social Price)	Consultant Cost			Infrastructure Cost Total Cost	Land Acquisition Cost	Cost Total for Basin
				Detail Design Cost	Construction Supervision Cost	Total Construction Cost			
	(10) = (8)+(9)			(11)	(12)	(13)=(11)+(12)	(14) = (10)+(13)	(15)	(17) = (14)+(15)+(16)
CHINCHA	41,379,140	0.825	34,143,142	1,800,180	2,683,167	4,483,347	38,626,489	537,590	39,164,079

Table-4.4.1-14 Annual operation and maintenance cost

Basin	Cost(soles) (Private Price)	Ratio to Construction Cost (%)	Cost (soles) (Social Price)	Ratio to Construction Cost (%)
Chincha	434,894	1.1	370,955	1.1

4.4.2 Cost Estimate (at Social Price)

The direct cost at social price is as shown in the previous Table-4.4.1-6. The consultant cost, land acquisition cost and administration cost of the implementation agency are converted from the private price to the social price. The total project cost at social price is calculated as shown in the Table-4.4.1-13.

The social price is calculated by multiplying the private price (labor cost, material cost and equipment cost) with the standard conversion factor (SCF). SCF is the ratio of the private price in domestic and the social price calculated at the border with respect to all goods of the country's economy,

In this study, economic evaluation is calculated based on the Guidelines which are available in Peru (Guideline of the National Public Investment System (Directorial Resolution No. 003-2011-EF/68.01, Annex SNIP 10-V3.1)). Ministry of Economy and Finance is indicated SCF as shown in Table -4.4.2-1.

Table-4.4.2-1 Standard conversion factor (SCF)

Correction Factors for Social Rates (Methodology MEF)	
DESCRIPCION	VALOR
National Property Expenditures	0.85
Imported Goods Expenditures	0.92
Indirect Imported Goods Expenditures*	
Tasa Ad. Valorem	0.12
General Sales Tax Rate	0.18
Currency correction factor	1.08
Fuel costs	0.66
Indirect costs (administrative and financial)	0.85
Legal entity	0.85
Natural Person	0.91
Expenditures on skilled labor	0.91
Expenditures on non skilled labor	0.68
Lima Metropolitana urbano	0,86
Urban Coast Region	0,68
Rural Coast Region	0,57
Urban Sierra Region	0,60
Urban Sierra Region	0,41
Urban Forest Region	0,63
Rural Forest Region	0,49
Indirect taxes Manpower **	
Fourth Category Rate for Non-Personal Services (10%)	0.91

As an example, the process of conversion from private price to social price for the direct cost of river structures is as shown in the Table-4.4.2-2. For other costs the process is shown in the Annex-10 Socio-economy and Economic Evaluation, Attachment-3.

4.5 Social Assessment

4.5.1 Private Prices Costs

(1) Benefits

Flood control benefits are flood loss reduction that would be achieved by the implementation of the Project and is determined by the difference between the amount of loss with and without Project. Specifically, in order to determine the benefits that will be achieved by the works' construction. First, the flood amount per flood loss of the different return periods (between 2 to 50 years) is calculated; assuming that the flood control works have a useful life of 50 years. To finish, determine the annual average amount of the loss reduction from the loss amount of different return periods. [The Methodological Guideline for Protection and/or Flood Control Projects in agricultural or urban areas, 4.1.2p-105)] establishes similar procedures. Above find the description of the procedures to determine concrete benefits.

- ① Determine the flood loss amount in the flood area by analyzing the magnitude of overflow that occurs without the Project for each return period (between 2 and 50 years).
- ② After, determine the amount of flood loss in the flood area by analyzing the magnitude of overflow that occurs when flood control priority works are built.
- ③ Determine the difference between ① and ②. Add the benefits of other works different than dikes (intakes, roads protection, etc.) in order to determine the total profits.

“Benefits of the Project” are considered as the sum of direct loss amount caused by overflow and indirect loss caused by the destruction of structures in vulnerable sections (farmland loss, interruption of traffic, etc.)

1) Method of loss amount calculation

In this study, the amount of loss from direct and indirect damages to the variables listed in Table 4.5.1-1 was determined.

Table 4.5.1-1 Flood loss amount calculation variables

Loss	Variables	Description
(1) Direct	① Crops	<ul style="list-style-type: none"> • Crops in flooding season The amount of crop loss by flooding is determined by multiplying the damage % regarding water depth and the number of days flooded • Agricultural land and infrastructure (channels, etc.) • Crop loss amount is determined by multiplying the damage % regarding water depth and the number of days flooded
	② Hydraulic Works	<ul style="list-style-type: none"> • Loss amount due to hydraulic structures destruction (intakes, channels, etc.).
	③ Road Infrastructures	<ul style="list-style-type: none"> • Flood damage related to road infrastructure is determined by the damage in transport sector
	④ Housing	<ul style="list-style-type: none"> • Residential and industrial buildings It is calculated applying the loss coefficient depending on the flood depth

		Housing: residential and industrial buildings; household goods: furniture, household appliances, clothing, vehicles, etc. Flood damages in housing, commercial buildings, assets and inventories (buildings and assets) is determined applying the loss coefficient according to the flood depth
	⑤ Public Infrastructures	<ul style="list-style-type: none"> • Determine the loss amount in roads, bridges, sewers, urban infrastructures, schools, churches and other public facilities • Determine the loss amount in public works by applying the correspondent coefficient to the general assets loss amount
	⑥ Public Services	<ul style="list-style-type: none"> • Electricity, gas, water, rail, telephone, etc.
(2) Indirect	① Agriculture	<ul style="list-style-type: none"> • Estimate the loss caused by irrigation water interruption due to the damage of hydraulic structures • Determine the construction and repair costs of hydraulic structures such as direct year costs
	② Traffic Interruption	<ul style="list-style-type: none"> • Estimate the loss lead by traffic interruption due to damages on flooded roads • Determine road's repair and construction costs as damage direct cost

a) Direct loss

Direct loss is determined by multiplying the damage coefficient according to the inundation depth as the asset value.

b) Indirect Loss

Indirect loss is determined taking into account the impact of intakes and damaged roads. Below, calculation procedures are described.

i) Intake damage

The loss amount due to intake damage is calculated by adding the direct loss (intake's rehabilitation and construction) and the indirect loss amount (harvest loss due to the interruption of irrigation water supply)

① Calculating the infrastructure cost

Works Cost = construction cost per water unit taken × size (flow, work length)

Unit cost of the work: for intakes and channels, it is required to gather information on the water intake volume of the existing work and the works' execution cost (construction or repair). The unit cost is calculated by analyzing the correlation among them both.

It was estimated that the work will be completely destroyed by the flow with a return period of 10 years.

② Crop loss

Annual earnings are determined according to the crops grown in the correspondent irrigation district.

Annual Profit = (crops selling - cost) × frequency of annual harvest

Crop Sale = planted area (ha) x yield (kg/ha) × transaction unit price

Cost = unit cost (s/ha) × planted area (ha)

ii) Road infrastructure damage

Determine the loss due to traffic interruption.

Amount of loss = direct loss + indirect loss

Direct loss: road construction cost (construction, rehabilitation)

Indirect Loss: opportunity loss cost due to road damage (vehicle depreciation + staff expenses loss)

Then, a 5 days period takes place of non-trafficability (usually in Peru it takes five days to complete the rehabilitation of a temporary road)

2) Loss estimated amount according to different return periods

The loss amount according to the different return periods is calculated as shown in the Table 4.5.1-2.

For further detail refer to I-7 Data Book.

Table 4.5.1-2 Esimated loss by flooding at private price (Chincha river)

(1,000 soles)

Description	T=50 years	
	Without Project	With Project
Agricultural Product	54,563	14,279
Hydraulic Structure	23,045	3,735
Road	15,694	7,659
Housing	7,599	3,308
Public Facility	1,987	836
Public Service	1,058	129
Total	103,947	29,945

In the Table 4.5.1-3, the estimated amounts of loss by flooding of different return periods with or without Project is shown.

Table 4.5.1-3 Loss estimated value (at private prices)

(10³ Soles)

Case	t	Private Price
		Chincha
Without Project	2	15,262
	5	39,210
	10	55,372
	25	77,797
	50	103,947
	Total	291,588
With Project	2	449
	5	3,005
	10	4,309
	25	14,282
	50	29,945
	Total	51,991

The estimated loss by flood without project in return period of 50- year will be 103.9 million soles in Chincha.

3) Loss amount (annual average) expected to be reduced by the Project

The average annual damage reduction amount is calculated by multiplying the annual damage reduction corresponding to probable flood with occurrence probability and by accumulating the annual damage reduction of each probable flood.

The calculation method is as shown in the Table 4.5.1-4.

Table 4.5.1-4 Calculation method of annual average of loss reduction amount

Probabilities	Loss Amount			Average path's loss	Paths' Probabilities	Loss reduction annual average amount
	Without Project	With Project	Loss Reduction			
1/1			$D_0 = 0$			
1/2	L_1	L_2	$D_1 = L_1 - L_2$	$(D_0 + D_1)/2$	$1 - (1/2) = 0,500$	$d_1 = (D_0 + D_1)/2 \times 0,67$
1/5	L_3	L_4	$D_2 = L_3 - L_4$	$(D_1 + D_2)/2$	$(1/2) - (1/5) = 0,300$	$d_2 = (D_1 + D_2)/2 \times 0,300$
1/10	L_5	L_6	$D_3 = L_5 - L_6$	$(D_2 + D_3)/2$	$(1/5) - (1/10) = 0,100$	$d_3 = (D_2 + D_3)/2 \times 0,100$
1/20	L_7	L_8	$D_4 = L_7 - L_8$	$(D_3 + D_4)/2$	$(1/10) - (1/20) = 0,050$	$d_4 = (D_3 + D_4)/2 \times 0,050$
1/30	L_9	L_{10}	$D_5 = L_9 - L_{10}$	$(D_4 + D_5)/2$	$(1/20) - (1/30) = 0,017$	$d_5 = (D_4 + D_5)/2 \times 0,017$
1/50	L_{11}	L_{12}	$D_6 = L_{11} - L_{12}$	$(D_5 + D_6)/2$	$(1/30) - (1/50) = 0,013$	$d_6 = (D_5 + D_6)/2 \times 0,013$
1/100	L_{13}	L_{14}	$D_7 = L_{13} - L_{14}$	$(D_6 + D_7)/2$	$(1/50) - (1/100) = 0,010$	$d_7 = (D_6 + D_7)/2 \times 0,010$
Foreseen average annual amount of loss reduction				$d_1 + d_2 + d_3 + d_4 + d_5 + d_6 + d_7$		

4) Results of the loss amount calculation (annual average)

In Table 4.5.1-5 the results of the loss amount calculation are shown (annual average), which are expected to be reduced by implementing each river's Project.

Table 4.5.1-5 Annual average of loss reduction amount (private prices)

Basin	Return Period	Probability	Total Damage (10 ⁶ Soles)			Average Damage ④	Section Probability ⑤	Annual Average Damage ⑥=④×⑤	Accumulation of Annual Average Damage
			Without Project ①	With Project ②	Damage Reduction ③=①-②				
CHINCHA	1	1.000	0	0	0		0	0	
	2	0.500	15,262	449	14,813	7,406	0.500	3,703	3,703
	5	0.200	39,210	3,005	36,205	25,509	0.300	7,653	11,356
	10	0.100	55,372	4,309	51,063	43,634	0.100	4,363	15,719
	25	0.040	77,797	14,282	63,515	57,289	0.060	3,437	19,156
	50	0.020	103,947	29,945	74,002	68,758	0.020	1,375	20,532

(2) Social assessment

1) Assessment's objective and indicators

The social assessment's objective in this Study is to evaluate investment's efficiency in structural measures using the analysis method of cost-benefit (C/B) from the national economy point of view. For this, economic assessment indicators were determined (relation C/B, Net Present Value - NPV and IRR). The internal return rate (IRR) is an indicator that denotes the efficiency of the project's investment. It is the discount rate to match the current value of the project's generated cost regarding the benefit's current value. It is the discount rate necessary so the Net Present Value (NPV) equals zero and the relation C/B equals one. It also indicates the percentage of benefits generated by such investment. The internal return rate used in the economic assessment is called "economical internal return rate (EIRR)". The market price is turned into the economical price (costs at social prices) eliminating the impact of market distortion.

The IRR, C/B relation and NPV are determined applying mathematical expressions shown in the Table below. When IRR is greater than the social discount rate, the relation C/B is greater than one and NPV is greater than zero, it is considered that the project is efficient from the national economic growth point of view.

Table 4.5.1-6 Evaluation indicator of economic benefit and its characteristics

Indicators	Definition	Characteristics
Net Present Value (NPV)	$NPV = \sum_{i=1}^n \frac{B_i}{(1+r)^i} - \sum_{i=1}^n \frac{C_i}{(1+r)^i}$	<ul style="list-style-type: none"> - Allows comparing net benefit magnitude performed by the project - It varies depending on the social discount rate
Cost-Benefit Relation (C/B)	$B/C = \sum_{i=1}^n \frac{B_i}{(1+r)^i} / \sum_{i=1}^n \frac{C_i}{(1+r)^i}$	<ul style="list-style-type: none"> - Allows comparing the investment efficiency by the magnitude of benefit per investment unit - Varies depending on the social discount rate
Economical Internal Return Rate (EIRR)	$\sum_{i=1}^n \frac{B_i}{(1+r)^i} = \sum_{i=1}^n \frac{C_i}{(1+r)^i}$	<ul style="list-style-type: none"> - Allows knowing the investment efficiency comparing it to the social discount rate - Does not vary depending on the social discount rate

Where Bi: benefit per "i" year / Ci: cost per "i" year / r: social discount rate (11 %) / n: years of assessment

2) Assumptions

Next, find the assumptions of every indicator used from the economical assessment

i) Assessment period

The assessment period is set between 2013 and 2027 (15 years after construction works started).

This Project implementing schedule is the following:

2012: Detailed Design

2013-2014: Construction

2013-2027: Assessment Period

The assessment period is 15 years which is same period as the adopted period in the Perfil program report of this Project. The SNIP regulation stipulates that the assessment period is to be 10 years basically, however the period can be changed if the project formulation agency (DGIH in this Project) admits that it is necessary. DGIH adopted 15 years in the Perfil program report and which was approved by OPI and DGPI (March 19, 2010). In JICA's development project the evaluation period of 50 years is generally adopted, so that JICA Study Team inquired DGIH and OPI on this matter, they directed to adopt 15 years. In case of 50 years, the evaluation will be made in the Annex-14, Implementation Program of Japan Yen Loans Project.

ii) Standard conversion factor (SCF)

The standard conversion factor (SCF) is the relationship between socioeconomic prices established along the border and national private prices of all goods in a country's economy. It is used to convert goods and services prices purchased in the local market at affordable prices. SCF is stipulated by MEF as shown in the previous Table 4.4.2-1.

iii) Other preliminary conditions

Price level: 2011

Social discount rate: 10% (according to SNIP regulation)

Annual maintenance cost: estimated in the Table 4.4.1-14

3) Cost-benefit relation analysis

A comparison of the total cost and total benefit of flood control works converted to present values applying the social discount rate was performed. In this case, the total cost is the addition of construction, operation and maintenance costs. The total benefit is the loss amount that was reduced due to the works. For this, a base year was established for the conversion into the current value at the moment of the assessment, and the assessment period was set for the next 15 years from the beginning of the Project. The total cost was determined adding-up the construction, operation and maintenance costs of the works converted into present values; and the total benefit adding-up the annual average loss amount turned into current values. In Table 4.5.1-7 results of calculations C/B, NPV and IRR to private prices is shown.

Table 4.5.1-7 Social assessment (C/B, NPV, IRR) (at private prices)

流域 Basin	年平均被害軽減額	評価期間被害 軽減額(15年)	事業費	維持管理費	B/C	Net Present Value (NPV)	Internal Rate of Return (IRR)
	Average Annual Damage Reduction Amount	Damage Reduction Amount in Evaluation Period(15years)	Project Cost	Operation & Maintenance Cost	Benefit and Cost Ratio	Valor Actual Neto (VAN)	Tasa Interna de Retorno (TIR)
Chincha	266,913,530	120,532,859	47,024,405	5,653,615	2.76	76,905,695	35%

The social evaluation at private price level is calculated as shown in the Table 4.5.1-8 for Chincha river.

4.5.2 Social Prices Costs

(1) Benefits

1) Estimated loss amount according to different return periods

The loss amount according to the different return periods is calculated as shown in the Table 4.5.2-1. For further detail refer to I-7 Data Book.

Table 4.5.2-1 Estimated loss by flooding at social price (Chincha river)
(1,000 soles)

Description	T=50 years	
	Without Project	With Project
Agricultural Product	92,694	22,227
Hydraulic Structure	19,059	3,088
Road	12,398	6,051
Housing	6,437	2,802
Public Facility	1,683	708
Public Service	837	103
Total	133,108	34,979

In the Table 4.5.2-2, the estimated amounts of loss by flooding of different return periods with or without Project are shown.

Table 4.5.2-2 Loss estimated value (at social prices)

Case	t	Social Price
		Chincha
Without Project	2	16,758
	5	44,275
	10	74,539
	25	101,437
	50	133,108
	Total	370,117
With Project	2	456
	5	4,859
	10	6,955
	25	18,932
	50	34,979
	Total	66,181

2) Loss amount (annual average) is expected to be reduced with the Project

In Table 4.5.2-3 results of loss amount calculation (annual average) that are expected to reduce to implement the Project are shown.

Table 4.5.2-3 Annual average of loss reduction amount (Social prices)

Basin	Return Period	Probability	Total Damage (10 ⁶ Soles)			Average Damage ④	Section Probability ⑤	Annual Average Damage ⑥=④×⑤	Accumulation of Annual Average Damage
			Without Project ①	With Project ②	Damage Reduction ③=①-②				
			(10 ⁶ Soles)						
CHINCHA	1	1.000	0	0	0		0	0	
	2	0.500	16,758	456	16,302	8,151	0.500	4,076	4,076
	5	0.200	44,275	4,859	39,416	27,859	0.300	8,358	12,433
	10	0.100	74,539	6,955	67,584	53,500	0.100	5,350	17,783
	25	0.040	101,437	18,932	82,505	75,044	0.060	4,503	22,286
	50	0.020	133,108	34,979	98,129	90,317	0.020	1,806	24,092

(2) Social assessment

In Table 4.5.2-4 results of the calculation C/B, NPV and IRR at social prices are shown.

Table 4.5.2-4 Social assessment (C/B, NPV, IRR) (at social prices)

流域 Basin	年平均被害軽減額	評価期間被害 軽減額(15年)	事業費	維持管理費	B/C	Net Present Value (NPV)	Internal Rate of Return (IRR)
	Average Annual Damage Reduction Amount	Damage Reduction Amount in Evaluation Period(15years)	Project Cost	Operation & Maintenance Cost	Benefit and Cost Ratio	Valor Actual Neto (VAN)	Tasa Interna de Retorno (TIR)
Chincha	313,198,474	141,434,223	39,164,079	4,822,421	3.89	105,033,115	47%

The social evaluation at social price level is calculated as shown in the Table 4.5.1-9 for Chincha river.

4.5.3 Social Assessment Conclusions

The social evaluation of this Project is shown as follows:

(1) The economic viability of the project in Chincha basin is confirmed.

Also, the following hardly quantifiable positive economical Projects effects are shown:

- Contribution to local economic development when soothing the fear due to economic activities suspension and damage
- Contribution by increasing local employment opportunities for the construction of the project
- Strengthening the local population's awareness for floods damage and other disasters
- Income increase contributions due to an stable agricultural production because flood damages are soothed
- Increase of agricultural land price

For the economic assessment results previously presented, it is considered that this Project will contribute substantially to the local economic development.

4.6 Sensitivity Analysis

(1) Objective

A sensitivity analysis was made in order to clarify the uncertainty due to possible changes in the future of the socioeconomic conditions. For the cost-benefit analysis it is required to foresee the cost and benefit variation of the project, subject to assessment, to the future. However, it is not easy to perform an adequate projection of a public project, since this is characterized for the long period required from planning to the beginning of operations. Also because of the long useful life of works already in operation and the intervention of a number of uncertainties that affect the future cost and benefit of the project. So, analysis results are obtained frequently and these are discordant to reality when the preconditions or assumptions used do not agree with reality. Therefore, for the uncertainty compensation of the cost-benefit analysis it should be better to reserve a wide tolerance-margin, avoiding an absolute and unique result. The sensitivity analysis is a response to this situation.

The objective of the sensitivity analysis is to provide the cost-benefit analysis results a determined margin that will allow a proper managing of the project's implementation, give numbers to the population and achieve greater accuracy and reliability of the project's assessment results.

(2) Sensitivity analysis

1) General description of the sensitivity analysis

There are three methods of the sensitivity analysis, as indicated in Table 4.6-1.

Table 4.6-1 Sensitivity analysis methods

Methods	Description	Products
Variables sensitivity analysis	It consists in changing only one predetermined variable (precondition or hypothesis), to assess how the analysis result is affected	Margin values from the analysis when a precondition or hypothesis varies
Better and worst alternatives	It consists in defining the cases in which the analysis results are improved or worsen when changing the main pre-established preconditions or hypothesis to assess the analysis result margin	Margin values from the analysis when the main precondition or hypothesis vary
Monte Carlo	It consists in knowing the probability distribution of the analysis results by simulating random numbers of Monte Carlo simulation of pre-established preconditions and hypothesis	Probable results distribution when all main precondition or hypothesis vary

2) Description of the sensitivity analysis

In this project the sensitivity analysis method of the variables usually used in public works investments was adopted. Next, the scenarios and economic indicators used in the sensitivity analysis are shown.

Table 4.6-2 Cases subjected to the sensitivity analysis and economic indicators

Indicators	Variation margin according to factors	Economic indicators to be evaluated
Construction cost	In case the construction cost increases in 5 % and 10 %	IRR, NPV, C/B
Benefit	In case of reducing the benefit in 5 % and 10 %	IRR, NPV, C/B
Social discount rate	In case of increase and reduction of the discount social rate in 5 % respectively	NPV, C/B

3) Results of the sensitivity analysis

In Table 4.6-3 the results of the sensitivity analysis of each assessed case to private and social prices are shown.

Table 4.6-3 Results of the sensitivity analysis of IRR, C/B and NPV

	Basin	Item	Basic Case	Case 1	Case 2	Case 3	Case 4	Case 5	Case 6
				Cost increase 5%	Cost increase 10%	Benefit decrease 5%	Benefit decrease 10%	Disc. rate increase 5%	Disc. rate decrease 5%
PRIVATE PRICE	CHINCHA	IRR (%)	35%	33%	32%	33%	32%	35%	35%
		B/C	2.76	2.64	2.53	2.62	2.49	2.14	3.68
		NPV(s)	76,905,695	74,851,989	72,798,284	70,879,052	64,852,409	46,239,359	127,369,505
SOCIAL PRICE	CHINCHA	IRR (%)	47%	45%	43%	45%	43%	47%	47%
		B/C	3.89	3.71	3.55	3.69	3.50	3.01	5.17
		NPV(s)	105,033,115	103,321,945	101,610,775	97,961,404	90,889,692	67,971,426	165,573,203

(3) Assessment of the sensitivity analysis

The impact on the economic evaluation due to the socio-economic change in the Project is as follows:

As to Chincha river, the project has high economic viability even in the base case so that IRR, B/C and NPV have no significant variation for the change of cost or benefit of the projects, and they are still effective projects.

4.7 Risk Analysis

The risk analysis is performed for flood prevention facilities of Chincha basin.

(1) Definition of risk

The increase % of cost and decrease % of benefit which make NPV value equal to zero, are calculated, then the magnitude of risk is defined as shown below.

High risk : When the cost increases from 0% to less than 15% or the benefit decrease from 0% to less than 15%, NPV becomes zero.

Middle risk: When the cost increases more than 15% to less than 30% or the benefit decrease

more than 15% to less than 30%, NPV becomes zero.

Low risk: When the cost increases more than 30% or the benefit decrease more than 30%, NPV becomes zero.

(2) Magnitude risk in each basin

The increase % of cost and decrease % of benefit which make NPV equal to zero, are calculated as shown in the Table 4.7-1. According to the Table, the risk is very low in Chincha basin

Table 4.7-1 Increase % of cost and decrease % of benefit for NPV=0%

Basin	(Amount:1,000 soles)							
	Construction Cost				Benefit			
	Base Case	Increase	Rate (%)	Risk	Base Case	Decrease	Rate (%)	Risk
Chincha	41,379	188,403	355%	low	141,434	36,401	74%	low

4.8 Sustainability Analysis

This project will be implemented by the central government (through the DGIH), irrigation committees and regional governments. Also, the project cost will be covered with the respective contributions of the three parties. Although the sharing percentage will be determined through discussions among stake holders, the percentage is assumed provisionally 80% for the central government (in this case MINAG), 15% for regional government and 5% for irrigation committee. On the other hand, the operation and maintenance (O & M) of the completed works is assumed by the irrigation committee. So, the sustainability of the project depends on the profitability of the Project and the ability of the irrigation committees for O & M.

(1) Profitability

The profitability of project in Chincha basin is high enough as shown in 4.5 social evaluation so that there is no questionable point in the sustainability of the Project.

(2) Irrigation committee

The irrigation committee is non-profitable organization established by local people based on the law (Resolución Ministerial N° 0837-87-AG) issued on October 14, 1987.

Peru irrigation committee is composed of 114 committees which are divided into 1582 sectors. It is registered to the National Committee (Junta Nacional, composed of 7 members elected by all irrigation committees) and acts as an representative of agricultural sector in all Peru, and recognized in the various sectors such as public and private agricultural departments. Each irrigation committee is composed of plural irrigation sectors. The irrigation sector means the unit irrigation area which has same characteristics of irrigation area with same topography, and same intake, secondary and thirdly irrigation canals etc.

The decisions of committee is made by the Assignment Board (Cesión de Consejo Directivo) held twice per month, which is composed of 7 members such as president, vice president, secretary, 2-directors, accountant and assistant accountant etc. The main task of the committee is as follows:

- To promote the agreement of will among members and to integrate members' will as the opinion of the committee
- Effective and fair distribution of water resources
- Administration and operation and maintenance of hydraulic facilities
- Education and capacity building for water resources
- Promotion of agricultural development and increase of life quality by increase of income

(3) Capacity of operation and maintenance

The recent annual budget of the irrigation committee of Chincha basin is as shown in the Table 4.8-1.

Table 4.8-1 Irrigation Committee's budget

Rivers	Annual Budget			(Unit/ S)
	2007	2008	2009	2010
Chincha	1,562,928.56	1,763,741.29	1,483,108.19	-

The annual revenue of irrigation committee is composed of ① irrigation water cost (/m3), ② rental cost of heavy equipment to private company etc. and there is no governmental subsidy. And the annual expenditure is composed of ① operation cost of intake facilities (operator cost of intake weir etc.) ② operation and maintenance cost for such as irrigation canal and intake etc., ③ investigation cost for upgrading of irrigation facilities, ④ operation cost for irrigation committee office.

On the other hand the required operation and maintenance cost is as shown in the Table 4.8-2 according to the clause 4.4.1. The ratio of O/M cost to the annual budget in 2009 and to the annual average of the damage reduction amount are also as shown in the same table.

The ratio of O/M cost to the annual budget in 2009 is 29.3 % in Chincha river. On the other hand the ratio of O/M cost to the annual average of the damage reduction amount is 2.1 %, which seems to be very low. The ratio of O/M cost to the annual budget seems to be rather high, however the ratio of O/M cost to the annual average flood damage amount is very low so that after the flood damage is reduced and profit of farmer increase, it is quite possible that the irrigation committee bears the O/M cost.

And the committee has heavy equipment such as bull-dozer, excavator, trailer, dump truck etc. and performed maintenance works for dike, revetment, intake, irrigation channel etc. therefore the committee could carry out the O/M of the facilities constructed in the Project under the technical assistance of MINAG and the regional government.

Table 4.8-2 Ratio of O/M cost to annual budget and damage reduction amount

Irrigation Committee	Annual Budget(1,000soles)	O/M Cost(1,000soles)	Percentage of O/M cost(%)	Average Yearly Damage Reduction(1,000soles)	Percentage of O/M cost(%)
	①	②	③=②/①	④	⑤=②/④
Chincha	1,483	435	29.3	20,532	2.1

(4) Agreement with irrigation committee

The following items are to be discussed and made agreement between the central government (MINAG) and the irrigation committee as soon as possible.

- Sharing ratio of Project cost
- Delivery of flood prevention facilities
- O/M of facilities
- Delivery of plantation along river structure and O/M

4.9 Environmental Impact

4.9.1 Procedure of Environmental Impact Assessment

Projects are categorized in three scales, based on the significance level of the negative and positive impacts, and each sector has an independent competence on this categorization. The following table shows the environmental management instruments that are required for each category. The Project holder should submit the Environmental Impact Statement (DIA, in Spanish) for all Projects under Category I. The project holder should prepare an EIA-sd or an EIA-d if the Project is categorized under Category II or III, respectively, to be granted the Environmental Certification from the relevant Ministry Directorate.

Table 4.9.1-1 Project categorization and environmental management instruments

	Description	Required Environmental Management Instrument
Category I	It includes those Projects that when carried out, they cause no significant negative environmental impacts whatsoever.	PEA that is considered a DIA after the assessment for this category
Category II	It includes those Projects that when carried out, they can cause moderate environmental impacts, and their negative effects can be removed or minimized through the adoption of easily applicable measures.	Semi-Detailed Environmental Impact Assessment (EIA-sd)
Category III	It includes those Projects than can cause significant quantitative or qualitative negative environmental impacts because of their characteristics, magnitude and/or location. Therefore, a deep analysis is required to revise those impacts and set out a relevant environmental management strategy.	Detailed Environmental Impact Assessment (EIA-d)

Source: Prepared by the JICA Study Team based on the SEIA Law (2001)

The next graph shows the Environmental Document's Classification, the Environmental Document's Assessment, and the Environmental Certification.

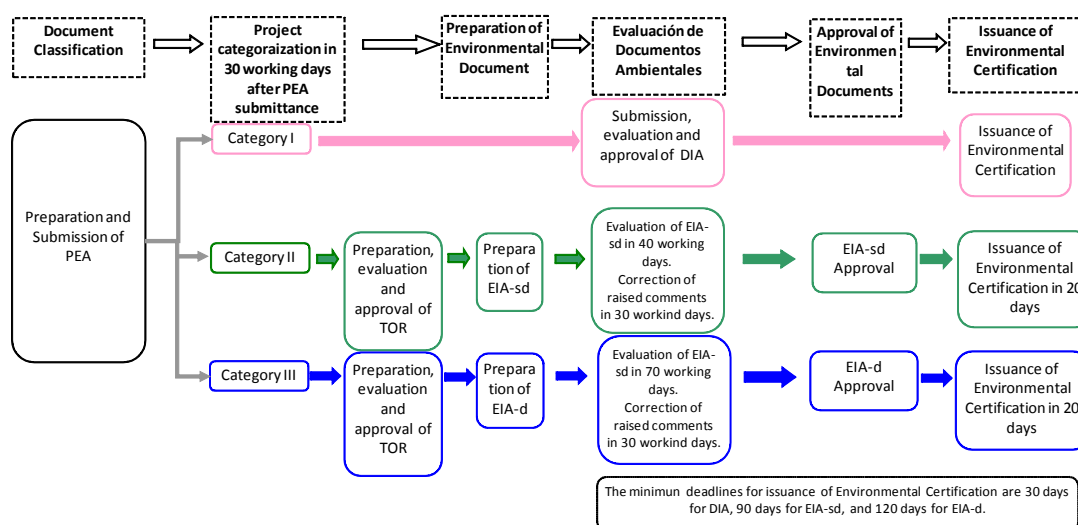

Source: Prepared by the JICA Study Team based on the SEIA Regulations (2009)

Figure 4.9.1-1 Process to obtain the environmental certification

First, the Project holder applies for the Project classification, by submitting the Preliminary Environmental Assessment (PEA). The relevant sector assesses and categorizes the Project within the next 30 working days after the document's submission. The Project's PEA that is categorized under Category I becomes an EID, and those Projects categorized under Category II or III should prepare an EIA-sd or EIA-d, as applicable. There are cases in which the relevant sector prepares the Terms of Reference for these two studies, and submits them to the holder. There are other cases in which the holder prepares the Terms of Reference and these are approved by the relevant sector, based on the interview with DGAA. Number of working days required for EIA-sd revision and approval is 90, and number of working days required for EIS-d is 120; however, these maximum deadlines may be extended.

The progress of the environmental impact study is as shown below.

The JICA Study Team subcontracted a local Consultant (CIDE Ingenieros S.A.), and a Preliminary Environmental Assessment (PEA) was carried out, from December 2010 to January 2011 for Chincha river.

EAP for the Chincha river was submitted to DGIH from JICA on January 25, 2011. DGIH submitted the EAP to DGAA on July 19, 2011. EAP for Chincha river was examined by DGAA, and DGAA issued their comments on EAP to DGIH. JICA Study Team revised EAP upon the comments and submitted it to DGAA on September 21, 2011. DGAA completed examination on the revised EAP and issued approval letter on Chincha river in which DGAA classified Chincha river into Category I. Therefore the additional environmental impact analysis for Chincha river is not required.

The positive and negative environmental impact associated with the implementation of this project was confirmed and evaluated, and the plan for prevention and mitigation measures are prepared by EAP results, field investigation and hearing by JICA Study Team.

The proposed works in this project include: the reparation of existing dikes, construction of new dikes, riverbed excavation, bank protection works, repair and improvement of the derivation and intakes works, and also river expansion. Table 4.9.1-2 describes “working sites” to be considered in the Environmental Impact section for Chincha river.

Table 4.9.1-2 Works description

River	Location		Critical Point	Main Protection Objects	Measure	Feature of Work	
Rio Chincha	Chico-1	2.9-5.0 km	Innuded Point	Agricultural Lands (Apple, Grape, Cotton, etc.), Intake Weir	Dike with Bank Protection	Length Dike with Bank Protection Large Boulder Riplap	3,150 m 60,160 m ³ 23,700 m ³
	Chico-2	14.7-15.3 km	Existion Intake Weir (w:100m, H:3.0m, crest w:2.0m)		Riverbed excavation, Dike with Bank Protection	Riverbed Excavation Dike with Bank Protection Large Boulder Riplap	L=540 m, V=20,000 m ³ L=850 m, V=5,500 m ³ 23,700 m ³
	Chico-3	24.0-24.4 km	Existing Intake Weir (w:70m, H: 3.0m, crest w:2.0m)		Intake Weir/ Dike with Bank Protection	Construction of Intake Weir Dike with Bank Protection Large Boulder Riplap	Ground Sill 1 V=5,200 m ³ Diversion Weir 1 V=4,300 m ³ L=730 m, V=20,350 m ³ 7,400 m ³
	Ma-1	2.5-5.0 km	Innuded Point		Dike with Bank Protection	Length Dike with Bank Protection Large Boulder Riplap	4,630 m 49,900 m ³ 37,000 m ³
	Ma-2	8.0-10.5km	Narrow Section		Riverbed excavation, Dike with Bank Protection	Riverbed Excavation Dike with Bank Protection Large Boulder Riplap	L=2,500 m, V=123,500 m ³ L=4,080 m, V=37,700 m ³ 32,200 m ³

Source: JICA Study Team

4.9.2 Methodology

In order to identify environmental impacts of the works to be executed in the different watersheds, we developed identification impact matrixes for watershed.

First, the operation and activities for each project based on typical activities of “hydraulic works” construction were determined. Afterwards, the concrete activities type was determined which will be executed for each work that will be developed in the watersheds. Then, to evaluate Socio-environmental impacts the Leopold matrix was used.

Table 4.9.2-1 Evaluation criterion - Leopold matrix

Index		Description	Valuation
“Na” nature		It defines whether change in each action on the means is positive or negative	Positive (+) : beneficial
			Negative (-): harmful
Probability of Occurrence “P.O.”		It includes the probability of occurrence of the impact on the component	High (>50 %) = 1.0
			Medium (10 – 50 %) = 0.5
			Low (1 – 10 %) = 0.2
Magnitude	Intensity (In)	It indicates the magnitude of change in the environmental factor. It reflects the degree of disturbance	Negligible (2)
			Moderate intensity (5)
			Extreme Disturbance (10)
	Extension “Ex”	It indicates the affected surface by the project actions or the global scope on the environmental factor.	Area of indirect influence: 10
			Area of direct influence: 5
			Area used up by the works: 2
	Duration “Du”	It refers to the period of time when environmental changes prevail	> 10 years: 10
			5 – 10 years : 5
			1 – 5 years: 2
	Reversibility “Rev”	It refers to the system's capacity to return to a similar, or an equivalent to the initial balance.	Irreversible: 10
Partial return: 5			
Reversible: 2			

Source: Prepared based on PEAs of 6 Basins

Table 4.9.2-2 Impact significance degrees

SIA	Extent of Significance
≤ 15	Of little significance
15.1 - 28	Significant
≥ 28	Very significant

Source: Prepared based on PEAs of 6 Basins

4.9.3 Identification, Description and Social Environmental Assessment

(1) Identification of social environmental impacts

In the following matrix (construction/operation stages) in the watershed, elaborated based on the report analysis of the Preliminary Environmental Assessment.

Table 4.9.3-1 Impact identification matrix (construction and operation stage) – Chincha river

Construction Stage			Work	1-5	1-5	1-5	2,3	1,4,5	1-4	1-5	1-5	1-5	1-5	1-5	Total Negative		Total Positive				
Environment	Component	Environmental Factor	Activity																		
			Labor Recruitment	Site preparation work (Clearing, land grading, Levelled)	Ditch of trenches (Coffin dams)	Digging and setting in the site	Digging and setting in the bed	Civil Work (Concrete)	ISO of the pits and material production plants	DIME ISO	Camps work ISO	Cantante Staff	Transportation of machinery, equipment, materials and supplies								
Physical	Air	PM10 (Particulate matter)		N	N	N	N	N	N	N	N	N	N	N	8	0					
		Gas emissions		N	N	N	N	N	N	N	N	N	N	N	8	0					
	Noise	Noise		N	N	N	N	N	N	N	N	N	N	N	19	0					
		Soil fertility		N											3	0					
	Soil	Land Use		N								N	N		3	0					
		Water	Cantidad del agua superficial			N	N	N			N	N			4	0					
Hydrography	Terrestrial flora													2	0						
	Terrestrial fauna													4	0						
Biotic	Iora	Terrestrial flora												2	0						
		Aquatic flora												4	0						
	Runa	Terrestrial fauna												2	0						
Socio-economic	Education	Visual landscape										N	N		0	0					
		Quality of life		P											3	1					
	Social	Vulnerability - Security													0	0					
		PEA		P											0	1					
Economic	Current land use													0	0						
Total				2	8	7	7	7	3	10	9	3	4	4	61	2					
Percentage of total positive and negative															67%	3%					

Operation Stage			Work	Dike Clikoo 1	Intake Clikoo 2	Parklor Clikoo 3	Dike Ma 1	Pirize without sitting base	Total Negative	Total Positive
Environment	Component	Environmental Factor	Activity							
			Physical	Air	PM10 (Particulate matter)					
Gas emissions									0	0
Noise	Noise								0	0
	Soil fertility								0	0
Soil	Land Use								0	0
	Water	Cantidad del agua superficial			P				0	1
Hydrography	Terrestrial flora			P				0	1	
	Terrestrial fauna							0	0	
Biotic	Iora	Terrestrial flora						0	0	
		Aquatic flora						0	0	
	Runa	Terrestrial fauna						0	0	
Socio-economic	Education	Visual landscape		P	P	P	P	P	0	4
		Quality of life		P	P	P	P	P	0	5
	Social	Vulnerability - Security		P	P	P	P	P	0	5
		PEA							0	0
Economic	Current land use		P	P	P	P	P	0	5	
Total				7	6	7	7	7	21	26
Percentage of total positive and negative									21%	79%

N: Negative, P:Positive

Source: Prepared by the JICA Study Team

On the Chincha River basin, based on the impact identification results for the construction stage, a total number of 64 interactions have been found. 62 of these interactions (97 %) correspond to impacts that will be perceived as negative, and 2 (3 %) correspond to impacts that will be perceived as positive. In addition, 33 interactions have been found for the operation stage; 7 of these interactions (21 %) correspond to impacts that will be perceived as negative, and 26 (79 %) correspond to impacts that will be perceived as positive.

(2) Environmental and social impact assessments

Environmental and social impacts are assessed with the methodology that was explained in 4.9.2 Methodology. The following tables show the environmental and social assessment results for the basin, during the construction and operation stages.

Table 4.9.3-2 Environmental impact assessment matrix – Chincha river

		The Chincha River Basin																							
Medio	Componente	Acciones del proyecto	Construction Stage										Operation Stage												
			Labor Recruitment		Site preparation work (Clearing, land grading, Levelled)		Division of riverbed (Cofferdams)		Digging and refilling in riverside		Digging and refilling in riverbed		Civil Work (Concreting)		I&O of stone pits and material production plants		DME I&O	Camps work I&O	Carriage Staff	Transportation of machinery, equipment, materials and supplies	Chico1	Chico2	Chico3	Ma1	Ma2
			Factores Ambientales		Todos	Todos	Todos	Chico 2 y 3	Chico 1, Ma 1 y 2	Chico 1, 2, 3, Ma1	Todos	Todos	Todos	Todos	Todos	Todos	Todos								
Physique	Air	PM-10 (Particulate matter)	0.0	-12.0	-12.0	-12.0	-12.0	0.0	-18.0	-18.0	0.0	-12.0	-12.0	0.0	0.0	0.0	0.0	0.0	0.0	0.0	0.0	0.0	0.0		
		Gas emissions	0.0	-11.5	-11.5	-11.5	-11.5	-11.5	-11.5	-11.5	-11.5	0.0	-11.5	-11.5	0.0	0.0	0.0	0.0	0.0	0.0	0.0	0.0	0.0	0.0	
	Noise	Noise	0.0	-15.0	-15.0	-15.0	-15.0	-15.0	-15.0	-15.0	-15.0	-15.0	-15.0	-15.0	0.0	0.0	0.0	0.0	0.0	0.0	0.0	0.0	0.0	0.0	
		Soil fertility	0.0	-11.5	0.0	0.0	0.0	0.0	0.0	0.0	-14.2	-14.2	0.0	0.0	0.0	0.0	0.0	0.0	0.0	0.0	0.0	0.0	0.0	0.0	
	Soil	Land Use	0.0	-14.2	0.0	0.0	0.0	0.0	0.0	-15.0	-15.0	0.0	0.0	0.0	0.0	0.0	0.0	0.0	0.0	0.0	0.0	0.0	0.0	0.0	
		Calidad del agua superficial	0.0	0.0	-17.5	-12.0	-23.0	0.0	-15.0	0.0	0.0	0.0	0.0	0.0	0.0	0.0	28.0	0.0	0.0	0.0	0.0	0.0	0.0	0.0	
	Water	Cantidad de agua superficial	0.0	0.0	0.0	0.0	0.0	-9.0	0.0	0.0	0.0	-15.0	0.0	0.0	0.0	26.0	31.0	26.0	26.0	31.0	26.0	26.0	31.0	31.0	
Physiography	Morfología fluvial	0.0	0.0	-12.0	-20.0	-31.0	0.0	-23.0	0.0	0.0	0.0	0.0	0.0	0.0	-25.5	0.0	26.0	-25.5	-30.5	0.0	0.0	0.0	0.0		
	Morfología terrestre	0.0	-33.0	0.0	0.0	0.0	0.0	0.0	-28.0	0.0	0.0	0.0	0.0	0.0	0.0	0.0	0.0	0.0	0.0	0.0	0.0	0.0	0.0		
Biotic	Flora	Terrestrial flora	0.0	-28.0	0.0	0.0	0.0	0.0	0.0	-22.5	0.0	0.0	0.0	0.0	0.0	0.0	0.0	0.0	0.0	0.0	0.0	0.0	0.0		
		Aquatic flora	0.0	0.0	-12.0	-14.5	-14.5	0.0	-14.5	0.0	0.0	0.0	0.0	0.0	0.0	0.0	0.0	0.0	0.0	0.0	0.0	0.0	0.0	0.0	
		Terrestrial fauna	0.0	-24.2	0.0	0.0	0.0	0.0	0.0	0.0	-22.5	0.0	0.0	0.0	0.0	0.0	0.0	0.0	0.0	0.0	0.0	0.0	0.0	0.0	
	Fauna	Aquatic fauna	0.0	0.0	-12.0	-14.5	-22.5	0.0	-15.0	0.0	0.0	0.0	0.0	0.0	0.0	-25.5	0.0	-25.5	-25.5	-30.5	0.0	0.0	0.0	0.0	
		Visual landscape	0.0	0.0	0.0	0.0	0.0	0.0	0.0	-12.0	-12.0	0.0	0.0	0.0	0.0	36.0	0.0	36.0	36.0	36.0	36.0	36.0	36.0	36.0	
Socio-economic	Esthetic	Quality of life	17.0	0.0	0.0	0.0	0.0	0.0	0.0	0.0	0.0	-17.5	-17.5	-17.5	36.0	31.0	36.0	36.0	36.0	36.0	36.0	36.0	36.0		
		Vulnerability - Security	0.0	0.0	0.0	0.0	0.0	0.0	0.0	0.0	0.0	0.0	0.0	0.0	0.0	36.0	31.0	36.0	36.0	36.0	36.0	36.0	36.0		
	Economic	PEA	17.0	0.0	0.0	0.0	0.0	0.0	0.0	0.0	0.0	0.0	0.0	0.0	0.0	0.0	0.0	0.0	0.0	0.0	0.0	0.0	0.0		
		Current land use	0.0	0.0	0.0	0.0	0.0	0.0	0.0	0.0	0.0	0.0	0.0	0.0	0.0	36.0	36.0	36.0	36.0	36.0	36.0	36.0	36.0		



Source: Prepared based on PEAs of 6 Basins

It must be pointed out that in the Chincha River basin only 15 out of a total of 62 negative impacts have been quantified as significant, and 2 have been quantified as very significant, during the construction stage. Meanwhile, out of a total of 7 negative impacts, only 5 have been quantified as significant, and 2 have been quantified as very significant, during the operation stage.

During the construction stage, the works site preparation component will significantly affect the land morphology. At the same time, the Riverbed Excavation and Filling component will affect the “Chico1”, “Ma1”, and “Ma2” points. During the operation stage, river morphology and aquatic fauna will be significantly affected at the “Ma3” points, where the river basin will be unclogged.

During the construction stage, actions that will generate most significant negative impacts along the basin include: “Site Works Preparation and Clearance”, “Riverbed Excavation and Filling”, and “Surplus Material Deposits Operation (DME, in Spanish).” “Site works Preparation and Clearance” will bring about a significant modification to the land morphology, whereas “Riverbed Excavation and Filling” will bring about a significant modification to river morphology.

During the operation stage, hydraulic infrastructure works that will bring about most significant negative environmental impacts include “Riverbed excavation and embankment” that will cause a modification to the river morphology and subsequently, decreased river habitability conditions that will directly impact the aquatic fauna.

Most significant positive impacts are related to all works to be constructed along the river basins, and are directly related to improve the quality of the lives of the population around the area of influence, improve the “Current Use of land / soil”, improve the security conditions, and reduce vulnerability at social and environmental levels.

4.9.4 Socio-Environmental Management Plans

The objective of the Socio-Environmental Plans is to internalize both positive and negative significant and very significant environmental impacts that are related to the Project’s construction and operation stages, so that prevention and/or mitigation of significant and very significant negative impacts, preservation of environmental heritage, and Project sustainability are ensured.

During the construction stage, Project of Cañete river has set out the following measures: “Local Hiring Program”, “Works Sites Management and Control Program”, “Riverbed Diversion Program”, “Riverbank Excavation and Filling Management”, “Riverbed Excavations and Filling Management”, “Quarry Management”, “DME Management”, “Camp and Site Residence Standards”, and “Transportation Activity Management.” During the operation stages, Project for the basin has considered the development of activities with regard to “Riverbed and Aquatic Fauna Management”. These activities should develop riverbed conditioning downstream the intervention points, for erosion probabilities to be reduced, and habitability conditions to be provided for aquatic fauna species. The following are measures related to those negative impacts to be mitigated or those positive impacts to be potentiated. Overall measures have been established for the basin, based on the impacts.

Table 4.9.4-1 Environmental impact and prevention/mitigation measures

Item	Impact	Counter Measures	Period
Natural environment	Water quality of surface water	Management of river diversion and coffering	Construction period
		Management of bank excavation and banking	
		Management of riverbed excavation and back filling	
	River topography	Management of bank excavation and banking	
		Management of riverbed excavation and back filling	
		Management of quarry site	
	Other topography	Management of construction site	
		Management of large amount of excavated or dredged material	
Dust	Management of construction site		
	Management of large amount of excavated and dredged material		
Biological environment	Aquatic fauna	Management of riverbed excavation and back filling	O/M period
	Terrestrial fauna	Management of construction site	Construction period
		Management of large amount of excavated and dredged material	
	Terrestrial flora	Management of construction site	
Management of large amount of excavated and dredged material			
Social environment	Quality of life	Management of labor and construction office	Construction period
		Management of traffic of construction vehicle	
		Employment plan of local people	
	Population of economic activity	Employment plan of local people	

Source: JICA Study Team

4.9.5 Monitoring and Control Plan

(1) Follow up and monitoring plan

The follow-up plan has to implement firmly the management of environmental plan. The monitoring plan is to be carried out to confirm that the construction activity fulfill the environmental standard such as Environmental Quality Standards (EQS) either or Maximum Permissible Limits (MPL). And the monitoring and control must be carried out under the responsibility of the project's owner or a third party under the supervision of the owner.

● Construction stage

During the construction period of the projects to be done in the watershed, the Monitoring and Control Plan will be directed to the verification of the fulfillment measures designed as part of the environmental monitoring plan and the verification of the fulfillment of laws and regulation of the Peruvian Legislation. The following aspects will also be monitored:

Water Quality and Biological Parameters:

Water quality and biodiversity parameters control shall be performed at downstream of these works must be monitored. In the following table the profile of this plan is shown.

Table 4.9.5-1 Monitoring to water quality and biological parameters

Item	Unit	Measured Value (Mean)	Measured Value (Max.)	Country's Standards
pH	pH			"National Standard for Water Quality" D.S. No. 002-2009 MINAM
TSS	mg/l			
BOD/COD	mg/l			
DO	mg/l			
Total Nitrogen	mg/l			
Heavy Metals	mg/l			
Temperature	°C			
Biological Diversity indices: Shannon; Pielou; richness and abundance				

[Measurement Points]

-50 meters upstream the intervention points

-50 meters downstream the intervention points

-100 meters downstream the intervention points

[Frequency]

Quarterly

[Person in charge of Implementation]

DGIH-MINAG, or a third party under the project holder's supervision

Source: JICA Study Team

Air quality:

During impact analysis, in the projects to be developed in the watershed no significant impacts will be seen in the activities related to hydraulic infrastructure works. However, the generation of dust and atmospheric contaminant emissions always affects the working area and the workers and inhabitants health. So, it is recommended to monitor air quality.

Table 4.9.5-2 Monitoring to air quality

Item	Unit	Measured Value (Mean)	Measured Value (Max.)	Peruvian Standards (D.S. No 074-2001-PCM)	Referred International Standards
SO ²				"National Standard for Air Quality" D.S. No.074-2001-PCM	National Ambient Air Quality Standards (NAAQS) (Updated in 2008)
NO ²					
CO					
O ³					
PM-10					
PM-2.5					

[Measurement Points]

*02 stations per monitoring point: Windward and downwind (upwind and against the wind direction)

-1 point at the working zones

-1 point at a quarry, away from the river (the largest and / or the closest point to a populated area)

-1 point at a D.M.E. (the largest and / or the closest point to a populated area)

[Frequency]

Quarterly

[Person in charge of the Implementation]

DGIH-MINAG, or a third party under the project holder's supervision

Source: JICA Study Team

Noise quality

Likewise, it is proposed to perform a noise monitoring at the potential receptors located near the noise emission spots towards the working sites, in the next table 4.9.5-3, the terms are described.

Table 4.9.5-3 Monitoring to noise quality

Item	Unit	Measured Value (Mean)	Measured Value (Max.)	Country's Standards	Referred International Standards
Noise level	LAeqT (dB(A))			National Environmental Quality Standards for noise (EQS) - S.N. N° 085-2003-PCM	-IEC 651/804 – International -IEC 61672- New Law: Replaces IECs 651/804 -ANSI S 1.4 – America

[Measurement Point]

Monitoring to acoustic contamination levels will be carried out at the potential receivers that are located around the noise emission points per work front.

01 point per potential receiver will be monitored.

[Frequency]

Every two months during construction phase

[Person in charge of the Implementation]

DGIH-MINAG, or a third party under the project holder's supervision

Source: JICA Study Team

● Operation stages

Regarding works impact of all projects, it is mainly recommended to monitor biologic parameters and water quality as river topography and the habitat of aquatic life.

Table 4.9.5-4 Monitoring to water quality (operation stage)

Item	Unit	Measured Value (Mean)	Measured Value (Max.)	Country's Standards
pH	pH			"National Standard for Water Quality" D.S. No. 002-2009 MINAM
TSS	mg/l			
BOD/COD	mg/l			
DO	mg/l			
Total Nitrogen	mg/l			
Heavy Metals	mg/l			
Temperature	°C			
Biological Diversity indices: Shannon; Pielou; richness and abundance				

[Measurement Points]

-50 meters upstream the intervention points

-50 meters downstream the intervention points

-100 meters downstream the intervention points

[Frequency]

Quarterly in first two years of operation phase

[Person in charge of Implementation]

DGIH-MINAG, or a third party under the project holder's supervision

Source: JICA Study Team

(2) Closure or abandon plan

Closure or abandon plans have been made for each watershed. These will be executed at the end of construction activities and involves the removal of all temporary works and restoration of intervened and/or affected areas as a result of the works execution. The restoration includes the removal of contaminated soil, disposal of waste material, restoration of soil morphology and restoration with vegetation of intervened sites.

(3) Citizen participation

Citizen participation plans have been made for each watershed, which must be executed before and during construction and when the works are completed. The recommended activities are:

- Before works: Organize workshops in the surrounding community's area near the project and let them know what benefits they will have. Informative materials in communities, which will explain the profile, lapse, objectives, benefits, etc. of the Project
- During works execution: Give out information on the construction progress. Responding complaints generated from the local community during works execution. For this, a consensus wants to be previously achieved with the community in order to determine how claims will be met
- When works are completed: Organize workshops to inform about works completion. Works delivery to the local community inviting local authorities for the transfer of goods, which means the work finished

4.9.6 Cost for the Environmental Impact Management

The cost for the environmental management in this Project is as shown in the Table 4.9.6-1. In the table, (1) shows the cost for the environmental management of each facility, based on which the cost required in the basin (2) is calculated. And the cost for the counter measures 1) – 7) is calculated based on the accumulated construction period of each facility which is described in the Annex-9 Construction Plan/Cost Estimate, Table 2.1-1.

Table 4.9.6-1 Cost of environmental management plan

(1) Cost per one work site					(2) Cost per Basin
Item	Unit	Quantity	Unit Price (S/.)	Parcial Price (S/.)	Chincha Basin (5 sites)
Work duration	Month				30
1) Transportation Activities Program	Month	-	S/. 1,400.0	-	S/. 42,000.0
2) Industrial wastes Management Program	Month	-	S/. 4,200.0	-	S/. 126,000.0
3) Landscape management within the project site	Month	-	S/. 2,800.0	-	S/. 84,000.0
4) Worksite Management Program	Month	-	S/. 1,960.0	-	S/. 58,800.0
5) Noise control program	Month	-	S/. 1,120.0	-	S/. 33,600.0
6) Environmental Management Activities	Month	-	S/. 4,480.0	-	S/. 134,400.0
7) Training for control of foil and water contamination	Month	-	S/. 2,520.0	-	S/. 75,600.0
8) Monitoring to Water Quality, Flow, and Biological Indices				S/. 11,239.20	S/. 56,196.0
Índices de diversidad	Monitoring	3	S/. 672.0	S/. 2,016.00	
Caudal	Monitoring	3	S/. 588.0	S/. 1,764.00	
Tº, pH, OD	Monitoring	3	S/. 571.2	S/. 1,713.60	
DBO	Monitoring	3	S/. 638.4	S/. 1,915.20	
Sólidos disueltos totales	Monitoring	3	S/. 638.4	S/. 1,915.20	
Sólidos suspendidos totales	Monitoring	3	S/. 638.4	S/. 1,915.20	
9) Monitoring to Ari quality and noise				S/. 37,500.0	S/. 187,500.0
Monitoring of air emission	Monitoring	3	S/. 4,500.0	S/. 13,500.0	
Monitoring of PM	Monitoring	3	S/. 5,000.0	S/. 15,000.0	
Monitoring of noise	Monitoring	3	S/. 3,000.0	S/. 9,000.0	
Total					S/. 798,096.0

4.9.7 Conclusions and Recommendations

(1) Conclusions

According to the Preliminary Environmental Appraisals to Chincha basin, most impacts identified during the construction and operation stages were found out to be of little significance. Significant and very significant negative impacts can be controlled or mitigated, as long as suitable Environmental Management Plans are carried out. In addition, the Project will be implemented in the short term, as environmental conditions will be quickly restored. However, the execution of a follow – up and monitoring plan is important, and in the event that unexpected impacts are generated, immediate mitigation measures must be taken.

In addition, significant positive impacts are also present, especially during the operation stage. These positive impacts include: An enhanced security / safety and a decreased vulnerability at social and environmental levels; an improved quality of life among the population in the area of influence, and an improved “Current use of land / soil”.

(2) Recommendations

1) We mainly recommend that the beginning of the construction activities coincides with the beginning of the dry seasons in the region (May to November) when the level of water is very low or the river dries up. The river characteristics / features should be taken into account, that is, that Chincha river is seasonal rivers. At the same time, the crop season cycle in the areas of direct influence should be taken into account, so that traffic jams caused by the large trucks and farming machinery is prevented.

2) It is recommended that the Project holder (DGIH) should define the limit of river area during detailed design stage, and identify the people who live within the river area illegally. Continually the DGIH should carry on the process of land acquisition based on the Land Acquisition Law, which are; Emission of Resolution for land acquisition by the State, Proposition of land cost and compensation for land owner, Agreement of the State and land owner, Payment, archaeological assessment certification.

3) DGIH has to promote the process to obtain the CIRA in the detail design stage. The process to be taken is i) Application form, ii) Copies of the location drawings and outline drawings, iii) voucher, iv) Archaeological Assessment Certificate.

4) The participation of the women in the workshops can be promoted through the existing women group such as Vaso de Leche.

Finally, the DGAA submitted the resolutions (Environmental Permissions) for Chincha basin. The Projects has been categorized as “Category I”, which means that the Projects is not required to carry out neither EIA-sd nor EIA-d.

4.10 Institutions and Administration

Peruvian institutions regarding the Project’s execution and administration are the Agriculture Ministry, Economy and Finance Ministry and Irrigation Commission, with the following roles for each institution. The following description was prepared by the local consultant and governmental offices and is used in the office of DGIH.

(1) Ministry of Agriculture (MINAG)

*The Ministry of Agriculture (MINAG) is responsible for implementing programs and the Hydraulic Infrastructure General Direction (DGIH) is responsible for the technical administration of the programs. The Hydraulic Infrastructure General Direction (DGIH) is dedicated to the coordination, administration and supervision of investment programs.

- * In investment stage, the PSI(Programa Subsectorial de Irrigaciones, Ministerio de Agricultura) is dedicated to calculate project costs, detail design and supervision of the works execution.
- * The Planning and Investment Office (OPI) from the Agriculture Ministry is the one responsible for pre-feasibility and feasibility studies in the pre-investment stage of DGIH projects and requests approval of DGPI(previous DGPM) from the Economy and Finance Ministry (MEF).
- * The General Administration Office of the Agriculture Ministry (OGA-MINAG) along with the Public Debt National Direction (DGETP, previous DNEP) of the Economy and Finance Ministry is dedicated to financial management. It also manages the budget for procurement, commissioning works, contracting, etc. from the Agriculture Ministry.
- * The Environmental Affairs General Direction (DGAA) is responsible for reviewing and approving the environmental impact assessment in the investment stage.

(2) Economy and Finance Ministry (MEF)

- * The DGPI approves feasibility studies. It also confirms and approves the conditions of loan contracts in yen. In the investment stage, it gives technical comments prior to the project execution.
- * Financial management is in charge of DGETP (previous DNEP) from the Economy and Finance Ministry and OGA-MINAG.
- * The Public Debt National Direction DGETP (previous DNEP) of the Economy and Finance Ministry administers expenses in the investment stage and post-investment operation.

(3) Irrigation Commission

- * Responsible for the operation and maintenance of facilities at the post-investment operation stage.

The relationship between the involved institutions in the Project's execution is shown in Figures 4.10-1 and 4.10-2.

In this Project, PSI from MINAG is scheduled to be the execution agency in the investment stage (Project execution). The PSI is currently performing JICA projects, etc. and in case of beginning a new project, it forms the correspondent Project Management Unit (PMU), and PSI is responsible of employment of international consultant with deep experience on Japanese Yen Loan project and carried out the detail design, procurement of contractor, and supervision of construction work etc. The following figure describes the structure of the different entities involved in the Project's execution stage. PMU is organized directly under PSI and the organization is as shown in the Figure-4.10-4.

The Agreement of Fund Transfer and Fund Management in the Figure-4.10-1 means MEF transferrs the fund to PSI and controls the expenditure.

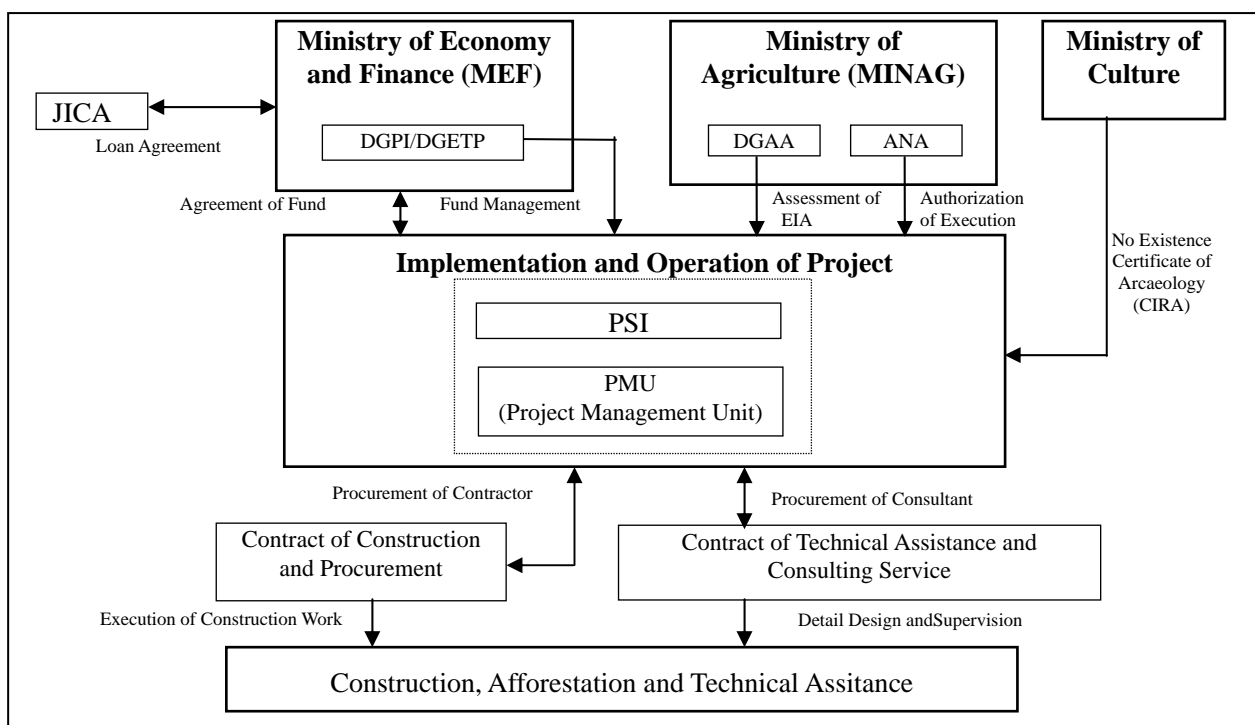

Figure 4.10-1 Related agencies in implementation stage of project

The main operations in the post-investment stage consist of operation and maintenance of the built works and the loan reimbursement. The O & M of the works will be assumed by the respective irrigation commission. Next, the relationship of different organizations involved in post-project implementation stage is detailed.

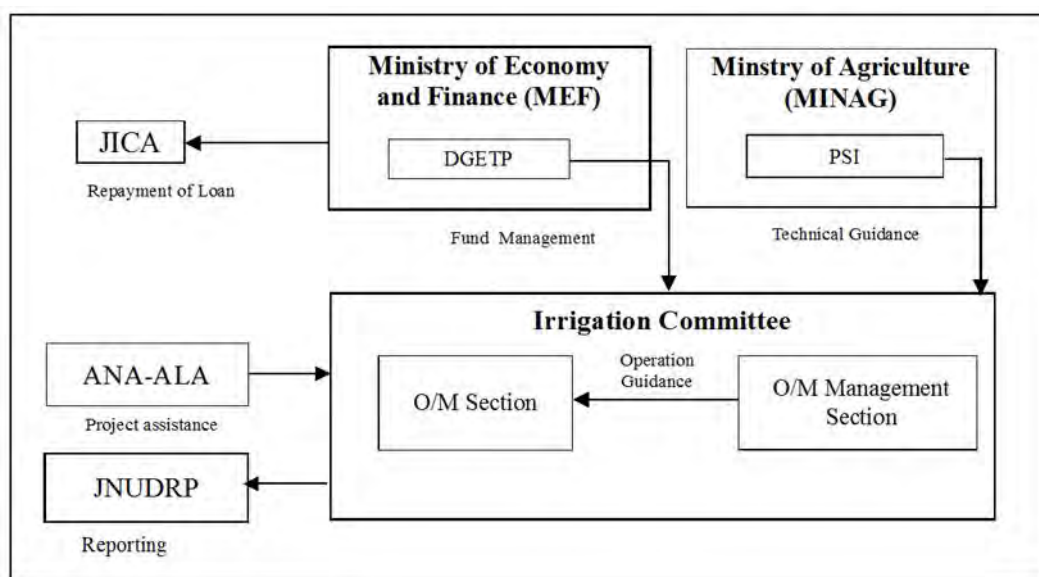

Figure 4.10-2 Related agencies in operation stage of project

(1) DGIH

1) Role and functions

The Hydraulic Infrastructure General Direction is in charge of proposing public policies, strategies and plans aimed to promoting water infrastructure development, according with the Water Resources National Policy and the Environmental National Policy.

Water Infrastructure development includes studies, works, operation, maintenance and construction risk management, fit-out, improve and expand dams, intakes, river beds, irrigation channels, drains, meters, outlets, groundwater wells and modernize plot irrigation.

2) Main functions

- a) Coordinate with the planning and budget office to develop water infrastructure and propose sectorial and management policies on infrastructure development. Monitor and assess the implementation of sectorial policies related to hydraulic infrastructure development
- b) Propose government, region and provinces intervention regulations, as part of sectorial policies
- c) Verify and prioritize hydraulic infrastructure needs
- d) Promote and develop public investment projects at the hydraulic infrastructure profile level
- e) Elaborate technical regulations to implement hydraulic infrastructure projects
- f) Promote technological development of hydraulic infrastructure
- g) Elaborate operation and maintenance technical standards for hydraulic infrastructure

(2) PSI

1) Function

The Irrigation Sub-sectorial Program (PSI) is responsible of executing investment projects. A respective management unit is formed for each project.

2) Main functions

- a) Irrigation Sub-sectorial Program - PSI, under the Agriculture Ministry, is a body with administrative and financial autonomy. It assumes the responsibility of coordinating, managing and administering involved institutions in projects in order to meet goals and objectives proposed in investment projects
- b) Also, it coordinates the disbursements of foreign cooperation agencies financing, such as JICA.
- c) The Planning, Budget and Monitoring Office of PSI is responsible for hiring services, elaborating investment programs, as well as project execution plans. These Project preparation works are executed by hiring “in-house” consultants.
- d) Likewise, it gathers contractors, makes a lease, executes works and implements supply projects, etc.
- e) Contract management is leaded by the Planning, Budget and Monitoring Office

3) Budget

In Table 4.10-1 the PSI budget for 2011 is shown.

Table 4.10-1 PSI budget (2011)

Programs / Projects / Activities	PIM (S/.)
JBIC Program (Loan Agreement EP-P31)	69.417.953
Program - PSI Sierra (Loan Agreement 7878-PE)	7.756.000
Direct management works	1.730.793
Southern Reconstruction Fund (FORSUR)	228.077
Crop Conversion Project (ARTRA)	132.866
Technified Irrigation Program (PRT)	1.851.330
Activity- 1.113819 small farmers...	783.000
PSI Management Program (Other expenses)	7.280.005
TOTAL	89.180.024

4) Organization

PSI is confirmed by 235 employees, from which 14 are assigned for JBIC Projects and 29 technicians and assistants are working under them.

Table 4.10-2 PSI payroll

Central Level	Data from May 31, 2011		
	CAS	Servic. and Consult.	TOTAL
Main Office	61	43	104
Zonal Office LIMA	12	24	36
Zonal Office AREQUIPA	14	12	26
Zonal Office CHICLAYO	17	13	30
Zonal Office TRUJILLO	13	26	39
TOTAL	117	118	235

In Figure 4.10-3, PSI organization is detailed:

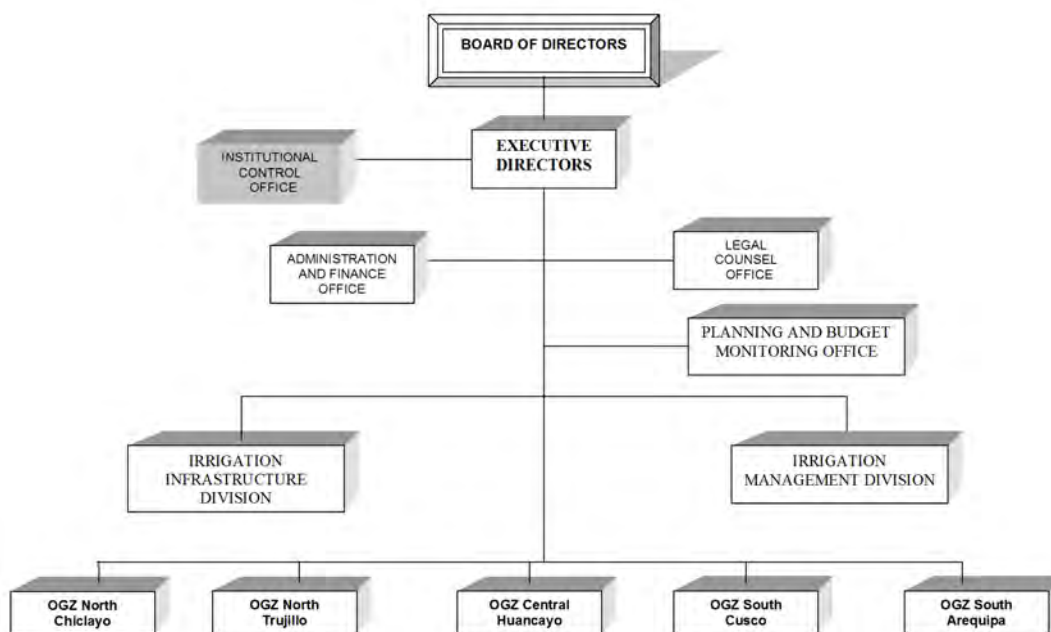
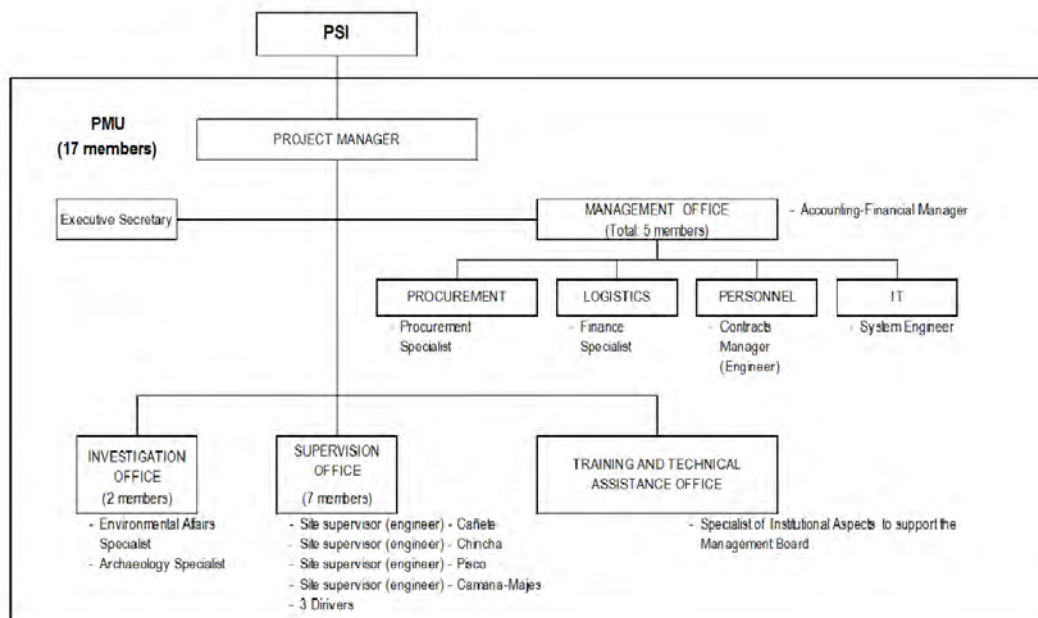

Figure 4.10-3 Organization of PSI

(3) Organization of PMU (Project Management Unit)

1) Organization

PMU is installed directly connected the Irrigation Infrastructure Division of PSI. The organization of PMU is as shown in the Figure 4.10-4.



Note: () shows number of personnel

Figure 4.10-4 Organization of PMU

2) Main staff

PMU is composed of the following main staff.

- Project manager
- Contract specialist
- Construction supervisor
- IT specialist
- Procurement specialist
- Financial specialist
- Organization specialist (Adviser to the irrigation committee)
- Environmental assessment specialist
- Archeological specialist
- Accountant

3) Cost

The cost for operation of PMU is budgeted at 8.5 million soles as described in the clause 4.4.1, Table 4.4.1-11. The Project will be promoted safely, by installing PMU in the implementation agency PSI and receiving the assistance of the consultant procured separately.

4.11 Execution plan

The Project's Execution Plan will be examined in the preliminary schedule, which includes the following components. For pre-investment stage: ① full execution of profile and feasibility studies to obtain SNIP's approval in the pre-investment stage; for the investment stage: ② signing of loans (L/A), ③ consultant selection, ④ consulting services (detailed design and elaboration of technical specifications), ⑤ constructor selection and ⑥ work execution. For the post-investment stage: ⑦ Works' completion and delivery to water users associations and beginning of the operation and maintenance stage.

(1) Review by the Public Investment National System (SNIP)

In Peru, the Public Investment National System (SNIP hereinafter) is under operation. This reviews the rationality and feasibility of public investment projects, and will be applied to this Project.

In SNIP, among previous studies to an investigation, it will be conducted in 3 stages: profile study (study on the project's summary), pre-feasibility and feasibility. SNIP was created under Regulation N° 27293 (published on June 28, 2000) in order to achieve efficient use of public resources for public investment. It establishes principles, procedures, methods and technical regulations to be fulfilled by central/regional governments in public investment scheme plans and executed by them. SNIP, as described below, is all public works projects which are forced to perform a 3-stage pre-investment study: profile study, pre-feasibility and feasibility, and have them approved. However, following the Regulation amendment in April 2011, the execution of pre-feasibility study of the intermediate stage was considered unnecessary; but in return, a study based on primary data during the profile study is

requested. The required precision degree throughout all stages of the study has hardly changed before and after this modification.

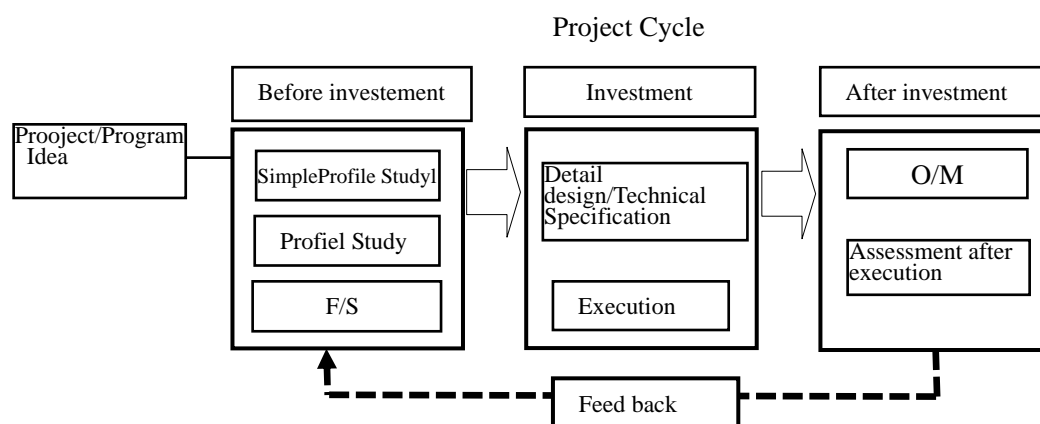

(Source : DGPI)

Figure 4.11-1 SNIP project cycle

In order to carry out this Project, which is a project composed by several programs, pre-investment studies at investments' programs level are required to be performed and also have them approved. Although the procedure is a little bit different in each stage, in SNIP procedures, the project's formulation unit (UF) conducts studies of each stage, the Planning and Investment Office (OPI) assesses and approves the UF's presented studies and requests Direction General of Investment Policy (hereinafter referred to DGPI) to approve feasibility studies and initiation of following studies. Finally DGPI evaluates, determines and approves the public investment's justification.

Central government/Local government		MEF
UF (Formulator Unit)	OPI	DGPI
① Implementation of Profile and Feasibility studies ② Improvement of studies upon comments by OPI and DGPI	① Assessment of each study ② Approval of studies ③ Request DGPI's approval of next step study	① Approval of each study results

(Directiva No. 001-2009-EF/68.01)

Figure 4.11-2 Related institutions to SNIP

Due to the comments of examining authorities (OPI and DGPI) to UF, it will be necessary to prepare correspondent responses and improve the studies. Since these authorities officially admit applications after obtaining definitive answers, there are many cases in which they take several months from the completion of the study report until the completion of the study.

It is important to obtain well recognition of the contents and effectiveness of the project, for which UF is required to present the effect of project from the view point of study, design, construction plan as well as public investment and operation in continuity of the project. The study of natural conditions, planning of facilities, cost estimate, financial analysis etc. and also the table of contents of the study report should follow the regulation of SNIP.

DGIH registered Chincha river to SNIP on July 21, 2011 based on the Project Report of Chincha river.

OPI had examined project reports with pre-F/S level of Chincha river from the end of July and issued their comments on September 22, 2011. DGIH revised the reports of Chincha, river, and submitted to OPI in May 2012. OPI transferred the revised report to DGPI with its comments in July 2012 and DGPI approved the proceed to F/S with its comments in October 2012.

(2) Yen loan contract

Once the feasibility report of this Project is submitted, then the OPI and DGPI examine the contents of report, and finally the declaration of viability of the Project is to be issued by DGPI. When the declaration of viability is almost confirmed, the appraisal mission of JICA is dispatched and the negotiation of loan agreement is commenced and Loan Agreement (LA) is concluded. The period of negotiation period is assumed about 6 months.

(3) Procedure of the project's execution

After the documents are assessed by SNIP and a loan agreement between Japan (JICA) and the Peruvian counterpart is signed, a consultant will be selected. The consulting service includes the detailed design and technical specifications, the contractors' selection and the work's supervision. Next find the required time for each process. Table 4.11-1 presents the Project's overall schedule (As to the details of construction time schedule, refer to Annex-9 Construction Planning and Cost Estimate).

- 1) Consultant selection: 10 months
- 2) Detailed design and technical specifications of the work: 6 months
- 3) Contractor selection: 15 months
- 4) Construction supervision by Consultant on river structures and plantation along river structures: 24 months
- 5) The afforestation along river structures is carried out in parallel with the construction.
- 6) Disaster prevention education/Capacity development is carried out from time to time in parallel with construction work.

Table 4.11-1 Implementation plan

Item	2010			2011			2012			2013			2014			2015			2016			2017			2018			Months
	3	6	9	12	3	6	9	12	3	6	9	12	3	6	9	12	3	6	9	12	3	6	9	12	3	6	9	
1 Profile Study/SNIP Appraisal	Study			Appraisal																					28			
2 Feasibility Study/SNIP Appraisal	Study			Appraisal																					27			
3 Loan Appraisal																									6			
4 Selection of Consultant																									10			
5 Project Management Unit																									45			
6 Consulting Services																									45			
1) Detailed Design																									6			
2) Tender Preparation, Assistance																									15			
3) Supervision																									24			
7 Selection of Contractor, Contract																									15			
8 Implementation																												
1) Structural Measures																									24			
2) Vegetation																									24			
3) Disaster Education/Capacity Building																									24			
4) Land Acquisition																									27			
9 Completion/Inauguration																									-			

(4) Procurement

1) Employment of consultants

The employment of consultant is to be made according the following itmes:

- ① The consultants should be active in international market and have enough qualification and experience.
- ② The consultants are to have efficiency, transparency and non-discrimination among eligible consultants
- ③ The selection procedure should be taken in accordance with the stipulation in the Loan Agreement and the guideline for the Employment of Consultants under Japanese ODA Loans prepared by JICA

2) Procurement of contractor

The procurement of contractors is to be made according to the following items:

- ① The procurement of contractors is to be made using due attention to consideration s of economy, efficiency, transparency and non-discrimination among eligible bidders.
- ② The procurement procedure should be taken in accordance with the stipulation in the Loan Agreement and the guideline for the Employment of Consultants under Japanese ODA Loans prepared by JICA
- ③ The International Competitive Bidding: ICB is to be applied.
- ④ The pre-qualification (PQ) of bidders is to be applied in order to confirm the technical and financial capability of bidders. The following items are to be considered in PQ: a) experience of and past performance on similar contracts, b) capabilities with respect to personnel, equipment and plant, c) financial position.

4.12 Financial Plan

(1) Sharing ratio of project cost

This project will be implemented by the central government (through the DGIH), irrigation committees and regional governments. Also, the project cost will be covered with the respective contributions of the three parties.

As to the sharing ratio among the central government, regional government and irrigation committee, DGIH reported that in some dam project the ratio among the central government, regional government , local government and irrigation committee is 50%, 30%, 10% and10% respectively and JICA Peru office reported that in some irrigation project, the irrigation committee bore 20 %. However there are no such examples as the flood protection project of this Project

Considering the direct benefit received by the irrigation committee is not so much as in the irrigation project, the sharing percentage will be determined through discussions among stake holders, the ratio is assumed provisionally 80% for the central government (in this case MINAG), 15% for regional government and 5% for irrigation committee. And the final ratio will be determined through

negotiation among 3 parties.

(2) Financial plan

The total project cost is 239,474 thousand soles and Japan yen loan amount is 64,750 thousand soles (25,000 thousand US\$) so that the counter fund to be borne by Peru side is 174,724 thousand soles (=239,474 – 64,750).

The counter fund is divided into stakeholders as shown in the Table 4.12-1. The contribution of regional government and irrigation committee is distributed in proportion of project cost of each basin.

Table 4.12-1 Financial plan at implementation of project

(thousand soles)

	Item		Amount	Remarks
1	Project cost	①	239,474	
2	Yen loan	②	64,750	25millionUS\$x2.59
	Counter fund	③	174,724	①–②
3	Central government	④	139,779	③x80%
4	regional government	⑤	26,209	③x15%
	(1) Lima (canete)	⑥	3,355	⑤x12.8%(Ratio of Project Cost)
	(2) Ica (Chincha)	⑦	5,347	⑤x20.4%(Ratio of Project Cost)
	(Pisco)	⑧	7,548	⑤x28.8%(Ratio of Project Cost)
	Subtotal	⑨	12,895	⑦+⑧
	(3) Arequipa (Majes-Camana)	⑩	9,959	⑤x38.0%(Ratio of Project Cost)
5	Irrigation committee	⑪	8,736	③x5%
	(1) Canate	⑫	1,118	⑪x12.8%(Ratio of Project Cost)
	(2) Chincha	⑬	1,782	⑪x20.4%(Ratio of Project Cost)
	(3) Pisco	⑭	2,516	⑪x28.8%(Ratio of Project Cost)
	(4) Majes-Camana	⑮	3,320	⑪x38.0%(Ratio of Project Cost)

Note) 1 US \$ = 83,6 yen = 2,59 soles, 1 sol = 32,3 yen

(3) Repayment of loan

The yen loan shall be repaid according to the conditions stipulated in the Loan Agreement which is estimated as shown in the Table 4.12-2. The repayment will be made by the stakeholders according to the sharing ratio including the interest of loan.

Table 4.12-2 Estimated conditions of Japan Yen Loan

Interest	1.70%
Commitment Charge	0.10%
Maturity Period	25 years
Grace Period	7 years

4.13 Logical Framework of the Eventually Selected Option

In Table 4.12-1 the logical framework of the definite selected option is shown.

Table 4.13-1 Logical framework of the definite selected option

Narrative Summary	Verifying Indicators	Verifying Indicators Media	Preliminary Conditions
Superior Goal			
Promote socioeconomic local development and contribute in communities' social welfare.	Improve local productivity, generate more jobs, increase population's income and reduce poverty index	Published statistic data	Socio-economic and policy stability
Objectives			
Relief the high vulnerability of valleys and local continuity to floods	Types, quantity and distribution of flood control works, population and beneficiaries areas	Monitoring annual calendar works and financial plan, budget execution control	Ensure the necessary budget, active intervention from central and regional governments, municipalities, irrigation communities, local population, etc.
Expected results			
Reduction of number and flooded areas, functional improvement of intakes, irrigation channels protection, bank erosion control	Number of areas and flooded areas, water intake flow variation, bank erosion progress	Site visits, review of the flood control plan and flood control works reports and periodic monitoring of local inhabitants	Maintenance monitoring by regional governments, municipalities and local community, provide timely information to the superior organisms
Activities			
Component A: Structural Measures	Dikes rehabilitation, intake and bank protection works construction of 23 works, including dike's safety	Detailed design review, works reports, executed expenses	Ensure the works budget, detailed design/works execution/good quality works supervision
Component B: Non-Structural Measures (Reforestation and vegetation recovery)	Reforested area, coastal forest area	Works advance reports, periodic monitor by local community	Consultants support, NGO's, local community, gathering and cooperation of lower watershed community
Component C: Disaster prevention and capabilities development education	Number of seminars, trainings, workshops, etc.	Progress reports, local governments and community monitoring	Predisposition of the parties to participate, consultants and NGO's assessments
Project's execution management			
Project's management	Detailed design, work start order, work operation and maintenance supervision	Design plans, work's execution plans, costs estimation, works specifications, works management reports and maintenance manuals	High level consultants and contractors selection, beneficiaries population participation in operation and maintenance

4.14 Baseline for Impact Assessment

The indicators of impact assessment are as shown below.

- Scale of flood discharge
- Inundation area
- Damage caused by flood
- Environment impact
- Operation and maintenance cost

1) Scale of flood discharge

As to the flood which causes the damage, the flood discharge is to be estimated using the rainfall and discharge observation data. Since the probable flood discharges were estimated in each basin in this Study, the occurrence probability of actual flood could be estimated and the impact given by the flood could be assessed.

2) Inundation area

The inundation caused by the actual flood is to be plotted on the topographical map or satellite figure so that the inundation area around flood prevention facilities can be identified. Since the inundation area corresponding to the probable flood was estimated in the this Study, this area can be compared with the actual inundation area and the impact given by the actual inundation can be assessed.

3) Flood damage

The actual flood damage is to be estimated for crops, loss of farm land, irrigation facilities, intake, traffic interruption, and other indirect damage. The actual damage can be compared with the damage caused by the probable flood. The impact caused by the actual damage can be assessed.

4) Environment impact

In the operation and maintenance stage, the environment impact is to be assessed regularly using the same method in this Study. The results are to be compared with the original results, then the environmental impact of the project can be assessed.

5) Operation and maintenance cost

The operation and maintenance cost of the Project was estimated in this Study. The actual O/M cost incurred to the irrigation committee is monitored in every year. The actual cost is to be compared with the estimated and the impact on O/M cost can be assessed.

4.15 Middle and Long Term Plan

Up to this point, only flood control measures have been proposed and these must be executed most urgently, due to the limitations on the available budget for this Project. However, there are other measures that must be performed in the long term framework. In this section we will be talking about the middle and long term flood control plan.

4.15.1 Flood Control General Plan

There are several ways to control floods in the entire watershed, for example building dams, reservoirs, dikes or a combination of these.

In case of building a dam proposal, assuming that this dam will reduce the flood peak with a 10 year return period reaching a return period flow of 50 return years, it will be necessary to build a dam with a very big capacity, calculating it in 48.6 million m³ for Chincha River. Usually upstream of an alluvial area, there is a rough topography in order to build a dam, a very high dam will be required to be built, which implies investing a large amount (more than thousand millions of soles).

Also, it would take between three to five years to identify the dam site, perform geological survey, material assessment and conceptual design. The impact on the local environment is huge. So, it is considered inappropriate to include the dam analysis option in this Study.

Likewise, the option of building a retarding basin would be hardly viable for the same reasons already given for the dam, because it would be necessary to build a great capacity reservoir and it is difficult to find a suitable location because most of the flat lands along the river's downstream are being used for agricultural purposes. So, its analysis has been removed from this Study. Therefore, we will focus our study in the construction of dike because it is the most viable option.

(1) Plan of the river course

1) Discharge capacity

An estimation was done on the discharge capacity of the current flow of this river based on longitudinal and cross sectional survey of the river, which results are shown in the section 3.1.10, Figure 3.1.10-3 and Figure 3.1.10-4.

2) Inundation characteristics

The inundation analysis of Chincha river was performed. In the section 3.1.10, Figure 3.1.10-5 and in Figure 3.1.10-6 the inundation condition for flood with probabilities of 50 years is shown.

The right tributary, Chico River, overflows on km 15 and km 4 sections, from the mouth. This floods vast extensions of left bank. Likewise, left tributary, Matagente, overflows on km 10 and km 4, from the mouth. This floods vast extensions of right bank.

3) Design flood level and dike's standard section

The design flood level was determined in the flood water level with a return period of 50 years applying the standard section of dike already mentioned in section 4.3.1, 5), 3) to the present river channel. In the Table 4.2-2 and Table 4.2-3 the theoretical design flood level and the required height of the dike's crown is shown.

4) Dikes' alignment

Considering the current conditions of existing dikes the alignment of the new dikes was defined. Basically, the broader possible river width was adopted to increase the discharge capacity and the retard effect. In Figure 4.15.1-1 the current channel and the setting alignment method of a section

where the current channel has more width is explained schematically. In a normal section, the dike's crown has the same height to the flood water level with a return period of 50 years plus free board, while in the sections where the river has greater width, double dikes be constructed with inner consistent dike alignment and continuous with normal sections upstream and downstream. The crown height is equal to the flood water level with a return period of 50 years. The external dike's crown height is equal to flood water level with a return period of 50 years, so in case the river overflows the internal dike, the open gap between the two dikes will serve to store sediments and retarding water.

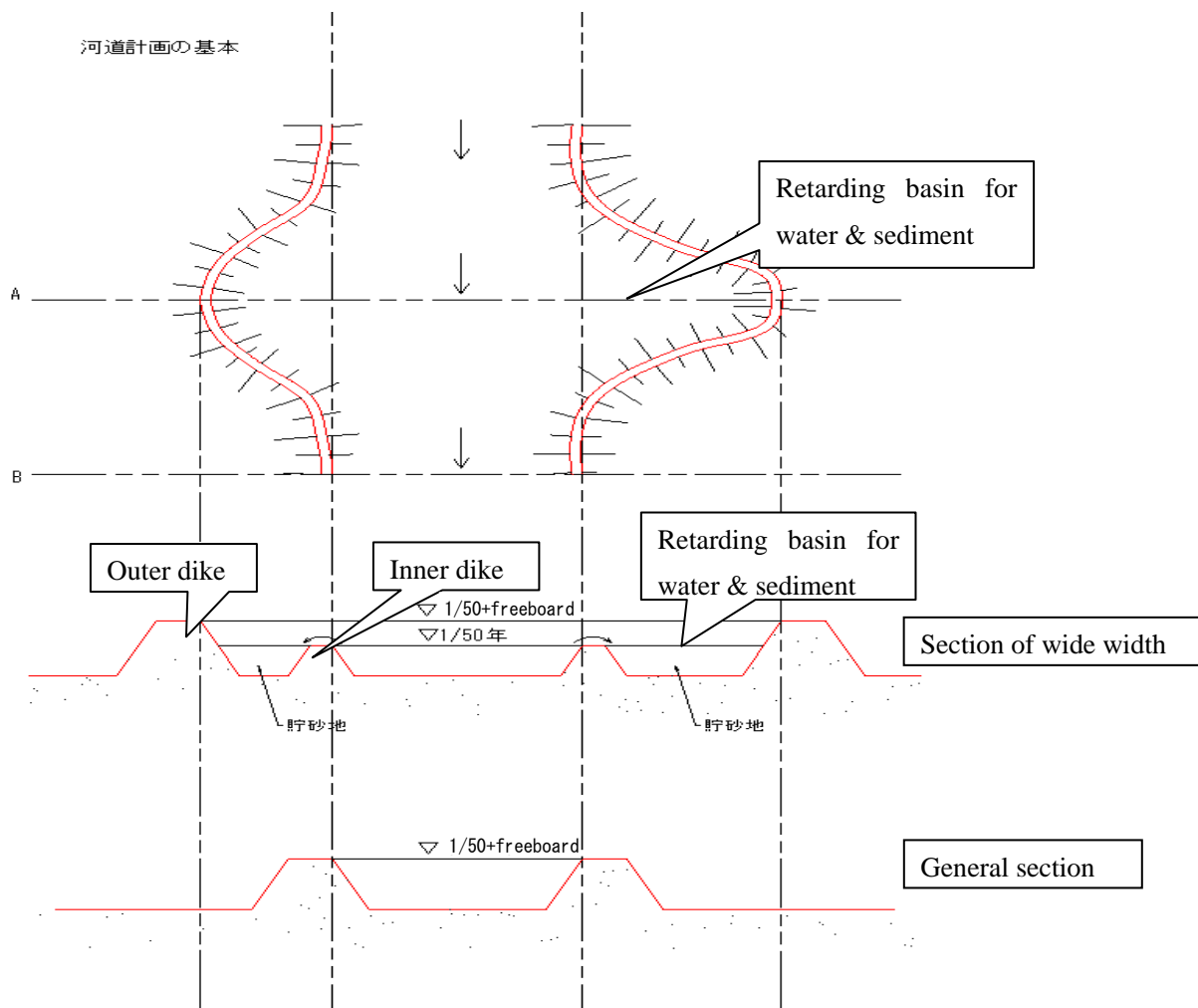

Figure 4.15.1-1 Definition of dike alignment

5) Plan and section of river

The plan and longitudinal section of river are as shown in the Figure 4.15.1-2, and -4.15.1-3 and Figure 4.15.1-4 respectively.

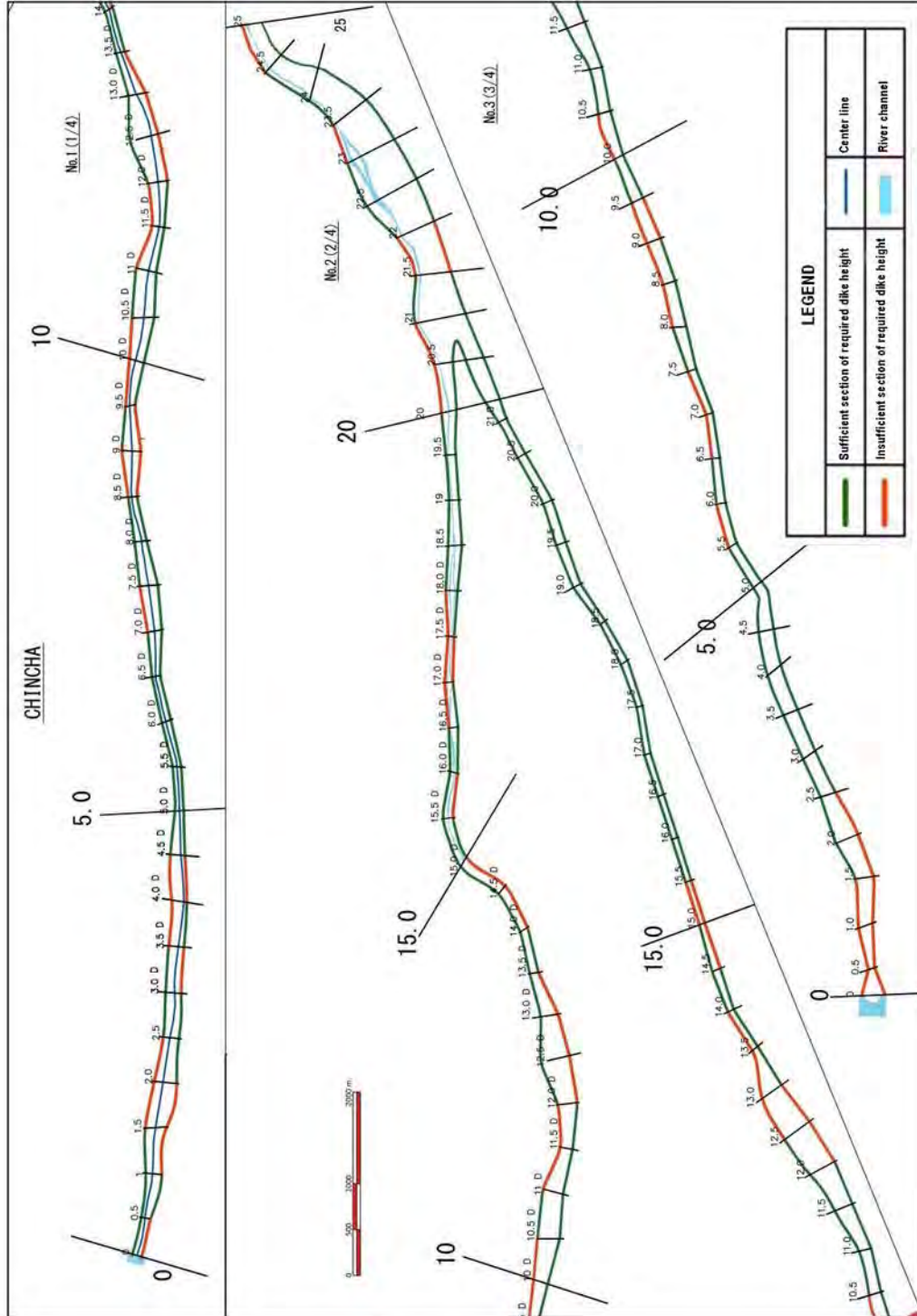

Figure 4.15.1-2 Plan of Chincha river

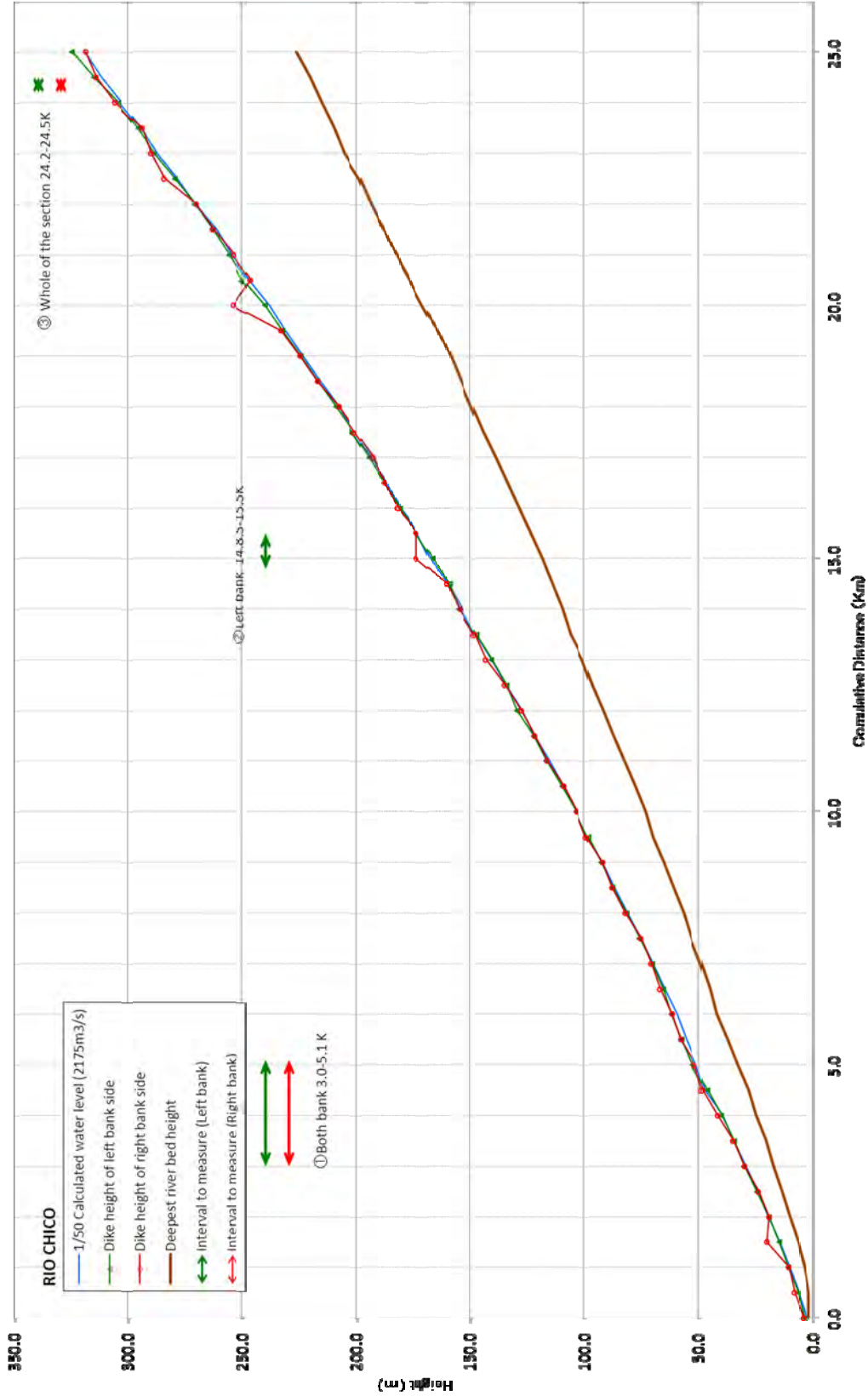

Figure 4.15.1-3 Chincha river longitudinal profile (Chico river)

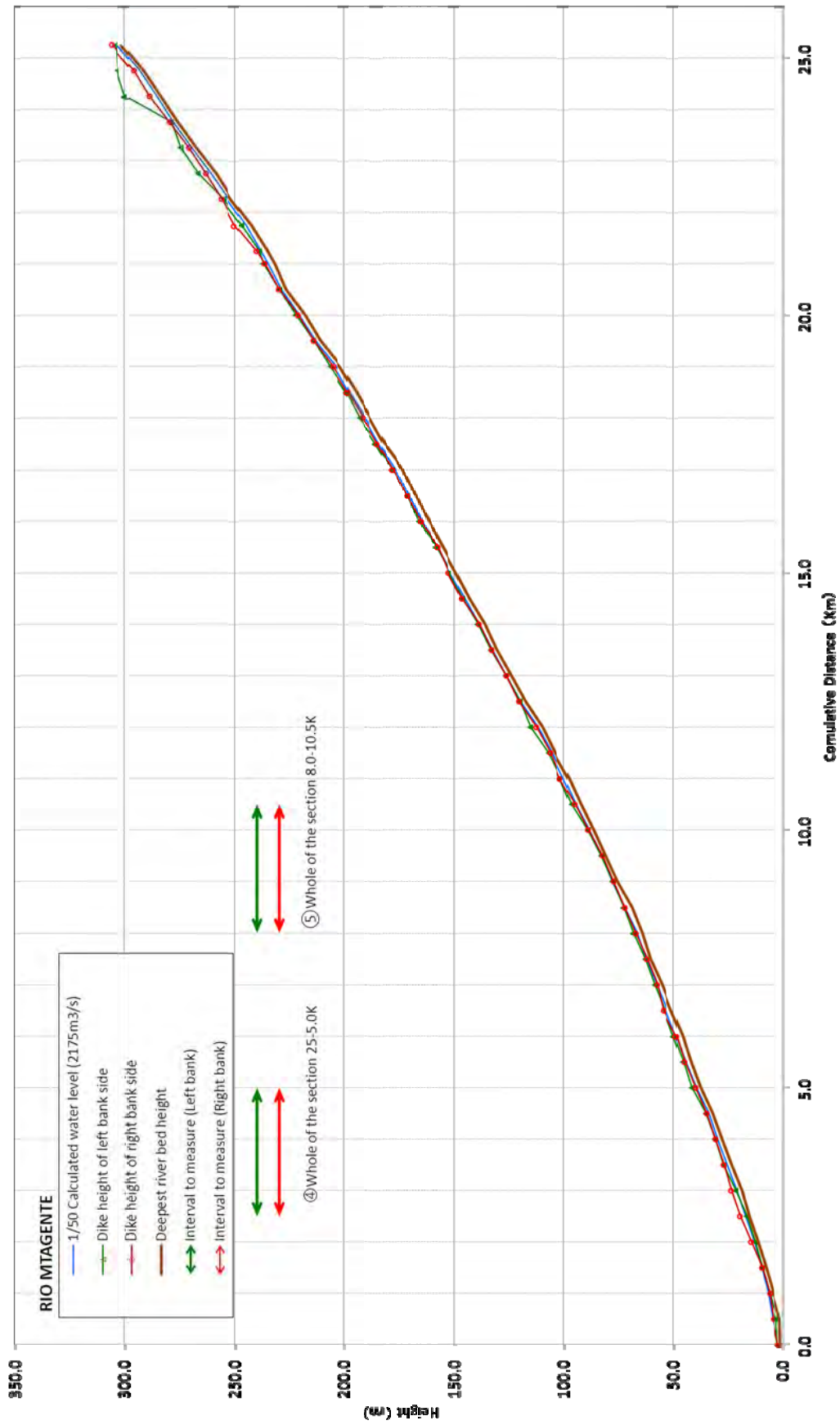

Figure 4.15.1-4 Chincha river longitudinal profile (Matagente river)

6) Dike's construction plan

Next, basic policies for the dike's construction plan on the Chincha River are shown:

- Build dikes that allow flood flow safe passage with a return period of 50 years
- The dikes will be constructed in areas where overflowing water will enter the dike, according to the flood simulation
- The dikes will be placed in the sections above mentioned, where the design water level exceeds the existing dike's height or the ground level within the dike
- The dike's height is defined in the flood water level with a return period of 50 years plus the free board

Table 4.15.1-1 and Figure 4.15.1-5 and Figure 4.15.1-6 show the dike's construction plan on the Chincha River

Table 4.15.1-1 Dike's construction plan

River	Sections to be improved		Dike missing height average (m)	Dike proposed size	Dike length (km)
Chincha	Left margin	0,5k-17,5k	0,56	Dikes' height = 1,5m Margin protection works height = 3,0m	7,0
	Right margin	2,0k-18,0k	0,53		5,5
	Total		-		12,5
	Left margin	0,5k-15,5k	0,58		7,5
	Right margin	0,0k-15,5k	0,55		13,0
	Total		0,56		25,5

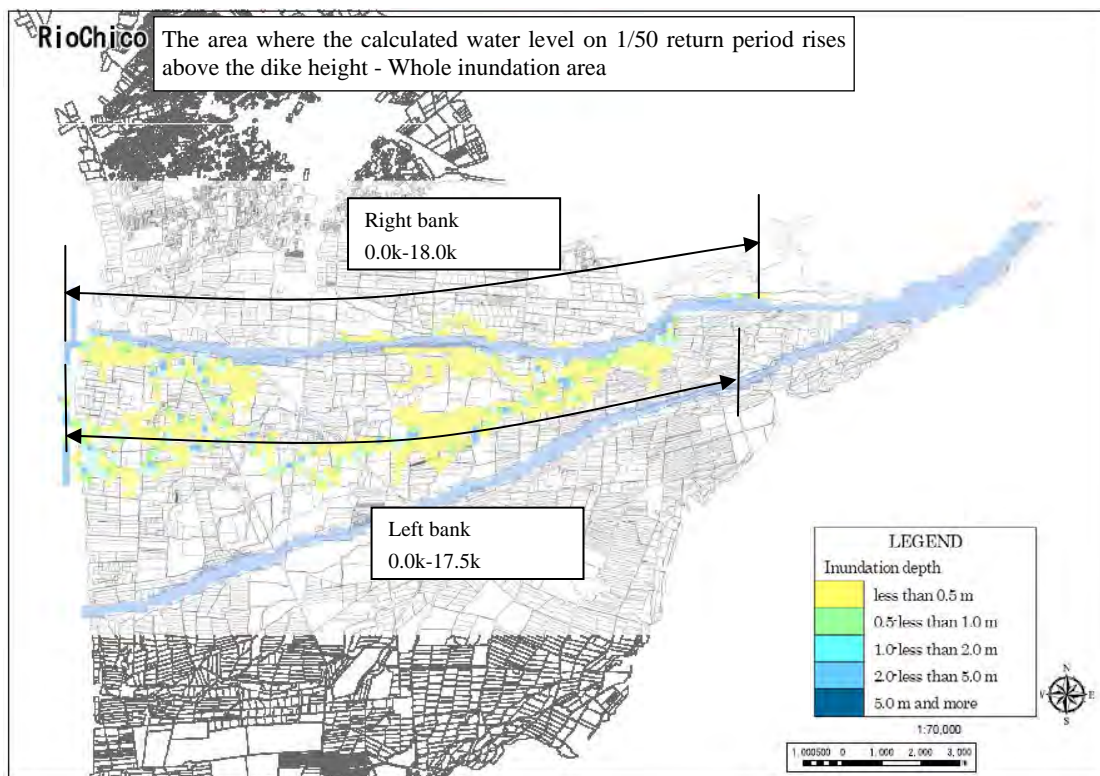

Figure 4.15.1-5 Layout of dike in Chincha river (Chico river)

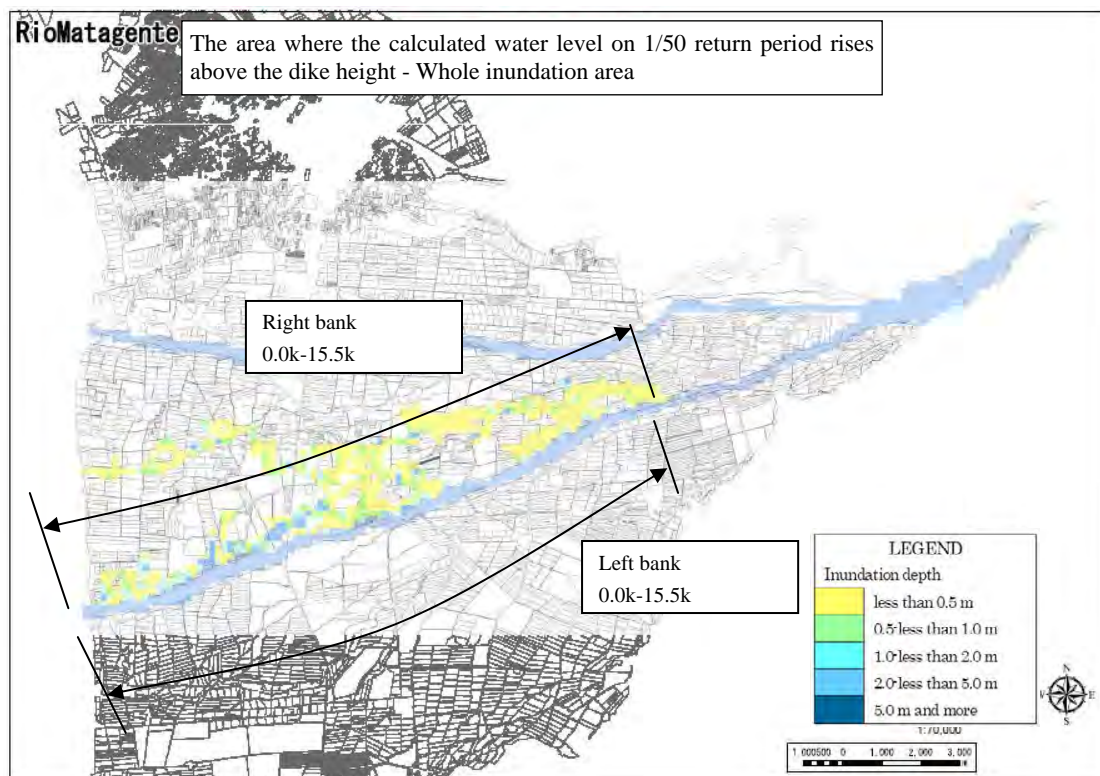

Figure 4.15.1-6 Layout of dike in Chincha river (Matagente river)

7) Project cost

In Tables 4.15.1-2 and 4.15.1-3 works' direct costs in private prices and the Project's cost are shown. Also, the cost of the project in social prices is presented in Table 4.15.1-4.

Table 4.15.1-2 Works direct cost (at private prices)

Di ke bui l di ng				Coastal defense			
B1	H1	B2	A	B1	H2	B2	A
3.0	1.0	8.5	5.8	1.0	1.0	2.4	10.8
3.0	2.0	14.0	17.0	1.0	2.0	2.9	13.4
3.0	3.0	19.5	33.8	1.0	3.0	3.4	16.5
3.0	4.0	25.0	56.0	1.0	4.0	3.9	20.1
3.0	5.0	30.5	83.8	1.0	5.0	4.4	24.3
3.0	1.5	11.3	10.7	1.0	6.0	4.9	28.9
				1.0	1.5	2.6	12.0
				1.0	10.0	6.9	52.4

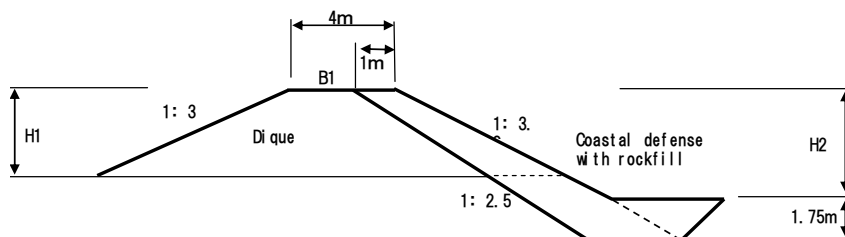

Wáter shed	Wórks	Amount	Unit	Unitary Price (in sol es)	Wórkdirect cost /m (in sol es)	Wórkdirect cost /km (in thousand sol es)	Dike length (k m)	Wórkdirect cost (in thousand sol es)
Chincha	Diques	10.7	m ³	10.0	107.0	107.0	25.5	2,728.5
	Protección de	16.5	m ³	100.0	1650.0	1,650.0		42,075.0
Total						1,757.0	1,757.0	44,803.5

Table 4.15.1-3 Projects' cost (at private prices)

Basin Name	Direct Cost			Indirect Cost						Infrastructure Cost, Total Cost (12)=(8)+(9)+(10)+(11)		
	Direct Cost (1)	Temporary Construction Cost (2)	Total Direct Cost (3)=(1)+(2)	Overhead (4)=0.15x(3)	Profit (5)=0.1x(3)	Work Cost (6)=(3)+(4)+(5)	Tax (IGV) (7)=0.18x(6)	Total Construction Cost (8)=(6)+(7)	Environmental Cost (9)=0.01x(8)		Detail Design Cost (10)=0.05x(8)	Construction Supervision Cost (11)=0.1x(8)
CHINCHA	44,803,500	4,480,350	49,283,850	7,392,578	4,928,385	61,604,813	11,088,866	72,693,679	726,937	3,634,684	7,269,368	84,324,667

Table 4.15.1-4 Projects' cost (at social prices)

Basin Name	Direct Cost			Indirect Cost						Infrastructure Cost, Total Cost (12)=(8)+(9)+(10)+(11)		
	Direct Cost (1)	Temporary Construction Cost (2)	Total Direct Cost (3)=(1)+(2)	Overhead (4)=0.15x(3)	Profit (5)=0.1x(3)	Work Cost (6)=(3)+(4)+(5)	Tax (IGV) (7)=0.18x(6)	Total Construction Cost (8)=(6)+(7)	Environmental Cost (9)=0.01x(8)		Detail Design Cost (10)=0.05x(8)	Construction Supervision Cost (11)=0.1x(8)
PISCO	58,859,500	5,885,950	64,745,450	9,711,818	6,474,545	80,931,813	14,567,726	95,499,539	954,995	4,774,977	9,549,954	110,779,465

(2) Operation and Maintenance plan

The operation and maintenance cost was calculated identifying the trend of the sedimentation and erosion bed based on the one-dimensional analysis results of the bed variation, and a long-term operation and maintenance plan was created.

The current river course has some narrow sections where there are bridges, farming works (intakes, etc.) and there is a tendency of sediment gathering upstream of these sections. Therefore, in this project there is a suggestion to increase the hydraulic capacity of these narrow sections in order to avoid as possible upstream and in the bed (main part) sedimentation, together with gathering sediments as much as possible when floods over a return period of 50 years occur.

1) Riverbed fluctuation analysis

The summary of the riverbed fluctuation analysis model is as shown in the Table 4.15.1-5 and the analysis conditions are as shown in the Table 4.15.1-6.

The Figure 4.14.1-6 shows the results of the riverbed fluctuation analysis of the river for the next fifty years. From this figure a projection of the riverbed's sedimentation and scouring trend and its respective volume can be made.

Table 4.15.1-5 Summary of riverbed fluctuation analysis model

Items	Content
Water Flow	One-dimensional Non-uniform Flow Model
Sediment Transportation	One-dimensional Mixed Grain Size Riverbed Fluctuation Model
Bed Load	Ashida & Michiue' s Bed load formula
Suspended Load	Ashida & Michiue' s Suspended Load formula considering non-equilibrium of suspended sediment
Calculation Method	MacCormack Method

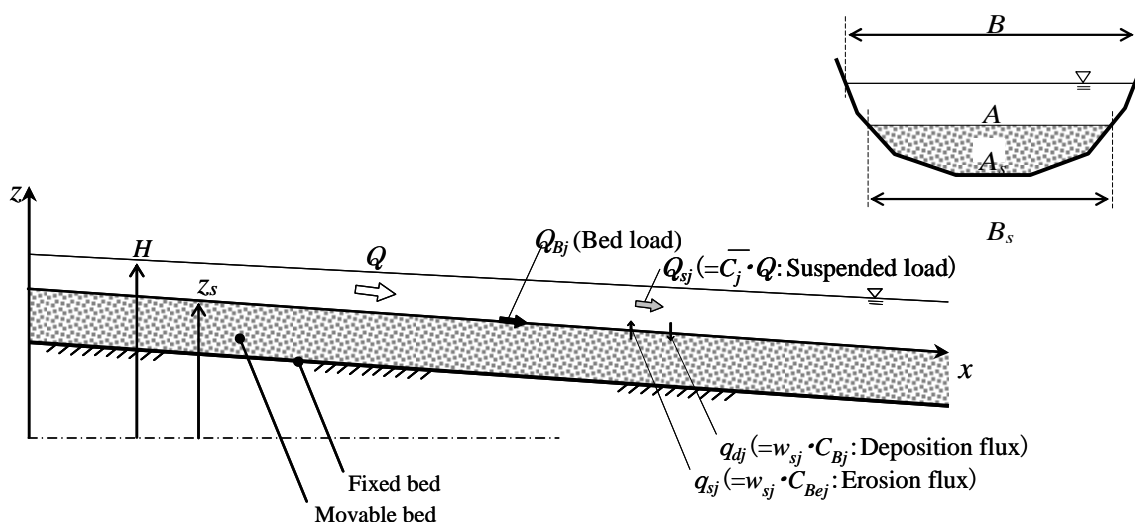

Figure 4.15.1-7 Pattern diagram of riverbed fluctuation analysis model

Table 4.15.1-6 Analysis condition of each river

	Chincha
Calculation river length	46.9km
Period	For future 50 years
Space interval (Δx)	100m
Time interval (Δt)	2.0sec
Input discharge	50 years discharge prepared based on observation data (max. annual discharge), in case of insufficient year number prepared by repeating the limited year data.
Sediment Supply	115,000m ³ /year
Tributary inflow	Disregarded since there are only small tributaries
Grain size	Based on the grain size distribution in the riverbed material, 8~ 9 grain size are assumed (d=0.075mm ~500mm) .
Water level at downstream end	Assumed normal water depth at the downstream end
Roughness coefficient	n=0.05 (all section)
Void ration	0.4 (representative value of sand and gravel)
Others	Calculated for Chico and Matagente rivers

2) Sections that need maintenance

In Table 4.15.1-7 possible sections that require a process of long-term maintenance in the Chincha River watershed is shown.

Table 4.15.1-7 Sections/places to be carried out maintenance works

River		Excavation extension		Maintenance method
Chincha River	(Chico)	Section 1	Section : 3,5km-4,5km Volume : 53.000m ³	It is a section where the water overflows. It is necessary to perform a periodic excavation in these sections because its bed will increase gradually in time.
	(Matagente)	Section 1	Section : 10,5km-13,5km Volume : 229.000m ³	
		Section 2	Section : 21,0km-23,5km Volume : 197.000m ³	It is a section likely to have sediments accumulation due to the river's width. It is necessary to perform periodic excavation because its bed will increase gradually in time with possibilities of overflowing

* Sediment volume that will gather in
50 year period

3) Operation and maintenance cost

Next the direct work cost at private prices for maintenance (bed excavation) required for the watershed in the next 50 years is shown.

Direct Work Cost

At private prices: $479,000 \text{ m}^3 \times 10 = 4,790,000$ soles

Tables 4.15.1-8 and 4.15.1-9 show a 50 year Project cost at private and social prices.

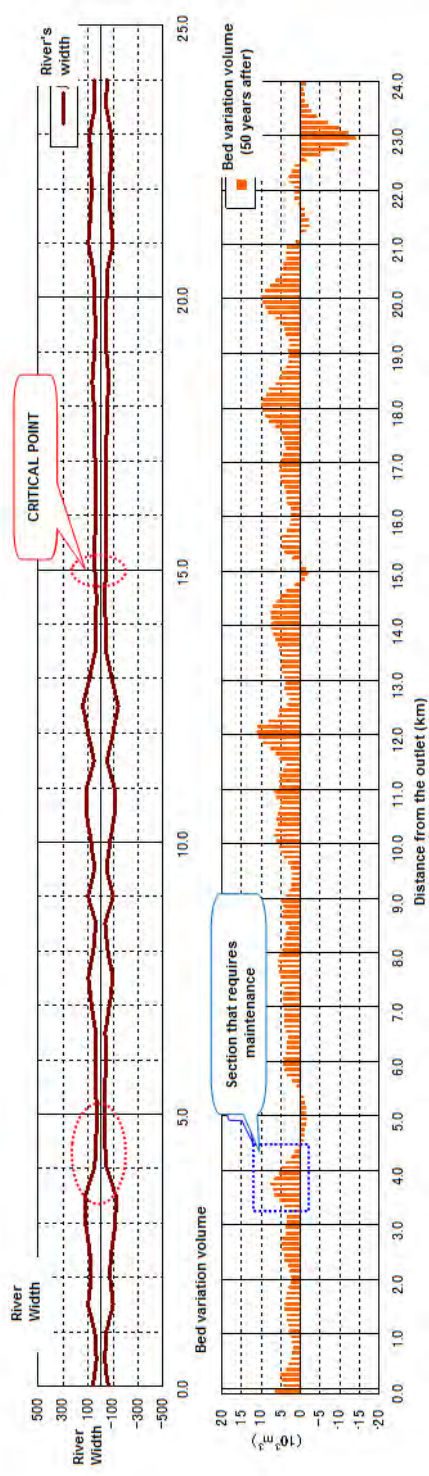

Figure 4.15.1-8 Section that requires maintenance (Chincha river - Chico)

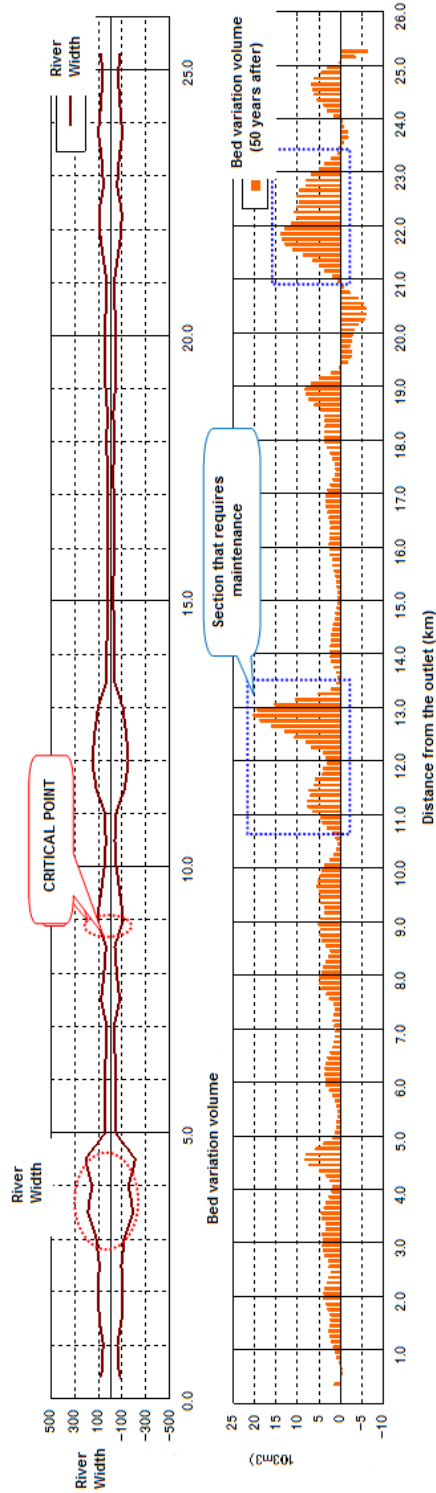

Figure 4.15.1-9 Section that requires maintenance (Chincha river - Matagente)

Table 4.15.1-8 Excavation works cost for a 50 year bed (at private prices)

Name of Watershed	Direct Cost	Temporal works cost	Works Cost	Operative Expenses	Utility	Infrastructure total cost	TAX	Work's Total Cost	Environmental Impact	Technical File	Supervision	Total Cost
流域名	直接工事費計	共通仮設費	工事費	諸経費	利益	構造物工事費	税金	建設費	環境影響	詳細設計	施工管理費	事業費
	(1)	(2) = 0.1 x (1)	(3) = (1) + (2)	(4) = 0.15 x (3)	(5) = 0.1 x (3)	(6) = (3)+(4)+(5)	(7) = 0.18 x (6)	(8) = (6)+(7)	(9)=0.01 x (8)	(10) = 0.05 x (8)	(11) = 0.1 x (8)	(12) = (8)+(9)+(10)+(11)
Chincha	4,790	479	5,269	790	527	6,586	1,186	7,772	78	389	777	9,015

Table 4.15.1-9 Excavation works cost for a 50 year bed (at social prices)

Name of Watershed	Direct Cost	Temporal works cost	Works Cost	Operative Expenses	Utility	Infrastructure total cost	TAX	Work's Total Cost	Environmental Impact	Technical File	Supervision	Total Cost	Supervision	Costo Total
流域名	直接工事費計	共通仮設費	工事費	諸経費	利益	構造物工事費	税金	建設費	環境影響	詳細設計	施工管理費	事業費	施工管理費	事業費
	(1)	(2) = 0.1 x (1)	(3) = (1) + (2)	(4) = 0.15 x (3)	(5) = 0.1 x (3)	(6) = (3)+(4)+(5)	(7) = 0.18 x (6)	(8) = (6)+(7)	(9)=0.01 x (8)	(10) = 0.05 x (8)	(11) = 0.1 x (8)	(12) = (8)+(9)+(10)+(11)	(12) = 0.1 x (9)	(13) = (9)+(10)+(11)+(12)
Chincha	4,790	479	5,269	790	527	6,586	1,186	7,772	0.804	6,249	62	312	625	7,248

(3) Social Assessment

1) Private prices cost

a) Damage amount

Table 4.15.1-10 shows the damage amount calculated analyzing the overflow caused by floods in the Chincha River with return periods between 2 and 50 years.

Table 4.15.1-10 Amount of damage for floods of different return periods (private prices)

(10³ Soles)

Year	Damage Amount
	Chincha
2	15,262
5	39,210
10	55,372
25	77,797
50	103,947
Total	291,588

b) Damage reduction annual average

Table 4.15.1-11 shows the damage reduction annual average of the watershed calculated with the data of Table 4.12.1-10.

c) Project's Cost and the operation and maintenance cost

Table 4.15.1-3 shows the projects' cost. Also, the annual operation and maintenance (O & M) cost for dikes and bank protection works can be observed in the table. This is calculated from the 0.5% of the construction cost plus the bed excavation annual average cost indicated in Table 4.15.1-6.

d) Economic evaluation

In Table 4.15.1-12 the results of economic assessment are shown.

Table 4.15.1-11 Damage reduction annual average

Basin	Return Period	Probability	Total Damage			Average Damage ④	Section Probability ⑤	Annual Average Damage ⑥=④×⑤	Accumulation of Annual Average Damage
			Without Project ①	With Project ②	Damage Reduction ③=①-②				
			(10 ⁶ Soles)						
CHINCHA	1	1.000	0	0	0			0	0
	2	0.500	15,262	0	15,262	7,631	0.500	3,816	3,816
	5	0.200	39,210	0	39,210	27,236	0.300	8,171	11,986
	10	0.100	55,372	0	55,372	47,291	0.100	4,729	16,715
	25	0.040	77,797	0	77,797	66,584	0.060	3,995	20,710
	50	0.020	103,947	0	103,947	90,872	0.020	1,817	22,528

Table 4.15.1-12 Economic assessment results (private prices costs)

流域名	年平均被害軽減額	評価期間被害 軽減額(15年)	事業費	維持管理費	B/C	NPV	IRR(%)
Basin	Annual Average Damage Reduction	Damage Reduction in Evaluation Period(15years)	Project Cost	O&M Cost	Cost Benefit Ration	Net Present Value	Internal Return of Rate
Chincha	292,863,416	132,251,314	84,324,667	7,429,667	1.71	55,091,224	21%

2) Social prices cost

a) Damage amount

Table 4.15.1-13 shows the damage amount calculated analyzing the overflow caused by floods in the Majes-Camana River with return periods between 2 and 50 years in each watershed.

Table 4.15.1-13 Amount of damage for floods of different return periods (at social prices)

Year	Damage Amount
	Chincha
2	16,758
5	44,275
10	74,539
25	101,437
50	133,108
Total	370,117

b) Damage reduction annual average

Table 4.15.1-14 shows the damage reduction annual average of each watershed calculated with the data of Table 4.15.1-13.

c) Project's Cost and the operation and maintenance cost

Table 4.15.1-4 shows the projects' cost. Also, the annual operation and maintenance (O & M) cost for dikes and margin protection works can be observed in the table. This is calculated from the 0.5% of the construction cost, as well as the bed excavation annual average cost indicated in Table 4.15.1-7.

d) Economic evaluation

In Table 4.15.1-15 the results of economic assessment are shown.

(4) Conclusions

The economic assessment result shows that the Project has positive economic impact in terms of cost on both private and social prices, but the required cost is extremely high (84.3 million soles), so that this Project is less viable to be adopted.

Table 4.15.1-14 Damage reduction annual average

Basin	Return Period	Probability	Total Damage			Average Damage ④	Section Probability ⑤	Annual Average Damage ⑥=④×⑤	Accumulation of Annual Average Damage
			Without Project ①	With Project ②	Damage Reduction ③=①-②				
			(10 ⁶ Soles)						
CHINCHA	1	1.000	0	0	0			0	0
	2	0.500	16,758	0	16,302	8,379	0.500	4,190	4,190
	5	0.200	44,275	0	39,416	30,517	0.300	9,155	13,345
	10	0.100	74,539	0	67,584	59,407	0.100	5,941	19,285
	25	0.040	101,437	0	82,505	87,988	0.060	5,279	24,565
	50	0.020	133,108	0	98,129	117,273	0.020	2,345	26,910

Table 4.15.1-15 Economic assessment results (social prices costs)

流域名	年平均被害軽減額	評価期間被害 軽減額(15年)	事業費	維持管理費	B/C	NPV	IRR(%)
Basin	Annual Average Damage Reduction	Damage Reduction in Evaluation Period(15years)	Project Cost	O&M Cost	Cost Benefit Ration	Net Present Value	Internal Return of Rate
Chincha	349,827,412	157,975,125	67,797,033	5,973,452	2.55	95,938,413	32%

4.15.2 Reforestation and Recovery of Vegetation Plan

(1) Reforestation of the upper watershed

Long-term reforestation in all areas considered to be critical of the upper watershed is recommended. So, a detail analysis of this alternative will be explained next.

1) Basic policies

- Objectives: Improve the water source area's infiltration capacity, reduce surface soils water flow and at the same time, increase water flow in intermediate soils and ground-water level. Because of the above mentioned, water flow is interrupted in high flood season, this increases water resources in mountain areas, reduces and prevents floods increasing with it the amount and greater flow of ground-water level, reducing and preventing floods

- Forestry area: means forestry in areas with planting possibilities around watersheds with water sources or in areas where forest area has decreased.
- Forestry method: local people plantations. Maintenance is done by promoters, supervision and advisory is led by NGOs.
- Maintenance after forestry: Maintenance is performed by the sow responsible in the community. For this, a payment system (Payment for Environmental Services) will be created by downstream beneficiaries.
- Observations: After each thinning the area will have to be reforested, keeping and preserving it in a long-term sustainable way. An incentive for community people living upstream of the watershed shall be designed.

The forest is preserved after keeping and reforesting it after thinning, this also helps in the support and prevention of floods. For this, it is necessary that local people are aware, encourage people downstream, promote and spread the importance of forests in Peru during the project's execution.

2) Selection of forestry area

As mentioned in 1) forestry of the upper watershed will be done with the help of the communities' labor, during their spare time from their agricultural activities. However, the community mostly lives in the highlands performing their farming and cattle activities in harsh natural conditions. Therefore, it is difficult to tell if they have the availability to perform forestry. So, finding comprehension and consensus of the inhabitants will take a long time.

3) Time required for the reforestation project

Since it is a small population, the workforce availability is reduced. So, the work that can be carried out during the day is limited, and the work efficiency would be very low. The JICA Study Team estimated the time required to reforest the entire area throughout the population in the areas within the reforestation plan, plant quantity, work efficiency, etc. According to this estimate, it will take 14 years to reforest approximately 40,000 hectares of Chincha River Watershed.

4) Total reforestation volume in the upper watershed and project's period and cost

The surface to be reforested for the Chincha River Watershed is a vast area (approx 44,000 ha), in years (14 years) and in investment amount (119.0 million soles).

Table 4.15.2-1 Upstream Watershed Forest General Plan

Watershed	Forestry Area (ha)	Required period for the project (years)	Required budget (soles)
Chincha	44.068,53	14	118.946.853

(Source: JICA Study Team)

5) Conclusions

The objective of this project is to execute the most urgent works and give such a long period for reforestation which has an indirect effect with an impact that takes a long time to appear would not be consistent with the proposed objective for the Project. Considering that 14 years and invested 119.0 million soles are required, we can say that it is impractical to implement this alternative in this project and that it shall be timely executed within the framework of a long-term plan after finishing this project.

(2) Reforestation model area

Select a model area of the upper watershed and reforestate the area as pilot project (this is an existing reforestation project of the Chincha river). In this watershed, the irrigation commission has been having discussions with communities of the upper watershed to preserve water approximately for 10 past years, achieving to date the consensus for its implementation with some communities. PRONAMACHCS (currently, AGRORURAL) has followed this concertation process and lead a forestry study plan of the Mountain region of the Huancavelica region. However, sadly, this initiative was held only on study stage without reaching any agreement due to lack of resources.

1) Configuration (tree disposition)

Tree disposition is usually adopted in Peru as triangle disposition. So, in this Project we are proposing to adopt this disposition keeping between trees an interval of 3 meters.

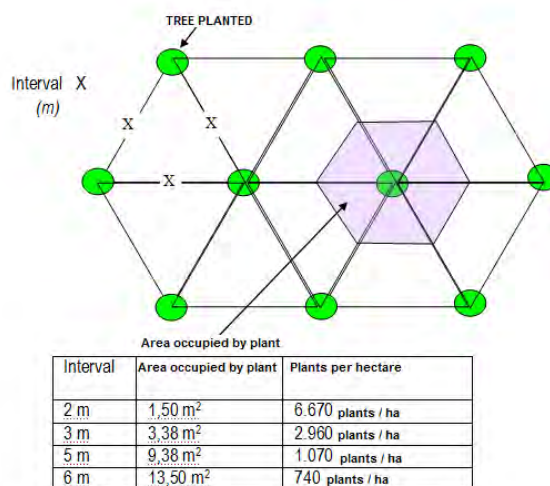

Figure 4.12.2-1 Standard reforestation map

2) Species to be used

The mostly used specie in the Mountain region of Peru is the eucalyptus and then Pine. Especially on altitudes over 4,000m.a.s.l pine is very common. Also, native species such as Quañua, Molle, Aliso, etc. can be found. However, due to the producers economic reasons predominant species are eucalyptus and pine. Tara is also used in the agro forestry sector, in case of prioritized case of effective income.

In general, reforestry is planned and implemented with local community consensus. In such case, apart from explaining about forest public interest, property of species, etc, also species to be planted are discussed and agreed. In AGRORURAL project, species to be used are selected by listening local community's opinions, which mostly all of them chose pine and queñua in relatively low altitudes. So in this project we will select the same species.

3) Reforesting plan volume and vegetation recovery

Currently, there are 44,068.53 ha to be reforested in the upper watershed of Chincha river. With aims of identifying the reforested area throughout the present project by reforesting volume within the established period, the following criteria shall be applied:

- That it is a aquifer recharge area
- That the soil is erodible
- That the altitude is less than 4,000m.a.s.l
- That several communities are near and capable to supply labor necessary for reforesting

In Figure 4.15.1-2 the location of the selected areas is shown applying these criteria. A and B groups were chosen as area subjected to this project. Groups C was not included due to the population's low density, which will translate as few labor supply for executing the necessary work.

In Table 4.15.2-2 the volume of the reforesting plan and selected vegetation recovery is shown.

Table 4.15.2-2 Reforesting Plan and Selected Vegetation Recovery of the upper basin

Group A

Area No.	Surface to reforest (ha)			Execute at:
	Pine	Queñua	Total	
47	650,04		650,04	Second year
48	311,91		311,91	Second year
49	211,90		211,90	Third year
50	276,40		276,40	Third year
51	79,94		79,94	Third year
52	166,27		166,27	Third year
53	55,96		55,96	Third year
56		0,05	0,05	Third year
61	67,58		67,58	Fourth year
102	548,38		548,38	Fourth year
103	161,45		161,45	Fourth year
Total	2.529,83	0,05	2.529,88	

Group B

Area No.	Surface to reforest (ha)			Execute at:
	Pine	Queñua	Total	
42		63,03	63,03	Second year
43		24,30	24,30	Second year
44		12,22	12,22	Second year

Area No.	Surface to reforest (ha)			Execute at:
	Pine	Queñua	Total	
45	249,00		249,00	Third year
65		397,23	397,23	Second year
66	14,69		14,69	Third year
67	1,06		1,06	Third year
68	26,90		26,90	Third year
69	30,28		30,28	Third year
70	0,00		0,00	Third year
71	236,58		236,58	Third year
72		76,53	76,53	Fourth year
73		128,96	128,96	Fourth year
74	173,82		173,82	Fourth year
75	55,19		55,19	Fourth year
76	66,34		66,34	Fourth year
77	14,82		14,82	Fourth year
78	165,11		165,11	Fourth year
79	89,24		89,24	Fourth year
Total	1.123,03	717,09	1.825,30	

(Source: JICA Study Team)

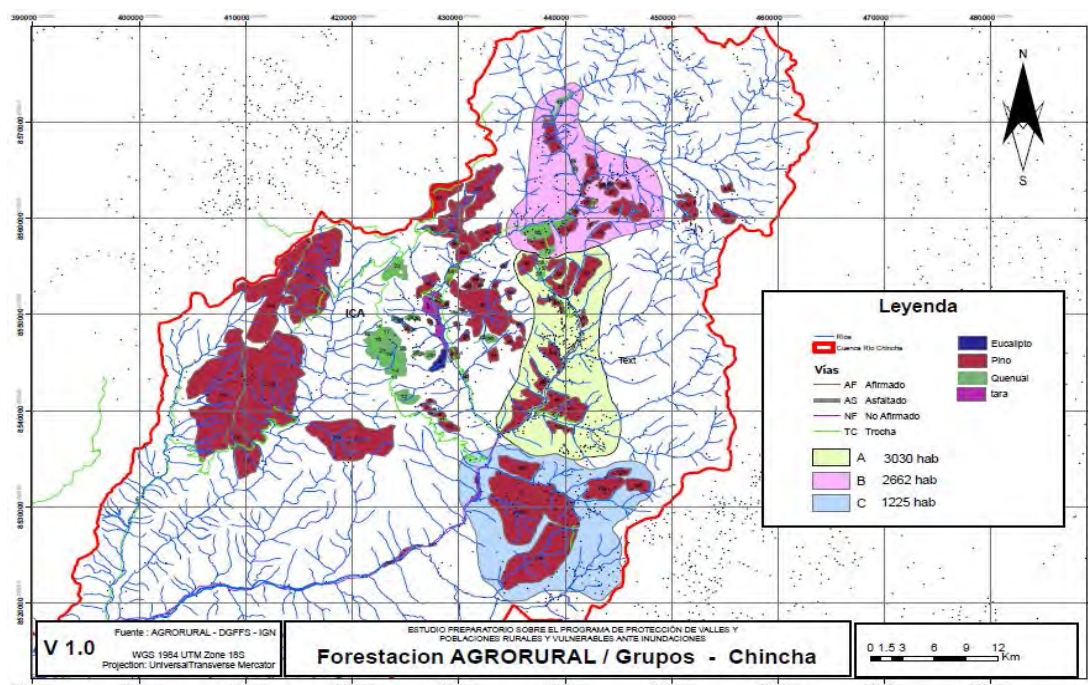

Figure 4.15.2-2 Reforesting plan and selected vegetation recovery of the Chincha river

4) Execution costs

This execution costs were estimated following:

- Seedlings unitary costs (unitary price + transportation)
- Labor cost

Seedlings suppliers can be i) Agrorural or ii) Private Suppliers. For reforestry the upper watershed of Chincha River the seedlings will be obtained from AGRORURAL.

To estimate unitary cost of labor, we are proposing to apply unitary cost of common labor for forestry of margins, meanwhile for the upper watershed of Chincha River we are thinking of hiring local inhabitants disposing half of labor cost in order to beneficiate (additional income) to the local community.

i) Seedlings unit cost

This cost was defined based on the information obtained through AGRORURAL interviews. Because seedlings costs and transportation cost varies depending on suppliers, the average was applied.

ii) Labor cost

This was determined by 40 trees / person per day, according to the gathered info by AGRORURAL and irrigation commissions. In margins reforestry, unit cost of labor would be 33.6 soles /men-day, in the upper basin was determined as 16.8soles/men-day, which is half the first one. In table 4.15.2-3 unit costs applied to estimate direct work costs by ha are shown.

Table 4.15.2-3 Unit cost of reforestation

	Units	Eucalyptus	Pine	Queñua	Tara
Plants per hectare	Plant/ha	2.960	2.960	2.960	2.960
Cost of seedlings	Soles/ha	1.332	1.480	1.332	1.332
Labor Cost	Soles/ha	1.243	1.243	1.243	1.243
Total Cost of reforestation	Soles/ha	2.575	2.723	2.575	2.575

iii) Reforestation execution cost

In Table 4.15.2-4 direct cost of the works for the reforestry works on the upper watershed is shown.

Table 4.15.2-4 Direct cost of reforestation

Area No.	Species to be planted		
	Pine	Queñua	Total
Group A			
2 nd year	2.619.390	0	2.619.390
3 rd year	2.152.450	129	2.152.579
4 th year	2.116.887	0	2.116.887
Subtotal	6.888.727	129	6.888.856
Group B			
2 nd year	0	1.279.209	1.279.209
3 rd year	1.520.823	0	1.520.823
4 th year	1.537.188	529.137	2.066.325
Subtotal	3.058.011	1.808.345	4.866.356
Total	9.946.738	1.808.474	11.755.212

Within the cost of the project, the following will be estimated:

11.7 million soles (direct work cost) x 1.882 (indirect work cost, etc) = 22.1 million soles

5) Project's cost-benefit

For the estimation of benefits for the upper watershed, an example of the cash flow was taken for each hectare of Pine typical productive forest in the Mountain region of Peru, modifying density and plantation cost and adding up carbon benefit. So, a relation C/B by hectare unit of 5.20 was determined as well as the ENPV of US\$ 14,593 (see table 4.15.2-5).

6) Working calendar

This includes for the 1st year: choosing an NGO (by the consultant) to offer support to the community, forestry detailed elaboration (by NGO), organize the community to perform reforestation works (by NGO), seedlings production, etc. Preparation stage

For the next three years (from the 2nd to the 4th) reforestation labors will be carried out. Seedling production require between 3 to 6 months. Aiming to ensure a high survival it is best to use big seedlings, dedicating its production to the dry season (7 months, between April and October) and completing the transplant in the rainy season (four months between November and March).

Years	Dry season						Rainy Season				
	May	June	July	August	Sept.	Oct.	Nov.	Dec.	January	February	March
First	Preparatives										
Second	Seedling production (7 months)						Transplant			Reserve	
Third	Ídem						Ídem			Reserve	
Fourth	Ídem						Ídem			Reserve	

(Source: JICA Study Team)

Figure 4.15.2-3 Reforestation and vegetal recovery calendar

7) Conclusions

According to Table 4.15.2-5, this alternative will have a positive economic impact if benefits of carbons absorption are taken into consideration. But it will have a negative impact if its impact is only to control floods and no damage is reduced nor reforesting 4,000 ha is done. The projects' cost is high, estimated in 22.1 million soles, that represent 46% of the total project's cost of this river, of 48.4 million soles. So, this alternative is concluded not to be included in this Project considering that the model area reforestation must be implemented as a project aside from the present Project.

Table 4.15.2-5 Results from cost-benefit relation of the Pine reforestation project (In US\$/ha)

Year	Investment Cost (A)	Forestry Labors (B)	Administrative expenses (C)	Incomes (D)	Cash flow (without taxes) -(A)-(B)-(C)	Taxes (E)	Cash flow (with taxes) (D)-(E)	Total costs (A)+(B)+(C)	Benefits as carbon sink (F)	Total benefits (D)-(E)+(F)
0	481,56	449,39	321,16	0,00	-1.252,11	0,00	-1.252,11	1.252,11	0,00	0,00
1	226,17	704,13	111,65	0,00	-1.041,95	0,00	-1.041,95	1.041,95	222,79	222,79
2	0,00	704,13	84,49	0,00	-788,62	0,00	-788,62	788,62	445,58	445,58
3	0,00	0,00	0,00	0,00	0,00	0,00	0,00	0,00	668,37	668,37
4	0,00	0,00	0,00	0,00	0,00	0,00	0,00	0,00	891,16	891,16
5	0,00	0,00	0,00	0,00	0,00	0,00	0,00	0,00	1.113,95	1.113,95
6	0,00	1.000,96	120,12	1.614,55	493,47	148,00	345,47	1.121,08	1.336,74	2.803,29
7	0,00	0,00	0,00	0,00	0,00	0,00	0,00	0,00	1.559,53	1.559,53
8	0,00	0,00	0,00	0,00	0,00	0,00	0,00	0,00	1.151,08	1.151,08
9	0,00	0,00	0,00	0,00	0,00	0,00	0,00	0,00	1.522,39	1.522,39
10	0,00	0,00	0,00	0,00	0,00	0,00	0,00	0,00	1.893,71	1.893,71
11	0,00	0,00	0,00	0,00	0,00	0,00	0,00	0,00	2.265,03	2.265,03
12	0,00	0,00	0,00	0,00	0,00	0,00	0,00	0,00	2.636,34	2.636,34
13	0,00	1.491,46	178,97	4.372,73	2.702,30	809,96	1.892,34	1.670,43	3.007,66	6.570,43
14	0,00	0,00	0,00	0,00	0,00	0,00	0,00	0,00	3.378,97	3.378,97
15	0,00	0,00	0,00	0,00	0,00	0,00	0,00	0,00	4.178,43	4.178,43
16	0,00	0,00	0,00	0,00	0,00	0,00	0,00	0,00	6.513,78	6.513,78
17	0,00	0,00	0,00	0,00	0,00	0,00	0,00	0,00	8.849,13	8.849,13
18	0,00	0,00	0,00	0,00	0,00	0,00	0,00	0,00	11.184,48	11.184,48
19	0,00	0,00	0,00	0,00	0,00	0,00	0,00	0,00	13.519,84	13.519,84
20	0,00	0,00	0,00	7.625,00	7.625,00	-2.288,00	5.337,00	0,00	15.855,19	21.192,19

Net cost current value = 3.477,84

Benefit net current value = 18.071,01

Relation C/B = 5,20

ENPV = \$14.593

4.15.3 Sediment Control Plan

For the long-term sediment control plan, it is recommended to execute the necessary works in the upper watershed.

The Sediment Control Plan in the upper watershed will mainly consist in construction of sediment control dikes and margin protection works. In Figure 4.15.3-1 the sediment control works disposition proposed to be executed throughout the watershed is shown. The cost of Chincha River works was estimated focusing on: a) covers the entire watershed, and b) covers only the priority areas, analyzing the disposition of works for each case (refer to Annex-6 Sediment Control Plan, 2.3). The results are shown in Table 4.15.3-1.

Due to the Chincha River extension, the construction cost for every alternative would be too high in case of carrying-out the margin protection works, erosion control dikes, etc. Apart from requiring a considerably long time. This implies that the project will take a long time to show positive results. So, it is decided that it is impractical to execute this alternative within this project and should be timely executed within the framework of a long-term plan, after finishing this project.

Table 4.15.3-1 Upper watershed sediment control works execution estimated costs

Watershed	Approach	Margin Protection		Strip		Sediment control dike		Total works direct cost	Project Cost (Millions S/.)
		Vol. (km)	Direct Cost (Million S/.)	Vol. (units)	Direct Cost (Million S/.)	Vol. (units)	Direct Cost (Million S/.)		
Chincha	All Watershed	381	S/.407	38	S/.1	111	S/.116	S/.524	S/.986
	Prioritized Section	381	S/.407	38	S/.1	66	S/.66	S/.474	S/.892

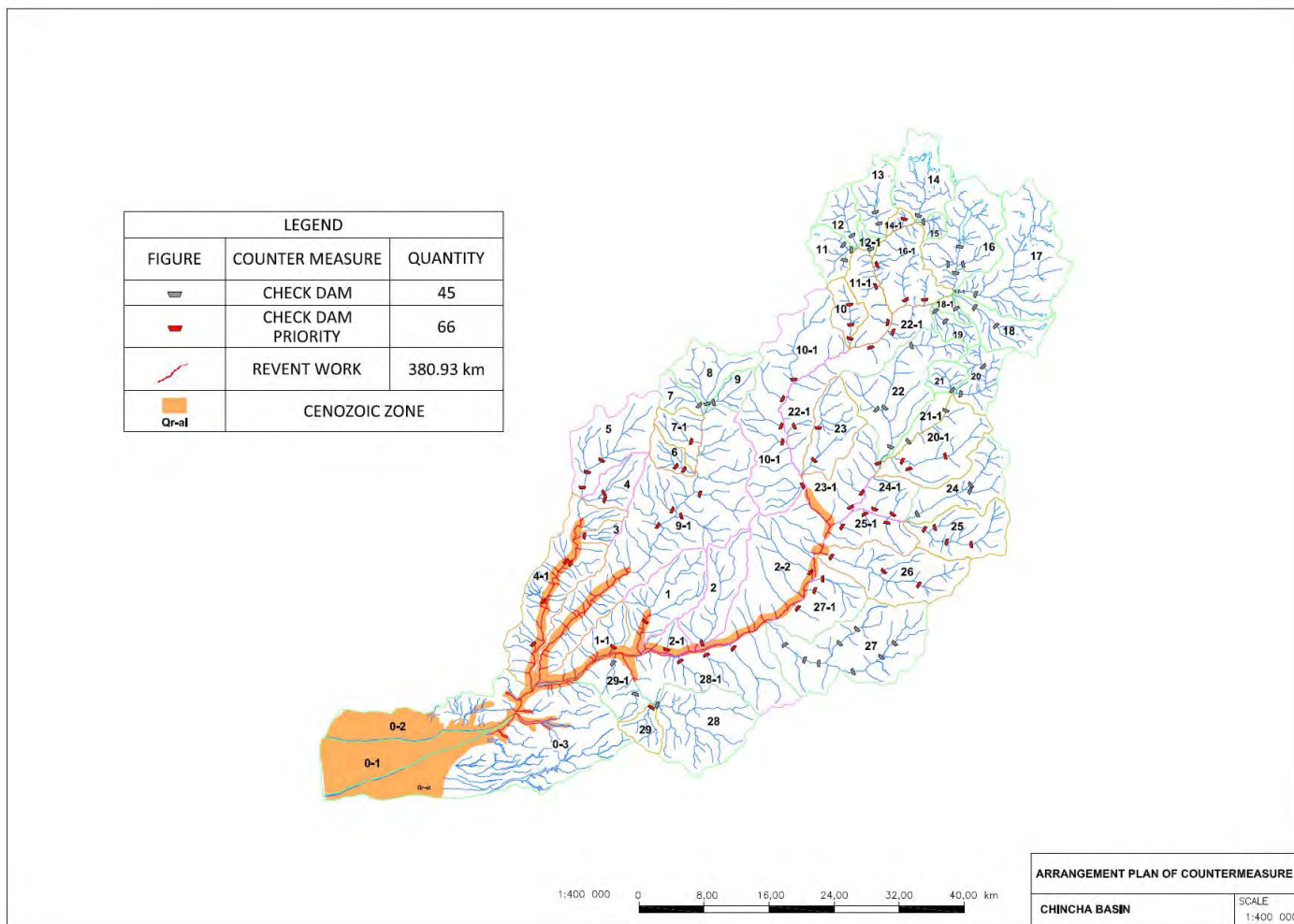

Figure 4.15.3-1 Sediment control works location Chincha river watershed

5. CONCLUSION AND RECOMMENDATION

5.1 Conclusion

The flood prevention facilities selected finally in this Project are safe in structural, and have high viability and give scarcely impact to the environment. It is concluded that the Project should be implemented as soon as possible so that the high vulnerability against flood in valleys (Valles) and rural communities could be reduced and the social economic development will be promoted in the Project area.

5.2 Recommendation

Based on the knowledge and experience obtained from this Study, the following recommendations are presented on the implementation of this Project and the future flood control measures in Peru.

5.2.1 Recommendation on Implementation of This Project

(1) Problems to be solved at present

- 1) The project cost will be covered by the central government (through the DGIH), regional governments and irrigation committees.

The sharing ratio among stakeholders is assumed provisionally 80% for the central government (in this case MINAG), 15% for regional government and 5% for irrigation committee. Since the total cost of this Project was determined in the Feasibility Study, the final ratio will be determined through negotiation among 3 parties as soon as possible.

- 2) The area to be occupied by the flood prevention facilities and the plantation along river was determined in this study. It is recommended that the Project holder (DGIH) should define the limit of river area with private land and continually should carry on the process of land acquisition based on the Land Acquisition Law, which are; Emission of Resolution for land acquisition by the State, Proposition of land cost and compensation for land owner, Agreement of the State and land owner, Payment etc.

- 3) Confirmation of implementation agency of the Project

The implementation agency is assumed to be PSI, MINAG, however DGPI, MEF and OPI, MINAG do not always agree that, so that the final implementation agency will be determined as soon as possible.

- 4) As to the environment impact assessment of this Project, DGAA, MINAG evaluated the Initial Environment Assessment (EAP) of the Project and classified this Project in to Category I so that the additional environment assessment is not required, however it is necessary to proceed the process of preservation of archeological heritage.

- 5) Acquisition of CIRA (Certificación de Inexistente de Restos Arqueológicos)

DGIH has to promote the process to obtain the CIRA in the detail design stage. The process to be

taken is i) Application form, ii) Copies of the location drawings and outline drawings, iii) voucher, iv) Archaeological Assessment Certificate.

- 6) The operation and maintenance after implementation of the Project will be carried out by the irrigation committee. They are not familiar the flood prevention facilities which are different type of structure from the agricultural facilities such as irrigation channel, intake and so on, so that that the technical and economic assistance by MINAG and local government

(2) Structural measures

1) Basic policy of flood control

In the basic policy of flood control, the flood prevention measures should be prepared gradually from the downstream to the upstream of river. However the facilities with high priority such as wide inundation area and giving serious impact on the socio-economy of the region were selected and planned to be implemented in this Project.

Once the preparation in the upstream area is completed, of which influence occurs in the opposite bank or downstream area. And the asset will be accumulated by preparation of flood prevention measures which means the increase of damage potential, if the flood over design flood will occur the damage might be enlarged more than before due to increase of damage potential. Therefore it could not be said that the damage will be not always decreased, which should be noticed to people and the land use regulation should be prepared.

2) Problems for flood control planning in Chincha river

The characteristics of Chincha river is that in case of unequal diversion of flood water to Chico river and Matagente river , the flooding water inflow unevenly to one river causing heavy damage in all section of that river due to insufficient discharge capacity. Even when the water is adequately distributed among rivers Chico and Matagente in a 1:1 relation, Chico River may overflow at 15Km and 4Km causing great damages on the left bank, and Matagente River may overflow at 9Km and 3Km, flooding great areas from right bank.

Therefore, the basic policy of flood prevention is to build the diversion weir and embankment with bank protection in the section where inundation areas in the past due to insufficient discharge capacity. The flood prevention works are planned on the condition that the water diversion is properly implemented.

The most important facility is the diversion weir at the diversion point of Chico river and Matagente river. After completion of the weir the operation and maintenance for adequate diversion of discharge will be required by monitoring of sedimentation at and the upstream of the weir.

The sections with high priority are selected in Chincha river , even when the facility in each section is complete it cannot be said that the preparation of whole Chincha river is completed. In future the sections where discharge capacity is not enough and need the strengthening dike will be continuously prepared for flood control.

3) Problems in design and construction work

i) Construction work period

The dry season in the study area is from May to November when the level of water is very low or the river dries up, however the possible construction period is desirable to be from April to December considering the transition period from season to season.

Each river characteristics / features should be taken into account, that is, that the Chincha river is seasonal rivers. At the same time, the crop season cycle in the areas of direct influence should be taken into account, so that traffic jams caused by the large trucks and farming machinery is prevented.

ii) Safety of dike

Dikes will be made of material available in the zone (river bed or banks). In this case, the material would be sand and gravel or sandy soil with gravel, of high permeability. The stability problems forecasted in this case are as follows.

- Infiltrate destruction caused by piping due to washing away fine material
- Sliding destruction of slope due to infiltrate pressure

In order to secure the stability of dike the appropriate standard section should be determined by infiltration analysis and stability analysis for sliding based on unit weight, strength and permeability of embankment material.

The importance in dike construction is sufficient compaction of dike material. The cost estimate standard in Peru the compaction is to be made by tractor; however for the sufficient compaction it is desirable to use compaction equipment such as vibration roller etc.

And in order to supervise the compaction of material, the density test and grain size analysis are important, of which are specified in the technical specification of the tender document (refer to Annex-9 Construction Planning/Cost Estimate, 3.3 Cost Estimate of Direct Cost, Item 2.2 Survey and Quality Control of Integrated List).

iii) Reduction of bank protection cost

The cost of construction work for the revetment occupies over 80% of the direct cost of the project in the embankment section. Moreover, the conveyance cost for the rocks from quarry site occupies 45% of the revetment works. In the places where existing revetment works and groin works still remain, it should be considered that reusing of materials leads to reduction of construction costs.

iv) Balance of banking and excavation volume

As for balance of earth volume for embankment and excavation, there are shortages earth materials for embankment with in the Chincha river. Since the land along the river is used for farmland, the earth materials for embankment shall be taken from riverbed material. In case of excavation in riverbed for making flow capacity increase, there is a possibility that dike height will be lower a little. On the other hand, there is a possibility for promoting riverbed scouring due to steep slope of river. In the detail design phase, the selection of adequate places for borrow pits

shall be important.

v) As for the diversion weir planning in the place which distributes to the Chincha River and the Matagente River, since the existing weir is not in operation, the mechanism of destruction by floods shall be clarified and detail design shall be done by taking into account the safety for floods. The consolidation dam work in direct upstream of the diversion weir is also destroyed by floods. Destruction in this section is caused by concrete structures, scouring of foundation and impacts by sediment flow. Hydraulic model test might be conducted for the clarification of hydraulic phenomena, if necessary, judging from the detail design results.

Moreover, the upstream consolidation work is close to filling up by sediments. The riverbed fluctuation for the design should be also considered.

(3) Non-structural measures

1) Afforestation

The afforestation and vegetation recovery plan is divided into i) short term plan, ii) middle term plan (in upstream of Chincha river) and iii) long term plan (upstream area in each river), among which the short term plan is adopted in this Project. In future flood control plan it is necessary that the middle term plan and the long term plan will be executed, however the long term plan requires enormous project period and project cost. The project period and cost of the middle term plan are 4years and 22.1 million soles respectively. The middle term plan could be realized although the project size seems to be rather small. In this middle term plan the negotiation between the irrigation committee in Chincha river and framer in the upstream area has been continued for long year. If the budget will be prepared, the project will be realized easily. Therefore it is recommended that at first the middle term plan is realized as an model project, next the long term plan will be realized by the effort of securing budget step by step.

2) Sediment control and riverbed fluctuation

i) Sediment control plan

Cost for sediment control plan in the mountainous area is expensive (986 million soles), in addition project need long term periods. There are no objects to be conserved in the mountainous area, so cost-benefit performance is low. Main purpose in this project is mitigation of the flood disaster. With the view to this purpose, it is judged that sediment control works in the alluvial fans is most effective. It is judged that implementation of the river structures that have the functions of sediment control in Chincha basin that have a profound effect of the sedimentation would be most effective.

Despite being distinct from the project purpose, in Peru sediment disasters have occurred frequently. So Non-structural measures to mitigate the sediment disasters would be suggested as shown below. These Non-structural measures are more economical than structural measures and have function to prevent the human life and minimum property from the sediment disaster.

- Regulation of agricultural areas and residential areas

- Setting the alert rainfall for each region and establishment early warning Systems.
- Collect sample of sediment disaster and raise awareness of disaster prevention through education and patrimony of disaster prevention

ii) Riverbed fluctuation

The results of field investigation and riverbed fluctuation analysis show no urgent necessity of sediment control measures in all rivers. And it is important that the effect of the facilities is confirmed in Chincha river upstream of which the sediment control facilities planned.

From now on the monitoring system for topography of river channel and local scouring should be established in all rivers depending on the riverbed fluctuation characteristics, and the accumulation of such basic data is required.

(4) Disaster prevention education/capacity development

1) Soft counter measures for reduction of flood damage

The design flood discharge in this Study is a flood with return period of 50 years which is calculated based on the past rainfall observation data. However the flood over design flood may occur due to El Niño or extraordinary meteorological phenomena. Since the forecasting of such floods is difficult it is impossible to prepare for such floods by hard counter measures. Since there is still risk for such floods, the establishment of soft countermeasures such as flood defense work, evacuation, preparation of hazard map and the notification and education to people is required.

2) Promotion of community disaster prevention

It is important to promote the community disaster prevention, which reinforces the effect of this Project and induces the local people participation to the Project. The long time approach and activities are required until that the self and mutual assistance is motivated and the people start voluntarily concrete activities as a first step of activation of voluntary disaster prevention organization.

It is necessary that the irrigation committee builds the community disaster prevention system as a core based on the disaster prevention education in this Project in order to increase the effect of the Project

5.2.2 Recommendation for Future Flood Control Plan in Peru

(1) Preparation of comprehensive master plan for flood control

There are almost no flood prevention facilities in the Study area although the dikes are built in some places. The flood prevention facilities constructed in this Project are also partly, however they cover the important points and give the high economic effect as seen in the social evaluation results so that it can be said very significant project.

However, as to the future flood control in Peru, the integral master plan for major basins should be established and implemented step by step for objectives of not only agricultural facilities but also urban areas, roads, bridges etc.

(2) Establishment of implementation agency for integral flood control project

The counterpart ministry of this Project is MINAG which is responsible for the agricultural sector so that they cannot easily implement the disaster prevention project belong to the other sector.

In order to realize the above (1) it is necessary that the role of the existing agency will be change to be able to implement the flood control plan with integral purpose or establishment of new agency. By such agency the integral flood prevention measures and operation and maintenance of river such as dike, bank protection, groin, erosion of river bank, sedimentation in riverbed, intake weir etc. should be carried out completely.

(3) Execution of strict river management

The boundary of river area and private land is not clear, the river area is used sometimes as agricultural land, and the garbage is dumped in the river area illegally, which means the administration of river area is not well performed. Therefore the preparation of river law system and strict application of it is quite required.

(4) Establishment of nationwide network of rainfall and discharge observation stations

The estimation of flood discharge and flood pattern is indispensable as basic data for establishment of flood control plan. In order to estimate the above data with appropriate accuracy, the rainfall observation stations with enough density in the basin and the discharge observation stations at important points along the river are necessary as well as hourly observation data. And in order to estimate the flood discharge and flood pattern, the hourly data is indispensable.

However the data to be used in the Study area is very limited, for example, in the Yauca basin with area of 4,312km² there are 7 rainfall stations, of which only one station (Cora Cora2) is under operation. The observation data is all daily base for rainfall and discharge and is not hourly base

To promote the flood control in Peru, the establishment of network of rainfall and observation stations is indispensable. To do so, it is necessary that the master plan of observation network covering all Peru is to be established and the base stations are selected and the observation is carried out

The followings are to be examined to make the master plan and to select the basic stations.

- * Review of observation data of existing stations
- * Select observation stations to be used and digitalize of available data
- * Plan of observation network and classification of planned and existing stations depending on importance
- * Renewal of observation equipment in the existing stations depending on importance
- * Installation new basic stations
- * Plan of transmission system of data
- * Plan of recording and keeping system of observation data
- * Plan of operation and maintenance system

* Trial observation at the stations above

In implementation of above project, the all Peru is divided into several areas depending on the importance, then the project will be implemented step by step, and the implementation might be done by the assistance of foreign country

The administration of observation data is performed by SENAMHI at present, the observation data will be opened regularly to the public and can be used widely by the utilizer.

