

## **Chapter 5 Policy for the Development Plan of the urban railway from the central of Pune to Hinjawadi IT park**

### **5.1 Policy for the Development Plan**

#### **5.1.1 Conditions to be Considered**

Here, we will set the basic conditions of the railway plan that will be considered in 5.1.2.

##### **1) Basic conditions for designing the alignment of the railway**

###### **(1) Horizontal alignment**

Horizontal alignment will be designed based on the following basic conditions.

- (a) Elevated section: Trains should basically run through public road sites
- (b) At-grade section: Trains should basically run through public road sites
- (c) Radius of the curve: At least 20m, preferably 40m or more

###### **(2) Surface level of the track**

Surface level of the track will be set based on the following basic directions.

- (a) Elevated stations with road traffic running underneath:  
Height will be basically 13.5m or higher measured from the road surface level taking into account the structure gauge (i.e. 5.5m or higher), girder height, clearance between floor level and ceiling at concourse, and structurally appropriate height of track structure.
- (b) Elevated part:  
Height will be basically 8.5m or higher measured from the road surface level taking into account the structure gauge (i.e. 5.5m or higher), girder height, and structurally appropriate height of track structure.
- (c) At-grade part:  
It will be basically road surface level. However, necessary modifications will be made to avoid steep slopes at at-grade stations.

###### **(3) Vertical alignment**

Vertical alignment will be designed based on the following basic directions.

- (a) Vertical gradient: 70‰ or lower, preferably 50‰ or lower
- (b) Vertical alignment at elevated areas between stations

While we have set in (2) (b) above the height of elevated parts to be 8.5m or greater above the road surface level, it will be kept at a higher level if it is considered preferable to do so in between stations.

## **2) Basic directions for selecting railway structure (elevated, at-grade and under-ground areas)**

Railway structure (elevated, at-grade and under-ground area) will be selected based on the following basic directions.

- Adopt a structure that can reduce construction cost to the extent possible
- Avoid purchasing land to the extent possible by constructing basically on public land and thereby avoid the delay, cancellation, and revision of the plan of the project
- In order to minimize the impact on road traffic, basically avoid at grade intersections with major roads and secure two lanes each way

## **3) Exclusive use of the railway, and conditions for using it in combination with road traffic**

The following direction will be applied with regards to whether to use the railway exclusively or in combination with road traffic.

- In order to ensure safety and manage the operation soundly, the railway will be used exclusively, setting up fences in at-grade sections

## **4) Railway operation in at-grade sections**

Railway operation in at-grade sections will be carried out based on the following directions.

- Taking into account passenger accessibility, the level of impact stations have on road traffic, and the operational plan of BRT as well as some other factors, railway operation will basically take place at each side of the roads with traveling directions consistent with the road traffic
- Railway operation should not interfere with road traffic running in a straight line

### **5.1.2 Railway Plan**

#### **1) Present and future road planning**

In this study, we have surveyed the area where the planned LRT railway lines are to be developed, namely, a 15km area stretching from around Sancheti Hospital of Pune City to Shivaji Chowk which is the entrance to Hinjawadi IT Park. Nevertheless, since the objective of the technical survey was to understand the basic alignment and railway structures and to estimate the general project cost, it was not an in-depth survey. The survey area on both sides of the road was generally up to the public and private border and was a cross-section and horizontal survey every 100m. Please refer to the survey drawing shown in 5.1.2 7). Furthermore, since then the railway plan only covered an approximately 15km area up to the entrance to Hinjawadi IT Park, measurement within the IT Park

had not been carried out and consideration would be made based on existing documents and satellite images available on the Internet.

The road situation within the PMC is: narrow and complex in the area from the starting point (i.e. JM Temple) to Pune University with a major trunk road with heavy traffic and three flyovers; and a simple layout for a while without any major intersections until after past Pune University. Road work is taking place within PCMC, with some sections already completed, to widen the road to 45m so that a BRT can run. A four-lane road (two lanes each way) with a relatively undulating surface runs within Hinjawadi IT Park. The situation of the existing roads on the planned LRT route and their road widening plans are shown in Table 5.1.1.

**Table 5.1.1 Existing Roads on the Planned LRT Route and Road Widening Plans**

Sr. No.	Section (survey km post)	Administrative Category under Jurisdiction	Current Composition of Road Width		Planned Composition of Road Width	
			Traveling Direction of Traffic	Composition of Road Width	Traveling Direction of Traffic	Composition of Road Width
1	0+000 – 0+600	PMC	One-way	Four lanes		
2	200.000 – 520.000		One-way	Two right turn lanes; Two straight lanes; Two left turn lanes		
3	520.000 – 840.000		Two-way	Three lanes one way		
4	840.000 – 1250.000		Two-way	Two lanes one way at-grade; Two lanes one way flyover		
5	1250.000 – 2230.000		Two-way	Three lanes one way		
6	2230.000 – 2580.000		Two-way at-grade; one-way flyover	Two lanes one way at-grade; Two lanes on flyover		
7	2580.000 – 2920.000		Two-way at-grade; one-way flyover	Two lanes one way at-grade; Two lanes flyover (one lane at-grade around 2600.000)		
8	2920.000 – 3100.000		Two-way at-grade; one-way flyover	Two lanes one way at-grade; Four lanes flyover		
9	3100.000 – 3370.000		Two-way at-grade; one-way flyover	Two lanes one way at-grade; Two lanes flyover		
10	3370.000 – 5600.000		Two-way	Two lanes one way + Two side ways one way		
11	5600.000 – 5850.000		Two-way	Two lanes one way		
12	5850.000 – 6450.000		Two-way	Two lanes one way		
13	6450.000 – 6650.000		Two-way	Two lanes one way (river bridge)		
14	6650.000 – 9700.000	PCMC	Two-way	Road widening taking place to a 45m road	Two-way	BRT at center of the road; 45m-long, three lane one way road
15	9700.000 – 10250.000		Two-way	One lane one way		
16	10250.000 – 11050.000		Two-way	Two lanes one way		
17	11050.000 – 12900.000		Two-way	Road widening taking place to a 45m road	Two-way	BRT at center of the road; 45m-long, three lane one way road
18	12900.000 – 13570.000	Two-way	One lane one way (flyover)			
19	13570.000 – 14220.000	MIDC	Two-way	Two lanes one way	Two-way	Road widening plan exists
20	14220.000 – 14900.000		Two-way	Three lanes one way		
21	14900.000 – 15300.000		Two-way	Two lanes one way	Two-way	Road widening plan exists
22	15300.000 -		Two-way	Two lanes one way		

Source: JICA Study Team

## 2) Selecting railway structure (elevated, at-grade and under-ground areas)

The railway structure will be selected based on the basic directions stipulated in 5.1.1 and in consideration of the situation of the roads in each section shown in (1) above. Rocks are found approximately 5-6m below ground (please refer to 5.2.1) on the subject land for the LRT project. Considering the conformational structure including that of roads, an elevated structure will be adopted as opposed to an underground structure which heightens the construction cost considerably. Results of the study on railway structure in each section are shown in Table 5.1.2.

**Table 5.1.2 Railway Structure of Each LRT Section**

Sr. No.	Section (survey km post)	Administrative Category under Jurisdiction	Railway Structure of LRT	Reason for Selection
1			Elevated	Since there is a major intersection. Also, it will interfere with road traffic running in a straight line when built at-grade
2	200.000 – 520.000		Elevated	Since there exists a major intersection of 520.000. Also, two lanes cannot be secured when made at-grade.
3	520.000 – 840.000		Elevated	Since the sections before and after have to be an overpass, by alignment, it is impossible to make it at-grade.
4	840.000 – 1250.000		Elevated	Since there exists a major intersection of 1080.000. Also, two lanes cannot be secured when made at-grade.
5	1250.000 – 2230.000		Elevated	Since the sections before and after have to be an overpass, by alignment, there is no merit in making it at-grade.
6	2230.000 – 2580.000		Elevated	Since there exists a major intersection of 2450.000. Also, two lanes cannot be secured when made at-grade.
7	2580.000 – 2920.000		Elevated	Since there exists a major intersection of 2900.000. Also, two lanes cannot be secured when made at-grade.
8	2920.000 – 3100.000		Elevated	Two lanes cannot be secured when made at-grade.
9	3100.000 – 3370.000		Elevated	Since there exists a major intersection of 3150.000. Also, two lanes cannot be secured when made at-grade.
10	3370.000 – 5600.000		At-grade	Since two lanes can be secured each way after clearing vegetation along the street when made at-grade.
11	5600.000 – 5850.000		Elevated	Since there exist major intersections of 5780.000 and 5820.000. Also, two lanes cannot be secured when made at-grade.
12	5850.000 – 6450.000		Elevated	Since two lanes cannot be secured and access to the road side will be cut if made at-grade.
13	6450.000 – 6650.000		Elevated	It is necessary to build a bridge exclusively for LRT.
14	6650.000 – 9700.000	PCMC	Elevated; At-grade	Since there exist major intersections of 7080.000, 7190000, and 7450.000, it will be an overpass up to, and at-grade after, 7700.000.
15	9700.000 – 10250.000		Elevated	Current road is one way each way and yet difficult to be widened since they are located in a Defense Area.
16	10250.000 – 11050.000		Elevated	Since it is a road of two lanes each way located in an area lined with stores.
17	11050.000 – 12900.000		At-grade	Since it is a 45m road with BRT and at-grade operation is possible.
18	12900.000 – 13570.000		Elevated	Since it intersects with NH-4. at-grade operation is impossible.
19	13570.000 – 14220.000	MIDC	Elevated	It is a highly congested section with a main road leading to the IT Park. At-grade operation is inappropriate.
20	14220.000 – 14900.000		Elevated	It is a highly congested section with a main road leading to the IT Park. At-grade operation is inappropriate.
21	14900.000 – 15300.000		Elevated	It is a highly congested section with a main road leading to the IT Park. At-grade operation is inappropriate.
22	15300.000 -		Elevated or At-grade	It is a two-lane-one-way road located within the IT Park so Elevated is preferable to secure the existing road. Yet at-grade operation will also be considered as an alternative.

Source: JICA Study Team

### 3) Selecting station locations

In determining the location of stations, the following points will be taken into account, in particular from the viewpoint of passenger demand and convenience.

- Connection with planned metro stations
- Connection with bus terminals
- Connection with planned BRT bus stations
- Location of existing bus stations as a reference
- Connection with major organizations, residential areas, shopping centers and others

In consideration of the points above, preferable locations of the stations were identified as shown in Table 5.1.3.

**Table 5.1.3 Location of Stations**

ID	Name of Stations (tentative)	km posts	Area	Structure of Stations	Function of Stations
St. 1	JM Temple	0KM250M	PMC	Elevated	Connection with Metro lines 1 and 2
St. 2	Sivaji Nagar	0KM590M		Elevated	Connection with bus terminals/national railway stations
St. 3	Police Ground	1KM000M		Elevated	Connection with surrounding housing and schools
St. 4	Pune Central	1KM800M		Elevated	Connection with shopping centers
St. 5	E-Square	2KM300M		Elevated	Connection with shopping centers
St. 6	Pune University	3KM720M		At-grade	Connection with Pune University
St. 7	Armament Colony	4KM250M		At-grade	Connection with residential areas
St. 8	PWD Office	5KM000M		At-grade	Connection with PWD Office
St. 9	Aundh District Office	5KM550M		Elevated	Connection with Aundh District Office
St. 10	Octroi Naka	6KM350M		Elevated	Connection with surrounding housing and stores
St. 11	State Hospital	7KM650M	PCMC	Elevated	Connection with hospitals and BRT
St. 12	Pimple Nilakh	8KM655M		At-grade	Connection with Pimple Nilakh House and BRT
St. 13	Wakad Road Mall	10KM600M		Elevated	Connection with surrounding housing and stores
St. 14	Wakad Chowk 1	11KM490M		At-grade	Connection with surrounding housing, stores, and BRT
St. 15	Wakad Chowk 2	12KM800M		Elevated	Connection with surrounding housing, stores, and BRT
St. 16	Hinjawadi Road Shopping Mall	14KM700M	MIDC	Elevated	Connection with local shopping areas
St. 17	Shivaji Chowk	15KM450M		Elevated	Connection with the area near IT Park entrance
St. 18	TATA Jhonson	16KM900M		Elevated	Connection with rail yard redevelopment area
St.19	Wipro Circle	17KM600M		Elevated	Connection with IT companies
St. 20	Infosys Circle Phase 2	18KM700M		Elevated	Connection with IT companies
St. 21	Mahindra Tech Phase 3	21KM600M		Elevated or at-grade	Connection with IT companies

Source: JICA Study Team

Connection with BRT is shown in Figure 5.1.1. Railway structure selected through the study above and location of the stations are shown in Figure 5.1.2. For the section from St.20 to St.21, two options, namely, elevated and at-grade, will be proposed.

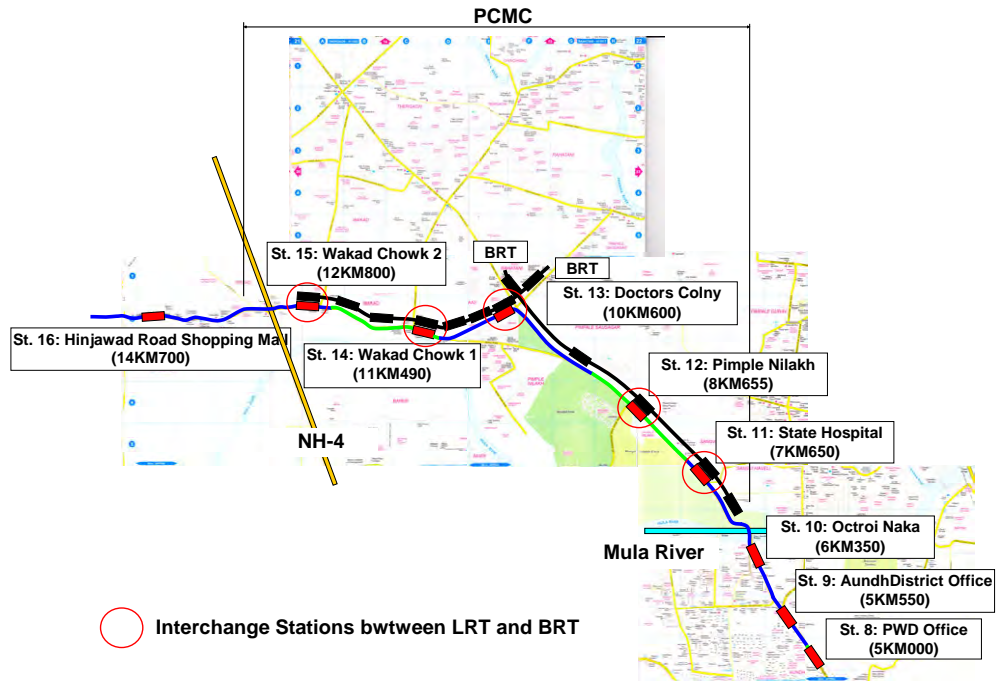

Figure 5.1.1 Connection with BRT

Source: JICA Study Team

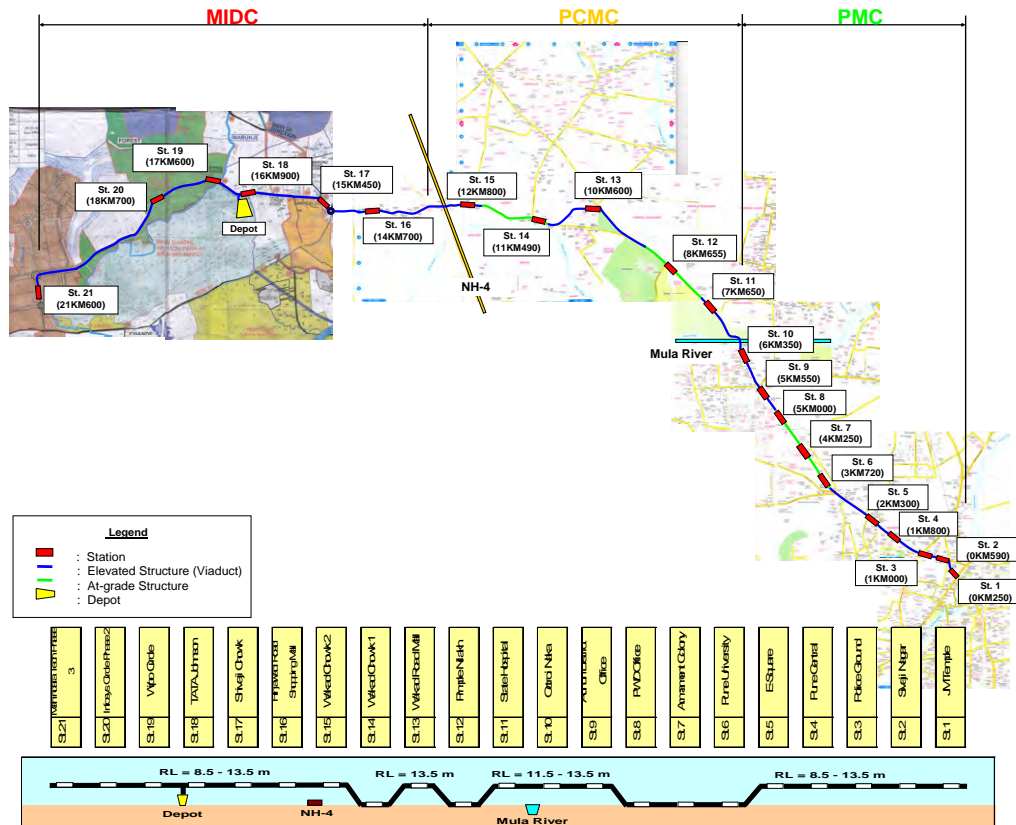

Figure 5.1.2 Railway Structure and Locations of Stations

Source: JICA Study Team

#### 4) Selecting spatial alignment

Taking into account the situation along the road, traffic volume, and others, patterns as shown in Table 5.1.4 are considered for the spatial alignment of the at-grade LRT.

**Table 5.1.4 Spatial Alignment for At-grade LRT Operation**

Spatial Alignment of the Railway	Alignment at Road Center	Alignment at Both Sides of Road	Alignment at One Side of Road
<p>Characteristics</p>	<p>In this case, the railway is aligned at the center of the road. It can minimize the impact on ordinary buses running parallel to the LRT and also prevent pedestrians from entering the railway because it is far from the walkway. On the other hand, stations ought to be set at the center and passengers need to cross the road to reach the station. At intersections, there will be congestion with right-turning automobiles.</p>	<p>In this case, the railway is aligned at both sides of the road. One merit of this pattern is that users do not need to cross the roads, allowing them to more easily access facilities along the track. On the other hand, it also allows pedestrians to easily walk into the railway, renders LRTs running in different directions to be far apart, and requires reconsideration of the location of ordinary bus stations.</p>	<p>In this case, the railway is located at the one side of the roadway. It can minimize congestion with automobiles but requires reallocation of road space.</p>

Source: JICA Study Team

Not restricted to the results of the study in 5.1.2 2), where the following sections were selected to be at-grade: one section within PMC; two sections within PCMC; and the section from St.20 to St.21 within Hinjawadi IT Park, the best spatial alignment will be identified for each section taking into account the characteristics of each LRT alignment as shown in the table above.

##### (1) Spatial Alignment within PMC

The proposed at-grade sections within the PMC are the area from Pune University with km posts of 36000.000-5100.000 to that before reaching the intersection of Aundh District Office. This section is a two-lane one way road with a road width of approximately 34m. By clearing some parts of the boulevard trees covering the roadway, the spatial area for the LRT as well as the present two-lane one way road can be secured. The railway is considered preferable to be aligned at both sides/ways of the road taking into account: accessibility from facilities along the railway; alignment of the road at the station under the ‘Alignment at Road Center’ option; relocation of street lamps in the dividing strip; and others. The railway spatial alignment in this section is shown in Figure 5.1.3 and 5.1.4.

##### (2) Spatial Alignment within PCMC

The two at-grade sections are 45m-width roads with a BRT operational plan, namely, section of km posts of 8100.000-9300.000 and that of 11400.000-12300.000. Spatial alignment of the 45m road is shown in Figure 5.1.7. PCMC has agreed on using one lane per direction, two lanes in total, as the spatial alignment of the LRT. Nevertheless, it is considered preferable that spatial alignment of the LRT be at the center of the road as BRT, which is also planned to be centrally-aligned, taking into



account that the LRT is going to be developed after BRT. By doing so, it can avoid significant modifications to the road and BRT lane and can avoid curved alignment at the station. Figures of the spatial alignment of a 45m road are shown in Figure 5.1.5 and 5.1.6.

**(3) Spatial Alignment within Hinjawadi IT Park**

At-grade operation is also considered as an alternative for the section from St.20 to St.21 within Hinjawadi IT Park. Alignment at one side of the road is considered preferable in this case for this section taking into account the situation where there is a roundabout but no major intersection and returning of the LRT at the final stop.

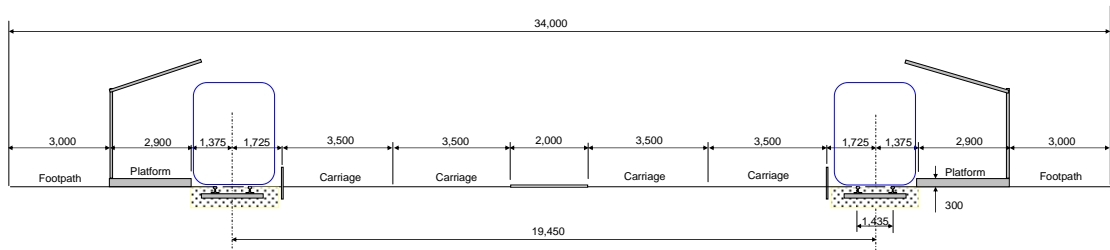

**Figure 5.1.3 Spatial Alignment of the LRT at Station within PMC (area of at-grade operation)**

Source: JICA Study Team

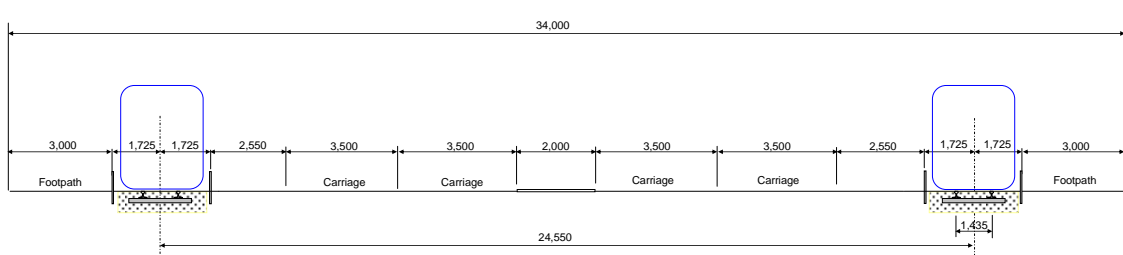

**Figure 5.1.4 Spatial Alignment of the LRT in between Stations within PMC (area of at-grade operation)**

Source: JICA Study Team

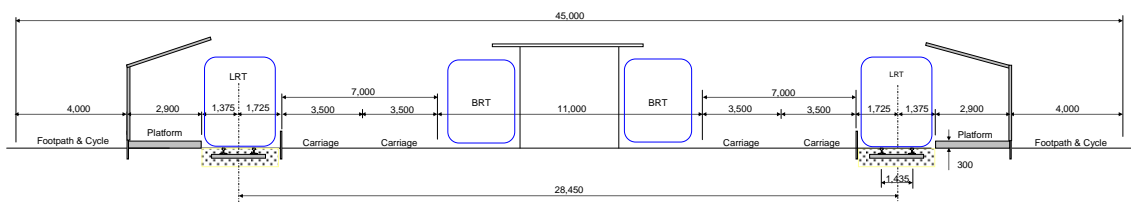

**Figure 5.1.5 Spatial Alignment of the LRT at Station within PCMC (area of at-grade operation)**

Source: JICA Study Team

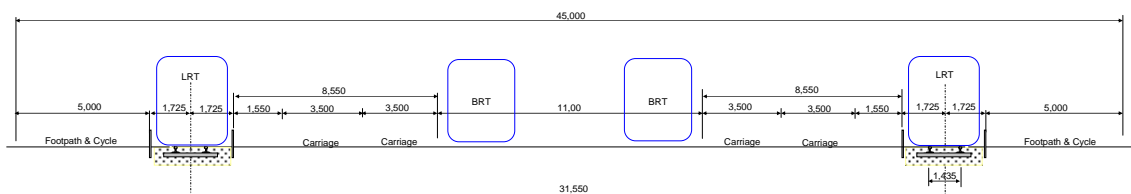

**Figure 5.1.6 Spatial Alignment of the LRT in between Stations within PCMC (area of at-grade operation)**

Source: JICA Study Team

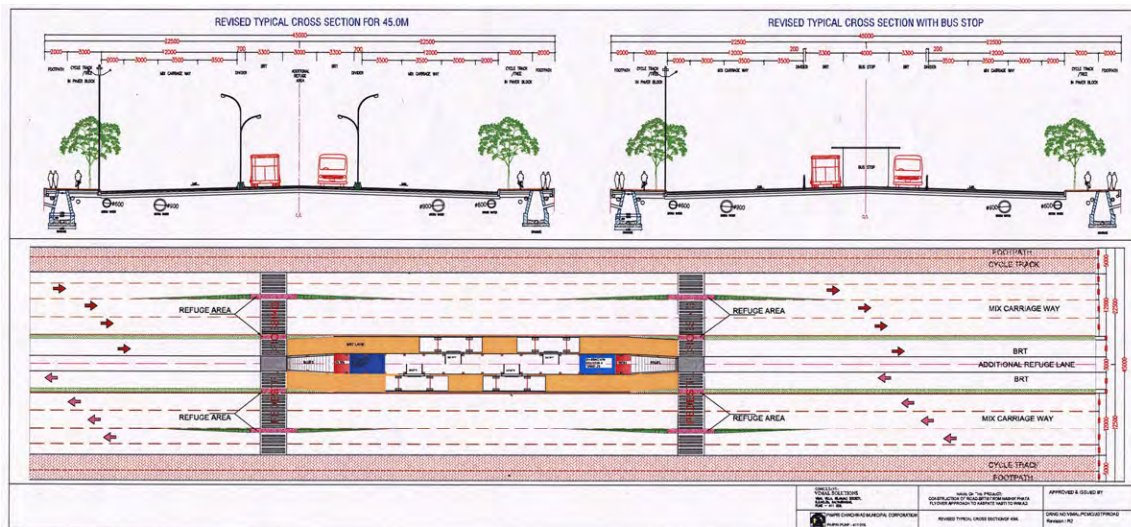

Figure 5.1.7 BRT Plan within PCMC

Source: PCMC

5) Selecting platform styles at stations

Station platform styles fall mainly into two different types: relative style; and island style. The characteristics of the two types are shown in Table 5.1.5 below.

Table 5.1.5 Platform Styles at the Stations

	Separate Style	Island Style
Passengers' Guiding	<ul style="list-style-type: none"> <li>Since the location of stations differ depending on their destinations, unfamiliar passengers can easily make mistakes</li> <li>Passenger congestion is unlikely to be generated</li> </ul>	<ul style="list-style-type: none"> <li>Mistakes are less likely to take place</li> <li>Passenger congestion is likely to be generated when both sides of the trains arrive at the same time</li> </ul>
Alignment	<ul style="list-style-type: none"> <li>Straight line with good view</li> <li>It is easy to extend stations</li> </ul>	<ul style="list-style-type: none"> <li>Since there will be a curve shape, speed will be reduced and level of comfort will decline</li> <li>Track alignment needs to be altered when extending the station,</li> </ul>
Spatial Efficiency (ordinary area)	<ul style="list-style-type: none"> <li>Compared to 'Island Style', space required for installation is great</li> </ul>	<ul style="list-style-type: none"> <li>Compared to 'Relative Style', space required for installation is little</li> </ul>
Spatial Efficiency (intersection)	<ul style="list-style-type: none"> <li>Can set at the spot of outgoing traffic if a right turn lane is set at the side of the intersection where traffic flows in the intersection.</li> </ul>	<ul style="list-style-type: none"> <li>When setting at an intersection, conditions will be more disadvantageous than the Facing Style</li> </ul>

Source: JICA Study Team

Station platform type for the at-grade LRT operation is closely linked to the spatial alignment of the railway. In 5.1.2 4), spatial alignment for at-grade railway operation was designed to be on both sides of the road. Hence, the platform style will automatically be a relative style. For elevated sections, a uni-polar structure is considered appropriate in view of road spatial conditions and hence

it is difficult structurally to adopt an island style. Instead, the relative style is appropriate, which also allows a linear railway alignment.

**Table 5.1.6 Platform Types at Stations**

ID	Name of Stations (tentative)	km posts	Area	Structure of Stations	Platform Type
St. 1	JM Temple	0KM250M	PMC	Elevated	Relative
St. 2	Sivaji Nagar	0KM590M		Elevated	Relative
St. 3	Police Ground	1KM000M		Elevated	Relative
St. 4	Pune Central	1KM800M		Elevated	Relative
St. 5	E-Square	2KM300M		Elevated	Relative
St. 6	Pune University	3KM720M		At-grade	Relative
St. 7	Armament Colony	4KM250M		At-grade	Relative
St. 8	PWD Office	5KM000M		At-grade	Relative
St. 9	Aundh District Office	5KM550M		Elevated	Relative
St. 10	Octroi Naka	6KM350M		Elevated	Relative
St. 11	State Hospital	7KM650M	PCMC	Elevated	Relative
St. 12	Pimple Nilakh	8KM655M		At-grade	Relative
St. 13	Wakad Road Mall	10KM600M		Elevated	Relative
St. 14	Wakad Chowk 1	11KM490M		At-grade	Relative
St. 15	Wakad Chowk 2	12KM800M	Elevated	Relative	
St. 16	Hinjawadi Road Shopping Mall	14KM700M	MIDC	Elevated	Relative
St. 17	Shivaji Chowk	15KM450M		Elevated	Relative
St. 18	TATA Jonson	16KM900M		Elevated	Relative
St.19	Wipro Circle	17KM600M		Elevated	Relative
St. 20	Infosys Circle Phase 2	18KM700M		Elevated	Relative
St. 21	Mahindra Tech Phase 3	21KM600M	Elevated /At-grade	Relative	

Source: JICA Study Team

#### 6) Considering exclusive and/or combined use of the railway

Areas considered to be at-grade have a large traffic volume and the speed of the traffic is relatively high. For this reason, it is preferable to ensure stable LRT operation by preventing accidental contacts of LRT and road traffic as well as pedestrians entering into the railway. With the exception of certain parts such as crossing areas, the railway would be of exclusive use for the LRT, separating the area by fences and/or others to stop people from entering into the railway.

#### 7) Selecting alignment

Concrete alignment will be designed based on the above mentioned considerations. The design criteria for determining the alignment is shown in Table 5.1.7.

**Table 5.1.7 Design Criteria for Alignment**

Item	Design Criteria
Space (distance between the center of railways)	3,050mm (straight line section)
Radius of Plane Curve Main line Station	20m or above (preferably 40m or above) 300m or above
Steepness Main line Station	70‰ or lower (preferably 50‰ or lower) 0‰ (if unavoidable, 5‰ or lower)
Radius of Vertical Curve	1,500m or above
Length of platform	62m (at-grade station), 65m (elevated station)

Source: JICA Study Team

Please refer to Figures 5.4.1 and 5.4.2 for the size of the structure.

➤ **Plane alignment**

The minimum radius of the curve in this LRT line is 50m for the intersections located between St. 1 and St. 2. In addition, there is an 80m radius curve situated between St. 1 and St. 2 and a 60m radius curve across Mula River in PCMC. Others are over 200m. The plane spatially difficult section is that where a flyover runs in parallel from E Square near 2K200M to Pune University near 3K400M. In general, the road width is narrow. The road in front of E Square is particularly narrow which hence shall be avoided and instead a flyover be developed. Please refer to the reference material at the end of the report for the ground plan and to Figures 5.1.8-5.1.12 for elements of the plane alignment.

➤ **Vertical alignment**

Maximum grade in this LRT line is 68‰ in front of Pune University where one line of the elevated bridge crosses over the road and drops to the ground level. The standard is set to be 70‰ or lower but a preferable slope is 50‰ or lower in order to ensure stable operation. Hence, it is considered suitable to slightly move the planned location of Pune University Station to reduce the grade and make sure that it is approximately 50‰. For other steep slopes, the area close to Wipro Circle in Hinjawadi IT Park exceeds 50‰ but this is considered inevitable given its unique geography. Please refer to Figures 5.1.8-5.1.12 for vertical alignment.

**8) Comparison between partial at-grade and whole elevated for LRT**

This study shows partial at-grade plan in order to take into consideration of the characteristics of LRT systems. On the other hand the whole elevated plan which separates LRT and road traffic is shown in APPENDIX-28.

**9) Toward to further study**

In considering alternative plans in the individual locations, it is needed to consider the scale of the land acquisition, the number of resettlement and the negative impact of the environment.





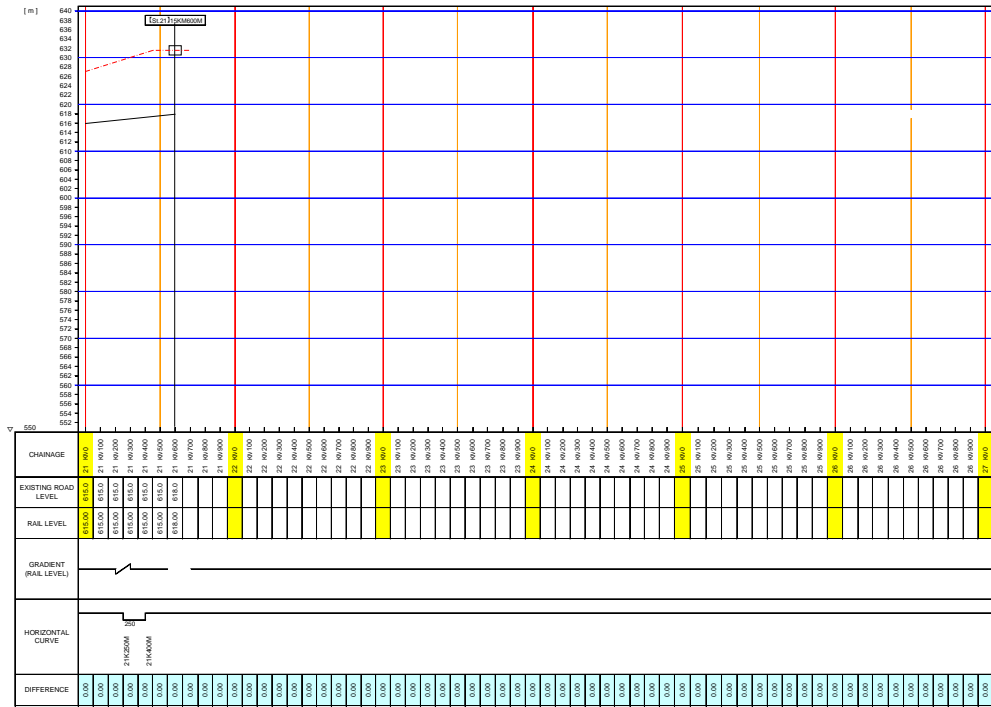

Figure 5.12 Vertical/Horizontal Alignment (5/5)

Source: JICA Study Team

## 5.2 Baseline Information of the Targeted LRT Line (Geological Conditions · Underground Installations · Other Obstructive Structures)

### 5.2.1 Geological Conditions

In this project, five boring surveys were implemented along the targeted LRT line. These were aimed to obtain the reference information for the basic design of the LRT structure and for the construction plan to grasp the trend of the geological soil information. Location and the length between the boring sites were designed considering the grade separation for the existing roads and bridge parts mainly. The locations of the boring survey sites are shown in Table 5.2.1 and Figure 5.2.1.

**Table 5.2.1 Locations of the Boring Sites**

Sr. No.	BH No.	Site	Km post	Coordinates	
				N	E
1	BH-1	Riverside area of Mutha River	-	2049029	0379809
2	BH-2	In front of Pune University	3250.000	2050622	0376342
3	BH-3	Riverside area of Mula River	6500.000	2053396	0374621
4	BH-4	Along the NH-4 Flyover	13200.000	2056129	0368999
5	BH-5	Along the T-junction in Hinjawadi area of Phase 1	16100.000	2056397	0366209

Source: JICA Study Team

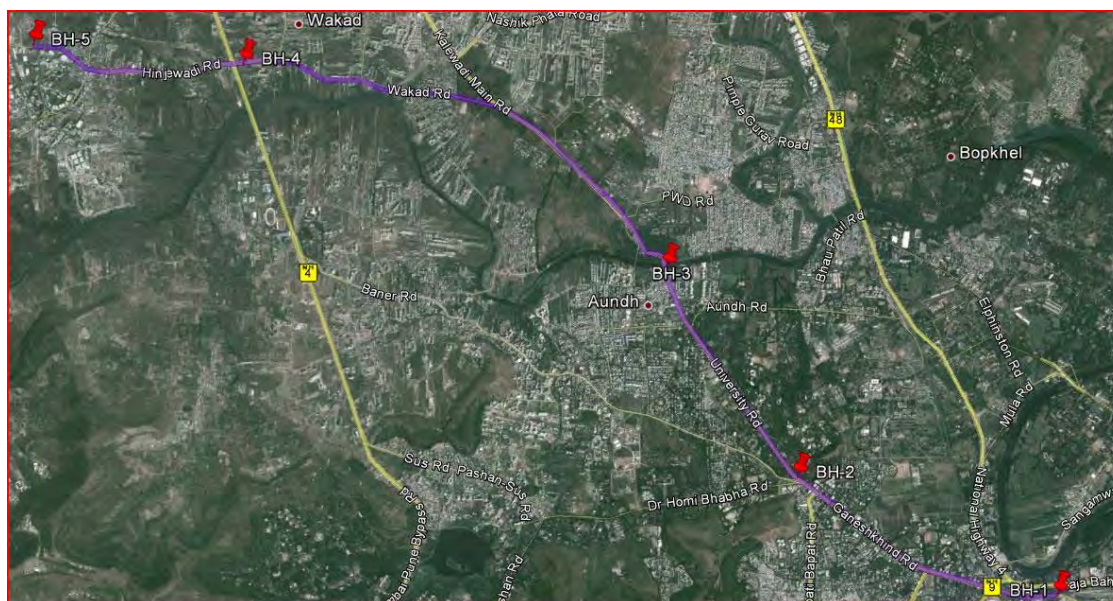

**Figure 5.2.1 Locations of the Boring Sites**

Source: JICA Study Team

From the result of these boring surveys, it is confirmed that there are rocks between 1.1m and 5.5m from the GL under the targeted LRT line. At the sites of BH-1, BH-3, and BH-5, rocks are observed between 1.1m and 2.1m from the surface of the boring survey site. This is because the boring surveys were implemented at the riverside and in a low-lying depression, hence the depth from the GL of the road will be 5 to 6m. Table 5.2.2 shows the relationship between the results of the boring surveys and



the depths from the GL of the boring sites to the rock layers. The boring log and result of the laboratory tests are shown in the Appendix.

**Table 5.2.2 Geological condition of upper part and depth of rock layers**

St. No.	BH No.	Geological condition of upper part (Geological condition from the surface to the rock layers)	Depth of rock layers
1	BH-1	Deposited materials such as rubble and compacted sandy soils	2.1m
2	BH-2	Cohesive soil with sand and cobble stone size basalt	5.5m
3	BH-3	Sand and gravel	1.2m
4	BH-4	Compacted silt and very compacted sand	4.0m
5	BH-5	Sandy silt	1.1m

Source: JICA Study Team

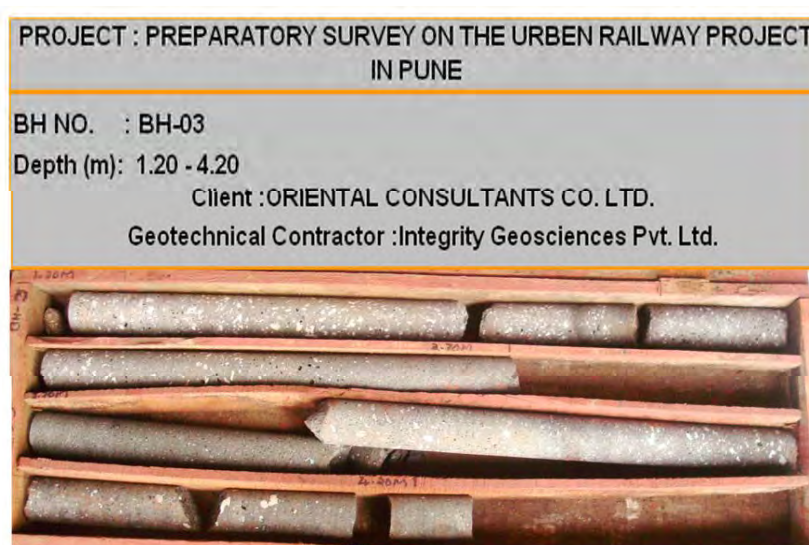

**Figure 5.2.2 Sample of boring survey (BH-3)**

Source: JICA Study Team

## 5.2.2 Underground Installations

It is required to check the detailed information of the types and locations of underground installations. In the area of this targeted LRT line, it is reported that there are underground installations under the dividing strip and sidewalk part but not under the road.

## 5.2.3 Obstructive Structures and Trees

Table 5.2.3 shows the obstructive structures and trees in this LRT project.

**Table 5.2.3 Obstructive Structures and Trees**

No.	Infrastructure	Site
1	High-voltage electrical power lines / Towers	Junction crossing the two BRT lines in PCMC (near St.13)
2		Road with 45 m width in PCMC (near St.14)
3		In the Hinjawadi IT Park (near St.18)
4	Trees	Near St.1, St.3, and St.5
5		Between St.6 and St.7, some parts of the section between St.7 and St.9

Source: JICA Study Team

The summary of obstructive structures is shown below.

- 1) High-voltage electrical power line (near St.13)  
There is high-voltage electrical power line running north-south and the height is 8 to 10 m. The bridge of the LRT flyover will be obstructed near this line.
- 2) High-voltage electrical power line (near St.14)  
There is a high-voltage electrical power line crossing the 45m wide road. This part is designed to be elevated and the LRT line will be obstructed by this power line.
- 3) High-voltage electrical power line (near St.18)  
There is a high-voltage electrical power line along the road. This will obstruct the elevated station and elevated bridges because the height of the power line is relatively low.
- 4) Boulevard trees (near St.1, St.3, St.5)  
There are boulevard trees near the LRT stations and they will obstruct the plan.
- 5) Boulevard trees (between St.6 and St.7 and between St.7 and St.9)  
Boulevard trees in front of Pune University will be obstructive because these trees are located near the center of the road. In some parts of the section between St.7 and St.9, boulevard trees can also obstruct the LRT station and some other parts.

These High-voltage electrical power lines will be raised to the height that these lines do not obstruct this LRT project. The specific plan for relocation and elevation will be discussed with the Power Distribution Company in charge. The Cost will be covered by this project.

#### 5.2.4 Earthquake Circumstances

Pune area is located in the Zone III of earthquake intensity level. This is the middle level and lower than the Zone IV of Delhi and higher than the Zone II of Hyderabad and Bangalore. It is required to consider the appropriate earthquake intensity level to implement the basic design and detailed design.

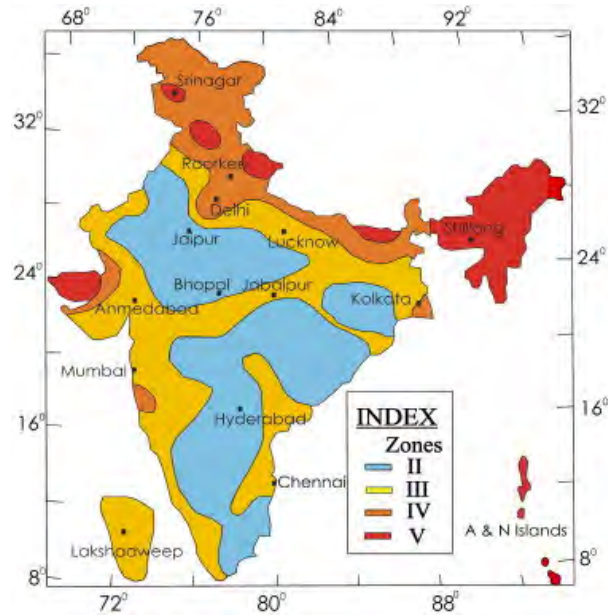

**Figure 5.2.3 Earthquake Intensity Level Map for India**

Source: Internet

## 5.3 Demand Forecast and Operation plans

### 5.3.1 Demand Forecast

See Chapter 3.

### 5.3.2 Train Operation Plan

#### Route of the Line

Route of the line is indicated in Figure 5.3.1.

The route connects the centre of Pune City to Hinjawadi IT Park along the existing road and the length is approximately 21.6km. The structure consists of elevated and at grade segments.

From St5 to St18 will be opened in 2018 as Stage 1 and the rest will be opened in 2020 as Stage 2.

In Hinjawadi IT Park there are two options for construction from St20 to St21. Option 1 is at grade and Option 2 is elevated.

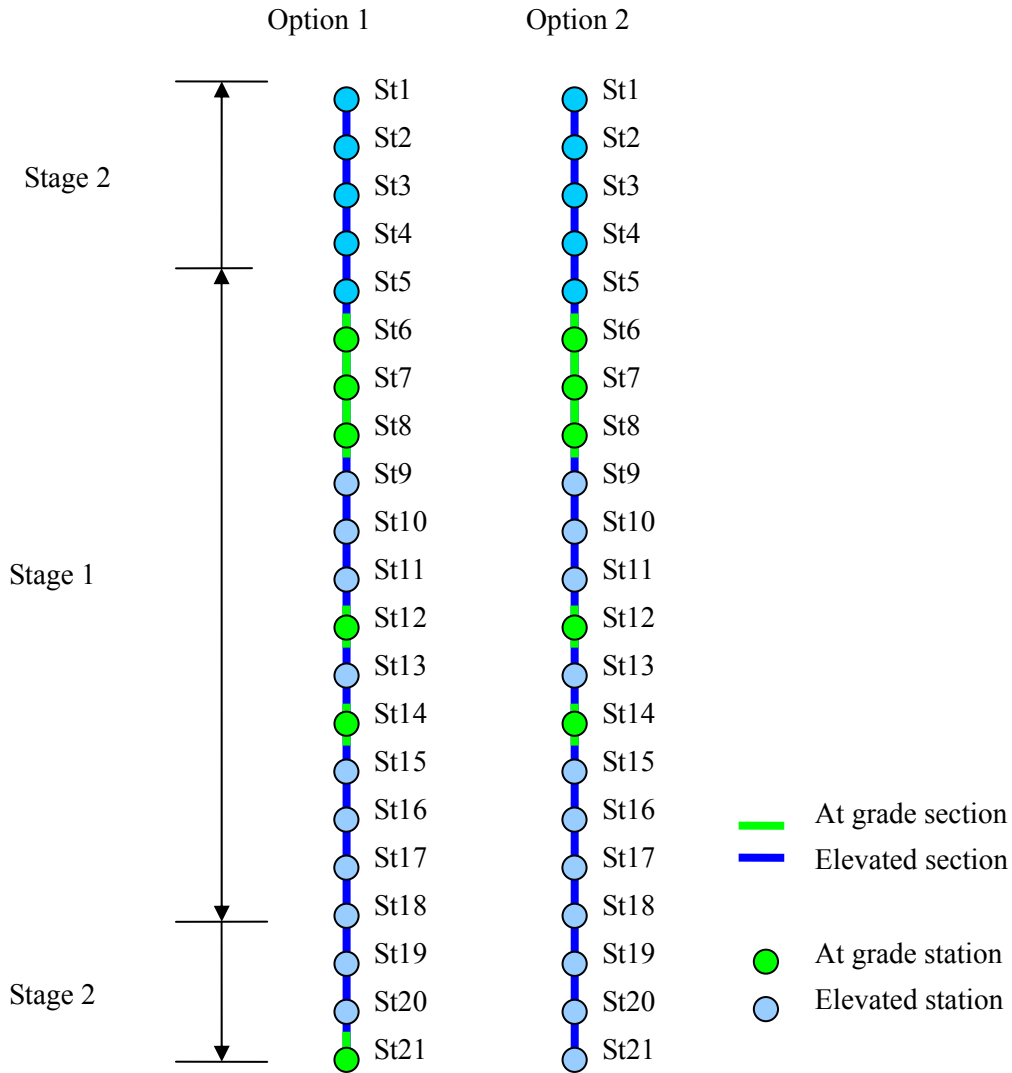

**Figure 5.3.1** Route of the Line

Source: JICA Study Team

**Demand Forecast**

The forecast number of passengers at peak section in peak hour per direction (PPHPD) is indicated in Table 5.3.1. Train operation is planned based on PPHPD.

**Table 5.3.1** Demand forecast

Year	2018	2028	2038
Demand forecast (PPHPD)	6,978	10,865	15,102

Source: JICA Study Team

**Train Capacity**

Specification of the rolling stock is indicated in chapter 5.5.2 of this report. Capacity of one train set is 460 passengers with seating and 4 persons per square meter standing. Transportation capacity is estimated at 150% of this capacity that is 690 passengers per train.

Head way and transportation capacity of the peak hour is indicated in Table 5.3.2.

**Table 5.3.2 Transportation capacity per hour**

Headway (min)	10	8	6	5	4	3.3	3	2.5
Trains per hour	6	7.5	10	12	15	18	20	24
Capacity (persons/hour)	4,140	5,175	6,900	8,280	10,350	12,420	13,800	16,560

Source: JICA Study Team

Based on the demand forecast and train capacity, the headway of peak hour in each year is decided as follows. There is no demand forecast for years 2023 and 2033, it is assumed that demand will increase at equal rate.

**Table 5.3.3 Headway and Transportation Capacity**

Year	2018	2023	2028	2033	2038
Demand Forecast (PPHPD)	6,978	8,695	10,865	12,780	15,102
Operational Headway	5	4	3.3	3	2.5
Transportation Capacity	8,280	10,350	12,420	13,800	16,560

Source: JICA Study Team

**Running Time**

Running time is calculated by simulation based on rolling stock performance and route data and regular running time is decided by the time calculated by the simulation. Maximum speed is set as follows.

Elevated section      80km/h

At grade section      50km/h

In elevated sections it is difficult for people or cars get onto the track so maximum speed is set at 80km/h which is the maximum specified speed of the rolling stock. At grade section track will be segregated by fences but there will be the possibility that people or cars will get onto the track so maximum track speed will be limited to 50km/h.

Regular running time of each station in option 1 is indicated in Table 5.3.4 and Table 5.3.5

**Table 5.3.4 Regular running Time (Outbound)**

Station	Dwell time	Running time	Arrival	Departure
St1			---	0:00:00
St2	30	1:30	0:01:30	0:02:00
St3	30	0:45	0:02:45	0:03:15
St4	30	1:20	0:04:35	0:05:05
St5	30	0:50	0:05:55	0:06:25
St6	30	1:45	0:08:10	0:08:40
St7	30	1:00	0:09:40	0:10:10
St8	30	1:15	0:11:25	0:11:55
St9	30	1:00	0:12:55	0:13:25
St10	30	1:10	0:14:35	0:15:05
St11	30	2:35	0:17:40	0:18:10
St12	30	1:40	0:19:50	0:20:20
St13	30	2:10	0:22:30	0:23:00
St14	30	1:15	0:24:15	0:24:45
St15	30	2:10	0:26:55	0:27:25
St16	30	2:25	0:29:50	0:30:20
St17	30	1:10	0:31:30	0:32:00
St18	30	2:10	0:34:10	0:34:40
St19	30	1:10	0:35:50	0:36:20
St20	30	1:45	0:38:05	0:38:35
St21		4:25	0:43:00	---

Source: JICA Study Team

**Table 5.3.5 Regular running Time (Inbound)**

Station	Dwell time	Running time	Arrival	Departure
St21			---	0:00:00
St20	30	4:25	0:04:25	0:04:55
St19	30	1:45	0:06:40	0:07:10
St18	30	1:10	0:08:20	0:08:50
St17	30	2:15	0:11:05	0:11:35
St16	30	1:10	0:12:45	0:13:15
St15	30	2:25	0:15:40	0:16:10
St14	30	2:10	0:18:20	0:18:50
St13	30	1:25	0:20:15	0:20:45
St12	30	2:10	0:22:55	0:23:25
St11	30	1:40	0:25:05	0:25:35
St10	30	2:40	0:28:15	0:28:45
St9	30	1:05	0:29:50	0:30:20
St8	30	0:55	0:31:15	0:31:45
St7	30	1:15	0:33:00	0:33:30
St6	30	1:00	0:34:30	0:35:00
St5	30	1:45	0:36:45	0:37:15
St4	30	0:50	0:38:05	0:38:35
St3	30	1:20	0:39:55	0:40:25
St2	30	0:45	0:41:10	0:41:40
St1		1:25	0:43:05	---

Source: JICA Study Team

In Option 2 running time between St20 and St21 will be 1 minute shorter. Total running time becomes 42 minutes in outbound and 42 minutes and 5 seconds in inbound.

**Track Layout of Terminal Station**

Track layout of each terminal station is indicated in Figure 5.3.2 to Figure 5.3.6.

**St1**

St1 is the terminal for the Centre of Pune. The trains will arrive at either the upper track or the lower track and the passengers alight and load and depart from the same track.

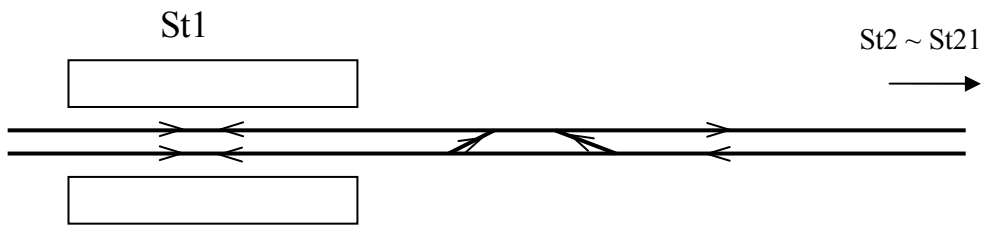
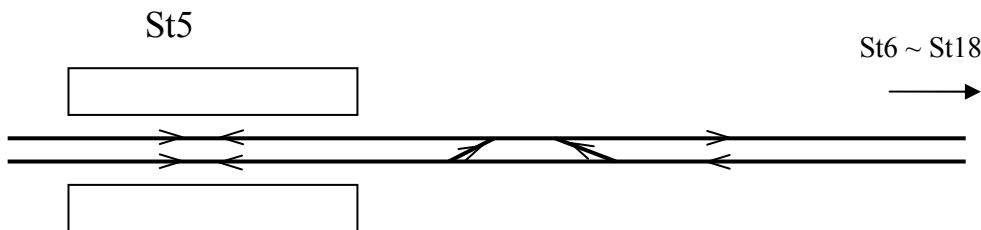

**Figure 5.3.2 Track Layout of St1**

Source: JICA Study Team

**St5**

St5 will be the terminal station at Stage 1 and track layout is the same as St1. After opening of the entire section, a cross over will be used for the train to turn back in an emergency.

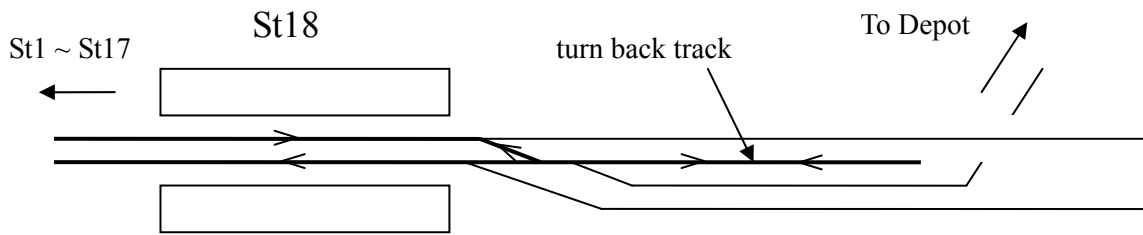

**Figure 5.3.3 Track Layout of St5**

Source: JICA Study Team

**St18**

St18 will be the terminal station at Stage 1. A turn back track will be provided at the west end of St18. Train arriving will disembark the passengers and will move to the turn back track and back to the opposite side platform of the station to load the passengers.



**Figure 5.3.4 Track Layout of St18**

Source: JICA Study Team

**St21**

St 21 is the terminal station of Hinjawadi. Track layout will be different in the at-grade station and elevated station.

In Option 1 St 21 will be an at grade station. There is not enough space for a turn back track, therefore, a cross over will be provided before the station. Trains will double back directly from the platform.

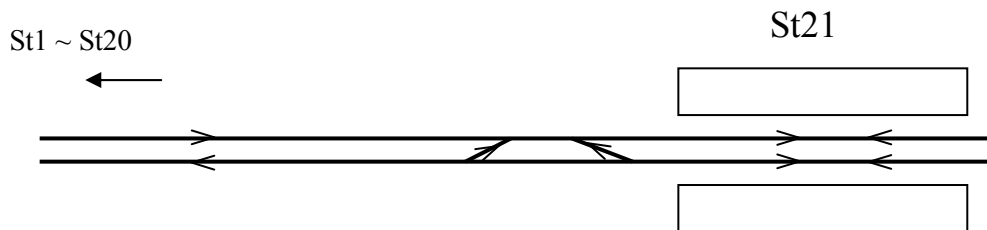

**Figure 5.3.5 Track Layout of St 21(at grade)**

Source: JICA Study Team

In Option 2 the station is elevated and turn back tracks are provided at the back of the station.

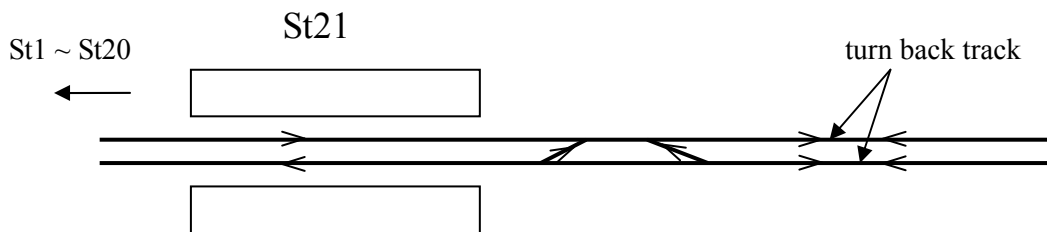

**Figure 5.3.6 Track layout of St 21 (elevated)**

Source: JICA Study Team

**Turn Back Time**

In turning back at a terminal station it is assumed that it will take 30 seconds for alighting, 30 seconds for loading and 1 minute for changing the cab at the minimum. When there is a cross over in front of the station and trains will turn back directly at the station changing cab can be done at the same time as alighting and loading, 1 minute is assumed as the minimum time. When there are



turn back tracks at the back of the station it is assumed 30 seconds for moving from station to turn back track, minimum 3 minutes will be assumed for turning back.

Based on the regular running time and turn back time, round trip time is assumed as follows.

**Table 5.3.6 Round Trip Time**

	Stage 1 (St5-St18)	Stage 2 (St1-St21)	
		Option 1 (St20-St21 at grade)	Option 2 (St20-St21elevated)
running time outbound	27min. 5sec.	43 min.	42 min.
turn back time (St18,St21)	3 min.	1 min.	3 min.
running time inbound	27min. 55sec.	43 min. 5 sec.	42 min. 5 sec.
turn back time (St1,St5)	1 min.	1 min.	1 min.
round trip time	59 min. 10 sec.	88 min. 5 sec.	88 min. 5 sec.

Source: JICA Study Team

### **Rolling Stock Procurement Plan**

Required number of trains to operate at peak hour in each year become as shown in the following table.

**Table 5.3.7 Required Number of Trains in Operation**

		2018	2020	2023	2028	2033	2038	
Headway in Peak Hour		5	5	4	3.3	3	2.5	
Number of Trains in Peak Hour		12	12	15	18	20	24	
Required Number of Train Sets in Operation	Stage 1	13	-	-	-	-	-	
	Stage 2	Option 1	-	18	23	27	30	36
		Option 2	-	18	23	27	30	36

Source: JICA Study Team

Required number of train sets including reserved trains is indicated in Table 5.3.8. Reserved number of trains is assumed to be 8% for reserved for inspection and 1 train for contingency.

**Table 5.3.8 Required Number of Train sets**

	2018	2020	2023	2028	2033	2038
Trains in Operation	13	18	23	27	30	36
Reserved Trains	3	3	3	4	4	4
Total Number of Trains	16	21	26	31	34	40

### **Operation Hours**

Operation hours will be 6:00 to 24:00. Peak hours to operate maximum number of trains will be 7:00 to 9:00 in the morning and 17:00 to 19:00 in the evening. In off peak, the number of trains will be half of peak hours.

## **Operation in Emergency**

Operation procedure in an emergency such as rolling stock failure will be as follows.

### **Propulsion failure**

One unit fails

Operate until the terminal and deadhead to depot.

Two units up to half of the trains fail

Operate to nearest station and evacuate the passengers then deadhead to depot.

More than half of the trains fail

Rescue by following revenue train and pushed to next station. After evacuating passengers of both trains, deadhead to depot.

### **Brake System Failure**

One unit up to half of the trains fail

Operate to nearest station and evacuate the passengers then deadhead to depot.

More than half of the trains fail

Rescued by following revenue train and pushed to next station. After evacuating passengers of both train deadhead to depot.

### **Required performance of rolling stock for emergency**

To meet the procedures above, the following performance is required of the rolling stock.

Train can start at maximum gradient with cutting out one propulsion unit with full loading (150% of capacity).

Train can operate without affecting the schedule with cutting out one propulsion unit by turning on the high acceleration switch.

Train can start at maximum gradient with cutting out half of the propulsion units with full loading.

Train is capable of pushing or pulling another defective train with full loading at maximum gradient.

## **5.4 Civil Engineering Facilities Plan**

Since Dehli Metro which was opened for the passenger in 2002 is the first best model project except Kolkata Metro project opened in 1984, the Dehli Metro project is the design standard and quality standard for a urban railroad project in India.

The railroad project of other cities is actually drawing up the Detailed Project Report (DPR) of

feasibility study referred to Dehli Metro project. On the other hand, Pune LRT project applies another railway standard due to different system from a Dehli metro project.

Design basis are set up to design the civil engineering facility and shown in Table 5.4.1.

**Table 5.4.1 Design Basis for Civil Engineering Facility Plan**

Items		Design basis
Length of track gauge		1,435mm (Standard gauge)
Distance between the tracks		3,050mm (Straight section)
Width limit of LRT		2,650mm
Height limit of LRT		3,800mm
Width of architectural restrictions		3,450mm
Platform length	Ground station	62m
	Elevated station	65m
Platform width	Ground station	2.5~3.0m
	Elevated station	4.0~5.0m (including the steps and escalator facilities)

Source: JICA Study Team

In the elevated part, space 800mm wide is designed for the maintenance and escape roads along the railway line and for the signals and communication line boxes. Section size for a single track line is shown in Figure 5.4.1 and section size for a double track line is shown in Figure 5.4.2.

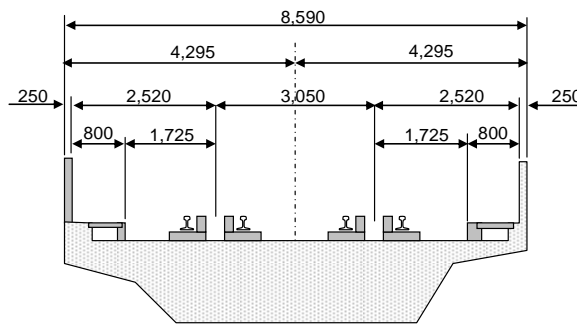

**Figure 5.4.1 Section Size of Double Track Line (unit: mm)**

Source: JICA Study Team

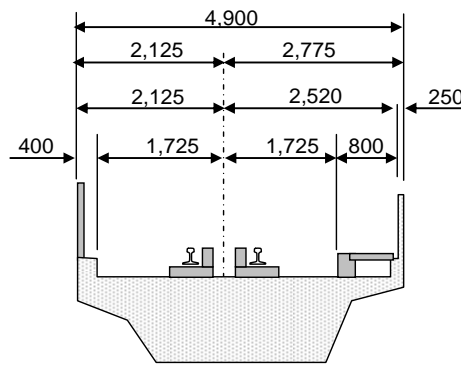

**Figure 5.4.2 Section Size of Single Track Line (unit: mm)**

Source: JICA Study Team

As discussed in 5.1.1, basically civil engineering facilities will be constructed in the public space, and the structures will be designed to minimize the effect on the road traffic. The basic structures for elevated sections and ground sections that are selected in section 5.1.2 2) are shown below.

#### **5.4.1 Elevated Area**

Basic required conditions of the Construction plan of the elevated structure inside urban areas are as follows.

- In considering prioritization of local material procurement and use of conventional technology, the elevated structure is planned to be built from Reinforced Concrete and Pre-stressed Concrete.
- To shorten the construction period, typical structure design such as uniformed span or same-sized structure elements, is established.
- So as to not to impair existing road traffic function, the scale of the substructure and foundation should be designed as small as possible.
- The construction method which does not restrain existing traffic as possible should be adopted.

##### **1) Superstructure**

From the view point of scale of the substructure, the rail-train load and scale of girder erection equipment, the typical span of the elevated railway structure is set at 25 m.

As the result of the study of comparison of superstructures shown in the next page, PC Box Girder is proposed for the Superstructure Type.

##### **2) Substructure and Foundation**

In order to make the area occupied by the completed structure and construction work as small as possible, the pier shape is designed as a single column type.

From the result of the geological survey, it is found that the rock stratum, which is able to firmly support the load of elevated structure, is below about 5m from ground surface. Accordingly, a spread-foundation may be adapted, after replacement of existing soil with aggregate. The PC-well type foundation, which is able to be built without temporary walls for excavation, is employed.

**Table 5.4.2 1st Comparison Table of Superstructure Type for Elevated Section**

Bridg Type	Erection Method	Applicable Span Length (m)	Girder Height/Span)	Feature	Applicability
Reinforced Concrete Girder	Cast-on-stage		1/11 ~ 1/16	Inappropriate for middle and longer span length	<b>Not adopted</b>
Prestressed Concrete Girder	Crane Erection girder		1/14 ~ 1/18	Inappropriate for curved structure	<b>Not adopted</b>
	Cast-on-stage		1/20 ~ 1/24		Extracted for 2nd Comparison
	Cast-on-stage		1/16 ~ 1/25		Extracted for 2nd Comparison
Steel Girder	Precast Segment		1/17 ~ 1/23		Extracted for 2nd Comparison
	Cantilever method		1/18 ~ 1/36	High cost relatively	Possible depend on site condition
Steel Girder	stage and crane		1/16 ~ 1/20	Inappropriate for curved structure	<b>Not adopted</b>
	stage and crane		1/16 ~ 1/25	High cost relatively	Extracted for 2nd Comparison

Legend : Applied Generally : Possible

Source: JICA Study Team

Table 5.4.3 2nd Comparison Table of Superstructure Type for Elevated Section

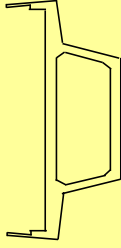
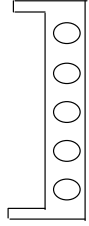
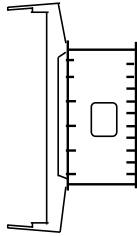
Option	1		2		3	
Superstructure type	PC BOX Girder		PC Hollow Slab Beam Girder		Steel Box Girder	
Outline View						
	Constructability	Adaptation to curved structure	Very good	Possible	Normal	Suitable
Resistance of torsion		Very good	Possible	Normal	Suitable	Good
Const.Priod	Construction period is normal		Construction period is normal		Construction period on site is shorter than PC girder. However Fabrication of girder is nececeary at girder	
	Initial cost	1.00	1.00		1.50	
Initial cost and Maintenance cost	-		-		0.30	
	Maintenance cost			Good	Re-painting ,3times in 50years (1 time/10~15years)	
Total Cost	1.00		1.00		1.80	
<b>Overall Evaluation</b>	<b>Proposed</b>					

Source: JICA Study Team

Typical section of elevated railway is shown below.

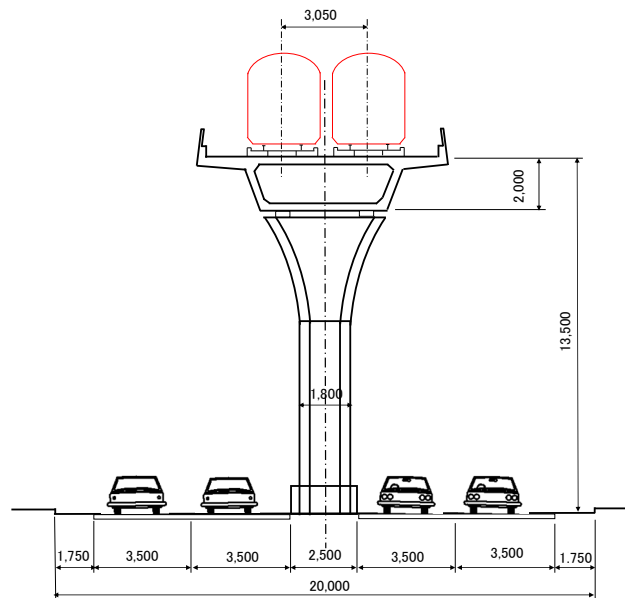

**Figure 5.4.3 Typical Section of Elevated Railway**

Source: JICA Study Team

### 3) Standard Elevated Station

The substructure of the elevated stations shall be a single center pier which supports the platform and concourse the same as the general elevated section. Since the cantilevers which support the concourse and platform are long, pre-stressed concrete is proposed for the cantilevers.

The rail level shall be set at about 13.5 m above the road surface level taking the construction gauge height (clearance 5.5. m or more) for road, girder height, overhead clearance below the girders of the concourse floor, and track height into account. The width of a station shall be set at 15 to 17 m taking the platform width of 4 to 5 m (including stairs and escalator) and double track width of 5.8 m into account. Platform length shall be set at 65 m taking one train length of 60 m and allowance length of 5 m into account. The concourses shall be constructed for the stations used by many passengers, but they shall not be constructed for the stations used by few passengers, which will be provided with simplified passenger loading facilities. Installation of elevators and escalators in each station are shown in the Table 5.4.4.

**Table 5.4.4 Lift equipment to be installed in each station**

Station	Equipments to be installed	Station	Equipments to be installed	Station	Equipments to be installed
St. 1	Escalator, Elevator	St. 8	-	St. 15	Escalator, Elevator
St. 2	Escalator, Elevator	St. 9	Elevator	St. 16	Elevator
St. 3	Elevator	St. 10	Elevator	St. 17	Elevator
St. 4	Elevator	St. 11	Escalator, Elevator	St. 18	Escalator, Elevator
St. 5	Elevator	St. 12	-	St. 19	Elevator
St. 6	-	St. 13	Elevator	St. 20	Elevator
St. 7	-	St. 14	-	St. 21	Elevator (in case of elevated structure)

Source: JICA Study Team

The drawing shown in Figure 5.4.4 is the standard cross section of an elevated station and pedestrian deck and stairways which connect the concourse level and sidewalk may be required depending on the situation.

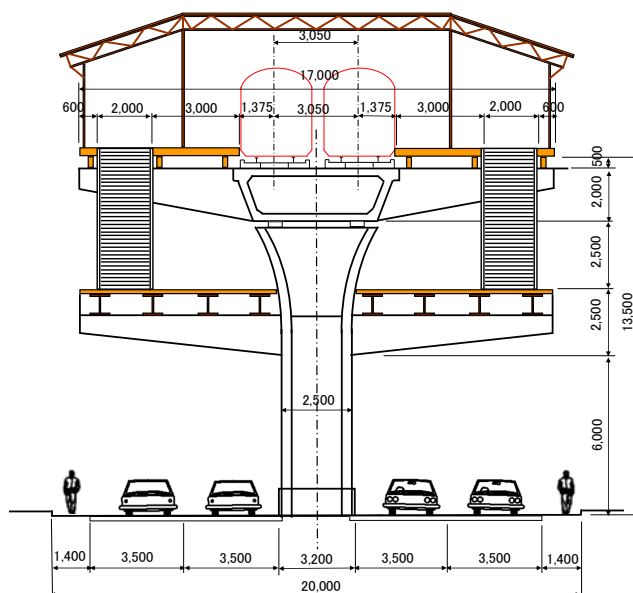
**Figure 5.4.4 Elevated Station Standard Cross Section**

Source: JICA Study Team

#### 4) Study and Positioning the Location of Station-1; JM TEMPLE

##### (1) Required Conditions for Positioning the Location of Station-1; JM TEMPLE

Station-1(JM TEPMLE) is the starting station, and is planned to be built in the central part of Pune City. To finalize the exact location of station-1, required conditions for positioning of station-1 definitively are shown as follows:

- ✓ To be most convenient for passenger access to the main facilities, for example, public facilities and large commercial stores in the city center.
- ✓ To be easy for passengers to move from the road to concourse floor and platform floor.



- ✓ To be easy and convenient for passengers transferring to the Station of the Pune City Metro Line 2.
- ✓ To be a moderate structural plan for construction.
- ✓ To take into account the doubling back for trains arriving at the starting station.

**Examination of Extracted Location**

The following 3 options were examined and compared.

**Option 1: Positioning at Shivaj Maharaj Road**

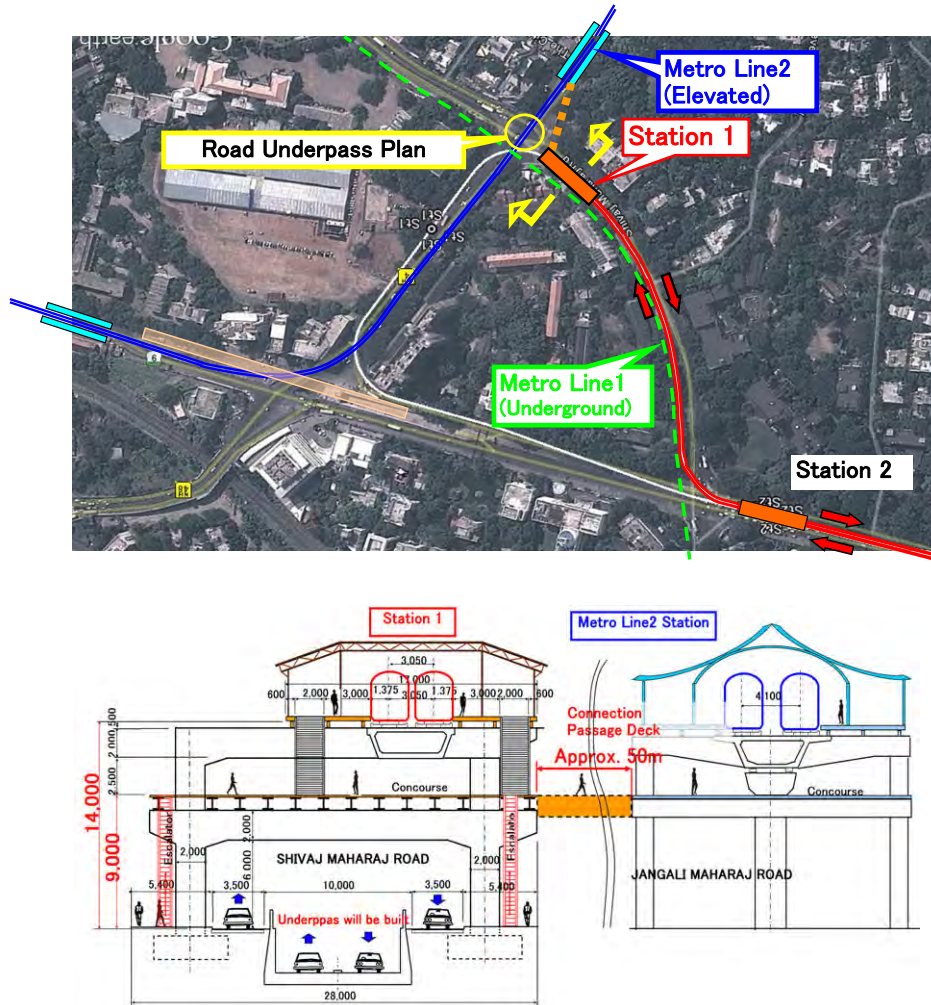

**Figure 5.4.5 Plan and Section of Option-1**

Source: JICA Study Team

**Evaluations**

- ✓ Location Condition: Positioning at the most central area in the city. (Very good)
- ✓ Convenience for Passengers: Easy to rise from road level to concourse and platform floor. (Good). Normal height between concourse floor and platform floor (Good).
- ✓ Convenience and easy to transfer to Metro station: Short distance to transfer due to positioning near the station of the Pune city Metro Line 2, and same concourse level. (Very good)

- ✓ Structural and constructional plan: The road underpass structure is planned to be built near Station-1, and be completed beforehand. A rigid frame pier structure shall be built over the underpass. There is no difficulty with the construction and structural issues particularly. (Good).
- ✓ The Function of doubling back: A turnout device shall be mounted on the rail near the station. This can be implemented by conventional technology so there is no difficulty. (Good).

**Option 2: Positioning at Jangali Maharaj Road**

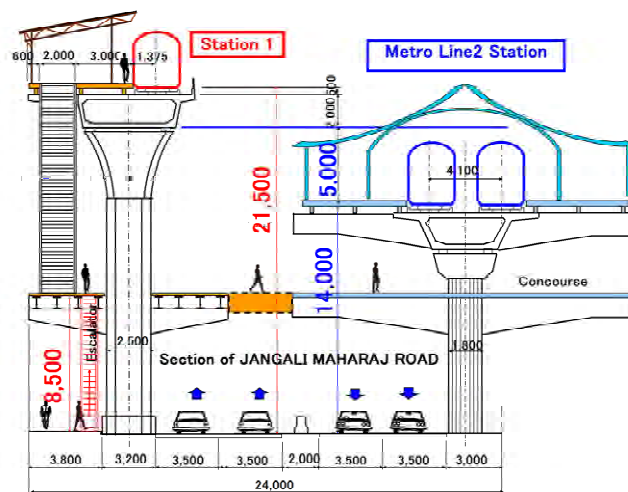
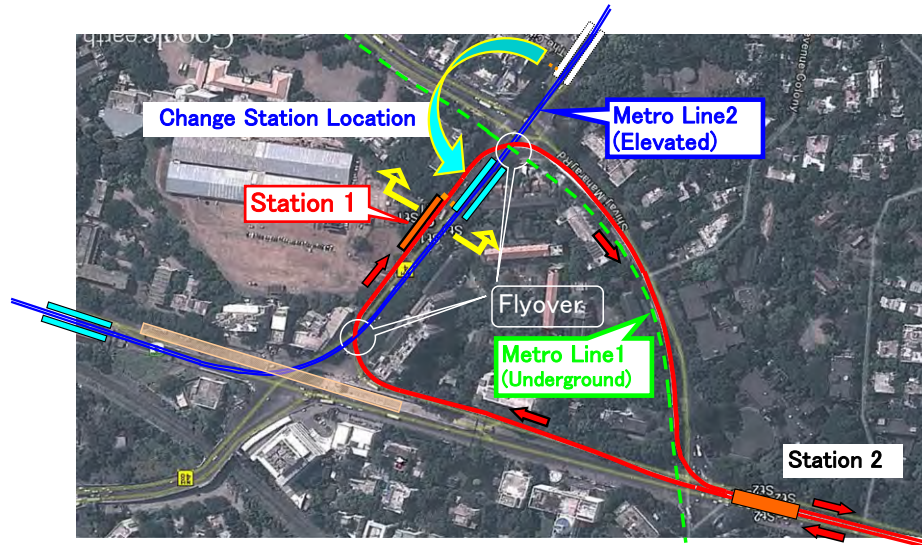

**Figure 5.4.6 Plan and Section of Option-2**

Source: JICA Study Team

**Evaluation**

- ✓ Location Condition: Positioning in the central area of the city. (Good)
- ✓ Convenience for Passengers: Easy to rise from road level to concourse and platform floor. (Good). But, a high climb from concourse to platform floor. (Not good)

- ✓ Convenient and easy for transfer to Metro station: Short distance to transfer due to positioning near the station of the Pune city Metro Line 2. (Good). But, passengers must walk along inclined pedestrian deck for changing levels between both platforms. (Not good)
- ✓ Structural and constructional plan: The height of the Station-1 reaches over 20 m due to the need for a flyover across the viaduct of Metro Line 2. (Not good)
- ✓ The Function of doubling back: Doubling back is operated along the loop. Rail structure is simple, but if an accident happens on the loop, the problem remains until repairs are completed. (Not good)

**Option 3: Positioning at Samgaam Bridge Road**

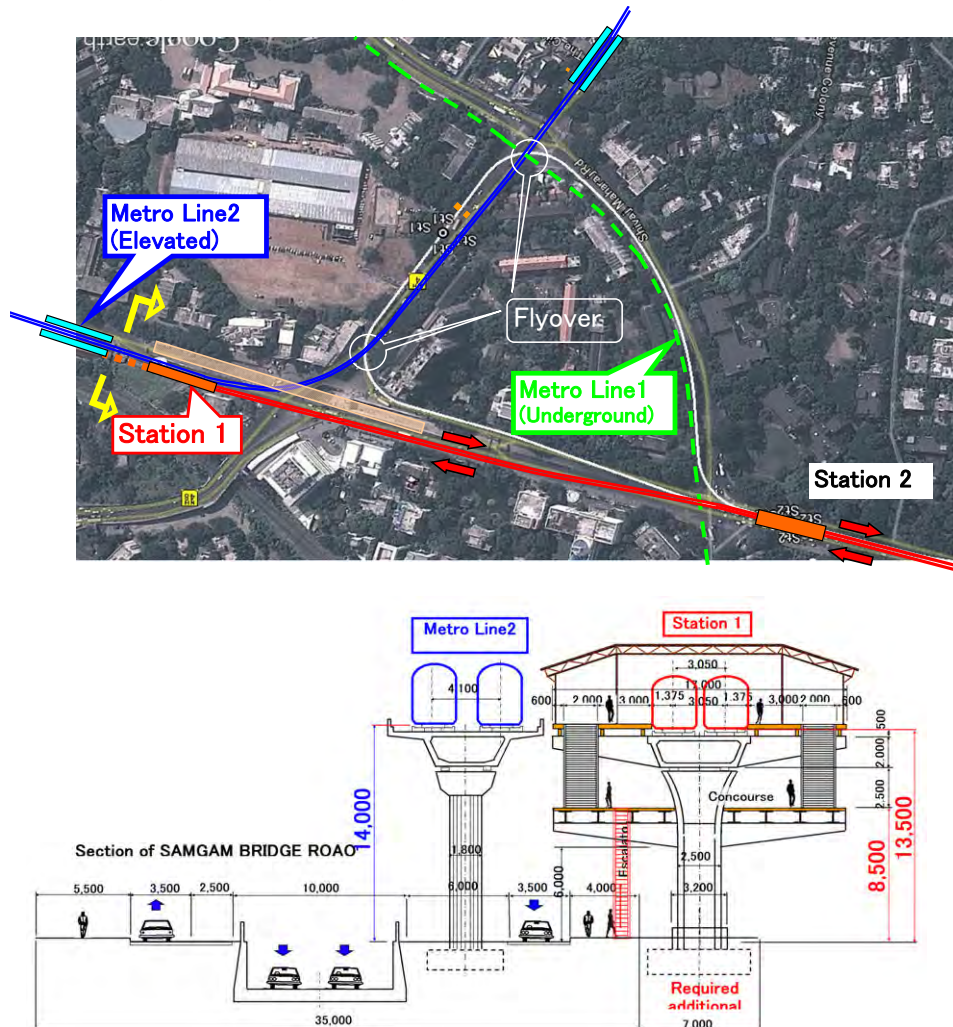

**Figure 5.4.7 Plan and Section of Option-3**

Source: JICA Study Team

**Evaluation**

- ✓ Location Condition: Positioning outside the central area of the city. (Not good)
- ✓ Convenience for Passengers: Easy to climb from road to concourse floor. (Good). Normal height from concourse floor to platform floor (Good).

- ✓ Convenient and easy to transfer to Metro station: Short distance to transfer due positioning near the station of the Pune city Metro Line 2, and same concourse level. (Very good)
- ✓ Structural and constructional plan: Typical elevated station structure (good) can be adopted, but additional land acquisition is required outside of the road to build piers and foundations. (Not good)
- ✓ The Function of doubling back: A turnout device shall be mounted on the rail near the station. This can be implemented by conventional technology so there is no difficulty. (Good).

## (2) Definitive Position of Station-1; JM TEMPLE

As the result of the above examination, it is proven that Option-1 is the most suitable plan considering location, convenience for passengers, ease for transferring, and structural and contractual plan. Accordingly, the location of the Station-1 (JM TEMPLE) in option-1 is proposed.

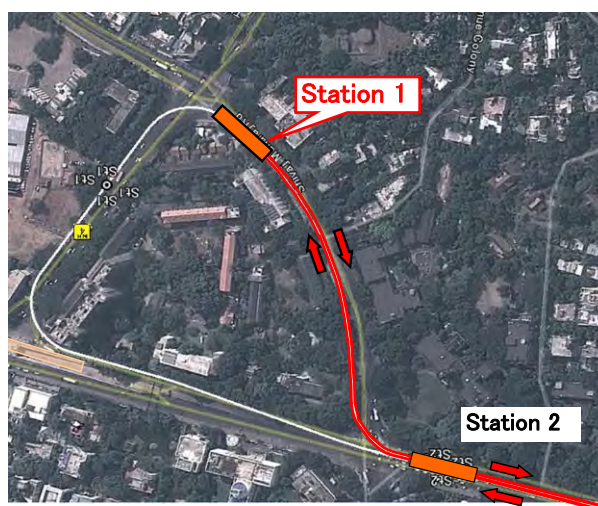

**Figure 5.4.8 Definitive Location of Station-1**

Source: JICA Study Team

## 5) MULA River Bridge

The Bridge over the MULA River is located near Station-10 and is planned to be constructed upstream from the existing Road Bridge crossing the river. Two feasible methods can be planned. One is setting the typical girder span the same as the other elevated sections, and the other is for long continuous girders for the purpose of reducing the number of piers constructed in the river.

## (a) The Plan Setting Typical Girder Spans cross the River

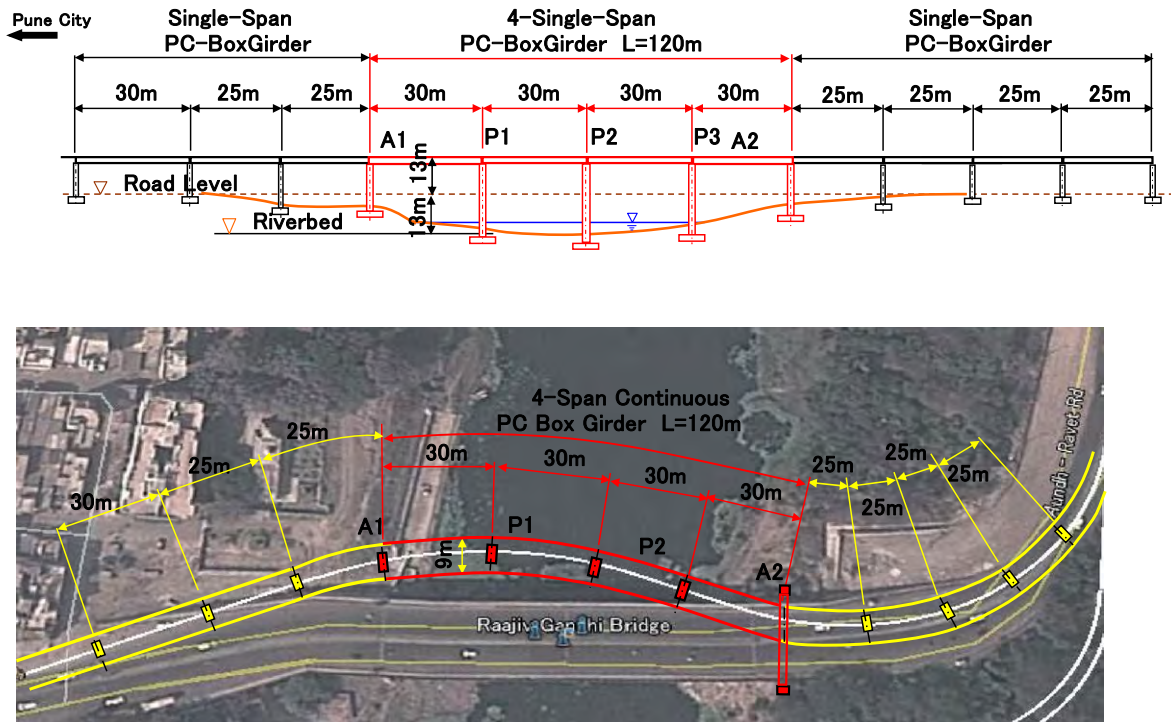

Figure 5.4.9 Profile and Plan of Typical girder span

Source: JICA Study Team

**Technical Features**

- ✓ The equipment for typical PC-box girder for construction of other sections is available for use. (Good)
- ✓ Relatively many substructures and temporary cofferdams are necessary. Construction schedule for Foundation and substructure need a long period (Not Good)
- ✓ Temporary bridge for construction piers and girder erection is required along the whole width of the river. (Not Good)
- ✓ The reduction of the cross-sectional area of the river during the construction is greater. Therefore, it is necessary to confirm the impacts on the river in consultation with the authority of river administration. (Not Good)

## (b) The Plan for Long Continuous Girder cross the River

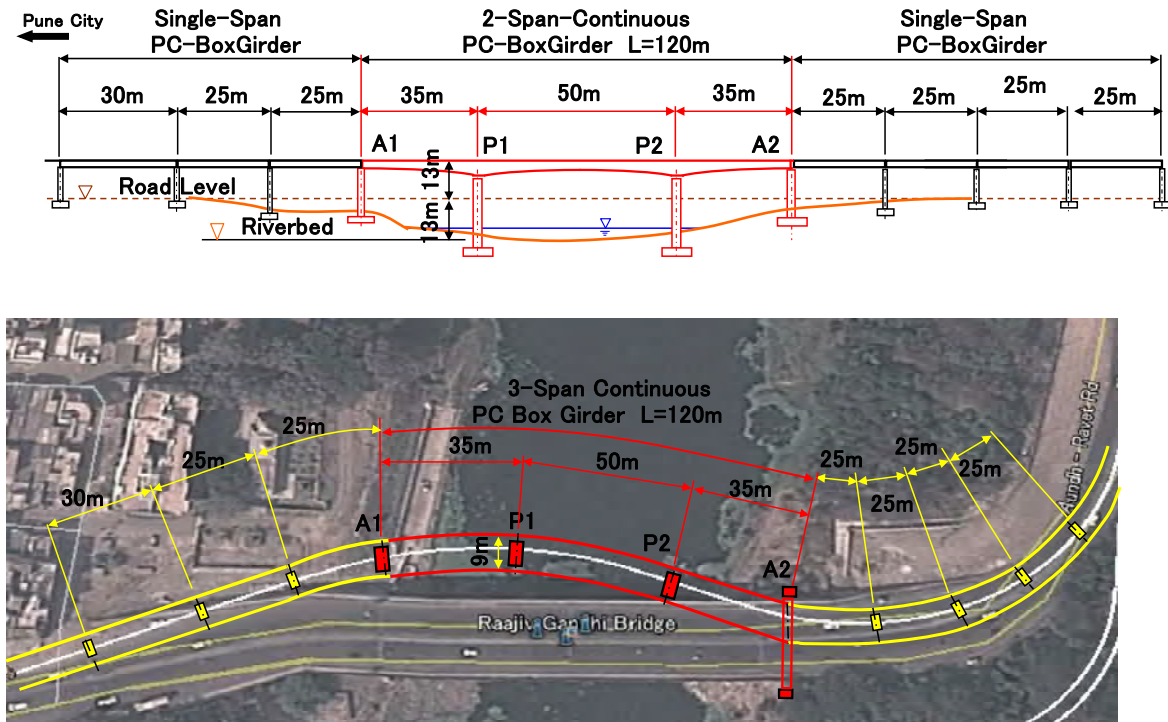

Figure 5.4.10 Profile and Plan of Long Continuous Girder

Source: JICA Study Team

**Technical Features**

- ✓ Cantilever method is the type of the method in which a girder is overhanging and extending from the pier-head sequentially using a temporary working-truck. There are a number of proven methods that are employed when the construction space under the girder is not assured. (Good)
- ✓ Since special equipment is needed for the cantilever, construction of the superstructure costs more than plan (a). (Not Good)
- ✓ Length of the temporary bridge is about half of the width of the river because there is only one pier in the river. The reduction of the cross-sectional area of the river is small; to the impact on the river is small during construction. (Good)
- ✓ While there is only one Pier, the scale of the temporary cofferdam becomes larger. (Not Good)

Detail survey and study for the bridge crossing the river will be implemented in a coming step of the basic design phase and detail design phase, meeting with the authority of river administration. After that, details of the bridge will be defined.

The meeting with the river administration authority will discuss:

- ✓ To confirm accumulated water level records for the past at the cross section of the river where the new bridge will be constructed.

- ✓ To confirm whether further rehabilitation plans for the river are established or not
- ✓ To confirm obtaining of permission for using the area inside the river to construct the new bridge
- ✓ To confirm the possibility of the working in the area inside the river during the rainy season, and documents that shall be submitted to the river administration authority for obtaining the approval of the work.

## 5.4.2 At-grade Section

### 1) General at-grade section

The LRT shall run on both sides of the road and fences shall be constructed on both sides of the carriageway side and footpath side to avoid entering of vehicles and pedestrians. The general cross section is shown in Figure 5.4.11 and Figure 5.4.12. Regarding the structure of the track refer to 5.5.1 Track Facility.

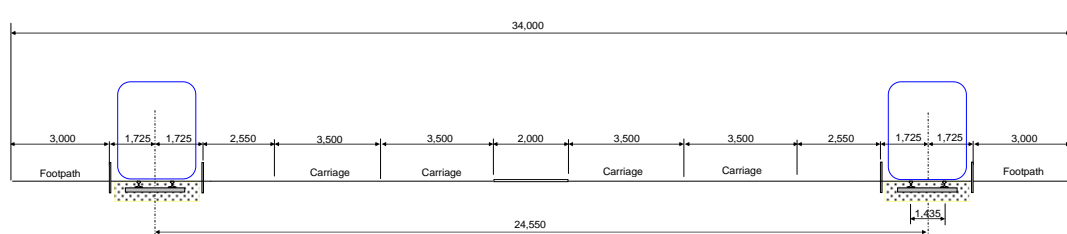

Figure 5.4.11 General at-grade Section in PMC (Unit: mm)

Source: JICA Study Team

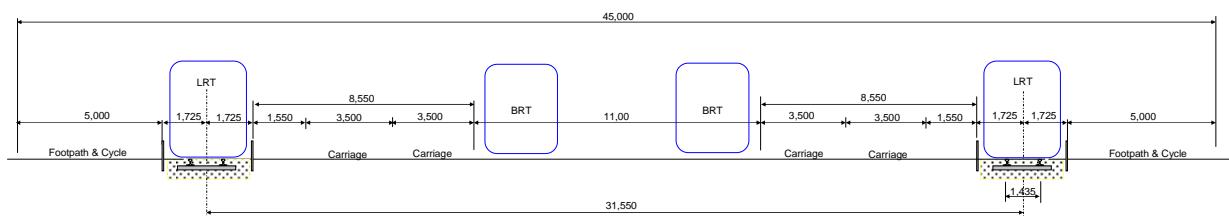

Figure 5.4.12 General at-grade Section in PCMC (Unit: mm)

Source: JICA Study Team

### 2) At-grade Station

Platforms will be constructed on the both sides of the road for at-grade stations. The width of a platform shall be 2.5 to 3.0 m and the length of the platform shall be 62 m taking train length of 60 m and allowance length of 2 m into account. The height of the platform must be adjusted for the specifications of the rolling stock and 300 mm or less is proposed for the height. General cross sections for at-grade stations are shown in Figure 5.4.13 and Figure 5.4.14.

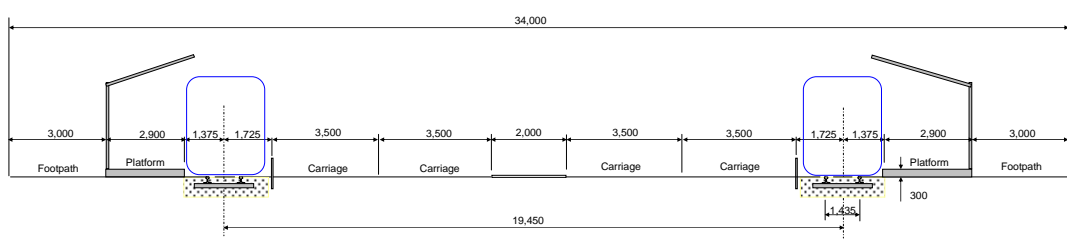

Figure 5.4.13 At-grade Station in PMC (Unit: mm)

Source: JICA Study Team

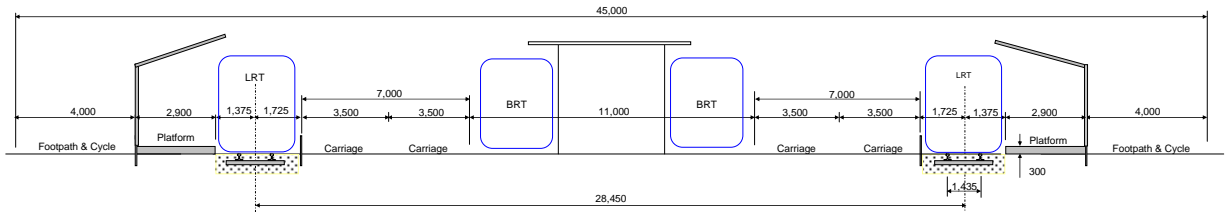

Figure 5.4.14 At-grade Station in PCMC (Unit: mm)

Source: JICA Study Team

### 3) The Method of Traffic Control in the Intersection

The railway is planned to cross an intersection near station-12. A traffic signal system would be employed to control the Vehicles crossing the railway and to prioritize railway traffic across the intersection.

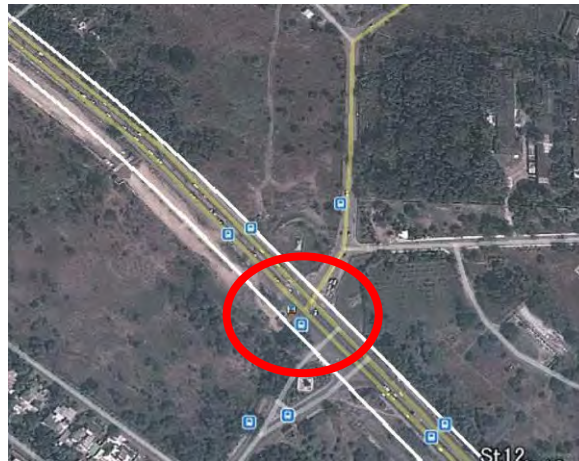
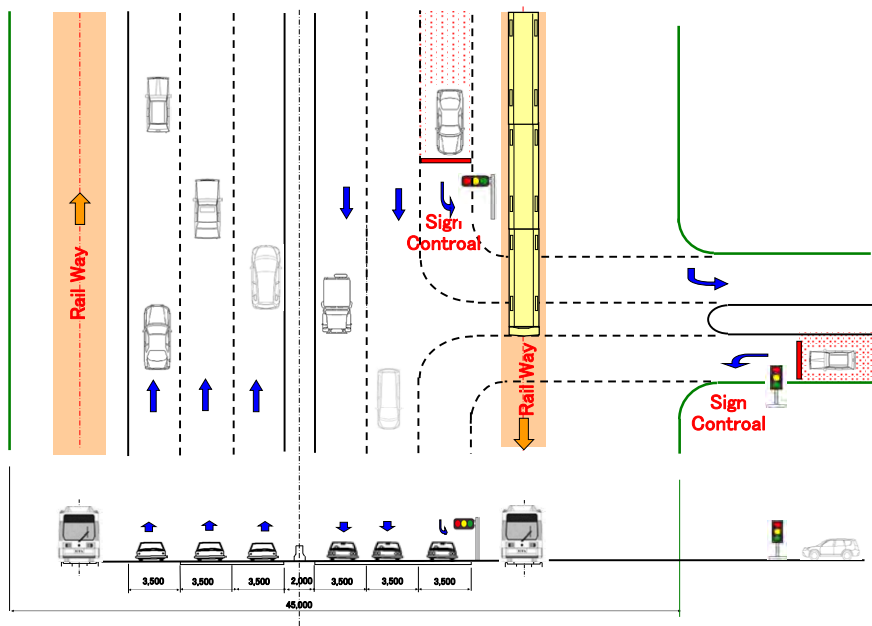

Figure 5.4.15 Location of Intersection

Source: JICA Study Team





**Figure 5.4.16 Traffic Control Plan in Intersection**

Source: JICA Study Team

### 5.4.3 Depot and Workshop

A depot and workshop will be provided beside the line. The depot is for stabling and light maintenance of rolling stock and the workshop is for heavy maintenance of rolling stock. Maintenance of the main tracks will be conducted at night while service is suspended. The fleet of the trains should be stabled in the depot so that the track is cleared for maintenance work and for passing of maintenance vehicles in the night.

#### Location of the Depot

The depot requires a huge land space more than 11 ha for stabling all the rolling stock and its maintenance. The candidate for the location is south of St 18. The area adjacent to St18 in the depot complex is also planned for commercial space and office space.

Access track to the depot is branched from west of St18 and from where it drops down and crosses under the elevated main line with grade separation.

#### Facilities of Rolling Stock Depot and Workshop

The following facilities and tracks will be provided in the rolling stock depot.

- Stabling tracks: for storage of trains
- Inspection track: for regular inspection and occasional repair of rolling stock
- Washing track: for manual washing of the trains
- Train washing plant: to wash the outside of the train automatically by passing through an automated train wash machine

- Wheel re-profiling machine: to re-profile the wheel tread without dismantling the wheel set
- Mounting and dismounting track: for mounting/dismounting the bogies to/from the body.  
The track will have a pit and lifting jacks and will be provided in the workshop
- Stabling track for maintenance vehicles: for storage of trackwork vehicles
- Shed for road rail vehicle: for storage and maintenance of road rail vehicle that will be used for track maintenance and emergency rescue

### **Maintenance of Rolling Stock**

Maintenance of Rolling Stock is classified as follows.

- Pre-departure inspection (daily inspection): check the function for running
- Regular inspection (monthly inspection): checking condition and function of major devices.
- Important parts inspection (semi overhaul): detaching important parts such as bogies and brake equipment to inspect and restore
- General inspection (overhaul): disassemble all the major parts to inspect and restore

Interval and duration of each maintenance item is indicated in Table 5.4.5.

**Table 5.4.5 Interval and Duration of Inspection**

Class	Interval	Duration
Pre-departure inspection	One day	1 hour
Regular inspection	3 months	8 hours
Important parts inspection	3 years	20 days
General inspection	6 years	30 days

Source: JICA Study Team

### **Number of Tracks for Storage and Inspection**

The depot and workshop are planned to have enough inspection and storage tracks for year 2038 when the number of train sets will be 40.

Required number of tracks for inspection becomes as follows.

**Table 5.4.6 Number of Tracks for Storage and Inspection**

Track	Class of inspection	calculation	Required number
Inspection track	Pre-departure inspection	36 trains will be in operation. Peak hours (6 hours/day) are not available for inspection. $36/(24-6)=2$	2
	Regular inspection	$8 \text{ hours} \times 40/90=6 \text{ (hours/day)}$	1
Mounting/dismounting track (workshop)	Important parts inspection	$20 \text{ days} \times 40/(6 \times 365)=0.37$	1
	General inspection	$30 \text{ days} \times 40/(6 \times 365)=0.56$	

Source: JICA Study Team

Required number of inspection tracks is 3, however, including occasional inspections 4 tracks are required.

Interval of important parts inspection is 3 years, however, general inspection is required every 6 years, therefore, the actual interval of important parts inspection becomes 6 years. Required number of tracks in the workshop becomes 0.92. tracks for 1 train may be enough but it is difficult to plan the schedule of heavy maintenance without idling time.

Including occasional repair tracks for 2 trains will be required for the workshop.

Based on the calculation above the following number of tracks will be provided.

Stabling track:	2 train sets x 18 tracks
Washing track:	2 train sets x 2 tracks
Inspection track:	4 tracks
Mounting/dismounting track:	1 car x 4 tracks

Considering the increase of passengers after 2038, the number of trains will increase by reducing the headway, therefore, space on the stabling track for 10 more train sets is provided. Layout of Depot is indicated in Figure 5.4.17.

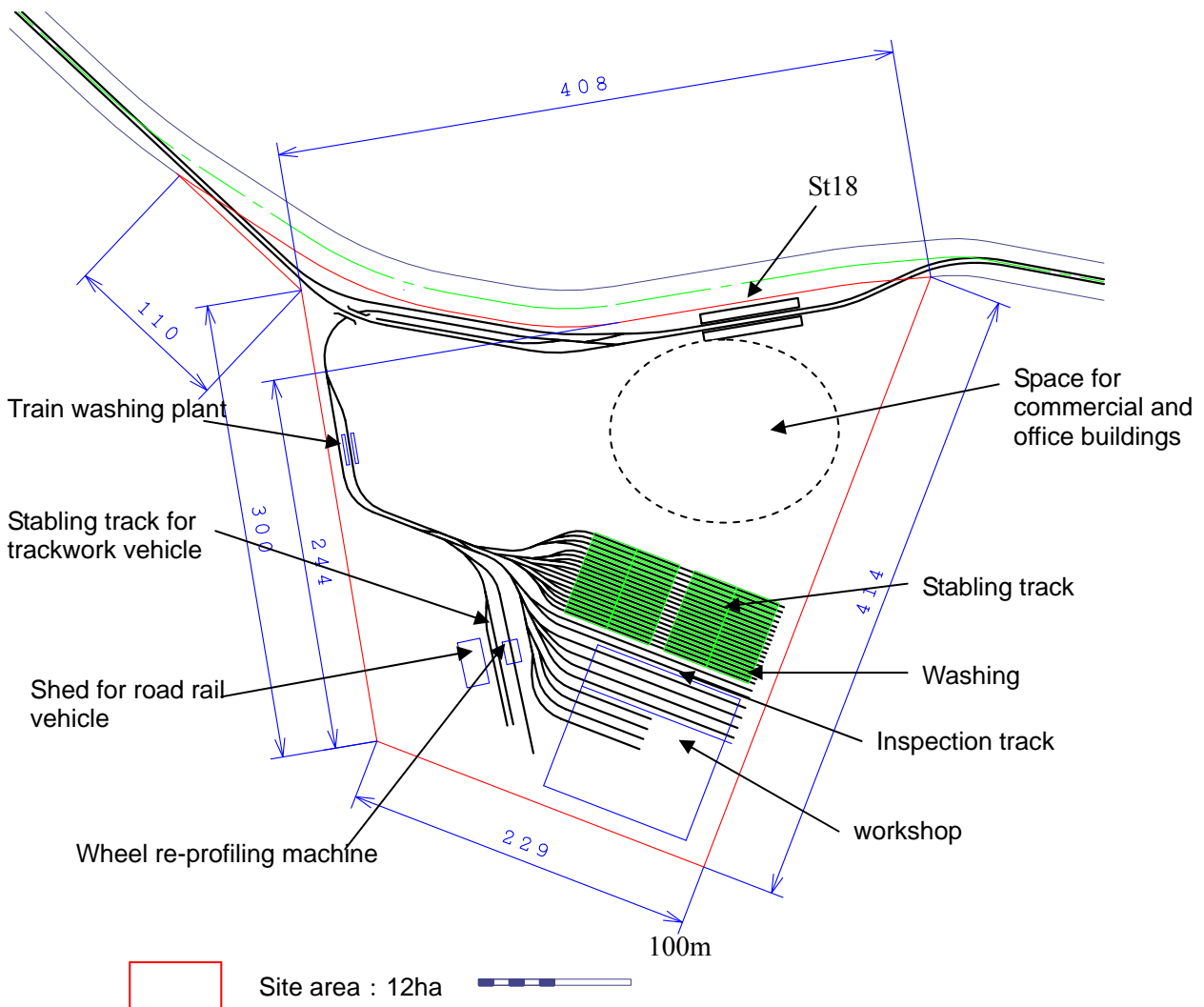

**Figure 5.4.17 Layout of depot and workshop**

Source: JICA Study Team

**Maintenance of the tracks**

Vehicles for trackwork will be stabled in the same complex in the rolling stock depot and workshop.

The following vehicles will be prepared for trackwork

- Flat wagon: for carrying the materials for trackwork
- Track inspection car: measuring the alignment of the track
- Road rail vehicle: vehicle that can run on both road and rail. Will be used for hauling the flat car or LRT trains.

Figure 5.4.18 shows a sample of a road rail vehicle.



**Figure 5.4.18 Sample of Road Rail Vehicle (Manila LRT Line 1)**

Source: The photo was taken by JICA Study Team

## **5.5 Railway Systems**

### **5.5.1 Overall System Concepts**

#### **1) Selection of Optimum Transportation System**

##### **<Future Demand Forecast>**

In response to the result of the future demand forecast discussed in Chapter 3, it is projected that peak-hour passenger demand (PPHPD) will be approximately 7,000 persons in 2018 and 15,000 persons in 2038.

The “Detailed Project Report on Pune Metro Project” (July 2009) by Delhi Metro Rail Corporation mentions that *Experience has shown that in mixed traffic conditions, comprising slow and fast moving traffic prevailing in most of our cities, road buses can optimally carry 8,000 persons per hour per direction.* Bus-based transportation system could be suitable for traffic density with less than 8,000 persons per hour.

As shown in the following figure quoted from the Ministry of Land, Infrastructure, Transport and Tourism in Japan, it describes the optimum transportation system in relation with PPHPD and Operation Speed. Passenger demand for the proposed corridor is suitable for an LRT system as indicated below. On the other hand, MRT has great potential for its capacity with more than 20,000 persons.

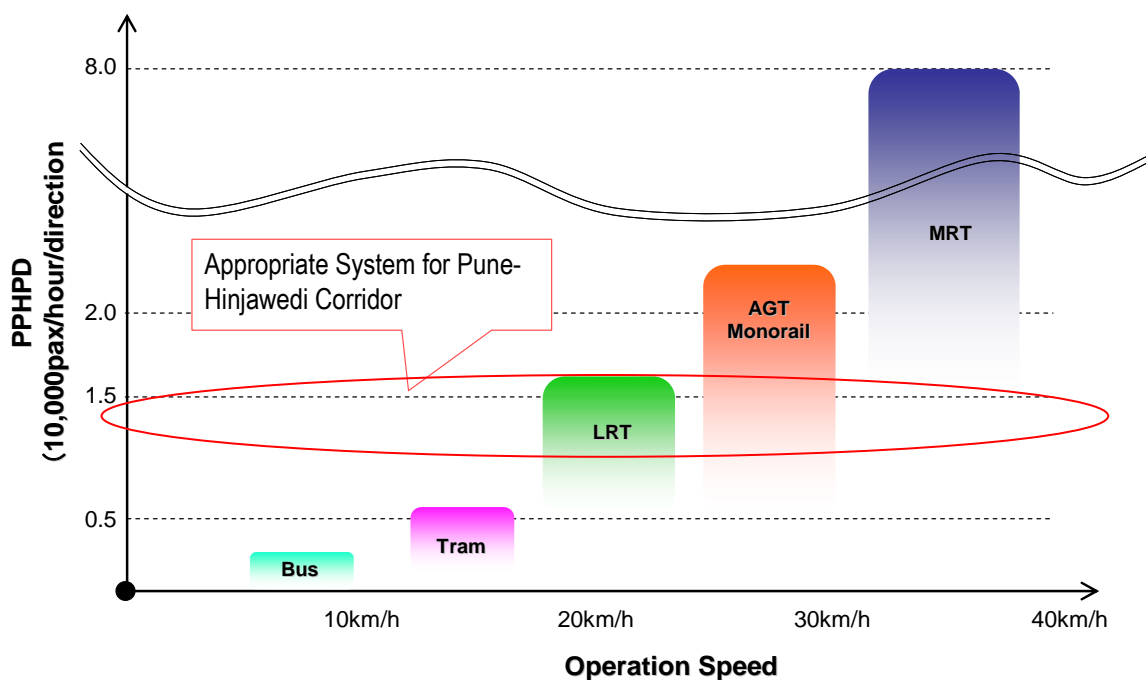

**Figure 5.5.1 Applicable System and Passenger Demand**

Source: JICA study Team

**<Corridor Alignment>**

The alignment has been set under the basic policy that an alignment basically passes through public land space along a corridor as mentioned in Chapter 5.1.1. Land acquisition for private land is one of the biggest issues in any county when a transport system is constructed.

In terms of flexibility of alignment setting, the LRT system has a big advantage in comparison with the MRT system. Minimum radius curvature of LRT is 20 meters, while MRT is 200 meters in general. This feature can largely contribute to the reduction of land acquisition area.

The next figure indicates our proposed alignment and minimum radius curvature with less than 200 meters. On the proposed corridor, it often falls below 200 meters, and minimal radius is 50 meters near Shivaji Nagar. Land acquisition along the entire route can be minimized by introducing an LRT System. The detail information on minimum radius is described in Figures 5.1.8 ~ 5.1.12.

If an MRT system had been selected for this corridor it would have required re-alignment and huge additional land acquisition due to the minimum radius of curvature. From the viewpoints of demand forecast, alignment and land acquisition, it is concluded that the optimum solution is to introduce a flexible system, an “LRT system”

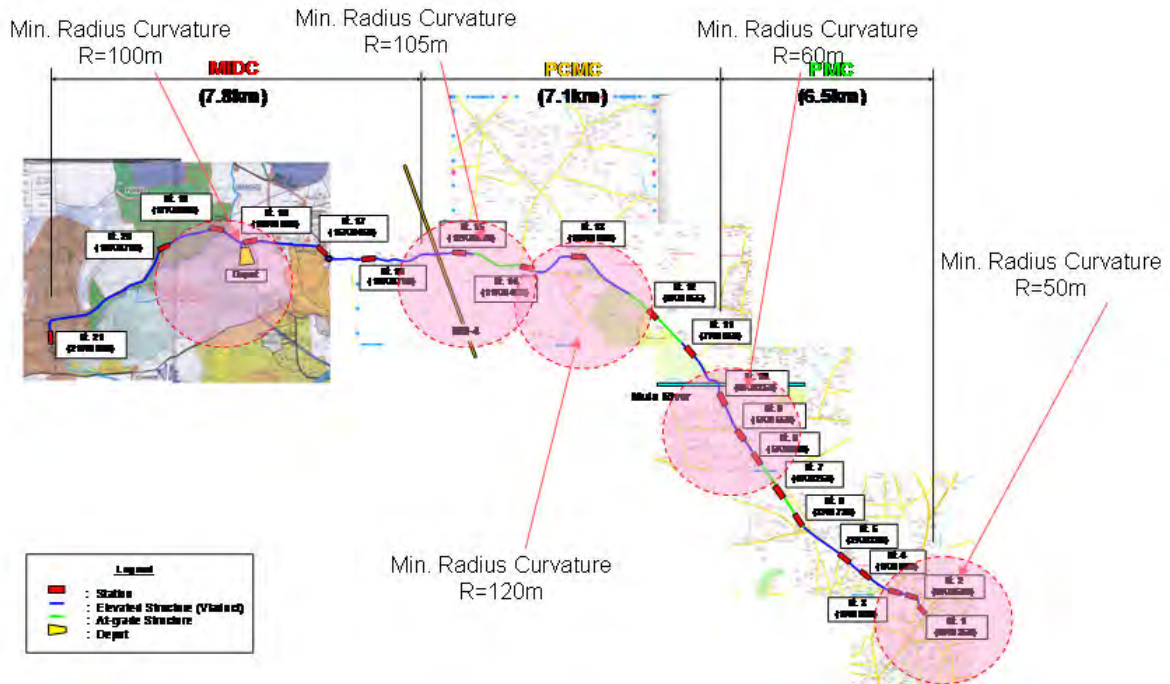

**Figure 5.5.2 Proposed Alignment and Min. Radius Curvature**

Source: JICA Study Team

## 2) Concept of LRT Systems

In terms of future passenger demand, it is most suitable to adopt an LRT (Tram) system as a mid-capacity transportation system. An LRT (Tram) system basically operates a vehicle by receiving electric power from an overhead catenary during running. However, an LRT (Tram) system with on-board electric power storage is proposed in this study. This is a battery-driven rail system which can operate continuously without any disruptions of electricity supply (hereinafter called a “Battery Tram System”).

The next figure describes basic concept of the Battery Tram system. The electric power can be recharged to an on-board rechargeable battery at the station during passenger’s boarding and alighting time through the station post (Battery and Charger). In addition, it is possible to utilize regenerative energy for recharging its battery. This energy is generated by braking behavior, and it can contribute much to the improvement of energy efficiency. By adopting a high efficiency and easy maintenance motor, the operation and maintenance cost can be reduced.

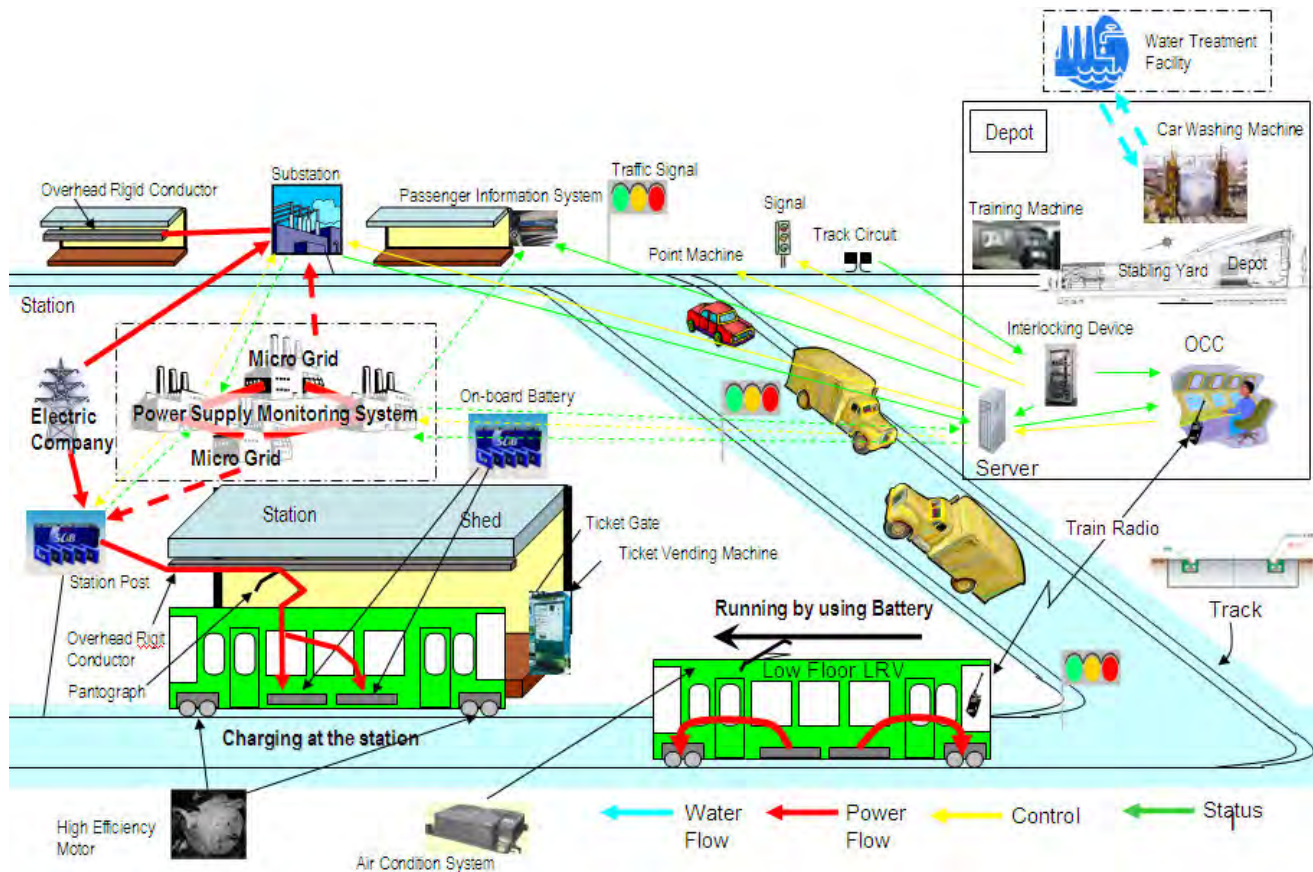

**Figure 5.5.3 Basic Concept of Battery Tram System**

Source: JICA Study Team

### 3) Advantages of Battery Tram System

A Battery Tram System equips a rechargeable battery on board as a power storage device and provides electrical power from its battery to on-board facilities and equipment for driving and control. It therefore does not need to receive electric power continuously from an overhead catenary line during running. The following advantages for a Battery Tram system are specified compared with conventional LRT system (power supply from overhead catenary) and MRT system (see Table 5.5.1). The system enables:

- ◆ To stably operate under any electric circumstances;
- ◆ To eliminate the construction, operation and maintenance cost of an overhead catenary;
- ◆ To preserve the city's landscape;
- ◆ To reduce energy consumption by regenerative energy use;
- ◆ To reduce the number of traction substations;
- ◆ To reduce the land space for substation facilities; and
- ◆ To minimize life-cycle cost (LCC).



Table 5.5.1 Comparison among Rail-based Transportation Systems

Systems	Items	Battery Tram System	Conventional LRT System	MRT System
	Image			
	Power Source	<b>On-board Battery</b> *Battery is recharged at station through overhead catenary	<b>Overhead Catenary</b>	<b>Overhead Catenary</b>
	Passenger's Demand	~ 15,000 PPHPD	~ 15,000 PPHPD	25,000 PPHPD ~
	Min. Curve Radius	20m Advantage to pass through road intersection * R=100m for mixed use sections	30m Advantage to pass through road intersection * R=100m for mixed use sections	200m
	Max. Gradient	70‰ Easy to pass through road grade separation	70‰ Easy to pass through road grade separation	30‰
	Energy Saving	<b>Excellent</b> with Regenerated Energy (Approximately 20% energy saving)	<b>Good</b>	<b>Good</b>
	Operation in Power Failure	<b>Operation Continue</b> With only on-board battery, a tram can transport passengers from origin to destination station (21.6km).	<b>Operation Suspended</b>	<b>Operation Suspended</b>

Source: JICA Study Team and General Information

Table 5.5.2 Comparison among Rail-based Transportation Systems (continued)

Items	Systems	Battery Tram System	Conventional LRT System	MRT System
Interval of Substations (Feeding Voltage)		Not Necessary	Interval: 3km (DC750V)	Interval: 5km (DC1,500V) Interval: over 20km (AC25,000V)
Necessary Land Area for Traction Substation		Not Necessary	Medium	Large
Overhead Catenary System for Running		Not Necessary	Necessary	Necessary (or Third-rail system)
Capital Cost Estimation (crore Rs./km)		E&M: 95.7 Civil: 86.2 Total: 181.9	E&M: 90.7 Civil: 86.2 Total: 176.9	Total: 196 (Mumbai Metro No.1) <sup>*1</sup> Total: 199 (Hyderabad Metro) <sup>*1</sup> Total: 125 (Delhi Airport Metro) <sup>*1</sup>
				Total: 243 (Pune Metro No.1) <sup>*2</sup> Total: 130 (Pune Metro No.2) <sup>*2</sup>
Operation & Maintenance Cost Estimation in average (crore Rs./km/year)		11.8	13.4	18.9 <sup>*2</sup>

Source: JICA Study Team and General Information

\*1: Calculated based on the report from Feedback Infrastructure Services Private Limited

\*2: Estimated based on "Detail Project Report on Pune Metro Project (2008)", Delhi Metro Rail Corporation

#### 4) Features of Battery Tram System

The features of a Battery Tram system are summarized as follows.

- ◆ It is possible to stably operate under any electric power situation.
- ◆ For the at-grade section, a “Resin” track structure”, in which the rail is fixed by resin is employed for the purpose of vibration suppression and noise reduction. The elevated section adopts a T-shape rail and slab structure with the rail tied directly to the slab.
- ◆ To operate a tram under an unstable electric power situation, it is proposed to employ a tram equipped with electric power storage. The vertical distance between the rail surface and the floor level is designed as a low floor with fewer steps in which barrier-free design is taken into consideration.
- ◆ At the station electric power storage facilities that mate with the on-board storage are furnished to recharge the on-board storage from the station side. To recharge the on-board storage, this system provides a rapid recharge function to complete the recharge in a short term. Meanwhile, the station post is recharged slowly by a power supply from a substation.
- ◆ At every station, the fare is collected automatically by automatic ticket gate and IC card/token to avoid congestion in the vehicle. An IC card/token is issued manually by staff at the station. The necessary information is recorded on IC chips embedded in plastic cards. This is possible because these IC chips are rewritable and reusable.
- ◆ To manage road traffic at the intersections of at-grade sections, LRT signals are established at the intersection. This implements an LRT Priority Signal measure to assure the punctuality and operates simultaneously with traffic signals subject to coordination with the road administrator.
- ◆ To realize efficient operation, the information on train operation and location are centralized at the Operation Control Center (OCC). The OCC monitors and manages this information.
- ◆ To increase the safety in the elevated section, an automatic block system, which allows only one train to enter a block section, is employed and it is also equipped Automatic Train Stop (ATS) function so that a train can be stopped automatically in the event of an emergency.
- ◆ As a backbone of the transmission network, optical fiber cable is to be installed along the entire route and it connects the OCC, stations, depot and other facilities. A radio system is installed to communicate between the ground facilities and the vehicles. At the stations, passenger information, public address and CCTV systems are furnished for the purpose of information provision and passenger safety.
- ◆ To remotely control and monitor the condition of necessary facilities, facility monitoring and control systems will be installed in the operation control center.
- ◆ A Maintenance Management Information System (MMIS) is implemented to manage assets and to schedule maintenance works.

### 5.5.2 Track System

#### 1) General

The track structure is basically different from a mass rapid transit system since LRT operates at the ground level and crosses the intersections using road space. Basic principles on rail selection and cant setting have been differentiated. The track system is summarized in the following table

**Table 5.5.3 Outline of Track System**

Items	At-grade Section	Elevated Section
Rail	Grooved Rail	T-shape Rail
Track Structure	Resin	Slab
Design Speed	Max. 80km/h	Max. 80km/h
Design Load	Axle Load 12t	Axle Load 12t
Radius of Curvature	Minimum 20m	Minimum 20m
Longitudinal Gradient	Max. 70‰	Max. 70‰
Cant	Not necessary*	Necessary
Limited Speed on Turnout	Passing through low speed	Passing through low speed

※ Cant in at-grade sections would affect road traffic due to the uneven surface, and may cause huge damage for tracks and then frequent maintenance works.

Source: JICA Study Team

#### 2) Features of Track System

##### (1) Rail

As shown in the following figure, a grooved rail is constructed for the at-grade section, however T-shape rail (equivalent to UIC54 or JIS 50kgN) is to be used for the elevated section.

Although T-shape rail is generally used for mass rapid transit system (MRT), a grooved rail has a groove on the head of a rail and it plays a role as a guardrail. It is not necessary to set wheel flange, therefore it's possible to construct itself in uniform surface between rail and pavement.

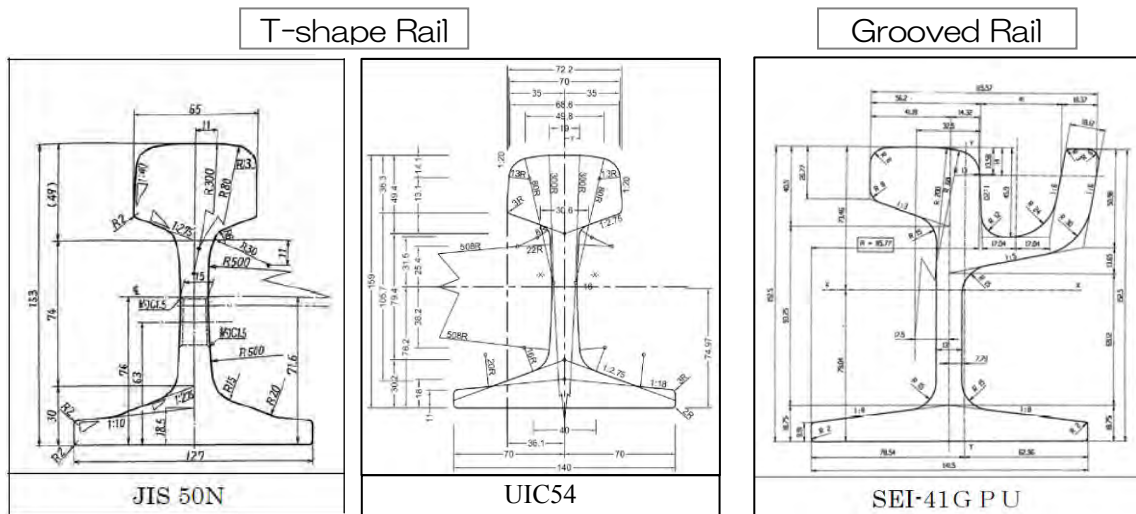

**Figure 5.5.4 Comparison of Rail Section**

Source: “Study on the Elementary Technology for LRT System”, Japan Transportation Planning Association

**(2) Track Structure**

Basically the ballast track is applied for the depot area and the slab track for the elevated section. For the at-grade section, a “Resin” Track is employed which is not jointed by bolts but fixed by a special resin. This can reduce vibration and noise; therefore, it is suitable for the at-grade section. As it is completely fixed with resin, it has advantages such as high sealing performance, and prevention of deterioration by water leakage. This Resin Track is widely used in Europe.

The comparison of track structure is shown in the following table.

**Table 5.5.4 Comparison of Track Structure**

Structure		Resin Track	Slab Track	Ballast Track
Section Implemented		At grade Section	Elevated Section	Depot
Structure	Roadbed	RC, PC Concrete	RC Concrete	Ballast
	Rail Joint	Fixed in Groove by Special Resin	Jointed with Slab by Bolts	Jointed with Sleeper by Bolts
	Pavement Surface	Concrete Asphalt Concrete Block Lawn	Asphalt Concrete Block Lawn	Concrete Asphalt Concrete
Function & Performance	Vibration	Small	Moderate	Moderate
	Track Irregularity	None	None	Often
	Rail Wear	Little	Corrugations occur	Little
	Deflection Measure	Pat+Special Resin	Hard resin under a rail	Ballast
	Water Leakage	Water Proofed by Special Resin	Prevented by Resin	High Drainage Performance
	Checking (Inner Structure)	Not necessary for Inner Checking	Impossible to check inside such as bolts due to pavement	Necessary to check rail fasteners
	Rail Replacement	Possible to replace a rail without pavement removal	Necessary to pave again after pavement removal	Possible to replace a rail without pavement removal
	Electric Corrosion	Not necessary	No countermeasure	No countermeasure
Cost	Construction	Moderate	Moderate	Low
	O&M	Low	Moderate	High

Source: “Study on the Elementary Technology for LRT System”, Japan Transportation Planning Association

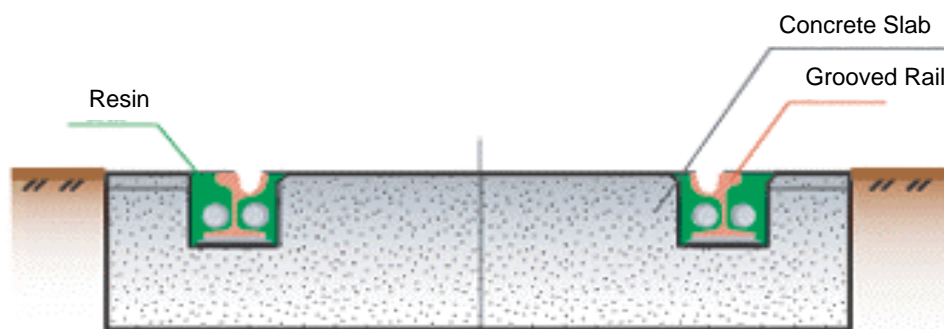

**Figure 5.5.5 Cross Section of Resin Track (Reference)**

Source: “Study on the Elementary Technology for LRT System” , Japan Transportation Planning Association

### 5.5.3 Rolling Stock System

#### 1) General

Rolling stock must function to stably operate under any electric power situation and to ensure passenger's safety by reducing the difference in height between the vehicle and the ground

#### 2) Characteristics of Rolling Stock

It equips an electric power storage system (battery<sup>\*1</sup>) on board, therefore it can be operating stably in case of unstable or blackout situation. The recharging of the on-board battery can be done during boarding and alighting at the station or the on-board battery can be recharged through a Station Post (Battery Charger) and additionally regenerative energy generated by braking motion. In order to reduce the barriers for passengers, the tram is designed as a low-floor system.

#### 3) Basic Data on Rolling Stock

Basic performance data and image of rolling stock are shown in the following table and figure.

Considering a passenger friendly and convenient system, LRV is designed as 100% low-floor vehicle.

**Table 5.5.5 Basic Performance of Rolling Stock**

Items	Details	Remarks
Basic Train Set	2 cars	3 modules per 1 car × 2cars
Passenger Capacity	Approximately 460 persons	Passenger Capacity = Seating + Standing Capacity Approx. 690 persons under congestion rate of 150%
Gauge	1,435mm	Standard Gauge
Minimum Radius of Curvature	20.0m	
Maximum Gradient	70‰	
Maximum Speed	80km/h	
Maximum Acceleration	4.0km/h/s	
Deceleration	5.5km/h/s (Normal) 6.0km/h/s (Emergency)	Track Brake for Emergency
Electrical Power Supply	DC 600V	Battery Driven (Only recharge at the station)
Brakes	Regenerative Brake and Mechanical Brake	From the result of an energy consumption simulation, energy saving by regenerative braking is assumed to be an approximately 20% reduction.
Train Protection System	Automatic Train Stop (ATS) Dead-man's Device	
Train Radio	Equipped	
Operating Condition for Emergency	Towed operation by Coupler	

Source: JICA Study Team

**Table 5.5.6 Basic Specification on Rolling Stock**

Items	Details
LRV	100% Low-floor Vehicle
Width of LRV	2,650mm
Length of LRV	60m (30m carx2 cars)
Other Facilities	Master Controller, Speed Meter, Radio Facility, Monitors, Train Destination Indicator, Onboard Information Board, Broadcasting Equipment, Air Conditioning, Signal Lamp (Front, Back) etc.

Source: JICA Study Team

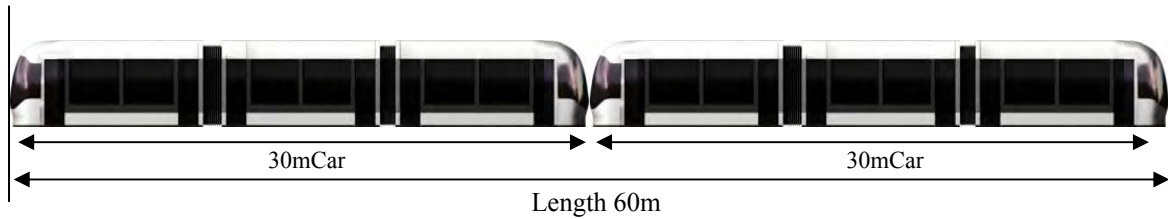

**Figure 5.5.6 Image of Rolling Stock**

Source: JICA Study Team

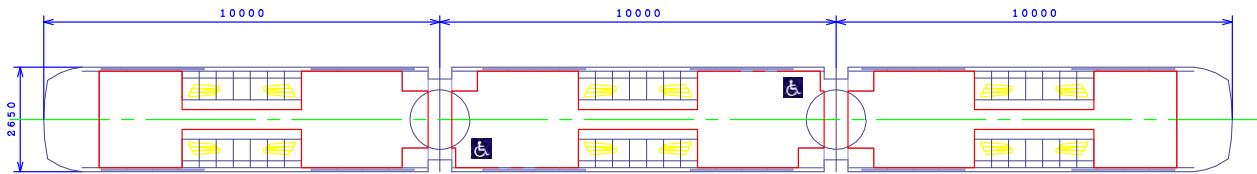

**Figure 5.5.7 Image of Seat Placement (30m Module)**

Source: JICA Study Team

**4) Clearance Gauge for Rolling Stock**

In general, the clearance gauge has not been set for LRT systems in Europe. From the safety viewpoint, it however, could be set at 40cm away from both sides of the rolling stock. If any structural objects exist in the median such as poles, an additional 40cm between the vehicle and the object should be set.

The height of the vehicle is approximately 3,800mm with the pantograph retracted. The overhead catenary which is installed only at the station to recharge the on-board battery, is temporarily set at a height of 5,000mm from ground level.

Basic concepts of the cross sections are shown in the following figure.

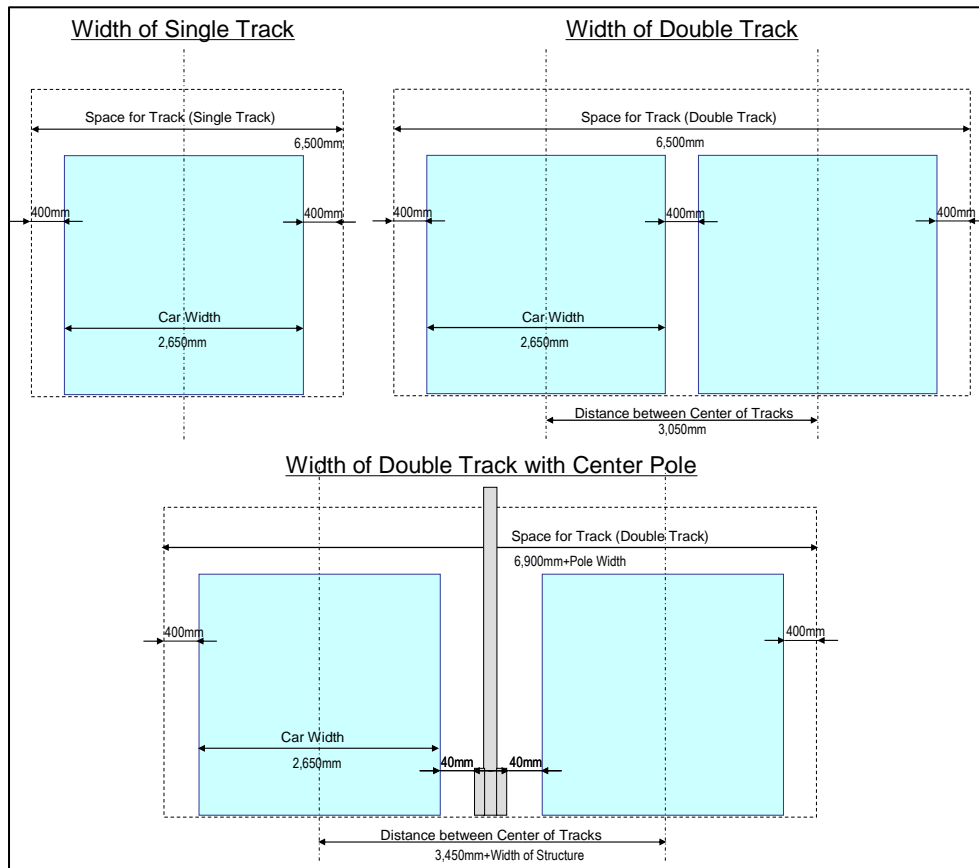

**Figure 5.5.8 Basic Concept of Cross Section**

Source: “Study on the Elementary Technology for LRT System”, Japan Transportation Planning Association

### 5.5.4 Signaling System

#### 1) General

Signaling provides for highly reliable and secured operation of the Tram system. This study proposes a mixed structure with at-grade and elevated sections, therefore the Signaling facilities are optimized depending on the situation and location. The following table summarizes the Signaling system for at-grade and elevated sections.

**Table 5.5.7 Outline of Signaling System**

Items	At-Grade Section	Elevated Section
Train Detection System	Track Circuit Transmitter	
Train Protection System	Visual Check by Driver	Automatic Block Automatic Train Stop (ATS)
Signal Light System	Two Aspect Signal Light	Color Light Signal (Three Aspects)
Route Control System	Route selection by centralized control from OCC or portable remote controller by driver	
Interlocking System	—	Relay Interlocking Device

Source: JICA Study Team



## **2) Systems Configuration**

### **(1) Train Detection System**

The Train Detection System enables collection of the information on the position of trams on the line.

In the elevated section as well as at the location where turnouts are located, a train is detected by a track circuit. By using tram location information, the OCC controller can monitor the locations of all trams in operation, and control the turnout remotely from OCC. In the elevated section, an Automatic Block System and Automatic Train Stop System can assure the safety and operation speed using the tram location information.

### **(2) Train Protection System**

Train Protection System ensures safe tram operation and ensures the safe distance between trams. Train protection is assured by the driver's visual confirmation for at-grade sections as a tram operates at relatively slow speed. On the other hand, an automatic block signal system is installed in the elevated section which allows only one tram in each block section.

With an Automatic Train Stop system, a tram will be stopped automatically by an emergency brake if a driver misses a stop sign at a block signal, etc.

### **(3) Signal Light System**

An indication of signal lights is designed in 3 aspects; Proceed, Slowdown and Stop.

The tram location information is transmitted to the road traffic signals for appropriate traffic control i.e. extension of green signal duration or reduction of red signal duration.

### **(4) Route Control System**

Sensors of the remote controller for turnouts are installed along the track. A driver operates the portable remote controller for switching the turnout. Inside the depot area and lead-in track, the turnouts can be controlled remotely by the OCC controller.

### **(5) Interlocking System**

By using the train detection information, the Interlocking system basically detects vacancies at points and track sections, and controls switching or locking of turnouts and control signals, but it is not limited to the abovementioned functions. It is installed at the station where the turnout is located and the lead-in-track to the depot area.

### **(6) Operation Control Center (OCC)**

The Operation Control Center is established to manage and control the LRT system. An Operation Management System which has the following functions is installed in the OCC.

## ① Train Schedule Management

There are two types of train diagrams; one is a scheduled diagram, and the other is the actual diagram which is drawn based on actual train operation. Both diagrams can be indicated independently or integrally on the same display. It helps the OCC controller to understand any delay in tram operation well.

## ② Train Location Indicator

Train location information collected by the train detection system can be shown on the route map. The train number is also shown on the same map.

## ③ Operation Monitoring System

The Operation Monitoring System continuously monitors the scheduled and actual diagrams. If a delay from the scheduled diagram exceeds a certain time, the system automatically raises an alarm on the display.

### **Traffic Signals at Intersections**

During operation in the at-grade section, a tram is running in the road space. It is necessary to take a measure to ensure the tram's punctuality in the mixed road space where trams, cars, motorcycles, buses, rickshaws and pedestrians exist.

If a tram is approaching the intersection, the punctuality of tram operation will be assured by reducing the red signal or extending the green signal. In Pune Municipal Corporation (PMC), a BRT priority signal has been installed on the BRT route as shown in the picture below. Such system could be beneficial to introduce LRT Priority Signals for the LRT system. It can give priority to a tram when a tram approaches the intersection. At the intersections without traffic signals, it is proposed to install traffic signals as well as the LRT signal.



**Figure 5.5.9 BRT Priority Signals along BRT Route in PMC**

Source: JICA Study Team

## 5.5.5 Telecommunications System

### 1) General

The telecommunications system is significant to exchange information supporting the safe and secure operation. For the purpose of comfortable usage, this system also provides passengers with several items of information such as train approaching, departing time, delay information.

**Table 5.5.8 Outline of Telecommunications System**

Functions	Facilities	Remarks
Backbone Transmission Network	Optical Fiber Cable Broadband Radio	<ul style="list-style-type: none"> <li>Constructed along the main line</li> <li>Connected between OCC and each base</li> </ul>
Radio System	Central Radio Server	<ul style="list-style-type: none"> <li>Including Recording Function</li> </ul>
	Radio Base Station	
	Train Radio	
	Handy Radio	
Public Address System	Public Address (PA)	
	Information Board	<ul style="list-style-type: none"> <li>Sign for Train Approaching</li> </ul>
Telephone System	Dedicated Telephone	<ul style="list-style-type: none"> <li>Dedicated Line within the company</li> </ul>
Clock System	Clock	<ul style="list-style-type: none"> <li>OCC, Stations, and LRVs</li> </ul>
Surveillance Camera	CCTV	<ul style="list-style-type: none"> <li>Each Station, Major Intersections, Bridges, Depot</li> <li>Video data is transmitted to OCC through optical fiber cable.</li> </ul>
Facility Monitoring and Control System	SCADA	<ul style="list-style-type: none"> <li>Remote facility control, Information collection of equipment failures</li> </ul>
Maintenance Management Information System	MMIS	

Source: JICA Study Team

### 2) System Configurations

#### (1) Backbone Transmission Network

The Backbone Transmission Network transmits the train location, video and passenger information among the OCC, depot and stations etc.

- It makes it possible to communicate with the OCC, Depot and Stations and other facilities.
- It forms a fault-resistant structure with a dual cable network in preparation for cable breaks and equipment failure.
- The network cable is accommodated between the tracks in the at-grade section and inside the trackside cable trough in the elevated section.

Other than optic fiber cable, the broadband radio system as a backbone transmission network will be considered.

**(2) Radio System**

The Radio System makes it possible to communicate among the OCC controller, drivers, and maintenance staff etc. by voice and data communication. It covers all trackside and inside buildings as a call-enabled area.

Furthermore, it can issue a warning at the same time from the OCC controller to drivers and maintenance staff and record a call log between the OCC controller and drivers in the OCC recording device.

**(3) Public Address System**

By using the train location information collected from the track circuit, the Public Address System announces the train approaching to the stations through the information board (text data) and by speaker (voice data).

In case of operational problems due to accidents, its system can send text and voice information from the OCC controller to the passengers through the broadcasting equipment.

**(4) Clock System**

The Clock System is installed to operate and manage the LRT system with unified time. A master clock could be placed in the OCC, and servant clocks in stations, the depot and on board. Servant clocks will be synchronized with the master clock through the backbone transmission network. This helps to control the entire LRT system under the same time system.

**(5) Surveillance Camera System (CCTV)**

Surveillance cameras will be installed at platforms and ticket booths to monitor suspicious individuals and ensure passenger security. The information retrieved from the cameras is transmitted to the OCC, and the OCC controller can monitor these video pictures on the monitor.

**(6) Facility Monitoring and Control System (SCADA)**

The Facility Monitoring and Control System can collect the failure information on facilities equipped in substations, stations, wayside, the OCC and the depot, and issue a warning on the OCC monitor and output an alarm. This failure information will be stored in the system as a history.

**(7) Maintenance Management Information System (MMIS)**

The MMIS functions in maintenance planning and asset management to keep the LRT system in the best condition without any negative impacts to passenger transportation.

**① Maintenance Plan**

This produces maintenance and repair schedules for each facility in consideration of the condition of the inspection cycle/facilities and hours worked.

② Asset Management

This system manages the numbered facilities and keeps a history (purchase, failure, repair etc.). In addition, it examines the life-cycle cost of each facility by calculating its asset value and makes a list of facilities with a short life span.

## 5.5.6 Substation System

### 1) General

This chapter mentions the power supply system for the Battery Tram system without overhead wires.

It consists of a facility to receive the power from the electric power company, a substation facility to convert the received voltage to an electric voltage for the purpose of railway system usage, and distribution facilities to distribute it to each facility at the station, along the wayside and other operation-related facilities. Since the battery tram does not need an overhead catenary or a traction substation for this system, the land space for a traction substation could be eliminated.

### 2) System Configurations

#### (1) BSS (Bulk Substation)

The BSS receives the electric power from MSEDCL (Maharashtra State Electricity Distribution Co., Ltd.) in Pune. In order to supply power to every station and substation along the line, a Bulk Substation is constructed at each end point of the route. Receiving voltage is 22kV each and converted to 6.6kV. In a normal case, the area of electric supply extends to a Switching Post (mentioned in the following (2) SW Post).

To establish redundancy, it is required to possess the ability to supply electric power from one BSS to the entire line in case of emergency.

#### (2) SW Post (Switching Post)

In order to establish redundancy, a Switching Post (SW Post) is constructed in the middle of the distribution line in case multiple BSS have been constructed. A circuit breaker in the SW post is normally open. If failures happen at one of two BSSs and it disables the power supply, the circuit breaker of the SW Post will be closed so that the other healthy BSS can supply the electric power. This function increases the reliability and redundancy of the system.

#### (3) Station Post

A Station Post (located at each station) converts the distributed electricity of 6.6kV from the BSS to AC voltage, supplies the electricity to the load of the station such as lighting and elevators etc. In addition, the battery post will be equipped in order to realize rapid charge of the on-board battery when the train stops at the station. A PCS (Power Condition System) is equipped at the primary side

of the battery and converts to DC600V, which is the charging voltage of the battery. DC circuit breakers are equipped on both sides of the battery, and charging/discharging could be switched by DC circuit breakers. The following figure describes a concept of switching charge/discharge by DC circuit breaker.

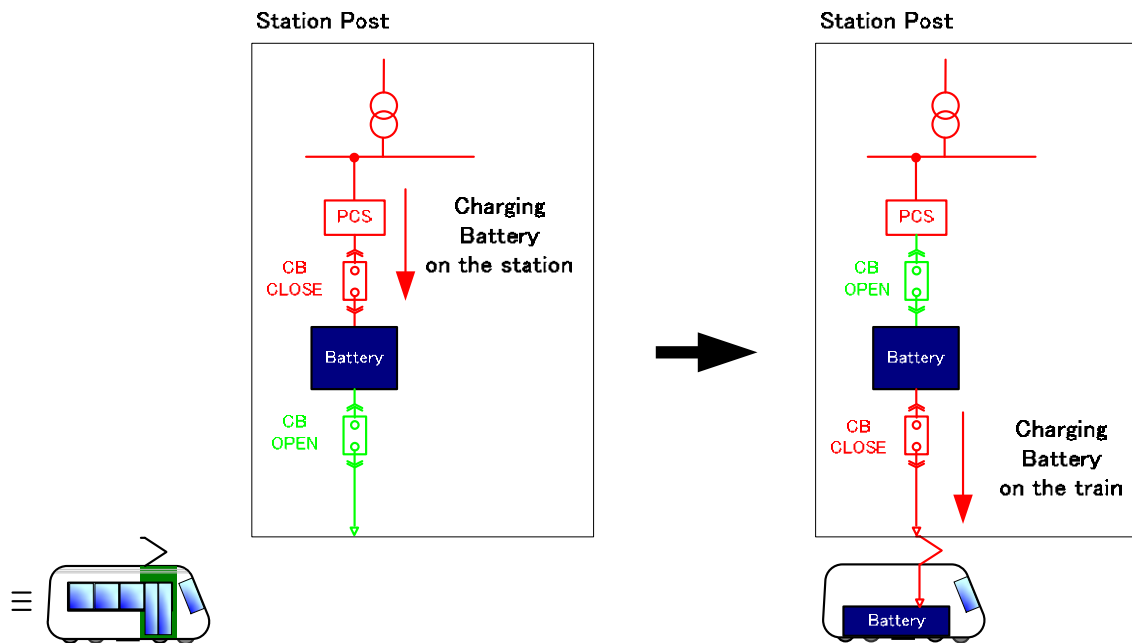

**Figure 5.5.10 Switching scheme of charge/discharge of the battery**

Source: JICA Study Team

#### (4) Depot SS (Substation)

The Depot SS is a substation for supplying the electric power to the Depot. It supplies the electric power to equipment and facilities in the depot as well as makes it possible to recharge LRVs which are parked in the depot.

#### (5) SCADA (Supervisory Control And Data Acquisition)

SCADA is equipped at the Operational Control Center (OCC). It plays roles to; (a) control each piece of equipment at the station post and substation (b) supervise the states of each post.

### 5.5.7 Automatic Fare Collection System

#### 1) General

Fare is a significant financial source to operate a tram adequately. There are several types of fare collection systems. The system should avoid disruption at the station and/or in the train, and ensure the expandability with other public transportation systems. In this study, the contactless IC card/token is adopted as the ticket type, and the tickets will be sold at ticket booths near the station. The following table summarizes the fare collection system. The details are indicated in Annex 2.

**Table 5.5.9 Outline of Automatic Fare Collection System**

Methods	Detail Method	Remarks
Type of Fare Collection	Ticket Gate	
Type of Ticket	Contactless IC Token Contactless IC Card	IC Card for Train Pass
Standard of IC Card	Felica	Suitable to process huge amount of passengers
Others	Possible system to use commonly among BRT, Bus, MRT and LRT in the future	Need to follow the movement of Indian Common Mobility Card

Source: JICA Study Team

## 2) Features of Ticketing System

### (1) Ticketing Type

There are some issues for fare collection method such as ticket issuing and fare collection at every ride. However, they can be solved with a “Pre-paid” and “Post-paid” card system. This card system is suitable for this kind of transportation system because it does not need to issue the ticket every time at the station and it is re-writable and re-usable.

The advantages of an IC card system are:

- i) to be compatible with different operators and different fare systems by writing several pieces of information on the card such as boarding station, boarding time etc.
- ii) to promote the efficiency of train operation by reducing fare collection by an employee on board
- iii) to ensure the reliable fare collection among other operators; and
- iv) to understand the passenger trends.

**Table 5.5.10 Advantage of IC Card**

	Advantage of IC Card	Advantage of Commoditized Ticket
User's Benefit	<ul style="list-style-type: none"> <li>• Possible to get on a train smoothly</li> <li>• Cashless System</li> <li>• Reduce time for fare adjustment</li> <li>• No need to take out from pass case</li> <li>• congestion relief at station/ticket gate</li> </ul>	<ul style="list-style-type: none"> <li>• Possible to use one card for several transport systems</li> <li>• Seamless transfer to other transport modes</li> <li>• Improvement of convenience by integration with other functions such as goods purchase</li> </ul>
Operator's Benefit	<ul style="list-style-type: none"> <li>• Alleviation of Traffic Jams by reducing the stop time at the station</li> <li>• Reduction of Maintenance Cost</li> <li>• Anti-counterfeit</li> <li>• Customer retention by unification with credit card</li> <li>• Downsizing of station and congestion relief at station/ticket gate</li> </ul>	<ul style="list-style-type: none"> <li>• Possible to set flexible fare structure</li> <li>• Possible to take actions for promotion of utilization</li> </ul>
Social Benefit	<ul style="list-style-type: none"> <li>• Promotion of IC Card Recycling</li> <li>• Alleviation of Traffic Jams by reducing the stop time at the station</li> <li>• Downsizing of station and congestion relief at station/ticket gate</li> </ul>	

Source: “Study on the Elementary Technology for LRT System”, Japan Transportation Planning Association

In India, the IC Card system has been employed for Metro systems. It is mentioned that the proposed Pune Metro system plans to adopt the contactless IC card system. Consequently, this study decided to employ a contactless IC card system for several passes and IC token for single trips in order to facilitate share usage with other systems.

## (2) Standard of IC Card

One of the biggest railway operators in Japan, the East Japan Railway Company, has employed the contactless IC card system called “Suica”. This is a “Felica” system which was developed by Sony. As shown in the following table, the IC Card system is standardized throughout the world by the International Organization for Standardization (ISO).

**Table 5.5.11 Major Standards for ISO/IEC14443 (Contactless IC Card)**

Standard	Proposed Company	CPU	Processing Speed	Examples
Type A	Philips Infion	N/A	106kbps~	Japan (Fukushima)「IC Card」 Japan 「IC Telephone Card」 Card for entering or leaving a building etc.
Type B	Motorola	Built-in	106kbps~	Japan 「Resident Registration Card」 etc.
Type C (FeliCa)	Sony	Built-in	211kbps~	Japan (JR East)「Suica」 Japan (JR West)「ICOCA」 Hong Kong「Octopus」 Singapore「ez-link card」 India (Delhi)「Travel Card」 Thailand (Bangkok)「Metro Card」 Electronic Money「Edy」 etc.

Source: “Study on the Elementary Technology for LRT System”, Japan Transportation Planning Association

This study decided to employ Type C (Felica). It is important for a transportation card to assure the processing ability and speed.

On the other hand, the “Common Mobility Card” system has been considered in India for the purpose of having a unique transportation card system. It should be taken into consideration to realize shared usage.

## (3) Ticket Gate

The automatic gate, which is installed at the ticket gate or the ticket collection gate, is a machine that reads or collects tickets on behalf of the station staff. The types of automatic gates are for both entrance and exit. At the entrance, the gates read the necessary information from the IC card and write the entrance record on it. At the exit gate, the gate again reads the card and the fare is adjusted and confirmed based on the entrance record. It is suitable to employ “Flap type” gates as the simplest gate from the point of processing speed.



## 5.6 Possibility to Develop Station and Surrounding Area

### 5.6.1 The study about the scale of facilities

TOD (Transit Oriented Development) is an urban development method to create a mixed-use residential and commercial area around the node of public transportation, which will maximize access to public transport. This will provide easy access from residences to offices/schools/ shops by Public Transportation. TOD will also encourage transit ridership, and it will result in stable ridership and will be beneficial for the operator of the public transportation.

To develop mixed-use (commercial and residential) facilities around the station along with development of public transportation will allow the public transportation operator to increase income from non-rail businesses (e.g. real estate, shops, hotels, etc.).

Currently St 2 Shivaji Nagar Station area has a function as a transfer station/point to long distance buses, city buses, railways, taxis and rickshaws. Future development of MRT and BRT will make some stations transfer stations, such as JM Temple Area, Pune University Area, State Hospital Area, and Wakad Chawk Area.

Location of these LRT stations should be close to the BRT/MRT stations and easy transit access should be secured for passengers. Development of these transit stations is expected to encourage people's use of LRT, and also to attract private investors to this LRT business.

Potential and possibility to develop the following stations are discussed in this chapter.

- Station-2 Shivaji Nagar Station :  
Redevelopment plan to connect LRT Station with Shivaji Nagar Bus Terminal, Shivaji Nagar Station, Pune Metro Station
- Station-12 State Hospital Station :  
Proposal to connect BRT station, City Bus Terminal and LRT Station to the State Hospital
- Station-18 LRT Depot (RGIP Phase 4) :  
Possibility to develop the Depot site for commercial use.
- Station-15 Wakad Chawk2 :  
Possibility to develop as transfer station to BRT and long-distance buses on NH-4.

### 5.6.2 Station-2 Shivaji Nagar Station

#### (1) Current situation of Shivaji Nagar Station Area

St-2 Shivaji Nagar Station is proposed to be located near the junction of University Road and Shivaji Road, approximately 150m south of the Shivaji Nagar Bus Terminal. Shivaji Nagar Station of the Indian Railway is also located near the Bus Terminal, 150m from the Bus Terminal. As shown in Figure 5.6.1, this area contains hotels, restaurants, cafés, shops, and schools and is

crowded with passengers, students, auto-rickshaws, taxis, motorcycles and private cars in general. A new station of PUNE METRO Line 1 is planned to be constructed under the Bus Terminal, and is expected to cause more traffic in this area.

In order to mitigate the traffic congestion in this area, PMC proposed to construct a skywalk from the Bus Terminal towards Mandai along the Shivaji Road, but the plan was canceled because of the insufficient user rate expected.

Shivaji Nagar Bus Terminal is one of the four Bus Terminals for long distance buses in PUNE. This Bus Terminal owns 153 buses, and the number of buses that comes to / goes from Shivaji Nagar Bus Terminal per day is between 800 and 1,100. This number of buses and frequency of Bus arrivals/departures are far beyond the expected number when the terminal was built in 1968. According to the Maharashtra State Road Transport Corporation (MSRTC), owner of this Bus Terminal, this Bus Terminal obviously must be expanded, but it is difficult to find available area around the existing terminal.

In order to secure smooth bus operations, MSRTC desires to improve the traffic flow of the area by limiting the encroachment by small shops, taxis, and rickshaws around the Bus Terminal.

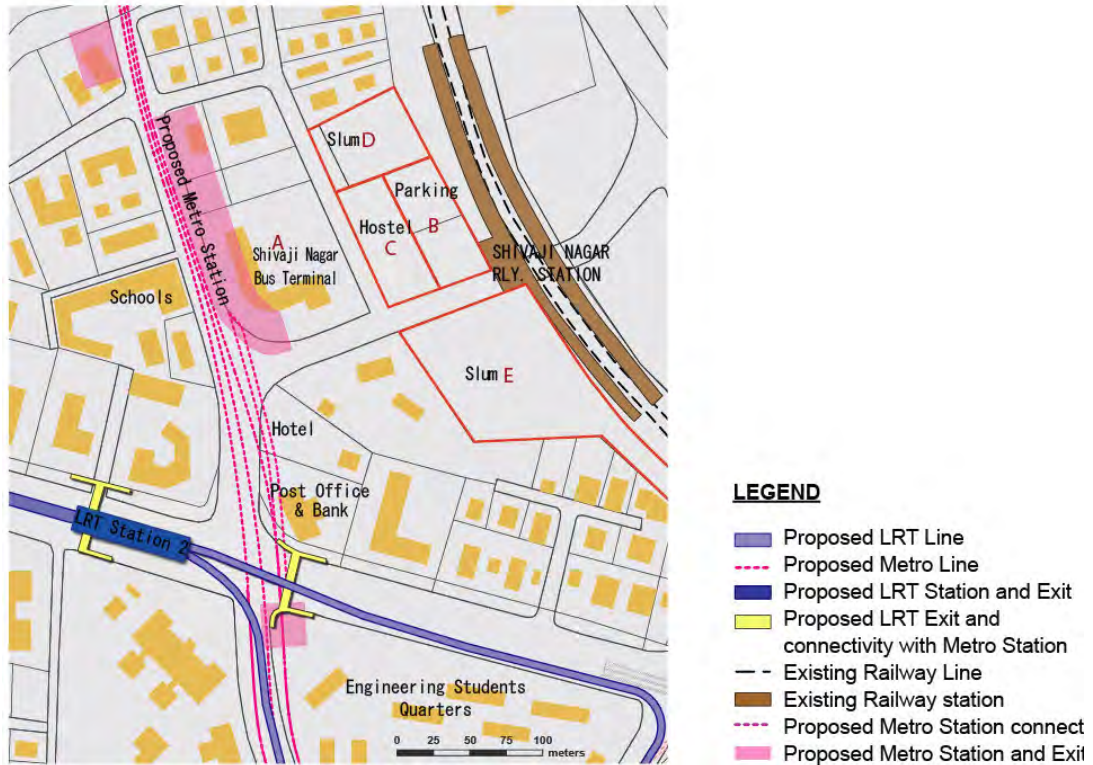

Source: Base map : PMC Land Use Development Plan, PMC Web.  
Proposed Metro Line and Station: General Alignment Drawing of Pune Metro 2008, DMRC  
Proposed LRT Line & Station : JICA study team

**Figure 5.6.1 Proposed location of LRT Shivaji Nagar Station**

Table 5.6.1 shows the summary of the current situation of Shivaji Nagar Bus Terminal and Railway Station area.

**Table 5.6.1 LRT Shivaji Nagar Station Area: Target sites for redevelopment**

	Land Ownership	Land Use	Area	F.S.I	Plot
Shivaji Nagar Bus Terminal	MSRTC	Bus Terminal, Bus Depot, Drivers Accommodation, etc.	10,600m <sup>2</sup>	2.0	A
Shivaji Nagar Station Area	Indian Railway (Possibility to be partially purchased by PMC )	Plaza and Car Parking Spaces (bikes and cars)	3,100 m <sup>2</sup>	2.0	B
		Hostel for family members of Indian Railway Staff	3,100 m <sup>2</sup>	2.0	C
		Slum	3,500 m <sup>2</sup>	2.0	D
Slum Area	Slum Improvement Corporation	Slum	11,500 m <sup>2</sup>	2.5	E

Source: Land Use Development Department, PMC

**A Shivaji Nagar Bus Terminal**

Constructed in 1968, as one of the four bus terminal for long-distance buses in Pune, it has been over-capacity since the 1990s.

On-site facilities: bus station, bus depot (including maintenance facilities), luggage delivery offices, bus company office, drivers accommodation, and bike parking.

This bus terminal owns 153 buses, but this site allows to park only 78 buses and about 20 buses are parked at renting space in other bus terminal.

MSRTC wishes to improve this situation around the bus terminal and the station, as this area is significantly congested with pedestrians, bikes, city buses, taxis, and cars.

Site owner: MSRTC (Maharashtra State Road Transport Corporation)

Site area : 10,600 m<sup>2</sup>  
FSI : 2.0



Bus terminal entrance from the station's side



Bus stops (14 bays). Due to minimum space in between the buses, it's hard to get on/off the buses.



Bus waiting area

There are only 14 bus stops. Due to the insufficient space for waiting, some buses wait on the surrounding roads.

Number of buses that depart and arrive: 814 buses / day (September 2012).  
During peak time: 1,100 / day.



**F Bus Terminal of School in the West Area**

3 schools in one site proximity to the Bus Terminal, causing even more traffic jam during school start/finish time.



Students gathering in front the school's entrance



Kids walking on the way to or from school.

**C Hostel for family members of Indian Railways' Employees**

A hostel for the children of Indian railway's employees (28 people currently staying)

Site owner : Indian Railway  
Site area : 3,200 m<sup>2</sup>  
FSI : 2.0



**E Slum Area**

Site management: (Slum Improvement Corporation)  
Site area : 11,500 m<sup>2</sup> FSI : 2.5



Front side



back side

The condition is good at the front side but there's a significant gap inside the area.

**D Slum inside the Indian Railways Area**

With a slum improvement project in the past, the living environment is pretty good.

Site owner : Indian Railway  
Site area : 3,500 m<sup>2</sup>  
FSI : 2.0

**B In front of Indian Railway Shivaji Nagar Station**

**Parking Area in front of the station**

Parking fees : car 10Rp./4h, bike 5 Rp./6h

Capacity : 25 cars, 350 bikes

Number of users per day: Around 60 cars, 400 bikes



Bike parking space : Fully occupied

**Open Space in front of the station**

Even though this station is only for local trains, the passengers are many, causing congestion of pick up cars, city buses, taxis, rickshaws, stalls, etc.

Site owner : Indian Railway  
Site area : 3,200 m<sup>2</sup>  
FSI : 2.0



Shivaji Nagar Station & Rickshaw Stand



City Bus Stop in front of the station

Figure 5.6.2 Station2 Shivaji Nagar Station Surrounding Condition

Source: Boundary of the land from Land Use Development Plan PMC, Proposed Metro Line and Station from General Alignment Drawing of Pune Metro 2008, DMRC, Information of Shivaji Nagar Bus Terminal from Maharashtra State Road Transport Corporation, others from JICA Study Team

## (2) Study on possibility to redevelop around the Shivaji Nagar Station

With the proposed LRT station (St-2) and new station of Pune Metro under the Bus Terminal, this area will be an intermodal center for several public transportation modes. Because of this, this area has a high potential to be re-developed as a mixed use center with a TOD Concept, and redevelopment of this area is assumed to encourage development of the local economy.

In addition, integration with Railways, long-distance buses, city buses, taxis and rickshaws, and the new Pune Metro at this station will raise the value of this area, and is expected to increase the convenience of the LRT system and attract more passengers.

On the other hand, this intermodal center with mixed-use development will attract more taxis, rickshaws, and private vehicles, and integrated and comprehensive redevelopment of this area is required to improve the traffic circulation of this area as well as to encourage commercial development.

Accordingly, the possibility to re-develop this area was studied based on the following objectives;

- to improve traffic congestion of this area,
- to enhance passenger convenience as an intermodal center of public transportation,
- to encourage local economic activities by re-development based on the TOD concept.

The following three optional scenarios were studied and pros and cons. of these options were compared.

- Option 1 : Skywalk to connect LRT St 2 with the Bus Terminal and Metro Station, and redevelopment of the Bus Terminal are proposed.
- Option 2 : Skywalk to connect LRT St 2 with the Bus Terminal, Pune Metro Station, and Shivaji Nagar Station Plaza, and redevelopment of the Bus Terminal and Station Plaza are proposed.
- Option 3 : Skywalk to connect LRT St 2 with the Bus Terminal, Pune Metro Station, and Shivaji Nagar Station, and redevelopment of the Bus Terminal, Station Plaza and Slum area in front of the Station.

The following instructions given by PMC office are applied to this study.

### 1) F.S.I.

- Government owned land, and development for public use : F.S.I 2.0
- Redevelopment of Slum Area : F.S.I 2.5
- There is a discussion that F.S.I of the area within 500m from Metro Station is changed to 4.0. The case which is applied F.S.I 4.0 was also studied.

### 2) Exemption of floor area for FSI calculation

- Floor area for Public Car Parking can be exempted from the floor area calculation. (ceiling height should be between 2.4m to 2.8m.

- There is no rule for parking space for public buses at this moment. However, according to the discussion/advice from PMC, there is a possibility to establish an additional rule for exempting the public bus parking space. The bus parking area was exempted from the calculation.

### 3) Building Height Limitation

- According to the PMC office, the building height limitation for Shivaji Nagar Area is 100m.

**Table 5.6.2 Comparison of re-development scenario options of Shivaji Nagar Station Area**

		Option 1	Option 2	Option 3
Target Sites		A	A, B, C	A,B, C, D, E
Site Area		A: 10,600m <sup>2</sup>	A: 10,600m <sup>2</sup> B+C:6,200 m <sup>2</sup>	A: 10,600m <sup>2</sup> B+C+D:9,700 m <sup>2</sup> E: 11,500 m <sup>2</sup>
Limit of Total Floor Area	F.S.I.2.0 and F.S.I. 2.5	A: 21,200m <sup>2</sup>	A: 21,200m <sup>2</sup> B+C:12,400 m <sup>2</sup>	A: 21,200m <sup>2</sup> B+C+D:19,400 m <sup>2</sup> E: 28,800 m <sup>2</sup>
	F.S.I. 4.0	A: 42,400m <sup>2</sup>	A: 42,400m <sup>2</sup> B+C:24,800 m <sup>2</sup>	A: 42,400m <sup>2</sup> B+C+D:38,800 m <sup>2</sup> E: 46,000 m <sup>2</sup>
Development Contents	Use of Buildings	Bus Terminal Complex: Bus Terminal, Bus Depot, Metro Station, Waiting Space, MSRTC Office, Accommodations for Bus Drivers, Commercial & Office uses, etc.	Bus Terminal Complex:ditto Station Plaza: City Bus Stops, Taxi, Stands, Rickshaw Stands, etc. Indian Railway Complex: Public Parking Spaces, Hospital for family members of Indian Railway Staff, Staff Accommodations, Public Service Facilities (post office, clinic, etc.) Commercial & Office Use.	Bus Terminal Complex:ditto Station Plaza: ditto Indian Railway Complex:ditto Slum Redevelopment Building: Public Parking Spaces, Commercial and Residential uses.
	Building Capacity (FSI 2.0)	Bus Terminal Complex:10F	Bus Terminal Complex:10F Indian Rail Complex : 11F	Bus Terminal Complex:10F Indian Rail Complex : 11F Slum Redevelopment. Building:13F
	Leasable Area	10,000m <sup>2</sup>	16,000m <sup>2</sup>	34,000m <sup>2</sup>
	Building Capacity (FSI 4.0)	Bus Terminal Complex:16F	Bus Terminal Complex:16F Indian Rail Complex : 22F	Bus Terminal Complex:16F Indian Rail Complex : 22F Slum Redevelopment. Building:22F
Leasable Area	26,000m <sup>2</sup>	39,000m <sup>2</sup>	71,000m <sup>2</sup>	
Public Parking Spaces	Nil	80 Cars, 400 Bikes	200 Cars, 700 Bikes	

Source: JICA Study Team

Option 1

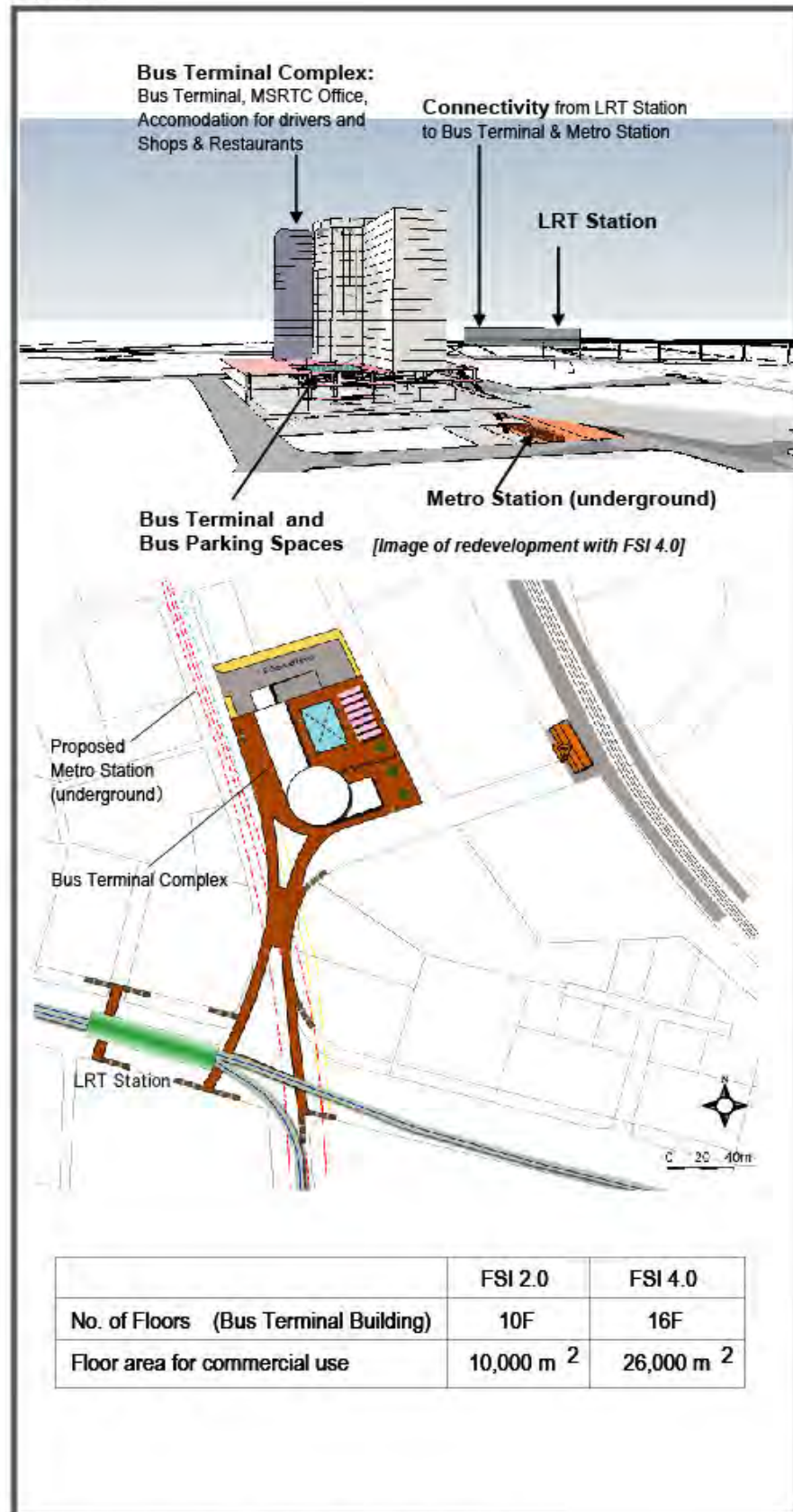

Option 2

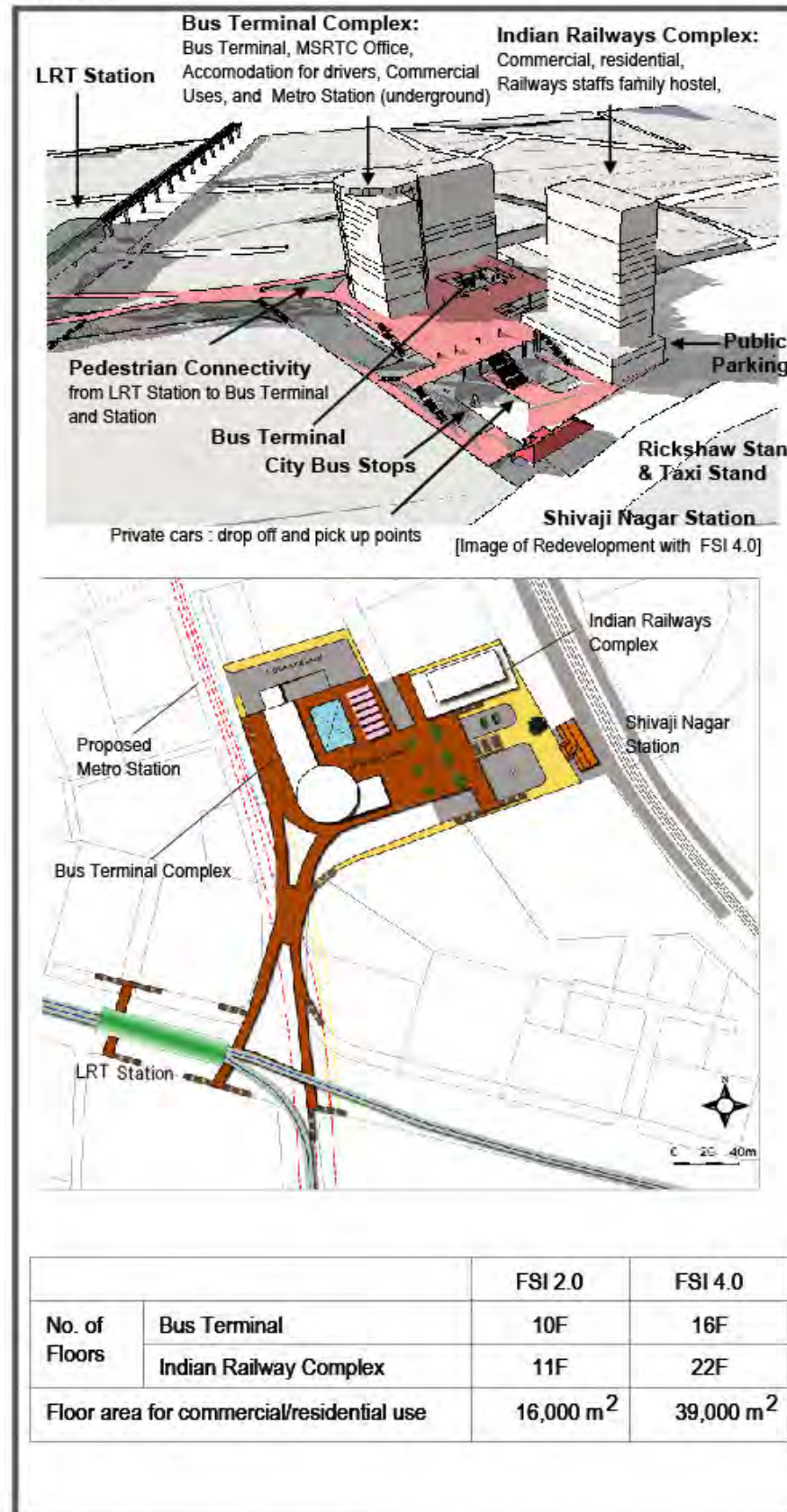

Option 3

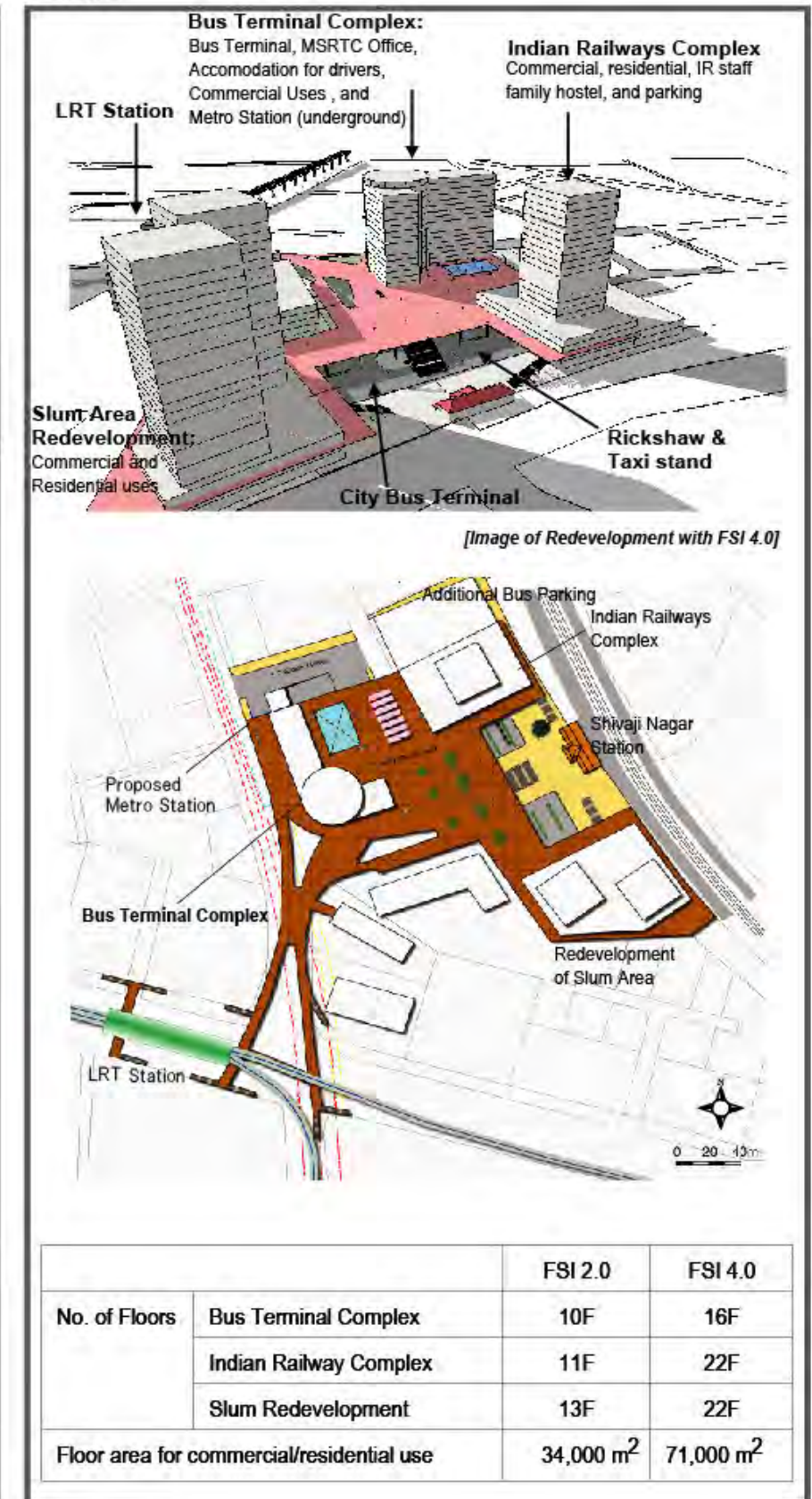

Note : Leasable area= total floor area - service area (20%)

Figure 5.6.3 Optional Scenarios for Redevelopment of Shivaji Nagar Station Area

Source: JICA Study Team

Table shows a comparison of the three options' pros and cons.

**Table 5.6.3 Comparison of the Three Options**

	Option 1	Option 2	Option 3
Pros	<ul style="list-style-type: none"> <li>* Skywalk from LRT station to Bus Terminal and Metro Station will reduce pedestrian crossings around the Bus Terminal.</li> <li>* Redevelopment of the Bus Terminal will improve its function and reduce traffic congestion/confusion around the Bus Terminal.</li> </ul>	<ul style="list-style-type: none"> <li>* Skywalk from LRT station, Bus Terminal, Metro Station, and Railway Station, will improve connectivity among several public transportation modes.</li> <li>* Capacity of Bus-Terminal will be expanded, and traffic congestion around the area will be reduced.</li> <li>* Resettlement of residents is not required. Hostel for the family members of Indian Railway staff will be in the redeveloped building.</li> </ul>	<ul style="list-style-type: none"> <li>* Re-development of the Bus Terminal, Station Plaza, Slum etc, will make rearrangement of the traffic circulation system and integration of public transportation possible.</li> <li>* Maximize utilization of area with node of public transportation with TOD Concept.</li> <li>* Redevelopment of the Slum area will improve image/impression of the Station area.</li> </ul>
Cons	<ul style="list-style-type: none"> <li>* Only Bus Terminal's redevelopment is not enough to improve the traffic congestion in the area.</li> <li>* Coordination with MSRTC and Pune Metro is required.</li> </ul>	<ul style="list-style-type: none"> <li>* Area which has high potential for re-development with node of public transportation modes will not be developed.</li> <li>* Coordination with MSRTC, Pune Metro, and Indian Railways is required.</li> </ul>	<ul style="list-style-type: none"> <li>* Resettlement of residents in Slum Area is required.</li> <li>* Coordination with MSRTC, Pune Metro, Indian Railways, and Slum redevelopment are required.</li> </ul>

Source: JICA Study Team

### (3) Summary and Issues

In order to improve the traffic circulation around the Bus Terminal and Railway Station, and improve the convenience of intermodal connectivity, redevelopment of the wider area including the Station Plaza is recommended (Option 2 or Option 3).

From the view points of effectiveness for activating the local economy, Option 3 will provide more opportunity for commercial development, and is expected to attract more private investors. However, this Option 3 requires resettlement of slum residents, and necessary procedures, including guarantees, should be discussed carefully before implementation.

For further study on the possibility and feasibility, coordination with MSRTC, the owner of the Bus Terminal, Indian Railway, the owner of land around the station, and Pune Metro SPC, is required. As Pune Metro SPC is under the process of formulation as a joint corporation of PMC, PCMC, State Government, and Indian Railway, coordination with this Pune Metro SPC will help to coordinate with MSRTC and Indian Railway as well.



### 5.6.3 St 12 State Hospital Station

#### (1) Land and Future Development Plan

St 12 State Hospital Station is planned to be located in front of the Chest Hospital in the State Hospital Site. The reasons for proposing the station at this location are summarized as follows;

Proposed new BRT Station is planned to be located in front of the Chest Hospital.

- The junction at the South Corner of the Hospital Site is the transfer point from / to buses to / from auto rickshaws, as it is the road to the residential areas such as Samarth Nagar and Kirti Nagar etc.
- Availability of the land within the Hospital Land. (limited available land in front of the General Hospital)
- As 60m of ROW for the University Road is secured in front of the State Hospital, which is an extra 15m over the typical ROW (45m) in PCMC. PCMC has a plan to construct a City Bus Terminal in the median (with 15m width), adjacent to the planned BRT Station.

Consequently, this station (St 12) seems to have a potential to be a transfer station from/to BRT, City Bus and LRT. The State Hospital Site, with an area over 20ha, contains the State General Hospital (300 beds), the Chest Hospital (200 beds), Staff Quarters, a School and College, etc. Therefore, residents and students are seen in the hospital site.

The State Hospital has a plan to develop some new hospitals/institutions in the future in the site: a center hospital, a medical university, a college of paramedics, and staff quarters. Details of this plan have not been studied yet, but the proposed location of these additional hospitals are shown in the Figure. 5.6.4



Source: Satellite Image from Google Map, Location of propose facilities from interview survey with State Hospital

**Figure 5.6.4 Future Site Layout Plan of State Hospital**

**(2) Study on the possibility of the Hospital Station**

To locate St 12 adjacent to the BRT Station and City Bus Terminal, which are planned to be in the median of the University Road, will enable integration of LRT with BRT and City Bus Services and St 12 becomes a transit station. As St 12 will be elevated, it will be connected to BRT and Bus Terminal by elevators and staircases.

A Pedestrian Overpass will provide safe access from the Hospital Site to St 12, the BRT station and City Bus Terminal. All passengers of BRT, Bus and LRT will be able to access the Hospital Site via the Pedestrian Overpass without crossing the road on the ground.

As this integrated transit station is expected to attract more passengers rather than hospital visitors, public parking for motorcycles / bicycles will be required for people from residences and students.

A transit station in front of the large hospital is assumed to have potential to develop commercial facilities. The space above the City Bus Terminal and Public Bike Parking Space are proposed to be for commercial use. It is expected that commercial developments in and near this station would have many customers, such as hospital visitors (patients, families and staff), staff in the colleges, residents who use the BRT/Bus/LRT, and future staff/visitors of the planned hospitals.

A universal design should be applied to all station buildings and pedestrian overpasses, and covered walkways within the hospital site.

In addition, due to the scattered buildings in the state hospital site, connectivity from station to each hospital building is one of the critical issues regarding accessibility. For the time being, Rickshaw stands at the station will help patients to /from the hospital buildings. But internal circulation Buses from the hospitals to the station, and a network of covered footways will be helpful.

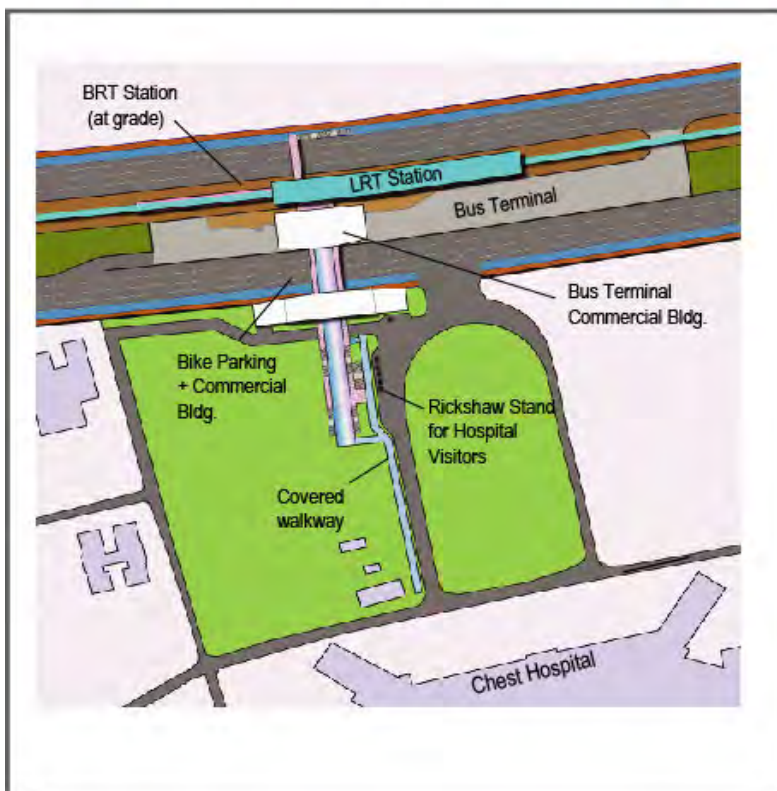
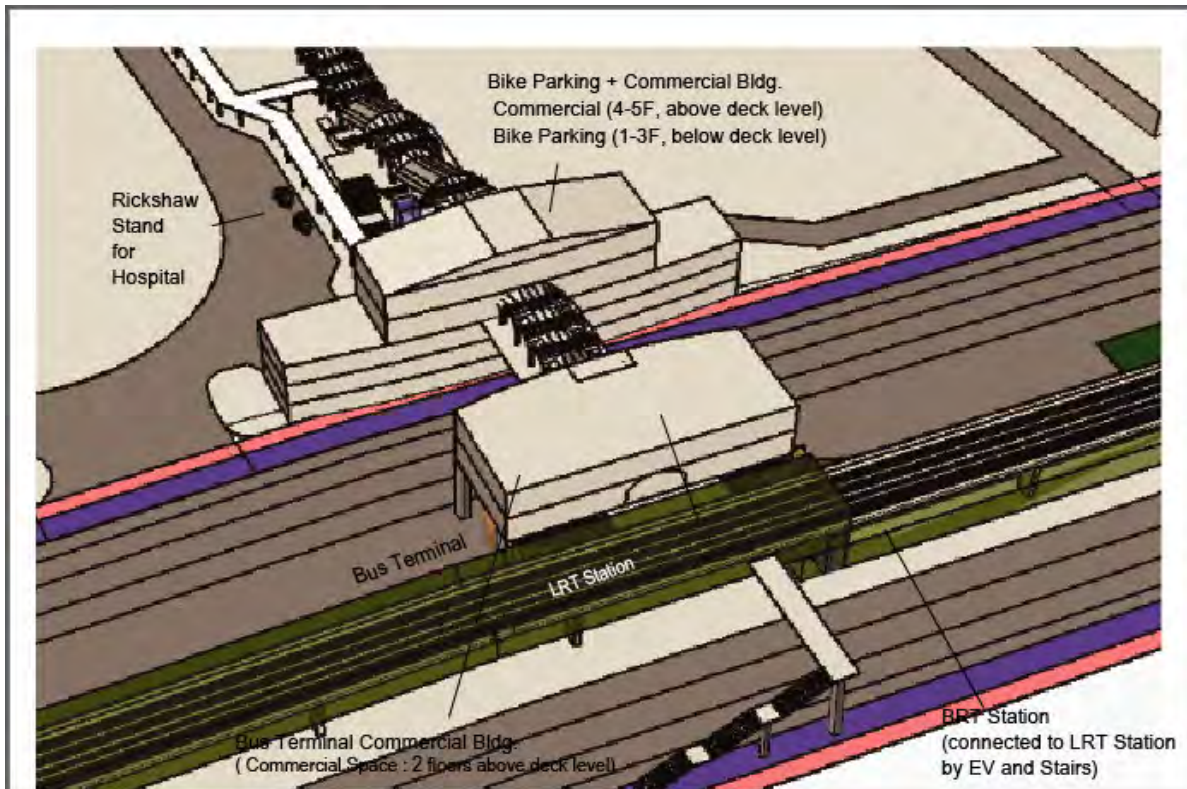

- LRT station will be located beside BRT station and Bus Terminal, these stations will be connected by staircases and elevators.
- Develop commercial building above Bus Terminal in the median.
- Develop parking building for motorbikes in the hospital site, and commercial facilities above this parking space.
- Covered walkway will be provided from station to the hospital.

		Total Floor Area
Commercial Building above Bus Terminal (2 F above Bus Terminal)		475 m <sup>2</sup>
Bike Parking Building	Commercial Space (4F,5F)	320m <sup>2</sup>
	Bike Parking Space (1F-3F) (space for 140 bikes)	900 m <sup>2</sup>
Floor area for commercial use (in total)		630 m <sup>2</sup>

Figure 5.6.5 Development Option of State Hospital Station

Source: JICA Study Team

#### 5.6.4 St 15 Wakad Chowk 2

The proposed LRT line crosses NH-4 at the JAKAT NAKA fly-over on the West side of Wakad Chowk in PCMC. This NH-4 is a route for Long Distance Buses to Mumbai, and many passengers were observed to get on/off the buses from the bus stop under the flyover. There is a public parking space for motorbikes under the flyover, and it is fully occupied in general.



People waiting for buses on NH-4 near the flyover



Bike parking space under the flyover

In the Wakad area, several large-scale new township developments are on going now, and a significant increase of population is forecast for this area. The majority of the target population of these new developments are now employees of Hinjawadi Industrial Area. However, residents that are working in PUNE but prefer to stay in the Wakad area due to the expensive housing cost in the PUNE area, are also an important target of this market.

Consequently, St 15 Wakad Chawk2 station will be a transfer station to BRT, and also be a transit point for City Buses / Long Distance Buses on NH-4. In addition, it is also expected that this station will have a high demand for Park & Ride from residents of the new township developments.

In this area, construction work on the road expansion with 45m ROW is now on going, and acquisition of the land and demolition of the buildings has been started. On the other hand, new housing buildings are under construction along the road. Currently, most of the lands along the street are categorized as “residential” in the PCMC land use plan. As most of the lands are owned by private owners, the available land has not been confirmed yet in this area, therefore, the possibility to develop a Park & Ride facility is studied with temporary sites as shown in Figure.5.6.8.

For this study, F.S.I 1.8, which is for the area along a BRT corridor is applied.

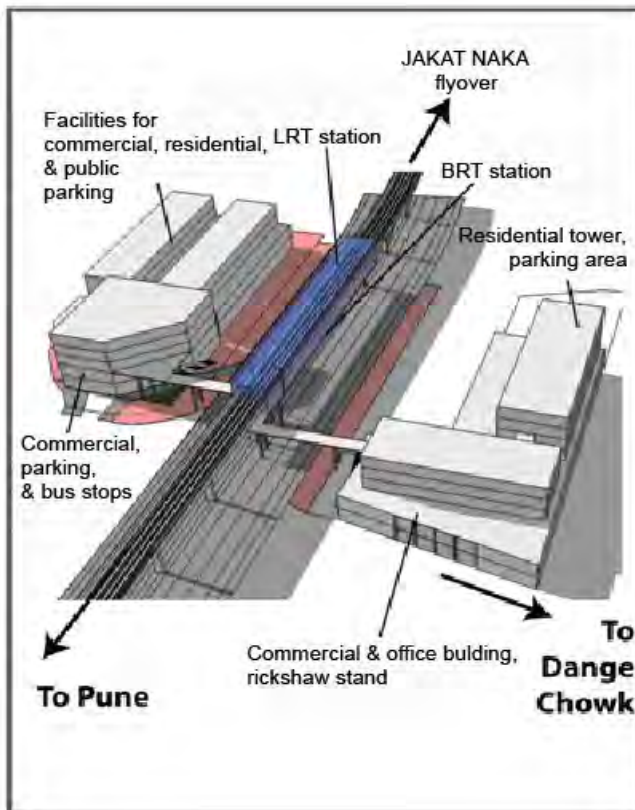
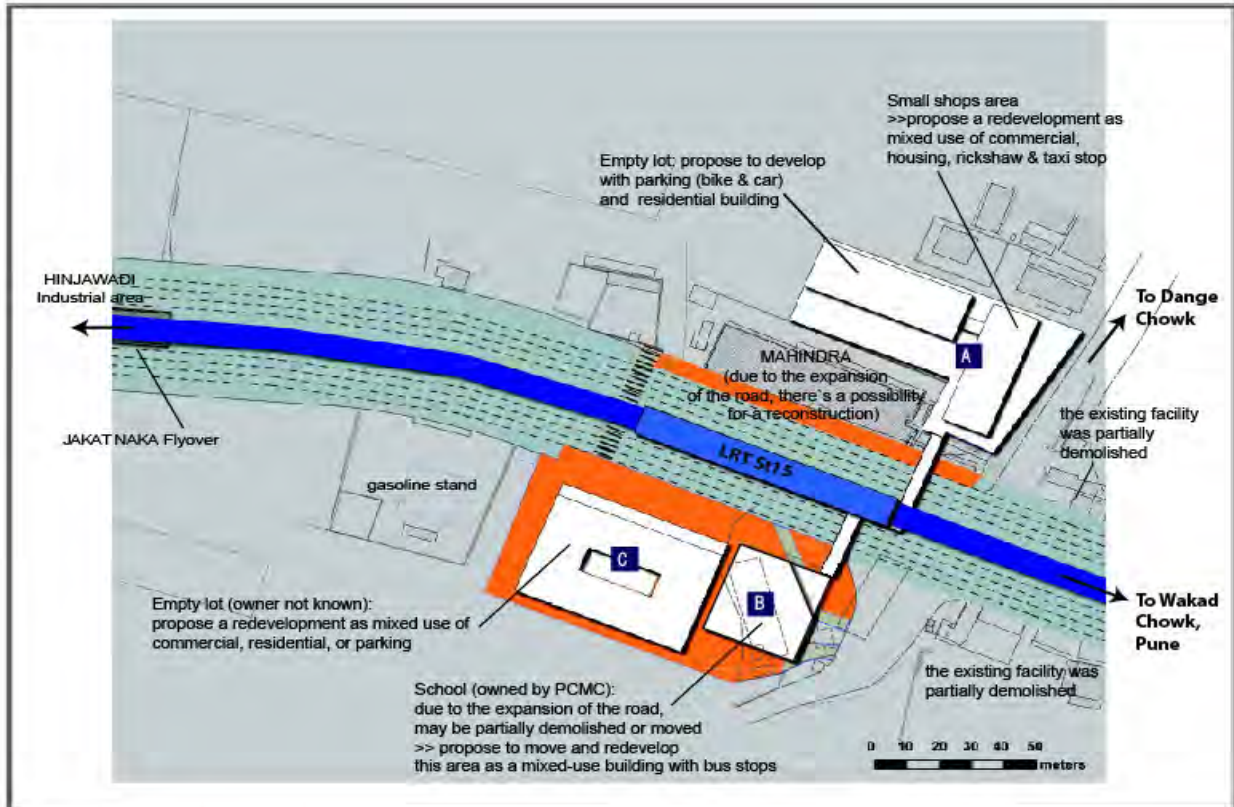

	Floor use	Number of Floors & Potential Floor Areas for Commercial Use	
Site A	Commercial, office	1-5F	2,700 m <sup>2</sup>
	Residential	4-8F	3,400 m <sup>2</sup>
	Public parking space	Bicycles Bikes Outdoor: Cars	60 300 45
Site B	Commercial, office	2-5F	2,500 m <sup>2</sup>
	Public parking space	Indoor: Bikes	110
Site C	Commercial	2-3F	1,300 m <sup>2</sup>
	Residential	4-5F	3,200 m <sup>2</sup>
	Public parking space	Bikes	300

Figure 5.6.6 Study on development of P&R facilities at St.15

Source: JICA Study Team

## 5.7 Construction Plan

### 5.7.1 Elevated Area

For the elevated area, the main issues and subject location are pointed out as follows;

- Erection method for PC-Box Girders
- Construction Plan for Typical Elevated Station
- Station-5 adjacent to Road Flyover Structure
- Intersection with National Highway-4
- MULA River Bridge

#### 1) Erection Method for PC Girders

Basically, the Cast-on-stage method and pre-cast segment method will be employed for the construction of the PC girders. And also the track crane method or other method will be adapted depending on site condition.

##### (1) Cast-on-stage Method

###### Technical Features

- ✓ The method is carried out by installing a stage supporting the cast-in-place girder on the ground. It is the most popular erection method.
- ✓ Assembling of a temporary stage, fabrication girder, and dismantling of the stage are repeated for each interval construction section which contains a single or multi span.
- ✓ The method can be used to fabricate curved girders.
- ✓ Suitable in the conditions where there are no obstacles below the girders.
- ✓ Stiff ground condition which is able to support the temporary stage is required.



**Figure 5.7.1 Image of Construction by Cast-on-stage method**

Source: Japan Hopepage of Civil Engineering Contractors Association, Inc. /  
Building of the Pier in the Project of Purple-Line, Bangkok

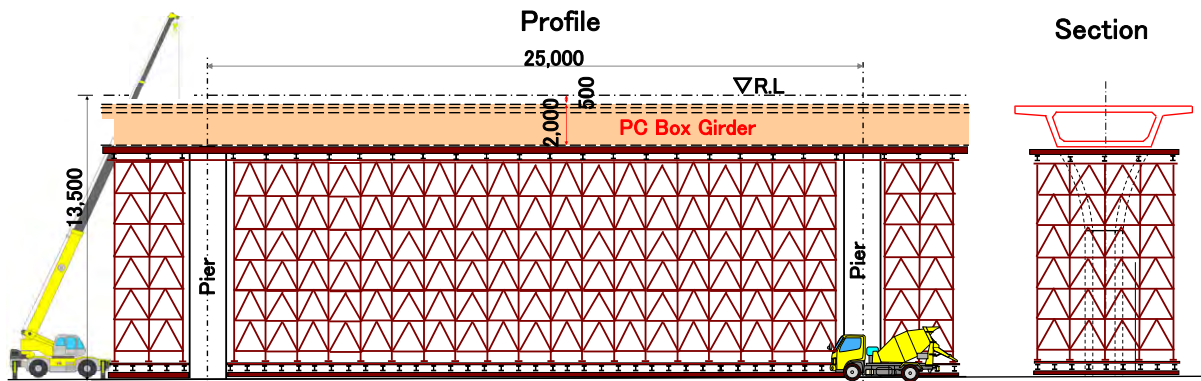

**Figure 5.7.2 Profile and Section of Cast-on-stage method**

Source: JICA Study Team

## (2) Pre-cast Segment Method

### Technical Features

- ✓ The method is employed to relatively large-sized bridges, such as long length viaducts in urban areas or expressways. The method requires preparation of a fabrication yard which can intensively produce numerous precast segments in a short period.
- ✓ Segment fabrication and erection work are a constant repetition of the cycle, therefore, over time an increase in the workmen's skill can be expected.
- ✓ From division of labor between mechanized production and girder erection, significant reduction in the erection period is possible
- ✓ The Central Control by mechanized erection equipment can ensure consistent quality.
- ✓ Since there is a standard post-fabrication period for the segments, deformation by dry-shrinkage and creep can be reduced after erection of the girder.
- ✓ Also in the report of the Pune Metro plan, the method has been proposed for elevated sections

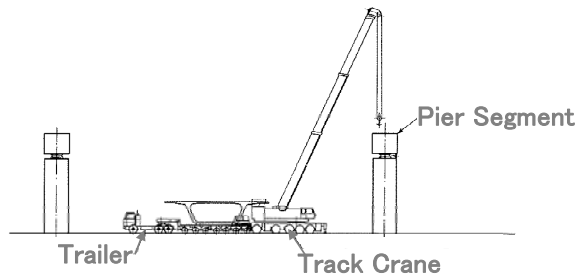

**Figure 5.7.3 Image of construction by precast segment method**

Source: FUJI P.S CORPORATION HomePage/Building of Nabeta Bridge in the Second Tokyo-Nagoya Expressway, 2000 Japan

**Procedure of Girder Erection**

**Stet 1 : Install Pier Segment**



**Stet 2 : Transport and Set Erection Girder**

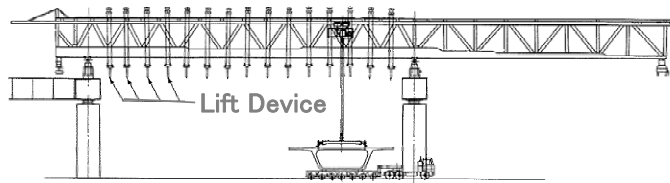

**Stet 3 : Lift Segment**

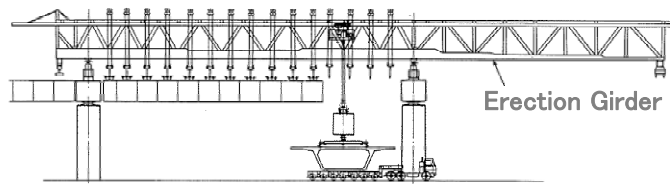

**Stet 4 : Arrange Alignment of Segments, Work of Unreinforced**

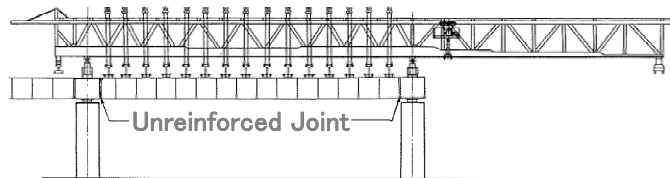

**Stet 5 : Tensioning**

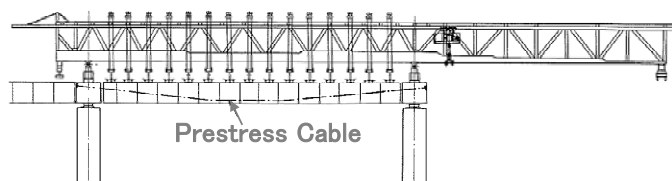

**Stet 6 : Transport Erection Girder for Next Span**

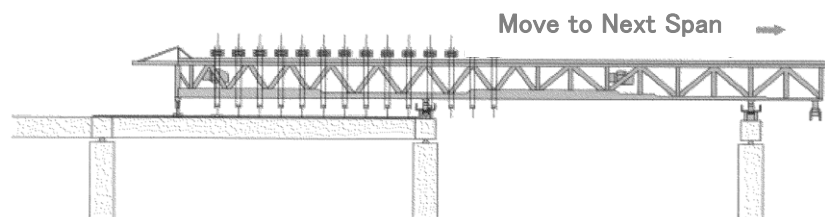



## 2) Construction Plan for Typical Elevated Station

The typical elevated station is planned to be built in a widened space in the road median strip. The section of elevated station and road lane after completion are shown below.

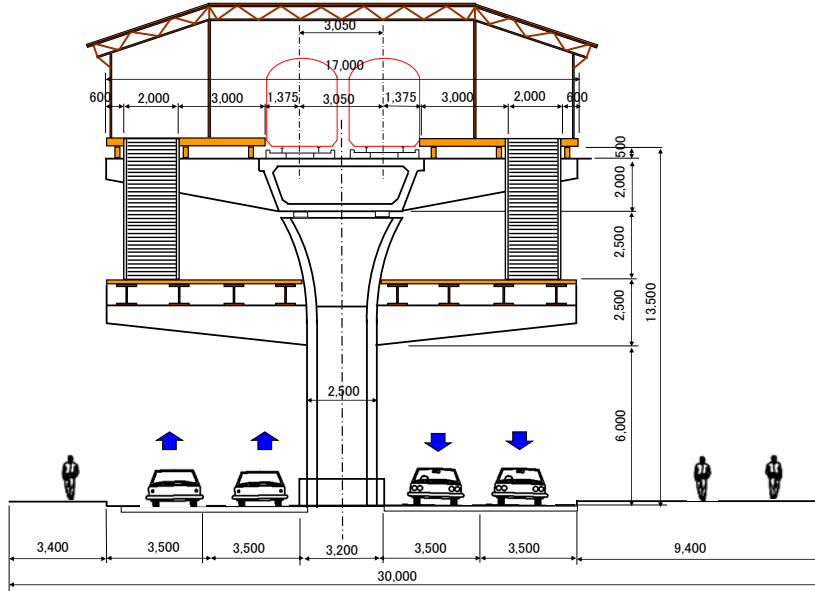

For example, Construction procedure on the Station-9 is examined as follows.

### (1) Existing Condition

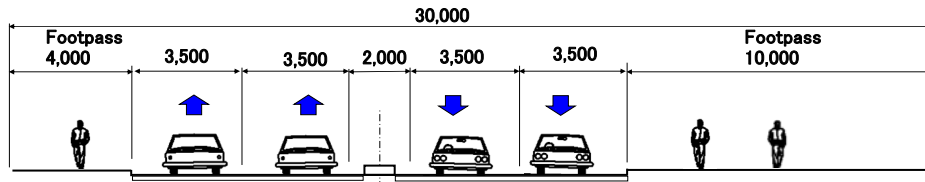

### (2) Excavation, Build Footing and Leg of Column

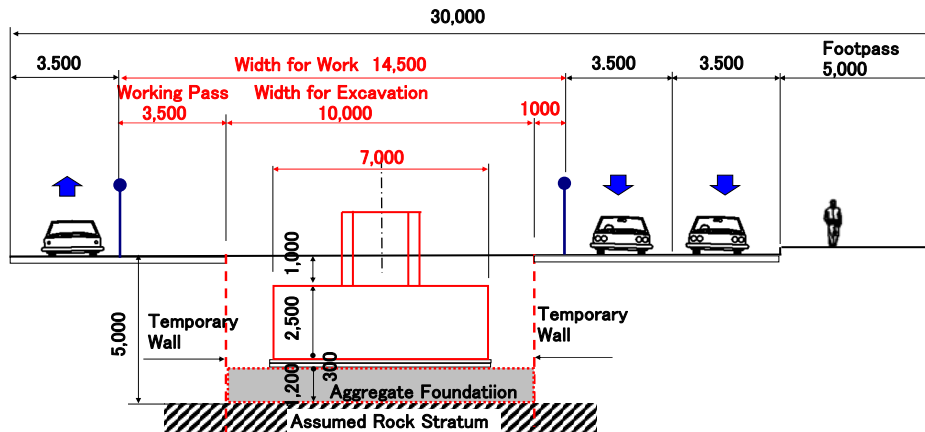

**(3) Build Column**

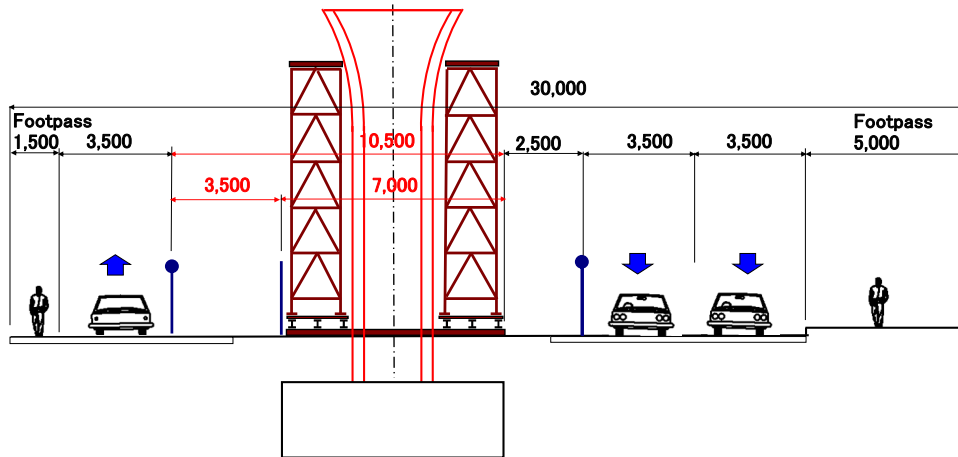

**(4) Erection of PC-Girder**

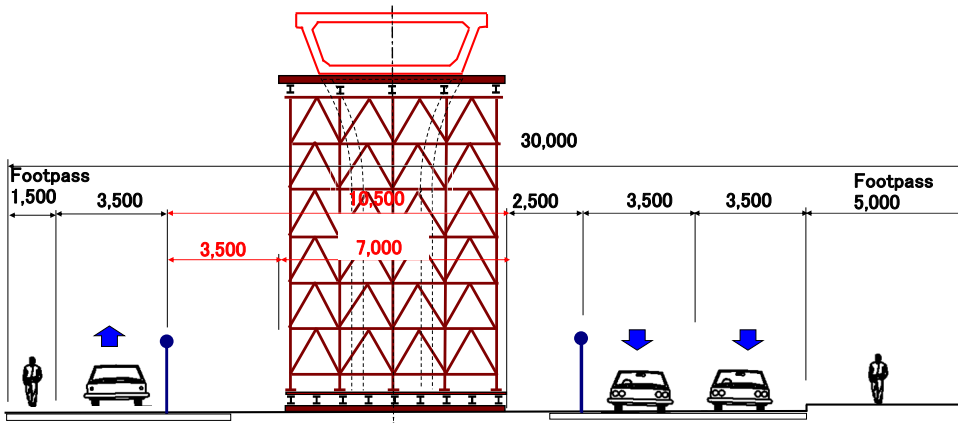

**(5) Build Concourse Beam**

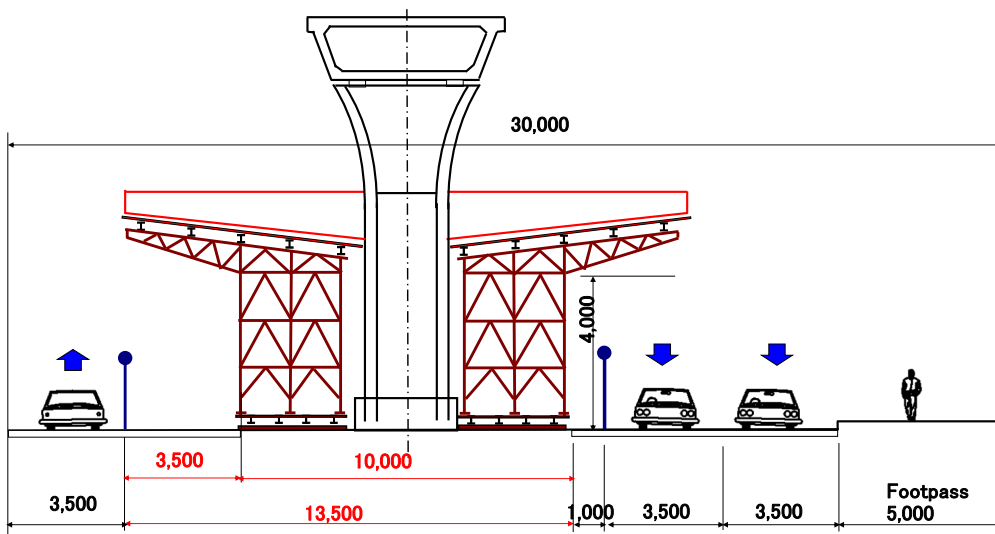

**(6) Work of Platform Beam**

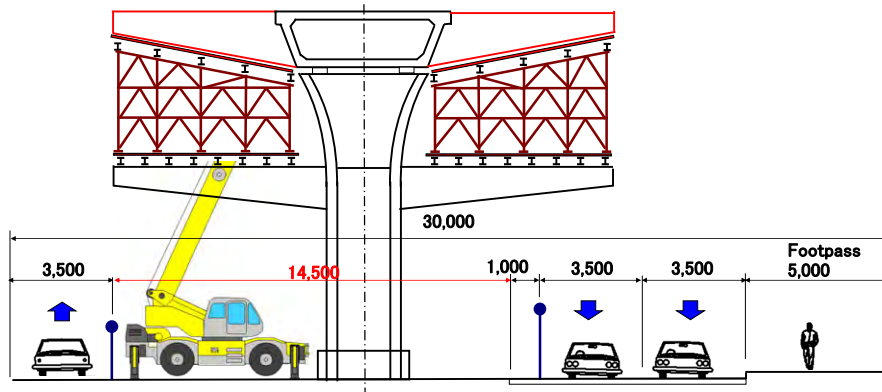

**(7) Work of Rail, Platform and Roof**

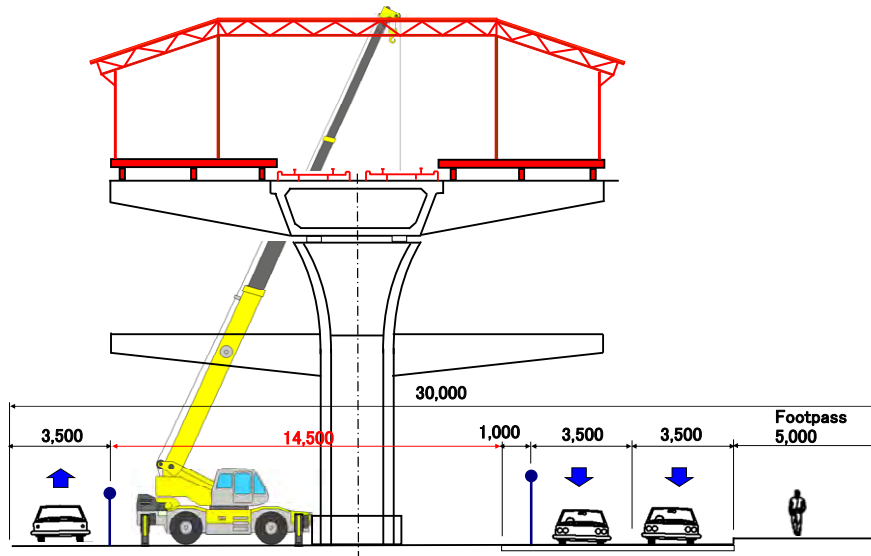

**(8) Work of Concourse floor and Lift Utilities**

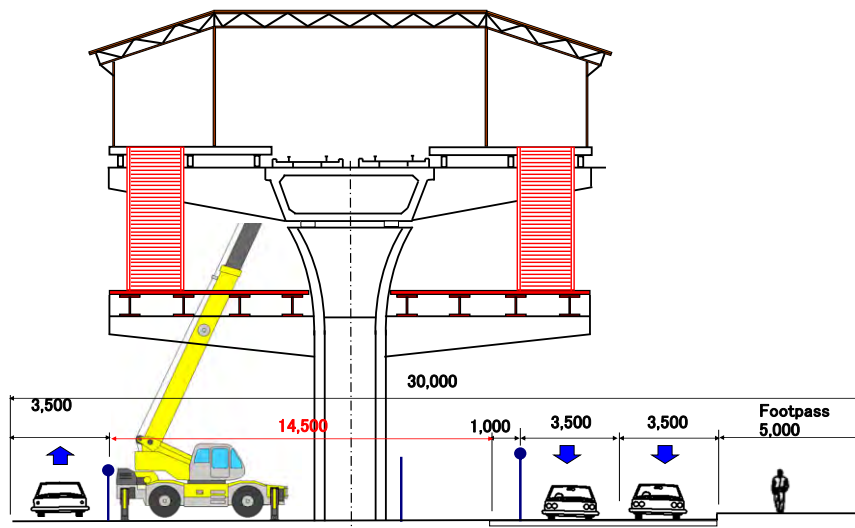

**(9) Completion**

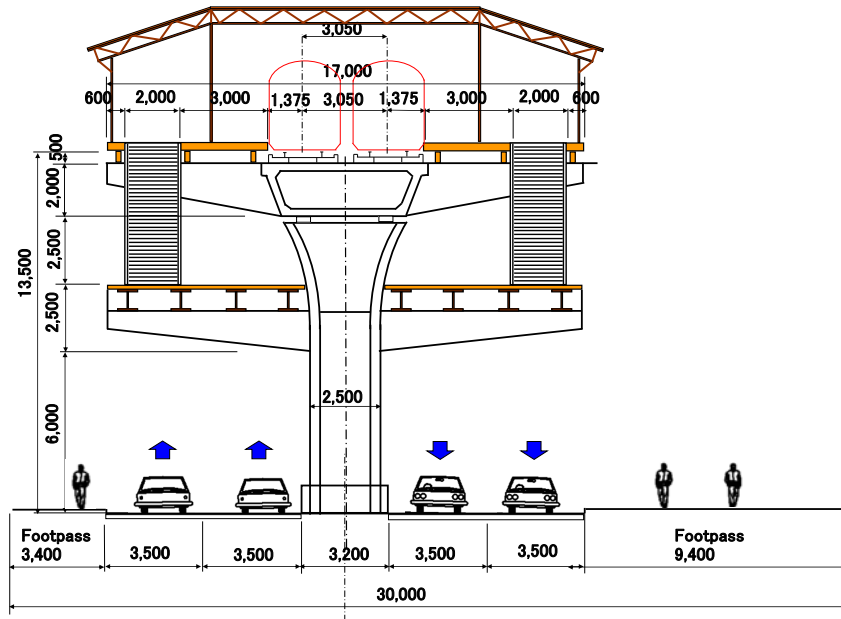

**3) Station-5 adjacent to Road Flyover Structure**

Station-5 is planned to be located close to an existing road flyover, therefore the construction of station-5 is expected to be done in difficult and congested conditions. The section of elevated station and road lane after completion is shown below.

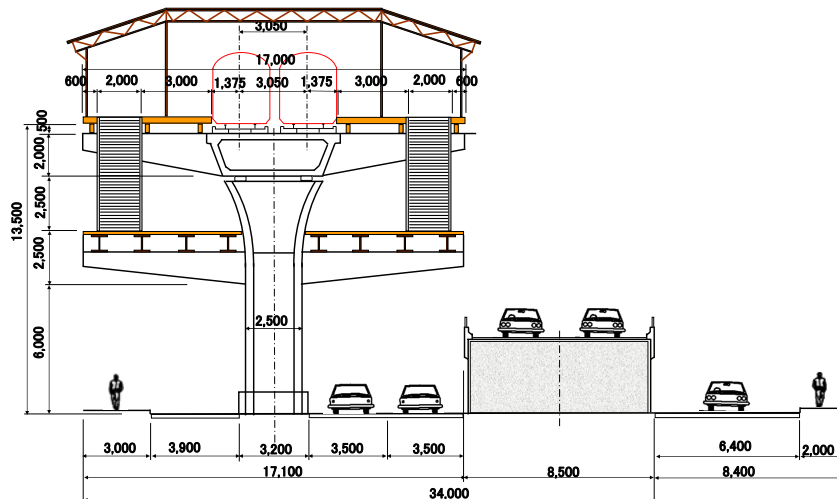

**Figure 5.7.4 Station-5**

To ensuring construction space and to make the impact on traffic as small as possible, the Construction procedure is planned as below;

(1) Existing Condition



Source: JICA Study Team

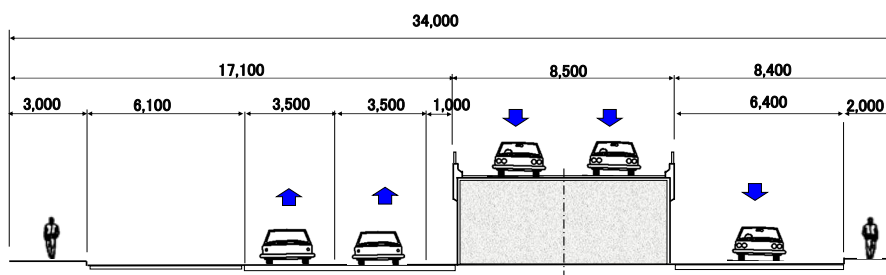

(2) Excavation, Build Footing and Leg of Column

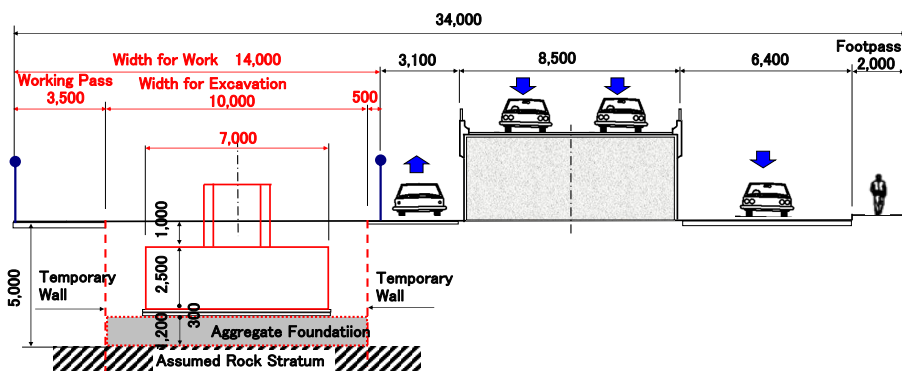

(3) Build Column

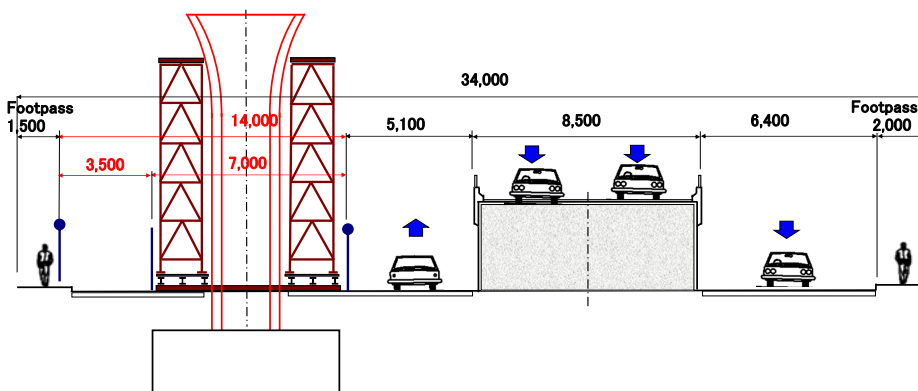

**(4) Erection of PC-Girder**

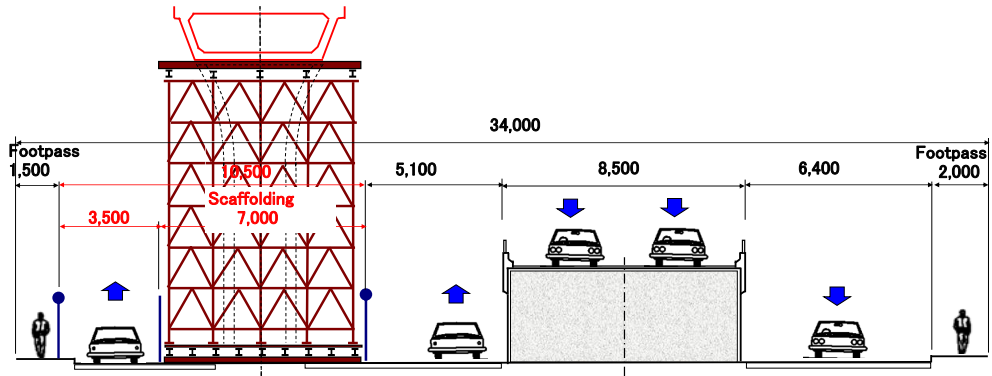

**(5) Build Concourse Beam**

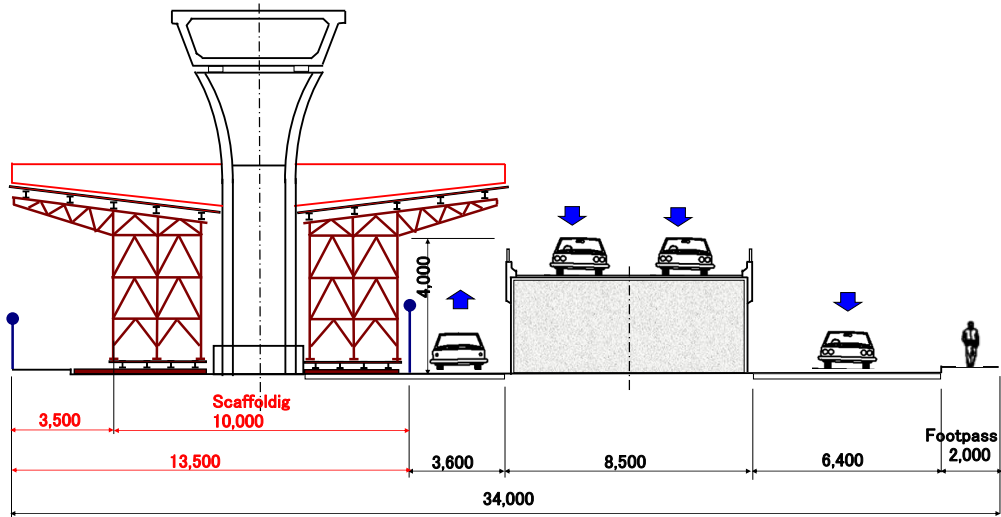

**(6) Work of Platform Beam**

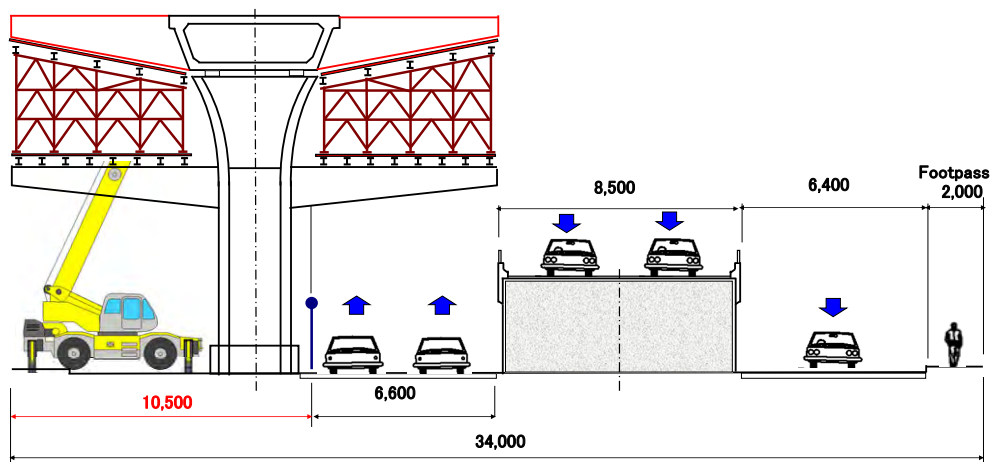

**(7) Work of Rail, Platform and Roof**

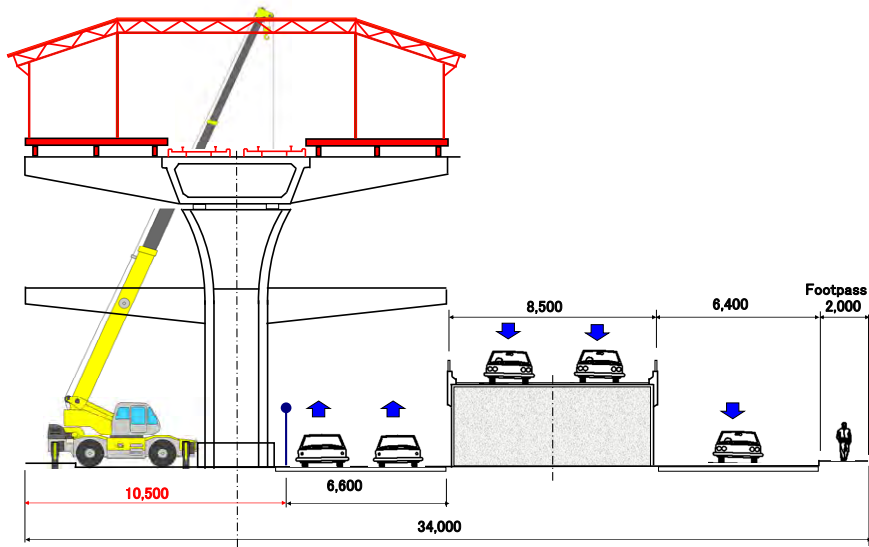

**(8) Work of Concourse floor and Lift Equipment**

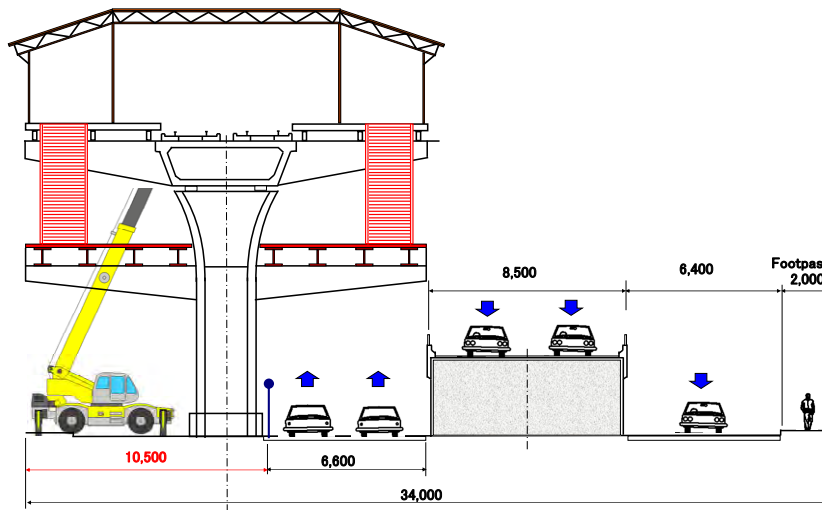

**(9) Completion**

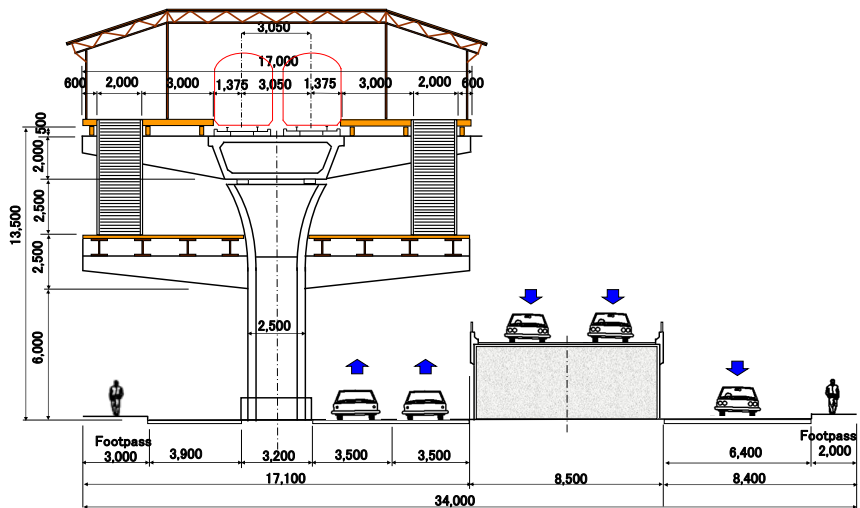

**4) Intersection with National Highway-4**

The existing road viaduct crosses over National Highway-4 at an intersection where many vehicles drive through. An elevated railway is planned to run at a higher elevation on parallel alignment with the road viaduct. Constriction is required to be planned so that it does not stop existing road traffic. Construction procedure in the intersection is planned as below;

**(1) Existing Condition**

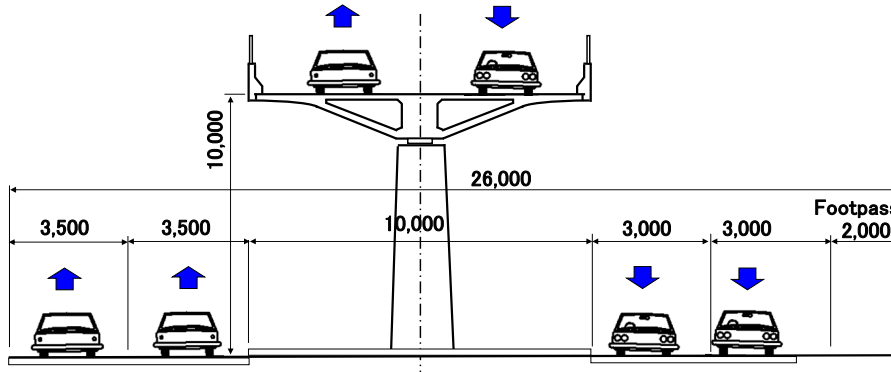

**Existing Section of NH4**

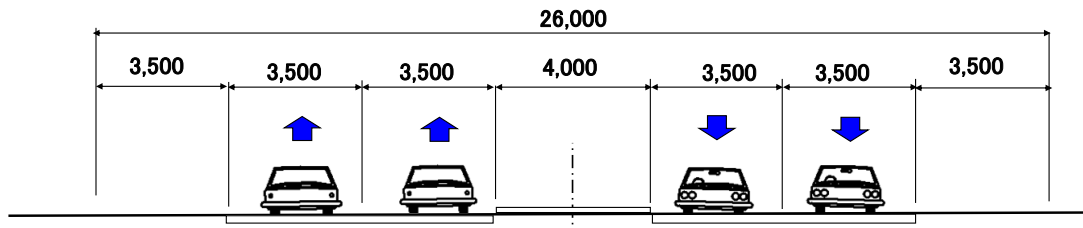

**(2) Excavation, Build Footing and Leg of Column**

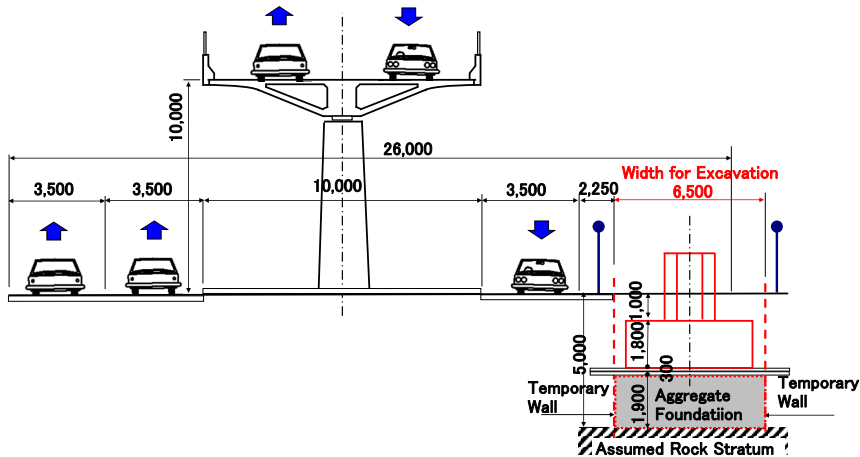



**(3) Build Column**

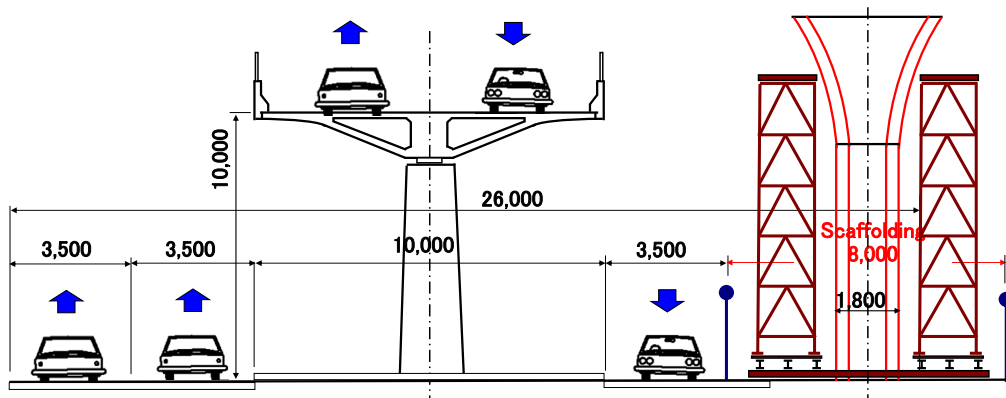

**(4) Erection of PC-Girder**

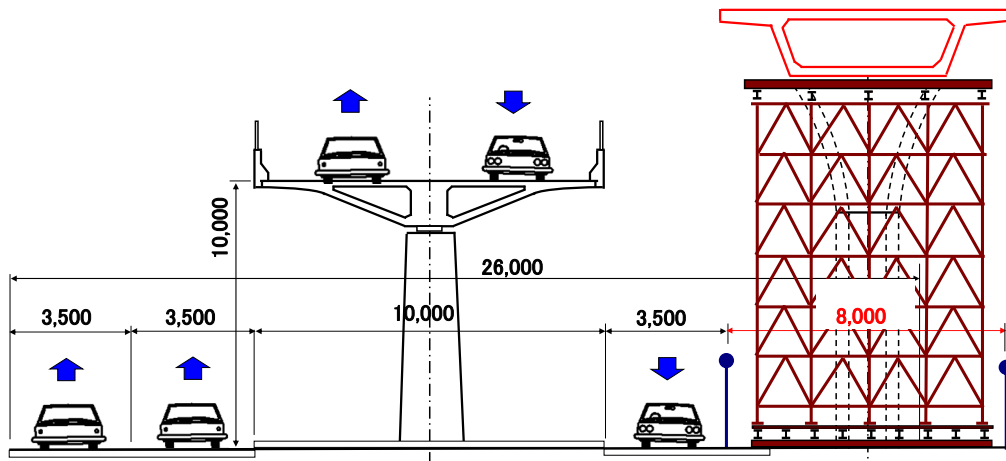

**Section of NH4 at Erected Girder**

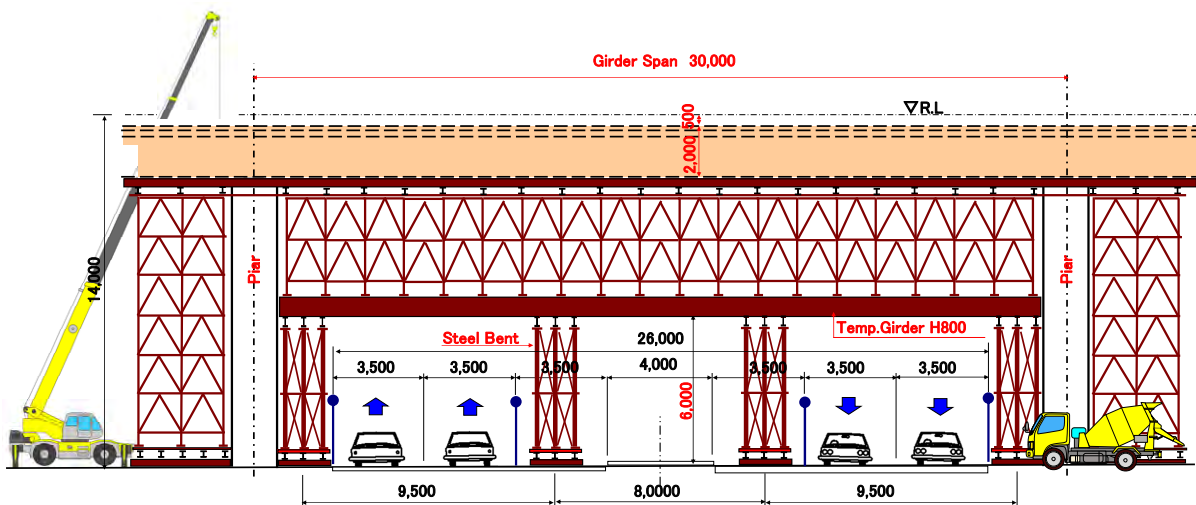

(5) Completion

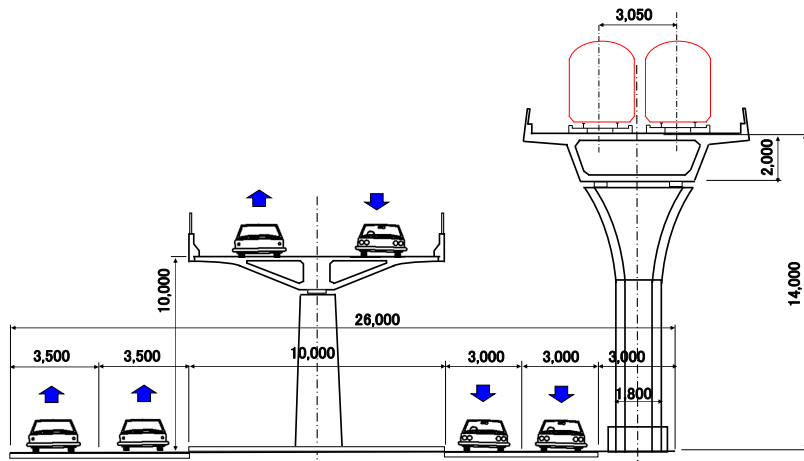

Section of NH4 at Completion

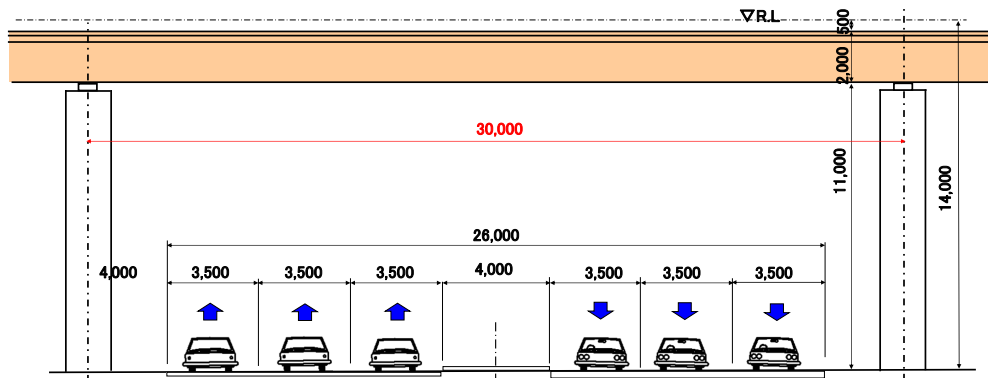

Plan of NH4 at Completion

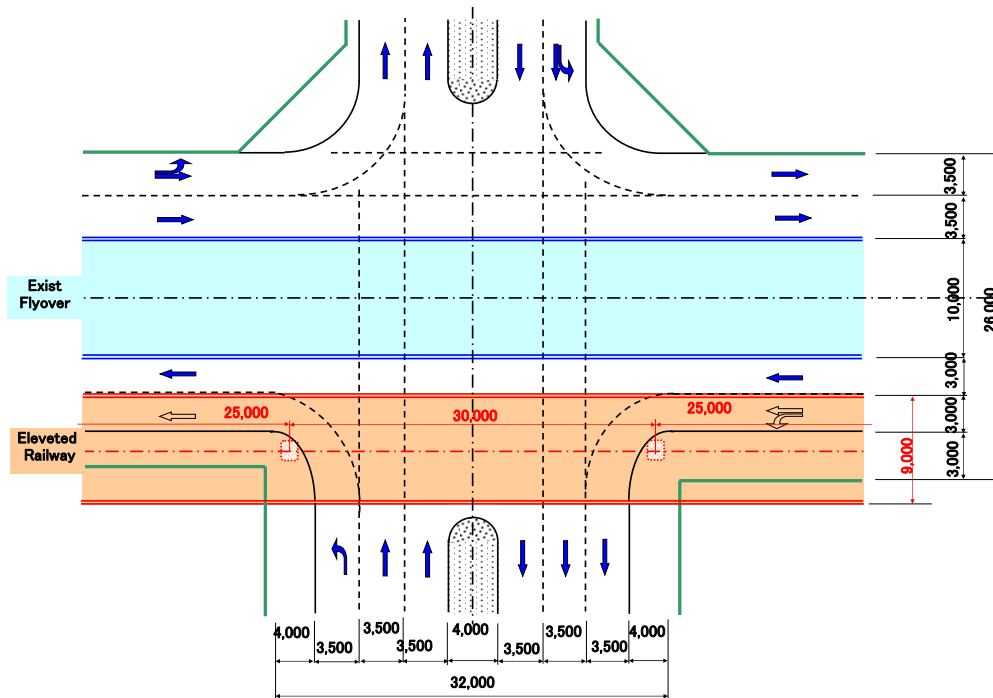

**5) MULA River Bridge**

Two feasible methods can be planned. One is the plan for setting typical span girders the same as the other elevated sections, and the other is the plan for a long continuous girder for the purpose of reducing the number of piers constructed in the river. The latter construction plan using the cantilever method, which is generally employed for River Bridges, is examined below. Source: Construction Step Figures shown below are made by Study Team



**Figure 5.7.5 Image of Cantilever method**

Source: Homepage of Simizu Corporation/  
Cantilever Erection System

**(1) Build Temporary Bridge**

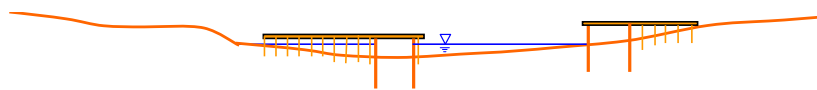

**(2) Build Temporary cofferdam and Foundation of Piers**

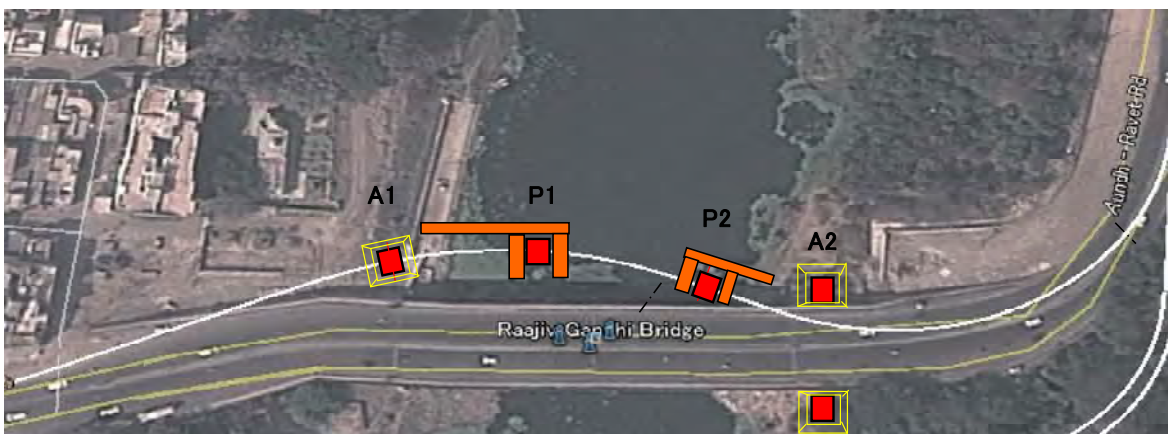
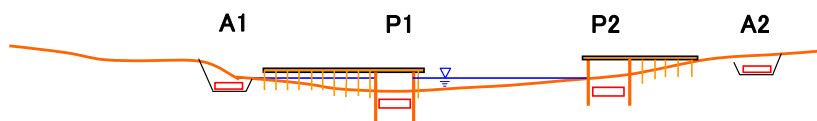

**(3) Build Pier Column**

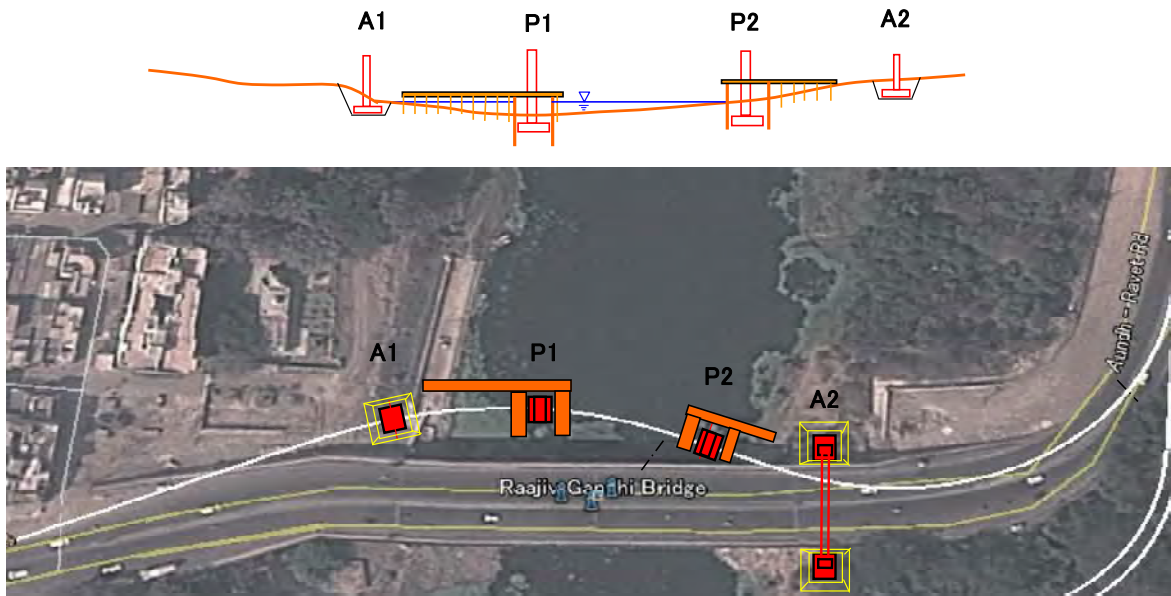

**(4) Build Segment on Pier-head**

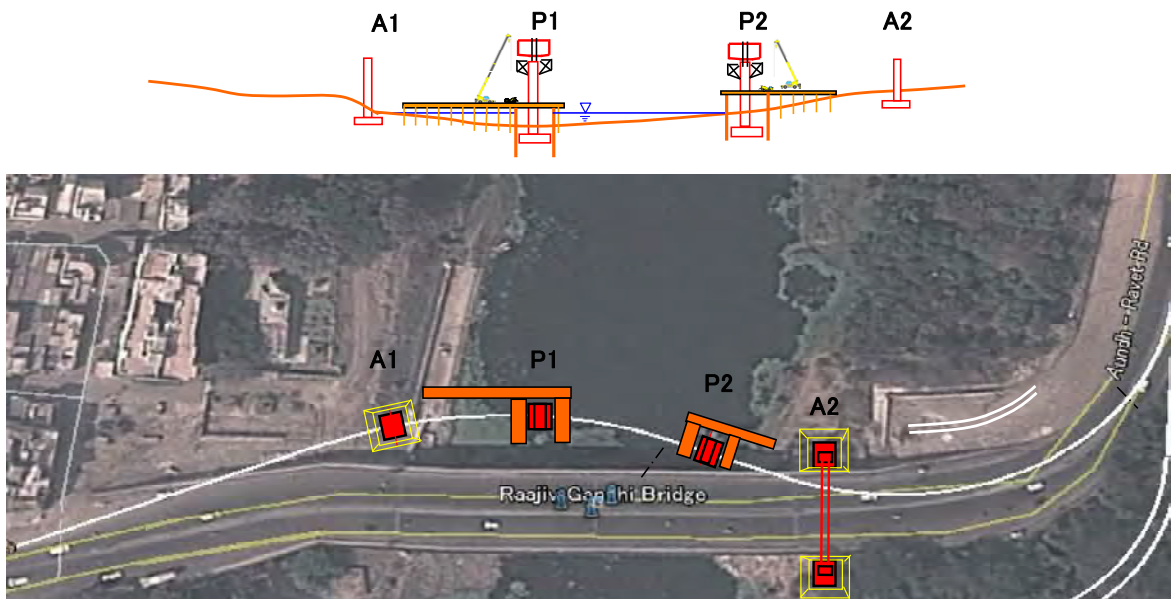

(5) Erection by Cantilever

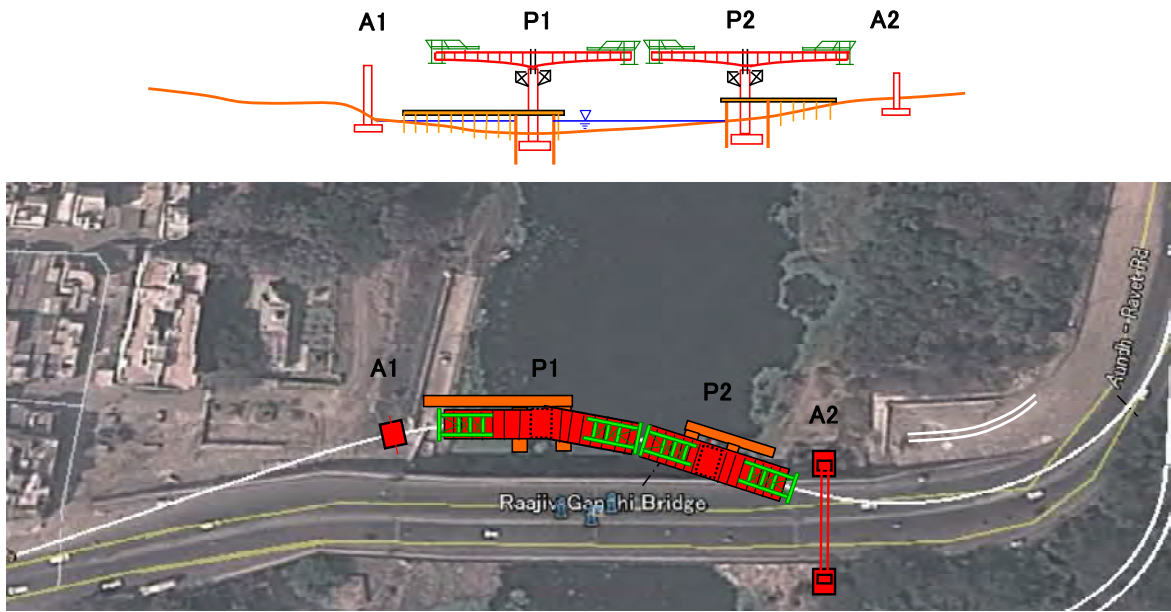

(6) Construction of side of span on temporary stage

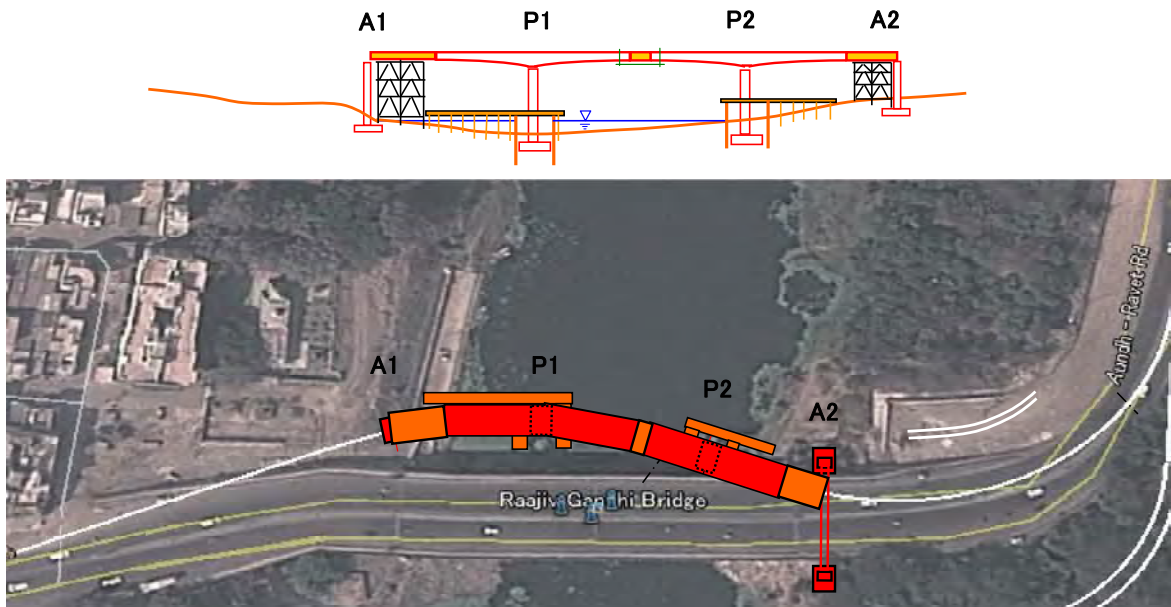

(7) Completion

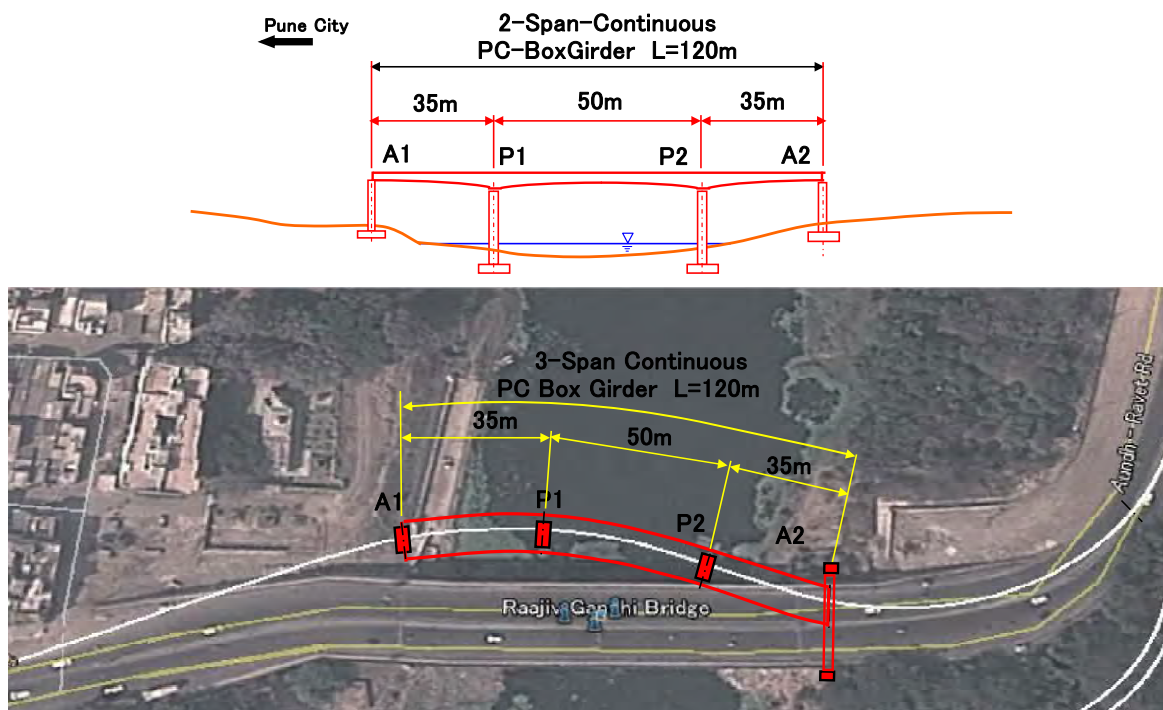

5.7.2 Land Acquisition

To implement this LRT project, land acquisition will be required and these land acquisitions are shown in Table 5.7.1

Table 5.7.1 Land Acquisition Plan

St. No.	Site	Kilo post	Current condition	Reasons	Size of land acquisition
1	Roadside area in PMC in southern part of Mula River	5K900M ~ 5K980M and 6K200M ~ 6K350M	There are many buildings along the two lane road.	Land acquisition is required for the construction of a flyover bridge and elevated station. Width is approx. 3.2 m and length is approx. 230 m.	Approx. 740m <sup>2</sup>
2	Around NH-4	13K020M ~ 13K520M	There are public spaces along the two lane road.	Land acquisition is required to maintain the current road lanes and for the construction of a flyover bridge. Width is approx. 8.0 m and length is approx. 500 m.	Approx. 4,000m <sup>2</sup>
3	Hinjawadi IT Park Phase 4 area	16K900M	Planned phase 4 areas are currently private areas.	Land acquisition is required for the construction of a rail yard and St. 18.	Approx. 11,000m <sup>2</sup>
4	Hinjawadi IT Park from Phase 1 to Phase 3 area	15K400M ~ 21K400M	There are two lane roads with dividing strips and pedestrian sidewalks in some portions with gaps.	Land acquisition is required for the construction of a flyover bridge and elevated station. Width is approx. 3.2 m and length is approx. 6,000 m.	Approx. 19,680m <sup>2</sup>
Total size of land acquisition					Approx. 134,420m <sup>2</sup>

Source: JICA Study Team

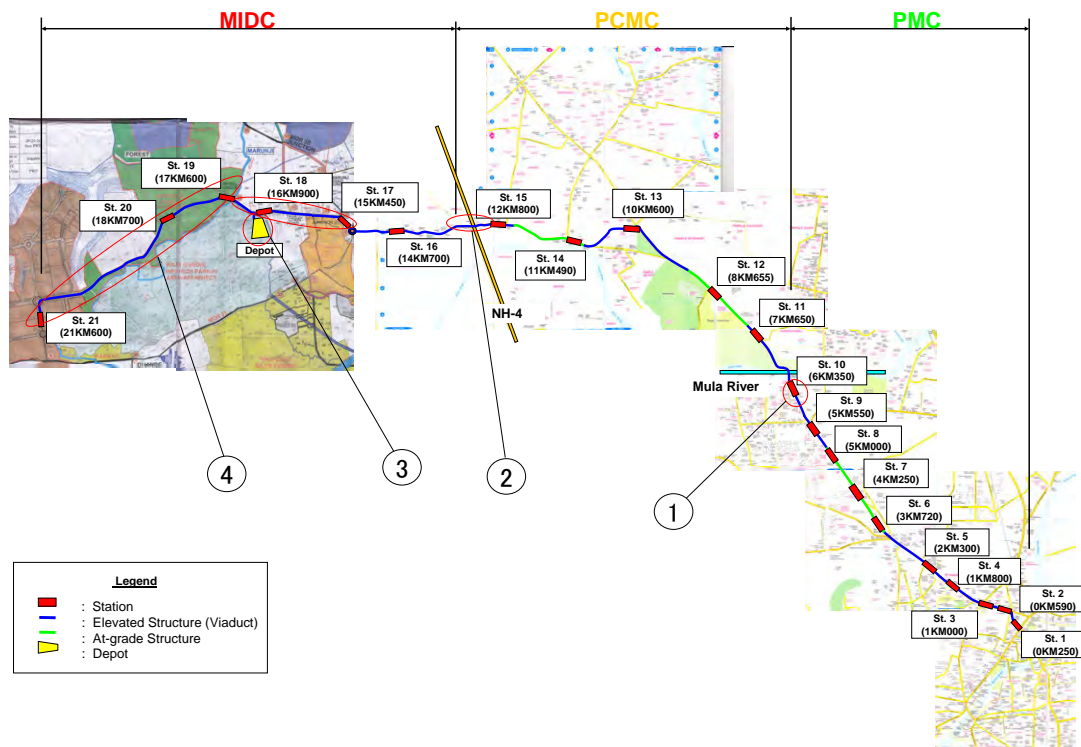

Figure 5.7.6 Location of Land Acquisition

Source: JICA Study Team

## 5.8 Schedule for Implementation

### 5.8.1 Schedule before the Construction

The items that shall be implemented before the start of construction are the Feasibility Study, Basic design, preparation of EIA, financial arrangements, preparation work, establishment of an administration organization, selection of the consultants and selection of the contractor. Some of these items will be divided into more detailed procedures. Schedules for these items are shown in Table 5.8.1. The Feasibility study, basic design and preparation of EIA are to be implemented in the middle of 2013. Selection of the contractor will be completed in the middle of 2016.

### 5.8.2 Construction Schedule

A gradual start of operation that has two phases is proposed for the targeted first operation before the end of 2018. The first phase (phase 1) is the section from St.5 to St. 18 with the length of 14.6km and construction will be started from the middle of 2016. Test runs will be completed before the end of 2018. The second phase (phase 2) are the sections from St. 1 to St. 5 and St. 18 to St. 21 with the length of 6.75km. Construction will commence in 2018 and will be completed before the end of 2020. These phase 1 and phase 2 and schedule for construction procedures are shown in Figure 5.8.1 and Table 5.8.1.

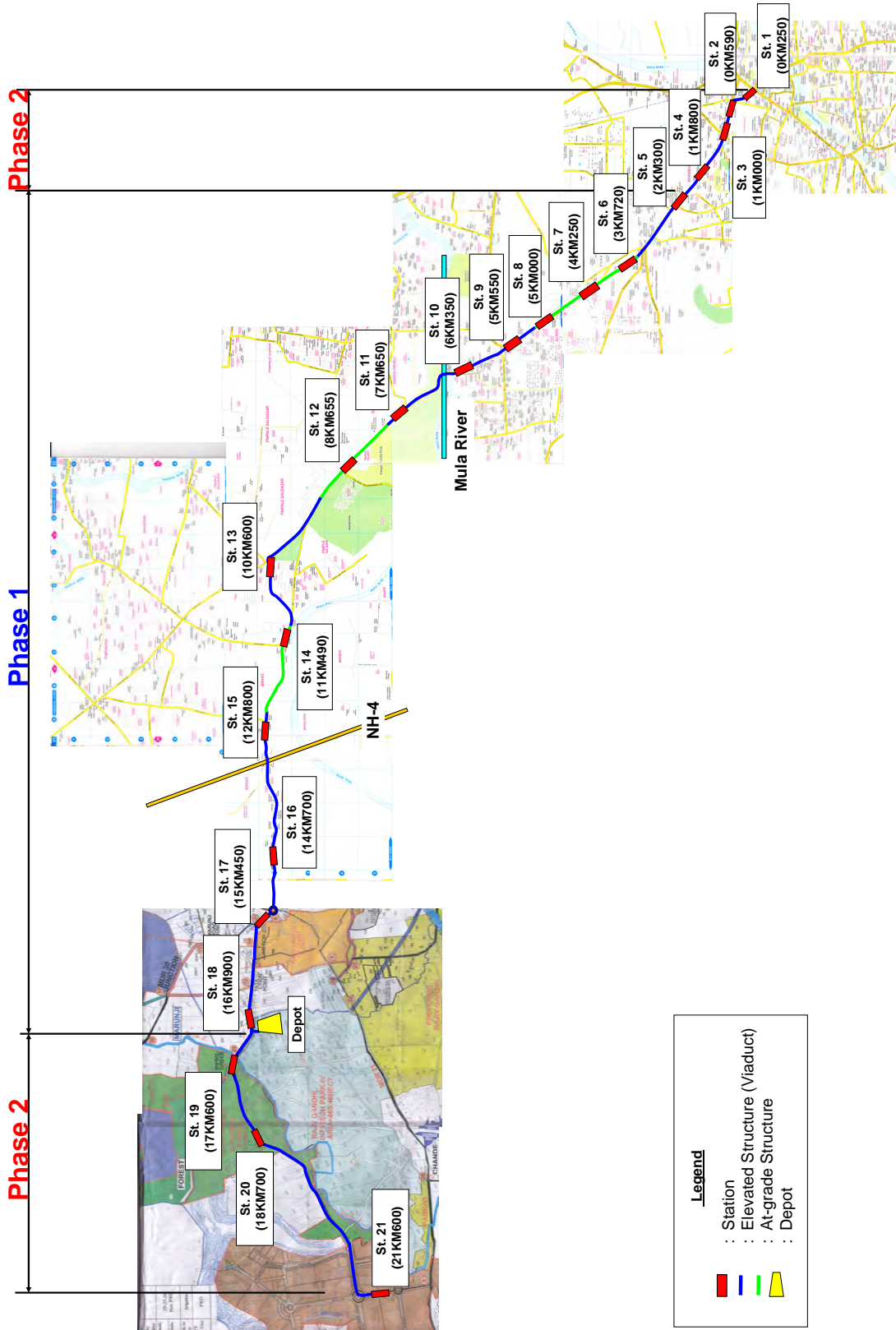

Source: JICA Study Team

Figure 5.8.1 Construction and Operation Phase



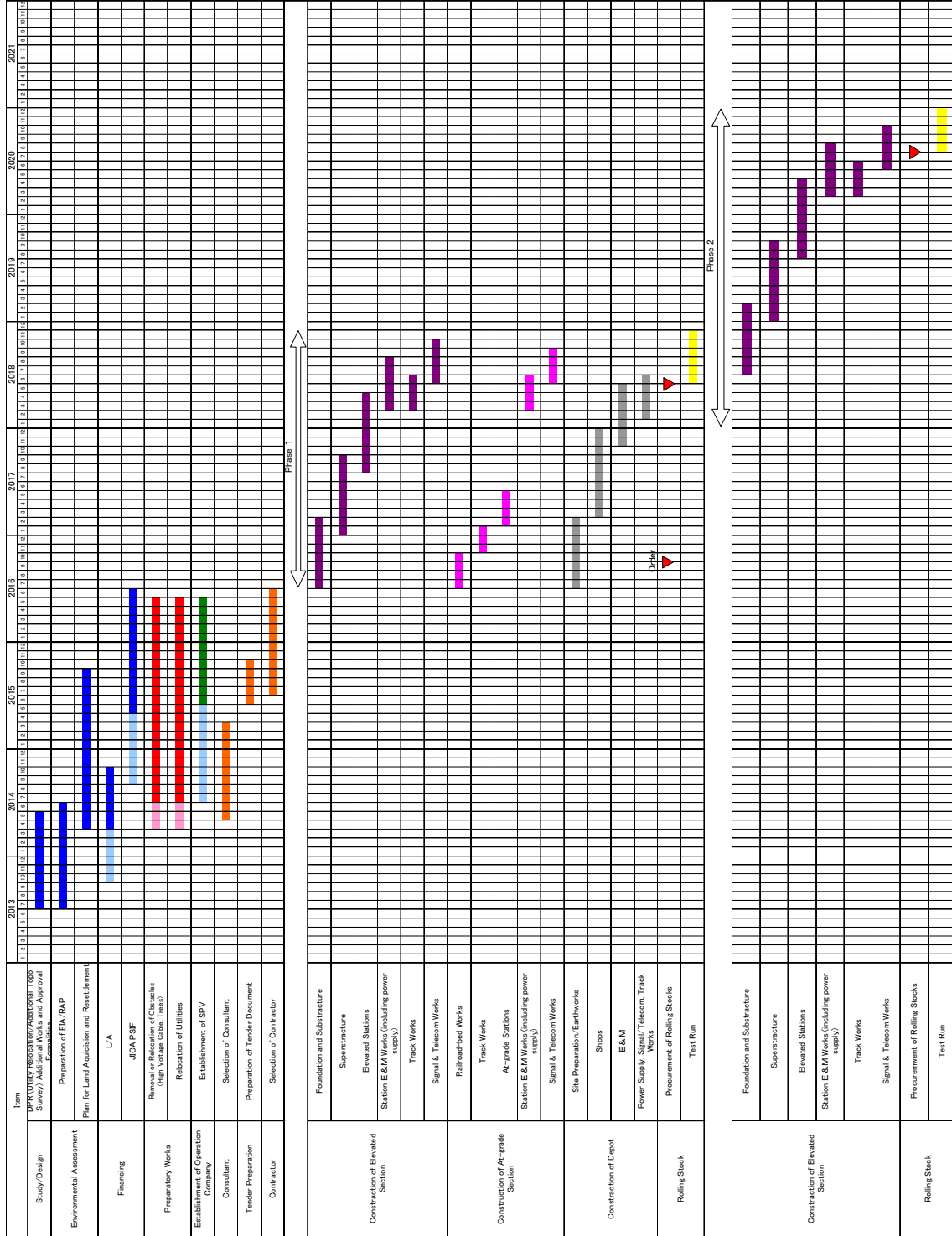

Table 5.8.1 Implementation Schedule

Source: JICA Study Team