

**PREPARATORY SURVEY FOR  
METRO MANILA INTERCHANGE  
CONSTRUCTION PROJECT (VI)  
IN THE REPUBLIC OF  
THE PHILIPPINES**

**FINAL REPORT  
SUMMARY  
(SIMPLE BINDING)**

**NOVEMBER 2012**

**JAPAN INTERNATIONAL COOPERATION AGENCY**

---

**KATAHIRA & ENGINEERS INTERNATIONAL  
ORIENTAL CONSULTANTS CO., LTD.  
NIPPON ENGINEERING CONSULTANTS CO., LTD.**

<b>EI</b>
<b>JR(先)</b>
<b>12-213</b>

*Exchange Rate*

*Date: Nov. 2012*

*PHP 1 = JPY 1.87*

*USD 1 = JPY 78.20*

*USD 1 = PHP 41.70*

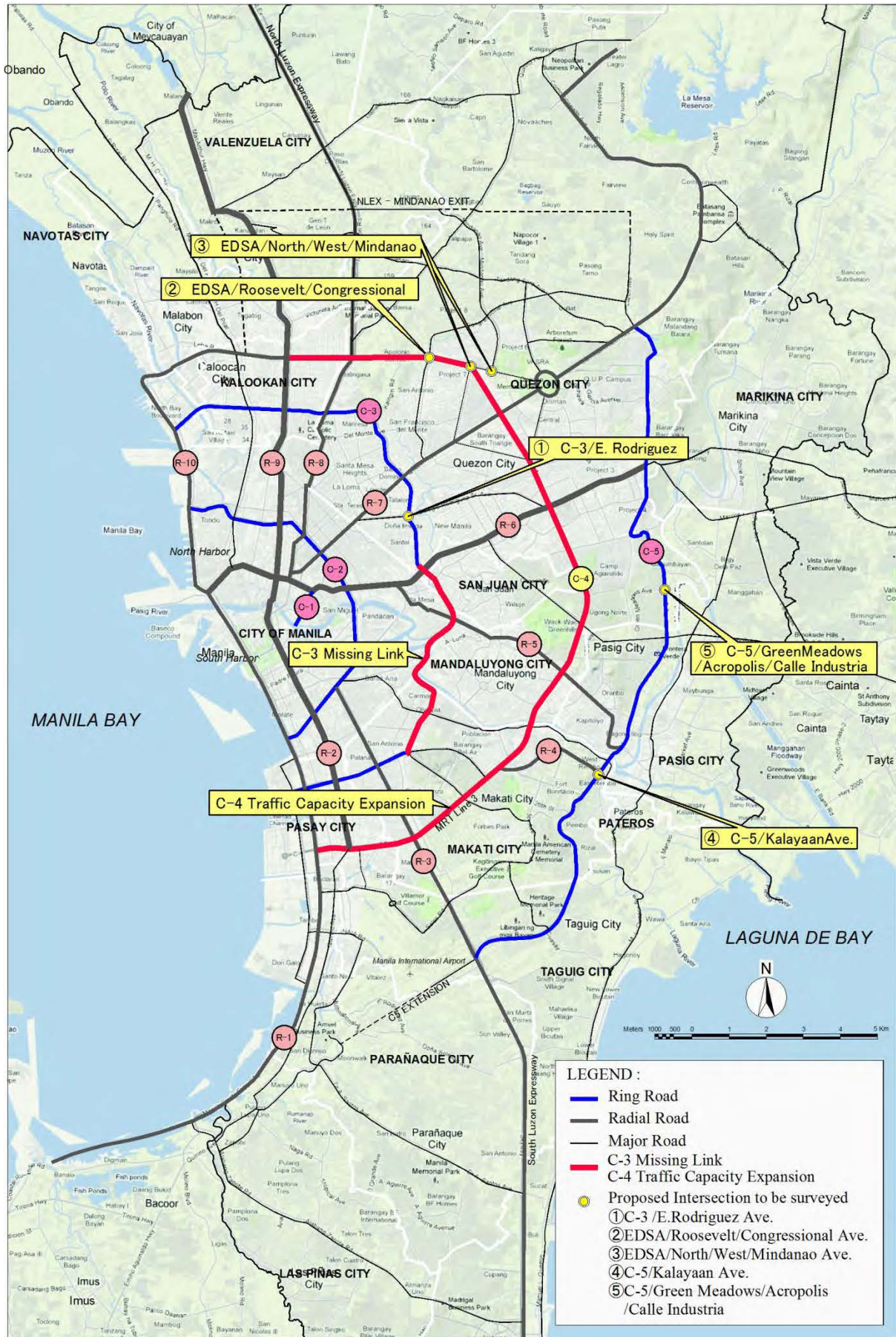

LOCATION MAP

## TABLE OF CONTENTS

### *LOCATION MAP*

### *TABLE OF CONTENTS*

### *LIST OF TABLES AND FIGURES*

### *LIST OF ABBREVIATIONS*

### **EXECUTIVE SUMMARY**

1. INTRODUCTION .....	i
2. CONFIRMATION OF VALIDITY .....	ii
3. TRAFFIC FLOW ANALYSIS AND DEMAND FORECAST.....	iii
4. STUDY OF INTERCHANGE.....	v
5. IMPLEMENTATION SCHEDULE .....	xi
6. EVALUATION OF PROJECT EFFECTIVENESS .....	xv
7. STUDY OF ENVIRONMENTAL AND SOCIAL CONSIDERATIONS .....	xvi
8. C-3 MISSING LINK.....	xviii
9. THE CONCEPTUAL STUDY FOR THE TRAFFIC CAPACITY EXPANSION ALONG EDSA.....	xxii
10. SEMINAR ON LATEST JAPANESE ROAD AND BRIDGE CONSTRUCTION TECHNOLOGY .....	xxv

### **SUMMARY**

#### CHAPTER 1

INTRODUCTION.....	1
1.1 BACKGROUND OF THE PROJECT .....	1
1.2 OBJECTIVE OF THE STUDY .....	1
1.3 STUDY AREA.....	2
1.4 SCOPE OF THE STUDY .....	2
1.5 SCHEDULE OF THE STUDY .....	3

#### CHAPTER 2

CONFIRMATION OF VALIDITY AND NECESSITY OF THE PROJECT.....	4
2.1 TRAFFIC RELATED PROJECTS IN METRO MANILA .....	4
2.2 CONFIRMATION OF CONSISTENCY ON TRAFFIC PLANS BY OTHER AGENCIES .	5
2.3 CONFIRMATION OF NECESSITY AND PRIORITY OF THE PROPOSED FLYOVER	

PROJECT.....	5
2.4 LESSONS LEARNED FROM PREVIOUS SIMILAR PROJECTS AND PROPOSED COUNTERMEASURES .....	5
2.5 CONFIRMATION OF PRESENT CONDITION AND FUTURE INVESTMENT PLAN FOR HIGHWAY SECTOR.....	6
2.6 CONFIRMATION OF ORGANIZATION, ANNUAL BUDGET AND TECHNICAL LEVEL OF THE DPWH MANDATE, FUNCTIONS, VISION AND MISSION.....	6
2.6.1 Authority, Function, Vision and Mission of DPWH .....	6
2.6.2 Annual Budget.....	6
2.6.3 Technical Level for Construction and Maintenance of Flyover of the DPWH .....	6
2.7 CIRCUMSTANCES OF SUPPORT TO THE TRANSPORT SECTOR BY OTHER DONORS .....	7
CHAPTER 3	
TRAFFIC FLOW ANALYSIS AND DEMAND FORECAST .....	8
3.1 TRAFFIC SURVEY .....	8
3.1.1 Type and Location of Traffic Survey .....	8
3.1.2 Result of Intersection Directional Traffic Volume Survey.....	10
3.2 CURRENT TRAFFIC CONDITION OF EACH INTERSECTION .....	14
3.3 TRAFFIC DEMAND FORECAST.....	16
3.3.1 The Methodology of the Demand Forecast .....	16
3.3.2 Result of Traffic Demand Forecast by Micro-simulation.....	17
CHAPTER 4	
STUDY OF EACH INTERCHANGE .....	20
4.1 DESIGN STANDARD FOR HIGHWAY AND FLYOVER .....	20
4.2 C-3/E. RODRIGUEZ AVENUE.....	20
4.2.1 Review of Previous Detailed Design.....	20
4.2.2 Preliminary Design of Interchange.....	21
4.3 EDSA–ROOSEVELT AVENUE/CONGRESSIONAL AVENUE .....	24
4.3.1 Review of Previous Detailed Design.....	24
4.3.2 Preliminary Design of Interchange.....	25
4.4 EDSA / NORTH AVENUE/ WEST AVENUE/ MINDANAO AVENUE .....	27
4.4.1 Review of Previous Detailed Design.....	27
4.4.2 Preliminary Design (EDSA/North/West Interchange) .....	28
4.4.3 Preliminary Design (North/Mindanao Interchange).....	29

4.5	C-5/KALAYAAN AVENUE.....	31	
4.5.1	Review of Previous Detailed Design.....	31	
4.5.2	Advice on Technical Issue and Design Option.....	32	
4.6	C-5–GREEN MEADOWS AVENUE.....	37	
4.6.1	Review of Previous Detailed Design.....	37	
4.6.2	Preliminary Design of Interchange.....	38	
CHAPTER 5			
PREPARATION OF IMPLEMENTATION SCHEDULE.....			40
5.1	STUDY OF CONTRACT PACKAGE ARRANGEMENT.....	40	
5.2	STUDY OF CONSULTANCY SERVICES.....	40	
5.3	PREPARATION OF PROJECT COST INCLUDING RROW COST.....	40	
5.4	PREPARATION OF THE TOTAL IMPLEMENTATION SCHEDULE CONSIDERING THE PERIOD OF ECC AND RAP APPROVAL AND THE PROCESSING IN NEDA ....	42	
5.5	IDEA AND BASIC CONCEPT FOR STEP SCHEME .....	43	
5.5.1	Possibility of Adoption of STEP Scheme.....	43	
5.5.2	Advanced Technology and Know-How of Japanese Firms.....	53	
5.5.3	Outline of STEP Scheme.....	58	
5.5.4	Estimated Cost.....	60	
5.5.5	Draft Estimated Cost for the Consultancy Services for Detailed Engineering Design and Construction Supervision .....	61	
5.5.6	Proposed Implementation Plan (STEP Scheme & General Loan Scheme).....	62	
5.5.7	Proposed Implementation Schedule for Each Interchange.....	63	
5.5.8	Summary of Comparison between STEP Loan and Regular Yen Loan.....	67	
CHAPTER 6			
EVALUATION OF PROJECT EFFECTIVENESS.....			68
6.1	QUANTITATIVE ANALYSIS OF PROJECT EFFECTIVENESS.....	68	
6.1.1	Analytical Methodology.....	68	
6.1.2	Results.....	76	
6.1.3	Sensitivity Analysis.....	79	
6.1.4	Conclusion.....	79	
6.2	EIRR Analysis under STEP Loan Scheme.....	80	
6.2.1	Analytical Methodology.....	80	
6.2.2	Results.....	86	
6.2.3	Sensitivity Analysis.....	90	
6.2.4	Conclusion.....	90	

6.3	QUALITATIVE ANALYSIS OF PROJECT EFFECTIVENESS.....	91	
6.4	OPERATION AND EFFECT INDICATORS .....	91	
6.5	SURVEY ON BENEFIT FOR JAPANESE COMPANIES IN THE PHILIPPINES .....	95	
6.5.1	Purpose of the Survey.....	95	
6.5.2	Survey Method .....	95	
6.5.3	Companies Interviewed .....	95	
6.5.4	Result of Survey .....	95	
6.5.5	Conclusion.....	97	
CHAPTER 7			
STUDY OF ENVIRONMENTAL AND SOCIAL CONSIDERATIONS .....			98
7.1	ENVIRONMENTAL IMPACT ASSESSMENT STUDY .....	98	
7.2	LAND ACQUISITION AND RESETTLEMENT ACTION PLAN (RAP).....	100	
7.3	SUPPORT DPWH TO HOLD PUBLIC CONSULTATION MEETINGS .....	100	
CHAPTER 8			
C-3 MISSING LINK .....			101
8.1	BACKGROUND TO THE STUDY ON THE C-3 MISSING LINK.....	101	
8.2	PROJECT SETTING .....	101	
8.2.1	Administration, Population and Land Use.....	101	
8.2.2	Topography and Geology of Project Area.....	101	
8.2.3	River Systems .....	101	
8.3	ALTERNATIVE ALIGNMENTS AND DPWH COMPARATIVE STUDY.....	102	
8.3.1	Alternative Alignments.....	102	
8.3.2	DPWH Comparative Study.....	104	
8.3.3	Review of DPWH Comparative Study .....	104	
8.4	UPDATED STUDY.....	104	
8.4.1	Geometric Design Standards .....	104	
8.4.2	Typical Sections .....	104	
8.4.3	Scope of Work of Each Alignment.....	105	
8.4.4	Project Affected Buildings and Project Affected People.....	106	
8.4.5	Environmental Issues.....	106	
8.4.6	Rough Cost Estimate .....	106	
8.4.7	Comparative Study .....	107	
8.4.8	Effect on the Project Interchanges due to Construction of the Missing Link.....	109	
8.4.9	Recommendations .....	111	
8.4.10	Related Proposed Projects in Metro Manila .....	111	

CHAPTER 9

THE CONCEPTUAL STUDY FOR THE TRAFFIC CAPACITY EXPANSION ALONG EDSA.. 114

9.1 BACKGROUND OF THE PROJECT ..... 114

9.2 OBJECTIVES AND CONCEPT OF CONCEPTUAL STUDY ..... 114

9.3 CONFIRMATION OF CONSISTENCY BETWEEN THE PROPOSED PROJECT AND PRESENT TRAFFIC PLANS IN THE METRO MANILA ..... 114

9.4 CONFIRMATION OF OPEN SPACES FOR TUNNEL PLAN AND VIADUCT PLAN . 114

9.5 CONFIRMATION OF HINDRANCE STRUCTURES ..... 114

9.6 EDSA GENERAL CONDITION..... 115

9.7 VIADUCT SCHEME..... 116

9.7.1 Proposed Viaduct Plan and Profile ..... 116

9.7.2 Proposed Location of Ramps..... 117

9.7.3 Description of Five High Critical Hindrance Structures/Sections..... 117

9.7.4 Find Space for Proposed Viaduct ..... 119

9.7.5 Cost Estimate..... 119

9.8 TUNNEL SCHEME..... 120

9.8.1 Proposed Plan and Typical Cross Sections of Tunnel ..... 120

9.8.2 Standard Earth Covering of Tunnel..... 121

9.8.3 Ramp (Entrance and Exit) ..... 121

9.8.4 Ventilation System ..... 121

9.8.5 Shield Shaft..... 122

9.8.6 Required Tunnel Facilities..... 123

9.8.7 Construction Schedule..... 123

9.8.8 Cost Estimate..... 125

CHAPTER 10

SEMINAR ON LATEST JAPANESE ROAD AND BRIDGE CONSTRUCTION TECHNOLOGY ....  
..... 127

10.1 OBJECTIVES ..... 127

10.2 SEMINAR PROGRAM ..... 127

10.3 ATTENDANCE ..... 129

10.4 QUESTION AND ANSWER RESULTS ..... 129

10.5 SUMMARY AND ANALYSIS OF QUESTIONNAIRE..... 130

10.6 CONCLUSION..... 130



**LIST OF TABLES**

Table 1.5-1	Study Schedule.....	3
Table 3.1-1	Type and Location of Traffic Surveys .....	8
Table 3.1-2	Intersection Traffic Volume (AADT) (1/3) .....	11
Table 3.1-3	Intersection Traffic Volume (AADT) (2/3) .....	12
Table 3.1-4	Intersection Traffic Volume (AADT) (3/3) .....	13
Table 3.2-1	Summary of Current Condition of Intersections.....	14
Table 3.3-1	Average Traffic Growth Rate for the Project.....	16
Table 3.3-2	Traffic Growth Ratio at Each Intersection .....	17
Table 3.3-3	Daily Vehicle-Km, Vehicle-Hour and Average Travel Speed (C-3/E. Rodriguez Intersection).....	18
Table 3.3-4	Daily Vehicle-km, Vehicle-Hour and Average Travel Speed (EDSA /Roosevelt/ Congressional Intersection).....	18
Table 3.3-5	Daily Vehicle-km, Vehicle-Hour and Average Travel Speed (EDSA /North/West/Mindanao Intersection).....	19
Table 3.3-6	Daily Vehicle-m, Vehicle-Hour and Average Travel Speed (C-5 Green Meadows/Acropolis/Calle Industria) .....	19
Table 4.2-1	Scheme Comparative Table of C-3/E. Rodriguez.....	23
Table 4.3-1	Scheme Comparison Table of EDSA-Roosevelt/Congressional Interchange.....	26
Table 4.4-1	Scheme Comparison Table of EDSA/West/North Interchange .....	29
Table 4.4-2	Scheme Comparison of North Ave./Mindanao Ave. Interchange .....	30
Table 4.5-1	Proposed Options and Findings .....	33
Table 4.5-2	Scheme Comparison Without U-turn Flyover .....	35
Table 4.6-1	Scheme Comparison Table of C-5/Green Meadows/Acropolis/ Calle Industria Interchange .....	39
Table 5.3-1	Summary of Project Cost .....	41
Table 5.3-2	Breakdown of Project Cost .....	41
Table 5.4-1	Draft Implementation Schedule of MMICP .....	42
Table 5.5-1	Implementation Schedule of Original Plan (C-5/Green Meadows).....	44
Table 5.5-2	Implementation Schedule of Steel Box and Slab Type Bridge for C5/Green Meadows Interchange.....	47
Table 5.5-3	Comparison between Original Plan and Steel Box and Slab Type Bridge .....	50
Table 5.5-4	Procurement Amount from Japan for the Project.....	53
Table 5.5-5	Summary of Project Cost (STEP Loan) .....	60
Table 5.5-6	Breakdown of Project Cost (STEP Loan) .....	60
Table 5.5-7	Recapitulation of Draft Estimated Cost for the Consultancy Services for Pre-Construction and Construction Supervision .....	61

Table 5.5-8	Proposed Implementation Plan (STEP Scheme & General Loan Scheme) .....	62
Table 5.5-9	Proposed Implementation Schedule for EDSA/Roosevelt/Congressional.....	63
Table 5.5-10	Proposed Implementation Schedule for EDSA/North/West .....	64
Table 5.5-11	Proposed Implementation Schedule for West/Mindanao .....	66
Table 5.5-12	Proposed Implementation Schedule for C5-Green Meadows/Acropolis/ Calle Industria .....	67
Table 6.1-1	Model Configuration.....	69
Table 6.1-2	Economic Benefit - DPWH BVOC Table (PhP) .....	69
Table 6.1-3	Annual Investment Schedule (%).....	69
Table 6.1-4	Financial and Economic Costs of C-3/E. Rodriguez (PhP million).....	70
Table 6.1-5	Economic Benefit - VOC Saved of C-3/ E. Rodriguez (PhP million, 2018-37)..	70
Table 6.1-6	Financial and Economic Costs of EDSA/Roosevelt/Congressional (PhP million).....	71
Table 6.1-7	Economic Benefit - VOC Saved of EDSA/Roosevelt/Congressional (PhP million, 2018-37).....	71
Table 6.1-8	Financial and Economic Costs of EDSA/North/West (PhP million).....	72
Table 6.1-9	Economic Benefit - VOC Saved of EDSA/North/West (PhP million, 2018-37).	72
Table 6.1-10	Financial and Economic Costs of North/Mindanao (PhP million).....	73
Table 6.1-11	Economic Benefit - VOC Saved of North/Mindanao (PhP million, 2018-37) ....	73
Table 6.1-12	Financial and Economic Costs of C-5/Green Meadows (PhP million).....	74
Table 6.1-13	Economic Benefit - VOC Saved of C-5/Green Meadows (PhP million, 2018-37).....	74
Table 6.1-14	Financial and Economic Costs: Aggregate (PhP million).....	75
Table 6.1-15	Economic Benefit - VOC Saved (PhP million, 2018-37) .....	75
Table 6.1-16	EIRR and ENPV by Intersection.....	76
Table 6.1-17	Sensitivity Analysis.....	79
Table 6.1-18	EIRR and Attributes of Scarce Resource (2018-37) .....	80
Table 6.2-1	Model Configuration (STEP Loan).....	81
Table 6.2-2	Annual Investment Schedule (%).....	81
Table 6.2-3	Financial and Economic Costs of EDSA/Roosevelt/Congressional (STEP Loan, PhP million) .....	82
Table 6.2-4	Economic Benefit - VOC Saved of EDSA/Roosevelt/Congressional (STEP Loan, PhP million, 2018-37) .....	82
Table 6.2-5	Financial and Economic Costs of EDSA/North/West (PhP million).....	83
Table 6.2-6	Economic Benefit - VOC Saved of EDSA/North/West (STEP Loan, PhP million, 2018-37) .....	83
Table 6.2-7	Financial and Economic Costs of North/Mindanao (PhP million).....	84

Table 6.2-8	Economic Benefit - VOC Saved of North/Mindanao (STEP Loan, PhP million, 2018-37) .....	84
Table 6.2-9	Financial and Economic Costs of C-5/Green Meadows (STEP Loan, PhP million) .....	85
Table 6.2-10	Economic Benefit - VOC Saved of C-5/Green Meadows (STEP Loan, PhP million) .....	85
Table 6.2-11	Financial and Economic Costs (STEP Loan, PhP million).....	86
Table 6.2-12	Economic Benefit - VOC Saved (STEP Loan, PhP million, 2018-37).....	86
Table 6.2-13	EIRR and ENPV by Intersection (STEP Loan) .....	87
Table 6.2-14	Sensitivity Analysis (STEP Loan) .....	90
Table 6.4-1	Monitoring Plan Operation and Effect Indicators .....	92
Table 6.5-1	Japanese Affiliated Firms Selected for Interview Survey .....	96
Table 6.5-2	Summary of Findings from Interviews to Japanese Firms.....	97
Table 7.1-1	Results of Scoping - Adverse Environmental Impacts Land Acquisition.....	98
Table 7.2-1	Land Acquisition, Involuntary Resettlement and Affected Structure for MMICP.....	100
Table 8.4-1	Scope of Work of the Alternative Alignments, C-3 Missing Link .....	105
Table 8.4-2	Cost Estimate .....	107
Table 8.4-3	Comparative Study of the Alternative Alignment, C-3 Missing Link .....	108
Table 9.7-1	Summary of Estimated Project Cost .....	120
Table 9.8-1	Rough Estimated Construction Schedule.....	124
Table 9.8-2	Summary of Rough Estimate Cost of Each Schemes .....	126

**LIST OF FIGURES**

Figure 3.1-1	Traffic Survey Location at C-3/E. Rodriguez Intersection .....	8
Figure 3.1-2	Traffic Survey Location at EDSA/Roosevelt/Congressional Ave. ....	9
Figure 3.1-3	Traffic Survey Location at EDSA/North/West/Mindanao Ave. ....	9
Figure 3.1-4	Traffic Survey Location at C-5/Kalayaan Ave. ....	10
Figure 3.1-5	Traffic Survey Location at C-5/Green Meadows.....	10
Figure 4.5-1	Summarized Intersection Flow Graphic Summary (AADT) .....	33
Figure 4.5-2	Traffic Flow by Schemes .....	35
Figure 5.5-1	Special Type of Frame Support.....	44
Figure 5.5-2	General View of Steel Box and Slab Type Bridge.....	46
Figure 5.5-3	Elevation Plan (1/2) .....	48
Figure 5.5-4	Elevation Plan (2/2) .....	49
Figure 5.5-5	Investigation Report.....	52
Figure 6.1-1	Economic Benefits by Value of C-3/E. Rodriguez (2018-2037) .....	70
Figure 6.1-2	Economic Benefits by Value of EDSA/Roosevelt/Congressional (2018-2037)..	71
Figure 6.1-3	Economic Benefits by Value of EDSA/North/West (2018-2037) .....	72
Figure 6.1-4	Economic Benefits by Value of North/Mindanao (2018-2037).....	73
Figure 6.1-5	Economic Benefits by Value of C-5/Green Meadows (2018-2037) .....	74
Figure 6.1-6	Economic Benefits by Value (2018-2037).....	75
Figure 6.1-7	Cost and Benefit Streams, and EIRR (C-3/E. Rodriguez) .....	76
Figure 6.1-8	Economic Cost and Benefit Streams, and EIRR (EDSA/Roosevelt/Congressional).....	77
Figure 6.1-9	Economic Cost and Export Parity Benefit, and EIRR (EDSA/North/West/Mindanao).....	77
Figure 6.1-10	Economic Cost and Export Parity Benefit, and EIRR (North/Mindanao) .....	78
Figure 6.1-11	Economic Cost and Benefit Streams, and EIRR (C-5/Green Meadows).....	78
Figure 6.1-12	Cost and Benefit Streams and EIRR .....	79
Figure 6.2-1	Economic Benefits by Value of EDSA/Roosevelt/Congressional (STEP Loan, 2018-2037) .....	82
Figure 6.2-2	Economic Benefits by Value of EDSA/North/West (2018-2037) .....	83
Figure 6.2-3	Economic Benefits by Value of North/Mindanao (2018-2037).....	84
Figure 6.2-4	Economic Benefits by Value of C-5/Green Meadows .....	85
Figure 6.2-5	Economic Benefits by Value (STEP Loan, 2018-2037) .....	86
Figure 6.2-6	Economic Cost and Benefit Streams, and EIRR (EDSA/Roosevelt/Congressional, STEP Loan).....	87
Figure 6.2-7	Economic Cost and Export Parity Benefit, and EIRR (EDSA/North/West, STEP Loan) .....	88

Figure 6.2-8	Economic Cost and Export Parity Benefit, and EIRR (North/ Mindanao, STEP Loan).....	88
Figure 6.2-9	Economic Cost and Benefit Streams, and EIRR (C-5/Green Meadows, STEP Loan) .....	89
Figure 6.2-10	Cost and Benefit Streams, and EIRR (STEP Loan).....	90
Figure 6.4-1	Monitoring Location for Traffic Volume Count and Travel Speed (EDSA/ Roosevelt/Congressional Ave. Intersection: Along EDSA – Cubao Side).....	93
Figure 6.4-2	Monitoring Location for Traffic Volume Count and Travel Speed (EDSA/North Ave./West Ave. Intersection: Along EDSA – Cubao Side).....	93
Figure 6.4-3	Monitoring Location for Traffic Volume Count and Travel Speed (North Ave. /Mindanao Ave. Intersection: Along North Avenue – EDSA/SM Side) .. .....	94
Figure 6.4-4	Monitoring Location for Traffic Volume Count and Travel Speed (C-5/Green Meadows/Acropolis/Galle Industria – Pasig City Side).....	94
Figure 8.3-1	Alternative Alignments – DPWH Study .....	103
Figure 8.4-1	Effect on Traffic Volume for the Project Interchanges due to Construction of the C-3 Missing Link .....	110
Figure 8.4-2	Related Projects in Metro Manila .....	113
Figure 9.5-1	Locations of Flyover/Underpass and MRT/LRT STATIONS .....	115
Figure 9.7-1	Steel Viaduct Piers .....	117
Figure 9.7-2	Location of the Five Most Difficult Construction Site .....	118
Figure 9.8-1	Typical Tunnel Section of 3-Types Tunnel .....	120
Figure 9.8-2	Tunnel Layout (Plan and Profile).....	121
Figure 9.8-3	General Concept of Ventilation System.....	122
Figure 9.8-4	General Concept of Vertical Shaft .....	123

**LIST OF ABBREVIATIONS**

AADT	:	Annual Average Daily Traffic
AASHTO	:	American Association of State Highway and Transportation Officials
ADB	:	Asian Development Bank
AP	:	Affected Person
ASEP	:	Association of Structural Engineers of the Philippines
ARPA	:	Abbreviated Resettlement Action Plan
BOD	:	Biological Oxygen Demand
BOM	:	Bureau of Maintenance
BOT	:	Build Operate Transfer
BRT	:	Build Rapid Transit
BTMC	:	Basic Technology and Management Corporation
C-3	:	Circumferential Road-3
C-4	:	Circumferential Road-4 (EDSA)
C-5	:	Circumferential Road-5
CBD	:	Central Business District
CDO	:	Cease and Desist Order
CER	:	Compliance Evaluation Report
CMMTC	:	Citra Metro Manila Tollways Corporation.
CMR	:	Compliance Monitoring Report
CMVR	:	Compliance Monitoring and Validation Report
CNC	:	Certificate of Non-Coverage
CS	:	Construction Supervision
DD	:	Detailed Design
DE	:	Design Engineer
DENR	:	Department of Environment and Natural Resources
DFR	:	Final Report
DO	:	Dissolved Oxygen
DOH	:	Department of Health
DOTC	:	Department of Transportation and Communication
DPWH	:	Department of Public Works and Highways
DWT	:	Dead Weight Tonnage
ECAs	:	Environmentally Critical Areas
ECC	:	Environmental Compliance Certificate
ECPs	:	Environmentally Critical Projects
EDSA	:	Epifanio Delos Santos Avenue (C-3)
EIA	:	Environmental Impact Assessment

EIS	:	Environmental Impact Statement
EIRR	:	Economic Internal Rate of Return
EMA	:	External Monitoring Agent
EMB	:	Environmental Management Bureau
EMK	:	Equivalent Maintenance Kilometer
EMP	:	Environmental Management Plan
ENPV	:	Economy Net Present Value
ESSO	:	Environmental and Social Services Office
FTI	:	Food Terminal Inc.
GAA	:	General Appropriations Act
GDP	:	Gross Domestic Product
GOP	:	Government of Philippines
HIV/AIDS	:	Human Immunodeficiency Virus/Acquired Immune Deficiency Syndrome
ICC	:	Indigenous Cultural Community
IEC	:	Information, Education and Communication
IEE	:	Initial Environmental Examination
IEER	:	Initial Environmental Examination Report
IEEC	:	Initial Environmental Examination Checklist
IMA	:	Internal Monitoring Agent
IMP	:	Impacts Management Plan
IP	:	Indigenous People
IPAP	:	Indigenous People's Action Plan
IPRA	:	Indigenous Peoples' Rights Act
IRA	:	Independent Land Appraiser
IROW	:	Infrastructure Right of Way
IUCN	:	International Union for the Conservation of Nature and Natural Resources
JBIC	:	Japanese Bank International for Cooperation
JICA	:	Japan International Cooperation Agency
KEDCF	:	Korean Economic Development Cooperation Fund.
KOICA	:	Korea International Cooperation Agency
LAPRAP	:	Land Acquisition Plan and Resettlement Action Plan
LARRIPP	:	Land Acquisition, Resettlement, Rehabilitation and Indigenous Peoples' Policy
LGU	:	Local Government Unit
LRT	:	Light Rail Transit
MARIPAS	:	Marikina, Rizal, Pasig
MBA	:	Maintenance Work by Administration

MBC	:	Maintenance Work by Contract
MCC	:	Millennium Challenge Corporation
MMDA	:	Metro Manila Development Authority
MMICP	:	Metro Manila Interchange Project (VI)
MMT	:	Multi-partite Monitoring Team
MMPIBAS	:	Mega Manila Provincial Integrated Bus Axis System
MMURTRIP	:	Metro Manila Urban Transport Integration Project
MMUTIS	:	Metro Manila Urban Transport Integration Study
MNTC	:	Metro Manila Tollway Corporation
MOOE	:	Maintenance and Other Operating Expenses
MRIC	:	Municipal/City Resettlement Implementation Committee
MRT	:	Mass Rail Transit
MVUC	:	Motor Vehicle User Charge
MWSS	:	Metropolitan Waterworks and Sewerage System
NAIA	:	Ninoy Aquino International Airport
NBP	:	New Bilibid Prison
NCR	:	National Capital Region
NCIP	:	National Commission on Indigenous Peoples
NECA	:	Non-Environmentally Critical Areas
NECP	:	Non-Environmentally Critical Project
NEDA	:	National Economic Development Authority
NEPC	:	National Environmental Protection Council
NHA	:	National Housing Authority
NIPAS	:	National Integrated Projected Areas System
NLEX	:	North Luzon Expressway
NPCC	:	National Pollution Control Commission
NSO	:	National Statistics Office
OBR	:	Organized Bus Route
ODA	:	Official Development Assistance
OD	:	Origin Destination
OECF	:	Overseas Economic Cooperation Fund
PAF	:	Project Affected Family
PAPs	:	Project Affected Persons
PCU	:	Passenger Car Units
PDR	:	Project Description Report
PEISS	:	Philippine Environmental Impact Statement System
PERT/CPM	:	Program Evaluation Review Technique/Critical Path Method
PMO	:	Project Management Office



PNCC	:	Philippine National Construction Corporation
PNR	:	Philippine National Railways
PPP	:	Public-Private Partnership
PROC	:	People's Republic of China
PRRC	:	Pasig River Rehabilitation Commission
PRRP	:	Pasig River Rehabilitation Programs
PUB	:	Public Utility Bus
PUV	:	Public Utility Vehicle
QMC	:	Quezon Memorial Circle
RA	:	Republic Act
RAP	:	Resettlement Action Plan
RIC	:	Resettlement Implementation Committee
ROW	:	Right of Way
SC	:	Supervising Consultant
SLEX	:	South Luzon Expressway
SMC	:	San Miguel Corporation
SMR	:	Self-Monitoring Report
SPM	:	Suspended Particulate Matter
STRADA	:	System for Traffic Demand Analysis
URPO	:	Urban Roads and Project Office
UV	:	Utility Vehicle
UVVRS	:	Uniform Vehicular Volume Reduction Scheme
UWRS	:	Uniform Volume Reduction Scheme
WB	:	World Bank

## EXECUTIVE SUMMARY

### 1. INTRODUCTION

#### 1.1 Background of the Project

Metro Manila has a strategic foothold in the socio-economic activities of the Philippines that attracts 13% of the population and generates 37% of the total GDP of the country. Metro Manila has been continuously developing and improving its transport sector infrastructure and traffic network. Manila is currently still faced with the problems of heavy traffic congestion and increased travel times. Such a situation creates a bottleneck for the distribution of goods and hampers the movement of people, resulting in huge economic losses. At the same time, chronic traffic congestion causes increase in air pollution and noise.

In view of the above, the DPWH has requested the JICA to evaluate the possibility of financing the construction of the highly prioritized grade separated interchange projects in Metro Manila. JICA responded favorably to this DPWH request and has selected the consultants to undertake the Preparatory Survey for Metro Manila Interchange Construction Project (VI).

#### 1.2 Objectives of the Study

- (1) The objective of the Study is to conduct screening of the proposed improvements as Japanese ODA Loan Project, focusing on the items such as the purpose of the project, scope of works, project cost, project implementation organization, operation and maintenance organization and social environmental aspects based

on previous detailed design and other related studies.

- (2) Conduct a review and study for the preliminary engineering study on the construction of the Circumferential Road-3 (C-3) missing link includes of impact to the proposed flyover.
- (3) Conduct preliminary engineering study on traffic capacity expansion of Circumferential Road-4 (C-4) includes of find space for proposed viaduct structures.

#### 1.3 Scope of the Study

- (1) **Study of construction of interchanges**
  - Feasibility Study for four (4) interchanges
    - C-3/E. Rodriguez
    - EDSA/Roosevelt/Congressional
    - EDSA/North/West/Mindanao
    - C-5/Green Meadows/  
Calle Industria/Eastwood
  - Scheme study and preparation of design options for C-5/Kalayaan
- (2) **Study of the C-3 missing link includes of impact to the proposed flyover.**
  - Review of six (6) alignments established by DPWH
  - Establish evaluation criteria and undertake evaluation of alternative alignments
- (3) **Study on C-4 traffic capacity expansion includes of find space for proposed viaduct structures.**
  - Review of present and proposed projects in the study area
  - Study on traffic capacity expansion for the construction of viaduct and tunnel schemes.

## **2. CONFIRMATION OF VALIDITY AND NECESSITY OF THE PROJECT**

### **2.1 Confirmation of Consistency on Traffic Plans by Other Agencies**

This Project is consistent with the traffic plans of other agencies such as MMDA and DOTC. There is no conflict with the traffic plans of other agencies; it is supportive of the traffic plans of the LGUs and other agencies. However, the following issues need to be noted:

#### **MRT Line 7 Construction**

The proposed intersection scheme for EDSA/West/North/Mindanao Avenues has been confirmed and approved by the project proponent of MRT 7 and DOTC. However, a reconfirmation has to be made during the Detailed Design Stage to ensure that there has been no change in the scheme that has been originally approved.

#### **Skyway Stage 3**

The project is a 14.5km six-lane elevated viaduct that will connect the north and south expressways via C-3, and has been approved as a priority project by the government last August 2012. Correspondingly, implementation of the C-3/E. Rodriguez Interchange has been deferred by DPWH due to a conflict of its alignment with that of the project.

### **2.2 Confirmation of Necessity and Priority of the Proposed Flyover Project**

The five interchange under this proposal are included in the list of priority projects for NCR under DPWH's Public Investment Plan 2011-2016. Proposed budget for the Metro Manila Interchange Construction Project is about P7.36 Billion. The construction of five interchanges has a total allocation of P5.17

Billion excluding consultancy services.

### **2.3 Lessons Learned from Previous Similar Projects and Proposed Countermeasures**

The ex-post evaluation study for Metro Manila Interchange Construction Project (IV) dated June 2008 was undertaken jointly by JBIC Consultants and the National Economic and Development Authority (NEDA). The Report identified the following three lessons and the recommended actions that need to be taken into account in future project implementation:

- Lesson-1: Lack of in-depth investigation during detailed design
- Lesson-2: Delay in land acquisition and resettlement
- Lesson-3: Absence of pragmatic project scheduling
- Recommendation: Sufficient maintenance funds should be secured

The Consolidated Report in January 2011 for the Metro Manila Urban Transport Integration Project (MMURTRIP) financed by World Bank identified that bureaucratic processes, changes in administration, and ensuing changes in development policies are the main causes of delay in project implementation.

### **2.4 Technical Level for Construction and Maintenance of Flyover of the DPWH**

The PMO-URPO is in charge of flyover construction and its maintenance is undertaken by NCR Regional Office. Technical level of both agencies is fairly high and capable enough to construct and maintain flyovers, but there is some room for improvement in the following processes:

1. Bureaucratic procurement process
2. Prolonged relocation process
3. Casual maintenance approach rather than preventive

### 3. TRAFFIC FLOW ANALYSIS AND DEMAND FORECAST

#### 3.1 Traffic Survey

The traffic surveys shown in **Table 3-1** were conducted to grasp the present traffic flow characteristics of the project sites.

**Table 3-1 Type and Location of Traffic Surveys**

Type of Survey	Purpose of the Survey	Location
1. Intersection Directional Traffic Volume (Dec. 6~Dec. 21 2011)	- Assessment of present service level of the intersections - Formulation of interchange schemes - Benefit calculation	1. C-3/E. Rodriguez 2. EDSA/Roosevelt/Congressional 3. EDSA/North/West/Mindanao 4. C-5/Kalayaan 5. C-5/Green Meadows/Acroplis /Calle Industria
2. Number Plate Vehicle Movement Survey (Dec. 6~Dec. 21 2011)	- Formulation of present Origin Destination (OD) matrix for traffic analyses	Note: C-5/Kalayaan is not included in the Number Plate Survey
3. Intersection Queue Length Survey (Dec. 6~Dec. 21 2011)	- Verification of current service level of the intersections	
4. Travel Speed Survey (Nov. 22~Dec.8 2011)	- Basic information for assessment of effect and impact of interchange construction	8 major streets passing/crossing project intersections

Source: JICA Study Team

Note: Survey of above 1, 2 and 3 of C-5/Kalayaan was conducted March 13 and 14 2012

#### 3.1.1 Result of Traffic Demand Forecast by Micro-simulation

Daily vehicle-km, daily-vehicle hour and average travel speed of each interchange are shown in **Tables 3-2 to 3-5**.

**Table 3-2 Daily Vehicle-Km, Vehicle-Hour and Average Travel Speed (C-3/E. Rodriguez Intersection)**

Indicator	Vehicle Category	2011 (Daily)	2018 (Daily)			2028 (Daily)		
			2018 (With)	2018 (Without)	With - Without	2028 (With)	2028 (Without)	With - Without
Vehicle Km	Car	90,049	174,597	175,989	-1,392	111,650	112,375	-724
	Jeepney	9,346	18,453	18,432	20	30,503	30,529	-26
	UtilityVehicle	9,618	18,353	18,574	-222	11,950	12,071	-121
	Bus	449	836	805	32	559	536	23
	Truck	2,881	5,531	5,624	-93	3,517	3,541	-23
	Motorcycle	41,595	86,428	81,010	5,418	139,866	130,296	9,570
	<b>Total</b>	<b>153,938</b>	<b>304,197</b>	<b>300,433</b>	<b>3,764</b>	<b>298,046</b>	<b>289,347</b>	<b>8,699</b>
Vehicle Hour	Car	3,293	5,842	7,326	-1,483	3,627	4,603	-977
	Jeepney	340	610	767	-158	985	1,190	-205
	UtilityVehicle	356	605	778	-173	382	511	-129
	Bus	16	27	34	-6	18	21	-3
	Truck	106	164	230	-67	101	143	-42
	Motorcycle	1,518	2,541	3,270	-730	4,050	5,900	-1,850
	<b>Total</b>	<b>5,629</b>	<b>9,788</b>	<b>12,405</b>	<b>-2,617</b>	<b>9,162</b>	<b>12,369</b>	<b>-3,206</b>
Traffic Volume	Car	67,712	132,486	132,376	111	84,621	84,692	-71
	Jeepney	7,379	14,518	14,529	-11	23,964	24,062	-98
	UtilityVehicle	6,917	13,393	13,417	-24	8,687	8,717	-30
	Bus	352	632	628	4	421	421	0
	Truck	2,001	3,890	3,903	-14	2,460	2,443	16
	Motorcycle	28,668	55,779	55,808	-28	90,305	89,762	542
	<b>Total</b>	<b>113,029</b>	<b>220,698</b>	<b>220,660</b>	<b>38</b>	<b>210,458</b>	<b>210,098</b>	<b>360</b>
Average Travel Speed (Km/Hour)	Car	27.3	29.9	24.0	5.9	30.8	24.4	6.4
	Jeepney	27.5	30.3	24.0	6.2	31.0	25.6	5.3
	UtilityVehicle	27.0	30.4	23.9	6.5	31.3	23.6	7.7
	Bus	27.5	30.8	24.0	6.9	31.9	25.7	6.2
	Truck	27.2	33.8	24.4	9.4	34.8	24.7	10.1
	Motorcycle	27.4	34.0	24.8	9.2	34.5	22.1	12.4
	<b>Average</b>	<b>27.3</b>	<b>31.1</b>	<b>24.2</b>	<b>6.9</b>	<b>32.5</b>	<b>23.4</b>	<b>9.1</b>

Source: JICA Study Team

**Table 3-3 Daily Vehicle-km, Vehicle-Hour and Average Travel Speed (EDSA /Roosevelt/ Congressional Intersection)**

Indicator	Vehicle Category	2011 (Daily)	2018 (Daily)			2028 (Daily)		
			2018 (With)	2018 (Without)	With - Without	2028 (With)	2028 (Without)	With - Without
Vehicle Km	Car	118,775	144,485	150,012	-5,527	134,665	139,990	-5,325
	Jeepney	20,782	22,329	26,650	-4,321	29,268	35,042	-5,774
	Utility Vehicle	18,410	22,402	23,286	-884	20,734	21,591	-857
	Bus	15,196	18,316	19,392	-1,076	16,966	17,962	-996
	Truck	14,081	17,072	17,669	-597	15,885	16,530	-646
	Motorcycle	21,078	25,264	26,579	-1,315	32,937	34,900	-1,963
	<b>Total</b>	<b>208,323</b>	<b>249,869</b>	<b>263,588</b>	<b>-13,720</b>	<b>250,454</b>	<b>266,016</b>	<b>-15,561</b>
Vehicle Hour	Car	3,915	4,770	5,116	-347	4,444	4,810	-366
	Jeepney	710	703	945	-242	926	1,252	-326
	Utility Vehicle	610	749	799	-50	691	743	-51
	Bus	510	543	675	-132	503	629	-127
	Truck	469	569	612	-43	527	577	-50
	Motorcycle	701	904	916	-12	1,183	1,210	-27
	<b>Total</b>	<b>6,914</b>	<b>8,237</b>	<b>9,063</b>	<b>-826</b>	<b>8,274</b>	<b>9,221</b>	<b>-947</b>
Traffic Volume	Car	78,477	99,454	99,193	261	92,615	92,521	94
	Jeepney	9,664	12,419	12,338	82	16,302	16,266	37
	Utility Vehicle	11,131	14,190	14,178	12	13,159	13,182	-24
	Bus	10,550	13,480	13,427	53	12,468	12,475	-7
	Truck	8,484	10,934	10,997	-63	10,148	10,266	-118
	Motorcycle	13,641	17,250	17,239	10	22,662	22,662	0
	<b>Total</b>	<b>131,948</b>	<b>167,726</b>	<b>167,372</b>	<b>355</b>	<b>167,353</b>	<b>167,372</b>	<b>-18</b>
Average Travel Speed (Km/Hour)	Car	30.3	30.3	29.3	1.0	30.3	29.1	1.2
	Jeepney	29.3	31.8	28.2	3.6	31.6	28.0	3.6
	Utility Vehicle	30.2	29.9	29.2	0.8	30.0	29.1	0.9
	Bus	29.8	33.7	28.7	5.0	33.8	28.5	5.2
	Truck	30.0	30.0	28.9	1.2	30.2	28.7	1.5
	Motorcycle	30.1	27.9	29.0	-1.1	27.8	28.8	-1.0
	<b>Average</b>	<b>30.1</b>	<b>30.3</b>	<b>29.1</b>	<b>1.3</b>	<b>30.3</b>	<b>28.8</b>	<b>1.4</b>

Source: JICA Study Team

**Table 3-4 Daily Vehicle-km, Vehicle-Hour and Average Travel Speed (EDSA /North/West/Mindanao Intersection)**

Indicator	Vehicle Category	2011 Daily	2018 (Daily)			2028 (Daily)		
			2018 (With)	2018 (Without)	With - Without	2028 (With)	2028 (Without)	With - Without
Vehicle Km	Car	257,061	308,345	317,028	-8,683	289,377	297,381	-8,004
	Jeepney	22,322	23,009	26,265	-3,256	27,499	31,912	-4,413
	Utility Vehicle	26,357	30,795	32,449	-1,654	28,887	30,528	-1,641
	Bus	14,382	18,139	18,292	-154	16,835	16,960	-125
	Truck	23,232	28,545	29,065	-520	26,755	27,198	-443
	Motorcycle	40,702	50,013	50,930	-917	65,028	66,657	-1,629
	<b>Total</b>	<b>384,056</b>	<b>458,845</b>	<b>474,029</b>	<b>-15,184</b>	<b>454,382</b>	<b>470,635</b>	<b>-16,254</b>
Vehicle Hour	Car	9,191	10,754	13,360	-2,606	9,753	12,072	-2,319
	Jeepney	834	939	1,079	-141	1,114	1,293	-179
	Utility Vehicle	972	1,135	1,377	-242	1,030	1,284	-254
	Bus	460	506	636	-130	466	567	-102
	Truck	895	1,015	1,349	-334	919	1,223	-303
	Motorcycle	1,544	1,723	2,603	-880	2,198	3,293	-1,095
	<b>Total</b>	<b>13,895</b>	<b>16,072</b>	<b>20,405</b>	<b>-4,332</b>	<b>15,481</b>	<b>19,732</b>	<b>-4,252</b>
Traffic Volume	Car	167,998	206,255	205,934	321	193,438	193,023	415
	Jeepney	10,459	11,455	11,489	-34	12,837	12,828	8
	Utility Vehicle	16,403	19,929	19,937	-9	18,690	18,755	-65
	Bus	10,381	13,198	13,194	4	12,242	12,246	-4
	Truck	16,154	20,309	20,233	77	18,959	18,945	14
	Motorcycle	26,130	32,745	32,588	156	42,425	42,358	67
	<b>Total</b>	<b>247,526</b>	<b>303,890</b>	<b>303,375.1</b>	<b>515.0</b>	<b>298,592</b>	<b>298,156</b>	<b>436</b>
Average Travel Speed (Km/Hour)	Car	28.0	28.7	23.7	4.9	29.7	24.6	5.0
	Jeepney	26.8	24.5	24.3	0.2	24.7	24.7	0.0
	Utility Vehicle	27.1	27.1	23.6	3.6	28.1	23.8	4.3
	Bus	31.3	35.8	28.7	7.1	36.2	29.9	6.3
	Truck	26.0	28.1	21.5	6.6	29.1	22.2	6.9
	Motorcycle	26.4	29.0	19.6	9.5	29.6	20.2	9.3
	<b>Total</b>	<b>27.6</b>	<b>28.5</b>	<b>23.2</b>	<b>5.3</b>	<b>29.4</b>	<b>23.9</b>	<b>5.5</b>

Source: JICA Study Team

**Table 3-5 Daily Vehicle-m, Vehicle-Hour and Average Travel Speed (C-5 Green Meadows/Acropolis/Calle Industria)**

Indicator	Vehicle Category	2011 (Daily)	2018 (Daily)			2028 (Daily)		
			2018 (With)	2018 (Without)	With - Without	2028 (With)	2028 (Without)	With - Without
Vehicle Km	Car	324,251	367,398	373,519	-6,121	543,481	552,795	-9,314
	Jeepney	13,173	15,185	15,213	-28	22,715	22,867	-152
	Utility/Vehicle	54,476	62,176	62,507	-331	92,139	92,672	-533
	Bus	772	858	865	-8	1,302	1,299	2
	Truck	34,601	39,742	39,905	-163	58,850	59,115	-265
	Motorcycle	90,496	103,721	104,143	-423	152,917	153,418	-501
	<b>Total</b>	<b>517,769</b>	<b>589,078</b>	<b>596,153</b>	<b>-7,074</b>	<b>871,404</b>	<b>882,166</b>	<b>-10,763</b>
Vehicle Hour	Car	10,309	10,885	11,936	-1,051	17,874	19,823	-1,949
	Jeepney	419	419	487	-67	702	854	-153
	Utility/Vehicle	1,736	1,783	2,003	-220	2,971	3,531	-560
	Bus	25	23	28	-4	39	48	-8
	Truck	1,102	1,108	1,278	-170	1,822	2,182	-360
	Motorcycle	2,878	3,008	3,329	-321	4,928	5,534	-606
	<b>Total</b>	<b>16,468</b>	<b>17,227</b>	<b>19,061</b>	<b>-1,834</b>	<b>28,336</b>	<b>31,972</b>	<b>-3,635</b>
Traffic Volume	Car	114,767	132,136	132,178	-42	195,412	195,166	246
	Jeepney	4,360	5,054	5,051	3	7,574	7,591	-17
	Utility/Vehicle	18,281	20,971	20,974	-3	30,992	30,992	0
	Bus	257	288	288	0	428	428	0
	Truck	11,526	13,255	13,286	-31	19,582	19,606	-24
	Motorcycle	30,917	35,590	35,667	-77	52,532	52,401	132
	<b>Total</b>	<b>180,108</b>	<b>207,294</b>	<b>207,444</b>	<b>-151</b>	<b>306,520</b>	<b>306,183</b>	<b>337</b>
Average Travel Speed (Km/Hour)	Car	31.5	33.8	31.3	2.5	30.4	27.9	2.5
	Jeepney	31.4	36.2	31.3	4.9	32.4	26.8	5.6
	Utility/Vehicle	31.4	34.9	31.2	3.7	31.0	26.2	4.8
	Bus	31.5	36.7	31.2	5.5	33.2	27.3	5.9
	Truck	31.4	35.9	31.2	4.7	32.3	27.1	5.2
	Motorcycle	31.4	34.5	31.3	3.2	31.0	27.7	3.3
	<b>Total</b>	<b>31.4</b>	<b>34.2</b>	<b>31.3</b>	<b>2.9</b>	<b>30.8</b>	<b>27.6</b>	<b>3.2</b>

Source: JICA Study Team

#### 4. STUDY OF EACH INTERCHANGE

##### 4.1 Design Standard for Highway and Flyover

Design standards for Highway and Flyovers adopt DPWH design standards except for seismic acceleration coefficient which was increased from 0.4g to 0.5g due to scheduled change in the ASEP design code.

##### 4.2 C-3/E. Rodriguez Avenue

###### 4.2.1 Review of Previous Detailed Design

###### Along C-3

The total length of the project section along this road segment is 2,105m, consisting of 275m of 4-lanes flyover, 205m of approach roads and 1,625m of embankment roads. The highest embankment height is 2.50m.

###### Along E. Rodriguez Avenue

The road has 827m long and four lanes with a total width of 20.0m and highest embankment height of 1.55m.

###### Identified Problems

There has been no study yet of the possible impacts of flooding on the people living within the vicinity of the project area and also no documents showing public acceptance on the proposed raising of the current road elevation.

###### Recommendations

The most appropriate countermeasure(s) against flood, i.e. in case to raise present road elevations further, etc. should be thoroughly studied.

###### 4.2.2 Preliminary Design of Interchange

###### (1) Study and Countermeasure against Flood

The construction of an elevated highway should

be provided proper counter measure to the fundamental problem of floods and should be properly addressed by a flood control management project.

### **(2) Comparative Study**

The following three (3) alternatives are proposed as the most suitable schemes for comparison:

Scheme-1 : 275.0m long flyover and 630m long 6 lanes additional approach road (Original Design).

Scheme-2 : 280.0m long flyover

Scheme-3 : 280.0m long flyover and 598m long 4 lanes additional approach with RCBC.

Among the three (3) schemes, scheme-3 was selected though it was more expensive than scheme-2 by approximately 22%. This is due to the 598m extent of elevated road to alleviate effects of flood and provide 2-lanes per direction of service roads at the at-grade section which will be deemed sufficient to support the activities of people along this road section.

Implementation of the C-3/E. Rodriguez Interchange was cancelled by the DPWH to give priority to the construction of Skyway Stage 3, second level, along C-3 under BOT scheme.

### **(3) Cost Estimate and Construction Duration**

Estimated cost and construction duration are PhP XXX M and 17 months, respectively.

## **4.3 EDSA-Roosevelt Ave. / Congressional Avenue**

### **4.3.1 Review of Previous Detailed Design**

#### Northbound

The total length of the project section and the

flyover are 729m and 502m, respectively.

#### Southbound

Total length of the project section and flyover are 729m and 500m, respectively.

#### Identified Problems

Total re-planning and redesign will be required due to the constructed MRT-3 and Muñoz Station and the Pedestrian Bridges at the intersection.

#### Recommendations

A careful study of the vertical and horizontal clearances against the constructed Muñoz Station and MRT-3 viaduct structures should be undertaken.

## **4.3.2 Preliminary Design of Interchange**

### **(1) Comparative Study**

The following three (3) alternatives are proposed as the most suitable schemes for comparison.

Scheme-1 : Flyover with 422m long and 3 lanes per direction. (Maintain of all pedestrian bridges )

Scheme-2 : Flyover with 366m long and 3 lanes per direction. (No pedestrian bridges near Muñoz Station)

Scheme-3 : Flyover with 719m (NB) and 880m (SB) long. (Maintaining all pedestrian bridges and improving at grade intersection)

Among the three (3) alternatives, scheme-2 was selected having the cheapest construction cost, shorter construction duration and superior vertical grade against the other schemes.

### **(2) Cost Estimate and Construction Duration**

Estimated cost and construction duration is PhP XXX M and 22 months, respectively.

#### 4.4 EDSA/ North Avenue/ West Avenue/ Mindanao Avenue

##### 4.4.1 Review of Previous Detailed Design

###### EDSA Southbound

The total length of the project section and the flyover are 854m and 361m, respectively. The length of the left turn flyover (EDSA–North Avenue) which is located above the EDSA northbound flyover is 286m.

###### EDSA Northbound

The total length of the project section and the flyover are 569m and 343m, respectively.

###### EDSA–North Avenue Left Turn Flyover

⇒ North Avenue Straight

Total length of project section = 1,228m;

Length of flyover = 1,011m

⇒ North Avenue–Mindanao Avenue

Total length of project section = 306m;

Length of flyover = 180m

###### West Avenue–North Avenue Flyover

The flyover has two lanes and horizontal alignment of 80m radius right curve at the intersection which merges with EDSA–North Avenue Left Turn Flyover after the curve. The lengths of the project section and flyover are 483m and 392m, respectively.

###### Identified Problems

- (a) Requires total re-planning and redesign due to the planned construction of the Common Station along LRT-1 in front of SM North, and MRT-7 which will pass along North Avenue.
- (b) The construction of a Left Turn Flyover from EDSA to North Avenue will not be possible with the planned construction of the Common Station.

###### Recommendations

The necessary data and information on the MRT-3 and LRT Line-1 extension and detailed design of the Common Station and MRT 7 should be obtained for Preliminary Design.

##### 4.4.2 Preliminary Design (EDSA/North/West Interchange)

###### (1) Comparative study

The following two (2) alternatives are proposed as the most suitable for comparison:

Scheme-1 : Flyover with 342m long north bound and 319m long south bound.

Scheme-2 : Cut and cover tunnel with 231m long north bound and 131m long south bound.

Between the two (2) schemes, the flyover scheme was selected due to cheaper construction cost, no ROW acquisition, shorter construction duration and no specific O & M.

##### 4.4.3 Preliminary Design (North/Mindanao Interchange)

###### (1) Comparative study

The following two (2) alternatives are proposed as the most suitable for comparison:

Scheme-1 : Left turn flyover from North Ave to Mindanao Ave (3<sup>rd</sup> level) and left turn flyover from Mindanao Ave to North Ave (2<sup>nd</sup> level)

Scheme-2 : Left turn cut and cover tunnel from North Ave to Mindanao Ave (under pass) and left turn flyover from Mindanao Ave to North Ave (2<sup>nd</sup> level).

Between two (2) schemes, scheme-2 was



selected due to cheaper construction cost and better environmental and traffic conditions.

**(2) Cost Estimate and Construction**

**Duration**

Estimated cost and construction duration for the above two interchanges are MP XXX and 24 months, respectively.

**4.5 C-5/Kalayaan Avenue**

**4.5.1 Review of Previous Detailed Design**

Identified Problems

The U-Turn Flyovers constructed at both sides of the intersection along C-5 are considered to be substandard structures under the design code.

Recommendations

A more comprehensive study of actual traffic flow and volume at the intersection needs to be undertaken to identify the cause of traffic jam and to study proper counter measures.

**4.5.2 Advice for Technical Issue and Design Option**

**(1) Site Condition and Traffic survey**

Three (3) issues were identified:

- a) Carriageway width of C5 thru traffic is substandard.

- b) Subtle curve alignments along C5 for thru traffic in both directions were observed around the U-turn flyover.

- c) Traffic survey data shows that passing vehicles along U-turn flyover at south side and north side are 25,132 vehicles per day and 18,600 vehicles per day, respectively. Summarized actual traffic intersection flow graphic are shown as follows:

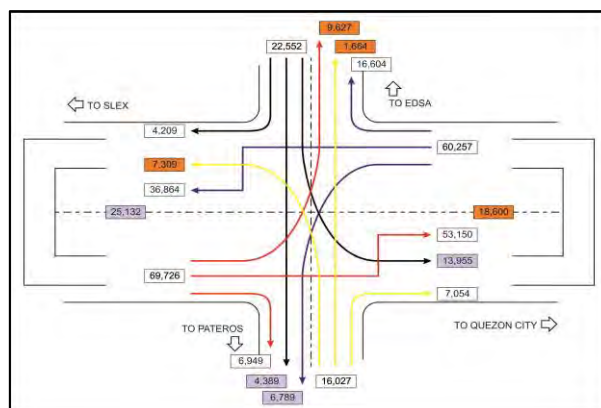

Source: JICA Study Team

**(2) Technical study maintaining existing U-turn flyover**

Maintaining existing U-turn flyover and from above traffic data, the following five (5) schemes were studied:

Option	AADT	Findings	Reduced Conflict No. (Present conflict is 5)
Scheme -1 Construct left turn flyover from Kalayaan Ave. to C5 north bound	13,955	Require ROW acquisition but Tibagan elementary is located along C5 north bound.	-2
Scheme -2 Construct left turn flyover from Pateros to C5 north bound	7,309	Comparatively traffic volume is small and requires ROW acquisition	-1
Scheme -3 Construct straight flyover along Kalayaan Ave.	6,053	Traffic volume is small	-1
Scheme -4 Construct left turn flyover from C5 south bound to Pateros	6,789	Not enough transition length	-1
Scheme -5 Construct left turn flyover from C5 north bound to EDSA	9,627	Not enough transition length	0

Source: JICA Study Team

Among the above five (5) schemes, the most effective option is to construct left turn flyover from Kalayaan Ave. to C5 north direction but it should be noted that the Tibagan elementary school is located just beside of road along C5 north direction.

**(3) Technical study with demolition of existing U-turn flyover**

New intersection plans provide for three (3) lanes in each direction with underpass scheme along C5 for thru traffic. Based on the traffic volume and traffic flow at the intersection, four (4) schemes as new intersection plans can be considered as shown in the comparison table hereunder.

Description	Signal Phase	Traffic Reduction Ratio	Length and Cost of Flyover (m)	Overall Evaluation/Ranking	
<b>Scheme-1</b> No structure for grade separation	4-Phase	$\frac{0}{43.733} = 0\%$	Closed due to confidentiality	* Manage 4-phases signalization * No cost, no improvement	4
<b>Scheme-2</b> *Left turn flyover from Kalayaan Ave. to C5 both direction	3-Phase	$\frac{21.264}{43.733} = 48.6\%$		* Most effective plan due to almost 50% of traffic is free flow	1
<b>Scheme-3</b> *Straight flyover along Kalayaan Ave.	3-Phase	$\frac{6.057}{43.733} = 13.8\%$		* Requires budget is reasonable but effectiveness to the traffic flow is small	3
<b>Scheme-4</b> *Left turn flyover from C5 both direction to Kalayaan Ave.	3-Phase	$\frac{16.416}{43.733} = 37.5\%$		* 2nd effective plan due to almost 40% of traffic is free flow	2

Note: 1) Traffic rate : Ratio of number of traffic vehicle pass the flyover against total volume of traffic at intersection except along C5 thru traffic and right turn traffic (total volume of traffic for calculation is 43.733 vehicles)

2) Number of lane for all flyover is 2-lane

3) Cost of flyover : P 300,00/m/lane

Source: JICA Study Team

**(4) Overall evaluation**

With existing U-turn flyover

- Existing substandard carriageway widths and subtle curve alignments are the cause of unsmooth traffic around both sides of the U-turn flyover and that becomes the bottlenecks for C5 thru traffic and there are no remedial measures without demolishing the existing u-turn flyover. Most optimum option is the construction of a left turn flyover from Kalayaan Ave to C5 in both directions, but ROW problem is existence (Tibagan elementary school is located at just beside of north bound of C5).

Without existing U-turn flyover

- Construct underpass 3-lanes in each direction along C5.
- Construction of left turn flyovers from kalayaan Ave. to C5 in both directions will be the most effective scheme considering that almost 50% of traffic will be free flow
- Estimated cost are as follows:
  - Construction of 2-lanes Flyover (total length 740m) = XXX MP
  - Construction of 6-lanes Underpass structure (490m) = XXX MP
  - Demolition of existing U-turn flyover = XXX MP

Total = XXX MP

#### **(5) Recommendation**

##### With U-turn flyover

- To find a solution for the ROW problem (Tibagan elementary school) for improvement of intersection with present condition of U-turn flyover.

##### Without U-turn flyover

- To construct 6-lanes underpass for C5 thru traffic and 2-lanes left turn flyover from Kalayaan Ave. to C5 in both directions.

##### Total Recommendation

Implementation of the above without a U-turn flyover is recommended because the study shows that there is no ultimate solution that could fully address the expected yearly increase traffic without demolition of the existing U-turn flyover.

#### **4.6 C-5-Green Meadows Avenue**

##### **4.6.1 Review of Previous Detailed Design**

###### **(1) Design Plan**

The 925m long and four (4) lanes cut and cover tunnel was initially designed.

###### Identified Problems

There is no study on the complicated construction procedure for a tunnel underneath the existing creek.

###### Recommendations

Based on the problems identified, the proposed improvement should be carefully and thoroughly studied.

#### **4.6.2 Preliminary Design of Interchange**

##### **(1) Study of White Plains Creek**

The proposed inverted siphon cannot be adopted for the following reasons:

- (a) The calculation result of the loss of head of inverted siphon is 1.3 m. Therefore, at the time of freshet, the water level will rise 1.3m higher than the present condition at the upstream side.
- (b) It is expected that much garbage will flow at the time of freshet because the creek is flowing through a residential area.

##### **(2) Comparative Study**

The following three (3) alternatives are proposed as the most suitable for comparison:

- Scheme-1 : 1098m long flyover
- Scheme-2 : 808m long Cut and cover tunnel
- Scheme-3 : 432m long flyover and 80m long cut and cover tunnel

Among the three (3) schemes, scheme-1 was selected due to: Construction cost is cheapest, no ROW acquisition, and much easier construction, can provide four (4) lanes in each direction at the total stretch of area underneath the viaduct and will not require specific O&M.

##### **(3) Cost Estimate and Construction Duration**

Estimated cost and construction duration are MP XXX and 24 months, respectively.

## 5. IMPLEMENTATION SCHEDULE

### 5.1 Study of Contract Package Arrangement

Proposed contract packages were decided considering the size of contract and location of each flyover as follows:

**Package-1:** EDSA/North/West/Mindanao:

XXX million pesos

**Package-2:** C5/Green Meadows:

XXX million pesos

**Package-3:** EDSA/Roosevelt/Congressional

XXX million pesos

C-3/E. Rodriguez Interchange was canceled due to conflict with on-going project of Skyway Stage-3.

### 5.2 Study of Consultancy services

Consultancy services are required at Detailed Design Stage (12 months), Tender Assistance Stage (12 months) and Construction Supervision Stage (26 months). Total amount of proposed consultancy cost is XXX MP (XXX MY) including 5% contingency.

### 5.3 Project Cost Estimate

Total project cost is XXX million Pesos and loan amount is XXX million Yen, equity of Government of the Philippines is XXX million Pesos.

Summary of the project cost is shown in **Table 5-1**.

**Table 5-1 Summary of Project Cost**

Closed due to confidentiality
-------------------------------

Source: JICA Study Team

5.4 Total proposed implementation schedule is presented as follows:

IMPLEMENTATION SCHEDULE OF MMICP

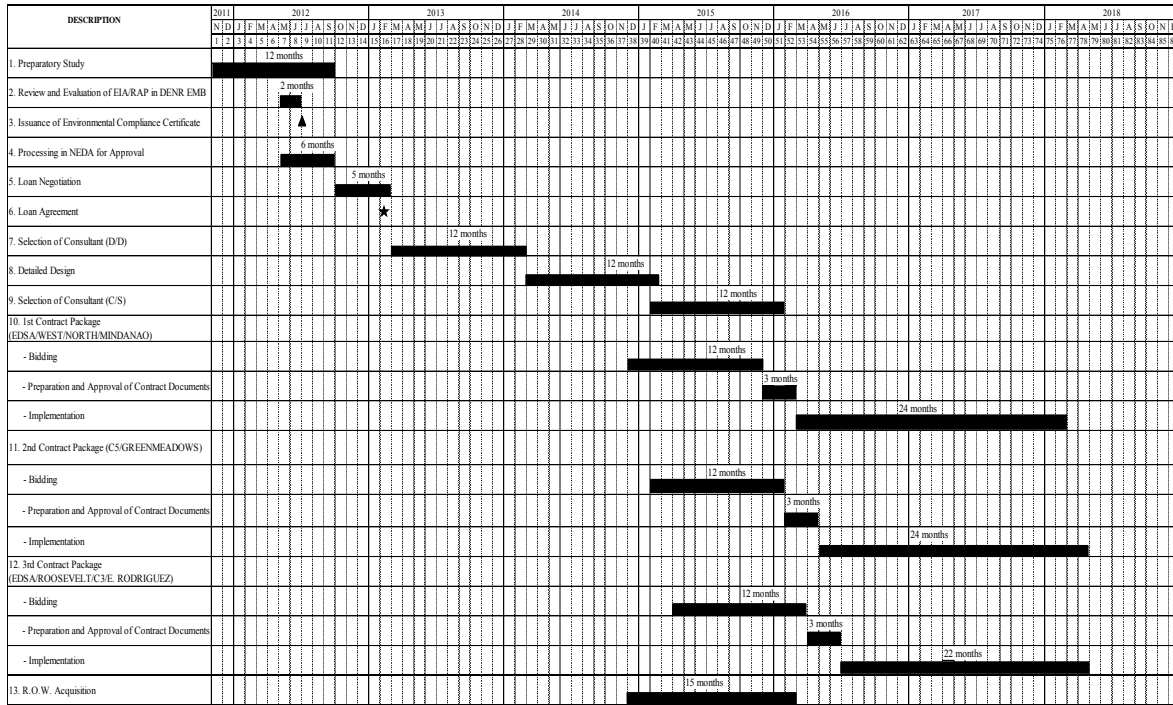

Source: JICA Study Team

5.5 IDEA AND BASIC CONCEPT FOR STEP SCHEME

Proposed use of steel bridge, with steel box girder, steel slab deck and steel piers utilizing Japanese technology, as shown in Figure, will remove the risks of the original detailed design plan mentioned above and minimize traffic congestion during the construction of superstructure.

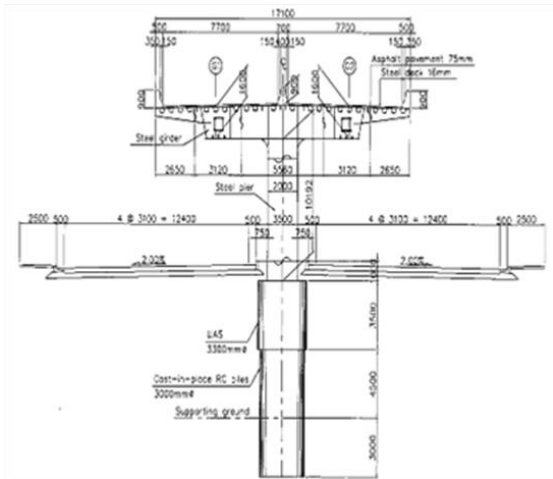

Procurement Amount from Japan for the Project

(Unit: Pesos)

No.	Description	Amount	%
1.	Cement (Material Only)	XXX	XXX
2.	Reinforcing Steel Bar (Material Only)	XXX	XXX
3.	Procurement of structural steel members (Material Only)	XXX	XXX
4.	Structural Steel (Material Only)	XXX	XXX
5.	ERMSE Wall (Material Only)	XXX	XXX
6.	Service of Japanese Contractor	XXX	XXX
<b>TOTAL</b>		<b>XXX</b>	<b>43.61</b>

Source: JICA Study Team

The total amount of Japanese content, at XXX million yen, is XXX% of the total XXX million yen construction cost under STEP scheme. Furthermore, procurement ratio becomes 43.61% once the XXX% of overhead of the Japanese contractor is added. The Japanese content proposed above therefore is adequate to satisfy the required 30% procurement ratio under STEP scheme condition.

Summary of Project Cost (STEP Loan)

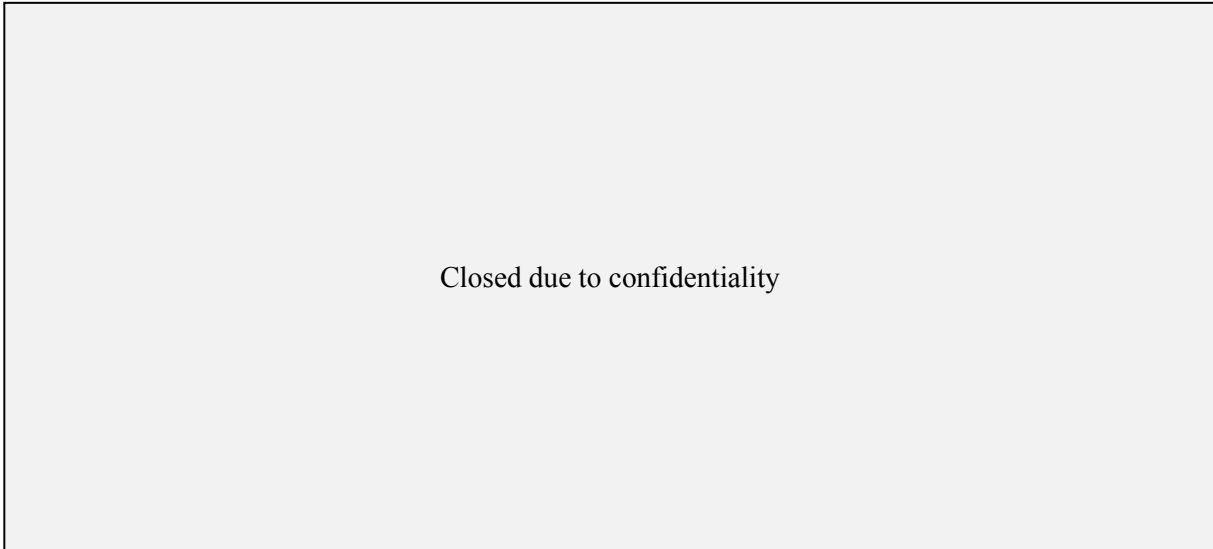

Source: JICA Study Team

Implementation Schedule of MMICP (STEP Loan)

	2013			2014			2015			2016			2017			2018		
<b>Pledge</b>	[Gantt chart bar]																	
<b>Signing of Loan Agreement</b>	[Gantt chart bar]																	
<b>Procurement of DD Consultants (2)</b>	[Gantt chart bar: DD consulting service]																	
<b>Detailed Design (12)</b>	[Gantt chart bar]																	
<b>Selection of CS Consultant (12)</b>	[Gantt chart bar: CS consulting service]																	
<b>Selection of Contractor (ICB with P/Q) (14)</b>	[Gantt chart bar]																	
- Document creation and JICA Concurrence (3)	[Gantt chart bar]																	
- Prequalification (3)	[Gantt chart bar]																	
- Bidding (2)	[Gantt chart bar]																	
- Evaluation of Bidding Documents (2)	[Gantt chart bar]																	
- JICA Concurrence (1)	[Gantt chart bar]																	
- Negotiation (2)	[Gantt chart bar]																	
- JICA Concurrence on Contract (1)	[Gantt chart bar]																	
<b>Construction Supervision (23)</b>	[Gantt chart bar]																	
<b>Land Acquisition (6)</b>	[Gantt chart bar]																	
<b>Construction</b>	0	0	9	12	2	0	0	0	0	0	0	0	0	0	0	0	0	0
- EDSA/North-West IC	0	0	9	12	0	0	0	0	0	0	0	0	0	0	0	0	0	0
- North/Mindanao IC	0	0	9	12	2	0	0	0	0	0	0	0	0	0	0	0	0	0
- CS/Green Meadows IC	0	0	9	12	2	0	0	0	0	0	0	0	0	0	0	0	0	0
- EDSA/Roosevelt IC	0	0	9	12	0	0	0	0	0	0	0	0	0	0	0	0	0	0

Source: JICA Study Team

### 5.6 Summary of Comparison between STEP Loan and Regular Yen Loan

The characteristics and advantages of both types of loans are shown in the table below.

Description		STEP Loan	Regular Yen Loan	Remarks
1. Bridge Type		PC Voided Slab Bridge + Steel Box and Steel Deck-Slab Bridge	PC Voided Slab Bridge	
2. Total Construction Cost		PHP XXX M	PHP XXX M	Cost is PHP XXX M or 14.9% higher under STEP
3. EIRR (%)	EDSA/North/West	Closed due to confidentiality		
	North/Mindanao			
	EDSA/ Roosevelt			
	C-5/Greenmeadows			
4. Construction Duration (per Flyover)		22~23 months	23~24 months	Reduce 1 month
5. Period of Traffic Control at Intersection		10 days	270 days	
6. Detailed Design		Under JICA Grant	Under Loan	Estimated Detailed Design Cost is PHP XXX M
7. Interest Rate of Loan		0.2% p.a.	1.4% p.a.	
8. Grace Period and Repayment Duration		10 years and 40 years	7 years and 30 years	

Initial investment is high under STEP loan and, correspondingly, low EIRR, but it has the following advantages:

- (a) Relatively shorter duration of construction per flyover;
- (b) Traffic control at intersection is much shorter;
- (c) PHP XXX M estimated cost of detailed design will be undertaken under JICA Grant;
- (d) Very low and fixed interest rate (0.2%) and long-term repayment period.

**6. EVALUATION OF PROJECT EFFECTIVENESS**

Economic analysis of the Metro Manila intersections, namely, C-3/E. Rodriguez, EDSA-Roosevelt, EDSA-North/ West, North-Mindanao, C-5/Green Meadows and these aggregate were undertaken with EIRR and ENPV as efficiency measurement indicators, for the Middle Income Countries General Condition (GC) loan and the STEP loan.

Conversion factors to estimate economic costs and unit prices of Vehicle Operation Cost (VOC-Running and Time costs, DPWH 2008)

	Passenger Car	Jeepney	Utility Vehicle	Bus	Truck	Motorcycle
Running Cost (V-km)	8.6	7.1	7.5	23.1	31.6	1.5
Time Cost (V-Hr)	408.4	446.6	154.2	1,669.2	109.7	89.9

Analytical results and sensitivity analysis for the STEP loan are summarized hereunder, with EIRRs profoundly revealing the worthiness of MMICP to the national economy. As such, the

STEP loan

	EDSA/Roosevelt	EDSA/North/West	North/Mindanao	C-5/Green Meadows	Aggregate
EIRR (%)	Closed due to confidentiality				
ENPV (PhP mill)					
Cost 15% Up					
Benefit 15% Down					
C-B Combination					

Qualitative benefits include, among others, an improved business operations environmental ambiancy with lesser CO<sub>2</sub> emission and noise, road safety and reduction of traffic accidents. Improvement in the institutional capability of the DPWH in newer technologies such as tunneling and quick-construction techniques, through the MMICP will help increase efficiency of public service in the future.

**Table 6-1** shows proposed monitoring plan for operation and effect indicators of the project.

were updated to 2012 price level.

In the STEP loan case, the economic cost for each intersection was PhP XXX million, PhP XXX million, PhP XXX million, PhP XXX million, and total PhP XXX million.

Furthermore, the annual investment rate over the six year construction period is assumed to be XXX%, XXX%, XXX%, XXX%, XXX% and XXX%.

Note that the implementation of the C-3/E. Rodriguez was cancelled by the DPWH to give priority to the construction of Skyway Stage 3 along C-3 under BOT scheme.

commencement of the project at an early stage of time would be recommendable by securing Japan’s ODA financing loan facilities as an option.



**Table 6-1 Monitoring Plan for Operation and Effect Indicators**

Indicators		Vehicle Type	Base Year (2011)	Target Year* (2019)	Monitoring Location
Traffic Volume (veh/day)	EDSA/Roosevelt/ Congressional Intersection	Car	65,107	69,126	Along EDSA: Cubao Side
		Jeepney	2,302	8,925	
		Utility Vehicle	8,064	6,524	
		Bus	10,134	12,415	
		Truck	7,035	2,968	
		Bicycle	7,171	18,210	
		<b>Total</b>	<b>99,813</b>	<b>118,167</b>	
	EDSA/West/North Intersection	Car	129,372	130,786	Along EDSA: Cubao Side
		Jeepney	2,119	0	
		Utility Vehicle	5,080	6,691	
		Bus	10,432	13,593	
		Truck	8,119	4,211	
		Bicycle	11,259	23,703	
		<b>Total</b>	<b>166,381</b>	<b>178,985</b>	
	North/Mindanao Intersection	Car	43,406	44,645	Along North Ave.: EDSA Side
		Jeepney	12,209	10,963	
		Utility Vehicle	4,240	5,733	
		Bus	58	0	
		Truck	2,089	1,435	
		Bicycle	7,390	13,818	
		<b>Total</b>	<b>69,392</b>	<b>76,593</b>	
	C-5/Green Meadows/ Acropolis/Calle Industria Intersection	Car	77,269	112,519	Along C-5: Pasig City Side
		Jeepney	3,727	5,820	
		Utility Vehicle	14,679	18,539	
Bus		215	524		
Truck		9,765	6,244		
Bicycle		24,785	34,904		
<b>Total</b>		<b>129,440</b>	<b>178,551</b>		
Average Travel Speed in PM Peak (km/h)	EDSA/Roosevelt/ Congressional Intersection		16.2	62.2	Along EDSA: Northbound Flyover
	EDSA/West/North Intersection		19.9	33.6	Along EDSA: Northbound Flyover
	North/Mindanao Intersection		9.8	50.3	Along North Ave.: EDSA Side bound to Quezon Circle
	C-5/Green Meadows/ Acropolis/Calle Industria Intersection		29.3	51.0	Along C-5: Northbound Flyover

\* Target Year is two years after the completion of the Project, which is defined as the time when the Project is open to traffic.

Source: JICA Study Team

## 7. STUDY OF ENVIRONMENTAL AND SOCIAL CONSIDERATIONS

### Environmental Impact Assessment Study

- In accordance with the “JICA Guidelines for Environmental and Social Considerations (2002 April)” (hereafter referred to as JICA Guidelines), alternative schemes including a

zero option (without-the-project) case were analyzed and scoping was conducted. The results of scoping show that there are no significant adverse impacts on natural environment and socio-economic conditions. According to the criteria of PEISS, DPWH will submit the Initial Environmental Examination (IEE) reports to DENR EMB in

order to apply the Environmental Compliance Certificate (ECC).

- Noise, air pollutants and CO<sub>2</sub> emissions emitted from vehicles are predicted based on the projected traffic in 2018. The results of prediction show that the noise levels may exceed the Philippine maximum permissible levels due to the increase of traffic volume. Because of the increase of average travel speeds and the decrease of vehicle hours, emissions of air pollutants and CO<sub>2</sub> will be reduced by approximately 10 - 20% compared with the zero option case. Air pollutant concentrations might not exceed the maximum permissible levels of the Philippine Clean Air Act of 1999.
- Technically feasible mitigation measures during the construction and operation phases are drawn up and proposed for the four interchange projects. After opening, the interchange, noise levels should be regularly monitored. Installation of noise barriers shall be considered where the noise levels significantly exceed the permissible levels in

residential zones. Trees should be planted in central reserves and sidewalks to improve the local aesthetic views and mitigate the noise and air pollutants emitted from vehicles.

- In order to ensure the effectiveness of mitigation measures and monitor the unexpected impacts, the Environmental Management Plans for the construction and operation phases should be drawn up. After the opening of the interchanges, replanted trees, ambient air quality, and noise and vibration should be regularly monitored.

Land Acquisition and Resettlement Action Plan (RAP)

- The results of the census survey and inventory (assets and land) survey are shown in Table 7.1. No involuntary resettlement is anticipated. The JICA Study Team supported the DPWH in preparing the Abbreviated Resettlement Action Plan in line with DPWH's Land Acquisition, Resettlement, Rehabilitation and Indigenous Peoples' Policy and JICA Guidelines/World Bank Operational Policies.

Interchange	Land Acquisition	Resettlement	Affected Structure
C-3/E. Rodriguez	None	None	None
EDSA/Roosevelt/Congressional	None	None	5 stalls (marginal* <sup>1</sup> )
EDSA/North/West/Mindanao	Additional ROW for sump pit (100 sq.m)	None	25 stalls (marginal* <sup>1</sup> )
C-5/Green Meadows/Acropolis/Calle Industria	None	None	None

**Table 7-1 Land Acquisition, Involuntary Resettlement and Affected Structure for MMICP**

Source: JICA Study Team

Note : the impact is only partial and the remaining portion of the property or asset is still viable for continued use.

Support DPWH to hold Public Consultation Meetings

- DPWH assisted the JICA Study Team with the Public Consultation Meetings at four interchange project sites. The stakeholders favored the interchange projects to ease the present traffic congestion. There were the

comments on the implementation of the Traffic Management Plan during construction, noise mitigation measures and restoration of cut trees. DPWH will draw up the proper countermeasures in the planning stage of the interchange projects against these issues raised by stakeholders.

## 8. C-3 MISSING LINK

### 8.1 Background to the Study on the C-3 Missing Link

The southern segment (hereafter referred to as the C-3 Missing Link) of C-3 has not yet been implemented to date. The circumferential road network serving south-central Metro Manila is therefore not effectively functioning resulting in heavily congested traffic conditions on EDSA. The construction of the C-3 Missing Link is expected to have a substantial impact on improving the circumferential road network in Metro Manila and on decongesting EDSA. The study involved review of the C-3 missing link construction project report and also study of influence to the proposed flyovers by the captioned project.

### 8.2 River Systems

- Pasig River

The average width of Pasig River is 91m and average depth is 4m with the deepest sections being 6m. Flow volume can be as low as 12cum/sec in the dry season whereas during the rainy season flow can increase to 275 cum/sec.

The Ayala Bridge is the lowest bridge, with a vertical clearance of only 3.5m above high water level.

- San Juan River

The width of the river in the project area is typically 40m-50m. The river is flood prone over most of its length with wide areas of floodwater breakout, including within the project area.

The San Juan River is not navigable and is outside of the mandate of the Philippine Coast Guard.

### 8.3 Alternative Alignments and DPWH

## Comparative Study

### 8.3.1 Alternative Alignments

The six (6) alternative alignments for the C-3 Missing Link together with a comparative study was prepared by DPWH URPO. These alignments are presented below.

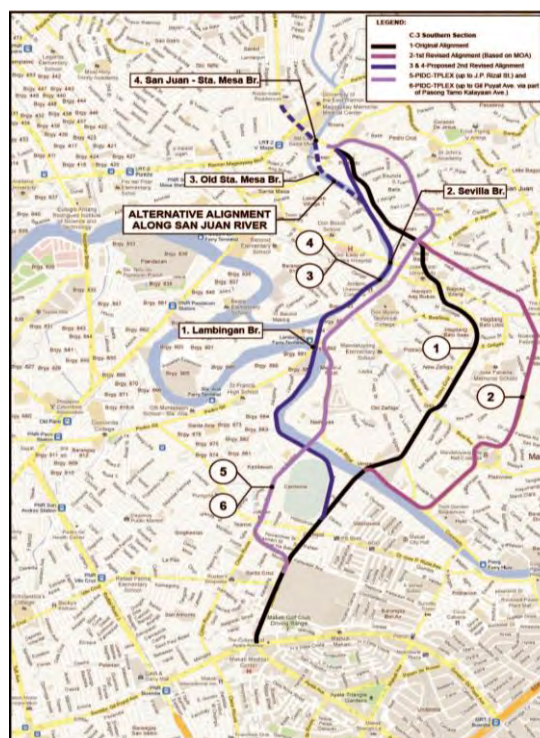

### 8.3.2 DPWH Comparative Study

The 6 alternatives were presented considering the following items: length of each alternatives, number of lanes, structural type, cost of RROW, construction cost and total cost.

The report also presented advantages and disadvantages for all alternatives but there was no mention of which alternative was superior or even did not make comparative rankings among the alternatives.

### 8.3.3 Review of DPWH Comparative Study

The Study Team conducted a review of the DPWH comparative study and established the following evaluation criteria: 1) Proposed

Scope of Work, 2) Construction Issue, 3) R.O.W. Acquisition, 4) Resettlement Issue, 5) Environmental Issue, 6) Navigation Issue in Pasig River and 7) Construction Cost.

## 8.4 Updated Study

### 8.4.1 Geometric Design Standards

Design conditions of the project adopted the design criteria of the DPWH.

### 8.4.2 Typical Cross Sections

The number of lanes assumed for the alternative alignments is taken to be the same as the existing C-3 Northern Segment, a 6 lane divided

	At Grade	Elevated Single Deck	Elevated Double Deck	Total	R.O.W. Acquisition
Alternative-1	1.05km	0.80km	3.95km	5.8km	102,000m <sup>2</sup>
Alternative-2	1.05km	1.60km	4.65km	7.3km	105,000m <sup>2</sup>
Alternative-3	0.0km	4.55km	1.75km	6.3km	35,000m <sup>2</sup>
Alternative-4	0.0km	4.55km	1.75km	6.3km	92,000m <sup>2</sup>
Alternative-5	1.55km	0.15km	3.40km	5.1km	74,000m <sup>2</sup>
Alternative-6	1.15km	0.15km	5.10km	6.4km	77,000m <sup>2</sup>

#### (1) Viaduct Configuration

Single level viaduct structures are proposed as a preferred configuration. However, where available ROW is limited, double deck viaducts have been proposed. Long span bridges, at a range of 50m to 100m or so, will be necessary to cross the Pasig River, and the San Juan River.

#### (2) Interconnectivity with Local Roads

The interconnectivity of the proposed alternative alignments with local roads is a key aspect in promoting the functionality of each route. 2-ramps are planned for each alternative, namely: Boni. Ave. and New Panaderos in the south side and Shaw Blvd. in the north side.

#### (3) Navigation Issues in Pasig River

The section of Pasig River just upstream of Lambingan Bridge is already posing

road.

A road bridge over inland waterways must have a minimum vertical clearance of 3.75m from the highest water level, while the San Juan River is not navigable.

Based on the above conditions, five (5) types of typical cross sections were prepared, namely: 1) at grade section, 2) viaduct on ground, 3) double deck viaduct on ground, 4) along Pasig River, and 5) along San Juan River.

### 8.4.3 Scope of Work of Each Alignment

The scope of work for each alignment is presented in table below:

navigational problems for the larger vessels plying the river. Any obstructions in the river reducing the navigable width will further exacerbate the already difficult situation.

#### (4) San Juan River Issues

San Juan River is not navigable and therefore not subject to consideration of vessel navigation and ship collision forces.

### 8.4.4 Project Affected Buildings and Project Affected People

The numbers of affected buildings and people have been identified from open source satellite images. Informal settlements are located beside SM City Sta. Mesa near C-3 road side.

### 8.4.5 Environmental Issues

The conducted environmental study for all

proposed alignments considered road side air pollution and noise impact, sun light easement and water quality deterioration. All of these items are conditions judged having minor influence.

### 8.4.6 Rough Cost Estimate

The estimate of construction cost and cost of R.R.O.W. acquisition were calculated based on similar completed and on-going projects data. Estimated cost is as follows:

Alignment	Construction Cost (MP)	ROW Acquisition/ Land Improvement Cost (MP)	Total (MP)
1	12,000	5,600	17,600
2	14,700	5,700	20,400
3	16,400	2,100	18,500
4	14,600	4,700	19,300
5	9,600	4,100	13,700
6	13,900	4,400	18,300

### 8.4.7 Updated Comparative Study

The comparative study of the six alignments for the C-3 Missing Link is presented as follows:

Ref	Description	Construction Aspects and Cost	Environmental Impact & Pasig River Navigation	ROW Acquisition (excluding ramps)	Project Affected People	Comment
1	Original Alignment (6 Lane, 5.8 km.)	Adequate traffic management during construction will be crucial. COST: 17,600MP	Since the route is established in the populated residential area, the impacts of emission gases, noise and sunlight shading will be the most significant among the alternatives and must be mitigated. Number of impacts: 8	Very substantial ROW acquisition (102,000 sqm). Requires wholesale demolition at: Olympia Ville, Mandaluyong Cemetery, Core Oil Gas Station, Barangay Hall Bagong Silang, and residential blocks from Valenzuela to N. Domingo. Encroachment into Manila South Cemetery is avoided with double deck viaduct along South Ave.	Maximum estimated number of PAPs at 4,430.	Large area of ROW acquisition and largest number of PAPs makes this one of the least favored routes.
2	1 <sup>ST</sup> Revised Alignment (6 Lane, 7.3 km.)	Adequate traffic management during construction will be crucial. COST: 20,400MP	Since the route is established in the populated residential area, the impacts of emission gases, noise and sunlight shading will be the most significant among the alternatives and must be abated. Number of impacts: 8	Greatest ROW acquisition (105,000 sqm). Requires wholesale demolition at: Olympia Ville, residential blocks at corner of Coronado-San Francisco, along Maytunas Creek (partial), and residential blocks from Valenzuela to N. Domingo. Encroaching into Manila South Cemetery is avoided with double deck viaduct along South Ave.	Second largest estimated number of PAPs at 3,925.	Largest area of ROW acquisition and very large number of PAPs makes this one of the least favored routes.
3	2 <sup>ND</sup> Revised Alignment a1 (6 Lane, 6.3 km.)	Access along both waterways will be required for construction. Barges could be used both to deliver materials and as a platform for construction equipment along Pasig River. Craneways may be necessary along San Juan River given that the river is not navigable. COST: 18,500MP	Piers will be constructed on the riverbeds in Pasig River and San Juan River. Installation of piers and untreated storm runoff may deteriorate river water quality. Ease of navigation along Pasig River will be severely impacted especially where the river narrows and at the point where the rivers bends 90 degrees on the approach to Lambingan. Number of impacts: 3	Least ROW acquisition (35,000 sqm) given that most of alignment is in Pasig and San Juan River. There is a requirement to partially demolish Olympia Ville, between Kalayaan Avenue and J.P. Rizal. Encroachment into Manila South Cemetery is avoided with double deck viaduct along South Ave.	Smallest estimated number of PAPs at 550.	Most favored in terms of limiting area of ROW acquisition and number of PAPs. However construction along sections of Pasig River may not be possible given the existing critical navigation problems.

4	2 <sup>ND</sup> Revised Alignment a2 (6 Lane, 6.3 km.)	Construction access along the river banks can be made after the easement has been cleared. No construction activities are required in the river waterways.  COST: 19,300MP	Since the route is established in the populated residential area, noise abatement measures will be needed. Number of impacts: 4	Still substantial ROW acquisition (92,000 sqm) given the need to acquire ROW along the river banks of Pasig and San Juan River. Substantial demolition of industrial and residential properties. There is a requirement to partially demolish Olympia Ville, between Kalayaan Avenue and J.P. Rizal. Encroachment into Manila South Cemetery is avoided with double deck viaduct along South Ave.	Second smallest estimated number of PAPs at 950.	Reasonably favored in terms of limiting number of PAPs. No adverse impacts on river waterway or navigation. However construction along the banks will still require substantial ROW acquisition.
5	PIDC-TPLEX Alignment b1 (6 Lane, 5.1 km.)	Adequate traffic management during construction will be crucial.  COST: 13,700MP	Since the route is established in the commercial and residential area, the impacts of emission gases, noise and sunlight shading should be mitigated. Number of impacts: 6	Double deck configuration limits ROW acquisition (74,000 sqm). However many properties affected including commercial buildings especially along New Panaderos and F. Bulmentritt. Curved alignment cuts the corner at F. Blumentritt requiring wholesale demolition in one section.	Estimated number of PAPs still substantial at 1,765.	Route not favored since it does not extend to Gil Puyat.
6	PIDC-TPLEX Alignment b2 (6 Lane, 6.4 km.)	Adequate traffic management during construction will be crucial.  COST: 18,300MP	Since the route is established in the commercial and residential area, the impacts of emission gases, noise and sunlight shading should be mitigated. Number of impacts: 6	Double deck configuration limits ROW acquisition (77,000 sqm). Affected properties same as above. In addition ROW acquisition along Kalayaan Avenue will be required. Encroachment into Manila South Cemetery is avoided with double deck viaduct along South Ave.	Estimated number of PAPs still substantial at 2,085.	Route not favored given the need for ROW acquisition along commercial strips, despite double deck construction, and wholesale demolition in Blumentritt to accommodate the curved alignment.

Source: JICA Study Team

#### 8.4.8 Effect on the Project Interchanges due to Construction of the C-3 Missing Link

The effect on the Project interchanges due to construction of the Missing Link was analyzed using MMUTIS's data.

Result of the effects on each of the intersections are so follows:

(a) C-3/E. Rodriguez

The south side of this intersection directly connects to the Missing Link; therefore, the effect is substantial. Traffic along C-3 will increase by 26-56%.

(b) EDSA/Roosevelt/Congressional

The traffic on Roosevelt Avenue connecting to the Missing Link will increase by 46%, but the effects on traffic volume for other roads connecting to the interchange are minimal.

(c) EDSA/North/West/Mindanao

Traffic on West Avenue will be reduced by about 30% due to traffic diverting to Roosevelt Avenue. Effects on traffic volume for other roads connecting to the interchange are minimal.

(d) C-5/Kalayaan

C5 is parallel to the Missing Link. Traffic on Kalayaan Ave. will increase by about 10%. And traffic on C5 will decrease by about 10%.

(e) C-5/Green Meadows/Acropolis

C5 is parallel to the Missing Link but far from the Missing Link. The effect on traffic volume is minimal.

#### 8.4.9 Recommendations

The most favored alignments are those that follow the Pasig and San Juan Rivers. These alignments are favored since both of the number of affected buildings and PAP's are minimized and also the least environmental impacts are

expected.

However, both alternatives have drawbacks: navigation problems in Pasig River; obstruction of waterway area in San Juan River; and a need for substantial ROW acquisition.

It is recommended that the Study on the C-3 Missing Link should be the subject of a feasibility study in establishing preliminary design, assessing traffic impacts and conforming economic viability.

#### 8.4.10 Related Proposed Projects in Metro Manila

In addition to the DPWH proposal for a C-3 Missing Link Project, there are several other proposals, from the private sector and other government agencies, to provide elevated roadways serving a similar function or occupying corridors that may intersect with the C-3 Missing Link Project. The other proposed projects are listed below:

	Proposed Project	Proponent
1	C-3 Expressway	Ayala Corporation
2	NLEX-SLEX Connector	Metro North Tollway Corp. (MNTC)
3	Metro Manila Skyway Stage 3	CITRA/PNCC
4	SKYBRIDGE	MMDA

### 9. THE CONCEPTUAL STUDY FOR THE TRAFFIC CAPACITY EXPANSION ALONG EDSA

#### 9.1 Background of the Project

The 24 km length of EDSA is the main circumferential road of Metro Manila and has average traffic of more than 200,000 vehicles per section every day. Notwithstanding the improvements to EDSA brought by the construction of several interchanges, in addition to the MRT-3 and LRT-1 North Extension, the limited capacity of EDSA to handle the large

daily volumes of traffic from early morning to late evening has resulted in severe congestion and low traffic speeds. Such situation is severely hampering the socio-economic development of Metro Manila and is an impairment to the environment.

In view of the above critical condition, a ceptual Study on Traffic Capacity Expansion along EDSA has been proposed.

#### 9.2 Objectives and Concept of Conceptual Study

The purpose of this conceptual study is to identify the outline of the possibility of constructing high level viaduct or tunnel solutions that will expand the capacity of EDSA and the study includes of find space for proposed viaduct structures.

#### 9.3 Confirmation of Consistency between the Proposed Project and Present Traffic Plans in the Metro Manila

Some existing plans of trunk roads, expressways and railways are related to the proposed study with regards to the share of traffic volume but these should not be affected or disturbed much in the implementation of the proposed project.

#### 9.4 Confirmation of Open Spaces for Tunnel Plan and Viaduct Plan

The study will confirm in outline the availability of open space to accommodate the support structures of high level viaduct solutions and tunnel solutions at critical locations along EDSA. The basic concept in assessing available space is to develop outline solutions that will minimize occupation of width along EDSA and also minimize ROW acquisition where and if necessary.

## 9.5 Confirmation of Hindrance Structures

The following hindrance structures for both directions on EDSA have been identified:

MRT/LRT Station : 15 stations

Flyover along/across EDSA: Southbound =13 locations, Northbound=14 locations

Under pass along/across EDSA :4 locations

Pedestrian Bridge : 30 locations

Those hindrance structures shown in the figure below:



Source: JICA Study Team

### Location Map of MRT-3, LRT-1 Stations, Flyover and Underpass

## 9.6 EDSA General Condition

### (1) Topology

EDSA generally has ten (10) lanes with five (5) equal lanes per direction. Within the 3.0 m sidewalks, various utilities including overhead cables are located at-grade, underground and in the air. A median separator exists throughout EDSA. Both the MRT-3 and LRT-1 North Extension fully occupies this corridor.

### (2) Traffic Condition

The traffic volume along EDSA has been steadily increasing every year. To ease traffic flow on EDSA, slow moving cargo trucks have been prohibited running on the major section between Makati and Quezon City. This

is imposed except on a specific time window which is from 9:00pm to 6:00am daily except Sundays and Holidays. To further decongest EDSA, a volume reduction scheme has been implemented to reduce daily traffic by twenty percent (20%) theoretically by prohibiting all vehicle types on the basis of its last digit plate number from 7:00am to 7:00pm.

## 9.7 Viaduct Scheme

### 9.7.1 Proposed Viaduct Plan and Profile

This concept will require columns and foundations over the current roadway. This will diminish the number of at-grade lanes in each direction from five to four. However, after the construction of the elevated viaduct, EDSA will have seven lanes in total in each direction.

For site conditions requiring long spans and high piers, steel box girders supported by rectangular steel columns are recommended.

### 9.7.2 Proposed Location of Ramps

The ramps give access to the major Central Business Districts (CBD) of Makati and Ortigas, and to the hub of government offices in Quezon City and distance between ramps are about 5.3km each.

The estimated additional RROW requirement for an elevated viaduct and the provided ramps on EDSA is roughly about 140,000 sq m.

### 9.7.3 Description of Five High Critical Hindrance Structures/Sections

The stretch of EDSA was examined to identify the five most difficult locations for viaduct construction. A list of the sites assessed against the major hindrance, the most difficult



construction and their exact locations are shown in the following figure:



Source: JICA Study Team

### Location of the Five Most Difficult Construction Sites

#### 9.7.4 Find Space for Proposed Viaduct Structures

There is a spaces for proposed viaduct Structures after construction of proposed flyover.

#### 9.7.5 Cost Estimate

Estimate Cost for construction of viaduct at the section, PhP 170 B will be required.

### 9.8 Tunnel Scheme

#### 9.8.1 Proposed Plan and Typical Cross Sections of Tunnel

The beginning and endpoint of the tunnel are located Roxas Boulevard, and Monumento Circle and Balintawak, respectively. The main tunnel consists of 2-lane tunnels at both sides of the entrance and exit while 3-lane tunnels shall be used for the entire middle section. 1-lane ramps shall be provided at four (4) locations.

#### 9.8.2 Standard Earth Covering of Tunnel

Computation of earth covering underground and under river are as follows:

- Underground :Same diameter of tunnel (1.0 x diameter of tunnel)  
(15m (estimated pile length) + 1.0 x 14.62=

29.6m > 30.0m)

- Under river :Two times of diameter of tunnel (2.0 x diameter of tunnel)  
(2 x 14.62= 29.2m > 30.0m)

#### 9.8.3 Ramp (Entrance and Exit)

One-lane ramp tunnel provided at four (4) locations, as follows:

- Between Skyway and Makati
- Before and after Ortigas Ave.
- Before and after Quezon Ave. and
- Between Balintawak and Roosevelt Ave.

Tunnel layout including ramp locations are shown in the figure below.

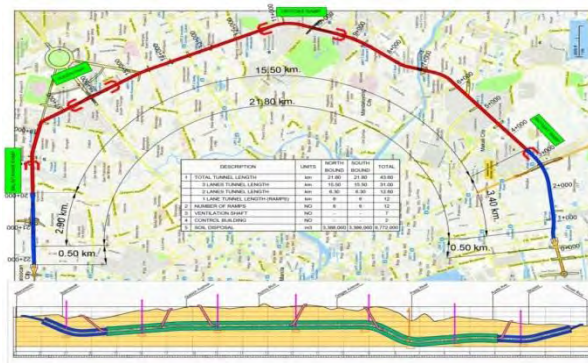

Source: JICA Study Team

#### Tunnel Layout (Plan and Profile)

#### 9.8.4 Ventilation System

The main function of the tunnel ventilation system is to discharge the vehicle exhausted fumes and smoke from fire. Airflow shall be diverted into two (2) sections underneath the deck slab of carriageway: one to discharge smoke and the other to take in fresh air which will also be utilized for people access to evacuation. General concepts of this system are shown in the following figure.

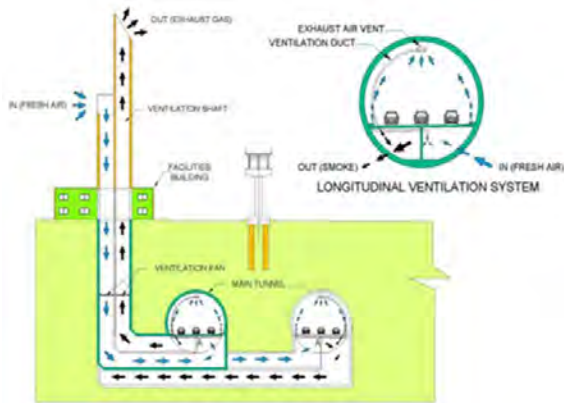

Source: JICA Study Team

### General Concept of Ventilation System

#### 9.8.5 Shield Shaft

Tunnel excavation will be done by one shield machine per direction between the departure vertical shaft and arrival vertical shaft. Shield tunnel construction works have routine works of excavation, assembly of precast concrete segments and grouting between concrete segment and soil.

#### 9.8.6 Required Tunnel Facilities

Based on “ installation standards of Emergency Facilities for Road Tunnel” issued by Japan Road Association, the proposed tunnel can be classified with the highest rank of “AA” which requires the provision of all type of facilities such as: 1) Emergency call and warning devices, 2) Fire extinguisher equipment, 3) Evacuation facilities, 4) Communication system, and 5) Water spray system.

#### 9.8.7 Construction Schedule

Based on the experience of past projects in Japan, total implementation of all the sections will take about 20 years if it is done in stage by stage continuous base.

#### 9.8.8 Cost Estimate

Rough cost will be estimated based on

completed projects and past experiences in Japan considering similar site conditions of EDSA. Estimated cost of 3-lanes and 2-lanes tunnels in the both directions are PhP 441B and PhP 331B, respectively.

## 10. SEMINAR ON LATEST JAPANESE ROAD AND BRIDGE CONSTRUCTION TECHNOLOGY

### 10.1 Objectives

The objective of the seminar was to introduce the latest Japanese technologies of road and bridge construction for understanding technical superior of STEP scheme for the proposed flyover project and also Filipino engineers to apply these to on-going and/or future projects. Said technologies are related to tunnel construction, asphalt pavement, rapid construction methods, bridge rehabilitation and improvement and quality control systems.

### 10.2 Seminar Program

Venue : H<sub>2</sub>O Hotel, Manila City

Date : March 6 and 7, 2012

- Day 1 (6<sup>th</sup> March)
  - Seminar 1 - Introduction of Japanese Road Technologies
  - Seminar 2 - Tunneling Construction Techniques
  - Seminar 3 - Pavement Technology
- DAY2(7<sup>th</sup> March)
  - Seminar 4 - Rapid Construction Methods (Concrete Bridge)
  - Seminar 5 - Rapid Construction Methods (Steel Bridge)
  - Seminar 6 - Bridge Rehabilitation and Improvement Technology
  - Seminar 7 - Quality Control System Technology

### 10.3 Attendance

#### (1) PHILIPPINES

Attendance for the seminar on the first day was 84 and 80 on the second day, mainly from DPWH personnel with 73% of share of attendees including the Honorable Secretary. Others are from other Government Agencies, LGU's, Private Sectors and the Academies.

#### (2) JAPAN

There were Fifteen (15) guest speakers for the seven sessions and eight (8) Japanese officials were attended.

### 10.4 Summary and Analysis of Questionnaire

Thirty nine (39) Questionnaires, summarized as follows were submitted to the attendees :

Q1- In this seminar, which subject interests you the most?

Tunneling Construction Technology ranked as the first by 17 persons, the second Pavement Technology, and the third Rapid construction Method (steel bridge).

Q2- What subjects would you consider for future projects or activities, and why?

Tunneling Construction Techniques, Pavement Technology ranked as the first with 10 persons each, the second was Rapid Construction Method (Steel Bridge), followed by Rapid Construction Method (Concrete Bridge) as the third in rank. This answer was similar to question-1 above.

Q3- Please give your comments about the seminar:

Almost all of the attendees were satisfied with the contents of each topic, imparted knowledge of new technology, excellent handouts and the the way how to manage the seminar. Some useful comments were presented: time of each topic was comparatively short, needed to be explained how the new technology will be applied and effective in the Philippines context, and the venue and the number of comfort rooms were rather narrow/a little.

### 10.5 Conclusion

The following items were opined to be the main reasons why the Seminar was satisfactorily conducted:

- a) All of the topics were interesting
- b) Presentation materials of speakers were interesting and excellent
- c) Proper arrangements of invitation to all relevant offices concerned with road and bridge construction.
- d) Almost all of the top officials of the DPWH including the Honorable DPWH Secretary attended.
- e) Issuing a Certificates of Attendance was Good arrangements.
- f) Invitation letters were issued in the name of the Honorable DPWH Secretary

## CHAPTER 1

### INTRODUCTION

#### 1.1 BACKGROUND OF THE PROJECT

Metro Manila has a strategic foothold for the economic activities of the Philippines that attracts 13% of the population and generates 37% of the total GDP of the country.<sup>1</sup> Metro Manila has been developing its transport sector infrastructure and pursuing traffic network improvements such as construction of circumferential roads, expressways and LRT etc., but still is faced with the problems of heavy traffic congestion and increased travel times until now. Such a situation creates a bottleneck in the distribution of goods and hampers the movement of people, resulting in huge economic losses, and is one of the reasons frequently cited for the deterioration of the economic competitiveness of the country. At the same time, chronic traffic congestion causes an increase in air pollution and noise.

The Department of Public Works and Highways (DPWH) has put a high priority in the construction of grade separated interchanges along with major interchanges intended to solve such negative issues which are identified as priority concerns in the Public Investment program (2011~2016) of DPWH. The construction of Circumferential Road 3 (C-3) missing link between N. Domingo Ave. in San Juan City and S. G. Puyat Ave. in Makati City over 6 km is expected not only to improve mobility of the residents along the road but also greatly relieve traffic congestion of EDSA and the metropolis. Furthermore, traffic capacity expansion of C-4 (EDSA), by construction of either elevated viaduct or underground tunnel, in addition to grade separation of major intersections and construction of C-3 missing link, is expected to provide fundamental solution to the chronic traffic congestion of EDSA.

In view of the above, the DPWH has requested the Japan International Cooperation Agency (JICA) to evaluate the possibility to finance the said high priority grade separated interchange construction projects in Metro Manila. The JICA has responded favorably to this DPWH request and has mobilized consultants to undertake Preparatory Survey for Metro Manila Interchange Construction Project (VI).

#### 1.2 OBJECTIVE OF THE STUDY

The objectives of the study are as follows:

1. The objective of the Study is to conduct screening of the proposed improvement as Japanese ODA Loan Project focusing on the items such as the purpose of the project, scope of works, project cost, project implementation organization, operation and maintenance organization

---

<sup>1</sup> National Census in 2007 by National Statistics Office of the Philippines

and social and environmental aspects based on previous detailed design and other related studies.

2. Conduct review and study for the preliminary engineering study on construction of Circumferential Road-3 (C-3) missing link includes of impact to the proposed flyover.
3. Conduct preliminary engineering study on traffic capacity expansion of Circumferential Road-4 (C-4) includes of find space for proposed viaduct structures.

### **1.3 STUDY AREA**

The Study covers Metro Manila of the Philippines.

### **1.4 SCOPE OF THE STUDY**

In order to achieve the above objectives, the Study covered the following:

#### **(1) Study of construction of interchanges**

- Feasibility Study for four (4) interchanges
  - 1) C-3/E. Rodriguez,
  - 2) EDSA/Roosevelt/Congressional,
  - 3) EDSA/North/West/ Mindanao
  - 4) C-5/Green Meadows/Acropolis
- Scheme study and preparation of design options
  - 1) C-5/Kalayaan

#### **(2) Study of the C-3 missing link includes of impact to the proposed flyover.**

- ✓ Review of six (6) alignments established by DPWH
- ✓ Establish evaluation criteria and undertake evaluation of alternative alignments

#### **(3) Study on C-4 traffic capacity expansion includes of find space for proposed viaduct structures.**

- ✓ Study on traffic capacity expansion for the construction of viaduct and tunnel schemes.

### 1.5 SCHEDULE OF THE STUDY

The study commenced in November 2011 and will be completed by end of November 2012 as shown in **Table 1.5-1**

**Table 1.5-1 Study Schedule**

Work Item	Year/Month	2011		2012												
		11	12	1	2	3	4	5	6	7	8	9	10	11		
Preparatory works in Japan		—														
【ITEM-1】 Confirmation of Necessity and Validity of the Project		■														
【ITEM-2】 Confirmation of Present Detailed design		■														
【ITEM-3】 Confirmation of the Scope of Works and Technical Examinations		■	■	■	■	■	■	■								
【ITEM-4】 Prepare Implementation Plan of the Project				■	■	■	■									
【ITEM-5】 Evaluation of Effectiveness of the Project					■	■	■									
【ITEM-6】 Investigation for Social Environmental Conditions		■	■	■	■	■	■	■	■	■	■	■	■	■	■	■
【ITEM-7】 Comparison Study of C-3 Missing Section		■	■		■	■	■									
【ITEM-8】 The Conceptual Study for the Traffic Capacity Expansion along EDSA				■	■	■	■									
【ITEM-9】 Implementation of Seminar and Record and Analysis of Seminar				■	■	■	■									
【ITEM-10】 Preparation of Reports		△		△			△	△	△	△	△	△	△	△	△	△

— Preparatory Work    ■ Work in the Philippines    □ Work in Japan    △—△ Report / Explanation  
 IC/R: Inception Report    IT/R: Interim Report    DF/R: Draft Final Report    F/R: Final Report

Source: JICA Study team

## CHAPTER 2

### CONFIRMATION OF VALIDITY AND NECESSITY OF THE PROJECT

#### 2.1 TRAFFIC RELATED PROJECTS IN METRO MANILA

##### (1) On-going Projects

Major on-going traffic projects in Metro Manila are as follows;

MMDA: 1. Installation of footbridges at five strategic locations in Metro Manila

DPWH: 1. One underpass project is under implementation (C-3/Quezon Ave. )

2. Three flyover projects are under tendering (C-2/R-7 Flyover, C-5/Lanuza-Julia Vargas Flyover and C-3/A. Bonifacio Flyover)

DOTC: 1. Construction of MRT-7 is under assessment by NEDA

##### (2) Projects Under Study

Major traffic projects under study in Metro Manila are as follows;

DPWH: 1. Five flyover projects by JICA (C-3/E. Rodriguez, EDSA/North/West/Mindanao, EDSA/Roosevelt/Congressional, C-5/Kalayaan and C-5/Green Meadows)

2. C-3 missing link by JICA

3. Daang Hari – SLEX Link proposed by private sector

4. NAIA Expressway (Phase II) proposed by private sector

5. C-5/FTI/Skyway Connector

6. C-6 Expressway North, South and Extension Section proposed by private sector

7. NLEX-SLEX Link Expressway proposed by private sector

DOTC: 1. LRT Line 2 Extension, East and West Section

2. LRT Line 1 Cavite Extension proposed by private sector

##### (3) Future Projects

Major future traffic projects in Metro Manila are as follows;

MMDA: 1. Establishment of the Mega Manila Provincial Integrated Bus Axis System (MM-PIBAS), North PIBAS Terminal, Development of Airport Tram System. Upgrading of Traffic Signal System and Field facilities, Photo Speed Enforcement System and Development of Alternative Mode of Transport

2. San Juan River Elevated Expressway

DPWH: 1. C-5 Improvement Project Segment A ~ D

2. R-7 Expressway

3. NLEX East/La Mesa Parkway

## **2.2 CONFIRMATION OF CONSISTENCY ON TRAFFIC PLANS BY OTHER AGENCIES**

This Project is consistent with the traffic plans of other agencies such as MMDA and DOTC. There is no conflict with traffic plan of other agencies; it is supportive of the traffic plans of the LGUs and other agencies. However, the following issues are to be noted:

### **MRT Line 7 Construction**

The proposed intersection scheme for EDSA/West/North/Mindanao Avenues has been confirmed and approved by the project proponent of MRT 7 and DOTC. However, a reconfirmation has to be made during the Detailed Design Stage to ensure that there has been no change in the scheme that has been originally approved.

### **Skyway Stage 3**

The project is a 14.5km six-lane elevated viaduct that will connect the north and south expressways via C-3, and has been approved as a priority project by the government. Correspondingly, implementation of the C-3/E. Rodriguez Interchange has been canceled by DPWH due to a conflict of its alignment with that of the project.

## **2.3 CONFIRMATION OF NECESSITY AND PRIORITY OF THE PROPOSED FLYOVER PROJECT**

The five interchange locations are included in the list of priority projects for NCR under DPWH's Public Investment Program 2011-2016. Proposed budget for the Metro Manila Interchange Construction Project is about P7.36 Billion. The construction of five interchanges has a total allocation of P5.17 Billion excluding consultancy services.

## **2.4 LESSONS LEARNED FROM PREVIOUS SIMILAR PROJECTS AND PROPOSED COUNTERMEASURES**

The ex-post evaluation study for Metro Manila Interchange Construction Project (IV) dated June 2008 was undertaken jointly by JBIC Consultants and the National Economic and Development Authority (NEDA). The Report identified following three lessons and recommended the action to be taken into account in future project implementation:

Lesson-1: Lack of in-depth investigation during detailed design

Lesson-2: Delay in land acquisition and resettlement

Lesson-3: Absence of pragmatic project scheduling

Recommendation: Sufficient maintenance fund should be secured

Consolidated Report in January 2011 for Metro Manila Urban Transport Integration Project (MMURTRIP) financed by the World Bank identified that bureaucratic processes, changes in administration, and ensuing changes in development policy are main causes of delay in project implementation.



## **2.5 CONFIRMATION OF PRESENT CONDITION AND FUTURE INVESTMENT PLAN FOR HIGHWAY SECTOR**

The DPWH Public Investment Plan (2011-2016) allocated 84% of the total investment program for highway sector and gets the biggest share. Of the P 698 Billion total investment requirement, P 586 Billion is earmarked for the highways sector.

## **2.6 CONFIRMATION OF ORGANIZATION, ANNUAL BUDGET AND TECHNICAL LEVEL OF THE DPWH MANDATE, FUNCTIONS, VISION AND MISSION**

### **2.6.1 Authority, Function, Vision and Mission of DPWH**

Following mottos are stated in the DPWH Public Investment Plan (2011~2016)

#### **Mandate**

The DPWH is one of the three government agencies tasked to develop social infrastructures and specifically mandated to undertake planning, design, construction and maintenance of national roads and bridges, flood control, water resources projects and other public works,

#### **Functions**

As the engineering and construction arm of the Government, the DPWH is tasked to continuously develop its technology for the purpose of ensuring the safety of all infrastructure facilities and securing for all public works and highways with the highest efficiency and quality in construction.

#### **Vision**

By 2030, DPWH is an effective and efficient government agency, improving the life of every Filipino through quality infrastructure.

#### **Mission**

To provide and manage quality infrastructure facilities and services responsive to the needs of the Filipino people in the pursuit of national development objectives.

### **2.6.2 Annual Budget**

DPWH budget for Fiscal Year (FY) 2012 is P 99.5 Billion where P 78.1 Billion is allocated (79%) for highway sector, and P 10.8 Billion (11%) for flood control, respectively.

### **2.6.3 Technical Level for Construction and Maintenance of Flyover of the DPWH**

Flyover construction is undertaken by the PMO-URPO and maintenance is by Regional Office of NCR. The technical level of both agencies is fairly high and capable of constructing and maintaining flyovers, but these is room for improvement in the following process.

1. Bureaucratic procurement process
2. Prolonged relocation process
3. Passive instead of preventive maintenance approach

## **2.7 CIRCUMSTANCES OF SUPPORT TO THE TRANSPORT SECTOR BY OTHER DONORS**

International funding institutions continuously support the Government in the implementation of transport projects in the form of loan, grant and technical assistance. Local funds are not sufficient to meet the funding requirements of transport projects.

Among the funding institutions, JICA has the biggest share of financing at 12.44% followed by France at 2.97%, World Bank at 2.20%, ADB at 1.95% , UK at 1.75%, Saudi Arabia at 0.39%, KEDCF at 0.76%, MCC at 0.12%, PROC at 0.17%, Kuwait at 0.49%, Spain at 0.49% and Australia at 0.10%.

## CHAPTER 3

### TRAFFIC FLOW ANALYSIS AND DEMAND FORECAST

#### 3.1 TRAFFIC SURVEY

##### 3.1.1 Type and Location of Traffic Survey

The traffic surveys shown in **Table 3.1-1** were conducted to grasp the present traffic flow characteristics of the project sites.

**Table 3.1-1 Type and Location of Traffic Surveys**

Type of Survey	Purpose of the Survey	Location
1. Intersection Directional Traffic Volume (Dec. 6~Dec. 21 2011)	- Assessment of present service level of the intersections - Formulation of interchange schemes - Benefit calculation	1. C-3/E. Rodriguez 2. DSA/Roosevelt/Congressional 3. DSA/North/West/Mindanao
2. Number Plate Vehicle Movement Survey (Dec. 6~Dec. 21 2011)	- Formulation of present Origin Destination (OD) matrix for traffic analyses	4. C-5/Kalayaan 5. C-5/Green Meadows/Acroplis /Calle Industria
3. Intersection Queue Length Survey (Dec. 6~Dec. 21 2011)	- Verification of current service level of the intersections	Note: C-5/Kalayaan is not included in the Number Plate Survey
4. Travel Speed Survey (Nov. 22~Dec.8 2011)	- Basic information for assessment of effect and impact of interchange construction	8 major streets passing/crossing project intersections

Source: JICA Study Team

Note: Survey of above 1, 2 and 3 of C-5/Kalayaan was conducted March 13 and 14 2012

Traffic flow direction, OD code, location of queue length survey and number plate survey at each intersection are shown in **Figures 3.1-1 to 3.1-5**.

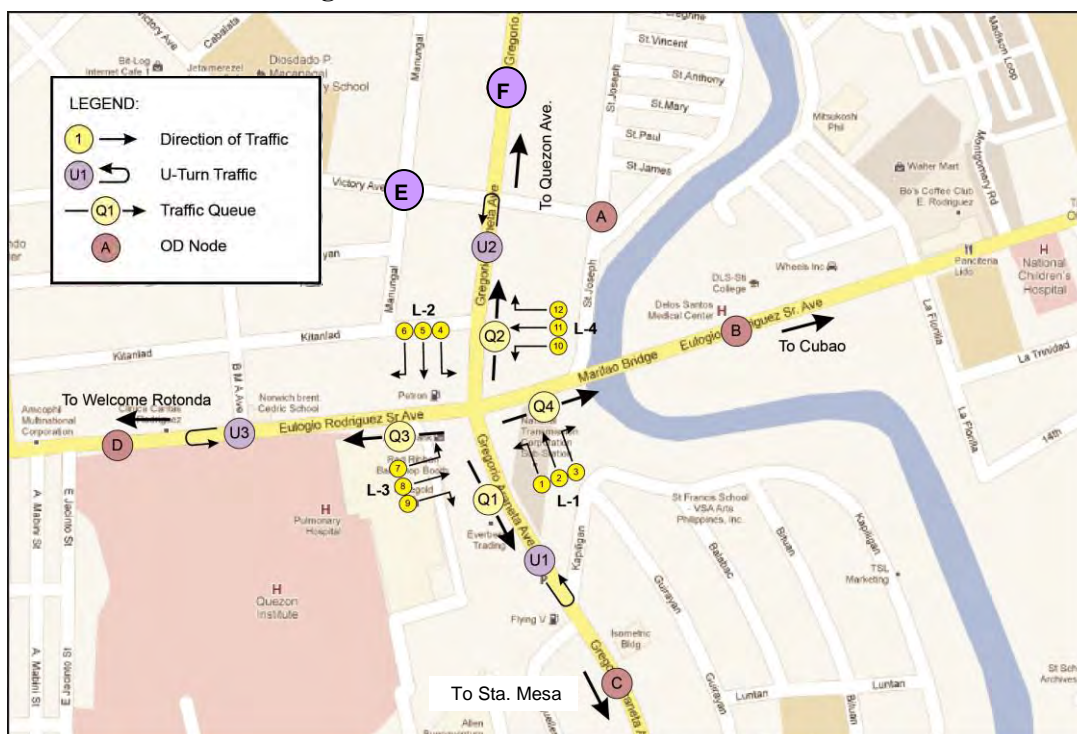

Source: JICA Study Team

**Figure 3.1-1 Traffic Survey Location at C-3/E. Rodriguez Intersection**

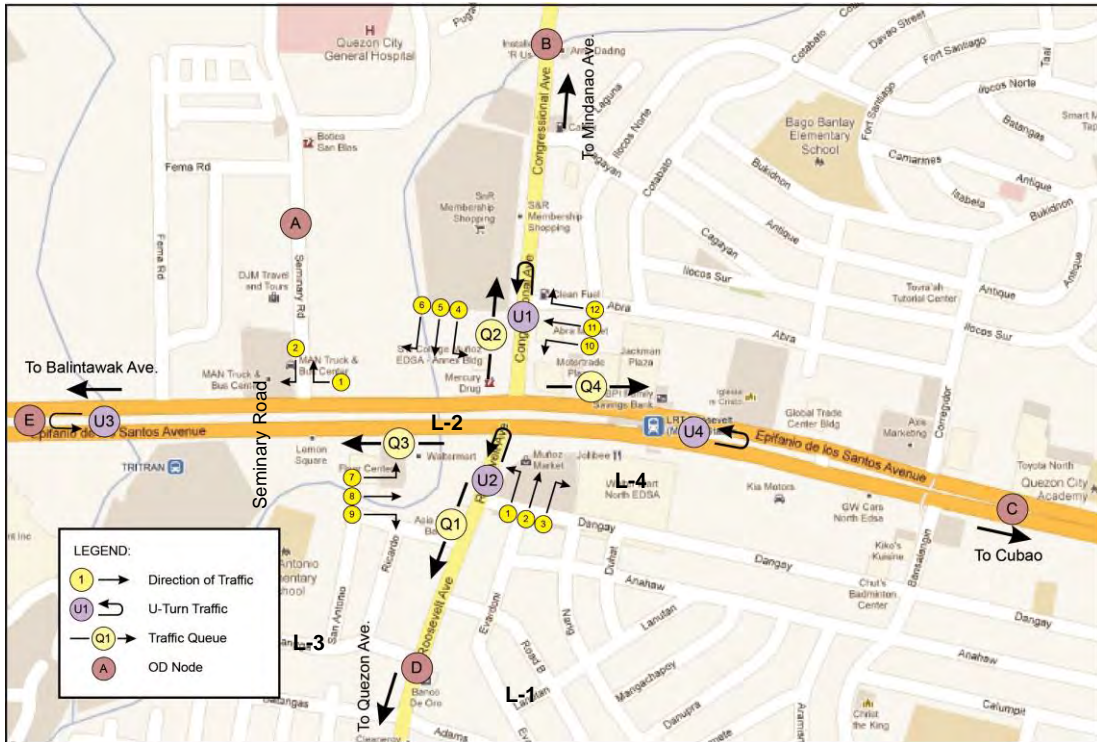

Source: JICA Study Team

Figure 3.1-2 Traffic Survey Location at EDSA/Roosevelt/Congressional Ave.

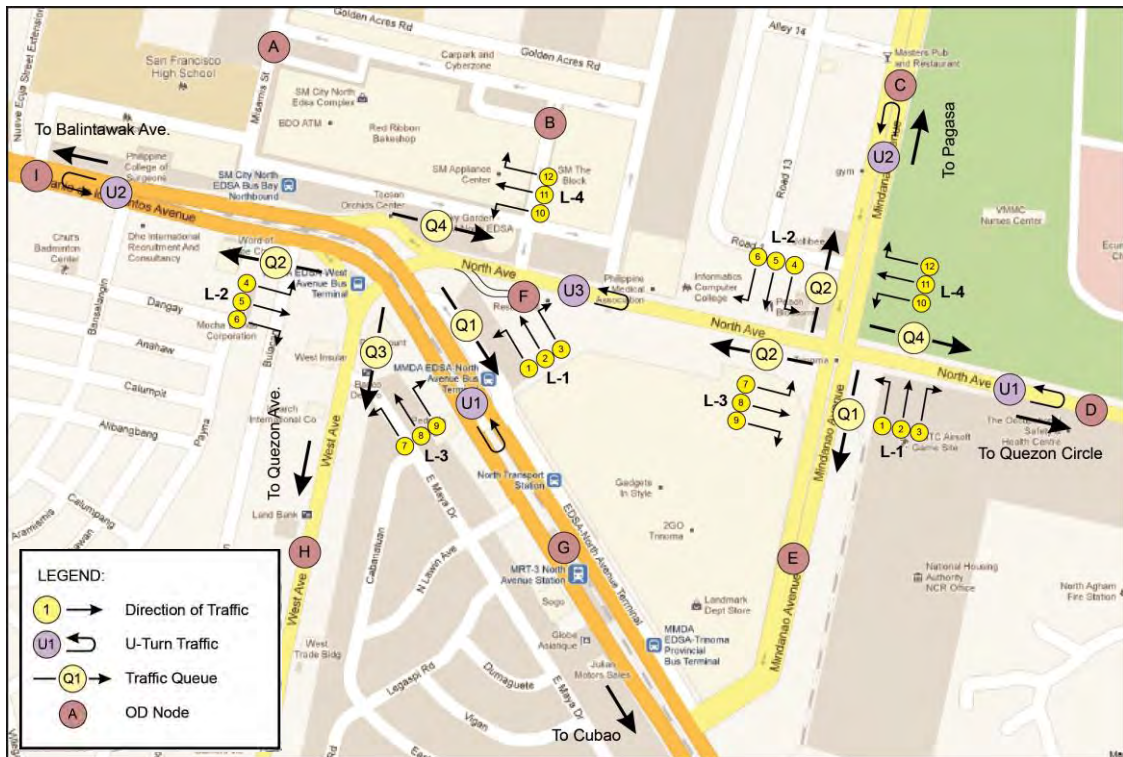

Source: JICA Study Team

Figure 3.1-3 Traffic Survey Location at EDSA/North/West/Mindanao Ave.



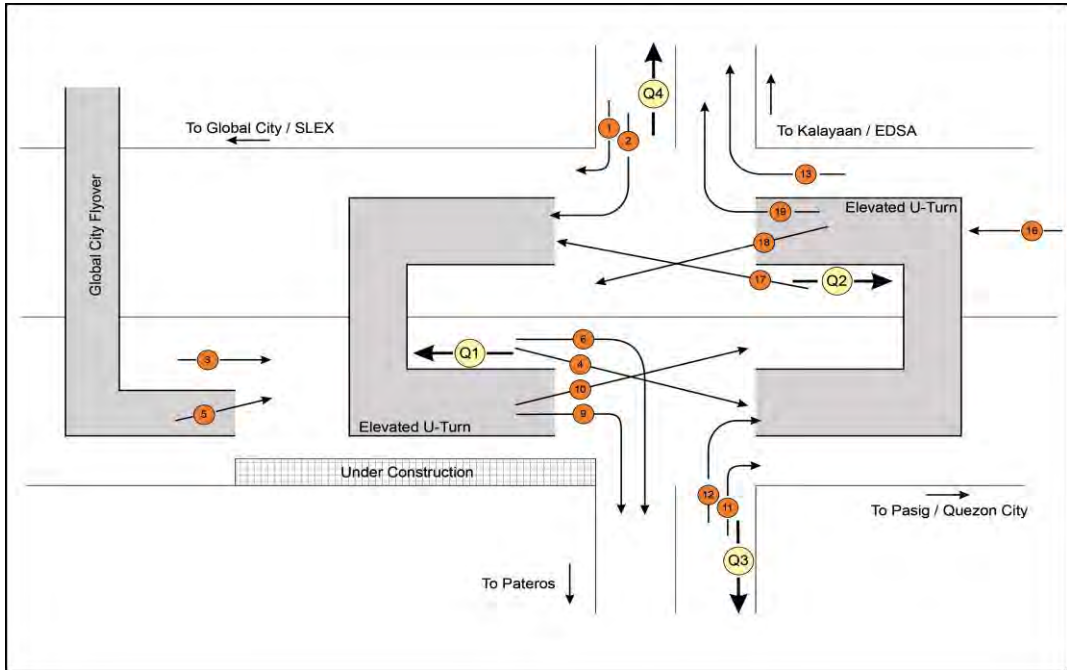

Source: JICA Study Team

Figure 3.1-4 Traffic Survey Location at C-5/Kalayaan Ave.



Source: JICA Study Team

Figure 3.1-5 Traffic Survey Location at C-5/Green Meadows

### 3.1.2 Result of Intersection Directional Traffic Volume Survey

Result of survey is summarized in Table 3.1-2~3.1-4

**Table 3.1-2 Intersection Traffic Volume (AADT) (1/3)**

Station Code	Flow No	Directional Flow		Vehicle Types										TOTAL
		From	To	Passenger Car	Passenger Jeepney	Goods Utility (Van)	Small Bus	Large Bus	Rigid 2-axle Truck	Rigid 3-axle or more Truck	Semi-Trailer Truck (3 or more axles)	Motorcycle	Tricycle	
<b>No.1 C-3/E. Rodriguez Intersection</b>														
<b>Leg-1: from Sta. Mesa along C-3</b>														
ITC-ER1	1	Sta. Mesa	Welcome	0	0	0	0	0	0	0	0	0	0	0
ITC-ER1	2	Sta. Mesa	Sgt. Rivera	22,340	1,092	1,620	10	52	853	492	361	4,881	572	32,272
ITC-ER1	3	Sta. Mesa	Cubao	5,013	23	281	4	9	99	10	42	958	63	6,501
<b>Sub-total</b>				<b>27,353</b>	<b>1,115</b>	<b>1,901</b>	<b>13</b>	<b>60</b>	<b>951</b>	<b>502</b>	<b>403</b>	<b>5,839</b>	<b>635</b>	<b>38,773</b>
<b>Leg-2: from Quezon Ave. along C-3</b>														
ITC-ER1	4	Quezon Ave.	Cubao	0	0	0	0	0	0	0	0	0	0	0
ITC-ER1	5	Quezon Ave.	Sta. Mesa	12,239	1,105	2,310	2	15	966	253	166	6,991	780	24,826
ITC-ER1	6	Quezon Ave.	Welcome	2,290	60	231	0	4	48	8	3	547	40	3,233
<b>Sub-total</b>				<b>14,529</b>	<b>1,165</b>	<b>2,541</b>	<b>2</b>	<b>19</b>	<b>1,013</b>	<b>261</b>	<b>169</b>	<b>7,538</b>	<b>820</b>	<b>28,059</b>
<b>Leg-3: from Welcome along E. Rodriguez</b>														
ITC-ER1	7	Welcome	Sgt. Rivera	0	0	0	0	0	0	0	0	0	0	0
ITC-ER1	8	Welcome	Cubao	13,424	2,837	1,014	1	80	151	4	4	3,393	0	20,908
ITC-ER1	9	Welcome	Sta. Mesa	5,243	26	748	2	9	163	42	23	613	40	6,907
<b>Sub-total</b>				<b>18,667</b>	<b>2,863</b>	<b>1,762</b>	<b>2</b>	<b>90</b>	<b>314</b>	<b>46</b>	<b>26</b>	<b>4,006</b>	<b>40</b>	<b>27,815</b>
<b>Leg-4: from Cubao along E. Rodriguez</b>														
ITC-ER1	10	Cubao	Sta. Mesa	0	0	0	0	0	0	0	0	0	0	0
ITC-ER1	11	Cubao	Welcome	17,598	2,760	1,445	0	117	347	14	6	3,306	74	25,667
ITC-ER1	12	Cubao	Sgt. Rivera	3,318	30	546	4	5	172	48	20	1,055	79	5,276
<b>Sub-total</b>				<b>20,916</b>	<b>2,790</b>	<b>1,991</b>	<b>4</b>	<b>122</b>	<b>519</b>	<b>62</b>	<b>25</b>	<b>4,361</b>	<b>153</b>	<b>30,943</b>
<b>U-Trun Traffic</b>		Name of Street	Location											
UTC-ER1	1	C-3	Sta. Mesa U-Turn	2,483	66	414	3	8	134	23	6	633	157	3,926
UTC-ER1	2	C-3	Sgt. Rivera U-Turn	4,712	91	750	1	7	166	38	11	551	79	6,405
UTC-ER1	3	E. Rodriguez	Q.I. U-Turn	2,089	86	196	2	1	48	1	0	192	23	2,636
<b>No.2 EDSA/Roosevelt/Congressional Intersection</b>														
<b>Leg-1: from Quezon Ave. along Roosevelt Ave.</b>														
ITC-ERC1	1	Quezon Ave.	Balintawak	0	0	0	0	0	0	0	0	0	0	0
ITC-ERC1	2	Quezon Ave.	Mindanao Ave.	0	0	0	0	0	0	0	0	0	0	0
ITC-ERC1	3	Quezon Ave.	Cubao	5,278	2,068	1,062	0	4	340	54	0	2,771	18	11,597
<b>Sub-total</b>				<b>5,278</b>	<b>2,068</b>	<b>1,062</b>	<b>0</b>	<b>4</b>	<b>340</b>	<b>54</b>	<b>0</b>	<b>2,771</b>	<b>18</b>	<b>11,597</b>
<b>Leg-2: from Mindanao Ave. along Congressional Ave.</b>														
ITC-ERC1	4	Mindanao Ave.	Cubao	0	0	0	0	0	0	0	0	0	0	0
ITC-ERC1	5	Mindanao Ave.	Quezon Ave.	0	0	0	0	0	0	0	0	0	0	0
ITC-ERC1	6	Mindanao Ave.	Balintawak	14,280	2,360	1,376	1	842	984	313	74	3,753	7	23,990
<b>Sub-total</b>				<b>14,280</b>	<b>2,360</b>	<b>1,376</b>	<b>1</b>	<b>842</b>	<b>984</b>	<b>313</b>	<b>74</b>	<b>3,753</b>	<b>7</b>	<b>23,990</b>
<b>Leg-3: from Balintawak along EDSA</b>														
ITC-ERC1	7	Balintawak	Mindanao Ave.	0	0	0	0	0	0	0	0	0	0	0
ITC-ERC1	8	Balintawak	Cubao	33,768	2,495	5,026	1	5,086	2,694	1,235	780	5,456	7	56,550
ITC-ERC1	9	Balintawak	Quezon Ave.	4,045	2,136	799	1	3	198	32	27	2,462	0	9,702
<b>Sub-total</b>				<b>37,813</b>	<b>4,631</b>	<b>5,825</b>	<b>2</b>	<b>5,089</b>	<b>2,892</b>	<b>1,267</b>	<b>808</b>	<b>7,919</b>	<b>7</b>	<b>66,252</b>
<b>Leg-4: from Cubao along EDSA</b>														
ITC-ERC1	10	Cubao	Quezon Ave.	0	0	0	0	0	0	0	0	0	0	0
ITC-ERC1	11	Cubao	Balintawak	33,340	2,930	3,891	22	4,310	2,352	527	179	4,600	0	52,149
ITC-ERC1	12	Cubao	Mindanao Ave.	12,325	2,228	1,692	0	750	601	88	13	3,152	8	20,858
<b>Sub-total</b>				<b>45,665</b>	<b>5,158</b>	<b>5,582</b>	<b>22</b>	<b>5,060</b>	<b>2,953</b>	<b>615</b>	<b>192</b>	<b>7,752</b>	<b>8</b>	<b>73,007</b>
<b>Name of Intersection: EDSA/Seminary Road</b>														
ITC-ERC2	1	EDSA	Seminary Road	1,425	55	152	0	0	51	4	0	339	33	2,059
ITC-ERC2	2	Seminary Road	EDSA	2,218	188	385	0	11	163	10	4	685	2	3,665
<b>Sub-total</b>				<b>3,643</b>	<b>243</b>	<b>537</b>	<b>0</b>	<b>11</b>	<b>214</b>	<b>14</b>	<b>4</b>	<b>1,024</b>	<b>35</b>	<b>5,724</b>
<b>U-Turn Traffic</b>		Name of Street	Location											
UTC-ERC1	1	Congressional Ave.	Congressional U-Turn	16	970	4	1	0	1	0	0	26	10	1,027
UTC-ERC1	2	Roosevelt Ave.	at intersection	177	4	20	2	0	2	0	0	43	1	250
UTC-ERC1	3	EDSA	Balintawak U-Turn	7,042	2,591	730	0	955	353	26	0	2,727	0	14,424
UTC-ERC1	4	EDSA	In front of Inc U-Turn	9,802	3,709	1,803	5	15	838	64	12	4,421	0	20,670

Source: JICA Study Team

**Table 3.1-3 Intersection Traffic Volume (AADT) (2/3)**

No 3A EDSA/North/West Intersection															
Leg-1: from Cubao along EDSA															
ITC-SM1															
ITC-SM1	1	Cubao	Quezon Ave.	0	0	0	0	0	0	0	0	0	0	0	
ITC-SM1	2	Cubao	Balintawak	100,058	1,070	2,618	0	6,864	2,993	278	60	4,629	0	118,571	
ITC-SM1	3	Cubao	Quezon Circle	23,994	3,443	1,897	3	8	615	92	6	3,669	0	33,727	
<b>Sub-total</b>				<b>124,052</b>	<b>4,513</b>	<b>4,515</b>	<b>3</b>	<b>6,873</b>	<b>3,608</b>	<b>369</b>	<b>67</b>	<b>8,298</b>	<b>0</b>	<b>152,298</b>	
Leg-2: from Balintawak along EDSA															
ITC-SM1	4	Balintawak	Quezon Circle	0	0	0	0	0	0	0	0	0	0	0	
ITC-SM1	5	Balintawak	Cubao	47,524	2,270	5,091	16	5,026	3,360	1,524	1,159	8,637	0	74,607	
ITC-SM1	6	Balintawak	Quezon Ave.	10,368	2,174	744	11	9	186	12	0	1,360	2	14,864	
<b>Sub-total</b>				<b>57,892</b>	<b>4,443</b>	<b>5,835</b>	<b>28</b>	<b>5,035</b>	<b>3,545</b>	<b>1,536</b>	<b>1,159</b>	<b>9,997</b>	<b>2</b>	<b>89,471</b>	
Leg-3: from Quezon Ave. along West Ave.															
ITC-SM1	7	Quezon Ave.	Balintawak	0	0	0	0	0	0	0	0	0	0	0	
ITC-SM1	8	Quezon Ave.	Quezon Ave.	0	0	0	0	0	0	0	0	0	0	0	
ITC-SM1	9	Quezon Ave.	Cubao	8,913	2,053	616	0	0	0	2	0	1,543	0	13,126	
<b>Sub-total</b>				<b>8,913</b>	<b>2,053</b>	<b>616</b>	<b>0</b>	<b>0</b>	<b>0</b>	<b>2</b>	<b>0</b>	<b>1,543</b>	<b>0</b>	<b>13,126</b>	
Leg-4: from Quezon Circle along North Ave.															
ITC-SM1	10	Quezon Circle	Cubao	0	0	0	0	0	0	0	0	0	0	0	
ITC-SM1	11	Quezon Circle	Quezon Ave.	0	0	0	0	0	0	0	0	0	0	0	
ITC-SM1	12	Quezon Circle	Balintawak	16,164	2,808	987	0	4	467	174	72	2,639	1	23,316	
<b>Sub-total</b>				<b>16,164</b>	<b>2,808</b>	<b>987</b>	<b>0</b>	<b>4</b>	<b>467</b>	<b>174</b>	<b>72</b>	<b>2,639</b>	<b>1</b>	<b>23,316</b>	
U-Trun Traffic		Name of Street	Location												
UTC-SM1	1	EDSA	Trinoma U-Turn	16,512	3,210	2,216	1	12	308	85	24	2,822	0	25,190	
UTC-SM1	2	EDSA	SM Annex U-Turn	16,382	2,100	894	2	14	367	34	5	2,158	2	21,957	
UTC-SM1	3	North Avenue	SM U-Turn	7,408	2,910	520	3	0	8	2	0	404	11	11,266	
Station Code	Flow No	Directional Flow		Vehicle Types											
		From	To	Passenger Car	Passenger Jeepney	Goods Utility (Van)	Small Bus	Large Bus	Rigid 2-axle Truck	Rigid 3-axle or more Truck	Semi-Trailer Truck (3 or more axles)	Motorcycle	Tricycle	TOTAL	
No. 3B North Ave./Mindanao Ave. Intersection															
Leg-1: from Trinoma along Mindanao Ave. Ext.															
ITC-M1	1	Trinoma	EDSA	0	0	0	0	0	0	0	0	0	0	0	
ITC-M1	2	Trinoma	Pagasa	0	0	0	0	0	0	0	0	0	0	0	
ITC-M1	3	Trinoma	Quezon Circle	6,958	0	254	3	1	120	2	0	596	0	7,934	
<b>Sub-total</b>				<b>6,958</b>	<b>0</b>	<b>254</b>	<b>3</b>	<b>1</b>	<b>120</b>	<b>2</b>	<b>0</b>	<b>596</b>	<b>0</b>	<b>7,934</b>	
Leg-2: from Pagasa along Mindanao Ave.															
ITC-M1	4	Pagaasa	Quezon Circle	8,229	40	1,373	1	24	1,050	1,548	375	4,480	226	17,344	
ITC-M1	5	Pagaasa	Trinoma	8,682	0	526	0	1	56	3	0	1,027	0	10,296	
ITC-M1	6	Pagaasa	EDSA	5,672	3,441	705	1	4	222	6	18	1,336	0	11,404	
<b>Sub-total</b>				<b>14,354</b>	<b>3,441</b>	<b>1,232</b>	<b>1</b>	<b>5</b>	<b>278</b>	<b>9</b>	<b>18</b>	<b>2,363</b>	<b>0</b>	<b>21,700</b>	
Leg-3: from EDSA along North Ave.															
ITC-M1	7	EDSA	Pagasa	14,590	4,542	1,400	10	5	410	24	0	1,948	0	22,929	
ITC-M1	8	EDSA	Quezon Circle	8,601	1,914	1,218	3	13	646	134	28	1,596	0	14,153	
ITC-M1	9	EDSA	Trinoma	6,257	0	386	0	1	4	0	0	357	0	7,005	
<b>Sub-total</b>				<b>14,858</b>	<b>1,914</b>	<b>1,603</b>	<b>3</b>	<b>14</b>	<b>650</b>	<b>134</b>	<b>28</b>	<b>1,953</b>	<b>0</b>	<b>21,158</b>	
Leg-4: from Quezon Circle along North Ave.															
ITC-M1	10	Quezon Circle	Trinoma	3,318	0	79	0	0	12	0	0	229	0	3,637	
ITC-M1	11	Quezon Circle	EDSA	8,286	2,312	530	1	20	360	171	67	2,153	0	13,901	
ITC-M1	12	Quezon Circle	Pagasa	6,685	94	799	16	7	995	1,097	627	3,256	266	13,843	
<b>Sub-total</b>				<b>14,971</b>	<b>2,405</b>	<b>1,330</b>	<b>17</b>	<b>28</b>	<b>1,355</b>	<b>1,268</b>	<b>694</b>	<b>5,410</b>	<b>266</b>	<b>27,744</b>	
U-Turn Traffic		Name of Street	Location												
UTC-M1	U 1	North Ave.	Mindanao Ave. U-Turn	748	412	53	1	1	21	2	2	201	211	1,651	
UTC-M1	U 2	North Ave.	VMMC U-Turn	415	62	1	0	0	0	0	0	20	0	499	

Source: JICA Study Team

**Table 3.1-4 Intersection Traffic Volume (AADT) (3/3)**

Station Code	Flow No	Directional Flow		Vehicle Types										TOTAL
		From	To	Passenger Car	Passenger Jeepney	Goods Utility (Van)	Small Bus	Large Bus	Rigid 2-axle Truck	Rigid 3-axle or more Truck	Semi-Trailer Truck (3 or more axles)	Motorcycle	Tricycle	
<b>No. 4 C-5/Kalayaan Intersection</b>														
<b>Leg-1: from EDSA along Kalayaan</b>														
ITC-K	1	EDSA	Global/SLEX	1,116	2,161	130	1	11	71	78	6	636	0	4,209
ITC-K	2	EDSA	Elevated U-Turn	11,507	870	1,042	1	8	707	384	82	3,744	0	18,344
<b>Sub-total</b>				<b>12,623</b>	<b>3,031</b>	<b>1,172</b>	<b>1</b>	<b>19</b>	<b>778</b>	<b>461</b>	<b>88</b>	<b>4,379</b>	<b>0</b>	<b>22,552</b>
<b>Leg-2: from Global/SLEX along C-5</b>														
ITC-K	3	Global/SLEX	Pasig/Quezon City	35,418	2,813	4,800	15	117	3,096	2,450	902	12,762	0	62,372
ITC-K	5	Global/SLEX	Pasig/Quezon City	5,615	243	302	2	1	3	29	3	1,157	0	7,354
<b>Sub-total</b>				<b>44,512</b>	<b>3,879</b>	<b>5,549</b>	<b>17</b>	<b>140</b>	<b>3,402</b>	<b>3,048</b>	<b>964</b>	<b>15,164</b>	<b>0</b>	<b>76,674</b>
<b>Leg-3: from Pateros along Kalayaan Ave.</b>														
ITC-K	11	Pateros	Pasig/Quezon City	4,232	0	259	1	0	216	237	92	2,016	0	7,054
ITC-K	12	Pateros	Elevated U-Turn	4,282	820	623	2	10	338	310	166	2,424	0	8,973
<b>Sub-total</b>				<b>8,514</b>	<b>820</b>	<b>882</b>	<b>3</b>	<b>10</b>	<b>554</b>	<b>547</b>	<b>258</b>	<b>4,440</b>	<b>0</b>	<b>16,027</b>
<b>Leg-4: from Pasig/Quezon City along C-5</b>														
ITC-K	13	Pasig/Quezon City	EDSA	10,171	0	833	3	21	338	223	3	5,013	0	16,604
ITC-K	16	Pasig/Quezon City	Global/SLEX	39,255	0	4,268	19	62	3,164	2,257	851	10,382	0	60,257
<b>Sub-total</b>				<b>49,426</b>	<b>0</b>	<b>5,101</b>	<b>22</b>	<b>83</b>	<b>3,502</b>	<b>2,480</b>	<b>854</b>	<b>15,394</b>	<b>0</b>	<b>76,861</b>
<b>U-Turn Viaduct - 1 (South)</b>														
ITC-K	9	Elevated U-Turn	Pateros	6,765	628	761	0	0	333	391	84	2,225	0	11,187
ITC-K	10	Elevated U-Turn	Pasig/Quezon City	7,905	0	1,090	0	6	677	221	431	2,526	0	12,856
<b>Sub-total</b>				<b>14,670</b>	<b>628</b>	<b>1,851</b>	<b>0</b>	<b>6</b>	<b>1,011</b>	<b>611</b>	<b>514</b>	<b>4,751</b>	<b>0</b>	<b>24,043</b>
<b>U-Turn Viaduct - 2 (North)</b>														
ITC-K	18	Elevated U-Turn	Global/SLEX	4,582	93	306	1	9	301	240	92	2,087	0	7,713
ITC-K	19	Elevated U-Turn	EDSA	5,552	3,230	363	5	1	216	158	8	1,758	0	11,291
<b>Sub-total</b>				<b>10,134</b>	<b>3,323</b>	<b>669</b>	<b>6</b>	<b>10</b>	<b>518</b>	<b>398</b>	<b>100</b>	<b>3,845</b>	<b>0</b>	<b>19,004</b>
<b>Under U-Turn Viaduct</b>														
ITC-K	6	Global/SLEX	Pateros	3,479	823	447	1	23	302	569	60	1,245	0	6,949
ITC-K	4	Global/SLEX	Elevated U-Turn	5,893	2,053	112	0	1	197	44	1	1,327	0	9,627
ITC-K	17	Pasig/Quezon City	Elevated U-Turn	3,678	0	812	0	1	311	318	81	1,587	0	6,789
<b>No. 5 C-5/Greem Meadows/Acropolis/Calle Industria Intersections</b>														
<b>Leg-1: from Pasig along C-5</b>														
ITC-G1	1	Pasig	Greem Meadows	0	0	0	0	0	0	0	0	0	0	0
ITC-G1	2	Pasig	Eastwood	36,880	2,075	9,118	19	72	4,005	1,927	884	13,298	0	68,279
<b>Sub-total</b>				<b>36,880</b>	<b>2,075</b>	<b>9,118</b>	<b>19</b>	<b>72</b>	<b>4,005</b>	<b>1,927</b>	<b>884</b>	<b>13,298</b>	<b>0</b>	<b>68,279</b>
<b>Leg-2: from Cubao along C-5</b>														
ITC-G1	3	Calle Industrial	Pasig	47,509	2,216	6,020	11	114	3,122	1,750	597	12,696	0	74,035
ITC-G1	4	C5	Greem Meadows	6,903	0	550	0	1	7	12	1	1,319	0	8,792
<b>Sub-total</b>				<b>54,411</b>	<b>2,216</b>	<b>6,570</b>	<b>11</b>	<b>115</b>	<b>3,128</b>	<b>1,761</b>	<b>598</b>	<b>14,015</b>	<b>0</b>	<b>82,826</b>
<b>Leg-3: from Ortigas along Green Meadows</b>														
ITC-G1	5	Greem Meadows	Eastwood	0	0	0	0	0	0	0	0	0	0	0
ITC-G1	6	Greem Meadows	C5	7,355	0	187	6	1	1	4	0	959	0	8,513
<b>Sub-total</b>				<b>7,355</b>	<b>0</b>	<b>187</b>	<b>6</b>	<b>1</b>	<b>1</b>	<b>4</b>	<b>0</b>	<b>959</b>	<b>0</b>	<b>8,513</b>
<b>Leg-4: from Cainta along Calle Industria</b>														
ITC-G2	7	C5	Calle Industrial	7,830	308	1,072	5	14	486	168	85	2,929	2	12,900
ITC-G2	8	Calle Industrial	C5	6,136	325	1,346	0	11	585	406	179	2,637	2	11,627
<b>Sub-total</b>				<b>13,966</b>	<b>633</b>	<b>2,419</b>	<b>5</b>	<b>25</b>	<b>1,071</b>	<b>575</b>	<b>263</b>	<b>5,566</b>	<b>5</b>	<b>24,527</b>
<b>Leg-5: from Acropolis along Poseidon</b>														
ITC-G3	9	C5	Acropolis	1,075	0	81	0	1	11	1	0	186	0	1,355
ITC-G3	10	Acropolis	C5	1,066	0	124	0	0	4	0	0	205	0	1,399
<b>Sub-total</b>				<b>2,141</b>	<b>0</b>	<b>205</b>	<b>0</b>	<b>1</b>	<b>15</b>	<b>1</b>	<b>0</b>	<b>391</b>	<b>0</b>	<b>2,754</b>
<b>Leg-6: from Global One along Eastwood Ave.</b>														
ITC-G4	11	C5	Eastwood	7,414	0	200	6	16	2	0	0	1,045	0	8,681
ITC-G4	12	Eastwood	C5	9,817	0	266	0	2	0	0	0	1,010	0	11,096
<b>Sub-total</b>				<b>17,231</b>	<b>0</b>	<b>466</b>	<b>6</b>	<b>18</b>	<b>2</b>	<b>0</b>	<b>0</b>	<b>2,055</b>	<b>0</b>	<b>19,777</b>
<b>U-Trun Traffic</b>		Name of Street	Location											
UTC-G1	1	Eastwood	Greem Meadows U-Turn	8,412	282	823	2	2	87	0	1	1,082	2	10,693
UTC-G2	2	Pasig	Eastwood U-Turn	16,424	25	930	0	0	1	0	0	2,105	0	19,486

Source: JICA Study Team



### 3.2 CURRENT TRAFFIC CONDITION OF EACH INTERSECTION

Current condition of each intersection is summarized in **Table 3.2-1**.

**Table 3.2-1 Summary of Current Condition of Intersections**

<p><b>1. C-3/E. Rodriguez Intersection</b></p> <p><b>1.1 Traffic Control</b></p> <ul style="list-style-type: none"> <li>Traffic flow of the intersection is currently controlled by traffic signal with prohibited left turn movements from all directions.</li> <li>Three U-Turn slots are installed at the intersection; two slots along C-3 and one slot along E. Rodriguez in front of Quezon Institute.</li> </ul> <p><b>1.2 Traffic Volume</b></p> <ul style="list-style-type: none"> <li>Major traffic movements are;                     <ul style="list-style-type: none"> <li>OD (B⇌D) Cubao ⇌ Welcome with 8,340/6,234 vehicles/6 hours along E. Rodriguez.</li> <li>OD (F⇌C) Sta. Mesa ⇌ Quezon Avenue with 6,978/6,930 vehicles/6 hours along C-3.</li> </ul> </li> </ul> <p><b>1.3 Traffic Congestion</b></p> <ul style="list-style-type: none"> <li>Queue length along E. Rodriguez is longer than C-3</li> <li>Average travel speed along C-3 and E. Rodriguez that pass through the intersection is approximately 15km/hour during morning, noon time and afternoon peak hours.</li> </ul>
<p><b>2. EDSA/Roosevelt/Congressional Intersection</b></p> <p><b>2.1 Traffic Control</b></p> <ul style="list-style-type: none"> <li>There is no traffic signal control at the intersection. Straight and left turn movements along Roosevelt and Congressional Avenue are prohibited. Left turn movement along EDSA is also prohibited.</li> <li>Straight and left turn movements at the intersection will be hampered by pier of LRT viaduct that was constructed at center of the intersection</li> </ul> <p><b>2.2 Traffic Volume</b></p> <ul style="list-style-type: none"> <li>Major traffic movements are;                     <ul style="list-style-type: none"> <li>OD (C⇌E) Cubao ⇌ Balintawak with 10,050/11,743 vehicles/6 hours along EDSA,</li> <li>OD (B→E) Mindanao Ave. → Balintawak with 5,840 vehicles/6 hours, and</li> <li>OD (C→B) Cubao → Mindanao Ave. with 5,096 vehicles/6 hours.</li> </ul> </li> </ul> <p><b>2.3 Traffic Congestion</b></p> <ul style="list-style-type: none"> <li>Severe congestion is observed during afternoon peak hours. Queue length along southbound EDSA has reached 400m.</li> </ul>
<p><b>3. EDSA/North/West/Mindanao Ave. Intersection</b></p> <p><b>3.1 Traffic Control</b></p> <p><b><u>EDSA/North/West Avenue Intersection</u></b></p> <ul style="list-style-type: none"> <li>Traffic of the intersection is not controlled by traffic signal now. Straight and left turn movements along North Avenue and West Avenue are prohibited. Left turn movement along EDSA is also prohibited.</li> </ul> <p><b><u>North/Mindanao Avenue Intersection</u></b></p> <ul style="list-style-type: none"> <li>Traffic of the intersection is not controlled by traffic signal now. Straight and left turn movements along North Avenue and West Avenue are prohibited. Left turn movement along EDSA is also prohibited.</li> </ul> <p><b>3.2 Traffic Volume</b></p> <p><b><u>EDSA/North/West Avenue Intersection</u></b></p> <ul style="list-style-type: none"> <li>In addition to EDSA, traffic volume along North Avenue is also large and construction of additional viaduct along North Avenue was proposed by previous detailed design</li> <li>Construction of simple flyover along EDSA may be the most suitable flyover Scheme for the intersection.</li> </ul>

<p><b><u>North/Mindanao Avenue Intersection</u></b></p> <ul style="list-style-type: none"> <li>Left turn traffic between North Avenue and Mindanao Avenue is major traffic flow rather than straight traffic at this intersection.</li> </ul>
<p><b>3.3 Traffic Congestion</b></p> <ul style="list-style-type: none"> <li>Severe traffic congestion along EDSA northbound during afternoon peak hours is observed. Queue length along northbound EDSA reaches 400m during afternoon peak hours.</li> </ul>
<p><b>4. C-5/Kalayaan Intersection</b></p>
<p><b>4.1 Traffic Control</b></p> <ul style="list-style-type: none"> <li>There is no traffic signal control at the intersection. Straight and left turn movements along Kalayaan Avenue are prohibited. Left turn movement from C-5 is also prohibited.</li> <li>There are two U-Turn viaducts along C-5.</li> </ul>
<p><b>4.2 Traffic Volume</b></p> <ul style="list-style-type: none"> <li>Major traffic movements are straight flow along C-5 (AADT 118,514 from Global/SLEX and AADT 133,317 from/to Pasig/Quezon City).</li> </ul>
<p><b>4.3 Traffic Congestion</b></p> <ul style="list-style-type: none"> <li>Queue length along C-5 reaches 400m along northbound lane in the afternoon peak and 305m along southbound lane in the morning peak.</li> <li>The intersection may be saturated in the near future.</li> </ul>
<p><b>5. C-5/Green Meadows/Acropolis/Calle Industria</b></p>
<p><b>5.1 Traffic Control</b></p> <ul style="list-style-type: none"> <li>Intersections are not controlled by traffic signal but restriction movements. All left turn movements are prohibited at each intersection.</li> </ul>
<p><b>5.2 Traffic Volume</b></p> <ul style="list-style-type: none"> <li>Major traffic movements are through traffic along C-5 and other traffic movements from/to other streets are marginal.</li> <li>The substantial number of traffic may be eliminated from at-grade intersection if through traffic flyover will be constructed.</li> </ul>
<p><b>5.3 Traffic Congestion</b></p> <ul style="list-style-type: none"> <li>Severe traffic congestion is experienced along C-5 due to merging traffic from side streets. Queue length at C-5/Green Meadows reaches more than 200m during morning and afternoon peak hours.</li> </ul>

Source: JICA Study Team

### 3.3 TRAFFIC DEMAND FORECAST

The traffic demand forecast for four intersections, namely C-3/E. Rodriguez, EDSA/ Roosevelt/ Congressional Ave., EDSA/North/West/Mindanao and C-5/Green Meadows/Acropolis/Calle Industria have been carried out till 2018, the expected opening year of the interchanges, and till 2028, 10 years after opening the interchanges.

#### 3.3.1 The Methodology of the Demand Forecast

The traffic demand forecast was undertaken by the following two steps:

**Step 1:** Estimation of traffic volume growth rate considering future road network in Metro Manila

Traffic growth rate at each intersection was estimated through analysis on overall traffic flow in Metro Manila considering the future road network development plan proposed by MMUTIS. The result of the analysis was used to forecast future traffic volume at each intersection.

**Step 2:** Traffic analysis at the intersections by micro-simulation

Micro-simulation at each intersection was carried out using present traffic count data and the growth rates derived in the Step 1.

#### (1) Estimation of Traffic Growth Rate

The estimated traffic growth rate used in traffic analysis is shown in **Table 3.3-1**.

**Table 3.3-1 Average Traffic Growth Rate for the Project**

Period	Annual Growth Rate
2011-2015	6.4%
2015-2020	4.5% (-1.9%)
2020-2028	3.7% (-0.8%)

Source: JICA Study Team

#### (2) Road Network Data

**2011 Road Network:** The 1996 MMUTIS road network was used for analysis of 2011 traffic since no major changes of the network was reported.

**2018 Road Network:** The “C-3 Missing Link” is to be added to the 2011 road network for the 2018 road network.

**2028 Road Network:** The MMUTIS master plan road network is used as the 2028 road network.

#### (3) Traffic Volume Growth Ratio at Each Intersection

Traffic volume growth ratio of each intersection is shown in **Table 3.3-2**.

**Table 3.3-2 Traffic Growth Ratio at Each Intersection**

Period	Traffic Volume Growth Ratio				Vehicle Type
	C-3/E. Rodriguez	EDSA/Roosevelt	EDSA/North/West	C-5/Green Meadows	
2018/2011	1.96	1.27	1.27	1.15	All Type
2028/2018	1.62	1.31	1.31	1.48	Motor Cycle, Jeepney
2028/2018	0.64	0.93	0.93	1.48	Car, Utility Vehicle, Bus, Truck

Source: JICA Study Team

**(4) Traffic Analysis at Intersections with Micro-simulation**

Analysis of intersection improvement is carried out by micro-simulation with the following procedures.

- 1. Establishment of OD matrices for the micro-simulation :** Current OD matrices for micro-simulation of intersections are established considering the results of traffic surveys. OD matrices of AM peak hour, mid noon off peak and PM peak hour. The three hour traffic volume was expanded to 24 hour by multiplying expansion factors.
- 2. Formulation of Present Network :** Present intersection network is formulated based on the result of site survey, topographic survey and existing road inventory data.
- 3. Future OD Matrices :** Future OD matrices are established using the growth ratio that was calculated using a model based on MMUTIS.
- 4. Future Network :** Two future networks were established; one is “without project network” that is basically same as the current network and “with project network” that incorporates proposed flyovers.
- 5. Micro-simulation :** Micro-simulation was carried out with the future OD matrices and networks. The software package for micro-simulation is VISSIM. It is one of the software packages for Traffic Simulation authorized by the clearing house group managed by Japan Society of Traffic Engineers.

**3.3.2 Result of Traffic Demand Forecast by Micro-simulation**

Daily vehicle-km, daily-vehicle hour and average travel speed of each interchange are shown in **Tables 3.3-3 to 3.3-6.**

**Table 3.3-3 Daily Vehicle-Km, Vehicle-Hour and Average Travel Speed  
(C-3/E. Rodriguez Intersection)**

Indicator	Vehicle Category	2011 (Daily)	2018 (Daily)			2028 (Daily)		
			2018 (With)	2018 (Without)	With - Without	2028 (With)	2028 (Without)	With - Without
Vehicle Km	Car	90,049	174,597	175,989	-1,392	111,650	112,375	-724
	Jeepney	9,346	18,453	18,432	20	30,503	30,529	-26
	Utility Vehicle	9,618	18,353	18,574	-222	11,950	12,071	-121
	Bus	449	836	805	32	559	536	23
	Truck	2,881	5,531	5,624	-93	3,517	3,541	-23
	Motorcycle	41,595	86,428	81,010	5,418	139,866	130,296	9,570
	<b>Total</b>	<b>153,938</b>	<b>304,197</b>	<b>300,433</b>	<b>3,764</b>	<b>298,046</b>	<b>289,347</b>	<b>8,699</b>
Vehicle Hour	Car	3,293	5,842	7,326	-1,483	3,627	4,603	-977
	Jeepney	340	610	767	-158	985	1,190	-205
	Utility Vehicle	356	605	778	-173	382	511	-129
	Bus	16	27	34	-6	18	21	-3
	Truck	106	164	230	-67	101	143	-42
	Motorcycle	1,518	2,541	3,270	-730	4,050	5,900	-1,850
	<b>Total</b>	<b>5,629</b>	<b>9,788</b>	<b>12,405</b>	<b>-2,617</b>	<b>9,162</b>	<b>12,369</b>	<b>-3,206</b>
Traffic Volume	Car	67,712	132,486	132,376	111	84,621	84,692	-71
	Jeepney	7,379	14,518	14,529	-11	23,964	24,062	-98
	Utility Vehicle	6,917	13,393	13,417	-24	8,687	8,717	-30
	Bus	352	632	628	4	421	421	0
	Truck	2,001	3,890	3,903	-14	2,460	2,443	16
	Motorcycle	28,668	55,779	55,808	-28	90,305	89,762	542
	<b>Total</b>	<b>113,029</b>	<b>220,698</b>	<b>220,660</b>	<b>38</b>	<b>210,458</b>	<b>210,098</b>	<b>360</b>
Average Travel Speed (Km/Hour)	Car	27.3	29.9	24.0	5.9	30.8	24.4	6.4
	Jeepney	27.5	30.3	24.0	6.2	31.0	25.6	5.3
	Utility Vehicle	27.0	30.4	23.9	6.5	31.3	23.6	7.7
	Bus	27.5	30.8	24.0	6.9	31.9	25.7	6.2
	Truck	27.2	33.8	24.4	9.4	34.8	24.7	10.1
	Motorcycle	27.4	34.0	24.8	9.2	34.5	22.1	12.4
	<b>Average</b>	<b>27.3</b>	<b>31.1</b>	<b>24.2</b>	<b>6.9</b>	<b>32.5</b>	<b>23.4</b>	<b>9.1</b>

Source: JICA Study Team

**Table 3.3-4 Daily Vehicle-km, Vehicle-Hour and Average Travel Speed  
(EDSA /Roosevelt/ Congressional Intersection)**

Indicator	Vehicle Category	2011 (Daily)	2018 (Daily)			2028 (Daily)		
			2018 (With)	2018 (Without)	With - Without	2028 (With)	2028 (Without)	With - Without
Vehicle Km	Car	118,775	144,485	150,012	-5,527	134,665	139,990	-5,325
	Jeepney	20,782	22,329	26,650	-4,321	29,268	35,042	-5,774
	Utility Vehicle	18,410	22,402	23,286	-884	20,734	21,591	-857
	Bus	15,196	18,316	19,392	-1,076	16,966	17,962	-996
	Truck	14,081	17,072	17,669	-597	15,885	16,530	-646
	Motorcycle	21,078	25,264	26,579	-1,315	32,937	34,900	-1,963
	<b>Total</b>	<b>208,323</b>	<b>249,869</b>	<b>263,588</b>	<b>-13,720</b>	<b>250,454</b>	<b>266,016</b>	<b>-15,561</b>
Vehicle Hour	Car	3,915	4,770	5,116	-347	4,444	4,810	-366
	Jeepney	710	703	945	-242	926	1,252	-326
	Utility Vehicle	610	749	799	-50	691	743	-51
	Bus	510	543	675	-132	503	629	-127
	Truck	469	569	612	-43	527	577	-50
	Motorcycle	701	904	916	-12	1,183	1,210	-27
	<b>Total</b>	<b>6,914</b>	<b>8,237</b>	<b>9,063</b>	<b>-826</b>	<b>8,274</b>	<b>9,221</b>	<b>-947</b>
Traffic Volume	Car	78,477	99,454	99,193	261	92,615	92,521	94
	Jeepney	9,664	12,419	12,338	82	16,302	16,266	37
	Utility Vehicle	11,131	14,190	14,178	12	13,159	13,182	-24
	Bus	10,550	13,480	13,427	53	12,468	12,475	-7
	Truck	8,484	10,934	10,997	-63	10,148	10,266	-118
	Motorcycle	13,641	17,250	17,239	10	22,662	22,662	0
	<b>Total</b>	<b>131,948</b>	<b>167,726</b>	<b>167,372</b>	<b>355</b>	<b>167,353</b>	<b>167,372</b>	<b>-18</b>
Average Travel Speed (Km/Hour)	Car	30.3	30.3	29.3	1.0	30.3	29.1	1.2
	Jeepney	29.3	31.8	28.2	3.6	31.6	28.0	3.6
	Utility Vehicle	30.2	29.9	29.2	0.8	30.0	29.1	0.9
	Bus	29.8	33.7	28.7	5.0	33.8	28.5	5.2
	Truck	30.0	30.0	28.9	1.2	30.2	28.7	1.5
	Motorcycle	30.1	27.9	29.0	-1.1	27.8	28.8	-1.0
	<b>Average</b>	<b>30.1</b>	<b>30.3</b>	<b>29.1</b>	<b>1.3</b>	<b>30.3</b>	<b>28.8</b>	<b>1.4</b>

Source: JICA Study Team

**Table 3.3-5 Daily Vehicle-km, Vehicle-Hour and Average Travel Speed  
(EDSA /North/West/Mindanao Intersection)**

Indicator	Vehicle Category	2011 Daily	2018 (Daily)			2028 (Daily)		
			2018 (With)	2018 (Without)	With - Without	2028 (With)	2028 (Without)	With - Without
Vehicle Km	Car	257,061	308,345	317,028	-8,683	289,377	297,381	-8,004
	Jeepney	22,322	23,009	26,265	-3,256	27,499	31,912	-4,413
	Utility Vehicle	26,357	30,795	32,449	-1,654	28,887	30,528	-1,641
	Bus	14,382	18,139	18,292	-154	16,835	16,960	-125
	Truck	23,232	28,545	29,065	-520	26,755	27,198	-443
	Motorcycle	40,702	50,013	50,930	-917	65,028	66,657	-1,629
	<b>Total</b>	<b>384,056</b>	<b>458,845</b>	<b>474,029</b>	<b>-15,184</b>	<b>454,382</b>	<b>470,635</b>	<b>-16,254</b>
Vehicle Hour	Car	9,191	10,754	13,360	-2,606	9,753	12,072	-2,319
	Jeepney	834	939	1,079	-141	1,114	1,293	-179
	Utility Vehicle	972	1,135	1,377	-242	1,030	1,284	-254
	Bus	460	506	636	-130	466	567	-102
	Truck	895	1,015	1,349	-334	919	1,223	-303
	Motorcycle	1,544	1,723	2,603	-880	2,198	3,293	-1,095
	<b>Total</b>	<b>13,895</b>	<b>16,072</b>	<b>20,405</b>	<b>-4,332</b>	<b>15,481</b>	<b>19,732</b>	<b>-4,252</b>
Traffic Volume	Car	167,998	206,255	205,934	321	193,438	193,023	415
	Jeepney	10,459	11,455	11,489	-34	12,837	12,828	8
	Utility Vehicle	16,403	19,929	19,937	-9	18,690	18,755	-65
	Bus	10,381	13,198	13,194	4	12,242	12,246	-4
	Truck	16,154	20,309	20,233	77	18,959	18,945	14
	Motorcycle	26,130	32,745	32,588	156	42,425	42,358	67
	<b>Total</b>	<b>247,526</b>	<b>303,890</b>	<b>303,375.1</b>	<b>515.0</b>	<b>298,592</b>	<b>298,156</b>	<b>436</b>
Average Travel Speed (Km/Hour)	Car	28.0	28.7	23.7	4.9	29.7	24.6	5.0
	Jeepney	26.8	24.5	24.3	0.2	24.7	24.7	0.0
	Utility Vehicle	27.1	27.1	23.6	3.6	28.1	23.8	4.3
	Bus	31.3	35.8	28.7	7.1	36.2	29.9	6.3
	Truck	26.0	28.1	21.5	6.6	29.1	22.2	6.9
	Motorcycle	26.4	29.0	19.6	9.5	29.6	20.2	9.3
	<b>Total</b>	<b>27.6</b>	<b>28.5</b>	<b>23.2</b>	<b>5.3</b>	<b>29.4</b>	<b>23.9</b>	<b>5.5</b>

Source: JICA Study Team

**Table 3.3-6 Daily Vehicle-m, Vehicle-Hour and Average Travel Speed  
(C-5 Green Meadows/Acropolis/Calle Industria)**

Indicator	Vehicle Category	2011 (Daily)	2018 (Daily)			2028 (Daily)		
			2018 (With)	2018 (Without)	With - Without	2028 (With)	2028 (Without)	With - Without
Vehicle Km	Car	324,251	367,398	373,519	-6,121	543,481	552,795	-9,314
	Jeepney	13,173	15,185	15,213	-28	22,715	22,867	-152
	Utility Vehicle	54,476	62,176	62,507	-331	92,139	92,672	-533
	Bus	772	858	865	-8	1,302	1,299	2
	Truck	34,601	39,742	39,905	-163	58,850	59,115	-265
	Motorcycle	90,496	103,721	104,143	-423	152,917	153,418	-501
	<b>Total</b>	<b>517,769</b>	<b>589,078</b>	<b>596,153</b>	<b>-7,074</b>	<b>871,404</b>	<b>882,166</b>	<b>-10,763</b>
Vehicle Hour	Car	10,309	10,885	11,936	-1,051	17,874	19,823	-1,949
	Jeepney	419	419	487	-67	702	854	-153
	Utility Vehicle	1,736	1,783	2,003	-220	2,971	3,531	-560
	Bus	25	23	28	-4	39	48	-8
	Truck	1,102	1,108	1,278	-170	1,822	2,182	-360
	Motorcycle	2,878	3,008	3,329	-321	4,928	5,534	-606
	<b>Total</b>	<b>16,468</b>	<b>17,227</b>	<b>19,061</b>	<b>-1,834</b>	<b>28,336</b>	<b>31,972</b>	<b>-3,635</b>
Traffic Volume	Car	114,767	132,136	132,178	-42	195,412	195,166	246
	Jeepney	4,360	5,054	5,051	3	7,574	7,591	-17
	Utility Vehicle	18,281	20,971	20,974	-3	30,992	30,992	0
	Bus	257	288	288	0	428	428	0
	Truck	11,526	13,255	13,286	-31	19,582	19,606	-24
	Motorcycle	30,917	35,590	35,667	-77	52,532	52,401	132
	<b>Total</b>	<b>180,108</b>	<b>207,294</b>	<b>207,444</b>	<b>-151</b>	<b>306,520</b>	<b>306,183</b>	<b>337</b>
Average Travel Speed (Km/Hour)	Car	31.5	33.8	31.3	2.5	30.4	27.9	2.5
	Jeepney	31.4	36.2	31.3	4.9	32.4	26.8	5.6
	Utility Vehicle	31.4	34.9	31.2	3.7	31.0	26.2	4.8
	Bus	31.5	36.7	31.2	5.5	33.2	27.3	5.9
	Truck	31.4	35.9	31.2	4.7	32.3	27.1	5.2
	Motorcycle	31.4	34.5	31.3	3.2	31.0	27.7	3.3
	<b>Total</b>	<b>31.4</b>	<b>34.2</b>	<b>31.3</b>	<b>2.9</b>	<b>30.8</b>	<b>27.6</b>	<b>3.2</b>

Source: JICA Study Team

## CHAPTER 4

### STUDY OF EACH INTERCHANGE

#### 4.1 DESIGN STANDARD FOR HIGHWAY AND FLYOVER

Design standards for Highway and Flyover adapted prevailing DPWH design standards, except for seismic acceleration coefficient which was increased from 0.4g to 0.5g due to scheduled change in the ASEP design code.

#### 4.2 C-3/E. RODRIGUEZ AVENUE

##### 4.2.1 Review of Previous Detailed Design

The detailed design of the interchange was prepared by Nippon Engineering Consultant Co., Ltd. in association with DCCD Engineering Corporation and Pertconsult International in February 2005 (original contract) and July 2006 (Supplemental Contract).

##### (1) Topographic Condition

There were no significant changes noted in the topographic conditions of the area between the time of the detailed design to the present.

##### (2) Geotechnical Conditions

The bearing stratum in the proposed area is tuffaceous rock sequence that underlie, deeper than 2–7m from ground surface.

##### (3) Hydrological Conditions

Based on interviews with local residents, the flooding area for the 2 years return period is generally consistent with the flooding area.

##### (4) Design Standards

DPWH design standards for highway and flyover were adapted.

##### (5) Road Alignment and Structural Conditions

###### Along C-3

The total length of the project section along this road segment is 2,105m, consisting of 275m of 4-lanes flyover, 205m of approach roads and 1,625m of embankment roads. The highest embankment height to Quezon City direction is 2.50m and 1.85m height to Sta. Mesa direction. Type of Flyover is RC voided slab and PC box girder.

###### Along E. Rodriguez Avenue

The road is 827m long and four lanes with a total width of 20.0m and highest embankment

height along E. Rodriguez Avenue is 1.55m.

**(6) Environmental and Social Conditions**

The Environmental Compliance Certificate (ECC) had been issued by the DENR-EMB in January 2005. It stated that 94 informal settlers in 2 Barangays will be affected.

**(7) Identified Problems and Recommendations**

**Identified Problems**

There has been no study yet on the possible impacts of flooding to the people living within the vicinity of the project area and also no documents showing public acceptance on the proposed raising of the current road elevation.

**Recommendations**

- (a) Detailed hydrological study should be conducted
- (b) The most appropriate countermeasure(s) against flood, like raising the present road elevation, should be thoroughly studied.

**4.2.2 Preliminary Design of Interchange**

**(1) Study and Countermeasure against Flood**

The following two studies took into consideration river channel improvement:

- B T M C (August 1979)
  - Highest water elevation = 4.40m (30 years return period)
  - Dredging depth = 1.50m
  - Widening = 0 m
- CTI and others (March 2002)
  - Highest water elevation = 4.90m (50 years return period)
  - Dredging depth = 0.94m
  - Widening to = 53.5m (about 9m widening of existing river width)

When the road surface elevations are raised, the following issues will become a major concern:

- The access of the public/residents to the road from the roadside land will be difficult.
- The inundation inside a levee will be increased at the upstream side of the road because the elevated roads obstruct the surface flow as sort of a dam.

In conclusion, the elevated highway should be provided proper counter measure for the problem of flooding and the fundamental problem of flood should be properly addressed by a flood control management project.



## (2) Comparative Study

The following three (3) alternatives are proposed as the most suitable schemes for comparison based on the site and traffic conditions:

Scheme-1 : 275.0m long flyover with 2 lanes per direction (PC Box and PC Voided Slab Bridge) and 630m long 6 lanes additional approach road (Original Design).

Scheme-2 : 280.0m long (PC Box and RC Voided Slab Bridge) with 2 lanes per direction.

Scheme-3 : 280.0m long (PC Box and RC Voided Slab Bridge) with 2 lanes per direction and 690m long 4 lanes additional approach with RCBC

Among three (3) schemes, scheme-3 was selected though it was more expensive than scheme-2 by approximately 22% due specifically to the 690m extent of elevated road that will prevent flooding during heavy rains and typhoon and this scheme can provide 2-lanes per direction of service road at-grade section which will be deemed sufficient for any activity of the people along the-road section.

Detailed scheme comparison is shown in **Table 4.2-1**.

**Table 4.2-1 Scheme Comparative Table of C-3/E. Rodriguez**

Scheme	SCHEME-1 ORIGINAL DESIGN (6-Lane Additional Approach)		SCHEME - 2 No Additional Approach		Scheme-3 4-LANES ADDITIONAL APPROACH	
Structure Schemes	4-Lane Flyover: L= 275.0m PC VOIDED SLAB : 7@25.0m PC Box Girder 2@30.0m + 40.0m Approach Road : L=630m(6-lane)		4-Lane Flyover: L= 280.0m RC VOIDED SLAB : 10@18.0m=180.0m PC Box Girder : 2@30.0m+40.0m=100.0 Approach Road : L=207.7m		4-Lane Flyover : L= 280.0m RC VOIDED SLAB : 10@18.0m=180.0m PC Box Girder : 2@30.0m+40.0m=100.0 Approach Road : L=598.0m	
Construction Cost	Closed due to confidentiality					
Construction Performance and Duration	18 Months ● Construction method and procedure is standard ● Total 6-lanes embankment road construction affects to existing traffic during construction	△	14 Months ● Construction method and procedure is standard ● Less impact to traffic during construction due to no additional embankment approach	⊙	17 Months ● Construction method and procedure is standard ● Small impact to traffic during construction due to 4-lanes additional approach	⊙
Environmental and Social Condition	● Requires R.O.W acquisition near I/C due to improvement of I/C (Demolish 3 building at I/C) ● The people on each side of C-3 disconnected from each other due to 630m extent of elevated thru road	△	● No R.O.W acquisition due to improvement I/C is within R.O.W. ● The people on each side of C-3 is still connected from each other as almost same condition as present	⊙	● No R.O.W acquisition due to improvement of I/C is within R.O.W. ● The people on each side of C-3 disconnected from each other can be prevented due to provide RCBC	⊙
Traffic Condition	● No overflow of road during flood ● No direct access to elevated road section from side road due to no side road.	△	● No improvement against flood (road overflows during flood) ( Average unpassable day per year is 2 or 3 days)	△	● No overflow of road during flood ● Can provide 2-lanes each side road on both directions ● No direct side road traffic access due to 600m extent of elevated thru road section	⊙
Over all Evaluation	● More Expensive than other 2-schemes ● Requires R.O.W acquisition ● No direct access to elevated road section from side road and disconnects the community ● Big impact on traffic during construction due to 6-lanes additional approach ● No flood on thru road permanently	△	● Cheapest among the schemes ● Can provide direct access to road ● No R.O.W acquisition ● No traffic improvement during flood (road overflows during flood) (average unpassable day per year is 2 or 3 days)	⊙	● More expensive than scheme-2 ● 600m extent of elevated thru road prevents direct side road access ● No R.O.W acquisition ● Can provide 2-lanes each side road on both directions ● No flood on thru road permanently	⊙

LEGEND : ○ advantage  
● disadvantage

Source: JICA Study Team

### (3) Preliminary design of Selected Scheme

Preliminary design was conducted based on the conditions previously discussed in the comparative study.

### (4) Construction Plan and Traffic Management during Construction

Construction plan, PERT/CPM and traffic management has been studied. PERT/CPM shows that construction duration of this flyover is 17 months.

### (5) Bill of Quantity and Cost Estimate

The Civil Works cost was estimated based on the following and other factors:

- Unit price of similar GOP and BOT projects implemented or tendered from 2010-2011 was used and but unit price of major item was estimated based on 2011 price.
- Procedures and composition for the derivation of base construction cost referred to and based on similar projects.

Estimated cost of this flyover is as follows:

Civil work cost	PhP	XXX
Foreign currency	PhP	XXX
Local currency	PhP	XXX
Tax	PhP	XXX

Implementation of the C-3/E. Rodriguez Interchange was cancelled by the DPWH to give priority to the construction of Skyway Stage 3, second level, along C-3 under BOT scheme.

## **4.3 EDSA-ROOSEVELT AVENUE/CONGRESSIONAL AVENUE**

### **4.3.1 Review of Previous Detailed Design**

The detailed design of the project was done by Katahira & Engineers International in association with Proconsult, Inc. and United Technologies, Inc. in February 2001.

#### **(1) Topographic Conditions**

There are no significant changes in the topographic conditions of the area from the time of the detailed design to the present, except for the construction of MRT-3, Muñoz Station, the bus stop lanes on both directions and pedestrian bridges at the intersection.

#### **(2) Geotechnical Conditions**

The bearing stratum in the proposed area is tuffaceous rock sequence that underlies 16m deeper than ground surface.

#### **(3) Hydrological Conditions**

The San Francisco River crosses the EDSA at 50m Balintawak side from the proposed intersection. There are no specific issues on the hydrological conditions in the proposed area since there is no record of flooding.

#### **(4) Design Standards**

DPWH design standards for highway and flyover were applied.

#### **(5) Road Alignment and Structural Conditions**

##### **Northbound**

- (a) Horizontal alignment is passing through the right side of MRT-3 with 1,075m radius curve. Vertical grade at each side of the approach sections is 5.0%.
- (b) Total length of the project section is 729m and total length of flyover is 502m with RC and PC voided slab for superstructures.

##### **Southbound**

- (a) Horizontal alignment is passing thru the left side of MRT-3 with 1,055m radius curve. Vertical grade of each side of the approach sections is 5.0%.
- (b) Total length of the project section is 729m; total length of flyover is 500m with RC and PC voided slab for superstructures.

#### **(6) Environmental and Social Conditions**

The ECC for EDSA/North Avenue-West Avenue and EDSA/Roosevelt Interchanges Project had been issued by DENR-EMB in January 2002. Approximately, the total area that will be affected is around 1,769 sq. m.

## **(7) Identified Problems and Recommendation**

### **Identified Problems**

No problems were identified in the completed plans and detailed design of this interchange, but total re-planning and redesign will be required due to the constructed MRT-3 and Muñoz Station and the Pedestrian Bridges at the intersection.

### **Recommendations**

A careful study of the vertical and horizontal clearances against the constructed Muñoz Station and MRT-3 viaduct structures should be undertaken.

## **4.3.2 Preliminary Design of Interchange**

### **(1) Comparative Study**

The following three (3) alternatives are proposed as the most suitable schemes for comparison based on the site traffic conditions.

Scheme-1 : Flyover with 422m long and 3 lanes per direction while maintaining all pedestrian bridges. Superstructure is PC voided slab

Scheme-2 : Flyover with 366m long and 3 lanes per direction without pedestrian bridges near Muñoz Station. Superstructure is PC voided slab

Scheme-3 : Flyover with 719m(NB) and 880m(SB) long and 3 lanes per direction while maintaining all pedestrian bridges and improving at grade intersection. Superstructure is steel box girder and PC voided slab

Among the three (3) alternatives, scheme-2 was selected due to cheapest construction cost, shorter construction duration and superior vertical grade against the other schemes.

The detailed scheme comparison is shown in **Table 4.3-1**

**Table 4.3-1 Scheme Comparison Table of EDSA/Roosevelt /Congressional Interchange**

Schemes	SCHEME-1 FLYOVER (Maintain all Pedestrian Bridges)	SHEME - 2 FLYOVER (No Pedestrian Bridge near Muñoz Station)	SHEME - 3 FLYOVER (Maintain all Pedestrian Bridges and Improve At-grade Intersection)
Structure	3-Lane Flyover : 14@28.0m+30.0m=422.0m (PC Voided Slab) Approach Road : 223.7m 4-Pedestrian Bridges : 150m Same structures between South and North bound	3-Lane Flyover : 12@28.0m+30m=366.0m (PC Voided Slab) Approach Road : 207.5m 3-Pedestrian Bridges : 95m Same structures between South and North bound	3-Lane Flyover : 18@28.0m+2@40m+3@45m=719.0m (N.B) 24@27.9m+5@42.2m=880.5 (S.B) Approach Road : 291.5m(NB) +261.0m(SB)=552.5m 4-Pedestrian Bridges : 150m
Construction Cost	Closed due to confidentiality		
Construction Performance and Duration	23 Months ○ Construction method and procedure is standard ● Requires demolition and reconstruction of 4 existing pedestrian bridges	22 Months ○ Construction method and procedure is standard ○ Requires demolition of 4 existing pedestrian bridges but reconstruction only 3 Pedestrian Bridges. (Can't construct one bridge at near side of Muñoz Station, due to lower vertical grade)	30 Months ○ Construction method and procedure is standard ● Requires demolition and reconstruction of 4 existing pedestrian bridges ● Too closer construction activities to existing Muñoz Station
Environmental and Social Condition	○ No additional R.O.W ● Lower volume of exhaust fumes than Scheme-3	○ No additional R.O.W ○ Low volume of exhaust fumes and noise due to lowest vertical grade	○ No additional R.O.W ● Very high volume of exhaust fumes and noise due to longer vertical grade
Traffic Condition at Grade I/C	○ No regular traffic flow alignment at the at-grade I/C due to pier of Line 1 was located within I/C but still manageable by 4 phase-signalization	○ No regular traffic flow alignment at the at-grade I/C due to pier of Line 1 was located within I/C but still manageable by 4 phase-signalization ● Long route for pedestrian over EDSA given us no construction of pedestrian bridge at near side of Muñoz Station but pedestrian can utilize Muñoz Station	○ Better traffic flow alignment at grade movement compare to other 2 schemes
Overall Evaluation	● Expensive than Scheme -2 ○ Reconstruction of 4 Pedestrian Bridges ● Higher volume of exhaust fumes and noisier than Scheme - 2 due to higher vertical grade	○ Cheapest among the schemes ○ Shorter construction duration ○ Reconstruct 3-pedestrian bridges but no construction of pedestrian bridge at near side of Muñoz Station ○ Lower vertical grade among the schemes	● Most expensive among the schemes ○ Reconstruct of 4 pedestrian bridges ● Heavily affects traffic during construction of high pier and construction activities are too closer to existing Muñoz Sta. ● Longer Construction duration

LEGEND : ○ advantage  
● disadvantage

Source: JICA Study Team

**(2) Preliminary Design of Selected Scheme**

Preliminary design was conducted based on the conditions which were previously discussed in the comparative study.

**(3) Construction Plan and Traffic Management during Construction**

Construction plan, PERT/CPM and traffic management have been studied. PERT/CPM shows that construction duration of this flyover is 22 months.

**(4) Bill of Quantity and Cost Estimate**

Civil Works Cost for EDSA/Roosevelt/Congressional IC has been estimated based on similar conditions of C-3/E. Rodriguez IC.

Estimated cost of this flyover is as follows:

Civil work cost	PhP	XXX
Foreign currency	PhP	XXX
Local currency	PhP	XXX
Tax	PhP	XXX

#### 4.4 EDSA/NORTH AVENUE/WEST AVENUE/MINDANAO AVENUE

##### 4.4.1 Review of Previous Detailed Design

The detailed design of this proposed interchange was prepared by Katahira & Engineers International in association with Proconsult, Inc. and United Technologies, Inc. in February 2001.

##### (1) Topographic Conditions

There are no significant changes in topographic conditions from the time of the detailed design to present, except for the construction of pedestrian bridges and bus stop lanes at the intersection.

##### (2) Geotechnical Conditions

The bearing stratum is tuffaceous rock sequence that underlie, 1-4m deeper than from ground surface. Foundation type of all of substructures were spread type foundation.

##### (3) Hydrological Conditions

There are no rivers and creeks nearby and elevations are higher than the surroundings. Therefore, there are no specific issues on the hydrological conditions in the proposed area.

##### (4) Design Standards

DPWH design standards for highway and flyover were applied.

##### (5) Road Alignment and Structural Conditions

The road alignments and structural conditions have the following characteristics:

##### **EDSA Southbound**

The total length of the project section and the flyover are 854m and 361m, respectively. The length of the left turn flyover (EDSA–North Avenue) which is located above the EDSA northbound flyover is 286m with RC and PC voided slab type of superstructure.

##### **EDSA Northbound**

The total length of the project section and the flyover are 569m and 343m, respectively, and the type of superstructures are RC and PC voided slab.

##### **EDSA–North Avenue Left Turn Flyover**

⇒ North Avenue Straight

Total length of project section = 1,228m; Length of flyover = 1,011m

⇒ North Avenue–Mindanao Avenue

Total length of project section = 306m; Length of flyover = 180m

##### **West Avenue–North Avenue Flyover**

The flyover has two lanes and horizontal alignment of 80m radius right curve at the intersection

which merges with EDSA–North Avenue Left Turn Flyover after the curve. The lengths of the project section and flyover are 483m and 392m, respectively, and type of superstructures are RC and PC voided slab.

**(6) Environmental and Social Conditions**

The ECC for EDSA/North Avenue-West Avenue and EDSA/Roosevelt Interchanges Project had been issued by DENR-EMB in January 2002. Based on the ROW Map 2001, the affected area is approximately 5,768 sq. m.

**(7) Identified Problems and Recommendations**

**Identified Problems**

- (a) No problems were identified in the completed plans and detailed design of this interchange but total re-planning and redesign are required due to the planned construction of a new station, the Common Station along LRT-1 in front of SM North, and of MRT-7 which will

**Pass along North Avenue.**

- (b) The construction of a Left Turn Flyover from EDSA to North Avenue will not be possible with the planned construction of the Common Station.

**Recommendations**

Proper coordination and discussions with the DOTC, LRTA and other concerned agencies should be made and the necessary data and information on the MRT-3 and LRT Line-1 extension and detailed design of the Common Station and MRT 7 should be obtained for Preliminary Design.

**4.4.2 Preliminary Design (EDSA/North/West Interchange)**

**(1) Comparative study**

The following two (2) alternatives are proposed as the most suitable for comparison based on site and traffic conditions.

Scheme-1 : Flyover with, 342m long north bound and 319m long south bound.

Scheme-2 : Cut and cover tunnel with, 231m long north bound and 131m long south bound.

Between the two (2) schemes of flyover and cut and cover tunnel, the flyover scheme was selected considering that construction cost is much cheaper, no ROW acquisition required, construction duration is shorter and specific O & M will not be needed.

Detailed scheme comparison is shown in **Table 4.4-1**.

**Table 4.4-1 Scheme Comparison Table of EDSA/North/West Interchange**

Description	Scheme-1 Flyover	Scheme-Cut and Cover Tunnel	
<b>Structure</b>	3-lane flyover North Bound : 9@28.0m+3@ 30.0m (pc voided slab)=342.0m South Bound: 7@28.0m+3@ 26.0m+2@22.5m(pc voided slab)=319.0m Approved Section : North Bound: 226.6m South Bound: 244.6m	3-lane North Bound Tunnel: 231.4m Approach: 523.6m 3-lane South Bound Tunnel: 131.3m Approach: 535.9m	
<b>Construction Cost</b>	Closed due to confidentiality		
<b>Construction Performance and Duration</b>	<ul style="list-style-type: none"> <li>○ 22 months</li> <li>○ Construction method and procedure is standard</li> <li>○ Provide at least 2-lanes traffic per direction during construction</li> </ul>	<ul style="list-style-type: none"> <li>⊙ 30 Months</li> <li>● Requires to find dumping place for 84,800m<sup>3</sup> of excavated soil</li> <li>● Requires special construction method and procedure for construction of sump pit and cross pipe about 10m deep under ground</li> <li>● Provide 1.5 lane per direction only during construction</li> </ul>	△
<b>Environmental and Social Condition</b>	<ul style="list-style-type: none"> <li>○ No R.O.W acquisition</li> <li>○ Traffic noise is severe than scheme-2 but not concentrated</li> </ul>	<ul style="list-style-type: none"> <li>⊙ Aesthetic view of area will be preserved</li> <li>● Requires about 400m<sup>2</sup> R.O.W acquisition for sump pit</li> <li>● Greater Impact on traffic due to longer construction duration</li> <li>● Noise and exhaust fumes are concentrated at both entrance</li> </ul>	△
<b>Traffic Condition at Grade I/C</b>	<ul style="list-style-type: none"> <li>○ Easier traffic management during construction</li> </ul>	<ul style="list-style-type: none"> <li>● Difficult traffic management during construction</li> </ul>	○
<b>O &amp; M</b>	<ul style="list-style-type: none"> <li>○ No specific O &amp; M required</li> </ul>	<ul style="list-style-type: none"> <li>● Requires periodic monitoring and maintenance of sump pit drain water pump up system and illumination</li> </ul>	○
<b>Over all Evaluation</b>	<ul style="list-style-type: none"> <li>○ Much cheaper than scheme-2</li> <li>○ Shorter construction duration and easier to manage existing traffic during construction</li> <li>○ No specific O &amp; M required</li> <li>○ No R.O.W. acquisition</li> </ul>	<ul style="list-style-type: none"> <li>● More than 3-times expensive than scheme-1</li> <li>● Longer construction duration and hard to manage existing traffic during construction</li> <li>● Sump pit requires 400m<sup>2</sup> of R.O.W and difficult construction method and sequence</li> </ul>	△

LEGEND : ○ advantage  
● disadvantage

Source: JICA Study Team

**(2) Preliminary Design of Selected Scheme (EDSA/North/West Interchange)**

Preliminary design was conducted based on the conditions discussed previously in the comparative study.

**(3) Construction Plan and Traffic Management during Construction**

Construction plan, PERT/CPM and traffic management has been studied. PERT/CPM shows that construction duration of this flyover is 22 months.

**4.4.3 Preliminary Design (North/Mindanao Interchange)**

**(1) Comparative study**

The following two (2) alternatives are proposed as the most suitable for comparison based on site and traffic conditions:

Scheme-1 : Left turn flyover from North Ave to Mindanao Ave (3<sup>rd</sup> level) and left turn flyover from Mindanao Ave to North Ave (2<sup>nd</sup> level)

Scheme-2 : Left turn cut and cover tunnel from North Ave to Mindanao Ave (under pass) and left turn flyover from Mindanao Ave to North Ave (2<sup>nd</sup> level)

Between two (2) schemes, scheme-2 was selected due to the following reasons:

- Construction cost is cheaper



- Environmental conditions are better (aesthetic, noise and exhaust fumes)
- Traffic conditions are better (ensuring access to The Block SM North EDSA)

Detailed scheme comparison is shown in **Table 4.4-2**.

**Table 4.4-2 Scheme Comparison of North/Mindanao Interchange**

Description	Scheme-1 Left Turn Flyover North-Mindanao (3rd Level) Left Turn Flyover Mindanao-North (2nd Level)	Scheme-2 Left Turn North-Mindanao (Underpass) Left Turn Flyover Mindanao-North (2nd Level)
Structure	Flyover (N-M) : 495.0m 15@18.0m+5@45.0m (RC voided and steel box) Approach: 214.5m Flyover (M-N): 318m, 11@18.0m+4@30.0m (RC and PC voided slab) Approach: 205.4m	Tunnel : 95m+open section 363.5m Flyover (M-N) : 318m, 11@18.0m+4@30.0m (RC and PC voided slab) Approach : 205.4m
Construction Cost	Closed due to confidentiality	
Construction Performance and Duration	<b>26 months</b> <ul style="list-style-type: none"> <li>● Construction method is standard but complicated due to double flyovers</li> <li>● Requires steel box girder due to over the 3rd level flyover</li> </ul>	<b>24 months</b> <ul style="list-style-type: none"> <li>● Construction method is standard but complicated due to 2-layer of structure</li> <li>● Requires special construction method and procedure for const. of sump pit</li> </ul>
Environmental and Social Condition	<ul style="list-style-type: none"> <li>● Aesthetic view is worthier than scheme-2</li> <li>● Requires R.O.W at the entrance of 3rd level flyover along North Ave.</li> <li>● Noise and exhaust fumes are greater than scheme-2 due to long and steep slope</li> </ul>	<ul style="list-style-type: none"> <li>○ Aesthetic view is better than scheme-1</li> <li>○ Requires R.O.W acquisition for sump pit location</li> <li>○ Noise an exhaust fumes are smaller than scheme-1</li> </ul>
Traffic Condition at Grade I/C	<ul style="list-style-type: none"> <li>● Close access to The Block SM Edsa</li> <li>● Restrict section is longer than scheme-2</li> </ul>	<ul style="list-style-type: none"> <li>○ No close access to The Block SM North Edsa</li> <li>○ Restrict section is shorter than Scheme-1</li> </ul>
O & M	<ul style="list-style-type: none"> <li>● Requires painting for steel members which is harder due to above road and flyover</li> </ul>	<ul style="list-style-type: none"> <li>○ Requires periodic monitoring and maintenance of water pump up system</li> </ul>
Overall Evaluation	<ul style="list-style-type: none"> <li>● Construction cost expensive than scheme-2</li> <li>● Construction of 3rd level steel box girder is complicated</li> <li>● Environmental condition is worthier than scheme-2</li> <li>● Traffic condition is worthier than scheme-2</li> </ul>	<ul style="list-style-type: none"> <li>○ Construction cost is cheaper than scheme-1</li> <li>● Requires special construction method and procedure for const. of sump pit</li> <li>○ Environmental issue is much better than scheme-1</li> <li>○ Traffic condition is better than scheme-1</li> </ul>

LEGEND :  
 ○ advantage  
 ● disadvantage

Source: JICA Study Team

## (2) Preliminary Design of Selected Scheme

Preliminary design was conducted based on the conditions previously discussed in the comparative study.

## (3) Construction Plan and Traffic Management during Construction

Construction plan, PERT/CPM and traffic management have been studied. PERT/CPM shows that construction duration of this flyover is 24 months.

## (4) Bill of Quantity and Cost Estimate

Civil Works Cost for EDSA/North/West/Mindanao IC has been estimated based on the similar conditions of C-3/E. Rodriguez IC.

Estimated cost of this flyover is as follows:

Civil work cost	PhP	XXX
Foreign currency	PhP	XXX
Local currency	PhP	XXX
Tax	PhP	XXX

## **4.5 C-5/KALAYAAN AVENUE**

### **4.5.1 Review of Previous Detailed Design**

The detailed design of the interchange was prepared by Nippon Engineering Consultant Co., Ltd. in association with DCCD Engineering Corporation and Pertconsult International in March 2003.

#### **(1) Topographic Conditions**

There are no significant changes in the topographic conditions of the area between the time of the detailed design to the present, except for the U-Turn Flyovers constructed on both sides of the interchange along C-5 and the on-going construction of another flyover from Bonifacio Global City to C-5 toward Pasig City.

#### **(2) Geotechnical Conditions**

The bearing stratum in this proposed area is tuffaceous rock sequence that underlies 1-3m deeper than from ground surface. Therefore, type of foundation for all substructures is spread type foundation.

#### **(3) Hydrological Conditions**

There is a creek located 250m eastside from the C-5–Kalayaan intersection. However, it is noted that this area is not prone to flooding because elevations of the proposed area are 5m higher than the ground elevations near the creek.

#### **(4) Design Standards**

DPWH design standards for highway and flyover were applied.

#### **(5) Road Alignment and Structural Conditions**

A depressed structure was proposed and designed along C-5.

- (a) 490m of depressed structure will have a horizontal straight alignment along C-5
- (b) The standard section along C-5 has three lanes for each direction at the depressed section and two lanes for each direction at the ground section.

#### **(6) Environmental and Social Conditions**

The ECC for C-5/Lanuza St.-Julia Vargas St. and C-5/Kalayaan Ave. Interchanges Project had been issued by DENR-EMB in December 2001.

#### **(7) Identified Problems and Recommendations**

##### **Identified Problems**

- (a) No problems were identified in the detailed design. However, the U-Turn Flyovers constructed at both sides of the intersection along C-5 are considered to be substandard structures under the design code.

- (b) Traffic conditions should be studied after completion of the on-going construction of the flyover from Bonifacio Global City toward Pasig City, which will merge in front of the southern side U-Turn Flyover.

### **Recommendations**

After completion of the flyover construction, a more comprehensive study of actual traffic at the intersection might be necessary to ensure that its smooth flow is maintained.

#### **4.5.2 Advice on Technical Issue and Design Option**

##### **(1) C-5 improvement plan of DPWH**

DPWH will implement the Feasibility Study on the Completion of Metro Manila Circumferential Road 5 and Other Priority Road/Interchange Projects and Traffic Mitigation Measure Cum Environmental, Social and Gender Aspects.

These projects are categorized with the following three (3) schemes;

- (a) Construction of missing link sections.
- (b) Construction of flyovers
- (c) Widening of approach section of existing flyover

In view of the above, C-5 improvement projects by the DPWH will not be affected by the proposed flyover projects.

##### **(2) Site Condition and Traffic survey**

Two (2) issues were found during the site investigation and detailed topographic survey which may cause a bottleneck at the intersection of C-5 thru traffic:-

- (a) Carriageway width of C-5 thru traffic is substandard.
- (b) Subtle curve alignments along C-5 thru traffic of both directions were observed around U-turn flyover.

Traffic survey was conducted last March 6 2012. after the opening of the new flyover from global city to north bound of C-5 road. The traffic survey data shows that vehicle passing along U-turn flyover at south side and north side are 25,132 vehicles per day and 18,600 vehicles per day, respectively. The summarized and actual traffic intersection flow graphics are shown in **Figure 4.5-1**.

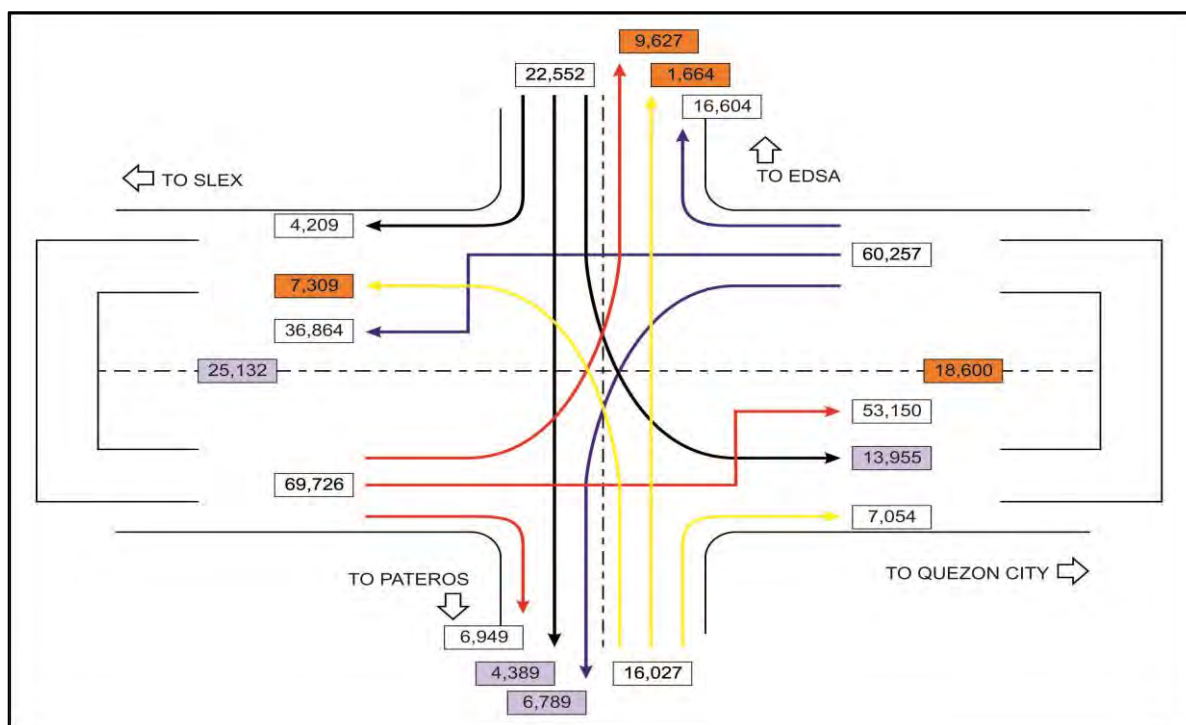

Source: JICA Study Team

**Figure 4.5-1 Summarized Intersection Flow Graphic Summary (AADT)**

**(3) Technical study with maintaining the existing U-turn flyover**

Maintaining the existing U-turn flyover and from the above traffic data, a summary of available options and findings for improving future traffic flows and capacities are shown in **Table 4.5-1**.

**Table 4.5-1 Proposed Options and Findings**

Option	AADT	Findings	Reduced Conflict No. (Present conflict is 5)
1 Construct left turn flyover from Kalayaan Ave. to C-5 north bound	13,955	Require ROW acquisition but Tibagan elementary is located along C-5 north bound.	-2
2 Construct left turn flyover from Pateros to C-5 north bound	7,309	Comparatively traffic volume is small and requires ROW acquisition	-1
3 Construct straight flyover along Kalayaan Ave.	6,053	Traffic volume is small	-1
4 Construct left turn flyover from C-5 south bound to Pateros	6,789	Not enough transition length	-1
5 Construct left turn flyover from C-5 north bound to EDSA	9,627	Not enough transition length	0

Source: JICA Study Team

In view of the above summary, the most effective option is to construct left turn flyover from Kalayaan Ave. to C-5 north direction which noting that the Tibagan elementary school is located just beside the road along C-5 north direction.

**(4) Technical study with demolition of existing U-turn flyover**

The new intersection plans should provide three (3) lanes in each direction with underpass scheme along C-5 thru traffic. Based on the traffic volume and traffic flow at the intersection, the following four (4) schemes can be considered as new potential intersection plans:

- Scheme-1 : Not provide structures for grade separation
- Scheme-2 : Construct 2- Left turn flyover from Kalayaan Ave. to C-5 both direction.
- Scheme-3 : Construct straight flyover along Kalayaan Ave.
- Scheme-4 : Construct 2- Left turn flyover from both direction of C-5 to Kalayaan Ave

Traffic Flow by Scheme is shown in **Figure 4.5-2** and the Scheme Comparison table is presented in **Table 4.5-2**.

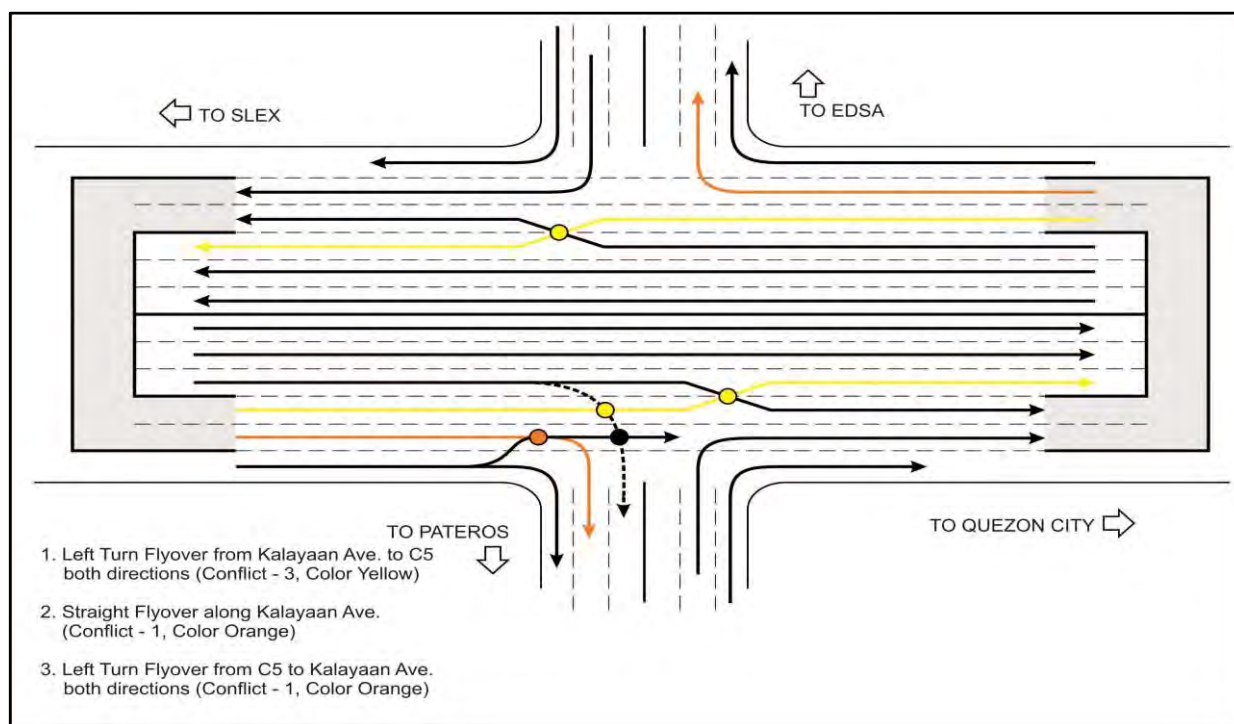

Source: JICA Study Team

**Figure 4.5-2 Traffic Flow by Schemes**

**Table 4.5-2 Scheme Comparison Without U-turn Flyover**

Description	Signal Phase	Traffic Reduction Ratio	Length and Cost of Flyover (m)	Overall Evaluation/Ranking	
<b>Scheme-1</b> No structure for grade separation	4-Phase	$\frac{0}{43.733} = 0\%$	Closed due to confidentiality	* Manage 4-phases signalization  * No cost, no improvement	4
<b>Scheme-2</b> *Left turn flyover from Kalayaan Ave. to C5 both direction	3-Phase	$\frac{21.264}{43.733} = 48.6\%$		* Most effective plan due to almost 50% of traffic is free flow	1
<b>Scheme-3</b> *Straight flyover along Kalayaan Ave.	3-Phase	$\frac{6.057}{43.733} = 13.8\%$		* Requires budget is reasonable but effectiveness to the traffic flow is small	3
<b>Scheme-4</b> *Left turn flyover from C5 both direction to Kalayaan Ave.	3-Phase	$\frac{16.416}{43.733} = 37.5\%$		* 2nd effective plan due to almost 40% of traffic is free flow	2

Note: 1) Traffic rate : Ratio of number of traffic vehicle pass the flyover against total volume of traffic at intersection except along C5 thru traffic and right turn traffic (total volume of traffic for calculation is 43.733 vehicles)

2) Number of lane for all flyover is 2-lane

Source: JICA Study Team

### (5) Overall evaluation

#### With existing U-turn flyover

- Existing substandard carriageway widths and subtle curve alignments are the cause of unsmooth traffic around both sides of the U-turn flyover and a bottleneck for C-5 thru traffic and that remedial solution to these will require demolishing the existing u-turn flyover.
- Most optimum option among the proposed improvement options is the construction of left turn flyover from Kalayaan Ave to C-5 both directions but the existence of the ROW problem should be noted: the Tibagan elementary school is located at just beside of north bound of C-5.

#### Without existing U-turn flyover

- Construction of 3-lanes for each directions with underpass along C-5
- Construction of left turn flyovers from Kalayaan Ave. to C-5 for both directions is the most effective scheme considering that almost 50% of traffic will be free flow
- Estimated cost is as follows:

Construction of 2-lanes Flyover (total length 740m) = MP XXX

Construction of 6-lanes Underpass structure (490m) = MP XXX

Demolition of existing U-turn flyover = MP XXX

Total = MP XXX

**(6) Recommendation**

**With U-turn flyover**

- To find an appropriate solution for ROW problem (Tibagan elementary school) for improvement of the intersection with present condition of U-turn flyover.

**Without U-turn flyover**

- To construct 6-lanes underpass for C-5 thru traffic and 2-lanes left turn flyover from Kalayaan Ave. to C-5 for both directions. Traffic flow system to resolve problems of traffic flow conflict, unsmooth thru traffic alignments and substandard carriageway should also be addressed.

**Total Recommendation**

- Implementation of the above without a U-turn flyover is recommended because the study shows that there is no ultimate solution that could fully address the expected yearly increase traffic without demolition of the existing U-turn flyover.

## 4.6 C-5-GREEN MEADOWS AVENUE

### 4.6.1 Review of Previous Detailed Design

The detailed design of the project was prepared by the Japan Overseas Consultants Co., Ltd. in association with TCGI Engineers in October 2004.

#### (1) Topographic Conditions

There are no significant changes noted in the topographic conditions of the area between the time of the detailed design to the present.

#### (2) Geotechnical Conditions

In the section from Green Meadows to Calle Industria, the subsoil is distributed until the depth of 0.7-1.0m below ground surface. On the other hand White Plains Creek to end section, the subsoil (sandy silt and silty sand) is distributed until the depth of 12.0m below ground surface.

#### (3) Hydrological Conditions

No flooding will be experienced in the proposed area because the elevation of the crossing point with the road is about 5m higher by than the elevation of the confluence with Marikina River.

#### (4) Design Standards

DPWH design standards for highway and flyover were applied.

#### (5) Road Alignment and Structural Conditions

The 925m long cut and cover tunnel will start in front of Green Meadows Avenue intersection and terminate after Eastwood Avenue intersection. The tunnel has four lanes, with two-directionals, and 5.0m vertical clearance.

#### (6) Environmental and Social Conditions

The detailed design did not cover the environmental aspect of the project.

#### (7) Identified Problems and Recommendations

##### **Identified Problems**

- (a) 13m height of sump pit to be located under carriageway and sidewalk will make it hard to arrange or manage traffic during construction.
- (b) There is no study yet on the complicated construction procedure of tunnel underneath the existing creek.

##### **Recommendations**

Based on the problems identified above, careful and thorough study should be undertaken for this improvement option.



#### 4.6.2 Preliminary Design of Interchange

##### (1) Study of White Plains Creek

The proposed inverted siphon cannot be adopted for the following reasons:

(a) Rise in water level at upstream side

The calculation result of the loss of head of inverted siphon is 1.3 m. Therefore, at the time of freshet, the water level will rise to 1.3m higher than the present condition at the upstream side of the road and will cause flooding.

(b) Blockage due to garbage

It is expected that much garbage will flow at the time of freshet because the creek is flowing through a residential area.

##### (2) Comparative Study

The following three (3) alternatives are proposed as the most suitable options for comparison based on site and traffic condition.

- Scheme-1 : 1098m long flyover and Superstructure is PC and RC voided slab
- Scheme-2 : 808m long Cut and cover tunnel
- Scheme-3 : 432m long flyover and 80m long cut and cover tunnel

Among the three (3) schemes, scheme-1 was selected due to following reasons:

- Construction cost is cheaper than other alternatives
- No ROW acquisition
- Construction is much easier than other schemes
- Provide four (4) lanes for each direction at-grade along the total stretch of under viaduct
- Different from other two (2) schemes, specific O&M are not required.

The details of scheme comparison is shown in **Table 4.6-1**

##### (3) Preliminary Design of Selected Scheme

Preliminary design was conducted based on the conditions discussed previously in the comparative study.

**Table 4.6-1 Scheme Comparison Table of C-5 / GREENMEADOWS / ACROPOLIS / CALLE INDUSTRIA INTERCHANGE**

Schemes	SCHEME -1 FLYOVER	SCHEME -2 CUT AND COVER TUNNEL	SCHEME -3 FLYOVER AND CUT & COVER TUNNEL
<b>Structure Schemes</b>	4-Lane Flyover : L= 1098m PC Voided Slab : 6@30m=180.0m RC Voided Slab : 51@18m=918.0m Approach Road : 276.4m	4-Lane Tunnel : 807.7m Approach Road : 513.3m	4-Lane Flyover 3@30m+17@18m=432.0m PC Voided Slab : 3@30.0m=90.0m, RC Voided Slab 19@18.0 m=342.0 m 4-Lane Tunnel : 80m+ Under Pass Section 559.4m Approach Road : 219.6m
<b>Construction Cost</b>	Closed due to confidentiality		
<b>Construction Performance and Duration</b>	24 months ○ No impact on existing creek ○ Construction method and procedure is standard ○ Provide 2-lanes per each direction during construction	38 months ● Requires several construction sequences to maintain creek water flow. ● Requires to find dumping place for 199,000 m <sup>3</sup> of excavated soil ● Require special method and procedure for construction of sump pit and cross pipe about 12 m deep under ground ● Provide 1.5 lane per each direction only during construction	24 months (Tunnel & Flyover Construction Simultaneously) ○ No impact on existing creek ● Requires 2-kind equipments and material for tunnel and flyover construction ● Requires to find dumping place for 62,000m <sup>3</sup> of excavated soil ● Require special construction method and procedure for construction of sump pit and cross pipe about 10 m deep under ground ● Provide 1.5 lane per each direction only during construction
<b>Environmental and Social Conditions</b>	○ No ROW acquisition ● Traffic noise is severe than scheme 3 but not concentrated.	○ Aesthetic view of area will be preserved ● Requires about 400 m <sup>2</sup> ROW acquisition for sump pit ● Greater impact on traffic with longer construction duration ● Noise and exhaust fumes are concentrated at both entrances	● Requires about 400 m <sup>2</sup> ROW acquisition for sump pit location ● Higher volume of exhaust fumes due to longer and steep slope section ● Less traffic noise than Scheme-1 but concentrated at both sides of entrances
<b>Traffic Condition</b>	○ Provide 4-lanes per each direction at grade along entire section of under the viaduct ○ Easiest traffic management during construction	○ Provide 4-lanes per each direction at grade along entire section of tunnel ● Difficult traffic management during construction	● Provide only 2-lanes per each direction at grade tunnel section ● Not advisable for steep slope (4.0%) with 400m long vertical alignment ● Very dangerous at the point of change vertical grade between depressed and elevated
<b>O &amp; M</b>	○ No specific O & M required	● Requires daily monitoring and maintenance for tunnel facilities such as ventilation, water supply, water pump system, fire detection, traffic safety, etc.	● Requires periodic monitoring and maintenance of water pump up system and illumination
<b>Over all Evaluation</b>	○ Cheapest among the schemes ○ No R.O.W. Acquisition ○ Construction is much easier than other 2-schemes  ○ Not require specific O & M compared to other two schemes ○ Provide 4-lanes at-grade per each direction at grade	● Most expensive ● Longest Construction duration ● Difficult construction activity due to existing creek and sump pit  ● Requires permanent O & M system ○ Provide 4-lanes at grade per each direction	● About 12% Expensive than Scheme-1 ● Sump Pit requires difficult construction method and sequence ● Requires 400 m <sup>2</sup> R.O.W. acquisition and periodic monitoring, maintenance of water pump-up system and illumination ● Provide only 2-lanes for each direction at-grade tunnel and approach section ● Vertical alignment is very much worse than other 2-Schemes

LEGEND : ○ advantage  
● disadvantage

Source: JICA Study Team

**(4) Construction Plan and Traffic Management during Construction**

Construction plan, PERT/CPM and traffic management has been studied. PERT/CPM shows that construction duration of this flyover is about 24 months.

**(5) Bill of Quantity and Cost Estimate**

Civil Works Cost for C-5/Green Meadows/Acropolis/Calle Industria Interchange has been estimated based on the following factors:

- Unit price used for similar GOP and BOT projects implemented or tendered from 2010-2011 and the one for major item was re-estimated based on 2011 prices.
- Procedures and composition for the derivation of base construction cost, were referred to similar projects.

Estimated cost of this flyover is as follows:

Civil works cost	PhP XXX
Foreign currency	PhP XXX
Local currency	PhP XXX
Tax	PhP XXX

## CHAPTER 5

### PREPARATION OF IMPLEMENTATION SCHEDULE

This Chapter presents the proposed project implementation schedule.

#### 5.1 STUDY OF CONTRACT PACKAGE ARRANGEMENT

The proposed contract packages should be decided considering the size of contract and location of each flyover as follows:

**Package-1:** EDSA/North/West/Mindanao Interchange: XXX million pesos

**Package-2:** C-5/Green Meadows Interchange: XXX million pesos

**Package-3:** EDSA/Roosevelt/Congressional Interchange: XXX million pesos

C-3/E. Rodriguez Interchange was canceled due to conflict with on-going project of Skyway Stage-3.

#### 5.2 STUDY OF CONSULTANCY SERVICES

The consultancy services for MMICP that are required are; Detailed Design Stage (12 months), Tender Assistance Stage (12 months), and Construction Supervision Stage (26 months). The proposed man-month is 118 M/M for Foreign Expert, 469 M/M for Local Expert and 450 M/M for Technical Support staff. Total amount of proposed consultancy cost is XXX pesos (XXX Yen) including 2% contingency.

#### 5.3 PREPARATION OF PROJECT COST INCLUDING RROW COST

Total project cost is XXX million Pesos and loan amount is XXX million Yen, Government of the Philippines equity counterpart is about XXX million Pesos.

RROW shall be acquired for 100 m<sup>2</sup> at the proposed North/Mindanao Interchange and cost is about 4 million pesos which is already included in the above estimated cost. The summary and breakdown of the project cost are shown in **Tables 5.3-1** and **5.3-2**, respectively.

**Table 5.3-1 Summary of Project Cost**

Closed due to confidentiality
-------------------------------

Source: JICA Study Team

**Table 5.3-2 Breakdown of Project Cost**

Closed due to confidentiality
-------------------------------

Source: JICA Study Team

Notes: Implementation of the C-3-E. Rodriguez Interchange was cancelled by the DPWH to give priority to the construction of Skyway Stage 3, second level, along C-3 under BOT scheme.

**5.4 PREPARATION OF THE TOTAL IMPLEMENTATION SCHEDULE CONSIDERING THE PERIOD OF ECC AND RAP APPROVAL AND THE PROCESSING IN NEDA**

Total proposed implementation schedule is shown in **Table 5.4-1**.

**Table 5.4-1 Draft Implementation Schedule of MMICP**

DESCRIPTION	2011		2012		2013		2014		2015		2016		2017		2018	
	JAN	FEB	MAR	APR	MAY	JUN	JUL	AUG	SEP	OCT	NOV	DEC	JAN	FEB	MAR	APR
1. Preparatory Study																
2. Review and Evaluation of EIA/RAP in DENR EMB																
3. Issuance of Environmental Compliance Certificate																
4. Processing in NEDA for Approval																
5. Loan Negotiation Agreement																
6. Loan Agreement																
7. Selection of Consultant (D/D)																
8. Detailed Design																
9. Selection of Consultant (CS)																
10. 1st Contract Package (EDS/AVEST/NORTH/MINDANAO)																
- Bidding																
- Preparation and Approval of Contract Documents																
- Implementation																
10. 2nd Contract Package (C5/GREENMEADOWS)																
- Bidding																
- Preparation and Approval of Contract Documents																
- Implementation																
11. 3rd Contract Package (EDS/AROSEVELT/C5/E. RODRIGUEZ)																
- Bidding																
- Preparation and Approval of Contract Documents																
- Implementation																
12. R.O.W. Acquisition																

Source: JICA Study Team

## 5.5 IDEA AND BASIC CONCEPT FOR STEP SCHEME

### 5.5.1 Possibility of Adoption of STEP Scheme

Taking into account the scheme repayment conditions of ODA loans of both STEP loan schemes and regular loan condition schemes, the total repayment amount of the loan will become the same for both schemes when the loan amount of the STEP scheme is 12% more costly than the regular loan condition scheme. Notwithstanding the above, a project with a lower increase in cost under STEP scheme when compared to regular loan condition scheme is much appreciated by the borrower.

In view of the above, the STEP loan scheme requires proper arrangement that should utilize Japanese technology with lower investment cost as much as possible.

#### (1) Adoption of Japanese Technologies for This Project

The proposed project is to construct flyovers to mitigate traffic congestion at intersections with heavy traffic conditions in urban areas. Therefore, the focus is to minimize impact on traffic during construction and to complete the project within the shortest possible construction duration. Proposed items to investigate under the project to facilitate a STEP loan scheme are the type of flyover superstructure at the intersection and type of retaining wall along the approach sections.

#### (2) Proposal of Steel Box and Slab Type Bridge for the type of superstructure at the Intersection

##### (a) Original Detailed Design

The original detailed design proposed PC voided slab type superstructure at the intersection. This superstructure type is economical type but requires the erection of special type of shoring, scaffolding, form works and dismantling of those materials following construction. Such works will very much adversely influence the traffic flow during construction and be the cause of heavy traffic congestion. (Refer to **Figure 5.5-1** special type of frame support).

Enclosed by red line in the **Table 5.5-1** is the implementation schedule of such an intersection which shows that the installation of the special type of shoring/scaffolding requires 11 months and that there is a need to temporarily close the road to traffic during dismantling of the shoring/scaffolding. In addition there is high risk of damage to the main body of the structure, in the event of vehicle collision with the special type of shoring and scaffolding.

Moreover, this type of special shoring/scaffolding is also at risk of collapse from vibration during the concrete pouring, which will result in serious damage once collapse occurs. (In fact, the same type of frame support suffered collapse during the concrete pouring for the construction of an expressway in Japan).

Table 5.5-1 Implementation Schedule of Original Plan (C-5/Green Meadows)

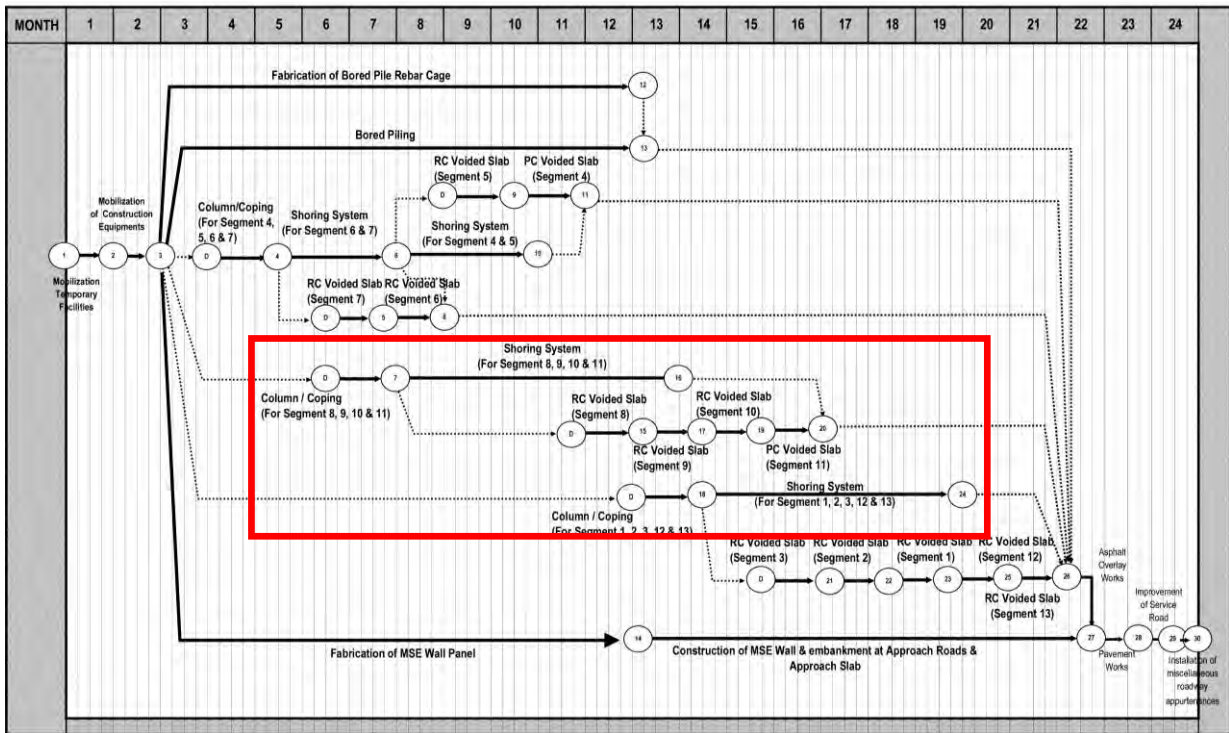

Source: JICA Study Team

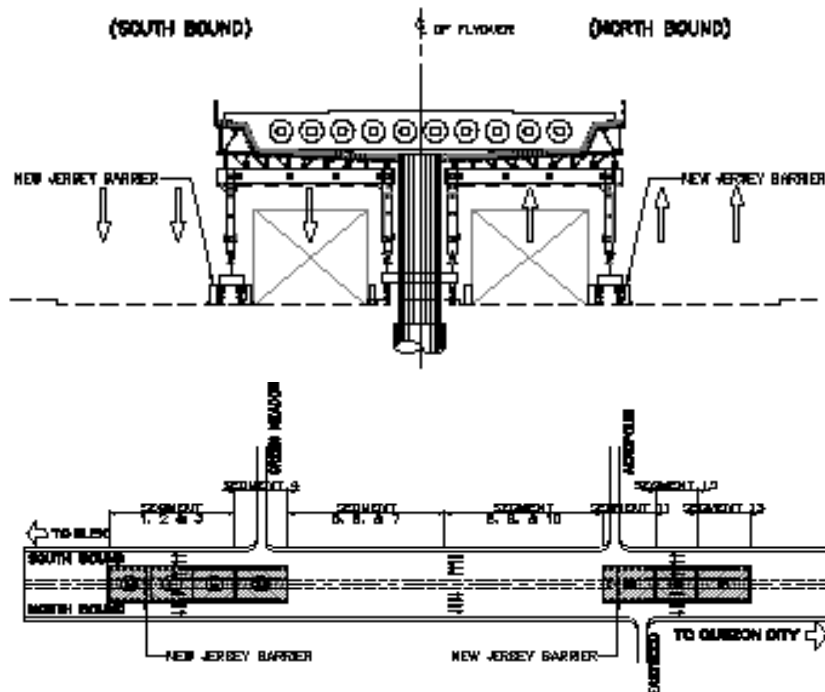

Source: JICA Study Team

Figure 5.5-1 Special Type of Frame Support

(b) Proposal of steel box and steel deck slab type bridge and steel pier

Proposed use of steel bridge, with steel box girder, steel slab deck and steel piers utilizing Japanese technology, as shown in **Figure 5.5-2**, will remove the risks of the original detailed design plan mentioned above and minimize traffic congestion during the construction of superstructure.

➤ Merit of steel box and steel deck slab type bridges

- a. 70m long maximum span steel box and slab type bridge, which is much longer than the 30m long maximum span length of PC voided slab bridge, can provide wider available space for proper arrangement of the at grade intersection.
- b. Affect to existing traffic is only from the girder launching operations during night works given that the steel type structures of the substructure and superstructure are fabricated at off-site yards (refer to **Figure 5.5-3 to 5.5-4**). In addition the erection duration for launching girders is only nine (9) days, indicated by red line in the implementation schedule of the original plan as shown in **Table 5.5-2**. Therefore, the impact on traffic during construction can be minimized.
- c. Construction duration at the site can be minimized to 6.5 months instead of the original plan of 9 months.
- d. Steel box and steel deck slab type bridge is superior to PC voided slab with regard to reduced seismic demand given that steel structures are less heavy.
- e. No concrete slab. The steel deck plate construction is overlaid with guss or stone mastic asphalt as first layer and regular asphalt on top of guss or stone mastick asphalt following launching of the girders.
- f. Allows transfer of Japanese technology.

➤ Demerit of steel box and steel deck slab type bridge

- a. Cannot adopt steel deck form for entire length of flyover given that the steel box and steel deck slab type bridge is more expensive than PC voided slab type.

Comparison between original plan and steel box and slab type bridge is shown in **Table 5.5-3**.



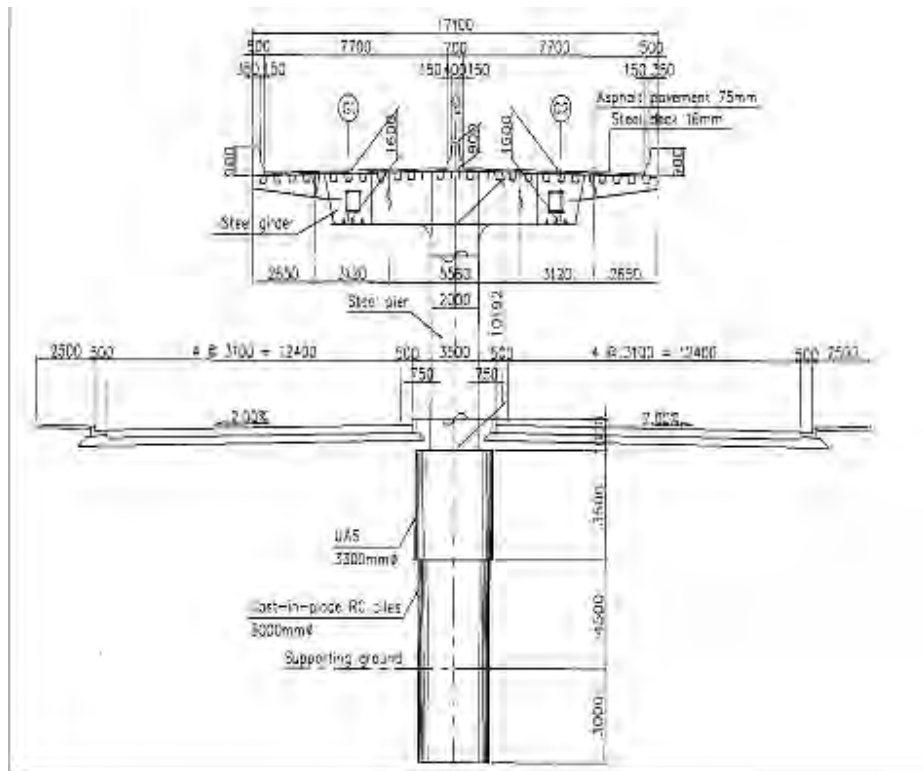

Source: JICA Study Team

**Figure 5.5-2 General View of Steel Box and Slab Type Bridge**

Table 5.5-2 Implementation Schedule of Steel Box and Slab Type Bridge for C5/Green Meadows Interchange

Work Item	Work Scope	Work Days	Month												Remarks																																									
			1			2			3			4																																												
Preliminary		3	5	10	15																																																			
UAS Installation	P11,P12	2																																																						
Bearing Installation	P10,P13	1																																																						
Temporary Props	P10-P11 P12-P13	6																																																						
	P11-P12	3																																																						
Steel Deck Erection	P10-P11 P12-P13	10																																																						
	P11-P12	7																																																						
Steel Pier Erection	P11,P12	1																																																						
Scaffolding	P10-P11 P12-P13	15																																																						
	P11-P12	7																																																						
HCFG Bolt		10																																																						
In Situ Painting & Protection Concrete		18																																																						
Vehicle Crash Barrier		18																																																						
Site Cleaning		4																																																						
Temporary Traffic Arrangement	Day long Arrangement	75																																																						
	Night time Arrangement①	7																																																						
	Night time Arrangement②	2																																																						

Note  
 1)Paving & Piling is excluded  
 2)Downtime of 20% is taken into account

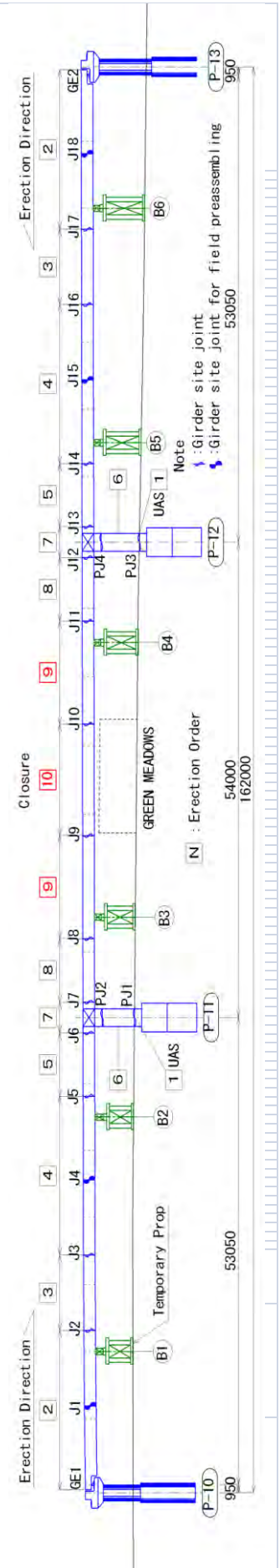

Source: JICA Study Team

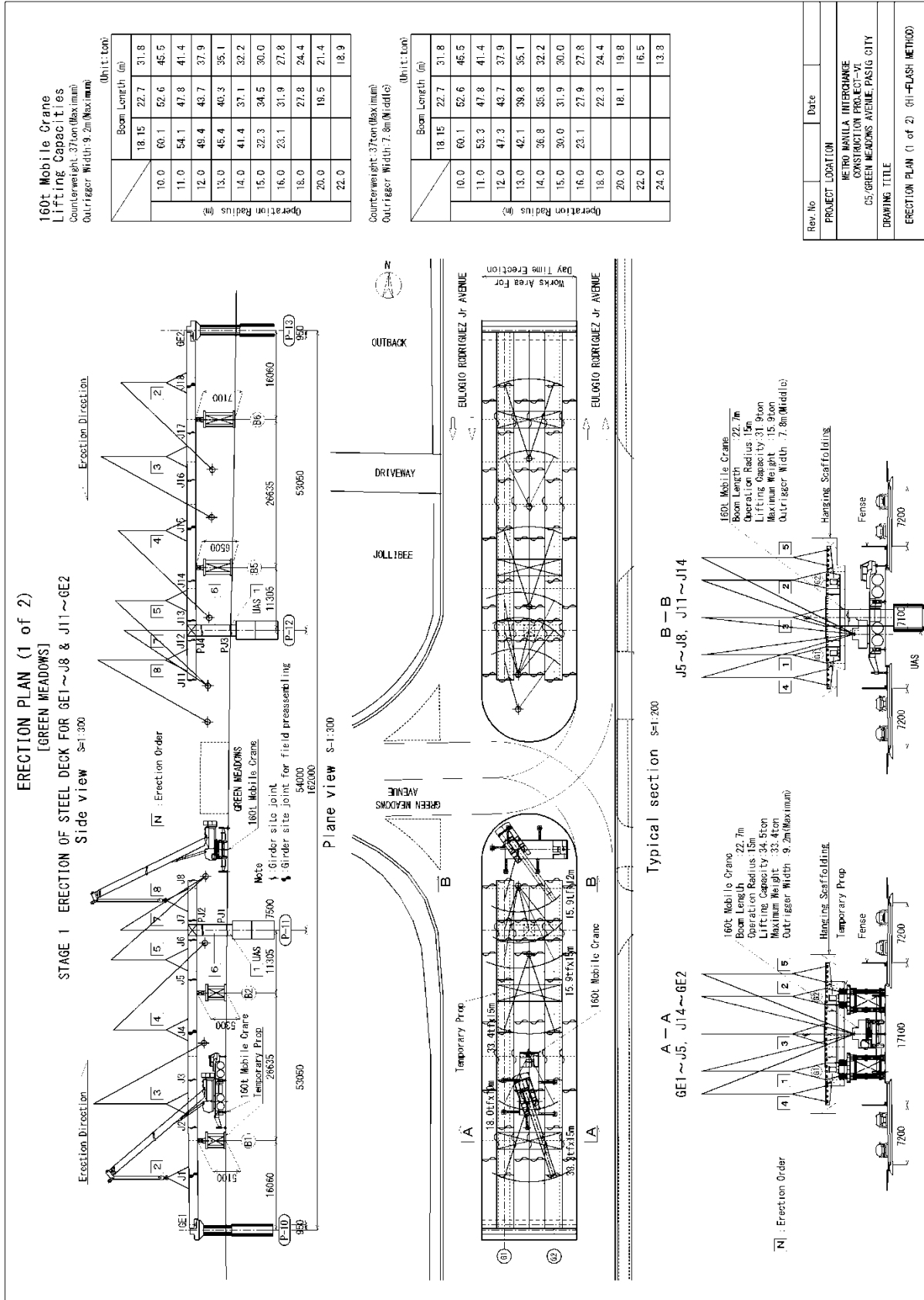

Figure 5.5-3 Elevation Plan (1/2)

Source: JICA Study Team

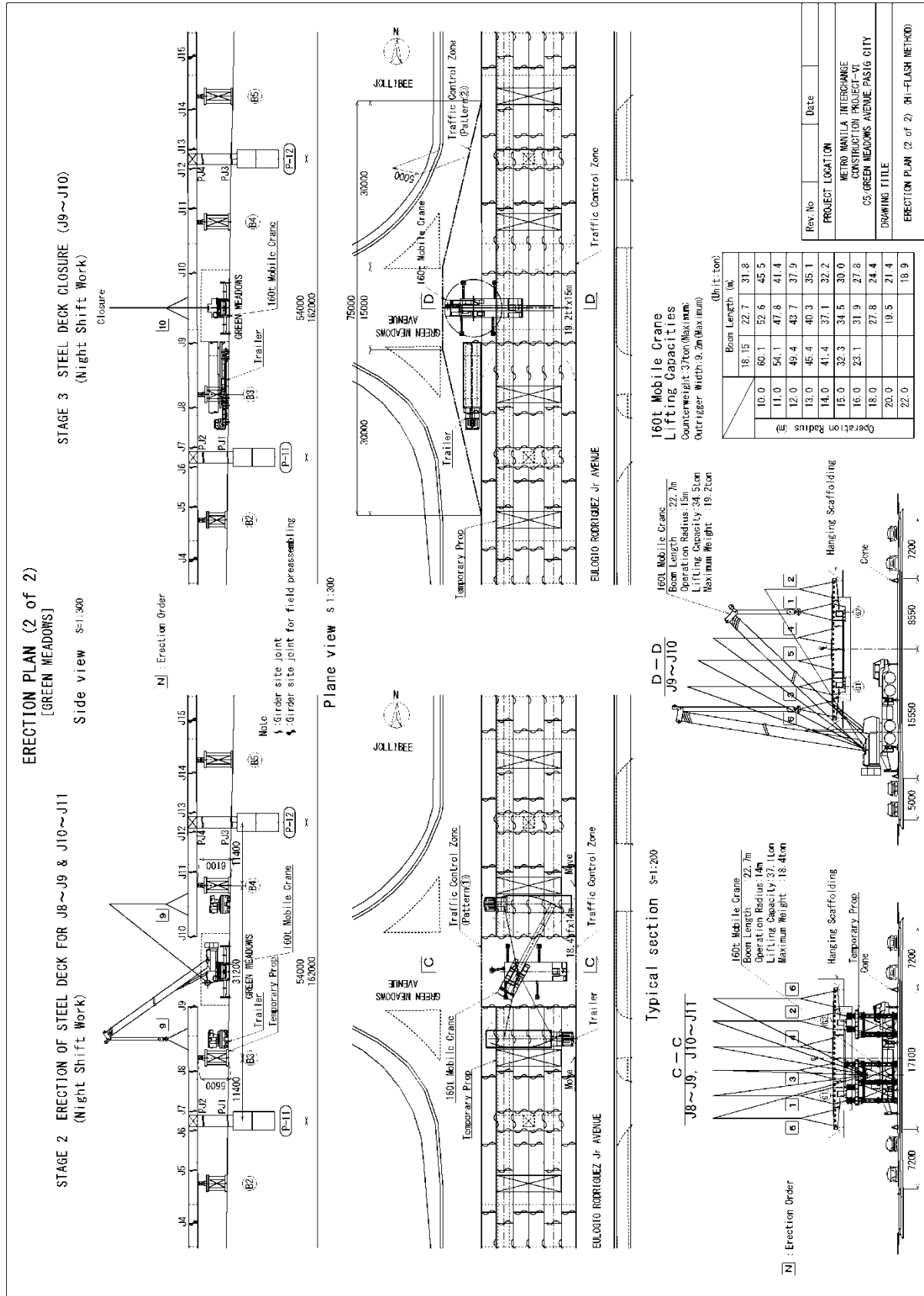

Figure 5.5-4 Elevation Plan (2/2)

Source: JICA Study Team

**Table 5.5-3 Comparison between Original Plan and Steel Box and Slab Type Bridge**

	Steel box and slab type bridge Maximum Span L=70m	Original Plan Maximum Span L=30m
Merit	<ul style="list-style-type: none"> <li>• 70m long maximum span of steel box and slab type bridge is much longer than 30m long maximum span length of PC voided slab which can provide wider available space for proper arrangement of at grade intersection.</li> <li>• Affect to existing traffic is only from launching of girders during night works given that steel type structures of substructure and superstructure are fabricated at off-site yards. In addition the duration of launching girders is only nine (9) days. Therefore, impact on existing traffic can be minimized.</li> <li>• Construction duration at site can be minimized to 6.5 months instead of original plan of 9 month.</li> <li>• Steel box and slab type bridge is superior to PC voided slab with regard to reduced seismic demand given that steel structures are less heavy.</li> <li>• No concrete slab. The steel deck plate construction is overlaid with guss asphalt as first layer and regular asphalt on top of guss asphalt following launching of the girders.</li> <li>• Allows transfer of Japanese technology.</li> </ul>	<ul style="list-style-type: none"> <li>• Economical given construction cost is lower</li> <li>• Can be constructed by local regular contractor due to common type of super structure.</li> </ul>
Demerit	<ul style="list-style-type: none"> <li>• Cannot adopt steel deck form for entire length of flyover given that the steel box and slab type bridge is more expensive than PC voided slab type.</li> </ul>	<ul style="list-style-type: none"> <li>• Requires erection and dismantling of special type of shoring/scaffolding and formworks for voided slab at the intersection, these activities will affect the existing traffic and cause heavy traffic congestion.</li> <li>• The erected shoring/scaffolding will reduce the number of available traffic lanes which will cause heavy traffic congestion until the shoring/scaffolding is dismantled.</li> <li>• There is a risk of damage or collapse of the voided slab in the event of passing vehicle collision with the shoring/scaffolding which will result in great damage to the structure.</li> <li>• There is a risk of collapse of the voided slab due to vibration during the concrete pouring leading to loss of stability of the shoring/scaffolding.</li> </ul>
Construction Duration	24 Month	26 Month
Construction Cost	JPMY XXX <1.149>	JPMY XXX <1.000>

Source: JICA Study Team

Note: Not included C3-E. Rodriguez Flyover for Construction Cost

**(3) Proposal for Earthquake Resistant Type Mechanically Stabilized Earth Wall (ERMSE) at the flyover approach section**

Earthquake resistant MSE wall at the flyovers approach sections is proposed instead of the prevailing type MSE wall. This new type MSE wall (ERMSE) provides high seismic resistance utilizing new wide strips and an improved attachment system between the new wide strip and the concrete skin wall. The proposed use of ERMSE is also an opportunity for Japanese technology transfer. The material cost of ERMSE wall is about 5% only of the total Japanese content. The outline of the proposed ERMSE wall is explained below.

New ERMSE wall provides improved effectiveness of embankment reinforcement

(a) Outline of proposed new ERMSE

To improve the reinforcement mechanism inside the embankment with core technology, without change to the exterior appearance of the prevailing type, the system:

- a. Utilizes new wide strip
- b. Utilizes new concrete skin

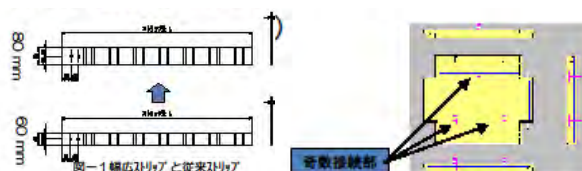

(b) Difference between new type and prevailing type

- a. Improvement of friction resistance and ease of construction. (Prevailing type used 60mm width of strip with ribs.)

The development of 80mm wide strip with ribs improves friction resistance by approximately 30% in comparison with the prevailing type. Construction will also be easier due to the reduction in the number of strips to be installed.

- b. High efficiency in use of material for embankment reinforcement

The strips that connect to the concrete skin with the prevailing type are fixed in four configurations of 4, 6, 8 and 12 pieces. However the new type allows seven configurations with the possibility to also connect 3, 5 and 7 pieces strips. This improves the efficiency of the design and optimizes use of materials.



- c. To improve effectiveness through the combination the above two factors

The proposed ERMSE type provides superior seismic resistance. The effectiveness of this proposed type (no embankment type) was safely confirmed for a similar application during the Higashi Nihon earthquake (Japanese intensity level 6~7).

The construction of ERMSE in urbanized areas is especially effective due to high seismic resistance and attractive appearance. The investigation report shown in **Figure 5.5-5** is one out of 1,423 reports which have confirmed the safety for all of the no embankment type walls.

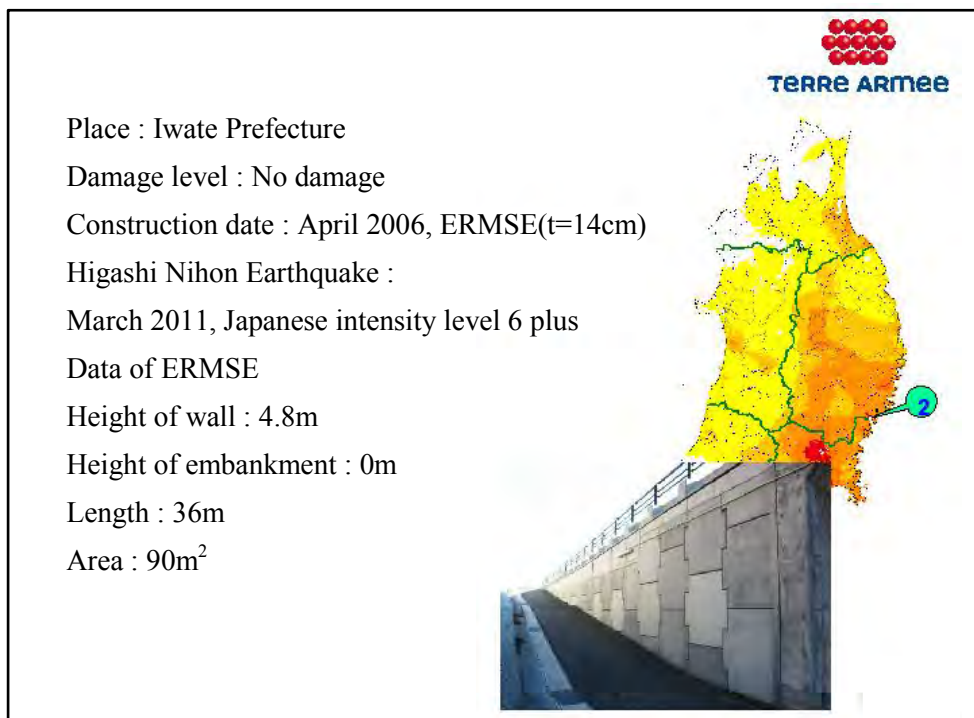

Source: Japan Terre Arme Association

**Figure 5.5-5 Investigation Report**

#### **(4) Achievement of 30% Japanese Content**

##### Japanese content in the Philippines

- ✓ **Cement** : Japanese corporate alliance company Taiheiyo Cement Philippine Inc. is in business in the Philippines.
- ✓ **Reinforcing steel bar** : The Philippines is producing reinforcing steel bars using electric blast furnace methods. However large scale infrastructure projects rely upon imported reinforcing steel bars because of local low production capacity and quality. Japanese Contractor is involved STEP Loan scheme, therefore considering the steel bar to be imported from Japan.
- ✓ **Procurement of structural steel members** (steel box and slab type bridge elements) from Japan. **Materials for high seismic resistance reinforced type ERMSE wall** imported from Japan. **Over head of Japanese contractor (XXX%)**

Amount procured from Japan for the Project is shown in **Table 5.5-4** in the case of procurement of all of the above items.

**Table 5.5-4 Procurement Amount from Japan for the Project**

(Unit: Pesos)

No.	Description	Amount	Percentage (%)
1.	Cement (Material Only)	XXX	XXX
2.	Reinforcing Steel Bar (Material Only)	XXX	XXX
3.	Procurement of structural steel members (Material Only)	XXX	XXX
4.	Structural Steel (Material Only)	XXX	XXX
5.	ERMSE Wall (Material Only)	XXX	XXX
6.	Service of Japanese Contractor	XXX	XXX
	<b>TOTAL</b>	<b>XXX</b>	<b>43.61</b>

Source: JICA Study Team

The total amount of Japanese content, at XXX million yen, is **XXX%** of the total XXX million yen construction cost under STEP scheme. Furthermore, procurement ratio becomes **43.61%** once the **XXX%** of overhead of the Japanese contractor is added. The Japanese content proposed above therefore is adequate to satisfy the required 30% procurement ratio under STEP scheme condition.

### 5.5.2 Advanced Technology and Know-How of Japanese Firms

#### (1) Steel box-girder bridge with steel decks for overpasses at intersections (Non concrete deck slab type)

##### Conventional method for Original Plan

PC voided slab type viaduct at intersection

- ✓ On-site construction work is time consuming as cast-in place concrete is used.
- ✓ Maximum Length of Span is 30m.
- ✓ Construction duration at site is 9 month at intersection site.
- ✓ Required erection and dismantling of special type of shoring/scaffolding and formworks for superstructure construction at intersection and these activities will be affected the existing traffic and cause of heavy traffic congestion
- ✓ The erected shoring/scaffolding will reduce the number of available traffic lanes which will cause of heavy traffic congestion until the shoring/scaffolding is dismantled.
- ✓ There is a risk of damage or collapse of the voided slab in the event of passing vehicle collision with the shoring/scaffolding which will result in great damage to the structure.



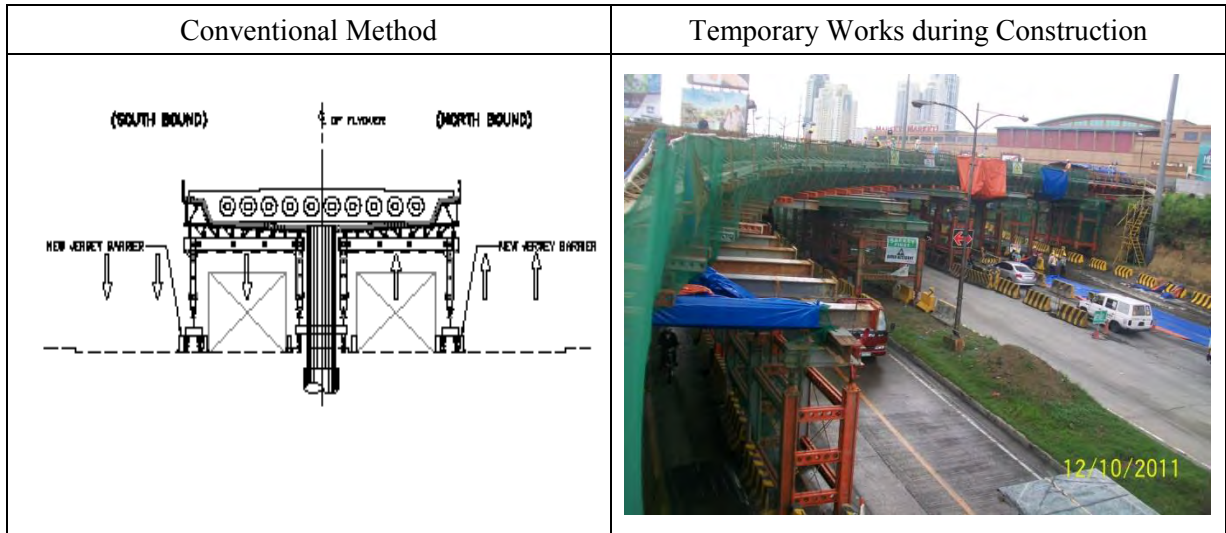

Above cross section and picture is shown for ordinary type of shoring/scaffolding for voided slab.



Above picture is shown for shoring/scaffolding of voided slab during construction for similar project. Traffic lane become 2 lanes from existing 3 lanes and cause of heavy traffic jam during construction



## Proposal method

Rigid-frame box-girder bridge with steel decks and steel Pier at intersection

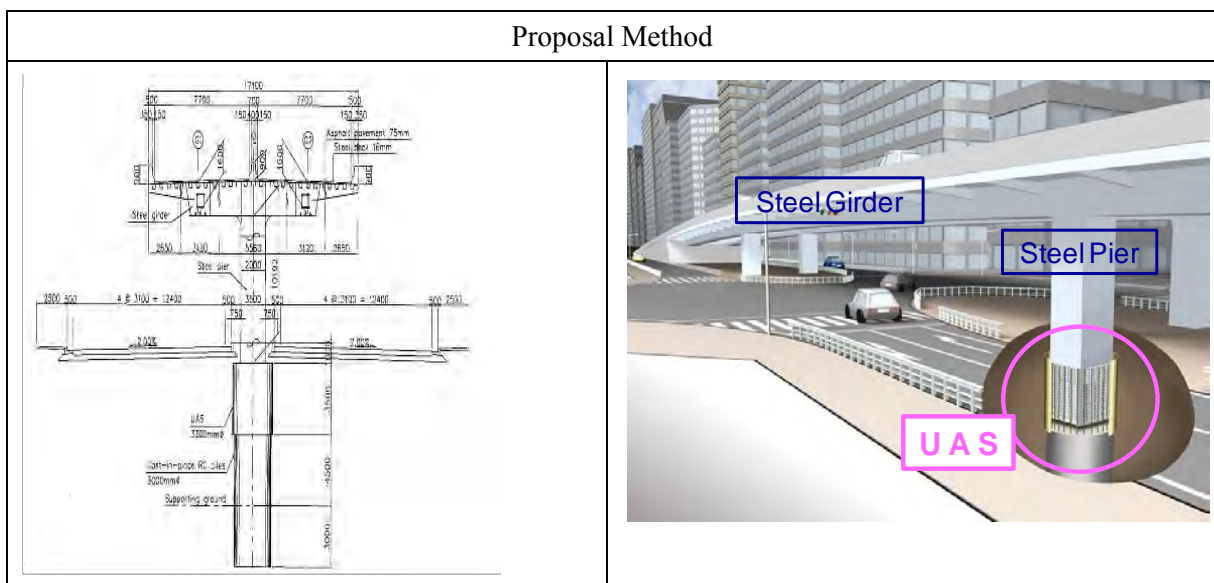
- ✓ Prefabricated steel members mainly used
- ✓ No concrete slab and reduction of dead load. The steel deck plate construction is overlaid with special asphalt such as guss asphalt as first layer and overlaid regular asphalt.
- ✓ Improvement of seismic resistance.
- ✓ Maximum length of span is 70m.
- ✓ Affect existing traffic is only from launching of girders during night time works given that steel substructure and superstructure are fabricated at off-site yards.
- ✓ Duration of launching girders is only 9 days and impact on existing traffic can be minimized
- ✓ On-site construction period is 2.5 months
- ✓ No form works and no shoring/scaffolding after launching girders.
- ✓ Reduction of number of bearings, resulting in maintenance cost and noise reduction



Above cross section and prospective drawing are proposed Rigid Frame Box Girder with Steel Deck and Steel Pire at intersection.

Erection Method	
Day Time	Night Time Erection
	

Above picture is shown for day time and night time condition during erection of superstructure and this erection work is takes only 9 days at intersection.



**(2) Steel piers and connection of pile foundation for Special Method in Japan**

Conventional method

Combination of RC footing and anchor frame as cast-in place concrete is used.

- ✓ On-site construction work is time consuming.
- ✓ Large work yard is required.

Proposal method

UAS (Uni-Anchor System) (Japanese patent technology)

- ✓ UAS is simpler and more compact than the conventional connection system
- ✓ The use of a steel shell reduces the amount of on-site construction work required, such as that involved in form and re-bar assembly
- ✓ Reduction of the on-site construction period and the area of the work yard
- ✓ Squeeze of construction costs

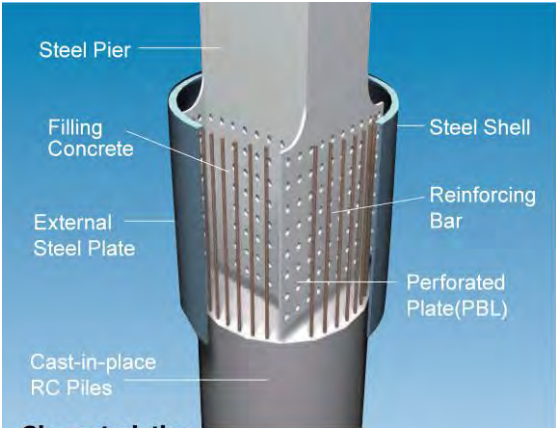
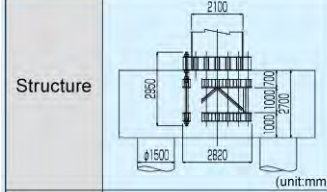
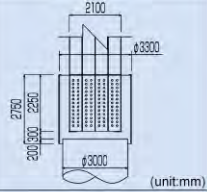
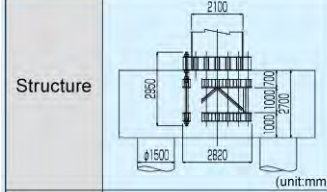
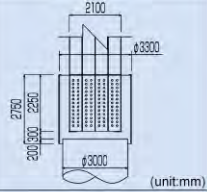
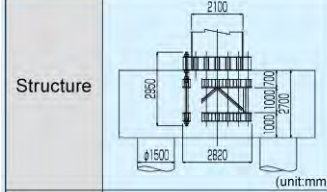
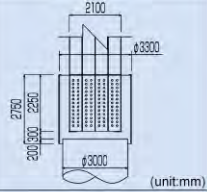
Structure	Comparison of conventional connecting structures																
 <p><b>Characteristics</b></p> <ol style="list-style-type: none"> <li>1. UAS is simpler and more compact than the conventional connecting system.</li> <li>2. The use of external steel plates means that there is no need for hoop bars.</li> <li>3. The use of a steel shell reduces the amount of on-site construction work required, such as that involved in form and re-bar assembly work.</li> <li>4. PBL can reliably transmit the force exerted by the pier on the pile.</li> </ol>	<table border="1" style="width: 100%; border-collapse: collapse;"> <thead> <tr> <th style="width: 10%;"></th> <th style="width: 45%;">Conventional structure (with a footing and an anchor frame)</th> <th style="width: 45%; text-align: center;"><b>UAS</b></th> </tr> </thead> <tbody> <tr> <td style="text-align: center;">Structure</td> <td style="text-align: center;">   (unit:mm)                 </td> <td style="text-align: center;">   (unit:mm)                 </td> </tr> <tr> <td style="text-align: center;">Construction procedure</td> <td style="text-align: center;">                     Piling                      ↓                      Excavation                      ↓                      Foundation cobblestones                      ↓                      Form and re-bar assembly                      ↓                      Anchor frame installation                      ↓                      Reinforcing                      ↓                      Concreting                 </td> <td style="text-align: center;">                     Piling                      ↓                      Steel shell installation                      ↓                      Concrete filling                 </td> </tr> <tr> <td style="text-align: center;">Construction period</td> <td style="text-align: center;"><b>1.0</b></td> <td style="text-align: center;"><b>0.25</b></td> </tr> <tr> <td style="text-align: center;">Construction cost</td> <td style="text-align: center;"><b>1.0</b></td> <td style="text-align: center;"><b>0.75</b></td> </tr> </tbody> </table> <p style="font-size: small;">Note: Numerical figures given in the table are for a four-lane overpass of about 160 meters in length. Actual figures may differ depending on the site conditions.</p>			Conventional structure (with a footing and an anchor frame)	<b>UAS</b>	Structure	 (unit:mm)	 (unit:mm)	Construction procedure	Piling ↓ Excavation ↓ Foundation cobblestones ↓ Form and re-bar assembly ↓ Anchor frame installation ↓ Reinforcing ↓ Concreting	Piling ↓ Steel shell installation ↓ Concrete filling	Construction period	<b>1.0</b>	<b>0.25</b>	Construction cost	<b>1.0</b>	<b>0.75</b>
	Conventional structure (with a footing and an anchor frame)	<b>UAS</b>															
Structure	 (unit:mm)	 (unit:mm)															
Construction procedure	Piling ↓ Excavation ↓ Foundation cobblestones ↓ Form and re-bar assembly ↓ Anchor frame installation ↓ Reinforcing ↓ Concreting	Piling ↓ Steel shell installation ↓ Concrete filling															
Construction period	<b>1.0</b>	<b>0.25</b>															
Construction cost	<b>1.0</b>	<b>0.75</b>															



### 5.5.3 Outline of STEP Scheme

Scope of the works for four intersections under STEP scheme as follows;

#### (1) EDSA-Roosevelt Ave./Congressional Ave.

Structural type : 3 lane individual flyover ( south and north directions are same type and same length)

Span and bridge length :  $7@28.0m+56.0m+58.0m+2@28.0m=366.0m$

Type of flyovers : PC voided slab and Steel box girder

Approach roads : 3 lane and total 207.5m

Pedestrian Bridge : 3 direction (except near side of Munoz station side), total length 95m

RROW : no ROW acquisition

#### (2) EDSA-West Ave./North Ave./Mindanao Ave.

Interchange plan for this intersection will be plan to construct individually due to new plan of MRT-7 station in-front of SM north and new development that Mindanao Ave. direct connected to North Luzon Expressway.

##### (a) EDSA-West Ave./North Ave

Structural type : 3 lane individual flyover (south and north directions are same type but different length)

Span and bridge length : North direction :  $5@28.0m+59.0m+59.0m+3@28.0m=342.0m$

South direction :  $6@28.0m+53.0m+53.0m+2@22.5m=319.0m$

Type of flyovers : PC voided slab and Steel box girder

Approach roads : North direction : 3 lane and total 226.6m

South direction : 3 lane and total 244.6m

RROW : no ROW acquisition

##### (b) North Ave.-Mindanao Ave.

Structural type : North to Mindanao : 2 lane under pass

Mindanao to North : 2 lane flyover

Span and bridge length : North to Mindanao : 95m under pass + 363.5m open cut=458.5m

Mindanao to North :  $6@18.0m+2@60.0m+5@18.0m=318.0m$

Type of flyovers : North to Mindanao : open cut tunnel

Mindanao to North : RC voided slab and Steel box girder

Approach roads : North to Mindanao : included 363.5m of open cut section

Mindanao to North : 2 lane and total 205.4m

RROW: required 100m<sup>2</sup> ROW acquisition at the corner of Veterans Golf Club

**(3) C5-Green Meadows Ave./Acropolis St./Calle Industria St.**

Structural type : 4 lane divided flyover

Span and bridge length:

10@18.0m+3@54.0m+25@18.0m+49.0m+2@50.0m+49.0m+6@18.0m=1,098.0m

Type of flyovers : RC voided slab and steel box girder

Approach roads : 4 lane and total 276.4m

RROW : no ROW acquisition

#### 5.5.4 Estimated Cost

Estimated costs under STEP scheme are shown in **Table 5.5-5** and **Table 5.5-6**.

**Table 5.5-5 Summary of Project Cost (STEP Loan)**

Closed due to confidentiality
-------------------------------

*Source: JICA Study Team*

**Table 5.5-6 Breakdown of Project Cost (STEP Loan)**

Closed due to confidentiality
-------------------------------

*Source: JICA Study Team*

**5.5.5 Draft Estimated Cost for the Consultancy Services for Pre-Construction and Construction Supervision**

Recapitulation of Draft Estimated Cost for the Consultancy Services for Pre-Construction and Construction Supervision is shown in **Table 5.5-7**.

**Table 5.5-7 Recapitulation of Draft Estimated Cost for the Consultancy Services for Pre-Construction and Construction Supervision**

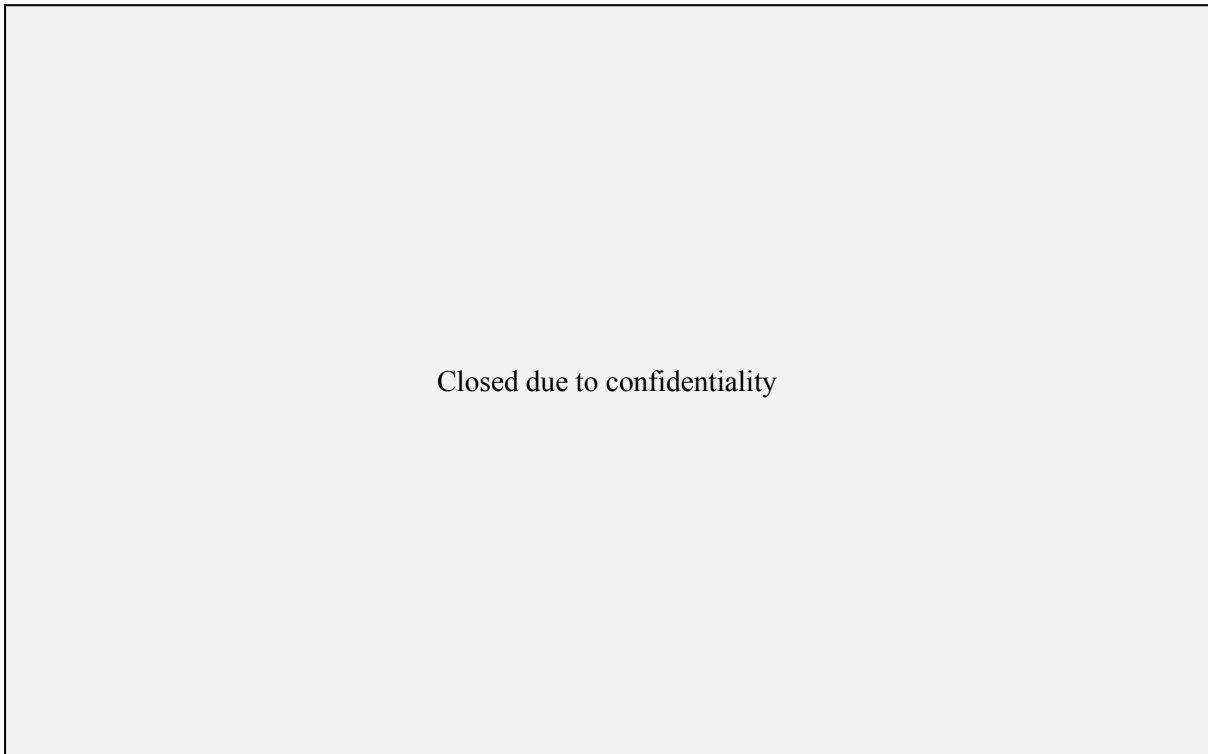

Closed due to confidentiality

*Source: JICA Study Team*



5.5.6 Proposed Implementation Plan (STEP Scheme & General Loan Scheme)

Proposed implementation schedules are shown in Table 5.5-8.

Table 5.5-8 Proposed Implementation Plan (STEP Scheme & General Loan Scheme)

	2013	2014	2015	2016	2017	2018
Pledge	1					
Signing of Loan Agreement	2					
Procurement of DD Consultants (2)						
Detailed Design (12)						
Selection of CS Consultant (12)						
Selection of Contractor (ICB with P/Q) (14)						
- Document creation and JICA Concurrence (3)						
- Prequalification (3)						
- Bidding (2)						
- Evaluation of Bidding Documents (2)						
- JICA Concurrence (1)						
- Negotiation (2)						
- JICA Concurrence on Contract (1)						
Construction Supervision (23)						
Land Acquisition (4)						
Construction						
- EDSA/North-West IC						
- North/Mindanao IC						
- C5/Green Meadows IC						
- EDSA/Roosevelt IC						

Source: JICA Study Team

5.5.7 Proposed Implementation Schedule for Each Interchange

(1) EDSA/Roosevelt/Congressional

Proposed implementation schedule is shown in Table 5.5-9.

Table 5.5-9 Proposed Implementation Schedule for EDSA/Roosevelt/Congressional

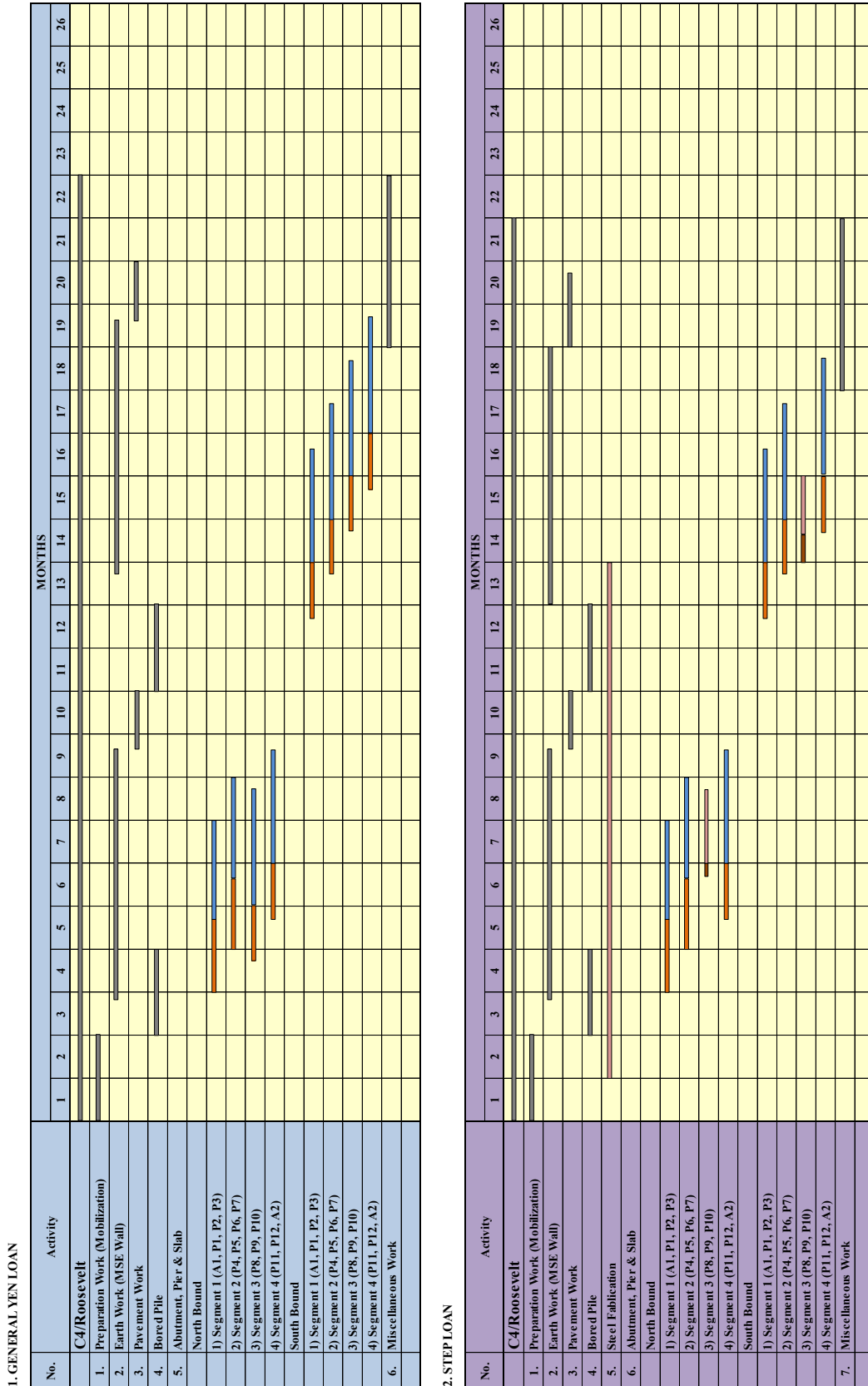

(2) EDSA/North/West

Proposed implementation schedule is shown in Table 5.5-10.

Table 5.5-10 Proposed Implementation Schedule for EDSA/North/West

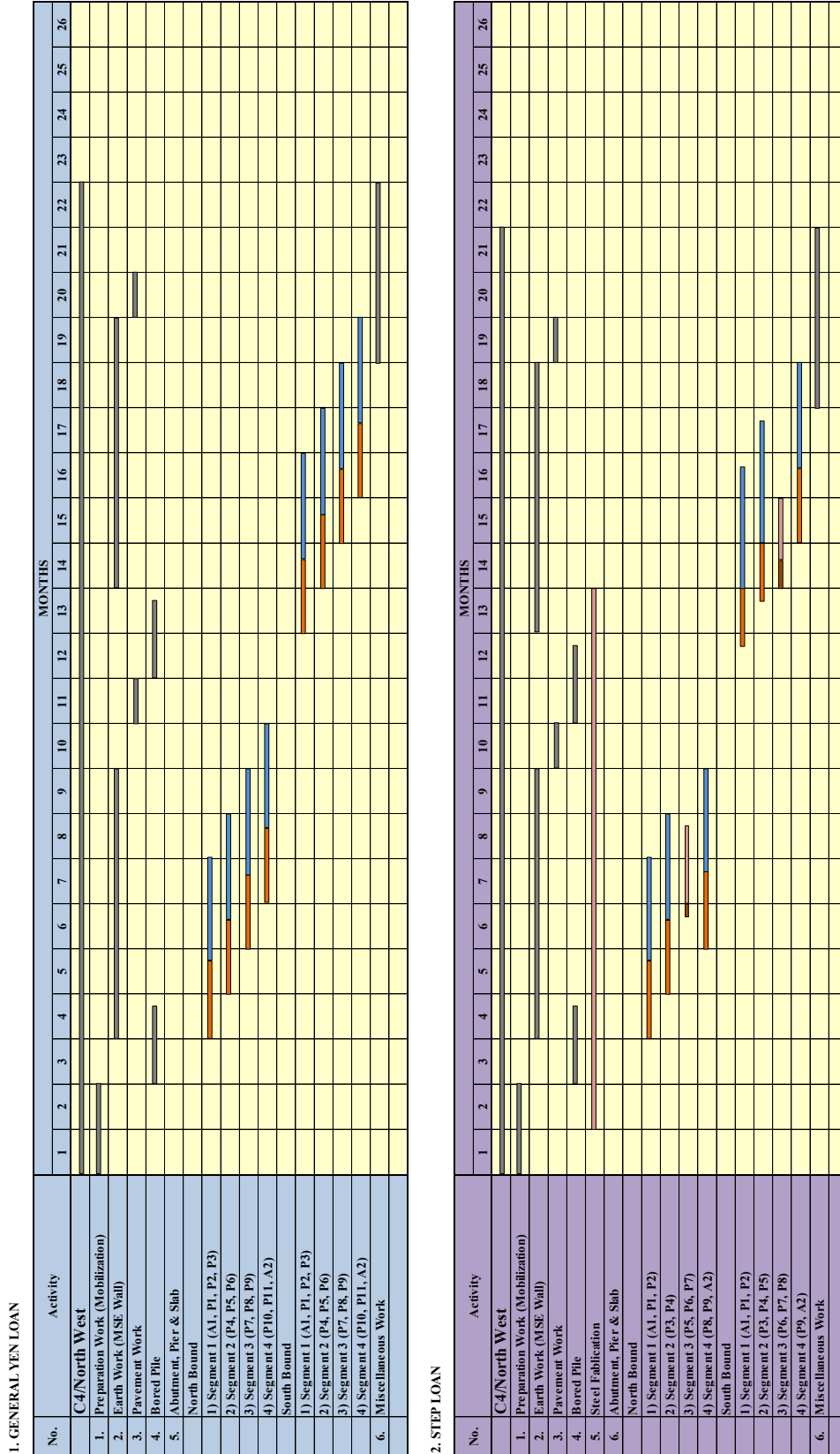

Source: JICA Study Team

(3) West/Mindanao

Proposed implementation schedule is shown in Table 5.5-11.

Table 5.5-11 Proposed Implementation Schedule for West/Mindanao

1. GENERAL YEN LOAN		MONTHS																									
		1	2	3	4	5	6	7	8	9	10	11	12	13	14	15	16	17	18	19	20	21	22	23	24	25	26
No.	Activity																										
<b>North Mindanao</b>																											
1.	Preparation Work (Mobilization)	[Gantt bar from month 1 to 2]																									
2.	Earth Work (MSE Wall)	[Gantt bar from month 1 to 2]																									
3.	Pavement Work	[Gantt bar from month 1 to 2]																									
4.	Bored Pile	[Gantt bar from month 1 to 2]																									
5.	Tunnel, Abutment, Pier & Slab Depressed (Tunnel)	[Gantt bar from month 1 to 2]																									
1)	Bored Pile, Beam & Tunnel	[Gantt bar from month 4 to 5]																									
2)	Excavation	[Gantt bar from month 4 to 5]																									
3)	PC Beam	[Gantt bar from month 4 to 5]																									
Flyover																											
1)	Segment 1 (A1, P1, P2, P3)	[Gantt bar from month 14 to 15]																									
2)	Segment 2 (P4, P5, P6, P7, P8)	[Gantt bar from month 14 to 15]																									
3)	Segment 3 (P9, P10, P11, P12)	[Gantt bar from month 14 to 15]																									
4)	Segment 4 (P13, P14, P15, A2)	[Gantt bar from month 14 to 15]																									
6.	Miscellaneous Work	[Gantt bar from month 14 to 15]																									
<b>2. STEP LOAN</b>																											
No.	Activity																										
<b>North Mindanao</b>																											
1.	Preparation Work (Mobilization)	[Gantt bar from month 1 to 2]																									
2.	Earth Work (MSE Wall)	[Gantt bar from month 1 to 2]																									
3.	Pavement Work	[Gantt bar from month 1 to 2]																									
4.	Bored Pile	[Gantt bar from month 1 to 2]																									
5.	Steel Fabrication	[Gantt bar from month 1 to 2]																									
6.	Tunnel, Abutment, Pier & Slab																										
A.	Depressed (Tunnel)	[Gantt bar from month 4 to 5]																									
1)	Bored Pile, Beam & Tunnel	[Gantt bar from month 4 to 5]																									
2)	Excavation	[Gantt bar from month 4 to 5]																									
3)	PC Beam	[Gantt bar from month 4 to 5]																									
B. Flyover																											
1)	Segment 1 (A1, P1, P2)	[Gantt bar from month 14 to 15]																									
2)	Segment 2 (P3, P4, P5)	[Gantt bar from month 14 to 15]																									
3)	Segment 3 (P6, P17, P8)	[Gantt bar from month 14 to 15]																									
4)	Segment 4 (P9, P10, P11, P12, A2)	[Gantt bar from month 14 to 15]																									
7.	Miscellaneous Work	[Gantt bar from month 14 to 15]																									

Source: JICA Study Team

(4) C5-Green Meadows/Acropolis/Calle Industria.

Proposed implementation schedule is shown in Table 5.5-12.

Table 5.5-12 Proposed Implementation Schedule for C5-Green Meadows/Acropolis/Calle Industria



Source: JICA Study Team

### 5.5.8 Summary of Comparison between STEP Loan and Regular Yen Loan

The characteristics and advantages of both types of loans are shown in the table below.

Description		STEP Loan	Regular Yen Loan	Remarks
1. Bridge Type		PC Voided Slab Bridge + Steel Box and Steel Deck-Slab Bridge	PC Voided Slab Bridge	
2. Total Construction Cost		Closed due to confidentiality		
3. EIRR (%)	EDSA/North/West			
	North/Mindanao			
	EDSA/ Roosevelt			
	C-5/Greenmeadows			
4. Construction Duration (per Flyover)		22~23 months	23~24 months	Reduce 1 month
5. Period of Traffic Control at Intersection		10 days	270 days	
6. Detailed Design		Under JICA Grant	Under Loan	Estimated Detailed Design Cost is PHP XXXM
7. Interest Rate of Loan		0.2% p.a.	1.4% p.a.	
8. Grace Period and Repayment Duration		10 years and 40 years	7 years and 30 years	

Initial investment is high under STEP loan and, correspondingly, low EIRR, but it has the following advantages:

- (a) Relatively shorter duration of construction per flyover;
- (b) Traffic control at intersection is much shorter;
- (c) PHP XXX M estimated cost of detailed design will be undertaken under JICA Grant;
- (d) Very low and fixed interest rate (0.2%) and long-term repayment period.

## CHAPTER 6

### EVALUATION OF PROJECT EFFECTIVENESS

#### 6.1 QUANTITATIVE ANALYSIS OF PROJECT EFFECTIVENESS

Economic analysis of the 4 intersections (five interchanges), namely, C-3/E. Rodriguez, EDSA-Roosevelt, EDSA-North/West, North/Mindanao, C-5/Green Meadows, and the aggregate taken as a whole package have been undertaken with EIRR and ENPV as efficiency measurement indicators. However, implementation of the C-3/E. Rodriguez was cancelled by the DPWH to give priority to the construction of Skyway Stage 3, second level, along C-3 under BOT scheme. Therefore, the aggregate analysis was conducted for four interchanges except C-3/E. Rodriguez. Conversion factors to estimate economic costs and unit prices of vehicle operation cost (VOC-Running and Time costs, DPWH 2008) have been applied as analytical tools for costs and benefits (as per 2012 price level). Sensitivity analysis and shadow pricing were also undertaken to qualitatively assess the allocative efficiency of scarce resources in the economy with the improvement of the concerned interchanges. Sensitivity analysis for the two types of Japan ODA loans will follow in **Sections 6.1.4** and **6.2.4**, respectively.

##### 6.1.1 Analytical Methodology

###### (1) Overall Model Configuration

Economic Internal Rate of Return (EIRR) will be a major index to measure investment feasibility, while taking in view the following prepositions of (i) “**with** and **without**” the project analysis (incremental analysis), (ii) **time discount** method converting all of costs and benefits accrues in the future to the present value, and (iii) **cash-flow analysis**. Variables and assumptive parameters applied to the analysis are summarized in the following set of model configuration-presented in **Table 6.1-1**.

**Table 6.1-1 Model Configuration**

	Variables	C-3/E. Rodriguez	EDSA/ Roosevelt	EDSA/North/ West	North/Minda nao	C-5/Green Meadows
1	Project Life (construction years)	25 (6)				
2	Exchange rate (JPY/PhP)	1.87				
3	Exchange rate (PhP/EUR)	58.5				
4	Physical Contingency (%)	2.0				
5	Price Contingency (Foreign, %)	2.1 (Nov. 2012, JICA)				
6	Price Contingency (Local, %)	2.6 (Nov. 2012, JICA)				
7	OM cost (% of BC + Phy Con)	0.5 (based on past performance)				
8	Standard Conversion Factor	0.83 (1/1.2)				
9	Economic Feasibility Cut-off Rate	15.0 % (Social Discount Rate)				
<b>Sensitivity Analysis</b>						
10	Benefits	15 percent Downsizing				
11	Costs	15 percent Up				
12	Combination of Benefit and Cost	2 variable-simultaneous simulation				

Source: JICA Study Team

**(2) Economic Benefits (common to every intersection)**

Economic benefit includes (i) Vehicle Operation Cost (VOC): Running cost saving, and (ii) VOC: Time cost saving All the benefits and costs were adjusted to 2012 price level.

The DPWH *Basic Vehicle operation Cost (2008)* based on HDM-4 toolkit (The World Bank, version 2.05 in 2006) was applied to numerate the running and time costs, as guided by DPWH and NEDA procedures. In doing so, 10 types of vehicles in the DPWH basic Vehicle Operation Cost table have been realigned to 6 categories in line with the modeling of traffic and demand analysis in the study. The VOC by vehicle type is given in **Table 6.1-2** below.

**Table 6.1-2 Economic Benefit - DPWH BVOC Table (PhP)**

	Passenger Car	Jeepney	Utility Vehicle	Bus	Truck	Motorcycle
Running Cost (V-km)	8.6	7.1	7.5	23.1	31.6	1.5
Time Cost (V-Hr)	408.4	446.6	154.2	1,669.2	109.7	89.9

Source: DPWH BVOC 2008 and JICA Study Team

The annual investment schedule for all of the intersections had been assumed as shown in **Table 6.1-3**.

**Table 6.1-3 Annual Investment Schedule (%)**

1	2	3	4	5	6
0.26	2.92	1.35	28.35	57.22	9.89

Source: JICA Study Team

Note: 1) Annual investment schedule is made up by allocating the project cost in accordance with the project implementation schedule



**(3) Estimates of Economic Costs and Benefits by Intersection**

**(a) C-3/ E. Rodriguez**

Economic cost and benefit are given in **Tables 6.1-4** and **6.1-5** below. Economic Benefit by value is depicted as **Figure 6.1-2**.

**Table 6.1-4 Financial and Economic Costs of C-3 E. Rodriguez (PhP million)**

Closed due to confidentiality

Source: JICA Study Team

**Table 6.1-5 Economic Benefit - VOC Saved of C-3/ E. Rodriguez (PhP million, 2018-37)**

	Passenger Car	Jeepney	Utility Vehicle	Bus	Truck	Motorcycle	Total
Running Cost Saved (v-km, mil)	9.0	0.0005	1.5	-0.2	0.51	-59.7	
BVOC (PhP/v-km)	8.63	7.05	7.54	23.10	31.58	1.54	
Running Cost saving (PhP mil)	77.8	0.004	11.0	-5.3	16.1	-92.0	7.6
Time Saved (v-hr mil)	10.4	1.5	1.3	0.04	0.5	10.1	23.7
BVOC (k-hr)	408.4	446.6	154.2	1,669.2	109.7	89.9	
Time Cost Saving (PhP mil)	4,230.3	656.3	195.0	69.7	50.3	907.5	6,109.0
Total VOC Benefit	4,308.1	656.3	205.9	64.3	66.4	815.5	6,116.6

Source: JICA Study Team

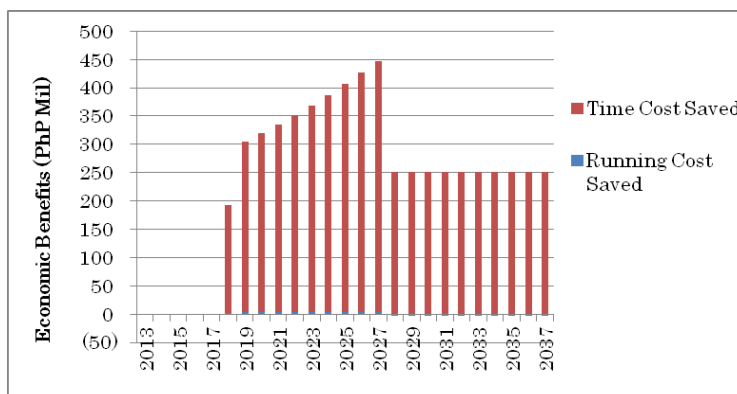

Source: JICA Study Team

**Figure 6.1-1 Economic Benefits by Value of C-3/E. Rodriguez (2018-2037)**

(b) EDSA/Roosevelt/Congressional

Economic cost and benefit are given in **Tables 6.1-6** and **6.1-7** below. Economic Benefit by value is depicted as **Figure 6.1-2**.

**Table 6.1-6 Financial and Economic Costs of EDSA/Roosevelt/Congressional Roosevelt (PhP million)**

Closed due to confidentiality
-------------------------------

Source: JICA Study Team

**Table 6.1-7 Economic Benefit - VOC Saved of EDSA/Roosevelt/Congressional Roosevelt (PhP million, 2018-37)**

	Passenger Car	Jeepney	Utility Vehicle	Bus	Truck	Motorcycle	Total
Running Cost Saved (v-km, mil)	42.3	38.9	6.8	8.1	4.8	12.6	113.5
BVOC (PhP/v-km)	8.63	7.05	7.54	23.10	31.58	1.54	
Running Cost saving (PhP mil)	364.9	274.7	51.2	186.7	152.3	19.4	1,049.3
Time Saved (v-hr mil)	2.8	2.2	0.4	1.0	0.36	0.15	6.9
BVOC (k-hr)	408.4	446.6	154.2	1,669.2	109.7	89.9	
Time Cost Saving (PhP mil)	1,130.1	970.6	60.7	1,682.5	39.7	131.1	3,905.6
Total VOC Benefit	1,495.0	1,254.3	118.5	1,869.2	192.0	32.5	4,954.9

Source: JICA Study Team

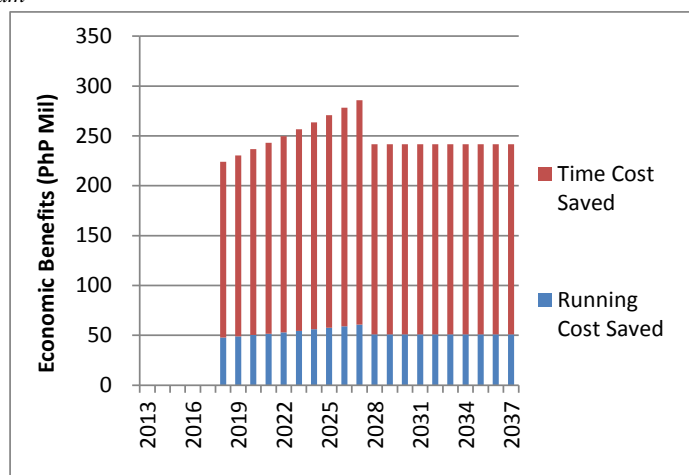

Source: JICA Study Team

**Figure 6.1-2 Economic Benefits by Value of EDSA/Roosevelt/Congressional (2018-2037)**

(c) EDSA/ North/West

Economic cost and benefit are given in **Tables 6.1-8** and **6.1-9**. Economic Benefit by value is shown as **Figure 6.1-3**.

**Table 6.1-8 Financial and Economic Costs of EDSA/ North/West (PhP million)**

Closed due to confidentiality

Source: JICA Study Team

**Table 6.1-9 Economic Benefit - VOC Saved of EDSA/North/West (PhP million, 2018-37)**

	Passenger Car	Jeepney	Utility Vehicle	Bus	Truck	Motorcycle	Total
Running Cost Saved (v-km, mil)	50.8	23.1	10.0	0.9	2.9	7.6	95.22
BVOC (PhP/v-km)	8.63	7.05	7.54	23.10	31.58	1.54	-
Running Cost saving (PhP mil)	438.3	162.7	75.5	19.6	92.7	11.7	800.5
Time Saved (v-hr mil)	15.00	0.96	1.50	0.71	1.94	5.95	26.1
BVOC (k-hr)	408.4	446.6	154.2	1,669.2	109.7	89.9	-
Time Cost Saving (PhP mil)	6,127.2	429.6	231.8	1,183.4	212.8	535.3	8,720.23
Total VOC Benefit	6,565.5	592.3	307.3	1,203.1	305.5	547.0	9,520.7

Source: JICA Study Team

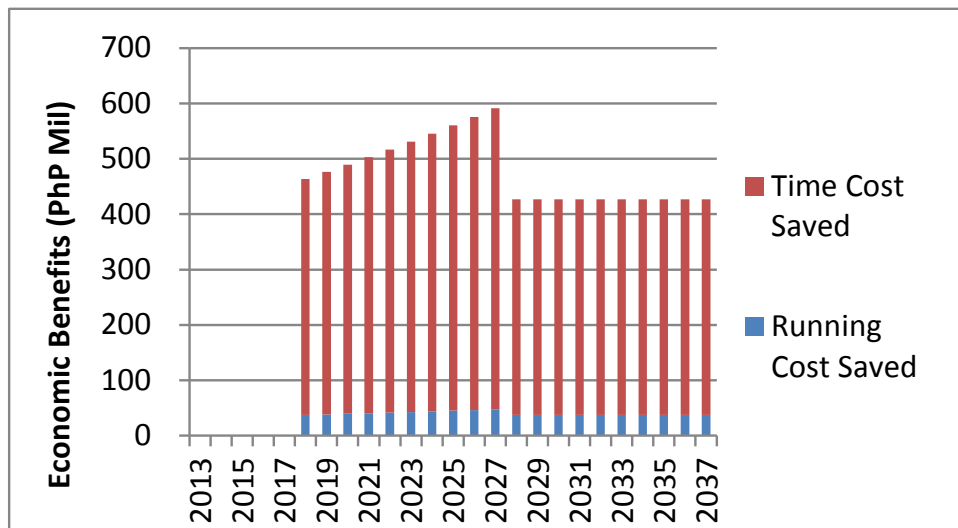

Source: JICA Study Team

**Figure 6.1-3 Economic Benefits by Value of EDSA/North/West (2018-2037)**

(d) North/ Mindanao

Economic cost and benefit are given in **Tables 6.1-10** and **6.1-11**. Economic Benefit by value is shown as **Figure 6.1-4**.

**Table 6.1-10 Financial and Economic Costs of North/ Mindanao (PhP million)**

Closed due to confidentiality
-------------------------------

Source: JICA Study Team

**Table 6.1-11 Economic Benefit - VOC Saved of North/ Mindanao (PhP million, 2018-37)**

	Passenger Car	Jeepney	Utility Vehicle	Bus	Truck	Motorcycle	Total
Running Cost Saved (v-km, mil)	14.3	6.5	2.8	0.2	0.8	2.1	26.9
BVOC (PhP/v-km)	8.63	7.05	7.54	23.10	31.58	1.54	-
Running Cost saving (PhP mil)	123.7	45.9	21.3	5.5	26.2	3.3	225.9
Time Saved (v-hr mil)	4.23	0.27	0.42	0.20	0.55	1.68	7.36
BVOC (k-hr)	408.4	446.6	154.2	1,669.2	109.7	89.9	-
Time Cost Saving (PhP mil)	1,729.2	121.3	65.4	334.0	60.0	151.1	2,461.0
<b>Total VOC Benefit</b>	<b>1,852.9</b>	<b>167.2</b>	<b>86.7</b>	<b>339.5</b>	<b>86.2</b>	<b>154.4</b>	<b>2,686.9</b>

Source: JICA Study Team

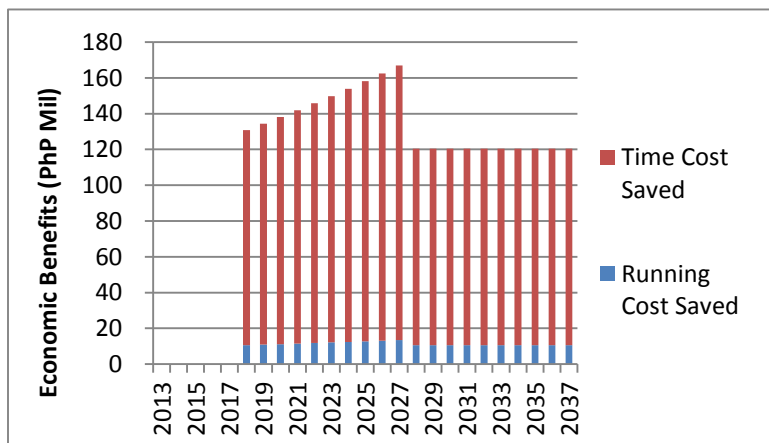

Source: JICA Study Team

**Figure 6.1-4 Economic Benefits by Value of North/Mindanao (2018-2037)**

(e) C-5/Green Meadows

Economic cost and benefit are given in **Tables 6.1-12** and **6.1-13**. Economic Benefit by value is depicted as **Figure 6.1-5**.

**Table 6.1-12 Financial and Economic Costs of Green Meadows (PhP million)**

Closed due to confidentiality
-------------------------------

Source: JICA Study Team

**Table 6.1-13 Economic Benefit - VOC Saved of C-5/Green Meadows (PhP million, 2018-37)**

	Passenger Car	Jeepney	Utility Vehicle	Bus	Truck	Motorcycle	Total
Running Cost Saved (v-km, mil)	60.8	0.7	3.4	0.003	1.7	3.7	70.3
BVOC (PhP/v-km)	8.63	7.05	7.54	23.10	31.58	1.54	-
Running Cost (PhP mil)	524.9	4.8	25.6	0.6	53.1	5.7	614.7
Time Saved (v-hr mil)	12.4	0.9	3.3	0.05	2.2	3.8	22.5
BVOC (k-hr)	408.4	446.6	154.2	1,669.2	109.7	89.9	-
Time Cost Saving (PhP mil)	5,007.4	411.5	510.3	88.0	241.7	341.2	6,600.1
VOC Total Benefit	5,532.3	416.2	535.9	88.6	294.9	346.9	7,214.8

Source: JICA Study Team

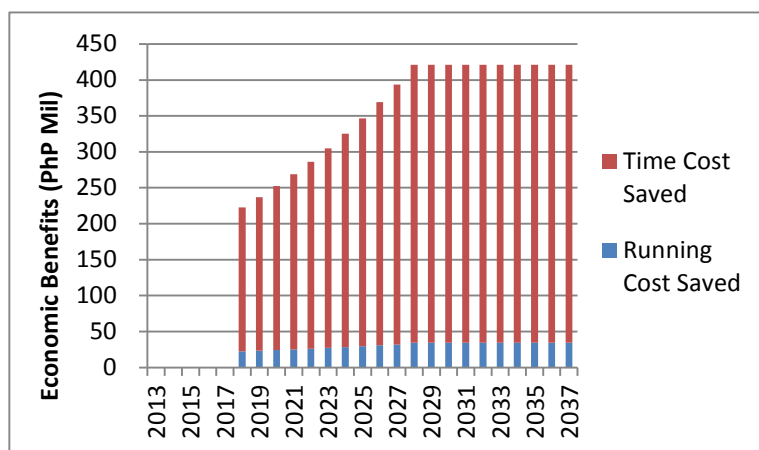

Source: JICA Study Team

**Figure 6.1-5 Economic Benefits by Value of C-5/Green Meadows (2018-2037)**

(f) Aggregate

Implementation of the C-3/E. Rodriguez Interchange was cancelled by the DPWH to give priority to the construction of Skyway Stage 3, second level, along C-3 under BOT scheme. However, the aggregate analysis was conducted for five interchanges including C-3/E. Rodriguez. Aggregate economic costs and benefits are given in **Tables 6.1-14** and **6.1-15**. Economic Benefits by value are shown in **Figure 6.1-6**.

**Table 6.1-14 Financial and Economic Costs: Aggregate (PhP million)**

Closed due to confidentiality	
-------------------------------	--

Source: JICA Study Team

**Table 6.1-15 Economic Benefit - VOC Saved (PhP million, 2018-37)**

	Passenger Car	Jeepney	Utility Vehicle	Bus	Truck	Motorcycle	Total
Running Cost saving (PhP mil)	1,451.8	488.1	173.6	212.5	324.4	40.1	2,690.4
Time Cost Saving (PhP mil)	13,993.9	1,941.9	868.2	3,287.9	554.3	1,040.7	21,686.9
VOC Total Benefit	15,445.7	2,430.0	1,041.8	3,500.4	878.6	1,080.8	24,377.3

Source: JICA Study Team

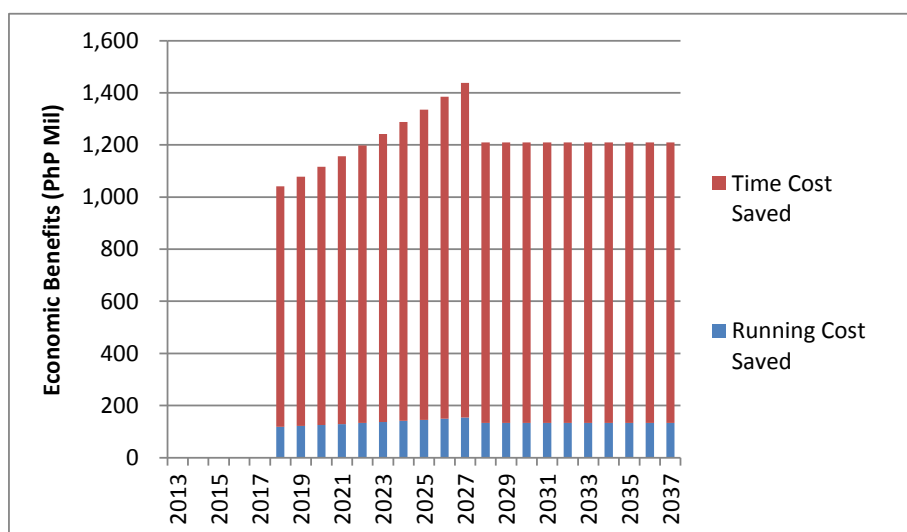

Source: JICA Study Team

**Figure 6.1-6 Economic Benefits by Value (2018-2037)**

### 6.1.2 Results

The Economic Internal Rate of Return (EIRR) and Economic Net Present Value (ENPVs) by intersection are presented in **Table 6.1-16**, followed by figures depicting cost-benefit streams (**Figures 6.1-7 through 6.1-12**). In the estimation of ENPV, a 15 percent social discount rate was applied, as guided by NEDA procedures.

**Table 6.1-16 EIRR and ENPV by Intersection**

	C-3/ E. Rodriguez	EDSA/ Roosevelt	EDSA/North/ West	North/ Mindanao	C-5/Green Meadows	Aggregate <sup>*1</sup>
EIRR (%)	52.2	35.9	68.3	23.4	25.1	41.4
ENPV (PhP mill)	732.6	452.8	1,244.2	147.3	416.4	3124.9

Source: JICA Study Team

Note: 1) Aggregation of three interchanges except C-3/E. Rodriguez.

#### (1) C-3/ E. Rodriguez

EIRR and ENPV stand at XXX percent and PhP XXX million, respectively. The chronological inputs and outputs streams of economic resources are depicted as **Figures 6.1-7**.

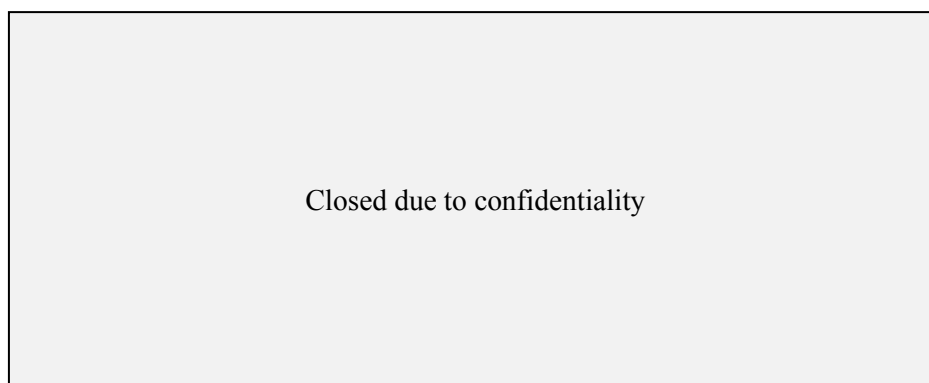

Source: JICA Study Team

**Figure 6.1-7 Cost and Benefit Streams, and EIRR (C-3/E. Rodriguez)**

#### (2) EDSA/Roosevelt/Congressional

EIRR and ENPV were evaluated at XXX percent and PhP XXX million, respectively. It would be noteworthy that the completion of C-3 Expressway (2028) will have little effect on traffic diversion on the concerned intersection. The chronological inputs and outputs streams of economic resources are shown in **Figures 6.1-8**.

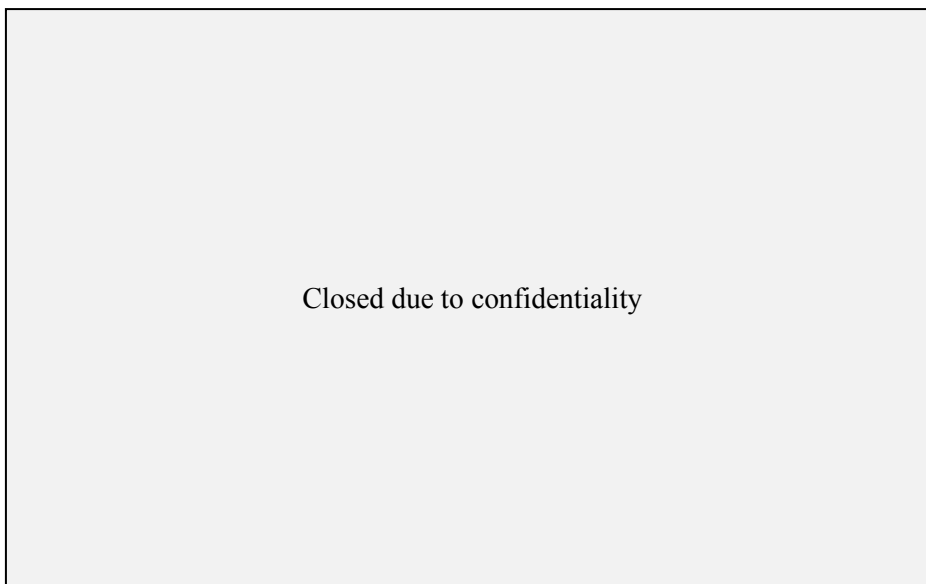

Source: JICA Study Team

**Figure 6.1-8 Economic Cost and Benefit Streams, and EIRR (EDSA/Roosevelt/Congressional)**

**(3) EDSA/North/West**

EIRR and ENPV were evaluated at XXX percent and PhP XXX million, respectively. The chronological inputs and outputs streams of economic resources are shown in **Figures 6.1-9**.

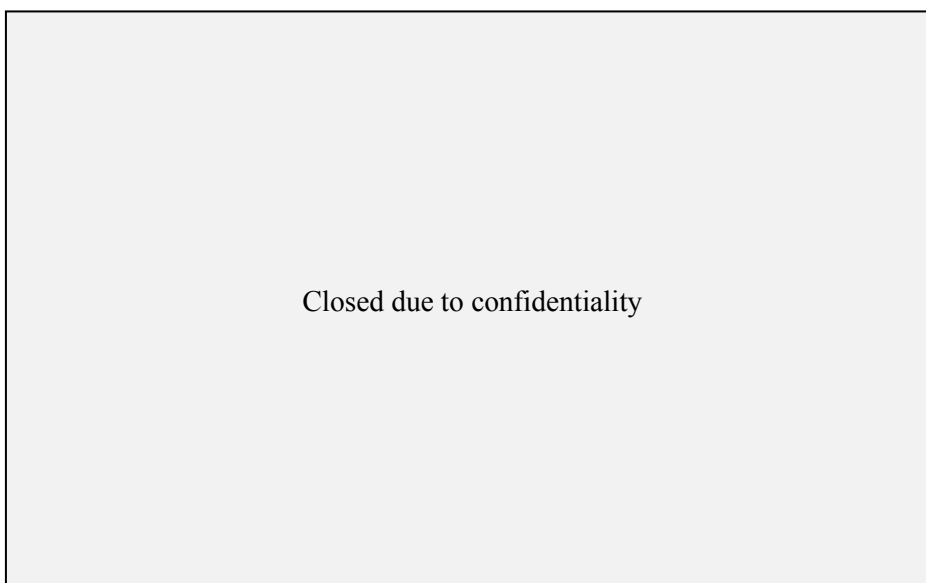

Source: JICA Study Team

**Figure 6.1-9 Economic Cost and Export Parity Benefit, and EIRR  
(EDSA/North/West/Mindanao)**

**(4) North/Mindanao**

EIRR and ENPV were evaluated at XXX percent and PhP XXX million, respectively. The chronological inputs and outputs streams of economic resources are shown in **Figures 6.1-10**.



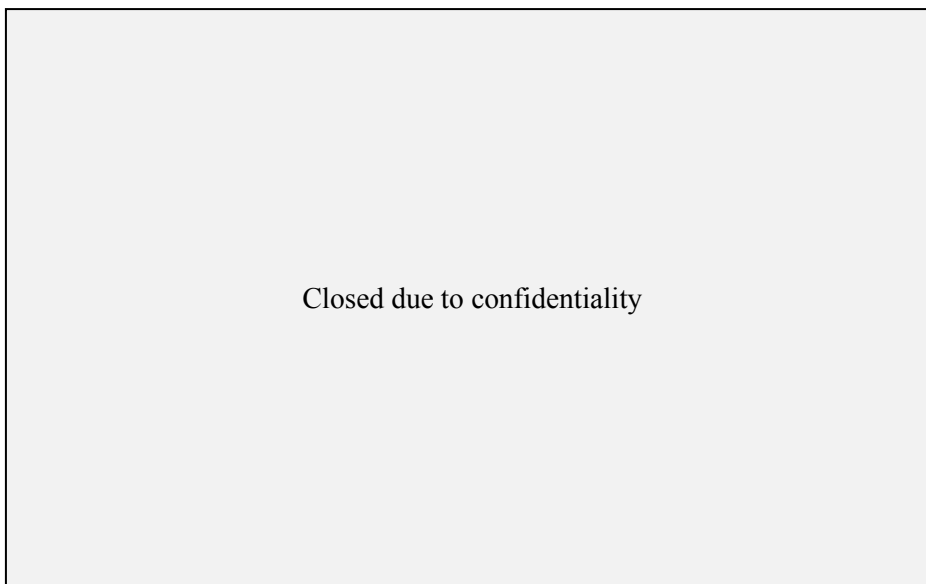

*Source: JICA Study Team*

**Figure 6.1-10 Economic Cost and Export Parity Benefit, and EIRR (North/Mindanao)**

**(5) C-5/Green Meadows**

EIRR and ENPV were evaluated at XXX percent and PhP XXX million, respectively. The chronological inputs and outputs streams of economic resources are shown in **Figures 6.1-11**.

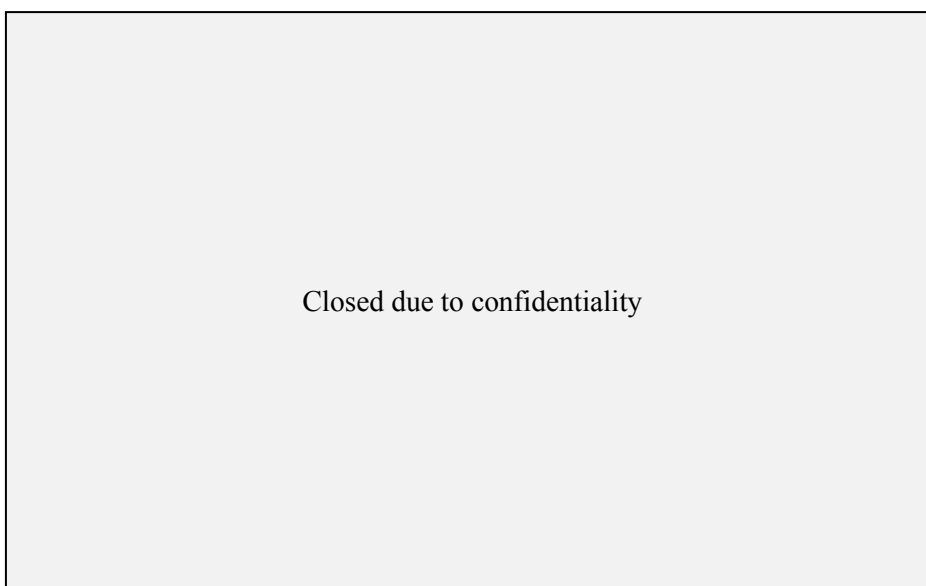

*Source: JICA Study Team*

**Figure 6.1-11 Economic Cost and Benefit Streams, and EIRR (C-5/Green Meadows)**

**(6) Aggregate**

Implementation of the C-3/E. Rodriguez Interchange was cancelled by the DPWH to give priority to the construction of Skyway Stage 3, second level, along C-3 under BOT scheme. Therefore, the aggregate analysis was conducted for three interchanges except C-3/E.

Rodriguez.

Aggregate EIRR and ENPV was estimated at XXX percent and PhP XXX million, respectively. The aggregate chronological streams of economic inputs and outputs and EIRR schedule is shown in **Figure 6.1-12**.

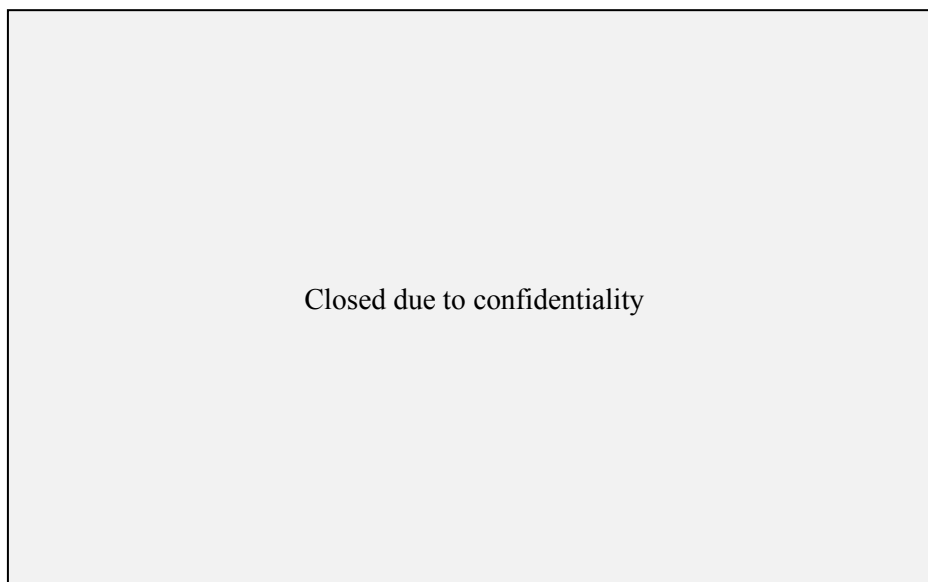

Source: JICA Study Team

**Figure 6.1-12 Cost and Benefit Streams and EIRR**

### 6.1.3 Sensitivity Analysis

Sensitivity analysis has been undertaken to indicate resiliency against risks, specifically, (i) downsizing benefits by 15 percent, (ii) cost increase or overrun by 15 percent, and (iii) combination of (i) and (ii). The results are presented in **Table 6.1-17**. The results reveal profoundly robust viability and resiliency of each of the MMICP against project risks that would take place during their construction and operation period.

**Table 6.1-17 Sensitivity Analysis**

	Base Case	Cost 15% Up	Benefit 15% Down	Combination
C-3/E. Rodriguez	Closed due to confidentiality			
EDSA/Roosevelt				
EDSA/North/West				
North/Mindanao				
C-5/Green Meadows				
Aggregate <sup>*1</sup>				

Source: JICA Study Team

Note: 1) Aggregation of three interchanges except C-3/E. Rodriguez.

### 6.1.4 Conclusion

From the assessments undertaken by the Study Team, all of the intersection construction projects are economically feasible, viable, and highly exceed the cut-off rate of allocative-efficiency of 15

percent. Of this, North-West-Mindanao intersections posted extremely high efficiency rates due largely to (i) large volume of aggregate traffic, (ii) high growth rate of traffic volume<sup>2</sup> (2018-27), and (iii) Low project cost. Major attributes affecting the size of efficiency (EIRR) of each of the intersections are summarized in **Table 6.1-18**.

EIRR analysis and sequential sensitivity analysis numerically proved the worthiness of MMICP in the light of the national economy. As such, the commencement of the project at an early stage of time would profoundly be recommendable by securing the financing facilities inclusive of the Japan's ODA loan as an option.

**Table 6.1-18 EIRR and Attributes of Scarce Resource (2018-37)**

Closed due to confidentiality
-------------------------------

Source: JICA Study Team

## 6.2 EIRR Analysis under STEP Loan Scheme

This section deals with economic analysis of the MMICP under the Japan's STEP loan scheme with EIRR as efficiency measurement index. Analytical framework and methodology are all identical to Japan's Middle Income Countries General Condition Loan (GC) Loan in view. Note that the EIRR analyses assume different initial investment costs under the two loan schemes of GC Loan and STEP Loan. In addition, the implementation of the C-3/E. Rodriguez Interchange was cancelled by the DPWH to give priority to the construction of Skyway Stage 3, second level, along C-3 under BOT scheme.

### 6.2.1 Analytical Methodology

#### (1) Overall Model Configuration

As previously noted in Section 6.1.1, prepositions of the analysis include (i) **“with and without”** the project analysis (*incremental analysis*), (ii) **time discount** method, and (iii) **cash-flow analysis**. Variables and assumptive parameters applied to the analysis are summarized in

<sup>2</sup> Current analysis of demand forecast and sequential efficiency analysis assumes an increase (2018) and downsizing (2028) of traffic volume at each of the intersections taking in view the completion of C-3 missing link construction and C-3 Expressway, respectively. Note that Green Meadows was assumed to have little influence on the C-3 expressway in the light of traffic volume.

**Table 6.2-1.**

**Table 6.2-1 Model Configuration (STEP Loan)**

	Variables	EDSA/ Roosevelt	EDSA/North/ West	North/ Mindanao	C-5/Green Meadows
1	Project Life (construction years)	25 (6)			
2	Exchange rate (JPY/PhP)	1.87			
3	Exchange rate (PhP/EUR)	58.5			
4	Physical Contingency (%)	2.0			
5	Price Contingency (Foreign, %)	2.1 (Nov. 2012, JICA)			
6	Price Contingency (Local, %)	2.6 (Nov. 2012, JICA)			
7	OM cost (% of BC + Phy Con)	0.5 (based on past performance)			
8	Standard Conversion Factor	0.83 (1/1.2)			
10	Economic Feasibility Cut-off Rate	15.0 % (Social Discount Rate)			
	Sensitivity Analysis				
11	Benefits	15 percent Downsizing			
12	Costs	15 percent Up			
13	Combination of Benefit and Cost	2 variable-simultaneous simulation			

Source: JICA Study Team

The annual investment schedule for all of the intersections had been assumed as shown in **Table 6.2-2**.

**Table 6.2-2 Annual Investment Schedule (%)**

1	2	3	4	5	6
1.68	42.37	39.12	6.89	9.94	0.0

Source: JICA Study Team

Note: 1) Annual investment schedule is made up by allocating the project cost in accordance with the project implementation schedule

**(2) Economic Benefits (common to every intersection)**

Economic benefit includes (i) Vehicle Operation Cost (VOC): Running cost saving and (ii) VOC: Time cost saving. All the benefits and costs are as per 2012 price. The VOC by vehicle type is given in **Table 6.1-2**. Meanwhile, the annual investment schedule for all of the intersections had been assumed as same as **Table 6.1-3**.

**(3) Estimates of Economic Costs and Benefits by Intersection**

(a) EDSA/Roosevelt/Congressional

Economic cost and benefit are given in **Tables 6.2-3** and **6.2-4** below. Economic Benefit by value is depicted as **Figure 6.2-1**.

**Table 6.2-3 Financial and Economic Costs of EDSA/Roosevelt/Congressional (STEP Loan, PhP million)**

Closed due to confidentiality

Source: JICA Study Team

**Table 6.2-4 Economic Benefit - VOC Saved of EDSA/Roosevelt/Congressional (STEP Loan, PhP million, 2018-37)**

	Passenger Car	Jeepney	Utility Vehicle	Bus	Truck	Motorcycle	Total
Running Cost Saved (v-km, mil)	42.3	38.9	6.8	8.1	4.8	12.6	113.5
BVOC (PhP/v-km)	8.63	7.05	7.54	23.10	31.58	1.54	
Running Cost saving (PhP mil)	364.9	274.7	51.2	186.7	152.3	19.4	1,049.3
Time Saved (v-hr mil)	2.8	2.2	0.4	1.0	0.36	0.15	6.9
BVOC (k-hr)	408.4	446.6	154.2	1,669.2	109.7	89.9	
Time Cost Saving (PhP mil)	1,130.1	970.6	60.7	1,682.5	39.7	131.1	3,905.6
Total VOC Benefit	1,495.0	1,254.3	118.5	1,869.2	192.0	32.5	4,954.9

Source: JICA Study Team

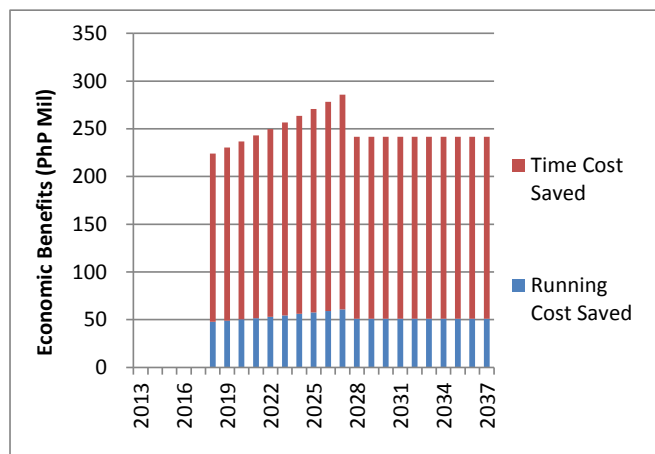

Source: JICA Study Team

**Figure 6.2-1 Economic Benefits by Value of EDSA/Roosevelt/Congressional (STEP Loan, 2018-2037)**

(b) EDSA/ North/West

Economic cost and benefit are given in **Tables 6.2-5** and **6.2-6** below. Economic Benefit by value is depicted as **Figure 6.2-2**.

**Table 6.2-5 Financial and Economic Costs of EDSA/North/West (STEP Loan, PhP million)**

Closed due to confidentiality
-------------------------------

Source: JICA Study Team

**Table 6.2-6 Economic Benefit - VOC Saved of EDSA/North/West (STEP Loan, PhP million, 2018-37)**

	Passenger Car	Jeepney	Utility Vehicle	Bus	Truck	Motorcycle	Total
Running Cost Saved (v-km, mil)	50.8	23.1	10.0	0.9	2.9	7.6	95.22
BVOC (PhP/v-km)	8.63	7.05	7.54	23.10	31.58	1.54	-
Running Cost saving (PhP mil)	438.3	162.7	75.5	19.6	92.7	11.7	800.5
Time Saved (v-hr mil)	15.00	0.96	1.50	0.71	1.94	5.95	26.1
BVOC (k-hr)	408.4	446.6	154.2	1,669.2	109.7	89.9	-
Time Cost Saving (PhP mil)	6,127.2	429.6	231.8	1,183.4	212.8	535.3	8,720.23
Total VOC Benefit	6,565.5	592.3	307.3	1,203.1	305.5	547.0	9,520.7

Source: JICA Study Team

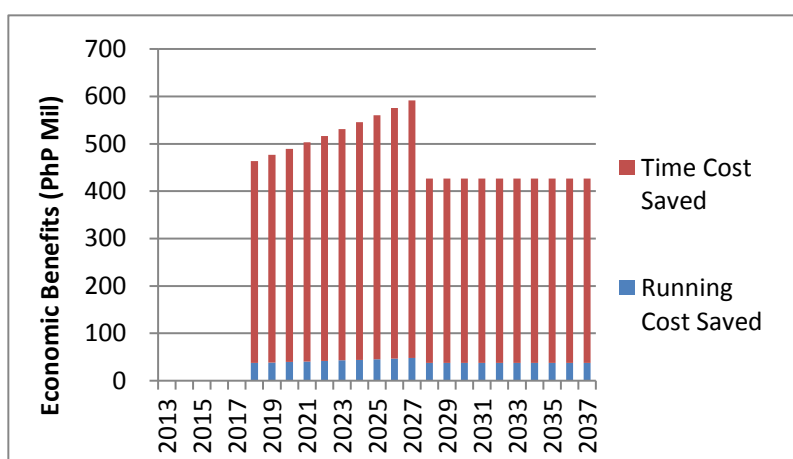

Source: JICA Study Team

**Figure 6.2-2 Economic Benefits by Value of EDSA/North/West (STEP Loan, 2018-2037)**

(c) North/ Mindanao

Economic cost and benefit are given in **Tables 6.2-7** and **6.2-8** below. Economic Benefit by value is depicted as **Figure 6.2-3**.

**Table 6.2-7 Financial and Economic Costs of North/Mindanao (STEP Loan, PhP million)**

Closed due to confidentiality
-------------------------------

Source: JICA Study Team

**Table 6.2-8 Economic Benefit - VOC Saved of North/Mindanao (STEP Loan, PhP million, 2018-37)**

	Passenger Car	Jeepney	Utility Vehicle	Bus	Truck	Motorcycle	Total
Running Cost Saved (v-km, mil)	14.3	6.5	2.8	0.2	0.8	2.1	26.9
BVOC (PhP/v-km)	8.63	7.05	7.54	23.10	31.58	1.54	-
Running Cost saving (PhP mil)	123.7	45.9	21.3	5.5	26.2	3.3	225.9
Time Saved (v-hr mil)	4.23	0.27	0.42	0.20	0.55	1.68	7.36
BVOC (k-hr)	408.4	446.6	154.2	1,669.2	109.7	89.9	-
Time Cost Saving (PhP mil)	1,729.2	121.3	65.4	334.0	60.0	151.1	2,461.0
Total VOC Benefit	1,852.9	167.2	86.7	339.5	86.2	154.4	2,686.9

Source: JICA Study Team

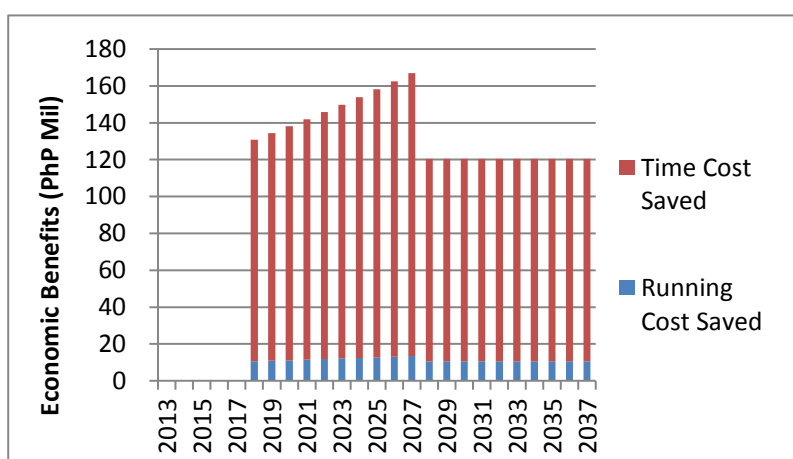

Source: JICA Study Team

**Figure 6.2-3 Economic Benefits by Value of North/Mindanao (STEP Loan, 2018-2037)**

(d) C-5/Green Meadows

Economic cost and benefit are given in **Tables 6.2-9** and **6.2-10** below. Economic Benefit by

value is depicted as **Figure 6.2-4**.

**Table 6.2-9 Financial and Economic Costs of C-5/Green Meadows (STEP Loan, PhP million)**

Closed due to confidentiality
-------------------------------

Source: JICA Study Team

**Table 6.2-10 Economic Benefit - VOC Saved of C-5/Green Meadows (STEP Loan, PhP million, 2018-37)**

	Passenger Car	Jeepney	Utility Vehicle	Bus	Truck	Motorcycle	Total
Running Cost Saved (v-km, mil)	60.8	0.7	3.4	0.003	1.7	3.7	70.3
BVOC (PhP/v-km)	8.63	7.05	7.54	23.10	31.58	1.54	-
Running Cost (PhP mil)	524.9	4.8	25.6	0.6	53.1	5.7	614.7
Time Saved (v-hr mil)	12.4	0.9	3.3	0.05	2.2	3.8	22.5
BVOC (k-hr)	408.4	446.6	154.2	1,669.2	109.7	89.9	-
Time Cost Saving (PhP mil)	5,007.4	411.5	510.3	88.0	241.7	341.2	6,600.1
VOC Total Benefit	5,532.3	416.2	535.9	88.6	294.9	346.9	7,214.8

Source: JICA Study Team

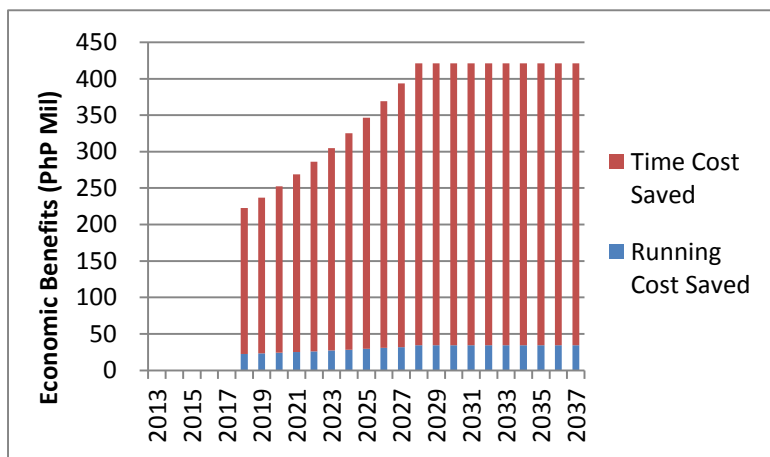

Source: JICA Study Team

**Figure 6.2-4 Economic Benefits by Value of C-5/Green Meadows (STEP Loan, 2018-37)**

(e) Aggregate

Implementation of the C-3/E. Rodriguez Interchange was cancelled by the DPWH to give priority to the construction of Skyway Stage 3, second level, along C-3 under BOT scheme.



Therefore, the following analysis was conducted for aggregation of four interchanges except C-3/E. Rodriguez. Economic cost and benefit are given in **Tables 6.2-11** and **6.2-12** below. Economic Benefit by value is depicted as **Figure 6.2-5**.

**Table 6.2-11 Financial and Economic Costs (STEP Loan, PhP million)**

Closed due to confidentiality
-------------------------------

Source: JICA Study Team

**Table 6.2-12 Economic Benefit - VOC Saved (STEP Loan, PhP million, 2018-37)**

	Passenger Car	Jeepney	Utility Vehicle	Bus	Truck	Motorcycle	Total
Running Cost saving (PhP million)	1,451.8	488.1	173.6	212.4	324.3	40.1	2,690.4
Time Cost Saving (PhP million)	13,993.9	1,933.0	868.2	3,287.9	554.2	1,158.7	21,686.9
VOC Total Benefit	15,445.7	2,421.1	1,041.8	3,500.3	878.5	1,198.8	24,377.3

Source : JICA Study Team

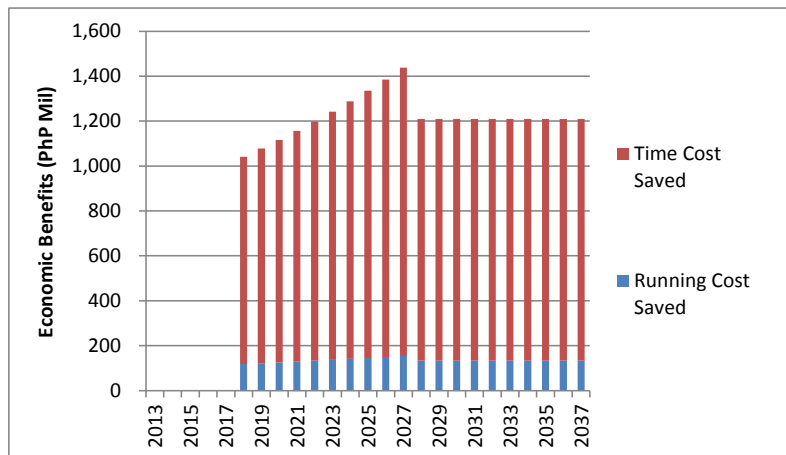

Source: JICA Study Team

**Figure 6.2-5 Economic Benefits by Value (STEP Loan, 2018-2037)**

**6.2.2 Results**

The Economic Internal Rate of Return (EIRR) and Economic Net Present Value (ENPV) by intersection are presented in **Table 6.2-13**, followed by figures depicting cost-benefit streams (**Figures 6.2-6** through **6.2-10**). In the estimation of ENPV, 15 percent of social discount rate was applied, as guided by NEDA.

**Table 6.2-13 EIRR and ENPV by Intersection (STEP Loan)**

	EDSA/ Roosevelt/ Congressional	EDSA/ North/West	North/ Mindanao	C-5/Green meadows	Aggregate <sup>*1</sup>
EIRR (%)	Closed due to confidentiality				
ENPV (PhP mill)					

Source : JICA Study Team

Note: 1) Aggregation of three interchanges except C-3/E. Rodriguez.

(a) EDSA/Roosevelt/Congressional

EIRR and ENPV were figured out at XXX percent and PhP XXX million, respectively. It would be noteworthy that the completion of C-3 Expressway (2028) has little effect of traffic diversion on the concerned intersection. Chronological inputs and outputs of economic resources are depicted as **Figures 6.2-6**.

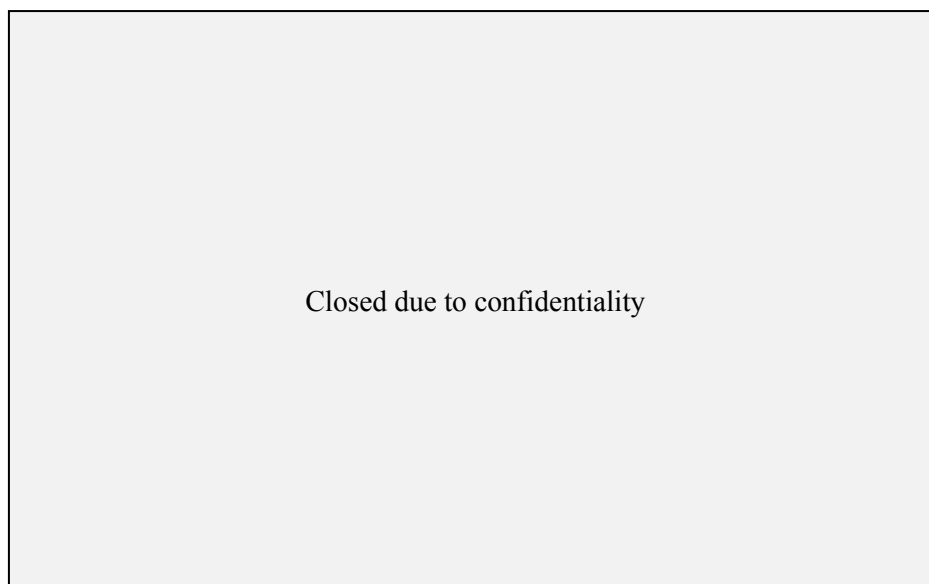

Source: JICA Study Team

**Figure 6.2-6 Economic Cost and Benefit Streams, and EIRR (EDSA/Roosevelt/Congressional, STEP Loan)**

(b) EDSA/ North/ West

EIRR and ENPV were figured out at XXX percent and PhP XXX million, respectively. Chronological inputs and outputs of economic resources are depicted as **Figures 6.2-7**.

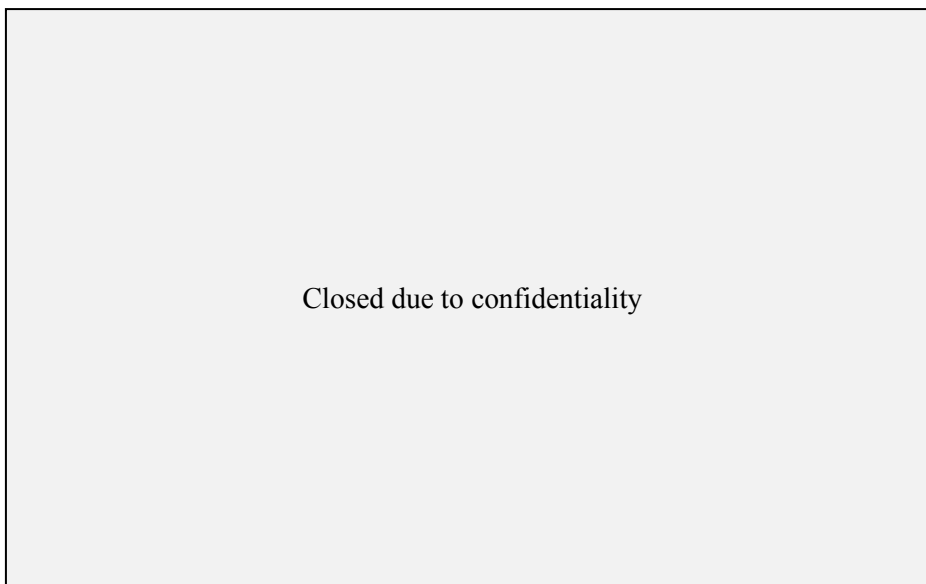

Source: JICA Study Team

**Figure 6.2-7 Economic Cost and Export Parity Benefit, and EIRR  
(EDSA/North/West, STEP Loan)**

(c) North/ Mindanao

EIRR and ENPV were figured out at XXX percent and PhP XXX million, respectively. Chronological inputs and outputs of economic resources are depicted as **Figures 6.2-8**.

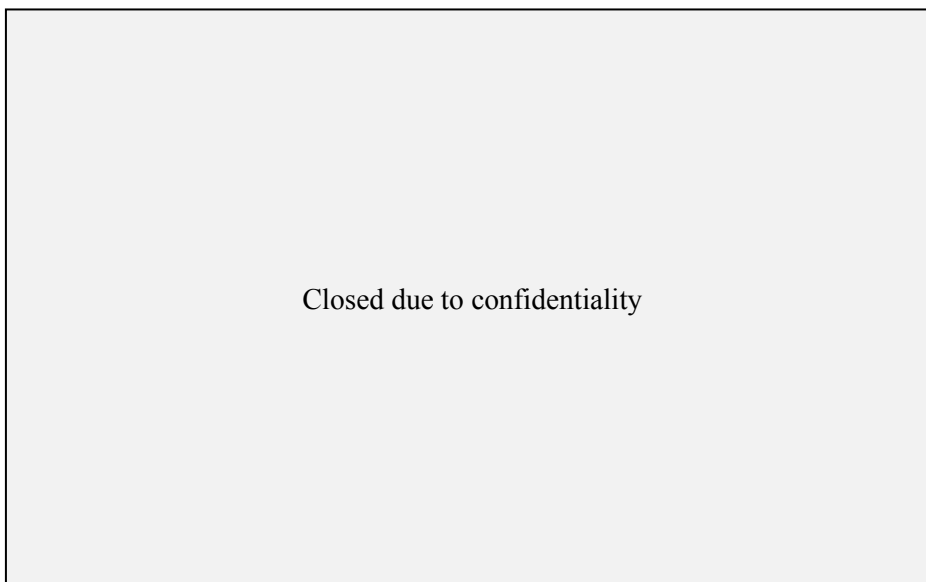

Source: JICA Study Team

**Figure 6.2-8 Economic Cost and Export Parity Benefit, and EIRR  
(North/ Mindanao, STEP Loan)**

(d) C-5/Green Meadows

EIRR and ENPV were figured out at XXX percent and PhP XXX million, respectively. It would be noteworthy that the completion of C-3 Expressway (2028) has little effect of traffic diversion on the concerned intersection. Chronological inputs and outputs of economic resources are depicted as **Figures 6.2-9**.

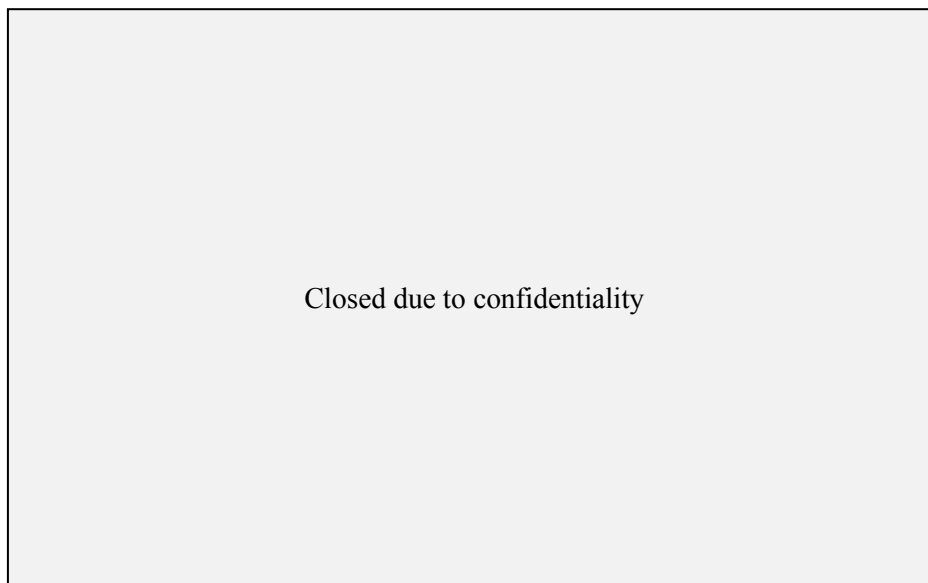

Source: JICA Study Team

**Figure 6.2-9 Economic Cost and Benefit Streams, and EIRR  
(C-5/Green Meadows, STEP Loan)**

(e) Aggregate

Implementation of the C-3/E. Rodriguez Interchange was cancelled by the DPWH to give priority to the construction of Skyway Stage 3, second level, along C-3 under BOT scheme. Therefore, the following analysis was conducted for aggregation of three interchanges except C-3/E. Rodriguez. EIRR and ENPV stood at XXX percent and PhP XXX million, respectively. Chronological economic input and output with EIRR schedule is depicted as **Figure 6.2-10**.

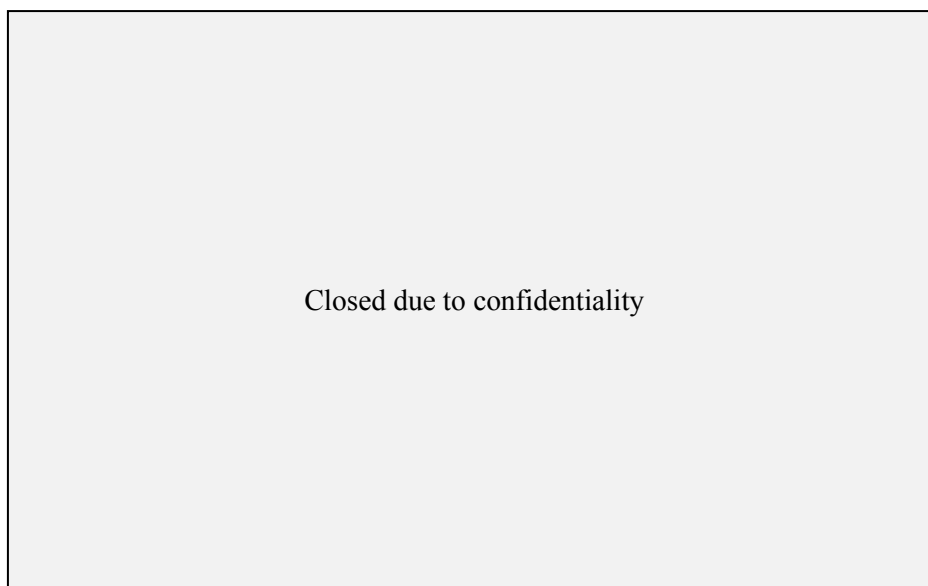

Source: JICA Study Team

**Figure 6.2-10 Cost and Benefit Streams, and EIRR (STEP Loan)**

### 6.2.3 Sensitivity Analysis

Sensitivity analysis has taken place to indicate resiliency of the concerned intersections against risks, specifically, (i) downsizing benefit by 15 percent, (ii) cost overrun by 15 percent, and (iii) combination of (i) and (ii). The results are given below **Table 6.2-14**. The results reveal profoundly robust resiliency of each of the MMICP against project risks that would take place during construction and operation period.

**Table 6.2-14 Sensitivity Analysis (STEP Loan)**

	Base Case	Cost 15% Up	Benefit 15% Down	Combination
EDSA/Roosevelt	Closed due to confidentiality			
EDSA/North/West				
North/Mindanao				
C-5/Green Meadows				
Aggregate <sup>*1</sup>				

Source : JICA Study Team

Note: 1) Aggregation of three interchanges except C-3/E. Rodriguez.

### 6.2.4 Conclusion

EIRR analysis and sequential sensitivity analysis under the STEP loan scheme also numerically proved the worthiness of MMICP in the light of the national economy. As such, the commencement of the project in an early stage of time would profoundly be commendable under the secure financing scheme inclusive of the Japan's ODA loan, either General Condition or STEP loans, as an option.

### 6.3 QUALITATIVE ANALYSIS OF PROJECT EFFECTIVENESS

Primarily, an improved accessibility of transport infrastructure and services at the congested intersections in Metropolitan Manila will by and large benefit road users and surrounding communities. As numerated in the preceding section, road users will benefit directly from reduced vehicle operation cost, shorter travel time, and improved road safety. Likewise, surrounding communities and people therein will also benefit from improved environmental condition brought about by reduction of CO<sub>2</sub> emission and noise. As reflected in Chapter 6 (6.4), these economic benefits will also benefit Japanese companies using traffic networks and intersections in their daily operation of business.

Besides the quantification of VOC, CO<sub>2</sub> emission reduction effects, and improved road safety through the reduction of traffic accidents at the intersections are likewise envisaged. At three of the concerned intersection In Quezon City, fatal and non-fatal injuries, and damages to facilities were recorded at 99, 3,668, and 15,396, in that order<sup>3</sup>. Conservatively assuming rate of accident of the four intersections at 5 percent, and further the cost of traffic accident at around PhP 60,000<sup>4</sup>, the social cost saved by the reduction of traffic accidents would be around PhP 57.5 million per year<sup>5</sup>. This figure, as well as air quality improvements, remains indicative and hence were not used in the quantitative analysis undertaken, Nonetheless, MMICP profoundly implies economic benefits of social cost savings through the reduction of traffic accidents.

Furthermore, with the current management transformation efforts of the DPWH, the project will generate greater economic benefits coming from enhanced DPWH institutional and human resources capacity that will bring about lower cost and better quality of construction and maintenance works for road projects in the future.

### 6.4 OPERATION AND EFFECT INDICATORS

Operation and effect of the Project will be monitored by measuring traffic volume and average travel speed as indicators. The targets of the indicators are estimated as of the planned monitoring timing as shown in **Table 6.4-1** conducting monitoring by DPWH in 2019 two years after completion of the project. **Figure 6.4-1** through **6.4-4** show monitoring location of each intersection.

---

<sup>3</sup> Source: Metro Manila Development Authority (MMDA), Metro Manila Accident Reporting and Analysis System (MMARAS), *Traffic Accident Report January to December 2009*

<sup>4</sup> The World Bank, *The Bank Operation of Project Financing (Japanese)*, 2007, p. 46, The case of PRC

<sup>5</sup>  $(99+3,668+15,396) \times 0.05 \times 60,000 = (\text{around}) \text{ PhP } 57.5 \text{ million}$

**Table 6.4-1 Monitoring Plan Operation and Effect Indicators**

Indicators		Vehicle Type	Base Year (2011)	Target Year* (2019)	Monitoring Location
Traffic Volume (veh/day)	EDSA/Roosevelt/ Congressional Intersection	Car	65,107	69,126	Along EDSA: Cubao Side
		Jeepney	2,302	8,925	
		Utility Vehicle	8,064	6,524	
		Bus	10,134	12,415	
		Truck	7,035	2,968	
		Bicycle	7,171	18,210	
		<b>Total</b>	<b>99,813</b>	<b>118,167</b>	
	EDSA/West/North Intersection	Car	129,372	130,786	Along EDSA: Cubao Side
		Jeepney	2,119	0	
		Utility Vehicle	5,080	6,691	
		Bus	10,432	13,593	
		Truck	8,119	4,211	
		Bicycle	11,259	23,703	
		<b>Total</b>	<b>166,381</b>	<b>178,985</b>	
	North/Mindanao Intersection	Car	43,406	44,645	Along North Ave.: EDSA Side
		Jeepney	12,209	10,963	
		Utility Vehicle	4,240	5,733	
		Bus	58	0	
		Truck	2,089	1,435	
		Bicycle	7,390	13,818	
		<b>Total</b>	<b>69,392</b>	<b>76,593</b>	
	C-5/Green Meadows/ Acropolis/Calle Industria Intersection	Car	77,269	112,519	Along C-5: Pasig City Side
		Jeepney	3,727	5,820	
		Utility Vehicle	14,679	18,539	
Bus		215	524		
Truck		9,765	6,244		
Bicycle		24,785	34,904		
<b>Total</b>		<b>129,440</b>	<b>178,551</b>		
Average Travel Speed in PM Peak (km/h)	EDSA/Roosevelt/ Congressional Intersection		16.2	62.2	Along EDSA: Northbound Flyover
	EDSA/West/North Intersection		19.9	33.6	Along EDSA: Northbound Flyover
	North/Mindanao Intersection		9.8	50.3	Along North Ave.: EDSA Side bound to Quezon Circle
	C-5/Green Meadows/ Acropolis/Calle Industria Intersection		29.3	51.0	Along C-5: Northbound Flyover

\* Target Year is two years after the completion of the Project, which is defined as the time when the Project is open to traffic.

Source: JICA Study Team

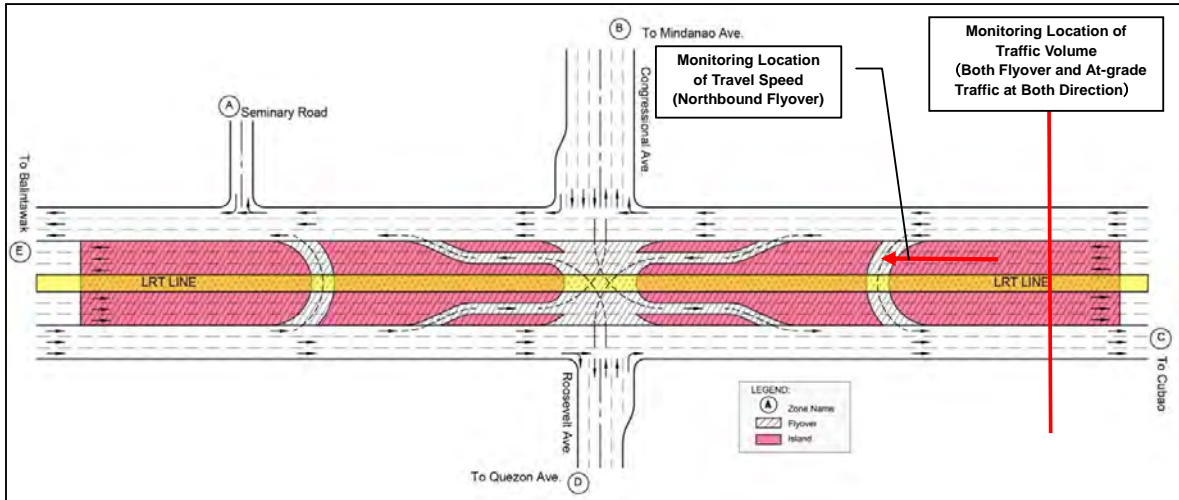

Source: JICA Study Team

**Figure 6.4-1 Monitoring Location for Traffic Volume Count and Travel Speed (EDSA/Roosevelt/Congressional Ave. Intersection: Along EDSA – Cubao Side)**

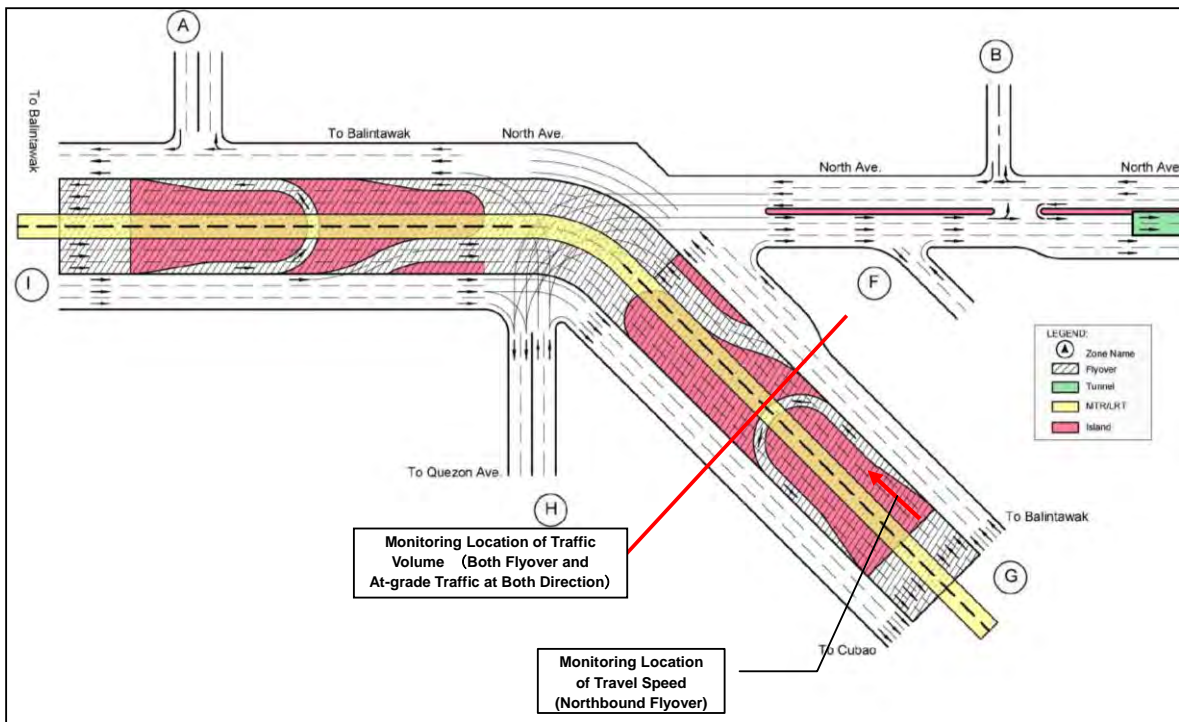

Source: JICA Study Team

**Figure 6.4-2 Monitoring Location for Traffic Volume Count and Travel Speed (EDSA/North Ave./West Ave. Intersection: Along EDSA – Cubao Side)**



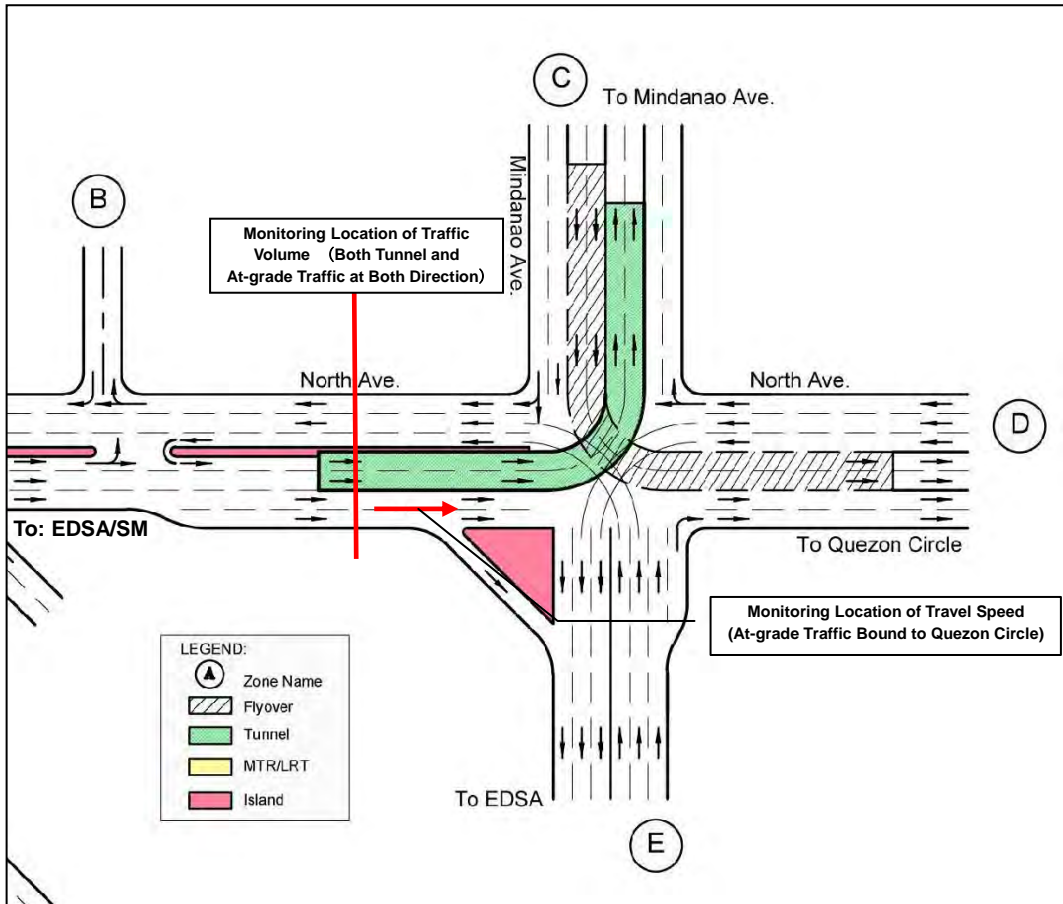

Source: JICA Study Team

**Figure 6.4-3 Monitoring Location for Traffic Volume Count and Travel Speed (North Ave. /Mindanao Ave. Intersection: Along North Avenue – EDSA/SM Side)**

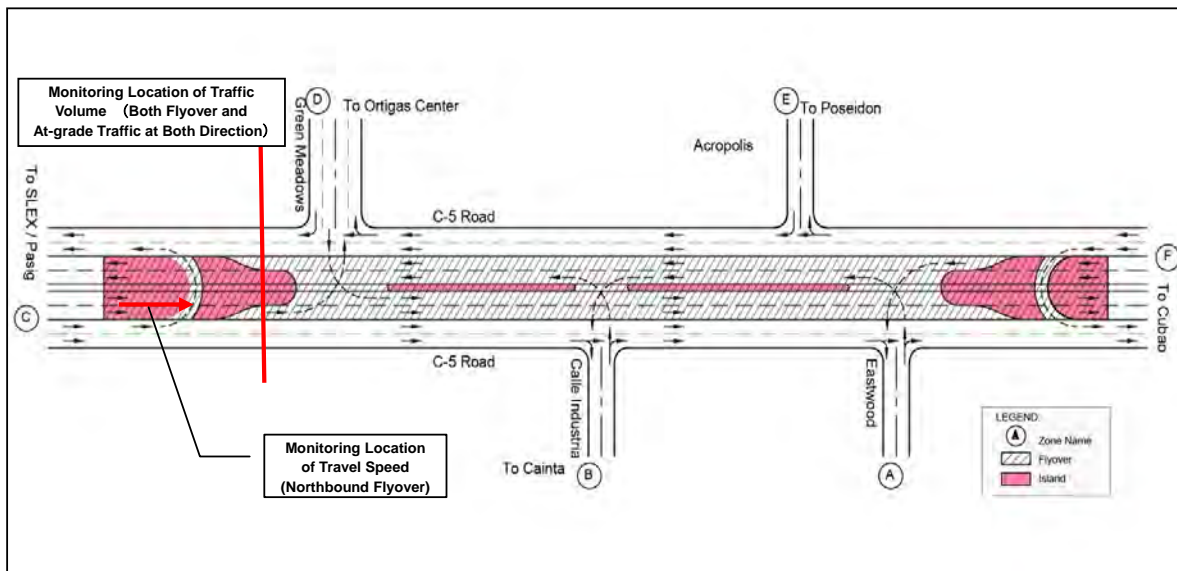

Source: JICA Study Team

**Figure 6.4-4 Monitoring Location for Traffic Volume Count and Travel Speed (C-5/Green Meadows/Acropolis/Galle Industria – Pasig City Side)**

## **6.5 SURVEY ON BENEFIT FOR JAPANESE COMPANIES IN THE PHILIPPINES**

### **6.5.1 Purpose of the Survey**

The purpose of the survey is to verify positive impacts and benefits brought about by the project implementation on Japanese companies that are operating in Metro Manila and adjacent provinces. Expected benefits are mostly reduction of transportation cost for delivery of goods and services passing the project interchanges and adjacent roads within influenced area.

### **6.5.2 Survey Method**

The survey was conducted mainly through interview to the selected Japanese firms that may use project interchanges for their business. Among 600 Japanese firms operating in Metro Manila area and adjacent provinces, 8 to 10 Japanese representative firms, that have long time business operation in the Philippines covering wide areas of Metro Manila with fairly large business transactions, were selected for interview to identify impacts and benefits on their business with the implementation of the project.

The following items were surveyed;

- 1) Current status of transportation system of the firm and potential issues and problems currently facing in the field of transportation.
- 2) Expected improvements on access between port/factory and clients and vice versa brought about by implementation of the Project.
- 3) Expected reduction of transport related costs owing to implementation of the Project.
- 4) Expected change in distribution pattern and business perspectives due to implementation of the project, if any.

### **6.5.3 Companies Interviewed**

The eight (8) representative firms shown in **Table 6.5-1** are identified for interview.

### **6.5.4 Result of Survey**

The followings are major findings.

#### **(1) Firm that Frequently Use Project Interchanges**

Expert oriented firms are not frequent user of project intersections. These firms are find their business centers free from traffic congestion, therefore they are avoiding travel in Metro Manila. On the other hand, firms handle products for domestic consumption necessarily use project intersections since Metro Manila is the biggest market in the country and they have to transport their products to consumers in Manila through project intersections.

**Table 6.5-1 Japanese Affiliated Firms Selected for Interview Survey**

Name of Firm	Location of Office/Factory	Main Field of Business
1. Toyota Motors Philippines Corporation.	<b>Head Office:</b> Ayala Ave., Makati City, MM <b>Factory:</b> Sta Rosa City, Laguna	Passenger car assembly and sales
2. EPSON Precision Philippines Inc.	<b>Head Office, Factory:</b> Lima Technology Center, Lipa City, Batangas	Assembly of office equipment (mainly printer)
3. Itochu Corporation Manila Branch	<b>Head Office:</b> Ayala Ave., Makati City, MM <b>Factory:</b> Batangas, Pandacan in Manila City, Pampanga	LP gas retailing, Convenient store operation, Bio-ethanol production.
4. Ajinomoto Philippines Corporation	<b>Head Office:</b> Makati City, MM <b>Factory:</b> Guiginto in Bulacan	Food ingredients manufacturing
5. Mitsui & Co. (Asia Pacific) PTE. LTD. Manila Branch	<b>Head Office:</b> Ayala Ave., Makati City, MM	General trading
6. Nippon Express Philippines Corporation	<b>Head Office:</b> Pascor Drive, Paranaque City <b>Warehouse:</b> Calamba in Languna	Freight transport
7. Suzuki Philippines, Incorporated	<b>Head Office, Factory:</b> Danny Floro St., Bagong Ilog, Pasig City, MM	Motorcycle assembly and sales, Passenger car sales
8. Honda Philippines Inc.	<b>Head Office, Factory:</b> First Philippine Industrial Park, Tanauan City, Batangas	Motorcycle assembly and sales, Generator sales

Source: JICA Study Team

## (2) Commodity Flow between North and South

The most commodity flow has origin and/or destination from/to Metro Manila, few commodities are directly transported between north area and south area. However, some firms who were interviewed mentioned that electrical and mechanical parts manufactured in the south are transported to factories in the north for assembling via C-3, C-4 (EDSA) and C-5. There is a tendency that assembling factories are located in the north and parts manufacturing factories are located in the south. Transporting parts from south to the north is becoming bigger every year. Mitigation of traffic congestion in Metro Manila will help commodity flow between north and south.

## (3) Poor Access between Expressways and Manila Seaport and Airport

Many Japanese firms raise their concern about poor access to expressways from Manila Seaport and Airport. Cargos arrive at the seaport and airport has to be transported to their factories through South Luzon and North Luzon expressways via heavily congested city roads. Travel along congested city roads hampers timely and efficient transport of imported materials to the respective factories. Furthermore, transport of goods between factories in the north and south is also hampered due to absence of city expressways that connects south and north expressways. Improvement of Major circumferential roads including EDSA to the high standard urban road and/or construction of new urban expressway is expected to promote commodity flow between north and south.

#### (4) Restricted Truck Operation

In addition to heavily congested city roads to the expressways, the law enforcement widely known as “Truck Ban” that restricts travel of trucks along designated roads during designated time adds another drawback to transport activities of Japanese firms.

Some other findings are summarized in **Table 6.5-2**.

**Table 6.5-2 Summary of Findings from Interviews to Japanese Firms**

<p><b>1. Expected Impacts of the Project</b></p> <p>1) If the project will lead to the lift of truck ban, the firm will be greatly benefited (TOYOTA)</p> <p>2) Very favorable impacts on delivery of LP gas (ITOCHU)</p> <p>3) Favorable impacts on delivery of products to consumers (AJINOMOTO, SUZUKI and HONDA)</p> <p>4) Favorable impacts on delivery of imported good to local manufacturers (MITSUI)</p>
<p><b>2. Expected Change in Business Opportunities by the Project</b></p> <p>1) Deduction of transport cost will increase companies profit and more aggressive business plant can be drawn. (ITOCHU, AJONOMOTO, MITSUI , NITTSU, SUZUKI and HONDA)</p>
<p><b>3. Proposed Improvements on Transport System in Metro Manila</b></p> <p>1) Improvement of access road to Manila Port and Expressways (All firms)</p> <p>2) Renovation of NAIA Terminal -1 (TOYOTA, EPSON)</p> <p>3) Construction outer Circumferential Road to bypass Metro Manila (AJINOMOTO, SUZUKI and HONDA)</p> <p>4) Capacity expansion of Manila Seaport (MITSUI, NITTSU)</p> <p>5) Comprehensive traffic management plan (NITTSU)</p>

Source: JICA Study Team

#### 6.5.5 Conclusion

Most firms that engage in delivery of goods and services in Metro Manila express favorable opinion on interchange construction as quick impact project, but they also desire fundamental solution to the Metro Manila traffic by introducing modal sift from vehicular transport to rail transport for passenger movements and introduction of city expressways including construction elevated expressways along EDSA and city expressway connecting North and South Expressways for cargo movements.

## CHAPTER 7

### STUDY OF ENVIRONMENTAL AND SOCIAL CONSIDERATIONS

#### 7.1 ENVIRONMENTAL IMPACT ASSESSMENT STUDY

- ✓ EIA procedure and EIA related Laws and Regulations in the Philippines: The Philippine Environmental Impact Statement System (PEISS) has been established by the Presidential Decree No. 1586 (1978), and implemented by the Department of Environment and Natural Resources (DENR) Administrative Order No. 30 Series of 2003 (DAO 03-30) and its Revised Procedural Manual (2007). The review and supervision of PEISS are conducted by the Environmental Management Bureau (EMB) of the DENR.
- ✓ Analysis of Alternatives: Alternative schemes including a zero option (without-the-project) case for each interchange project were comparatively evaluated from the viewpoints of environmental and social considerations. The recommended schemes have relatively less impacts on natural environment and human health, as well as no involuntary resettlement.
- ✓ Scoping: In accordance with the “JICA Guidelines for Environmental and Social Considerations (2002 April)” (hereafter referred to as JICA Guidelines), scoping was conducted with the analysis of alternatives. The results of scoping show that there are no significant adverse impacts on natural environment and socio-economic conditions. Items which are expected to have some negative impacts are listed in Table 7.1

**Table 7.1-1 Results of Scoping - Adverse Environmental Impacts Land Acquisition**

Items	Construction Phase	Operation Phase
Social Environment	Land Acquisition (no involuntary resettlement), Local economy such as employment and livelihood, Existing social infrastructures and services, Misdistribution of benefit and damage, Water Usage, Sanitation, Risk of Infectious diseases such as HIV/AIDS	None
Natural Environment	Land slide (depressed), Trees, Landscape	Landscape
Pollution Control	Air Pollution, Water Pollution, Soil Contamination, Waste, Noise and Vibration, Accidents	Air Pollution, Noise and Vibration

Source: JICA Study Team

- ✓ Prediction and Assessment: Noise and air pollutants (TSP, SO<sub>2</sub>, NO<sub>2</sub>) emitted from vehicles are predicted based on the projected traffic in 2018. The results of prediction show that:
  - Noise level: Due to the increase of traffic volume, the noise levels will be about 79dB(A) during the day (6.00-22.00) and 75-78dB(A) in the night (22.00-6.00), which are almost the same as the present noise levels . The predicted noise levels at all four

interchanges may exceed the maximum permissible levels (for commercial area) by 10dB(A) during the day and by 20dB(A) in the night.

- Air Pollutants: Because of the increase of average travel speeds and the decrease of vehicle hours, TSP and NO<sub>2</sub> emissions of the with-project-case will reduce by approximately 10 - 20% compared with the zero option case. The emissions of SO<sub>2</sub> will increase by the same amount for both with- and without-project cases. Assuming all other factors being equal to the present conditions, air pollutant concentrations might not exceed the maximum allowable limits of 24 hours average of the Philippine Clean Air Act of 1999 because the present concentrations are well below the limits.
- CO<sub>2</sub> emission: Because of the increase of average travel speeds and the decrease of vehicle hours, the with-project-case will reduce CO<sub>2</sub> emissions by approximately 10-20% compared with the zero option case.
- ✓ Mitigation Measures: Technically feasible mitigation measures during the construction and operation phases are drawn up and proposed for four interchange projects.
  - During construction, pollution control measures should be implemented in order to prevent any pollutions from operation of heavy vehicles/machines and civil/construction works.
  - The Traffic Management Plans should be drawn up to mitigate traffic congestion during construction, and also abate the traffic accidents in cooperation with Barangay communities.
  - After opening the interchange, noise levels are regularly monitored. Installation of noise barriers should be considered where the noise levels significantly exceed the permissible levels in residential zones.
  - In addition to restoring trees during construction, trees should be planted in central reserves and sidewalks as much as possible. Vegetation may improve the local aesthetic views, and also mitigate the noise and air pollutants emitted from vehicles.
- ✓ Monitoring: In order to ensure the effectiveness of mitigation measures and monitor the unexpected impacts, the Environmental Monitoring Plans for the construction and operation phases are drawn up. After opening the interchanges, replanted trees, ambient air quality, and noise and vibration should be regularly monitored.
- ✓ According to the criteria of PEISS, DPWH will submit the Initial Environmental Examination (IEE) reports to DENR EMB for each interchange project in order to apply the Environmental Compliance Certificate (ECC).

## 7.2 LAND ACQUISITION AND RESETTLEMENT ACTION PLAN (RAP)

- ✓ In comparison to JICA Guidelines and World Bank Operational Policies, there are no variances in terms of the objectives of the JICA Guidelines/WB OP 4.01 and the Philippine laws/regulations and DPWH policy on land acquisition and RAP. The Project Policy on compensation is based on the full replacement cost.
- ✓ The results of the census survey and inventory (assets and land) survey are shown in **Table 7.2-1**. At the C-3/E. Rodriguez Interchange, 94 informal settlers had been already relocated to the outside of the ROW by the MMDA's METRO GWAPO Program.
- ✓ The JICA Study Team supported DPWH to prepare the Abbreviated Resettlement Action Plan (ARPA) in line with DPWH's Land Acquisition, Resettlement, Rehabilitation and Indigenous Peoples' Policy (LARRIPP) and JICA Guidelines.
- ✓ The compensation entitlements for each category of PAPs, resettlement implementation committee for grievance redress, internal and external monitoring agents are drawn up in the ARAPs.

**Table 7.2-1 Land Acquisition, Involuntary Resettlement and Affected Structure for MMICP**

Interchange	Land Acquisition	Resettlement	Affected Structure
C-3/E. Rodriguez	None	None	None
EDSA/Roosevelt/Congressional	None	None	5 stalls (marginal* <sup>1</sup> )
EDSA/North/West/Mindanao	Additional ROW for sump pit (100 sq.m)	None	25 stalls (marginal* <sup>1</sup> )
C-5/Green Meadows/Acropolis/ Calle Industria	None	None	None

Source: JICA Study Team

Note : the impact is only partial and the remaining portion of the property or asset is still viable for continued use.

## 7.3 SUPPORT DPWH TO HOLD PUBLIC CONSULTATION MEETINGS

- ✓ In accordance with JICA Guidelines, DPWH assisted with JICA Study Team hold Public Consultation Meetings for Barangays communities and stakeholders at four interchange project sites.
- ✓ The communities and stakeholders favored the interchange projects to ease the present traffic congestion. There were the comments on the implementation of the Traffic Management Plan during construction, noise mitigation measures for the flyovers and restoration of cutting trees due construction. DPWH will draw up the proper countermeasures in planning of the interchange projects against these issues raised by stakeholders.

## CHAPTER 8

### C-3 MISSING LINK

#### 8.1 BACKGROUND TO THE STUDY ON THE C-3 MISSING LINK

The southern segment (hereafter referred to as the C-3 Missing Link) has not yet been implemented. The circumferential road network serving south-central Metro Manila is, therefore, still not functioning effectively resulting in heavily congested traffic conditions on EDSA. Construction of the C-3 missing link, together with the construction of the flyovers proposed under this preparatory survey, is expected to significantly contribute to the decongestion of heavy traffic along the circumferential roads. The study involved review of the C-3 missing link construction report and also study of influence to the proposed flyovers by the captioned project.

#### 8.2 PROJECT SETTING

##### 8.2.1 Administration, Population and Land Use

The proposed alternative alignments run through four (4) cities in the Metropolitan Manila, namely San Juan City, Mandaluyong City, Manila City and Makati City. All affected cities are primarily highly urbanized with scattered factory/industrial developments.

Informal settlements are located beside SM City Sta. Mesa near C-3 Road side.

##### 8.2.2 Topography and Geology of Project Area

The topography of Metro Manila can be classified into three zones, namely; (1) the Coastal Lowland along Manila Bay, (2) the Central Plateau and (3) Marikina Plain. The surface geology of the Central Plateau consists of deposits of the Guadeloupe Tuff formation. On the other hand, the Coastal Lowland and the Marikina Plain mainly consist of alluvium deposits.

##### 8.2.3 River Systems

###### (1) Pasig River

The 27km of Pasig River is technically a tidal estuary, as the flow direction depends upon the water-level difference between Manila Bay and Laguna de Bay. The average width of Pasig River is 91m and average depth is 4m with the deepest sections being 6m. Flow volume can be as low as 12cum/sec in the dry seasons whereas during the rainy season flow can increase to 275 cum/sec.

The lowest bridge, with a vertical clearance of only 3.5m above high water level, is the Ayala Bridge that can only be navigated by larger vessels during periods of low tide.

###### (2) San Juan River

The channel length of San Juan River is 11.0km and the width of the river in the project area is typically 40m-50m. The river is flood prone over most of its length with wide areas of



floodwater breakout, including those within the project area.

The San Juan River is not navigable and is outside of the mandate of the Philippine Coast Guard.

### **8.3 ALTERNATIVE ALIGNMENTS AND DPWH COMPARATIVE STUDY**

#### **8.3.1 Alternative Alignments**

The six (6) alternative alignments for the C-3 Missing Link were presented to the Secretary of DPWH in July 2011, together with a comparative study prepared by its URPO. These alignments are presented in **Figure 8.3-1**.

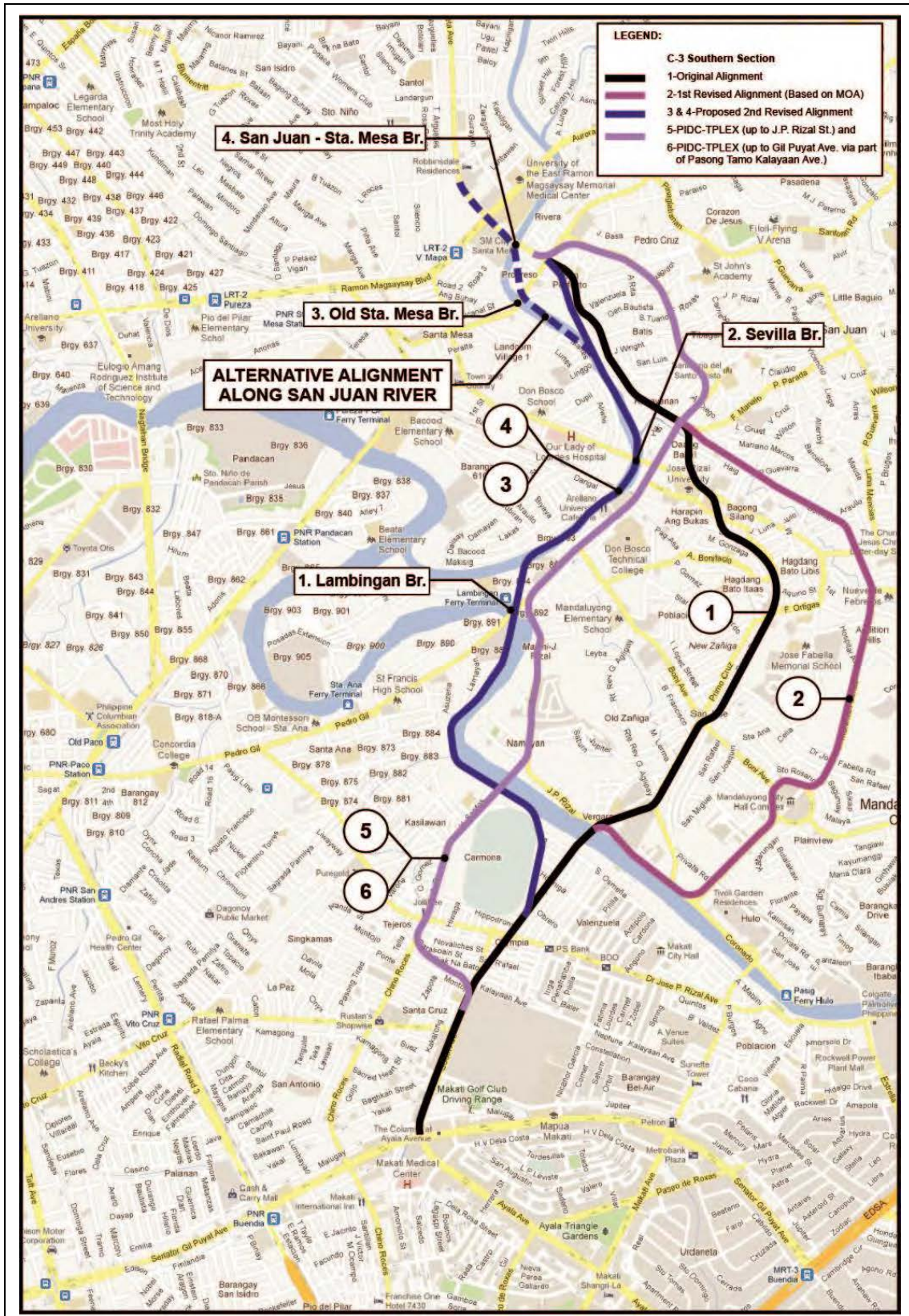

Source : URPO

Figure 8.3-1 Alternative Alignments – DPWH Study

### **8.3.2 DPWH Comparative Study**

6 alternatives were presented by URPO-DPWH considering following items such as length of each alternatives, number of lane, structural type, cost of RROW, construction cost and total cost.

The report also presented advantages and disadvantages for all alternatives but there was no mention which alternative was superior or even did not make ranking among the alternatives.

### **8.3.3 Review of DPWH Comparative Study**

The Study Team established the following evaluation criteria for the review of the DPWH alignment study. 1) Proposed Scope of Work 2) Construction Issue 3) R.O.W. Acquisition 4) Resettlement Issue 5) Environmental Issue 6) Navigation Issue in Pasig River and 7) Construction Cost.

Following conditions were confirmed:

- Number of lanes is 6-lanes under the original plan and the other five alternatives were only 4-lanes.
- Adoption of viaduct section under the original plan is for limited section only while the other five alternatives were to adopt viaduct into longer sections.
- Regarding double deck type viaduct, under the original plan and alternatives 5 and 6, this was not mentioned, while alternative 2 discussed the potential of a double deck type viaduct. On the other hand, alternatives 3 and 4 were planned as single deck type viaduct.
- Regarding RROW, costs of RROW were presented but breakdown and also any descriptions of affected buildings, houses and number of people were not provided.
- Regarding environmental issues, some reference were-made on environmental issues such as scouring and obstructions in the river.
- Estimated costs for each of the alternatives had no detailed cost breakdown.

## **8.4 UPDATED STUDY**

### **8.4.1 Geometric Design Standards**

The proposed geometric design standards for the C-3 Missing Link are adopted from DPWH Standard Design Criteria.

### **8.4.2 Typical Sections**

The number of lanes assumed for the alternative alignments is the same as the existing C-3 Northern Segment, which is a 6 lane divided road.

Proposed viaduct structure should take into consideration certain distances from existing structures, noise and fire, which is regulated under the Water Code of the Philippines.

A road bridge over inland waterways must have a minimum vertical clearance of 3.75m from the highest water level while San Juan River is not navigable.

Based on above conditions, the Study Team prepared five (5) types of typical cross sections, namely: 1) at grade section, 2) viaduct on ground, 3) double deck viaduct on ground, 4) along Pasig River and 5) along San Juan River.

### 8.4.3 Scope of Work of Each Alignment

The scope of work of each alignment is presented in Table as follows:

**Table 8.4-1 Scope of Work of the Alternative Alignments, C-3 Missing Link**

	At Grade	Elevated Single Deck	Elevated Double Deck	Total	R.O.W. Acquisition
Alternative-1	1.05km	0.80km	3.95km	5.8km	102,000m <sup>2</sup>
Alternative-2	1.05km	1.60km	4.65km	7.3km	105,000m <sup>2</sup>
Alternative-3	0.0km	4.55km	1.75km	6.3km	35,000m <sup>2</sup>
Alternative-4	0.0km	4.55km	1.75km	6.3km	92,000m <sup>2</sup>
Alternative-5	1.55km	0.15km	3.40km	5.1km	74,000m <sup>2</sup>
Alternative-6	1.15km	0.15km	5.10km	6.4km	77,000m <sup>2</sup>

Source: JICA Study Team

#### (1) Viaduct Configuration

Single level viaduct structures are proposed as a preferred configuration. However, where available ROW is limited, double deck viaducts have been proposed for consideration.

Long span bridges, in the order of 50m to 100m or so, will be necessary to cross the Pasig River, and the San Juan River.

#### (2) Interconnectivity with Local Roads

The interconnectivity of the proposed alternative alignments with local roads is a key aspect in promoting the functionality of each route.

2- ramps were planned to be provided for each of the alternatives, namely Boni. Ave. and New Panaderos on the south side and Shaw Blvd. on the north side.

#### (3) Navigation Issues in Pasig River

There are typically between 150 to 200 vessel movements along the river every day.

The section of Pasig River just upstream of Lambingan Bridge is already posing navigational problems for the larger vessels plying the river. At this location, the river bends 90 degrees to the right and narrows down from 100m to less than 60m. Any obstructions in the river reducing the navigable width will further exacerbate the already difficult situation.

#### (4) San Juan Pasig River Issues

San Juan River is not navigable and therefore not subject to consideration of vessel navigation and ship collision forces.

San Juan River will have to address hydraulic capacity issues since areas along the river are already flood prone.

#### **8.4.4 Project Affected Buildings and Project Affected People**

Assessment on the numbers of affected buildings and building landmarks have been made from open source satellite images.

The numbers of Project Affected People (PAPs) have been estimated by assuming that the typical average number of persons per household is approximately five (5) based on the data of 2007 Census of Population.

#### **8.4.5 Environmental Issues**

##### **(1) Roadside air pollution**

Among the alternatives, considering that the length of the routes passing through the residential area of Alignments 1 and 2 are longer than other alternatives, the impacts of emission gases will be more significant than other alignments.

##### **(2) Roadside noise impact**

Since Alignments 1 and 2 are established in the populated residential area, noise impact will be the most significant among all the alternatives while for Alignments 3 and 4, which are established along the rivers or on the river banks, noise impact on roadside residences will be less significant than that of the other alternative alignments.

##### **(3) Sunlight easement (shadow control)**

For Alternatives 3 and 4, the elevated viaducts are constructed along the river thus areas in shadow will be smaller than those of other alternative alignments.

##### **(4) Water quality deterioration**

In Alignment 3, piers will be constructed on the riverbeds in Pasig River and San Juan River. Installation of piers may deteriorate river water quality during the construction and also during its operation.

#### **8.4.6 Rough Cost Estimate**

Estimated construction cost and cost of R.R.O.W. acquisition were calculated based on similar completed and on-going project data. Estimated cost is shown as follows:

**Table 8.4-2 Cost Estimate**

Alignment	Original Alignment	1 <sup>ST</sup> Revised Alignment	2 <sup>ND</sup> Revised Alignment a1 (in River)	2 <sup>ND</sup> Revised Alignment a2 (on River Bank)	PIDC-TPLEX Alignment b1	PIDC-TPLEX Alignment b2
	(1)	(2)	(3)	(4)	(5)	(6)
<b>Construction Cost</b>	12,000	14,700	16,400	14,600	9,600	13,900
<b>ROW Acquisition and Land Improvement Cost</b>	5,600	5,700	2,100	4,700	4,100	4,400
<b>Total Cost</b>	17,600	20,400	18,500	19,300	13,700	18,300

Unit = Millions of Pesos

Source : JICA Study Team

#### 8.4.7 Comparative Study

The comparative study of the six potential alignments for the C-3 Missing Link is presented in **Table 8.4-3**.

Table 8.4-3 Comparative Study of the Alternative Alignment, C-3 Missing Link

Ref	Description	Scope and Cost	Construction Aspects	Road Network Aspects	Environmental Impact & Pasig River Navigation	ROW Acquisition (excluding ramps)	Project Affected People	Comment
1	Original Alignment (6 Lane, 5.8 km.)	Relatively narrow available width along South Ave. (Makati), and Shaw Boulevard (Mandaluyong) to N. Domingo (San Juan), with substantial commercial and institutional developments each side require the use of a double deck viaduct at these locations . COST: 17,600MP	Adequate traffic management during construction will be crucial.	Connects to both Boni Avenue and Shaw Boulevard. Double deck configuration at Shaw and N. Domingo will require longer access ramps and greater ROW acquisition. The double deck structure along South Ave. will require ramps onto Gil Puyat and Ayala Avenue.	Since the route is established in the populated residential area, the impacts of emission gases, noise and sunlight shading will be the most significant among the alternatives and must be mitigated. Number of impacts: 8	Very substantial ROW acquisition (102,000 sqm). Requires wholesale demolition at: Olympia Ville, Mandaluyong Cemetery, Core Oil Gas Station, Barangay Hall Bagong Silang, and residential blocks from Valenzuela to N. Domingo. Encroachment into Manila South Cemetery is avoided with double deck viaduct along South Ave.	Maximum estimated number of PAPs at 4,430.	Large area of ROW acquisition and largest number of PAPs makes this one of the least favored routes.
2	1 <sup>ST</sup> Revised Alignment (6 Lane, 7.3 km.)	Relatively narrow available width along South Ave. (Makati), and the Maytunas Creek alignment in San Juan requires the use of a double deck viaduct to limit ROW acquisition. COST: 20,400MP	Adequate traffic management during construction will be crucial.	Connects to both Boni Avenue and Shaw Boulevard. Double deck configuration at Shaw and N. Domingo will require longer access ramps and greater ROW acquisition. The double deck structure along South Ave. will require ramps onto Gil Puyat and Ayala Avenue.	Since the route is established in the populated residential area, the impacts of emission gases, noise and sunlight shading will be the most significant among the alternatives and must be abated. Number of impacts: 8	Greatest ROW acquisition (105,000 sqm). Requires wholesale demolition at: Olympia Ville, residential blocks at corner of Coronado-San Francisco, along Maytunas Creek (partial), and residential blocks from Valenzuela to N. Domingo. Encroaching into Manila South Cemetery is avoided with double deck viaduct along South Ave.	Second largest estimated number of PAPs at 3,925.	Largest area of ROW acquisition and very large number of PAPs makes this one of the least favored routes.
3	2 <sup>ND</sup> Revised Alignment a1 (6 Lane, 6.3 km.)	Relatively narrow available width along South Ave. (Makati) requires the use of a double deck viaduct at this location. Single deck viaduct can be used elsewhere for elevated sections. Third level >100m long span required over Lambingan Bridge. COST: 18,500MP	Access along both waterways will be required for construction. Barges could be used both to deliver materials and as a platform for construction equipment along Pasig River. Cranes may be necessary along San Juan River given that the river is not navigable. Water craft management, using a one-direction at a time ship control system, will be required in Pasig River.	Connects to both New Panaderos and Shaw Boulevard. Single level deck will facilitate simpler access ramp layouts. The double deck structure along South Ave. will require ramps onto Gil Puyat and Ayala Avenue.	Piers will be constructed on the riverbeds in Pasig River and San Juan River. Installation of piers and untreated storm runoff may deteriorate river water quality. Ease of navigation along Pasig River will be severely impacted especially where the river narrows and at the point where the rivers bends 90 degrees on the approach to Lambingan. Number of impacts: 3	Least ROW acquisition (35,000 sqm) given that most of alignment is in Pasig and San Juan River. There is a requirement to partially demolish Olympia Ville, between Kalayaan Avenue and J.P. Rizal. Encroachment into Manila South Cemetery is avoided with double deck viaduct along South Ave.	Smallest estimated number of PAPs at 550.	Most favored in terms of limiting area of ROW acquisition and number of PAPs. However construction along sections of Pasig River may not be possible given the existing critical navigation problems.
4	2 <sup>ND</sup> Revised Alignment a2 (6 Lane, 6.3 km.)	Relatively narrow available width along South Ave. (Makati) requires the use of a double deck viaduct at this location. Single deck viaduct can be used elsewhere for elevated sections. Third level >100m long span required over Lambingan Bridge. Local road access along the river bank at grade can be provided within the width of ROW acquisition. COST: 19,300MP	Construction access along the river banks can be made after the easement has been cleared. No construction activities are required in the river waterways.	Connects to both New Panaderos and Shaw Boulevard. Single level deck will facilitate simpler access ramp layouts. The double deck structure along South Ave. will require ramps onto Gil Puyat and Ayala Avenue.	Since the route is established in the populated residential area, noise abatement measures will be needed. Number of impacts: 4	Still substantial ROW acquisition (92,000 sqm) given the need to acquire ROW along the river banks of Pasig and San Juan River. Substantial demolition of industrial and residential properties. There is a requirement to partially demolish Olympia Ville, between Kalayaan Avenue and J.P. Rizal. Encroachment into Manila South Cemetery is avoided with double deck viaduct along South Ave.	Second smallest estimated number of PAPs at 950.	Reasonably favored in terms of limiting number of PAPs. No adverse impacts on river waterway or navigation. However construction along the banks will still require substantial ROW acquisition.
5	PIDC-TPLEX Alignment b1 (6 Lane, 5.1 km.)	The narrow available width along New Panaderos (Mandaluyong) and Blumentritt (San Juan) has dictated the use of a double deck viaduct to limit ROW acquisition. COST: 13,700MP	Adequate traffic management during construction will be crucial.	Connects to both New Panaderos and Shaw Boulevard. Double deck configuration at both locations will require longer access ramps and greater ROW acquisition.	Since the route is established in the commercial and residential area, the impacts of emission gases, noise and sunlight shading should be mitigated. Number of impacts: 6	Double deck configuration limits ROW acquisition (74,000 sqm). However many properties affected including commercial buildings especially along New Panaderos and F. Blumentritt. Curved alignment cuts the corner at F. Blumentritt requiring wholesale demolition in one section.	Estimated number of PAPs still substantial at 1,765.	Route not favored since it does not extend to Gil Puyat.
6	PIDC-TPLEX Alignment b2 (6 Lane, 6.4 km.)	The narrow available width along South Ave. and Kalayaan (Makati), New Panaderos (Mandaluyong) and Blumentritt (San Juan) has dictated the use of double deck viaducts to limit ROW acquisition. COST: 18,300MP	Adequate traffic management during construction will be crucial.	Connects to both New Panaderos and Shaw Boulevard. Double deck configuration at both locations will require longer access ramps and greater ROW acquisition. The double deck structure along South Ave. will require ramps onto Gil Puyat and Ayala Avenue.	Since the route is established in the commercial and residential area, the impacts of emission gases, noise and sunlight shading should be mitigated. Number of impacts: 6	Double deck configuration limits ROW acquisition (77,000 sqm). Affected properties same as above. In addition ROW acquisition along Kalayaan Avenue will be required. Encroachment into Manila South Cemetery is avoided with double deck viaduct along South Ave.	Estimated number of PAPs still substantial at 2,085.	Route not favored given the need for ROW acquisition along commercial strips, despite double deck construction, and wholesale demolition in Blumentritt to accommodate the curved alignment.

Source : JICA Study Team



#### 8.4.8 Effect on the Project Interchanges due to Construction of the Missing Link

The effect on the Project interchanges due to construction of the Missing Link was analyzed using MMUTIS<sup>6</sup> data.

MMUTIS is the “Metro Manila Urban Transportation Integration Study” undertaken by the JICA in 1998. MMUTIS data is currently the latest available traffic study regarding the whole of Metro Manila area arterial traffic through the MMUTIS Traffic Demand Forecast Model of the transport network that covers the entire Manila Metropolitan Area.

MMUTIS covers the transport network in the metropolitan area and includes the project coverage of the 5 interchanges (C-3/E Rodriguez, EDSA/Roosevelt/Congressional, EDSA/North/West/Mindanao, C-5/Kalayaan, C-5/Green Meadows/Acropolis/Calle Industria) and the C-3 Missing Link is therefore deemed suitable for the effect analysis. Effect analysis was done for the C-3 Missing Link assuming the opening year at 2018.

**Figure 8.4-1** shows the traffic volume increase/decrease percentage (with Project/without Project) for the case of C-3 Missing Link construction in 2018 as its opening year.

Due to C-3's connection to other roads, much traffic running on other ring roads will divert to C-3 with the Missing Link in place. Therefore, traffic volumes of other ring roads will tend to decrease.

---

<sup>6</sup> MMUTIS - “Metro Manila Urban Transportation Integration Study” done by JICA in 1998.



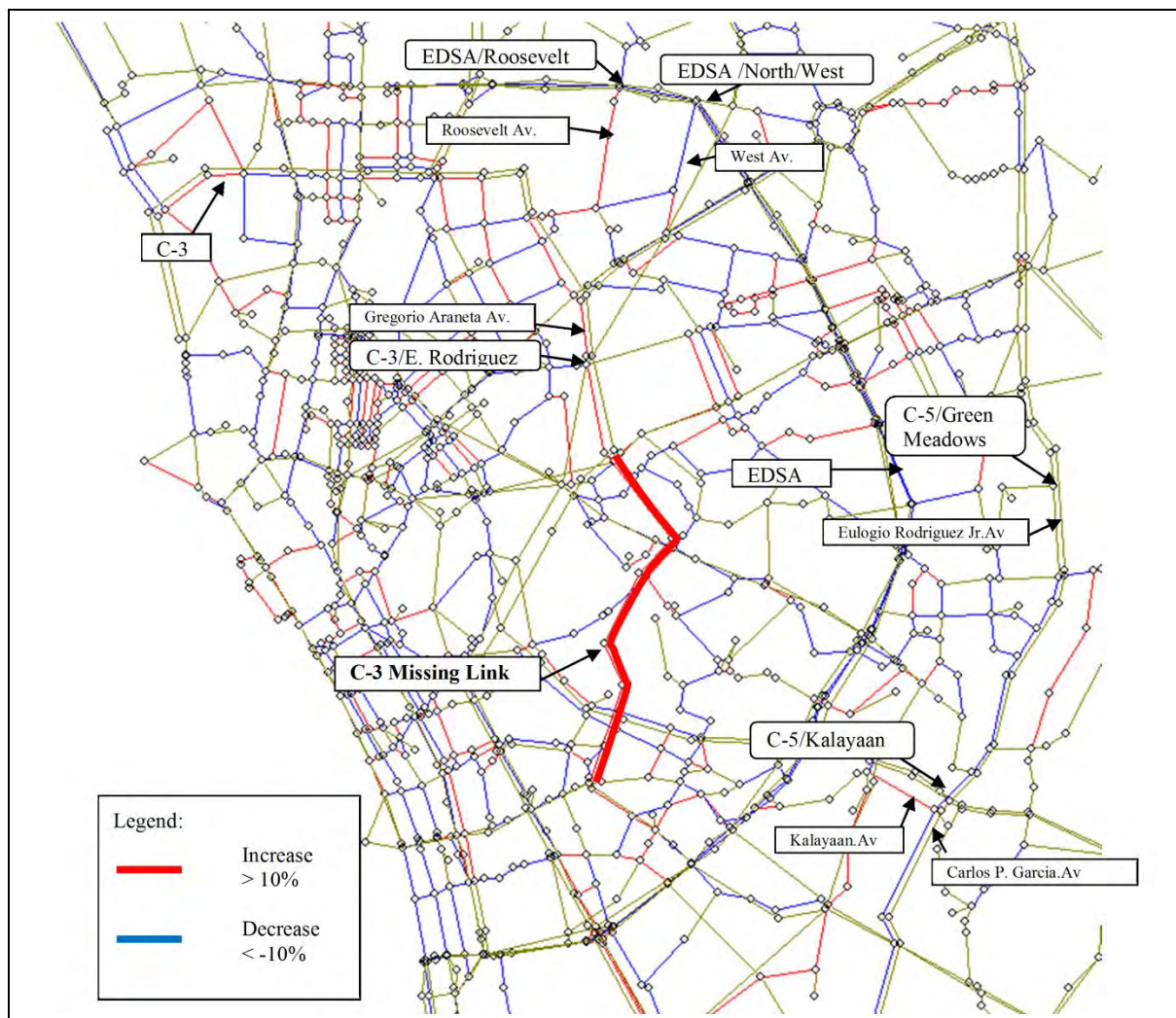

Source: JICA Study Team

**Figure 8.4-1 Effect on Traffic Volume for the Project Interchanges due to Construction of the C-3 Missing Link**

The effects on each of the intersections are as follows:

**(1) C-3/E. Rodriguez**

The south road connects to the Missing Link; therefore, the effect is substantial. Traffic between the north and south (Gregorio Araneta Avenue) will increase by 26-56%.

**(2) EDSA/Roosevelt/Congressional**

It is located in the north area far from the Missing Link. The traffic on Roosevelt Avenue connecting to the Missing Link will increase by 46%, but the effects on traffic volume for other roads connecting to the interchange will be minimal.

**(3) EDSA/North/West/Mindanao**

It is located in the north area far from the Missing Link. Traffic on West Avenue will divert to Roosevelt Avenue at EDSA/Roosevelt/Congressional interchange. The traffic volume will be reduced by about 30%. Roosevelt Avenue is closer to C-3 than West Avenue. Effects on traffic

volume for other roads connecting to the interchange will be minimal.

**(4) C-5/Kalayaan**

It is on a ring road (Carlos P. Garcia Avenue) parallel to the Missing Link. Traffic on Kalayaan Ave. will increase by about 10%. Traffic on Carlos P. Garcia Ave. will decrease by about 10%.

**(5) C-5/Green Meadows/Acropolis/Calle Industria**

It is on a ring road (Eulogio Rodriguez Jr. Avenue) parallel to the Missing Link but it is far from the Missing Link. The effect on traffic volume will be minimal.

**8.4.9 Recommendations**

Several alternative alignments for the C-3 missing link have been proposed and studied since the early 1970s, but the project has not been pursued due to the huge RROW requirement, the large number of PAPs, the high cost of the project, and the long duration it will take from the study stage until completion of implementation. Further delay in the construction of said missing link will not be acceptable considering its expected impacts on the present traffic situation in Metro Manila.

The most favored alignments are those that follow the Pasig and San Juan Rivers. These alignments are favored given that both of the number of affected buildings and PAP's are minimized and also the environmental impacts of these alignments are the least.

However, both alternatives have drawbacks: the navigation problems in Pasig River; obstruction of waterway area in San Juan River for the scheme occupying the waterways, and, a need for substantial ROW acquisition for the scheme occupying the river banks.

It is recommended that the Study on the C-3 Missing Link should be the subject of a feasibility study. The scope of the feasibility study should be:

- |   |
|---|
| <ol style="list-style-type: none"><li>1. Review and confirm the necessity of the Project</li><li>2. Establish future traffic demand and existing site conditions based on:<ul style="list-style-type: none"><li>• Outline design of alternatives schemes</li><li>• Preliminary design of preferred scheme including cost estimate.</li></ul></li><li>3. Prepare proper construction period and implementation schedule.</li><li>4. Formulate a Feasibility Study Report, including calculation of EIRR in accordance with NEDA protocols and examination of environmental and social considerations.</li><li>5. Prepare a Resettlement Action Plan (RAP)</li><li>6. Identify expected financing scenarios and possibility of using Japanese ODA</li></ol> |
|---|

**8.4.10 Related Proposed Projects in Metro Manila**

In addition to the DPWH proposal for a C-3 Missing Link Project, there are several other proposals, from the private sector and other government agencies, to provide elevated roadways serving a similar function or occupying corridors that may intersect with the C-3 Missing Link Project.

Refer to **Figure 8.4-2** for a location plan of the related proposed projects.

(a) C-3 Expressway (Ayala Corporation)

The C-3 Expressway involves a 16.2 km., 6 lane divided roadway. It will keep the existing segments of C-3 road as public access roads with grade separation improvements at the major proposed intersections along the line (E. Rodriguez, Quezon Avenue, Del Monte, A Bonifacio and 5th Avenue W/Rizal Avenue).

Southern section this proposed project effectively overlaps with the preferred DPWH alignment for the C-3 Missing Link.

(b) NLEX-SLEX Connector (MNTC)

The 13.3 km NLEX-SLEX Connector is a 4 lane divided elevated tolled roadway that starts at Skyway Buendia, and the alignment follows PNR tracks up to Caloocan and terminates at the connection to the NLEX via Segment 10 of the NLEX Phase 2 project at 5th Avenue.

The proposed elevated road will not share any section of the C-3 Missing Link Project corridor.

(c) Metro Manila Skyway Stage 3 (CITRA/PNCC)

The 14.5km Metro Manila Skyway Stage 3 is a 6 lane divided elevated tolled roadway that starts at Skyway Buendia,, turns right on Quirino Avenue, turns left at San Juan Bridge, follows G Araneta Avenue and then right at A Bonifacio. The proposed roadway terminates at Balintawak on EDSA, linking to NLEX.

This proposed elevated road will occupy the same corridor as the C-3 Missing Link at the junction of N. Domingo with G. Araneta.

(d) SKYBRIDGE (MMDA)

The Skybridge will be an 8.3km 6 lane divided elevated roadway following the route of the preferred DPWH alignment, from JP Rizal Avenue, following the route of the Pasig River and San Juan River and terminating at the Quezon Avenue.

This proposed project effectively overlaps with the preferred DPWH alignment for the C-3 Missing Link extending the scope of the project to Quezon Avenue.





Project	Proponent	Length (km)	Legend	Remarks
C-3 Missing Link	DPWH	6.3		6 lanes - ODA
Skybridge	MMDA	8.3		6 lanes - MYDA
Skyway Stage 3	CITRA	14.5		6 lanes - PPP
NLEx-SLEx Connector	MNTC	13.3		4 lanes - BOT
C-3 Expressway	AYALA	16.2		6 lanes – BOT / PPP

Source: JICA Study Team and proponents of the projects

Figure 8.4-2 Related Projects in Metro Manila

## CHAPTER 9

### THE CONCEPTUAL STUDY FOR THE TRAFFIC CAPACITY EXPANSION ALONG EDSA

#### 9.1 BACKGROUND OF THE PROJECT

The 24 km length of EDSA is the main circumferential road of Metro Manila and more than 200,000 vehicles per section on average passes every day. Notwithstanding the improvements to EDSA brought by the construction of several interchanges, in addition to the MRT Line-3 and LRT Line-1 North Extension, the limited capacity of EDSA to handle the large daily volumes of traffic from early morning to late evening has resulted in severe congestion and low traffic speeds. Such a situation is severely hampering the socio-economic development of Metro Manila and is an impairment to the environment.

In view of the above critical condition, a Conceptual Study on Traffic Capacity Expansion along EDSA has been proposed.

#### 9.2 OBJECTIVES AND CONCEPT OF CONCEPTUAL STUDY

The main objective of the study of the capacity expansion of EDSA is to determine the availability of space and identify possible problem(s) in the construction of a viaduct/tunnel along EDSA considering the existing structures and also the proposed flyovers.

#### 9.3 CONFIRMATION OF CONSISTENCY BETWEEN THE PROPOSED PROJECT AND PRESENT TRAFFIC PLANS IN THE METRO MANILA

Some existing plans of trunk roads, expressways and railways are related to the proposed study with regards to the share of traffic volume but these should not be affected or disturbed much in the implementation of the proposed project.

#### 9.4 CONFIRMATION OF OPEN SPACES FOR TUNNEL PLAN AND VIADUCT PLAN

The study will confirm in outline the availability of open space to accommodate the support structures of high level viaduct solutions and tunnel solutions at critical locations along EDSA. The basic concept in assessing available space is to develop outline solutions that will minimize occupation of width along EDSA and also minimize ROW acquisition where and if necessary.

#### 9.5 CONFIRMATION OF HINDRANCE STRUCTURES

The following hindrance structures for both directions on EDSA have been identified:

MRT/LRT Station	: 15 stations
Flyover along/across EDSA	: Southbound=13 locations, Northbound=14 locations
Under pass along/across EDSA	: 4 locations
Pedestrian Bridge	: 30 locations



There are shown in **Figure 9.5-1**.

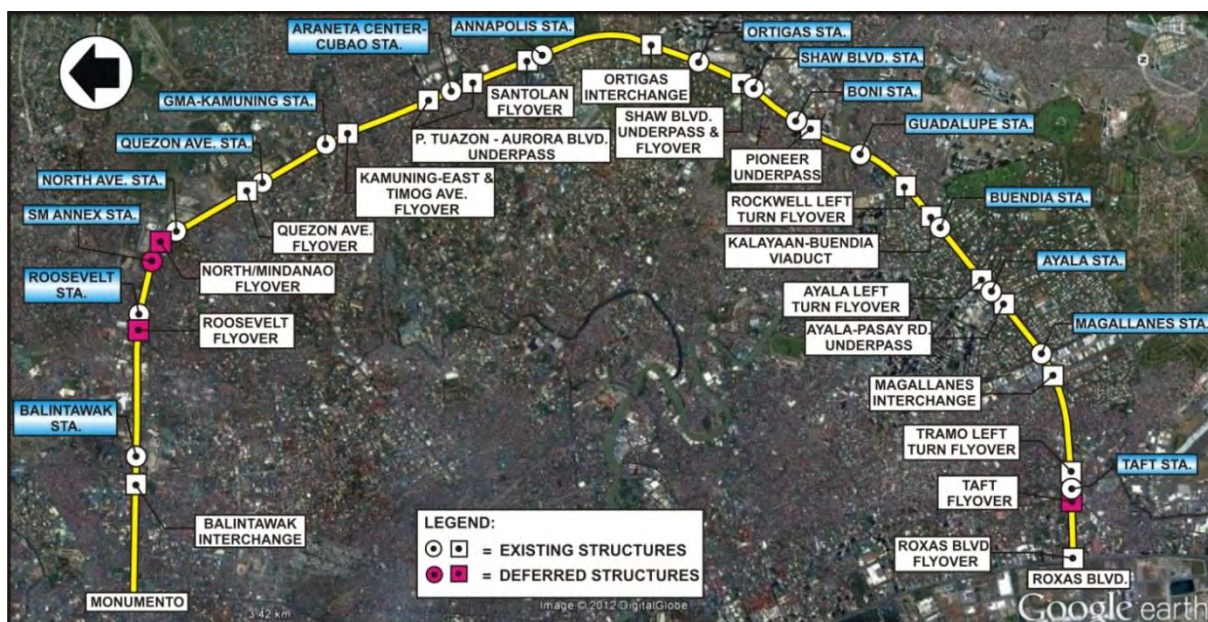

Source: JICA study team

**Figure 9.5-1 Locations of Flyover/Underpass and MRT/LRT STATIONS**

## 9.6 EDSA GENERAL CONDITION

### (1) Topology

EDSA generally has a 50.0m road right of way (RRW). It commonly has ten (10) lanes with five (5) equal lanes per direction divided by a median separator. Within the 3.0 m sidewalks, street lights, various utility posts and other overhead cables are found. Several other utility lines for water, sewerage, etc., are encased in pipes below ground beneath both sidewalk and the road itself. A median separator exists throughout EDSA. Both the MRT-3 and LRT-1 North Extension fully occupies this corridor.

Various commercial buildings (malls, markets, shops, etc.), residential structures (hotels, condominiums, apartments, houses), government and private office buildings are lined up along EDSA and there are two military camps also located along EDSA.

### (2) Traffic Condition

To ease traffic flow on EDSA slow moving cargo trucks have been prohibited on its major sections, between Pasong Tamo in Makati and Balintawak in Quezon City/Caloocan City. This is imposed except on a specific time window which is from 9:00pm to 6:00am daily except Sundays, and Holidays. To further decongest EDSA, a volume reduction scheme has been implemented to reduce daily traffic theoretically by twenty percent (20%) by prohibiting all vehicle types on the basis of its last digit plate number from 7:00am to 7:00pm. On year 2008 the AADT on several segments of EDSA have already reached more than 200,000 vehicles. For a roadway with ten-lane capacity this corresponds to a level of service (LOS) F. With the above conditions

prevailing: EDSA at over capacity, prohibitive cost in acquiring additional RROW, and alternative routes also congested, a capacity expansion scheme via elevated or underground expressway is seriously being considered.

### **(3) Hindrance Structures/Sections**

As described above, improvement of traffic flow along EDSA especially at major intersections necessitated construction of several grade level separation structures.

As earlier discussed, there are numerous MRT-3 and LRT-1 stations on EDSA which straddle over its northbound and southbound lanes. The locations of these grade level separation structures and stations should be considered.

## **9.7 VIADUCT SCHEME**

### **9.7.1 Proposed Viaduct Plan and Profile**

It is proposed that a 23.36km six (6) lane expressway be erected over EDSA to increase its traffic capacity. This concept will require columns and foundations, over the current roadway. This will diminish the number of at-grade lanes per direction from five to four. However after the construction of the elevated viaduct, EDSA will have seven total lanes per direction.

The viaduct layout over the middle lane is preferred as it requires the least impact on existing overhead and underground utilities and the least reconstruction of existing drainage structures. The elevation or height of the viaduct is maintained at second level where possible. It is proposed that the viaduct generally traverse above all pedestrian footbridges with sufficient vertical headroom.

For site conditions requiring long spans and high piers, steel box girders supported by rectangular steel columns are recommended. Although costly these are more effective structurally and faster and easier to construct.

In case of double deck type, viaduct pier supports a three lane upper thoroughfare on top of another three lane thoroughfare for the opposing traffic direction at its lower deck. These steel viaduct piers are shown in **Figure 9.7-1**

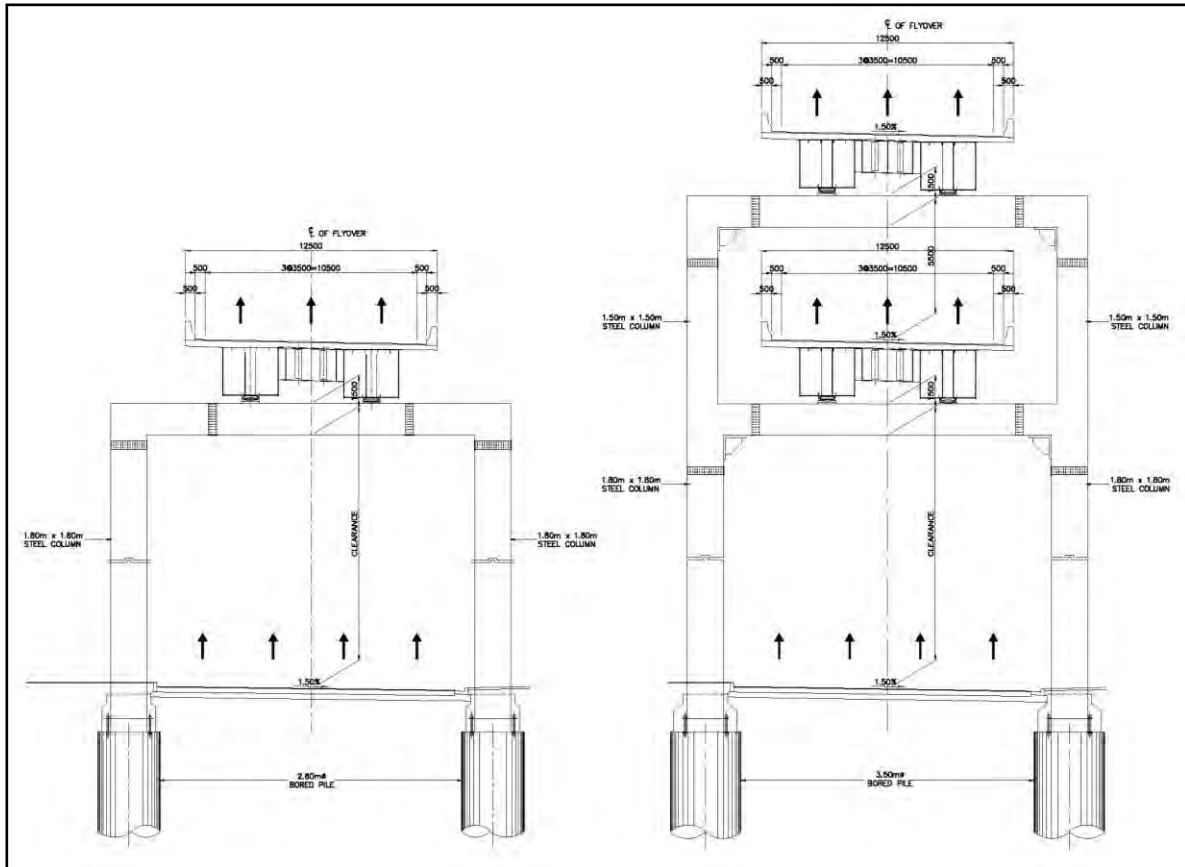

Source: JICA study team

**Figure 9.7-1 Steel Viaduct Piers**

### 9.7.2 Proposed Location of Ramps

The ramps give access to the major central business districts (CBD) of Makati and Ortigas, and the hub of government offices in Quezon City and distance between each ramps are about 5.3km each.

Construction of ramps are absolutely necessary to secure additional RROW either along EDSA or along the selected secondary roads deemed suitable as proposed ramp location. The estimated additional RROW requirement for an elevated viaduct scheme on EDSA is roughly 140,000 sq m.

### 9.7.3 Description of Five High Critical Hindrance Structures/Sections

The stretch of EDSA was examined to identify the five most difficult locations for a viaduct construction. A list ranking first the site assessed with the major hindrance and the most difficult construction is presented below:

- i. Osmeña Highway [Magallanes] Intersection (R3-road crossing EDSA)
- ii. Shaw Blvd. Intersection (R-5-road crossing EDSA)
- iii. Ortigas Ave. Intersection
- iv. Aurora Blvd. [Cubao] Intersection (R-6-road crossing EDSA)
- v. Quezon Ave. Intersection (R-7-road crossing EDSA)



The exact locations of these sites are shown in **Figure 9.7-2**.



Source: JICA study team

**Figure 9.7-2 Location of the Five Most Difficult Construction Site**

#### **(1) Osmeña Highway (Magallanes) Intersection**

The difficulty at this site is the co-existence of several transport facilities (ie., Skyway's Toll Expressway, DPWH's Magallanes Interchange, and DOTC's Philippine National Railway (PNR) train tracks, and MRT-3 light rails). Each entity requires vertical and horizontal clearances to their transport corridor. Thus at this setting, it is more than likely that the viaduct shall have long spans (45m to 60m) and tall piers (24m to 32m) because of the said restrictions. For this viaduct configuration steel structures are recommended.

#### **(2) Shaw Blvd. Intersection**

At this intersection there are multi-level grade separation structures. An underpass road along EDSA and a third level flyover across EDSA along Shaw Blvd above the second level viaduct of the MRT-3. A platform station is also located very near the intersection South of EDSA. The following malls; Rustan's Shangrila, Starmall, and EDSA Central occupy the three corner lots of the intersection.

If the viaduct alignment is confined within EDSA RROW, the necessary viaduct length spanning the covered segment of EDSA is 130m long with pier height at 24m above level ground. To reduce the required span length, the alignment is shifted West of EDSA and a double deck steel viaduct is proposed so that this reduces the superstructure span to 60.0m. But still at this intersection, acquisition of RROW is required.

### **(3) Ortigas Ave. Intersection**

The interchange at Ortigas intersection has the main flyover on the second level of EDSA. The left turn flyovers to Pasig and Mandaluyong cross over at the third level. The MRT-3 viaduct also runs along EDSA at second level above the southbound service lanes and these structures fully obstruct the passage southbound. The only usable corridor is above the northbound two-lane service road adjacent to the EDSA National Shrine.

To fit six lanes over two available at-grade lanes and acquire the least RROW, a double deck viaduct is proposed. For high piers and long spans, steel members are suitable viaduct components because lighter materials are more manageable to handle and easily erected.

### **(4) Aurora Blvd. (Cubao) Intersection**

MRT-3 is along EDSA at second level, whereas LRT-2 is along Aurora Blvd at third level crossing EDSA. Both are above the six lane depressed road along the centerline of EDSA. Therefore, both the northbound and southbound viaducts will have three lanes and are raised almost at fifth level as they cross Aurora Blvd. The recommended steel viaduct will have tall piers with heights near 30m and long spans approximately 50m to 60m.

### **(5) Quezon Ave. Intersection**

On EDSA a three-lane flyover on both northbound and southbound directions concurrently with a four-lane divided underpass, crossing below EDSA along Quezon Avenue, while on the other hand, the MRT-3 trains run on a viaduct between these flyovers. The construction of proposed flyovers leave only two traffic lanes on either direction at the outer service lanes.

Therefore, the proposed viaduct will utilize the available space above the service lanes which will be at third level or 16m above ground. The maximum span will be at approximately 45m to 55m enough to span over Quezon Avenue.

#### **9.7.4 Find Space for Proposed Viaduct**

Result of study of five (5) intersections which identified most difficult locations shows that found spaces for proposed viaduct structures which means that also can be found space for the proposed flyovers due to difficulty of the proposed flyover are equal or lower than five(5) study conducted intersections.

#### **9.7.5 Cost Estimate**

Estimated Cost is as follows:

**Table 9.7-1 Summary of Estimated Project Cost**

ITEM NO.	DESCRIPTION	UNIT	QTY.	COST (MP)	Remarks
<b>A.</b>	<b>Direct Construction Cost</b>			92,592	
A.1	Facilities for the Engineer (1% of A.3 – A-7)	l.s.	1.0	890	
A.2	Other General Requirements (3% of A.3 – A.7)	l.s.	1.0	2,671	
A.3	At-Grade Road Improvement	l.s.	1.0	1,272	
A.4	Bridge and Other Structures			84,791	
A.5	Miscellaneous Structures	l.s.	1.0	848	
A.6	Street Lighting	l.s.	1.0	1,272	
A.7	Traffic Signal Light	l.s.	1.0	848	
<b>B.</b>	<b>Traffic Management (1% of A.3 – A.7)</b>	p.s.	1.0	890	
<b>C.</b>	<b>Utility Relocation (3% of A.3 – A.7)</b>	p.s.	1.0	2,671	
<b>D.</b>	<b>Indirect Construction Cost</b>			26,615	
	OCM+ Profit (14% of A+B+C)			13,461	
	Vat 12% of A+B+C+ OCM+Profit			13,154	
<b>E.</b>	<b>Estimated Construction Cost</b>				
	<b>SUBTOTAL: A + B + C + D</b>			122,769	
<b>F.</b>	<b>Administrative &amp; Consultancy Cost (10% of E)</b>			12,277	
<b>G.</b>	<b>Contingencies (5% of E+F)</b>	p.s.	1.0	6,752	
<b>H.</b>	<b>ROW and Resettlement (Using Zonal Value)</b>	l.s.	1.0	28,522	
	<b>TOTAL COST (E+F+G+H)</b>			<b>170,320</b>	

Source: JICA study team

## 9.8 TUNNEL SCHEME

### 9.8.1 Proposed Plan and Typical Cross Sections of Tunnel

The beginning and endpoint of the proposed tunnel are located between Roxas Boulevard and Taft Avenue, and Monumento Circle and Balintawak, respectively. The main tunnel consists of 2-lane tunnels (inside diameter D=10.1m) at both sides of the entrance and exit while 3-lane tunnels (inside diameter D=13.3m) shall be used for the entire middle section. 1-lane ramps (inside diameter D=6.7m) shall be provided at four (4) locations. There are no problems regarding horizontal alignment of the tunnel since EDSA does not have steep or extreme variations in alignment. The tunnel should have enough earth covering due to many structures located along EDSA; such as MRT stations and flyovers, which are supported by foundation piles. **Figure 9.8-1** shows the typical cross sections of 3-types of tunnels, and **Figure 9.8-2** shows Tunnel Layout (Plan and Profile).

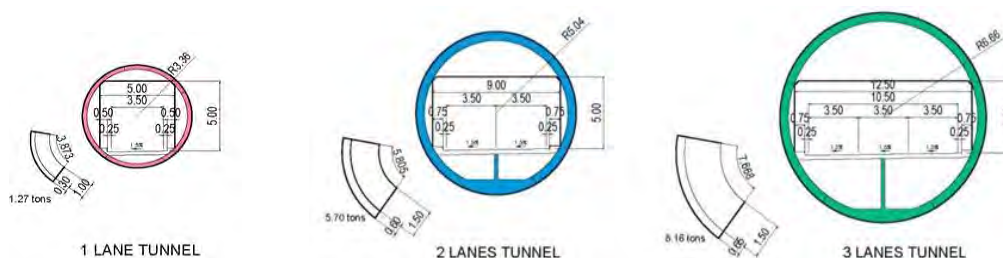

Source: JICA study team

**Figure 9.8-1 Typical Tunnel Section of 3-Types Tunnel**



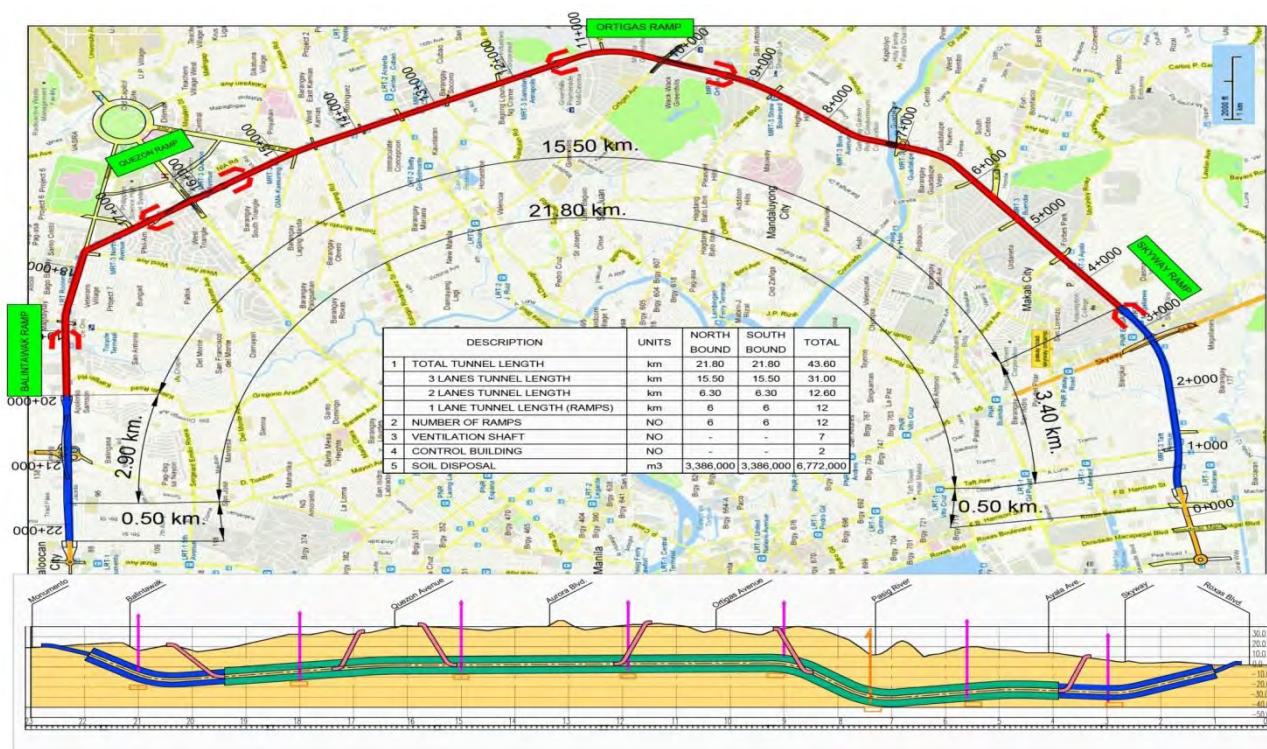

Source: JICA study team

Figure 9.8-2 Tunnel Layout (Plan and Profile)

### 9.8.2 Standard Earth Covering of Tunnel

To have proper distance of earth covering of tunnel from the hindrance of existing structures.

Computation of earth covering underground and under river are as follows:

- Underground : Same diameter of tunnel (1.0 x diameter of tunnel)  
(15m (estimated pile length) + 1.0 x 14.62= 29.6m → 30.0m)
- Under river : Two times of diameter of tunnel (2.0 x diameter of tunnel)  
(2 x 14.62= 29.2m →30.0m)

### 9.8.3 Ramp (Entrance and Exit)

One-lane ramp tunnel provided at four (4) locations as follows;

- a) Between Skyway and Makati
- b) Before and after Ortigas Ave.
- c) Before and after Quezon Ave. and
- d) Between Balintawak and Roosevelt Ave. (South Side of Balintawak)

### 9.8.4 Ventilation System

The main function of the tunnel ventilation system is to discharge the vehicle exhausted fumes and smoke from fire. Airflow shall be diverted into two (2) sections underneath the deck slab of carriageway: one to discharge smoke and the other to take in fresh air which will also be utilized for access of people during an emergency evacuation. Ventilation towers shall be constructed at about

3km intervals because each ventilation tower will not only be used for smoke ventilation but also for electric supply, water deposit, and access for people. General concepts of this system are shown in **Figure 9.8-3** General Concept of Ventilation System.

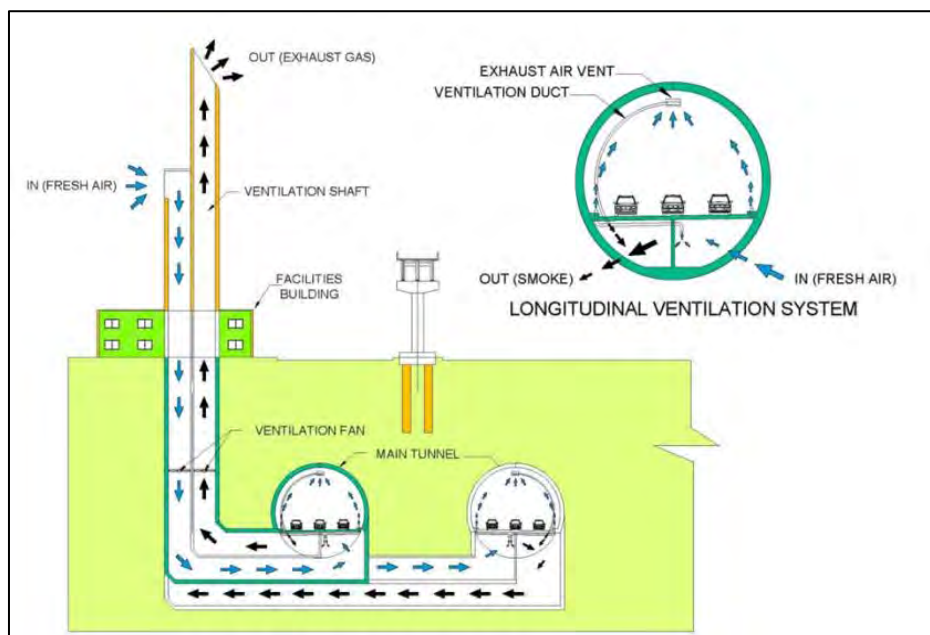

Source: JICA study team

**Figure 9.8-3** General Concept of Ventilation System

### 9.8.5 Shield Shaft

Tunnel excavation will be done by one shield machine per direction between departure vertical shaft and arrival vertical shaft. Shield tunnel construction works are routine works of excavation, assembly of precast concrete segments and grouting between concrete segment and soil. Process of shield tunnel is as shown below.

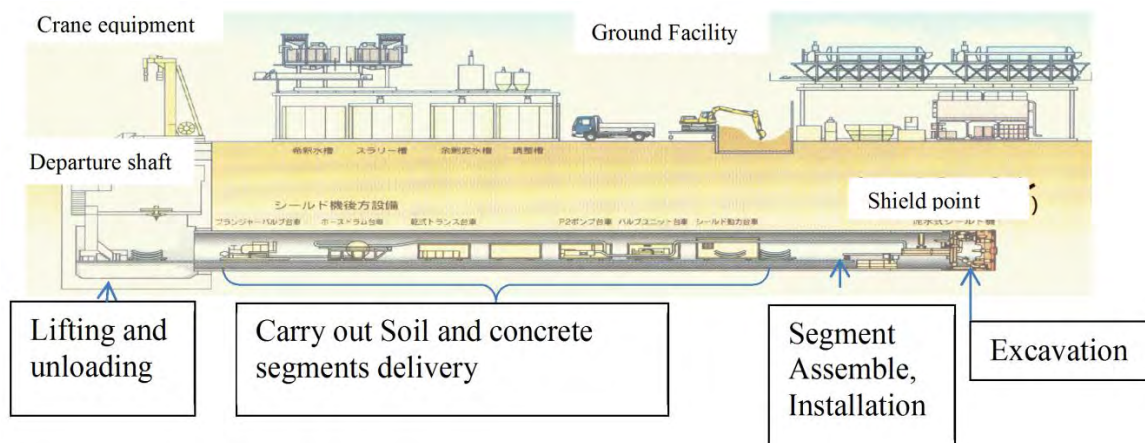

Proper and efficient planning for carrying out and delivery shall be done while also considering minimizing the influence on existing traffic flow due to the utilization of heavy equipment, such as trucks and cranes (Please refer to **Figure 9.8-4** General Concept of Vertical Shaft).

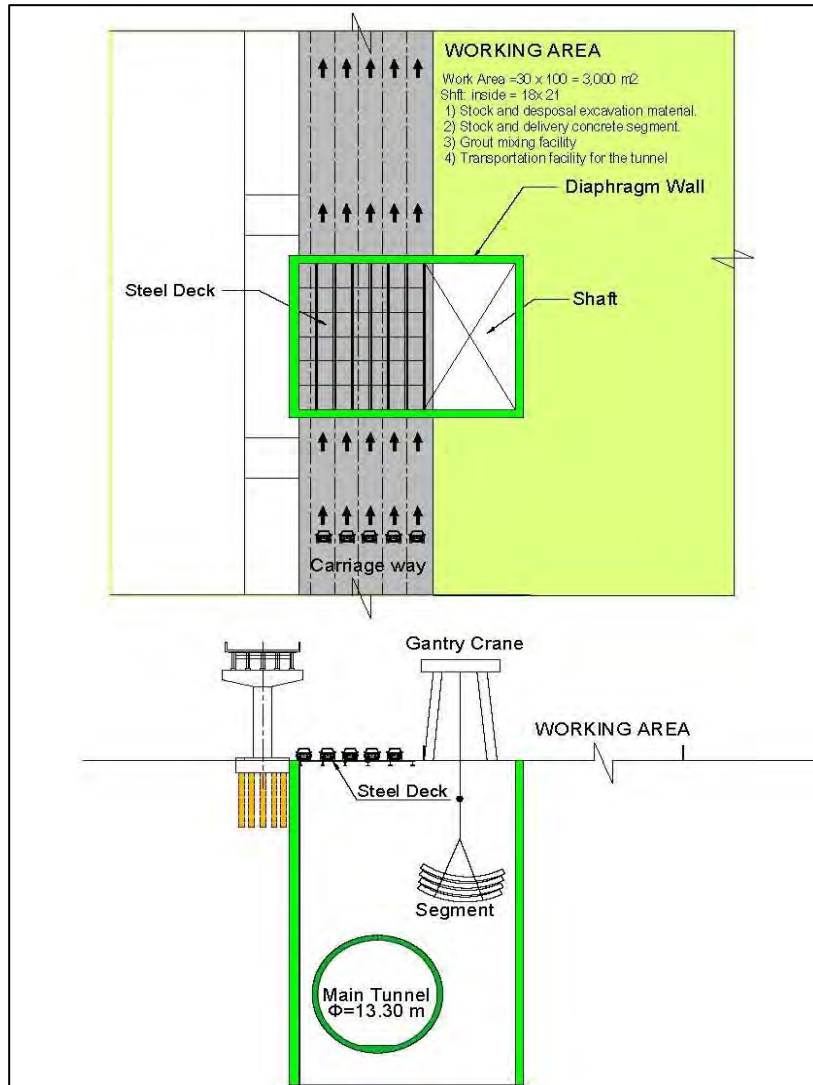

Source: JICA study team

**Figure 9.8-4 General Concept of Vertical Shaft**

### 9.8.6 Required Tunnel Facilities

Based on “installation standards of Emergency Facilities for Road Tunnel” issued by Japan Road Association, proposed tunnel is classified at the most high rank of “AA” which requires the provision of all type of facilities such as:

- 1) Emergency call and warning devices
- 2) Fire extinguisher equipment
- 3) Evacuation facilities
- 4) Communication system
- 5) Water spray system, etc.

### 9.8.7 Construction Schedule

#### (1) Construction Package

In consideration of budget and traffic management, the 22.8 km total length of tunnel shall be divided into 3 packages, as follows:

Package 1: Beginning point to Ortigas Avenue: 8.6 km.

Package 2: From Ortigas avenue to Quezon avenue: 6.5 km.

Package 3: From Quezon Avenue to end point: 7.7 km.

**(2) Overall Construction Schedule**

Based on previous experience of past projects in Japan, the Consultant’s proposed schedule is shown in **Table 9.8-1** Rough Estimated Construction Schedule.

**Table 9.8-1 Rough Estimated Construction Schedule**

Description		Year																			
		1	2	3	4	5	6	7	8	9	10	11	12	13	14	15	16	17	18	19	20
Package 1																					
Construction	Design & Bidding	█	█																		
	Land Acquisition		█	█																	
	Preparations			█	█																
	Shaft				█	█															
	Tunnel work					█	█	█													
	Tunnel connection							█	█												
	Civil Works						█	█	█												
	Facilities								█	█											
Package 2																					
Construction	Design & Bidding							█	█												
	Land Acquisition								█	█											
	Preparations									█	█										
	Shaft										█	█									
	Tunnel work											█	█								
	Tunnel connection												█	█							
	Civil Works													█	█						
	Facilities														█	█					
Package 3																					
Construction	Design & Bidding														█	█					
	Land Acquisition															█	█				
	Preparations																█	█			
	Shaft																	█	█		
	Tunnel work																		█	█	
	Tunnel connection																			█	█
	Civil Works																				█
	Facilities																				

Source: JICA study team

Note: 1) Conditions for preparation of above rough estimated schedule

- (a) Excavation by one shield machine is estimated to be 18m/day which does not include period of assembly and dismantling of shield machine and maintenance and replacement of parts of shield machine.
- (b) Maintain 5-lanes per direction at-grade traffic along EDSA.
- (c) R.O.W acquisition to be completed before implementation starts.

2) Issues

- (a) Need to find disposal area of 7 million cubic meter of excavated soil
- (b) Traffic management due to mobilization of big number of trucks, trailer and, concrete mixer trucks, etc.

**9.8.8 Cost Estimate**

**(1) Condition for Cost Estimation**

1. Rough cost will be estimated based on completed projects and past experiences in Japan considering similar site condition of EDSA
2. Exchange rate between peso and yen is 1 peso = 1.90 yen
3. Instead of lease, 10m x 1,000m = 10,000m<sup>2</sup> of R.O.W acquisition of ramp will be considered.
4. Vertical Shaft will be constructed phase by phase to minimize traffic congestion along EDSA. The present 5-lanes traffic and side walk will be maintained during the construction with the provision for steel temporary deck plate on the top of vertical shaft. 3,000m<sup>2</sup> of temporary construction yard beside of vertical shaft will be considered as land rental.
5. Land acquisition for ventilation shaft will be considered.
6. 26% is commonly used as indirect cost for general construction projects in the Philippines. However, 30% will be used as indirect cost considering that this will be the first time to construct a major tunnel in the Philippines and especially in a major Urban City environment.

7. Rough Estimate Cost shall consider following five (5) schemes:

Scheme-1	Entire Section of both directions	
	Main tunnel (3-lane)	: 15.5 km x 2-direction
	Entrance/exit at both end (2-lane)	: 7.3 km x 2-direction
Scheme-2	Package-1 of Scheme-1	
	Main tunnel (3-lane)	: 4.7 km x 2 direction
	Entrance/exit (2-lane)	: 3.9 km x 2 direction
Scheme-3	Only one (1) direction of scheme-1	
	Main tunnel (3-lane)	: 15.5 km x 1-direction
	Entrance/exit at both end (2-lane)	: 7.3 km x 1-direction
Scheme-4	Construct 2-lane for both directions	
	Maintain tunnel (2-lane)	: 22.8 km x 2-direction
Scheme-5	Only one (1) direction of scheme-4	
	Main tunnel (2-lane)	: 22.8 km x 1-direction

8. Summary of rough estimated cost of each scheme is shown in **Table 9.8-2**.



**Table 9.8-2 Summary of Rough Estimate cost of each Schemes**

Description	Scheme-1		Scheme-2		Scheme-3		Scheme-4		Scheme-5	
	Entire Section of both directions Main Tunnel (3-Lanes) = 15.5km x 2 directions Entrance/Exit at both end 2-Lanes = 7.3km x 2 directions		Package 1 of Scheme-1 Main Tunnel (3-Lanes) = 4.7km x 2 directions Entrance/Exit at both end 2-Lanes = 3.9km x 2 directions		Only (1) Direction of Scheme-1 Main Tunnel (3-Lanes) = 15.5km 1-direction Entrance/Exit at both end 2-Lanes = 7.3km 1-directions		Construct 2-lane Tunnel both Direction Main Tunnel (2-lanes) = 22.8 km x 2 directions		Only (1) Direction of Scheme-4 Main Tunnel (2-lanes) = 22.8 km 1-directions	
	Yen	Peso	Yen	Peso	Yen	Peso	Yen	Peso	Yen	Peso
I. Construction Cost										
A. Direct cost	4,549	2,358	1,688	887	2,377	1,251	3,360	1,768	1,743	917
Main tunnel	2,779	1,462	971	511	1,389	731	1,873	986	937	493
Ramp Tunnel	960	505	384	202	480	253	960	505	480	253
Shield shaft	73	4	37	19	37	19	37	19	18	9
Ventilation shaft	480	252	206	108	343	181	312	164	218	115
Facilities	257	135	90	47	128	67	178	94	90	47
B. Central Cost	90	48	34	18	48	26	68	36	34	18
Traffic Management (1% of A)	45	24	17	9	24	13	34	18	17	9
Utility Relocation (1% of A)	45	24	17	9	24	13	34	18	17	9
C. Indirect cost (30% of A+B)	1,392	722	517	272	728	383	1,028	541	533	281
D. Sub total (A + B + C)	6,031	3,128	2,239	1,177	3,153	1,660	4,456	2,345	2,310	1,216
E. VAT (12% of D)	724	375	269	141	378	199	535	281	277	146
F. Construction cost (D+E)	6,755	3,503	2,508	1,318	3,531	1,859	4,991	2,626	2,587	1,362
G. Consultancy Cost (10% of F)	676	350	251	132	353	186	499	263	259	136
H. Land acquisition including compensation for structures	586	308	214	113	304	162	523	278	277	147
I. Contingency Cost (5% of F+G)	372	193	138	73	194	102	275	144	142	75
<b>Total Cost (F+G+H+I)</b>	<b>8,389</b>	<b>4,354</b>	<b>3,111</b>	<b>1,636</b>	<b>4,382</b>	<b>2,309</b>	<b>6,288</b>	<b>3,311</b>	<b>3,265</b>	<b>1,720</b>

Source: JICA study team

## CHAPTER 10

### SEMINAR ON LATEST JAPANESE ROAD AND BRIDGE CONSTRUCTION TECHNOLOGY

#### 10.1 OBJECTIVES

The objective of the seminar is to introduce the latest Japanese technologies of road and bridge construction for understanding technical supervision of STEP scheme for the proposed flyover project and also Filipino engineers to apply these to on-going and/or future projects. Said technologies are related to tunnel construction, asphalt pavement, rapid construction methods, bridge rehabilitation and improvement and quality control systems.

#### 10.2 SEMINAR PROGRAM

Venue : H<sub>2</sub>O Hotel, Manila City      Date : March 6 and 7, 2012

- Day 1 (6<sup>th</sup> March)

TIME	PROGRAM/TOPICS		SUB-TOPICS	SPEAKER
8:30 - 9:00	Registration		-	DPWH Secretariat / KEI
9:00 - 9:05	Philippine National Anthem		-	
9:05 - 9:15	Message		-	DPWH Secretary Rogelio L. Singson
9:15 - 9:20	Welcome Address		-	Mr.Takahiro SASAKI Chief Representative JICA PHILIPPINES OFFICE
9:20 - 9:50	Statement / Briefing		Road Infrastructure Plans for Metro Manila	DPWH Assistant Secretary Maria Catalina E. Cabral
9:50 - 10:10	<i>Break Time &amp; Photo Session</i>			
10:10 - 10:40	Seminar-1	Introduction of Japanese Road Technologies	-	Mr.Tomohiro HASEGAWA Director for International Affairs, Road Bureau Ministry of Land, Infrastructure, Transport and Tourism(MLIT)
10:40 - 10:50	<i>Break Time</i>			
10:50 - 11:10	Seminar-2	Tunnelling Construction Techniques	1. Urban Tunnels (Harmonica Construction, Jacking and Shield Methods)	Mr.Yutaka HIBIYA The Overseas Construction Association of Japan, Inc. (TAISEI CORPORATION)
11:10 - 11:30			2. Mountain Tunnels (NATM)	Dr.Satoru AMANO The Overseas Construction Association of Japan, Inc. (OBAYASHI CORPORATION)
11:30 - 11:50			Question / Answer	
11:50 - 13:20	<i>Lunch Time</i>			
13:20 - 13:40	Seminar-3	Pavement Technology	1. Pavement Quality Control During Construction	Dr.Tsutomu ISHIGAKI The Japan Road Contractors Association (NIPPO CORPORATION)
13:40 - 14:00			2. Porous Asphalt Pavement and Advanced Pavement Technology	Dr.Katsura ENDO The Japan Road Contractors Association (NIPPON ROAD CO.,LTD.)
14:00 - 14:20			3. Pavement Management in NEXCO	Dr.Keizo KAMIYA NIPPON EXPRESSWAY RESEARCH INSTITUTE CO.,LTD.
14:20 - 14:50			Question / Answer	
14:50 - 15:00	Information		-	Mr.Yuuki ARATSU Deputy Director General, and Group Director for Transportation and ICT JICA Economic Infrastructure Department

• DAY2(7<sup>th</sup> March)

TIME	PROGRAM/TOPICS		SUB-TOPICS	SPEAKER
8:30 - 9:00	Registration		-	DPWH Secretariat / KEI
9:00 - 9:20	Seminar-4	Rapid Construction Methods (Concrete Bridge)	1. Rapid Bridge Construction Method Applying Precast Segments	Mr.Hideyuki TAKEDA The Overseas Construction Association of Japan, Inc. (KAJIMA CORPORATION)
9:20 - 9:30			Question / Answer	
9:30 - 9:40	<i>Break Time</i>			
9:40 - 9:50	Seminar-5	Rapid Construction Methods (Steel bridge)	1. Introduction of the Japan Bridge Association	Mr.Ichiro KITAGAKI THE JAPAN BRIDGE ASSOCIATION Director Chairman of International Business Special Committee (KOMAIHALTEC INC.)
9:50 - 10:10			2. Viaduct in Urban Area and Steel Structures	Mr.Taku HIRAI THE JAPAN BRIDGE ASSOCIATION International Business Special Committee (YOKOGAWA BRIDGE CORPORATION)
10:10 - 10:30			3. Rapid Construction of Steel Bridges	Mr.Hideyuki KAMAI THE JAPAN BRIDGE ASSOCIATION International Business Special Committee (MITSUI ENGINEERING & SHIPBUILDING CO.,LTD.)
10:30 - 10:50			4. Chronology of Seismic Design Criteria and Survey Report of the Great East Japan Earthquake	Mr.Tatsuhiko KASAI THE JAPAN BRIDGE ASSOCIATION Executive Head of Maintenance Committee (MIYAJI ENGINEERING , INC.)
10:50 - 11:20			Question / Answer	
11:20 - 12:50	<i>Lunch Time</i>			
12:50 - 13:10	Seminar-6	Bridge Rehabilitation and Improvement Technology	1. Repair and Reinforcement of Concrete Bridge Technology & Seismic Resistance and Isolation Technology	Mr.Yoshihiko TAIRA The Overseas Construction Association of Japan, Inc. (Sumitomo Mitsui Construction Co., Ltd)
13:10 - 13:30			2. Maintenance of Steel Bridges and Urban Expressway Management	Mr.Hiroyuki WADA METROPOLITAN EXPRESSWAY CO.,LTD.
13:30 - 13:50			Question / Answer	
13:50 - 14:00	<i>Break Time</i>			
14:00 - 14:20	Seminar-7	Quality Control System Technology	1. Quality Control of Highway and Bridge Construction	Mr.Nobuhiro HONDA The Overseas Construction Association of Japan, Inc. (SHIMIZU CORPORATION)
14:20 - 14:30			Question / Answer	
14:30 - 14:40	Fill up Questionnaire		-	DPWH Secretariat / KEI
14:40 - 14:50	Wrap-up		Conclusion and Recommendations	DPWH Under Secretary Raul C. Asis
14:50 - 15:00	Closing Statement		-	Mr.Yuuki ARATSU Deputy Director General, and Group Director for Transportation and ICT JICA Economic Infrastructure Department

### 10.3 ATTENDANCE

#### (1) PHILIPPINES

Attendance from DPWH and other Offices are shown in Table below:

Attendance	Day 1 (March 6, 2012)	Day 2 (March 7, 2012)
<b>DPWH Secretary Under Secretary Assistant Secretary</b>	8	8
<b>Regional Directors</b>	16	15
<b>Bureau/Service Directors</b>	13	13
<b>Project Management Office</b>	23	24
<b>Government Agencies</b>	4	4
<b>Local Government Units</b>	13	11
<b>Private Institutions and Academe</b>	7	5
<b>Total</b>	<b>84</b>	<b>80</b>

#### (2) JAPAN

The list of the Guest Speakers is shown in the aforementioned Seminar Program. The other attendees from Japan are as follows:

- Ministry of Land Infrastructure, and Transport and Tourism : 1 person
- Embassy of Japan in the Philippines : 1 person
- JICA Head Office : 3 persons
- JICA Manila Office : 2 persons
- JICA Expert : 1 person

### 10.4 QUESTION AND ANSWER RESULTS

		<u>Q&amp;A</u>
Seminar – 1	Introduction of Japanese Technologies	-
Seminar – 2	Tunneling Construction Techniques	9
Seminar – 3	Pavement Technology	6
Seminar – 4	Rapid Construction Method (Concrete Bridge)	2
Seminar – 5	Rapid Construction Method (Steel Bridge)	6
Seminar – 6	Bridge Rehabilitation and Improvement Technology	5
Seminar – 7	Quality Control System	1

## **10.5 SUMMARY AND ANALYSIS OF QUESTIONNAIRE**

The answers given on the questionnaire sheets showed the participants' high interest on the high level of technology that was imparted by each topic, as well as their satisfaction on the management of the Seminar as a whole.

Thirty nine (39) Questionnaire were submitted among the attendees which are summarized below.

Q1- In this seminar, which subject interests you the most?

Among the seven (7) topics, the most interesting topics discussed during the seminar were on: Tunneling Construction Technology ranked first with 17 persons, second was Pavement Technology, followed by Rapid construction Method (steel bridge) as 3 third in rank.

Q2- What subjects would you consider for future projects or activities, and why?

Among the seven (7) topics, what is to be considered for future projects and activities are Tunneling Construction Techniques, Pavement Technology ranked the first with 10 persons each, the second was Rapid Construction Method (Steel Bridge), followed by Rapid Construction Method (Concrete Bridge) as 3 third 4 in rank. This answer was similar to question-1 above.

Q3- Please give your comments about the seminar:

Almost all of the attendants were satisfied with each topic, imparted knowledge of new technology, excellent handouts and the way how to manage the seminar. Some useful comments were presented: time given to each topic was relatively short; presenters should further explain how the new technology will be applied and effective in the Philippines context; its trainings in Japan should be arranged, and venue and comfort rooms were narrow/a little.

## **10.6 CONCLUSION**

The Seminar was satisfactorily conducted because the Guest Speakers lectured on interesting topics and a lively exchange of questions and answers took place between the Guest Speakers and the participants during the lecture.

The following are the likely reasons why the Seminar was satisfactorily conducted:

- a) Interesting topics were taken up for discussing
- b) Presentation of speakers was given using interesting and excellent materials
- c) Arrangement for inviting relevant offices regarding road and bridge construction was properly done.
- d) Almost all of the top officials from DPWH attended, including the Honorable DPWH Secretary, attended.
- e) Issuing Certificates of Attendance was good arrangements

f) Invitation letters were issued in the name of the Honorable DPWH Secretary

The following suggestion for improving the next seminar are from comments on the questionnaire:

- a. Should have given more time for each topic (20 minutes presentation is a bit short).
- b. Should have considered more applications and knowledge under Philippine setting.
- c. Should have provided more comfortable conditions in preparing food and arranging sufficient number of toilets for the attenders

The following pictures present highlights of attendance of top officials of DPWH, Guest Speaker, and Japanese experts/resource persons in the Seminar hall.