

6. References

The Preparatory Survey for the Project of Micro-Hydroelectric Power Generation in Metropolitan Area of Tegucigalpa in the Republic of Honduras

Brief on First Field Survey

1. Schedule of the Study

Item \ Year	2012						2013		
	Jul.	Aug.	Sep.	Oct.	Nov.	Dec.	Jan.	Feb.	Mar.
Preparation of the survey in Japan	□								
First Field Survey in Honduras									
Analysis in Japan (Preparation of Draft report in Japan)				□					
Second Field Survey in Honduras						■			
Preparation and Submission of F/R							□		
Submission of each report to JICA		▼ Ic/R				▼ Df/R			F/R ▼

Remarks: □ work in Japan, ■ work in Honduras, ▼ Submission of Ic/R, Df/R, F/R to JICA
 Ic/R: Inception Report, Df/R: Draft final Report, F/R: Final Report

2. Licenses / Permission / Approval for Required for Power Generation Business

Existing condition and forecasts/problems for Licenses / Permission / Approval for Required for Power Generation Business are summarized in the following tables.

3. Study Results

3.1 Concepcion Site

The following essential data for power generation plan are collected

- Daily intake water data for 10 years
- Daily dam level data for 10 years
- Booster pump operation condition
- Pressure measurement for various discharge at several points
- Final drawings of existing pipe line, intake, dam etc.

The following study will be conducted according to flow chart of optimum study.

- Selection of new pipeline, steel pipe vs PVC pipe
- Optimum diameter of new pipeline
- Location of connecting point of existing and new pipe line s

The Concepcion site has no difficulties for power generation plan and basic design.

The new pipeline route are basically located along the road and the connecting point of existing and new pipe lines are determined according to the topographic condition and around the boundary from 1100mm diameter to 900mm diameter pipes.

Licenses / Permission / Approval for Required for Power Generation Business

Required Licensing	Applicant	Acknowledge of licensing	Existing Conditions	Forecasts / Problems
Power Generation Operation License	SERNA (SANAA)	Cabinet	SANAA is confirming the procedures regarding the power generation operation license to CNE.	SERNA is to submit the documents for the cabinet approval with Environmental license and Water Right.
Water Contract	-	-	SANAA has water right utilized for water supply at Concepcion and Picacho sites. So SANAA understands it is not necessary to obtain further water right for power generation utilization.	SERNA shall confirm its water right.
Environmental License	SANAA	SERNA or Tegucigalpa city	Picacho site has high possibility to fall under Category 1 (low impact projects), which applies to Hydroelectric Power projects less than 3MW. Picacho powerhouse site is not inside national park areas and is properties of several private land owners. Concepcion site is not inside the protected area and is located in the public roads and private lands partly.	After submission of F01 for Category 1, the license will be issued within 15 days. F01 is to be fulfilled after the submission of Study report (Dec. 2012) and acquisition of necessary lands. The lands of Picacho powerhouse area are private ones not property of national park. The license will be obtained before E/N.
Renewable Resource Law Application	Contractor	SANAA	Not necessary	
Power Selling Agreement	SERNA (SANAA)	CNE	SANAA is confirming the procedures regarding the power selling agreement to CNE under guidance of ENEE. The electricity generated by the Hydroelectric Power plants is to be sold to ENEE.	SANAA is to submit the relevant document to SERNA. SERNA is to submit the documents for the approval of ENEE.
Construction License	Contractor	Tegucigalpa city	Construction license requires Environmental license and construction plan including environmental measures.	The Contractor will obtain the license before construction
Grid Connection / System Interconnection	SERNA (SANAA)	ENEE	SANAA and ENEE agreed that the powerhouse is to be connected directly to the nearby ENEE grid. E/M Equipment can be connected to ENEE system by review and approval by ENEE. SANAA is preparing draft documents regarding the grid connection.	SANAA is to submit the relevant document to SERNA, then SERNA will submit it for approval from ENEE
Tax Exemption	Contractor	SANAA	The procedures of tax exemption to such as import duties, VAT were obtained.	The Contractor shall apply to tax exemption according to the procedures.
Land Acquisition	SANAA	Land Owner	Picacho powerhouse site is the land of several land owners. Powerhouse and part of water pipeline are located in the lands of private owners in Concepcion site. Most of pipeline portion is under the existing roads.	The land actuation by SANAA shall be completed until construction of the Work.
Road Space Occupation Permission	Contractor	Tegucigalpa city	The road occupation approval during construction period is responsible for the Tegucigalpa city.	The Contractor shall submit the permission to the Tegucigalpa city before the construction

*CNE: Comisión Nacional de Energía

Power Generation Plan of Concepcion Site

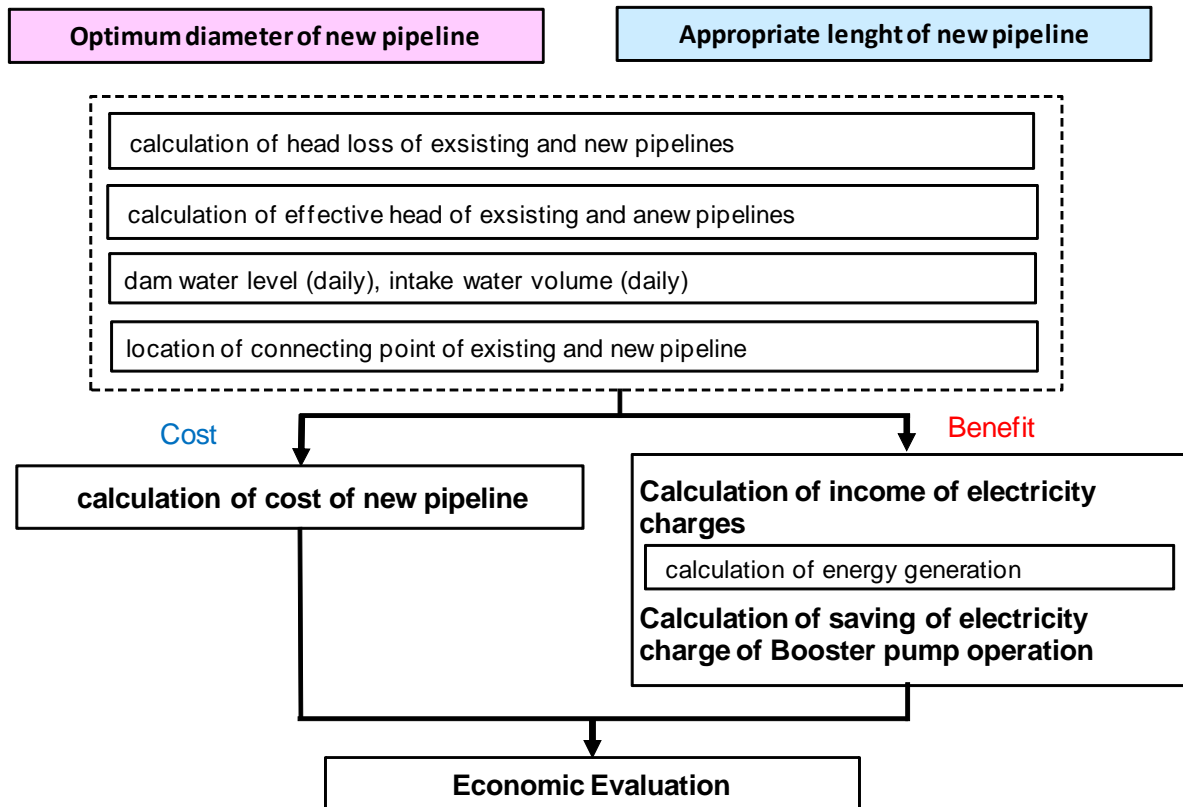

Flow Chart of Optimum Study

$$P_{max} = 9.8 \eta Q_{pmax} H_e$$

where, P_{max} :Max Output (kW)
 Q_{pmax} :MaxPower discharge(m³/sec)
 H_e :Effective head in case of Maxdischarge(m)
 η :efficiency(=0.8, turbine-generator)

$$E = \sum 9.8 \eta(i) Q_p(i) H_e(i) h$$

where, E:Energy Generation(kWh)
 $Q_p(i)$:power discharge (m³/sec)
 h :hour

Calculation of Max. Power Output and Energy Generation

Fluctuation of Daily Dam Water Level

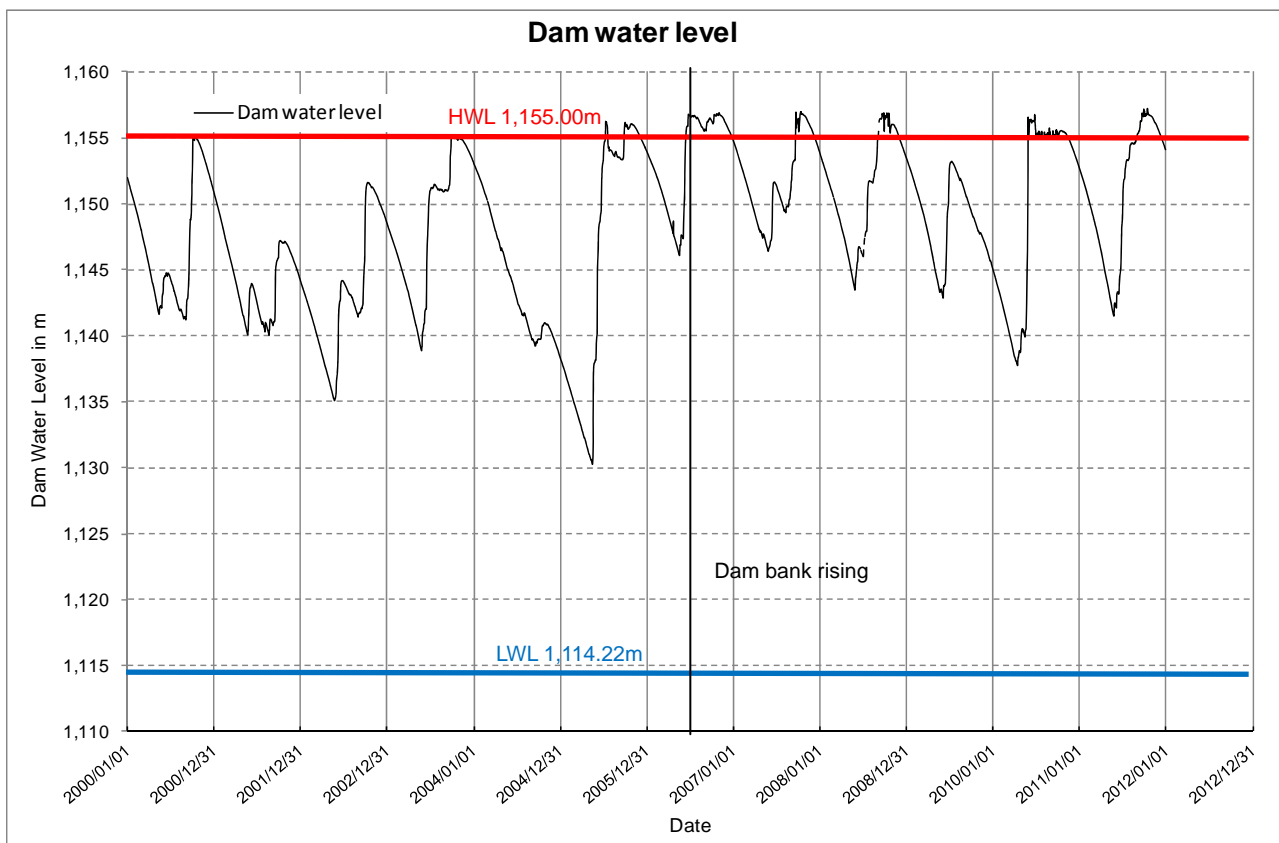

Annual Maximum/Minimum/Average Dam Water Level

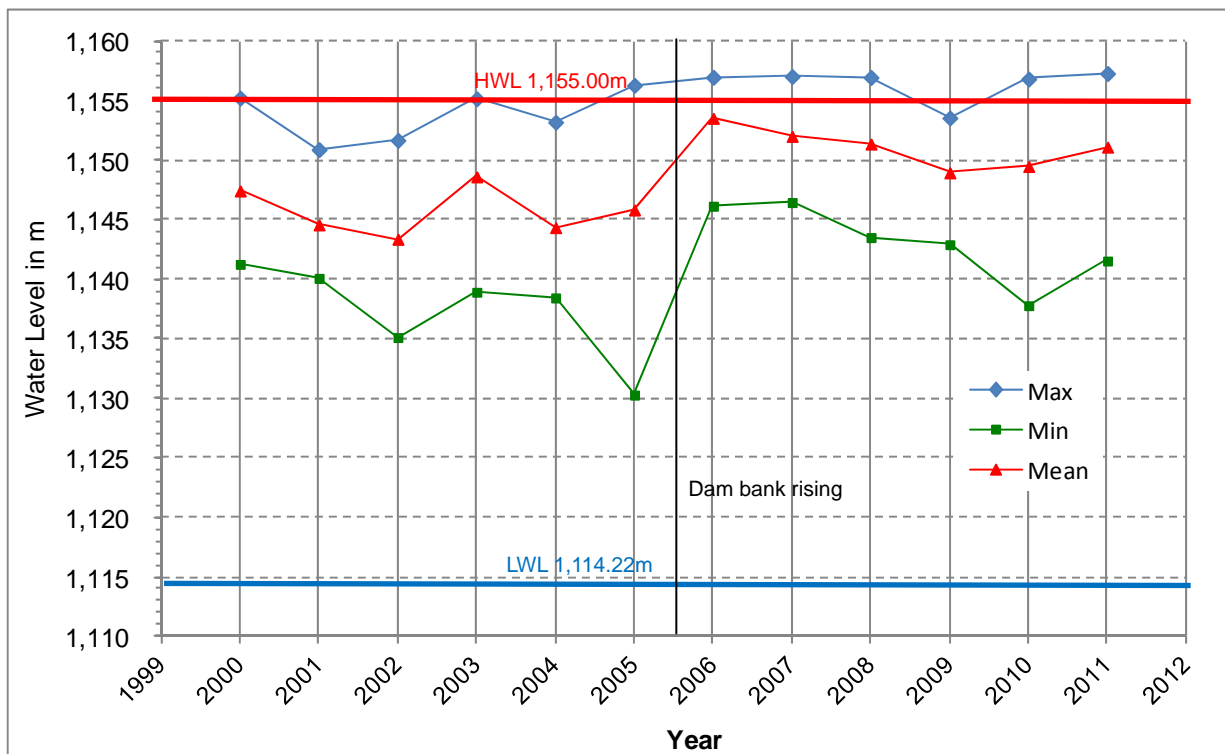

Fluctuation of Dam Water Level

Fluctuation of Daily Dam Intake Water

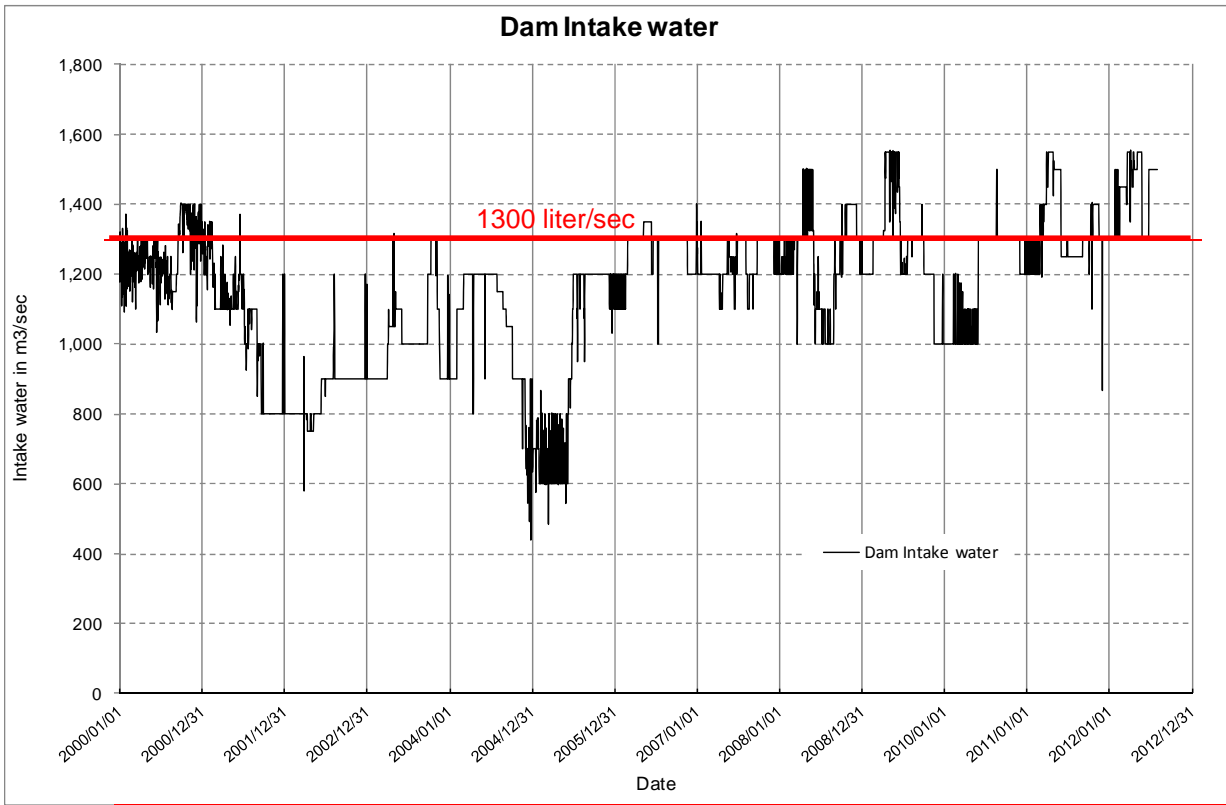

Annual Maximum/Minimum/Average Intake Water

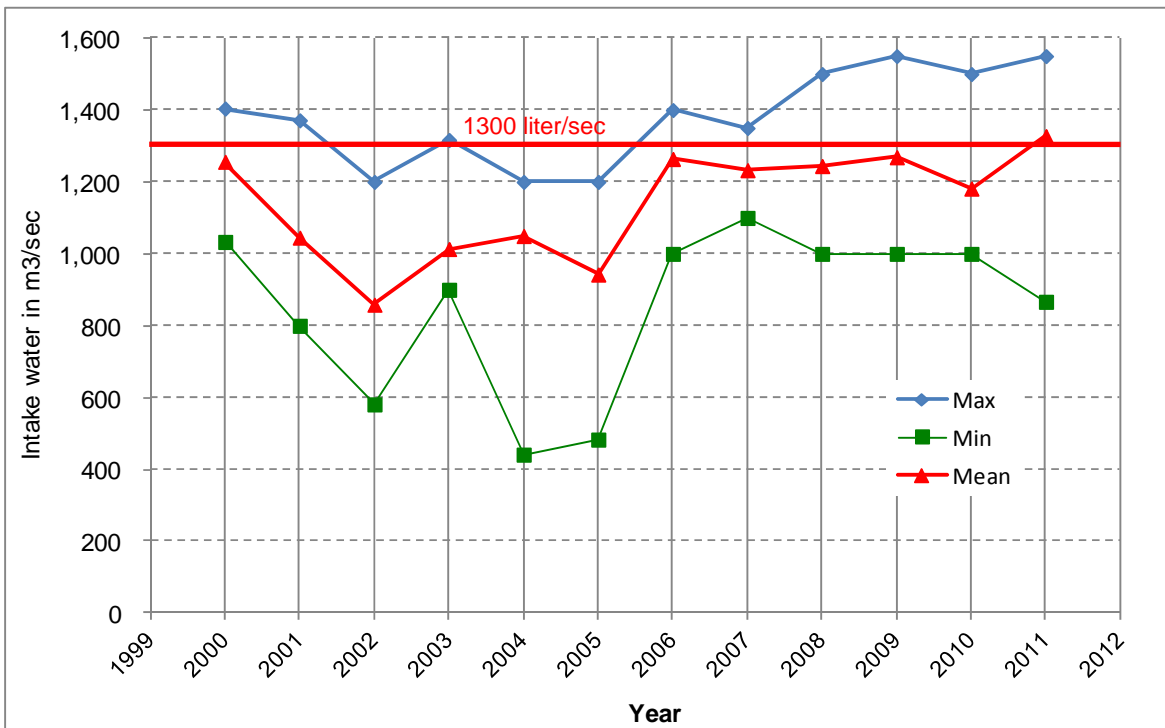

Fluctuation of Intake Water Volume

Duration Curve (2000-2007)

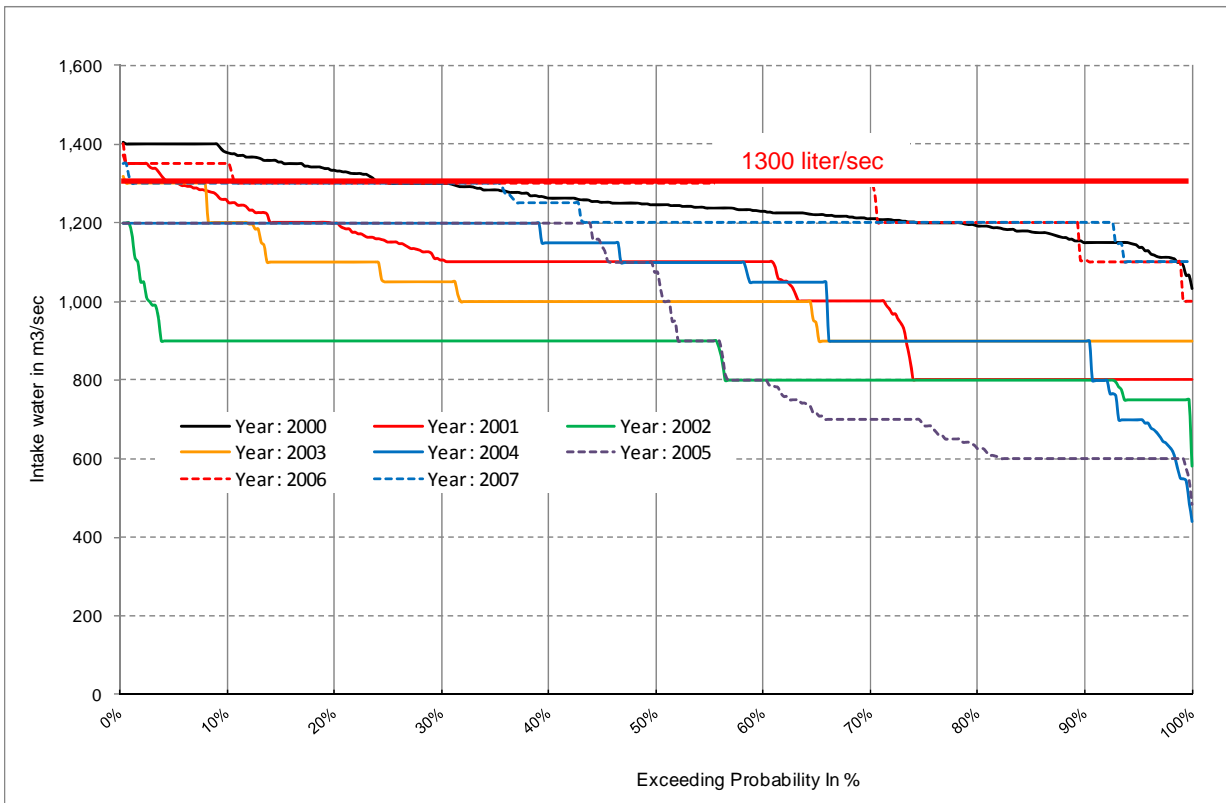

Duration Curve (2008-2011)

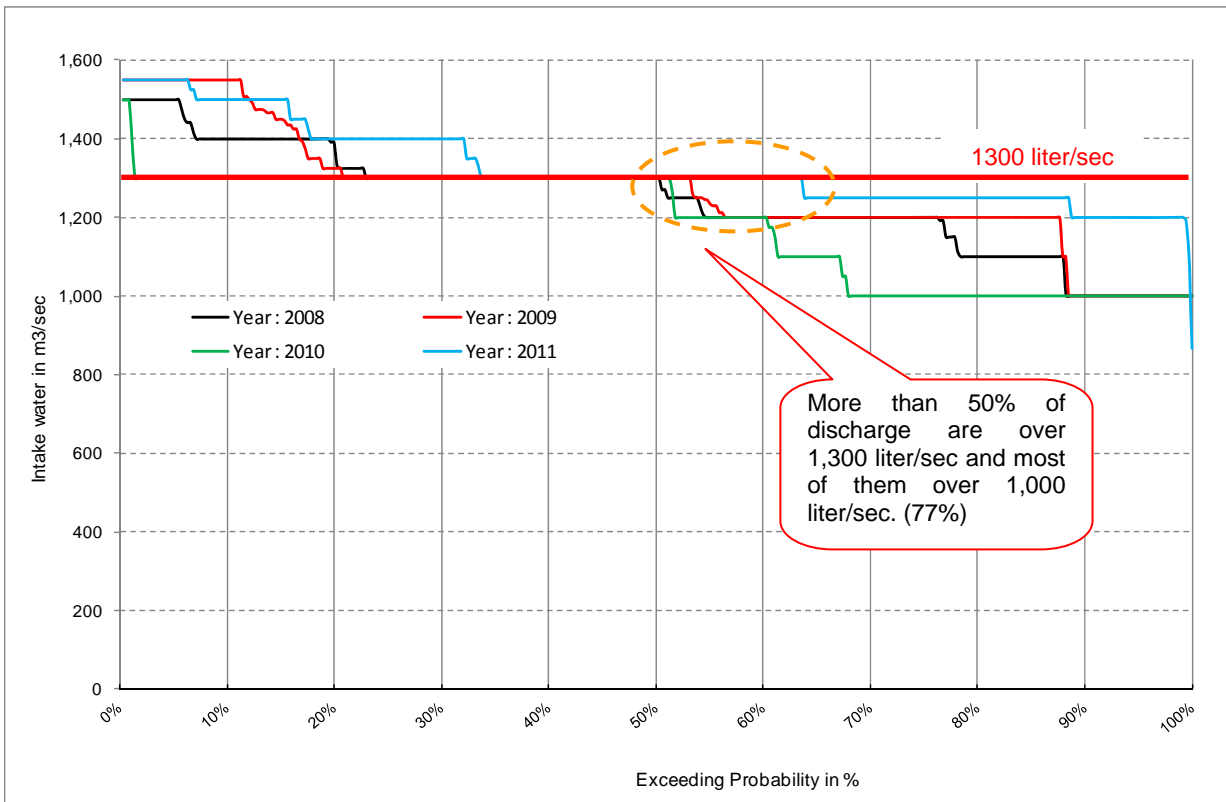

Fluctuation of Discharge Data

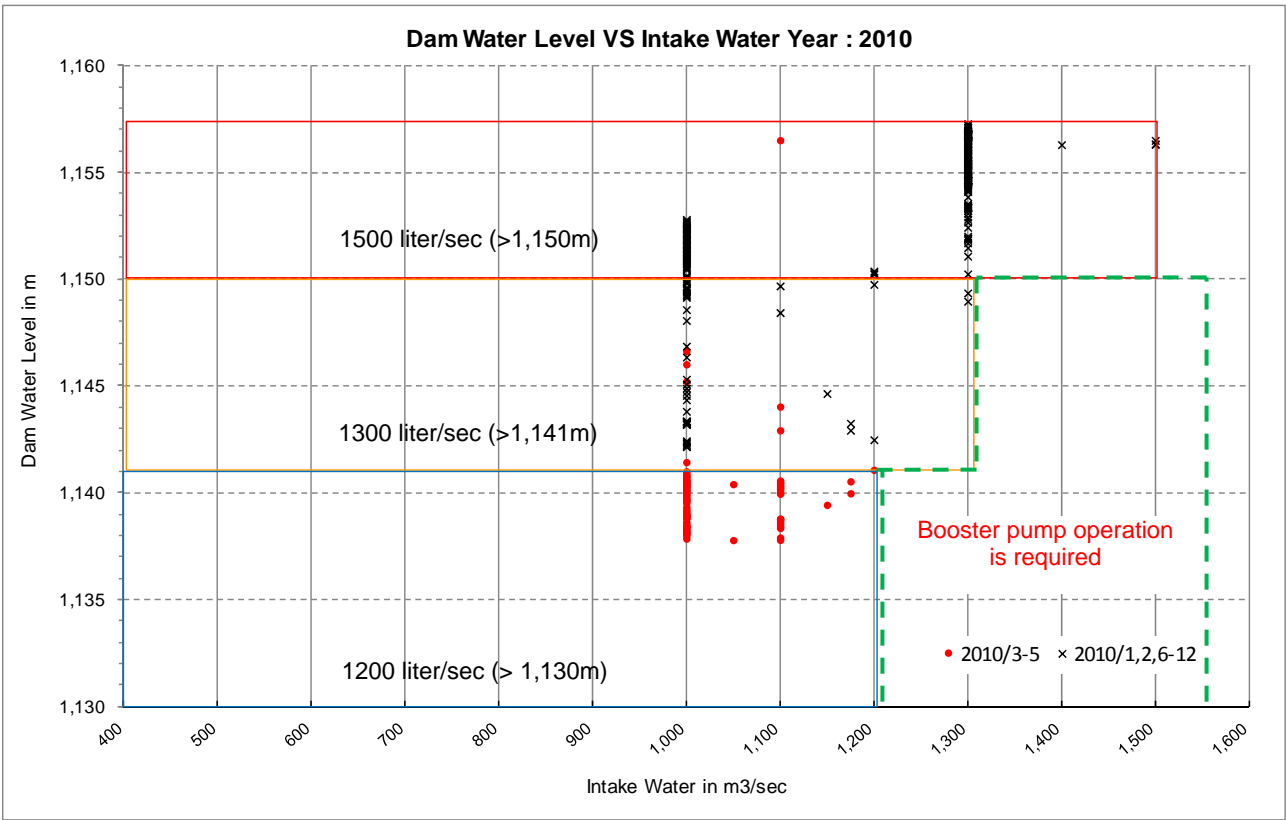
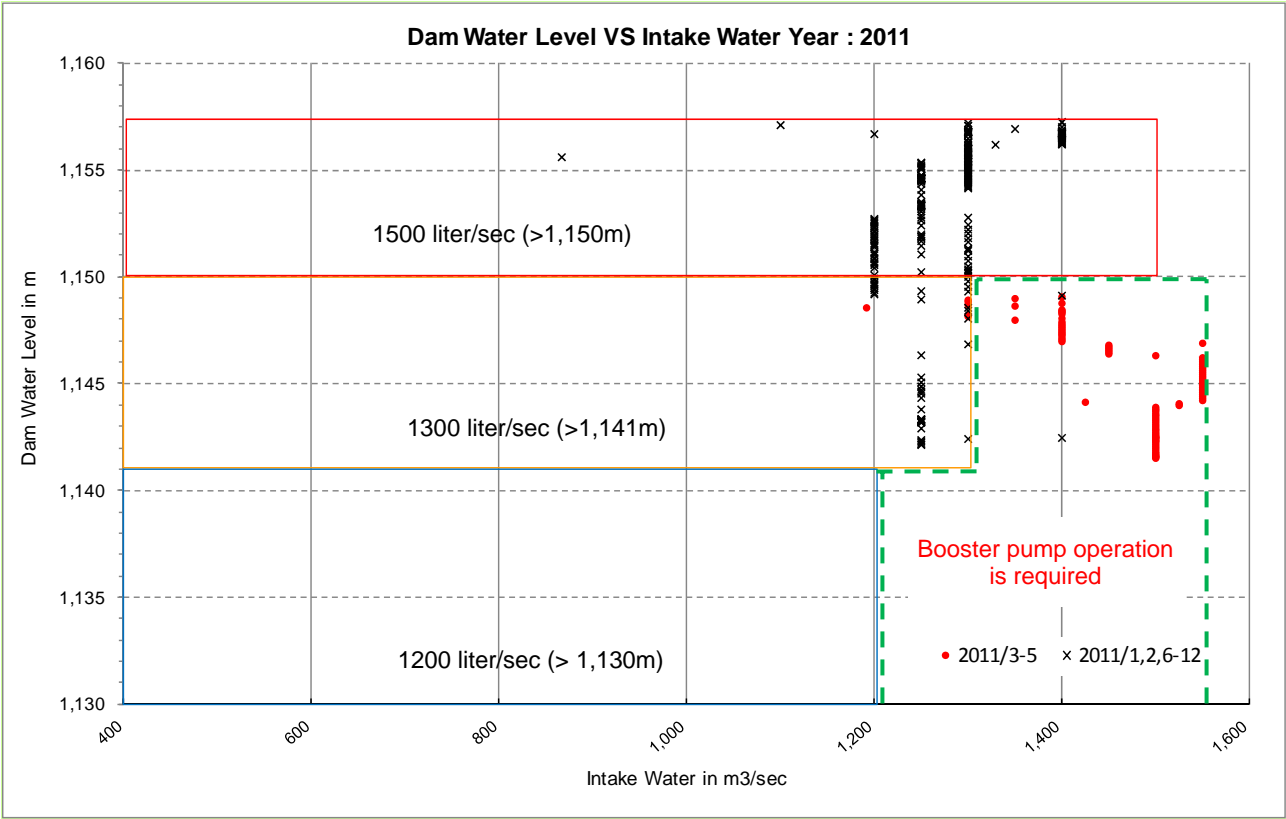

Booster Pump Operation Condition

Head vs Discharge at Aerator (ST 5,500m)

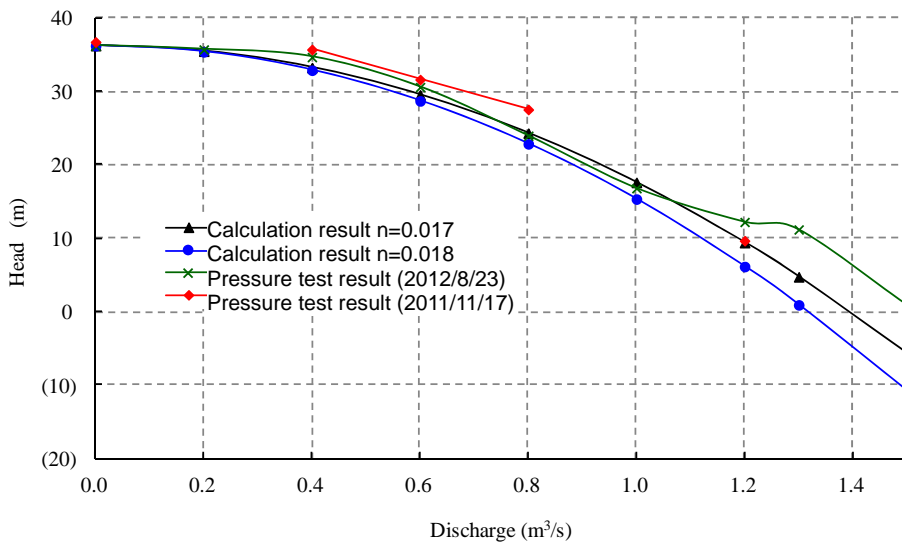

Head vs Discharge at P-2 (ST 4,400m)

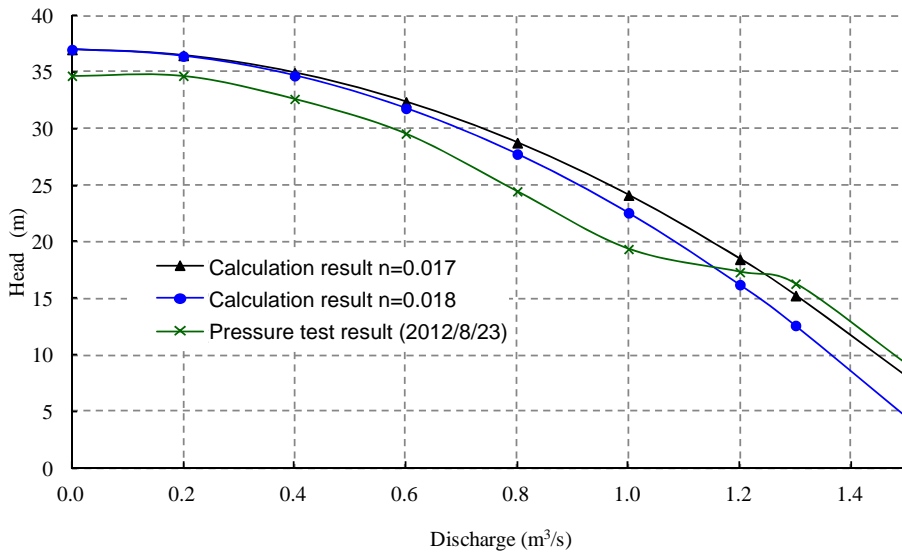

Head loss vs Discharge at Aerator (ST 5,500m)

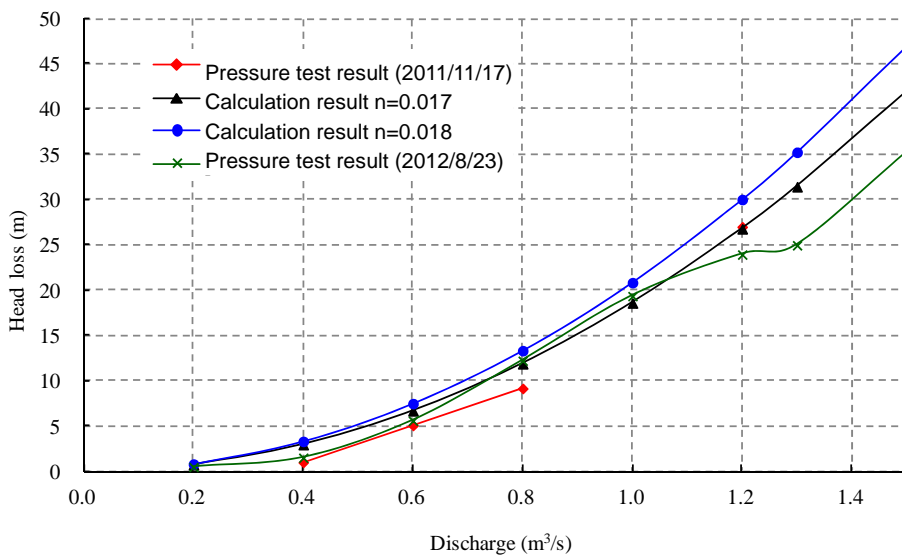

Pressure Measurement Results along the Pipe line



Aerator



Concepcion Powerhouse Site

Conception Site : New Pipeline Route



Aerator-PI87

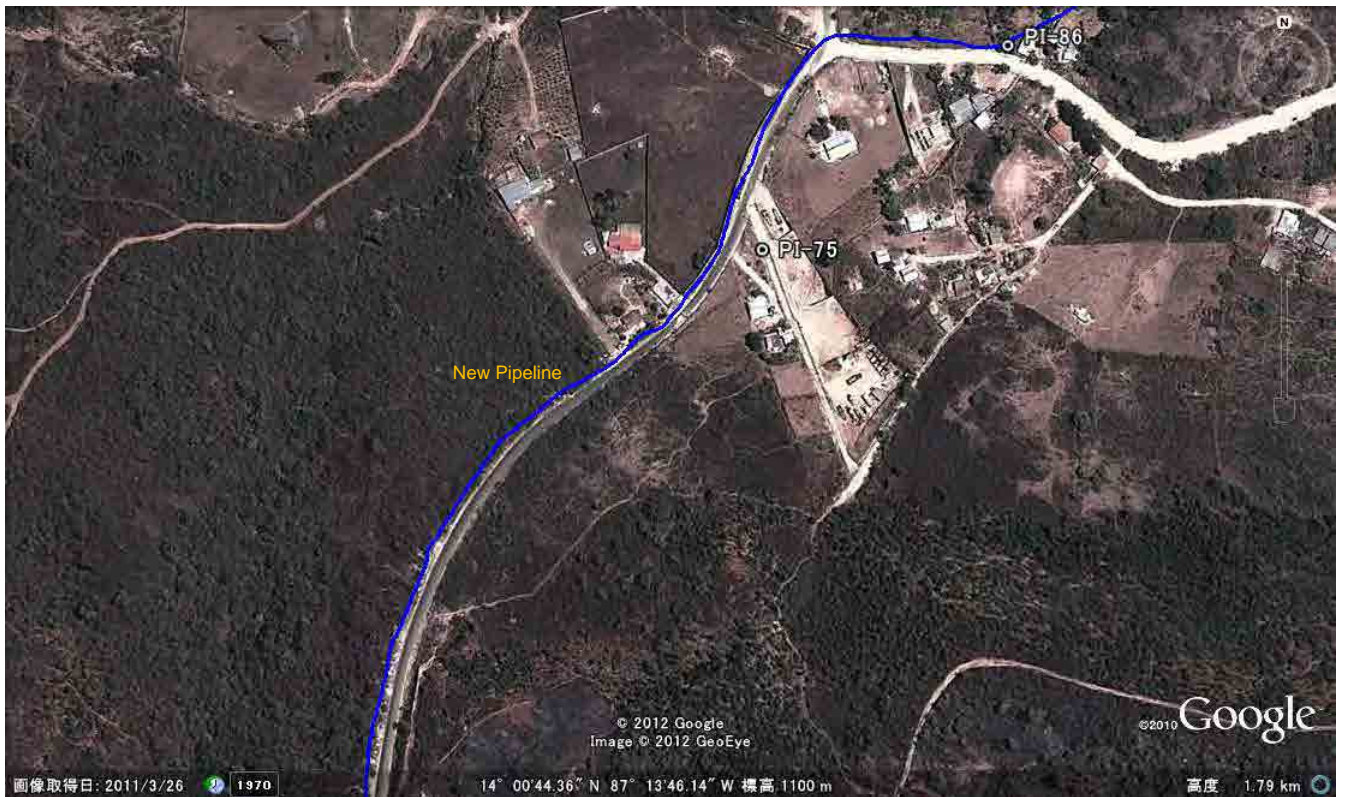

PI87 – P73

Concepcion Site : New Pipeline Route

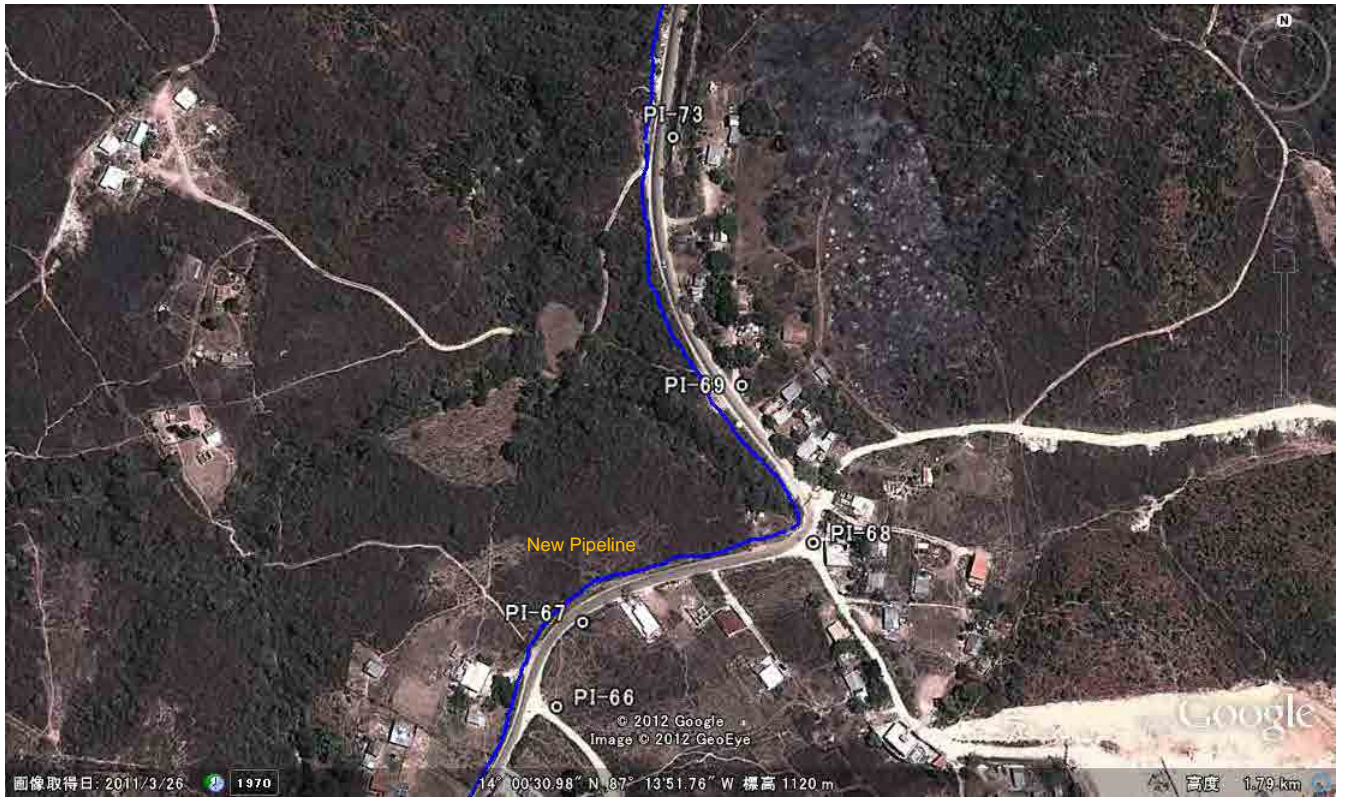

PI73 - PI66

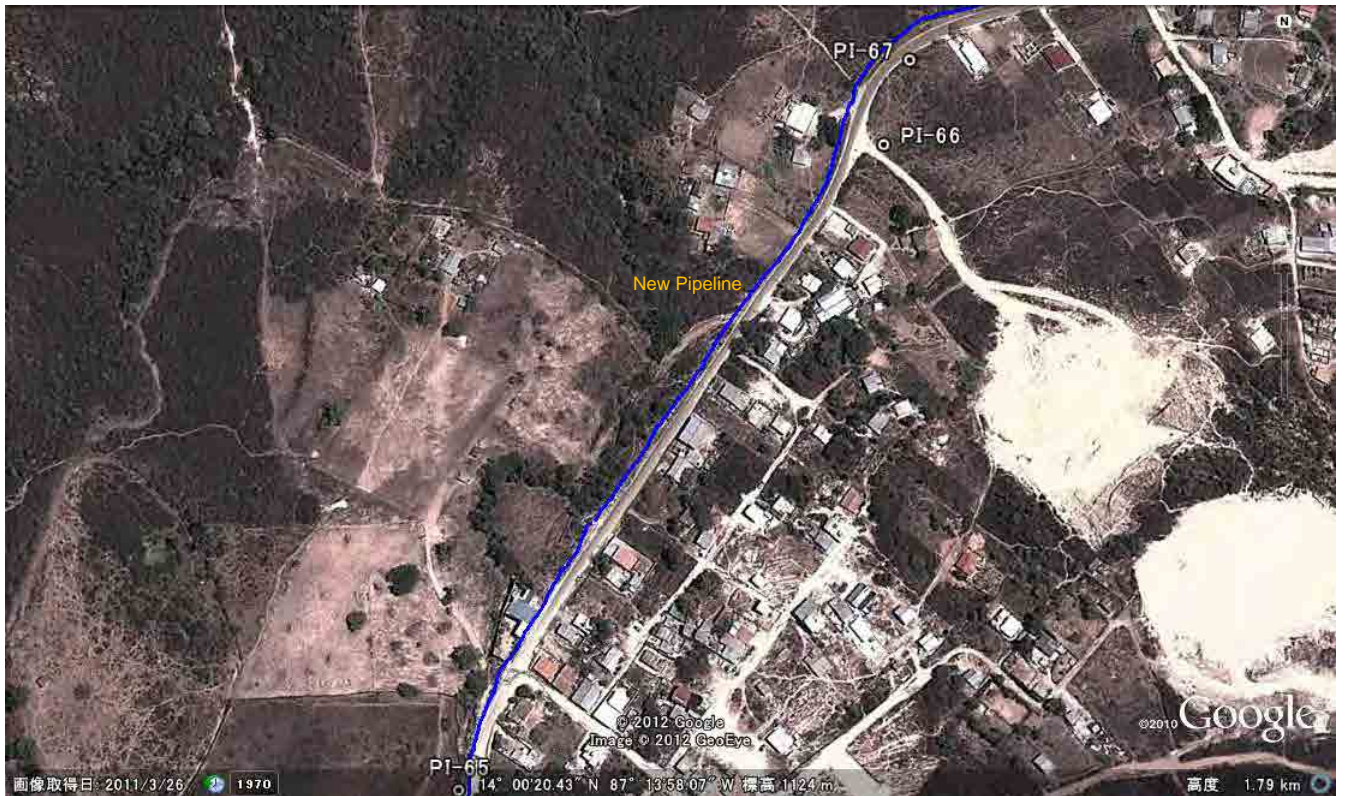

PI67 - PI65

Concepcion Site : New Pipeline Route

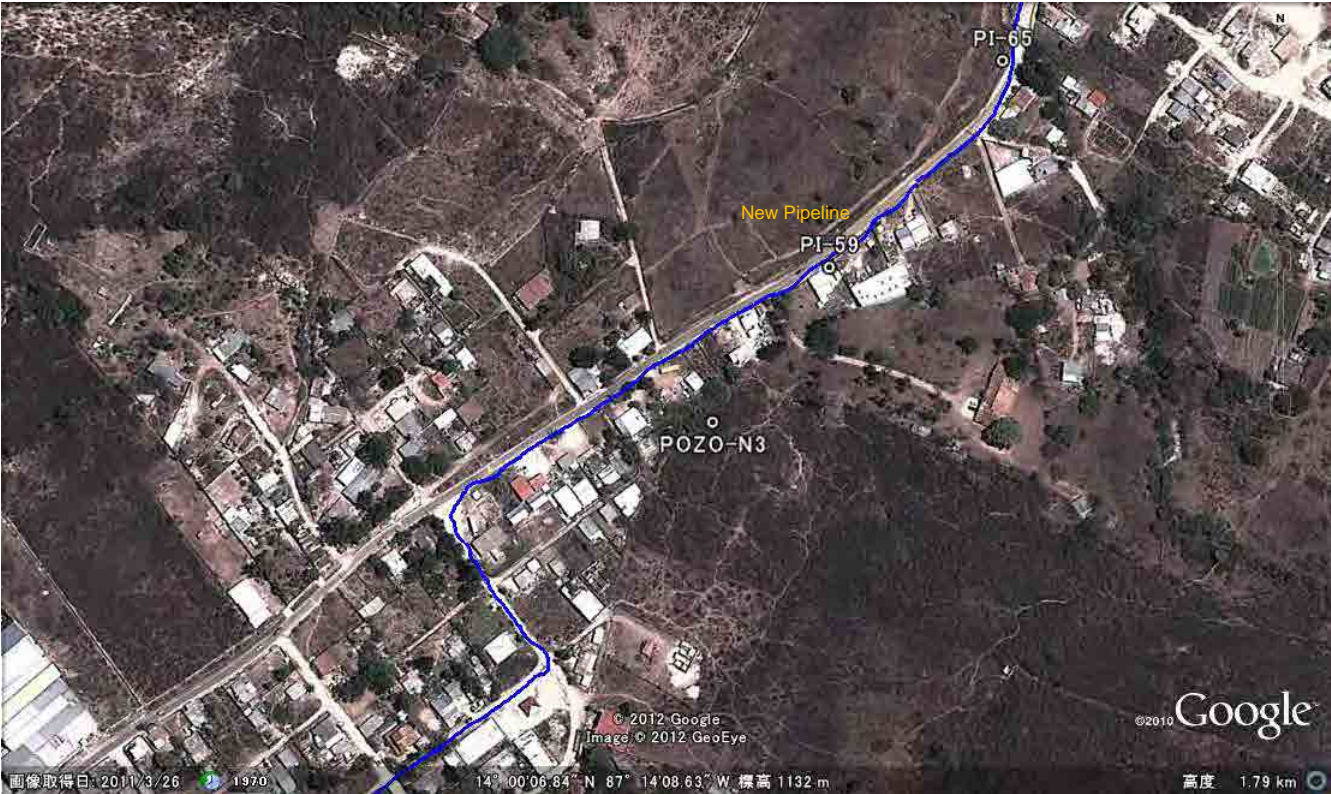

PI65 – Manhole No.3



Manhole No.2 – Manhole No.1



PI-89⇒PI-87



PI-89⇒PI-87⇒PI-86



PI-87⇒PI-86



PI-86⇒PI-75



PI-86⇒PI-75



PI-75⇒PI-73



PI-75⇒PI-73



PI-69⇒PI-68

Concepcion Site Pipeline Route



PI-69⇒PI-68



PI-68⇒PI-67



PI-67⇒PI-66



PI-67⇒PI-66⇒PI-65

3



PI-66⇒PI-65



PI-66⇒PI-65



PI-66⇒PI-65⇒PI-59



PI-65⇒PI-59

Concepcion Site Pipeline Route

3.2 Picacho Site

The essential data for power generation plan such as discharge data and effective head is not reliable.

The following points shall be decided immediately for further study.

- Design and maximum distribution water volume of L22 system
- Future distribution water plan of L22 system and forecast
- Set pressure value of pressure reducing valve

The Picacho site has difficulties for power generation plan due to very small amounts of water in addition to pressure degradation and aeration into the pipe.

The present valve operation for L22 pipeline at the treatment plant is to be changed and water regulating valve installed at the downstream of the turbine is to be operated for water distribution. Valve operation at each distribution pond is not changed. To avoid cavitation of the turbine, the minimum power discharge is required.

Power Generation Plan of Picacho Site

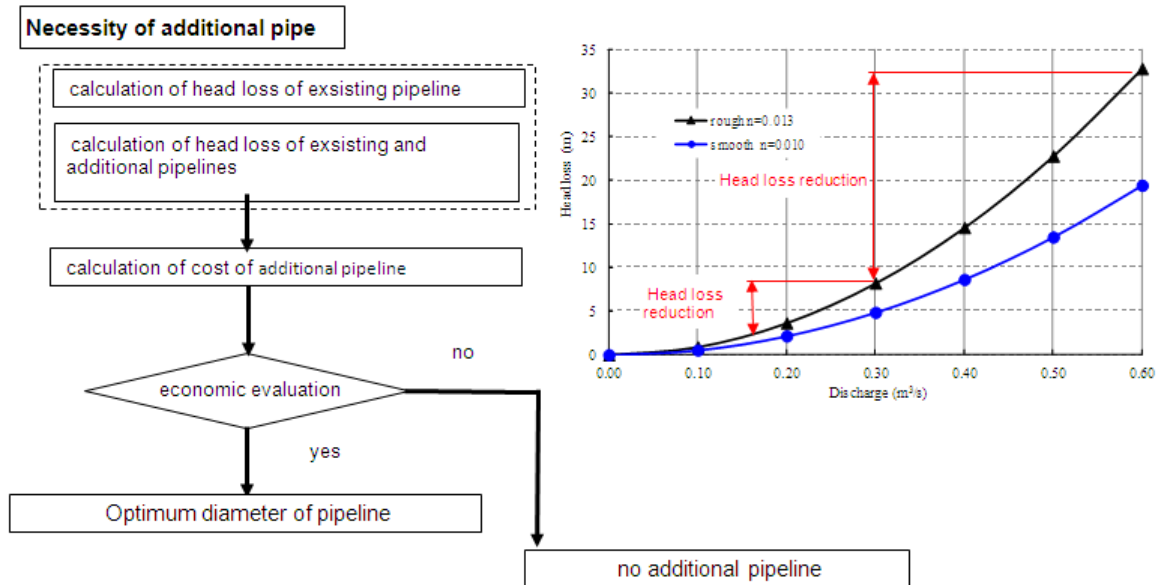

Study on Necessity of Additional Pipe

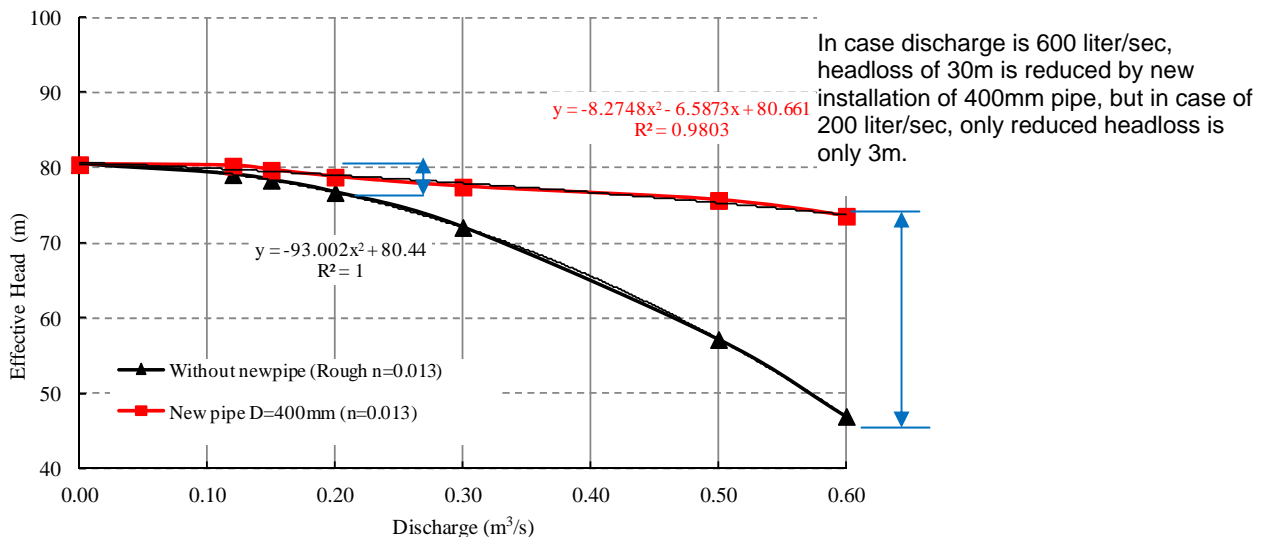

Calculated Effective Head of L22 Pipeline with new pipe for Various Discharges

Water Distribution Pattern of L22 Pipeline in the rainy season (September 2012)

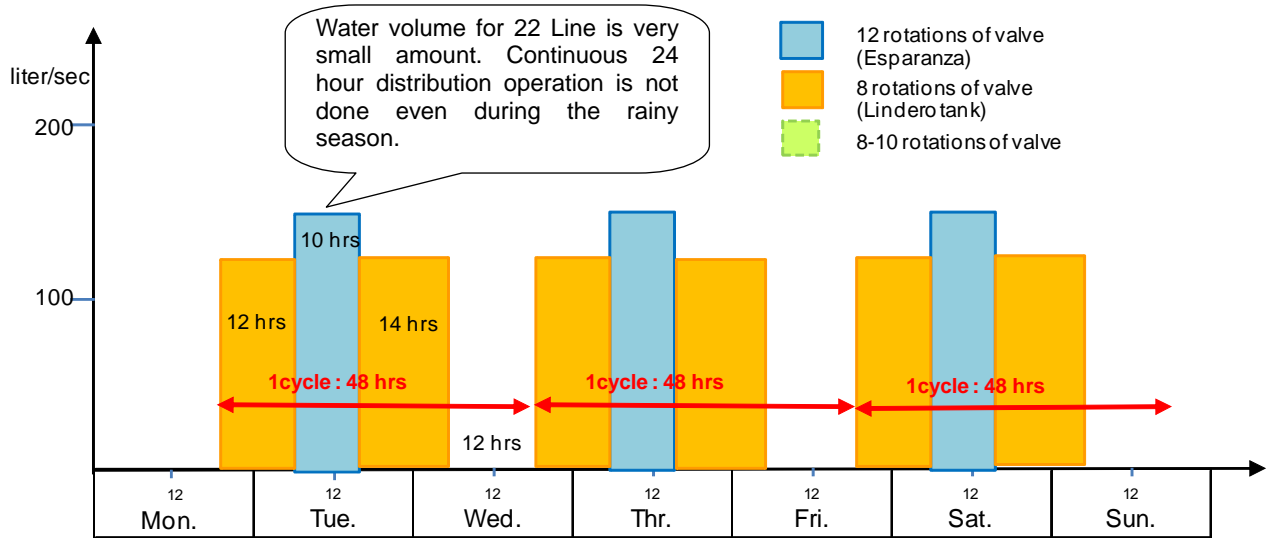

Water Distribution Pattern of L22 Pipeline in the dry season (March 2012)

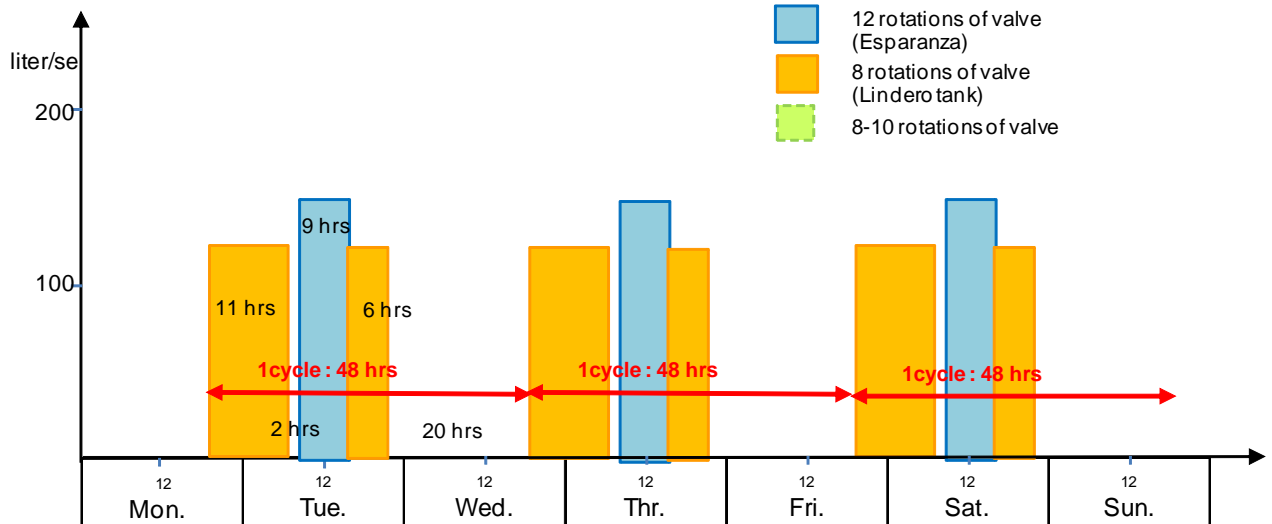

L22 System Water Distribution Typical Pattern in the rainy and dry seasons

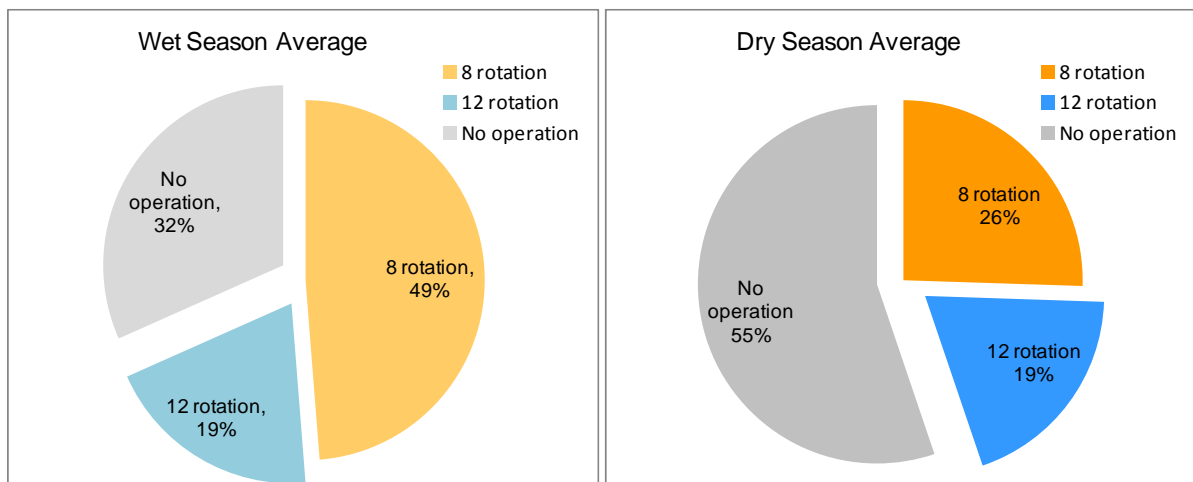

Water Distribution Pattern of L22 Distribution System

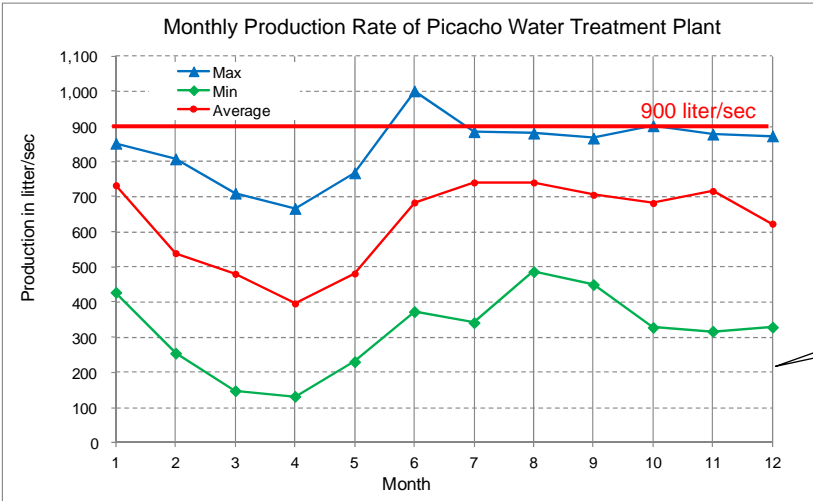
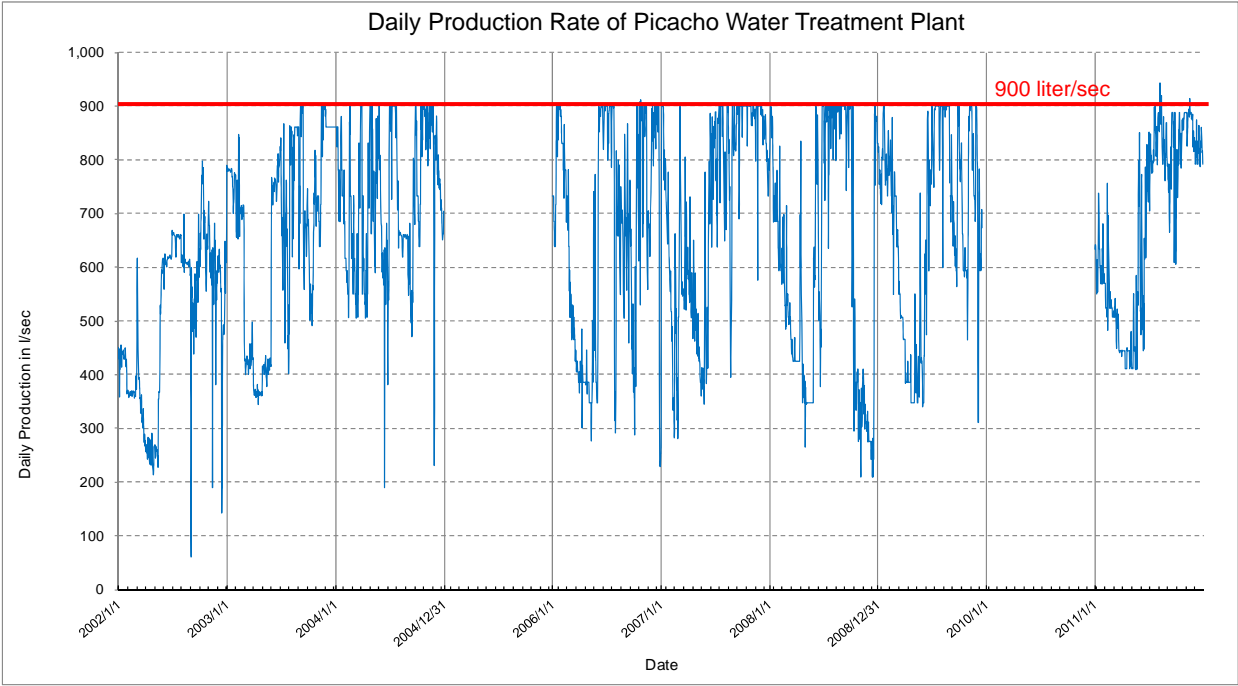

Large fluctuation between water in the rainy season and one in the dry season exists, max. 900 liter/sec and min. 300 liter/sec, it is 3 times.

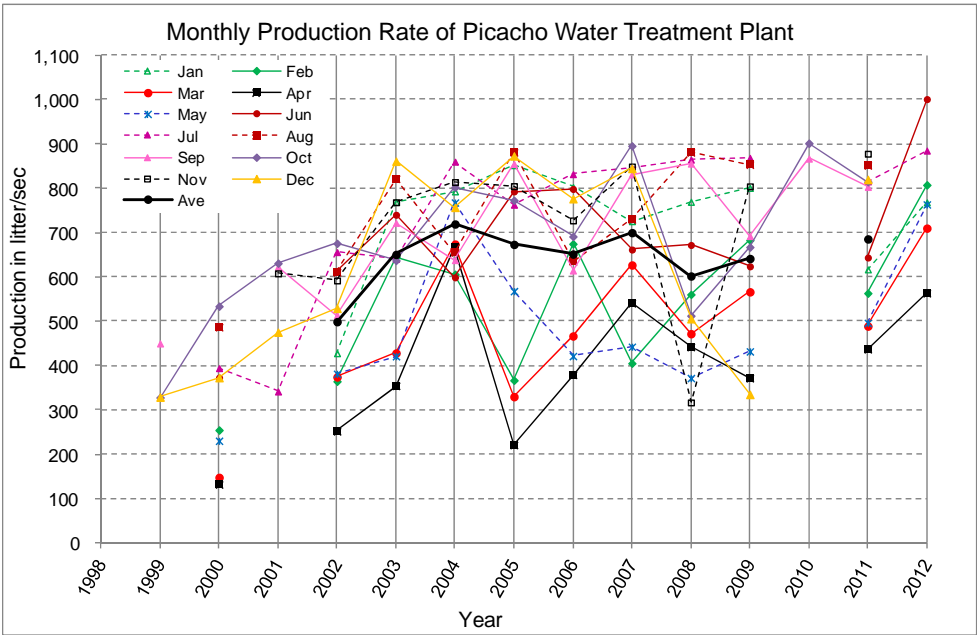

Water Production Rate of Picacho Treatment Plant

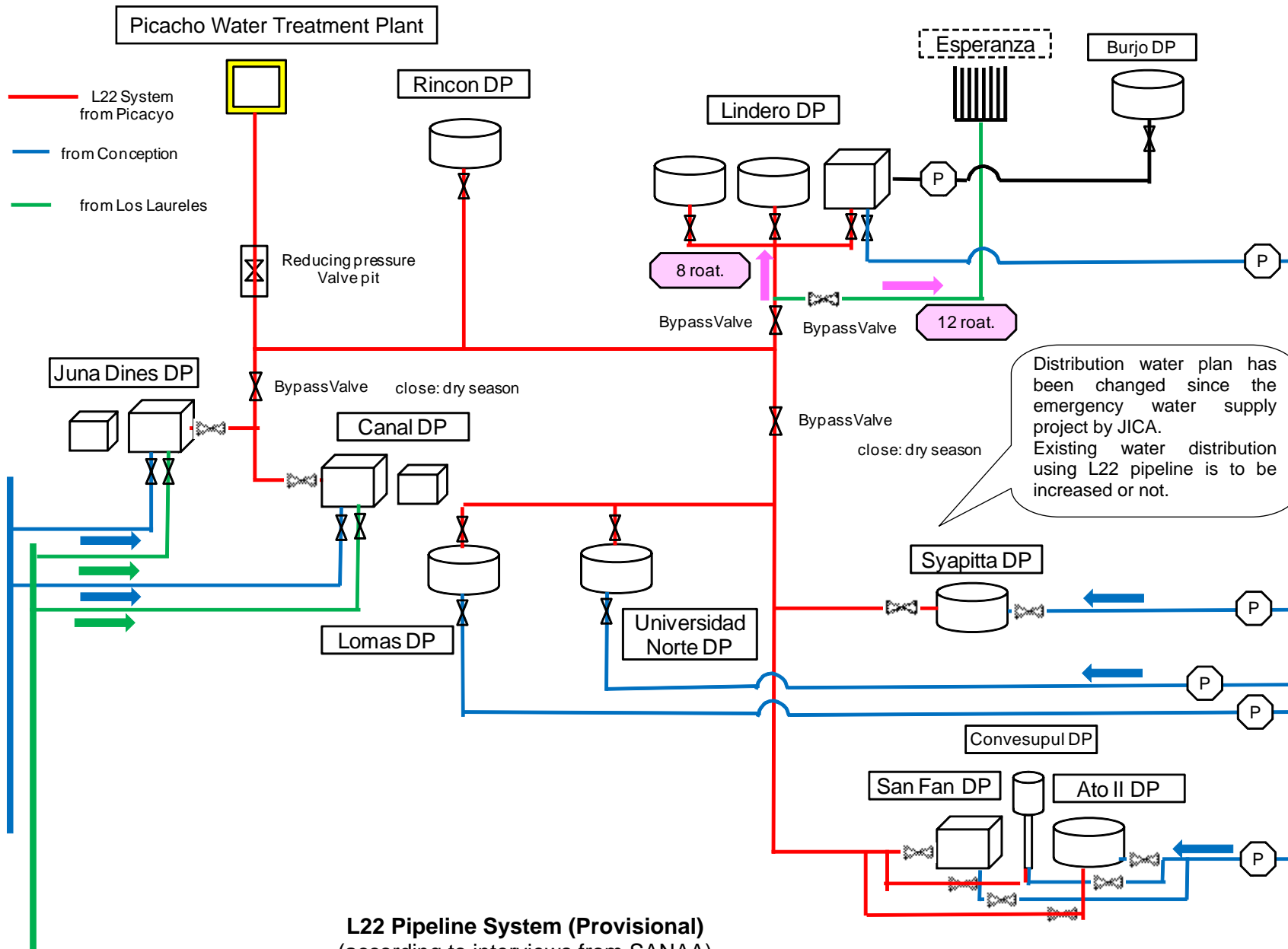

L22 Pipeline System (Provisional)
 (according to interviews from SANAA)

Effective Head Calculation

The pressure in the downstream of reducing valve is to be set to 90m according to JICA Study results. The high pressure will act on downstream pipes located in lower elevation. The location of powerhouse is around 10m higher than the existing pit.

Picacho Water Treatment Plant

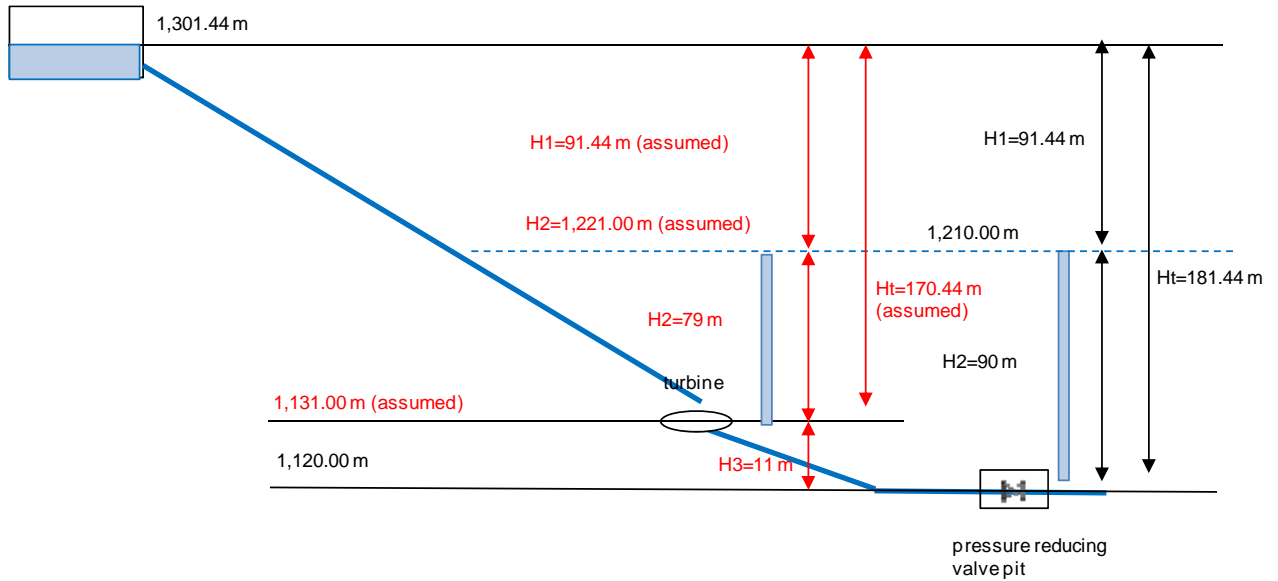

Turbine Discharge (Q_{max})	Gross Head (H_g)	Effective Head (H_e)
0.12 m ³ /s	91.44 m	90.29 m
0.15 m ³ /s	91.44 m	89.64 m
0.30 m ³ /s	91.44 m	84.22 m

* 10% increase of total friction loss, Manning roughness coefficient: $n=0.014$

Discharge Measurement at L22 System and Pressure Test at Pressure Reducing Valve

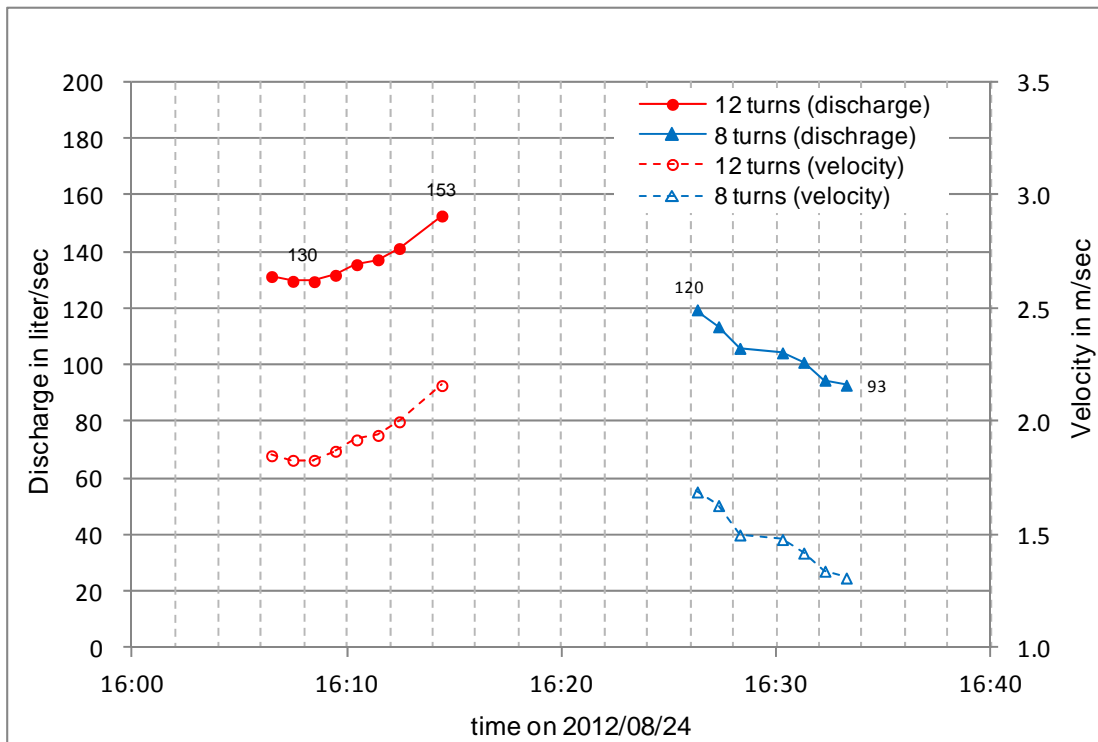

Discharge measurement results

Unit: liter/sec

Date		mean	max	min	remarks
2012/08/24	12 turns	136	153	130	Lindero distribution reservoir
	8 turns	105	120	93	
2012/08/29	8 turns	120			L22 pipeline upstream the valve pit
	20 turns		480	405	

Pressure measurement results

Unit: bar

Date		upstream	downstream	remarks
2012/08/29	8 turns	4.827 (70 psi)	4.068 (59 psi)	L22 pipeline upstream the valve pit
	15 turns	6.843	6.843	
	20 turns	15.393	15.393	

*: It is judged that pressure reducing valve must not be functioned properly.



Picacho Powerhouse Site

PREPARATORY SURVEY FOR THE PROJECT OF MICRO-HYDROELECTRIC POWER GENERATION IN METROPOLITAN AREA OF TEGUCIGALPA IN THE REPUBLIC OF HONDURAS

December, 2012

NEWJEC Inc.
JAPAN TECHNO Co., Ltd.

Location Map of Concepcion & Picacho Hydroelectric Power Plants



General Plan & Profile of Concepcion Hydroelectric Power Plant

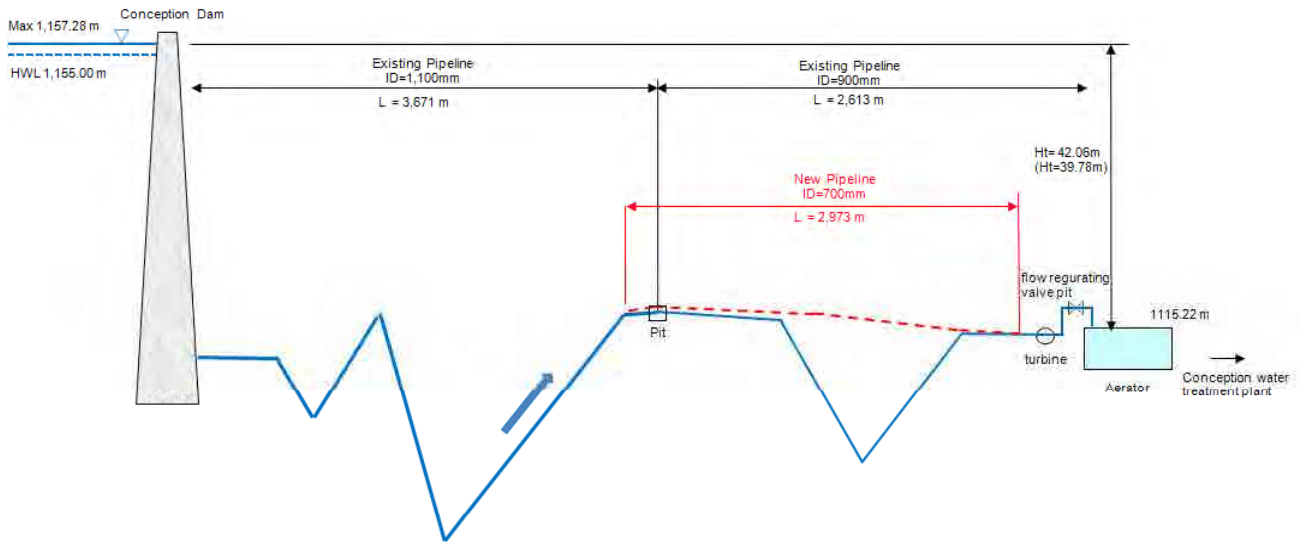

item	value
Max. Power discharge	1.5 m ³ /sec
Max. dam WL	1,157.28m
Tail water WL	1,115.22m
Max. gross head	42.06m
Power discharge at rated capacity	1.2m ³ /sec

item	value
Effective head at rated capacity	26.52m
Rated capacity	273kW
Installed capacity	250kW

3

Daily Dam water level & Intake water of Concepcion Hydroelectric Power Plant

From 2006 to 2011

Dam Water Level: Max 1,157.3m – Min 1,137.8m Ave. 1,151.0m

Dam intake water : Max 1,550 – Min 866.7 liter/sec Ave 1,253.1 liter/sec

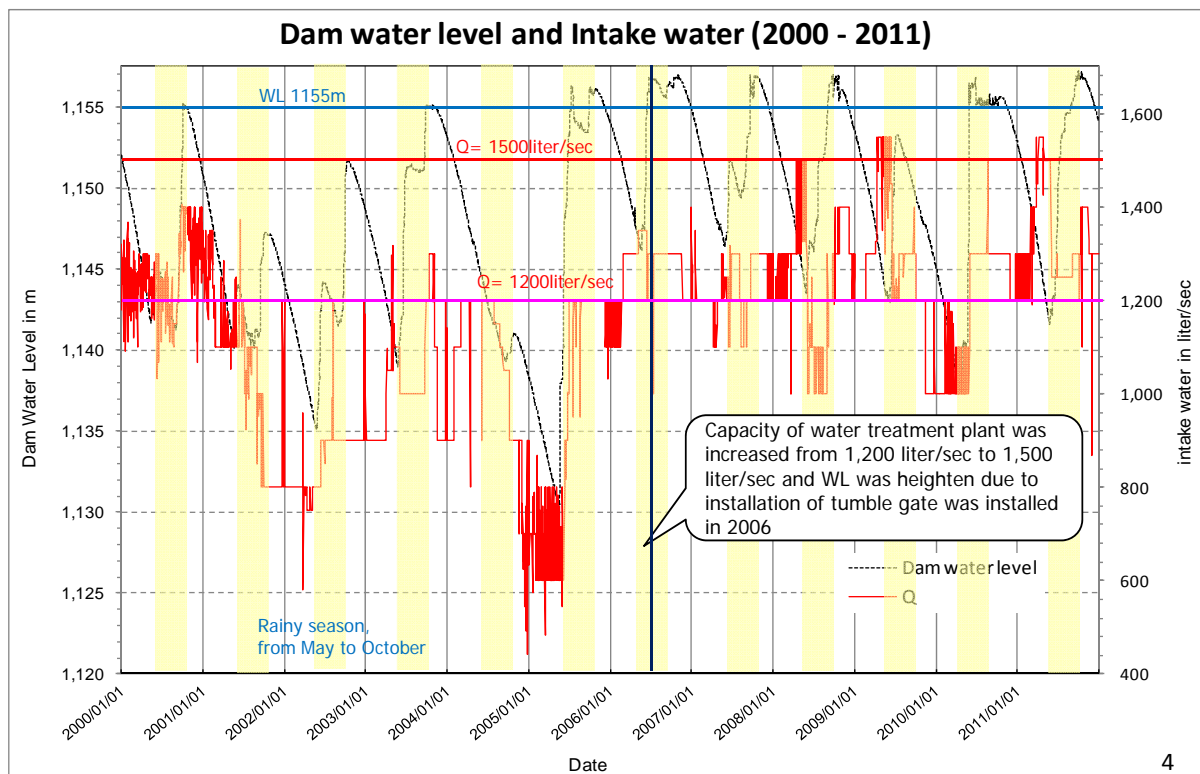

4

Duration Curve of Intake water of Concepcion Hydroelectric Power Plant

To utilize Intake water as much as possible for power generation

Max Intake water = Max Power discharge (Q_{pmax}) = 1,500 liter/sec

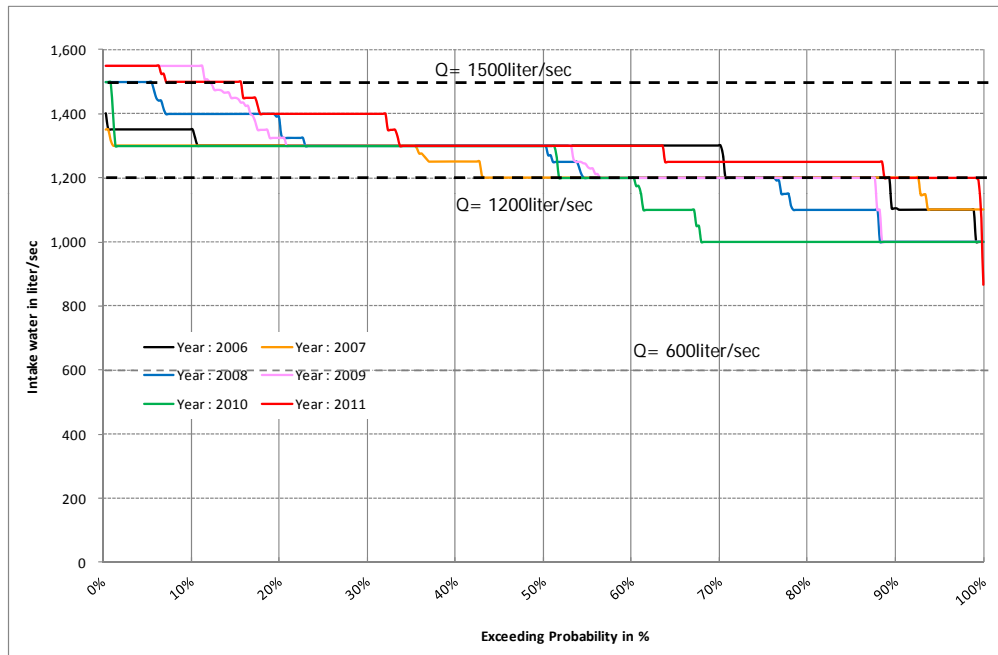

5

Head loss and Effective head of Concepcion Hydroelectric Power Plant

Head loss of Existing steel pipe

Intake water m^3/sec	Friction Head loss (m)				Total head loss
	ID 1,100mm section		ID 900mm section		
	L=3,671m		L=2,613 m		
	Sub-total	Per 100m	Sub-total	Per 100m	
0.4	1.10	0.030	2.07	0.079	3.17
0.8	3.95	0.108	7.47	0.286	11.42
1.0	5.97	0.163	11.29	0.432	17.26
1.2	8.36	0.228	15.82	0.605	24.18
1.3	9.70	0.264	18.34	0.702	28.04
1.5	12.64	0.344	23.90	0.915	36.54

Existing steel pipe ID 1,100mm Existing steel pipe ID 900mm

Large head loss occurs in ID900mm section, so new pipe shall be installed in ID 900mm section.

Total Head loss after installation of new ID 700mm ductile cast-iron pipe (L=2,973m)

Intake water m^3/sec	Total Head loss (m)	Decreasing head loss due to new pipe (m)	Effective Head at Max WL (m)
0.0	0.00	-	42.06
0.4	2.01	1.16	40.05
0.8	6.88	4.54	35.18
1.0	10.38	6.88	31.68
1.2	14.60	9.58	27.46
1.3	16.98	11.06	25.08
1.5	22.27	14.27	19.79

To increase electric energy due to installation of new ductile pipe.

New ductile cast-iron pipe ID 700mm

(Reference: Hazen-Williams formula existing steel pipe C=90, new ductile pipe C=110)

6

Economic Parameters for Optimization of Pipe Diameter at Concepcion Hydroelectric Power Plant

Optimum diameter of new ductile pipe is ID 700mm because of the lowest unit construction cost per kWh (material cost + installation cost)

Economic parameter	Period for calculation	500mm	600mm	700mm
Unit Pipe Construction Cost per kWh yen/kWh	2006 – 2011 Average	179	168	163
	2000 – 2011 Average	206	186	182
B-C a million yen/year	2006 – 2011 Average	3.98	5.52	6.85
	2000 – 2011 Average	3.10	4.66	5.71
B/C	2006 – 2011 Average	2.45	2.60	2.68
	2000 – 2011 Average	1.95	2.12	2.14

B: Annual income of electricity selling (0.13695 US\$/kWh)

C: Annual capitation cost of ductile pipe installation in case of 40 year life time of the pipe (51,000US\$/year)

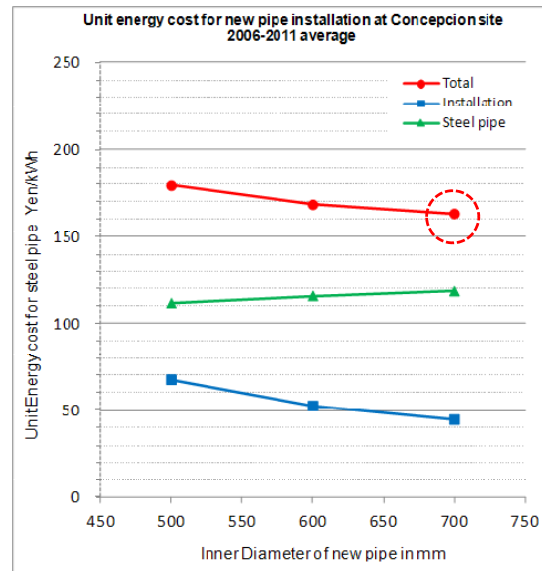
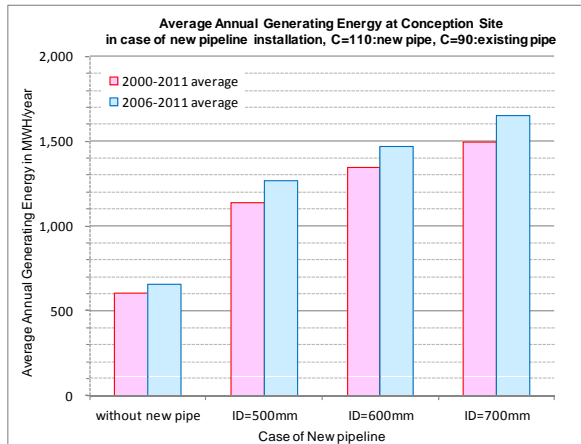

7

Annual Electric Energy of Concepcion Hydroelectric Power Plant

Mean annual electric energy with new installation of ID 700 mm ductile pipe is 1.650 GWh/year (Assumed income of selling electricity : 230,000US\$/year = 18 million yen/year (0.13695 US\$/kWh))

Period For calculation		Mean Annual Electric Energy	Maximum Annual Electric Energy	Minimum Annual Electric Energy
2006 – 2011	GWh/year	1.650	1.910	1.349
	PF	75%	87%	62%
2000 - 2011	GWh/year	1.495	1.910	1.201
	PF	68%	87%	55%

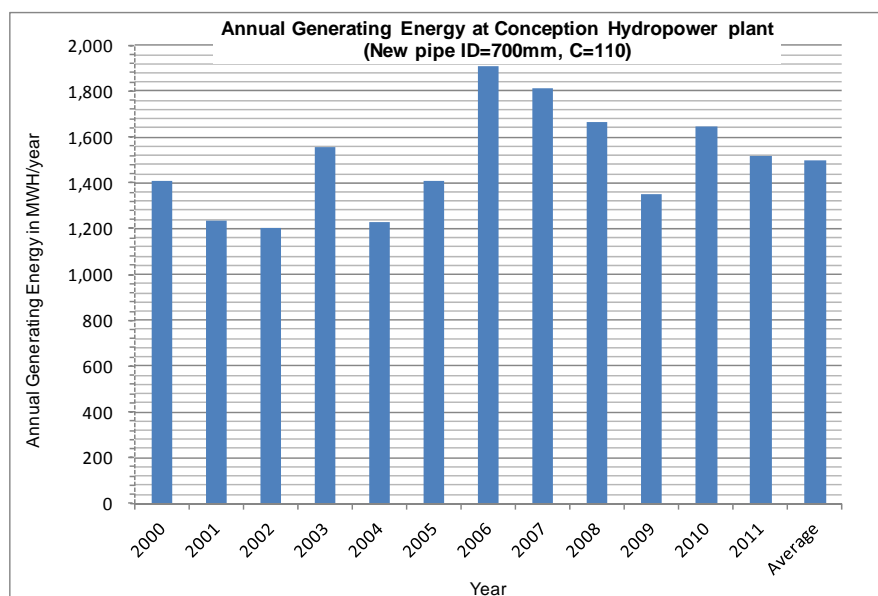

8

Concepcion Hydroelectric Power Plant

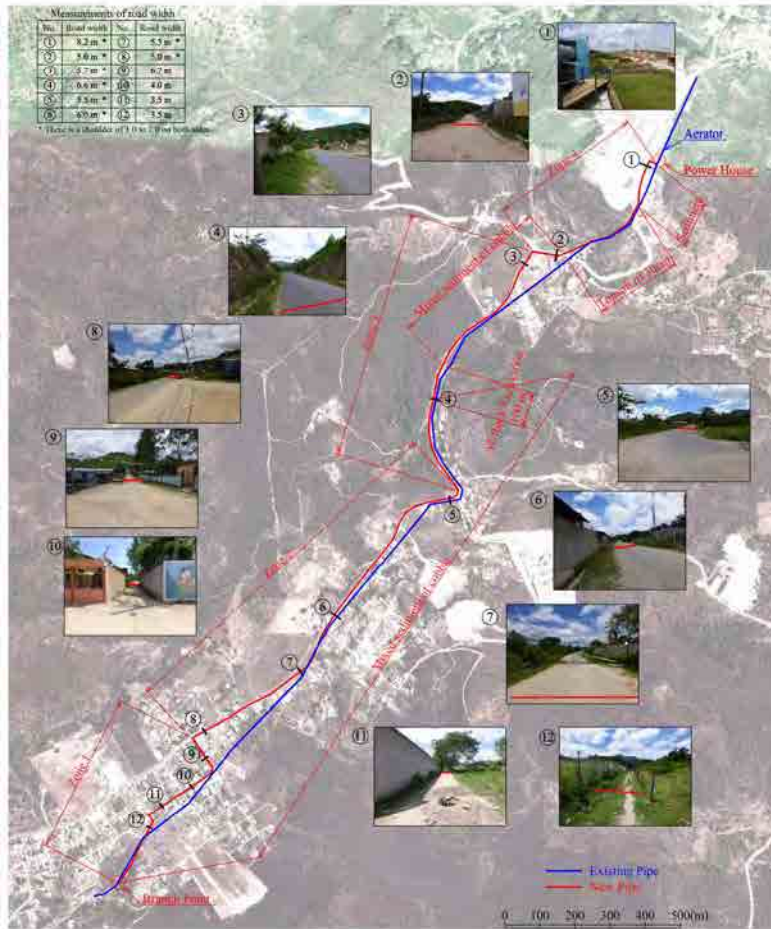

New pipeline is to be installed under ground along the existing road.

Kind : Ductile cast-iron pipe

Diameter : 700 mm

Total length : 2,973m

9

Concepcion Hydroelectric Power Plant



10

Concepcion Hydroelectric Power Plant



11

Concepcion Hydroelectric Power Plant

Section a-a

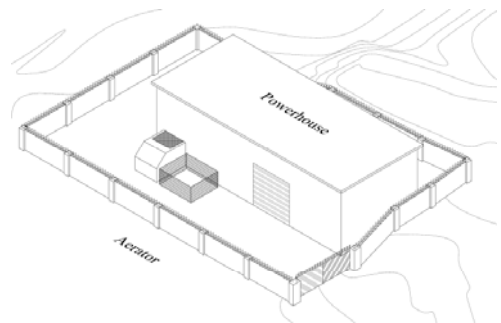
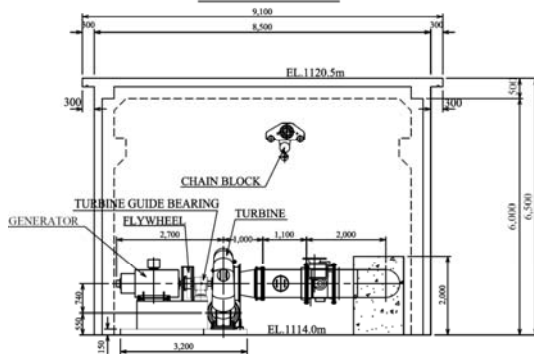

Section b-b

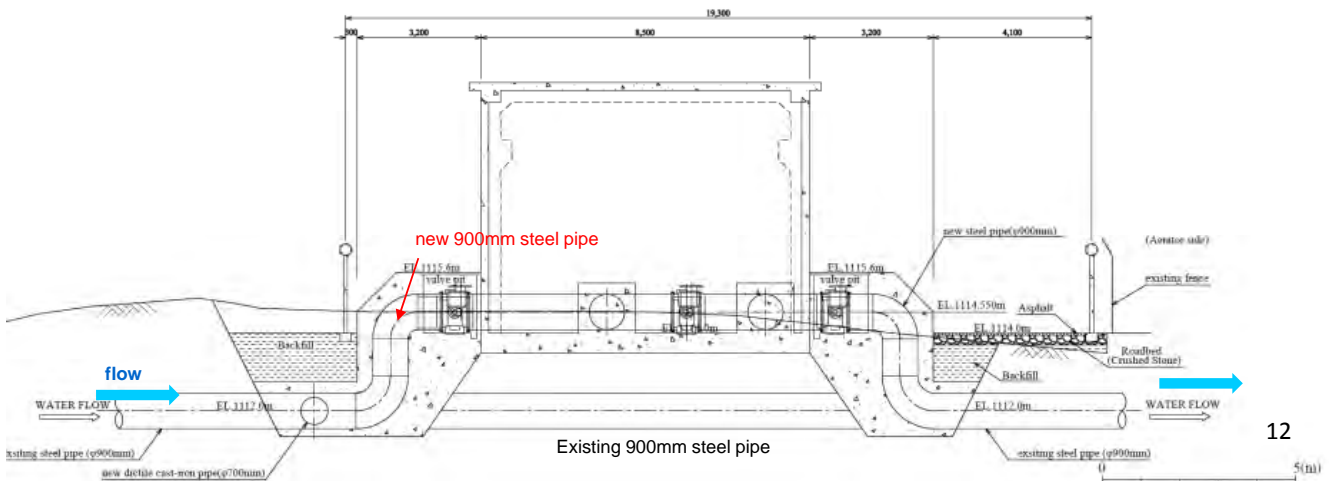

12

General Profile of Picacho Hydroelectric Power Plant

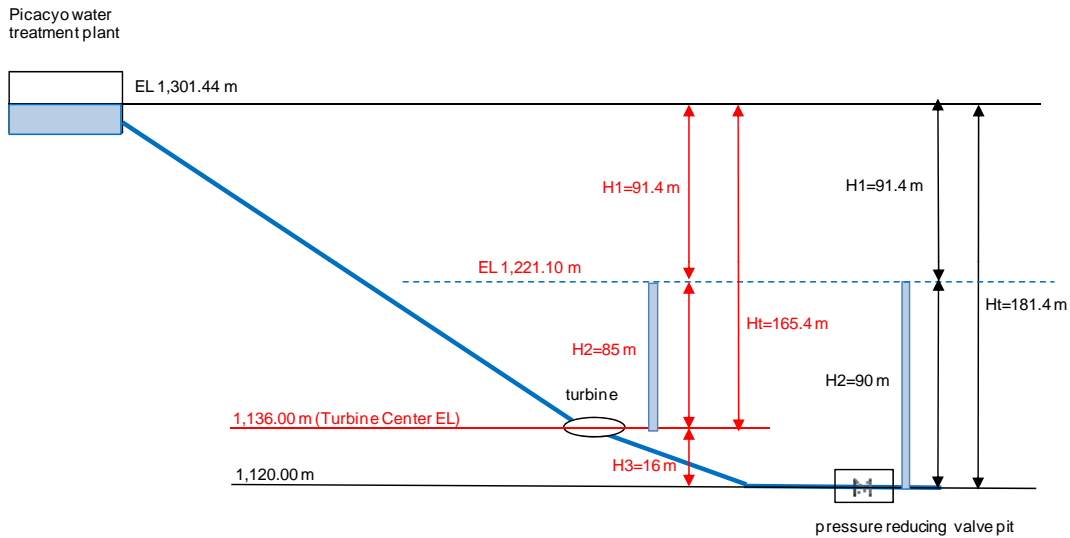

item	value
Max. Power discharge	0.3 m ³ /sec
Picacho water treatment plant WL	1,301.44m
Tail water WL	1,210.00m
Max. gross head	91.44m
Effective head at rated capacity	86.16m
Rated capacity	204kW
Installed capacity	180kW

to distribute 120liter/sec water to Lindero pond and distribute 150liter/sec to Esperanza community (actual measurement).
Max design distribution water 225 liter/sec

Water Distribution Operation Pattern of L22 pipeline of Picacho Water Treatment Pplant

Water Distribution Pattern of L22 in the wet season (September 2012)

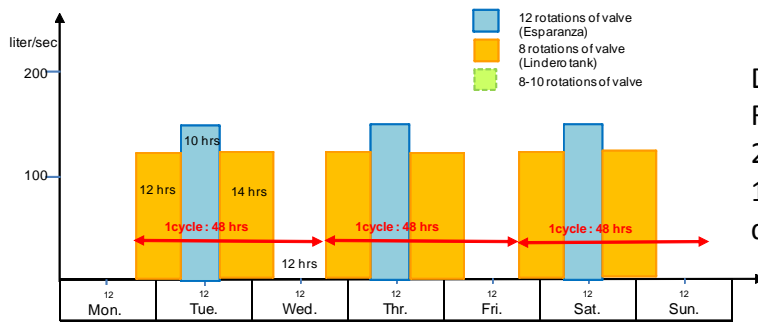

Distribution operation pattern in the Rainy season :
26 hour-operation with 120liter/sec, 10 hour-operation with 150liter/sec during 48 hours (total 75% operation)

Water Distribution Pattern of L22 in the dry season (March 2012)

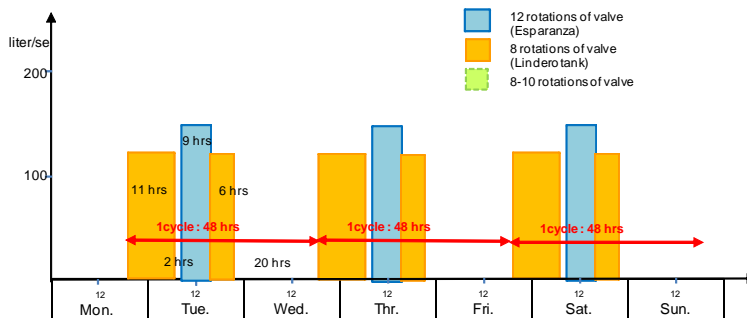

Distribution operation pattern in the Dry season :
17 hour-operation with 120liter/sec, 9 hour-operation with 150liter/sec during 48 hours (total 54% operation)

Annual Electric Energy of Picacho Hydroelectric Power Plant

Annual electric energy is 0.52GWh/year under existing water distribution condition, however, considering max design distribution water of 225 liter/sec for L22 pipeline , more energy can be generated under effective water distribution schedule.

(Assumed income of selling electricity : 71,000US\$/year = 5.6 million yen/year (0.13695 US\$/kWh))

Picacho Hydroelectric Power Plant



15

Picacho Hydroelectric Power Plant

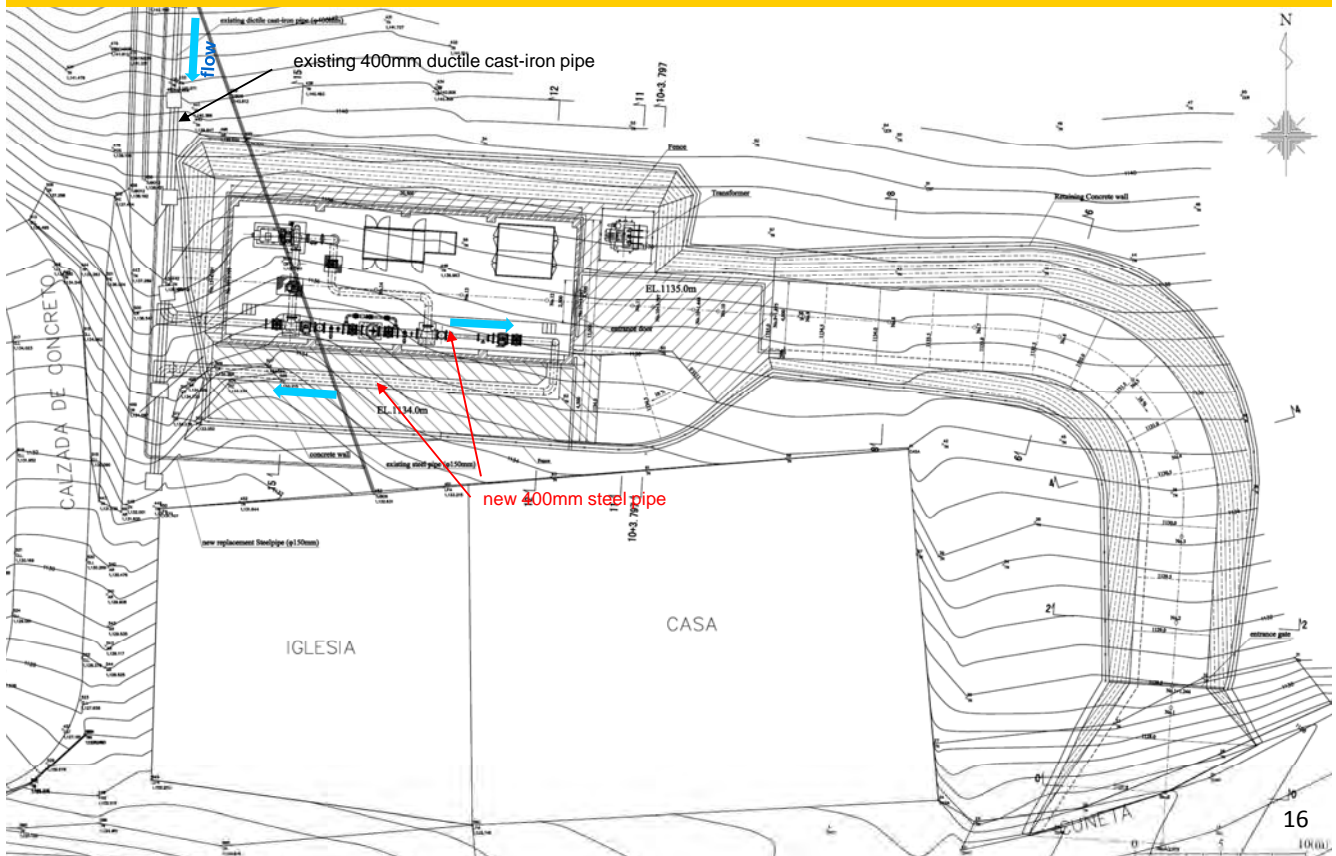

16

Picacho Hydroelectric Power Plant

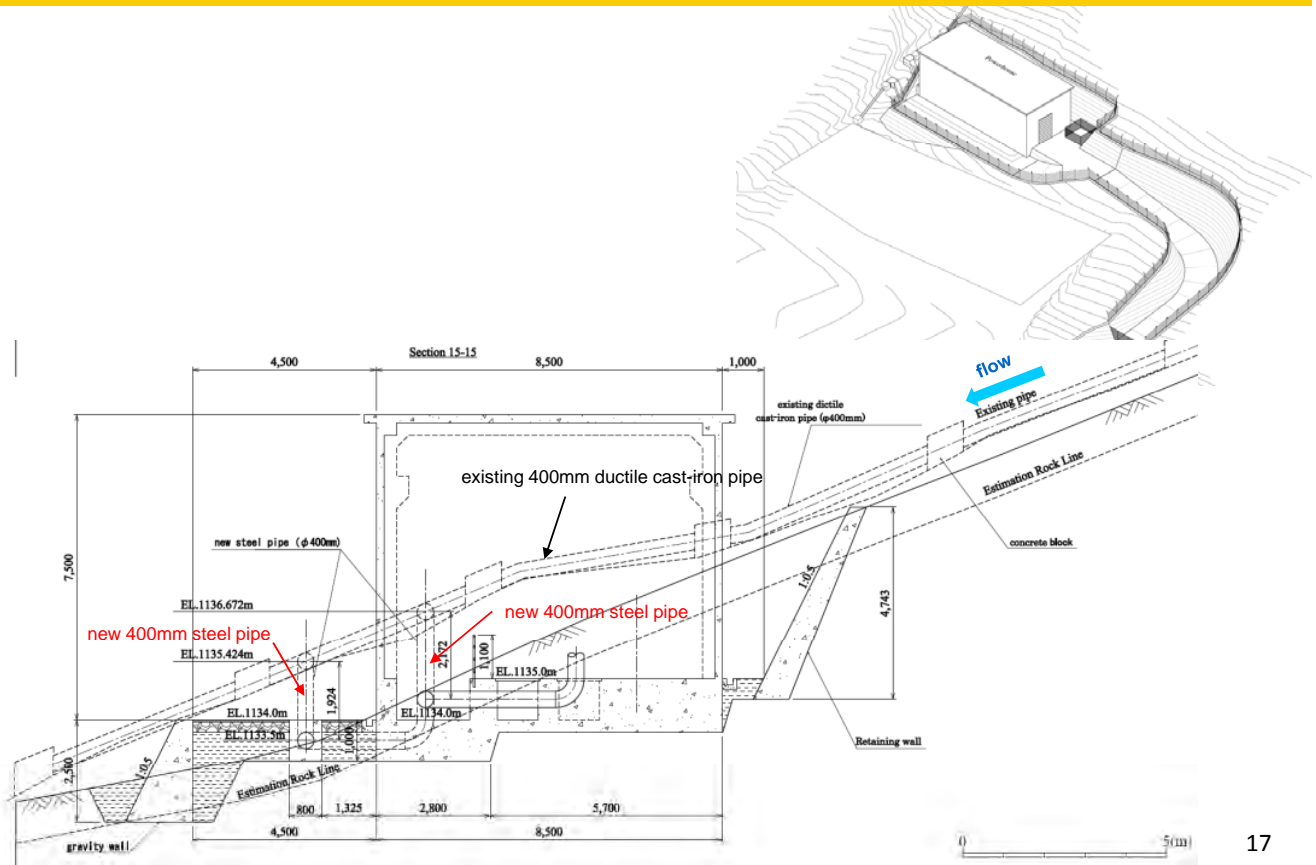

Concepcion Hydroelectric Power Plant (250kW)

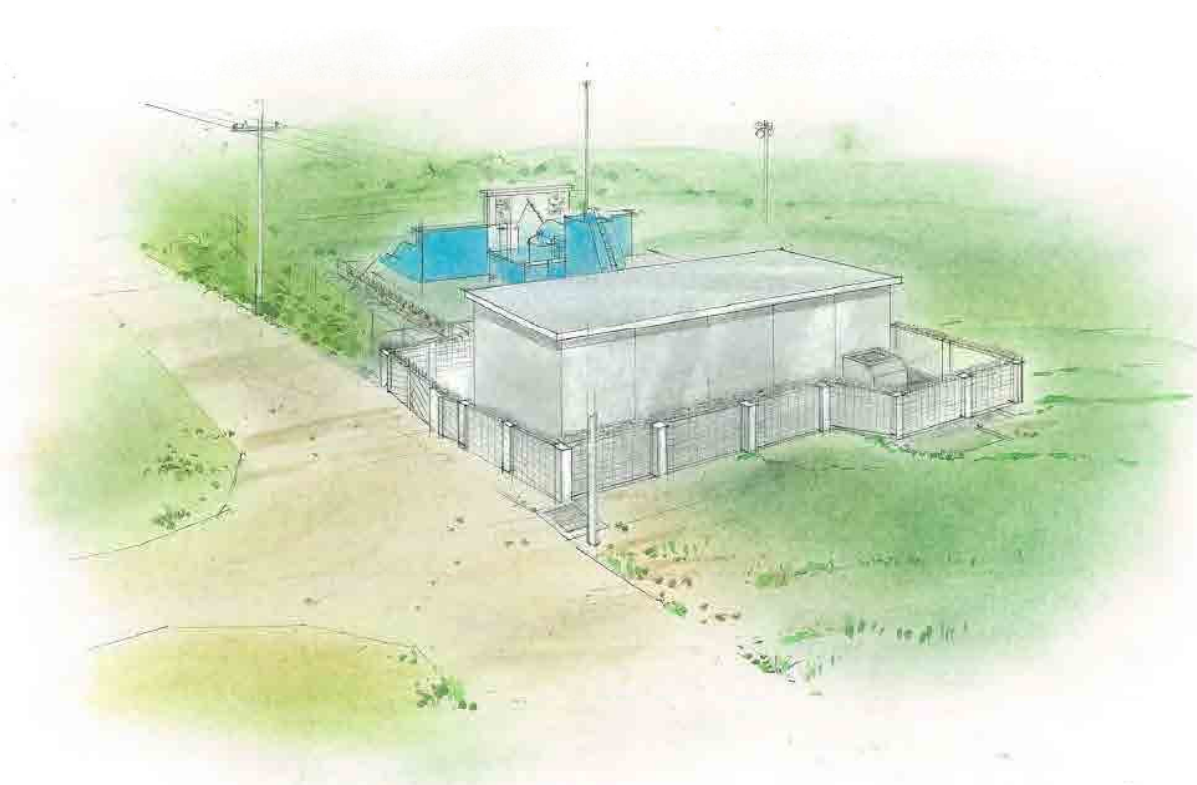

Picacho Hydroelectric Power Plant (180 kW)

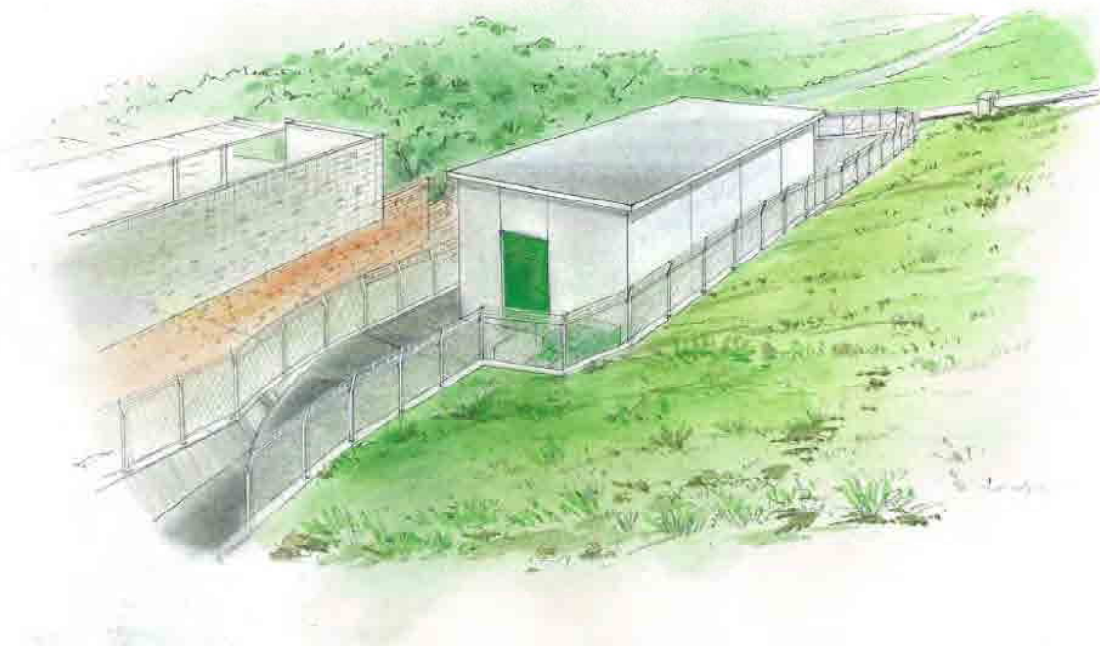

19

Operation & Maintenance of Concepcion & Picacho Hydroelectric Power Plants

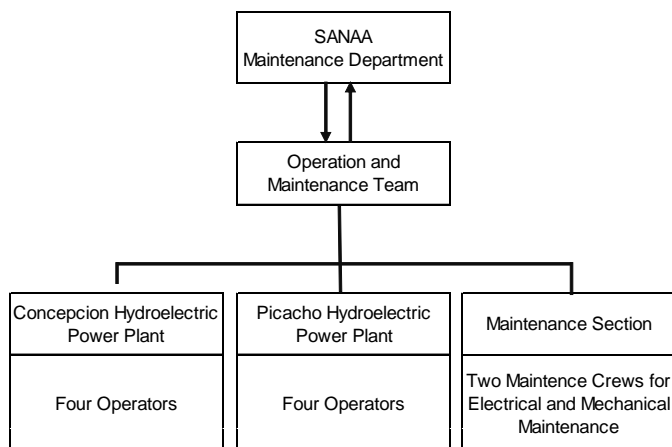

Periodic Inspection and Deterioration Diagnosis

Daily Patrol Inspection		Periodic Inspection and Deterioration Diagnosis		
Facility	Frequency	Facility	Item	Frequency
Turbine, Generator and Electrical Equipment	one time/day	Turbine, Generator and Electrical Equipment	Periodic Inspection	one time/three years
			Deterioration Diagnosis	
			Detailed Inspection	an abnormality is observed

Overhaul of Turbine and Valves

Item	Frequency
Overhaul after Operation	One year after operation
Overhaul	a time/ten years

20

TURBINE, GENERATOR AND ELECTRICAL EQUIPMENT

21

Concepcion Hydroelectric Power Plant (250kW)

22

Concepcion Hydroelectric Power Plant

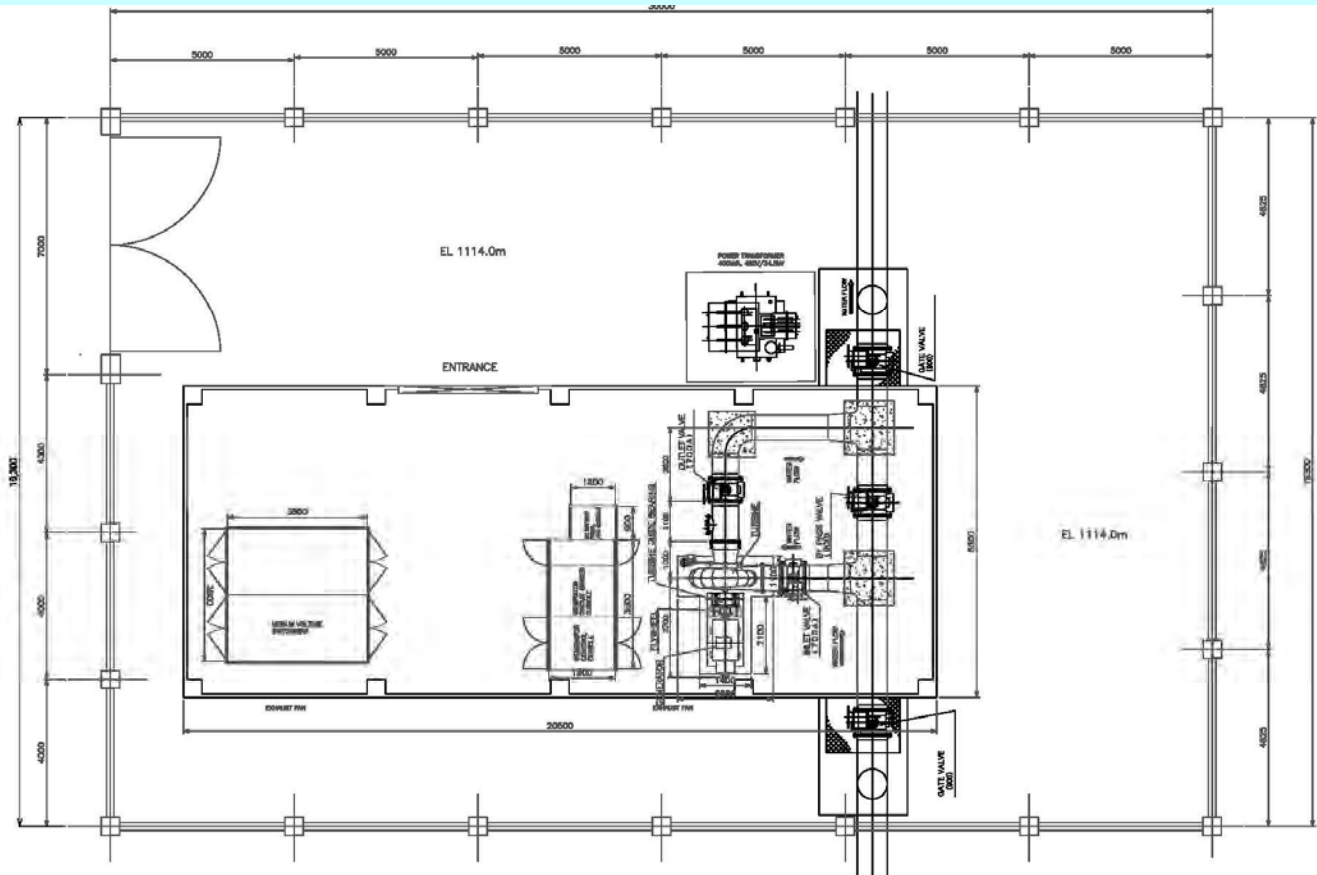

23

General Feature of Generating Equipment (Concepcion Site)

1. Hydraulic Turbine
 - a. Quantity 1
 - b. Type Horizontal-shaft, Francis
 - c. Power 273kW
 - d. Speed 900rpm
 - e. Discharge 1.50m³/s
 - f. Rated head 27.46m

2. Synchronous Generator
 - a. Quantity 1
 - b. Type Horizontal-shaft, synchronous
 - c. Power 314kVA
 - d. Power factor 80%
 - e. Voltage 480V, three (3) phases
 - f. Speed 900rpm
 - g. Frequency 60Hz

3. Power Transformer
 - a. Quantity 1
 - b. Type Oil immersed, outdoor
 - c. Power 400kVA
 - d. Voltage 0.48/34.5kV, three (3) phases

4. 34.5kV Medium Voltage Switchgear
 - a. Quantity 1

24

Concepcion Hydroelectric Power Plant

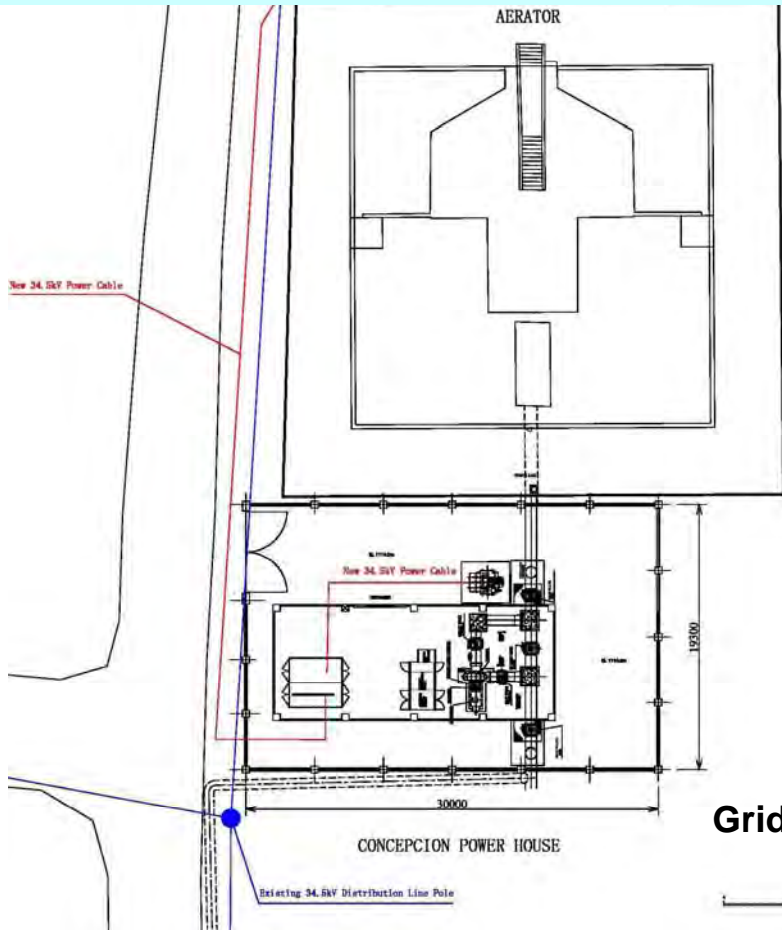

Grid-interconnection Scheme

Concepcion Hydroelectric Power Plant

Operation Scheme (Concepcion Site)

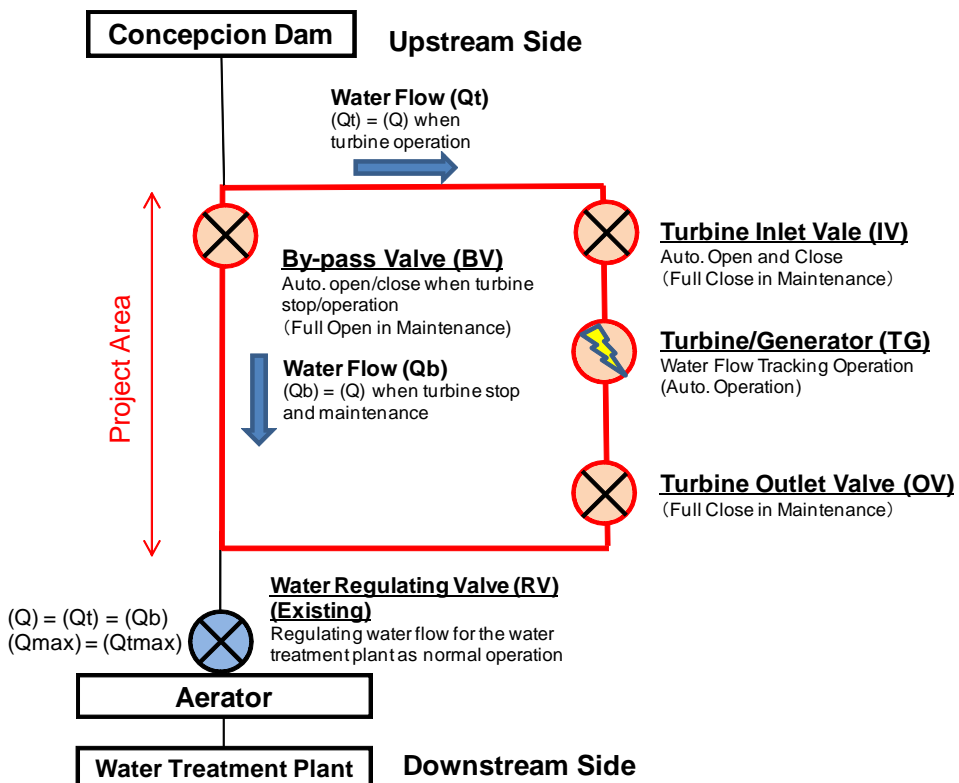

Picacho Hydroelectric Power Plant (180kW)

Picacho Hydroelectric Power Plant

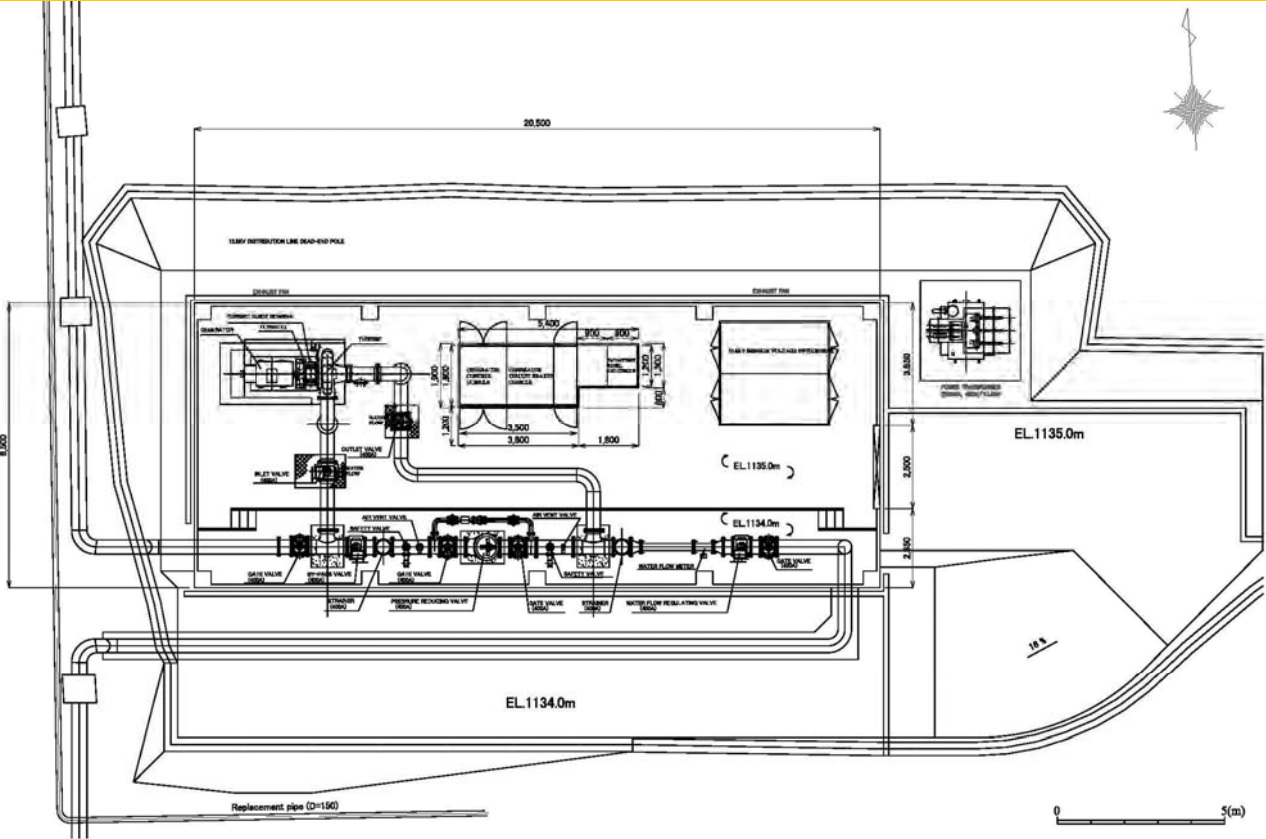

General Feature of Generating Equipment (Picacho Site)

- | | |
|-------------------------------------|-------------------------------|
| 1. Hydraulic Turbine | |
| a. Quantity | 1 |
| b. Type | Horizontal-shaft, Francis |
| c. Power | 204kW |
| d. Speed | 1,200rpm |
| e. Discharge | 0.30m ³ /s |
| f. Rated head | 88.16m |
| 2. Synchronous Generator | |
| a. Quantity | 1 |
| b. Type | Horizontal-shaft, synchronous |
| c. Power | 235kVA |
| d. Power factor | 80% |
| e. Voltage | 480V, three (3) phases |
| f. Speed | 1,200rpm |
| g. Frequency | 60Hz |
| 3. Power Transformer | |
| a. Quantity | 1 |
| b. Type | Oil immersed, outdoor |
| c. Power | 250kVA |
| d. Voltage | 0.48/13.8kV, three (3) phases |
| 4. 13.8kV Medium Voltage Switchgear | |
| a. Quantity | 1 |

29

Picacho Hydroelectric Power Plant

Grid-interconnection Scheme

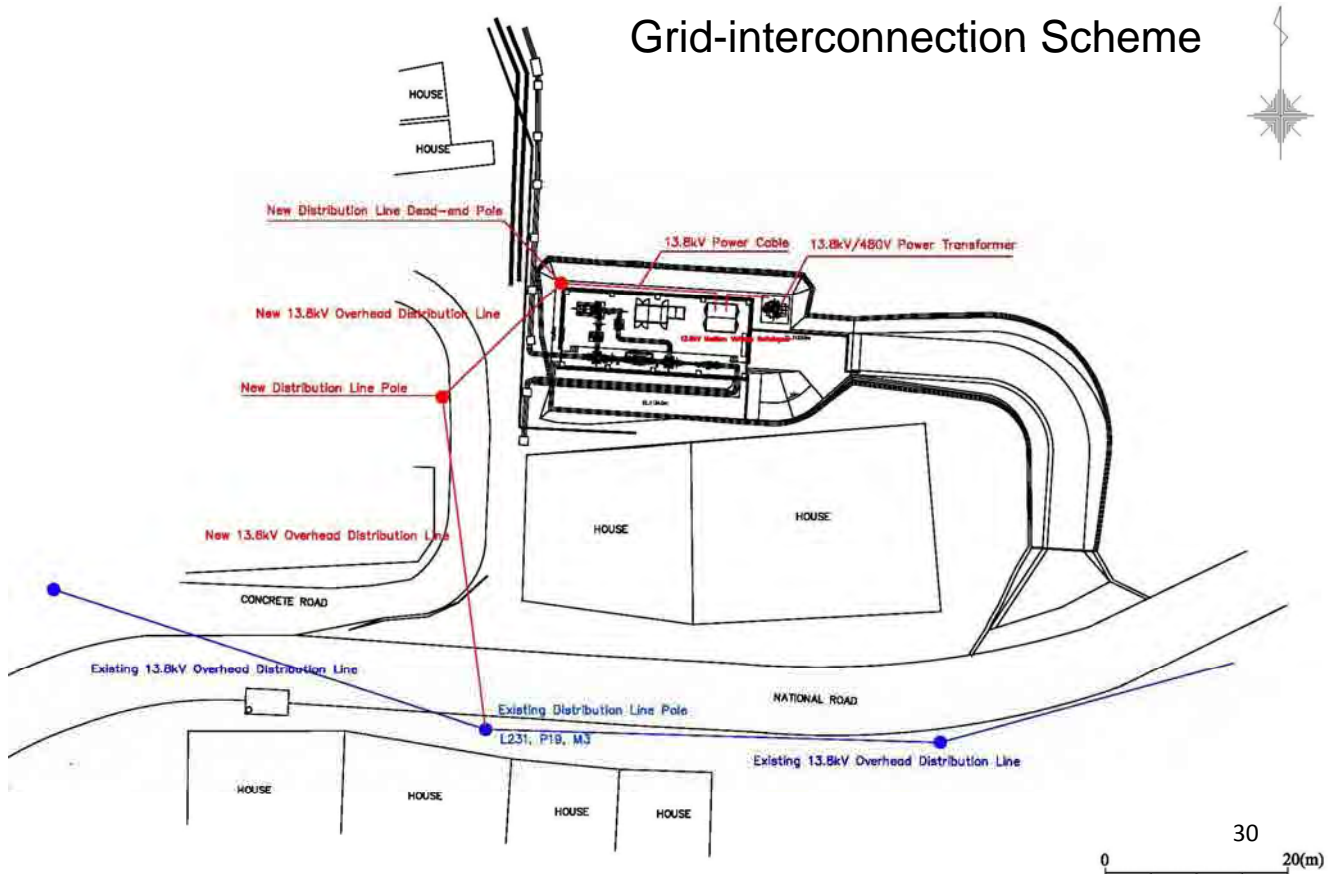

Picacho Hydroelectric Power Plant

Operation Scheme (Picacho Site)

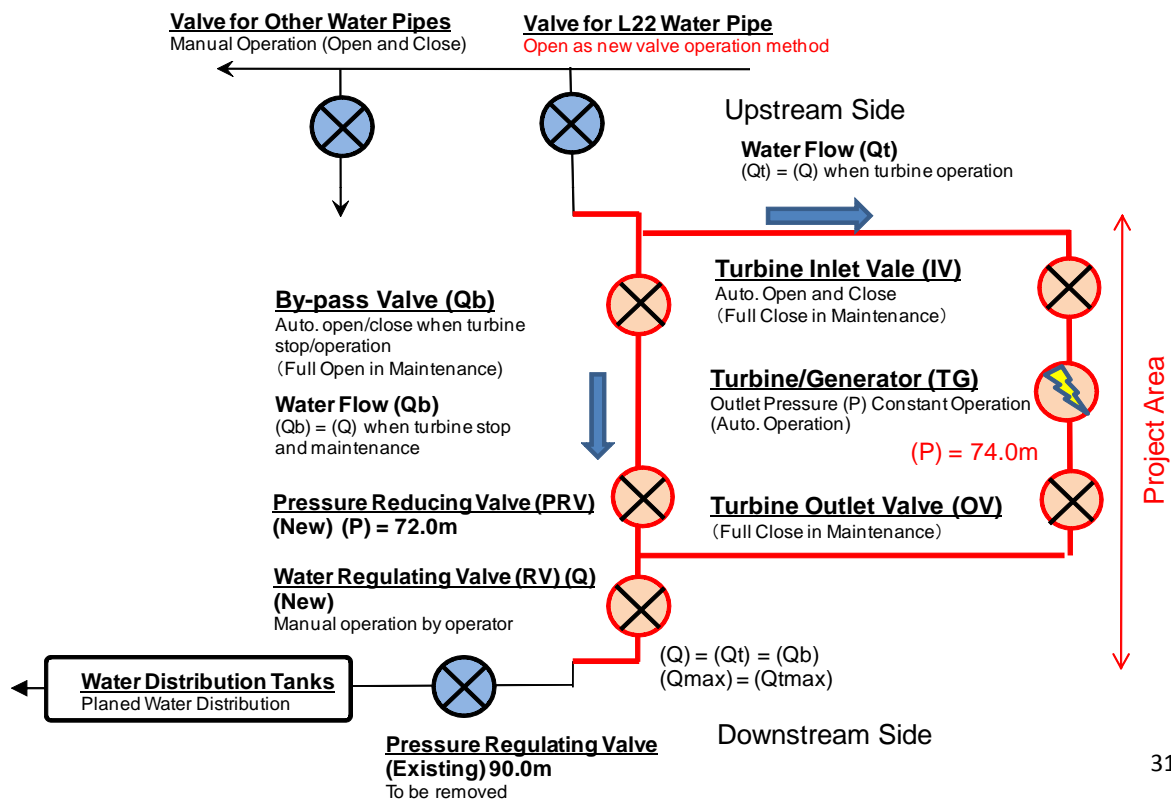

31

Equipment & Material Procurement

The country of origin for the equipment being procured for the Project shall be fundamentally considered as shown in the following Table.

ITEM	Origin		
	Japan	Honduras	Other
Small-Scale Hydroelectric Power equipment			
Turbine	○		
Generator	○		
Turbine/generator Control System	○		
Low Voltage Distribution Cubicle	○		
Control System	○		
Medium Voltage Switchgear			○
Power Transformer			○
Construction Materials			
Ready-Mix-Concrete		○	
Cement		○	
Sand·Aggregate		○	
Deformed bar		○	
Wood		○	
Ductile Iron Pipe, Steel Pipe (more than $\phi 200$ mm)			○
Valves			○
Electric line pole		○	
Construction Machines			
Crane		○	
Backhoe		○	
Dump Truck		○	
Bulldozer		○	

Main components of the small-scale Hydroelectric Power generation, such as a turbine, dynamos, and an operator control panel etc, are premised on Japanese-made supply.

32

Local Equipment & Material

Construction material



Concrete plant



Construction machine



Transportation of Equipment from Japan

The small-scale-Hydroelectric Power related electrical items procured in Japan will arrive at the sole international port in El Salvador, Acajutla. The target sites are located in Tegucigalpa, which is located about 400km from the port. However, there are many experienced transport companies in Tegucigalpa and the access roads from the port to the sites are well maintained. Therefore, there is no concern related to the local transport of the materials from Japan.

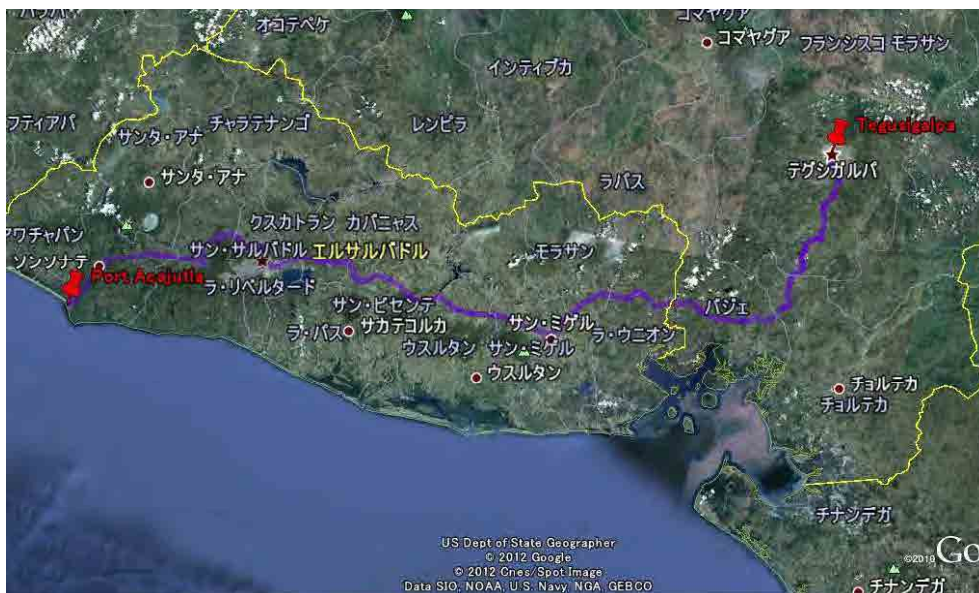

Concepcion Construction Site

Powerhouse site



New pipeline route



Picacho Construction Site



35

Implementation Schedule

Based on the grant aide scheme of Japan, preliminary implementation schedule is drawn up as shown below.

Pre-Implementation	Total Seven Months																	
	1	2	3	4	5	6	7	8	9	10	11	12	13	14	15	16	17	
Contract	█																	
Field Survey		█																
Desk Study			█															
Bidding Process				█														

Implementation	Total Sixteen Months																	
	1	2	3	4	5	6	7	8	9	10	11	12	13	14	15	16	17	
Manufacturing/ Transportation	█																	
Installation Works (include test run)													█					
Civil Works				█														

In this project, the time necessary for completion is mainly determined by the process of manufacture and delivery of small-scale Hydroelectric Power equipment, installation, and adjustment works. The other construction works, such as pipeline works, proceed in parallel with the manufacture and delivery of the small-scale Hydroelectric Power equipment. 36

Allocation of Chief Responsibility

No.	Items	To be covered by Grant Aid	To be covered by Recipient Side
1	Acquisition and free provision of land necessary for the project		●
2	Acquisition and free provision of land necessary for the temporary works and the land clearance		●
3	Provision of waste disposal sites		●
4	To construct roads within the sites	●	
5	To maintain the roads outside of the sites		●
6	Procurement of Small-Scale Hydroelectric Power equipment	●	
7	Installation of Small-Scale Hydroelectric Power equipment	●	
8	New Bypass Pipeline Construction (Concepcion)	●	
9	To connect the new power line to the existing infrastructures	●	
10	Provision of free water for the construction works		●
11	To bear the following commissions applied by the bank in Japan for banking services based upon the Bank Arrangement (B/A): 1) Payment of bank commission		●
12	Application and acquisition of permits and licenses required for the construction works		●
13	To ensure all the expense and prompt execution of unloading and customs clearance at the port of disembarkation in the recipient country		
	1) Marine or air transportation of the products from Japan or third countries to the recipient	●	
	2) To ensure all the expense and prompt execution of unloading, tax exemption and customs clearance of the products at the port of disembarkation		●
14	3) Internal transportation from the port of disembarkation to the project site	●	
	To accord Japanese nationals and/or nationals of third countries, including persons employed by the agent whose services may be required in connection with the Components such facilities as may be necessary for their entry into recipient country and stay therein for the performance of their work.		●
15	To ensure that customs duties, internal taxes and other fiscal levies which may be imposed in the recipient country with respect to the purchase of the Components and to the employment of the Agent will be exempted by the Government of recipient country.		●
16	To maintain and use properly and effectively the facilities that are constructed and the equipment that is provided under the Grant.		●
17	To bear all the expenses, other than those covered by the Grant and its accrued interest, necessary for the purchase of the Components as well as for the agent's fees.		●
18	To ensure environmental and social consideration for the Programme.		● 1

Obligations of Honduras Side and the Allocation of Responsibilities

	Obligations	Allocation of responsibilities
1	Acquisition and free provision of land necessary for the project	The SANAA
2	Acquisition and free provision of land necessary for the temporary works and the land clearance	The SANAA
3	Provision of waste disposal sites	The SANAA with Tegucigalpa municipality
4	To maintain the roads outside of the sites	The SANAA with Tegucigalpa municipality
5	Provision of free water for the construction works	The SANAA
6	To bear the commissions applied by the bank in Japan for banking services based upon the Bank Arrangement (B/A) (ex; Payment of bank commission)	The SANAA
7	Application, acquisition of permits and licenses required for the construction works	The SANAA with relevant institutions and Tegucigalpa municipality
8	To ensure all the expenses and prompt execution of unloading and customs clearance at the port of disembarkation in the recipient country	The SANAA
9	To accord Japanese nationals and/or nationals of third countries , including persons employed by the agent whose services may be required in connection with the components such facilities as may be necessary for their entry into recipient country and stay therein for their works	The SANAA
10	To ensure that customs duties, internal taxes and other fiscal levies which may be imposed in the recipient country with respect to the purchase of the Components and to the employment of Agent will be exempted by the Government of recipient country	The SANAA with relevant institutions
11	To maintain and use properly and effectively, the facilities that are constructed and the equipment that are provided under the Grant	The SANAA
12	To bear all the expenses, other than those covered by the Grant and its accrued interest, necessary for the purchase of the components as well as the agent's fees.	The SANAA
13	To ensure environmental and social consideration for the Programme	The SANAA with relevant institutions

Operation and Maintenance Cost

(1) Labor Cost of Operation and Maintenance

	Name	Number of staff	Salary
1)	Operators	4 personnel × 2 Sites = 8 personnel	Lp.15,000/month × 8 personnel= Lp.120, 000
2)	Maintenance Crews	2 personnel	Lp.20, 000/month × 2 personnel= Lp.40, 000
			Lp.160,000/month

(2) Purchase Cost of Spare Parts

	item	amount
1)	a regular basis is a kind of valve seals and turbine shaft water seal packing.	Lps.24,000/year

(3) Other Direct Costs (Consumables)

	item	amount
1)	Consumables such as printer cartridges of the printers for the control system, grease for the generator and office supplies	Lps.12,000/year

(4) Overhaul Costs, etc.

	item	amount
1)	The overhaul of the turbine and the generator in every 10 years The replacement of turbine water seal packing and the valve seals	Lps.718,000/10years

Necessary spare parts are delivered in this Project. If spares are used in the repairing work, it is necessary to purchase and keep them for future maintenance.

3

Land Acquisition for the Project

	Location	Required area	Remarks
Concepcion site	Powerhouse site	Powerhouse site : 30m x 19.3m	Excluding space between the boundary and anterior road, neighboring aerator
	Buried pipeline route (garden of private house)	Pipe length :about 30m	
	Buried pipeline route (community land)	Pipe length :about 100m	
Picacho site	Powerhouse site (including Access road)	Powerhouse site: 600m ² Access road: 430m ²	Excluding space between the boundary and private house below.

Others

- Relocation of existing distribution water pipeline, which cross the powerhouse site to be constructed (steel pipe ID 150mm, length 48m) at Picacho site
- water stoppage to bifurcation of new pipe from existing pipeline
Concepcion site: 4 locations, 2 along the existing pipeline, 2 in powerhouse
Picacho site : 2 locations in powerhouse

4

Land Acquisition for the Project

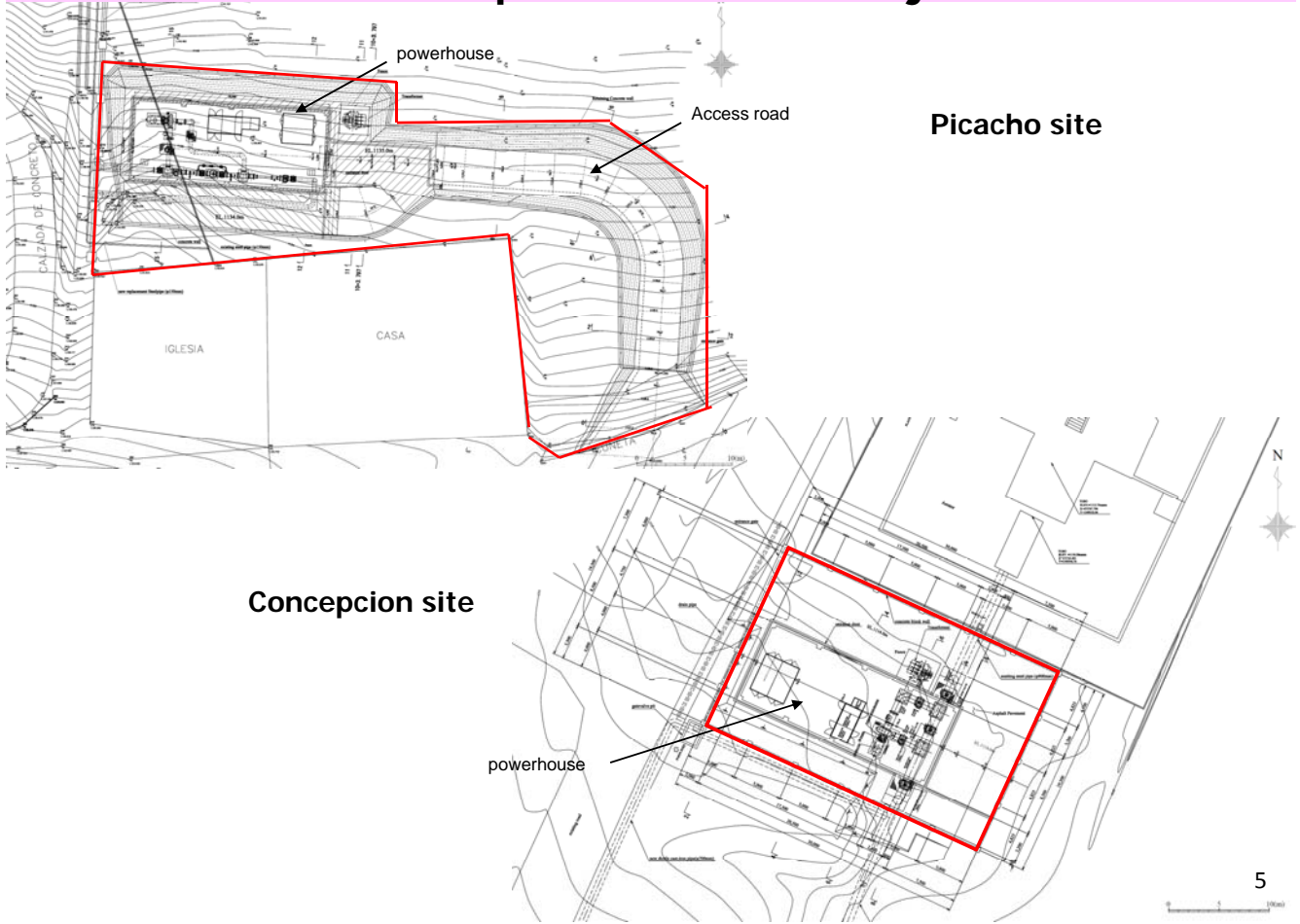

Construction required for Water Stoppage

