

*Appendix 1-1 Disaster Impact Assessment - Trial for  
Road Sector-*



# Disaster Impact Assessment

- Checklist System for Road Sector -



DMC & JICA DiMCEP  
2012. December  
A-1-1





**Guideline**



# Guideline for DIA Checklist System of Road Development Sector

## SECTION 01 - INTRODUCTION OF DIA SYSTEM

### 1.1 Disaster Impact Assessment (DIA)

- Disaster Impact Assessment (DIA) is a methodology to assess development projects from the viewpoint of disaster risk reduction by identifying improvement points of the projects. Based on the findings, revisions to the projects will be incorporated for reduction of disaster risks and mitigation of potential effects happened to and from the project activities.

### 1.2 Background

- Sri Lanka is at present in an accelerated path of development after end of thirty year civil conflict. With the expedite development phases, number of conditions that seem to trigger the disasters were identified. Such situations had resulted in project developments due to lack of detailed studies to clarify the potential disaster impacts. Therefore, the government has a responsibility to minimize disastrous situations along with the development programs. In such context, it is necessary to incorporate disaster assessments for development projects in Sri Lanka.

### 1.3 Importance of Disaster Impact Assessment (DIA)

- Disasters can create considerable damages and losses related to development projects. Therefore, measures to be taken from the beginning of any development activities to avoid such impacts.
- With the aim of minimizing the damages and losses, actions such as analyses the causal factors of the disasters, anticipated damages and appropriate countermeasures are required at each stage of the projects. These important actions are based on the result of DIA. Revisions will be requested by the DIA to improve the standards of structural countermeasures, adjustments of design conditions and non-structural countermeasures such as evacuation plans, early warning mechanisms.
- If the DIA system is incorporated into the processes in development projects, the extent of damages and losses could be avoided or minimized at higher degrees. Therefore, Disaster Impact Assessment (DIA) for evaluating project takes a high importance in its existence.

**1.4 Classification of the Disasters for DIA**

- According to the DIA considerations for any development sector, the foremost fact to be considered is to define and differentiate the types of disasters more clearly.
- Related to the development projects, there are three types of disaster situations. The first situation is a disaster caused by development actions to the surrounding area. Second is disasters happened to the development action itself. And the third is a disaster to the surrounding area caused by the development action which had been damaged by disasters. In case of second and third situations, the development actions are influenced by natural phenomena whereas, in the first situation, the cause is technical failure. Therefore, the difference between a first situation and situations of second and third needs to be identified and considered.

**Table 1.1 Situations of Disasters**

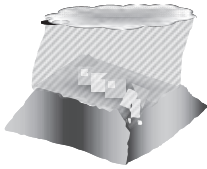
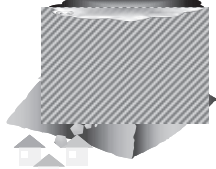
<p>1</p> 	<p>2</p> 	<p>3</p> 
<p>Disasters caused by development actions to the surrounded area</p>	<p>Disasters to the development actions itself</p>	<p>Disasters to the surrounding area caused by the development action which had been damaged by disasters</p>

- These two types of disasters can be defined as; Natural disasters and Technological disasters. In brief, natural disasters are originated due to natural happenings while technological disasters are created due to human interferences and/or technological failures.
- There are key differences of the natural and technological disasters. Natural hazards such as floods, tsunami, and cyclone are impossible to control. Technological hazards are possible to control with technological adjustments and well - managed human interference. Based on the nature of each type of disasters, the available countermeasures relevant to these disaster types are varied. Therefore, it is important to consider these disasters separately, based on countermeasures. Countermeasures against technological disasters are targeted to ensure a suitable design and maintenance process.
- As an example; if rainfall is extremely heavy, area near a culvert of a road may get inundated because of the size is not at sufficient capacity to drain off the volume of the upstream water

accumulated. This situation was created by the heavy rainfall and it acts as the natural hazard. If the rainfall is at normal level but the area near the culvert gets inundated because of the too small size of the culvert or the disturbed condition of the culvert with mud. In such cases, inundation can be considered as a technological disaster.

- Technological disasters can be further divided into two types. Type 01 is identified as disasters associated with the design and construction such as setting of design conditions. These design conditions are considered at design stage. Type 02 is referred to as disasters associated with the management and maintenance of the projects.
- This classification is utilized for analyses of the disaster impacts and clear understanding the framework of the concept.

**Table 1.2 Classification of Disaster**

Classification of disasters	
1. Natural Disasters	
2. Technological Disasters	2.1. Design & Construction stage
	2.2. Management & Maintenance stage

**1.5 Assessment Point of DIA**

- Two assessment points are prepared to assess with respect to the above two types of disasters.
  - Key considerations in DIA for the natural disasters is to check whether the countermeasures against foreseeable disasters are reflected in the management plan, usable condition and evacuation plan.
  - Key considerations in DIA for the technological disasters is to check whether the design is satisfied at required levels of design standards. In those considerations, structural countermeasures are considered in the designs.

**Table 1.3 Assessment Point of DIA**

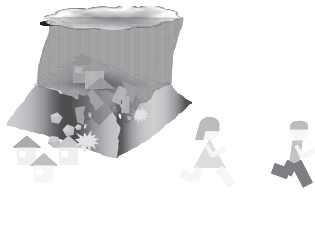
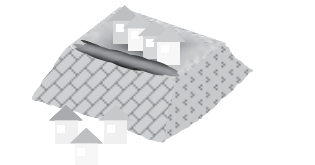
Key Point 1 Against Natural Disaster	Whether the countermeasures against foreseeable disaster are reflected to the management plan, usage condition, evacuation plan etc.	
Key Point 2 Against Technological Disaster	Whether the required level of design including structural measures are reflected to the design.	



## 1.6 Outcome of Disaster Impact Assessment (DIA)

- Consideration of conditions at design and construction stages is helpful to prepare appropriate countermeasures for disasters in advance. As examples, inclusion of structural countermeasures in the design can be highlighted. It helps to set design conditions at higher levels. Nonstructural countermeasures such as evacuation plans, early warning mechanisms can also be proposed accordingly. By those countermeasures, disaster damages on development projects can be mitigated.

**SECTION 2 - PROPOSED DIA SYSTEM FOR ROAD SECTOR FOR SRI LANKA**

**2.1 DIA Concept**

**2.1.1 Role of Design Condition**

- As mentioned in the Chapter 01, There are two requirements to fulfil on DIA. Firstly, natural and technological disasters need to consider separately. Secondly, DIA needs a margin line to divide these two disasters. For example, water flow through a drainage canal without clogging if the water amount is within the design condition. But, if the amount is more than design condition, then, overflowing will be resulted.
  
- Therefore, In case of DIA, the design condition is considered as the suitable margin line to divide the disaster type. In this approach, any designer can indicate the values which are used for the design. In this classification, the situations happened in more than / other than the design condition are treated as natural disasters and the situation within design condition is treated as technological disasters.

**2.2 Concept of DIA in Development Sectors of Sri Lanka**

- The role of the DIA is to point up the design conditions clearly. Based on that, natural and technological disasters can be obviously differentiated. Therefore, it is possible to define the risks and anticipating damages as much as possible against natural disasters. Also, it confirms the appropriateness of the countermeasures relevant to that potential risk. In case of technological disasters, it ensures the conditions not to trigger or generate disasters that are preventable by improvement of design conditions, introduction of countermeasures and continuous monitoring in service.

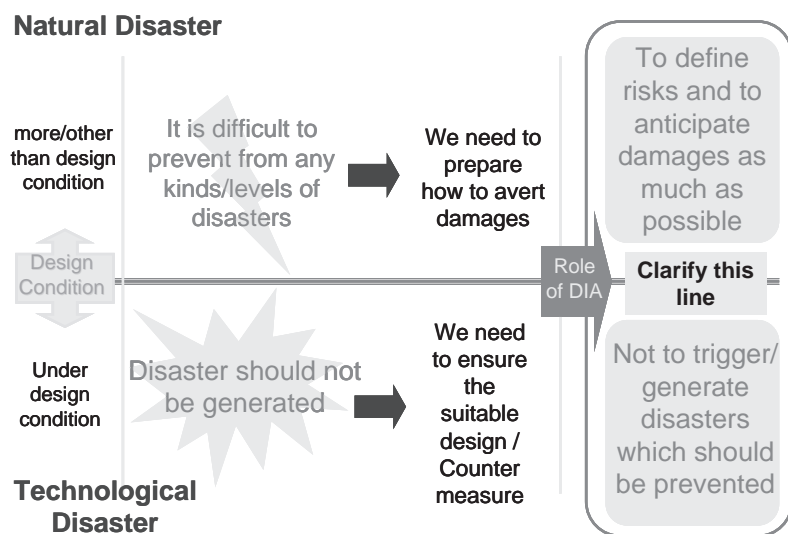

Figure 2.1 Role of DIA

### 2.3 Incorporate DIA system into existing systems

- The DIA should be prepared as a feasible system. It is appropriate to utilize with existing assessment mechanisms and therefore, it needs to arrange as an easy system to the responsible officers of the assessments.
- Assessment of any development project before its construction takes highest importance from the viewpoint of disasters. If the assessments of disaster impacts will be considered at each stage of the project, it is considered the ideal application status of DIA. For example, there are several key stages in any road development project such as pre-feasibility study stage including route selection, feasibility study stage and detail design stage. As the first step for incorporation of DIA system, the detailed design approval stage was selected.
- In addition, a disaster may occur due to insufficiency of maintenance. Once a disaster has occurred, preparations for the next event are essential. Therefore, establishment of a checking system at the maintenance (operational) stage will be supportive to seek the preparatory arrangements.

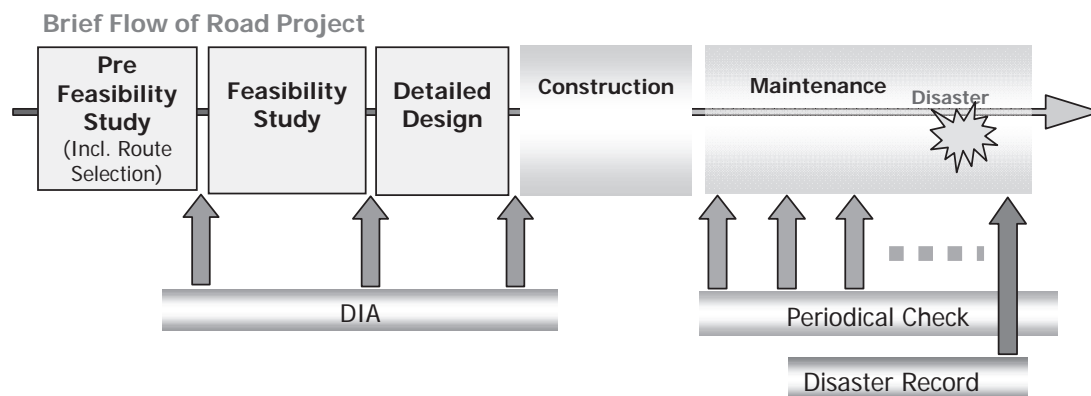

Figure 2.2 Ideal State of DIA

### 2.4 Establishment of the Continuous System

- With the objective of minimizing losses and damages created by disasters, it is important to review and revise the design standards and improve the maintenance system continuously. Establishment of a system to track records of the disasters, to share the information among the relevant agencies and to discuss about the causes of the disasters and countermeasures will be important to keep the system constantly. The design standards and guidelines, appropriate settings of design conditions and evacuation plans can be improved by repeated application in real situations. It strengthens the capacity of design and management against disasters.

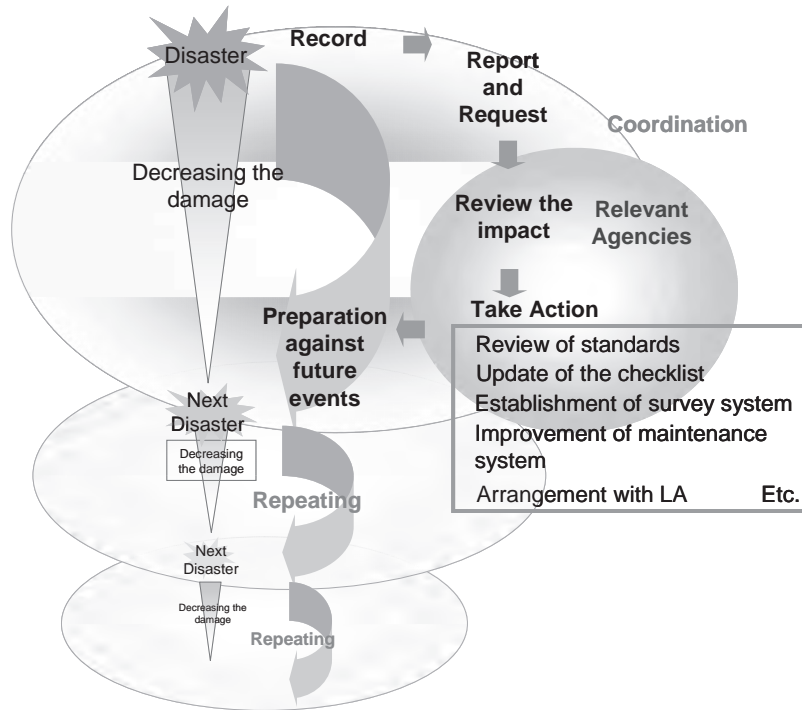

Figure2 .3 DIA System

**2.5 Objective of DIA Applications for Sri Lanka**

- The application of DIA to assess the projects stands with following key points;
  - I. It helps to assess the influences of disasters to the development actions itself
  - II. It helps to assess the influences of disasters in the surrounded area. These disasters are caused by the development actions which had been damaged by disasters and;
  - III. It helps to assess the influences of possible of disasters caused by development actions to the surrounded area
- and also it is confirmed countermeasures.

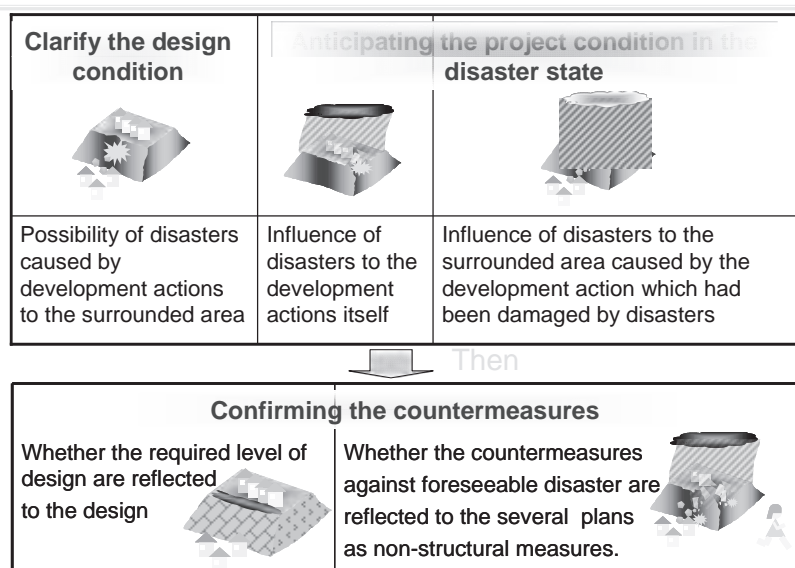

Figure2 .4 Objective of DIA





**Manual**



## SECTION 3 - DIA CHECKLIST SYSTEM IN ROAD DEVELOPMENT SECTOR

### **3.1 Background of Disasters Related to Road Development Projects**

- Among the development programs in any country, infrastructure facilities such as roads take high priority. It is true for Sri Lankan contexts too. There are a number of proposed and ongoing road development projects. With this rising trend of development, problems associated with road construction are also becoming more concerned aspects. With this background, Disaster Management Centre (DMC) has stepped forward to introduce DIA checklist system for road sector as the first development sector on trial. Since Implementation of DIA in original version shown in figure 2.2 is rather difficult to adopt in Sri Lankan context, the DIA system for the road development sector was considered in a customized format.

### **3.2 Policy to Develop DIA Checklist for Road Sector**

- Identification and assessment of disaster impacts and risks are mentioned as priorities in the “Hyogo Framework for Action 2005 – 2015”. Some countries have taken initiatives for incorporating applications of disaster impact assessments into their development projects. DIA is a novel idea to many countries including Sri Lanka. Therefore, a generalized model is not still found to adapt into the Sri Lankan scenario. In this background, DMC has initiated to support incorporation of DIA procedures into the existing project assessment systems.
- The policy to develop the DIA system are mentioned as follows;
  - I. Confirm the design conditions
  - II. Confirm the countermeasures against foreseeable disasters
  - III. Set manageable contents of DIA for RDA
  - IV. Disaster recording mechanism of the system to prepare for the next event

In this effort of incorporating DIA in to road development sector, several limits have been considered as follows;

- Bridge construction is not broadly considered in the checklists contents.
- Checkups for construction stages are not included in this application since it should be done prior to the approval of construction.
- Target hazards were limited to floods and geological hazardous conditions.



### 3.3 Composition and System of the Checklist

- DIA can be included into design approval as one of consideration points. This approval is applied by RDA, as a self assessment system of road projects. Since DIA still doesn't have a base with any collection of data, checklists are introduced as the initial step of incorporation. The suitable timing to conduct DIA for road sector was identified as the detailed design stage.
- The DIA contents were prepared based on the classification of the disaster. (See Table 1.2)
- At first, it needs to confirm the safety of the development project as a "construction". It means, assessment is needed to check whether the design is appropriate to satisfy the design conditions, and whether construction works are done as designed. This step is aimed at preventing the damages related to failures of the project design and construction to the surrounding area in the normal condition. These considerations are responsibilities of design and construction work. Technically this needs to be confirmed through one of design or construction approval, and it cannot be treated as DIA.
- Secondly, the situations and relevant countermeasures assess for the conditions, which may happen at more or other than design conditions. It helps to foresee which kind of impacts will be possible. It is important to consider how to reply such beyond the normal situations. In this means, the checkup mechanism is useful to reduce the damages caused by constructions in situations beyond capacity (such as overflow, collapses). It needs to be done in the situation more or other than design condition. This is the main part of DIA considerations.
- After completion of a road development project, it will be in-service for long duration. During this project life span, project specific conditions and its environmental conditions may change due to the changes of geological conditions and aging of construction. Therefore, it needs to define the hazardous situation continuously. This checkup is necessary to prevent damages caused due to the changes of the existing conditions. At the third stage, this affirmation can be achieved by periodical checkups. This is a responsibility at the maintenance stage.
- Even if the checkups are done, some disasters may be possible to occur with the project. Therefore, it is important to examine the reasons of such situations. In this case, discussions with related organizations are required to consider suitable countermeasures. Keeping records of the disaster situation is a vital aspect in terms of further inspections and improvements.
- As mentioned in section 1.4, natural disasters and technological disasters should be considered separately. Based on these classifications and survey results relevant to road sector, three key points for use of the checklists on road projects are focused on such as (1) which countermeasures are considered at design stage? (2). What should be prepared against the

natural disasters and (3). How to identify the hazards after in-service?. Based on these three points, three types of checklists have been prepared for checkups relevant to design, disaster management and inspection at maintenance. With the purpose of keeping records of the disaster events to review the relation to damage and countermeasures, checklist forms related to disaster record have been introduced.

Classifications		Checklist types	Focus Points	Contents
Natural Disaster		<b>Form B</b> Disaster Management	What should we prepare against the natural disaster?	Understanding in which condition the construction is designed. And also the non-structural measures, cooperation with local government and related organizations etc. are confirmed.
Technological Disaster	Design Construction	<b>Form A</b> Design	Which countermeasures are considered at design stage?	Confirmation of design standard and design condition. And also hazard locations and road structure locations including structural measures are confirmed.
	Management Maintenance	<b>Form C</b> Inspection	How to identify the hazards after in-service?	Inspection of the condition of hazardous locations and road structures including structural measures by periodical checkup
After Disaster		<b>Form D</b> Disaster Record	How was the affected situation by the disaster?	Record of the disaster situation by site visits and interviewing people in the affected area

Figure 3.1. Composition of Checklists

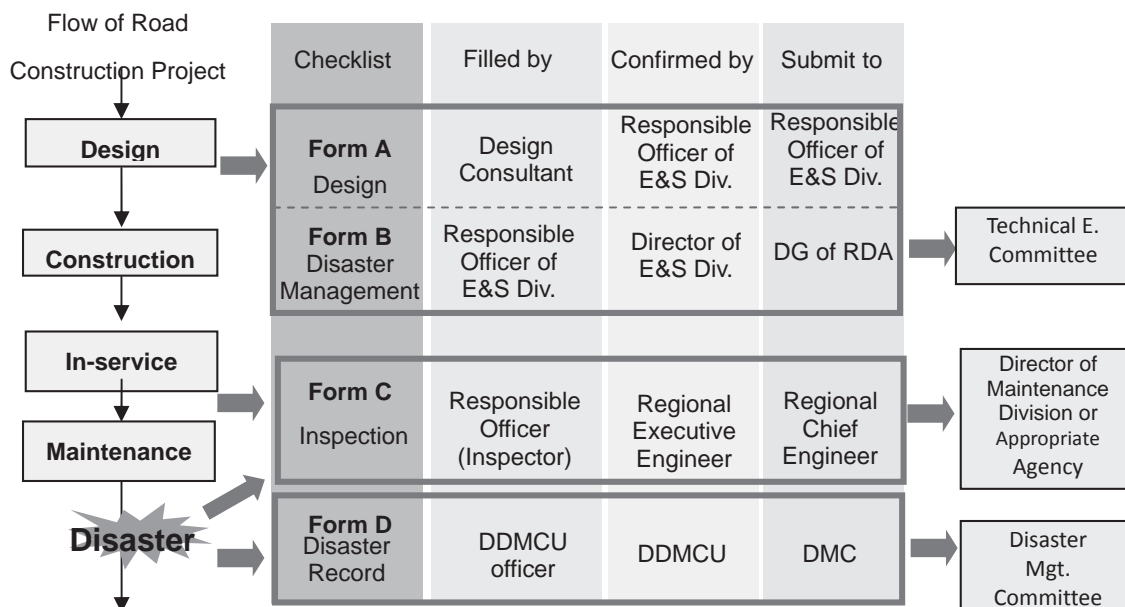

Figure 3.2. Proposed system of DIA for Road Sector

### 3.4 Contents of Checklist Forms in Road Development Sector

**Table 3.1. Contents of checklists**

Type	Objective	Contents	Timing of conduct	Submission
Form A Design	The conditions which are considered at the design stage are shown clearly.	Confirmation of design standard and design condition. And hazard locations and road structure locations are confirmed.	After Design	Filling up by : Design Consultant Confirmed by : D/ESD Submit to : Technical Evaluation Committee
Form B Disaster Management	Countermeasures to minimize the damage against the situation more/other than design condition are confirmed.	Nonstructural measures, cooperation with local government and related organizations etc. are confirmed.	After Design	Filling up by : E&S responsible officer Confirmed by : D/ESD Submit to : DG / ADG of RDA Evaluate by : Technical Evaluation Committee  <i>(Submission of both A &amp; B Checklist in combined set)</i>
Form C Inspection	The conditions of the natural and structural states are identified.	<u>Screening :</u> The locations for inspections are found out.	Immediately After putting into service and annual screening	Filling up by : Executive Engineer Confirmed by: Chief Engineer Submit to : D/Maintenance Div. Request to : Appropriate Agency  *Inspection Sheet: Filling up by : Specialist of the Appropriate Agency Confirmed by : Chief Engineer
		<u>Inspection:</u> The detail conditions of the hazardous locations are confirmed.	Annual (Based on requests by the screening result)	
		<u>Disaster Record:</u> The situation of the disaster is recorded.	After the disaster occurred	
Form D Disaster Record	Disaster situation is recorded to be utilized in the future.	Disaster situation is recorded by site visits and interview with people in the affected area	After the disaster occurred	Filling up by : DDMCU Confirmed by : DDMCU Submit to: DMC / DDMC

### 3.5 Role of checklist system with existing assessment system and its' future development

- Checklist Form A will be utilized to confirm whether the design conditions are checked against the hazardous considerations. Checklist Form B will be confirmed whether non-structural measures cover the deficit of insufficient structural measures, in the above normal conditions. Checklist Form C will be supported in maintenance system to identify the hazardous conditions during an in-service period of the road.
- Once a disaster event occurred, that particular event will be recorded by Checklist Form D. Based on this record, relevant organizations can arrange restoration & mitigation for the identified problematic locations. Therefore, it has high potential to contribute mitigation of disaster damages using any methods (both structural and non-structural measures).
- These checklists are one part of DIA system. It needs to add the other parts and continue improvement stepwise with the improvements. It is expected to realize capacity development for disaster management through DIA Application.

- For Sri Lanka, preparation of own design standards will be required. At that time, checklist based recording conditions (applied design standards, level of design conditions, effectiveness of the non-structural measures) can be utilized to know the real status of the impact. These records will be helpful to develop countermeasures for the future projects.
- As a future development, the checkups of Form A can play a role of project design approval. It guarantees a suitable and safer design of the road. Form B, C and D will promote appropriate usage (including management) of facilities. It will ultimately ensure sustainability of the project.
- Application of checklists also consists of limitations. For example, without any focused, comprehensive studies, it is difficult to assess the appropriateness of design conditions in the point of disasters. Therefore, The DIA checklist system seems its place as the base for development of the full version of DIA system.
- Though this checklist system is a part of the DIA system, collection of the records by each form will be useful for preparation for future disaster events. After any disaster event, the situation will be recorded by Disaster Record Sheets and Checklist Form D. Based on these records; relevant agencies are able to take actions such as review of standards, decision making on appropriate countermeasures etc.
- These actions will arrange preparation against future disastrous events. With the application in real situations, the damage in next disaster events can be minimized. The capacity of the strengthening of risk-reduced development will be gradually improved. (See Figure 2.3)
- As further development of the DIA system, the DIA for route selection stage and design policy stage also required to establish. Disaster consideration for the development will be taken from the initiate stage of the project is important. By keeping records of design, countermeasures, maintenance and disasters, the actions for next steps will be ready to prepare.

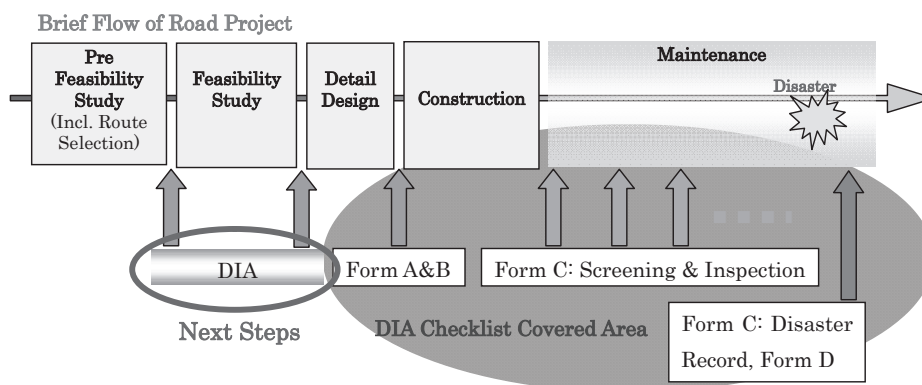

Figure 3.3 Feature Development of DIA

## ANNEXES

### Definitions related to DIA

**Disaster:** “Disaster” means the actual or imminent occurrence of a natural or man-made event, which endangers or threatens to the safety or health of any person or group of persons in Sri Lanka, or which destroys or damages or threatens to destroy or damage any property (*Sri Lanka Disaster Management Act, No. 13 of 2005*)

**Natural Disaster:** Natural processes or phenomena occurring in the biosphere that may constitute a damaging event. Natural disasters can be classified according to their (1) hydro meteorological, (2) geological or (3) biological origins.

Origin	Phenomena / Examples
<u>Hydrometeorological hazards</u> Natural processes or phenomena of atmospheric, hydrological or oceanographic nature.	<ul style="list-style-type: none"> <li>▪ Floods, Debris and Mudflows</li> <li>▪ Tropical Cyclones, Storm Surges, Wind, Rain &amp; other Severe Storms</li> <li>▪ Lightning</li> <li>▪ Drought, Desertification, Wild line Fires, Temperature Extreme Sand &amp; Dust Storm</li> <li>▪ Permafrost, Snow Avalanches</li> </ul>
<u>Geographical Hazard</u> Natural earth processes or phenomena that include processes of endogenous origin or tectonic or exogenous origin such as mass movements.	<ul style="list-style-type: none"> <li>▪ Earthquake</li> <li>▪ Tsunami</li> <li>▪ Volcanic activity and Emissions</li> <li>▪ Mass Movements, Landslides,</li> <li>▪ Rockslides Liquefactions, Sub-Marine Slides</li> <li>▪ Surface Collapse</li> <li>▪ Geographical fault activities</li> </ul>
<u>Biological Hazards</u> Processes of organic organs or those conveyed by biological vectors, including exposure to pathogens, micro organism, toxins and bioactive substances.	<ul style="list-style-type: none"> <li>▪ Outbreaks of Epidemics</li> <li>▪ Plant or Animal Contagion</li> <li>▪ Extensive Infestation</li> </ul>

(Source: *www.dmc.gov.lk, 2011*)

**Man-made disaster:** Disastrous event caused directly and principally by one or more identifiable, deliberate or negligent human actions. (Source: *www.dmc.gov.lk, 2011*)

**Technological disaster:** Danger originates from technological or industrial accidents, dangerous procedures, infrastructure failures or certain human activities, which may cause the loss of life or injury, property damage, social and economic disruption or environmental degradation. Some examples: industrial pollution, nuclear activities and radioactivity, toxic wastes, dam failures, transport, industrial or technological accidents (explosions, fires, spills). (Source: *www.dmc.gov.lk, 2011*)

### **Environmental Impact Assessment:**

Environmental Impact Assessment (EIA) is the systematic examination of the likely impacts of development proposals on the environment. It is conducted prior to the beginning of any activity of the project (Source: *http://www.ncte.ie/environ/eia.htm*). The key objectives of EIA are to facilitate in

decision-making based on the foreseen effects of the project, to design/implement appropriate monitoring, mitigation and management measures and to propose acceptable alternatives. A EIA is critically important for projects requiring a major change in land use or those that are to be located in environmentally sensitive areas (*Source: <http://www.businessdictionary.com>*). EIA is highly recognized in Sri Lanka, as an effective tool for integrating environmental considerations into development planning. Thus, the EIA can be considered as a major planning tool and one of the key techniques to achieve sustainable development. Under the National Environmental Act and other legislations, EIA is a mandatory requirement for establishing development projects in Sri Lanka (*Source: [www.cea.lk/EIA](http://www.cea.lk/EIA)*).

### **Disaster Impact Assessment:**

Disaster Impact Assessment (DIA) is still not so far defined into a fixed definition. Nevertheless, the concept has been elaborated in several prior studies. According to them, the idea of DIA has been explained/ defined in following ways,

**Reference** : **Korea** “Impact Assessment Act for Environment, Transportation, and Disaster” ; Article 2 (definition) Disaster Impact Assessment : Taking countermeasures for the projects based on the result of prediction and analysis against the disaster such as flood. <Translated by DiMCEP; > (Source: “Impact Assessment Act for Environment, Transportation, and Disaster” <http://www.lij.jp/html/hourei/kankoku/kan/kan023.pdf>; Note: it was revised as “Impact Assessment Act for Environment” on 1st January, 2009)

**Japan** “Proposal for the Disaster Assessment System” ; Definition of the “Disaster Assessment” : Disaster assessment is novel strategy and project assessment concept try to be like Environment Impact Assessment. Moreover, the objective of DIA is an enhancement of the mitigation and adaptability against any natural disasters. The function of Disaster Assessment has conducted early assessments for the development projects whether it satisfies the disaster criteria in the area. (...) It will be evaluated by periodical monitoring whether the low risk aspects against disasters is guaranteed or not until completion of a series of the project. (The rest is omitted) < translated by DiMCEP> (Source: “ Proposal for the Disaster Assessment System” JSCE Magazine, “Civil Engineering” vol. 97 No.4 April 2012)

## Manual for Checklist Forms A & B

- Checklist Forms A & B consists of 03 sections. They are in the combined form. The set consists of following 03 documents.

1. Covering Page: The cover page consists of questions on background information, maps, official authorization and submission of the checklist contents.
2. Checklist Form A: Confirmation of design standard, design conditions, design policy for route selection and hazards along the road.
3. Checklist Form B: Confirmation of disaster experience in the project area, identification of hazard, countermeasures, confirmation of monitoring arrangements during the construction stage.

- The Checklist Form A is used to check and confirm whether the design conditions of the road are set accordingly to the design standards. Therefore, Checklist A helps to ensure the fulfillment of design condition to follow the design standards.
- The Checklist Form B is used to check and confirm the potential situations with the extreme levels (above design conditions) than the design conditions proposing with structural and/or non-structural countermeasures. Checklist B helps to examine and foresight the extreme situations beyond the capacity designed by the design standards.

- The sets of Checklist Forms A & B are available with Environment & Social Development Division (ESD). Whenever the project design completed, the ESD Division starts to do the assessment. The Checklist Forms A & B with Cover Page need to be filled in the following way.

1. Nomination of a Responsible Officer (hereafter referred as “Responsible Officer”) from Environment & Social Development Division for the DIA. The nomination is done by Director, Environment & Social Development Division. The Responsible Officer will be the Focal Point on Checklist Forms A & B.
2. The Responsible Officer sends Checklist Form A to the Design Consultant of the designed project (or road development).
3. Checklist Form B is filled by the Responsible Officer with the help of the Project Design Report and consulting relevant divisions / officials.
4. Completed Checklist Forms A and B (with the Cover Page) will be signed, confirmed and forwarded to the Director, ESD by the Responsible Officer.
5. The Director, ESD certifies the forms by signing in Covering Page. Thereafter, the set of completed checklist forms will be submitted to the Director General, RDA (and/or Additional Director General -Projects) for further actions and revisions on recommendations through Technical Evaluation Committee (TEC).

**CHECKLIST FORM A:****1-Confirmation of Design Standard:**

- Question No. 01 stands for confirmation of design standards. The overall design standards show the total image of the set design. It is used to confirm the applied standard (Question No.1.1). In addition to the overall standard, the other specific standards relevant to each type of structures and design measures are separately confirmed. Those are more specifically confirm the design standards on cuttings, fillings, embankments, drainage, bends, retaining walls etc. (Question No.1.2).

**2-Confirmation of Design Parameters and Conditions:**

- Question No. 2.0 stands for confirming information of Design Parameters and Conditions used for the project.
- Map requests in Question 2.1: A map showing the route and marking the hazard sites by Design Engineer to understand the situation of the road is sufficient if prepared with available technical capacity of designers / project related facilities (Example is attached as Map 01) More detailed maps / sketches of each hazard specific site is required to attach prepared with available technical capacity of designers / project facilities (One example is attached as Map 02).
- Climate divisions are classified as Wet Zone, Dry Zone and Intermediate Zone.
- The rainfall related values that are considered for determining in the design are vital in the decision of the demarcating rainfall normal levels with extreme levels. Based on the design methodology, the rainfall related value used for the design might be different. The value may be Annual Average Rainfall (AAR), Recorded Maximum Rainfall (MRF), Recently Recorded Maximum Rainfall (RMRF) or other. One or more of them will be considered in the calculations in the designs.
- Rainfall values used for the design may be mostly Annual Average. In situations where using other parameters (Maximum, Minimum, Intensity etc.), those can be considered with the consultation of relevant technical agencies (Department of Meteorology, NBRO etc.).
- The geographical features of the project alignment and nearby area are requested to consider based on the classifications as flat land, hilly area, mountain area, coastal area, urban area, rural area, sub urban area and other categories. All applicable categories can be marked in the list.



- **Remarkd public facility along the road:** This section is to confirm the key public facilities existing / proposing by the project to establish along the road such as bus halting places, public gathering places ( weekly fair, religious places, schools, towns, public centers, hospitals, factories, offices etc.). In case of hazardous conditions, confirmation of such critical sites is important to consider more carefully. They can be listed with exact location details and referring to the route map mentioned above.
- The question on “events or festivals considered for the design” refers festivals / events such as public gatherings at some locations on or nearby the road. Some examples are New Year festivals, pageants at temple, church or mosques, weekly fair etc. Such events are mostly happening periodically. Therefore, it needs to consider those public events in the road design.

2.1 Natural condition and remarkable conditions	Please attach Route map (Location map) <span style="float: right;">① Attached <input type="checkbox"/></span>
	Climatic division; <span style="float: right;">Wet Zone <input type="checkbox"/> Intermediate <input type="checkbox"/> Dry Zone <input type="checkbox"/></span>
	Rainfall value considered for the design: ..... mm ..... mm/h Annual Average <input type="checkbox"/> Record Max <input type="checkbox"/> Recently Max <input type="checkbox"/> Others <input type="checkbox"/> ..... Just follow the standard <input type="checkbox"/> Not discussed <input type="checkbox"/>
	Features of the location ; mark all that apply Flatland <input type="checkbox"/> Hilly area <input type="checkbox"/> Mountain area <input type="checkbox"/> Coastal area <input type="checkbox"/> Urban area <input type="checkbox"/> Rural area <input type="checkbox"/> Suburban area <input type="checkbox"/> Others <input type="checkbox"/> .....
	Remarkd public facility along the road;
	Events or festivals considered for the design; No <input type="checkbox"/> Yes <input type="checkbox"/>

- Question No. 2.2 stands for confirming the design conditions. Design conditions are confirmed with the values that are most relevant to disaster considerations. Design speed, design traffic volume, probable rainfall return period and rainfall intensity are the key assessment points. In case of probable rainfall return period and rainfall intensity, the values on waterways based on their sizes are needed to define for the design levels. The set figures in tables for large river, middle class river, canals crossing the main road, canals crossing with sub roads to main road, road gully and drainage are important to calculate and prepare for rivers or waterways. As an example, Outer Circular Highway Project (OCH) has such consideration for Colombo area.
- Question No.2.3 stands for vehicle related restrictions. Vehicle restrictions are considered based on the design of the vehicle and load restrictions.

Fill in the decided values in the design. If they comply with the standards listed above in Q1.1 and Q1.2, please mark “Yes”. If not, please mark “No” and specify the reason in \*\* marked boxes.

2.2 Design Conditions	Design Speed					Km/h
	Design Traffic Volume					ADT/day
	Probable Rainfall Return Period and Rainfall Intensity					
	- Rivers					Years mm/h
	- Streams					Years mm/h
	- Canals					Years mm/h
2.3 Vehicle Restrictions	Design Vehicle	Passenger Car <input type="checkbox"/>	Typical Heavy Truck <input type="checkbox"/>			
		Others <input type="checkbox"/>	Semi-trailer <input type="checkbox"/>			
	Load Restriction			t	Yes	No
	Vehicle Class					

**3 - Design Policy for Route Selection:**

- The priority considerations of route selection are important to consider because the policy for the selection will be a decisive factor at the initial time of the project with respect to hazardous areas. This may be before or during the pre - feasibility level.
- In Question No. 3.3, countermeasures proposed (discussed to arrange within the project design) itself as the response for the identified hazards by the project design in route selection can be enlisted here. As an example; if the project lies along a flood prone area, measures to prevent/ minimize the impacts of floods for the project are initially considered at the selection / planning stage. Those measures (may be structural measures or non structural) are confirmed by this question.

3.1	Please specify the reason of emphasis on route selection;
3.2	Recognized hazard along the selected route; Not recognized or considered <input type="checkbox"/> Landslide <input type="checkbox"/> Flood <input type="checkbox"/> Heavy rain <input type="checkbox"/> Strong wind <input type="checkbox"/> Slope failures <input type="checkbox"/> Tsunami <input type="checkbox"/> Others:
3.3	Please specify the main countermeasures to response the above hazard

**4 - Hazards along the Road:**

- In Question No. 04, when you prepare the maps (Q2.1), Question No. 4.1 in tabular form needs to be filled simultaneously. Along the road traces, it is confirmed whether the following conditions exist or not. If such locations / conditions exist along the road, the column 02 of the table is marked with “Yes”. If the answer is “Yes”, that means, hazardous condition exists. In such situations, it needs to confirm whether more recorded data / information on those identified hazardous conditions are available or not relevant to previous / present events or inspections by relevant technical agencies. If such information / records available, the answer in column 03 is “Yes”. Those potentially hazardous conditions are given as below.

1. Landslide hazard area *(can be checked based on the NBRO records)*
  2. An area more than 30 degree slope *(can be checked based on the topographical maps)*
  3. Flood hazard area or recorded flood area *(can be checked based on the Irrigation Dept., DMC or any other reliable sources)*
  4. Crown land reservation *(can be checked with relevant department / base maps)*
  5. Natural forest reserves *(can be checked with relevant department / base maps)*
  6. Coastal conservation areas *(can be checked with relevant department / base maps)*
  7. Wetlands / Marshy land areas *(can be checked with relevant department / base maps)*
  8. Other designated conservation area (Archeological/ Cultural) *(can be checked with relevant department / base maps)*
- Within the Question No. 4.2, a sub-question refers to confirming the preparation of drawing a plan of drainage system. Drainage system relevant to road consists of structures such as culverts and lateral drainage canals etc. In the design plan, the drainage system has to be arranged as one of the required parts of the design. Sometimes, it might not be prepared for some old road designs. If the drainage system is not in a satisfactory condition, it will be indicating that the design is not appropriate or not at a satisfactory level against disasters. Therefore, it needs to confirm whether the drainage system has been prepared or not and based on that, to confirm the countermeasures has been considered or not relevant to potential hazardous locations.

4.1	Please prepare map data below. Please mark hazard exists or not along the road. If "Exist", please mark the area data is exist or not.	Hazards exist along (near) the road? Y /N	In case of existing hazard, data available? Y /N
	- Landslide hazard area		
	- Area more than 30 degree slope		
	- Flood hazard area or recorded flood area		
	- Crown land reservation		
	- Natural forest reserves		
	- Coastal conservation areas		
	Wetlands / Marshy land areas		
	Other designated conservation area (Archeological/ Cultural)		
4.2	Did you prepare drawing a plan of drainage system?	Yes <input type="checkbox"/> No <input type="checkbox"/>	

- Map in Q 4.3 (Attachment 02) will be an extension / further development based on the Maps in Q 01. Here, the Prepared Design Plan with Auto CAD by Highway Design Division (or Project Consultants) can be overlaid on detailed map sections of hazard locations (attached as sub attachments of Attachment 01). These maps will be prepared in two scales. One is 1:10,000. Another is 1:1000. 1:10,000 map can show the geographical hazards. 1:1000 map can show the structural hazards. This will elaborate structures along the road, cuttings, fillings and other additions/ modifications of the road in a detailed way. Simultaneously, the road structures shown in the map are indicated in the table attached as Attachment 03. The map of drainage network related to the road is needed to attach as Attachment 04 (it refers to the Question No. 4.2).

4.3	Please prepare a map with above data and <u>road plan</u> with the location of the structures. Two types of Maps (1:10,000 & 1: 1000 needs to be attached)	②Attached <input type="checkbox"/>
4.4	Please prepare a table* of <u>road structures</u> and structure measures considerations. * Please use table format for Form A	③Attached <input type="checkbox"/>
4.5	Please attach a map of Road plan with Drainage network of the road	④Attached <input type="checkbox"/>

**CHECKLIST FORM B:**

- By the checklist Form B, the potential disaster situations in case of the natural conditions occur than the design conditions and possible countermeasures adopted by the development project will be checked and confirmed.

**5- Disaster Experience in the Project Area:**

- In Question No. 5.1, type of the disasters relevant to the project is taken into consideration with their frequency of occurrence, maximum recorded levels / extents of past damages are confirmed based on the past records. If there are not previous events or no available information, then the response will be “No information.” If the details exist, those disaster situations are confirmed with more details in Question 5.2. (Causes, impacts, damages, potentials of further occurrences, the triggering factors such as human activities and other special situations, previous/ existing countermeasures etc.)

5.1 Disaster record	Which kind of disaster experience had in the project area <input type="checkbox"/> Inundation      Once or more in a year <input type="checkbox"/> Once in 5 years <input type="checkbox"/> Once in 10 years <input type="checkbox"/> Max record: date ___/___/___ ..... Height (m) .....days <input type="checkbox"/> Landslide <input type="checkbox"/> Others: <input type="checkbox"/> No information
5.2 Disaster situation	Please specify what had happened when the above disaster occurred?

**6- Identification of Hazard:**

- The potential of disasters with the cause of natural conditions above the design conditions (extreme conditions) are checked and confirmed by this Question. The project can be blocked due to the potential disaster situations such as inundations by flood water, soil masses by landslides, road related structural failures or any other reason.
- In addition to blocking the road, damages to the road can also be happened. Therefore, potential damages to the road and the surrounding area is checked & confirmed. Landslide (slope failures), flood inundations, structural failures (due to over capacity) or other possible situations are confirmed.
- With the identification of the above conditions and the potential hazardous locations, a map showing those potential locations is developed (attached as Attachment 05). This

map is developed using the map 02 prepared in Checklist Form A. It needs to mark the potential location of the hazards which are recognized by the information from, inspector, residents etc. The map can prepare using CAD or hand drawings.

6.1	Which kind of disaster potential exists in this project area? Please mark all that apply.				
	Condition	Landslide (Slope failure)	Flood	Structural failure/ over capacity	By others reason (_____)
	The road can be blocked by;	<input type="checkbox"/>	<input type="checkbox"/>	<input type="checkbox"/>	<input type="checkbox"/>
	The road can be broken by;	<input type="checkbox"/>	<input type="checkbox"/>	<input type="checkbox"/>	<input type="checkbox"/>
	The surrounding area can be damaged by;	<input type="checkbox"/>	<input type="checkbox"/>	<input type="checkbox"/>	<input type="checkbox"/>
*Please specify any other possible situation;					
6.2	Please mark above potential hazardous areas on the Map 02 "Road plan map" prepared by form A.				
				⑤ Attached <input type="checkbox"/>	

**7- Countermeasures:**

- Relevant to the arrangements of countermeasures, it is necessary to confirm about the related, associated fulfillment of the project. It is checked and confirmed by Question no. 07. Periodic Inspections are essential to be arranged in road management stages. Such arrangements help to confirm whether the inspection plan has been arranged or not. For any special inspections, one or more criteria will be considered to decide such inspections. Those are (1). More rainfall above the decided level (2). Warnings are issued by Department of Meteorology and NBRO (3). Identified at Inspection Screening (this step is conducted during the maintenance stage using Form C) and (4). Informed by road users or neighborhood residents. This confirmation of inspection arrangement is useful as a standardized arrangements for checkups using Checklist Form C in maintenance stage (In-Service) and (4). Information is provided by road users or neighborhood residents.

7.1 Inspection as road management	Periodical checkup will be planned;    Annually <input type="checkbox"/> Monthly <input type="checkbox"/> Weekly <input type="checkbox"/> Daily <input type="checkbox"/>
	A special inspection will be done in case of ; More than _____mm rainfall <input type="checkbox"/> Warning from MOD and NBRO <input type="checkbox"/> Required by inspection screening <input type="checkbox"/> Information by users or neighborhood residents <input type="checkbox"/>

- In case of extreme situations, traffic control will be decided based on certain criteria. This may be one or more conditions such as continuous rainfall, high rainfall intensity, wind velocity, visibility and any other highly considerable criterion.
- As an early warning to road users, different arrangements can be utilized such as Sign Boards, Public Notices, Media Announcements, Guide by Traffic Police etc.
- Action Plans on emergencies for relevant organizations are important for prompt and clear responses. Collective Action Plans are essential to be prepared by responsible agencies for road operations such as RDA, PRDA, Police, Local Authorities, Disaster

Management and other relevant partners. Action Plan can be a common. Agency-wise plans can also be arranged.

- Availability of alternative routes for the road users are confirmed by the checklist. Here, the availability of alternative routes may be; (1). Exists, (2). Temporary construction of the road construction process, and (3). Not prepared (not exist).
- Once a disaster damage happened, immediate renovation and restoration of the road is needed. If a restoration plan consisting of each procedure has been prepared for the project, it is effectively helpful in immediate actions. Therefore, it needs to confirm by the checklist whether such plan has been prepared or not by relevant authorities (RDA, PRDA, Local Authorities).

7.2 Traffic control	Prepared criterion value for traffic control; Continuous rainfall <input type="checkbox"/> Rainfall intensity <input type="checkbox"/> Wind velocity <input type="checkbox"/> Visibility <input type="checkbox"/> Other criteria <input type="checkbox"/> _____
	Early warning mechanism; Sign board <input type="checkbox"/> Public Notice <input type="checkbox"/> Media Announcement <input type="checkbox"/> Guide by traffic police <input type="checkbox"/> Others <input type="checkbox"/> _____
	Action plans for relevant organizations on emergencies prepared with / by; RDA <input type="checkbox"/> PRDA <input type="checkbox"/> Traffic police <input type="checkbox"/> Executive engineers <input type="checkbox"/> Local authority <input type="checkbox"/> DMC <input type="checkbox"/> DDMCU <input type="checkbox"/>
	Alternative route; Exist <input type="checkbox"/> Prepared temporary road construction procedure <input type="checkbox"/> Not prepared <input type="checkbox"/>
	Restoration plans of road; Prepared the procedure <input type="checkbox"/> Not prepared <input type="checkbox"/>

- In case of unexpected conditions, evacuation mechanism for road users as well as people in the neighborhood has to be considered. An evacuation mechanism for road users consists of different components. The system may have warning and announcement arrangements, determined evacuation routes, existence of guidance, arranged parking facilities, availability of food and water supplies. For the neighborhood, warning and announcement arrangements, determined evacuation routes, existence of guidance and coordinating arrangements based on the local disaster management plan may be prepared. By the checklist, it is checked whether one / more of those arrangements are considered or not.

7.3 Evacuation	Evacuation systems for users Warning <input type="checkbox"/> Evacuation route <input type="checkbox"/> Guide <input type="checkbox"/> Evacuation center <input type="checkbox"/> Parking lot <input type="checkbox"/> Food <input type="checkbox"/> Water <input type="checkbox"/> Announcement system <input type="checkbox"/>
	Evacuation system for neighborhood Warning <input type="checkbox"/> Evacuation route <input type="checkbox"/> Guide <input type="checkbox"/> Evacuation center <input type="checkbox"/>
	Coordination with the local disaster management plan <input type="checkbox"/>

- The arrangements to get the cooperation of related organizations as well as the community are checked and confirmed with the considered disaster associated contexts. With the discussions among relevant organizations by RDA, it needs to confirm the status

of agreement on possible disasters, traffic control plans, site inspection plan, restoration system and the cooperation with the relevant organization in emergencies.

- In case of community side concerns, it is checked and confirmed whether they were aware of possible disasters along the road, proposed / arranged warning, evacuation mechanism and disaster management plan with local authorities.

7.4 Cooperation	Relevant organizations agreed with;						
		Traffic police	Local Authority	NBRO	UDA	DMC	
	Possible disasters						
	Traffic control plan						
	Inspection plan						
	Restoration system						
	Cooperation of disaster situation						
	Communities have been explained;					Yes	No
	Possible disaster						
	Warning system						
	Evacuation system						
	Disaster management plan with LA						

**8- Confirmation of Monitoring in Construction Stage:**

- The monitoring arrangement during the road construction period is checked and confirmed by Question No. 08. Existence of construction plans and associated disaster management plan, reply-restoration-revision systems, confirmations with the neighborhood and arrangement of focal points to the public complaints are checked and confirmed by the questions from 8.1 to 8.5

8.1	Had Construction plan been prepared?	Yes	No
8.2	Is the construction plan included the disaster management plan?	Yes	No
8.3	Is it prepared any reply system against any problem?	Yes	No
8.4	Had the construction plan been explained to the neighborhood residents/ communities?	Yes	No
8.5	Have the contact person been announced to the residents / community?	Yes	No

## Manual for Checklist Form C

### **CHECKLIST FORM C - SCREENING:**

- The Form Checklist C for Screening is used to check the hazardous conditions along the road during operational stage. The screening is not an in depth, detailed study (compared to inspection of the road) and therefore, advanced geological, flood control expertise related to the sites is not expected from the RDA officials. The form has been arranged for Road development related officials (EE) and relevant technical officials.
- This is conducted in periodical schedule by the officials responsible for maintainance such as Excecutive Engineers or Local Authorities. Technical officer (referred as “Inspector”) assigned by Excecutive Engineer will do the checkup by site visits. He/She needs to check all structures (including earth works), earmark the hazardous locations and record in Checklist Form C for Screening.
- After screening completed by the nominated technical officer (referred as “Inspector”) by Executive Engineer, Evaluation under Question B in Checklist Form C for Screening is done for the screened sites by the Executive Engineer (Question B3 & Question B4). At the evaluation, he/she earmarks the relevent technical agency to call for technical inspections (Column 02) and site-specific facts to be considered (Column 03) based on the facts identified by Screening and Evaluation at the end of Screening by Inspector. The sites recommended for Inspection by the Inspector’s evaluation are considered for the evaluation by Executive Engineer. After evaluation confirmed, completed Checklist Form C for Screening is submitted to the Chief Engineer for further actions.
- If the Screening identifies the need of inspection for a specific site/s, then, the request is made to do the investigation by the relevant technical agency. For that, the technical agency uses the Checklist for Inspection or their own format. The relevant Technical agency provides the investigation with recommendations to Chief Engineer. Based on the Inspections, a summary report is sent to the Director, Maintainance, Management and Construction Division, RDA Head Office through Provincial Director, RDA.
- The instructions for completing Checklist Form C for Screening are given as following manner.
- A draft map of the road/sections of the sites needs to provide in the given box, under the Question A1 of Checklist Form C for Screening. Simultaneously, the exact location numbers are marked on the draft map. At the same time, the locations of the above sites are written on the line of Question A2. As the referance and supplimentary documents, Map in Form B (referred as Attachment 05 in Checklists Form B and Table of the locations).



- Question No. 1.0 (from 1.1 to 1.7) is the screening questions for the each site to be completed by Inspector after site visits.
- Site identification is done using the standard identification system used by RDA including kilometers with location side (left hand side (LHS) or right hand side (RHS)).
- Screening can be done in one or several days. Accordingly, the dates need to be mentioned in this section.
- The sites can be identified with the natural features or constructed structures such as natural slope, retaining wall etc. Such site-specific features provide an initial understanding for the evaluation. One or more applicable feature/conditions can be marked in the relevant spaces of the checklist.

Road structure related to the site:

(1) Natural slope	<input type="checkbox"/>	(6) Drainage/ Canals	<input type="checkbox"/>
(2) Cut slope	<input type="checkbox"/>	(7) Road surface	<input type="checkbox"/>
(3) Embankment	<input type="checkbox"/>	(8) Others: Description : ..... (Such as Utility Services (Power, Water, Telecom etc.) Level Crossings, Tunnels, Subways, Electricity/ Telecom Posts etc.)	<input type="checkbox"/>
(4) Retaining wall	<input type="checkbox"/>		
(5) Bridge / Culverts	<input type="checkbox"/>		

- According to the observable signs of the site, potential hazardous situations at extreme conditions can be presumed by the Inspector and recorded in the Question No. 1.4.

Observable signs / features of the site, which may lead to hazardous / extreme conditions:

(1) No problem. Good condition	<input type="checkbox"/>	
(2) Soil and Concrete condition	<input type="checkbox"/>	
(3) Collapse (broken) and crack	<input type="checkbox"/>	
(4) Road surface condition	<input type="checkbox"/>	
(5) Drainage structure condition / Cleaning condition (like blockage)	<input type="checkbox"/>	

- Question No. 1.4.2: The land use types of the project site are basically confirmed with types of breakdowns as following categories such as “Developed area, Not Developed area, Residential, Commercial, Plantation and Other etc”. It will be supportive in confirmation of hazardous potential areas.
- The condition of the above signs and their status of potential failures (mentioned in Question No. 1.4.1) need to be described in the space at Question No. 1.5.
- Hand- drawn Sketch of the site needs to be done by the Inspector using appropriate scale and standard symbols at Question No. 1.6.

- Two site photographs that describe and show the situation more clearly need to be attached with some details Question No. 1.7.
- At the end of the each site related check sheets, the Evaluation by the Inspector needs to be completed referring the need of Inspection and the category of failure. It is useful for decisions for prioritized actions for inspections. For example, Executive Engineer can select the sites with “Need” response for inspection requests. Further, he/ she can sort the sites to relevant technical agencies for inspections, according to the “type of failures”.

Evaluation

01. Needs of inspection:            Need             No Need

02. If it is checked “Need” at 01, please check the type of potential failure

(1) Rock fall / collapse	<input type="checkbox"/>	(6) Retaining wall failure	<input type="checkbox"/>
(2) Cut Slop failure / collapse	<input type="checkbox"/>	(7) Culvert /canal/ drainage failure	<input type="checkbox"/>
(3) Landslide	<input type="checkbox"/>	(8) Pavement	<input type="checkbox"/>
(4) Debris flow	<input type="checkbox"/>	(9) Problem of bridge	<input type="checkbox"/>
(5) Embankment failure	<input type="checkbox"/>	(10) Others / Not sure	<input type="checkbox"/>

- After filling the Questions from No. 1.1 to 1.7, the Inspector signs and confirms the content of the form relevant to each site. Then, his/her evaluation for inspections is filled and submitted to Executive Engineer after filling of some sections of the cover letter (first Page i.e. Question A: Basic Information (Questions A1 & A2 can be filled by Inspectors).

**CHECKLIST FORM C - INSPECTION:**

- With the request from RDA, the relevant technical agency/ies will do the inspection using relevant Inspection Sheet of Checklist Form C specifically arranged for road sector inspections. There are three Checklist formats of Inspections for Landslides, Inundations and Damages to structures on the road. (See attachments). Those attached Inspection Sheets are as a guideline (Examples) for technical agencies. Inspection sheets can be developed and used by relevant technical agencies, according to the requirements.

**CHECKLIST FORM C - DISASTER RECORDS:**

- The Checklist Form C on Disaster Records is more similar to the Checklist Form C - Screening. The checklist is used when a disaster occurs, to check and record the each disaster situation related to the road.
- In this Checklist Form C for Disaster Records, the differences from the Checklist Form C for Screening are as follows;
  1. In Question A:- In the section on Basic information of the road, sub section (f) requests recorded date/s of the disaster. In this case, the date/s of disaster occurred need to be recorded, not the reported date/s.
  2. Question A.1:-Draft map of examined site with location numbers: The site/s of disaster recorded along the road. Here, the locations of disaster events need to be highlighted.
  3. Question B:-Evaluation of the damaged sites: Some possible examples for Column 02 are slope failures, debris flow, inundation, rockfalls etc. In Column 04, the site observation remarks, specific features need to be reported by the Inspector.
  4. Questions Nos.1.0 to 3.0, with sub sections are applicable to check and report by Inspector related to the disaster event.

Those questions that are differing from Screening are as follows;

Question No. 2.0: includes details of the disaster condition

Question No.2.1: includes what was the event occurred. The event may be landslide, slope failures, rock falls, embankment failures, inundation etc.

(2.1) What was the event occurred.	1). Landslides 2). Inundation of the road 3). Road structural failures 4). Damages to surrounding area 5). Others	<input type="checkbox"/> <input type="checkbox"/> <input type="checkbox"/> <input type="checkbox"/> <input type="checkbox"/>
---------------------------------------	---	--

5. Question No.2.2: Weather condition that led to the disaster situation is expected in this section. The weather condition for the disaster situation may be continuous rainfall, rainfall intensity, high winds, cyclones etc. Among them, if observed the rainfall is continuously for days, it can be recorded. If Rainfall intensity records are available, it also can be written.
6. Question No.2.3: Duration of traffic interruption is the total (approximate) impassible duration of road use due to the blocking of roads by the disaster condition.

(2.2) Weather conditions that led to the disaster situation	1). Continuous rainfall 2). Heavy rains 3). Strong winds 4). Cyclone 5). Others (      )
(2.3) Duration of traffic interruption	..... Days

7. Question No. 2.4: Description of the damage in brief is needed along with the condition of the failure.

8. The extent of damages is recorded in Question No. 3.0 by the Questions 3.1 to 3.4. Question No. 3.1: Damaged physical structures - destruction of different road structural types may be possible with the disaster events. Some of those have been enlisted in the section. Those identified damaging structures need to be marked in the list accordingly.

Damaged physical structures:

(1) Natural slope	<input type="checkbox"/>	(6) Crossing the culvert / canal	<input type="checkbox"/>
(2) Cut slope	<input type="checkbox"/>	(7) Road surface	<input type="checkbox"/>
(3) Embankment	<input type="checkbox"/>	(8) Others	<input type="checkbox"/>
(4) Retaining wall	<input type="checkbox"/>	Description :	
(5) Bridge	<input type="checkbox"/>		

9. Question No. 3.2: Size of the damage - specifying the damage size by necessary items is expected in the question. Damages to the structures can be expressed in different parameters. They may be height, width, length, depth and/or radius. Those are used accordingly to the type of damaged structure and damaged extent.

The size of the damage: Please specify the damage size choosing necessary items.

(1) Width	<input type="checkbox"/>	_____m
(2) Height	<input type="checkbox"/>	_____m
(3) Length	<input type="checkbox"/>	_____m
(4) Size of Culvert / canal	<input type="checkbox"/>	_____m × _____m or R= _____m
(5) Others	<input type="checkbox"/>	Description :

10. Question No. 3.3: Condition of failure means the degree of impacts on the road. This may vary from 0% (No damage of road structure) to 100% (Destroyed Completely). There are 02 other in between choice options. Those are (1). Though the road structure functions, repair is needed (2). Though the structure has not destroyed, the function has lost. Based on the inspector’s observations, the response may be decided.

Condition of failure:

(1) No damage of road structure	<input type="checkbox"/>
(2) Though the road structure functions, repair is needed.	<input type="checkbox"/>
(3) Though the structure has not destroyed, the function has lost.	<input type="checkbox"/>
(3) Destroyed Completely	<input type="checkbox"/>

11. Question No. 3.4: Photos of the Site - Two photographs of the damaged site illustrating the extent of the damages with clear details need to be attached with a brief comment on each.

## Manual for Checklist Form D

- Checklist Form D is used to record the public concerns on the disaster impacts related to the project sites. The checkups using the checklist are done by District Disaster Management Coordinating Units. Once there was a disaster happened related to the road development, Assistant Director or assigned officer of the District Disaster Management Unit visits the site, record the disaster situation and public concerns using the Checklist Form D. The issues and required actions based on the findings by Checklist will be discussed at District Disaster Management Committee meeting with the participation of relevant agency representatives (RDA, PRDA, UDA, Local Authorities, and Agrarian Services etc.). Based on that, required actions will be taken by inter agency coordination. Brief final reports on actions taken and recommendations will be submitted to DMC and MMC Division, RDA.

- The contents in the Checklist Form D are described as follows;
- Question No. 01 stands for basic information of the road. It consists of name of the road, road class and identification reference number, responsible agency for the road (RDA or PRDA) Administrative Executive Engineer Division related to the problem sites, disaster damaged location details with exact landmarks.

Project / Road Details:

1.1	Name of Road:
1.2	Class of the Road: E/A /B / C / Other
1.3	Road Reference No:
1.4	Responsible Agency of the Road Administration:
1.5	Area / Location of the problem exists: Between ..... Km - ..... Km
1.6	Responsible Office of the problematic section of the road:
1.7	Exact Landmarks (if any): Please attach a sketch map

- Question No.02 is required for confirming the details of responsible officer for Checklist form D. Basically, the responsible officer is Assistant Director, DDMCU of relevant district.

Information of responsible DDMCU

2.1	Name of responsible officer from DDMCU :		
2.2	Position :		
2.3	Organization :		
2.4	Postal Address:		
2.5	Telephone : Office;	Mobile;	Fax;

- Disaster related information is recorded by Question No. 03. Questions 3.1 to 3.9 are the details of the Interviewer (or site inspector from DDMCU) and location details.

Organizer of the Interview means, the coordinator of village communities with DDMCU regarding the situation. Mostly, GN officer represents this.

Disaster Information

3.1	Interview date	
3.2	Organizer of this interview	
3.3	Interviewer	
3.4	Name of Province	
3.5	Name of District	
3.6	Name of DSD	
3.7	Name of the LA / MC/ UC	
3.8	Name of GND	
3.9	Name of Village / Community/ Lane	

- Question No. 3.10 to 3.17 collects details of the disaster situation and related information. In these records, the situation happened would be the basis.

3.10	Date/s occurred (disaster)	
3.11	Type of disaster	
3.12	Duration of the event	Days
3.13	Affected area	Ac / Ha/ Sq.M. / Sq. Km
3.14	Affected number	Family:                      People: Properties: Housing Units ( ); Vehicles ( ); Roads ( ); Livestock: ( ); Canals / Dams: ( ); Other (Specify )
3.15	Disaster management plan for the GND	1. Exist                      2. Not exist
		1. Functioned              2. Not functioned: Reason
3.16	Evacuation	1. Needed                      2. Not needed
3.17	Evacuation period (No. of Days/ Hours stayed outside due to the event)	Days

- The interview contents are taken through discussions with the officers or community members regarding the situation, evacuation arrangements, expected support of the community and the cause of disaster. These contents are required in details for clear understanding of the situation. Sometimes, the situation may be or may not be due to a reason related to the road, though the road and neighborhood got affected. Those matters need to be carefully observed by the Inspector.

Interview contents

4.1. Situation
4.2. Evacuation
4.3. Which kind of support was needed?
4.4. Cause of the disaster
4.5 Others (Remarks)

- According to the interview findings, DDMCU needs to comment on the situation with recommendations for actions. Question No. 05 relates to those points. Facts and confirmations expected under question 05 are the level of priority for actions based on the seriousness of the impact (Q5.1 & 5.2) and necessary actions recommending by DDMCU based on the public concerns (Q5.3). According the Question 5.4, each of the proposed necessary actions will be further elaborated based on the contents in the request, responsible agencies to be dealt with and the purpose of the request (justification).

DDMCU comment

5.1	Situation	1. Very serious	2. Serious	3. Not serious
	Reason			
5.2	Needs of response	1. Very urgent	2. Urgent	3. Not Urgent
	Reason			
5.3	Necessary action	Activity recommended by DDMCU		Ranking based on significance
		1.		3
		2.		1
		3.		2
5.4	Request Action 1	1. Contents: 2. Organization to request: 3. Purpose to request:		
	Request Action 2	1. Contents: 2. Organization to request: 3. Purpose to request:.		
	Request Action 3	1. Contents: 2. Organization to request: 3. Purpose to request:		
5.5	Comment / Additional facts:			



## PROCEDURE OF FORM A & B

(\*\*\*\*\*Road)

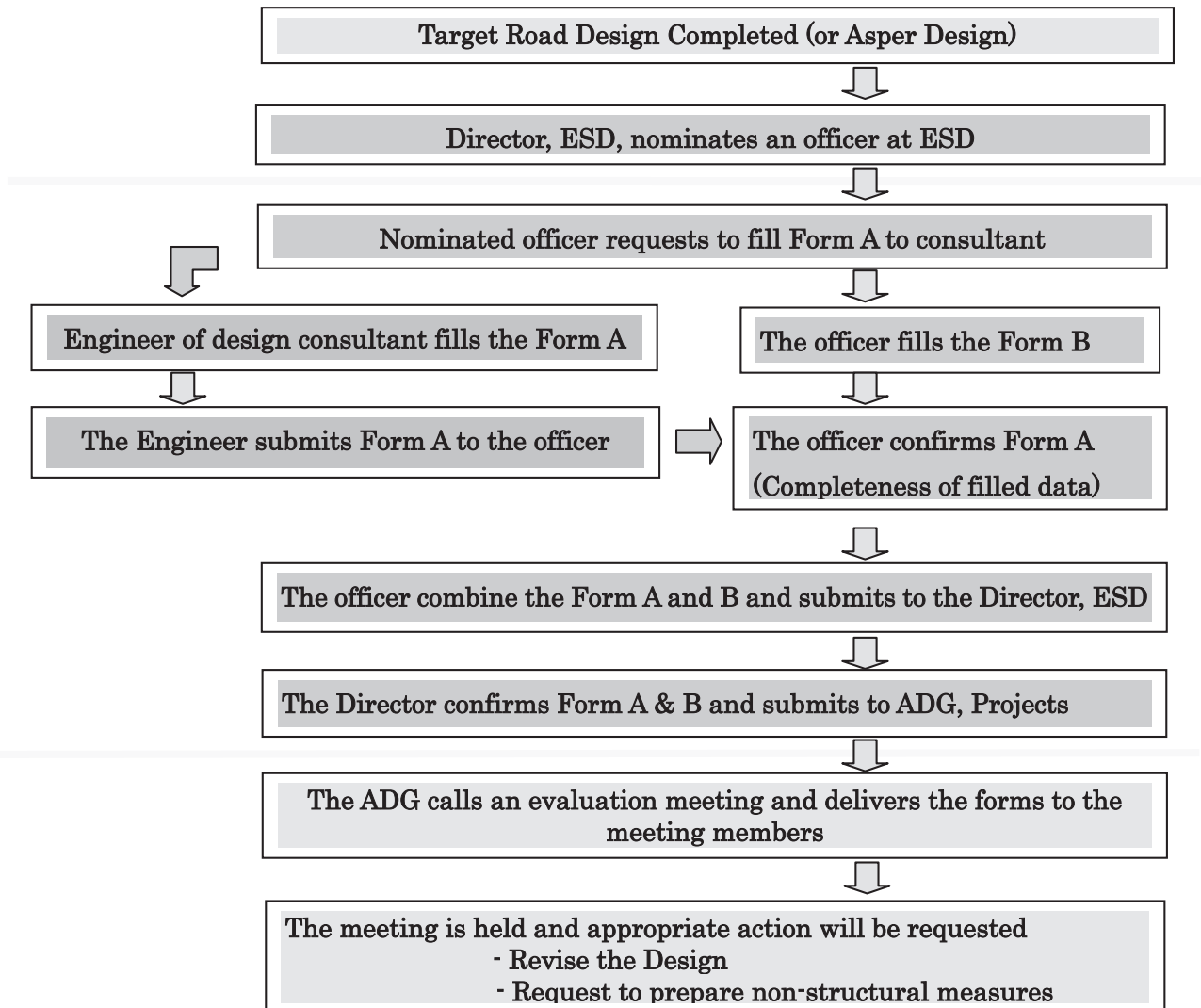

**PROCEDURE OF FORM C (SCREENING & INSPECTION)**

**\*\*\*\*\* Road**

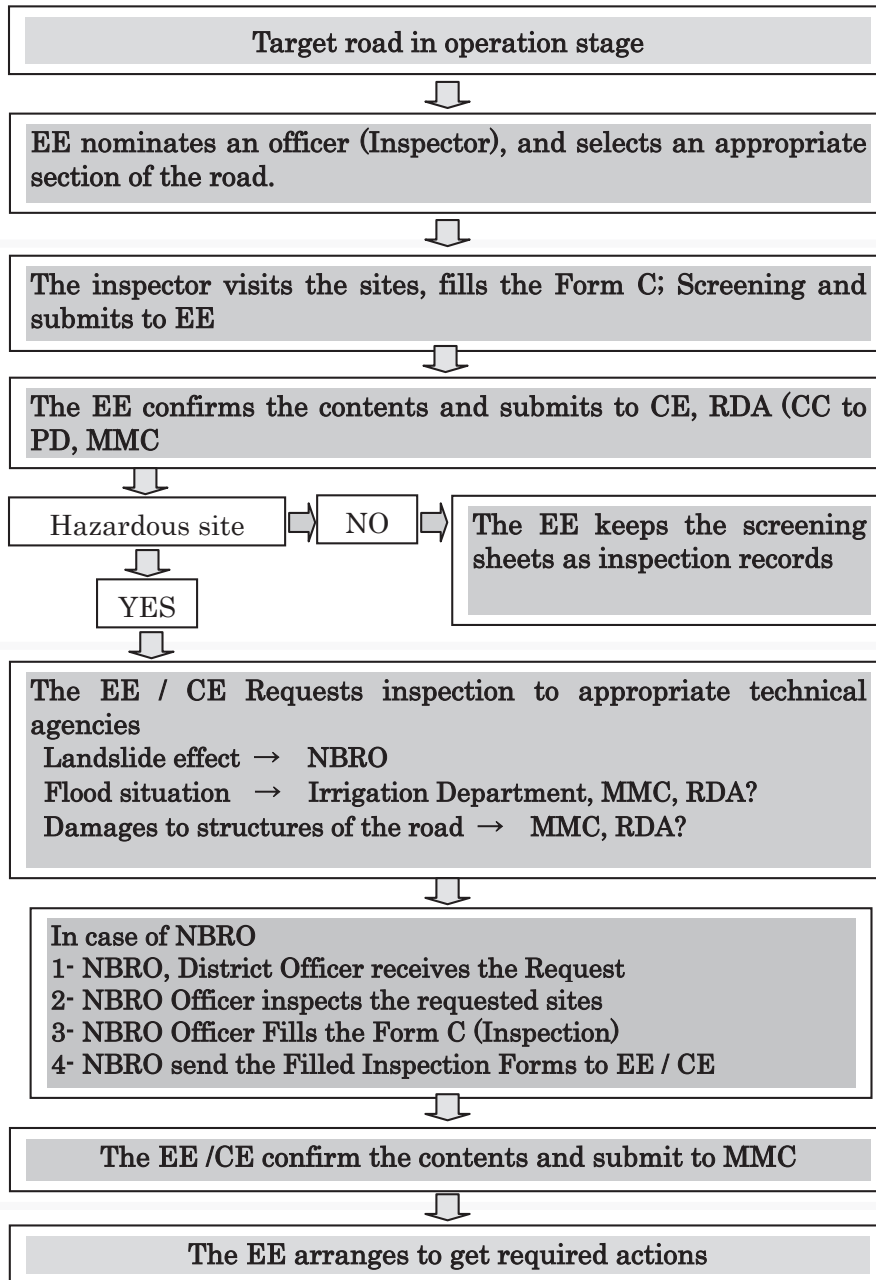

**PROCEDURE OF  
FORM C (DISASTER RECORDS) & FORM D**

**\*\*\*\* Road**

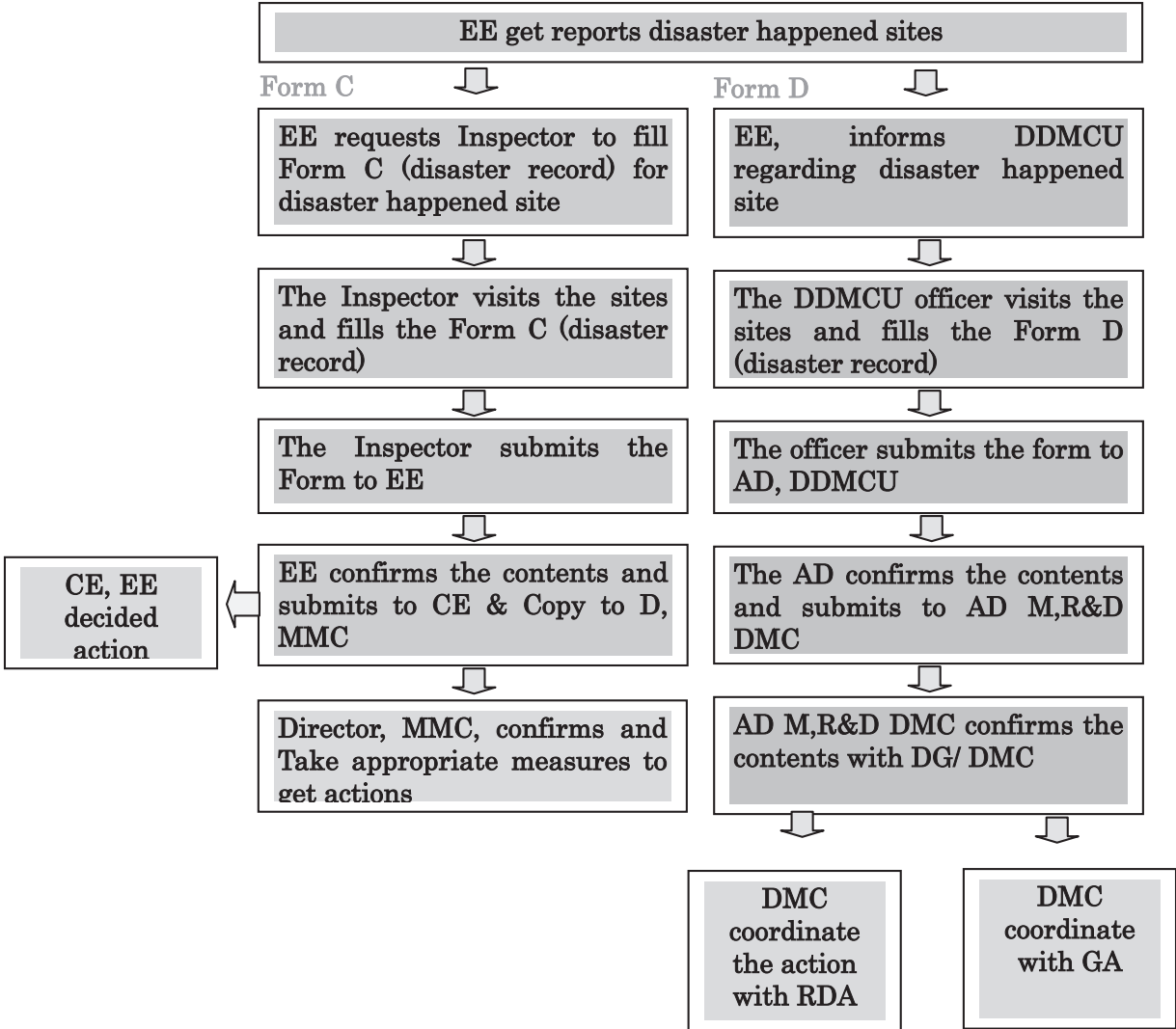



Sample



## Checklist Forms A & B : Disaster Impact Assessment

### Basic Information of the Road:

- a. Name of the Road: **75+500km to 86+500km section of Avissawella – Hatton – Nuwara Eliya Road**
- b. Route No / Code: **A007**
- c. Category of Road: **National**
- d. Road Classification: **A**
- e. Location of the project: Province: **Central**  
     CE division: **Nuwara Eliya**  
     EE Divisions: **Norwood (75+500 – 85+000km) and Nuwara Eliya (85+000km – 86+500km)**  
     Please refer to location map attached in annexure 1
- f. The length of the road section: **11+000km**
- g. Type of Project: **Widening & Improvement / Rehabilitation of the existing road**

Form A Map 01	Route Map (Location Map)	① Attached in Annexure 1	Not prepared <input type="checkbox"/>
Form A	Checklist	Completed ✓	Not Completed <input type="checkbox"/>
Form A Map 02	<u>Road Plan</u> with structures, hazardous & conservation area	② Attached in Annexure 2	Not prepared <input type="checkbox"/>
Form A Table01	List of <u>Road Structures</u>	③ Attached in Annexure 3	Not prepared <input type="checkbox"/>
Form A Map 03	<u>Road Plan</u> with drainage network of the road	④ Attached in Annexure 4	Not prepared <input type="checkbox"/>
Form B	Checklist	Completed ✓	Not Completed <input type="checkbox"/>
Form B Map 04	<u>Potential hazardous areas</u>	⑤ Attached in Annexure 5	Not prepared <input type="checkbox"/>

### Details of the Resonsible Official (for RDA, Director (ESDD)):

Name of Officer		S.H.U. De Silva	
Designation		Director	
Division & Organization		Environmental and Social Development Division, Road Development Authority	
Contact Details	Telephone	Office	0112862470
		Mobile	0773318536
		Fax	0112862443
Email Address		hudsondesilva@yahoo.com	

Signature: \_\_\_\_\_

Name : \_\_\_\_\_

Date: \_\_\_\_\_

Received by: ADG (Projects), RDA

Signature of \_\_\_\_\_

Name : \_\_\_\_\_

Date : \_\_\_\_\_

<b>FORM A</b>
---------------

**1. Information of Design Standard:**

1.1	Name of Overall Design Standard :	
1.2	Standards / Guidelines applied on following works :	
	Type of work	Name of Standards / Guidelines
	Cuttings of slopes	<b>Project specific (RDA – ICTAD Provisions) &amp; NBRP recommendations</b>
	Fillings of lowlands	<b>Not applicable</b>
	Embankment works	<b>RDA Specifications</b>
	Retaining walls / Side walls	<b>Project specific (to suit site condition)</b>
	Prevention of Slope failures	<b>NBRO recommendations</b>
	Drainage System	<b>Improve existing drainage (Lined drains)</b>
	Structures crossing the road	
	Bridges / Tunnel / Viaduct	<b>RDA bridge design manual</b>
	Culverts	<b>RDA bridge design manual</b>
	Geometry	<b>RDA road design guidelines</b>

**2. Information of Design Parameters:**

2.1	Please attach <u>Route map (Location map)</u> <b>Road section from ch. 75+500 to 86+500</b>	
Natural condition and other Societic conditions	① Attached <input checked="" type="checkbox"/> ( <b>annexure 1</b> )	
	Climatic Division/s; Wet Zone <input checked="" type="checkbox"/> Intermediate Zone <input type="checkbox"/> Dry Zone <input type="checkbox"/>	
	Rainfall value considered for the design: <b>29.63mm 177.8 mm/h</b>	
	Annual Average <input checked="" type="checkbox"/> Record Max <input type="checkbox"/> Recently Max <input type="checkbox"/> Others <input type="checkbox"/> _____	
	Just follow the standard <input type="checkbox"/> Not discussed <input type="checkbox"/>	
	Features of the location ; Mark all that apply	
	Flat land <input type="checkbox"/> Hilly area <input checked="" type="checkbox"/> Mountain area <input checked="" type="checkbox"/> Coastal area <input type="checkbox"/> Urban area <input type="checkbox"/> Rural area <input checked="" type="checkbox"/> Suburban area <input checked="" type="checkbox"/> Others <input type="checkbox"/> _____	
Remarked public facility along the road; <b>Kotagala railway station (77+500), Kotagala hospital (80+730)</b>		
Events or festivals considered for the design: No <input type="checkbox"/> Yes <input checked="" type="checkbox"/> ( <b>Viewing points of St. Clair and Devon waterfalls</b> )		

Fill in the decided values in the design. If they comply with the standards listed above in 1.1 and 1.2, please mark “Yes”. If not, please mark “No” and specify the reason.

2.2 Design Conditions	Design Speed	<b>30 Km/h</b>
	Design Traffic Volume	<b>2300 ADT/day</b>
	Probable Rainfall Return Period and Rainfall Intensity	
	- Rivers	<b>100 years 279.4 mm/h</b>
	- Streams	<b>50 years 228.6 mm/h</b>
	- Canals	<b>50 years 228.6 mm/h</b>



2.3 Vehicle Restrictions	Design Vehicle	Passenger Car <input checked="" type="checkbox"/>	Typical Heavy Truck <input checked="" type="checkbox"/>		
		Others <input type="checkbox"/>	Semi-trailer <input checked="" type="checkbox"/>		
	Load Restriction		t	Yes	No <input checked="" type="checkbox"/>
	Vehicle Class	<b>All classes</b>			

### 3. Design Policy for Route Selection

3.1	Please specify the reason of emphasis of route selection: <b>Original route used with few improvements on curved areas.</b>
3.2	Recognized hazard along the selected route: Not recognized or considered <input type="checkbox"/> Landslide <input checked="" type="checkbox"/> Slope Failures <input checked="" type="checkbox"/> Flood <input type="checkbox"/> Heavy Rain <input checked="" type="checkbox"/> Strong Wind <input type="checkbox"/> Tsunami <input type="checkbox"/> Others:
3.3	Please specify the main countermeasures to response the above hazard; <b>Landslides and Slope failure: Change alignment (e.g. 84+500), reduce cut slope angle (1:2 or 1: 1.5) &amp; NBRO Recommendations.</b> <b>Heavy rains: Improve road side drainage with lined drains and use of 900 mm pipe culverts.</b>

### 4. Hazards /Conservations along the road

Please prepare the road design plan with hazard area and conservation area.

4.1	Please prepare map data below. Please mark hazard is exist or not along the road. If "Exist", please mark the area data is exist or not.	Hazards exist along (near) the road? Y/N	In case of exist hazard, data available? Y/N
	- Landslide hazard area / Hilly terrains	<b>Yes</b>	<b>Yes</b>
	- Area more than 30 degree slope	<b>Yes</b>	<b>No</b>
	- Flood hazard area or Recorded flood area	<b>No</b>	<b>No</b>
	- Crown Land Reservation	<b>Yes</b>	<b>No</b>
	- Natural Forest Reserves / Strict Nature Resereves	<b>No</b>	<b>No</b>
	- Coastal Conservation areas / Tsunami affected areas	<b>No</b>	<b>No</b>
	- Wetlands / Marshy land areas / Sanctuaries	<b>Yes</b>	<b>No</b>
	- Other designated conservation area (Archeological/ Cultural)	<b>No</b>	<b>No</b>
4.2	Did you prepare drawing plan of drainage system?	Yes <input type="checkbox"/> No <input checked="" type="checkbox"/>	
4.3	Please prepare a map with above data and <u>road plan</u> with location of the structures. ②Attached (annexure 2)		
4.4	Please prepare a table* of <u>road structures</u> and structure measures considerations. ③Attached (annexure 3)	<input checked="" type="checkbox"/>	
4.5	Please attach a map of <u>Road plan</u> with Drainage network of the road (annexure 4)	④Attached <input checked="" type="checkbox"/>	

### Details of the Responsible Design Engineer of Form A

Name of Design Engineer		Design for the particular road section was carried out by a design consultant	
Designation			
Division & Organization			
Contact Details	Telephone	Office	
		Mobile	
		Fax	

	Email Address	
--	---------------	--

Signature of Design Engineer: \_\_\_\_\_

Name of Design Engineer : \_\_\_\_\_

Date: \_\_\_\_\_

**FORM B**

**5. Disaster Experience in the Project Area**

5.1 Disaster records	Which kind of disaster experience had in the project area shown on map <input type="checkbox"/> Inundation    Once or more in a year <input type="checkbox"/> Once in 5 years <input type="checkbox"/> Once in 10 years <input type="checkbox"/> Max record; date ___/___/___ ..... height (m) .....days <input checked="" type="checkbox"/> <b>Landslide</b> <input type="checkbox"/> Others: <input type="checkbox"/> Land Subsidence <input type="checkbox"/> No information
5.2 Disaster situation	Please specify what had happen when the above disaster occurred? <b>Flow of traffic was temporary disturbed</b>

**6. Identification of Hazard:**

6.1	Which kind of disaster potential exists in this project area? Please mark all that apply.																				
	<table border="1" style="width: 100%; border-collapse: collapse; text-align: center;"> <thead> <tr> <th style="width: 30%;">Condition</th> <th style="width: 15%;">Landslide (slope failure)</th> <th style="width: 15%;">Flood</th> <th style="width: 20%;">Structure failure/ over capacity</th> <th style="width: 20%;">By others reason (_____)</th> </tr> </thead> <tbody> <tr> <td>Road can be blocked by;</td> <td><input checked="" type="checkbox"/></td> <td><input type="checkbox"/></td> <td><input type="checkbox"/></td> <td><input type="checkbox"/></td> </tr> <tr> <td>Road can be broken by;</td> <td><input checked="" type="checkbox"/></td> <td><input type="checkbox"/></td> <td><input type="checkbox"/></td> <td><input type="checkbox"/></td> </tr> <tr> <td>Surrounding area can be damaged by;</td> <td style="background-color: #cccccc; text-align: center;">/</td> <td style="background-color: #cccccc; text-align: center;">/</td> <td><input type="checkbox"/></td> <td><input type="checkbox"/></td> </tr> </tbody> </table>	Condition	Landslide (slope failure)	Flood	Structure failure/ over capacity	By others reason (_____)	Road can be blocked by;	<input checked="" type="checkbox"/>	<input type="checkbox"/>	<input type="checkbox"/>	<input type="checkbox"/>	Road can be broken by;	<input checked="" type="checkbox"/>	<input type="checkbox"/>	<input type="checkbox"/>	<input type="checkbox"/>	Surrounding area can be damaged by;	/	/	<input type="checkbox"/>	<input type="checkbox"/>
Condition	Landslide (slope failure)	Flood	Structure failure/ over capacity	By others reason (_____)																	
Road can be blocked by;	<input checked="" type="checkbox"/>	<input type="checkbox"/>	<input type="checkbox"/>	<input type="checkbox"/>																	
Road can be broken by;	<input checked="" type="checkbox"/>	<input type="checkbox"/>	<input type="checkbox"/>	<input type="checkbox"/>																	
Surrounding area can be damaged by;	/	/	<input type="checkbox"/>	<input type="checkbox"/>																	
	*Please specify any other possible situation;																				
6.2	Please mark above <u>potential hazardous areas</u> on the Map 02 “Road plan map” prepared for Form A. ⑤ Attached ✓ (annexure 2)																				

**7. Countermeasures**

7.1 Inspection as road management	Periodical checkup will be planned;    Annually <input type="checkbox"/> Monthly <input type="checkbox"/> Weekly <input type="checkbox"/> Daily ✓ <input type="checkbox"/> (Executive Engineer (EE) is responsible for routine monitoring of the particular road section) Special inspection will be done in case of ; More than _____mm rainfall <input type="checkbox"/> Warning from DOM and NBRO <input type="checkbox"/> Required by inspection screening <input type="checkbox"/> Information by users or neighborhood residents <input type="checkbox"/> EE and his team is carrying out regular inspections to land slide prone areas especially during heavy rainfall periods
7.2 Traffic control	Prepared criterion value for traffic control; Continuous rainfall <input type="checkbox"/> Rainfall intensity <input type="checkbox"/> Wind velocity <input type="checkbox"/> Visibility <input type="checkbox"/> Other criteria <input type="checkbox"/> _____ Early warning mechanism; <b>Sign Board</b> ✓ <input type="checkbox"/> Public Notice <input type="checkbox"/> Media Announcement <input type="checkbox"/> Guide by Traffic Police <input type="checkbox"/> Others <input type="checkbox"/> _____ Under the road rehabilitation project, sign boards will be placed at land slide prone locations

	Action plans for relevant organizations on emergencies prepared with / by; <b>RDA</b> <input checked="" type="checkbox"/> PRDA <input type="checkbox"/> Traffic Police <input type="checkbox"/> <b>Executive Engineers</b> <input checked="" type="checkbox"/> Local Authority <input type="checkbox"/> <input type="checkbox"/> DMC <input type="checkbox"/> DDMCU <input type="checkbox"/>																																																																					
	Alternative route; Exist <input type="checkbox"/> <b>Prepared temporary road construction procedure</b> <input checked="" type="checkbox"/> Not prepared <input type="checkbox"/>																																																																					
	Restoration plans of road; Prepared the procedure <input checked="" type="checkbox"/> Not prepared <input type="checkbox"/> EE will carry out urgent restoration plans for any damage to the road during the operational phase of the considered road section																																																																					
7.3 Evacuation	Evacuation systems for users; <b>No evacuation system is currently practiced by RDA for both road users and neighborhood</b> Warning <input type="checkbox"/> Evacuation route <input type="checkbox"/> Guide <input type="checkbox"/> Evacuation Center <input type="checkbox"/> Parking lot <input type="checkbox"/> Food <input type="checkbox"/> Water <input type="checkbox"/> Announcement system <input type="checkbox"/> Evacuation system for neighborhood; Warning <input type="checkbox"/> Evacuation route <input type="checkbox"/> Guide <input type="checkbox"/> Evacuation center <input type="checkbox"/> Coordination with local disaster management plan <input type="checkbox"/>																																																																					
7.4 Cooperation	Relevant organizations agreed with; <table border="1" style="width:100%; border-collapse: collapse; margin-top: 10px;"> <thead> <tr> <th></th> <th>Traffic police</th> <th>Local authority</th> <th>NBRO</th> <th>UDA</th> <th>DMC</th> <th></th> <th></th> </tr> </thead> <tbody> <tr> <td>Possible disasters</td> <td style="text-align: center;">√</td> <td style="text-align: center;">√</td> <td style="text-align: center;">√</td> <td></td> <td style="text-align: center;">√</td> <td></td> <td></td> </tr> <tr> <td>Traffic control plan</td> <td style="text-align: center;">√</td> <td></td> <td></td> <td></td> <td></td> <td></td> <td></td> </tr> <tr> <td>Inspection plan</td> <td style="text-align: center;">√</td> <td style="text-align: center;">√</td> <td style="text-align: center;">√</td> <td></td> <td style="text-align: center;">√</td> <td></td> <td></td> </tr> <tr> <td>Restoration system</td> <td></td> <td></td> <td></td> <td></td> <td style="text-align: center;">√</td> <td></td> <td></td> </tr> <tr> <td>Cooperation of disaster situation</td> <td style="text-align: center;">√</td> <td style="text-align: center;">√</td> <td style="text-align: center;">√</td> <td></td> <td style="text-align: center;">√</td> <td></td> <td></td> </tr> </tbody> </table> <table border="1" style="width:100%; border-collapse: collapse; margin-top: 10px;"> <thead> <tr> <th>Communities has been explained;</th> <th>Yes</th> <th>No</th> </tr> </thead> <tbody> <tr> <td>Possible disaster</td> <td style="text-align: center;">√</td> <td></td> </tr> <tr> <td>Warning system</td> <td style="text-align: center;">√</td> <td></td> </tr> <tr> <td>Evacuation system</td> <td></td> <td style="text-align: center;">√</td> </tr> <tr> <td>Disaster management plan with LA</td> <td style="text-align: center;">√</td> <td></td> </tr> </tbody> </table>								Traffic police	Local authority	NBRO	UDA	DMC			Possible disasters	√	√	√		√			Traffic control plan	√							Inspection plan	√	√	√		√			Restoration system					√			Cooperation of disaster situation	√	√	√		√			Communities has been explained;	Yes	No	Possible disaster	√		Warning system	√		Evacuation system		√	Disaster management plan with LA	√	
	Traffic police	Local authority	NBRO	UDA	DMC																																																																	
Possible disasters	√	√	√		√																																																																	
Traffic control plan	√																																																																					
Inspection plan	√	√	√		√																																																																	
Restoration system					√																																																																	
Cooperation of disaster situation	√	√	√		√																																																																	
Communities has been explained;	Yes	No																																																																				
Possible disaster	√																																																																					
Warning system	√																																																																					
Evacuation system		√																																																																				
Disaster management plan with LA	√																																																																					

**8. Confirmation of Monitoring Arrangements during the Construction Stage:**

8.1	Had Construction method statement been prepared?	Yes√	No
8.2	Is the construction method statement including the disaster management plan?	Yes√	No
8.3	Is it prepared any response system against any problem?	Yes√	No
8.4	Had the project plan been explained to the neighborhood residents/ communities?	Yes√	No
8.2	Have the contact person been announced to the residents / community?	Yes√	No

These activities/measures are addressed through the Environmental Management Plan which has been included to the construction method statement.

**Details of the Responsible Officer for Form B: (for RDA, Nominated Officer from ESD)**

Name of Officer		H.M.N.M. Wijayasinghe	
Designation		Hydrologist	
Division & Organization		Environmental and Social Development Division, Road Development Authority	
Contact Details	Telephone	Office	0112862443
		Mobile	0714446103
		Fax	0112862443
	Email Address	<a href="mailto:malakanavin@gmail.com">malakanavin@gmail.com</a>	

Signature of Responsible Officer: \_\_\_\_\_

Name of Responsible Officer: \_\_\_\_\_

Date:

Location Map

75+500 – 86+500km section of Avisawwella – Hatton – Nuwara Eliya

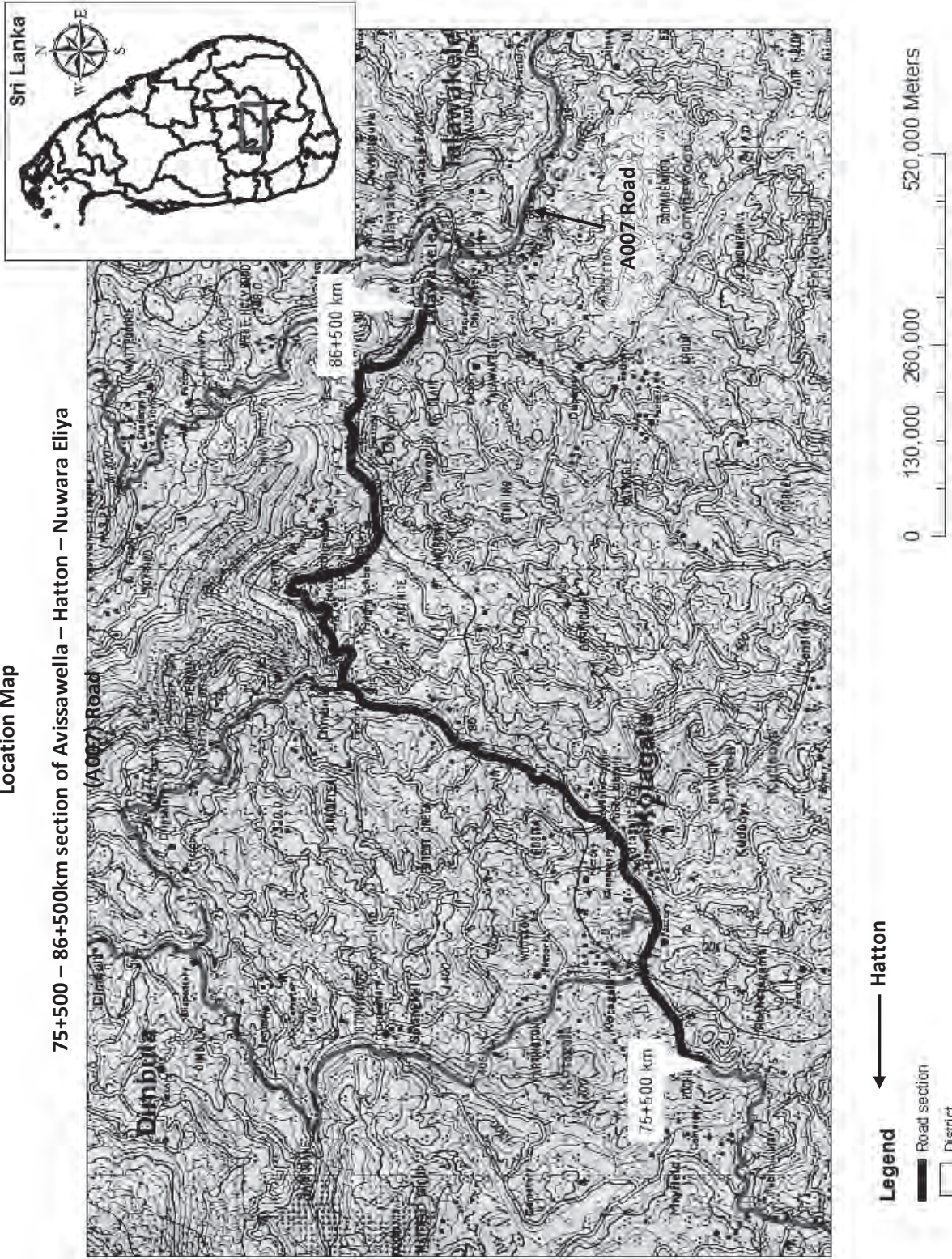

Area more than 30 degree slope

75+500 – 86+500km section of Avissawella – Hatton – Nuwara Eliya  
(A007) Road

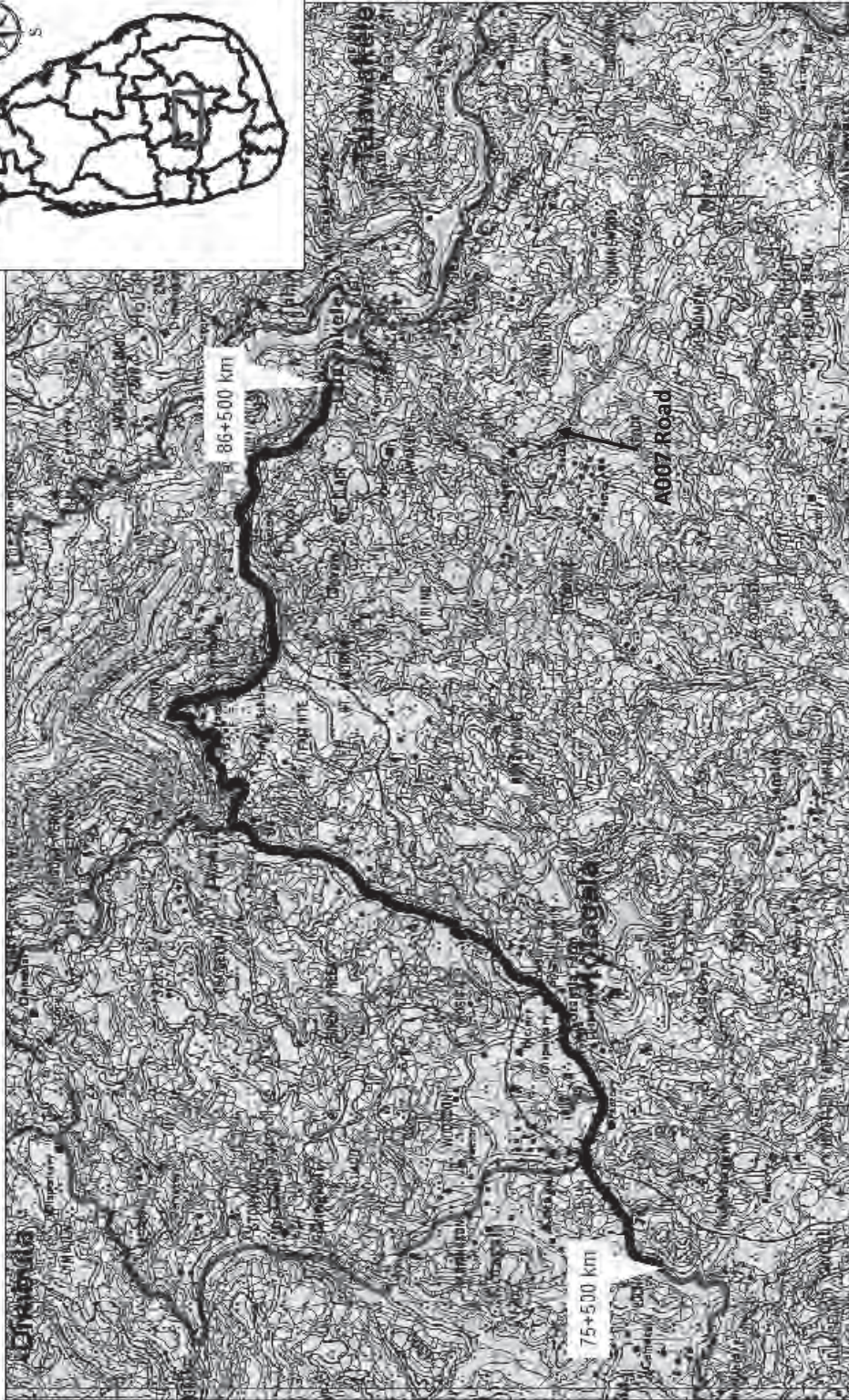

**Legend** ← Hatton

- Road section
- Slope > 30 deg
- District

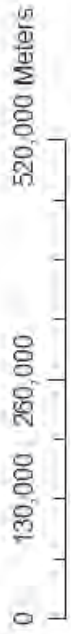

Landslide Hazardous Zones

75+500 – 86+500km section of Avissawella – Hatton – Nuwara Eliya

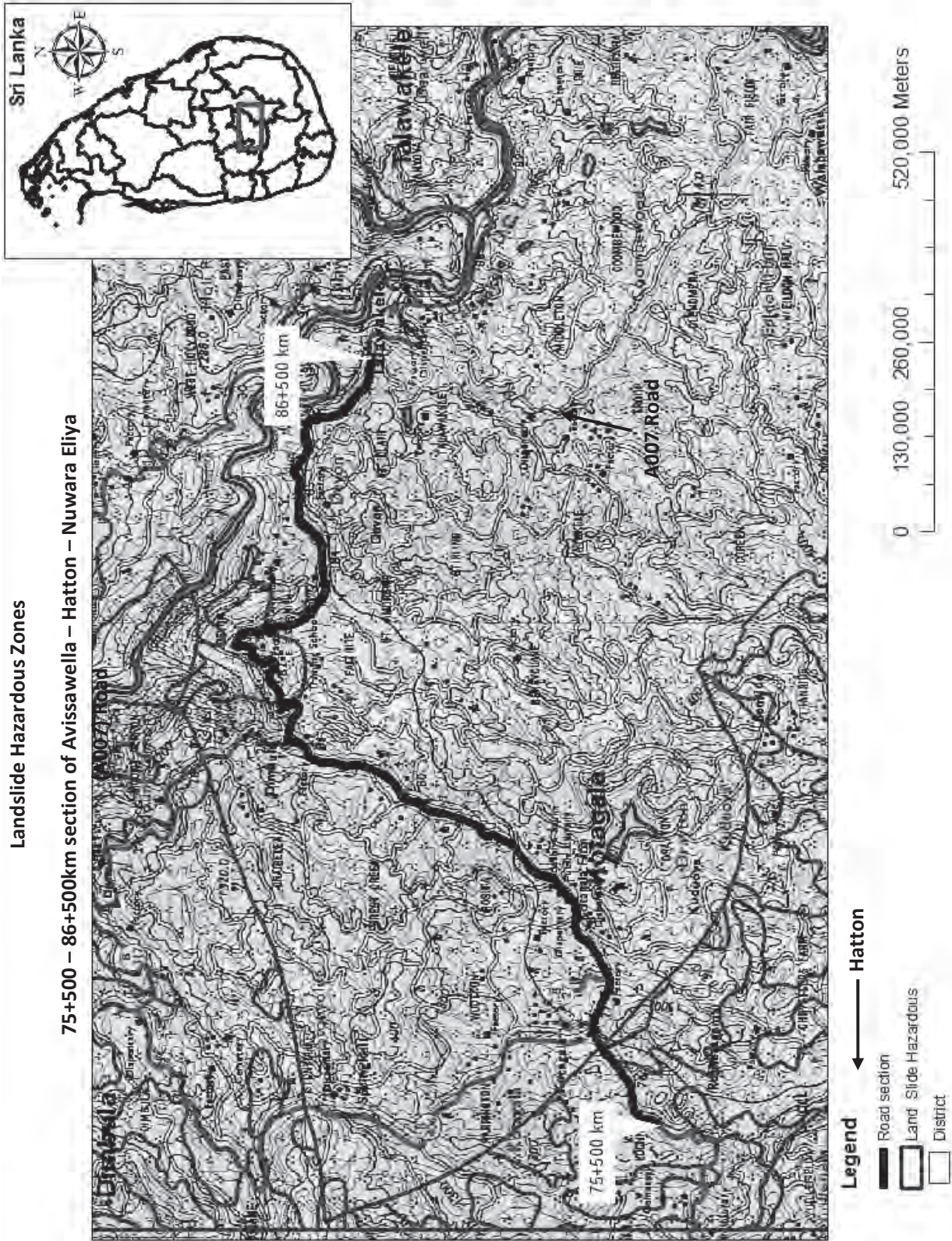



Drainage Network

75+500 – 86+500km section of Avisawella – Hatton – Nuwara Eliya  
(A007) Road

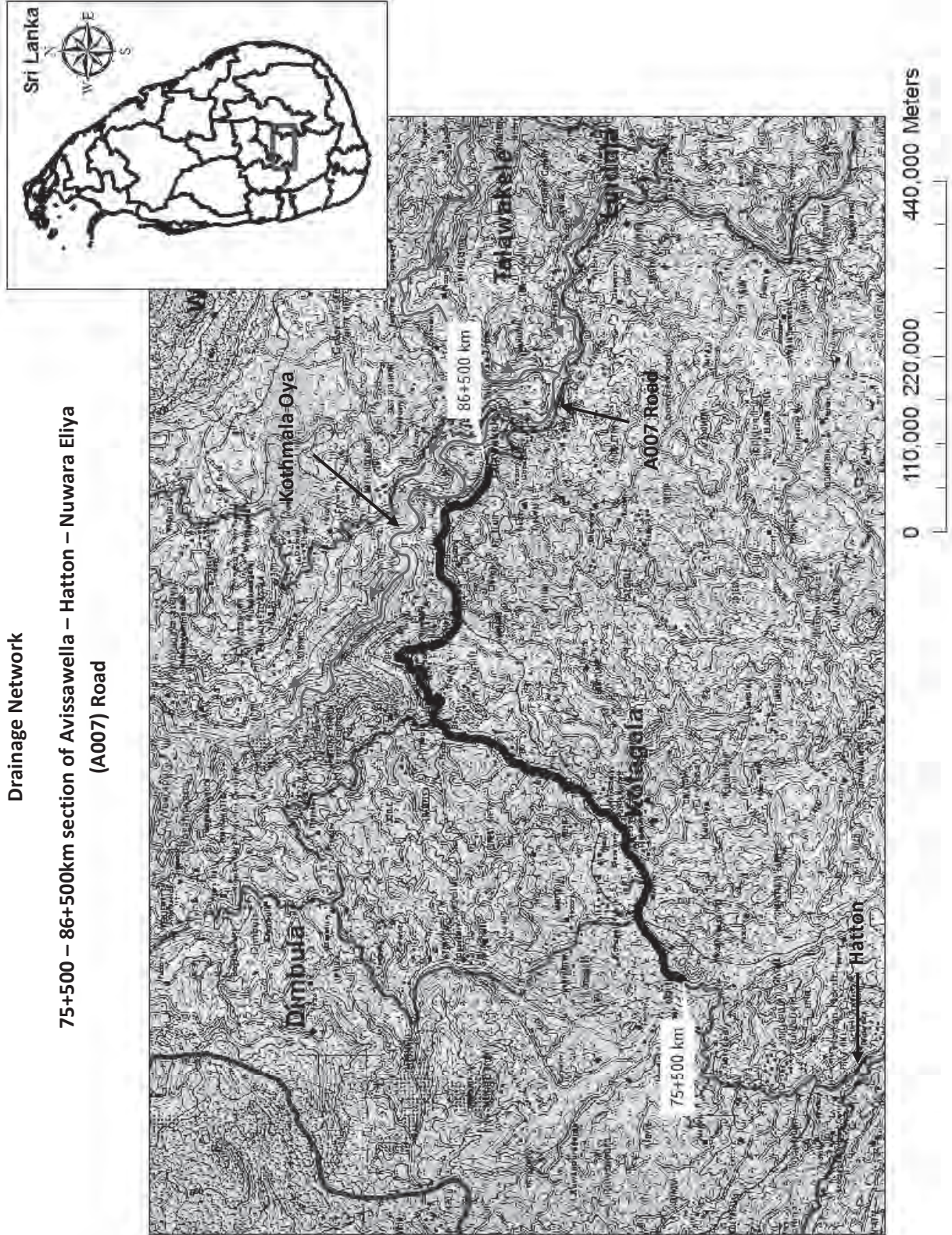

**Structural Details From 75+500 to 86+500**

Culverts		Retaining walls				Bridgs	
Chainage	No	From	To	Side	Wall Type	Chainage	No
<b>75 km</b>							
75+563	75/11	75+355	75+375	LHS			
75+578	75/12	75+815	75+845	LHS			
75+707	76/01						
75+875	76/02						
75+956	76/03						
<b>76 km</b>							
76+026	76/04	76+235	76+245	LHS			
76+127	76/05	76+575	76+595	LHS			
76+200	76/06						
76+294	76/07						
76+393	76/08						
76+567	76/09						
76+698	77/01						
76+858	77/02						
76+986	77/03						
<b>77 km</b>							
77+098	77/04						
77+176	77/05						
77+315	77/06						
77+533	77/07						
77+767	78/01						
<b>78 km</b>							
78+129	78/02	78+957	78+970	RHS	Toe Wall	78+980	79/2
Kotagala town area							
<b>79 km</b>							
79+156	79/03	79+010	79+030	LHS	Protection Wall		
79+270	79/04	79+175	79+215	RHS			
79+307	79/05	79+855	79+875	LHS			
79+359	79/06						
79+483	79/07						
79+545	79/08						
79+653	80/01						
79+697	80/02						
79+751	80/03						
79+792	80/04						
79+846	80/05						
79+891	80/06						
79+918	80/07						
79+973	80/08						
79+992	80/09						

80 km							
80+019	80/10	80+645	80+685	RHS	Retaining Wall		
80+086	80/11						
80+163	80/12						
80+233	80/13						
80+308	80/14						
80+341	80/15						
80+382	80/16						
80+454	80/17						
80+527	80/18						
80+626	81/01						
80+697	81/02						
80+806	81/03						
80+867	81/04						
80+934	81/05						
80+985	81/06						
81 km							
81+057	81/07	81+515	81+535	RHS	Protection Wall		
81+120	81/08	81+715	81+740	RHS	Protection Wall		
81+192	81/09						
81+336	81/10						
81+397	81/11						
81+423	81/12						
81+497	81/13						
81+557	81/14						
81+633	82/1						
81+670	82/2						
81+706	82/3						
81+765	82/4						
81+842	82/5						
81+972	82/6						
82 km							
82+044	82/7	82+395	82+445	RHS	Protection Wall		
82+132	82/8	82+468	82+485	RHS	Protection Wall		
82+232	82/9	82+550	82+610	RHS	Protection Wall		
82+258	82/10						
82+335	82/11						
82+548	82/12						
82+627	83/01						
82+886	83/02						
82+944	83/03						
83 km							
83+195	83/04	83+330	83+440	RHS	Protection Wall		
83+350	83/05						
83+447	83/06						
83+573	84/01						
83+680	84/02						
83+800	84/03						
83+973	84/04						

84 km							
84+097	84/05	84+300	84+470	LHS	Retaining Wall	84+248	84/7
84+164	84/06	84+535	84+630	LHS	Retaining Wall		
	84/08	84+650	84+705	LHS	Retaining Wall		
84+464	84/09	84+390 to 450 Concrete Access Road					
84+595	85/01						
84+675	85/02						
84+767	85/03						
84+877	85/04						
84+953	85/05						
85 km							
85+142	85/06	85+103	85+145	RHS	Protection Wall		
85+191	85/07	85+165	85+195	RHS	Gabion wall		
85+285	85/08	85+195	85+210	RHS	Protection Wall		
85+341	85/09	85+300	85+325	RHS	Protection Wall		
85+410	85/10	85+655	85+705	LHS	Retaining Wall		
85+470	85/11	85+800	85+825	RHS	Protection Wall		
85+584	86/01	85+940	85+975	RHS	Protection Wall		
85+700	86/02						
85+751	86/03						
85+790	86/04						
86 km							
86+036	86/05	86+105	86+155	LHS	Retaining Wall		
86+216	86/06	86+460	86+500	RHS	Gabion wall		
86+276	86/07						
86+348	86/08						
86+389	86/09						
86+479	86/10						

RW - Retaining wall

TW - Toe wall

SPW - Slope Protection wall

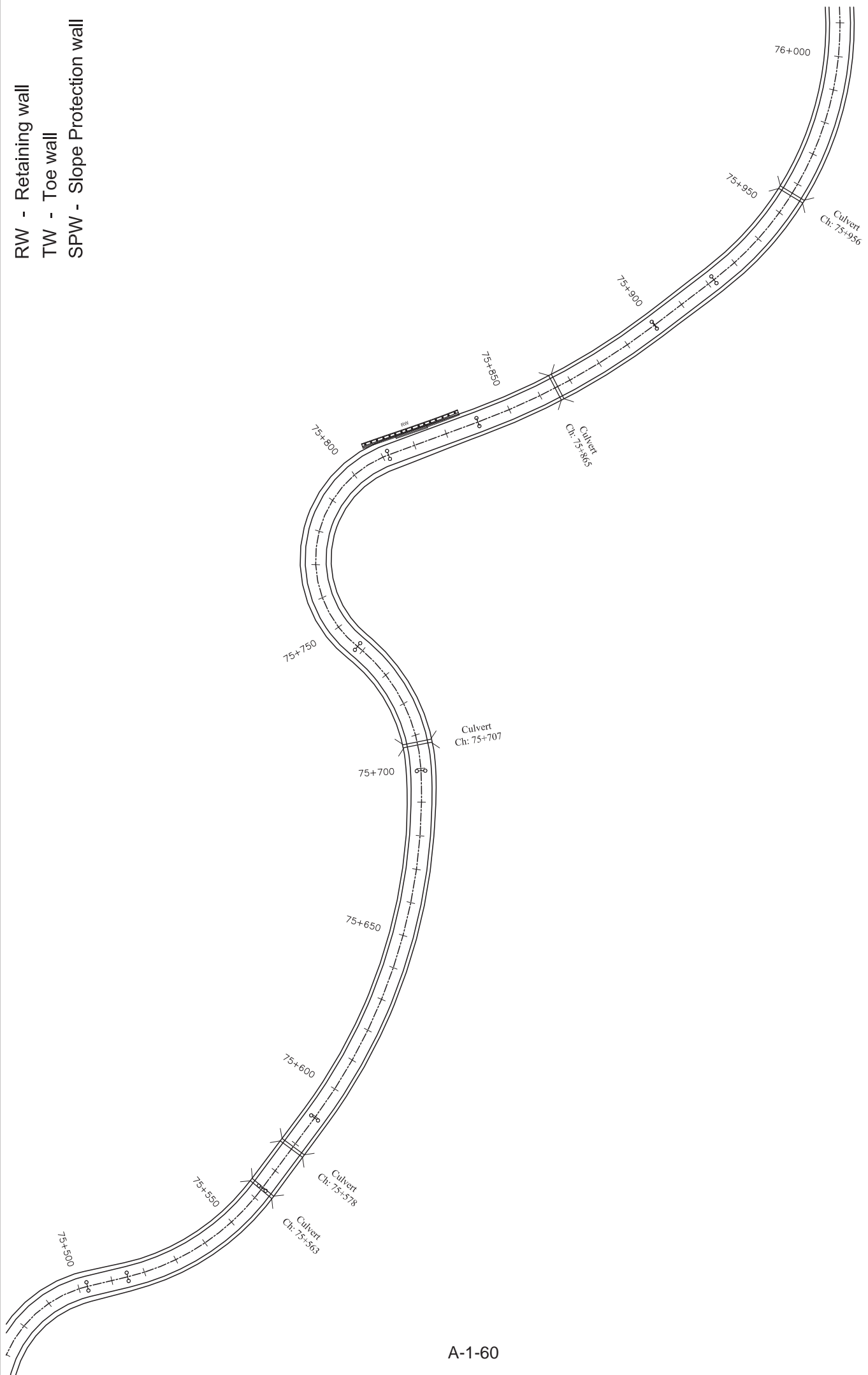

- RW - Retaining wall
- TW - Toe wall
- SPW - Slope Protection wall

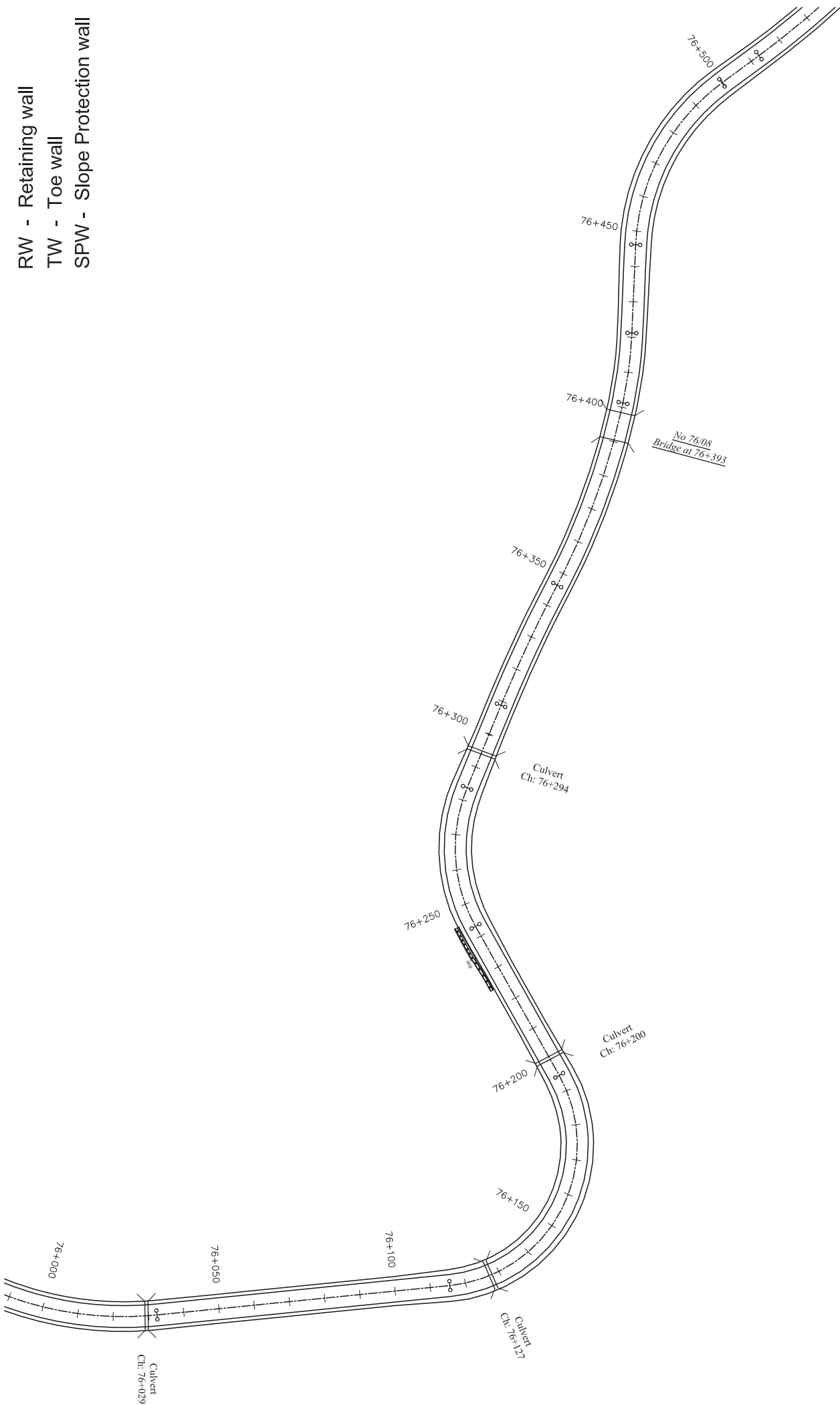

- RW - Retaining wall
- TW - Toe wall
- SPW - Slope Protection wall

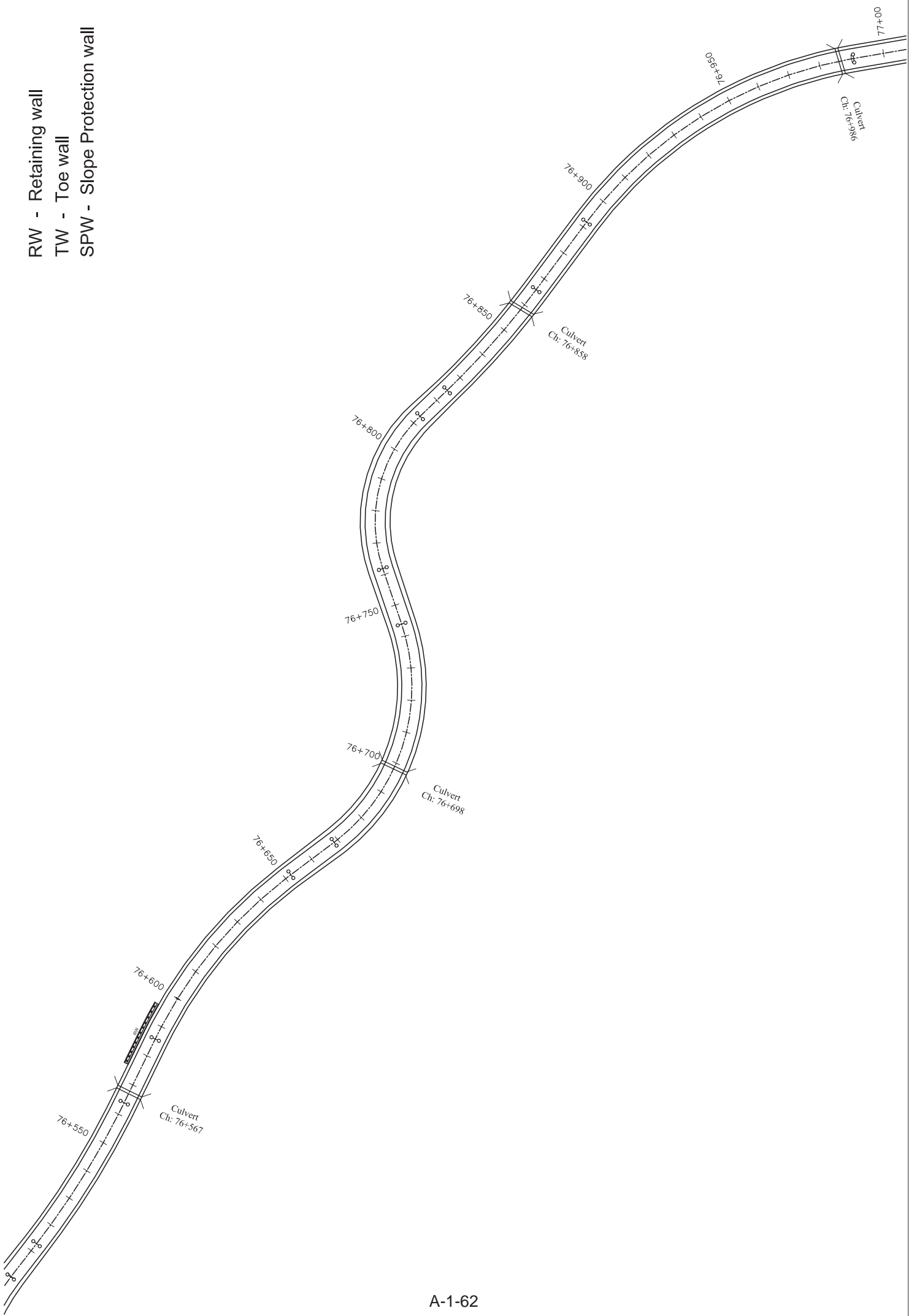

RW - Retaining wall  
TW - Toe wall  
SPW - Slope Protection wall

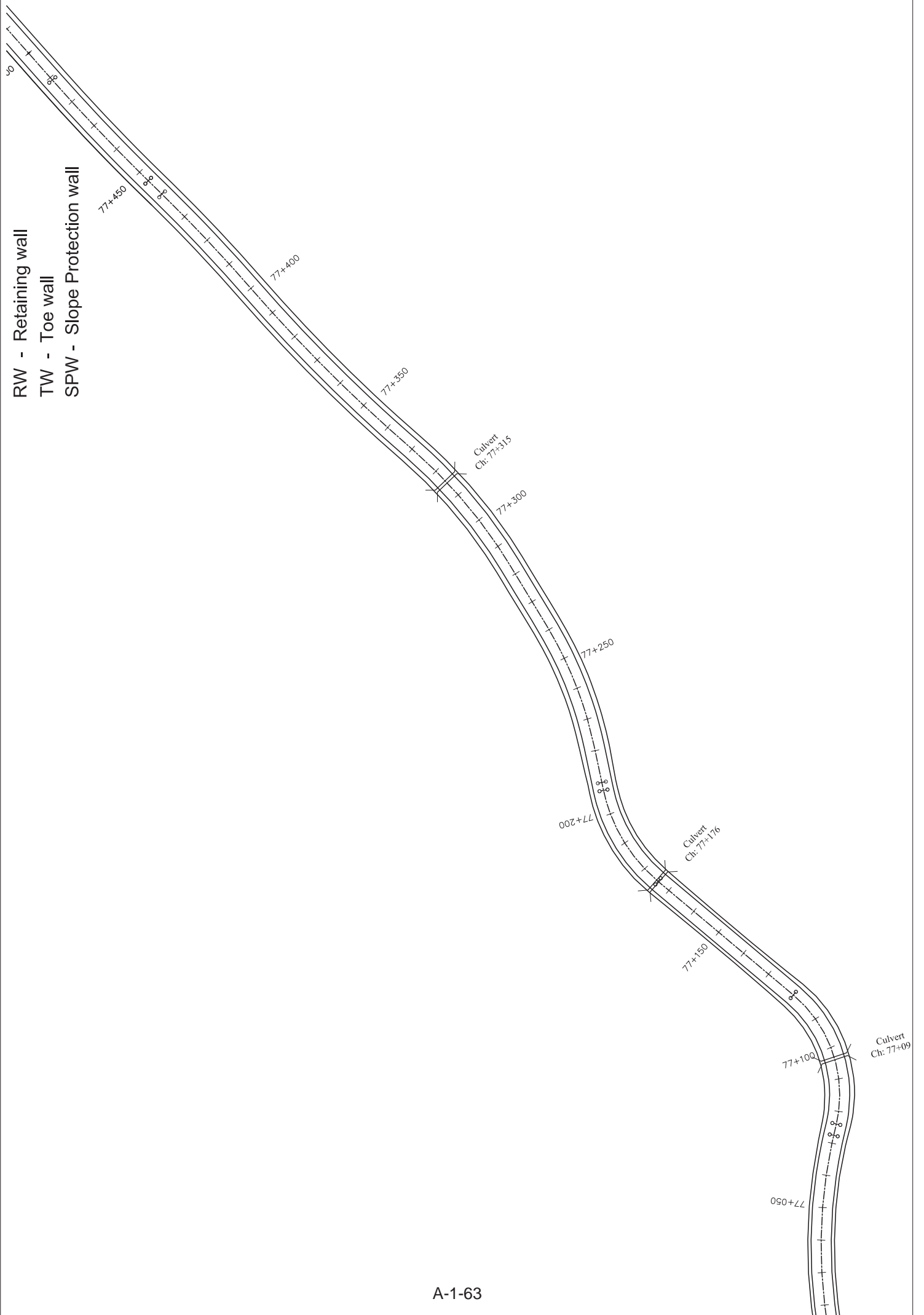



RW - Retaining wall  
TW - Toe wall  
SPW - Slope Protection wall

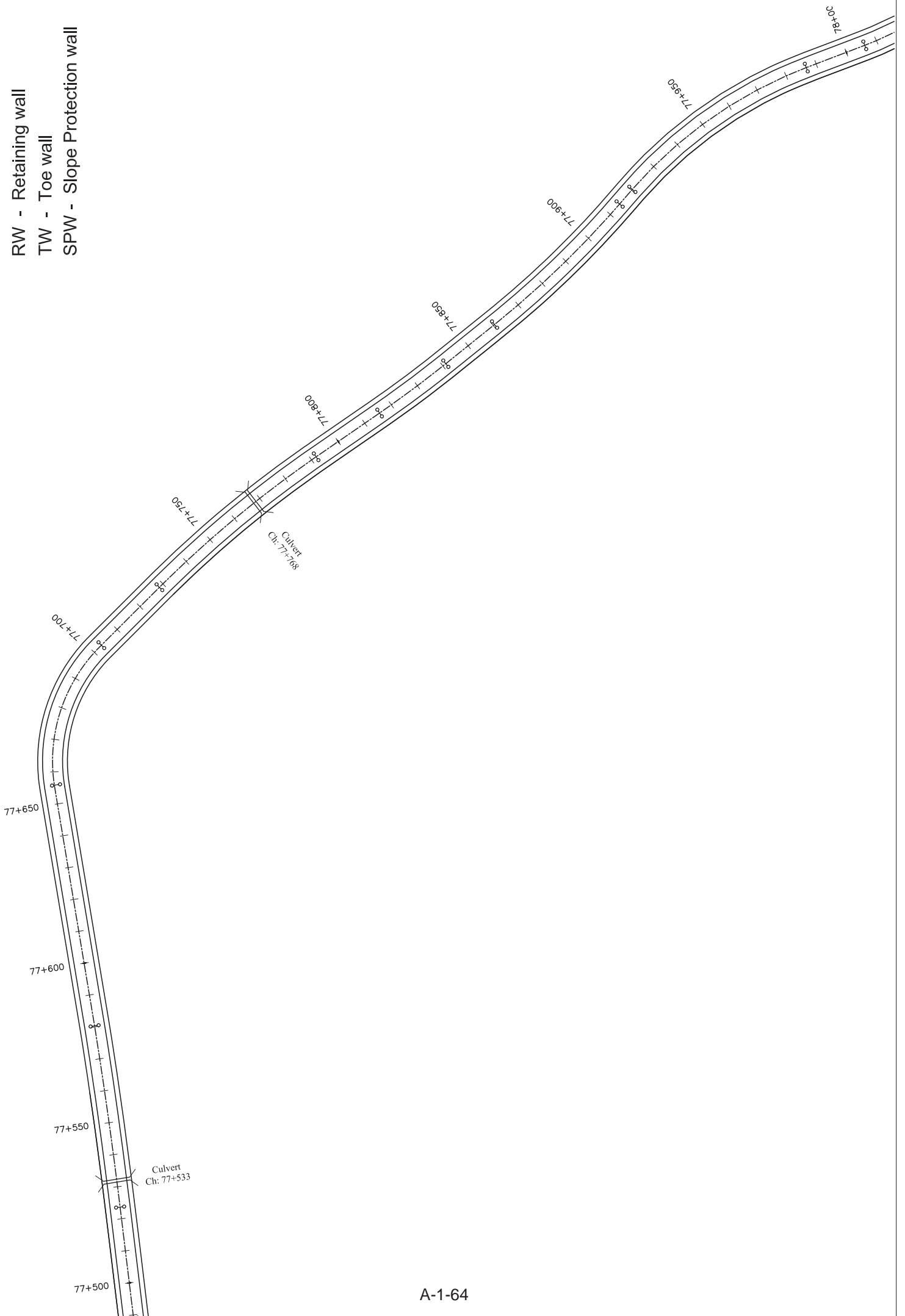

RW - Retaining wall  
TW - Toe wall  
SPW - Slope Protection wall

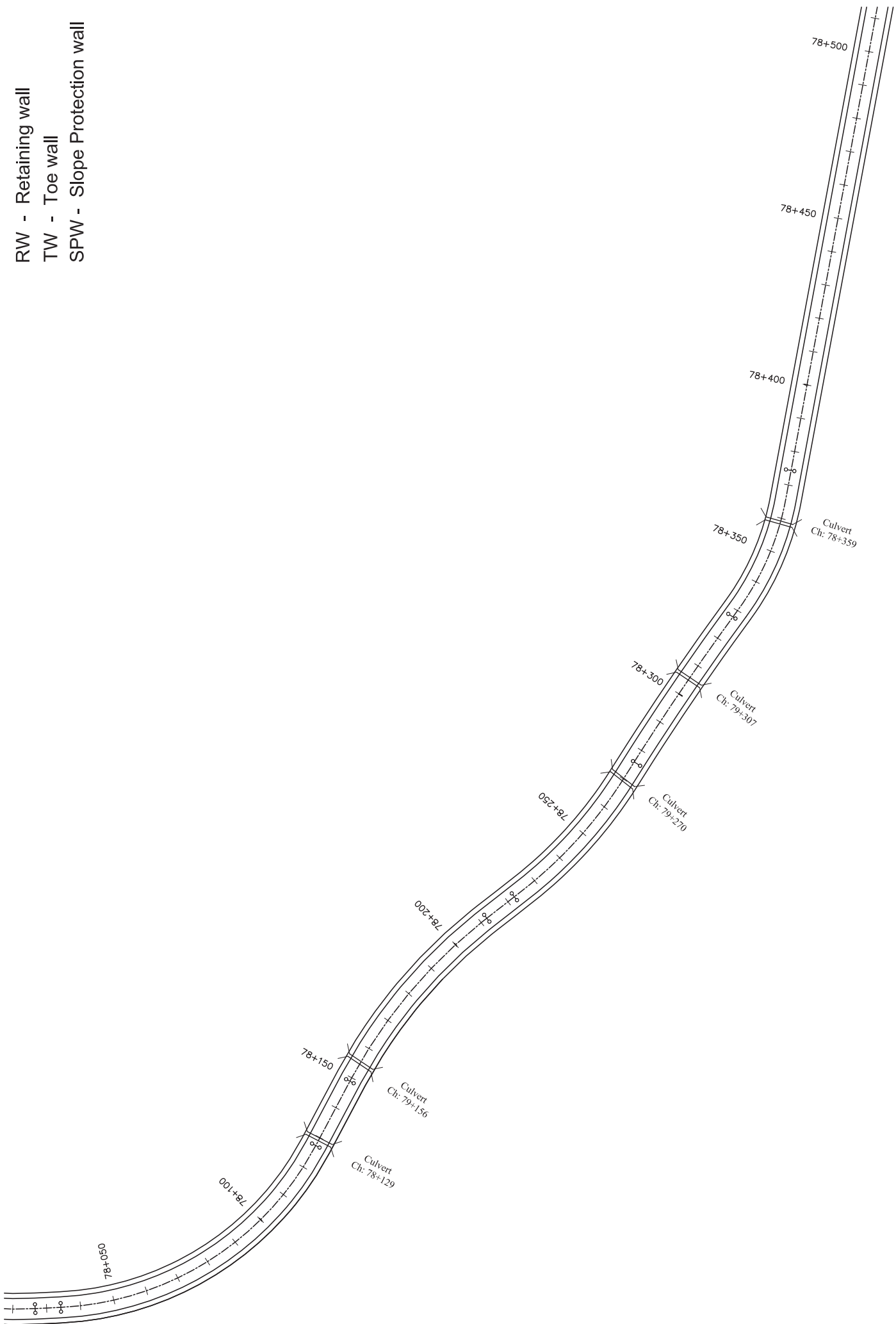

- RW - Retaining wall
- TW - Toe wall
- SPW - Slope Protection wall

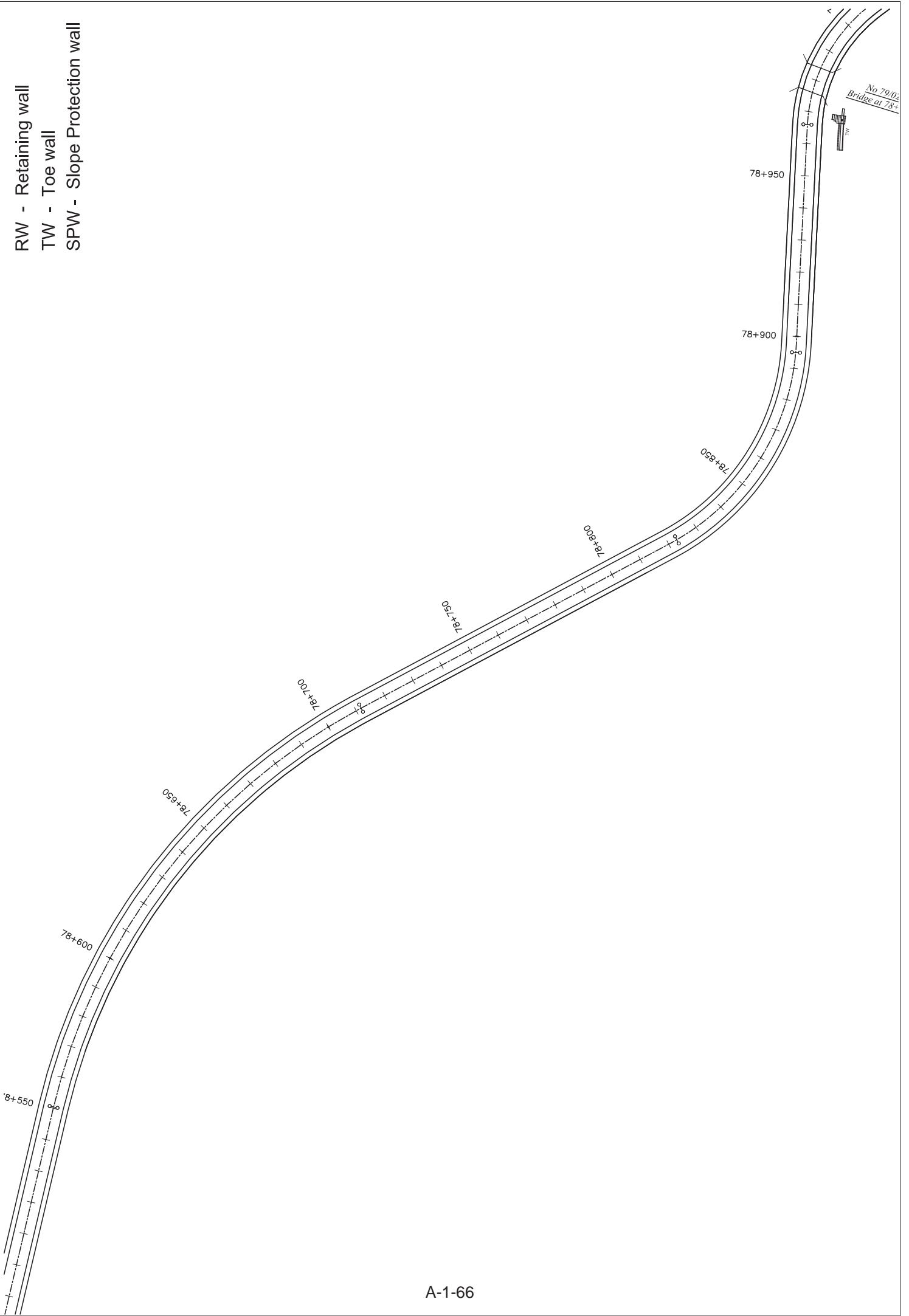

- RW - Retaining wall
- TW - Toe wall
- SPW - Slope Protection wall

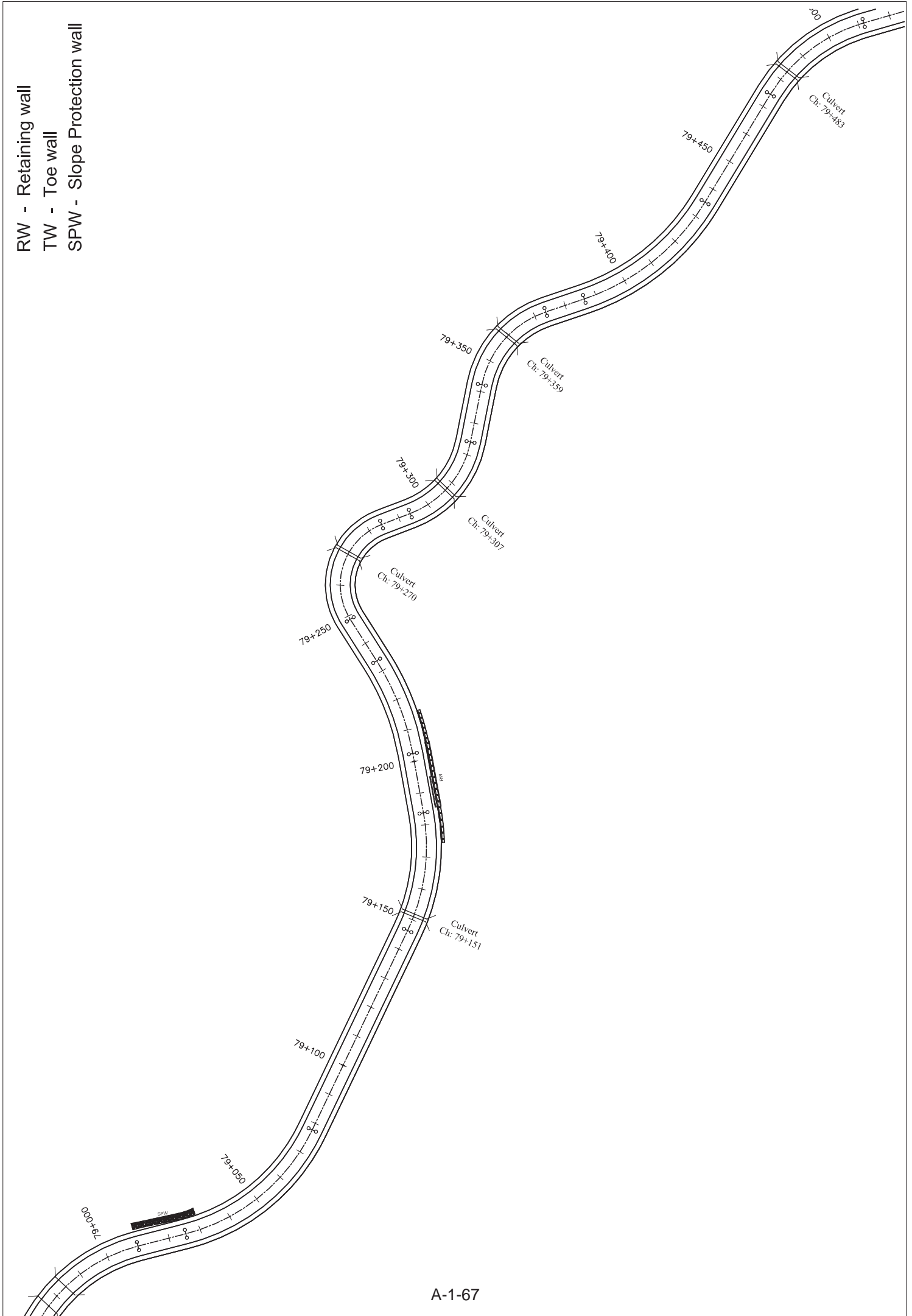

RW - Retaining wall  
TW - Toe wall  
SPW - Slope Protection wall

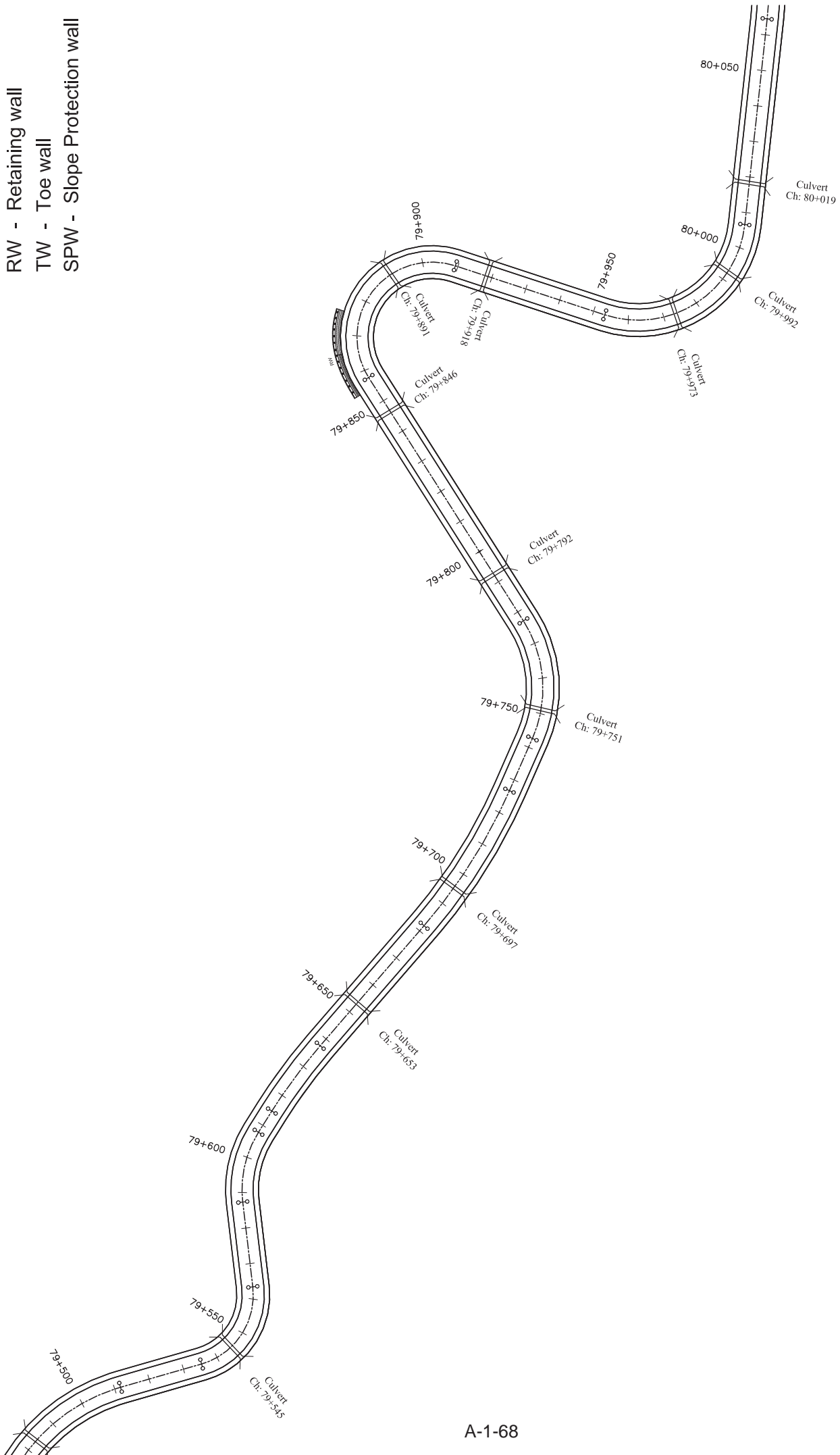

RW - Retaining wall  
TW - Toe wall  
SPW - Slope Protection wall

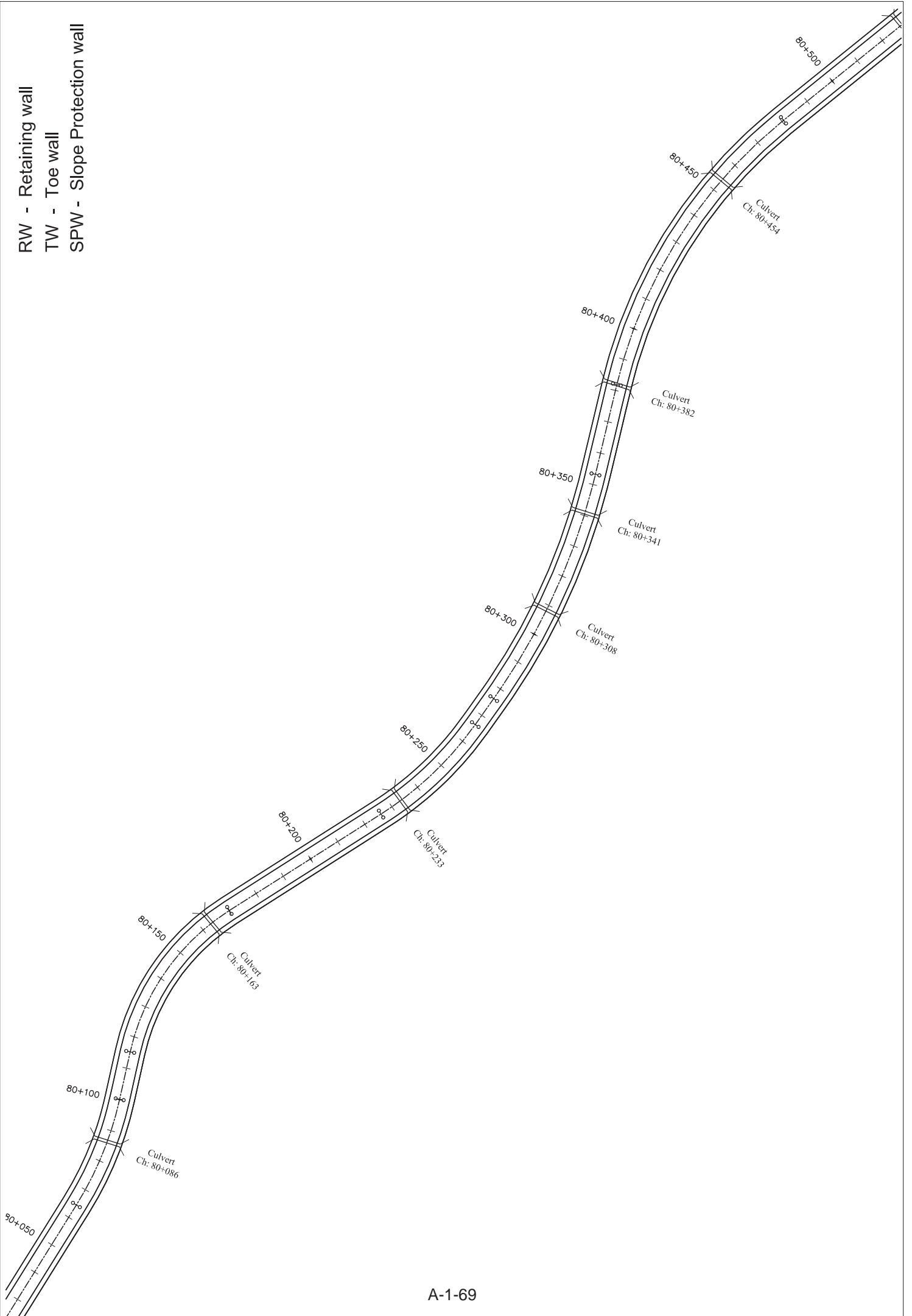

RW - Retaining wall  
TW - Toe wall  
SPW - Slope Protection wall

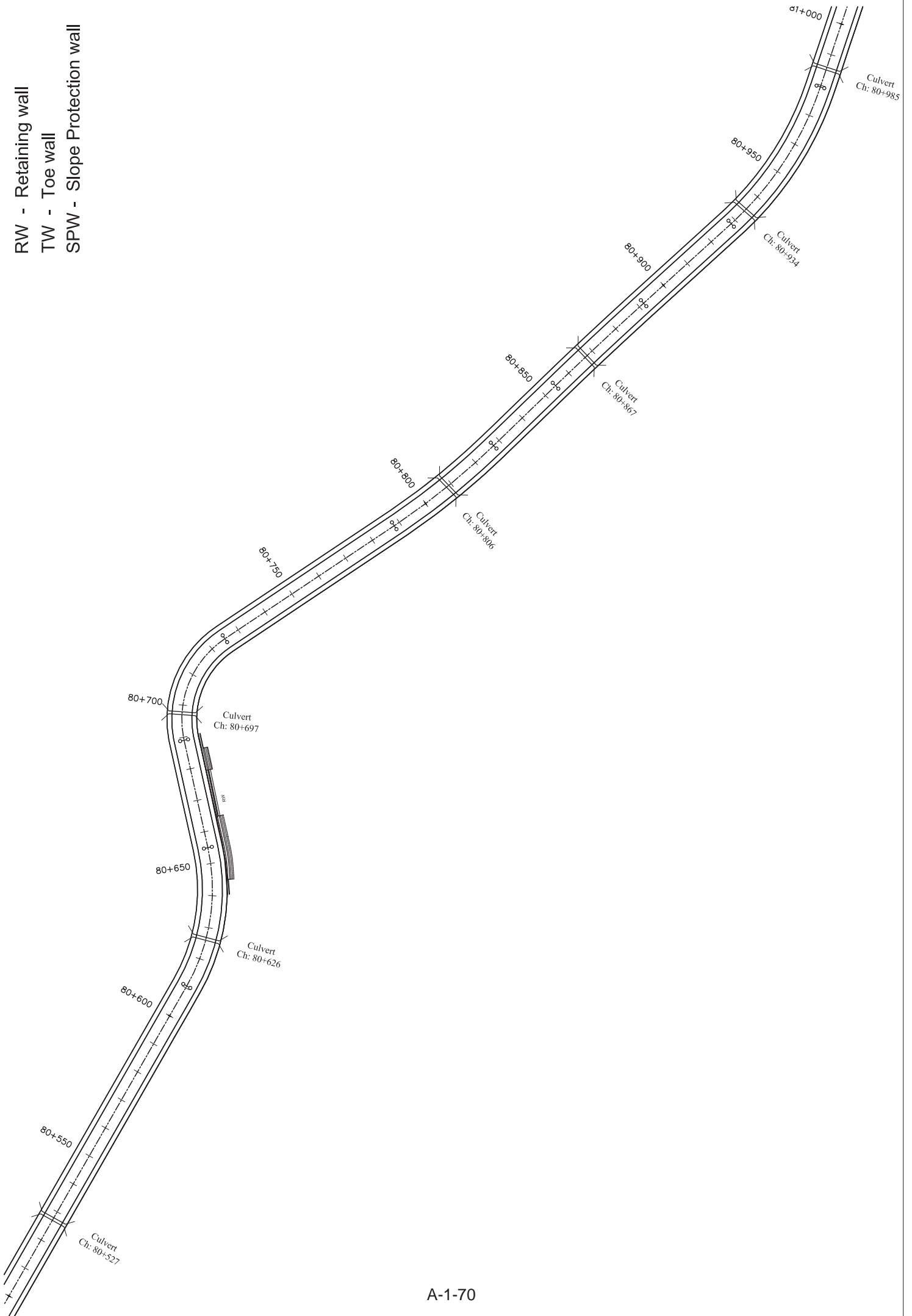

RW - Retaining wall  
TW - Toe wall  
SPW - Slope Protection wall

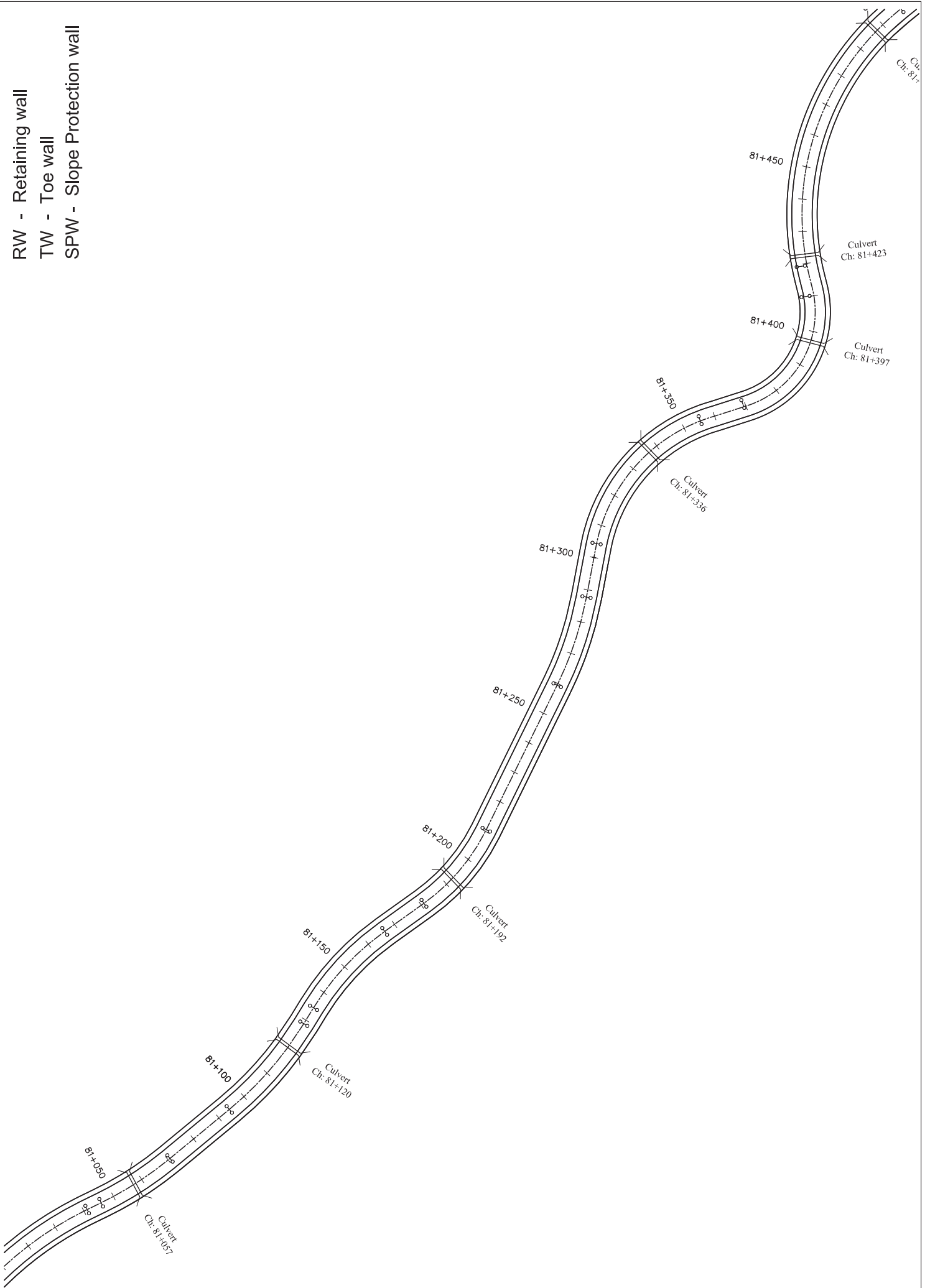



RW - Retaining wall  
TW - Toe wall  
SPW - Slope Protection wall

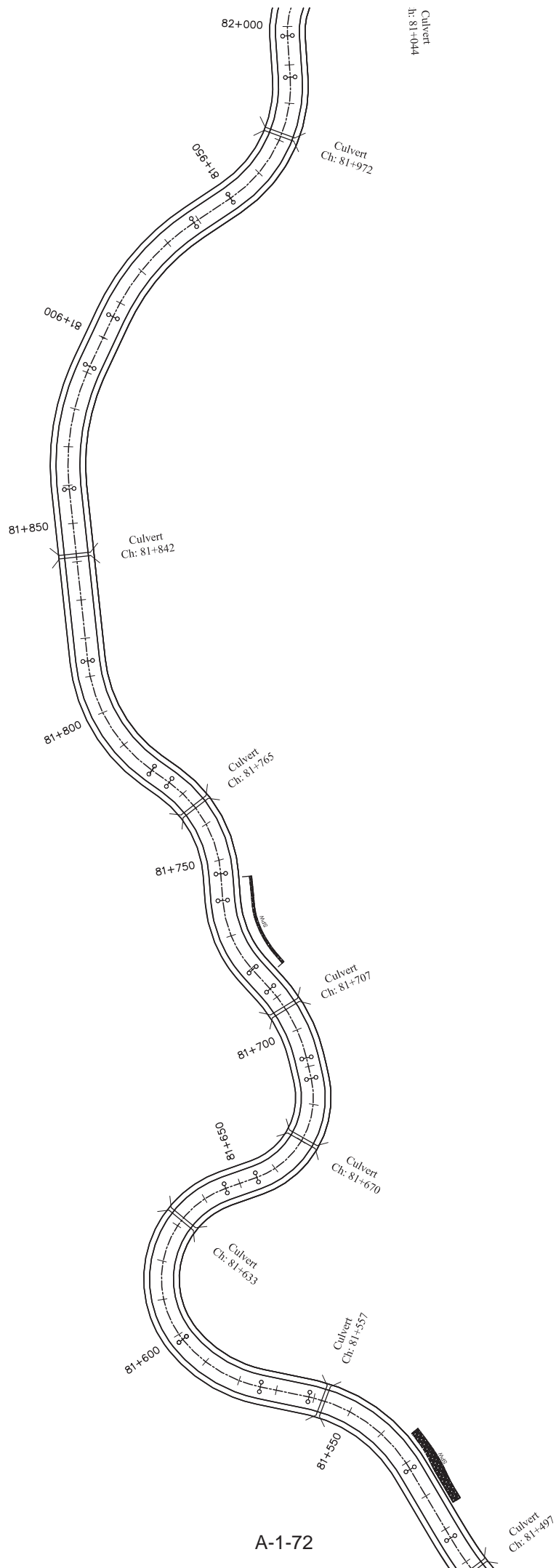

A-1-72

RW - Retaining wall  
 TW - Toe wall  
 SPW - Slope Protection wall

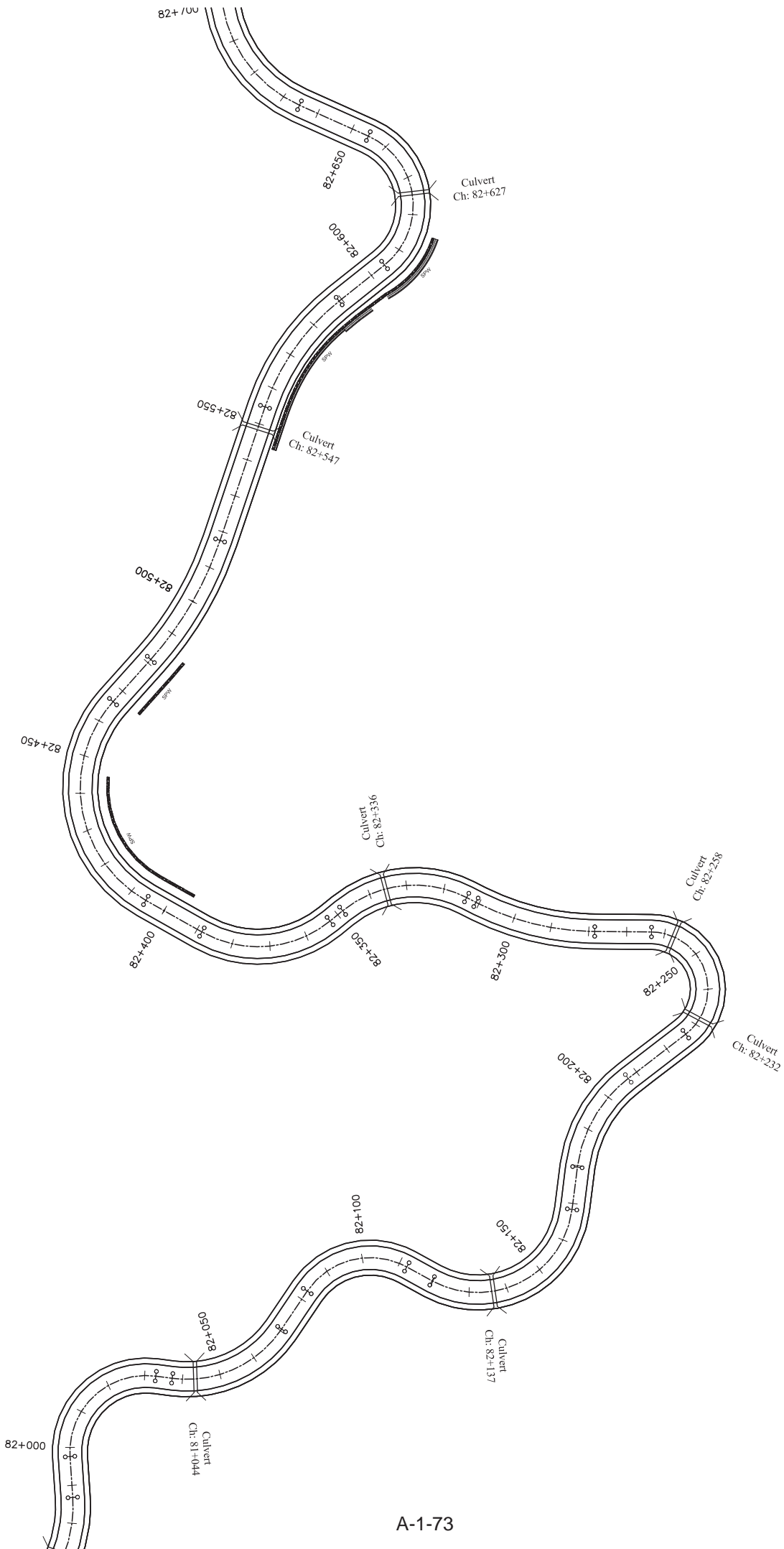

RW - Retaining wall  
TW - Toe wall  
SPW - Slope Protection wall

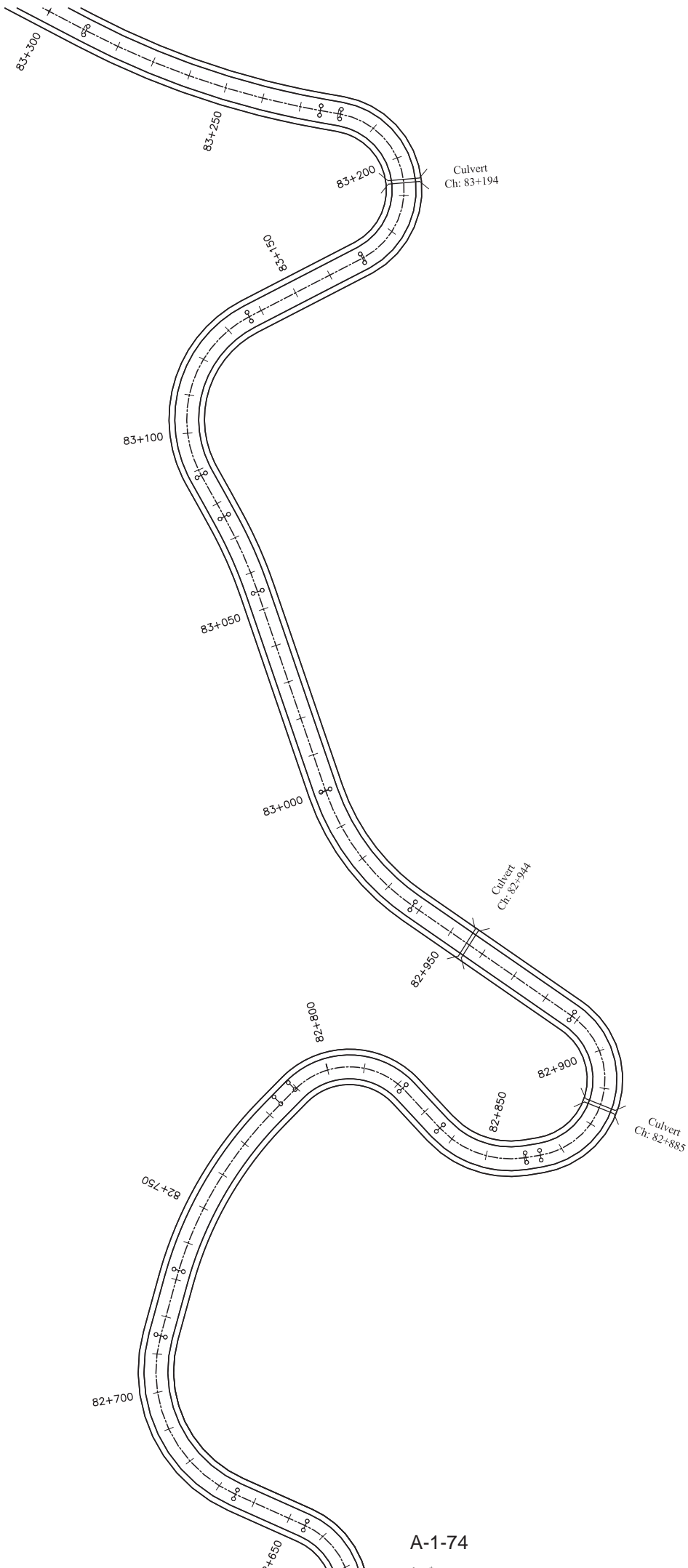

A-1-74

RW - Retaining wall

TW - Toe wall

SPW - Slope Protection wall

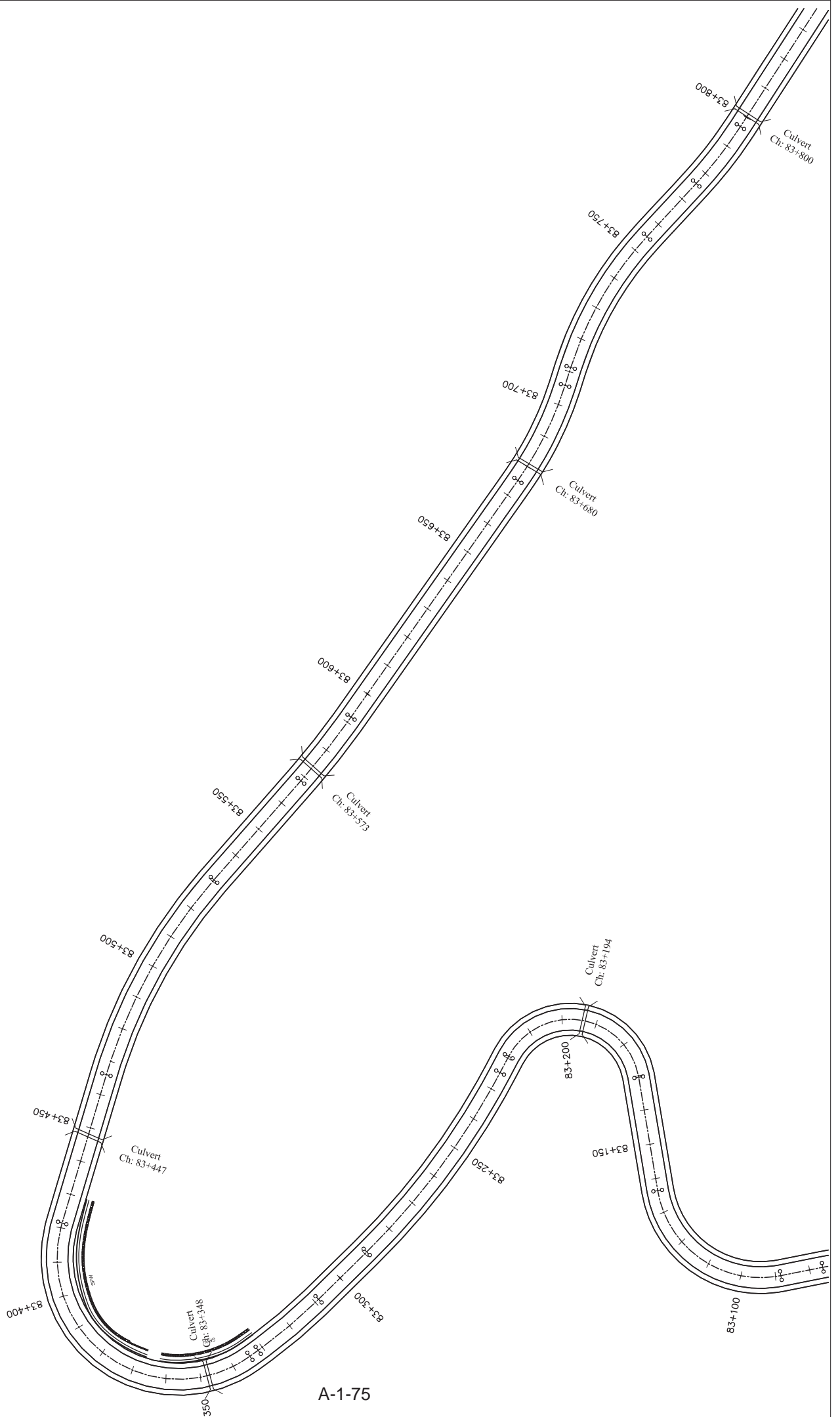

A-1-75

- RW - Retaining wall
- TW - Toe wall
- SPW - Slope Protection wall

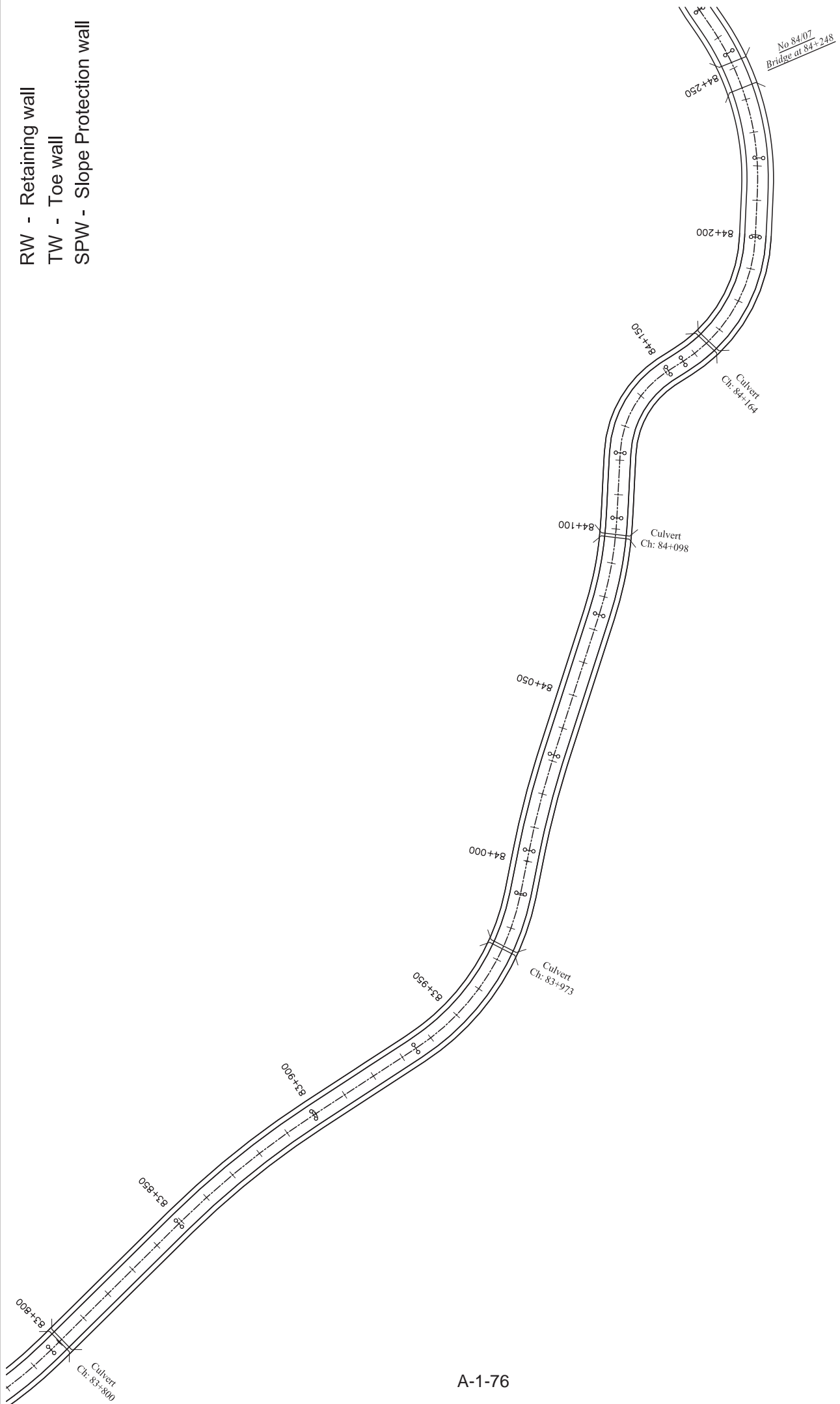

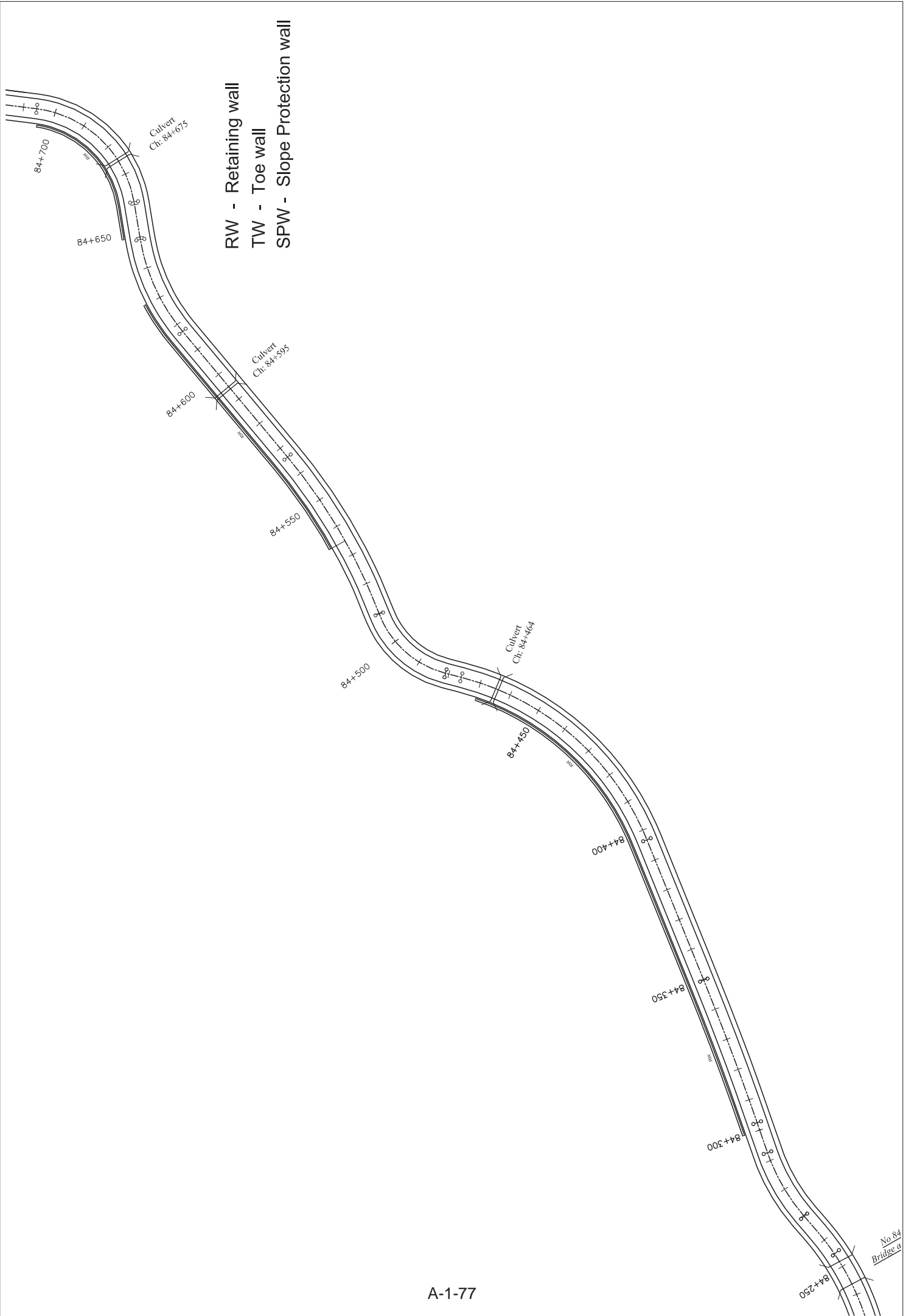

RW - Retaining wall  
TW - Toe wall  
SPW - Slope Protection wall

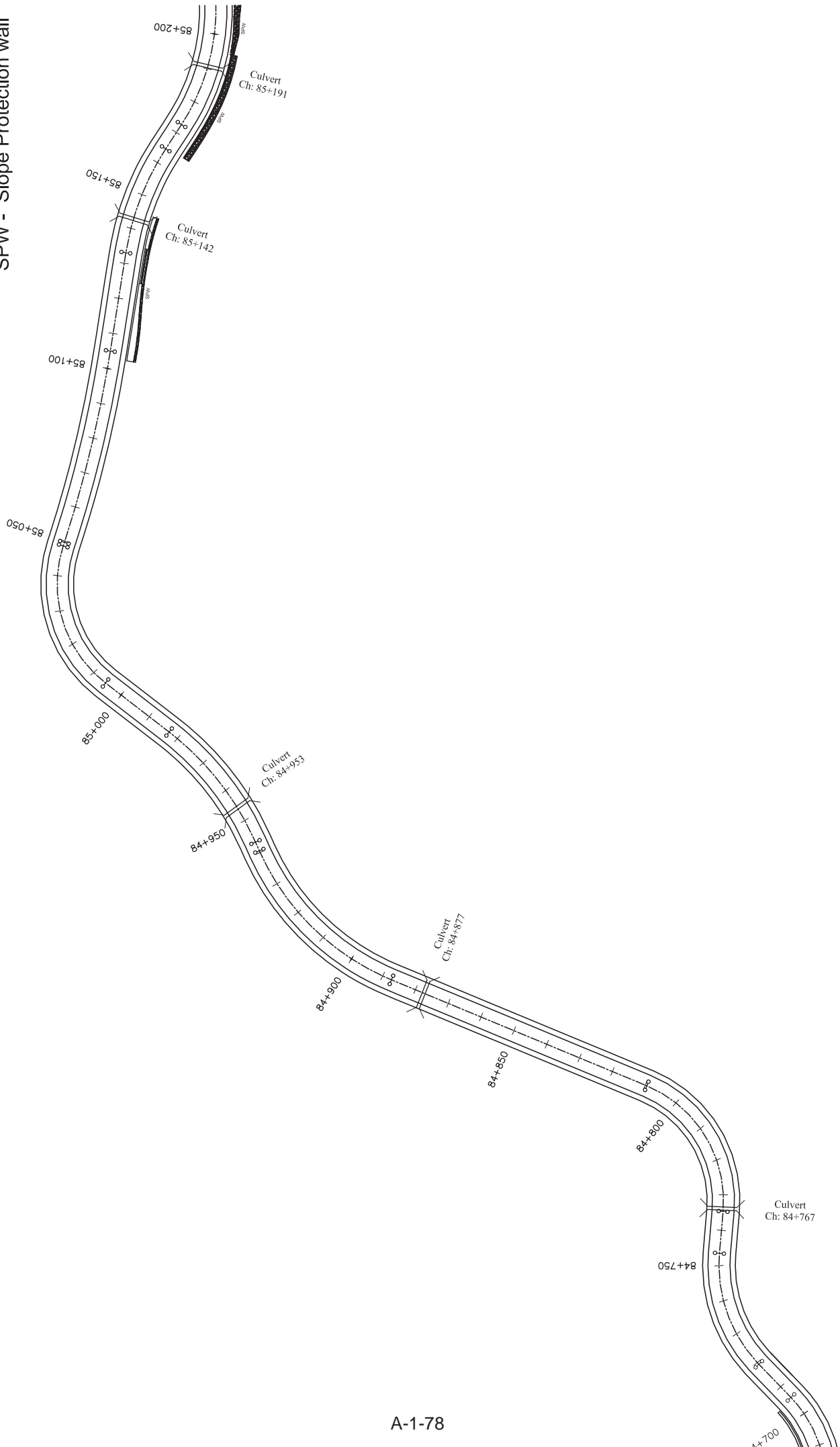

RW - Retaining wall

TW - Toe wall

SPW - Slope Protection wall

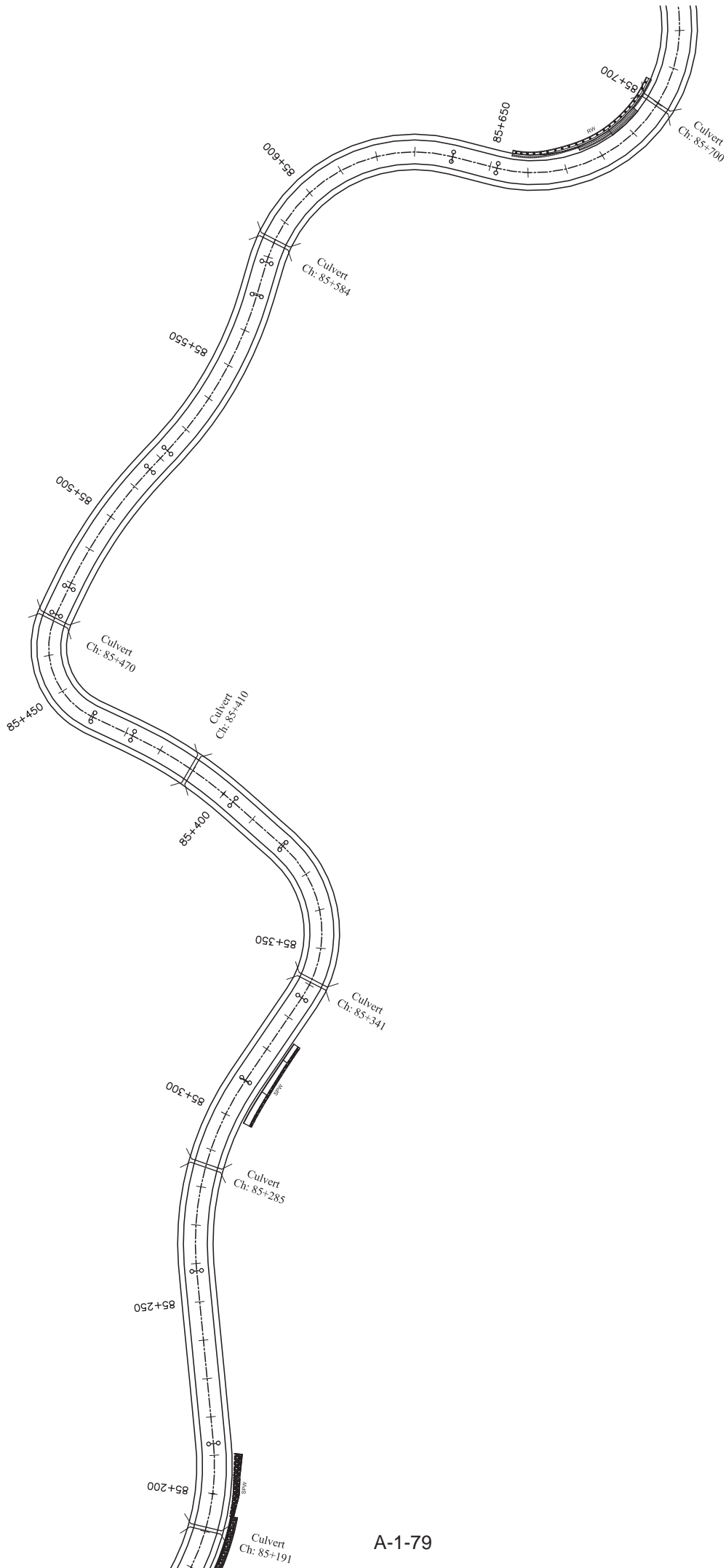



RW - Retaining wall

TW - Toe wall

SPW - Slope Protection wall

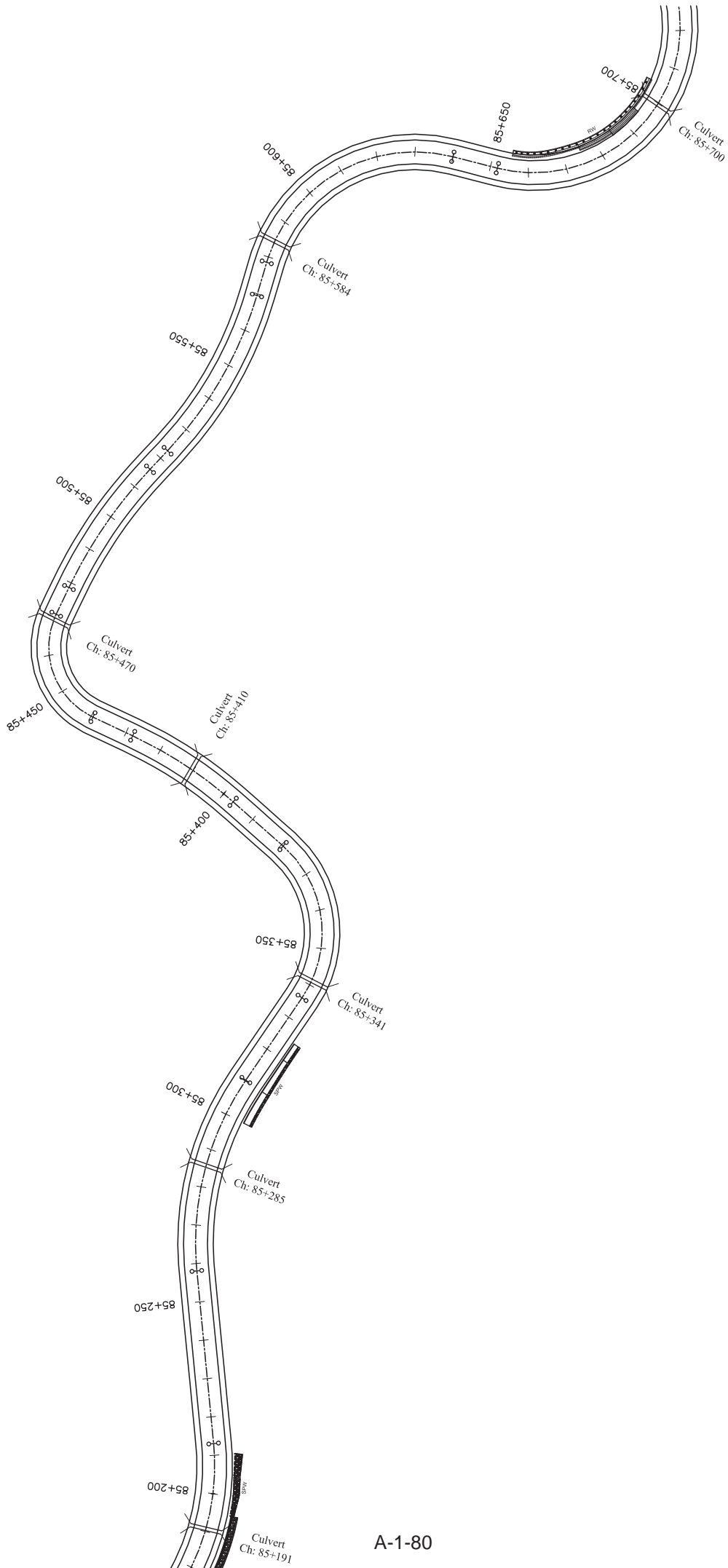

RW - Retaining wall

TW - Toe wall

SPW - Slope Protection wall

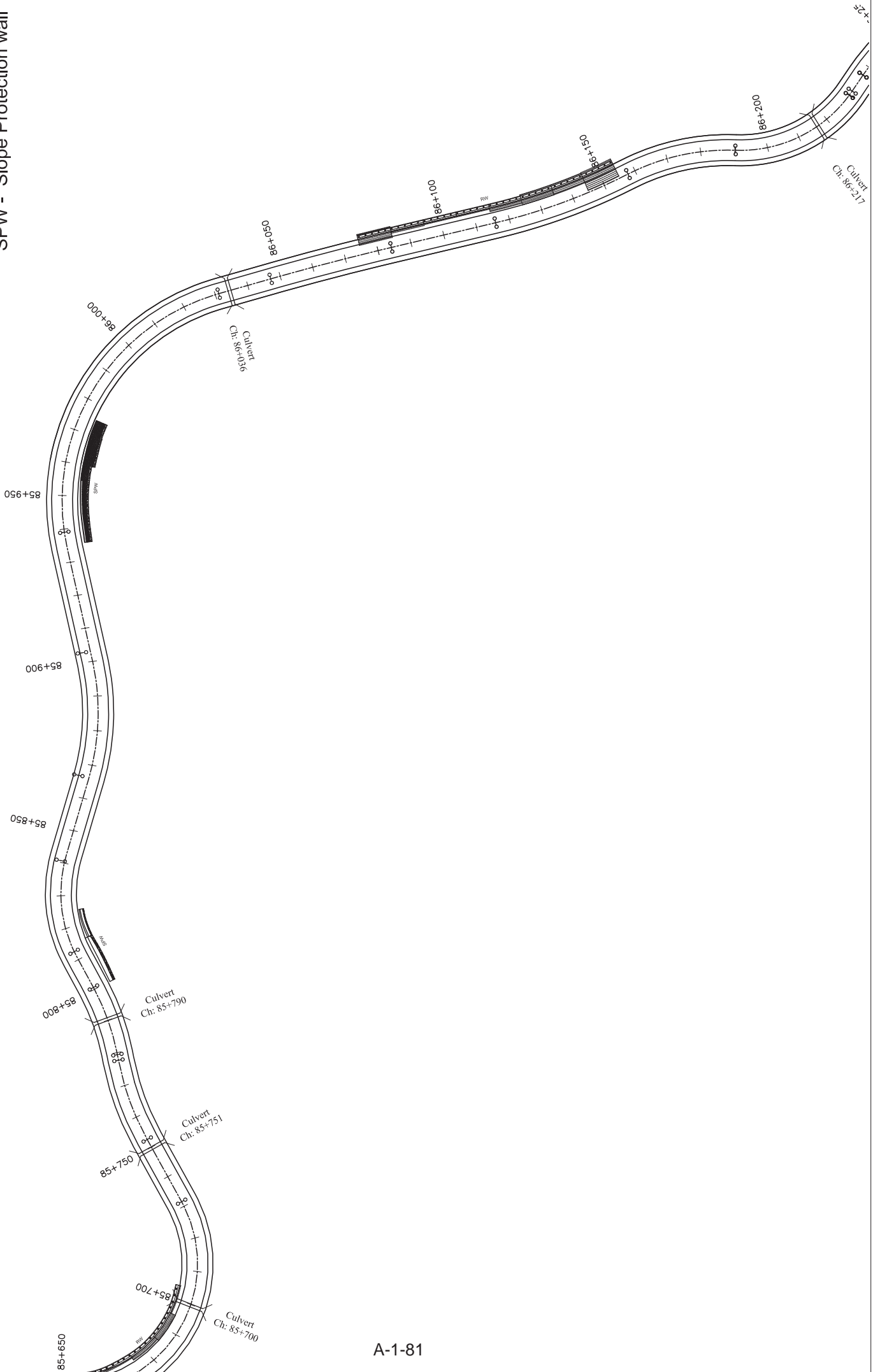

RW - Retaining wall  
 TW - Toe wall  
 SPW - Slope Protection wall

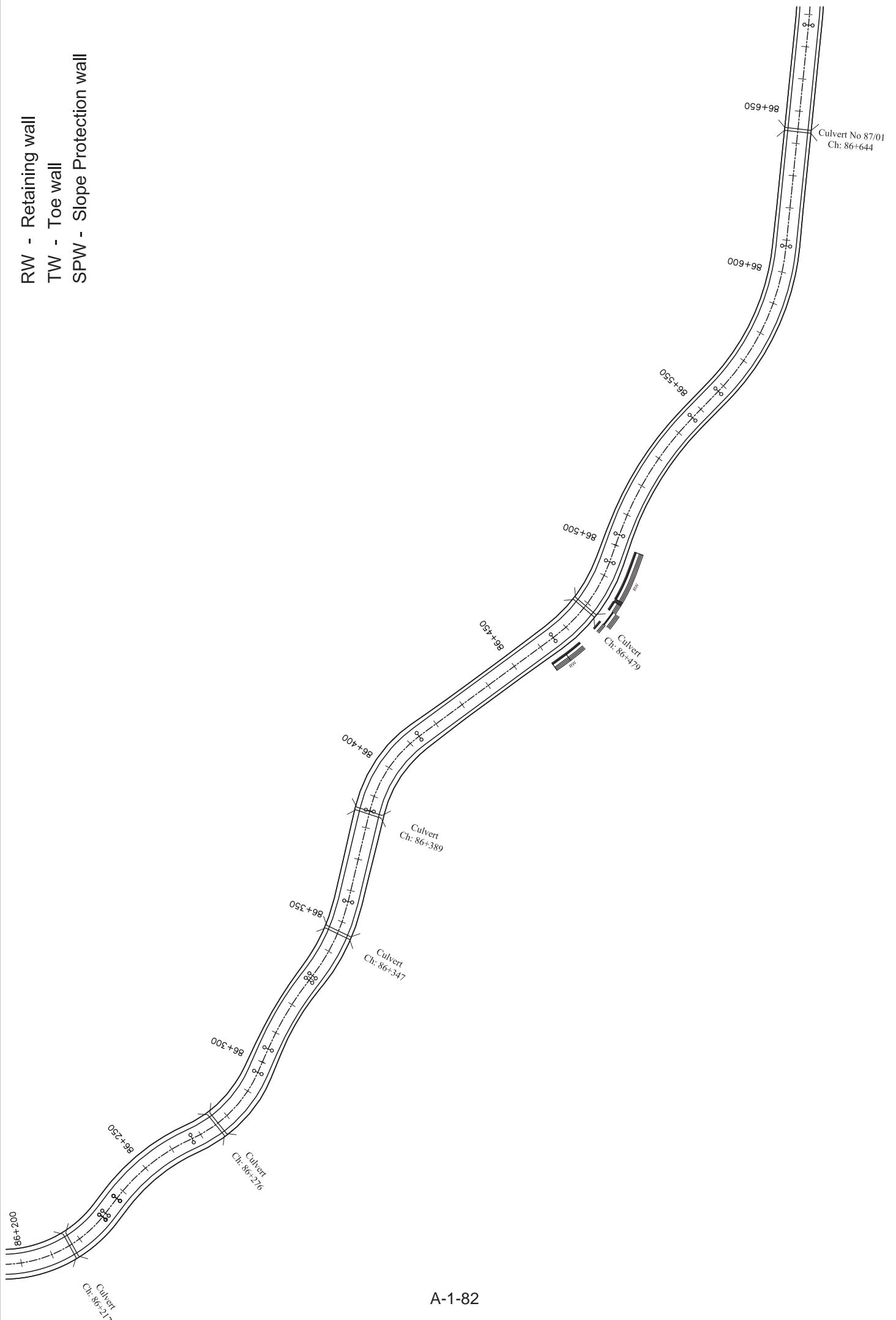

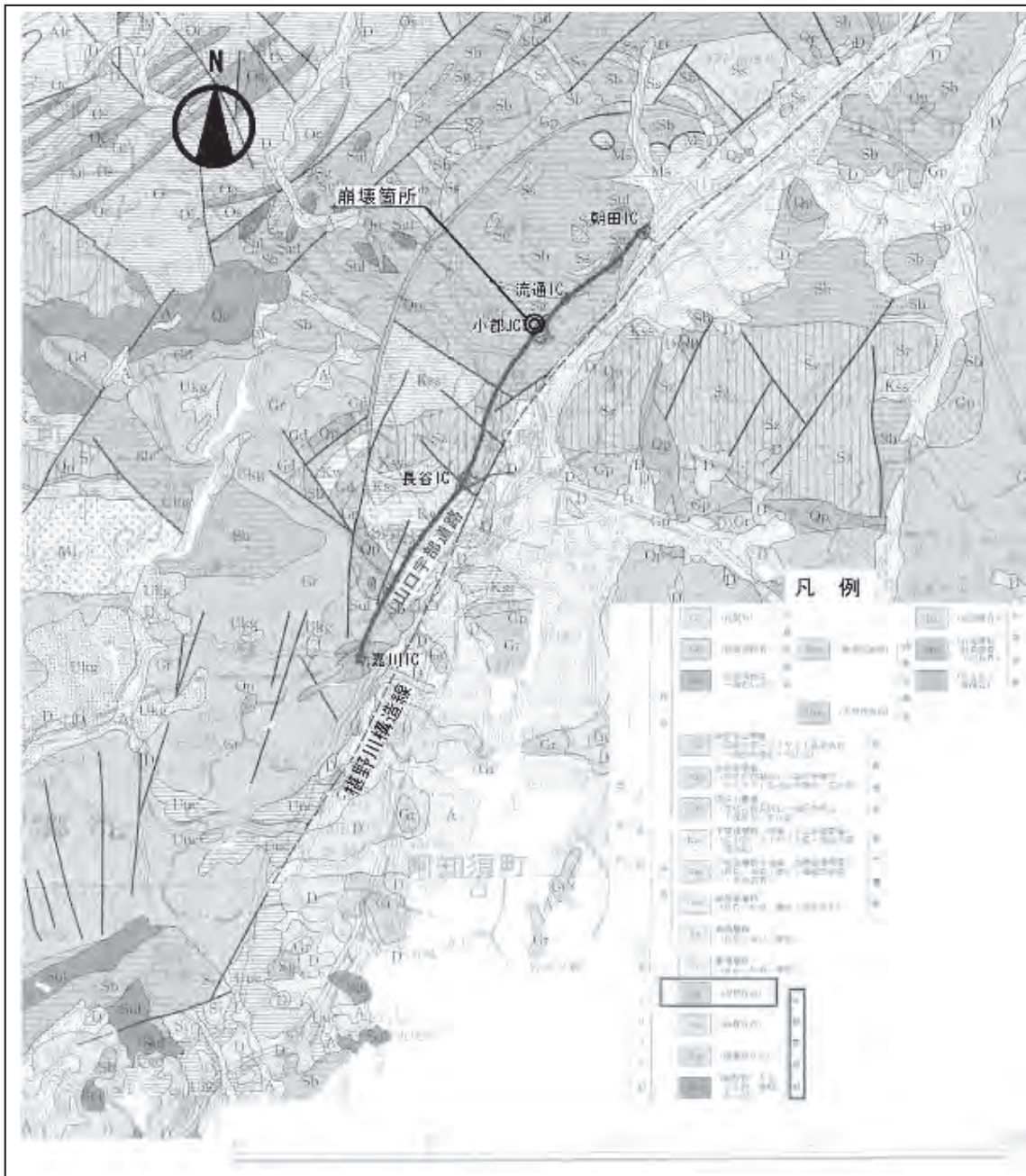

Ref: Report on research study of road slope collapse, Ube city, Yamaguchi prefecture,  
[http://www.pref.yamaguchi.lg.jp/cms/a18300/yamaguchiube/norimen/apd1\\_1\\_2012020828115156.p](http://www.pref.yamaguchi.lg.jp/cms/a18300/yamaguchiube/norimen/apd1_1_2012020828115156.pdf)  
 df , 5th Dec, 2012

**Image of the 1/10,000 Scale Map**

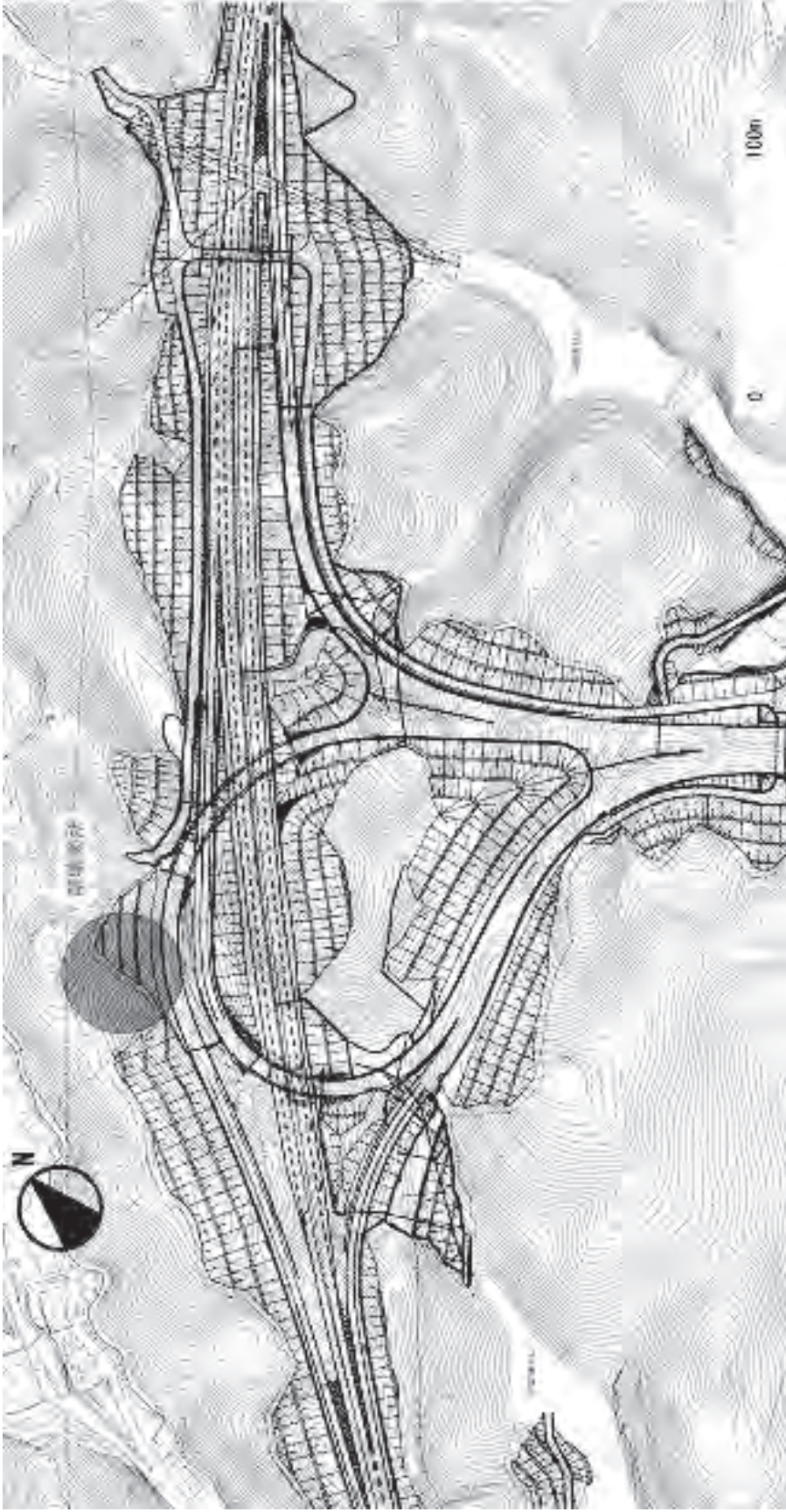

Ref: Report on research study of road slope collapse, Ube city, Yamaguchi  
prefecture,

[http://www.pref.yamaguchi.lg.jp/cms/a18300/yamaguchiube/norimen/apdl\\_1\\_2012020828115156.pdf](http://www.pref.yamaguchi.lg.jp/cms/a18300/yamaguchiube/norimen/apdl_1_2012020828115156.pdf) , 5th Dec, 2012

**Image of the 1/1,000 Scale Map**

## Checklist Form C (Screening) - Disaster Impact Assessment

### (A). Basic Information of the Road:

- a. Name of the Road: Kegalle Bulathkohupitiya Karawanella Road
- b. Road No / Code: A21
- c. Category of Road: **National** / Provincial / Municipal, Town / Village / Other
- d. Road Administration: Province / CE / EE Division/s: Sabaragamuwa Prov. Kegalle District, Kegalle EED
- e. Classification: E / **A** / B / C / D / Unclassified / New/ Other
- f. Road Section: 5Km (42 Km)
- g. Type of Project: New Construction / Widening & Improvement / **Rehabilitation of the existing road**

### (A.1) - Draft Map of examined site with location numbers:



(A.2). Site No/s.: 13/8-13/9 LHS&RHS, 16/5-16/6LHS, 16/10-16Km Post LHS&RHS

(A.3). Attach Map showing potential hazardous locations based on “beyond normal condition”

- (Map No.01 in Form B)

① Attached

(A.4). Attach Table with the details of above-mentioned locations

② Attached

**(B). Evaluation:****(B.1)-Evaluation of screened sites**

No.	(1) Site No.	(2) Requesting Agency for Inspection	(3) Comments <i>(Proposing Actions by EE / Engineer)</i> <i>Site specific remarks)</i>
1.	13/8-13/9LHS&RHS	NBRO	High Priority
2.	16/5-16/6LHS	NBRO	Priority
3.	16/10-16Km Post	NBRO	Urgent
4.			
5.			
6.			
7.			
8.			
9.			
10.			

**(B.2) - Comments**

Total length of KBK road is 42 km & from 0+000 to 16+000 is maintained by EE Kegalle. Between 11+000 and 16+000 Three Sites were taken in to the Sample.

**(B.3)- Details of the responsible officer (CE)**

Name of the CE		A.A. Senadeera	
Designation		Chief Engineer	
Division & Organization Address		CE Division, RDA, Kegalle	
Contact Details	Telephone	Office	0352229877
		Mobile	0714432504
		Fax	0352229877
Email Address			

Signature of CE: \_\_\_\_\_

Date:  
.....

Received:

PD : \_\_\_\_\_ Date: \_\_\_\_\_

D, MMC : \_\_\_\_\_ Date: \_\_\_\_\_

ADG, RDA : \_\_\_\_\_ Date: \_\_\_\_\_

1.1. Site No: 13/8-13/9 **LHS/ RHS** –Refer to the sites in draft map in section (A.1)  
 (LHS- Left Hand side; RHS- Right Hand side)

1.2. Inspection date/s: 15/10/2012

1.3. Road structure related to the site:

(1) Natural slope	<input type="checkbox"/>	(6) Drainage/ Canals	<input type="checkbox"/>
(2) Cut slope	<input checked="" type="checkbox"/>	(7) Road surface	<input type="checkbox"/>
(3) Embankment	<input type="checkbox"/>	(8) Others: Description : .....	<input type="checkbox"/>
(4) Retaining wall	<input checked="" type="checkbox"/>		
(5) Bridge	<input type="checkbox"/>		

1.4. Observable signs / features of the site, which may lead to hazardous / extreme conditions:

(1) No problem. Good condition	<input type="checkbox"/>	
(2) Soil and Concrete condition	<input checked="" type="checkbox"/>	Loose soil, No slope protection
(3) Collapse (broken) and crack	<input checked="" type="checkbox"/>	Slight collapse observed, High RF may trigger the situation
(4) Road surface condition	<input type="checkbox"/>	Road surface is Macadam
(5) Drainage structure condition / Cleaning condition (like blockage)	<input type="checkbox"/>	Culverts are sufficient to cope with surface & drain water. Need to provide built up drain at LHS drain

1.5. Condition of the above potential failure: Please describe briefly.

The cut slope & embankment with retaining wall are potential to failures with high rainfall conditions. Heavy Rainfall and Steep Slopes are the main factors of trigger the failures. At cut slope, the width of the slope 10m, height 10m, possible effective length 30m and gradient is at 45-60 degrees range. Planting grasses was already done as a remedial measure to control potential earth slips but required to reduce the gradient. At embankment, width of slope 50m height 50m and possible effective length 50m and gradient 45-60 degree range. As recommendation slope protection is required to keep same gradient at the embankment otherwise under high RF condition embankment and road surface collapse may be possible & road become impassable. Since there is no detour routes available, Inspections by NBRO for long term countermeasures is an urgent requirement.



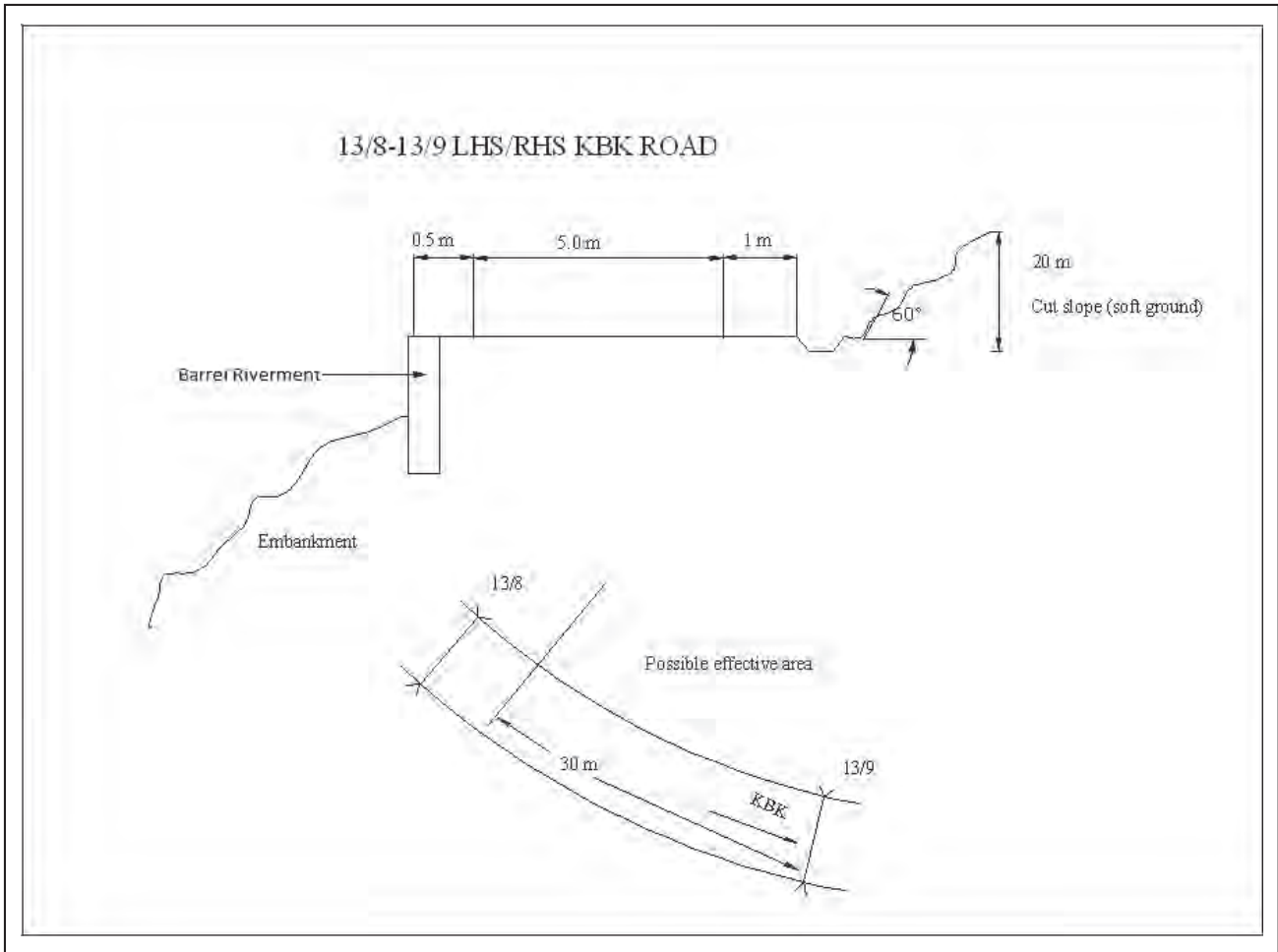

1.7. Photos of the Site:

Photo	Photo
<p>Comment</p>	<p>Comment</p>

Signature of EE:

Name of the EE: H.K.D.A.P. Kumarasiri

Evaluation

01. Needs of Inspection:                      Need  ✓              No Need

02. If it is checked "Need" at 01, please check the type of potential failure

(1) Rock fall / collapse	<input type="checkbox"/>	(6) Retaining wall failure	✓
(2) Slop failure / collapse	✓	(7) Culvert /canal/ drainage failure	<input type="checkbox"/>
(3) Landslide	✓	(8) Pavement	<input type="checkbox"/>
(4) Debris flow	<input type="checkbox"/>	(9) Problem of bridge	<input type="checkbox"/>
(5) Embankment failure	✓	(10) Others / Not sure	<input type="checkbox"/>