

**NATIONAL WATER SUPPLY & DRAINAGE BOARD (NWSDB)
MINISTRY OF WATER SUPPLY AND DRAINAGE
THE DEMOCRATIC SOCIALIST REPUBLIC OF SRI LANKA**

**PREPARATORY SURVEY
ON
ANURADHAPURA NORTH
INTEGRATED WATER SUPPLY PROJECT
IN
THE DEMOCRATIC SOCIALIST REPUBLIC
OF
SRI LANKA**

**FINAL REPORT
(VOLUME I : SUMMARY)**

FEBRUARY 2013

JAPAN INTERNATIONAL COOPERATION AGENCY

**NJS CONSULTANTS CO., LTD.
in Association with
NIHON SUIDO CONSULTANTS CO., LTD.**

| |
|--------|
| GE |
| CR (4) |
| 13-013 |

TABLE OF CONTENTS

TABLE OF CONTENTS

LIST OF TABLES

LIST OF FIGURES

| | |
|--|------------|
| CHAPTER 1 WATER SUPPLY SECTOR IN SRI LANKA | 1-1 |
| 1.1 Country Background | 1-1 |
| 1.2 Water Supply Undertakings (Service Ratios and Level)..... | 1-3 |
| 1.3 Sector Organization | 1-7 |
| 1.4 Financial Situation of the Sector..... | 1-8 |
| 1.5 Activities and Policies of International Development partners and National Agencies of the Sector | 1-13 |
| CHAPTER 2 NATURAL AND SOCIAL CONDITIONS | 2-1 |
| 2.1 General | 2-1 |
| 2.2 Natural Conditions | 2-2 |
| 2.2.1 Topography | 2-2 |
| 2.2.2 Geology..... | 2-2 |
| 2.2.3 Climate..... | 2-3 |
| 2.3 Social Conditions | 2-3 |
| 2.3.1 Population | 2-3 |
| 2.3.2 Land Use..... | 2-4 |
| 2.3.3 Income and Expenditure | 2-5 |
| 2.4 Economic Conditions | 2-6 |
| 2.4.1 Agriculture | 2-7 |
| 2.4.2 Industry | 2-7 |
| 2.4.3 Tourism | 2-7 |
| 2.5 Necessity of the Project..... | 2-8 |
| 2.5.1 General..... | 2-8 |
| 2.5.2 Dental Fluorosis..... | 2-12 |
| 2.5.3 Chronic Kidney Diseases (CKD)..... | 2-16 |
| 2.5.4 Necessity of the Project | 2-18 |
| CHAPETER 3 EXISTING WATER SUPPLY FACILITIES IN THE STUDY AREA ... | 3-1 |
| 3.1 Water Supply Schemes in Anuradhapura District | 3-1 |
| 3.2 Exist Water supply Facilities under NWSDB RSC (NC) | 3-3 |
| 3.2.1 Organizational..... | 3-3 |
| 3.2.2 Technical..... | 3-5 |
| 3.2.3 Financial | 3-7 |
| 3.2.4 Water Supply Development Plan of NWSDB RSC (NC)..... | 3-8 |
| 3.3 Existing Water Supply Facilities under NWSDB in the Study Area | 3-9 |
| 3.4 Existing Water Supply Facilities under CBOs in the Study Area..... | 3-10 |
| 3.4.1 General..... | 3-10 |
| 3.4.2 Summary of Survey Results | 3-14 |

| | | |
|--|---|------------|
| CHAPTER 4 PROJECTION OF POPULATION AND WATER DEMAND IN THE STUDY AREA | | 4-1 |
| 4.1 | Basic Policy for Planning | 4-1 |
| 4.2 | Estimation of Design Water Supply | 4-2 |
| 4.2.1 | Design Service Area | 4-2 |
| 4.2.2 | Design Period | 4-3 |
| 4.2.3 | Design Population | 4-3 |
| 4.2.4 | Demarcation of Design Service Area by Water Supply Mode | 4-4 |
| 4.2.5 | Existing CBOs to Be Excluded from Integration | 4-6 |
| 4.2.6 | Breakdown of Water Consumption | 4-6 |
| 4.2.7 | Per Capita Water Consumption | 4-6 |
| 4.2.8 | Non-revenue Water (NRW) | 4-7 |
| 4.2.9 | Design Served Population | 4-7 |
| 4.2.10 | Design Load Factor to Daily Maximum Water Supply | 4-7 |
| 4.2.11 | Design Daily Average and Maximum Water Supply and Design Water Intake | 4-8 |
| 4.2.12 | Design Flow of Water Treatment Plants for Stage Construction | 4-10 |
| 4.3 | Water Availability | 4-11 |
| 4.3.1 | Water Source | 4-11 |
| 4.3.2 | Water Quality | 4-11 |
| 4.3.3 | Present Operation of Irrigation Reservoir | 4-14 |
| 4.3.4 | Water Availability from Irrigation Reservoir | 4-18 |
| 4.3.5 | Mahakanadarawa Wewa | 4-20 |
| 4.3.6 | Wahalkada Wewa | 4-23 |
| 4.3.7 | Measures against Global Climate Change | 4-25 |
| CHAPTER 5 PLAN OF PROPOSED WATER SUPPLY SYSTEM..... | | 5-1 |
| 5.1 | Water Intake Works | 5-1 |
| 5.1.1 | Selection of Water Intake Methods | 5-1 |
| 5.1.2 | Design Criteria | 5-2 |
| 5.1.3 | Outline of Water Intake Facilities | 5-3 |
| 5.2 | Water Treatment Plant | 5-4 |
| 5.2.1 | Stage Construction of Water Treatment Plants | 5-4 |
| 5.2.2 | Selection of Water Treatment Process | 5-7 |
| 5.2.3 | Design Criteria | 5-10 |
| 5.2.4 | Mahakanadarawa WTP | 5-10 |
| 5.2.5 | Wahalkada WTP | 5-13 |
| 5.3 | Transmission and Distribution System | 5-16 |
| 5.3.1 | Description of Project Area | 5-16 |
| 5.3.2 | Planning Concept of the System | 5-17 |
| 5.3.3 | Design Criteria | 5-22 |
| 5.3.4 | Mahakandawara System | 5-23 |
| 5.3.5 | Wahalkada System | 5-24 |
| 5.3.6 | Distribution System | 5-26 |
| 5.3.7 | Major Facilities of Transmission and Distribution System | 5-27 |
| 5.4 | Mechanical Equipment | 5-33 |
| 5.4.1 | Design Criteria of Pumping Stations | 5-33 |
| 5.4.2 | Planning of Pump Station | 5-33 |
| 5.4.3 | Intake Facility | 5-33 |
| 5.4.4 | Pump | 5-33 |
| 5.4.5 | Electric Motor | 5-35 |
| 5.4.6 | Other Equipment | 5-35 |
| 5.4.7 | Measures against Water Hammer | 5-35 |
| 5.5 | Electrical Equipment | 5-36 |
| 5.5.1 | Electricity Power Supply | 5-36 |

| | | |
|-------|---|------|
| 5.5.2 | Power Generator | 5-37 |
| 5.5.3 | Low Voltage Facilities | 5-38 |
| 5.5.4 | Instrumentation Facilities | 5-38 |
| 5.5.5 | Monitor and Control Facilities..... | 5-39 |
| 5.6 | Water Supply System for Isolated Areas..... | 5-40 |

CHAPTER 6 MANAGEMENT, OPERATION AND MAINTENANCE OF PROPOSED WATER SUPPLY SYSTEM..... 6-1

| | | |
|-------|---|------|
| 6.1 | Project Implementation Organization | 6-1 |
| 6.1.1 | The National Water Supply and Drainage Board | 6-1 |
| 6.1.2 | The NWSDB RSC(N/C)..... | 6-2 |
| 6.1.3 | Project Implementation Arrangements | 6-2 |
| 6.1.4 | Capacity Development of the Implementation Organisation..... | 6-3 |
| 6.2 | Operation and Maintenance Organization | 6-4 |
| 6.2.1 | Additional O&M Staff/ Cadre for the Existing WWS in the Project Area | 6-6 |
| 6.2.2 | New O&M Cadre for the Mahakandarawa and Wahalkada Water Supply Scheme | 6-6 |
| 6.2.3 | Proposed O&M Area (Satellite) Office for the WSS in the Project Area | 6-6 |
| 6.2.4 | Enhancing Other Sections/ Units in Support of O&M | 6-6 |
| 6.2.5 | Supporting O&M through Equipment and Engineering Software..... | 6-6 |
| 6.3 | Mode of Water Supply Service | 6-7 |
| 6.3.1 | Community Based Organization..... | 6-7 |
| 6.3.2 | CBO Managed Water Supply Schemes in the Project Area..... | 6-7 |
| 6.3.3 | Approaches in Providing Water Supply Services to CBOs..... | 6-8 |
| 6.4 | Water Tariff Systems..... | 6-10 |
| 6.5 | Cost Sharing..... | 6-11 |

CHAPTER 7 PROJECT COST 7-1

| | | |
|-------|--|------|
| 7.1 | Preamble (Basis for Cost Estimation) | 7-1 |
| 7.2 | References for Unit Prices | 7-1 |
| 7.3 | Considerations for Preparing Cost Estimation | 7-2 |
| 7.4 | Project Cost Estimation | 7-4 |
| 7.4.1 | Eligible Cost | 7-8 |
| 7.4.2 | Non Eligible Cost..... | 7-12 |
| 7.5 | Operation and Maintenance Cost | 7-14 |

CHAPTER 8 PROJECT IMPLEMENTATION 8-1

| | | |
|-----|---------------------------------------|-----|
| 8.1 | Project Implementation Schedule | 8-1 |
| 8.2 | Contract Package | 8-2 |
| 8.3 | Procurement Method | 8-4 |
| 8.4 | Consulting Services (TOR) | 8-6 |

CHAPTER 9 ENVIRONMENTAL AND SOCIAL CONSIDERATION 9-1

| | | |
|-----|--|-----|
| 9.1 | Natural Conditions | 9-1 |
| 9.2 | Social Consideration | 9-3 |
| 9.3 | Human Resettlement and Land Acquisition..... | 9-3 |
| 9.4 | Scoping | 9-4 |
| 9.5 | Mitigation Measures | 9-5 |
| 9.6 | Environmental Check List | 9-8 |

CHAPTER 10 FINANCIAL AND ECONOMIC ANALYSIS 10-1

| | | |
|------|--|------|
| 10.1 | General..... | 10-1 |
| 10.2 | Social and Economic Conditions (Tariffs and Economic Situations) in Project Area | 10-1 |

| | | |
|---|--|-------------|
| 10.3 | Financial Analysis | 10-3 |
| 10.3.1 | Preconditions and Methods | 10-3 |
| 10.3.2 | FIRR Results..... | 10-3 |
| 10.4 | Economic Analysis | 10-4 |
| 10.4.1 | Preconditions and Methods | 10-4 |
| 10.4.2 | Benefits | 10-4 |
| 10.4.3 | EIRR Results | 10-5 |
| 10.5 | Toward Sustainability of Operation and Maintenance and What Water Supply Management Should be | 10-7 |
| CHAPTER 11 OPERATION AND EFFECT INDICATORS | | 11-1 |
| 11.1 | Operation Indicators | 11-1 |
| 11.2 | Effect Indicators | 11-2 |
| CHAPTER 12 PROJECT RISK..... | | 12-1 |
| 12.1 | Project Risk..... | 12-1 |
| 12.2 | Considerations in Planning | 12-3 |

LIST OF TABLES

| | | |
|---------------|---|------|
| Table 1.1 | Safe Water and Sewerage Coverage | 1-1 |
| Table 1.2 | City Water Supply 2020 | 1-1 |
| Table 1.3 | Strategic Approach | 1-2 |
| Table 1.4 | Planned Water Supply & Sewerage Coverage 2012 – 2016 | 1-3 |
| Table 1.5 | NWSDB Key Facts and Figures | 1-5 |
| Table 1.6 | NWSDB Progress Towards Stated Goals | 1-6 |
| Table 1.7 | Water Supply Sub Sector | 1-7 |
| Table 1.8 | Profit/ Loss of NWSDB | 1-10 |
| Table 1.9 (1) | Assets in Balance Sheet of NWSDB | 1-11 |
| Table 1.9 (2) | Equity and Liabilities in Balance Sheet of NWSDB | 1-12 |
| Table 1.10 | Bi- and Multi-lateral Assistance to Sectors in Sri Lanka | 1-13 |
| | | |
| Table 2.1 | Population, Population density and Growth Rate of Sri Lanka, Anuradhapura | 2-3 |
| Table 2.2 | Basic Data | 2-6 |
| Table 2.3 | Principal Source of Drinking Water in the Study Area (2001 & 2011) | 2-8 |
| Table 2.4 | Water-fetching Distance in Anuradhapura District | 2-9 |
| Table 2.5 | Water Quality of CBO's Supply System | 2-11 |
| Table 2.6 | Prevalence of CKD in Some Selected Area in Sri Lanka | 2-17 |
| | | |
| Table 3.1 | Water Supply Schemes in Anuradhapura District | 3-2 |
| Table 3.2 | Revenues and Expenditures of North Central Office | 3-8 |
| Table 3.3 | Existing Supply Schemes and Served Population | 3-9 |
| Table 3.4 | NWSDB Facilities (General Information) | 3-10 |
| Table 3.5 | Water Quality of NWSDB Facilities in the Area | 3-10 |
| Table 3.6 | Capacity of Elevated Tanks | 3-13 |
| Table 3.7 | Distribution Pipes | 3-13 |
| | | |
| Table 4.1 | Historical Census Population | 4-3 |
| Table 4.2 | Population Projection in the Study Area | 4-4 |
| Table 4.3 | Comparison of Three Options | 4-6 |
| Table 4.4 | Summary of Design Fundamentals | 4-8 |
| Table 4.5 | Annual Change in Design Daily Average and Maximum Water Supply and Design Water Intake | 4-9 |
| Table 4.6 | Design Flow for a Water Treatment Plant | 4-10 |
| Table 4.7 | Results of Laboratory Chemical and Microbiological Analysis for Proposed Water Sources | 4-12 |
| Table 4.8 | General Condition of the Irrigation | 4-15 |
| Table 4.9 | Irrigation Water Used in 2009-2011 | 4-16 |
| Table 4.10 | General Data of Mahakanadarawa and Wahalkada Tank | 4-16 |
| Table 4.11 | Gross Estimation of Water Balance | 4-19 |
| Table 4.12 | Water Supply for Drinking Water | 4-20 |
| Table 4.13 | Water Quality Results for Moragahakanda and Kalu Ganga Reservoirs | 4-24 |
| | | |
| Table 5.1 | Memorandum for Extracting Water | 5-2 |
| Table 5.2 | Design Criteria for Intake Facilities | 5-3 |
| Table 5.3 | FIRR Comparison between Stage and Full Constructions | 5-7 |
| Table 5.4 | Raw Water Quality | 5-8 |
| Table 5.5 | Odor of Raw Water | 5-8 |
| Table 5.6 | Results of the Jar Tests (Surface Water of Mahakanadarawa Tank) | 5-10 |

| | | |
|------------|---|------|
| Table 5.7 | Design Criteria | 5-10 |
| Table 5.8 | Capacity of Proposed WTP | 5-12 |
| Table 5.9 | Detail of Facilities | 5-13 |
| Table 5.10 | Capacity of Proposed WTP | 5-15 |
| Table 5.11 | Detail of Facilities | 5-15 |
| Table 5.12 | Summary of GNDs in Project Area | 5-18 |
| Table 5.13 | Covering Area of Elevated Tanks | 5-21 |
| Table 5.14 | Key Ground Elevation of Transmission System | 5-23 |
| Table 5.15 | Mahakanadarawa Transmission System | 5-23 |
| Table 5.16 | Wahalkada Transmission System | 5-25 |
| Table 5.17 | Summary of Pipelines of Transmission and Distribution System | 5-28 |
| Table 5.18 | Summary Table of the Facilities to Be Constructed | 5-29 |
| Table 5.19 | Major Facilities of Transmission and Distribution System | 5-30 |
| Table 5.20 | Comparison of Measure System | 5-35 |
| | | |
| Table 6.1 | Current Number of NWSDB NC RSC Personnel according to Section | 6-2 |
| Table 6.2 | Roles and Responsibilities of Project Organisations | 6-3 |
| Table 6.3 | Proposed Capacity Development Activities and Outputs | 6-4 |
| Table 6.4 | Staff Requirement for Operation and Maintenance after the Project Completion | 6-5 |
| Table 6.5 | Categorisation of CBOs Based on Willingness to Connect, Conditions Set and Technical Suitability | 6-8 |
| Table 6.6 | Manner of Providing Water Supply Services | 6-9 |
| Table 6.7 | Sample Analysis of Monthly Water Bill of CBO Households | 6-10 |
| Table 6.8 | Estimation of Revenue and Expenditure in Case of an Application of Bulk Supply Charge to Existing CBOs | 6-12 |
| | | |
| Table 7.1 | Excavation Unit Price with Different Soil Types | 7-3 |
| Table 7.2 | Committee Involvements According to Project Costs | 7-4 |
| Table 7.3 | Mahakanadarawa Estimated Project Costs (Stage -1) | 7-5 |
| Table 7.4 | Wahalkada Estimated Project Costs (Stage -1) | 7-5 |
| Table 7.5 | Mahakanadarawa Disbursement Schedule (Stage -1) | 7-6 |
| Table 7.6 | Wahalkada Disbursement Schedule (Stage -1) | 7-7 |
| Table 7.7 | Construction Cost per Package (Stage -1) | 7-8 |
| Table 7.8 | Cost for Water Bowsers and Water Elevated Tank in the Isolated Area | 7-9 |
| Table 7.9 | Mahakanadarawa Estimated Cost for Consulting Services (Stage -1) | 7-11 |
| Table 7.10 | Wahalkada Estimated Cost for Consulting Services (Stage -2) | 7-12 |
| Table 7.11 | Estimated Cost for Proposed Land Acquisition/ Resettlement | 7-13 |
| Table 7.12 | Distribution Sub System and Service Connections | 7-14 |
| Table 7.13 | Operation and Maintenance NWSDB (NC) and Thuruwila WTP in 2011 | 7-15 |
| Table 7.14 | Electricity and Chemical Consumption per Cubic Meter | 7-15 |
| Table 7.15 | Salary of Staff required for the Proposed Water Supply System | 7-16 |
| Table 7.16 | Electricity Consumption for the Proposed Water Supply System | 7-16 |
| Table 7.17 | Chemical Consumption for the Proposed Water Supply System | 7-16 |
| Table 7.18 | Repair and Maintenance Cost for the Proposed Water Supply System | 7-17 |
| Table 7.19 | Operation and Maintenance Cost for the Proposed Water Supply System | 7-17 |
| | | |
| Table 8.1 | Proposed Project Implementation Schedule | 8-1 |
| Table 8.2 | Proposed Contract Package for Mahakanadarawa Project | 8-3 |
| Table 8.3 | Proposed Contract Packages for Wahalkada Project | 8-3 |
| | | |
| Table 9.1 | Scoping Result | 9-4 |
| Table 9.2 | List of Adverse Impacts and Its Mitigation Measures | 9-5 |
| Table 9.3 | Environmental Checklist | 9-9 |

| | | |
|------------|--|------|
| Table 10.1 | EIRR of Mahakandarawa Case 1 (With Phase 2 Investment) | 10-6 |
| Table 10.2 | Mahakandarawa Sensitivity Analysis Results | 10-6 |
| Table 11.1 | Operation Indicators for Water Supply | 11-4 |
| Table 11.2 | Fluorosis Risk Avoidance Rate | 11-2 |
| Table 11.3 | Effect Indicators for Water Supply | 11-6 |

LIST OF FIGURES

| | | |
|-------------|---|------|
| Figure 2.1 | Location Map of the Study Area | 2-1 |
| Figure 2.2 | Distribution for Fluoride Concentration of Groundwater in Sri Lanka | 2-13 |
| Figure 2.3 | Fluoride Results for CBO Supply Water (Horizontal Distribution) | 2-14 |
| Figure 2.4 | Comparison of CFI | 2-15 |
| Figure 2.5 | District-wise of CFI | 2-16 |
| Figure 2.6 | DSD-wise Distribution of CKD in North Central | 2-18 |
| Figure 3.1 | Water Supply Schemes under NWSDB and CBOs in Anuradhapura District | 3-1 |
| Figure 3.2 | Distribution Map of CBO Facilities | 3-12 |
| Figure 4.1 | Flowchart of Design Water Supply Estimation | 4-2 |
| Figure 4.2 | Option 1 (No. of Isolated Areas: 47 GNDs) | 4-5 |
| Figure 4.3 | Service Area by Pipe Borne and Bowser Water Supply | 4-10 |
| Figure 4.4 | Water Quality (Fluoride) | 4-14 |
| Figure 4.5 | Monthly Rainfall and Storage in Mahakanadarawa Tank | 4-17 |
| Figure 4.6 | Monthly Rainfall and Storage in Wahalkada Tank | 4-17 |
| Figure 4.7 | Image of Water Balance | 4-18 |
| Figure 4.8 | Image of Assumed Additional Water from NCP Project | 4-21 |
| Figure 4.9 | Water Availability in the Mahakanadarawa Wewa | 4-21 |
| Figure 4.10 | NCP Canal Development Project Location Map | 4-22 |
| Figure 4.11 | Water Flow from Both Reservoirs to Mahakanadarawa | 4-23 |
| Figure 4.12 | Image of Assumed Additional Water from Yan Oya Project | 4-25 |
| Figure 4.13 | Water Availability in the Wahalkada Wewa | 4-25 |
| Figure 5.1 | Outline of Intake Facility in Mahakanadarawa Wewa | 5-4 |
| Figure 5.2 | Outline of Intake Facility in Wahalkada Wewa | 5-4 |
| Figure 5.3 | Situation of Housing Unit Distribution | 5-9 |
| Figure 5.4 | Flow Diagram of Mahakanadarawa WTP | 5-11 |
| Figure 5.5 | Layout of Mahakanadarawa WTP | 5-11 |
| Figure 5.6 | Layout of Wahalkada WTP | 5-14 |
| Figure 5.7 | Schematic of Project Area..... | 5-17 |
| Figure 5.8 | Water Supply Area by New Systems | 5-20 |
| Figure 5.9 | Schematic Flow Diagram of the Mahakanadarawa System | 5-24 |
| Figure 5.10 | Schematic Flow Diagram of the Wahalkada System | 5-25 |
| Figure 5.11 | Definitive Diagram of Distribution Systems | 5-26 |
| Figure 5.12 | Summery Diagram of the Facilities to be Constructed | 5-30 |
| Figure 5.13 | Water Supply System in Isolated Area | 5-40 |
| Figure 6.1 | Operation and Maintenance Organisation after the Project Completion | 6-5 |
| Figure 8.1 | Implementation Schedule | 8-2 |

ABBREVIATIONS

| | |
|----------------|--|
| AC pipe | Asbestos Cement Pipe |
| ADB | Asian Development Bank |
| AIA | Archaeological Impact Assessment |
| ANIWSP | Anuradhapura North Integrated Water Supply Project |
| BIQ | Basic Information Questionnaire |
| CBO | Community-Based Organization |
| CEA | Central Environmental Authority, the Ministry of Environment and Natural Resources (ME&NR) |
| CEB | Ceylon Electric Board |
| CFI | Community Fluorosis Index |
| CKD | Chronic Kidney Diseases |
| CMC | Colombo Municipal Council |
| CRM | Certified Reference Material |
| CWSSP | Community Water Supply and Sanitation Program |
| DI pipe | Ductile Iron Pipe |
| DSD | Divisional Secretary Division |
| EA | Engineering Assistant |
| EIA | Environmental Impact Assessment |
| EIRR | Economic Internal Rate of Return |
| EOI | Expression of Interest |
| ET | Elevated Tank |
| FB | Freeboard |
| FC | Foreign Currency |
| FIRR | Financial Internal Rate of Return |
| FR | Forest Reserve |
| FSD | Full Supply Depth |
| FSL | Full Storage Level |
| GND | Grama Niladhari Division |
| GOJ | Government of Japan |
| GOSL | Government of Sri Lanka |
| GPRS | General Packed Radio Service |
| HH | Household |
| HWL | High Water Level |
| ID | Irrigation Department |
| IDP | Internally Displaced Persons |
| IEE | Initial Environmental Examination |
| IFRC | International Federation of Red Cross and Red Crescent Societies |
| JICA | Japan International Cooperation Agency |
| KfW | German Government-owned Development Bank, (Kreditanstalt für Wiederaufbau) |
| NC | North Central |
| LA | Local Authority |
| LAA | Land Acquisition Act |
| LB | Left Bank |
| LC | Local Currency |
| LCD | Liquid Crystal Display |
| Lpcd | Litre per capita per day |
| LWL | Low Water Level |
| MCB | Miniature Circuit Breaker |
| MCC | Motor Control Centre |

| | |
|-----------------|---|
| MCCB | Molded Case Circuit Breaker |
| MCGs | Mahinda Chintana Goals |
| MCM | Million Cubic Meter (1,000,000 m ³) |
| MDGs | Millennium Development Goals |
| MWSD | Ministry of Water Supply and Drainage |
| NABL | National Accreditation Board for Testing and Calibration Laboratories |
| N/C | North Central |
| NCP | North Central Province |
| ND | Nominal Diameter |
| NEA | National Environmental Act |
| NEP | National Environmental Policy |
| NHWA | National Heritage Wilderness Area |
| NIRP | National Involuntary Resettlement Policy |
| NRW | Non Revenue Water |
| NWSDB | National Water Supply and Drainage Board |
| OIC | Officer-in-Charge |
| PAA | Project Approving Agency |
| PCC | Project Coordination Committee |
| PCV pipe | Un-plasticized Polyvinyl Chloride Pipe |
| PD | Project Director |
| PEA | Project Executing Agency |
| PE pipe | Polyethylene Pipe |
| PLC | Programmable Logic Controller |
| PMU | Project Management Unit |
| PR | Proposed Reserve |
| PS | Pump Station |
| RAP | Resettlement Action Plan |
| RSC(N/C) | Regional Support Centre (North Central) |
| RSF | Rapid Sand Filter |
| RWS | Rural Water Supply |
| SCADA | Supervisory Control and Data Acquisition |
| SIDA | Swedish International Development Agency |
| SLAB | Sri Lanka Accreditation Board |
| SP | Steel Pipe |
| SSF | Slow Sand Filter |
| TEC | Technical Evaluation Committee |
| UDA | Urban Development Authority |
| UNICEF | United Nations International Children's Emergency Fund |
| UPS | Uninterruptible Power Systems |
| VPN | Virtual Private Network |
| VSD | Variable Speed Drive |
| WB | World Bank |
| WFP | Work and Financial Plan |
| WHO | World Health Organization |
| WLPSA | Wildlife Protected Area |
| WSP | Water Supply Project |
| WSS | Water Supply Scheme |
| WTP | Water Treatment Plant |
| Ac | = 4,047 m ² |
| Acft | = 1,234 m ³ |

CHAPTER 1 WATER SUPPLY SECTOR IN SRI LANKA

1.1 National Development Plan and Sector Development Plan

(1) National Development Plan (Mahinda Chintana - Vision for the Future)

“Mahinda Chintana - Vision for the Future”, or the Five-year Plan of Sri Lanka, which was declared in August 2010, covering a period of 2011 to 2016 is articulated identifying specific targets aiming at achieving the Millennium Development Goals (MDGs) ahead of time. Among Mahinda Chintana Goals (MCGs) for 2016 include the following with other targets as shown in **Table 1.1**, toward “*Increasing access to clean water in urban areas from 65 to 90 percent*”.

Table 1.1 Access to Safe Water Coverage

| Year | 2005 | 2009 | 2015 | 2020* |
|---|------|-------|-------|-------|
| Safe water coverage (%) | 80 | 85 | 94 | 100 |
| Pipe borne water availability (%) | 29 | 37 | 44 | 60 |
| Water connections ('000) (NWSDB schemes) | 907 | 1,267 | 1,600 | 3,000 |

Source: “Mahinda Chintana – Vision for the Future”, Department of National Planning, Ministry of Financing and Planning, 2010

Mahinda Chintana also gives a strategic approach to “City Water Supply 2020” as shown in **Table 1.2**.

For the emerging metro centres and large townships as shown in **Table 1.3**, water supply and sewerage related infrastructure assets will be created to cater for the long-term and growing demands:

Table 1.2 City Water Supply 2020

| | |
|-----------------------------|--------|
| Affordability | |
| Per capita consumption | |
| Average tariff | |
| Production cost | |
| Quality | |
| Quality compliance | |
| Treatment facilities | |
| Breakdown frequency | |
| Reliability | |
| Hours of supply | 24 hrs |
| City coverage | 100% |
| Efficiency | |
| Non revenue water | 20% |
| Staff per 1,000 connections | 5 |
| Customer complaints | No |

| | |
|----------------------|------|
| Response to requests | 100% |
|----------------------|------|

Source: "Mahinda Chintana – Vision for The Future", Department of National Planning, Ministry of Financing and Planning, 2010

Table 1.3 Strategic Approach

| | |
|------------------------|--|
| Emerging metro centres | Kandy, Hambantota, Trincomalee, Dambulla, Jaffna, Galle, Gampaha, Kurunegala, Nuwara Eliya |
| Large Township | Vanuviya, Badulla, Matara, Anuradhapura, Ratnapura |

Source: "Mahinda Chintana – Vision for The Future", Department of National Planning, Ministry of Financing and Planning, 2010

(2) National Policy on Drinking Water (Updated on June 2009)

In the National Policy on Drinking Water, "1.5 Principles of the Policy" includes the following nine principles.

- i) Access to safe drinking water is a basic human right with commensurate responsibilities on the recipients.
- ii) Planning and development will be people centered, participatory and demand responsive.
- iii) The government acts as the custodian for the protection and proper management of drinking water resources.
- iv) Abstraction of water and the protection of the resource shall be carried out in recognition of downstream impacts.
- v) Where issues arise relating to competing demands, drinking water needs will have priority over the others, with reasonable consideration for other important needs.
- vi) Development of drinking water supplies and distribution of water to people shall be done efficiently and equitably.
- vii) Piped water supplies will be provided to populations/communities where other supply arrangements are inadequate.
- viii) The operational activities will be decentralized to the lowest appropriate level, giving due consideration to the capacity and efficiency.
- ix) Water safety will be practiced at all levels and ensured by all parties.

Among others, v) is most important as it gives the first priority to drinking water over others.

The following ideas in "5.0 Cost Recovery" attract attention:

- The following cost components of processing and delivery will be recovered through a service charge.
 - capital cost and interest incurred
 - operation and maintenance cost
 - replacement and rehabilitation cost

- In consideration of the lifeline requirement a subsidy shall be provided to the poor and marginalized communities.
- The cost recovery system shall be applicable and be implemented uniformly within respective administrative boundaries.

The above suggests full cost recovery, consideration for the poor and allowance for different water tariffs compared to the current situation where there is a uniform tariff throughout the whole of the country.

(3) NWSDB Corporate Plan 2012-2016 (Draft)

In response to “Mahinda Chintana”, NWSDB has prepared a draft “Corporate Plan 2012 – 2016” to clarify their principles and values, functions, goals and objectives and strategies.

NWSDB is not covering the whole of the drinking water sector in the country and part of this provision will be done by some Local Authorities and other organizations as described in “**1.2.4 Sector Organization**”. As shown in **Table 1.4**, NWSDB plans to supply about 40% of the population in 2016 with a pipe borne water supply, compared to about 52% of the total population served. However the above figures are not consistent with the pipe borne water availability of 44% in 2015 in “Mahinda Chintana”

Table 1.4 Planned Water Supply & Sewerage Coverage 2012 - 2016

| Year | 2011 | 2012 | 2013 | 2014 | 2015 | 2016 |
|--|------------|------------|------------|------------|------------|------------|
| Population | 20,861,045 | 21,069,655 | 21,280,352 | 21,493,156 | 21,708,087 | 21,925,168 |
| Pipe borne water supply coverage | 9,074,555 | 9,523,484 | 10,001,765 | 10,488,660 | 10,984,292 | 11,488,788 |
| NWSDB pipe borne water supply connected coverage (%) | 33.00% | 34.50% | 36.00% | 37.40% | 38.90% | 40.40% |
| Overall pipe borne water supply connected coverage (%) | 43.50% | 45.20% | 47.00% | 48.80% | 50.60% | 52.40% |
| Pipe borne sewerage coverage** | 479,804 | 505,672 | 532,009 | 558,822 | 586,118 | 613,905 |
| Pipe borne sewerage coverage (%) | 2.30% | 2.40% | 2.50% | 2.60% | 2.70% | 2.80% |

Source: NWSDB, “Corporate Plan 2012 – 2016 (Draft)”

1.2 Water Supply Undertakings (Service Ratios and Level)

The present situation of water supply service under NWSDB is summarised as shown in **Table 1.5** and **Table 1.6**, respectively.

Findings are as follows:

- The population coverage under NWSDB control was 36.9% as of December 2009.
- The total number of connections was 1,353,573, out of which 349,372 (25.8%) were in the Central area, 164,259 (12.1%) in the Western-central area, 163,335 (12.1%) in the Western-south area and 141,601 (10.5%) in the Western-north area. Colombo and Kandy, as well as the areas surrounding both cities account for 60.5% of the total number of connections.
- The NRW ratio ranged from 13.8% in the North-eastern area to 37.8% in Sabaragamuwa, whereas in the Colombo Municipal Council (CMC) area it was 53.05%, which is significantly higher than the national average of 32.1%.
- The number of staff per 1,000 connections was lowest in the Western-central area (Colombo) at 2 followed by 4.2 in the Western-south area (Kalutara), 5 in the Western-north area (Gampaha) and 6 in the Central (Kandy, Matale and Nuwala Eliya) and North-central (Anuradhapura and Polonnaruwa) area. Uva has the highest number of staff per 1,000 connections at 27.4. As shown in **Table 1.6**, for the whole of NWSDB, the number of staff per 1,000 connections decreased steadily from 8.2 in 2007 to 7.5 in 2008 and 7.2 in 2009.
- Water availability or the time of water supply is worst at 3.7 hours per day in the Northern area followed by 9.6 hours in Uva, 10.9 hours in the Eastern area, 12.0 hours in the Western-south area and 12.9 hours in the North-western area. In the case of the Northern area, the damage caused by the conflict, which ended in 2009 is significant.
- The average tariff exceeds the production cost in only three out of 11 regions. The average tariff of the Western-central area (Colombo) is 2.56 times the production cost followed by 1.26 times in the Western-south area (Kalutara) and 1.15 times in the Central area (Kandy, Matale and Nuwala Eliya). On the contrary, in the Northern and North-western areas the average tariff is 0.45 times and 0.48 times the production cost, respectively.
- As shown in **Table 1.6**, the percentage of the number of estimated bills to total bills decreased from 12% in 2007 to 7% in both 2008 and 2009, but this figure is still high.
- Per capita consumption ranges from 94.0 Lpcd in Uva to 138.5 Lpcd in Sabaragamuwa.
- The collection period of accounts receivables has improved from 60 days for domestic and commercial institutions and 65 days for government institutions in 2008 to 55 days and 44 days, respectively, in 2009, with the improvement for government institutions being significant (refer to **Table 1.6**).

Table 1.5 NWSDB Key Facts and Figures

| Service Indicators | Regional Support Centre (Regional Average) | | | | | | | | | | | | | | | | | | | | | | |
|--|--|---------|-------------------|---------|-----------------|--------|---------|---------|-----------------|--------|-----------------|------|--------------|------|----------|------|------|------|----------|------|---------|------|--|
| | Western - North | | Western - Central | | Western - South | | Central | | North - Western | | North - Central | | Sabaragamuwa | | Southern | | Uva | | Northern | | Eastern | | |
| | 2008 | 2008 | 2008 | 2009 | 2008 | 2008 | 2009 | 2008 | 2008 | 2008 | 2008 | 2008 | 2008 | 2008 | 2008 | 2008 | 2008 | 2008 | 2008 | 2008 | 2008 | 2008 | |
| Number of Connections (As of December 2010) | 141,401 | 164,259 | 163,335 | 349,372 | 40,947 | 62,579 | 69,264 | 203,820 | 56,771 | 6,456 | 95,169 | | | | | | | | | | | | |
| 1 Service Standard Indicators | | | | | | | | | | | | | | | | | | | | | | | |
| Water Coverage (%) Pipe System maintained by NWSDB | 25.1% | 33.5% | 48.4% | 29.4% | 5.9% | 16.9% | 9.3% | 35.1% | 16.2% | 3.8% | 23.9% | | | | | | | | | | | | |
| Per Capita Consumption (l/c/d) | 117.1 | 125.7 | 122.3 | 101.3 | 99.7 | 103.2 | 138.5 | 103.6 | 94 | 116.7 | 79.7 | | | | | | | | | | | | |
| Water Availability (hours) | 21.4 | 23.2 | 12 | 22 | 12.9 | 24 | 18.6 | 22.4 | 9.6 | 3.7 | 10.9 | | | | | | | | | | | | |
| Water Quality - Bacteriological Quality Compliance | 94.7% | n/a | 95.1% | 97.7% | 97.7% | 99.7% | 92.8% | 96.5% | 94.1% | 96.2% | 96.2% | | | | | | | | | | | | |
| Water Quality - Bacteriological Testing Compliance | 100.0% | n/a | 100.0% | 83.3% | 100.0% | 100.0% | 100.0% | 100.0% | 100.0% | 100.0% | 100.0% | | | | | | | | | | | | |
| Water Quality - All Samples Compliance | 95.8% | n/a | 99.5% | 95.7% | 40.9% | 94.4% | 98.3% | 84.8% | 71.2% | 96.3% | 88.8% | | | | | | | | | | | | |
| Sewerage Coverage (%) | 2.5% | 0.0% | 2.3% | 0.1% | - | - | - | 0.3% | - | - | - | | | | | | | | | | | | |
| 2 Operational Indicators | | | | | | | | | | | | | | | | | | | | | | | |
| Non-Revenue Water (%) | 24.1% | 33.5% | 33.0% | 32.5% | 13.8% | 19.8% | 37.8% | 30.5% | 30.0% | 16.4% | 32.9% | | | | | | | | | | | | |
| Non-Revenue Water - m ³ /conn/day | 0.23 | 0.49 | 0.32 | 0.20 | 0.10 | 0.16 | 0.28 | 0.27 | 0.23 | 0.12 | 0.27 | | | | | | | | | | | | |
| Defective Meters per '000 connections | 51 | 15 | 23 | 16 | 8 | 48 | 44.9 | 17.3 | 124.6 | 22 | 29 | | | | | | | | | | | | |
| Total Staff/ 1000 connection | 5 | 2 | 4.2 | 6 | 9 | 6 | 7.4 | 6.5 | 27.4 | 20 | 11 | | | | | | | | | | | | |
| Operational Staff/ 1000 connection | 3 | 2 | 4.1 | 5 | 8 | 6 | 6 | 3.5 | 25.4 | 15 | 10 | | | | | | | | | | | | |
| Estimated Bills/ 1000 connections | 126 | 53 | 80 | 33 | 18 | 112 | 18.9 | 44.9 | 186.4 | 168 | 89 | | | | | | | | | | | | |
| 3 Performance in Customer Service | | | | | | | | | | | | | | | | | | | | | | | |
| Response to requests for new service connections (%) | 95.8% | 94.8% | 90.0% | 100.0% | 100.0% | 100.0% | 94.6% | 90.2% | 90.8% | 76.9% | 62.2% | | | | | | | | | | | | |
| Customer Complaints Volume (Complaints/ 1000 connection) | 109.1 | 13.5 | 219.3 | 135 | 56.6 | 11.1 | 34.9 | 127.7 | 230 | 17.7 | 7.1 | | | | | | | | | | | | |
| Customer Complaints Resolution | 86.2% | 91.6% | 33.0% | 94.5% | 86.9% | 91.1% | 94.3% | 86.3% | 67.5% | 83.3% | 81.4% | | | | | | | | | | | | |
| 4 Key Performance Indicators (KPIs) | | | | | | | | | | | | | | | | | | | | | | | |
| Collection Ratio (%) | 102.0% | 98.7% | 99.0% | 110.0% | 99.1% | 102.9% | 99.7% | 99.3% | 97.4% | 78.4% | 97.1% | | | | | | | | | | | | |
| Accounts Receivable Period (months) | 4.2 | 2.6 | 4.8 | 1.4 | 1.6 | 3.1 | 3.8 | 3.0 | 3.3 | 7.2 | 4.2 | | | | | | | | | | | | |
| Collectable Accounts Receivable Period (months) | 1.4 | 1.7 | 1.5 | 0.4 | 0.1 | 1.8 | 1.7 | 1.2 | 1.3 | 2.9 | 2.6 | | | | | | | | | | | | |
| Operating Ratio | 1.01 | 0.54 | 1.02 | 1.00 | 1.69 | 0.98 | 1.42 | 1.26 | 1.34 | 1.98 | 1.57 | | | | | | | | | | | | |
| Production Cost (LKR/ m ³ Produced) | 17.08 | 11.42 | 15.36 | 19.60 | 31.70 | 25.71 | 24.60 | 21.52 | 24.42 | 56.46 | 25.35 | | | | | | | | | | | | |
| Average Tariff (LKR/ m ³ Sold) | 16.68 | 29.25 | 19.30 | 22.50 | 15.31 | 21.20 | 20.71 | 16.32 | 18.68 | 25.64 | 15.59 | | | | | | | | | | | | |
| Stock Efficiency (LKR/ connection) | 2,189 | 1,323 | 1,790 | 2,602 | 2,672 | 3,754 | 1,888 | 2,227 | n/a | n/a | 2,528 | | | | | | | | | | | | |

Source: NWSDB Website

Table 1.6 NWSDB Progress Towards Stated Goals

| Goal | Key Objectives | Target end 2007 | Achievement end 2007 | Target end 2008 | Achievement end 2008 | Target end 2009 | Achievement end 2009 |
|---|---|--------------------|----------------------|--------------------|----------------------|--------------------|----------------------|
| 1. Increase WS and sanitation coverage | 1.1 Pipe-borne water supply coverage | 32.0% | 32.0% | 33.9% | 34.0% | 37.5% | 36.9% |
| | 1.2 Piped sewerage coverage | 2.5% | 2.4% | 2.6% | 2.4% | 2.7% | 2.5% |
| | 1.3 Access to safe drinking water supply coverage | 76.4% | 77%* | 77.6% | 78.0%* | 79.5% | 80.0%* |
| | 1.4 Total sanitation coverage | | 83.2%* | | 85.7%* | | 85.7%* |
| 2. Improve operational efficiency | 2.1 NRW (island-wide) | 33.0% | 33.09% | 33.0% | 32.1% | 32.0% | 31.1% |
| | 2.2 Total staff for 1,000 connections | 8.3 | 8.2 | 7.8 | 7.6 | 7.5 | 7.2 |
| | 2.3 Expenditure on power to total recurrent cost | 23.0% | 22.7% | 23.0% | 24.3% | 23.0% | 22.6% |
| | 2.4 Maintenance expenses to total recurrent cost | 7.5% | 5.11% | 7.5% | 4.1% | 7.0% | 4.7% |
| | 2.5 Establishment expenses to total recurrent cost | 10.5% | 9.5% | 10.5% | 10.9% | 10.0% | 10.7% |
| 3. Achieve customer satisfaction | 3.1 Public awareness programmes to be carried out (schools/other) | 20 Nos. | 12 Nos. | 30 Nos. | 32 Nos. | 30 Nos. | 37 Nos. |
| | 3.2 Complaints unresolved to total received | 10.0% | 7.3% | 9.0% | 7.3% | | |
| | 4.1 % of estimated bills to total number of bills | 10% | 12% | 10% | 7% | 8% | 7% |
| 4. Increase commercial viability | 4.2 Collection efficiency 100% | 100% | 100% | 100% | 99% | 100% | 94% |
| | 4.3 Accounts receivable from - (a) domestic and commercial institutions (b) Government institutions | 60 days 65 days | 60 days 65 days | 60 days 60 days | 60 days 65 days | 60 days 60 days | 55 days 44 days |
| 5. Ensure greater accountability | Initiatives were taken to develop a whole range of management and business tools on human resource development, management information system and business plan.# | | | | | | |
| | • Delegation of financial authority | | | | | | |
| | • Training on budgetary control & financial regulations | | | | | | |
| | • Audits on commercial operations | | | | | | |
| | • Audits on stores and supplies | | | | | | |
| | • Audits on cash/ cheque payments | | | | | | |
| | • Audits on construction contracts | | | | | | |
| | • Valuation of assets | | | | | | |
| | • Improved Management Information and Coordination | | | | | | |
| | 6.1 In-house training programmes | 150 | 113 | 150 | 105 | 160 | 110 |
| 6.2 In-country external training (no. of persons) | 240 | 258 | 240 | 272 | 250 | 170 | |
| 6.3 Overseas training (no. of persons) | 75 | 68 | 75 | 129 | 80 | 115 | |
| 7.1 Rural water supply by the NWSDB (managed by CBOs) | 4.5% | 4.5% | 4.5% | 4.0% | 5.0% | 4.5% | |

* Estimated as 83.1% for water supply and 96.7% for sanitation from a sample survey carried out during 2006-2007 by the Department of Census and Statistics excluding Jaffna, Kilinochchi, Mullaitivu, Mannar and Vavuniya districts.

* The Merchant Bank of Sri Lanka has been selected to prepare the Business Plan; The draft plan prepared was presented to the senior Management of NWSDB for comments. Under ADB Technical Assistance 7078, separate business plan are being prepared for RSCs for decentralized service delivery in the water sector.

Source: NWSDB, "Annual Report 2007 - 2009"

1.3 Sector Organizations

The water supply sector is divided into two sub sectors as shown in **Table 1.7**.

Table 1.7 Water Supply Sub Sector

| | Urban water supply sub sector | Rural water supply sub sector |
|--------------------|--|---|
| Object area | Towns, cities, urban centres, industries and suburban areas | Rural areas |
| Key Actors | Ministry of Water Supply and Drainage NWSDB Provincial Councils Municipal Councils Urban Councils Pradeshiya Sabhas | Provincial Councils Local Authorities Community Based Organizations (CBOs) Non-Government Organizations (NGOs) |
| Water service mode | Pipe borne water supply | Dug wells Tube wells Rain water harvesting Small-scale pipe water supply |

Source: "National Policy on Drinking Water", June 2009

Note: From Wikipedia

For the urban area, NWSDB is responsible for the provision of water supply through the implementation of large scale water supply, in consultation with relevant local authorities under the superintendence and direction of the Ministry of Water Supply and Drainage. In principle, NWSDB directly manages and operates the water supply facilities implemented by itself from operation and maintenance to billing and collection. For this purpose, the country is divided into eleven areas to which Additional General Managers and Deputy General Managers are deployed for management.

A rural area for this purpose is defined as any Grama Niladaree (GN) Division within a Pradeshiya Sabha (PS) area. The Provincial Councils are responsible for the implementation of small-scale rural water supply through local authorities (municipal councils, urban councils, pradeshiya sabhas). The roles of the Government, Provincial Council and the Local Government Authorities should be to regulate and facilitate in the implementation of the sector activities while the Community Based Organization (CBOs), Private Sector and NGOs should be the providers of services. Local Authorities also may provide services when required. In the National Policy for Rural Water Supply and Sanitation Sector (July 2001) says that users should (1) be encouraged to own and manage the facilities and assets, (2) be encouraged to share the capital investment incurred in creating the facilities, and (3) bear the

full responsibility of sustainable operation and maintenance of the facilities.

As shown in **Table 1.4**, the target of population coverage by pipe borne water supply is 52.4% as a whole out of which 40.4% is undertaken by NWSDB for attainment and the remaining 12.0% is the target for rural water supply.

1.4 Financial Situations of the Sector

The financial aspects of the whole of NWSDB are reviewed.

According to the financial statements of NWSDB from 2003 to 2011, the profit/ loss table is shown in **Table 1.8**. The operating account balances show an operating profit in 2003, 2005, 2006, 2009 and 2011.

The tariff was increased in 2004 and in the following two years there was an operating profit mainly due to the increase in income from sales. However the tariff increase had a short term effect, because in the second year (2006) after the increase, profits decreased and after that there were operating losses in 2007 and 2008, with the loss in 2008 being much higher than the previous year. Therefore, the tariff was increased in 2008, which resulted in an operating profit in 2009, followed by a large operating loss in 2010.

In 2011, an operating profit was achieved and it is understood that NWSDB made efforts to cut costs. This year is unusual from the aspect of the current account balance, because non-operating account losses were much more than operating profits and so the current account balance which was negative from 2003 to 2010, became positive in 2011 for the first time during the past nine years.

However, it is not possible to comments on whether current account profits will continue in the future, as the tariff is controlled by the government at a low level and increases in the tariff are generally delayed and do not keep up with inflation. In addition, the finance cost in 2011 was less than in 2009 and 2010, by approximately 0.5 billion Rs in each year. If the finance cost in 2011 was at the level of the cost in 2009 or 2010, the non-operating loss would be 1.78 billion Rs., which is more than the operating profit (1.76 billion Rs.) and as such the current account balance would be negative (This is discussed again later in balance sheet analysis).

Among the direct operating costs (expenses), personnel costs are the biggest in most years, accounting for 44.8% in 2011. The second biggest operating cost in 2011 was administration overheads with a share of 32.8%. The above two costs account for more than 75% of direct operating costs. However, the average annual increase in repair and maintenance costs was

higher than for all other direct operating costs (18.0%) from 2003 to 2011. The second highest was that of rents, rates, taxes, etc. (17.3%). Operating costs for pumping and depreciation showed lower average annual increase rates (9.1% and 9.2%, respectively), excluding that of other operating costs that fluctuate.

NWSDB's balance sheet from 2003 to 2011 is shown in **Table 1.11**. The first table shows "assets." The "capital work in progress" in the non-current assets is more than "property, plant & equipment" in every year and increases every year. This means that construction and rehabilitation work is always more than fixed assets.

The second table shows "equity and liabilities." In "capital and reserves," "government grant" and "capital grants" are very high in the past nine years accounting for 85% of "total equity and liabilities" in 2011. In addition, "capital grants" (mostly foreign grants) were less than the "government grant" from 2003 to 2005, but since then they have been more than the "government grant" in every year except for 2007. It is also noticeable that the "accumulated loss" increased each year and this is covered by grants and liabilities. It is strange that the "accumulated loss" increased in 2011 although the current account balance was positive in this year. However, it has been ascertained that the "accumulated loss" increased because of prior year adjustments, such as salary arrears and Ministry advance write-off. In the "non-current liabilities," the "loan payable" is less than grants, but it increased every year. Furthermore, the "loan interest payable" has been increasing in recent years, in particular from 2008. This corresponds to the discussion about the finance costs in the profit/ loss above. This means more loan interest payments were delayed recently and the current account balance seems red substantially in 2011.

Consequently, the financial situations of NWSDB do not seem sound. NWSDB has a lot of loans and so has to pay the loan interest and repay the loans. However, it can make neither operating profits nor current balance profits easily. In order to improve the situation, it is necessary to increase revenues and cut expenses. However, the income relates closely to the tariff which is controlled by the government, so it is not easy to increase revenues. It seems that if NWSDB lacks money, the government may give grants. Therefore, NWSDB cannot be considered a financially independent sustainable entity.

Table 1.8 Profit/ Loss of NWSDB

| Item | Year | 2003 | 2004 | 2005 | 2006 | 2007 | 2008 | 2009 | 2010 | 2011 |
|----------------------------------|------|---------------|---------------|---------------|---------------|----------------|----------------|----------------|----------------|----------------|
| Sales of water | | 4,135,900,339 | 4,263,830,351 | 5,446,263,579 | 5,869,448,092 | 6,481,915,574 | 6,743,217,327 | 9,669,975,867 | 10,744,059,534 | 11,616,045,254 |
| Other operating income | | 727,867,450 | 645,046,477 | 814,457,513 | 1,074,822,450 | 1,129,364,580 | 1,391,118,020 | 1,397,317,115 | 1,566,297,797 | 2,081,716,017 |
| Operating Income | | 4,863,767,789 | 4,908,876,828 | 6,260,721,092 | 6,944,270,542 | 7,611,280,154 | 8,134,335,347 | 11,067,292,982 | 12,310,357,331 | 13,697,761,271 |
| Direct operating expenses | | 2,834,131,407 | 3,454,131,782 | 3,604,024,192 | 4,080,524,657 | 4,902,547,316 | 6,088,841,694 | 6,321,949,712 | 7,061,727,544 | 7,470,490,082 |
| Personnel cost | | 1,068,274,105 | 1,408,733,213 | 1,599,810,859 | 1,829,346,805 | 2,335,091,573 | 2,633,355,899 | 2,830,486,142 | 3,346,857,362 | 3,345,000,435 |
| Pumping cost | | 1,207,036,638 | 1,248,338,029 | 1,217,702,035 | 1,360,669,505 | 1,587,873,327 | 2,104,778,364 | 2,025,805,684 | 2,103,576,701 | 2,417,486,303 |
| Chemical cost | | 193,376,960 | 286,914,658 | 301,387,232 | 319,570,787 | 349,492,607 | 436,027,228 | 421,702,108 | 412,935,647 | 426,959,662 |
| Repairs & maintenance | | 155,126,555 | 238,275,589 | 221,268,901 | 256,858,175 | 287,034,821 | 454,778,478 | 485,572,435 | 560,276,883 | 581,807,386 |
| Establishment expenses | | 91,162,859 | 106,428,937 | 122,737,408 | 137,637,825 | 152,013,097 | 213,069,370 | 229,811,749 | 248,970,965 | 272,493,532 |
| Rent, rates, taxes, etc. | | 119,154,290 | 165,443,357 | 141,117,757 | 176,441,560 | 191,041,890 | 246,832,355 | 328,571,593 | 389,084,987 | 426,742,765 |
| Administration overheads | | 784,536,152 | 962,238,646 | 999,273,784 | 1,348,603,525 | 1,762,775,528 | 1,895,309,365 | 2,062,268,144 | 2,564,857,342 | 2,447,412,103 |
| Depreciation | | 966,206,589 | 752,748,842 | 1,043,413,735 | 1,100,006,942 | 1,381,373,713 | 1,397,510,699 | 1,409,852,073 | 3,258,762,679 | 1,769,054,208 |
| Other operating expenses | | | 123,242,899 | 177,410,662 | 159,864,181 | 139,810,303 | 468,138,615 | 1,089,308,312 | 3,953,088,317 | 249,979,834 |
| Operating Expenditure | | 4,584,874,148 | 5,292,362,169 | 5,824,122,373 | 6,688,999,305 | 8,186,506,860 | 9,849,800,373 | 10,883,378,241 | 16,838,435,882 | 11,936,936,227 |
| Operating Profit/ Loss | | 278,893,641 | -383,485,341 | 436,598,719 | 255,271,237 | -575,226,706 | -1,715,465,026 | 183,914,741 | -4,528,078,551 | 1,760,825,044 |
| Non-operating income | | 136,474,325 | 96,556,001 | 32,633,847 | 114,477,942 | 203,386,141 | 59,918,167 | 48,782,302 | 97,644,018 | 131,257,102 |
| Finance cost | | 613,048,615 | 647,054,533 | 663,370,716 | 511,983,308 | 851,942,058 | 1,192,769,345 | 1,568,941,934 | 1,419,459,214 | 943,355,146 |
| Tsunami cost/Revaluation deficit | | 0 | 0 | 0 | 7,981,932 | 0 | 0 | 0 | 0 | 474,261,491 |
| Non-operating Profit/ Loss | | -476,574,290 | -550,498,532 | -630,736,869 | -405,487,298 | -648,555,917 | -1,132,851,178 | -1,520,159,632 | -1,321,815,196 | -1,286,359,535 |
| Current-account payment balance | | -197,680,649 | -933,983,873 | -194,138,150 | -150,216,061 | -1,223,782,623 | -2,848,316,204 | -1,336,244,891 | -5,849,893,747 | 474,465,509 |

Source: NWSDB

Table 1.9(1) Assets in Balance Sheet of NWSDB

(Unit: Million Rs.)

| Item | Year | 2003 | 2004 | 2005 | 2006 | 2007 | 2008 | 2009 | 2010 | 2011 |
|-----------------------------|------|--------|--------|--------|---------|---------|---------|---------|---------|---------|
| Non-current Assets | | | | | | | | | | |
| Property, Plant & Equipment | | 54,864 | 66,462 | 77,358 | 89,991 | 100,813 | 115,632 | 135,978 | 149,210 | 178,292 |
| Capital Work in Progress | | 24,649 | 25,419 | 36,767 | 42,182 | 52,406 | 55,197 | 63,086 | 73,666 | 84,271 |
| Intangible Assets | | 29,460 | 40,402 | 40,448 | 47,681 | 48,291 | 60,344 | 72,815 | 75,479 | 93,974 |
| Investments | | 96 | 96 | 0 | 0 | 0 | 0 | 0 | 0 | 0 |
| | | 660 | 545 | 144 | 129 | 115 | 91 | 77 | 65 | 47 |
| Current Assets | | | | | | | | | | |
| Non-operating Assets | | 9,503 | 9,533 | 11,852 | 13,620 | 13,094 | 15,190 | 13,460 | 14,984 | 14,479 |
| Inventories | | 0 | 0 | 192 | 191 | 191 | 191 | 159 | 187 | 130 |
| Trade & Other Receivables | | 2,113 | 1,891 | 2,151 | 2,283 | 2,602 | 3,081 | 3,306 | 3,283 | 3,553 |
| Deposits & Advances | | 3,209 | 3,872 | 4,994 | 5,079 | 6,021 | 5,250 | 4,301 | 4,164 | 4,631 |
| Investments | | 3,104 | 2,771 | 3,171 | 4,209 | 2,945 | 5,422 | 4,766 | 5,578 | 4,463 |
| Cash & Cash Equivalents | | 762 | 969 | 673 | 1,650 | 850 | 423 | 304 | 612 | 987 |
| | | 315 | 29 | 672 | 207 | 484 | 823 | 625 | 1,161 | 715 |
| Total Assets | | 64,368 | 75,995 | 89,210 | 103,611 | 113,907 | 130,822 | 149,438 | 164,194 | 192,772 |

Source: NWSDB

Table 1.9(2) Equity and Liabilities in Balance Sheet of NWSDB

(Unit: Million Rs.)

| Item | Year | 2003 | 2004 | 2005 | 2006 | 2007 | 2008 | 2009 | 2010 | 2011 |
|-----------------------------------|------|--------|--------|--------|---------|---------|---------|---------|---------|---------|
| Capital and Reserves | | 50,469 | 60,544 | 71,964 | 84,174 | 92,797 | 105,226 | 118,734 | 128,381 | 150,712 |
| Assets taken over from Government | | 185 | 185 | 185 | 185 | 185 | 185 | 185 | 185 | 185 |
| Equity Capital/ Government Grant | | 27,730 | 31,545 | 36,693 | 42,361 | 48,851 | 54,560 | 58,446 | 62,618 | 69,440 |
| Capital Grants | | 22,878 | 29,976 | 36,339 | 43,096 | 46,507 | 56,142 | 67,190 | 78,620 | 94,203 |
| Capital Recovery Fund | | 742 | 881 | 1,060 | 1,261 | 1,487 | 1,819 | 2,151 | 2,532 | 3,041 |
| Staff Welfare Fund | | 10 | 10 | 12 | 12 | 12 | 15 | 13 | 13 | 14 |
| Revaluation Reserve | | 310 | 310 | 310 | 310 | 310 | 310 | 310 | 0 | 0 |
| Accumulated Profit/ Loss | | -1,388 | -2,363 | -2,635 | -3,051 | -4,555 | -7,804 | -9,560 | -15,588 | -16,172 |
| Non-current Liabilities | | 12,113 | 13,310 | 14,948 | 17,301 | 18,257 | 20,281 | 23,324 | 26,475 | 31,474 |
| Loan Payable | | 10,816 | 11,913 | 13,466 | 15,697 | 16,526 | 18,113 | 20,137 | 23,071 | 27,839 |
| Other Deferred Liabilities | | 1,297 | 1,397 | 1,482 | 1,604 | 1,731 | 2,167 | 3,188 | 3,405 | 3,635 |
| Current Liabilities | | 1,787 | 2,141 | 2,298 | 2,136 | 2,852 | 5,315 | 7,379 | 9,338 | 10,586 |
| Creditors | | 1,147 | 1,170 | 1,203 | 1,081 | 1,210 | 1,347 | 2,173 | 2,345 | 3,489 |
| Loan Capital Payable | | 0 | 0 | 573 | 295 | 699 | 1,411 | 2,256 | 2,362 | 2,688 |
| Loan Interest Payable | | 289 | 230 | 91 | 142 | 284 | 1,457 | 1,896 | 3,157 | 2,465 |
| Non-operating Liabilities | | 0 | 0 | 115 | 115 | 115 | 115 | 115 | 161 | 133 |
| Other Payables | | 351 | 740 | 317 | 502 | 544 | 985 | 939 | 1,312 | 1,811 |
| Total Equity and Liabilities | | 64,368 | 75,995 | 89,210 | 103,611 | 113,907 | 130,822 | 149,438 | 164,194 | 192,772 |

Source: NWSDB

1.5 Activities and Policies of International Development Partners and National Agencies of the Sector

After the conflict termination in April 2009, a variety of countries offer a helping hand to the assistance for Sri Lanka. According to “Performance Report 2011” published by the Ministry of Water Supply and Drainage, there are thirty foreign-funded water supply and sewerage projects in which twelve countries and four international agencies are involved. They are categorized on the sector basis as shown in **Table 1.10**.

Table 1.10 Bi- and Multi-lateral Assistance to Sectors in Sri Lanka

| | Water Supply | | | Sewerage |
|--|---|----------|---|-------------------------------------|
| | Urban | Rural | Others | |
| Bilateral and Multi-lateral Assistance | Japan (JICA) Denmark (DANIDA) Hungary Spain Netherland Germany (KfW) Korea Austria Australia France Belgium | ADB | ADB UNICEF WB IFRC (Red Cross) | Japan Australia Sweden (SIDA) |
| | 11 countries | 1 agency | 4 agencies | 3 countries |

Major donors during the year 2011 are ADB, JICA (Japan), KfW (Germany), SIDA (Sweden) , UNICEF, IFRC (International Federation of Red Cross and Red Crescent Societies), Austria, France, Spain, Hungary, Korea and Netherland. As shown in **Table 1.10**, JICA provides assistance to both water supply and sewerage sectors, although focusing on urban water supply. On the contrary, ADB has concentrated into rural water supply and provided 6th assistance following 3rd and 4th assistance. JICA assistance includes not only the hard components represented by the construction of facilities but also the soft components like capacity building. KfW supports the energy saving project at Ambatale

ADB and IFRC were concerned with Tsunami-related assistance, while UNICEF is addressing to water, sanitation and hygiene programme and WB to the increase of number of sewerage connections and access to safe sanitation focusing on the poor.

CHAPTER 2 NATURAL AND SOCIAL CONDITION

2.1 General

Anuradhapura is located about 280 km north-northeast of Colombo, and about 140 km north-northwest of Kandy and is an inland district in the North Central Province. The district is classified as a dry zone climatologically with less rainfall and has about 2,500 small tanks for irrigational use. The district capital of Anuradhapura and its surrounding area was the first capital of the Ancient Sunghalese Dynasty that flourished from the 3rd century BC to the 9th century AD and is registered as the world's cultural heritage.

The study area consisting of six Divisional Secretariat Divisions (DSDs), namely Padaviya, Kebithigollewa, Horowpothana, Kahatagasdigilia, Medawachchiya and Rambewa is located in the northeast part of Anuradhapura District as shown in **Figure 2.1** and is bounded by Trincomalee District to the east and by Vavuniya District to the north. It has a total area of 286,268 ha, a total population of 175,890 persons (2001 Census) and is a typical rural area.

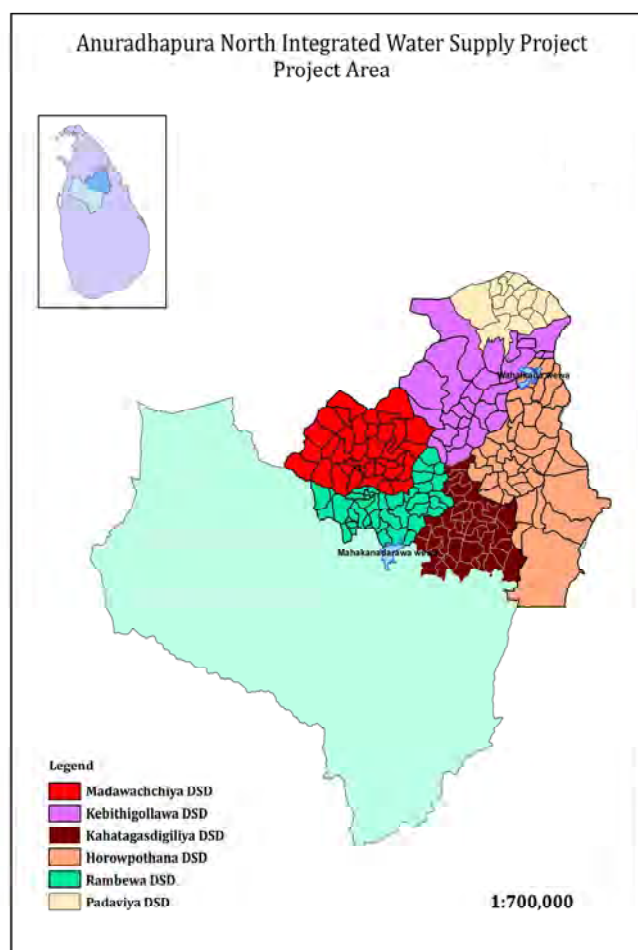

Figure 2.1 Location of Study Area

2.2 Natural Conditions

2.2.1 Topography

The study area extends over three river basins, namely, (1) Malwathu Oya, (2) Ma Oya and (3) Yan Oya. The watershed between the Ma Oya and Yan Oya runs one to two km west of national road B211, while that between the Malwathu Oya and the Ma Oya and Yan Oya runs almost in the centre between national road A9 and B538.

The western terrain of the Malwathu Oya watershed generally slopes downwards in a northwesterly direction, while the eastern terrain slopes downwards in a southeasterly direction with undulations.

2.2.2 Geology

The geology of the major part of the study area is highly crystalline, formed by metamorphosis of well bedded sediments in an old geosyncline. Within the study area there are five rock types which are generally in the Central and Eastern parts of the district of the Highland series. Mica mines in Kebithigollewa and limestone deposits in Palagala to Horowpathana are the major mineral resources in the study area.

In the North Central region, the so-called "hard rock" or crystalline basement complex of rocks are well known for their very limited quantities of shallow groundwater. It is now recognized that this shallow groundwater benefits from the presence of several small tank cascades systems that are distributed across this landscape. This has enabled the recent development of agrowell farming, especially in the Anuradhapura district where it is reported that around 15,000 agrowells are in operation; and almost all of these are situated in the lower aspects of the shallow inland valleys which receive some degree of seepage from the small village tanks that are located upstream.¹ (Refer to **Section 4.3.1** (2) for more details).

Fluoride, derived from fluorite (the principal fluoride mineral in igneous rocks) and the minerals apatite and mica, is generally present in only low concentration in groundwater. Volcanic or fumarolic gases may contain fluoride, and in some areas these may be the source of fluoride in groundwater.²

¹ C. R. Panabokke, "Nature of occurrence and sustainable use of groundwater resources for agriculture in the North central, north western and North eastern regions of Sri Lanka", *Tropical Agriculture Research and Extension*, July 2003

² Fletcher G. Driscoll, "Groundwater and Wells – Second Edition", *Johnson Filtration Systems Inc.*, 1989

2.2.3 Climate

(1) Temperature

The climatological pattern is classified into two seasons for cultivation purposes in Sri Lanka as follows:

- Maha season from October to March called as the wet season
- Yala season from April to September called as the dry season

During the dry season from April to September, the monthly average temperature is very stable in the range of 29°C to 30°C. However at the start of the wet season from October, the temperature decreases with the coldest months being December and January at about 26 °C, following which the temperature increases.

(2) Rainfall

The annual average rainfall in the period from 1961 to 1990 in Anuradhapura District was 1,285 mm, but more than two-thirds of the annual rainfall occurs in the Maha season. In addition, as more than 70% of the rainfall during this period is concentrated in the period from October to December, there is a large monthly fluctuation in rainfall.

(3) Relative Humidity

Relative humidity is stable during the period from February to September, then begins to increase with a peak of between 79% and 84% in December, following which it decreases.

2.3 Social Conditions

2.3.1 Population

Population, population density and population growth rate of Sri Lanka, Anuradhapura District and study area is summarised in **Table 2.1**.

Table 2.1 Population, Population density and Growth Rate of Sri Lanka, Anuradhapura

| | Area (km ²) | Population ('1,000) | | | Population Density (persons/km ²) | | Annual Average Growth Rate (%) | |
|---------------------|-------------------------|---------------------|-----------------|-----------------|---|------------|--------------------------------|-------------|
| | | 1981 | 2001 | 2012 | 2001 | 2012 | 2001/1981 | 2012/2001 |
| Sri Lanka | 66,510 | 14,846.8 | 18,797.3 | 20,277.6 | 300 | 323 | 1.16 | 0.71 |
| Urban | | 3,192.7 | - | - | | | - | - |
| Rural | | 11,654.3 | - | - | | | - | - |
| Anuradhapura | 7,179 | 587.9 | 745.7 | 855.6 | 112 | 128 | 1.25 | 1.33 |
| (% to Sri Lanka) | | (4.0%) | (4.0%) | (4.2%) | | | | |
| Urban | | 41.4 | 53.2 | - | | | 1.26 | - |
| Rural | | 546.5 | 692.5 | - | | | 1.19 | - |
| Study Area | 2,843 | | 175,890 | 205,171 | 62 | 72 | | 1.41 |

| | Area (km ²) | Population ('1,000) | | | Population Density (persons/km ²) | | Annual Average Growth Rate (%) | |
|-------------------|-------------------------|---------------------|--------|--------|---|------|--------------------------------|-----------|
| | | 1981 | 2001 | 2012 | 2001 | 2012 | 2001/1981 | 2012/2001 |
| Padaviya | 240 | | 21,146 | 22,924 | 88 | 96 | | 0.74 |
| Kebithigollewa | 615 | | 19,457 | 22,227 | 32 | 36 | | 1.22 |
| Horowpothana | 845 | | 29,642 | 36,714 | 35 | 43 | | 1.96 |
| Kahatagasdigiliya | 352 | | 33,572 | 40,137 | 95 | 114 | | 1.64 |
| Medawachchiya | 482 | | 40,469 | 46,743 | 84 | 97 | | 1.32 |
| Rambewa | 309 | | 31,604 | 36,426 | 102 | 118 | | 1.30 |

- The total population of Sri Lanka in the Census 2011 was 20,277,600 persons and the annual average population growth rate was significantly declined from previous 1.16% (1981-2001) to 0.71% (2001-2012).
- The total population of Anuradhapura District in the above census was 745,693 persons, composed of an urban population of 53,151 (7.1%), a rural population of 691,573 (92.7%) and an estate population of 969 (0.1%).
- In Anuradhapura District, Anuradhapura and its surrounding area is categorised as an urban area with a population of 53,151 persons and all of the remaining is categorized as a rural area. Therefore, the entire study area is considered as a rural area.
- The average population density of Anuradhapura District was 104.0 persons/km² in the 2001 Census, with the density in the study area being lower than in other DSDs, especially in Kebithigollewa (31.7 persons/km²) and Horowapothana (35.8 persons/km²), respectively. For reference, the average population density of the study area was 62.3 persons/km² in the Census 2001.
- The total national population in the Census 2011 is 20,277,597 persons with an annual average growth rate of 0.71% in the period from 2001 to 2012, which is lower than 1.16% in the period from 1981 to 2001.
- Similarly, the population in the Anuradhapura district in the Census 2011 is 855,562 persons with an annual average growth rate of 1.33% in the period from 2001 to 2012, which is the highest out of the 18 districts covered in the Census 2011 and a small increase from the growth rate of 1.25% in the period from 1981 to 2001.

2.3.2 Land Use

Anuradhapura is the largest of all districts in Sri Lanka, covering an area of 738,953 ha which is 11% of the whole country's land surface. The land use includes large areas of paddy fields, scrublands, forested areas, mixed cultivations, Chena cultivations, home gardens and residences. The majority of the people in the area are farmers and largely depend on paddy cultivation. Apart from that the district economy is predominantly centred on chena and home gardens with vegetable cultivation. Additionally animal husbandry including cattle, goat and poultry is also common in some locations.

2.3.3 Income and Expenditure

(1) Income

The average monthly household income in the Household Income and Expenditure Survey 2009/2010 was Rs.36,451 as a whole, Rs.47,783 in urban areas and Rs.35,228 in rural areas at the national level, and Rs.37,586 in Anuradhapura District, which was ranked in 5th position behind Colombo (Rs.51,070), Gampala (Rs.48,870), Ratnapura (Rs.41,312) and Vanuviya (Rs.39,640).

(2) Expenditure

The average monthly household expenditure was Rs.31,331 as a whole, Rs.44,928 in urban areas and Rs.29,423 in rural areas, which is 65.5% or about two-thirds of that of the urban area at the national level, and Rs.29,065 in Anuradhapura District, which was ranked in 9th position behind Colombo (Rs.47,291), Gampala (Rs.41,062), Kalutara (Rs.35,549) and so on.

(3) Percentage of Water Rate to Disposal Income in the Household Income and Expenditure

The monthly water and electricity bills³ are Rs.99.75 and Rs.531.64 per household on national average, respectively, of which percentages to the total household income are 0.27% and 1.45%. The World Bank⁴ estimates the limit for household affordability to pay for water supply services as 4% of household income. The Pan American Health Organization⁵ also recommends that the total water supply and sewerage charge should be less than 5% of the household income, consisting of 3.5% for water supply and 1.5% for sewerage. The present water charge in Sri Lanka at 0.27% of household income is around one-twelfth of the ceiling (3.5%) set by an International organization.

According to “Household Income and Expenditure Survey – 2009/10” (hereinafter referred to as “HIES 2009/10”), the HI (Poverty Head Count Index, the percentage of population below Poverty Line) in Anuradhapura District is 5.7%, ranked at the 4th following Vavuniya (2.3%), Colombo (3.6%) and Gampaha (3.9%) and categorised into a relatively rich province group. However, the five DSDs out of six DSDs in the study area have the higher HI values than the district average with 28.2% of the poor population

The poverty line is to capture the basic needs necessary to meet minimum living standard defining the consumption bundle which include food and non-food items, and raises as the individual component price increases. The poverty line was Rs.2,142 at national level and Rs.2,099 in

³ Source: Department of Census and Statistics, “Household Income and Expenditure Survey -2009/10”, August 2011

⁴ “Information and Modeling Issues in Designing Water and Sanitation Subsidy Scheme”, The World Bank, May 2000

⁵ “Methodology of Economic Evaluation in Development Study – 9. Water Supply -”, JICA, march 2002 (Japanese)

Anuradhapura District in the year of 2012, which increased to Rs.3,579 and Rs.3,508, respective in November 2012, but those corresponding to 2009/10 were not available.

Table 2.2 Basic Data

| Year of Data | Item | Whole | | Urban | | Rural | |
|--------------|------------------------------------|---------------|----------------|--------------|----------------|--------------|----------------|
| | | Income (Rs.) | Percentage (%) | Income (Rs.) | Percentage (%) | Income (Rs.) | Percentage (%) |
| 2009/10 | 1 st Decile Average | 5,723 | | | | | |
| 2009/10 | 1 st Decile Median | 6,080 | 5.0 | | | | |
| 2009/10 | Poverty Line (Anuradhapura Dist.) | N/A | 8.9 (5.7) | N/A | 5.3 | N/A | 9.4 |
| 2012-Nov. | Poverty Line (Anuradhapura Dist.) | 3,579 (3,508) | | | | | |
| 2009/10 | 1 st Decile Upper Limit | 8,627 | 10.0 | 12,000 | 10 | 8,333 | 10 |

Note: As the HI value of Anuradhapura District in 2009/10 was 8.9%, it should be placed between the median (5%) and the upper limit (10%) of the income 1st decile, but the poverty line for November 2012 is Rs. 3,508 which is below a 1st decile median of Rs.6,080 with a discrepancy, although the poverty line for 2009/10 is not available.

The data for urban, rural, Anuradhapura District is not available, therefore the data for the whole or the country is used for the following study:

Since the HI value for the country 8.9% for 2009/10, all the poor can be considered to belong to the 1st decile or 10% from the lowest. On the assumption of a population of 4 persons/ household and an average water consumption of 11 m³/month (= 4 persons × 91 Lpcd × 30.4 days/month), the water rate (Rs.168) is 2.8% to the 1st income decile median of Rs.6,080 in case of applying the special tariff (Domestic - Samurdhi Receipts), which is within 4% of the disposal income recommended by the World Bank. Even applying the normal tariff (Domestic – Non Samurdhi Tenement Garden) to the customer exceeding the 1st income decile median, the water rate is in the range of 2.8% to 2.6% to the disposal income which is in the level of no problem. This result suggests that there are households with an income of below Rs.4,200 (= Rs.168 / 0.04) that the water rate exceeds 4% of the disposal income. The percentage of the number of such households is estimated at about 3.5% (= 5% × Rs.4,200 / Rs.6,080) to the total district household number and about 0.8% (= 3.5% × 0.236) to the study area household number using the population percentage of study area to the whole district

2.4 Economic Conditions

According to the employment population by industry in Sri Lanka, the population engaged in agriculture decreased from 46.8% in 1990 to 32.6% in 2001 (or a 14.2 percentage points decrease), while the population engaged in industry increased from 13.3% to 17.0% (or a 3.7 percentage points increase). In the same period employment in trade and hotels increased from 9.6% to 13.0% (or a 3.4 percentage points increase) and in services from 15.7% to 18.5% (or a

2.8 percentage points increase). The transition from an agriculture-dependent economy has been steadily progressing.

2.4.1 Agriculture

The main industry of Anuradhapura District is agriculture but it does not produce significant quantities of the three major export products of the country, namely rubber, tea and coconut, accounting for only 3.6 % of the national total, with the major agricultural product being rice.

For the rice harvest from the paddy field, Anuradhapura District is ranked 4th in the country with a national share of 8.8% to 10.8% and it can be said that Anuradhapura District is one of the major rice-producing districts in Sri Lanka. However, the yearly fluctuation of the rice harvest is heavily dependent on to what extent the irrigational water requirement is met during the drought period. Historical data shows that a long-term drought occurred during the period from 1987 to 1993.

Apart from rice, the province's other products include sesame, millet, chilies, peanuts, fruit, vegetables and dairy produce.

2.4.2 Industry

The industrial output product of Anuradhapura District in 2008 was Rs.12,036 billion, which is equivalent to 0.7% of the national industrial product of Rs.1,618,344 million. In the meaning of industrialization, Anuradhapura District is obviously lagging behind other parts of the country.

2.4.3 Tourism

Tourism areas in Sri Lanka are classified into seven resort regions and Anuradhapura District belongs to the group of “Ancient Cities” together with Kandy, Polonnaruwa and Kurunegala, focusing on the ancient Buddhism relics.

For the accommodation capacity (rooms) in Graded Establishment, Ancient Cities have kept a share of about 20% during the period from 2001 to 2010, but for the occupancy rates, there has been a drastic change. From 2001 to 2004, occupancy increased from 39.1% to 60.4%, but in 2005, there was a drastic drop to 39.5% and since that it has hovered at a low level of about 40%. In 2010 there was a significant improvement to 62.6%, or 18.2 percentage points up from the previous year of 44.4%, due to the end of conflict.

2.5 Necessity of the Project

2.5.1 Principal Drinking Water Source

(1) Principal Drinking Water Source

According to Census 2001 (**Table 2.3**), the drinking water sources are composed of groundwater (92.7%) from dug wells (80.2%) and tube wells (12.5%), and tap water (4.1%). The rural water supply was not reported at this point.

Table 2.3 Principal Source of Drinking Water in the Study Area (2001 & 2011)

| Drinking Water Source (2001) | | | | | | | | | | | | | |
|------------------------------|---------------|--------------------------------|---------------------------------|------------------|--------------|-----------------|--------------------------------------|----------------------|----------------------------|--------|---------------|--|--------------|
| | No. of HHs | Well | | | Tube Well | Pipe Born Water | | | Rural Water Supply Project | Other | | | Not Reported |
| | | Protected Well within Premises | Protected Well outside Premises | Unprotected Well | | Tap within Unit | Tap within Premises but outside Unit | Tap outside Premises | | Bowser | Bottled Water | River / Tank / Stream / Spring and Other | |
| | (HHs.) | (HHs) | (HHs) | (HHs) | (HHs) | (HHs) | (HHs) | (HHs) | (HHs) | (HHs) | (HHs) | (HHs) | |
| Anuradhapura District | 189,699 | 41,482 | 71,316 | 25,931 | 26,630 | | 12,279 | 5,858 | | | | 3,538 | 2,665 |
| | | | 138,729 | | 26,630 | | 18,137 | | - | | | 3,538 | 2,665 |
| Wahalkada Area | | | | | | | | | | | | | |
| Padaviya | 5,452 | 1,039 | 1,176 | 2,037 | 520 | | 253 | 161 | | | | 216 | 50 |
| Kebithigollewa | 4,903 | 932 | 1,845 | 1,086 | 560 | | 139 | 87 | | | | 151 | 103 |
| Horowpothana | 7,578 | 1,913 | 3,332 | 887 | 1,079 | | 49 | 68 | | | | 158 | 92 |
| Kahatagasdigiliya | 8,619 | 2,141 | 4,201 | 677 | 814 | | 480 | 158 | | | | 61 | 87 |
| Sub-total | 26,552 | 6,025 | 10,554 | 4,687 | 2,973 | | 921 | 474 | | | | 586 | 332 |
| | | | 21,266 | | 2,973 | | 1,395 | | - | | | 586 | 332 |
| Mahakanadarawa Area | | | | | | | | | | | | | |
| Medawachchiya | 10,338 | 2,974 | 3,627 | 1,387 | 1,654 | | 193 | 216 | | | | 68 | 219 |
| Rambewa | 8,230 | 2,179 | 3,867 | 905 | 1,007 | | 11 | 16 | | | | 173 | 72 |
| Sub-total | 18,568 | 5,153 | 7,494 | 2,292 | 2,661 | | 204 | 232 | | | | 241 | 291 |
| | | | 14,939 | | 2,661 | | 436 | | - | | | 241 | 291 |
| Total | 45,120 | 11,178 | 18,048 | 6,979 | 5,634 | | 1,125 | 706 | | | | 827 | 623 |
| | | | 36,205 | | 5,634 | | 1,831 | | - | | | 827 | 623 |

Source: "Census 2001", Department of Census and Statistics

| Drinking Water Source (2011) | | | | | | | | | | | | | |
|------------------------------|---------------|--------------------------------|---------------------------------|------------------|--------------|-----------------|--------------------------------------|----------------------|----------------------------|-----------|---------------|--|--------------|
| | No. of HHs | Well | | | Tube Well | Pipe Born Water | | | Rural Water Supply Project | Other | | | Not Reported |
| | | Protected Well within Premises | Protected Well outside Premises | Unprotected Well | | Tap within Unit | Tap within Premises but outside Unit | Tap outside Premises | | Bowser | Bottled Water | River / Tank / Stream / Spring and Other | |
| | (HHs.) | (HHs) | (HHs) | (HHs) | (HHs) | (HHs) | (HHs) | (HHs) | (HHs) | (HHs) | (HHs) | (HHs) | |
| Anuradhapura District | 228,304 | 51,306 | 63,130 | 8,681 | 5,758 | 32,167 | 16,093 | 7,585 | 35,803 | 261 | 2,394 | 5,126 | |
| | | | 123,117 | | 5,758 | | 55,845 | | 35,803 | | | 7,781 | |
| Wahalkada Area | | | | | | | | | | | | | |
| Padaviya | 6,203 | 1,833 | 1,897 | 616 | 109 | 244 | 311 | 91 | 844 | 10 | 26 | 222 | |
| Kebithigollewa | 5,991 | 1,927 | 2,055 | 168 | 135 | 174 | 163 | 29 | 315 | | 4 | 1,021 | |
| Horowpothana | 9,352 | 3,988 | 4,449 | 212 | 144 | 32 | 30 | 6 | 295 | | 39 | 157 | |
| Kahatagasdigiliya | 10,386 | 3,355 | 4,404 | 179 | 114 | 463 | 340 | 73 | 1,236 | 1 | 126 | 95 | |
| Sub-total | 31,932 | 11,103 | 12,805 | 1,175 | 502 | 913 | 844 | 199 | 2,690 | 11 | 195 | 1,495 | |
| | | | 25,083 | | 502 | | 1,956 | | 2,690 | | | 1,701 | |
| Mahakanadarawa Area | | | | | | | | | | | | | |
| Medawachchiya | 12,560 | 3,420 | 4,350 | 407 | 780 | 652 | 583 | 215 | 1,210 | 14 | 336 | 593 | |
| Rambewa | 9,757 | 2,739 | 3,162 | 214 | 229 | 459 | 357 | 446 | 1,691 | | 58 | 402 | |
| Sub-total | 22,317 | 6,159 | 7,512 | 621 | 1,009 | 1,111 | 940 | 661 | 2,901 | 14 | 394 | 995 | |
| | | | 14,292 | | 1,009 | | 2,712 | | 2,901 | | | 1,403 | |
| Total | 54,249 | 17,262 | 20,317 | 1,796 | 1,511 | 2,024 | 1,784 | 860 | 5,591 | 25 | 589 | 2,490 | |
| | | | 39,375 | | 1,511 | | 4,668 | | 5,591 | | | 3,104 | |

Source: "Census 2011", Department of Census and Statistics

In Census 2011 (**Table 2.3**), 75.4% of the people in the study area relied on groundwater through dug wells (72.6%) and tube wells (2.8%), and tap water (18.9%), and the remaining 5.7% on others such as bowser, bottled water, river, etc. (Note: the population coverage by water supply in the study area is approximately 27% according to the existing CBO water supply schemes survey, some of them may not regard tap water as the main water source in spite of the

connection to a water supply schemes.) There are a decrease in the use of groundwater and an increase in the use of tap water. For the type of wells, unprotected dug wells and deep tube wells has substantially decreased and the protected dug wells have become popular. However, the water source of such small-scale water supply schemes are almost groundwater, there is no change in relying on groundwater.

(2) Water-fetching Distance to Water Source

Since the data on water-fetching distance in the study area is not available, that is described using the district-level data.

Table 2.4 Water-fetching Distance in Anuradhapura District

| Sector and District | Distance | | | | | | |
|---------------------|--------------|---------------------------|----------------------------|------------------|-----------------------|-----------------------|----------------|
| | Total (%) | Within premises (%) | Outside Premises (%) | Outside Premises | | | |
| | | | | ≤ 100 m (%) | 101 – 200 m (%) | 201 – 500 m (%) | > 500 m (%) |
| Sri Lanka | 100 | 76.3 | 23.7 | 16.0 | 3.3 | 3.1 | 1.3 |
| Urban | 100 | 88.9 | 11.1 | 8.9 | 0.7 | 0.9 | 0.6 |
| Rural | 100 | 75.0 | 25.0 | 16.4 | 3.7 | 3.5 | 1.4 |
| Estate | 100 | 62.0 | 38.0 | 31.1 | 3.7 | 3.1 | 0.1 |
| Anuradhapura | 100 | 58.0 | 42.0 | 18.3 | 7.8 | 9.5 | 6.4 |

Source: Department of Census and Statistics, "Household Income and Expenditure Survey -2009/10", August 2011

The distribution of drinking water sources in Sri Lanka is 76.3% within premises and 23.7% outside premises, while in Anuradhapura District, they are 58.0% and 42.0% respectively. It shows that the percentage of a drinking water source outside premises is rather high. The percentage of the number of households engaged in the water-fetching work is secondarily high following that in Jaffina District.

The distance allocation from a housing unit to a drinking water source is 16.0% for equal or less than 100 m, 3.3% for 101 – 200 m, 3.1% for 201 – 500 m and 1.3% for above 500 m (The national average for a rural area is 16.4%, 3.7%, 3.5% and 1.4%, respectively.), while in Anuradhapura District they are 18.3%, 7.8%, 9.5% and 6.4%, respectively, showing that the people in the district are forced the water-fetching work for a longer distance than a national average. As for the water-fetching distance, Anuradhapura District is ranked at the second for within 100 m, third for 101 to 200 m and second for above 500 m. On a national basis, the district is placed in a severe condition as well as Jaffina District.

In case of tap water, 43.4% of housing units have a tap indoors, 38.2% within premises and 18.4% outside premises. It means that one out of five housing units have no tap within premises.

(3) Per Capita Water Consumption at Existing CBOs

There are 50 existing water supply schemes maintained and operated by CBOs in the study area, of which the per capita water consumption is 66 Lpcd at 46 existing CBOs on average.

(4) Water Quality at Existing CBOs

Although there are 50 water supply schemes under CBOs in the study area out of which 45 CBOs have their water quality data of tap water. A fluoride concentration is above a desirable standard of 0.6 mg/L in 27 CBOs and above a permissible limit of 1.5 mg/L in 6 CBOs with the maximum value of 1.9 mg/L. The served population who are exposed to a risk of fluorosis by a fluoride concentration above a desirable limit counts 29,460 persons against 8,205 persons with no risk. The rate of populations with a risk versus with no risk is 78.2:21.8, that is to say, four out of five persons are exposed to a risk of fluorosis. Among them, a served population of 4,435 persons are exposed to a higher risk due to a fluoride concentration of above a permissible limit

Table 2.5 Water Quality of CBO's Supply System

| S/N | DSD | Water Source | Water Quality | | | | | | | |
|----------------------------------|---------------------------|--------------|-----------------|-------------|-----------------|-------------|--------------------|-----------------|---------|----------------------|
| | | | Hardness (mg/L) | Iron (mg/L) | Fluoride (mg/L) | Odor | Color (Hazen Unit) | Turbidity (NTU) | pH | Conductivity (µS/cm) |
| 1 | Swashakhi CBO | S | - | - | 0.85 | None | Clear | 0.05 | 7.86 | 860 |
| 2 | Ikra CBO | D-1, S-1 | - | - | 0.83 | None | Clear | 0.06 | 7.72 | 950 |
| 3 | Arunalu CBO | S | - | - | 0.59 | fishy | Clear | 0.1 | 7.93 | 940 |
| 4 | Samagi CBO | D | - | - | 1.01 | None | Clear | 0 | 7.76 | 930 |
| 5 | Ekamuthu CBO | S | - | - | 0.32 | None | Clear | 0.08 | 7.74 | 700 |
| | Ekamuthu CBO-Kakukaliyawa | S | - | - | 1.19 | - | Clear | 0.03 | 7.77 | 880 |
| 6 | Rangiri CBO | D | - | - | 0.88 | None | Clear | 0.03 | 7.79 | 1,080 |
| 7 | Nildiadahara CBO | S | 360/280 | - | 0.72 | - | Clear | 0.15 | 7.77 | 740 |
| 8 | Eksath CBO | S | 340 | - | 0.4/0.78 | - | | | | |
| 9 | Mahasen CBO | S | 80 | - | 0.39 | - | Clear | 0.08 | 7.6 | 730 |
| 10 | Dimuthu CBO | | 312 | - | 0.57 | - | Clear | 0.12 | 7.91 | 610 |
| 11 | Pragathi CBO | | 344 | - | 1.38 | - | Clear | 0.05 | 7.7 | 1,450 |
| 12 | Jayashakhi CBO | D | - | - | 1.9 | None | Clear | 0.06 | 7.76 | 1,570 |
| 13 | Samagi CBO | D | 332/270/330 | - | 1.08 | - | Clear | 0.07 | 7.8 | 1,000 |
| 14 | Samagi CBO | S | - | - | 0.5 | - | <5 | 0.02 | - | 590 |
| 15 | Ekamuthu CBO | D | - | - | 0.81 | - | <5 | 0.03 | - | 650 |
| 16 | Ran Arunalu CBO | D | 490/720/640 | 0.03/- | 1.55/1.1/0.36 | - | | | | |
| 17 | Isuru CBO | D | High | - | 0.98 | None | Clear | 0.05 | 7.84 | 1,060 |
| 18 | Randiya Dhahara CBO | | - | - | 1.15 | None | Clear | 0.09 | 7.76 | 840 |
| 19 | Nelum CBO | S | - | - | 1.11 | None | Clear | 0.05 | 7.86 | 970 |
| 20 | Diriyamatha CBO | | 250/261/284 | - | 0.83 | - | Clear | 0.1 | 7.75 | 700 |
| | Diriyamatha CBO | | | - | 0.69 | - | Clear | 0.12 | 7.79 | 870 |
| 21 | Gemunu CBO | | - | - | 0.75 | - | <5 | 0.21 | - | 950 |
| 22 | Sisila Diyadahara CBO | | - | - | 0.76 | None | Clear | 0.06 | 7.83 | 880 |
| 23 | Diriyamatha CBO | | 373/342 | - | 0.86 | None | Clear | 0.1 | 7.64 | 1,220 |
| 24 | Ridi Nadi | | | | 0.21 | None | Clear | 0.06 | 7.75 | 610 |
| 25 | Shakthi CBO | D | 324 | 3.3 | 0.1 | | | | | |
| 26 | Al-Naja | D | - | - | | | | | | |
| 27 | CBO not formed | | - | - | | | | | | |
| 28 | Parakum CBO | D | 108 | 0.14 | 1.04 | - | Clear | 0 | 7.76 | 740 |
| 29 | Suwasehana CBO | D | 1.13 | - | 1.13 | - | Clear | 0.07 | 7.76 | 740 |
| 30 | Suwasetha CBO | S | - | - | 0.96 | - | Clear | 0.04 | 7.63 | 740 |
| 31 | Vajira CBO | D | 262/204 | - | 1.5/1.54 | - | | | | |
| 32 | Pragathi CBO | D | - | - | 0.58 | None | Clear | 0.08 | 7.54 | 1,430 |
| 33 | Janasetha CBO | S | - | - | 1.37 | - | Clear | 0.01 | 7.85 | 670 |
| 34 | Sobasisila CBO | S | - | - | 0.67 | - | Clear | 0.02 | 7.64 | 810 |
| 35 | Randiya | S-2 | - | - | 0.31 | - | Clear | 0.14 | 7.76 | 760 |
| 36 | Nilmini | D | - | - | | | | | | |
| 37 | Senath CBO | | - | - | 1.9 | None | Clear | 0.02 | 7.75 | 1,240 |
| 38 | Eksath CBO | S | 296 | - | 1.62 | None | Clear | 0.02 | 7.78 | 860 |
| 39 | Praja Shakthi CBO | | - | - | 0.42 | None | Clear | 0.01 | 7.85 | 520 |
| 40 | Apsara | S | - | - | 1.35 | - | Clear | 0.14 | 7.69 | 1,380 |
| 41 | Pinibindu CBO | R | | | | | | | | |
| 42 | Sham Sham | | - | - | | | | | | |
| 43 | Ekamuthu CBO | Well-2 | 264 | - | 0.14 | - | Clear | 0.05 | 7.6 | 640 |
| 44 | Pradeepa | D | 448 | - | 0.82 | - | Clear | 0.01 | 7.8 | 1,150 |
| 45 | Upul CBO | D | 290 | - | 0.92 | - | Clear | 0 | 7.83 | 1,000 |
| 46 | Jalasavi | D | - | - | 1.58 | - | Clear | 0.02 | 7.74 | 1,330 |
| 47 | Tristar CBO | D | 300 | - | 0.001 | | | | | |
| 48 | Alhidra CBO | D | 300 | - | 0.04 | | | | | |
| 49 | Adhikwa CBO | D | 280 | - | 0.7 | | | | | |
| 50 | Hansajala CBO | S | 442 | - | 1.8 | | | | | |
| Sri Lanka Standard (Desirable) | | | 250 | 0.3 | 0.6 | | 5 | 2 | 7.0-8.5 | 750 |
| Sri Lanka Standard (Permissible) | | | 600 | 1 | 1.5 | Unobjection | 30 | 8 | 6.5-9.0 | 3,500 |

S: Shallow Well, D: Deep Well, R: Rain Water Tank

The figure after hyphon (-) shows the number of wells.

300

Above the desirable limit

300

Above the permissible limit

In addition, out of 21 CBOs with a water quality data of hardness, 18 CBOs have above a desirable limit of 250 mg/L. The high concentration of hardness as well as fluoride is a big characteristics of this area.

(5) Water Supply Hours at CBOs

NWSDB NC has 24 water supply schemes and almost performs 24-hour water supply, which is ranked as the top class in NWSDB RSCs.

While looking at the study area, out of 46 water supply schemes surveyed, water supply hours are reportedly significantly limited during a dry period at 20 water supply schemes. They are less than five hours at ten schemes, five to ten hours at six schemes and ten to fifteen hours at four schemes. In addition, two water supply schemes limit the maximum water supply hours at eight hours. The water supply hours in the worst cases are two hours in Ekamuthu and three hours in Dimuthu, Samagi and Suwasetha.

Therefore, the people in the study area is forced the poor water supply conditions in comparison with other service area in NWSDB NC enjoying the 24-hour water supply.

(6) Technical Problems at Existing CBOs

The existing CBO water supply systems have the following technical problems in structure, designing and operation.

- No master valves at water tanks and/or tube-well pumps are installed.
- Leakage from tanks and/or pipeline
- No operational valves (air valve, gate valve and wash-out valves, etc.) are installed.
- Insufficient pressure due to under-sized pipes
- No proper chlorination dosage.
- Unstable electricity supply (power cut/voltage variation)
- Invisible customer meters
- Malfunction of tube-well pump
- Little water in dry season

2.5.2 Dental Fluorosis

(1) Distribution of fluoride concentration of groundwater in Sri Lanka

Fluoride is present particularly in rocks, soils and water in Sri Lanka. Fluoride occurs naturally in water due to weathering of rocks that contain fluoride rich minerals such as hornblende; $NaCa_2(Mg,Fe,Al)_5(Si,Al)_8O_{22}(OH,F)_2$, biotite; $K(Mg,Fe)_3(AlSi_3O_{10})(OH,F)_2$, apatite; $Ca_5(PO_4)_3(F,Cl,OH)$ and fluorite; $CaTiSi(O,F)_5$. In 1987, a nationwide field survey was carried out and fluoride in groundwater was revealed. From the survey results, the two major types of groundwater, Ca-Cl type and Ca-HCO₃ type, were selected and the fluoride concentrations of each were compiled. **Figure 2.2** shows the distribution of fluoride concentration in groundwater in Sri Lanka from the above survey. As shown in the figure, high concentration of fluoride occurs in several places and the study area is seriously affected.

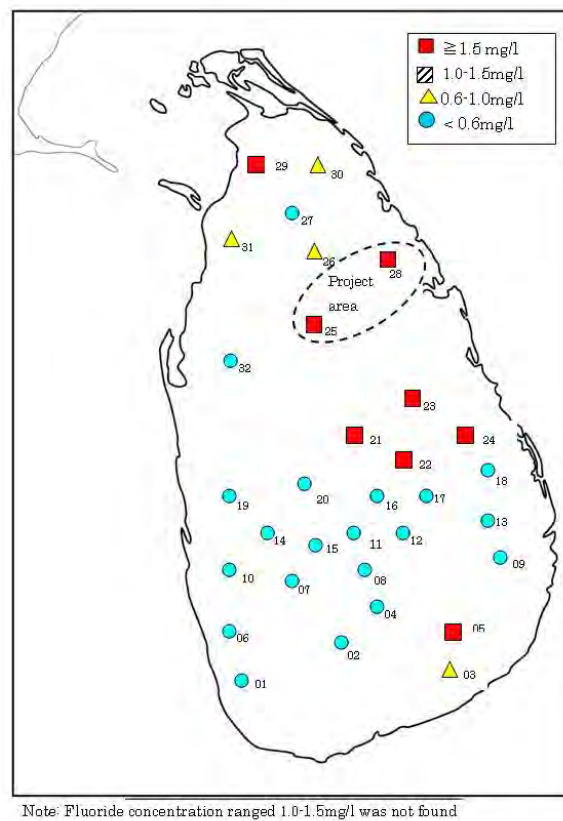

Source: "The Hydrogeochemical Atlas of Sri Lanka - 1985", Department of Geology, University of Peradenia

Figure 2.2 Distribution for Fluoride Concentration of Groundwater in Sri Lanka

(2) Distribution of Fluoride Concentration in the Study Area

For the horizontal distribution (refer to **Figure 2.3**), it can be said that in 5 out of 6 DSD fluoride exceeded 0.6 mg/l and levels in excess of 1.5 mg/l of fluoride were found in Madawchchiya, Kahadagasdigilliya and Horowpathana. In Kebitigollawa fluoride was less than 0.6mg/l.

For vertical distribution, though it was not clearly distributed, there is a tendency that groundwater in deep aquifers has a higher fluoride concentration than that in shallow aquifers. This is because groundwater generally occurs in association with geological materials containing soluble minerals and therefore higher concentrations of those minerals such as fluoride are normally expected in deep groundwater compared to shallow groundwater.

The JICA Study Team conducted the water quality examination of groundwater at 15 points mainly sampled from the existing CBO water sources. The results on fluoride concentrations are almost same as those in **Figure 2.3**.

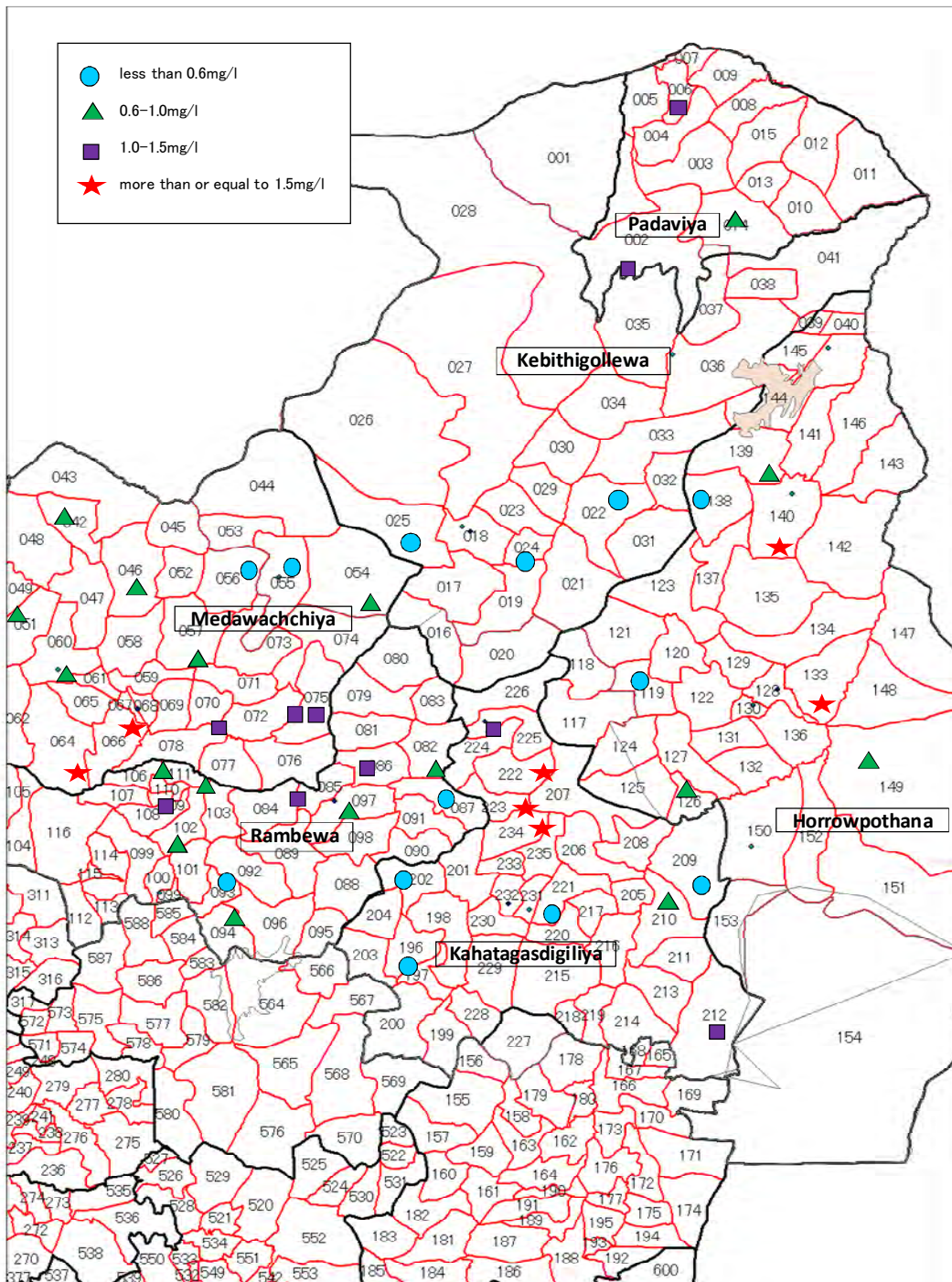

Figure 2.3 Fluoride Results for CBO Supply Water (Horizontal Distribution)

(3) Dental Fluorosis

Dental fluorosis has been recognized as an endemic problem affecting different areas of Sri Lanka with naturally occurring fluorides in drinking water. In 2002-2003, the National Oral Health Survey was conducted by the Ministry of Health and Nutrition under cooperation of WHO. Using such data, the CFI (Community Fluorosis Index) in each district was calculated by

the JICA Study Team. Though 12, 15 and 35-44 age of people were surveyed in the said survey, only the results of 12 age were extracted and used as dental fluorosis significantly occurs until such age.

The CFI is calculated according to the following formula. The weightage is defined based on the classification of cases

$$CFI = \sum \text{weightage} \times \text{number in each score group} / \text{number of cases examined}$$

If the CFI is above 0.6, generally it can be said that dental fluorosis is a public health problem in the area.

(4) Prevalence of Dental Fluorosis

The prevalence of dental fluorosis was evaluated by CFI. The said survey results and calculated CFI are shown in **Figure 2.4**.

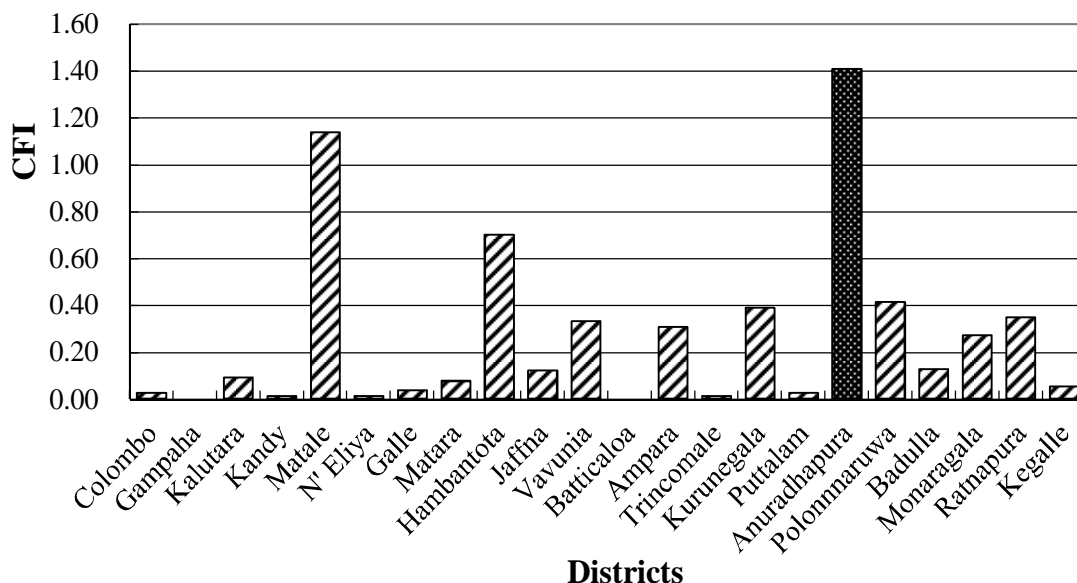

Figure 2.4 Comparison of CFI

(5) Comparison and District-wise Distribution of Dental Fluorosis

Based on the calculated CFI, the comparison of Anuradhapura with other districts and CFI distribution is shown in **Figure 2.5**.

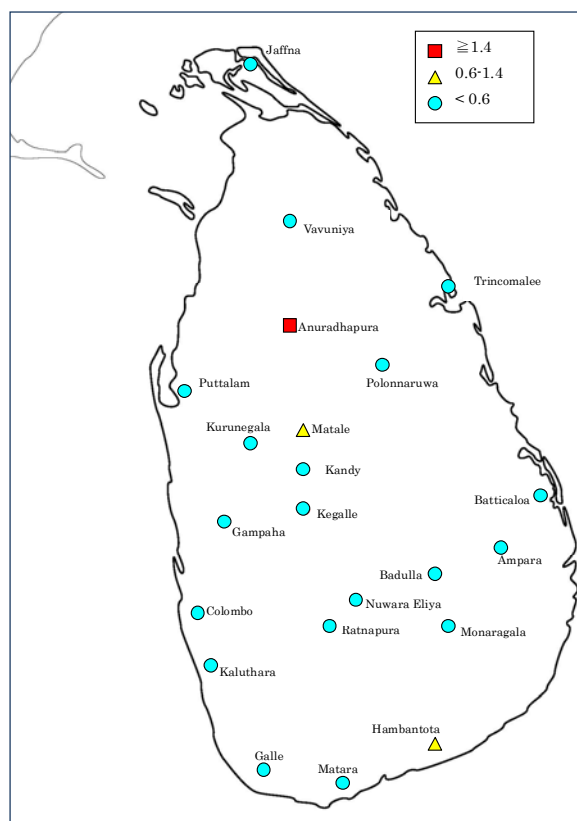

Figure 2.5 District-wise of CFI

(4) Conclusion

There was a distinct regional variation in the prevalence as well as severity of dental fluorosis in the districts of Anuradhapura and Matale followed by Hambantota. Anuradhapura district had the highest CFI at 1.41. As stated previously if the CFI is greater than 0.6, then this is a public health problem and as such immediate countermeasures are required in Anuradhapura district. Obviously one of causes of a high CFI is the high fluoride level in drinking water and therefore a safe drinking water supply is urgently required.

2.5.3 Chronic Kidney Diseases (CKD)

Chronic kidney disease (CKD) is a progressive loss in renal function over a period of months or years. CKD is an emerging health problem and it has a high economical cost on the patient, family, community and health system. In recent years, an increase in CKD cases has been observed in some parts of the country especially in the North Central provinces.

(1) Classification of Criteria of Cases

Generally the severity of chronic kidney disease is classified into five stages, with stage 1 being the mildest and usually causing few symptoms and stage 5 being a severe illness with poor life expectancy, if untreated. However, severity of CKD was not classified and individual patients

were simply counted in the following two surveys. In the surveys CKD was identified by a blood test and testing of a urine sample.

(2) Prevalence of CKD

1) Prevalence of CKD in some selected area in Sri Lanka

In 2010, a survey was carried out by Peradeniya University and this showed that Medwachiya, which is a part of the study area, had the highest prevalence of CKD among the adult (more than 18 years) population at 3.7% and 5% of the overall population, in comparison to other regions surveyed. **Table 2.6** shows the prevalence of CKD. It can be said that the study area covers locations where there are public health problems.

Table 2.6 Prevalence of CKD in Some Selected Area in Sri Lanka

| Province | North Central | North Central | Uva | Central | Southern | Eastern |
|------------------------------|---------------|---------------|----------------|------------|-------------|---------|
| Region | Medawachchiya | Huruluwewa | Girandurukotte | Yatinuwara | Hambanthota | Ampara |
| Year surveyed | 2003 | 2001-2005 | 2006 | 2004 | 2008 | 2008 |
| Sample size | 4,107 | 233 | 1,345 | 253 | 4,023 | 3,232 |
| CKD prevalence >18 years (%) | 3.7 | 3.2 | 3.9 | 3.2 | 2.53 | 2.2 |
| Overall Population (%) | 5 | 0.2 | 4 | 3.2 | 3.49 | 3.15 |

Source: Chronic kidney diseases of uncertain etiology (CKDue) in Sri Lanka, 2010

2) DSD-wise prevalence of CKD in North Central Province

Since 2003, the Provincial Department of Health Services has also conducted a DSD-wise CKD prevalence survey in the North Central Province. As the survey periods were different in each district, the data were averaged by the JICA Study Team, in order to facilitate comparison with each other.

(3) DSD-wise Distribution of CKD prevalence

From the survey on DSD-wise prevalence of CKD in the North Central Province, the prevalence in each DSD were compared as shown in **Figure 2.6**. As shown in the figure, the distribution on the prevalence of CKD is not equal, with the highest rates in Medawachchiya, Kebitigollewa and Padaviya, which are all within the study area.

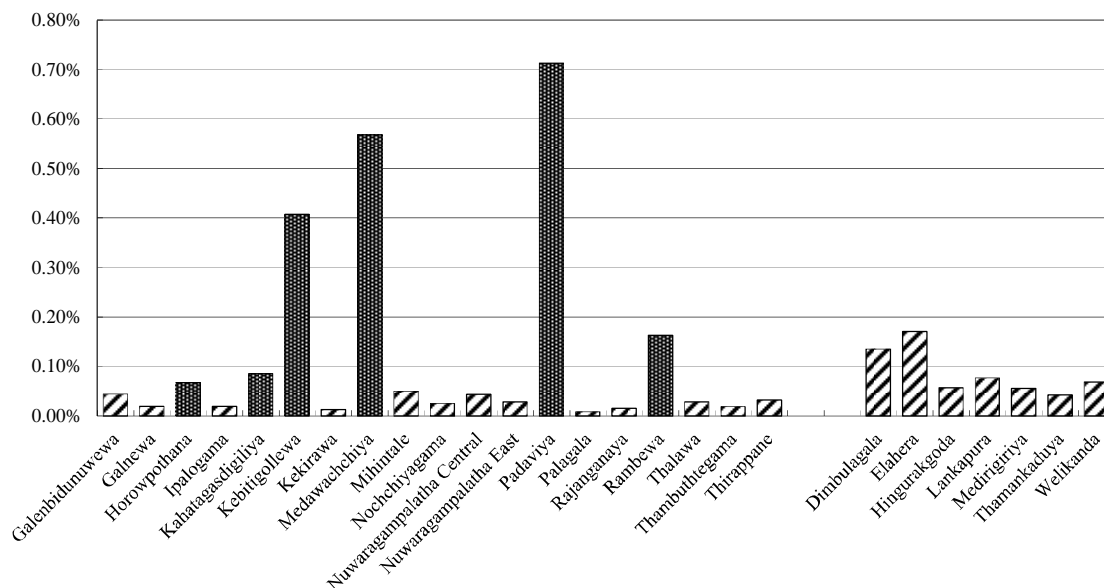

Figure 2.6 DSD-wise Distribution of CKD in North Central Province

(4) Conclusion

Compared to dental fluorosis, the causes of CKD are still unclear. For example, in Padaviya and Medawachchiya there are high levels of fluoride in drinking water and high levels of prevalence of CKD. On the other hand, in Kebitigollewa the level of fluoride in drinking water is low, but the prevalence of CKD is high. More detailed investigation will be needed to identify the cause(s) of CKD. However, at least it is considered that high fluoride levels of drinking water causes worsening CKD for CKD patients. Provision of treated surface water supply which is able to supply lower levels of fluoride will help to protect people’s daily life.

2.5.4 Necessity of the Project

As mentioned above, the necessity of the project can be summarized as follows:.

The people in the study area are facing the following problems regarding the principal water source and existing water supply schemes.

- According to the Census 2011, 75.4% of the people in the study area rely on groundwater as the principal water source and 18.9% of the people use tap water through the NWSDB’s and CBO’s water supply schemes. However the water source of such water supply schemes is groundwater with a few exceptions
- The people in the study area are forced to be engaged in the water-fetching work for a distance longer than that in other districts.
- Four out of five persons are exposed to the risk of fluorosis in the study area.
- Many existing CBO’s water supply schemes have experienced the water shortage during the dry season and cannot maintain the 24-hour water supply.

- Most existing CBO's water supply schemes have a variety of problems in structure, designing and operation.

Then water quality problem. Water quality of drinking water sources is an important issue which is directly related to the health of residents. Therefore, a groundwater quality survey of the current drinking water source was conducted. As a result, it was found in the survey that the most significant problem is the high concentration of fluoride. It was also confirmed that dental fluorosis due to high level fluorosis has occurred in Anuradhapura and the prevalence is higher than in other districts.

Removal of fluoride from the current groundwater sources is unrealistic from the viewpoint of technical and economic considerations. Therefore, it is urgently necessary to proceed with a project which utilizes surface water sources with low fluoride concentration. In addition, although Anuradhapura has been known as an area with a high prevalence of CKD, DSDs with a high prevalence of CKD were also found within the project area. However, no clear cause of CKD has been identified yet. For example, the project survey found that some DSDs showed a high prevalence of CKD with high fluoride concentration in drinking water sources, but in other DSDs there was no relationship between the CKD and fluoride concentrations. However, even if it is not possible to identify the causes of CKD, at least it is considered that high fluoride levels of drinking water causes worsening CKD for CKD patients⁶. Conversion to surface water sources which is able to supply lower levels of fluoride will significantly contribute to residents health.

As mentioned above, in order to solve the current water quantity and quality problem, it is essential to implement this project promptly.

⁶ *Based on the talk of Dr. Akio Koizumi, Professor of Graduate School of Medicine, Kyoto University, Kyoto, Japan*

CHAPTER 3 EXISTING WATER SUPPLY FACILITIES IN THE STUDY AREA

3.1 Water Supply Schemes in Anuradhapura District

Water supply schemes in Anuradhapura District are classified into those operated and maintained by NWSDB and Community-Based Organizations (CBOs) as shown in **Figure 3.1**. Water supply schemes under CBOs are further categorized into those constructed under ADB 3rd and 4th projects and Community Water Supply and Sanitation Project (CWSSP) under the WB’s assistance, but they are hereinafter named generically CBOs.

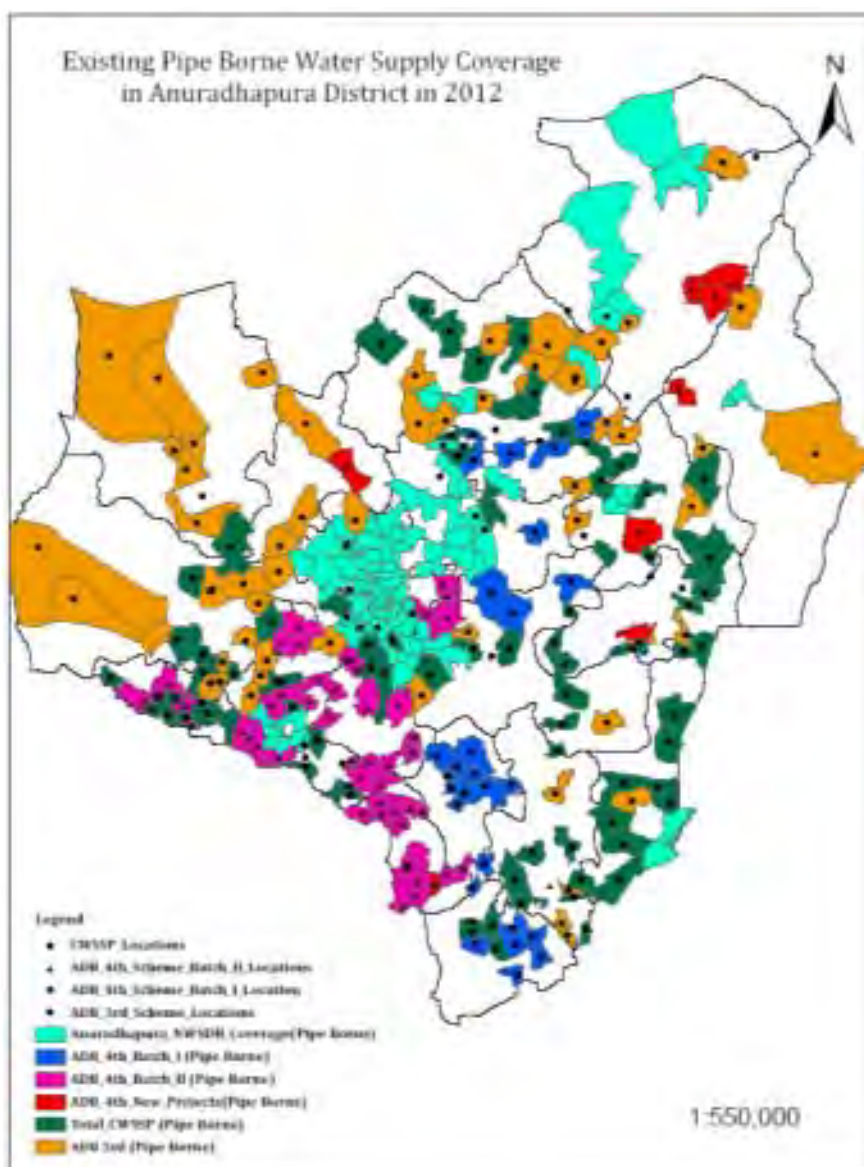

Note: As shown in **Table 3.1**, NWSDB has 18 water supply systems in Anuradhapura District, but some of them are not shown herein.

Figure 3.1 Water Supply Schemes under NWSDB and CBOs in Anuradhapura District

Water supply schemes in Anuradhapura District are summarized as shown in **Table 3.1**.

Table 3.1 Water Supply Schemes in Anuradhapura District

| | |
|---|---------|
| No of families | 171,060 |
| Population | 855,304 |
| Water Supply Schemes - NWSDB | 18 |
| No of service connections - NWSDB | 54,220 |
| Total No. of Beneficiaries - NWSDB | 325,320 |
| Piped water coverage - NWSDB | 37% |
| Rural Schemes Coverage - CBO | 19% |
| Total Piped Water Supply Coverage in the District | 56% |

Source: NWSDB RSC(N/C)

Note: A water supply scheme means the working unit in NWSDB, which is not necessarily established based on the service area of each water treatment plant. The large-scale water treatment plant or project is handled as one of working units, therefore there may be separate water supply schemes for a water treatment plant and water transmission and distribution system under one water supply system. The number of water supply schemes in **Table 3.1** shows the number of independent water supply systems.

The CBO organizes the people and participates the distribution pipe installation work in the form of labour contribution using the materials provided by the government in the rural areas and is responsible for operation and maintenance of water supply facilities under a self-support accounting system placing the person-in-charge after its completion. However, most of CBOs are facing the difficulties in inadequate quantity of water supplied, deteriorating quality of water, increasing cost, inadequate revenue, lack of technical expertise and social and managerial problems.

NWSDB, in response to the requests from the CBOs and other agencies concerned, has taken the following steps to mitigate above situation.

- Establishment of rural water supply and sanitation units in all districts to provide necessary back up support for CBOs.
- Amending NWSDB act to facilitate activities of CBOs
- Enactment of bylaws
- Establishment of Credit Development Fund
- Enhance facilities for water quality testing
- Strengthening of coordination of sector partners by provincial level coordination meetings

3.2 Existing Water Supply Facilities under NWSDB in Anuradhapura District

There are 24 water supply schemes operated by NWSDB (NC). Out of these 24 schemes, 18 are located in Anuradhapura District, whereas six are located in Polonnaruwa District.

Five schemes in Anuradhapura District are located in the study area, namely Kebithigollewa, Kahatagasdigiliya, Horowpothana, Medawachchiya and Padaviya.

The large- and medium-scale schemes mostly use surface water and with full treatment used, typically pre-chlorination + aeration + sedimentation + rapid sand filtration + post-chlorination. The small-scale schemes are using ground water (bore holes and tube wells) with chlorination for treatment. The development of water supply started in Anuradhapura Town in 1972 and expanded to the fringe areas to the east and north in the 2000's. Other medium-scale schemes were developed in the 1980's and small-scale schemes in the 1980-90's.

Usually mechanical and electrical equipment in water treatment plants and pump stations has deteriorated 20 to 30 years after construction. Therefore, some facilities which were constructed in the 1980's need rehabilitation or augmentation due to the increase in water demand.

The water supply system in NWSDB RSC(N/C), supplies water 24 hours, 7 days a week, except when there is a power failure, repair of leakage etc, which occasionally occurred.

As for the quality of water, high fluoride concentrations and hardness were recorded in the water, which is supplied from some water supply systems which have ground water sources, such as Medawachchiya, Padaviya, Kahatagasdigiliya, Horowpothana, Eppawala and Kerira High fluoride concentrations and hardness were recorded in the dry season between June and September.

3.2.1 Organizational

(1) Operation and Maintenance Organisation

The sound operation and maintenance (O&M) of the facilities after completion entails an organisation that is ready, capable, and skilled in performing the required works. Proper and rapid response is also essential in maintaining and repairing mechanical and electrical equipment at the water treatment plants and pumping stations, as well as the water transmission and distribution pipelines. Lastly, water quality management has to ensure compliance with the national standards.

1) The Operations Section

Certain criteria need to be satisfied for an organization to have a good O&M system. Among these criteria are: (i) Having a rational O&M organisational structure in place, together with written job descriptions for each position that clearly define the O&M roles and responsibilities; (ii) Having competent and trained O&M personnel to execute the operation and maintenance activities; (iii) The availability of tools, equipment, vehicles, instrumentation, and chemicals to perform the required O&M work; (iv) The presence of stores to provide spare

parts and supplies for prompt repair and maintenance work; (v) The availability of outside contractors to provide quality O&M services; and (vi) An operation and maintenance program that is customized to the needs of the organization.

a) Structure of the Operations Section

This section performs all operation and maintenance activities of the regional support centre. While the organisational structure is more inclined to show and highlight positions and grade levels (ranks) of the section personnel, in actuality, the section is divided into functional units. These are (i) The Operation and Maintenance (O&M) Unit, (ii) The Rural Water Supply (RWS) Unit, (iii) The Commercial Unit, (iv) The Regional Laboratory, and (v) The O&M Workshop. Among these five units, it is the O&M Unit that is also organised spatially, or along geographic (service) areas. The total number of personnel IN the Operations Section is as follows: Posts in the Approved Cadre, 391, of which 315 posts have been filled up, and 76 posts remain vacant. In addition, there are 31 outsourced / casual personnel.

(2) Organisation of Water Supply Schemes in the Study Area

There are a total of 33 water supply schemes under the RSC – 21 in the Anuradhapura district, and 12 in the Pollonurawa district.

Each scheme is headed by an OIC who holds the cadre category/designation of engineering assistant (EA).

A closer look at the water supply schemes shows different types of schemes – purely distribution or purely production-type schemes; water treatment plant-type schemes; a mix of production, treatment and distribution. The operations of the mixed schemes encompass a wide range of water utility activities such as production and treatment, distribution, billing and collection and other consumer services, human resources and support services. The number of O&M personnel, therefore, is dependent on the type of WSS.

(3) Profile of the O&M Personnel in the Study Areas

A survey was undertaken on the O&M personnel in the water supply schemes in the study areas to ascertain their profile in terms of age, employment status, number of years of employment with NWSDB, educational level and trainings received. Of the 34 personnel surveyed, 64.71% had permanent employment status, 8.82% were casual, while the rest did not indicate their status. This is consistent with the fact that labourers, caretakers and meter readers are outsourced in the scheme levels.

As to the educational attainment of the O&M personnel, a low level of education where approximately 65% did not reach high school and 3% did not possess any formal education.

Ideally, regular and on-the-job training should be made available for personnel who have low

levels of education and whose jobs are skills-based. However, such is not the case for the O&M personnel in the WSS surveyed.

(4) O&M Practices of the WSS

A good operations and maintenance program on the WSS level consists of two basic components – standard operating procedures and O&M records. The WSS surveyed could not present written standard operating procedures that describe how each operational task is to be performed. However, the OICs/EAs concerned stated that by experience and by training, and with their guidance and supervision, the personnel of the WSS visited possess sufficient technical knowledge in operating and maintaining WSS equipment.

While not all WSS has stores or a storekeeper position, the OIC is tasked to manage the inventory of fixed equipment and consumables. Reports and records to monitor and control the inventory of different supply types and spares parts, are: (i) Inventory Report on Program Usage, (ii) Stores Register Record; (iii) Material Issue Note; and (iv) Material Transfer Note.

In the maintenance of the transmission and distribution systems, water towers and associated hardware are inspected regularly, while pipelines and fittings are visually inspected for leaks. In addition to this, the consumers are active in reporting observed leaks to the WSS office for its immediate repair. Non-functioning and malfunctioning water meters are also reported to the WSS office either by the meter readers or the consumers themselves after which these are either repaired, or if beyond repair, are replaced.

As mentioned earlier, preventive and corrective maintenance are performed on pumps, motors, motor control panels, valves, instrumentation, control equipment, chemical mixing tanks and associated hardware, flocculators and sedimentation tanks, filters, chlorinators and building structures by both the WSS personnel and the O&M workshop team / unit at the RSC(N/C). Corrective maintenance work that cannot be done by the RSC(N/C) is brought to the attention of the Head Office, or is referred to outside service contractors.

3.2.2 Technical

(1) Operation

The water supply system is operated by a team of operators, caretakers, meter readers, drivers, labours etc. headed by OIC (Officer-in-Charge). The team operates and monitors the pumps and treatment plants in the system. The OIC has the responsibility to operate, monitor and maintain the water supply system. At present most of water supply facilities are operating smoothly.

The OIC has to report monthly on the operation to the Operation Manager (O&M) in RSC(N/C).

The monthly report covers all the aspects relating to the system operation and contains the following information.

- (a) Treated water produced (m³/month)
- (b) Major downtime (hrs)
- (c) Power/chemical consumption
- (d) Nos. of staff
- (e) Billing
- (f) Leak
- (g) Defective water meters etc.

The above table is prepared by RSC(N/C) to monitor the NRW in each water supply system. The NRW is accurately monitored and calculated by using meter readings of bulk meters and water meters from all connections. The range of NRW is between around 10 to 35%, with the exception of two locations. In the large-scale and old systems NRW is higher at more than 30%, in comparison with that in the small-scale and new systems, where it is less than 20%. The table also shows all NRW related information, such as number of leaks, illegal connections, defective meters, zero-bills and estimated bills. By close monitoring of the information, NWSDB endeavors to minimize NRW.

Along with NRW, NWSDB RSC(N/C) is conscious on cost and expenses, and all necessary information.

(2) Maintenance

Maintenance services mainly consist of leak repair works and mechanical/electrical repair works. The leak repair works are mostly implemented by OIC's team based on leaks reported, as breakdown maintenance. As for mechanical/electrical equipment, the Regional Workshop is implementing breakdown and preventive maintenance.

1) Breakdown Maintenance

The following table shows major repair works and implementing organizations. Due to lack of maintenance machines and manpower, some repair works are transferred to the Central Workshop at NWSDB Head Office and some works are ordered to be undertaken by private companies.

It is cost effective to utilize the Central Workshop or private companies, instead of having all machines and manpower to meet peak repair works or complicated works which rarely occur.

All maintenance services done by the Regional Workshop of NWSDB RSC(N/C) are recorded on a Workshop Job Card, which includes Scheme/ Job Description/ Cost (material,

machine, labor, transport, others and overheads) for cost control.

2) Preventive Maintenance

Preventive maintenance is conducted to keep equipment working and/or extend the life of the equipment. The Regional Workshop of NWSDB RSC(N/C) in principle implements preventive maintenance for all water supply systems once a month, and usually it takes 15 working days. By the end of every month, the workshop plans the schedule of the preventive maintenance, and implements accordingly, considering the urgent requirements for breakdown maintenance.

| | |
|----------------------------------|--|
| Monthly Inspection Check List | centrifugal pump, borehole pump, air blower, compressor, generator (including motor and starter) |
|----------------------------------|--|

Beside the monthly preventive maintenance, operators at the plants or the stations implement daily inspection. The inspection consists of checking appearance, unusual noise, vibration, temperature, tightness of bolts, gauged pressure etc.

| | |
|--------------------------------|---|
| Daily Inspection Check List | centrifugal pump, borehole pump, air blower, compressor, generator, motor, clarifier, mixer |
|--------------------------------|---|

3.2.3 Financial

North Central Regional Office of NWSDB covers this project site. Therefore, the financial situation of this regional office is analyzed at first.

The accountant of the office provided JICA Study Team with “Income and Expenditure Statements” from 2006 to 2011. They can be shown in **Table 3.2**.

Table 3.2 Revenues and Expenditures of North Central Office

(Unit: Rs.)

| Item | Year | 2006 | 2007 | 2008 | 2009 | 2010 | 2011 |
|-----------------------------------|------|--------------------|--------------------|--------------------|--------------------|--------------------|--------------------|
| Sales of water | | 211,529,041 | 228,146,633 | 248,423,362 | 404,774,818 | 438,335,713 | 481,521,169 |
| Other operating income | | 24,386,682 | 48,339,366 | 83,346,790 | 72,501,027 | 77,598,820 | 67,715,576 |
| Operating Income | | 276,485,999 | 235,915,723 | 331,770,152 | 477,275,845 | 515,934,533 | 549,236,745 |
| Direct operating expense | | 184,099,380 | 226,161,790 | 283,311,215 | 317,241,696 | 369,840,475 | 401,377,546 |
| Personnel cost | | 97,070,685 | 125,864,817 | 140,762,285 | 155,568,143 | 186,361,433 | 187,710,103 |
| Utility cost | | 41,276,082 | 47,198,858 | 77,254,487 | 66,683,530 | 78,007,992 | 89,072,286 |
| Chemical cost | | 16,478,972 | 19,083,357 | 25,471,952 | 29,157,320 | 26,791,869 | 27,156,443 |
| Repairs & maintenance | | 10,767,587 | 12,471,710 | 7,489,222 | 24,934,072 | 29,290,055 | 31,068,927 |
| Establishment expenses | | 6,941,355 | 8,693,522 | 11,138,275 | 14,387,781 | 15,586,225 | 17,658,668 |
| Rent, rates, taxes, etc. | | 11,564,699 | 12,849,526 | 21,194,994 | 26,510,850 | 33,802,901 | 48,711,119 |
| Other operating expenses | | 11,791,880 | 26,482,579 | 31,312,587 | 34,738,424 | 40,848,121 | 32,408,216 |
| Operating Expenditure | | 195,891,260 | 252,644,369 | 314,623,802 | 351,980,120 | 410,688,596 | 433,785,762 |
| Operating Surplus/ Deficit | | 40,024,463 | 23,841,630 | 17,146,350 | 125,295,725 | 105,245,937 | 115,450,983 |

Source: North Central Office, NWSDB

The table shows surplus every year in the past six years. From 2009, the surpluses are more than 100 million Rs. reflecting the tariff raise in 2009. Therefore, North Central Office can sustain itself financially from the viewpoint of cash flow. However, the operating expenditures do not include depreciation. In addition, the account does not include non-operating account such as finance costs. The Head Office manages those matters so that it is necessary to analyze the whole financial aspects of NWSDB as follows.

Water Tariff

The latest water tariff was issued on 18 September, 2012 and in force from 1 October 2012 in accordance with the National Water Supply and Drainage Law No.02 of 1974.

3.2.4 Water Supply Development Plan of NWSDB in Anuradhapura District

Currently 12 water supply projects are nominated for future development in Anuradhapura District.

Two projects are under process for implementation. The Ministry of Water Supply & Drainage nominated five "Priority Water Supply Projects" in June 2011, and both Anuradhapura South Integrated WSP - Phase II and Anuradhapura North Integrated WSP were selected. These five projects were planned to be implemented by potential investors or project developers on a design build basis supported with funding arrangement.

Anuradhapura South Integrated WSP - Phase II is under EOI (Expression of Interest) evaluation, while, the EOI for the Anuradhapura North Integrated WSP was canceled, because JICA dispatched their study team for a preparatory study to identify the potential for funding. All

other development projects have a small project cost.

3.3 Existing Water Supply Facilities under NWSDB in the Study Area

There are 56 water supply schemes in total in the project areas including 50 numbers of CBOs facilities and 6 number of NWSDB facilities out of which Rambewa is not an independent system but a part of Anuradhapura North Water Supply Scheme (WSS) and Mihintale WSS with both water sources in Nuwarawewa.

Table 3.3 below shows the number of existing water supply schemes and the served population in each DSD, in which it is apparent that the service coverage in Rambewa and Medawachchiya DSD is higher than in other areas (34.1% and 30.9% respectively), with coverage in Horowpothana (13.8%) and Kebithigollewa (16.6%) being lower than in other areas. There are only six NWSDB supply facilities located in six different DSDs, and approximately 27% of the population are served by NWSDB and the remainder by CBOs.

Table 3.3 Existing Supply Schemes and Served Population

| DSD | No. of Water Supply Schemes | | | Served Population | | | | Population (2012) |
|-----------------------|-----------------------------|------|-------|-------------------|-------------------|-------------------|--------------|-------------------|
| | NWSDB | CBOs | Total | NWSDB | CBOs | Total | Coverage (%) | |
| Wahalkada | | | | | | | | |
| Padaviya | 1 | 3 | 4 | 2,191 | 4,675 | 6,866 | 28.5 | 24,130 |
| Kebithigollewa | 1 | 3 | 4 | 2,585 | 1,165 | 3,750 | 16.6 | 22,555 |
| Horowpothana | 1 | 7 | 8 | 705 | 4,005 | 4,710 | 13.8 | 34,044 |
| Kahatagasdigiliya | 1 | 13 | 14 | 3,656 | 8,760 | 12,416 | 32.1 | 38,688 |
| Sub-total | 4 | 26 | 30 | 9,137 | 18,605 | 27,742 | 23.2 | 119,417 |
| Mahakanadarawa | | | | | | | | |
| Medawachchiya | 1 | 13 | 14 | 4,630 | 9,905 | 14,535 | 30.9 | 47,100 |
| Rambewa | 1 | 11 | 12 | 2,139 | 10,160 | 12,299 | 34.1 | 36,024 |
| Sub-total | 2 | 24 | 26 | 6,769 | 20,065 | 26,834 | 32.3 | 83,124 |
| Total | 6 | 50 | 56 | 15,906 (7.8%) | 38,670 (19.1%) | 54,576 (26.9%) | 26.9 | 202,541 (100%) |

NWSDB Facilities in the Study Area

In the project areas, there are six NWSDB water supply facilities, however source of Rambewa system is out of the Project area although some of GNDs are included in the Project area. Therefore, Rambewa is excluded in this section. **Table 3.4** shows general information on the five NWSDB's facilities.

Table 3.4 NWSDB Facilities (General Information)

| Facility Name | Starting Year | Served Pop | System Capacity (m ³ /d) | Water source | | Storage | | Distribution Pipes | |
|-------------------|---------------|------------|-------------------------------------|--------------|-------|----------|----------------------|--------------------|------------|
| | | | | Type | nos. | Type | Capacity | Type | Length (m) |
| Padavia | 1990 | 2,191 | 578 | Deep | 3 | Ground | 40m ³ | PVC | 13,205 |
| Kebithigollewa | 1973 | 2,585 | 677 | Deep | 3 | Elevated | 225m ³ | PVC | 35,832 |
| Horowpothana | 1979 | 705 | 137 | Deep | 1 | Elevated | 50m ³ | PVC | 3,150 |
| Kahatagasdigiliya | 1982 | 3,656 | 893 | Deep | 1 | Elevated | 100m ³ | PVC | 26,200 |
| Medawachchiya | 1965 | 4,630 | 1,062 | Deep/Shallow | 5 / 2 | Elevated | 135m ³ x2 | PVC/AC/DI | 56,491 |

The population served with water by NWSDB is 14,000 and average service coverage is 47.5%. NWSDB facilities in the area started their operation in the period between 1964 and 1989. The oldest facility is Medawachchiya system. System capacities are ranging from 137 to 1,062 m³/day, and all of their water sources rely on ground water. The total capacity of storage tank is 685 m³, and all storage tanks are of the elevated tank except Padaviya.

Distribution pipes are PCV pipes except in Medawachchiya, where ACP (Asbestos Cement Pipe) are partly used for 50 – 225 mm in diameters. There is no Non Revenue Water data available in these systems.

In the survey, only three water quality items of pH, Turbidity and Fluoride were collected as shown in **Table 3.5**.

Table 3.5 Water Quality of NWSDB Facilities in the Area

| Facility Name | pH | Turbidity | Fluorine |
|-------------------|------|-----------|----------|
| Padaviya | 7.65 | 0.49 | 0.32 |
| Kebithigollewa | 7.01 | 1.29 | 0.11 |
| Horowpathana | 7.64 | 6.13 | 1.42 |
| Kahatagasdigiliya | 7.62 | 0.50 | 1.90 |
| Medawachchiya | 7.53 | 0.50 | 0.77 |

3.4 Existing Water Supply Facilities under CBO in the Study Area

3.4.1 General

(1) General

In the Anuradhapura Integrated Water Supply Project Area, a number of small scale water supply systems have been located under the operation and maintenance of Community Based Organizations (CBOs) which funded by ADB-3rd or ADB-4th. In addition, Community Water Supply and Sanitation Program (CWSSP) have been funded by World Bank (WB). However, as a CBO supply system, these all water facilities have been operated at the moment.

The survey aims to search the followings.

- General Information: name of CBO, location, contact details, year of establishment, year/period of operation, service area, population.
- Water supply system details including, type of water source, treatment system, water storage and detail of distribution system. Supply conditions such as: supply service (continuous/intermittent), supply pressure, and estimated water loss.
- Details of operation and maintenance including managerial and operational personnel, consumption of power / fuel, chemicals, repairs / replacements etc.
- Financial conditions including revenue (water tariff, connection fee and other revenue) and expenditure including annual cost of personnel, power, chlorine, cost of maintenance and depreciation.
- Willingness to connect to new surface water system including proposed tariff.
- Relevant data and information of service area, system layout and drawing of major facilities.

In accordance with the survey, seven CBO have not been operated nor started operation as described herein below.

- No.27 Gonumariyaya CBO (Kebithigollewa DSD): Project has not been implemented; thus no water supply facility exists.
- No.26 Al Naja CBO (Kebithigollewa DSD): Construction work has not been completed; thus supply of water has not been commenced.
- No.36 Nilmini CBO (Kahatagasdigiya DSD): In 2010 the water pump was broken due to lightning; since then no water has been provided.
- No.47 Tristar CBO (Horowpothana DSD), No.48 Alhidra CBO (Horowpothana DSD) and No. 49 Adhikawa CBO (Horowpothana DSD): Construction has been completed, but the CBO organizations have not been formally organized and water is used without proper management.
- N0.41 Pinibindu CBO (Kahatagasdigiya DSD): No CBO has been organized, as there is no proper water source and people rely on rainwater.

Figure 3.2 is a location map of CBO's facilities, which shows that the facilities are sparsely located over the project area.

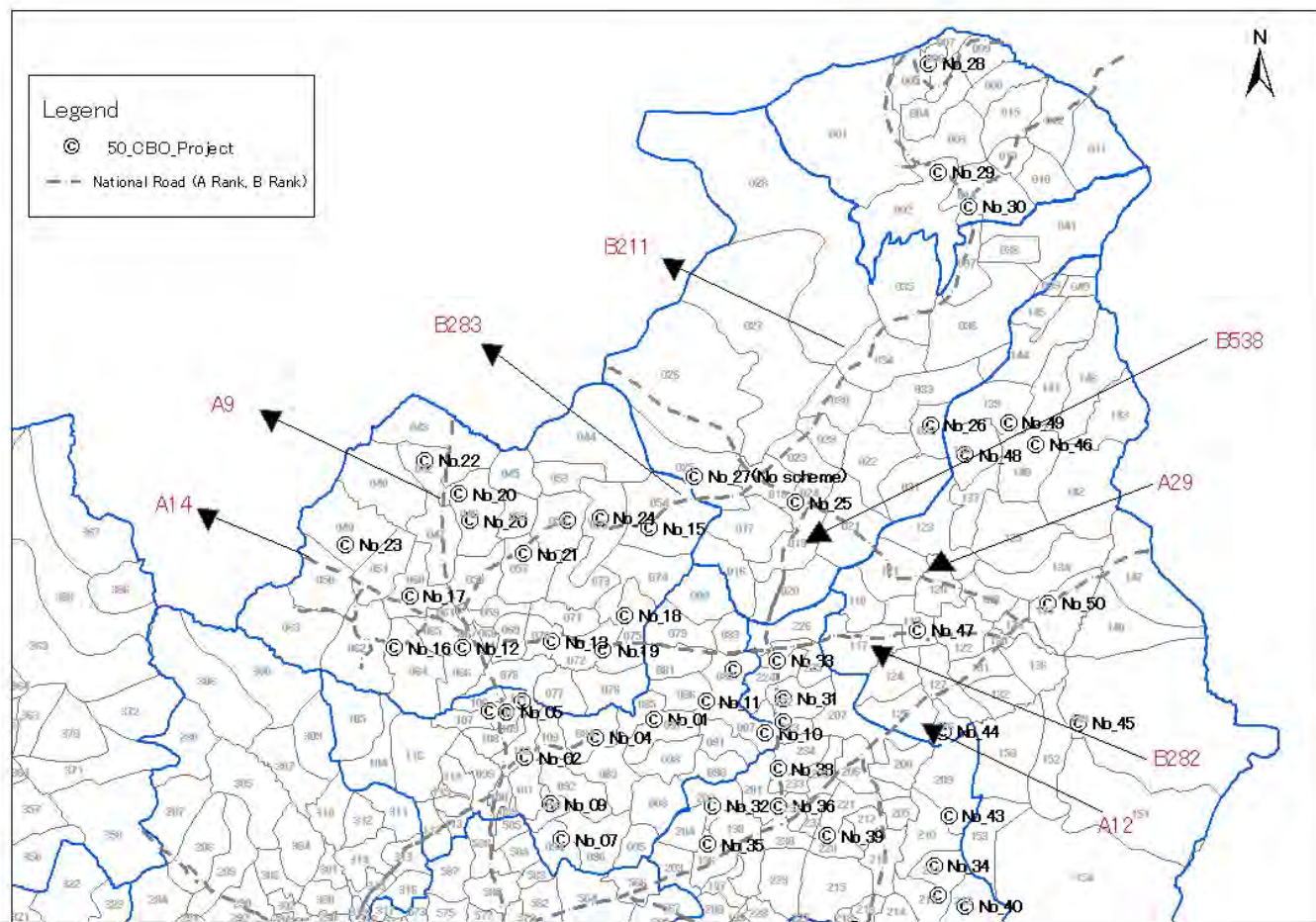

Figure 3.2 Distribution Map of CBO Facilities

The earliest operation of CBO’s facilities was commenced in the year 2003 and most of CBOs started their operation from the 2006 to 2009. All of CBO’s facilities are relatively new, and they are, more or less, still in good conditions and it is expected to be used in the future, with the exception of in the seven CBOs, as described earlier.

(2) Water sources

In the most of CBOs, ground water is used either by installation of shallow wells, deep wells or a combination of both. CBO No. 41 Pinibindu in Kahatagasdigiliya DSD relies on rain water because of the limitation of the water source, and only 60 people are served in this CBO service area.

Many CBOs stated that the systems have insufficient water quantity especially in dry season, insufficient supply pressure, poor and unsuitable water quality, etc.

The following are the problems that CBO’s managerial persons have stated during the field survey:

- 10 CBOs stated; “We have a problem in shortage of water during dry season.”
- 3 CBOs stated; “Not sufficient pressure in the line so that water could not reach the end of the system or higher places.
- 2 CBOs stated; “We have difficulties to further increase the number of connections to houses because of insufficient water.”
- 3 CBOs stated; “We cannot operate the system continuously due to low voltage of electricity.”

Present water sources are deep wells at 16 CBOs, shallow wells at 24 CBOs, both deep and shallow wells at 7 CBOs and rainwater at one CBO.

(3) Water Quality (See **Table 3.5**)

According to the field survey, there is no CBO which has treatment facilities, such as filters or aerations. Further, limited chlorination facilities were installed in the water supply facilities, Eight CBOs have experience of dosing hypochlorite in the elevated tanks either occasionally or consistently. Most of CBOs have not dosed chlorine due to either lack of skill relating to O&M or financial reason.

(4) Components of Facilities

In most CBO’s water supply systems, raw water is taken either from deep wells or shallow wells, then pumped up to elevated tanks, before being distributed by gravity to houses through PVC pipes. As shown in **Table 3.6** and **Table 3.7** the total storage capacity in all CBOs is 2,805 m³ and on average 58 m³ of storage capacity is provide in each CBO’s water supply system.

In accordance with the field survey, low water levels of elevated tanks are between 10 and 15 m from the ground level and water depth is about 2.1 m. Information of distribution pipes was collected from 48 CBOs. Distribution pipes are PVC type 600 (PN6) with nominal diameters of 25 mm to 150(OD160) mm. Many CBOs use small size of distribution pipe of less than 50(OD63) mm in diameter.

Table 3.6 Capacity of Elevated Tanks

| | |
|----------------|----------------------|
| No. of CBOs | 48 |
| Total Capacity | 2,805 m ³ |
| Ave. | 58.5 m ³ |
| Max. | 22.5 m ³ |
| Min. | 20 m ³ |

Table 3.7 Distribution Pipes

| | |
|----------------|-----------|
| No. of CBOs | 48 |
| Total Length | 392,299 m |
| Ave. | 8,173 m |
| Per Connection | 51 m |

3.4.2 Summary of Survey Results

(1) Existing Conditions in CBO Water Supply Schemes

The conditions of existing water supply schemes are summarized for the **Table 3.28** as follows.

- CBOs supply schemes are presently the major water supply system where about 70% of served population or 19% of total population of the Project area is supplied by CBO's system. Therefore, it is crucial to maintain CBO's system with sound manner.
- 44 CBOs out of 50 are functioned and most of CBOs have started their operation from the year 2006 or around.
- All elevated tanks other than S/No. 36 Kokmaduwa in Kahadagasdigilliya (leakages are observed) are sound to receive treated water by ANIWSP.
- Most of CBOs express their willing to connect to the treated water system constructed by the present project of Anuradhapura North Integrated Water Supply Project (ANIWSP), and they desire to keep operation and maintenance by themselves. (except one CBO – 10 Mimuth CBO was not willing to connect)
- Distribution pipe network is all PVC type 600 with the diameter ranging from OD 32 mm to 225 mm. The length of the distribution system varies depending on the size of CBSs schemes, ranging from 4.5 Km to 24 km.
- Bulk meter is not installed or not functioned in many CBOs, which makes difficult to monitor tendency of distribution water and monitor and control of NRW

(2) Problems in CBO Managed Water Supply Schemes

As a result of the survey, the existing facilities of CBOs are mostly in good conditions except a few CBOs. It is, however identified the problems in technical and non-technical aspects as listed below

- None of CBOs has 24-hour continuous supply. The reason are (1) shortage of raw water source of groundwater especially in dry season and (2) unstable power supply in some CBOs.
- High concentration of fluoride and also high hardness of well water are observed in many wells of CBOs.
- In several CBOs distribution pipe networks, where pipelines are less than OD65mm diameter, the pipe sizes are too small; hence water pressure at the distribution pipe end is not enough.
- Bulk meters are not installed or not functioned in many CBOs, which makes difficult to monitor distribution of water and to control NRW.
- Cash flow of the most of CBOs is positive, while their water tariff is relatively higher than that of NWSDB.
- Chlorination is, in principle not properly made. It is presumed that most of CBOs have used hypochlorite only occasionally or not used at all.

- Through the survey, many sketch of distribution networks are collected, however they are not accurate, and cannot be used for analysis. No updated information has been found.

Problems in technical and non-technical aspects

A: No master valves at water tanks and/or tube-well pumps are installed.(31 CBOs)

B: Leakage from tanks and/or pipeline (6 CBOs)

C: No operational valves (air valve, gate valve and wash-out valves, etc.) are installed.(14 CBOs)

D: Insufficient pressure due to under-sized pipes (5 CBOs)

E: No proper chlorination dosage.(22 CBOs)

F: Unstable electricity supply (power cut/voltage variation) (6 CBOs)

G: Invisible customer meters (1 CBO)

H: Malfunction of tube-well pump (1 CBO)

I: Little water in dry season (20 CBOs)

a: O&M records not succeeded due to change of committee member (1 CBO)

b: No administration office (24 CBOs)

c: No proper O&M record keeping due to insufficient training (6 CBOs)

d: No enough number of O&M staff (3 CBOs)

e: Poor management of billing system (meter reader does not read exactly) (1 CBO)

(3) Conclusion and Recommendations

- Most of CBOs' facilities are new and in good conditions. They are capable to receive bulk water supply from ANIWSP.
- All CBOs in operation (with the exception of one CBO) are willing to connect to the bulk water supply system and desire to maintain operation and maintenance by themselves.
- In order that the ANIWSP connects and supplies bulk water to the CBOs, the following technical and non-technical recommendations are taken into account:
 - Proper installation of valves such as air valve, wash out valve and sectional valve shall be made in CBOs' distribution lines.
 - On connecting to the ANIWSP, it is necessary to install bulk meter at the inlet pipe of each CBO's tank, which will be a scope of ANIWSP. In addition installation of another master meters at the outlet of CBOs tanks are recommended with the assistance by NWSDB.
 - Repair and rehabilitation of network is recommended where low pressure is observed resulting from unsuitable pipe sizes in a part of distribution system.
 - NRW is properly monitored and controlled with an assistance of NWSDB. Where NRW ratios are higher than 20%, counter measures will be taken.
 - With the assistance of NWSDB, necessary capacity building is conducted for CBOs managerial staff, which includes billing system, record keeping, technics of O&M, etc.

CHAPTER 4 PROJECTION OF POPULATION AND WATER DEMAND IN THE STUDY AREA

4.1 Basic Policy for Planning

The study area covers six DSDs (Divisional Secretary Divisions), namely, Padaviya, Kebithigollewa, Horowpothana, Kahatagasdigiliya, Medawachchiya and Rambewa which are located in the north-eastern part of Anuradhapura District with a population of 204,738 persons (estimated for the year of 2012) and an area of 2,740.48 km² forming the typical rural area. The people in this area mainly rely their drinking water source on groundwater through dug/tube wells, however due to a high content of fluoride in groundwater, the patience of dental and skeletal diseases occur. In addition, they say that a high prevalence of chronic kidney diseases (CKDs) is also attributed to the high fluoride concentration in Sri Lanka. In the study area, as described in **Chapter 3**, there are six water supply systems operated and maintained by NWSDB and 50 water supply schemes under CBOs. They are all small-scale water supply schemes with water sources in dug/tube wells except for one CBO system and mostly have a problem of high fluoride concentration in groundwater. Water shortage is also found in the many existing CBO systems especially during the dry season.

To solve these problems, the new water supply system is proposed to integrate the existing NWSDB and CBO water supply schemes under the following basic policy for planning:

- The water source will be converted from groundwater to surface water to meet the Sri Lanka drinking water standards. The surface water will be taken from the irrigation canals originated from Mahakanadarawa Tank and Wahalkada Tank for irrigational purpose.
- Taking into account the overall topography of the study area and the location of proposed water sources, the study area will be divided into two water supply systems, namely, Mahakanadarawa System covering Medawachchiya and Rambewa DSDs and Wahalkada System covering Padaviya, Kebithigollewa, Horowpothana and Kahatagasdigiliya DSDs.
- The proposed water supply systems will supply water to the existing service area under NWSDB and CBOs and the new service area currently not served,
- The study area is composed of 194 GNDs under six DSDs, out of which 60.8% of GNDs have a population density of less than 100 persons per km² and 87.6% of GNDs for less than 200 persons /km². Since the population is sparsely distributed in an extensive area as mentioned-above, it is clearly not cost-effective to develop ordinary water supply systems (hereinafter referred to as “ pipe borne water supply”). For this reason, some area will be covered by non pipe borne water supply systems in which safe water treated at water treatment plants will be delivered by water bowser to the water tanks strategically arranged to minimise the water-fetching works of the people (hereinafter referred to as “bowser water supply”).
- The new water transmission pipes will be connected to the elevated tanks of existing systems and the existing water distribution facilities will be used as they will be as much

as possible.

- Some out of the existing CBO systems will be excluded from the integration to the new water supply systems, if they have currently no problem in quality, quantity, operation, etc.

The design water supply is estimated in accordance with the flowchart as shown in **Figure 4.1**.

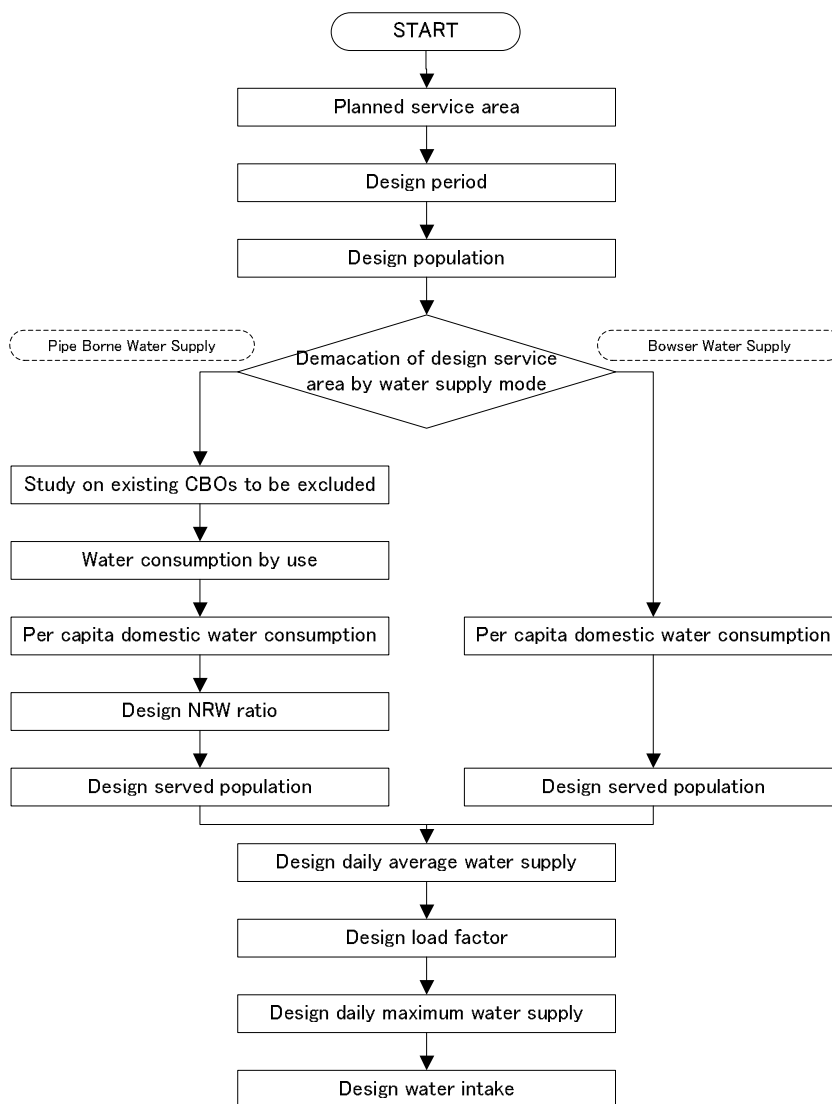

Figure 4.1 Flowchart of Design Water Supply Estimation

4.2 Estimation of Design Water Supply

4.2.1 Design Service Area

The design service area shall be six DSDs, namely, Padaviya, Kebithigollewa, Horowpothana, Kahatagasdigiya, Medawachchiya and Rambewa which are located in the north-eastern part of Anuradhapura District.

4.2.2 Design Period

NWSDB Design Manual (March 1989) describes that “As a general principle it is recommended that future urban schemes be designed for a 20-year planning horizon in two 10-year stages”. For reference, the Japanese design criteria recommend to set the target year at 15 to 20 years ahead. Therefore, it is reasonable to set the target year in 2034 with an interim target year of 2024 for staged construction.

4.2.3 Design Population

For the urban area of Anuradhapura District, the average growth rate in the period from 1981 to 2001 was 1.26%, marginally higher than the national average of 1.16%, as shown in **Table 4.1**. On the contrary, for the rural area that in the period from 1981 to 2001 was 1.19%, which is also a little bit higher than the national average of 1.16%.

Table 4.1 Historical Census Population

| | 1953 | 1963 | 1971 | 1981 | 2001 | 2012 |
|-----------------------------------|-----------------|-----------------|-----------------|-----------------|-----------------|-----------------|
| Population | | | | | | |
| Sri Lanka | 8,097.9 | 10,582.0 | 12,689.9 | 14,846.8 | 18,797.3 | 20,277.6 |
| Urban | 1,239.1 | 2,016.3 | 2,848.1 | 3,192.7 | - | - |
| Rural | 6,858.7 | 8,565.8 | 9,841.8 | 11,654.3 | - | - |
| Anuradhapura (% to Sri Lanka) | 229.3 (2.8%) | 279.8 (2.6%) | 388.8 (3.1%) | 587.9 (4.0%) | 745.7 (4.0%) | 855.6 (4.2%) |
| Urban | 18.4 | 32.9 | 38.8 | 41.4 | 53.2 | - |
| Rural | 210.9 | 246.9 | 349.9 | 546.5 | 692.5 | - |
| Annual Average Growth Rate | | | | | | |
| Sri Lanka | 2.8 | 2.7 | 2.3 | 1.6 | 1.16 | 0.71 |
| Urban | 2.8 | 5.0 | 4.4 | 1.1 | - | - |
| Rural | 2.8 | 2.2 | 1.8 | 1.7 | - | - |
| Anuradhapura | 7.4 | 2.0 | 4.2 | 4.2 | 1.25 | 1.33 |
| Urban | 5.9 | 6.0 | 2.1 | 0.7 | 1.26 | - |
| Rural | 7.5 | 1.6 | 4.5 | 4.6 | 1.19 | - |

Source: "Statistical Abstract 2010", Department of Census and Statistics

Source: "Population of Sri Lanka by District – Preliminary Report (Provisional) - 1", Department of Census and Statistics, April 20, 2012

The rural population in Anuradhapura District has increased from 246,900 in 1963 to 692,500 in 2001 or 2.8 times during this period. The annual growth rates of the national population were 2.7% in the period to 1963, and 2.3%, 1.6%, 1.16% and 0.71% in the subsequent periods to 1971, 1981, 2001 and 2012 respectively. Therefore, even though the agricultural development policy will be assumed, it is considered that the high growth rate which occurred in the period from 1981 to 2001 in Anuradhapura District cannot be expected in the future.

The GNDs in the study area are classified into four types in consideration of local conditions as shown below. The annual average growth rate of 1.2% for 1981 to 2001 is applied to GNDs adjoining the GNDs with the national roads, 0.3%-increased 1.5% to the GNDs with the national roads and 0.3%-decreased 0.9% to remaining GNDs except for the GNDs currently forming the urban centre of each DSD and its surrounding area to which 1.8% is applied due to the high potential for future development, since they are located at the crossings of national roads.

The population projection is summarized in **Table 4.2** (The GND-level population in Census 2012 was not available at the time of population projection.).

Table 4.2 Population Projection in the Study Area

| | Census | Estimated Population | | | Annual Average Growth Rate (%) | | |
|------------------|----------------|----------------------|----------------|----------------|--------------------------------|-------------|-------------|
| | 2001 | 2012 | 2024 | 2034 | 2012/2001 | 2024/2012 | 2034/2012 |
| Padaviya | 21,146 | 24,403 | 28,583 | 32,655 | 1.31 | 1.33 | 1.33 |
| Kebithigollewa | 19,457 | 23,007 | 27,661 | 32,276 | 1.54 | 1.55 | 1.55 |
| Horoupothana | 29,642 | 34,374 | 40,462 | 46,412 | 1.36 | 1.37 | 1.37 |
| Kahatagadigillia | 33,572 | 39,096 | 46,234 | 53,219 | 1.39 | 1.41 | 1.41 |
| Sub-total | 103,817 | 120,880 | 142,940 | 164,562 | 1.39 | 1.41 | 1.41 |
| Medawachchiya | 40,469 | 47,533 | 56,688 | 65,677 | 1.47 | 1.48 | 1.48 |
| Rambewa | 31,604 | 36,325 | 42,355 | 48,207 | 1.27 | 1.29 | 1.29 |
| Sub-total | 72,073 | 83,858 | 99,043 | 113,884 | 1.39 | 1.40 | 1.40 |
| Total | 175,890 | 204,738 | 241,983 | 278,446 | 1.39 | 1.40 | 1.41 |

4.2.4 Demarcation of Design Service Area by Water Supply Mode

In the study area, the population is distributed extensively and the population density is low. About 87.7% of GNDs have a population density of less than 2 persons/ha. In fact, in some sections even along the main roads, there is no housing unit or housing units are very sparsely distributed. Hence, the idea that a water distribution network will be developed along with the road network is obviously not cost-effective.

For this reason, it is necessary to categorize the GNDs into two groups, namely, (1) ones to provide a piped water supply system and (2) the others to deliver water by any other means, for example, the use of water bowsers, which are called “the isolated areas”.

The following four factors with priorities are considered for the identification of isolated areas (GNDs):

- 1st GNDs with an existing water supply system
- 2nd GNDs where the facilities of a proposed water supply system are included
- 3rd GNDs covering a urban centre including its surrounding GNDs

4th GNDs along with main roads designated

From the overlapping of these factors, the following three options are developed:

Option 1 (refer to **Figure 4.2**): All

Existing system + Proposed system + Urban centre + Main roads

Option 2:

Existing system + Proposed system + Urban centre

Option 3:

Existing system + Proposed system

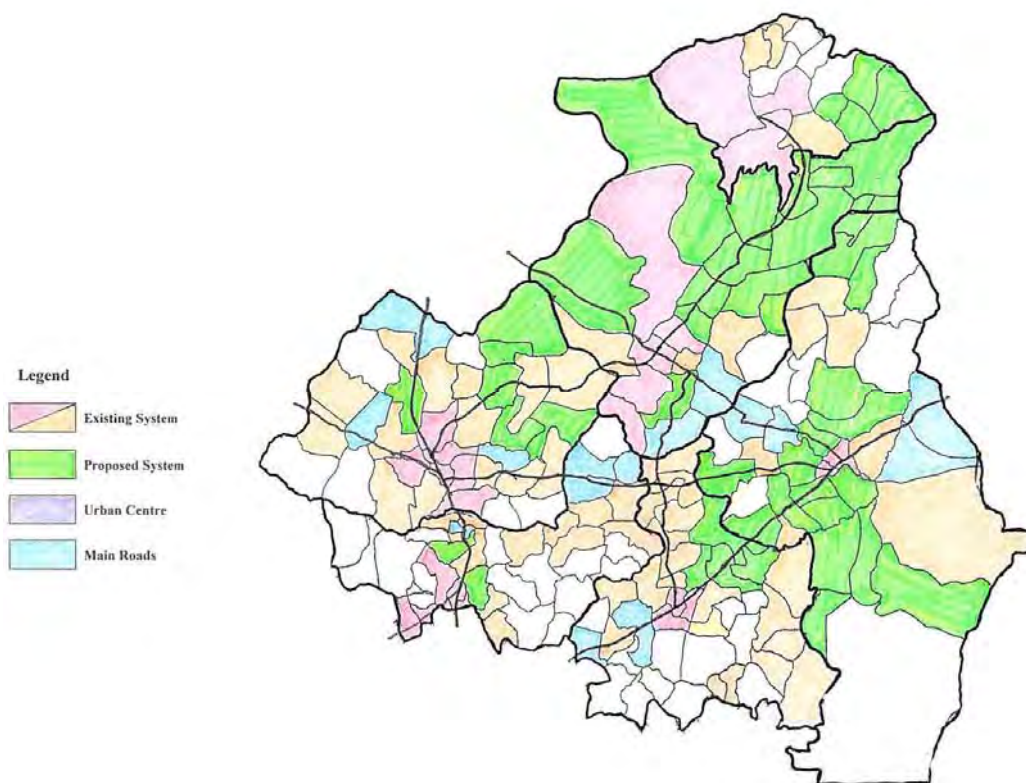

Figure 4.2 Option 1 (No. of Isolated Areas: 47 GNDs)

The GNDs which are excluded from the above options are then identified and termed as “**isolated areas**”, for which a different water supply system from a pipe borne water supply system shall be considered.

Table 4.3 Comparison of Three Options

| Option | Design pop. (pers.) | No. of GNDs as isolated areas | Design water demand on the daily maximum basis (m ³ /day) | |
|----------|------------------------|----------------------------------|--|---------------|
| | | | Mahakanadarawa | Wahalkada |
| 1 | 278,446 | 47 | 17,900 | 27,400 |
| 2&3 | 278,446 | 61 | 16,500 | 25,800 |

In **Table 4.3**, the results of Options 2 and 3 are exactly the same, which means that GNDs as the city centre has been already included in other three factors.

4.2.5 Existing CBOs to Be Excluded from Integration

The following three CBOs, namely 2 CBOs of “No problem in Fluoride Concentration” group and one CBO of “CBO Located Far Away from Proposed Transmission Main Routes” group, are considered to have no necessity to connect to the proposed integrated water supply system

- 20. Diriyamatha CBO (Maha Kumbugollawa [GND S/N 46])
- 47. Tristar CBO (Agunuchchiya [GND S/N 119])
- 26. Al-Naja (Muslim Attaweerawewa [GND S/N 32])

4.2.6 Breakdown of Water Consumption

In a small-scale water supply systems, domestic connections account for about 90% of the total number of connections, but about 75% of water consumption followed by 15% for institutional use and 10% for commercial/industrial use. Based upon the above, non-domestic water use equivalent to 35 % of domestic consumption is added to the per capita water consumption in order to calculate the water demand projection.

4.2.7 Per Capita Domestic Water Consumption

(1) Pipe Borne Water Supply

The existing CBO water supply scheme survey reveals that the average per capita consumption is 66 Lpcd at 46 CBOs during three months from February to April 2012 with no fear of water shortage due to the rainy season. While they are in the range of 85 to 107 Lpcd at five water supply systems under NWSDB located within the study area. Although there is an obvious gap between both per capita consumptions, this is caused by the service area of the NWSDB system covering the urban center and its surrounding area of each DSD where the water consumption is generally higher than the rural area.

Therefore, the per capita water consumption is set at 80 Lpcd for the year of 2012 with an annual increment of 0.5 Lpcd. Accordingly, the per capita water consumption is 86 Lpcd in 2024 and 91 Lpcd in 2034.

(2) Bowser Water Supply

However, for the isolated areas, as discussed later, the per capita water consumption is fixed at 10 Lpcd with no annual increment.

4.2.8 Non-revenue Water (NRW)

The average NRW ratio of NWSDB in 2009 is 53.05% on national average in CMC, compared to 31.07% island wide in the same year, which shows the relatively low value in the developing countries. It is 19.8% especially in RSC (N/C) which is better following 13.8% in RSC(North-Western) and 16.4% in RSC(North).

In the project, the water distribution facilities in the existing water supply schemes will be used for the proposed integrated water supply system as much as possible; however since water transmission and other distribution pipelines will be newly installed, the present NRW level of 20% in Anuradhapura District is assumed to be maintained in the future.

4.2.9 Design Served Population

(1) Pipe Borne Water Supply

At five water supply systems under NWSDB in the study area, the annual increase from the commissioning year to 2001 is 32.7 connections in Padaviya, 10.8 connections in Kebithigollewa, 3.0 connections in Horowpothana, 21.8 connections in Katahagasdigiliya and 16.3 connections in Medawachchiya, although 314 connections was recorded at Kebithigollewa in 2006. Since the people with high expectation for pipe bore water supply would like to connect to a system as soon as possible, the connection works to a system will have a peak during a few years after the completion of a system and thereafter become slow in general.

In the GNDs with an existing system, the population coverage is assumed to grow linearly from the present coverage to 100% in 2034, while in those with no system, the population coverage is assumed to become larger in the later years

(2) Bowser Water Supply

Water supply in the isolated area will be done regularly using water bowsers and arranging the water tank at the convenient locations for water fetching of the people. Population coverage is set at 100% constant.

4.2.10 Design Load Factor to Daily Maximum Water Supply

The monthly fluctuation of five NWSDB water supply systems in the study area varies from

1.18 to 1.23 times the average monthly demand with an average of 1.15. The conversion factor from the average daily demand to the maximum daily demand, which is usually higher than that to the maximum monthly demand, is set at 1.20.

4.2.11 Design Daily Average and Maximum Water Supply and Design Production Capacity

The design fundamentals are summarized in **Table 4.4** as well as **Figure 4.3** Showing the service area of water borne and bowser water supply. Yearly change of design daily average water supply, design daily maximum water supply and design water production is shown in **Table 4.5** for Mahakanadarawa System and Wahalkada System, respectively. Design water production capacity is set so as to have 5% allowance to design daily maximum water supply taking into account the miscellaneous use of water at a water treatment plant.

Table 4.4 Summary of Design Fundamentals

| Design Water Demand | | Application to Facility Design | Unit | Mahakanadarawa System | | | Waghalkada System | | |
|---|--|--------------------------------|-----------------------|-------------------------|---------------------|---------------|-------------------------|---------------------|---------|
| Water Supply Mode | | | | Pipe Borne Water Supply | Bowser Water Supply | Total | Pipe Borne Water Supply | Bowser Water Supply | Total |
| Design Population | | | (prs.) | 92,597 | 19,303 | 111,900 | 144,745 | 16,723 | 161,468 |
| Per Capita Domestic Water Consumption | = $80 + 0.5 \times (2034 - 2012) = 91$ | | (Lpcd) | 91 | 10 | | 91 | 10 | |
| Premium for Non-domestic Water (35%) | = 1.35 | | | 1.35 | 1 | | 1.35 | 1 | |
| NRW Ratio (20%) | = $100 / (100 - 20) = 1.25$ | | | 1.25 | 1 | | 1.25 | 1 | |
| Design Daily Average Water Supply (Dave) | | | (m ³ /day) | 14,219 | 193 | 14,412 | 22,227 | 167 | 22,394 |
| Design Load Factor to Dmax | = 1.2 | | | | | | | | |
| Design Daily Maximum Water Supply (Dmax) | = Dave x 1.20 | Transmission facility | (m ³ /day) | | | 17,294 | | | 26,873 |
| Design Peak Factor | = 2.0 | | | | | | | | |
| Design Hourly Maximum Water Supply (Hmax) | = Dmax x 2.0 | Distribution facility | (m ³ /day) | | | 34,588 | | | 53,746 |
| Design Water Intake | = Dmax x 1.05 | Intake pump station | (m ³ /day) | | | 18,245 | | | 28,217 |
| | | Raw water | | | | 18,200 | | | 28,200 |
| | | transmission facility | | | | ▲ 600 | | | ▲ 600 |
| | | WTP | | | | | | | |
| Water Right | | | (m ³ /day) | | | 18,800 | | 28,800 | |

Table 4.5 Annual Change in Design Daily Average and Maximum Water Supply

Mahakanadarawa System (Encl. Independent CBO)

| | | 2012 ^{*3} | 2014 ^{*3} | 2016 ^{*3} | 2018 | 2020 | 2022 | 2024 | 2026 | 2028 | 2030 | 2032 | 2034 |
|---|--------------------|--------------------|--------------------|--------------------|---------------|---------------|---------------|---------------|----------------|----------------|----------------|----------------|----------------|
| Total Population (persons) | | 83,858 | 86,208 | 88,626 | 91,120 | 93,684 | 96,321 | 99,043 | 101,838 | 104,719 | 107,686 | 110,736 | 113,884 |
| 46 - Maha Kumbukgollewa ^{*1} | Population | 1,430 | 1,473 | 1,518 | 1,564 | 1,611 | 1,660 | 1,710 | 1,761 | 1,815 | 1,870 | 1,926 | 1,984 |
| | Served Population | 286 | 589 | 789 | 860 | 886 | 996 | 1,026 | 1,233 | 1,361 | 1,496 | 1,733 | 1,984 |
| | Water Demand | 39 | 81 | 109 | 120 | 126 | 143 | 149 | 181 | 202 | 225 | 263 | 305 |
| | | | | | | | | | | | | | |
| Target Total Population (persons) | | 82,428 | 84,735 | 87,108 | 89,556 | 92,073 | 94,661 | 97,333 | 100,077 | 102,904 | 105,816 | 108,810 | 111,900 |
| for Pipe Borne WS | Pipe Borne WSS | 62,778 | 64,665 | 66,608 | 68,613 | 70,680 | 72,808 | 75,010 | 82,347 | 84,796 | 87,319 | 89,915 | 92,597 |
| | (Existing) | 46,591 | 48,010 | 49,473 | 50,982 | 52,541 | 54,141 | 55,802 | 57,512 | 59,277 | 61,098 | 62,974 | 64,912 |
| | (New) | 16,187 | 16,655 | 17,135 | 17,631 | 18,139 | 18,667 | 19,208 | 24,835 | 25,519 | 26,221 | 26,941 | 27,685 |
| for Non Pipe Borne WS | Non Pipe Borne WSS | 19,650 | 20,070 | 20,500 | 20,943 | 21,393 | 21,853 | 22,323 | 17,730 | 18,108 | 18,497 | 18,895 | 19,303 |
| Coverage (%) | | 31.4 | 59.4 | 63.0 | 65.2 | 67.5 | 69.7 | 72.0 | 74.8 | 82.1 | 88.4 | 94.7 | 100.0 |
| for Pipe Borne WS | Pipe Borne WSS | 41.2 | 46.8 | 51.6 | 54.6 | 57.7 | 60.7 | 63.7 | 69.4 | 78.2 | 85.9 | 93.6 | 100.0 |
| | (Existing) | 56.0 | 60.0 | 64.0 | 68.0 | 72.0 | 76.0 | 80.0 | 84.0 | 88.0 | 92.0 | 96.0 | 100.0 |
| | (New) | 0.0 | 10.0 | 17.0 | 17.0 | 17.0 | 17.0 | 17.0 | 40.0 | 60.0 | 75.0 | 90.0 | 100.0 |
| for Non Pipe Borne WS | Non Pipe Borne WSS | 100 | 100 | 100 | 100 | 100 | 100 | 100 | 100 | 100 | 100 | 100 | 100 |
| Served Population (persons)^{*2} | | 25,892 | 50,347 | 54,890 | 58,431 | 62,142 | 66,025 | 70,097 | 74,846 | 84,458 | 93,515 | 103,019 | 111,900 |
| for Pipe Borne WS | Pipe Borne WSS | 25,892 | 30,277 | 34,390 | 37,488 | 40,749 | 44,172 | 47,774 | 57,116 | 66,350 | 75,018 | 84,124 | 92,597 |
| | (Existing) | 25,892 | 28,611 | 31,476 | 34,491 | 37,665 | 40,998 | 44,509 | 48,196 | 52,073 | 56,144 | 60,419 | 64,912 |
| | (New) | - | 1,666 | 2,914 | 2,997 | 3,084 | 3,174 | 3,265 | 8,920 | 14,277 | 18,874 | 23,705 | 27,685 |
| for Non Pipe Borne WS | Non Pipe Borne WSS | - | 20,070 | 20,500 | 20,943 | 21,393 | 21,853 | 22,323 | 17,730 | 18,108 | 18,497 | 18,895 | 19,303 |
| Water Demand (Dave: m³/day) | | 3,495 | 4,341 | 4,961 | 5,456 | 5,994 | 6,557 | 7,154 | 8,562 | 10,029 | 11,448 | 12,963 | 14,414 |
| Pipe Borne WS | Pipe Borne WSS | 3,495 | 4,141 | 4,756 | 5,247 | 5,779 | 6,337 | 6,982 | 8,384 | 9,847 | 11,263 | 12,774 | 14,221 |
| | (Existing) | 3,495 | 3,913 | 4,354 | 4,828 | 5,341 | 5,882 | 6,459 | 7,075 | 7,728 | 8,429 | 9,175 | 9,970 |
| | (New) | - | 228 | 402 | 419 | 438 | 455 | 523 | 1,309 | 2,119 | 2,834 | 3,599 | 4,251 |
| Non Pipe Borne WS | Non Pipe Borne WSS | - | 200 | 205 | 209 | 215 | 220 | 172 | 178 | 182 | 185 | 189 | 193 |
| Water Demand for Transmission (Dmax = Dave x 1.20 : m³/day) | | 4,194 | 5,209 | 5,953 | 6,547 | 7,193 | 7,868 | 8,585 | 10,274 | 12,035 | 13,738 | 15,556 | 17,297 |
| Water Demand for Treatment (= Dmax x 1.05 : m³/day) | | 4,400 | 5,500 | 6,300 | 6,900 | 7,600 | 8,300 | 9,000 | 10,800 | 12,600 | 14,400 | 16,300 | 18,200 |

Wahalkada System (Encl. Independent CBOs)

| | | 2012 ^{*3} | 2014 ^{*3} | 2016 ^{*3} | 2018 | 2020 | 2022 | 2024 | 2026 | 2028 | 2030 | 2032 | 2034 |
|---|--------------------|--------------------|--------------------|--------------------|----------------|----------------|----------------|----------------|----------------|----------------|----------------|----------------|----------------|
| Total Population (persons) | | 120,880 | 124,293 | 127,794 | 131,417 | 135,150 | 138,985 | 142,940 | 147,008 | 151,200 | 155,525 | 159,978 | 164,562 |
| 32 - Kurulugama ^{*1} | | 1,354 | 1,379 | 1,403 | 1,429 | 1,455 | 1,481 | 1,508 | 1,535 | 1,563 | 1,591 | 1,620 | 1,649 |
| 119 - Ihala Angunachchiya ^{*1} | | 1,041 | 1,073 | 1,105 | 1,139 | 1,173 | 1,208 | 1,245 | 1,283 | 1,321 | 1,361 | 1,402 | 1,445 |
| Sub-Total | | 2,395 | 2,452 | 2,508 | 2,568 | 2,628 | 2,689 | 2,753 | 2,818 | 2,884 | 2,952 | 3,022 | 3,094 |
| Served Population | | | | | | | | | | | | | |
| 32 - Kurulugama ^{*1} | | 271 | 552 | 730 | 786 | 800 | 889 | 905 | 1,075 | 1,172 | 1,273 | 1,458 | 1,649 |
| 119 - Ihala Angunachchiya ^{*1} | | 208 | 429 | 575 | 626 | 645 | 725 | 747 | 898 | 991 | 1,089 | 1,262 | 1,445 |
| Sub-Total | | 479 | 981 | 1,305 | 1,412 | 1,445 | 1,614 | 1,652 | 1,973 | 2,163 | 2,362 | 2,720 | 3,094 |
| Water Demand | | | | | | | | | | | | | |
| 32 - Kurulugama ^{*1} | | 37 | 75 | 101 | 110 | 113 | 128 | 131 | 158 | 174 | 191 | 221 | 253 |
| 119 - Ihala Angunachchiya ^{*1} | | 28 | 59 | 80 | 88 | 91 | 104 | 108 | 132 | 147 | 164 | 192 | 222 |
| Sub-Total | | 65 | 134 | 181 | 198 | 204 | 232 | 239 | 290 | 321 | 355 | 413 | 475 |
| | | | | | | | | | | | | | |
| Target Total Population (persons) | | 118,485 | 121,841 | 125,286 | 128,849 | 132,522 | 136,296 | 140,187 | 144,190 | 148,316 | 152,573 | 156,956 | 161,468 |
| for Pipe Borne WS | Pipe Borne WSS | 95,911 | 98,775 | 101,715 | 104,766 | 107,907 | 111,145 | 114,485 | 128,836 | 132,633 | 136,549 | 140,587 | 144,745 |
| | (Existing) | 49,985 | 51,530 | 53,117 | 54,762 | 56,462 | 58,216 | 60,026 | 67,997 | 70,064 | 72,193 | 74,394 | 76,664 |
| | (New) | 45,926 | 47,245 | 48,598 | 50,004 | 51,445 | 52,929 | 54,459 | 60,839 | 62,569 | 64,356 | 66,193 | 68,081 |
| for Non Pipe Borne WS | Non Pipe Borne WSS | 22,574 | 23,066 | 23,571 | 24,083 | 24,615 | 25,151 | 25,702 | 15,354 | 15,683 | 16,024 | 16,369 | 16,723 |
| Coverage (%) | | 22.7 | 51.2 | 62.7 | 64.8 | 66.9 | 69.1 | 71.6 | 74.2 | 80.7 | 87.1 | 93.6 | 100.0 |
| for Pipe Borne WS | Pipe Borne WSS | 28.1 | 39.9 | 54.0 | 56.7 | 59.4 | 62.1 | 65.2 | 71.2 | 78.4 | 85.6 | 92.8 | 100.0 |
| | (Existing) | 54.0 | 18.0 | 62.0 | 66.0 | 71.0 | 75.0 | 79.0 | 59.0 | 80.0 | 84.0 | 87.0 | 91.0 |
| | (New) | 0.0 | 20.0 | 45.0 | 46.0 | 47.0 | 48.0 | 50.0 | 60.0 | 70.0 | 80.0 | 90.0 | 100.0 |
| for Non Pipe Borne WS | Non Pipe Borne WSS | 100 | 100 | 100 | 100 | 100 | 100 | 100 | 100 | 100 | 100 | 100 | 100 |
| Served Population (persons)^{*2} | | 26,925 | 62,431 | 78,510 | 83,471 | 88,692 | 94,133 | 100,393 | 107,042 | 119,656 | 132,911 | 146,846 | 161,468 |
| for Pipe Borne WS | Pipe Borne WSS | 26,925 | 39,365 | 54,939 | 59,388 | 64,077 | 68,982 | 74,691 | 91,688 | 103,973 | 116,887 | 130,477 | 144,745 |
| | (Existing) | 26,925 | 29,916 | 33,072 | 36,392 | 39,895 | 43,576 | 47,449 | 51,521 | 55,803 | 60,302 | 65,033 | 70,000 |
| | (New) | - | 9,449 | 21,867 | 22,996 | 24,182 | 25,406 | 27,242 | 40,167 | 48,170 | 56,585 | 65,444 | 74,745 |
| for Non Pipe Borne WS | Non Pipe Borne WSS | - | 23,066 | 23,571 | 24,083 | 24,615 | 25,151 | 25,702 | 15,354 | 15,683 | 16,024 | 16,369 | 16,723 |
| Water Demand (Dave: m³/day) | | 3,636 | 6,611 | 7,843 | 8,556 | 9,336 | 10,147 | 11,098 | 13,616 | 15,599 | 17,719 | 19,979 | 22,392 |
| Pipe Borne WS | Pipe Borne WSS | 3,636 | 5,384 | 7,608 | 8,315 | 9,087 | 9,893 | 10,841 | 13,463 | 15,441 | 17,556 | 19,815 | 22,225 |
| | (Existing) | 3,636 | 4,203 | 4,577 | 5,097 | 5,658 | 6,248 | 6,888 | 7,566 | 8,286 | 9,058 | 9,874 | 10,748 |
| | (New) | - | 2,240 | 3,031 | 3,218 | 3,429 | 3,645 | 3,953 | 5,897 | 7,155 | 8,498 | 9,941 | 11,477 |
| Non Pipe Borne WS | Non Pipe Borne WSS | - | 1,227 | 235 | 241 | 249 | 254 | 257 | 153 | 158 | 163 | 164 | 167 |
| Water Demand for Transmission (Dmax = Dave x 1.20 : m³/day) | | 4,363 | 7,933 | 9,412 | 10,267 | 11,203 | 12,176 | 13,318 | 16,339 | 18,719 | 21,263 | 23,975 | 26,870 |
| Water Demand for Treatment (= Dmax x 1.05 : m³/day) | | 4,600 | 8,300 | 9,900 | 10,800 | 11,800 | 12,800 | 14,000 | 17,200 | 19,700 | 22,300 | 25,200 | 28,200 |

*1 GND excluded from integration

*2 Served population increases as the number of connections increases.

*3 The served population for both pipe borne and non pipe borne water supply before 2018 when the new water supply systems will enter into operation shows the potential figure.

*4 Some GNDs will shift from bowser service area to pipe borne water supply service area in Stage-2 (2025-2034)

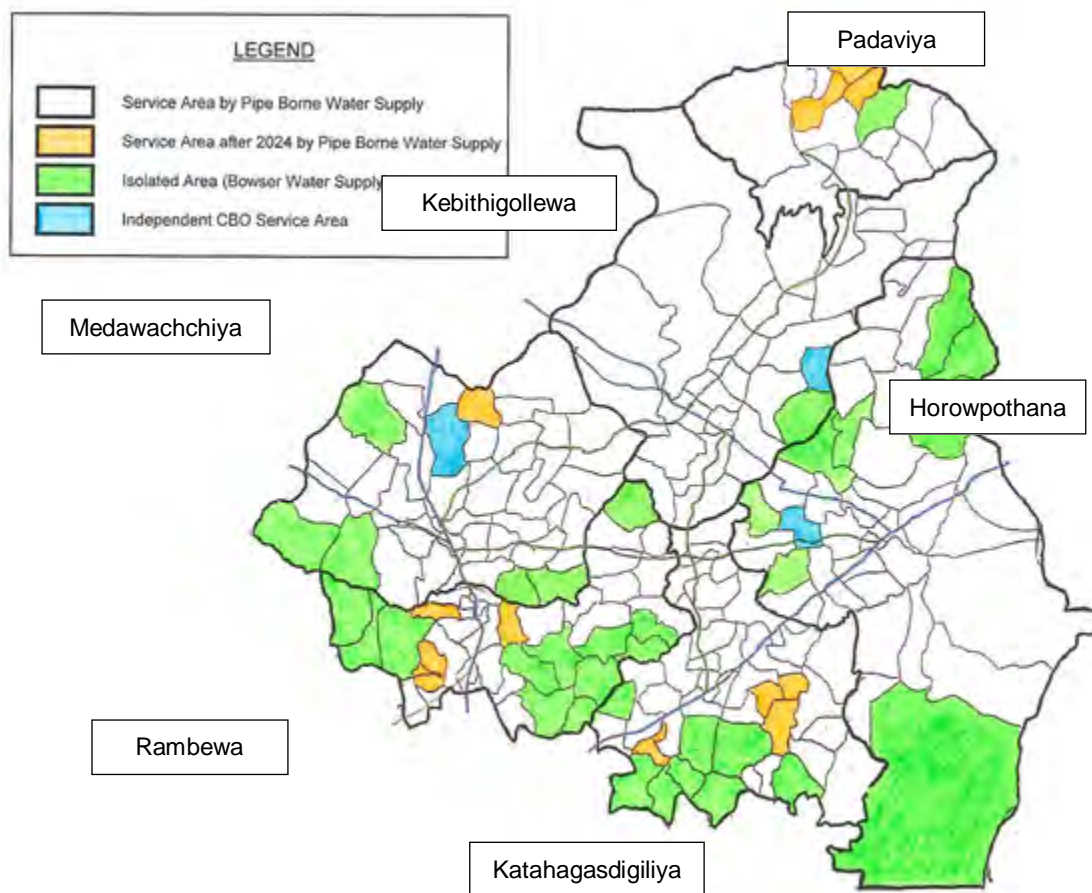

Figure 4.3 Service Area by Pipe Borne and Bowser Water Supply

4.2.12 Design Flow of Water Treatment Plants for Stage Construction

Both water treatment plants for Mahakanadarawa and Wahalkada Systems shall be constructed by stage construction. The reasons for stage construction is described in **Section 5.2.1**.

The design flow for Phase 1 (2024) and Long-term Plan (2034) is shown in **Table 4.6**.

Table 4.6 Design Flow of Water Treatment Plants for Stage Construction

| | Stage-1 (2024) | Stage-2 (2034) |
|----------------------------|----------------|----------------|
| Mahakanadarawa WTP | | |
| Daily Maximum Water Supply | 8,950 m3/day | 17,900 m3/day |
| Production Capacity | 9,400 m3/day | 18,800 m3/day |
| Wahalkada WTP | | |
| Daily Maximum Water Supply | 13,700m3/day | 27,400 m3/day |
| Production Capacity | 14,400 m3/day | 28,800 m3/day |

4.3 Water Availability

4.3.1 Water source

As mentioned in **Chapter 2**, there is a high risk of fluoride concentration in the groundwater of the Study Area, therefore the source for drinking water needs to be shifted to the surface water. This section will discuss availability of the water source focused only on surface water.

In the Study Area of Anuradhapura District, there are available only seasonal rivers, that flows during the rainy season, therefore, the surface water source for drinking water is expected only from water reservoirs, Mahakanadarawa wewa and Wahalkada wewa.

4.3.2 Water Quality

(1) Purpose

To evaluate the water resources for a safe drinking water supply, it is very important to investigate essential water quality parameters in the water resources. The analysis of water quality can provide chemical and biological characteristics of the water as well as basic information of the safety of the water. Attention should be paid particularly on some substances that will have a health impact by drinking. In this subchapter, at first the general characteristics of Mahakandawara wewa, Wahalkada wewa and Yan Oya irrigation water are mentioned. The results of the general water quality analysis done in the study are evaluated by comparison with the Sri Lanka drinking water standard 614:1983.

A series of quality control measures, which are operational techniques and activities that are used to fulfill requirements of JICA Study Team for quality tests, were also conducted. The quality control program conducted consists of an internal quality control and an external quality control. Additionally, data comparison between the NWSDB lab in Anuradhapura and the SGS's laboratory in Colombo, the subcontractor under the Study Team, was also performed as part of capacity development of the NWSDB lab.

(2) Results

(a) General characteristics of targeted water sources

The results of the laboratory chemical and microbiological analysis for the targeted water sources are shown in **Table 4.7**. From these data, some general characteristics are found as mentioned below.

Table 4.7 Results of Laboratory Chemical and Microbiological Analysis for Proposed Water Sources

| Water source | Sampling station | Date | Odor | Colour | Turbidity | Taste | pH | EC | Chloride | Free residual Cl | Free ammonia | Alkalinity | Abrasive silica | Nitrite | Nitrate | Fluoride | Phosphate | Total residual | Hardness | Iron | Sulphate | Anionic detergent | Phenol compound | COD | O&G | Ca | Mg | Cu | Mn | Zn | Al | Total plate count | E. coli | Total coliform | Chlorophyll a | | | | | | | | | |
|---------------------|------------------|----------|------------|--------|-----------|---------|-------|------|----------|------------------|--------------|------------|-----------------|---------|---------|----------|-----------|----------------|----------|------|----------|-------------------|-----------------|------|------|------|-------|-------|-------|-------|---------------------|---------------------|---------------------|----------------|---------------|--------|-------|-------|------|------|------|------|------|-----|
| | | | Hazen Unit | NTU | | | µS/cm | mg/L | mg/L | mg/L | mg/L | mg/L | mg/L | mg/L | mg/L | mg/L | mg/L | mg/L | mg/L | mg/L | mg/L | mg/L | mg/L | mg/L | mg/L | mg/L | mg/L | mg/L | mg/L | mg/L | CFU/mL | MPN/100mL | MPN/100mL | mg/L | | | | | | | | | | |
| Mahakanadarawa Wewa | inlet | 11/7/20 | Object | 5 | 4 | Object | 6.7 | 344 | 51 | <0.04 | <0.04 | 86 | <0.04 | <0.01 | 0.26 | 0.09 | <0.05 | 166 | 96 | 0.1 | 2 | <0.1 | <0.002 | 14 | <1 | 16 | 14 | <0.02 | <0.03 | <0.01 | <0.08 | 3.2x10 ⁴ | 13 | 79 | | | | | | | | | | |
| | outlet | 11/7/20 | Object | 5 | 4 | Object | 6.5 | 343 | 51 | <0.04 | <0.04 | 88 | <0.04 | <0.01 | 0.26 | 0.09 | <0.05 | 164 | 92 | 0.1 | 2 | <0.1 | <0.002 | 17 | <1 | 16 | 13 | <0.02 | <0.03 | <0.01 | <0.08 | 2.0x10 ⁴ | 5 | 8 | | | | | | | | | | |
| | Deepest | 11/7/21 | Object | 5 | 3.8 | Object | 6.7 | 343 | 51 | <0.04 | <0.04 | 87 | <0.04 | <0.01 | 0.07 | 0.11 | <0.05 | 176 | 98 | 0.1 | 2 | <0.1 | <0.002 | 20 | <1 | 16 | 14 | <0.02 | <0.03 | <0.01 | <0.08 | 1.7x10 ⁴ | ND | 23 | | | | | | | | | | |
| | inlet | 12/01/11 | Unobjct | 7.5 | 3.7 | Unobjct | 7.8 | 348 | 52 | <0.04 | <0.04 | 93 | 0.05 | <0.01 | 0.09 | 0.10 | 0.2 | 132 | 95 | 0.2 | 1.4 | <0.1 | <0.002 | <5 | <1 | 18 | 12 | <0.02 | <0.03 | <0.01 | <0.08 | 34 | ND | 8 | | | | | | | | | | |
| | outlet | 12/01/21 | Unobjct | 10 | 3.8 | Unobjct | 7.9 | 355 | 53 | <0.04 | 0.22 | 94 | 0.38 | <0.01 | 0.07 | 0.12 | 0.16 | 172 | 96 | 0.1 | 1 | <0.1 | <0.002 | <5 | <1 | 18 | 13 | <0.02 | <0.03 | <0.01 | <0.08 | 64 | ND | 9 | | | | | | | | | | |
| | Deepest | 12/01/21 | Unobjct | 7.5 | 2.9 | Unobjct | 7.7 | 370 | 52 | <0.04 | 0.2 | 97 | 0.28 | <0.01 | 0.07 | 0.14 | 0.23 | 170 | 96 | 0.3 | 1.4 | <0.1 | <0.002 | <5 | <1 | 17 | 13 | <0.02 | <0.03 | <0.01 | <0.08 | 40 | ND | 8 | | | | | | | | | | |
| | inlet | 12/02/14 | Unobjct | 5 | 2.7 | Unobjct | 7.6 | 411 | 61 | 0.14 | 0.04 | 107 | 0.36 | <0.01 | <0.05 | 0.17 | 0.06 | 228 | 100 | 0.2 | 1.4 | <0.1 | <0.002 | 21 | <1 | 18 | 9.0 | <0.02 | <0.03 | <0.01 | <0.08 | 4.0x10 ⁴ | 13 | 130 | | | | | | | | | | |
| | outlet | 12/02/14 | Unobjct | 5 | 3.7 | Unobjct | 7.7 | 415 | 54 | <0.04 | 0.22 | 107 | 0.33 | <0.01 | <0.05 | 0.33 | 0.09 | 235 | 105 | 0.2 | 3.4 | <0.1 | <0.002 | 16 | <1 | 30 | 9.7 | <0.02 | <0.03 | <0.01 | <0.08 | 2.0x10 ⁴ | 13 | 79 | | | | | | | | | | |
| | Deepest | 12/02/14 | Unobjct | 5 | 6.8 | Unobjct | 7.7 | 417 | 60 | 0.1 | 0.15 | 96 | 0.22 | <0.01 | <0.05 | 0.30 | 0.06 | 234 | 109 | 0.3 | 1.5 | <0.1 | <0.002 | 20 | <1 | 22 | 9.2 | <0.02 | <0.03 | <0.01 | <0.08 | 9.5x10 ⁴ | 2 | 79 | | | | | | | | | | |
| | inlet | 12/03/19 | Unobjct | ND | 3.8 | Unobjct | 7.6 | 471 | 76 | <0.04 | 0.05 | 112 | 0.27 | 0.05 | 0.41 | 0.18 | <0.05 | 279 | 94 | 0.48 | 4 | <0.1 | <0.002 | 42 | <1 | 21 | 10.0 | <0.02 | <0.03 | <0.01 | <0.08 | 3.0x10 ⁴ | ND | 2 | | | | | | | | | | |
| | outlet | 12/03/19 | Unobjct | ND | 3 | Unobjct | 7.9 | 462 | 79 | <0.04 | 0.07 | 120 | 0.28 | 0.01 | 0.38 | 0.17 | <0.05 | 250 | 100 | <0.1 | 4.2 | <0.1 | <0.002 | 14 | <1 | 22 | 11.0 | <0.02 | <0.03 | <0.01 | <0.08 | 5.8x10 ⁴ | ND | 240 | | | | | | | | | | |
| | Deepest | 12/03/19 | Unobjct | ND | 3 | Unobjct | 7.8 | 470 | 79 | <0.04 | 0.05 | 95 | 0.23 | <0.01 | 0.23 | 0.17 | <0.05 | 263 | 96 | <0.1 | 5.4 | <0.1 | <0.002 | 10 | <1 | 22 | 10 | <0.02 | <0.03 | <0.01 | <0.08 | 2.3x10 ⁴ | ND | 5 | | | | | | | | | | |
| | inlet | 12/05/02 | Unobjct | 5 | 5.1 | Unobjct | 8.2 | 464 | 74 | <0.04 | 0.33 | 138 | 0.91 | <0.01 | 0.12 | 0.43 | 0.1 | 277 | 148 | 0.2 | 2.1 | <0.1 | <0.002 | 14 | <1 | 24 | 22.0 | <0.02 | 0.11 | 0.04 | 0.1 | 2.8x10 ⁴ | ND | 33 | | | | | | | | | | |
| | outlet | 12/05/02 | Unobjct | 5 | 4.3 | Unobjct | 7.4 | 223 | 80 | <0.04 | 0.3 | 139 | 0.82 | <0.01 | 0.21 | 0.38 | 0.06 | 208 | 144 | <0.1 | 1.5 | <0.1 | <0.002 | 20 | <1 | 24 | 21.0 | <0.02 | 0.35 | 0.16 | 0.09 | <0.08 | 2.8x10 ⁴ | 8 | 49 | | | | | | | | | |
| | Deepest | 12/05/02 | Unobjct | 5 | 3.4 | Unobjct | 7.7 | 251 | 79 | <0.04 | 0.38 | 134 | 0.84 | <0.01 | 0.18 | 0.37 | <0.05 | 264 | 144 | 0.1 | 1.8 | <0.1 | <0.002 | 22 | <1 | 24 | 21 | <0.02 | 0.12 | 0.02 | <0.08 | 1.6x10 ⁴ | ND | 13 | | | | | | | | | | |
| | IC Conn. S. | 12/05/22 | Unobjct | 5 | 6.8 | Unobjct | 8.2 | 512 | 86 | <0.04 | 0.30 | 130 | 0.49 | <0.01 | 0.16 | 0.34 | 0.14 | 339 | 142 | 0.2 | 3.8 | | | | | | | | | | | | | 23 | 23 | 0.0022 | | | | | | | | |
| | IC Conn. B. | 12/05/22 | Unobjct | 5 | 7.6 | Object | 8 | 512 | 85 | 0.16 | 0.26 | 126 | 0.66 | <0.01 | 0.15 | 0.38 | 0.12 | 332 | 144 | 0.3 | 2 | | | | | | | | | | | | | | 13 | 23 | 0.074 | | | | | | | |
| | Deepest | 12/05/22 | Unobjct | 5 | 8.8 | Object | 7.4 | 509 | 86 | <0.04 | 0.34 | 134 | 0.57 | <0.01 | 0.3 | 0.37 | 0.1 | 361 | 146 | 0.1 | 1.6 | | | | | | | | | | | | | | | 2 | 33 | 0.091 | | | | | | |
| | IC Conn. S. | 12/06/28 | Unobjct | 7.5 | 16 | Object | 8.6 | 576 | 95 | <0.04 | 0.10 | 110 | 0.14 | <0.01 | 0.19 | 0.43 | 0.54 | 375 | 151 | 0.6 | 12 | | | | | | | | | | | | | | | ND | 25 | 0.2 | | | | | | |
| | IC Conn. B. | 12/06/28 | Unobjct | 10 | 16 | Object | 8.5 | 580 | 77 | 0.02 | 0.10 | 112 | 0.02 | 0.02 | 0.45 | 0.38 | 0.8 | 289 | 119 | 0.4 | 10 | | | | | | | | | | | | | | | | 2 | 26 | 0.2 | | | | | |
| | Deepest | 12/06/28 | Unobjct | 10 | 16 | Object | 8.6 | 586 | 93 | 0.10 | <0.04 | 143 | 0.16 | <0.01 | 0.21 | 0.45 | 0.82 | 369 | 159 | 0.3 | 9.8 | | | | | | | | | | | | | | | | | 3 | 26 | 0.18 | | | | |
| | IC Conn. S. | 12/07/26 | Unobjct | 10 | 12 | Object | 8.5 | 620 | 105 | <0.01 | 0.152 | 152 | 0.26 | <0.01 | 0.54 | 0.52 | 0.21 | 400 | 161 | 0.6 | 1.8 | | | | | | | | | | | | | | | | | 8 | 1600 | 0.21 | | | | |
| | IC Conn. B. | 12/07/26 | Unobjct | 10 | 11 | Object | 8.2 | 624 | 103 | <0.02 | 0.70 | 120 | 0.22 | <0.01 | 0.13 | 0.51 | <0.21 | 404 | 163 | <0.1 | 1.9 | | | | | | | | | | | | | | | | | | 6 | 80 | 0.28 | | | |
| | Deepest | 12/07/26 | Unobjct | 10 | 13 | Object | 8.4 | 625 | 104 | 0.02 | 0.94 | 130 | 0.33 | <0.01 | 0.56 | 0.51 | <0.21 | 399 | 159 | 0.8 | 2.4 | | | | | | | | | | | | | | | | | | 7 | 70 | 0.23 | | | |
| | IC Conn. S. | 12/09/26 | Unobjct | 10 | 18 | Object | 8.4 | 736 | 142 | 0.53 | 1.62 | 2.7 | <0.01 | 0.3 | 0.45 | 0.32 | 456 | 173 | 0.6 | 2.3 | | | | | | | | | | | | | | | | | | | 8 | 23 | 0.54 | | | |
| | IC Conn. B. | 12/09/26 | Unobjct | 10 | 18 | Object | 8.3 | 746 | 140 | 0.45 | 1.62 | 2.3 | <0.01 | 0.57 | 0.46 | 0.3 | 457 | 179 | 0.6 | 2.1 | | | | | | | | | | | | | | | | | | | | 14 | 35 | 0.59 | | |
| | Deepest | 12/09/26 | Unobjct | 10 | 20 | Object | 8.7 | 738 | 144 | 0.35 | 1.64 | 2.5 | <0.01 | 0.27 | 0.47 | 0.31 | 480 | 173 | 0.6 | 2.2 | | | | | | | | | | | | | | | | | | | | | 2 | 8 | 0.5 | |
| | IC Conn. S. | 12/10/16 | Unobjct | 10 | 16 | Object | 7.9 | 711 | 131 | 0.12 | 1.55 | 1.6 | <0.01 | 0.27 | 0.47 | 0.21 | 420 | 198 | 0.4 | 8.9 | | | | | | | | | | | | | | | | | | | | | 80 | 1600 | 0.34 | |
| | IC Conn. B. | 12/10/16 | Unobjct | 10 | 27 | Object | 7.3 | 719 | 133 | 0.13 | 1.52 | 1.8 | <0.01 | 0.24 | 0.46 | 0.25 | 436 | 186 | 1 | 12 | | | | | | | | | | | | | | | | | | | | | 45 | 1600 | 0.38 | |
| | Deepest | 12/10/16 | Unobjct | 10 | 20 | Object | 7.6 | 685 | 123 | 0.14 | 1.84 | 1.8 | <0.01 | 0.21 | 0.44 | 0.22 | 369 | 182 | 0.8 | 11 | | | | | | | | | | | | | | | | | | | | | | | 35 | 250 |
| inlet | 11/7/21 | Object | ND | 4.9 | Object | 7.9 | 204 | 11 | <0.04 | <0.04 | 85 | <0.04 | <0.01 | 0.11 | 0.06 | <0.05 | 84 | 68 | 0.1 | 2 | <0.1 | <0.002 | 13 | <1 | 16 | 7 | <0.02 | <0.02 | <0.01 | <0.08 | 46 | ND | ND | | | | | | | | | | | |
| outlet | 11/7/21 | Object | ND | 3.8 | Object | 6.9 | 188 | 12 | <0.04 | <0.04 | 85 | <0.04 | <0.01 | 0.09 | 0.06 | <0.05 | 82 | 71 | 0.2 | 3 | <0.1 | 0.0002 | 12 | <1 | 16 | 8 | <0.02 | <0.03 | <0.01 | <0.08 | 79 | ND | 8 | | | | | | | | | | | |
| Deepest | 11/7/21 | Object | 2.5 | 2.7 | Object | 7.2 | 202 | 12 | <0.04 | <0.04 | 85 | <0.04 | <0.01 | 0.09 | 0.06 | <0.05 | 90 | 78 | 0.2 | 2 | <0.1 | 0.0002 | 15 | <1 | 16 | 9 | <0.02 | <0.03 | <0.01 | <0.08 | 58 | ND | 23 | | | | | | | | | | | |
| inlet | 12/01/12 | Unobjct | 10 | 4.7 | Unobjct | 8.7 | 200 | 12 | <0.04 | 0.28 | 90 | 0.42 | <0.01 | 0.1 | 0.07 | 0.14 | 86 | 70 | 0.2 | 1.4 | <0.1 | <0.002 | <5 | <1 | 15 | 8 | <0.02 | <0.03 | <0.01 | <0.08 | 1.0x10 ⁴ | 5 | 27 | | | | | | | | | | | |
| outlet | 12/01/12 | Unobjct | 10 | 4.6 | Unobjct | 8.5 | 203 | 12 | <0.04 | 0.35 | 93 | 0.63 | <0.01 | 0.08 | 0.07 | 0.15 | 70 | 68 | 0.2 | 1.5 | <0.1 | <0.002 | <5 | & | | | | | | | | | | | | | | | | | | | | |

Firstly, it can be said that eutrophication of the lakes has progressed at both the target water sources. Eutrophication occurs by nutrition increases such as nitrogen and phosphorous, then phytoplankton in the water increases due to the nutrition increases. High concentration of albuminoid ammonia and free ammonia in the water quality results show this phenomenon. In addition, both the target water sources have a greenish color and the water quality results show the high color values and chlorophyll a. It can be said that this greenish color caused by phytoplankton is increasing in the water. High concentration of albuminoid ammonia and COD seems to reflect an increase in the content of organic matter in lake water by phytoplankton growth. Both the target water sources show high value, around 8 of pH, and it seems to be due to the carbonate consumption and hydroxyl ions release in water by the growth of phytoplankton. Such eutrophication seems not be caused by human sewage as the population surrounding both water sources is not high. One possibility is overfertilization of paddy fields and other fields surrounding the water sources.

Seasonal changes of water quality due to rainy and dry seasons also occurs. Recharge water of targeted water sources in the dry season is reduced, and the existing water in targeted water sources are concentrated by evaporation so the contents are increased. This trend is remarkable in Mahakandawara wewa though Wahalkada shows less of a trend of this.

In Sri Lanka, high concentrations of fluoride are found in groundwater in many areas and the project area is also known as a higher concentration area of fluoride. Therefore, continuous water quality monitoring of the said parameter is essential. As fluoride is a substance derived from minerals, both groundwater and surface water contain fluoride if it has come into contact with the mineral. As for fluoride in targeted water sources, the same as EC, Cl and Hardness, the concentrations are lower in the rainy season and becomes higher in the dry season. The trends are shown as follows.

(b) General characteristics of Yan Oya reservoir water

Yan Oya Reservoir to be newly constructed will has a plan to supply water to the part of an irrigation area for Wahalkada Scheme and improve the water use condition of Wahalkada Wewa.

Firstly, it can be said that Yan Oya water shows a groundwater characteristics even though it is a surface water. Higher concentration of EC, chloride, hardness, fluoride, iron, sulphate, magnesium and aluminum compared with Mahakandawara and Wahalkada wewa were found. Some comparison figures are shown below.

Unlike the other two water sources, Yan Oya shows a high fluoride content. As mentioned, one of Yan Oya water source seems to be groundwater, and that groundwater may have a high concentration of fluoride. Compared with other proposed water sources, fluoride

concentrations of Yan Oya water have exceeded 0.6 mg/L for a period of May to September, which is the desirable level of Sri Lankan drinking water standard.

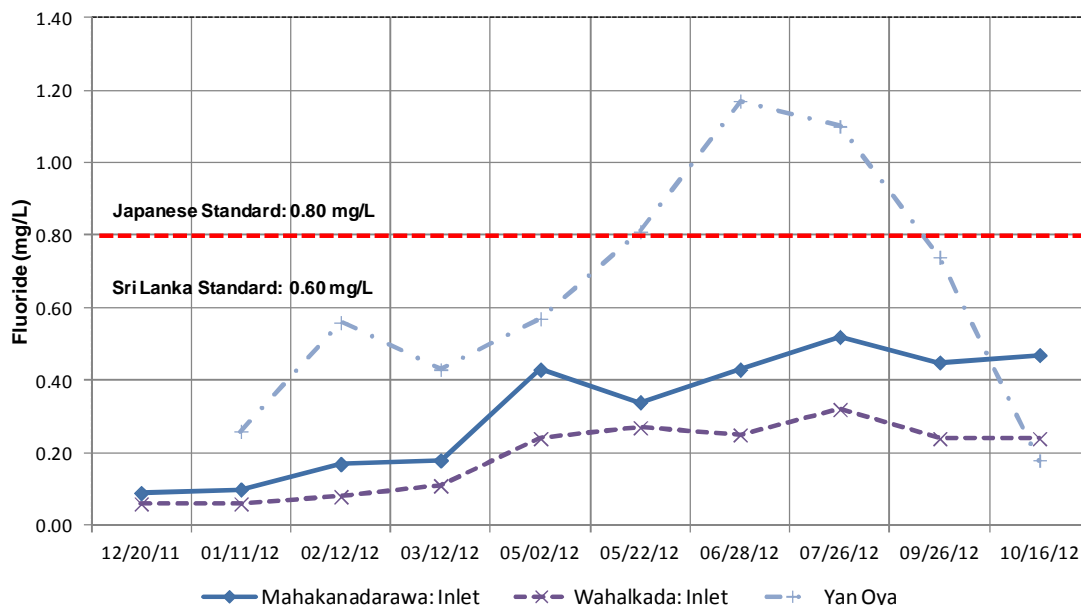

Figure 4.4 Water Quality (Fluoride)

As shown in **Figure 4.4**, from May to June in the dry season, the fluoride concentrations have increased in any of three water source candidates, especially in Yan Oya of which fluoride has recorded at 1.2 mg/L in June and which cannot be used for drinking water supply without any treatment for fluoride removal. Those in Mahakanadarawa Wewa and Wahalkada Wewa have also increased to 0.52 mg/L and 0.38 mg/L, respectively. Some of other parameters have exceeded the Sri Lankan drinking water standards but they were within the level to be treated in the course of water treatment.

4.3.3 Present Operation of Irrigation Reservoir

(1) Entity of the operation and management

Operation and management of the irrigation tanks is under the responsibility of the Irrigation Department, which is an “A class” Governmental Department. The Department was formed 110 years ago and is subject to the control and direction of the Ministry of Irrigation and Water Management, which is overall in charge of Irrigation. The Irrigation Department implements the policies and programs of the Ministry, as the principal organization for the regulation and control of irrigation waters.

The Regional Director of Irrigation, Anuradhapura has responsibility for the Mahakanadarawa and Wahalkada tanks. Four Irrigation Engineer’s Offices, which are located in Radviya, Anuradhapura, Rajanganay and Hurulu Wewa, and one Regional Engineer Office, which is

located in Nachchaduwa for are responsible for management of irrigation schemes. Operation and management of Mahakanadarawa tank is controlled by the Irrigation Engineer's Office in Mahakanadarawa, and Wahalkada tank by the Office in Radviya.

(2) Condition of Irrigation and Water Use

The water uses of the above tanks are irrigation and fisheries. Irrigation water is mainly used for paddy fields and partly used for other upland crops under an annual irrigation program. The general condition of the irrigation scheme and basic factors of the irrigation program in this region are shown in **Table 4.8**.

Table 4.8 General Condition of the irrigation

| Item | Outline |
|---------------------------|--|
| Irrigation period in Maha | Nov. – March |
| Irrigation period in Yala | May – September |
| Major Crops | Rice (Paddy field) |
| Irrigation Area | <p>Mahakanadarawa Scheme :</p> <p>Max. Irrigable area: 6,000Ac (2,420ha)</p> <p>Irrigable area by FSL: 3,600Ac (1,460ha)</p> <p>(around 50% of 3,600 Ac is available in Yala season)</p> <p>Wahalkada Scheme :</p> <p>Max. Irrigable area: 2,257Ac (910ha)</p> <p>Irrigable area by FSL: 2,000Ac (810ha)</p> |

The irrigation water requirement is approximately calculated based on the above and the following conditions:

- Potential Evapotranspiration:
 - Mahakanadarawa Scheme: Data at Mahailuppallama Station
 - Wahalkada Scheme: Data at Vavniya Station
- Cropping factor: 0.90~1.15, depending on the growing stage
- Rainfall:
 - Mahakanadarawa Scheme: Data at Anuradhapura Station with efficiency of 80%
 - Wahalkada Scheme: Data at Wahalkada Station with efficiency of 80%
- Irrigation Period: Yala in May-August, Maha in Nov.-March
- Irrigation Area:
 - Mahakanadarawa Scheme: 1460 ha
 - Wahalkada Scheme: 810 ha
- Efficiency: 40% (case of no lining canal)

(3) Operation Method for Irrigation Water Use

Mahakanadarawa scheme has two intake wells for irrigation and the Wahalkada Scheme has one. The irrigation water requirement varies throughout the year depending on factors such as storage volume, market price, availability of man power and machinery. Representatives of farmer's organization and the Irrigation Department discuss and determine the water volume and period for irrigation. Normally, there is a period of between 10 and 14 days for preparation period, then water is supplied for 5 days, followed by a period of 5 days with no water, with the cycle continuously repeating. Water is controlled to keep a minimum water depth of 25 mm in the paddy field.

Table 4.9 shows the annual irrigation water use in 2009-2011. In the case of the Mahakanadarawa scheme, water use varied from 19.41 to 42.42 MCM, with the amount partly being dependent on the quantity of water stored early in the season. On the other hand, in the case of the Wahalkada scheme, the variation in irrigation water use is not as big as in the Mahakanadarawa scheme, ranging from about 12 to 16 MCM, with the storage volume early in the season varying.

Table 4.9 Irrigation Water Used in 2009-2011

| | Mahakanadarawa tank | | Wahalkada Tank | |
|----------------------------------|-------------------------|-------------------------------|-------------------------|-------------------------------|
| | Storage in Jan. 1 (MCM) | Irrigation Water Supply (MCM) | Storage in Jan. 1 (MCM) | Irrigation Water Supply (MCM) |
| Gross Calc. for Average Rainfall | | 22.2 | | 10.9 |
| 2009 | 44.78 | No data | 17.45 | 12.13 |
| 2010 | 22.50 | 19.41 | 21.50 | 16.13 |
| 2011 | 44.78 | 42.42 | 26.73 | 15.95 |

(4) Storage Variation of Mahakanadarawa and Wahalkada Wewa

Table 4.10 shows general details of the above reservoirs.

Table 4.10 General Data of Mahakanadarawa and Wahalkada Tank

| Item | Mahakanadarawa Wewa | Wahalkada Wewa |
|-------------------------|--|--------------------------------------|
| Full Supply Level (FSL) | 311 ft | 155 ft |
| Gross Storage for FSL | 36,250 Acft | 43,000 Acft |
| Dead Storage | 2,000 Acft | 2,025 Acft |
| High Flood Level | 315 ft | 156 ft |
| Top level | 320 ft | 162 ft |
| Top Width | 18 ft | 20 ft |
| Max. Height | 19 ft | 40 ft |
| Intake | 2 places RB: Intake well, sluice gate LB: Intake well, sluice gate | 1 places Intake well, sluice gate |
| Canal | 2lines, only LB Canal in dry season | 1 line |

The water level and storage data of the reservoirs was collected from the Irrigation Regional Office in Anuradhapura.

The storage volume was about 18,000 Acft (22.14 MCM) in January 2005, and only 15,000 Acft (18.5 MCM) were used for irrigation, corresponding to 167 Acft (0.205 MCM). Basically, the Mahakanadarawa scheme has the potential to irrigate an area of 6,000 Ac (2,420ha). However, because of the limitation of water, 3,000 Ac is normally irrigated even under FSL storage conditions. The irrigation area in the Yala season is 1,800 Ac (730ha), 50% of the area under FSL storage conditions.

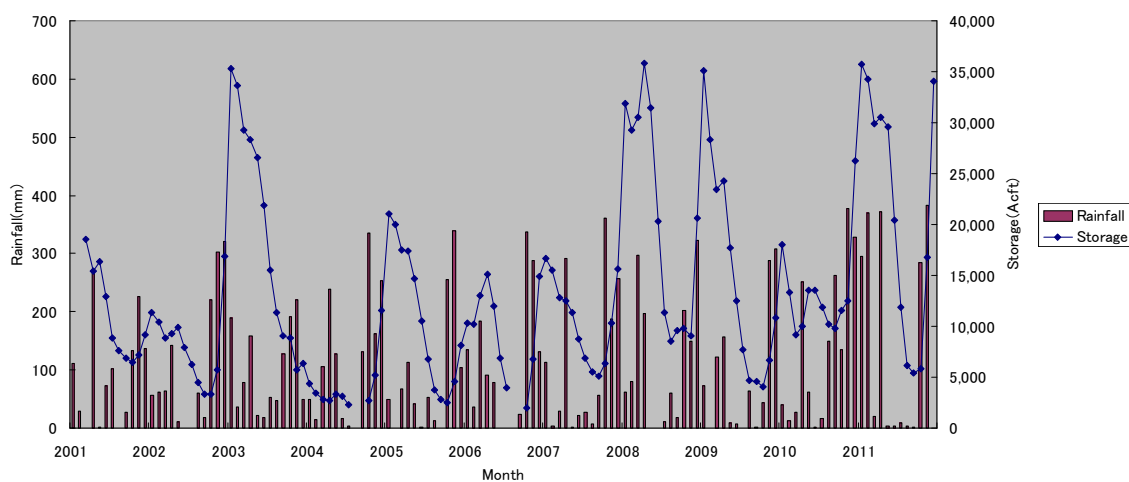

Figure 4.5 Monthly Rainfall and Storage in Mahakanadarawa Tank

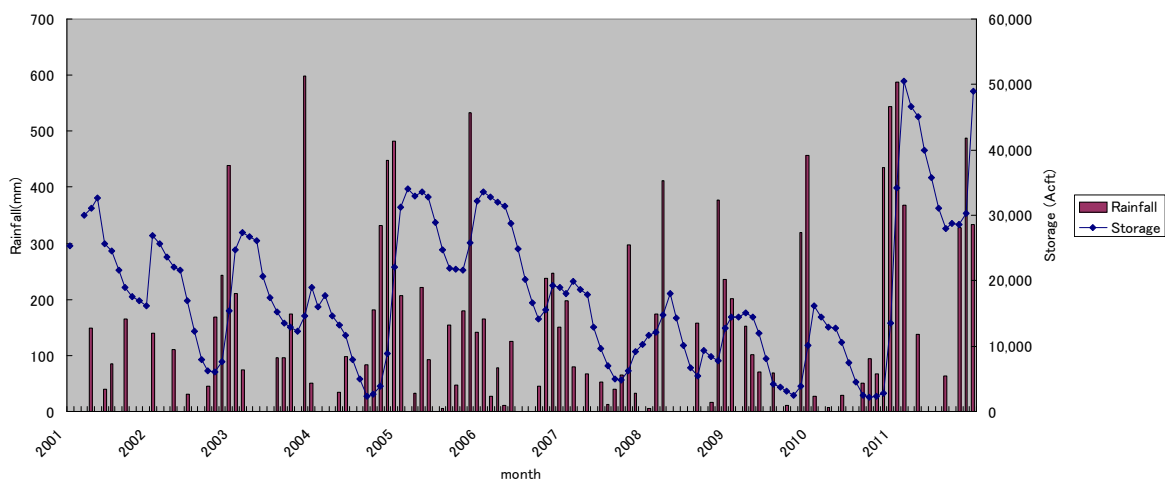

Figure 4.6 Monthly Rainfall and Storage in Wahalkada Tank

4.3.4 Water Availability from Irrigation Reservoir

The objective of this analysis is to evaluate the availability of water for drinking use from Mahakanadarawa and Wahalkada Wewa. The storage amount in the reservoirs varies depending upon rainfall and irrigation use, which itself is dependent on many factors such as agriculture marketing aspect, use of machinery, input of man power, etc.

Because of the limited study period, no direct measurement of inflow to and outflow from the reservoirs or detailed model simulation was carried out. Basically, collected data and information from the Meteorological Department and Regional Irrigation Department were used for the evaluation.

(1) Water Balance of the reservoirs

An estimate of the gross annual water balance of reservoirs has been made. Factors in the water balance are inflow from the catchment area, rainfall, evaporation, seepage and irrigation use, as shown in **Figure 4.7**.

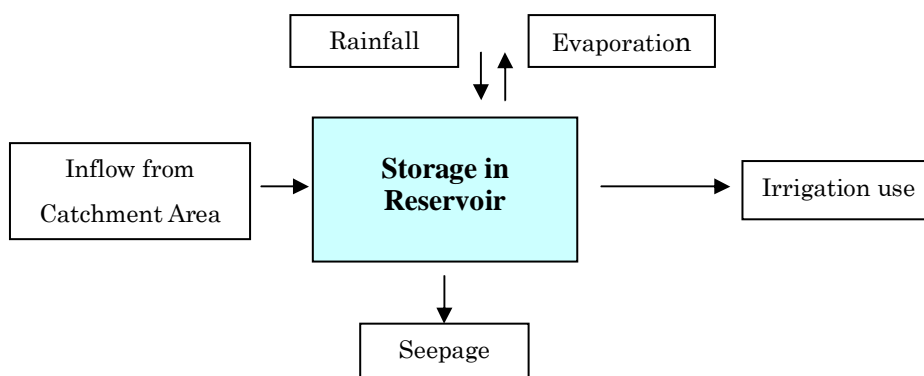

Figure 4.7 Image of Water Balance

1) Rainfall

Average annual rainfall in the Study Area is used as follows.

| | |
|------------------------|----------|
| Anuradhapura Station : | 1,246 mm |
| Wahalkada Station : | 1,441 mm |

2) Estimation of run-off from catchment area

Gross run-off coefficient from the catchment area to the reservoir is analyzed based on the increase in reservoir's storage and monthly rainfall from October to January at the start of the rainy season.

According to the intake data of the Irrigation Department, irrigation water is used even in the rainy season; therefore the calculated coefficient is considered on the safe side in order to

maintain storage.

Values of runoff varies between 3%~12% in Mahakanadarawa and between 5%~26% in Wahalkada. The catchment areas include many small tanks and paddy fields and as such the initial and small amounts of rainfall can be stored in these places. Furthermore, outflow to the reservoir is only from the surrounding area and after filling of the paddy fields and small tanks, i.e. the variation in run off is due to the volume and continuity of rainfall.

3) Gross Estimation of Water Balance

The gross Water Balance is estimated by assuming runoff coefficients. Based on the mentioned calculation, the runoff coefficient from the whole catchment area is estimated at 20% in Wahalkada Wewa, and 8% in Mahakanadarawa Wewa. Seepage is neglected because this is a relatively small amount, compared to the total storage volume.

Table 4.11 Gross Estimation of Water Balance

| | Mahakanadarawa | Wahalkada |
|--|----------------|-----------|
| Average Rainfall (mm/yr) | 1,240 | 1,440 |
| Catchment Area(km ²) | 334 | 83 |
| Runoff Coefficient (%) | 8 | 20 |
| Water Area of Reservoir (km ²) | 9 | 2.1 |
| Annual inflow to the Reservoir (MCM) | 33.13 | 23.90 |
| Volume by rainfall (MCM) | 11.16 | 2.96 |
| Evaporation from water surface (MCM) | 11.93 | 2.60 |
| Seepage (MCM) | — | — |
| Average Annual Storage (MCM) | 32.36 | 23.77 |
| Average Annual Storage (Acft) | 26,244 | 19,278 |

(2) Water availability for the Project

As a conclusion, water availability in Mahakanadarawa Wewa and Whahalkada Wewa is examined with following conditions.

1) Average annual storage (MCM)

Average annual storage of two reservoirs is as follows.

- Mahakanadarawa Wewa: 32.36 MCM
- Wahalkada Wewa: 23.77 MCM

2) Water intake for drinking water in 2016, 2024 and 2034

Water intake for drinking water is estimated as shown in **Table 4.12**.

Table 4.12 Water Intake for Drinking Water

| Drinking Water Supply | Mahakanadarawa Tank | | Wahalkada Tank | |
|-----------------------|-----------------------|------------|-----------------------|------------|
| | (m ³ /day) | (MCM/year) | (m ³ /day) | (MCM/year) |
| Water intake in 2016 | 6,700 | 2.45 | 10,500 | 3.83 |
| Water intake in 2024 | 9,400 | 3.25 | 14,400 | 5.26 |
| Water intake in 2034 | 18,800 | 6.53 | 28,800 | 10.00 |

3) Irrigation water

Tendency of storage variation in both reservoirs, annual irrigation water use is estimated as follows.

- Mahakanadarawa scheme: 20-30 MCM (40 MCM is corresponding to water use for FSL)
- Wahalkada scheme: 12-16 MCM

4.3.5 Mahakanadarawa Wewa

(1) Situation

For Mahakanadarawa wewa, the average annual storage is estimated at around 32.36 MCM, and the irrigation use varies between 20-30 MCM/year. On the other hand, the water supply for drinking will be annually 3.25 MCM in 2024 and 6.53 MCM in 2034. Assuming that the priority is given to water supply for drinking, the water shortage will occur even in 2016 for an irrigation use of 30 MCM/year. If the NCP Canal Project will not be completed, water allocation between irrigation and water supply for drinking will be a big issue, since an amount of water shortage will increase.

If the NCP Canal Project will be completed in 2016 as scheduled, it will catch the commencement of operation for water supply in 2018. Basically, the NCP Canal Project includes drinking water of around 70 MCM/year for 15 major towns in North Central and North Provinces. Most of the target towns served by the Mahakanadarawa water supply system under the “Anuradhapura North Integrated Water Supply Project” are corresponding to the towns covered by the NCP Canal Project. In 2034, the total amount of 80.53 MCM composed of 6.53 MCM for water supply and 74 MCM required to irrigate the maximum irrigation area of 2,420 ha of the Mahakanadarawa Irrigation Scheme, presently cultivated by irrigation and rainfall, will be necessary for both purposes. However, the average storage of Mahakanadarawa Wewa is approximately 32.36 MCM, and the balance of 48.17 MCM should be covered by the NCP Canal Project with a design capacity of 700 MCM which will make the further supplement of water possible. Therefore, an enough amount of water will be maintained for both water supply and irrigation

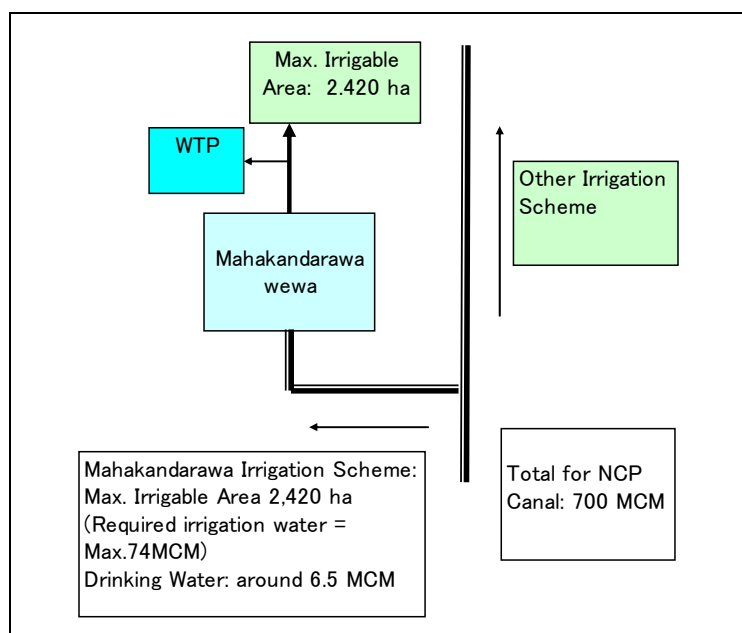

Figure 4.8 Image of Assumed Additional Water from NCP Project

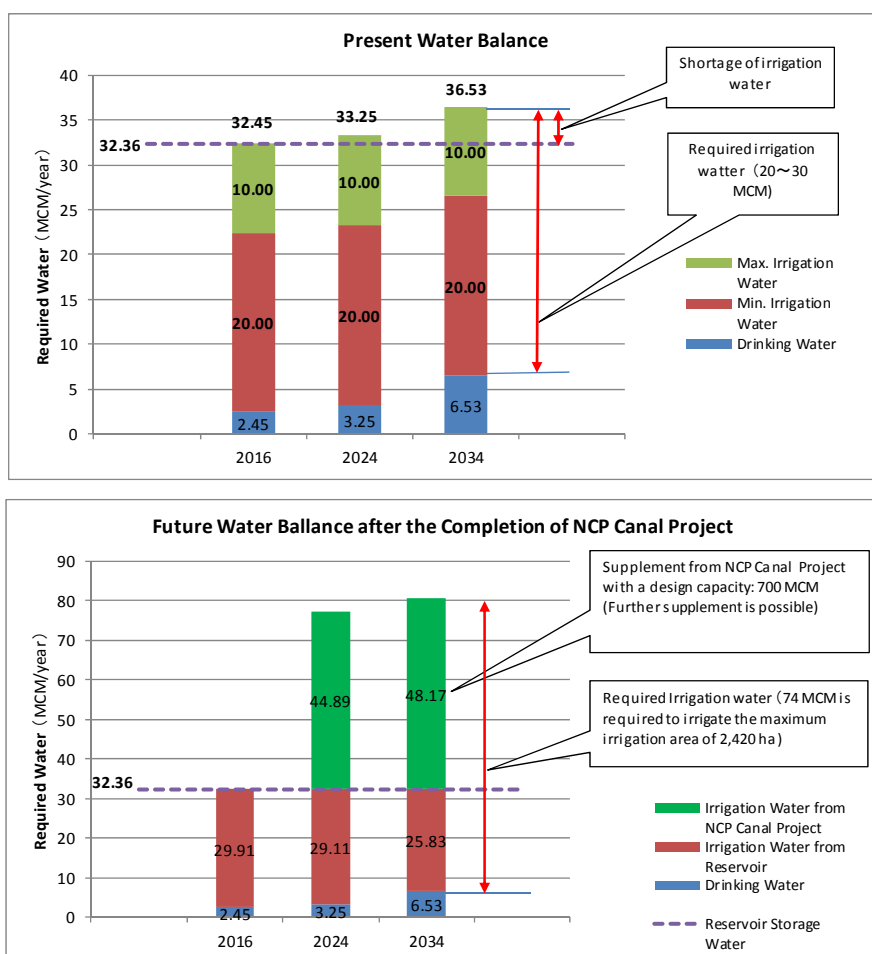

Figure 4.9 Water Availability in the Mahakanadarawa Wewa

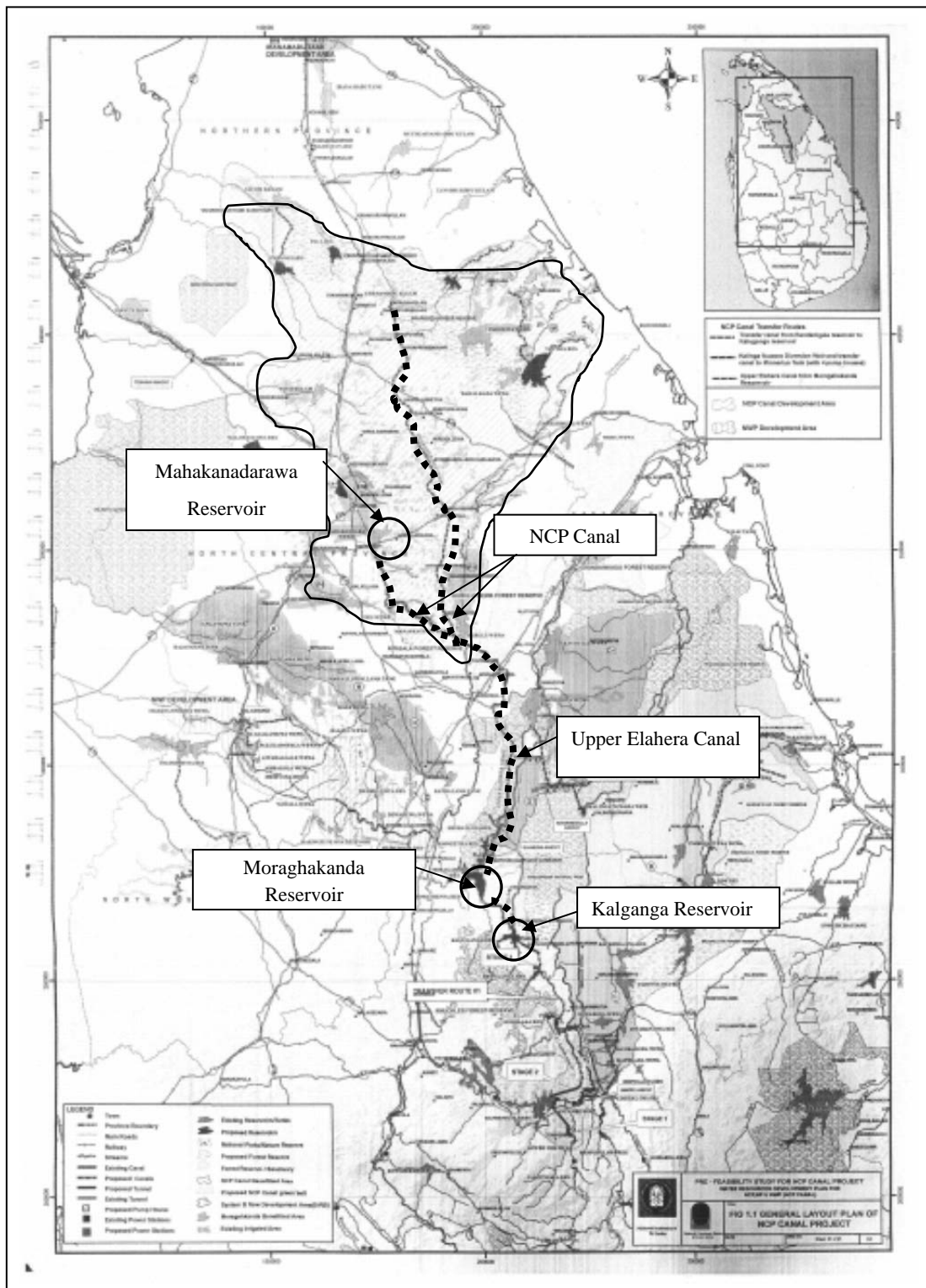

Figure 4.10 NCP Canal Development Project Location Map

(2) Implementation Schedule of the NCP Canal Project

GOSL has taken an initiative to implement the Moraghakanda/Kalu Ganga Project which was

identified as essential infrastructure for the implementation of the NCP Canal Project. The Moragahakanda/Kalu Ganga Project is under construction since 2007, and programmed to be completed by 2014. However, the Moragahakanda/Kalu Ganga project has been delayed because of financial and environmental problems. Finally, the Chinese Government agreed to provide loan assistance in 2012, then the Moragahakanda/Kalu Ganga Project started the second stage. According to the newspapers, this Project is expectedly completed by 2016. GOSL has idea to start NCP Canal Project as soon as possible. However, the finance for NCP Project is under request, and mentioned schedule of the implementation of the NCP Project is not sure.

(4) Water Quality of Planned Reservoirs

The NCP Canal Project, which plans to provide water to Mahakanadarawa, has two main water resources. One is the planned Moragahakanda reservoir and the other is Kalu Ganga reservoir. The water flow from both reservoirs to Mahakanadarawa is shown in **Figure 4.11**.

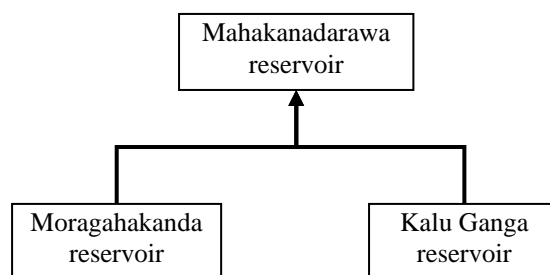

Figure 4.11 Water Flow from Both Reservoirs to Mahakanadarawa

According to the *Moragahakanda Biodiversity Study Report*, the dry seasons of this area are from January to February, and from June to September. Therefore, sampling was done in September to investigate the highest level of water quality contents.

Water quality results of the two water resources and the drinking water standards in Sri Lanka were compared. For Moragahakanda: a colour sample exceeded the desirable level, and turbidity, taste and nitrite samples exceeded the permissible level of the Sri Lankan standards. For Kalu Ganga: a colour sample exceeded the desirable level and a taste sample exceeded the permissible level of the Sri Lankan standard. However, these will be reduced through the water treatment process, thereby these excess will be resolved.

In conclusion, both water resources which will supply water to Mahakandarawa wewa will not cause any adverse impact on the water quality of the said wewa.

Table 4.13 Water Quality Results for Moragahakanda and Kalu Ganga Reservoirs

| Sampling location | Type of water source | Date | Odor | Colour | Turbidity | Taste | pH | Electrical C | Chloride | Free ammonia | Alkalinity |
|-----------------------------------|----------------------|----------|----------|------------|-----------|----------|---------|--------------|----------|--------------|------------|
| | | | | Hazen Unit | NTU | | - | µS/cm | mg/L | mg/L | mg/L |
| Moragahakanda | River | 12/09/20 | Unobjec. | 7.5 | 19 | Objec. | 7.6 | 310 | 7 | 0.05 | 65 |
| Kalu Ganga | River | 12/09/20 | Unobjec. | 5 | 1.1 | Objec. | 7.5 | 118 | 6 | <0.05 | 144 |
| Sri Lanka Standards (Desireble) | | | - | 5 | 2 | | 7.0-8.5 | 750 | 200 | | 200 |
| Sri Lanka Standards (Permissible) | | | Unobjec. | 30 | 8 | Unobjec. | 6.5-9.0 | 3500 | 1200 | 0.06 | 400 |

| Sampling location | Type of water source | Date | Albinoid ammonia | Nitrite | Nitrate | Fluoride | Phosphate | Total residue | Hardness | Iron | Sulphate |
|-----------------------------------|----------------------|----------|------------------|---------|---------|----------|-----------|---------------|----------|------|----------|
| | | | mg/L | mg/L | mg/L | mg/L | mg/L | mg/l | mg/L | mg/L | mg/L |
| Moragahakanda | River | 12/09/20 | 0.06 | 0.07 | 0.85 | 0.08 | 0.31 | 215 | 78 | <0.1 | 14 |
| Kalu Ganga | River | 12/09/20 | <0.01 | <0.01 | <0.05 | 0.11 | <0.2 | 82 | 153 | <0.1 | 13 |
| Sri Lanka Standards (Desireble) | | | | | | 0.6 | - | 500 | 250 | 0.3 | 200 |
| Sri Lanka Standards (Permissible) | | | 0.15 | 0.01 | 10 | 1.5 | 2 | 2000 | 600 | 1 | 400 |

Objec.: Objectionale, Unobjec.: Unobjectionable

In conclusion, both water resources which will supply water to Mahakandarawa wewa will not cause any adverse impact on the water quality of the said wewa.

4.3.6 Wahalkada Wewa

(1) Situation

For Wahalkada Wewa, the average annual storage is estimated at around 23.77 MCM, and the irrigation use varies between 12-16 MCM. On the other hand, the water supply for drinking will be annually 5.26 MCM in 2024 and 10.00 MCM in 2034. According to this result, this reservoir water will not be enough to cover the water use for water supply and irrigation without an appropriate allocation in 2034.

The Yan Oya Reservoir Project will have an irrigable area of 4,780 ha by a new reservoir capacity of 254 MCM. Its left side irrigation canal will pass in the Wahalkada Irrigation Scheme, and irrigate an area of around 400 ha under the Wahalkada Irrigation Scheme, based on the Proposal for Yan Oya Reservoir Project prepared by China's Contractor (CAMC Engineering Co., Ltd.). An additional water supply from Yan Oya Reservoir Project is assumed 7 MCM at the maximum as shown in **Figure 4.12**. This figure shows the water balance of the existing irrigation scheme of 800 ha because mentioned Proposal .

In other word, the Wahalkada Wewa will have an excess water with the same amount as it, namely 5.94 MCM to 11.51 MCM as shown in **Figure 4.13**. Therefore, the storage water will be enough for water supply and irrigation even in 2034.

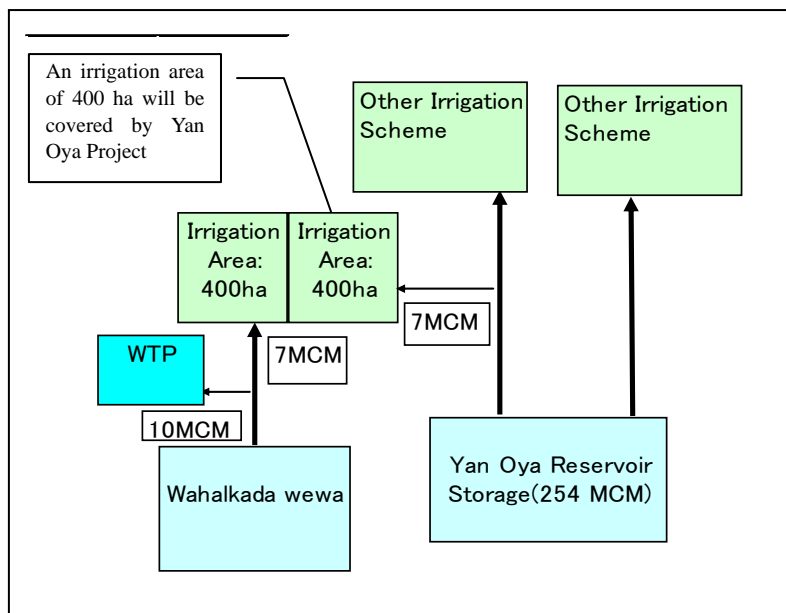

Figure 4.12 Image of Assumed Additional Water from Yan Oya Project

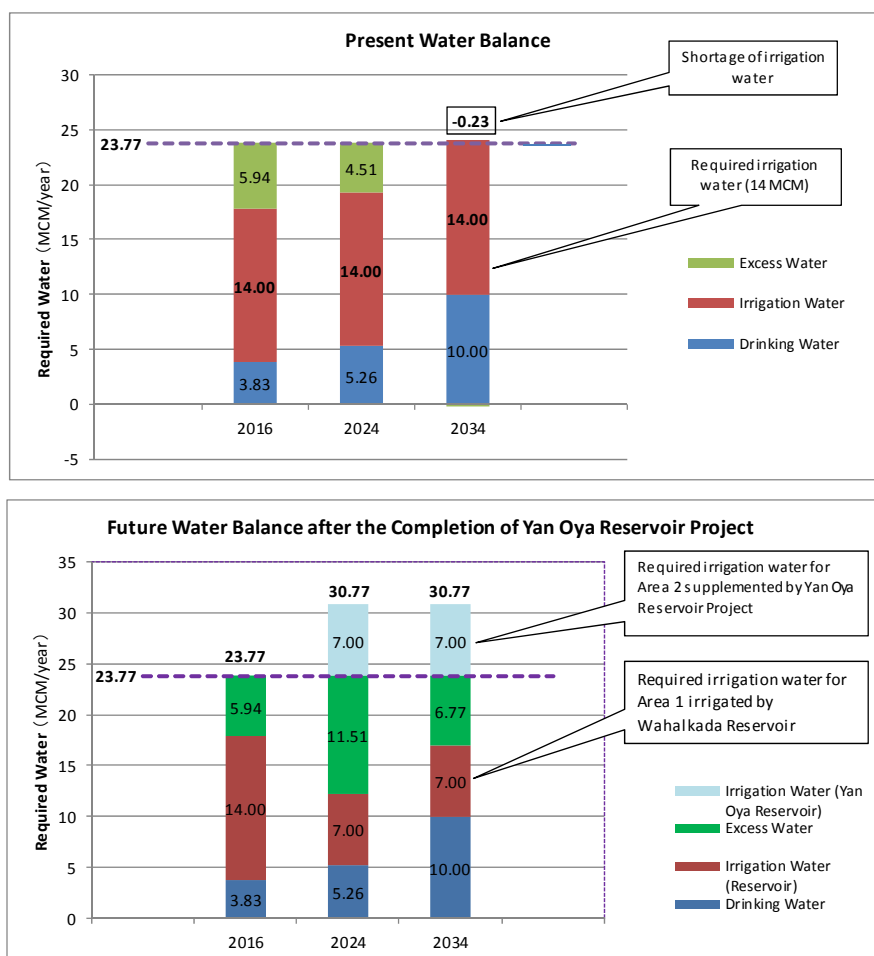

Figure 4.13 Water Availability in the Wahalkada Wewa

It should be noted that the Yan Oya Reservoir has a problem in water quality. The fluoride concentrations of the Yan Oya River has recorded 0.81 mg/L to 1.2 mg/L in May to July 2012 exceeding the Japanese drinking water standard of 0.8 mg/L, while those of the Wahalkada Wewa has kept 0.25 mg/L to 0.38 mg/L during the same period. Therefore, the water to be used for drinking water supply should be that of the Wahalkada Wewa.

(2) Implementation Schedule of the Yan Oya Reservoir Project

Financial award was signed with a project cost of Rs.19 billion between the Chinese and Sri Lankan Governments in November 4, 2011. The EIA report has been submitted to the CEA and review of it is still in progress. According to the Irrigation Department, evaluation of the EIA was expected to announce in 2012. After the approval of the EIA, the construction work is expected to start and around 4 years will be required for the completion of the project.

4.3.7 Measures against Global Climate Change

(1) Global Climate Change and Sri Lanka

According to “Climate Risk and Adaption Country Profile, Sri Lanka”, made by the Global Facility for Disaster Reduction (GFDRR) and the Team of the Environment Department of the World Bank, the following is pointed out:

- Mean annual temperatures are projected to increase by 1.0 °C. Mean rainfall is projected to change by 4%, with almost all models (Global Climate Models, etc.) showing a decrease compared to historical records, with accompanying changes in the quantity and spatial distribution of rainfall.
- Projections of future rainfall are less reliable under Global Circulation Models for island nations (in part due to their coarse spatial resolution, which fails to capture local processes driving rainfall dynamics such as feedback and convection). What is clear, however, is that climate variability and extreme events across Sri Lanka will increase in the future.

The hazard impacts of Floods and droughts across Sri Lanka are summarized below:

Historical records from 1974-2004 indicate that floods and droughts are increasing. The south-west monsoons (May to September) cause severe flooding in the western and south-western provinces; the north-east monsoon (December –February) cause flooding in the eastern, northern, and north-central provinces; while a huge part of the island is drought-prone from February to April and, if there is a subsidiary drought in the normal rainy season from May to June, drought can extend until September. In the past 30 years floods have been affecting more than 10 million people, while droughts have affected more than 6 million.

(2) Climate Change found in Anuradhapura District

According to the Ceylon Electricity Board (CEB), a shortage of power from the Hydro-power plant is compensated for by the Geo-thermal power plant, therefore daily Rs..200 million is losing by this situation.

| | |
|--------------|-------|
| Kotmale: | 35% |
| Victoria: | 14.7% |
| Randenigala: | 18.4% |
| Castlereigh: | 14.0% |

Concerning agriculture, the Ministry of Agriculture announced that a total of 150,000 acres of paddy field was damaged in Anuradhapura, Polonnaruwa, Jaffna, Kilinochchi, Puttalam, Kurunegala, Batticaloa, Ampara, Moneragala, Nuwara, Eliya Districts.

In the case of drinking water, the quantity of water stored in reservoirs is a concern. Additionally, when the villagers don't have piped water, they have a tendency to get damage. Because they usually use shallow wells, diameter is 1-2 m & depth in 10m, and this draught makes water level lowering and drying water of the well. Therefore, they need to carry water from the place of deep tube well by CBO/NWSDB with small plastic container.

(3) Measures against Global Climate Change

Measures against Global Climate Change by the Project are expected on "Improvement of the rural water supply" and "Improvement of water resource management".

1) Improvement of the rural water supply

The target area of the Project is in the Anuradhapura North area, covering a population of around 200,000 in 2012 and around 280,00 in 2034, a significant increase in the population from 2012.

From this population, the population served NWSDB's water is estimated at about 50,000-60,000 (25-30%); therefore 70-75 % of population is using shallow wells constructed in the garden of their houses.

As mentioned above, dug well can get influence of draught, draw down of water level, and many villagers need to face bring water from other locations. If they have a water source from NWSDB nearby their houses they can bring water using plastic tanks. However if this source is not available, they have no choice but to use water from ponds or swamps.

The Project aims to distribute safety water to the local people in this area, via water treatment plant(s) using surface water from Mahakanadarawa wewa and Wahalkada wewa. Therefore, this Project will contribute to avoid water supply problems which are caused by climate change in the Project Area.

2) Improvement of water resource management

In the Project, the water source will be from existing reservoirs Mahakanadarawa and Wahalkada. Supplementary water will be expected from the “Yan Oya Reservoir Project” and the “NCP Canal Development Project” in the future. Allocation of water between irrigation water and other uses will be an important issue for the Project when droughts occur. This allocation will be decided at a meeting of officers from ID, NWSDB, Divisional secretary and a representative of the Project Management Committees established under the irrigation ordinance and chaired by the District Secretary (from draft of memorandum of understanding between ID and NWSDB for extracting water from Mahakanadarawa wewa & Wahalkada wewa for the Anuradhapura North Water Supply Scheme). Therefore, improved water management will be expected as a result of the Project.

CHAPTER 5 PLAN OF PROPOSED WATER SUPPLY SYSTEM

5.1 Water Intake Works

5.1.1 Selection of Water Intake Method

This section reviews the various intake methods such as the intake well, pontoon, rail and canal types in order to decide the most suitable intake method for this Project.

The Irrigation Department, as management entity for the Mahakanadarawa and Wahalkada Reservoirs, considered intake methods for the Project, and decided that only the canal intake method is suitable because of the following reasons.

- The Irrigation Department has experience that the construction of the foundations of intake wells damaged the bank when construction took place in 1986 at the Kantale reservoir. Therefore direct construction on the bank and inside the reservoir is not approved as of now.
- Direct construction on the bank and inside the reservoir will be subject to an EIA Study, which will take time.
- Many farmers, fishermen and persons concerned with environmental organizations are anxious about the new intake well, because of the perception that an excessive amount of water will be drawn out, thus affecting these stakeholders.

The locations of the intake at the canal in Mahakanadarawa and Wahalkada tanks are selected in conjunction with the Irrigation Department and Water Board, with the distance from the banks of the reservoirs being more than 100m at high water level.

Considerable challenges of this intake method from irrigation canal are as follows.

(a) Aging risk of the facility

Around 50 years have passed after construction of Mahakanadarawa Wewa, and approximately 40 years for the Wahalakda Wewa.

Information of the aged reservoirs is available in the home page of “Dam Safety and Water Resources Planning Project (DSWRPP)” under the Ministry of Irrigation and Water Resources Management. Although the 32 dams are designated to be rehabilitated by responsible organization, Mahakanadarawa Wewa and Wahalkada Wewa are not included therein. However, the condition of its concrete structure and mechanical devices has been observed to have significantly aged. There is possibility that the existing intake wells and installed mechanical devices at the gate may break, and if repairs are not undertaken promptly, then drinking water supply may be disrupted.

Therefore, it is recommended that NWSDB make equipment like submersible water pump and

generator available in case of emergency.

(b) Measurement, Record and Control of intake discharge

Water released for irrigation use from Mahakanadarawa Wewa and Wahalkada Wewa is controlled by the operators of Irrigation Department. This is performed using the sluice gate of the intake well, and discharge volume is measured by gate's opening and reservoir's water level.

In the case of the Wahalkada scheme, a Parshall flume is installed near the small bridge to the temple. The Padaviya Irrigation Engineer's Office said the discharge is examined with this device.

Drinking water will be supplied based on the agreement between Irrigation Department and NWSDB. A Memorandum of Understanding (MOU) for extracting water from Mahakanadarawa Wewa and Wahalkada Wewa for the Anuradhapura North Water Supply Scheme is in Article 3 shown in **Table 5.1**.

Table 5.1 Memorandum for Extracting Water

| Year | 2016 | 2034 | Remarks |
|----------------|----------------------------|----------------------------|--|
| Mahakanadarawa | 6,700 m ³ /day | 18,800 m ³ /day | Amount in 2016 will be after completion of WTP Amount in long term plan will be after completion of Upper Elahara Canal Project |
| Wahalkada | 10,500 m ³ /day | 28,800 m ³ /day | |

In case of periods of exceptional water scarcity, Article 9 mentions that the Irrigation Department, Irrigation Management Division, NWSDB, Divisional Secretary, Member of Project Management Committee (established under the Irrigation Ordinance and chaired by the District Secretary) will hold a meeting and decide on water allocation rights.

In conducting water management of the reservoirs with Irrigation Department, the measurement and record of the discharge and sharing of information and control of discharge issues should be considered.

Water resource management of both reservoirs with Irrigation Department should be established under a reliable relationship, thus it is recommended that accurate measurement of discharge should be made and information sharing between agencies be maintained regularly and/or periodically.

5.1.2 Design Criteria

Design criteria for the intake work are as follows.

- (1) The location of the intake facility is more than 100m from high water level.
- (2) Design discharge between the sluice and intake for drinking water is the total amount of

maximum irrigation water supply and daily maximum of drinking water in 2034.

- (3) Mahakanadarawa irrigation scheme has two irrigation canals, i.e., the right bank canal and the left bank canal. Topographic condition of intake in the reservoir is reviewed with reservoir's planning map transferred from the Irrigation Department. Surrounding area of the left bank intake well is deep, i.e., it is considered to keep enough depth to take water even in dry season. However, the area of the right bank well is relatively shallow, i.e., there is a risk that intake water will decrease in dry season. Finally, the left bank side was selected for the location of the intake facility for drinking water.
- (4) The timing of and quantity of discharge of irrigation water supply varies in the Yala and Maha period. Canal discharge is assumed as follows.
- No irrigation period: Discharge for drinking water
 - Irrigation period: Discharge for drinking water and irrigation water

5.1.3 Outline of Water Intake Facilities

(1) Mahakanadarawa Intake

The shape of the canal at the proposed intake point is rectangular, with the canal having a concrete lining. The following design criteria are applied, based on the calculation using Manning's Formula.

Table 5.2 Design Criteria for Intake Facilities

| | Mahakanadarawa | Wahalkada |
|--|--|--|
| Max. irrigation discharge | 3.4 m ³ /sec | 2.0 m ³ /sec |
| Max. intake discharge for drinking water | 0.22 m ³ /sec (18,800 m ³ /day in 2034) | 0.34 m ³ /sec (28,800 m ³ /day in 2034) |
| Canal discharge in irrigation period | 0.62~3.62 m ³ /sec | 0.7~2.34 m ³ /sec |
| Width of existing irrigation canal at intake point | 3.5 m | 4.5 m |
| Height of existing canal | 2.2 m | 2.1 m |
| Max. water depth in canal | 1.45 m | 0.91 m |
| Water depth just for drinking water in 2034 | 0.22 m | 0.32 m |
| Design height of lower portion of the canal | 0.30 m | 0.40 m |
| Max. water level for irrigation and drinking water | 1.51 m | 1.00 m |

Figure 5.1 and **Figure 5.2** shows the outline of intake facility for Mahakanadarawa and Wahalkada Systems, respectively.

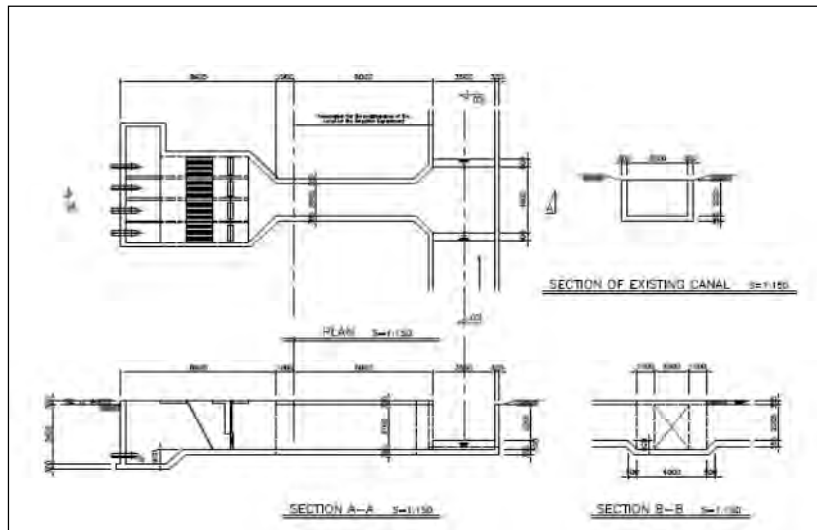

Figure 5.1 Outline of Intake Facility in Mahakanadarawa Wewa

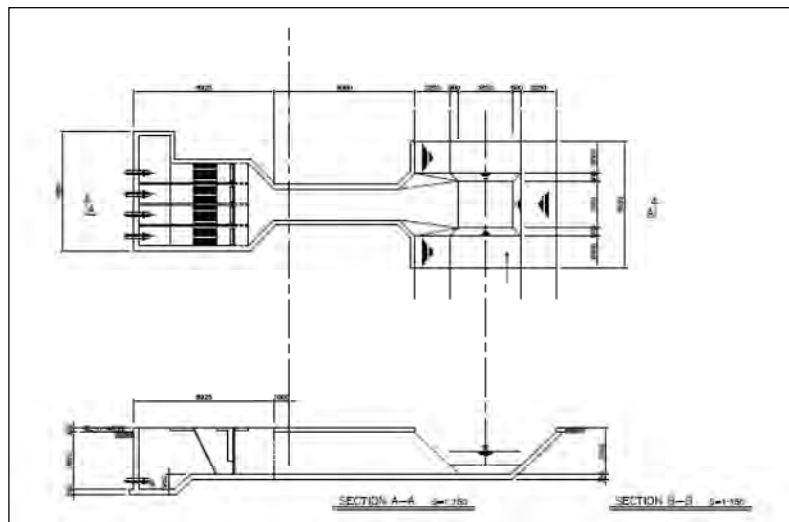

Figure 5.2 Outline of Intake Facility in Wahalkada Wewa

5.2 Water Treatment Plant

5.2.1 Stage Construction of water treatment Plants

Since the water transmission and distribution facilities is constructed with a full design capacity for the year of 2034 due to the difficulty in split construction, the water treatment plant, etc. to which stage construction is applicable, shall be constructed with a capacity for the year of 2024 to reduce an initial investment as much as possible.

The following are the reasons adopting stage construction in this Project:

(1) NWSDB Design Criteria

NWSDB Design Manual (March 1989) describes that “As a general principle it is recommended that future urban schemes be designed for a 20-year planning horizon in two 10-year stages”. Therefore, it is reasonable to set the target year in 2034 with an interim target year of 2024 for stage construction.

(2) NWSDB Guideline for Rural water Supply

The NWSDB Guidelines suggest the difficulty to increase the population coverage by water supply in the rural area. Although the willingness of the people to connect to the proposed pipe borne water supply system to be operated and maintained by NWSDB seems high due to the high level content of fluoride in groundwater as a water source in the study area, there is a risk to overestimate it.

1) Difficulty to increase the coverage

The change in the number of connections since the commissioning year even at five water supply systems under NWSDB in the study area was very slow. Since the people with high expectation for pipe bore water supply would like to connect to a system as soon as possible, the connection works to a system will have a peak during a few years after the completion of a system and thereafter become slow in general.

2) Alternative water source in rural area

92.8% of the people in the study area have any types of their own water sources (although almost relying on groundwater). Whether the people will connect to a water supply system or not is left to their discretion. There are many cases that the coverage increased less than expected so far. It should be noted that a quarter of the people didn't use a toilet in 2001 and the percentage of the household population below the poverty line was high as 28.2% against the district average of 20.0% in 2002.

3) Selective use of either tap water or groundwater

Even though connected to a water supply system, the people may use either of groundwater or tap water selectively by use, that is to say, a coverage ratio will increase, but water demand will not increase so much. Therefore, it is advisable to watch the change of actual water demand carefully but not the apparent coverage ratio.

According the Census 2011, the major drinking water source survey reveals that 75.4% of the people in the study area rely on groundwater from dug well (72.6%) and tube well (2.8%), respectively, 18.9% on tap water and remaining 5.7% on others such as bowser, bottled water, river, etc. According to the existing CBO water supply facility survey in **Section 3.3.1**, the population coverage by water supply is approximately 27% including those under NWSDB. It may suggest that some customers doesn't regard tap water as the main drinking water source in spite of the connection to a water supply system.

4) Long-term pipe installation work

Even though the pipe borne water supply is applied to GNDs, it will take a long time to attain the full population coverage, since a population density of 100 persons per km² means that a housing unit (HU) is located every 100 m to 400 m, assuming that it is occupied by 4 persons on average.

$$100 \text{ persons/km}^2 = 1 \text{ person/ha} = 4 \text{ persons/4 ha} = 1 \text{ HU/4 ha}$$

(3) Waste in full construction

If the equipment is installed in full construction but not in stage construction, a variety of waste will occur. Some extent of water demand will be maintained through the connection of existing NWSDB and CBO water supply schemes to a new system but thereafter the water supply amount will rely on the growth in the number of connections and per capita water consumption. However, since there is no occurrence of such situation that the water demand will at once reach to a design capacity, the equipment once installed will be unavoidably idle and the following situations will occur.

- The service life of mechanical and electrical equipment is generally ten to fifteen years. It is counted from the time installed and wasted.
- Once the equipment is installed, it is required to operate it in the rotation programme even though the water supply amount is less, which makes plant operation complicated. Since the deterioration occurs leaving it without any maintenance after operation, cleaning and inspection of such equipment are also necessary.
- The replacement of equipment will be concentrated in specific years which will be a big financial burden.

(4) Deterioration of FIRR

In case of full construction of a water treatment plant, it is possible to reduce the price of materials used for the construction work through a mass order, cut the expenses by shortening the overall construction period, and to finally reduce the construction cost as a whole. However, by full construction, an initial investment will increase and some mechanical and electrical equipment will be installed earlier than scheduled resulting in their earlier replacement. Here assuming that the total construction cost will be reduced by 10%, the comparative study of FIRR is done between the stage construction and full construction. As there will be no increase in water demand and revenue even though the full construction will be adopted, and the increase in an initial investment, FIRR will be worsened as shown in **Table 5.3**.

Table 5.3 FIRR Comparison between Stage and Full Constructions

| (1) Stage Construction | | | | | (2) Full Construction (10% Reduction) | | | | |
|------------------------|------------|----------|--------------|-----------|---------------------------------------|------------|----------|--------------|-----------|
| Year | Investment | Revenues | Expenditures | Cash flow | Year | Investment | Revenues | Expenditures | Cash flow |
| 2012 | 0.0 | | | 0 | 2012 | 0.0 | | | 0 |
| 2013 | 82.2 | | | -82.2 | 2013 | 81.8 | | | -81.8 |
| 2014 | 437.5 | | | -437.5 | 2014 | 437.2 | | | -437.2 |
| 2015 | 1,093.1 | | | -1,093 | 2015 | 1,126.9 | | | -1,127 |
| 2016 | 3,508.7 | | | -3,509 | 2016 | 3,645.1 | | | -3,645 |
| 2017 | 3,641.5 | | | -3,642 | 2017 | 3,777.9 | | | -3,778 |
| 2018 | 960.1 | 56 | 34 | -938.1 | 2018 | 994.0 | 56 | 34 | -972 |
| 2019 | 14.9 | 78 | 46 | 17.1 | 2019 | 14.6 | 78 | 46 | 17.4 |
| 2020 | | 82 | 48 | 34 | 2020 | | 82 | 48 | 34 |
| 2021 | | 86 | 49 | 37 | 2021 | | 86 | 49 | 37 |
| 2022 | | 90 | 51 | 39 | 2022 | | 90 | 51 | 39 |
| 2023 | | 94 | 53 | 41 | 2023 | | 94 | 53 | 41 |
| 2024 | 786.5 | 98 | 54 | -742.5 | 2024 | | 98 | 54 | 44 |
| 2025 | | 108 | 66 | 42 | 2025 | | 108 | 66 | 42 |
| 2026 | | 117 | 71 | 46 | 2026 | | 117 | 71 | 46 |
| 2027 | | 127 | 76 | 51 | 2027 | | 127 | 76 | 51 |
| 2028 | | 137 | 80 | 57 | 2028 | | 137 | 80 | 57 |
| 2029 | | 147 | 85 | 62 | 2029 | | 147 | 85 | 62 |
| 2030 | | 157 | 90 | 67 | 2030 | | 157 | 90 | 67 |
| 2031 | | 167 | 95 | 72 | 2031 | | 167 | 95 | 72 |
| 2032 | | 177 | 100 | 77 | 2032 | | 177 | 100 | 77 |
| 2033 | | 187 | 104 | 83 | 2033 | 786.5 | 187 | 104 | -703.5 |
| 2034 | | 197 | 109 | 88 | 2034 | | 197 | 109 | 88 |
| 2035 | | 207 | 114 | 93 | 2035 | | 207 | 114 | 93 |
| 2036 | | 217 | 119 | 98 | 2036 | | 217 | 119 | 98 |
| 2037 | | 227 | 124 | 103 | 2037 | | 227 | 124 | 103 |
| 2038 | | 237 | 128 | 109 | 2038 | | 237 | 128 | 109 |
| 2039 | -4,674 | 247 | 133 | 4,788 | 2039 | -4,950 | 247 | 133 | 5,064 |
| | FIRR | | | -2.65% | | FIRR | | | -2.69% |

(5) Progress of irrigation projects

According to the plan, the NCP Canal and Yan Oya Reservoir projects that supplement the water supply condition of Mahakanadarawa and Wahalkada Tanks will be completed around the time that new water supply systems will be completed. However, these projects have not yet started and the completion time of them has not been assured. In addition, the possibility that the delay and/or suspension of their construction works will occur, should be taken into account. Since the farmers' association will never allow to use water with more than the amount admitted as the water right for drinking water supply, as long as the proposed irrigation projects will not be completed, there is a high risk to construct a water treatment plant at once with a full design capacity for the year of 2034.

5.2.2 Selection of Water Treatment Process**(1) Raw water quality**

The water quality of Mahakanadarawa and Wahalkada irrigation tanks is shown in **Table 5.4** and **Table 5.5**. Both irrigation tanks will be the water source for the proposed WTPs in the project. Turbidity and color in both water sources are low, but the pH is high and similar to that in the

water sources of the existing WTPs.

Table 5.4 Raw Water Quality

| | Date | Water Temperature (°C) | Dissolved Oxygen ¹⁾ (mg/L) | pH | Turbidity (degree) | Color (degree) | Odor |
|----------------------------|------------|------------------------|---------------------------------------|------|--------------------|----------------|-------|
| Wahalakada Tank | | | | | | | |
| Surface water | 17/05/2012 | 30.1 | 8.3 | 8.89 | 12.4 | 26.5 | None |
| Bottom water | Ditto | 30.0 | 7.2 | - | - | - | ditto |
| Mahakanadarawa Tank | | | | | | | |
| Surface water | 15/05/2012 | 29.4 | 7.2 | 8.46 | 7.3 | 22.5 | None |
| Bottom water | ditto | 29.3 | 6.2 | 8.36 | 10.9 | 31 | ditto |

Table 5.5 Odor of Raw Water

| | 04/07/2012 | 08/07/2012 | 17/07/2012 | 25/07/2012 | 28/07/2012 |
|----------------|----------------|------------|--------------|------------|------------|
| Wahalakada | Muddy or musty | | | No odor | No odor |
| Mahakanadarawa | | No odor | | | |
| Thuruwila | | | Strong muddy | | |

(2) Selection of the water treatment process

There are two major treatment processes to select: slow sand filters and rapid sand filters.

Slow sand filters are simple, cost effective, reliable, and easy to operate. However slow sand filters generally treat source water turbidity of less than 10 degrees successfully. Rapid sand filters can treat high turbidity water if the water is properly coagulated and settled out. The turbidity of Mahakanadarawa and Wahalkada water is higher than 10 degrees and ranges 1 to 20 degrees. There is a possibility that roughing filters can serve as a pretreatment to reduce the turbidity loading to the slow sand filters. To determine the applicability of the slow sand filters with help of roughing filters, pilot plant tests were conducted.

During the pilot plant operation, the water in the water source and the water treated by roughing filter contained much higher turbidity than water suitable for slow sand filter systems. Therefore, this condition was not suitable for slow sand filters to function properly and efficiently. Even the velocity in the sand filters were set lower than the original calculated velocity, the turbidity was insufficiently removed, less than 5 degrees. For the color, no difference was observed and the treated water was yellowish green color as shown in **Figure 5.3**.

The rapid sand filter can remove the turbidity and color as confirmed by a jar test. The water source used for the pilot plan operation was taken during the middle of dry season which could affect the experiment results. For a purpose of the portable water sources, the Anuradhapura North Water Supply project is proposed to intake the water from Mahakandarawa Tank and

Wahalkada Tank, which currently used only for the irrigation purpose. With the additional intake of the water for the portable water purpose, the water levels in both tanks can be lower than the current condition, and the similar condition to the Anuradhapura City Water Supply can be predicted. In considerations of the above conditions and results, the implementation of slow sand filter system for the project is not suitable and recommended. In conclusion, the implementation of rapid sand filter system is recommended for the Anuradhapura North Water Supply project. Rapid sand filter systems are widely used in Sri Lanka so that Water Board will have no difficulties in operation and maintenance. Also it is recommended to install ACF (Active Carbon Filter) as soon as possible to remove the odor, if a bad odor occurred in the treated water for a long period, after operation of Phase - 1 facility started. Wooden and coconut granular carbon produced in Sri Lanka is available there. Some water treatment plants in Sri Lanka use powder and granular activated carbon.

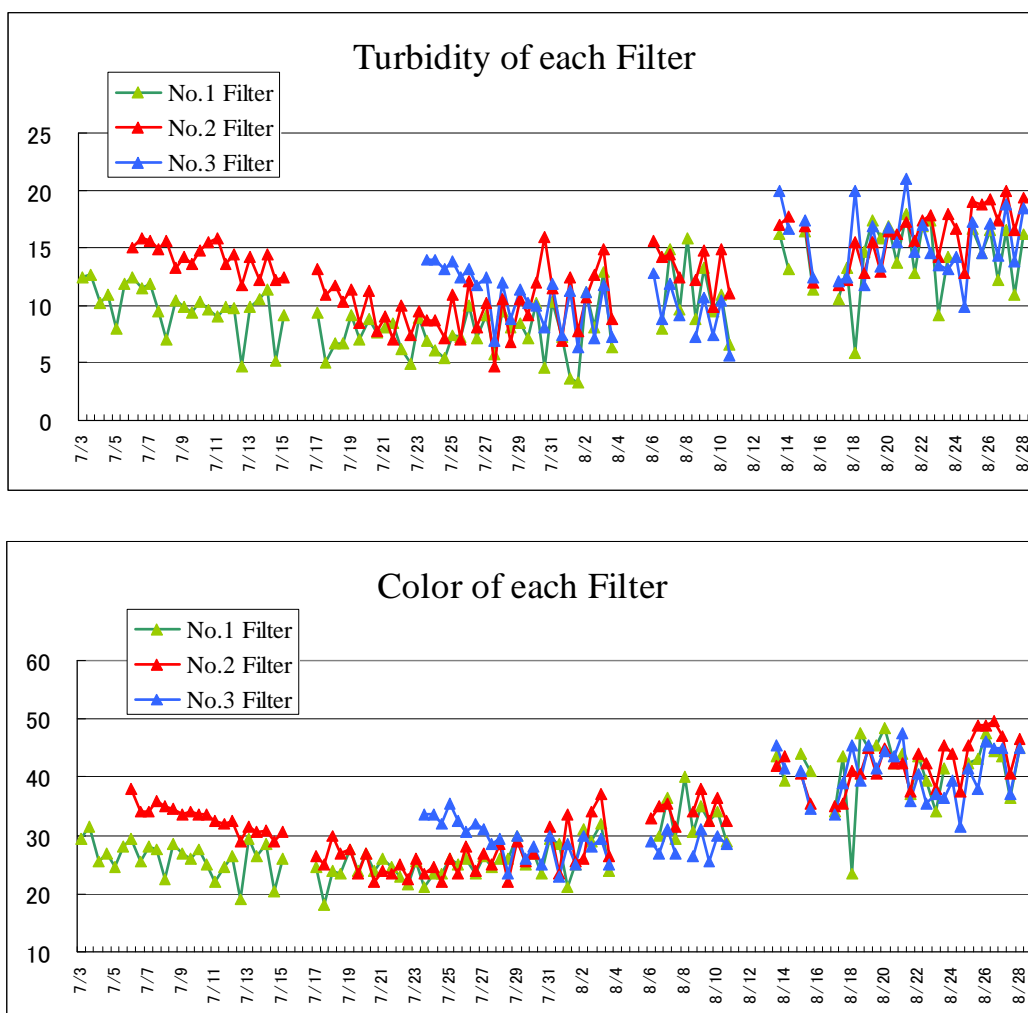

Figure 5.3 Treated Water Quality in Each Sand Filter at the Pilot Plant

Table 5.6 Results of the Jar Tests (Surface Water of Mahakanadarawa Tank)

| Parameter | Raw water | Aluminum sulfate dosage rate (mg/L) | | | | | |
|--------------------|-----------|-------------------------------------|------|------|------|------|-----|
| | | 20 | 40 | 60 | 80 | 100 | 120 |
| pH | 8.46 | 7.83 | 7.44 | 7.37 | 7.13 | 6.93 | 6.8 |
| Turbidity (degree) | 7.3 | 4.9 | 2.6 | 1.3 | 0.5 | 0.1 | 0.0 |
| Color (degree) | 22.5 | 16.0 | 9.5 | 7.0 | 4.5 | 3.0 | 2.0 |

5.2.3 Design Criteria

The design criteria of the facilities are shown in **Table 5.7**.

Table 5.7 Design Criteria

| Facility Name | Item | Value |
|--|-----------------------------------|--|
| Receiving Well/distribution tank | Detention Time | More than 1.5min |
| Flocculator | Detention Time | 20-40 min |
| | G value | 10 - 75/s |
| | GT value | 23,000 to 210,000 |
| Sedimentation tank (plate settler) | Surface load of the plate settler | 7 – 14mm/min |
| | Upward flow velocity | < 80 mm/min |
| Sand filter | Filtration rate | < 200m/d (when one tank is stand by) |
| ACF (Active Carbon Filter) sump (future) | Detention Time | 5-25 min |
| ACF (Active Carbon Filter: future) | Space velocity | SV=5 – 10 /hr |
| Clear water reservoir | Detention Time | 1 hr |
| Backwash water recycle tank | Capacity | > amount of backwash water of 2 sand filters |
| Thickener | Detention Time of sludge | 24 – 48 hr |
| | Loading rate of sludge | 10 – 20 kg/m ² /d |
| Drying bed | Loading rate of sludge | 40 – 80 kg/m ² |

Source: “Design Criteria for Waterworks Facilities”, Japan Water Works Association, 2000
 “Integrated Design of Water Treatment Facilities”, Susumu Kawamura, 1991

5.2.4 Mahakanadarawa WTP

(1) Flow diagram

The flow diagram of Mahakanadarawa WTP is shown in **Figure 5.4**.

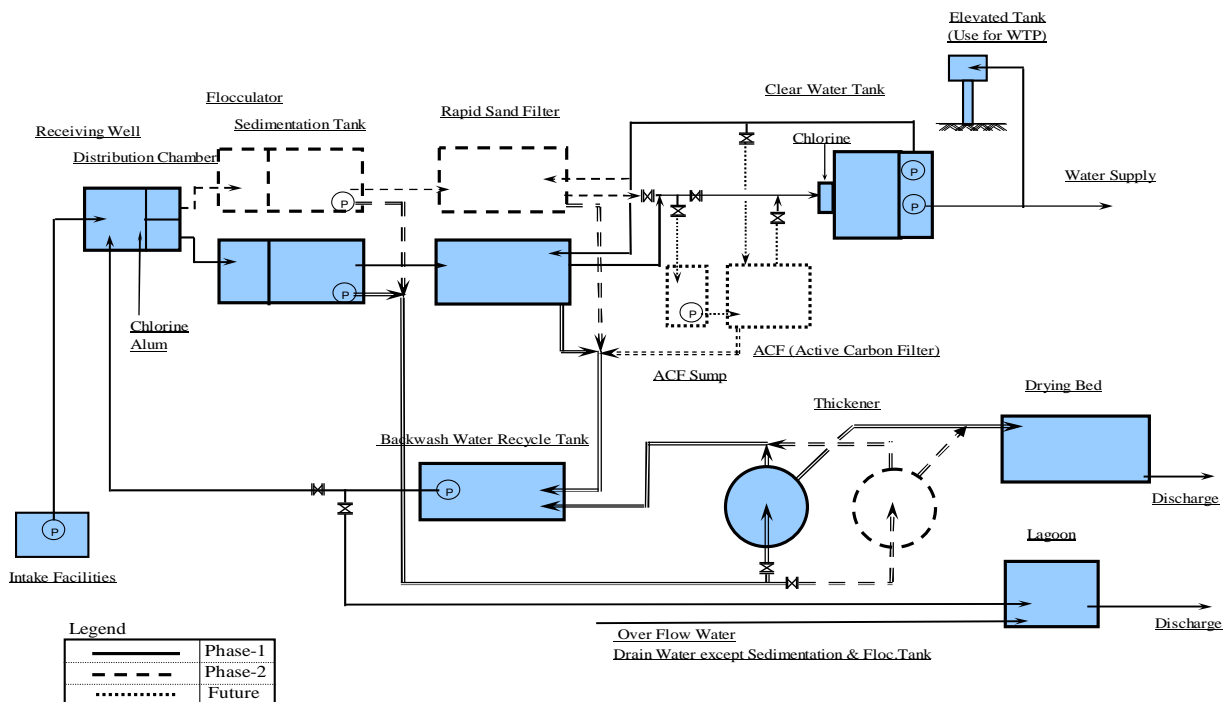

Figure 5.4 Flow Diagram of Mahakanadarawa WTP

(2) Layout

The layout of the facilities in Mahakanadarawa WTP is shown in Figure 5.5. Figure 5.5.

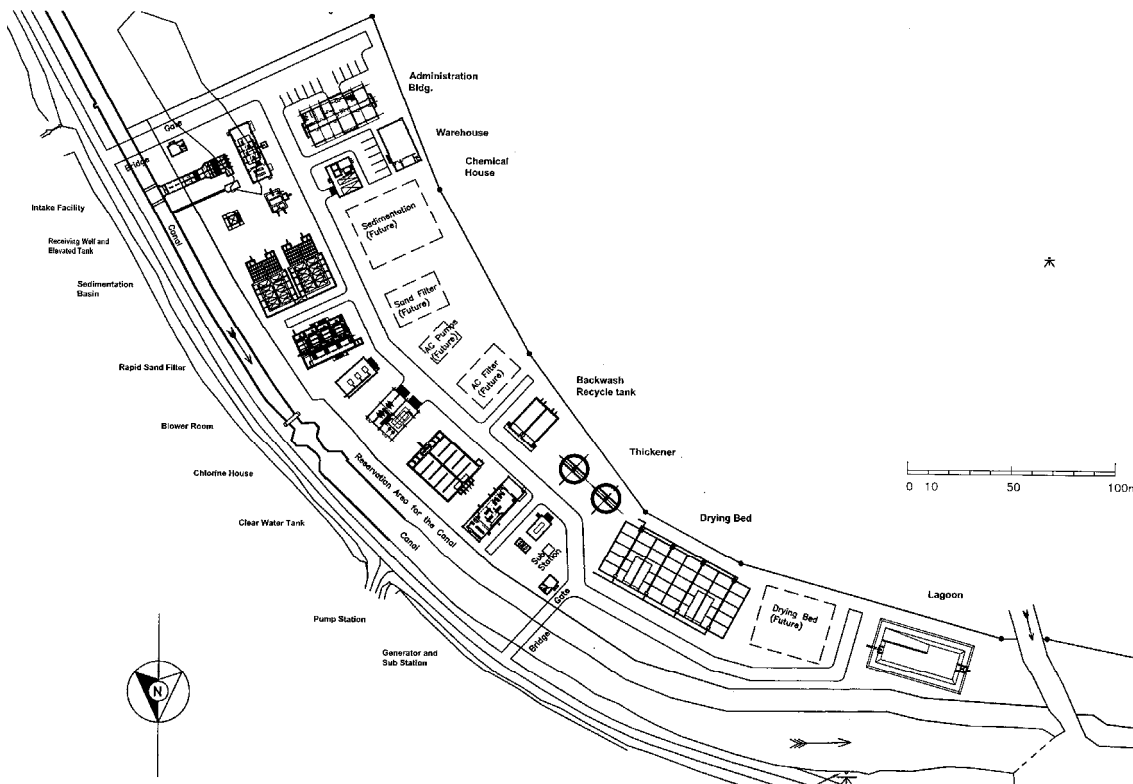

Figure 5.5 Layout of Mahakanadarawa WTP

(3) Outline of Mahakanadarawa WTP

Mahakanadarawa WTP takes water from an irrigation canal from Mahakanadarawa Tank at approximately 120 m downstream of Mahakanadarawa Tank. The WTP is located on the left of the irrigation channel. The capacity of the WTP including 5% treatment process loss is shown in **Table 5.8**.

Table 5.8 Capacity of Mahakanadarawa WTP

| Year | Stage-1 (2024) | Stage-2 (2034) | Remarks |
|---|----------------|----------------|---------------------------------------|
| Water rights (m ³ /d) | —* | 18,800 | |
| Water demand (day ave.) (m ³ /d) | 7,154 | 14,414 | According to water demand projection |
| Water demand (day Max.) (m ³ /d) | 8,600 | 17,300 | day ave. x 1.2 |
| Production capacity of WTP(m ³ /d) | 8,900 | 17,900 | Output of WTP; Capacity of WTP x 0.95 |
| Capacity of WTP (m ³ /d) | 9,400 | 18,800 | Input to WTP |

Note: * Water right is set at 6,700 m³/day for 2016 and 18,800 m³/day for 2034 in the MOU between the Irrigation Department and NWSDB. Therefore, it is supposed that an amount of 6,700- 18,800 m³/day will be available for the year of 2024.

The intake water is delivered to the receiving well, which includes distribution chambers to supply water evenly to the flocculator tank that will be constructed in Stage-1 and long term plan. At the outflow of the receiving well, both chlorine and aluminum sulfate will be injected. A weir and a valve are installed at the entrance at each flocculator tank to control the inflow. The outflow from the vertical baffled channel flocculator is conveyed to the inclined plate sedimentation tank, which removes sludge. The outflow from the sedimentation tank without sludge is conveyed to a rapid sand filter, and then the filtered water is conveyed to the clear water reservoir, to which chlorine is added.

After the start the operation of Stage-1 facilities, if strong bad odor occurs for a long term in the treated water, ACF is proposed to be added to remove the odor. The outflow from the rapid sand filter is proposed to be pumped into the ACF by an ACP sump pump. The filtered water is conveyed to the clear water reservoir by gravity, and the treated water is supplied to the served area by transmission pumps.

Both the sand filter and ACF are cleaned with air and water. The backwash water flows into the backwash water recycle tank and then pumped to the receiving well for recycling water.

Sludge collected at the bottom of the sedimentation tank is regularly released by opening a valve and pumped to the thickener. In the thickener, water is separated from the sludge, the sludge is conveyed to the drying bed, and the water is conveyed to the backwash water recycle

tank for a purpose of recycling water. Accumulated sludge in the drying bed is removed after this is dried. The total capacity of lagoons is designed to handle the overflow water, drainage water, and the water from the backwash water recycle tank for emergency.

The facilities in Mahakanadarawa WTP are summarized in **Table 5.9**.

Table 5.9 Detail of Mahakanadarawa WTP

| Facility | Stage-1 | Strage-2 | Remarks |
|--|---|---|---------------|
| Receiving Well | W4.0m x L4.6m x H6.0m x 1unit | - | * |
| Distribution Chamber | W2.0m x L2.0m x H5.0m x 2units | - | * |
| Flocculator tank | 5 stages x 62.8m ³ x 4 units | 5 stages x 62.8m ³ x 4 units | |
| Sedimentation tank | W4.0m x L10.4m x H4.0m x 4units | W4.0m x L10.4m x H4.0m x 4unit | Plate settler |
| Rapid sand filter tank | W3.0m x L5.5m x 4units | W3.0m x L5.5m x 4units | |
| ACF sump | W8.0m x L12.0m x H3.0m x 1unit | | future |
| ACF tank | W2.5m x L5.0m x 4units | | future |
| Chlorine Mixing Chamber | W2.0m x L5.0m x H4.0m x 2units | - | * |
| Reservoir | W8.0m x L17.0 x H4.0m x 2units | - | * |
| Backwash water recycle tank | W4.0m x L14.0 x H3.0m x 2units | - | * |
| Thickener | Dia 10.0m x H4.0m x 1unit | Dia 10.0m x H4.0m x 1unit | |
| Drying bed | W12.5m x L20.0m x H1.0m x 4units | W12.5m x L20.0m x H1.0m x 2units | |
| Lagoon | W10.0m x 27.0m x 1.0m x 1unit | - | * |
| Administration Bldg. | W12.0m x L25m x 2 stories | - | * |
| Chemical house | W11.5m x L12.0m | - | * |
| Chlorine House including neutralization facilities | W12.0m x L14.0m | - | * |
| Pump House | W8.0m x L26.5m | - | * |
| Blower House | W7.3m x L13.5m | | * |
| Generator House | W4.5m x L8.0m | - | * |
| Ware House | W10.0m x L17.0m | - | * |

*The capacity of the facilities constructed in Stage-1 includes the whole capacity required for the Project up to Stage-2.

5.2.5 Wahalkada WTP

(1) Flow diagram

The flow diagram of Wahalkada WTP is the same as in **Figure 5.4**.

(2) Layout of the facilities

The layout of the facilities in Wahalkada WTP is shown in **Figure 5.6**.

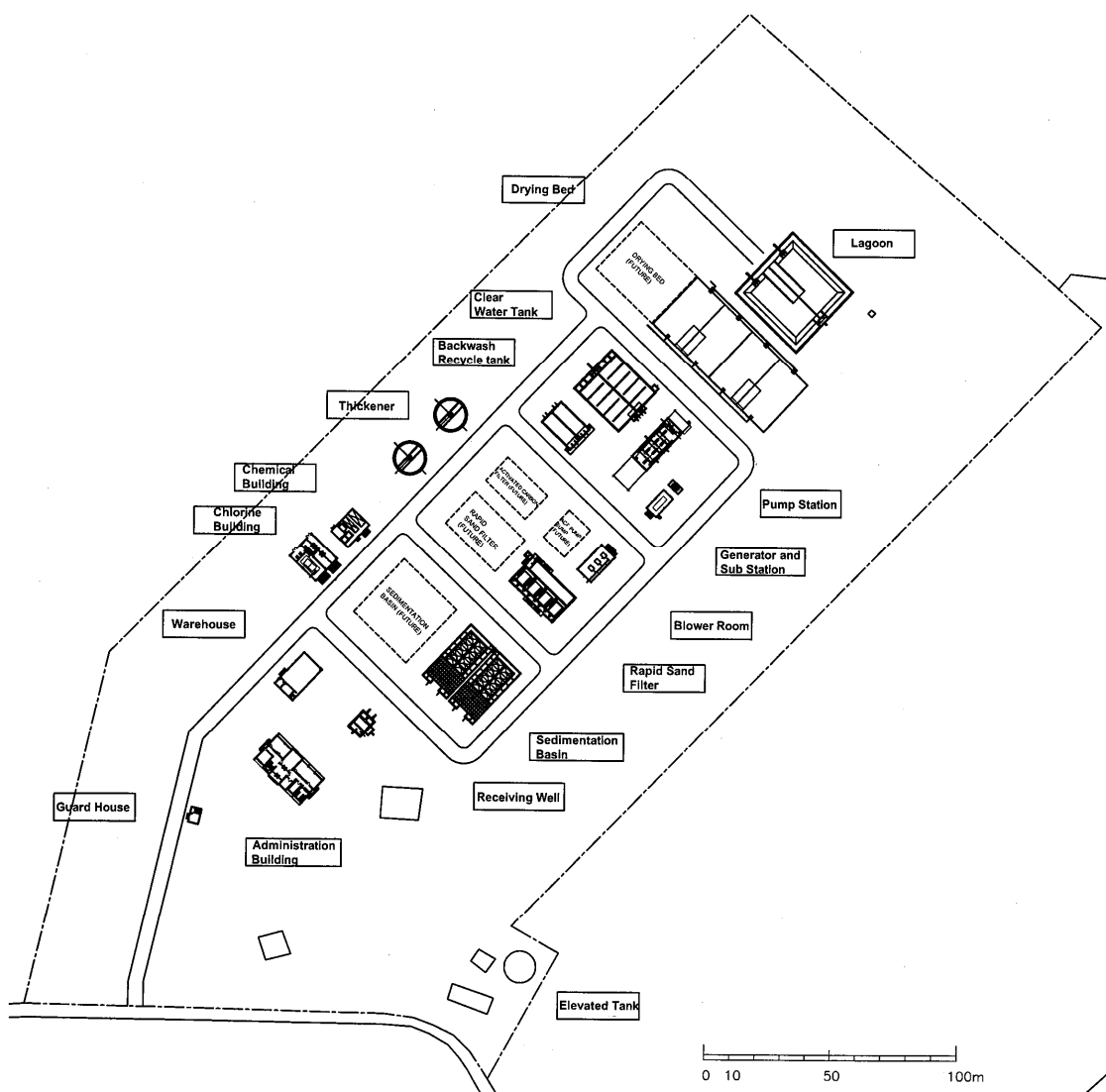

Figure 5.6 Layout of Wahalkada WTP

(3) Outline of Wahalkada WTP

Wahalkada WTP takes water from an irrigation canal from Wahalkada Tank at approximately 420 m downstream from Wahalkada Tank. The capacity of the WTP is determined in consideration of water rights, daily maximum water demand and 5% treatment process loss in **Table 5.21**.

Water demand in 2024 is projected to be mostly half of that in 2034 so that major treatment facilities in 2024 such as sedimentation basin and rapid sand filter should be half capacity of the long term plan in 2034 in order to increase operational efficiency, ratio of utilization and the service life of the facilities.

Table 5.10 Capacity of Wahalkada WTP

| Year | Stage-1 (2024) | Stage-2 (2034) | Remarks |
|----------------------------------|----------------|----------------|---------------------------------------|
| Water rights (m3/d) | —* | 28,800 | |
| Water demand (day ave.) (m3/d) | 11,098 | 22,392 | According to water demand projection |
| Water demand (day Max.) (m3/d) | 13,300 | 26,900 | day ave. x 1.2 |
| Production capacity of WTP(m3/d) | 13,700 | 27,400 | Output of WTP; Capacity of WTP x 0.95 |
| Capacity of WTP (m3/d) | 14,400 | 28,800 | Input to WTP |

Note: * Water right is set at 10,500 m3/day for 2016 and 28,800 m3/day for 2034 in the MOU between the Irrigation Department and NWSDB. Therefore, it is supposed that an amount of 10,500-28,800 m3/day will be available for the year of 2024.

The treatment process is the same as at Mahakanadarawa WTP, except that an elevated tank is provided to supply water to the neighboring villages. Treated water is pumped to the elevated tank, which is located in the WTP site and also to the served areas through transmission pipelines.

The facilities in Wahalkada WTP are summarized in **Table 5.11**.

Table 5.11 Detail of Wahalkada WTP

| Facility | Stage-1 | Stage-2 | Remarks |
|--|---------------------------------------|---------------------------------------|---------------|
| Receiving Well | W5.6 x L5.0m x H6.0m x 1unit | - | * |
| Distribution Chamber | W2.5 x L2.0m x H5.0m x 2units | - | * |
| Flocculator tank | 7stages x89.3m ³ x 4 units | 7stages x89.3m ³ x 4 units | |
| Sedimentation tank | W4.0m x L14.4m x H4.0m x 4units | W4.0m x L14.4m x H4.0m x 4unit | Plate settler |
| Rapid sand filter tank | W4.0m x L6.0m x 4units | W4.0m x L6.0m x 4units | |
| ACF sump | W10.0m x L14.0m x H3.0m x 1unit | | future |
| ACF tank | W3.5m x L5.0m x 4units | | future |
| Chlorine Mixing Chamber | W2.0m x L6.75m x H4.0m x 2units | - | * |
| Reservoir | W10.0m x L21.0m x H4.0m x 2units | - | * |
| Backwash water recycle tank | W5.0m x L15.0m x H4.0m x 2units | - | * |
| Thickener | Dia 12.5m x H4.0m x 1unit | Dia 12.5m x H4.0m x 1unit | |
| Drying bed | W15.0m x L25.0m x H1.0m x 4units | W15.0m x L25.0m x H1.0m x 2units | |
| Lagoon | W12.0m x 25.0m x 1.5m x 1unit | - | * |
| Administration Bldg. | W12.0m x L25m x 2 stories | - | * |
| Chemical house | W11.5m x L12.0m | - | * |
| Chlorine House including neutralization facilities | W12.0m x L14.0m | - | * |
| Pump House | W8.0m x L35.0m | - | * |
| Blower House | W7.3m x L13.5m | - | * |

| Facility | Stage-1 | Strage-2 | Remarks |
|------------------------|---------------------------------------|---------------------------------------|---------------|
| Receiving Well | W5.6 x L5.0m x H6.0m x 1unit | - | * |
| Distribution Chamber | W2.5 x L2.0m x H5.0m x 2units | - | * |
| Flocculator tank | 7stages x89.3m ³ x 4 units | 7stages x89.3m ³ x 4 units | |
| Sedimentation tank | W4.0m x L14.4m x H4.0m x 4units | W4.0m x L14.4m x H4.0m x 4unit | Plate settler |
| Rapid sand filter tank | W4.0m x L6.0m x 4units | W4.0m x L6.0m x 4units | |
| Generator House | W5.0m x L9.5m | - | * |
| Ware House | W10.0m x L17.0m | - | * |

*The capacity of the facilities constructed in Stage-1 includes the whole capacity required for the Project up to Stage-2.

5.3 Transmission and Distribution System

5.3.1 Description of Project Area

The project area is comprised of six DSDs, which are further divided into 194 GNDs covering an area of about 2,863 km². The six DSDs are Padaviya, Kebithigollewa, Medawachchiya, Rambewa, Horowpothana and Kahatagasdigiliya. The population in the project area is estimated to be 204,700 in 2012, which indicates a low population density at less than 1 person/ha on the average.

There are several main roads of route A and B in the project area as shown in **Figure 5.7**. There are four Route A roads and seven Route B roads. The core areas (urban center) are formed with multiple DSDs at six locations as shown in **Figure 5.7**. These core areas are located at the intersection or intersections of the above-mentioned main roads as the development centers of the project area, including Bogahawewa in Padaviya DSD, Kebithigollewa in Kebithigollewa DSD, Medawachchiya in Medawachchiya DSD, Rambewa in Rambewa DSD, Horowpothana in Horowpothana DSD and Kahatagasdigiliya in Kahatagasdigiliya DSD. Villages are sparsely located along the main roads or inland from such roads in each GND. The project area is covered in forests, paddy lands, artificial lakes (tanks) and other vacant lands. The villages are located, in general, beside or near the tank (reservoir) and paddy fields. The road network is also limited in these areas.

Ground elevations in the project area vary widely from +30m up to +150m. The local topography is not necessarily flat, but sometimes fluctuates considerably within GNDs.

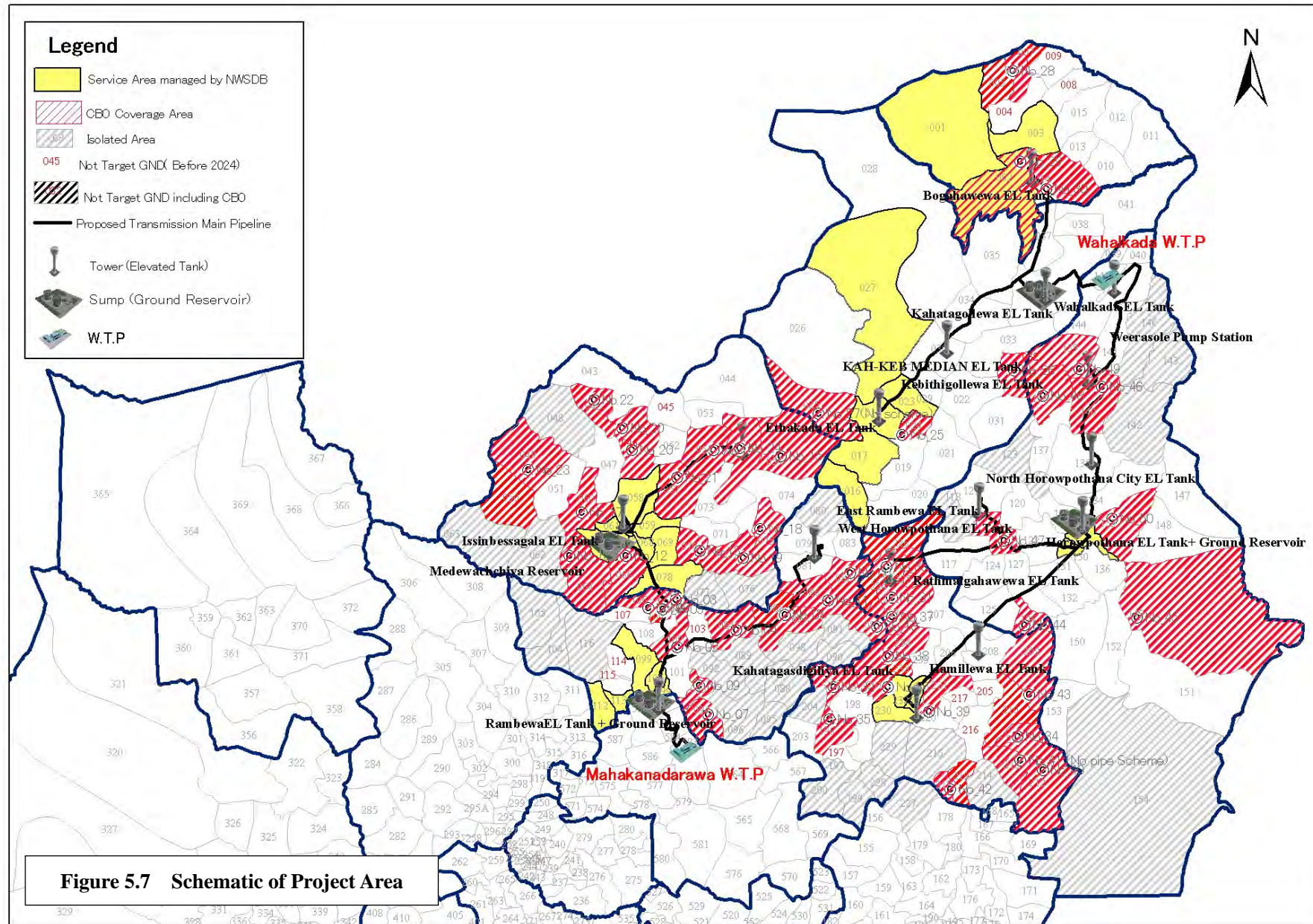

5.3.2 Planning Concept of the System

(1) Transmission System

There are six NWSDB's systems and 50 existing community water supply systems (CBO and CWSSP) in the project area. The NWSDB systems, covering 25 GNDs, are located in the core area(s). Generally, each CBO covers a part of a GND. Some CBOs, however, cover multiple GNDs or two to three GNDs. New water supply systems for GNDs other than the existing CBOs will be constructed under this project. However some of the GNDs will not have piped supply systems, but will be supplied from an indirect system to which water will be transferred by water tankers (Bowers). All the existing CBOs receive treated water at their elevated tanks except for three (3) CBOs as mentioned in **Section 4.2.5**. They are CBO 20 (GND 46), CBO26 (GND 32) and CBO 47 (GND 119)

The number of GNDs presently supplied by NWSDB, existing CBO or new system established under the present project is summarized as follows:

Table 5.12 Summary of GNDs in Project Area

| DSD | GNDs currently supplied by NWSDB | GNDs currently supplied by CBOs | GNDs supplied by new water supply systems | | GNDs receiving bowser delivery water supply | |
|------------------------|----------------------------------|---------------------------------|---|-----------|---|-----------|
| | | | Year 2024 | Year 2034 | Year 2024 | Year 2034 |
| Padaviya ¹⁾ | 3 | 4 | 5 | 8 | 4 | 1 |
| Kebithigollewa | 5 | 2 | 17 | 17 | 1 | 1 |
| Medawachchiya | 8 | 13 | 8 | 9 | 6 | 5 |
| Rambewa | 4 | 12 | 6 | 10 | 16 | 12 |
| Horowpothana | 2 | 6 | 21 | 21 | 8 | 8 |
| Kahatagasdigiya | 3 | 18 | 7 | 11 | 12 | 8 |
| Total | 25 | 55 | 64 | 76 | 47 | 35 |

Note ¹⁾: GND 2 of Padaviya DSD is supplied from both NWSDB and existing CBO (29)

Figure 5.8 shows such GNDs supplied by the existing piped system, new system and indirect supply.

Two water sources are selected for the present integrated water supply system in the northern and southern parts of the project area, namely Wahalkada Wewa and Mahakanadarawa Wewa respectively, from where raw water is conveyed, after treatment, to the entire project area through two transmission systems.

The transmission system from the Mahakanadarawa Wewa is named as the Mahakanadarawa System, which will cover DSDs of Medawachchiya and Rambewa. The Wahalkada system from Wahalkada Wewa transmits treated water to the DSDs of Padaviya, Kebithigollewa,

Horowpothana and Kahatagasdigiliya.

From the demand projection for the year of 2034, the transmission capacity for the Mahakanadarawa and Wahalkada systems is determined as 17,300 m³/day and 26,900 m³/day respectively.

Each transmission system is composed of a transmission main system and a sub-main system. The main system is formed to cover the entire supply zone from the respective water treatment plant and the sub-system supplements the main system to convey bulk water to the elevated tanks, which are placed at strategic locations to distribute water to the new system of GNDs and transmit bulk water to the existing CBOs.

The transmission main system is composed of transmission mains and service centers where a pumping station and an elevated tank are provided. In addition, booster pump stations are provided at strategic locations. The transmission main route of each system is, in general, selected to run along the main roads mentioned above, from the water treatment plant and between service centers. Elevated tanks are provided at key locations to distribute treated water directly to the new distribution systems of GNDs. On the other hand, the existing systems will receive bulk water from the transmission system at the elevated tanks.

Fifteen elevated tanks, four in the Mahakanadarawa system and 11 in the Wahalkada system, are strategically positioned to cover the entire service area. **Table 5.13** shows the area covered by each elevated tank.

Table 5.13 Covering Area of Elevated Tanks

| Transmission System | Elevated Tank | Covering area (ha) |
|-----------------------|------------------------------|--------------------|
| Mahakanadarawa System | I-1 ET (Rambewa) | 6,387 |
| | I-2 ET (Issinbassagala) | 22,333 |
| | I-3 ET (Ethakada) | 13,269 |
| | I-4 ET (East Rambewa) | 2,590 |
| Wahalkada System | II-1 ET (Wahalkada) | 8,545 |
| | II-2 ET (Kahatagollewa) | 7,979 |
| | II-3 ET (Bogahawewa) | 24,252 |
| | II-4 ET (KAH-KEB Median) | 6,839 |
| | II-5 ET (Kebithigollewa) | 37,952 |
| | II-6 ET (North Horowpothana) | 4,408 |
| | II-7 ET (Horowpothana) | 8,522 |
| | II-8 ET (West Horowpothana) | 5,782 |
| | II-9 ET (Rathmalgahawewa) | 5,571 |
| | II-10 ET (Hamillewa) | 26,695 |
| | II-11 ET (Kahatagasdigiliya) | 12,244 |

It is noted that transmission to some of the CBOs, which are remotely located from the transmission main at high ground elevation, will need to be boosted to the level of their respective elevated tanks as shown in **Figure 5.26** for the Mahakanadarawa system and **Figure 5.27** for the Wahalkada system.

(2) Distribution System

There are two systems of distribution, one is the system for the existing CBO systems operated independently by individual CBOs, and the other is the new system for GNDs operated under NWSDB.

The existing CBO's system will receive bulk water from the transmission system operated by NWSDB, and distribute water through the existing distribution network. The new system of the GND will be directly distributed from the elevated tank constructed under the project, and the entire system will be operated by NWSDB. The service area of the existing system under NWSDB will receive bulk water also from the transmission system at the elevated tank and distribute water to its distribution network. In accordance due to the increase in demand, the existing service area will be reduced to meet the capacity of the existing distribution system including the existing elevated tank. The remaining area after reduction of its service area will be covered by the new distribution system constructed under this project.

The CBO is assumed to continue to operate and manage the existing system only. On the other hand, the expansion of service area of CBO due to demand increase is assumed to be handled as

NWSDB considers appropriate.

5.3.3 Design Criteria

(1) Selection of Pipe Materials

Pipe materials to be applied for transmission and distribution pipelines are examined in accordance with the characteristics of pipe materials, locations where they will be installed, and economy of construction.

The recommended pipe materials are summarized as follows:

| | |
|--|---|
| Transmission Main: | PE considering importance as main facility for transmission system, low roughness of internal surface, which reduces friction loss for transmission and economy for applied range of pipe sizes, in comparison with DIP and SP. It is noted, however, that care shall be taken for pipe installation, especially in rocky soil conditions and where there are traffic loads. Sand bed and backfill up to above the crown of the pipe shall be provided. |
| Transmission Sub-main/ Distribution Main: | PE for the same reasons as above. |
| Distribution Sub-system: | PVC considering the small size of pipelines, limited external loads and economy of construction. |
| Special construction: | SP or DIP will be used for crossing works such as major roads, river crossings by pipe bridges and inverted siphon depending on the site conditions and method of crossings. |

(2) Transmission Hydraulics (Key Ground Elevation)

Transmission mains are planned between the water treatment plant and the service centers by pumping. The ground elevations at such sites for the construction of the major facilities are important to determine the size of the transmission main and the dimensions of the pump facilities. Based on the topographical and line surveys, the key ground elevations are determined as shown in **Table 5.14**.

Table 5.14 Key Ground Elevation of Transmission System

| Transmission System | Pump Station / Main Elevated Tank | Ground Elevation (m) |
|-----------------------|---|----------------------|
| Mahakanadarawa System | Water Treatment Plant I (Mahakanadarawa WTP) | + 91.0 |
| | Pump Station I-1 PS / Elevated Tank I-1 ET (Rambewa) | + 89.5 |
| | Pump Station I-2 PS (Medawachchiya) | + 100.0 |
| | Elevated Tank I-2 ET (Issinbassagala) | + 113.0 |
| | Elevated Tank I-3 ET (Ethakada) | + 121.0 |
| | Elevated Tank I-4 East Rambewa | + 112.0 |
| Wahalkada System | Water Treatment Plant II, Elevated Tank II-1 ET (Wahalkada WTP) | + 61.0 |
| | Pump Station II-1 PS / Elevated Tank II-2 ET (Kahatagollewa) | + 68.0 |
| | Elevated Tank II-3 ET (Bogahawewa) | + 66.0 |
| | Elevated Tank II-4 (KAH-KEB Median) | + 94.5 |
| | Pump Station II-2 PS, Elevated Tank II-5 ET (Kebithigollewa) | + 122.0 |
| | Pump Station II-3 PS (Weerasole) | + 57.0 |
| | Elevated Tank II-6 (North Horowpothana) | + 86.0 |
| | Pump Station II-4 PS / Elevated Tank II-7 ET (Horowpothana) | + 73.5 |
| | Elevated Tank II-8 ET (West Horowpothana) | + 116.0 |
| | Elevated Tank II-9 ET (Rathmalgahawewa) | + 122.0 |
| | Elevated Tank II-10 ET (Hamillewa) | + 101.7 |
| | Pump Station II-5 PS / Elevated Tank II-11 (Kahatagasdigiliya) | + 146.0 |

5.3.4 Mahakanadarawa System

A schematic flow diagram of the Mahakanadarawa System is shown on **Figure 5.9**.

The Mahakanadarawa system for transmission main is composed of four (4) sections as shown on **Table 5.15**.

Table 5.15 Mahakanadarawa Transmission System

| Span | | Route | Dia. (mm) | Length (km) |
|------|---|---------------------|-----------|-------------|
| 1 | Mahakanadarawa WTP~Rambewa Service Centre | Local road | 450 | 7.1 |
| 2 | Rambewa Service Centre~Medawachchiya PS | Route A9 | 450 / 400 | 15.8 |
| 3 | Medawachchiya PS~Issinbassagala Elevated Tank | Route A9/A14 Bypass | 350 | 3.1 |
| 4 | Medawachchiya PS~Ethakada Elevated Tank | Route B211 | 300 / 250 | 14.4 |

I. MAHAKANADAWARA TRANSMISSION SYSTEM FLOW DIAGLAM

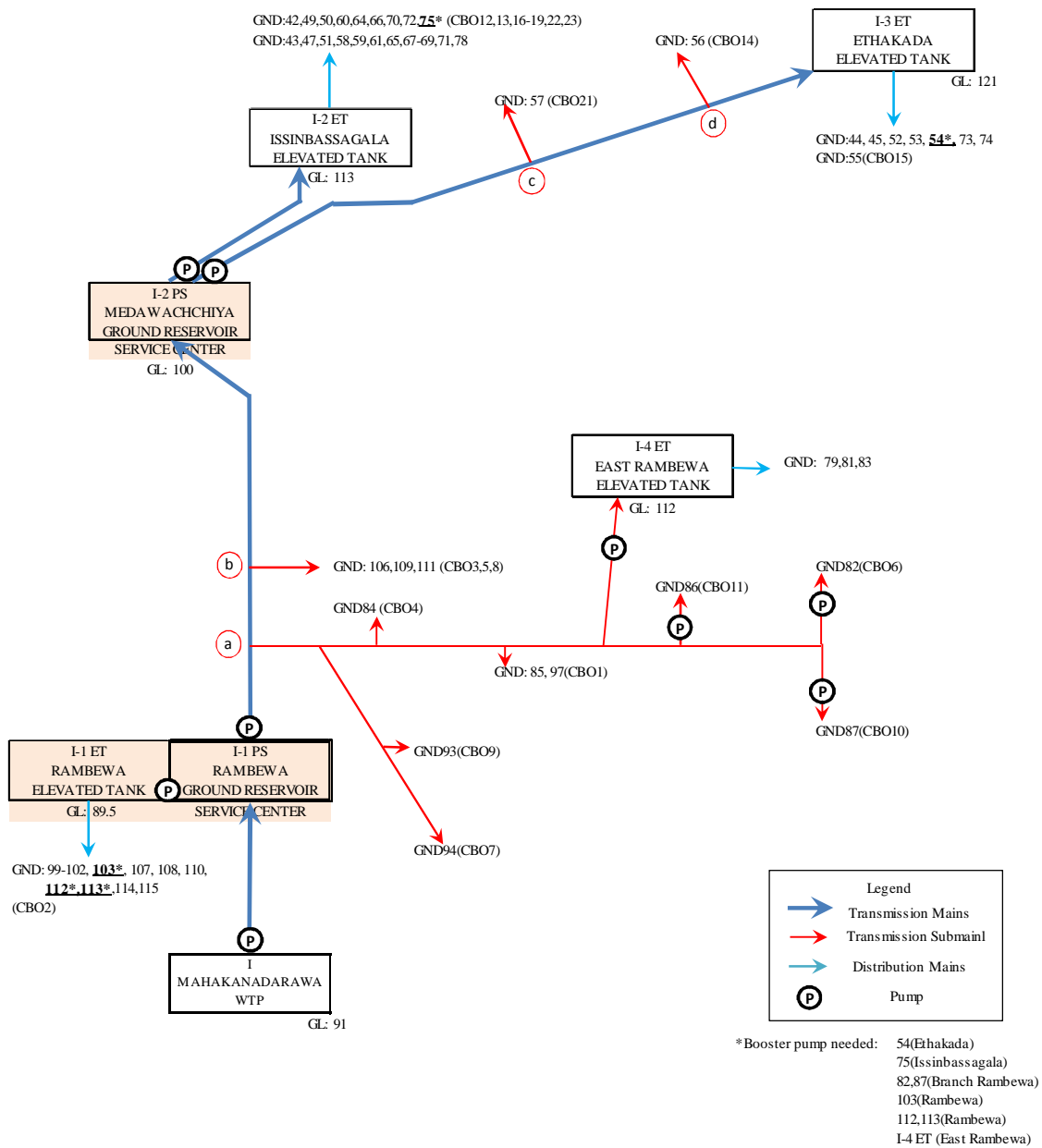

Figure 5.9 Schematic Flow Diagram of the Mahakanadarawa System

5.3.5 Wahalkada System

The Wahalkada System is further divided into two sub-systems to cover northern part and Southern part of its service area. The former is named as Wahalkada Sub-system IIA and the latter as Wahalkada Sub-system IIB.

A schematic flow diagram of the Wahalkada System is shown in **Figure 5.10**.

Table 5.16 Wahalkada Transmission System

| Span | | Route | Dia. (mm) | Length (km) |
|-----------------------------|--|------------|-----------|-------------|
| Wahalkada System IIA | | | | |
| 1 | Wahalkada WTP ~ Kahatagollewa PS | Local road | 400 | 7.8 |
| 2 | Kahatagollewa PS ~ Bogahawewa Elevated Tank | Route B211 | 350 | 12.0 |
| 3 | Kahatagollewa PS ~ Kebithigollewa Service Centre | Route B211 | 350 | 20.1 |
| Wahalkada System IIB | | | | |
| 1 | Wahalkada WTP ~ Weerasole PS | Local road | 450 | 14.7 |
| | Weerasole PS ~ Horowpothana Service Centre | Local road | 450 | 15.5 |
| 2 | Horowpothana Service Centre ~ Kahatagasdigiya Service Centre | Route A12 | 450 | 22.4 |
| 3 | Horowpothana Service Centre ~ Rathmalgahawewa Elevated Tank | Route B282 | 300 | 19.2 |

II. WAHALKADA TRANSMISSION SYSTEM FLOW DIAGRAM

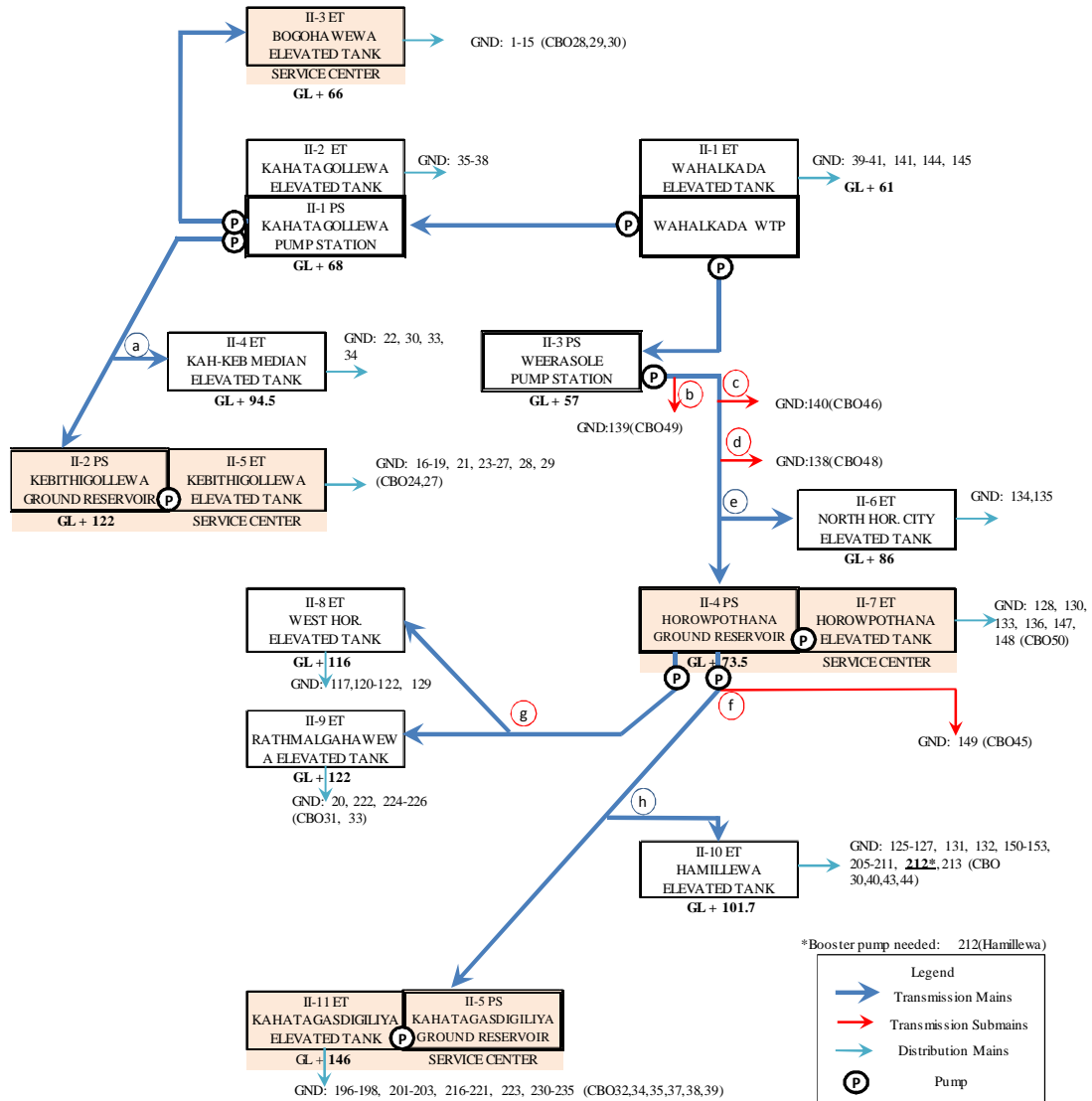

Figure 5.10 Schematic Flow Diagram of the Wahalkada System

5.3.6 Distribution System

(1) Method of Estimate

Distribution system, as mentioned earlier, is composed of distribution main and distribution sub-system. **Figure 5.11** illustrates definitive plan of the distribution system.

As shown on **Figure 5.11**, distribution main conveys water from the elevated tank directly to the GND's distribution sub-system which distributes water to each customer directly. On the other hand, the main feeds water to the existing elevated tank of CBO, from where distribution sub-system distributes water to each customer. In both cases, a water meter will be installed at the inlet of either distribution sub-system of new system of GND or existing elevated tank of CBO.

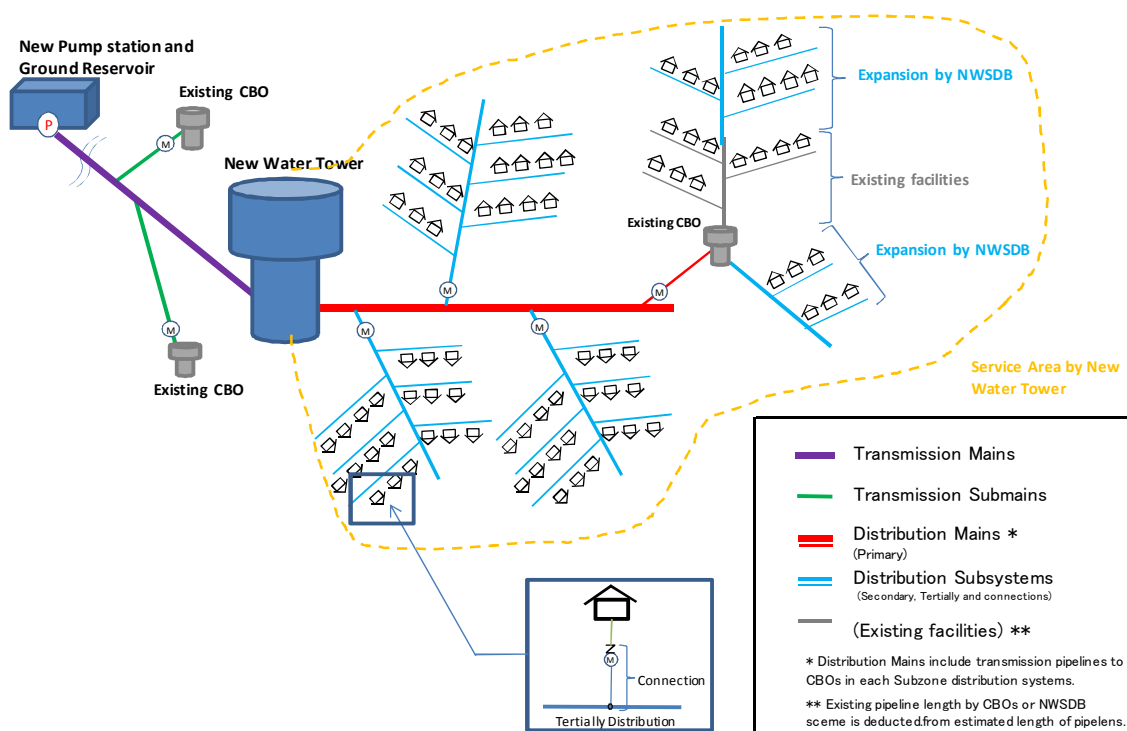

Figure 5.11 Definitive Diagram of Distribution Systems

1) Distribution Main

The preliminary design of distribution main is carried out using Google map to obtain distance and ground elevation for analysis of sizing of distribution main for the purpose of cost estimate.

Appendix 5.3 (b) presents general layout of the distribution main for each subzone (11 subzones from elevated tanks) and hydraulic analysis

2) Distribution Sub-system (Refer to **Appendix 5.3 (c)**)

The study on distribution sub-system is carried out mainly for cost estimate purpose based on the following procedures:

- Firstly, select three networks (small, medium and large systems) designed by the existing CBO system. The system capacities of the above systems are 100m³/day as small system, 150m³/day as medium system and 300m³/day as large system.
- Secondly, determine the scale of the distribution systems of 150m³/day for small system, 300m³/day for medium system and 600m³/day for large system as day average demand in 2034.
- Then, by enlarging existing system in length and node discharge in proportion to demand difference, the network model was established. Using the above network model, network analysis was carried out to obtain size and pipeline length.
- Finally, unit length of each size of distribution pipe per service connection was analyzed to obtain pipeline length by size for respective size of network.
- Using above unit length, pipeline length of each size were estimated by GND.

(2) Pipeline length

1) Distribution Main

The sizing of distribution main was determined peak hour demand of year 2034 requirement for new system of GND and day maximum demand of year 2034 for the existing CBO.

Based on the hydraulic analysis of the distribution main, length of each size of pipeline was obtained as presented in **Table 5.17**.

2) Distribution Sub-system

Using unit length to service connection, the pipeline length for each size was estimated for Phase I (year 2024) based on the following considerations:

- Pipeline lengths of 100mm or larger were estimated for year 2034 requirement
- Pipeline lengths of 50mm and 75mm were estimated for year 2024 requirement corresponding to the construction period.

The results of pipeline length for Phase I requirement are summarized in **Table 5.33** also. It should be noted that the length in the table is for a year 2024 requirement which corresponds to the project implementation period.

5.3.7 Major Facilities of Transmission and Distribution System

The summary of major facilities of transmission and distribution system is presented in **Tables 5.17** and **Tables 5.18** and **Figure 5.12**.

Table 5.17 Summary of Pipelines of Transmission and Distribution System

| Items/ Length of Pipelines (km) | Nominal Diameter (mm) | | | | | | | | | | Total |
|---|-----------------------|--------------|--------------|--------------|--------------|-------------|-------------|-------------|-------------|-------------|---------------|
| | 50 | 75 | 100 | 150 | 200 | 250 | 300 | 350 | 400 | 450 | |
| I. Mahakanadarawa System | | | | | | | | | | | |
| 1) Transmission Mains | - | - | - | - | - | 7.6 | 7.5 | 3.3 | 13.1 | 10.8 | 42.3 |
| 2) Transmission Sub-mains | - | - | 23.0 | 5.9 | 21.6 | 0.3 | - | - | - | - | 50.8 |
| 3) Distribution Mains | - | - | 7.0 | 55.5 | 41.2 | 26.1 | 4.3 | 5.6 | 1.7 | - | 141.4 |
| 4)-1 Distribution Sub-System (NWSDB scheme) | 80.2 | 25.6 | 59.7 | 31.3 | 4.8 | - | - | - | - | - | 201.6 |
| 4)-2 Distribution Sub-System (Existing CBO scheme) | 130.6 | 113.8 | 49.1 | 18.8 | 2.8 | - | - | - | - | - | 315.1 |
| Subtotal* | 210.8 | 139.4 | 138.8 | 111.5 | 70.4 | 34.0 | 11.8 | 8.9 | 14.8 | 10.8 | 751.2 |
| II. Wahalkada System | | | | | | | | | | | |
| 1) Transmission Mains | - | - | - | - | - | - | 20.2 | 33.7 | 20.8 | 42.6 | 117.3 |
| 2) Transmission Sub-mains | - | - | 18.6 | 0.1 | 5.0 | 0.6 | - | - | - | - | 24.3 |
| 3) Distribution Mains | - | - | 46.0 | 138.0 | 72.9 | 43.7 | 11.7 | 9.8 | 4.6 | - | 326.7 |
| 4)-1 Distribution Sub-System (NWSDB scheme) | 148.5 | 63.2 | 127.2 | 32.8 | 6.7 | - | - | - | - | - | 378.4 |
| 4)-2 Distribution Sub-System (Existing CBO scheme) | 102.7 | 75.7 | 48.3 | 23.4 | 4.5 | - | - | - | - | - | 254.6 |
| Subtotal* | 251.2 | 138.9 | 240.1 | 194.3 | 89.1 | 44.3 | 31.9 | 43.5 | 25.4 | 42.6 | 1101.3 |
| Total | 462.0 | 278.3 | 378.9 | 305.8 | 159.5 | 78.3 | 43.7 | 52.4 | 40.2 | 53.4 | 1852.5 |

Note ¹⁾: length of transmission main in the above table includes additional 5% of estimated length that will be allowed when latent site conditions are considered.

²⁾: lengths of transmission sub-main and distribution main in the above table include additional 10% of estimated length that will be allowed since the estimate is based on Google map which is considered as not accurate enough.

³⁾: length of distribution sub-system in the above table includes additional 10% of estimated length that will be allowed since the estimate is based on the plot type design based on network model which is considered not accurate enough











¹⁾⁻³⁾: HDPE, ⁴⁾⁻¹⁻²⁾: PVC

* Subtotal of each items:

1) Transmission Mains: **159.6 km**, 2) Transmission Sub-mains: **75.1 km**, 3) Distribution Mains: **468.1 km**

4) Distribution Sub-System (NWSDB scheme): **580.0 km**, (Existing CBO scheme): **569.7 km**

Table 5.18 Summary Table of the Facilities to Be Constructed

| System | Site | Elevated Tank | Ground Reservoir | Pump House | Operational Complex *1 | Chlorinator Building | Generator | Workshops | Quarters for Staff | Quarters for Operator | Surge Tank (100m ³) |
|-----------------|-------------------------|---|---|---|---|---|--|---|---|---|---|
| Mahakanadarawa | Rambewa | 1,250m ³ | 1,500m ³ | ✓ | ✓ | ✓ | ✓ | | ✓ | ✓ | |
| | Medawachchiya | | 1,000m ³ | ✓ | ✓*2 *3 | ✓ | ✓ | ✓ | ✓ | ✓ | |
| | Issinbassagala | 2,000m ³ | | | | ✓ | | | | ✓ | |
| | Ethakada | 750m ³ | | | | ✓ | | | | ✓ | |
| | East Rambewa | 250m ³ | | | | ✓ | | | | ✓ | |
| | Mahakanadarawa ~Rambewa | | | | | | | | | | ✓✓ |
| Wahalkada South | Wahalkada | 500m ³ | | | | ✓ | | | | ✓ | |
| | Kahatagollewa | 250m ³ | 1,000m ³ | ✓ | | ✓ | ✓ | | | ✓ | |
| | Bogahawewa | 2,000m ³ | | | ✓ | ✓ | | | ✓ | ✓ | |
| | KAH-KEB Median | 250m ³ | | | | ✓ | | | | ✓ | |
| | Kebithigollewa | 750m ³ | 500m ³ | ✓ | ✓*3 | ✓ | ✓ | ✓ | ✓ | ✓ | |
| Wahalkada North | Weerasole | | 1,500m ³ | ✓ | | ✓ | ✓ | | | ✓ | |
| | North Horowpothana | 250m ³ | | | | ✓ | | | | ✓ | ✓ |
| | Horowpothana | 500m ³ | 1,000m ³ | ✓ | ✓*3 | ✓ | ✓ | ✓ | ✓ | ✓ | |
| | West Horowpothana | 750m ³ | | | | ✓ | | | | ✓ | |
| | Rathmalgahawewa | 500m ³ | | | | ✓ | | | | ✓ | |
| | Hamillewa | 1,250m ³ | | | | ✓ | | | | ✓ | |
| | Kahatagasdigilliya | 1,500m ³ | 500m ³ | ✓ | ✓ | ✓ | ✓ | | ✓ | ✓ | |
| Total | | 15 | 7 | 7 | 6 | 17 | 7 | 3 | 6 | 17 | 3 |
| Symbol | |  |  |  |  |  |  |  |  |  |  |

*1 Lab., OICs Office, Customer Counter, Room for Crews

*2 Satellite Office is to be included

*2 OIC Office should be replaced to Area Engineers Office

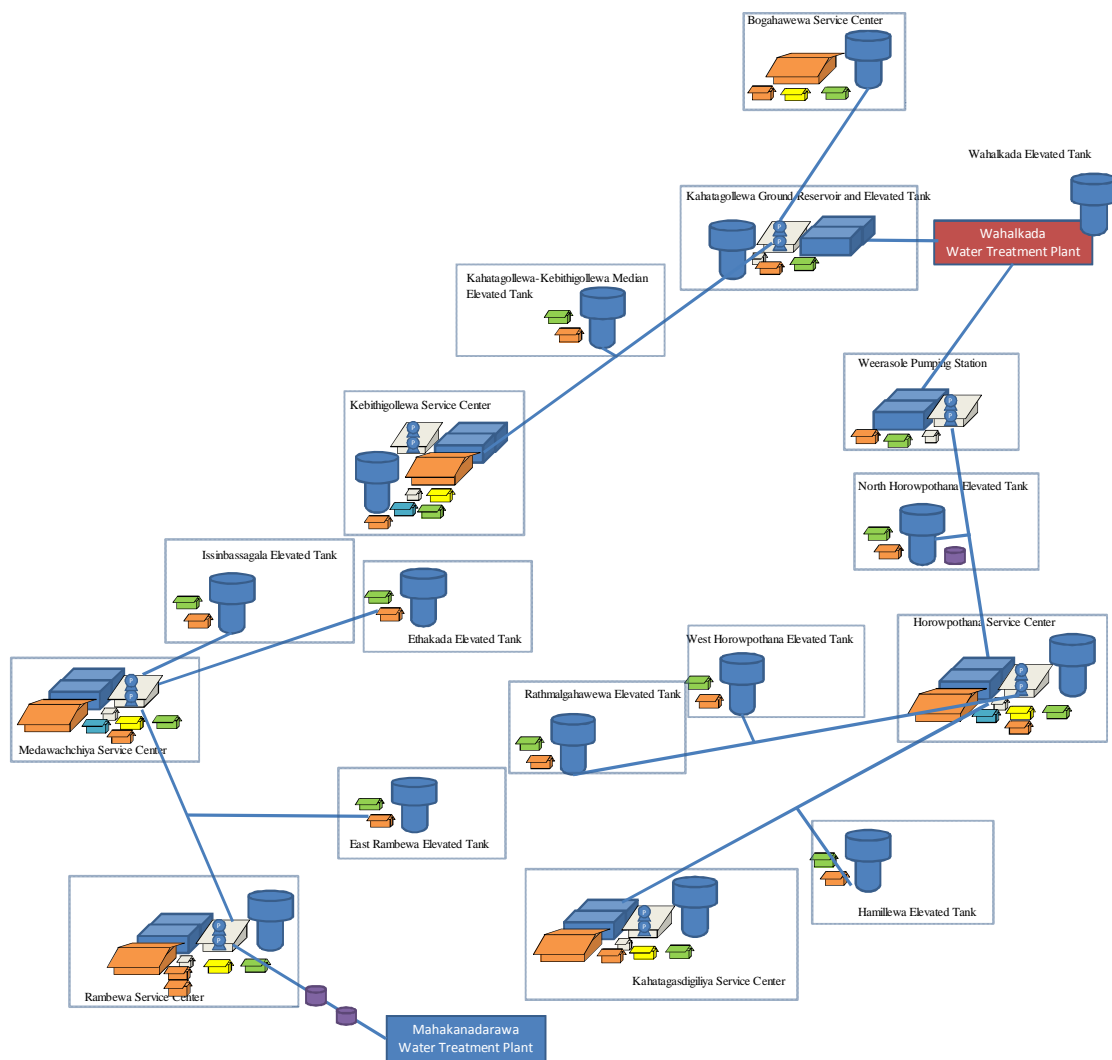

Figure 5.12 Summary Diagram of the Facilities to be Constructed

Table 5.19 Major Facilities of Transmission and Distribution System

| DS Division | Land Location | Facilities to be constructed |
|-------------|---------------|---|
| Rambewa | Rambewa * | Elevated Tank (1,250m ³) Ground Reservoir (1,500m ³) Pump House / Power Control Unit Generator Operational complex — Zonal Lab Operational complex — OIC Sub-office with SCADA monitor Operational complex — Customer Counter Operational complex — Room for crews Chlorinator Building Staff Quarters Caretaker/Operator Quarters Guard House Parking/Bowser Station |
| | East Rambewa | Elevated Tank (250m ³) Chlorinator Building |

| DS Division | Land Location | Facilities to be constructed |
|---------------|-------------------------|--|
| | | Caretaker/Operator Qts |
| | Surge Tank A | One Way Surge Tank (100m3) |
| | Surge Tank B | One Way Surge Tank (100m3) |
| Medawachchiya | Medawachchiya * | Ground Reservoir (1,000m3) Pump House / Power Control Unit Generator Operational complex - Zonal Lab Operational complex - Area Eng. office with SCADA monitor Operational complex - Customer Counter Operational complex - Room for crews Chlorinator Building Workshop Staff Quarters Caretaker/Operator Quarters Guard House Parking/Bowser Station |
| | Issinbassagala | Elevated Tank (2,000m3) Chlorinator building Caretaker/Operator Qts |
| | Ethakada | Elevated Tank (750m3) Chlorinator Building Caretaker/Operator Qts |
| Horowpothana | Wahalkada | Elevated Tank (500m3) |
| | Weerasole | Ground Reservoir (1,500m3) Chlorinator Building Generator Caretaker/Operator Qts Parking/Bowser Station |
| | Horowpothana * | Elevated Tank (500m3) Ground Reservoir (1,000m3) Pump House / Power Control Unit Generator Operational complex -Zonal Lab Operational complex -BCustomer Counter Operational complex — Room for crews Chlorinator Building Workshop Staff Quarters Caretaker/Operator Quarters Guard House Parking/Bowser Station |
| | North Horowpothana City | Elevated Tank (250m3) Chlorinator Building Caretaker/Operator Qts One Way Surge Tank Parking/Bowser Station |
| | West Horowpothana | Elevated Tank (750m3) Chlorinator Building (100m2) x1 Caretaker/Operator Qts (100m2) x1 |
| | Hamillewa | Elevated Tank (1,250m3) Chlorinator Building |

| DS Division | Land Location | Facilities to be constructed |
|-------------------|---------------------|---|
| | | Caretaker/Operator Qts |
| Kahatagasdigiliya | Kahatagasdigiliya * | Elevated Tank (1,500m3) Ground Reservoir (500m3) Pump House / Power Control Unit Generator OIC Sub-office with SCADA monitor / Customer Counter Operational complex - Zonal Lab Operational complex - OIC Sub-office with SCADA monitor Operational complex - Customer Counter Operational complex - Room for crews Chlorinator Building Staff Quarters Caretaker/Operator Quarters Guard House Parking/Bowser Station |
| | Rathmalgahawewa | Elevated Tank (500m3) Chlorinator Building Caretaker/Operator Qts |
| Kebithigollewa | Kebithigollewa * | Elevated Tank (750m3) Ground Reservoir (500m3) Pump House / Power Control Unit Generator Operational complex - Zonal Lab Operational complex - Area Eng. office with SCADA monitor Operational complex - Customer Counter Operational complex - Room for crews Workshop Chlorinator Building Staff Quarters Caretaker/Operator Quarters Guard House Parking/Bowser Station |
| | KEB-KAH Median | Elevated Tank (250m3) Chlorinator Building Caretaker/Operator Quarters |
| | Kahatagollewa | Ground Reservoir (1,000m3) Elevated Tank (250m3) Chlorinator Building Caretaker/Operator Quarters |
| Padaviya | Bogahawewa * | Elevated Tank (2,000m3) Operational complex - Zonal Lab Operational complex - OIC Sub-office with SCADA monitor Operational complex - Customer Counter Operational complex - Room for crews Chlorinator Building Staff Quarters Caretaker/Operator Quarters Guard House Parking/Bowser Station |

* Service Center

5.4 Mechanical Equipment

5.4.1 Design Criteria of Pumping Stations

Design of equipment and the planning of pumping stations are based on criteria issued by NWSDB as shown below, and from the survey results of the existing pump stations.

- (1) Design Manual D5, Mechanical, Electrical and Instrumentation Aspects of Water Supply Design March 1989
- (2) Procurement of Supply and Install Mechanical & Electrical Equipment and Accessories for Water Supply Scheme
- (3) NWSDB/SBD/S&I/Water Pump: Specifications for Horizontal Shaft Driven Double Suction Pumping Sets and Accessories
- (4) NWSDB/SBD/S&I/Water Pump: Specifications for End Suction Vertical Delivery Back Pull out Centrifugal Pumping Sets and Accessories

5.4.2 Planning of Pump Station

The pump stations particularly take the following points into consideration:

- (1) Energy conservation
- (2) Easy operation and maintenance
- (3) Measure of discharging the sand/silt deposit on intake waterways
- (4) Water Hammer

5.4.3 Intake Facility

Water taken from an irrigation canal is conveyed to the pump suction pit by an open channel. In the pump suction pit, it is necessary to lower the bottom from the level of irrigation canal in order to keep air from going into a pump, thus sand/silt is deposited in the pump suction pit. Therefore, a facility which discharges the sand/silt from the pump pit to a sand sedimentation pond is planned. After discharging periodically to the pond by pump, the clear supernatant liquid is returned to the irrigation canal, and the sand/silt which is deposited is removed manually by workers.

5.4.4 Pump

(1) Operation system of pump

1) Control of intake pump

Intake pump stations are built in or near the site of the water treatment plant, and operation is

performed from the administration building of the plant. Since the change in water supply demand from when operation will start in 2018 to the target year of 2034, or roughly in the range of 25% (of the 2034 demand) to 100%, the pumps need to operate efficiently, corresponding to the change in demand. Therefore, an operating system that the pump speed is adjusted according to the change in water demand, which is more effective than operation method of pump number and valve control, is adopted. Speed control (VVF system) equipment is equipped in each pump panel, and the pump speed is determined according to the required amount of water from the administration building of the water treatment plant.

2) Control of transmitting pump with a motor rating of 15kW or more

Although the number control of pumps is carried out at the existing pump station, looking at the water level of the transmitted tank, the power loss becomes large. Therefore, speed control which can smoothly supply water of the required amount to suit the demand is adopted.

Operation of pumps is carried out using a system which adjusts the speed manually, based on the water level signal from the water tank, which is the same method as is used for existing pumps. A water level meter is installed in each water tank and the SCADA system sends the water level signal to the pump station as discussed in Clause 5.5.

3) Control of transmitting pump with a motor rating of 11kW or less.

For the pump with motor rating such as 11kW or less, the number control of pumps by discharge water levels is selected for that the energy-conservation advantage is small.

(2) The number of pumps

It is desirable to select a number pumps (4) because the water demand will increase from 25% (of 2034 demand) in 2018 to 100% in 2034. However, since the speed control system is used, it is possible to reduce the number of pumps.

All essential pump systems include one standby pump/motor set to provide.

(3) Type of pump and materials

The horizontal pump, which has easier maintenance than a vertical pump, is selected. For that purpose, the pump stations and water tanks are separated from each other.

The pump speed is selected as 1500 min^{-1} from the standard pump range because of higher efficiency compared to high-speed pumps operating at 3000 min^{-1} .

The materials of the main parts of a pump are as follows, taking into consideration the possibility of corrosion by chlorine.

- | | |
|-----------------|---------------------------|
| 1) Pump shaft | : Stainless Steel |
| 2) Impeller | : Stainless Steel Casting |
| 3) Casing | : Cast Iron |
| 4) Shaft Sleeve | : Stainless Steel |

5.4.5 Electric Motor

(1) Type of electric motor

The electric motor is directly coupled with the pump, and the specification of the motor is according to the requirements of “NWSDB/SBD/S&I/Water Pump”.

5.4.6 Other Equipment

The following equipment is installed in each pump station.

- (1) Overhead traveling crane
- (2) Flow control valve
- (3) Valves for suction and discharge of pump
- (4) Indoor piping
- (5) Drain pumps in pump room

5.4.7 Measures against Water Hammer

The general features of the different surge protection measures are shown in **Table 5.20**.

Table 5.20 Comparison of Measure System

| Measure system | General feature |
|---------------------------|--|
| One-way Surge tank system | Although it is a simple method, the installation space is needed on the pipeline, and in order that the setting position may be left distantly from the pump station. There is a fault that maintenance management is difficult. |
| Surge vessel system | It is not suitable for the pipeline form such as passing the mountain, flat and going-down slope. It is expensive, and it is not easy to maintain because this system consists of many equipment and instruments. In case of bladder accumulator type, the selection which meets actual requirements such as size, gas volume and pressure is difficult. |
| Flywheel method | Maintenance management is very easy and reliable, and it is economical. The effect is almost the same as surge vessel system. |
| Air valve | When negative pressure arises in pipeline by down surge, it is the simplest system that puts air in a pipe and relieves negative pressure. However, if a pump is again started in the condition where air remains in pipe, there is a danger of air hammer generating. The reliability of the functional maintenance is very low. |

It is judged from the above table that the flywheel method is the most appropriate system and this is adopted. The main reasons for this are easy maintenance management and cost saving. However, if negative pressure cannot be prevented by using the flywheel system only, in cases such as pipelines passing over a mountain, the one-way surge tank is installed at the high point of the pipeline.

5.5 Electrical Equipment

5.5.1 Electricity Power Supply

In Sri Lanka, electricity power generating, transmission, and distribution are managed by Ceylon Electricity Board (hereinafter: CEB). No grid-station of CEB is furnished in North Central of Anuradhapura area, and 33 kV power transmission lines are supplied by overhead lines from Anuradhapura grid-stations.

The power distribution to water supply facilities will be classified into the categories mentioned below by CEB. In these categories, Low voltage means three-phase four lines 50Hz 440/230V while Medium voltage means three-phase three lines 50Hz 11/33kV. In this project, 33kV will be applied.

Category I-1: This category shall apply to the consumers who require 400/230 nominal voltage at individual incoming point and whose power demand is less than or equal to 42kVA. If there is an existing transformer supplied by CEB close to the incoming point (within 400m), the consumer will not have to bear the installation cost. But if not, the consumer will be required to install a new transformer and bear a half of installation cost.

Category I-2: This category shall apply to the consumers who require 400/230 nominal voltage at individual incoming point and whose power demand exceeds 42kVA. In case the power demand exceeds 42kVA and up to 63kVA, incoming medium voltage line and power transformer shall be installed by CEB and fifty percent of the installation cost shall be owned by consumer. In case the power demand exceeds 63kVA, full of those costs shall be borne by consumer. Concerning metering, over 42kVA up to 1MVA, kilo watt-hour will be measured at the secondary side of transformer by CEB metering device, and exceeding 1MVA, primary side of transformer will be measured by it. No upper limitation is set for this contract demand.

Category I-3: This category shall apply to the consumers who require 11/33kV at individual incoming point. In this case, power receiving facility shall be constructed by the customer and power receiving capacity will have no limitation except for the lower side limitation, 1 MVA.

However, the construction cost of power receiving facility will be expensive because the power distribution voltage applied in the North Central area is 33kV. So it is not suggested to apply this category I-3 even if the power rate is lower than Category I-2 by 0.2 rupees per kilo watt-hour., except for the facility including high-voltage motors.

Elevated tanks and GND Transmission pump stations, which have no main power loads other than Chlorination booster pumps, will be applied General Purpose (GP-1). Other facilities such as water treatment plants and ground water reservoirs will be applied Category I-1 or Category I-2 mentioned above. So, all facilities except for elevated tank sites and GND Transmission Pump sites will be applied Category I-2. In the case of Category I-2, housing for the power measurement panel will be installed and owned by customer based on the CEB standard drawings.

According to the comments of CEB, there is no actual example of double power incoming system so there is no choice but to install single power incoming system for all medium voltage receiving facilities.

Electricity rate discount based on power factor correction is not set up in the tariff. On the other hand, demand rate will be discounted corresponding to the power factor correction since the rate is determined by kVA. On this design, static capacitor for power factor correction will not be applied because of using VSD (Variable Speed Driver) for all transmission pumps, while it is described to install static capacitor to the loads whose capacity is more than 25kW to improve the power factor from 85% to 95% on the Specifications for Horizontal Shaft Driven Double Suction Pumping Sets and Accessories (here in after: NWSDB Specifications). The installation cost for 33kV medium voltage distribution line is 2.4MRs per 1km, and this cost is increasing year by year as reported by CEB.

5.5.2 Power Generator

Electricity power reliability at the North Central Area is low. Diesel engine generator for the emergency is indispensable to supply water steadily as during times of blackout time. The continuing time of power failure is expected to be a long time. So, the storage volume of fuel tank will be designed for twenty-four hours use so as to be able to fill the gap when the fuel storage comes low. The fuel tank will be basically installed outside.

Considering the high frequency of power failure and request from NWSDB, installation of stand-by generator will be imperative.

According to environmental recommendation from the Central Environmental Authority for the Water Treatment Plant at Wahalkada Proposed by NWSDB, noise regulation of proposed area requires less than 45 dB at night at the boundary of the proposed site and surrounding area. In principle, enclosed sound attenuated type stand-by generators can be planned to comply with the regulation.

As a most commonly used type, diesel generator will be applied for this project.

No generators will be installed at the facility only for an elevated tank. Standby power supply for instrumentation and monitoring equipment at the elevated tanks, such as level meters and wireless communication devices for SCADA, will be backed up by UPS for approximately 30 minutes.

As same as transformer, these generators will also cover the ultimate phase power demand from the beginning.

5.5.3 Low Voltage Facilities

As for motor starters, standards requirement is mentioned in detail in the specification of NWSDB. This proposal will comply with the specification as follow.

MCC will be composed following items.

- 1) Panel enclosures
- 2) Bus-bars with MCCB's (Distribution section)
- 3) Supply incoming section
- 4) Small power distribution section
- 5) Motor starting sections
- 6) Automatic controllers & indicators
- 7) Cabling

5.5.4 Instrumentation Facilities

Flow meters, level meters and pressure meters will be installed in this project to monitor the quantitative parameters.

As for qualitative parameters, there are turbidity, pH, temperature, chlorine ion concentration, color, conductivity and alkalinity of raw water, chlorine ion concentration at the discharge of filter, turbidity and residual chlorine of the effluent required to be monitored in general. Considering the lifetime of automatic measuring instrument, which is generally short, and difficulty of troubleshooting at site, water quality as mentioned above will be manually analyzed in a water testing laboratory by means of drawing sampling water from each section.

Surge arrester will be installed to both transmitter and receiver to prevent from lightning surge since it frequently thunders in Sri Lanka.

5.5.5 Monitor and Control Facilities

(1) Central monitoring and control system

SCADA (Supervisory Control And Data Acquisition) will be installed as the most proven central monitoring system in Sri Lanka.

The water supply system proposed in this project comprises Makahanadarawa network and Wahalkada network. The SCADA will be designed to cover each network systematically which will contain a water treatment plant, transmission and distribution pipelines.

Two LCD monitoring devices and two printers for logging and alarming compose central monitoring system. The two LCD devices shall be configured as dual redundant system, one primary and the other hot-standby, so that the standby one can take over the primary one in case of the failure occurred in the primary one without interruption to the plant operation.

(2) Water transmission and distribution system monitoring

There are three communication network systems which have been more installed recently because of their inexpensiveness than existing telemeter system as a remote monitoring communication system. The first one is wireless communication system using UHF, the second one is VPN communication system combining the technology of the existing telephone line (ADSL) and the internet. And the third one is GPRS communication system utilizing the packet communication of the GSM network.

The GPRS system is relatively reasonable to use and applied worldwide. Considering the fact that existing elevated tanks in Anuradhapura area also utilize it, GPRS system will be proposed in this project.

The study team conformed to the supplier who has the experience to install GRPS system in Kandy project, the transmission condition of GRPS in North Central area.

NWSDB specification mentioned automatic control should not be installed when utilizing GPRS system. According to the specification, the engineers for monitoring will need to stay at site on 24 hours basis and manually operate pumps monitoring the water level of elevated tank.

To make the operation easier, LCD device to monitor water level of each elevated tank will be installed at the ground reservoir which has pumps to transmit the water to two or more elevated tanks or ground reservoir. The LCD device has the function to alarm operators by making a phone call to or mailing to.

At the elevated tanks, a float type valve will be installed to avoid overflow. To prevent the pumps from continuously operating when the float valve is closed, the pumps will be automatically

stopped with an interlock by detecting the combination signals of non-flow from a flow meter and transmission high pressure from a pressure switch. Obviously, an interlock will be also required to stop the pumps when the water level is below the minimum level.

5.6 Water Supply System for Isolated Areas

The Project is to integrate the existing small-scale water supply systems into two large-scale ones. The following priority of factors is considered to select service areas of two pipe borne water supply systems.

- 1st GNDs with an existing water supply system
- 2nd GNDs where the facilities of a proposed water supply system are included
- 3rd GNDs covering a urban centre including its surrounding GNDs
- 4th GNDs along with main roads designated

As the result of analysis, the remaining areas are categorized as isolated areas. The population is 53,500 for isolated areas, 225,000 for non-isolated areas and 278,500 in total for the target year of 2034, respectively.

Figure 5.13 shows the concept of water supply system in the isolated area.

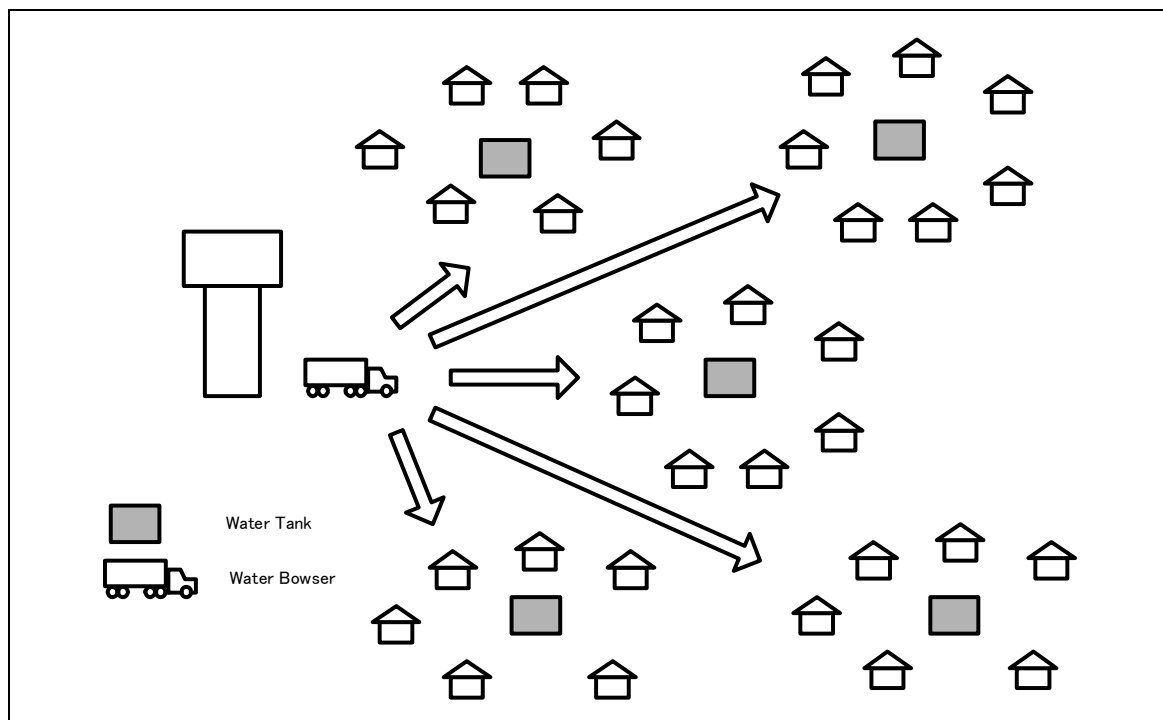

Figure 5.13 Water Supply System in Isolated Area

The water supply system in the isolated areas consists of water tanks (capacity 5 m³) and water bowsers (capacity 5 m³) and 10 Lpcd of water will be provided to each population. The numbers of water tanks and water bowsers are calculated as follows.

$$\text{population} \times 10 \text{ Lpcd} = \text{water demand}$$

$$\text{water demand} / 5 \text{ m}^3 = \text{number of water tank}$$

$$\text{number of water tank} / 6 \text{ locations/day} = \text{number of water bower}$$

Example of Madewachchiya Station for 45 - Parahalmillewa.

(45 - Parahalmillewa)

$$1,582 \times 10 \text{ Lpcd} = 15,820 \text{ Lpd} = 15.8 \text{ m}^3/\text{d} \Rightarrow 16 \text{ m}^3/\text{d}$$

$$16 \text{ m}^3 / 5 \text{ m}^3 = 3.3 \text{ tanks} \Rightarrow 4 \text{ tanks}$$

(Madewachchiya Station)

This station serves water to 15 water tanks.

$$15 \text{ tanks} / 6 \text{ locations/day} = 2.5 \text{ water bower} \Rightarrow 3 \text{ water bowsers}$$

The calculation results are shown in **Table 5.59**. Totally, 107 water tanks and 20 water bowsers are required for the water supply for the isolated areas.

CHAPTER 6 MANAGEMENT, OPERATION AND MAINTENANCE OF THE PROPOSED WATER SUPPLY SYSTEM

This chapter provides a brief background of NWSDB as an institution and examines its current organization structure, focusing on the organization and operating structure of the NWSDB RSC(N/C), which stands to benefit from the implementation of this Project. It assesses the capacity of the RSC(N/C) and proposes capacity building programmes to enhance organisational skills and improve individual and staff competencies to manage, operate and maintain the new facilities / system. It also assesses the organizations concerned in project implementation; then defines, describes and delineates the sharing of the roles and responsibilities among these organizations to mitigate managerial, financial and technical problems may arise in the case of the Project's implementation.

After an examination of the current O&M organisation, a strengthened O&M organisation is proposed to ensure the sound operation and maintenance of the facilities after its completion, and develop rapid response capability not only to resolve technical issues, but also to achieve the highest level of customer service and satisfaction.

Finally, the section examines the modes by which water supply services can be distributed to the RSC(N/C) service area, which also consists of CBOs. It proposes strategies and approaches that include the categorization of CBOs based on their willingness to connect, conditions for connecting, and the technical suitability of the CBO water supply system for bulk connection. It also examines the tariff system of the CBOs, which have varied tariff structures and charges. The examination of these tariff systems will keep the RSC(N/C) apprised of the average monthly household water bill on a per CBO basis as it embarks on its awareness campaign to get the CBOs to connect to its new distribution facilities.

6.1 Project Implementation Organisation

6.1.1 The National Water Supply and Drainage Board

The project implementation organisation is the NWSDB, which is the centralised water supply and sewerage organisation / utility in Sri Lanka providing 40% of the island population with access to safe piped borne water supply. Functionally, the NWSDB has the following major offices: (i) Policy and Planning, (ii) Water Supply Projects, (iii) Sewerage, (iv) Corporate Services, (v) Personnel and Administration (vi) Commercial (vii) Finance, and (viii) Internal Audit. Geographically, NWSDB has 11 regional support centres which are fully operational. These functional and geographic organisational dimensions are carried over to the organization structure of the regional support centres where the smallest operational unit is the water supply

scheme (WSS). There are currently 312 WSS operating in the NWSDB RSCs. The NWSDB Approved Cadre (2011) provides for 10,119 personnel covering 246 Categories and spread over 15 Board Grades. Actual number of personnel stood at 9,193, as of July 2012.

6.1.2 The NWSDB RSC(N/C)

The current total approved cadre of NWSDB RSC(N/C) is composed of the *NWSDB RSC(N/C) Approved Cadre* (2011) of 441 personnel, plus the O&M cadre of 44 personnel, approved by the Department of Management Services in July 2012, bringing to **485 the total number of personnel in the Approved Cadre**. There are five sections in the RSC(N/C), as shown in the table below, together with its current number of personnel:

Table 6.1 Current Number of NWSDB RSC(N/C) Personnel according to Section

| | Office /Section | Number of Staff |
|---|--------------------------------------|-----------------|
| 1 | Office of the Deputy General Manager | 04 |
| 2 | Development Section | 66 |
| 3 | Finance and Commercial Section | 03 |
| 4 | Human Resources Section | 10 |
| 5 | Information Technology Section | 02 |
| 6 | Operations Section | 307 |
| | Total | 392 |

Source: HR Section, as of 15 September 2012.

With the completion of the Project, the staff numbers are set to increase by **63 personnel** who will be assigned to manage, operate and maintain new facilities / water supply schemes. The recruitment of the new staff must adhere to the official approval process, and is recommended to commence at least a year before the projected date of the Project's completion. Also, two new units are proposed – the Area O&M (Satellite) Office and the Training Unit / Centre, in addition to three new water supply schemes (Rambewa, Mahakanadarawa and Wahalkada) and the expansion of three existing water supply schemes in the Project area (Kahatagasdigiliya, Kebithigollewa, and Medawachchiya).

6.1.3 Project Implementation Arrangements

The project implementation system will consist of the following: (i) The *project executing agency* will be the MWSD. Its role will be oversight monitoring of NWSDB's responsibilities in implementing the project. This will be performed through its Planning and Monitoring Division and its Procurement Division. (ii) The *project implementing agency* will be NWSDB. Its role will be technical monitoring and financial monitoring of the project, which it has had plenty of previous experiences. This will be performed by the Office of Water Supply Projects. (iii) A

project management unit (PMU), to be headed by a Project Director, will be created under the Office of Water Supply Projects, but will be physically based in the RSC(N/C). It will manage the day-to-day activities of the Project and will be involved in the entire cycle of the project as reflected in the whole range of services to be provided by the project consultants' team. (iv) The **project coordination committee** (PCC) will be composed of the representatives of the key stakeholders of the Project. The DGM of the RSC(N/C) will chair the PCC, with the PD of the PMCU as co-chair. The key stakeholders identified are the Central Environment Authority, the Irrigation Department, the Department of Wildlife Conservation, the Department of Health Services, the Department of Archaeology, the Department of Forestry, the Land Commissioner's General Department, the Local Authorities and representatives of Community-Based Organisations in the six project areas.

Table 6.2 Roles and Responsibilities of Project Organisations

| PROJECT ORGANISATION | INSTITUTION | MAIN ROLE | RESPONSIBILITY |
|--|--|--|---------------------------------------|
| Project Executing Agency | Ministry of Water Supply and Drainage | Oversight | General |
| | | | Procurement |
| | | | Disbursement |
| Project Implementation Agency | National Water Supply and Drainage Board | Technical Supervision and Monitoring | Procurement |
| | | | Disbursement |
| | | | Monitoring |
| Project Management and Coordination Unit | National Water Supply and Drainage Board | Project Management, Field Supervision, Monitoring and Coordination | General |
| | NWSDB RSC(N/C) | Coordination | Project Management |
| Project Coordination Committee | Key Stakeholders | Coordination | Coordination of Implementation Issues |

6.1.4 Capacity Development of the Implementation Organisation

Training and development – planning, developing and implementing the *Staff Training Plan* – is centralised in the NWSDB Head Office through its Manpower Development and Training Office. This unit conducts technical, non-technical, and computer courses not only for the internal participants, but also for external institutions. It also sends employees to in-country external training programmes categorised into graduate, postgraduate degree courses, and diploma and other short courses, as well as sends key personnel to receive training overseas. For 2012, the NWSDB is conducting around 154 training courses, equivalent to 15,000 training hours.

It is recommended that training be regionalised not only for RSC participants to save on travel time and accommodation, or to maximise training benefits to cover other staff; but more so in having the programmes effectively address the actual training needs of RSC's staff. Towards

this end, the organisational capacity of RSC(N/C) should be enhanced to a level that it can plan, develop and implement its own training programs for its own staff, the staff of neighbouring RSCs and also that of external institutions. This entails the development of a North Central Training Plan, organising a regional-level training unit / centre, and staffing it by seven personnel to implement the training plan by 2018.

As to enhancing staff capacity, the following capacity development activities and outputs are recommended:

Table 6.3 Proposed Capacity Development Activities and Outputs

| | Activities | Outputs |
|----|---|---|
| 1. | Conceptualize, develop and conduct the in-country technical and non-technical training courses | <ul style="list-style-type: none"> • Conduct of four technical training courses: <ul style="list-style-type: none"> ○ Project Management ○ Water Treatment Plant O&M ○ Water Distribution System O&M ○ Water Quality Monitoring • Conduct of three non technical training courses: <ul style="list-style-type: none"> ○ Human Resources Management (focus on Training and Development) ○ Public Information, Education and Communication ○ Trainers Training |
| 2. | Develop the five-year Training and Development Plan for the RSC(N/C), which will require the completion of a Training Needs Assessment as baseline information | <ul style="list-style-type: none"> • Training Needs Assessment Report • Five-Year Training and Development Plan |
| 3. | Develop course modules and training materials for the seven training courses | <ul style="list-style-type: none"> • Course modules and training materials for the four technical training courses • Course modules and training materials for the three non-technical training courses |
| 4. | Develop the WTP Operation and Maintenance Manual, the O&M Water Distribution System Operation and Maintenance Manual, and the Water Quality Monitoring Manual subsequent to the conduct of the three training courses under the same topic/area | <ul style="list-style-type: none"> • WTP Operation and Maintenance Manual • O&M Water Distribution System Operation and Maintenance Manual • Water Quality Monitoring Procedural Manual |
| 5. | Design and conduct an overseas training programme for NWSDB Head Office and RSC(N/C) top management | <ul style="list-style-type: none"> • Conduct of Overseas Training on Water Utility Best Practices |

6.2 Operation and Maintenance Organisation

Figure 6.1 shows the operation and maintenance organisation after the project completion and the supporting system by the existing organizations.

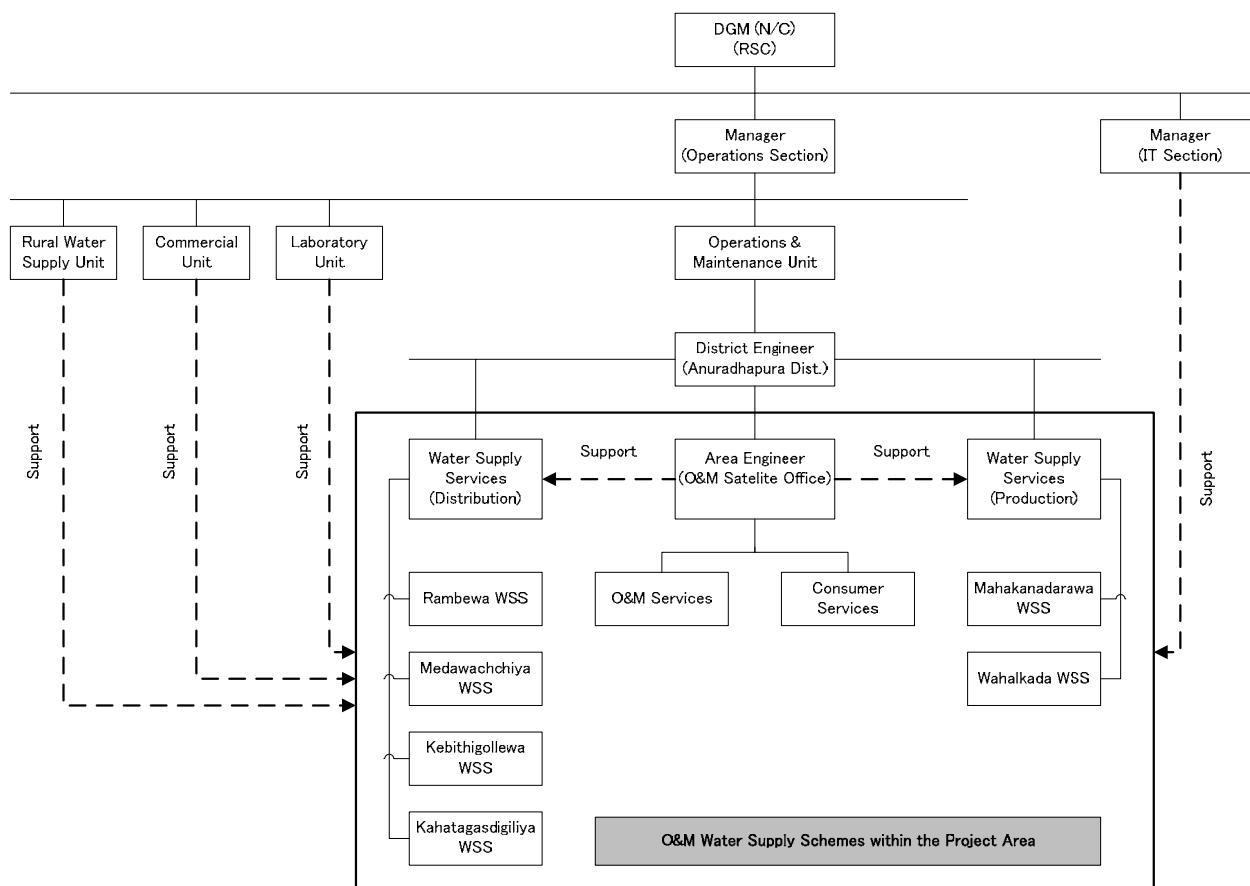

Figure 6.1 Operation and Maintenance Organisation after the Project Completion

The staff requirement for operation and maintenance after the project completion is shown in Table 6.4.

表 6.4 Staff Requirement for Operation and Maintenance after the Project Completion

| | Saterite Office (Medawachchiya) | WTP | | Service Centre (Transmission / Distribution) | | | |
|----------------------------------|------------------------------------|----------------|-----------|--|---------------|------------------------------|-------------------------------------|
| | | Mahakanadarawa | Wahalkada | Rambewa | Medawachchiya | Kebithigollewa (Padaviya) | Kahatagasdigiliya (Horowpothana) |
| Area Engineer | 1 | | | | | | |
| Electrical Engineer | 1 | | | | | | |
| Mechanical Engineer | 1 | | | | | | |
| Engineer Assistant (WTP) | | 1 | 1 | | | | |
| Engineer Assistant (O&M) | | | | 1 | 1 (1) | 1 (1) | 1 (1) |
| Engineer Assistant (Mnechanical) | 1 | | | | | | |
| Engineer Assistant (Electrical) | 1 | | | | | | |
| Consumer Relation Assistant | 1 | | | | | | |
| Plant Technitian | | 3 | 3 | | | | |
| Pump Operator Mechanic | | 1 | 1 | 1 | 4 (3) | 7 (6) | 3 (1) |
| Electrician | 2 | 1 | 1 | | | | |
| Mechanics | 2 | | | | | | |
| Lab Attendant | | 1 | 1 | | | | |
| Meter Reader | | | | | 1 (1) | | |
| Pipefitter | | 1 | | 2 | 2 (1) | 3 (1) | 3 (1) |
| Driver | 1 | | | | 1 | 1 | 1 |
| Caretaker | | 1 | 1 | 1 | 2 | 3 | 4 |
| Labourer | 2 | 1 | 2 | 1 | 3 (1) | 9 (4) | 6 (4) |
| Total | 13 | 10 | 10 | 6 | 14 (6) | 24 (16) | 18 (9) |

Bold number shows the Officer-in-Charge (OIC).
The figures in parenthesis show the number of present staff.

6.2.1 Additional O&M Staff/Cadre for the Existing WSS in the Project Area

There are three water supply schemes presently operating in the Project Area. However, Rambewa will need to be organised into a new water supply scheme to manage the newly constructed facilities that will be operational by 2018. Meantime, the other three existing WSS shall be expanded to enable it to take on the added O&M responsibilities given the new facilities.

6.2.2 New O&M Cadre for Mahakanadarawa and Wahalkada Water Supply Schemes

Two new water supply schemes are to be organised to operate and maintain the Mahakanadarawa and Wahalkada water treatment plants before the end of the construction period, to have ample lead time to train for the pre-operation and start-up operational phases of the WTPs.

6.2.3 Proposed O&M Area (Satellite) Office for WSS in the Project Area

It is proposed that the O&M satellite office be organised in Medawachchiya, to be staffed by five personnel (headed by an officer-in-charge). The area office will function to: (i) *deliver quick response to O&M and technical issues* that need immediate resolution and which were inadequately dealt with by the schemes; (ii) *provide closer consumer service support services* considering the increased number of new customers to be generated by the completion of the Project, (iii) *spearhead the public information, education and communication (IEC) programme* on the importance of water to health; (iv) *assist the WSS in delivering potable water* to the remote villages not covered by the piped system, but which is required due to water quality health concerns.

6.2.4 Enhancing Other Sections / Units in Support of O&M

There are other sections and units in the RSC(N/C) that need to be enhanced to support the proper operation and maintenance of the new facilities. These are the (i) regional laboratory, for the upgrade of laboratory facilities and training on water quality monitoring; (ii) the rural water supply unit, for capacity building of CBOs and spearheading the public awareness campaign under the IEC programme; (iii) the commercial unit, for improving customer services guided by the NWSDB Customer Charter; and (iv) the IT section, for the enhancement of customer services through the expanded use of the call centre service, and the improvement of billing efficiency with the use of a point-of-sales system.

6.2.5 Supporting O&M through Equipment and Engineering Software

It is equally important that the water supply schemes, the O&M area office, and the regional workshop are equipped with basic O&M equipment and vehicles. The equipment proposed are four units each of asphalt cutters, tapping machines, compactors, and vibrating hammers; six units of portable generators; one unit of small lift hoist / crane; one unit of pump bed test / machine; and 20 units of assorted vehicles (cabs, water bowser, mini-backhoe and motorcycles). The latest versions of engineering software (01 with 5-user licence) required are: Small World Water Network Information System, ArcGIS, WaterCAD, Surge Analysis Software, Structural Design Software, and Project Management Software

6.3 Mode of Water Supply Services

6.3.1 Community Based Organisations

CBOs operating in the Project area were formed as rural community organisations capable of providing and sustaining the management of the water supply and sanitation facilities to their beneficiary community under either ADB, World Bank or bilateral projects. The functions of the CBOs are enshrined in the National Policy for Rural Water Supply.

6.3.2 CBO-Managed Water Supply Schemes in the Project Area

Based on the criteria for the inclusion of CBOs into the project's service area, three CBOs, namely (i) Tristar and (ii) Dirimathaya and (iii) Al Naja will be excluded due to a low level of fluoride for (i) and (ii) and the location far away from the proposed transmission pipeline route for (iii), as described in **Section 4.2.5**.

In terms of suitability of the CBOs for inclusion / connection to the bulk water system, 36 CBOs or 72 percent are technically suitable, thus can be recommended for immediate inclusion; 06 CBOs or 12 percent are recommended, but improvements are required; 05 CBOs or 10 percent are also recommended, pending resolution of larger issues; and 03 or six percent are excluded, as explained above. Actions to address the issues by the RSC(N/C) are proposed in this Study.

As for the willingness of the CBOs to connect to the bulk water system, a resounding majority of 42 CBOs or 84 percent are willing to connect to the new distribution system. One CBO (two percent) said it was not willing to connect; one (two percent) was undecided; one (two percent) did not respond. On the other hand, one (two percent) does not have CBO/scheme, while one (two percent) is a rainwater harvesting scheme in which 60 households have individual collection systems but CBO is willing to connect to a new pipe borne water supply system. Three CBOs (six percent) have been excluded from the study.

6.3.3 Approaches in Providing Water Supply Services to the CBOs

In view of the preceding, it is proposed to categorise CBOs for inter-connection with the bulk supply, as shown below:

Table 6.5 Categorisation of CBOs Based on Willingness to Connect, Conditions Set and Technical Suitability

| | CATEGORY 1 | CATEGORY 2 | CATEGORY 3 | CATEGORY 4 | CATEGORY 5 |
|--------------|---|--|---|--|--|
| CBO | <ul style="list-style-type: none"> • Willing to connect • No conditions • Suitable for bulk supply | <ul style="list-style-type: none"> • Willing to connect • No conditions • Requires improvements | <ul style="list-style-type: none"> • Willing to connect • With conditions • Suitable for bulk supply | <ul style="list-style-type: none"> • Willing to connect • Requires major rehabilitation • Undecided | <ul style="list-style-type: none"> • Not willing to connect • Excluded |
| TOTAL | 11 | 6 | 24 | 5 | 4 |
| % | 22 | 12 | 48 | 10 | 8 |

It must be emphasized that CBOs are composed of beneficiary households, formed on the basis of consultation and participation, which has become an important factor in its success. Through this process, the various stakeholders' influence, share control and make decisions over development initiatives and resources that affect them. Thus, RSC(N/C) must be able to provide water supply through the following strategies: (i) bulk distribution through the existing CBOs by encouraging them to connect to the new system; (ii) direct distribution, by constructing the required distribution lines to an expanded urban centre or new cluster of populations, or by takeover or turnover of CBO facilities, depending on the arrangement with the CBOs; and (iii) distribution by water tankers to isolated or far flung areas that are not reachable by the distribution system.

Table 6.6 Manner of Providing Water Supply Services

| DISTRIBUTION METHOD | By Existing CBO | By Direct Distribution | | | By Water Tankers |
|--------------------------------|---|---|---|--|--|
| OVERVIEW | Bulk supply to CBO by RSC(N/C) | Turnover of CBO facilities to RSC(N/C) | Takeover of CBO facilities by RSC(N/C) | By NWSDB RSC(N/C) | By NWSDB RSC(N/C) |
| DESCRIPTION | CBO keeps its current organisational characteristics | CBO voluntarily turns over facilities for management by RSC | RSC employs compulsory take over of CBO facilities | RSC expands its existing urban service area(s) | Isolated household clusters not part of CBO or RSC |
| DISTRIBUTION FACILITIES | <ul style="list-style-type: none"> • CBO to connect to RSC using bulk meter • CBO to provide rehabilitation to minor/damaged facilities • CBO to expand own distribution network | <ul style="list-style-type: none"> • RSC to provide rehabilitation to minor/damaged facilities • RSC to expand distribution network | <ul style="list-style-type: none"> • RSC to provide rehabilitation to minor/damaged facilities • RSC to expand distribution network | RSC to construct new distribution network(s) | Constructing distribution pipelines is not economically feasible |
| MANAGEMENT AUTHORITY | <ul style="list-style-type: none"> • CBO retains management authority | <ul style="list-style-type: none"> • Management authority is RSC | <ul style="list-style-type: none"> • Management authority is RSC | <ul style="list-style-type: none"> • Management authority is RSC | <ul style="list-style-type: none"> • Management authority is RSC |
| O&M RESPONSIBILITY | <ul style="list-style-type: none"> • CBO retains responsibility for O&M | <ul style="list-style-type: none"> • Responsibility for O&M to be decided between CBO and RSC(N/C) | <ul style="list-style-type: none"> • Responsibility for O&M to be decided between CBO and RSC(N/C) | <ul style="list-style-type: none"> • RSC retains responsibility for O&M | <ul style="list-style-type: none"> • RSC retains responsibility for O&M |
| TARIFF COLLECTION | <ul style="list-style-type: none"> • CBO retains responsibility for tariff collection | <ul style="list-style-type: none"> • Responsibility for tariff collection to be decided between CBO and RSC(N/C) | <ul style="list-style-type: none"> • Responsibility for tariff collection to be decided between CBO and RSC(N/C) | <ul style="list-style-type: none"> • RSC retains responsibility for tariff collection | <ul style="list-style-type: none"> • RSC is responsible for setting water charges |

6.4 Water Tariff Systems

The CBO tariff system is prepared with the assistance of the CBO itself and the CBO project proponents. Usually, the system includes (i) replacement cost (ii) future rehabilitation cost (iii) capital investment (iv) O&M cost, including staff salary. All tariff systems are presented and accepted by the CBO in a general meeting, with a required minimum participation / presence of two-thirds of its membership.

Domestic water tariff is available for 44 out of 50 CBO schemes in the Project area, while non-domestic water tariff is available for only 25 CBO schemes. In addition, tariff charges vary from scheme to scheme. There is a basic monthly fee levied on each customer, with majority of CBOs (52 percent) charging within the range of RS. 50-59.

As for the per unit consumption charges, the results of the Status Survey revealed that ADB-supported projects generally charge lower tariffs, which range from RS. 15 to 20 per unit; while CWSSP schemes have higher tariff, varying from 21 to 27 per unit.

Tariff structure also varies among CBOs. Although all CBOs have a basic charge per household connection, tariff is structured using a unit rate with a block progressive rate. Volumetric rate increases as the consumption increases. The Status Survey used a sample rate analysis for a sample household in each of the 50 CBOs with an average monthly consumption of 18 cubic meters. The formula used is: Base Charge + Consumption Tariff + Tax. The results of the sample rate analysis provide a good idea, for comparison purposes, on the average water bill of a sample household in each CBO.

Sample households of 18 CBOs, or 36 percent, have water bills within the range of RS. 300-399; the sample households of 13 CBOs, or 26 percent, have water bills within the range of RS. 400-499.

Table 6.7 Sample Analysis of Monthly Water Bill of CBO Households

| Sample Monthly Water Bill (in RS.) | 200-299 | 300-399 | 400-499 | 500-599 | 600-699 | No data |
|------------------------------------|---------|---------|---------|---------|---------|---------|
| No. of CBOs | 9 | 18 | 13 | 3 | 1 | 6 |
| % | 18 | 36 | 26 | 6 | 2 | 12 |

This amount is similar to the one confirmed through the social survey conducted which found out that the average amount paid by CBO users come up to RS. 346 per month, while the average amount paid by the NWSDB RSC(N/C) is RS. 400 per month.

After the new water supply system will enter into operation, NWSDB will be responsible for management, operation and maintenance of new systems. If NWSDB will take over the existing CBO system based on the resolution at the general meeting of the community, the NWSDB's water tariff is imposed to the respective customers, while if the existing CBO will keep an independence from NWSDB, the NWSDB's bulk water supply rate will be imposed to the total water consumption of the CBO. For the new service area, since NWSDB has no intention to allow the new CBO establishment. NWSDB's water tariff will be applied to all the new customers. Takeover of the existing CBO facilities will be done in principle for nothing, since the materials required for the construction of facilities were originally provided by the Government for nothing.

In case of a bulk supply from NWSDB to existing CBOs, the bulk supply charge will be newly imposed, while the consumerable expenditures such as electricity or diesel oil and chlorine will be cut from the present expenditures. The profit/loss is then estimated as indicated in **Table 6.8**, in which 17 CBOs (about 41%) out of 41CBOs will show a loss. Although the total payment of one community will be higher than the current one, the water supply by NWSDB still has advantages of (i) safe water supply to meet the Sri Lankan drinking water standards even for fluoride, (ii) stable water supply even in the dry season, (iii) proper chlorination of water, (iv) professional operation and maintenance for distribution facilities such as replacement of defective water meters, repair of leaks.

6.5 Cost Sharing

The connection work of transmission mains and sub-mains to the existing elevated tanks under the CBOs water supply schemes will be done in the Project with no cost to existing CBOs.

In the new service area, distribution mains and sub-systems will be installed in the Project. For small-size distribution pipes (below 100 mm) NWSDB has a plan to provide materials and install them by the people's labour contribution based on the request of the community people under the NWSDB's supervision, which is also helpful to heighten the willingness to connect to a new system. In case of a new connection, NWSDB is responsible for the service pipe installation work from the branch of distribution pipes to a water meter, while an applicant for the remaining work from the meter outlet to the taps. The connection fee varies from Rs.4,000 to Rs.20,000 depending on the cost estimation. If there is a pavement road, the cost to break and reinstate the pavement is borne by an applicant who is required to pay such cost to the relevant authorities beforehand.

Table 6.8 Estimation of Revenue and Expenditure in Case of an Application of Bulk Supply Charge to Existing CBOs

| DSD | GND | CBO | No. of Connections (Conn.) | Water Consumption (m3/month) | Bulk Supply Payment (Rs./year) | Revenue (Rs./year) | Present Expenditure at CBOs | | | | Profit/Loss (Rs./year) |
|-----------------------------|-------------------------------|-------------------|----------------------------|------------------------------|--------------------------------|--------------------|-----------------------------|----------------------|------------------------|------------------------|------------------------|
| | | | | | | | Total (Rs./year) | Personnel (Rs./year) | Consumables (Rs./year) | Maintenance (Rs./year) | |
| Padaviya | Padaviya | Suwasehana | 192 | 1,989 | 405,756 | 1,025,364 | 425,928 | 84,000 | 101,928 | 240,000 | 295,608 |
| | Parakramapura | Parakum | 576 | 9,307 | 1,898,628 | 2,045,400 | 618,380 | 348,000 | 192,780 | 77,600 | -278,828 |
| | Boghawewa | Suwasehana | 186 | 2,661 | 542,844 | 730,052 | 478,348 | 180,000 | 164,484 | 133,864 | -126,656 |
| Kebithigollewa | Ayyatigewewa | Shakthi | 235 | 2,583 | 526,932 | 562,758 | 534,519 | 216,000 | 148,589 | 169,930 | -350,104 |
| Medawachchiya | Kidawarankulama | Sisila Diyadahara | 190 | 1,762 | 359,448 | 535,060 | 373,612 | 156,000 | 207,612 | 10,000 | 9,612 |
| | Maha Kumbugollewa | Diriyamatha | 180 | 1,460 | 297,840 | 562,228 | 421,037 | 180,000 | 141,037 | 100,000 | -15,612 |
| | Periyakulama & Yakawewa | Diriyashakthi | 138 | 1,365 | 278,460 | 490,000 | 362,432 | 132,000 | 207,432 | 23,000 | 56,540 |
| | Hirilugama | Ekamuthu | 173 | 1,953 | 398,412 | 394,796 | 358,672 | 198,000 | 120,672 | 40,000 | -241,616 |
| | Athakade | Ridinadi | 121 | 938 | 191,352 | 446,472 | 224,569 | 120,000 | 72,480 | 32,089 | 103,031 |
| | Ataweeraogollewa | Samagi | 110 | 1,266 | 258,264 | 434,792 | 289,904 | 96,000 | 183,904 | 10,000 | 70,528 |
| | Maha Divulwewa | Gemunu | 70 | 487 | 99,348 | 192,684 | 81,420 | 30,000 | 51,420 | 0 | 63,336 |
| | Kadawathgama | Isuru | 181 | 1,915 | 390,660 | 714,806 | 476,204 | 258,000 | 139,404 | 78,800 | -12,654 |
| | Viralmurippuwa | Ran Arulnalu | 192 | 1,907 | 389,028 | 402,264 | 176,323 | 102,000 | 70,188 | 4,135 | -92,899 |
| | Katuwela | Jayashakthi | 220 | 2,932 | 598,128 | 927,904 | 632,164 | 288,000 | 294,164 | 50,000 | -8,224 |
| | Helabagaswewa | Samagi | 190 | 1,818 | 370,872 | 1,270,584 | 332,448 | 190,800 | 106,848 | 34,800 | 674,112 |
| Kirigalwewa | Nelun | 139 | 660 | 134,640 | 286,620 | 159,624 | 72,000 | 87,624 | 0 | 79,980 | |
| Unagaswewa | Randiy a Dhahara | 107 | 1,018 | 207,672 | 527,540 | 291,700 | 78,000 | 181,200 | 32,500 | 209,368 | |
| Rambewa | Wewelketia & Thamarahamillewa | Rangiri | 120 | 797 | 162,588 | 341,832 | 192,492 | 96,000 | 96,492 | 0 | 83,244 |
| | Talgahawewa | Samagi | 135 | 973 | 198,492 | 432,168 | 260,950 | 162,000 | 71,440 | 27,510 | 44,166 |
| | Balahodawewa | Pragthi | 128 | 726 | 148,104 | 290,772 | 123,515 | 66,000 | 46,748 | 10,767 | 65,901 |
| | Ihala Kolongasw. | Dimuthu | 67 | 417 | 85,068 | 147,732 | 81,263 | 48,000 | 30,576 | 2,687 | 11,977 |
| | Mahakanadarawa 2 | Mahasen | 153 | 1,336 | 272,544 | 319,376 | 266,966 | 120,000 | 134,016 | 12,950 | -86,118 |
| | Mahakanadarawa 1 | Nildiyadahara | 144 | 1,175 | 239,700 | 391,396 | 242,219 | 114,000 | 93,219 | 35,000 | 2,696 |
| | Kedewa & Galkandegama | Swashakthi | 154 | 949 | 193,596 | 441,276 | 199,605 | 120,000 | 64,968 | 14,637 | 113,043 |
| | Ikirigollewa | Ikra | 613 | 8,645 | 1,763,580 | 1,883,160 | 1,084,874 | 540,000 | 528,361 | 16,513 | -436,933 |
| | Katukeliyawa | Eksath | 118 | 1,632 | 332,928 | 305,352 | 226,842 | 96,000 | 54,684 | 76,158 | -199,734 |
| | Wahamalgotollewa 3 | Ekamuthu | 245 | 1,448 | 295,392 | 616,920 | 347,832 | 168,000 | 175,332 | 4,500 | 149,028 |
| | Sanglikanadarawa | Arunalu | 183 | 2,834 | 578,136 | 974,584 | 466,315 | 180,000 | 217,920 | 68,395 | 148,053 |
| Horowpothana | Wadigawewa | Pradeepa | 161 | 1,578 | 321,912 | 382,908 | 226,651 | 120,000 | 52,880 | 53,771 | -112,775 |
| | Maradankadawela | Hansajala | 111 | 1,231 | 251,124 | 392,044 | 224,817 | | 82,632 | 142,185 | -1,265 |
| | Kapugollewa | Jalasavi | 157 | 1,107 | 225,828 | 331,324 | 224,859 | 94,000 | 82,882 | 47,977 | -36,481 |
| | Parangiyawadiya | Upul | 195 | 1,691 | 344,964 | 613,428 | 224,501 | 132,000 | 69,701 | 22,800 | 113,664 |
| Kahatagasdigiliya | Moragahawela | Pragathi | 131 | 855 | 174,420 | 339,660 | 176,620 | 120,000 | 46,620 | 10,000 | 35,240 |
| | Kubukgollewa | Ekamuthu | 78 | 447 | 91,188 | 200,900 | 159,532 | 48,000 | 102,172 | 9,360 | 52,352 |
| | Pandarellawa & Panwella | Sobasisila | 178 | 2,254 | 459,816 | 510,720 | 242,664 | 120,000 | 122,664 | 0 | -69,096 |
| | Mee-Kumbukwewa | Apsara | 101 | 492 | 100,368 | 290,592 | 192,548 | 96,000 | 94,548 | 2,000 | 92,224 |
| | Mahawewa | Praja Shakthi | 165 | 1,089 | 222,156 | 624,740 | 368,669 | 150,000 | 99,395 | 119,274 | 133,310 |
| | Maha Kubukwewa | Vajira | 135 | 1,233 | 251,532 | 431,496 | 290,632 | 198,000 | 70,632 | 22,000 | -40,036 |
| | Gonumeru Wewa | Senath | 79 | 525 | 107,100 | 275,312 | 185,640 | 24,000 | 134,640 | 27,000 | 117,212 |
| | Palippothana - Kirigallewa | Janasetha | 189 | 1,952 | 398,208 | 615,476 | 249,024 | 120,000 | 117,024 | 12,000 | 85,268 |
| M. Kiribbewa & Kurukuragama | Eksath | 100 | 930 | 189,720 | 214,800 | 196,116 | 96,000 | 100,116 | 0 | -70,920 | |

Note: Profit/Loss = Revenue - (Bulk Supply Payment + Personnel Expenditure + Maintenance Expenditure)

The water tariff for the bulk supply of water to CBOs is Rs.17 per cubic meter with no service charge.

CHAPTER 7 PROJECT COST

The project cost for the Anuradhapura North Integrated Water Project is prepared based on the list of the proposed water facilities provided in Chapter 5.

7.1 Preamble (Basis for Cost Estimation)

Following conditions were referenced from the JICA F/F Common Matters to be considered for Sri Lanka in preparation of the cost estimation for this project.

| | |
|--------------------------|--|
| 1) Base Year | August 2012 |
| 2) Exchange Rate | USD 1 = JPY 78.2 USD 1 = Rs. 132.1 Rs. 1 = JPY 0.592 |
| 3) Price Escalation Rate | Foreign Currency = 2.1%, Local Currency = 4.0% |
| 4) Physical Contingency | 5.0% |
| 5) Administration Cost | 9.0% of eligible and non-eligible portions |
| 6) VAT | 12 % (of the expenditure in local currency and foreign currency of the eligible portion) |
| 7) Import Tax | 27% (of the expenditure in foreign currency of eligible construction portion) |

Import Taxes in Sri Lanka are set forth and overseen by Sri Lanka Custom and vary depended on materials. Per Annex 2 in the NWSDB Rate 2012 and Sri Lanka Custom Tariff book, a total duty as % of CIF is obtained as follow:

- Civil Components:
 - HDPE (Tariff Heading 3917.21): 46%
 - Valves and Parts (Tariff Heading 8481.10-90): 12%
- Mechanical Components (BOQ base) 23.3%
- Electrical Components (BOQ base): 15.0%
 - Including following items, but not limited,
 - Pump (Tariff Heading 8413.70.10): 35%
 - Pump Parts (Tariff Heading 8413.91): 0%

7.2 References for Unit Prices

For water supply and drainage projects in Sri Lanka, NWSDB publishes annually unit prices as in

a book called “Rates”. There are two ways to prepare cost estimation using the Rates for these types of projects in Sri Lanka: 1) Rates for Total Cost Estimates, and 2) Rates for BOQ. The “Rates for Total Cost Estimates” uses one all-inclusive unit price, which includes all elements of a particular item to be installed or constructed. On the other hand, the “Rates for BOQ” add all associated unit prices to derive a cost to install or build the item.

To prepare the cost estimation for this project, the information on the unit prices of materials, equipment, and labour in Sri Lanka was collected from both NWSDB Rates 2012 and the local and international contractors, which are qualified for participating ICB projects, and then compared the collected prices to analyse the unit price differences. The unit prices collected from the contractors reflect the most current marketing prices for construction materials and activities. The NWSDB Rate Book projects unit prices and BOQs based on the collected construction cost data up to the previous years. Therefore, these prices may not reflect the most accurate prices for the current market in Sri Lanka. The JICA Team carefully compared these unit prices based on the current price escalation for construction costs in Sri Lanka and the trends and determined unit prices to be utilized for this project.

7.3 Considerations for Preparing Cost Estimation

Based on the interviews and obtained data from the local contractors and agencies in preparation of the project cost estimation, the following items were considered.

(1) Rock Excavation

Based on the field visits to the proposed water facility sites, different sizes of large rocks above ground and/or at ground in some locations were observed. In addition, based on the geotechnical report prepared by the local consultant, the following information were observed and summarized below:

- **Basement Rock:**
 - The geotechnical reports indicate that rocks are observed approximately 1 m below at a majority of investigated places for the proposed transmission and distribution main pipes.
 - The geotechnical reports indicate that rocks are observed approximately 1.5 m below at a majority of investigated places for the proposed structures.

The soil covers over the proposed transmission and distribution main pipes and the distribution sub pipes from the top of the pipes are 1.2 m and 1.0 m respectively. The largest diameter of the proposed pipes is HDPE 450 mm. Therefore, the trench depth for the pipes is approximately 2 m from the ground level with all other foundation materials and pipe wall thickness. For purposes of the cost estimation, 50% ($1.0/2.0 = 0.5$) of the overall excavation

related to the pipe installation is considered as rock excavation.

For the concrete structure such as the proposed ground reservoirs and elevated tanks, the excavation depth varies from a range of 3 m to 7 m below the ground level where completely weathered rock and basement rock are observed per the obtained borehole investigation information to estimate the rock excavation. The estimated average depth of the proposed structures is 2.5 m from the ground. As stated above, the average depth of the rock beneath the ground starts approximately at 1.5 m. Therefore, approximately 40% ($1.0/2.5=0.4$) of the excavation for the proposed structures is included as rock excavation.

To research the ratio among the different soil types of excavation, the unit prices were collected from the local contractors and Rates 2012. **Table 7.1** shows the comparison summary of the unit prices for the different soil types of excavation by different resources. Based on the hearings and the collected data from the local contractors, a unit price of rock excavation is approximately 5 to 9 times more than that of normal soil excavation. A unit price of rock excavation used in the project cost estimation is set forth by 5 times more than that of normal soil.

Table 7.1 Excavation Unit Price with Different Soil Types

| Excavation Items | Specification | Unit | NWSDB ¹ | | Sierra ² | | Maeda ³ | |
|--------------------|-----------------|----------------|--------------------|-------|---------------------|-------|--------------------|-------|
| | | | Rs | Ratio | Rs | Ratio | Rs | Ratio |
| Normal Soil | 0 < Depth < 1 m | m ³ | 548 | 1.00 | 1,500 | 1.00 | 572 | 1.00 |
| Disintegrated Rock | 0 < Depth < 1 m | m ³ | 1,567 | 2.86 | 1,800 | 1.20 | 635 | 1.11 |
| Rock | 0 < Depth < 1 m | m ³ | 2,615 | 4.77 | 9,000 | 6.00 | 4,826 | 8.44 |

Source: 1. NWSDB 2012 Rates p.61, 2. Unit Prices obtained from Sierra Construction, 3. Unit Prices obtained from Maeda Corporation

Note: Unit prices are used to compare the ratio between normal soil and rock excavation.

(2) Procurement Procedure

In Sri Lanka, bidding document procurement of works procedure is set forth by the Procurement Manual published by Sri Lanka National Procurement Agency, commonly known as “Blue Book” in Sri Lanka. According to the manual, a different authority oversees projects depending on a total cost of the project as shown in the table below:

Table 7.2 Committee Involvements According to Project Costs

| Authority | Foreign Founded Projects |
|---|--------------------------|
| Cabinet Appointed Procurement Committee (CAPC) | More than Rs 500 Million |
| Ministry Procurement Committee (MPC) | Up to Rs. 500 Million |
| Department Procurement Committee (DPC)/ Project Procurement Committee (PPC) - NWSDB | Up to Rs 150 Million |
| Regional Procurement Committee | Up to Rs 5 Million |

Resource: Sri Lanka Procurement Manual by National Procurement Agency`

According to the Blue Book, FIDIC 2010 MDB Harmonized Version shall be referenced for International Competitive Bidding (ICB), and the Standard Bidding Document Procurement of Works by Institute for Construction Training and Development (ICTAD) shall be referenced for National Competitive Bidding (NCB). Even though the procurement guidelines and rules are different for different type of biddings, the basic flow of the bidding procedure is similar to each other.

However, the schedule may be affected by the involvement of different authorities due to longer duration on overall evaluation process, which can be expected to be 30 days longer or more if more than one committee is involved. The overall schedule and duration of the procurement procedure is determined during preparation of tender documents.

7.4 Project Cost Estimation

A summary of estimate capital cost for the Anuradhapura North Integrated Water Supply Project is tabulated in **Table 7.3**,

Table 7.5 and **Table 7.6** include the annual fund requirement (JICA Loan). The estimate capital cost for the Mahakanadarawa portion of the project subjected to the JICA Loan is 5.166 billion yen (Foreign Portion: 2.623 billion yen and Local Portion: RS. 4.295 billion) and that for the Wahalkada portion is 7.696 billion Yen (Foreign Portion: 4.045 billion Yen and Local Portion: Rs. 6.166 billion). However, for Wahalkada Scheme the Project cost will be discussed and finalised in the Appraisal. The project cost estimation is prepared for the facilities proposed for the projected water demand of 2034 and for some facilities to be constructed for the water demand of 2024 under stage construction which was discussed more detail in **Chapter 5**.

The details of the construction cost are included in **Appendix 7.4**.

Table 7.3 Mahakanadarawa Estimated Project Costs (Stage-1)

| Item | Cost in Million | | |
|---|-----------------|--------------|--------------|
| | FC | LC | Total |
| | (JPY) | (Rs.) | (JPY) |
| A. ELIGIBLE PORTION | | | |
| I) Procurement / Construction | 1,951 | 3,990 | 4,314 |
| II) Consulting Services | 378 | 305 | 559 |
| Sub-total (I + II) | 2,330 | 4,295 | 4,872 |
| B. NON ELIGIBLE PORTION | | | |
| a. Procurement/ Construction | 12 | 97 | 69 |
| b. Land Acquisition | 0 | 19 | 11 |
| c. Administration cost | 0 | 753 | 446 |
| d. VAT | 0 | 1,004 | 594 |
| e. Import Tax | 0 | 895 | 530 |
| Sub-total (a+b+c+d+e) | 12 | 2,769 | 1,651 |
| TOTAL (A+B) | 2,341 | 7,064 | 6,523 |
| C. INTEREST DURING CONSTRUCTION | 253 | 0 | 253 |
| D. COMMITMENT CHARGE | 41 | 0 | 41 |
| GRAND TOTAL (A+B+C+D) | 2,635 | 7,064 | 6,817 |
| E. JICA FINANCE PORTION INCLD. IDC (A + C + D) | 2,623 | 4,295 | 5,166 |

Table 7.4 Wahalkada Estimated Project Costs (Stage-1)

| Item | Cost in Million | | |
|---|-----------------|--------------|--------------|
| | FC | LC | Total |
| | (JPY) | (Rs.) | (JPY) |
| A. ELIGIBLE PORTION | | | |
| I) Procurement / Construction | 3,489 | 5,868 | 6,963 |
| II) Consulting Services | 175 | 298 | 352 |
| Sub-total (I + II) | 3,664 | 6,166 | 7,315 |
| B. NON ELIGIBLE PORTION | | | |
| a. Procurement/ Construction | 14 | 122 | 86 |
| b. Land Acquisition | 0 | 10 | 6 |
| c. Administration cost | 0 | 1,126 | 667 |
| d. VAT | 0 | 1,501 | 889 |
| e. Import Tax | 0 | 1,598 | 946 |
| Sub-total (a+b+c+d+e) | 14 | 4,358 | 2,594 |
| TOTAL (A+B) | 3,679 | 10,524 | 9,909 |
| C. INTEREST DURING CONSTRUCTION | 320 | 0 | 320 |
| D. COMMITMENT CHARGE | 61 | 0 | 61 |
| GRAND TOTAL (A+B+C+D) | 4,060 | 10,524 | 10,290 |
| E. JICA FINANCE PORTION INCLD. IDC (A + C + D) | 4,045 | 6,166 | 7,696 |

Note: The Project cost will be discussed and finalised in the Appraisal of Wahalkada Scheme.

Table 7.5 Mahakanadarawa Disbursement Schedule (Stage-1)

| Annual Fund Requirement | | | | | | | | | | | | | | | | | | | | | | | | | | | | | | | | | | | | | | | | | | | | |
|--|-------|-------|-----------|------|----|-------------------------|------|----|------------------|------|-----|-------|------|-----|-------|------|-------|-------|------|-------|-------|------|-----|-------|------|----|-------|--|--|--|--|--|--|--|--|--|--|--|--|--|--|--|--|--|
| Base Year for Cost Estimation: | | | Oct, 2012 | | | FC & Total: JPY million | | | LC : Rs. million | | | | | | | | | | | | | | | | | | | | | | | | | | | | | | | | | | | |
| Exchange Rates | | | Rs. = Yen | | | 0.592 | | | | | | | | | | | | | | | | | | | | | | | | | | | | | | | | | | | | | | |
| Price Escalation: | | | FC: 2.1% | | | LC: 4.0% | | | | | | | | | | | | | | | | | | | | | | | | | | | | | | | | | | | | | | |
| Physical Contingency | | | 5% | | | | | | | | | | | | | | | | | | | | | | | | | | | | | | | | | | | | | | | | | |
| Physical Contingency for Consultant | | | 5% | | | | | | | | | | | | | | | | | | | | | | | | | | | | | | | | | | | | | | | | | |
| Item | Total | | | 2012 | | | 2013 | | | 2014 | | | 2015 | | | 2016 | | | 2017 | | | 2018 | | | 2019 | | | | | | | | | | | | | | | | | | | |
| | FC | LC | Total | FC | LC | Total | FC | LC | Total | FC | LC | Total | FC | LC | Total | FC | LC | Total | FC | LC | Total | FC | LC | Total | FC | LC | Total | | | | | | | | | | | | | | | | | |
| A. ELIGIBLE PORTION | | | | | | | | | | | | | | | | | | | | | | | | | | | | | | | | | | | | | | | | | | | | |
| I) Procurement / Construction | 1,951 | 3,990 | 4,314 | 0 | 0 | 0 | 0 | 0 | 0 | 0 | 0 | 0 | 271 | 316 | 458 | 737 | 1,590 | 1,678 | 752 | 1,654 | 1,731 | 192 | 430 | 446 | 0 | 0 | 0 | | | | | | | | | | | | | | | | | |
| 1. Intake,WTP,Elevated Tanks and Grand Sumps | 708 | 1,697 | 1,712 | 0 | 0 | 0 | 0 | 0 | 0 | 0 | 0 | 0 | 71 | 170 | 171 | 283 | 679 | 685 | 283 | 679 | 685 | 71 | 170 | 171 | 0 | 0 | 0 | | | | | | | | | | | | | | | | | |
| 2. Transmission and Distribution Main | 944 | 540 | 1,263 | 0 | 0 | 0 | 0 | 0 | 0 | 0 | 0 | 0 | 172 | 98 | 230 | 343 | 196 | 459 | 343 | 196 | 459 | 86 | 49 | 115 | 0 | 0 | 0 | | | | | | | | | | | | | | | | | |
| 3. Distribution Sub System | 43 | 829 | 534 | 0 | 0 | 0 | 0 | 0 | 0 | 0 | 0 | 0 | 0 | 0 | 0 | 19 | 369 | 237 | 19 | 369 | 237 | 5 | 92 | 59 | 0 | 0 | 0 | | | | | | | | | | | | | | | | | |
| 4. O&M Equipment | 0 | 115 | 68 | 0 | 0 | 0 | 0 | 0 | 0 | 0 | 0 | 0 | 0 | 0 | 0 | 0 | 51 | 30 | 0 | 51 | 30 | 0 | 13 | 8 | 0 | 0 | 0 | | | | | | | | | | | | | | | | | |
| Base cost for JICA financing | 1,695 | 3,181 | 3,578 | 0 | 0 | 0 | 0 | 0 | 0 | 0 | 0 | 0 | 242 | 268 | 401 | 645 | 1,295 | 1,412 | 645 | 1,295 | 1,412 | 161 | 324 | 353 | 0 | 0 | 0 | | | | | | | | | | | | | | | | | |
| Price escalation | 164 | 620 | 531 | 0 | 0 | 0 | 0 | 0 | 0 | 0 | 0 | 0 | 16 | 33 | 35 | 56 | 220 | 186 | 71 | 280 | 237 | 21 | 86 | 72 | 0 | 0 | 0 | | | | | | | | | | | | | | | | | |
| Physical contingency | 93 | 190 | 205 | 0 | 0 | 0 | 0 | 0 | 0 | 0 | 0 | 0 | 13 | 15 | 22 | 35 | 76 | 80 | 36 | 79 | 82 | 9 | 20 | 21 | 0 | 0 | 0 | | | | | | | | | | | | | | | | | |
| II) Consulting services | 378 | 305 | 559 | 0 | 0 | 0 | 25 | 15 | 33 | 163 | 91 | 217 | 33 | 35 | 54 | 57 | 61 | 93 | 66 | 73 | 109 | 31 | 29 | 48 | 4 | 1 | 4 | | | | | | | | | | | | | | | | | |
| Base cost | 337 | 253 | 487 | 0 | 0 | 0 | 23 | 14 | 31 | 149 | 80 | 196 | 30 | 29 | 47 | 50 | 50 | 79 | 56 | 57 | 90 | 26 | 22 | 39 | 3 | 1 | 4 | | | | | | | | | | | | | | | | | |
| Price escalation | 23 | 38 | 45 | 0 | 0 | 0 | 0 | 1 | 6 | 7 | 10 | 2 | 4 | 4 | 4 | 8 | 9 | 6 | 12 | 14 | 3 | 6 | 7 | 0 | 0 | 1 | | | | | | | | | | | | | | | | | | |
| Physical contingency | 18 | 15 | 27 | 0 | 0 | 0 | 1 | 1 | 2 | 8 | 4 | 10 | 2 | 2 | 3 | 3 | 3 | 4 | 3 | 3 | 5 | 1 | 1 | 2 | 0 | 0 | 0 | | | | | | | | | | | | | | | | | |
| Total (I + II) | 2,330 | 4,295 | 4,872 | 0 | 0 | 0 | 25 | 15 | 33 | 163 | 91 | 217 | 304 | 351 | 512 | 793 | 1,652 | 1,771 | 818 | 1,727 | 1,840 | 223 | 459 | 495 | 4 | 1 | 4 | | | | | | | | | | | | | | | | | |
| B. NON ELIGIBLE PORTION | | | | | | | | | | | | | | | | | | | | | | | | | | | | | | | | | | | | | | | | | | | | |
| a Installation of Distribution Sub. Service Connections | 12 | 97 | 69 | 0 | 0 | 0 | 0 | 0 | 0 | 0 | 0 | 0 | 0 | 0 | 0 | 5 | 42 | 30 | 5 | 44 | 31 | 1 | 11 | 8 | 0 | 0 | 0 | | | | | | | | | | | | | | | | | |
| Base cost | 10 | 77 | 56 | 0 | 0 | 0 | 0 | 0 | 0 | 0 | 0 | 0 | 0 | 0 | 0 | 4 | 34 | 25 | 4 | 34 | 25 | 1 | 9 | 6 | 0 | 0 | 0 | | | | | | | | | | | | | | | | | |
| Price escalation | 1 | 16 | 10 | 0 | 0 | 0 | 0 | 0 | 0 | 0 | 0 | 0 | 0 | 0 | 0 | 0 | 6 | 4 | 0 | 7 | 5 | 0 | 2 | 1 | 0 | 0 | 0 | | | | | | | | | | | | | | | | | |
| Physical contingency | 1 | 5 | 3 | 0 | 0 | 0 | 0 | 0 | 0 | 0 | 0 | 0 | 0 | 0 | 0 | 0 | 2 | 1 | 0 | 2 | 1 | 0 | 1 | 0 | 0 | 0 | 0 | | | | | | | | | | | | | | | | | |
| b Land Acquisition | 0 | 19 | 11 | 0 | 0 | 0 | 4 | 2 | 4 | 2 | 0 | 4 | 2 | 0 | 4 | 2 | 0 | 4 | 3 | 0 | 3 | 2 | 0 | 0 | 0 | 0 | 0 | | | | | | | | | | | | | | | | | |
| Base cost | 0 | 16 | 10 | 0 | 0 | 0 | 4 | 2 | 4 | 2 | 0 | 4 | 2 | 0 | 4 | 2 | 0 | 4 | 2 | 1 | 0 | 0 | 0 | 0 | 0 | 0 | 0 | | | | | | | | | | | | | | | | | |
| Price escalation | 0 | 2 | 1 | 0 | 0 | 0 | 0 | 0 | 0 | 0 | 0 | 0 | 0 | 0 | 0 | 0 | 1 | 0 | 0 | 1 | 0 | 0 | 0 | 0 | 0 | 0 | 0 | | | | | | | | | | | | | | | | | |
| Physical contingency | 0 | 1 | 1 | 0 | 0 | 0 | 0 | 0 | 0 | 0 | 0 | 0 | 0 | 0 | 0 | 0 | 0 | 0 | 0 | 0 | 0 | 0 | 0 | 0 | 0 | 0 | 0 | | | | | | | | | | | | | | | | | |
| c Administration cost | 0 | 753 | 446 | 0 | 0 | 0 | 5 | 3 | 33 | 20 | 0 | 78 | 46 | 0 | 274 | 162 | 0 | 285 | 169 | 0 | 76 | 45 | 0 | 1 | 0 | 1 | | | | | | | | | | | | | | | | | | |
| d VAT | 0 | 1,004 | 594 | 0 | 0 | 0 | 7 | 4 | 44 | 26 | 0 | 104 | 62 | 0 | 366 | 216 | 0 | 380 | 225 | 0 | 102 | 60 | 0 | 1 | 0 | 1 | | | | | | | | | | | | | | | | | | |
| e Import Tax | 0 | 895 | 530 | 0 | 0 | 0 | 0 | 0 | 0 | 0 | 0 | 0 | 124 | 73 | 0 | 338 | 200 | 0 | 345 | 204 | 0 | 88 | 52 | 0 | 0 | 0 | | | | | | | | | | | | | | | | | | |
| Total (a+b+c+d+e) | 12 | 2,769 | 1,651 | 0 | 0 | 0 | 17 | 10 | 82 | 48 | 0 | 310 | 184 | 5 | 1,025 | 612 | 5 | 1,057 | 631 | 1 | 278 | 166 | 0 | 2 | 1 | | | | | | | | | | | | | | | | | | | |
| TOTAL (A+B) | 2,341 | 7,064 | 6,523 | 0 | 0 | 0 | 25 | 31 | 43 | 163 | 173 | 265 | 304 | 661 | 695 | 798 | 2,676 | 2,383 | 823 | 2,783 | 2,471 | 224 | 737 | 661 | 4 | 3 | 5 | | | | | | | | | | | | | | | | | |
| C. Interest during Construction | | | | | | | | | | | | | | | | | | | | | | | | | | | | | | | | | | | | | | | | | | | | |
| Interest during Construction(Const.) | 252 | 0 | 252 | 0 | 0 | 0 | 0 | 0 | 0 | 0 | 0 | 0 | 10 | 0 | 10 | 36 | 0 | 36 | 62 | 0 | 62 | 70 | 0 | 70 | 74 | 0 | 74 | | | | | | | | | | | | | | | | | |
| Interest during Construction (Consul.) | 1 | 0 | 1 | 0 | 0 | 0 | 0 | 0 | 0 | 0 | 0 | 0 | 0 | 0 | 0 | 0 | 0 | 0 | 0 | 0 | 0 | 0 | 0 | 1 | 0 | 1 | | | | | | | | | | | | | | | | | | |
| D. Commitment Charge | 41 | 0 | 41 | 0 | 0 | 0 | 6 | 0 | 6 | 6 | 0 | 6 | 6 | 0 | 6 | 6 | 0 | 6 | 6 | 0 | 6 | 5 | 0 | 5 | 5 | 0 | 5 | | | | | | | | | | | | | | | | | |
| GRAND TOTAL (A+B+C+D) | 2,635 | 7,064 | 6,817 | 0 | 0 | 0 | 31 | 31 | 49 | 169 | 173 | 272 | 321 | 661 | 712 | 841 | 2,676 | 2,425 | 891 | 2,783 | 2,539 | 300 | 737 | 736 | 83 | 3 | 85 | | | | | | | | | | | | | | | | | |
| E. JICA finance portion incl. IDC (A + C + D) | 2,623 | 4,295 | 5,166 | 0 | 0 | 0 | 31 | 15 | 40 | 169 | 91 | 223 | 321 | 351 | 528 | 835 | 1,652 | 1,813 | 886 | 1,727 | 1,908 | 298 | 459 | 570 | 83 | 1 | 84 | | | | | | | | | | | | | | | | | |
| Administration Cost = 9% | | | | | | | | | | | | | | | | | | | | | | | | | | | | | | | | | | | | | | | | | | | | |
| VAT = 12% of the expenditure in local currency of the eligible portion | | | | | | | | | | | | | | | | | | | | | | | | | | | | | | | | | | | | | | | | | | | | |
| Import Tax = 27% | | | | | | | | | | | | | | | | | | | | | | | | | | | | | | | | | | | | | | | | | | | | |

Table 7.6 Wahalkada Disbursement Schedule (Stage-1)

| Annual Fund Requirement | | | | | | | | | | | | | | | | | | | | | | | | | | | | |
|---|--|--------|--------|-----------|----|-------|------|----|-------|------|----|-------|------|-----|-------|-------------------------|-------|-------|-------|-------|-------|-------|-------|-------|------|----|-------|---|
| Base Year for Cost Estimation: | | | | Oct, 2012 | | | | | | | | | | | | FC & Total: JPY million | | | | | | | | | | | | |
| Exchange Rates | | | | Rs. = Yen | | | | | | | | | | | | LC : Rs. million | | | | | | | | | | | | |
| Price Escalation: | | | | FC: 2.1% | | | | | | | | | | | | LC: 4.0% | | | | | | | | | | | | |
| Physical Contingency | | | | 5% | | | | | | | | | | | | | | | | | | | | | | | | |
| Physical Contingency for Consultant | | | | 5% | | | | | | | | | | | | | | | | | | | | | | | | |
| Item | Total | | | 2012 | | | 2013 | | | 2014 | | | 2015 | | | 2016 | | | 2017 | | | 2018 | | | 2019 | | | |
| | FC | LC | Total | FC | LC | Total | FC | LC | Total | FC | LC | Total | FC | LC | Total | FC | LC | Total | FC | LC | Total | FC | LC | Total | FC | LC | Total | |
| A. ELIGIBLE PORTION | | | | | | | | | | | | | | | | | | | | | | | | | | | | |
| I) Procurement / Construction | 3,489 | 5,868 | 6,963 | 0 | 0 | 0 | 0 | 0 | 0 | 0 | 0 | 0 | 417 | 424 | 669 | 1,063 | 1,825 | 2,144 | 1,085 | 1,938 | 2,233 | 923 | 1,680 | 1,918 | 0 | 0 | 0 | 0 |
| 1. Intake,WTP,Elevated Tanks and Grand Sumps | 1,033 | 2,549 | 2,543 | 0 | 0 | 0 | 0 | 0 | 0 | 0 | 0 | 0 | 84 | 207 | 206 | 335 | 827 | 825 | 335 | 827 | 825 | 279 | 689 | 687 | 0 | 0 | 0 | 0 |
| 2. Transmission and Distribution Main | 1,931 | 1,018 | 2,534 | 0 | 0 | 0 | 0 | 0 | 0 | 0 | 0 | 0 | 290 | 153 | 380 | 579 | 305 | 760 | 579 | 305 | 760 | 483 | 254 | 633 | 0 | 0 | 0 | 0 |
| 3. Distribution Sub System | 48 | 940 | 604 | 0 | 0 | 0 | 0 | 0 | 0 | 0 | 0 | 0 | 0 | 0 | 0 | 17 | 332 | 213 | 17 | 332 | 213 | 14 | 276 | 178 | 0 | 0 | 0 | 0 |
| 4. O&M Equipment | 0 | 121 | 72 | 0 | 0 | 0 | 0 | 0 | 0 | 0 | 0 | 0 | 0 | 0 | 0 | 0 | 22 | 13 | 0 | 54 | 32 | 0 | 45 | 27 | 0 | 0 | 0 | 0 |
| Base cost for JICA financing | 3,013 | 4,627 | 5,753 | 0 | 0 | 0 | 0 | 0 | 0 | 0 | 0 | 0 | 374 | 359 | 586 | 932 | 1,486 | 1,811 | 932 | 1,517 | 1,830 | 776 | 1,265 | 1,525 | 0 | 0 | 0 | 0 |
| Price escalation | 310 | 962 | 879 | 0 | 0 | 0 | 0 | 0 | 0 | 0 | 0 | 0 | 24 | 45 | 51 | 81 | 252 | 230 | 102 | 329 | 297 | 103 | 336 | 302 | 0 | 0 | 0 | 0 |
| Physical contingency | 166 | 279 | 332 | 0 | 0 | 0 | 0 | 0 | 0 | 0 | 0 | 0 | 20 | 20 | 32 | 51 | 87 | 102 | 52 | 92 | 106 | 44 | 80 | 91 | 0 | 0 | 0 | 0 |
| II) Consulting services | 175 | 298 | 352 | 0 | 0 | 0 | 0 | 0 | 0 | 0 | 0 | 0 | 9 | 33 | 29 | 28 | 70 | 69 | 33 | 84 | 83 | 101 | 110 | 166 | 4 | 1 | 5 | 0 |
| Base cost | 149 | 234 | 288 | 0 | 0 | 0 | 0 | 0 | 0 | 0 | 0 | 0 | 8 | 28 | 25 | 24 | 57 | 58 | 28 | 66 | 67 | 85 | 83 | 134 | 3 | 1 | 4 | 0 |
| Price escalation | 18 | 50 | 47 | 0 | 0 | 0 | 0 | 0 | 0 | 0 | 0 | 0 | 1 | 3 | 3 | 2 | 10 | 8 | 3 | 14 | 12 | 11 | 22 | 24 | 0 | 0 | 1 | 0 |
| Physical contingency | 8 | 14 | 17 | 0 | 0 | 0 | 0 | 0 | 0 | 0 | 0 | 0 | 0 | 2 | 1 | 1 | 3 | 3 | 2 | 4 | 4 | 5 | 5 | 8 | 0 | 0 | 0 | 0 |
| Total (I + II) | 3,664 | 6,166 | 7,315 | 0 | 0 | 0 | 0 | 0 | 0 | 0 | 0 | 0 | 427 | 457 | 697 | 1,091 | 1,895 | 2,213 | 1,118 | 2,023 | 2,316 | 1,025 | 1,790 | 2,084 | 4 | 1 | 5 | 0 |
| B. NON ELIGIBLE PORTION | | | | | | | | | | | | | | | | | | | | | | | | | | | | |
| a Installation of Distribution Sub. Service Connections | 14 | 122 | 86 | 0 | 0 | 0 | 0 | 0 | 0 | 0 | 0 | 0 | 0 | 0 | 0 | 5 | 41 | 29 | 5 | 43 | 30 | 4 | 37 | 26 | 0 | 0 | 0 | 0 |
| Base cost | 12 | 95 | 69 | 0 | 0 | 0 | 0 | 0 | 0 | 0 | 0 | 0 | 0 | 0 | 0 | 4 | 34 | 24 | 4 | 34 | 24 | 4 | 28 | 20 | 0 | 0 | 0 | 0 |
| Price escalation | 1 | 20 | 13 | 0 | 0 | 0 | 0 | 0 | 0 | 0 | 0 | 0 | 0 | 0 | 0 | 0 | 6 | 4 | 0 | 7 | 5 | 0 | 7 | 5 | 0 | 0 | 0 | 0 |
| Physical contingency | 1 | 6 | 4 | 0 | 0 | 0 | 0 | 0 | 0 | 0 | 0 | 0 | 0 | 0 | 0 | 0 | 2 | 1 | 0 | 2 | 1 | 0 | 2 | 1 | 0 | 0 | 0 | 0 |
| b Land Acquisition | 0 | 10 | 6 | 0 | 0 | 0 | 0 | 0 | 0 | 0 | 0 | 0 | 0 | 0 | 0 | 0 | 6 | 4 | 0 | 4 | 3 | 0 | 0 | 0 | 0 | 0 | 0 | 0 |
| Base cost | 0 | 8 | 5 | 0 | 0 | 0 | 0 | 0 | 0 | 0 | 0 | 0 | 0 | 0 | 0 | 0 | 5 | 3 | 0 | 3 | 2 | 0 | 0 | 0 | 0 | 0 | 0 | 0 |
| Price escalation | 0 | 2 | 1 | 0 | 0 | 0 | 0 | 0 | 0 | 0 | 0 | 0 | 0 | 0 | 0 | 0 | 1 | 1 | 0 | 1 | 0 | 0 | 0 | 0 | 0 | 0 | 0 | 0 |
| Physical contingency | 0 | 0 | 0 | 0 | 0 | 0 | 0 | 0 | 0 | 0 | 0 | 0 | 0 | 0 | 0 | 0 | 0 | 0 | 0 | 0 | 0 | 0 | 0 | 0 | 0 | 0 | 0 | 0 |
| c Administration cost | 0 | 1,126 | 667 | 0 | 0 | 0 | 0 | 0 | 0 | 0 | 0 | 0 | 106 | 63 | 0 | 341 | 202 | 0 | 357 | 211 | 0 | 321 | 190 | 0 | 1 | 0 | 0 | 0 |
| d VAT | 0 | 1,501 | 889 | 0 | 0 | 0 | 0 | 0 | 0 | 0 | 0 | 0 | 141 | 84 | 0 | 455 | 269 | 0 | 476 | 282 | 0 | 428 | 253 | 0 | 1 | 1 | 0 | 0 |
| e Import Tax | 0 | 1,598 | 946 | 0 | 0 | 0 | 0 | 0 | 0 | 0 | 0 | 0 | 190 | 113 | 0 | 487 | 288 | 0 | 497 | 294 | 0 | 423 | 250 | 0 | 0 | 0 | 0 | 0 |
| Total (a+b+c+d+e) | 14 | 4,358 | 2,594 | 0 | 0 | 0 | 0 | 0 | 0 | 0 | 0 | 0 | 438 | 259 | 5 | 1,331 | 793 | 5 | 1,378 | 821 | 4 | 1,209 | 720 | 0 | 2 | 1 | 0 | 0 |
| TOTAL (A+B) | 3,679 | 10,524 | 9,909 | 0 | 0 | 0 | 0 | 0 | 0 | 0 | 0 | 0 | 427 | 895 | 956 | 1,096 | 3,226 | 3,006 | 1,123 | 3,400 | 3,136 | 1,029 | 2,999 | 2,805 | 4 | 3 | 6 | 0 |
| C. Interest during Construction | 320 | 0 | 320 | 0 | 0 | 0 | 0 | 0 | 0 | 0 | 0 | 0 | 9 | 0 | 9 | 40 | 0 | 40 | 71 | 0 | 71 | 99 | 0 | 99 | 101 | 0 | 101 | 0 |
| Interest during Construction(Const.) | 320 | 0 | 320 | 0 | 0 | 0 | 0 | 0 | 0 | 0 | 0 | 0 | 9 | 0 | 9 | 40 | 0 | 40 | 71 | 0 | 71 | 99 | 0 | 99 | 101 | 0 | 101 | 0 |
| Interest during Construction (Consul.) | 0 | 0 | 0 | 0 | 0 | 0 | 0 | 0 | 0 | 0 | 0 | 0 | 0 | 0 | 0 | 0 | 0 | 0 | 0 | 0 | 0 | 0 | 0 | 0 | 0 | 0 | 0 | 0 |
| D. Commitment Charge | 61 | 0 | 61 | 0 | 0 | 0 | 9 | 0 | 9 | 9 | 0 | 9 | 9 | 0 | 9 | 9 | 0 | 9 | 9 | 0 | 9 | 8 | 0 | 8 | 8 | 0 | 8 | 0 |
| GRAND TOTAL (A+B+C+D) | 4,060 | 10,524 | 10,290 | 0 | 0 | 0 | 9 | 0 | 9 | 9 | 0 | 9 | 445 | 895 | 975 | 1,144 | 3,226 | 3,054 | 1,204 | 3,400 | 3,217 | 1,136 | 2,999 | 2,911 | 112 | 3 | 114 | 0 |
| E. JICA finance portion incl. IDC (A + C + D) | 4,045 | 6,166 | 7,696 | 0 | 0 | 0 | 9 | 0 | 9 | 9 | 0 | 9 | 445 | 457 | 716 | 1,139 | 1,895 | 2,261 | 1,199 | 2,023 | 2,396 | 1,132 | 1,790 | 2,191 | 112 | 1 | 113 | 0 |
| Administration Cost = | 9% | | | | | | | | | | | | | | | | | | | | | | | | | | | |
| VAT = | 12% of the expenditure in local currency of the eligible portion | | | | | | | | | | | | | | | | | | | | | | | | | | | |
| Import Tax = | 27% | | | | | | | | | | | | | | | | | | | | | | | | | | | |

Note: The Project cost will be discussed and finalised in the Appraisal of Wahalkada Scheme.

7.4.1 Eligible Cost

(1) Construction Cost

The summary of construction cost is tabulated as shown in **Table 7.7**.

Table 7.7 Construction Cost per Package (Stage-1)

Yen in Million and RS. in Million

| Package | Description | FC | LC | Total |
|-----------------------|---|--------------|--------------|--------------|
| | | (JPY) | (Rs.) | (JPY) |
| Mahakanadarawa | | | | |
| 1 | Intake,WTP,Elevated Tanks and Grand Sumps | 708 | 1,697 | 1,712 |
| 2 | Transmission and Distribution Main* | 944 | 540 | 1,263 |
| 3 | Distribution Sub System | 43 | 829 | 534 |
| 4 | O&M Equipment | 0 | 115 | 68 |
| Price escalation | | 164 | 620 | 531 |
| Physical contingency | | 93 | 190 | 205 |
| Total | | 1,951 | 3,990 | 4,314 |
| Wahalkada | | | | |
| 1 | Intake,WTP,Elevated Tanks and Grand Sumps | 1,033 | 2,549 | 2,543 |
| 2 | Transmission and Distribution Main* | 1,931 | 1,018 | 2,534 |
| 3 | Distribution Sub System | 48 | 940 | 604 |
| 4 | O&M Equipment | 0 | 121 | 72 |
| Price escalation | | 310 | 962 | 879 |
| Physical contingency | | 166 | 279 | 332 |
| Total | | 3,489 | 5,868 | 6,963 |

Note: The cost of Wahalkada Scheme will be discussed and finalised in the Appraisal.

(2) Water Browsers and Tanks in Isolated Area

To supply water to the isolated area defined and explained in Chapter 5 previously, water browsers and elevated water tanks are proposed in this project. This portion is very critical component to fulfil this project mission of distributing the quality and safe water to people in the Anuradhapura North area. The total estimated cost for supplying water to isolated areas using water browsers and tanks in this project is approximately Rs. 180.7 million. The water tanks and water browsers are included as a part of the following packages:

Mahakanadarawa

- 5 m³ Elevated Water Tanks , Rs. 25 million in Package 3
- 5 m³ Water Browsers, Rs. 57.24 million in “Vehicles” of Package 4

Wahalkada

- 5 m³ Elevated Water Tanks, Rs. 28.5 million included in Package 3:
- 5 m³ Water Bowsers, Rs. 69.96 million included in “Vehicles” of Package 4

In consideration of cost effectiveness and procurement schedule, the activity is recommended not to be divided into Mahakanadarawa and Wahalkada to keep a flow of activities simple and smooth.

A summary table of the water bowsers and elevated water tank is as shown in **Table 7.8**.

Table 7.8 Cost for Water Bowsers and Water Elevated Tanks in the Isolated Area

| Station | 5m ³ Water Tank | | 5m ³ Water Bowser | |
|--|----------------------------|-----------------------|------------------------------|-----------------------|
| | ea | Cost (Rs. Million) | ea | Cost (Rs. Million) |
| Mahakadarawa | | | | |
| Medewachchiya | 15 | | 3 | |
| Rembewa | 35 | | 6 | |
| Sub-total | 50 | 25 | 9 | 57.24 |
| Wahalkada | | | | |
| Bogohawewa | 16 | | 3 | |
| Weelasol | 6 | | 1 | |
| West Horowpothana | 8 | | 2 | |
| Kahatasdigiliya | 28 | | 5 | |
| Sub-total | 57 | 28.5 | 11 | 69.96 |
| Total | 168 | 53.5 | 20 | 127.2 |
| Ground Total (Water Tank + Water Bowser) | | | | 180.7 |

(3) Consulting Services

The consulting services include 1) detailed designs, 2) tender process assistance, 3) construction supervision, 4) facilitation of implementation of Environmental Management Plan (EMP), Environmental Monitoring Plan (EMoP) and Resettlement Action Plan (RAPEMP), 5) technology transfer on construction supervision of proposed water supply facilities, 6) training for capacity development of NWSDB’s staff, and 7) guidance for public awareness campaign of Anuradhapura North Integrated Water Supply Project. This will consist of both international and local professionals and local supportive and administrative staffs to fulfill the project tasks. The foreign professionals are necessary to be a part of the project to share their expertise and knowledge with the local professionals. The local professional and supportive and administrative staff will be able to contribute more efficient process to the project since the local staff are much more familiar with the local procedures and regulations by utilizing existing

networks with government and local authorities.

The detailed engineering design consists of water intake, water treatment plants, transmission pipe lines, distribution pipe mains, distributions sub-mains, ground reservoirs, elevated water tanks, and all other related works including road and pipe water bridges in Mahakanadarawa and Wahalkada areas. In addition, it will include preparation of detailed technical specification and tender document, construction supervision, and technology transfer on construction supervision during the construction for all packages mentioned in other sections.

During preparation of the tender document, the following matters relating to the construction activities shall be addressed: 1) sorting demolishing and recycling materials onsite or offsite, 2) monitoring and controlling runoff from the construction activities, 3) monitoring and controlling noise and vibration from the construction activities, 4) providing safe environment for workers to work and neighbors to live, including not limited to, providing safety tools and proper barriers for encompassing the construction site. Therefore, the cost associated with these activities will be properly included to bidding costs prepared by contractors.

The consulting services for facilitation of implementation of EMP, EMoP, and RAP consists of updating the EMP, assisting to identify the environmental responsibilities in the preparation of bidding documents, updating RAP as necessary, assessing the social impacts and prepare social development plans to address the identified impacts, monitor land acquisition and compensation activities being undertaken by NWSDB and other authorities by preparing monthly progress reports, supervising EMP implementation and monitoring works to ensure in accordance with the EMP, and assisting NWSDB in the capacity building of NWSDB staff on environmental management through trainings.

The consulting service for capacity building and development consists of conceptualizing and developing the training plans for NWSDB RSC (NC) and conducting the actual training based on the organized plans.

The consulting service for public awareness campaign consists of informing and educating the general public of the present situation of health damage in the project area caused by the use of groundwater, the objectives of the proposed project, the importance of connection to a proposed water supply system under the project and payment of water tariff for sustainable operation and management of water supply facilities through collecting data, analyzing the data, preparing reports and conducting seminars and public campaigns.

A total cost estimation of all consulting services mentioned above as follows:

- 1) Mahakanadarawa: 559 million yen
(Foreign portion: 378 million yen, Local portion: Rs. 305 million)
- 2) Wahalkada: 352 million yen (Will be discussed and finalised in the Appraisal)

(Foreign portion: 175 million yen, Local portion: Rs. 298 million)

This total consulting service cost includes as follows:

- 1) Mahakanadarawa: 396 man-months of foreign and local experts
760 man-months of additional supporting staffs
- 2) Wahalkada: 260 man-months of foreign and local expert
674 man-months of additional supporting staffs.

The expected cost items of the consulting services are shown in **Table 7.9** for the Detailed Design Consultant Services and Project Management Services.

Table 7.9 Mahakanadarawa Estimated Cost for Consulting Services (Stage-1)

USD 1 = JPY 78.2 Rs. 1 = JPY 0.592

| | | Unit | Qty. | Foreign Portion | | Local Portion | | Combined Total |
|----------|-------------------------------|-------|------|-----------------|----------------|---------------|----------------|----------------|
| | | | | (JPY '000)) | | (Rs. '000) | | (JPY '000)) |
| | | | | Rate | Amount | Rate | Amount | |
| A | Remuneration | | | | | | | |
| 1 | Professional (A) | M/M | 85 | 2,562,000 | 217,770 | | 0 | 217,770 |
| 2 | Professional (B) | M/M | 311 | | 0 | 350,000 | 108,850 | 64,439 |
| 3 | Supporting Staffs | M/M | 760 | | 0 | 93,026 | 70,700 | 41,854 |
| | Subtotal of A | | | | 217,770 | | 179,550 | 324,064 |
| B | Direct Cost | | | | | | | |
| 1 | International Airfare-1 | | 13 | 350,000 | 4,550 | | | 4,550 |
| 2 | International Airfare-2 | | 29 | | 0 | 250,000 | 7,250 | 4,292 |
| 3 | Domestic Travel | | 0 | 5,000 | 0 | | 0 | 0 |
| 4 | Accom. Allowance_A-1 | Month | 42 | 300,000 | 12,600 | | 0 | 12,600 |
| | Accom. Allowance_A-2 | Month | 43 | 150,000 | 6,450 | | 0 | 6,450 |
| | Travelling Allowance_B | Month | 0 | | 0 | 10,000 | 0 | 0 |
| 5 | Vehicle Rental | Month | 300 | | 0 | 200,000 | 60,000 | 35,520 |
| 6 | Office Rental | M/M | 20 | | 0 | 300,000 | 6,000 | 3,552 |
| 7 | International Communications | M/M | 70 | 50,000 | 3,500 | | 0 | 3,500 |
| 8 | Domestic Communications | M/M | 70 | 10,000 | 700 | | 0 | 700 |
| 9 | Office Supply | M/M | 70 | 100,000 | 7,000 | | 0 | 7,000 |
| 10 | Office Furniture and Equip | LS | 1 | 2,220,000 | 2,220 | | 0 | 2,220 |
| 11 | Report Preparation | LS | 0 | 370,000 | 0 | | 0 | 0 |
| 12 | Topographic Survey | LS | 1 | 21,312,000 | 21,312 | | 0 | 21,312 |
| 13 | Geographic Survey | LS | 1 | 3,700,000 | 3,700 | | 0 | 3,700 |
| 14 | Water Quality Survey | LS | 1 | 222,000 | 222 | | 0 | 222 |
| 15 | Supply of software w/ license | LS | 1 | 10,000,000 | 10,000 | | 0 | 10,000 |
| 16 | Provisional Sum | LS | 1 | 20,000,000 | 40,000 | | 0 | 40,000 |
| 17 | Home Office Support | M/M | 70 | 100,000 | 7,000 | | 0 | 7,000 |
| | Subtotal of B | | | | 119,254 | | 73,250 | 162,618 |
| | Grand Total | | | | 337,024 | | 252,800 | 486,682 |

Table 7.10 Wahalkada Estimated Cost for Consulting Services (Stage-2)

USD 1 = JPY 78.2 Rs. 1 = JPY 0.592

| | | Unit | Qty. | Foreign Portion | | Local Portion | | Combined Total |
|--------------------|------------------------------|-------|------|-----------------|----------------|---------------|----------------|----------------|
| | | | | (JPY '000)) | | (Rs. '000) | | (JPY '000)) |
| | | | | Rate | Amount | Rate | Amount | |
| A | Remuneration | | | | | | | |
| 1 | Professional (A) | M/M | 27 | 2,562,000 | 69,174 | | 0 | 69,174 |
| 2 | Professional (B) | M/M | 233 | | 0 | 350,000 | 81,550 | 48,278 |
| 3 | Supporting Staffs | M/M | 674 | | 0 | 94,214 | 63,500 | 37,592 |
| Subtotal of A | | | | | 69,174 | | 145,050 | 155,044 |
| B | Direct Cost | | | | | | | |
| 1 | International Airfare-1 | | 1 | 350,000 | 350 | | | 350 |
| 2 | International Airfare-2 | | 7 | | 0 | 250,000 | 1,750 | 1,036 |
| 3 | Domestic Travel | | 0 | 5,000 | 0 | | 0 | 0 |
| 4 | Accom. Allowance_A-1 | Month | 8 | 300,000 | 2,400 | | 0 | 2,400 |
| | Accom. Allowance_A-2 | Month | 19 | 150,000 | 2,850 | | 0 | 2,850 |
| | Travelling Allowance_B | Month | 0 | | | 10,000 | 0 | 0 |
| 5 | Vehicle Rental | Month | | | 0 | | 0 | 0 |
| 6 | Office Rental | M/M | 437 | | | 200,000 | 87,400 | 51,741 |
| 7 | International Communications | M/M | 0 | | | 300,000 | 0 | 0 |
| 8 | Domestic Communications | M/M | 42 | 50,000 | 2,100 | | 0 | 2,100 |
| 9 | Office Supply | M/M | 42 | 10,000 | 420 | | 0 | 420 |
| 10 | Office Furniture and Equip | LS | 42 | 100,000 | 4,200 | | 0 | 4,200 |
| 11 | Report Preparation | LS | 0 | 3,780,000 | 0 | | 0 | 0 |
| 12 | Topographic Survey | LS | 1 | 36,288,000 | 36,288 | | 0 | 36,288 |
| 13 | Geographic Survey | LS | 1 | 6,300,000 | 6,300 | | 0 | 6,300 |
| 14 | Water Quality Survey | LS | 1 | 378,000 | 378 | | 0 | 378 |
| 15 | Provisional Sum | LS | 1 | 20,000,000 | 20,000 | | 0 | 20,000 |
| 16 | Home Office Support | M/M | 42 | 100,000 | 4,200 | | 0 | 4,200 |
| Subtotal of B | | | | | 80,116 | | 89,150 | 132,893 |
| Grand Total | | | | | 149,290 | | 234,200 | 287,936 |

Note: The cost of Wahalkada Scheme will be discussed and finalised in the Appraisal.

7.4.2 Non-Eligible Cost

(1) Land Acquisition

Land acquisition for the proposed water facilities of this project is situated on two different types of lands, private and public lands. Each type of land has a different process to acquire for proposed water facilities uses and explained more details in Chapter 9. The private land is required to be purchased with the acquisition process set forth by Sri Lanka Land Acquisition Act 1950, No. 9. Since public land in Sri Lanka is known as “common” land for common benefits, the process and condition are different from that for the private land. Generally, public land

(common land) is allowed to be leased from Sri Lanka Government with annual fee after successful completing the leasing process overseen by multiple Sri Lanka governmental departments according to Assessment Department in NWSDB Anuradhapura office. The total estimated cost for land acquisition with this project is approximately Rs. 25 Million (Mahakanadarawa = Rs. 16.47 Million, Wahalkada = Rs. 8.4 Million). The activities associated with Land Acquisition will be started when the Mahakanadarawa portion of the project starts. In consideration of cost effectiveness and schedule, the activity is recommended not to be divided into Mahakanadarawa and Wahalkada to keep a flow of activities simple and smooth. The cost associated with Land Acquisition is included only to Mahakanadarawa.

A summary table of the proposed water facilities, which require land acquisition is as shown in **Table 7.11**.

Table 7.11 Estimated Cost for Proposed Land Acquisition/ Resettlement

| Land Type | Estimated Area | Land Acquisition Type | Estimated Cost |
|--|----------------|-----------------------|----------------|
| | Ac | | (Rs. Million) |
| Mahakanadarawa | | | |
| 1. Land Acquisition | | | |
| Public | 13.0 | Lease | 5.2 |
| Private | 2.2 | Purchase | 7.3 |
| NWSDB | 0.0 | Lease | 0.0 |
| Sub-Total | 15.2 | | 12.5 |
| 2. Resettlement (moving from the Mahakanadarawa WTP proposed property to private land) | | | |
| Private | 0.02 | Purchase | 0.07 |
| Resettlement (including new house, utilities connections, moving cost, and rental allowance) | | | 3.9 |
| Sub-Total | 0.02 | | 3.97 |
| Total (Maha) | 15.22 | | 16.47 |
| Wahalkada | | | |
| 1. Land Acquisition | | | |
| Public | 17.0 | Lease | 6.8 |
| Private | 0.0 | Purchase | 0.0 |
| NWSDB | 4.0 | Lease | 1.6 |
| Total (Waha) | 21.0 | | 8.4 |

Notes: In Sri Lanka, land value is evaluated by Valuation Department in each Regional Office and the process will take place after the commencement of the project.

(2) Distribution Sub System (PVC 50 mm) and Service Connections

Installation of Distribution Sub System (PVC 50 mm) and Service Connections from closest distribution sub main pipes to water meters for residential houses are a part of the NWSDB funds

as non-eligible portion of this project. The installation of the PVCs with a diameter smaller than or equivalent to 50 mm in the Distribution Sub System and both the installation and supply of Service Connections are subjected to be covered by NWSDB funds.

Table 7.12 Distribution Sub System and Service Connections

| | FC (JPY Million) | LC (Rs. Million) | FC (JPY Million) |
|-----------------------|------------------|------------------|------------------|
| Mahakanadarawa | | | |
| Base Cost | 10 | 77 | 56 |
| Price Escalation | 1 | 16 | 10 |
| Physical Contingency | 1 | 5 | 3 |
| Total | 12 | 97 | 69 |
| Wahalkada | | | |
| Base Cost | 12 | 95 | 69 |
| Price Escalation | 1 | 20 | 13 |
| Physical Contingency | 1 | 6 | 4 |
| Total | 14 | 122 | 86 |

7.5 Operation and Maintenance Cost

(1) Current Operation and Maintenance

In 2011, NWSDB (NC) produced 18.74 million m³ of drinking water in the North Central Province (Anuradhapura and Polonnaruwa Districts). The operating expenses were categorized into 1) salary, 2) utility, 3) chemical, 4) extension/new connection, 5) repair/maintenance, 6) establishment, 7) security/rent. The annual operating expenses in 2011 are summarized in the following table.

The same cost information is available for Thuruwila Water treatment plant. The plant where applies rapid sand filtration process and produced 5.35 million m³ of drinking water in 2011.

Table 7.13 Operation and Maintenance NWSDB (NC) and Thuruwila WTP in 2011

| Description | NWSDB (NC) | | | Thuruwila WTP | | |
|----------------------------------|---|-----------------------------------|----------------|---|-----------------------------------|----------------|
| | Production (mill. m ³ /y) | Unit Cost (Rs/m ³) | Ratio | Production (mill. m ³ /y) | Unit Cost (Rs/m ³) | Ratio |
| | 18.74 | | | 5.35 | | |
| Perm./Casual Salarie | 122,687,437 | 6.55 | 28.28% | 2,035,099 | 0.38 | 6.18% |
| Overtime | 26,306,862 | 1.40 | 6.06% | 518,663 | 0.10 | 1.57% |
| Others | 19,445,789 | 1.04 | 4.48% | 279,890 | 0.05 | 0.85% |
| EPF,ETF | 18,171,642 | 0.97 | 4.19% | 300,090 | 0.06 | 0.91% |
| Medical Expences | 1,098,373 | 0.06 | 0.25% | 4,553 | 0.00 | 0.01% |
| Total Salary Cost | 187,710,103 | 10.02 | 43.27% | 3,138,295 | 0.59 | 9.53% |
| Utilities,Electricity | 87,579,809 | 4.67 | 20.19% | 17,309,342 | 3.24 | 52.54% |
| Others | 1,492,477 | 0.08 | 0.34% | 1,102,350 | 0.21 | 3.35% |
| Total Utility Cost | 89,072,286 | 4.75 | 20.53% | 18,411,692 | 3.44 | 55.88% |
| Chemical chlorine | 11,440,053 | 0.61 | 2.64% | 2,175,000 | 0.41 | 6.60% |
| Alum, Lime | 13,970,050 | 0.75 | 3.22% | 5,891,367 | 1.10 | 17.88% |
| Bleaching Powder | 1,070,449 | 0.06 | 0.25% | 11,908 | 0.00 | 0.04% |
| Other Chemicals | 675,891 | 0.04 | 0.16% | 389,886 | 0.07 | 1.18% |
| Total Chemical Cost | 27,156,443 | 1.45 | 6.26% | 8,468,161 | 1.58 | 25.70% |
| Extension Cost | 9,700,760 | 0.52 | 2.24% | 0 | 0.00 | 0.00% |
| New Connection Materi | 16,079,677 | 0.86 | 3.71% | 0 | 0.00 | 0.00% |
| Defective Metre Cost | 6,430,914 | 0.34 | 1.48% | 0 | 0.00 | 0.00% |
| Others | 196,865 | 0.01 | 0.05% | 0 | 0.00 | 0.00% |
| Total Cost | 32,408,216 | 1.73 | 7.47% | 0 | 0.00 | 0.00% |
| Repair & Maintanance | 31,068,927 | 1.66 | 7.16% | 499,404 | 0.09 | 1.52% |
| Total Cost | 31,068,927 | 1.66 | 7.16% | 499,404 | 0.09 | 1.52% |
| Estabilishment ,Printi | 1,944,599 | 0.10 | 0.45% | 1,353 | 0.00 | 0.00% |
| Subsistence | 3,671,557 | 0.20 | 0.85% | 112,807 | 0.02 | 0.34% |
| Vehicle Running | 7,439,021 | 0.40 | 1.71% | 17,590 | 0.00 | 0.05% |
| Telephone etc. | 4,603,491 | 0.25 | 1.06% | 89,692 | 0.02 | 0.27% |
| Total Estabilishment Cost | 17,658,668 | 0.94 | 4.07% | 221,442 | 0.04 | 0.67% |
| Security,Rent etc. | 35,151,859 | 1.88 | 8.10% | 2,208,230 | 0.41 | 6.70% |
| Fianance Charges | 13,559,260 | 0.72 | 3.13% | 0 | 0.00 | 0.00% |
| Total Other Cost | 48,711,119 | 2.60 | 11.23% | 2,208,230 | 0.41 | 6.70% |
| Total Operating Expenses | 433,785,762 | 23.15 | 100.00% | 32,947,224 | 6.16 | 100.00% |

The cost of operation and maintenance were obtained from the above data.

Table 7.14 Electricity and Chemical Consumption per Cubic Meter

| O&M Cost (Rs/m ³) | NWSDB (NC) | Water Treatment Plant |
|-------------------------------|-------------------------|-----------------------|
| | All Water Supply System | |
| Electricity | 4.67 | 3.24 |
| Chemical - Chlorine | 0.61 | 0.41 |
| Chemical - Alum, Lime | 0.75 | 1.10 |
| Repair & Maintenance | 1.66 | 0.09 |

(2) Salary Cost

As described in Chapter 6, new organization is proposed for management, operation and maintenance of proposed water supply system.

Table 7.15 Salary of Staff required for the Proposed Water Supply System

| Mahakanadarawa | | | | Wahalkada | | | |
|---------------------------|-----|--------------|-----------|---------------------------|-----|--------------|-----------|
| Location | No. | Basic Salary | Allowance | Location | No. | Basic Salary | Allowance |
| Mahakanadarawa | 10 | 225,733 | 52,000 | Wahalkada | 10 | 223,995 | 52,000 |
| Rambewa | 10 | 149,106 | 52,000 | Kahatagasdigiliya | 10 | 180,644 | 46,800 |
| Area Engineer's Office | 10 | 121,044 | 26,000 | Kebithigollewa | 10 | 159,800 | 41,600 |
| Medawachchiya | 10 | 119,850 | 31,200 | Sub-Total | 30 | 564,439 | 140,400 |
| Sub-Total | 40 | 615,733 | 161,200 | Total Monthly Salary | | 704,839 | |
| Total Monthly Salary | | 776,933 | | Overtime | | 179,613 | |
| Overtime | | 197,984 | | Others | | 96,941 | |
| Others | | 106,856 | | EPR/ETF | | 103,937 | |
| EPR/ETF | | 114,568 | | Total Monthly Salary Cost | | 1,085,329 | |
| Total Monthly Salary Cost | | 1,196,342 | | Total Annual Salary Cost | | 13,023,953 | |
| Total Annual Salary Cost | | 14,356,100 | | | | | |

Note: The above number of staff shall be assigned for the operation and maintenance of the systems. The salary cost shall be fixed cost.

(3) Electricity

Electricity is a variable cost related to the volume of water for production/distribution.

Table 7.16 Electricity Consumption for the Proposed Water Supply System

| O&M Cost (Rs/m ³) | | Mahakanadarawa | Wahalkada |
|---|---------|----------------|-----------|
| Daily Average Water Consumption (m ³ /d) | Stage 1 | 7,500 | 11,400 |
| | Stage 2 | 14,900 | 22,900 |
| Electricity (million Rs/year) | Stage 1 | 28.84 | 69.73 |
| | Stage 2 | 72.24 | 149.62 |
| Electricity (Rs/m ³) | Stage 1 | 10.54 | 16.76 |
| | Stage 2 | 13.32 | 17.90 |

The above electricity (Rs/m³) is calculated for each water supply system and at each stage. Electricity consumption per cubic meter of water for Wahalkada System is higher than that for Mahakanadarawa, because Wahalkada WTP is located at a lower elevation.

(4) Chemicals

Chemical cost is variable cost relating to volume of water for production/distribution.

Table 7.17 Chemical Consumption for the Proposed Water Supply System

| O&M Cost (Rs/m ³) | Mahakanadarawa/ Wahalkada |
|-------------------------------|------------------------------|
| Chemical - Chlorine | 0,61 |
| Chemical - Alum, Lime | 1.10 |

Cost of chlorine consumption is applied in "All Water Supply System in NWSDB (NC)" in the above **Table 7.13** Electricity and **Table 7.14** Chemical Consumption per Cubic Meter. It can be the typical cost for chlorine consumption in the water distribution system, while cost of alum/lime consumption in Water Treatment Plant was applied, because it is more accurate cost.

(5) Repair and Maintenance Cost

The average repair and maintenance cost per cubic meter in NWSDB (NC) is Rs1.66/m³. However, more intensive maintenance, including preventive maintenance is required. Therefore the repair and maintenance cost will be roughly doubled.

Table 7.18 Repair and Maintenance Cost for the Proposed Water Supply System

| O&M Cost (Rs/m ³) | Mahakanadarawa/ Wahalkada |
|-------------------------------|------------------------------|
| Repair & Maintenance | 3.00 |

(6) Operation and Maintenance Cost

The following table summarizes the operation and maintenance cost.

Table 7.19 Operation and Maintenance Cost for the Proposed Water Supply System

| O&M Cost (Rs/m ³) | | Mahakanadarawa | | Wahalkada | |
|-------------------------------|-------------------|----------------|---------|------------|---------|
| | | Stage 1 | Stage 2 | Stage1 | Stage 2 |
| Water Consumption | m ³ /d | 7,500 | 14,900 | 11,400 | 22,900 |
| Salary | Rs/year | 14,356,100 | | 13,023,953 | |
| Electricity | Rs/m ³ | 10.54 | 13.32 | 16.76 | 17.90 |
| Chemical - Chlorine | Rs/m ³ | 0,61 | | 0,61 | |
| Chemical - Alum, Lime | Rs/m ³ | 1.10 | | 1.10 | |
| Repair & Maintenance | Rs/m ³ | 3.00 | | 3.00 | |

CHAPTER 8 IMPLEMENTATION PLAN

8.1 Project Implementation Schedule

The expected overall schedule is shown in **Figure 8.1**. In preparing the overall schedule, following was considered for pre-construction and construction stages.

Two JICA Loan Packages will be applied for this Project. One package consists of the detailed design of both Mahakanadarawa and Wahalkada Water Supply Systems and construction of Mahakanadarawa Water Supply System. The other package consists of the construction of Wahalkada Water Supply System.

Table 8.1 Proposed Project Implementation Schedule

| Description | Schedule |
|--|---|
| Pledge of JICA Loan | December 2012 |
| Exchange of Notes between GOB and GOJ | March 2013 |
| Signing of Loan Agreement (Mahakanadarawa Stage-1) | March 2013 |
| Signing of Loan Agreement (Wahalkada Stage-1) | N/A |
| Selection of consultant for Designing & Construction Supervision | 8 months |
| Detailed Engineering Design, Preparation of specifications | 10 months |
| Contractor Prequalification (P/Q), evaluation and JICA concurrence | 7 months |
| Tender documents for individual project components, JICA concurrence on tender documents | 2 months |
| Project Tender period | 2 months |
| Evaluation of tender proposals | 2 months |
| JICA concurrence on tender evaluation (Contractor proposals) | 1 month |
| Contract negotiation | 1.5 months |
| JICA concurrence on contract award | 0.5 month |
| L/C Issuance for project | 1 month |
| Total period of Construction Work (Mahakanadarawa) | 33 months |
| Completion of the Project and Plant trials (Mahakanadarawa) | March 2018 |
| Total period of Construction Work (Wahalkada) | 36 months |
| Completion of the Project and Plant trials (Wahalkada) | October 2018 ^{*1} |
| O&M Training | 4 months (December 2017 to March 2018) |

Note: ^{*1} Implementation schedule will be discussed and finalised in the Appraisal of Wahalkada Scheme.

Implementation of the Project will consist of the six major processes:

- 1) Preparation of finances
- 2) Selection of the consultant for detailed design and construction supervision
- 3) Preparation of tender documents and detailed design
- 4) Tender of build-operate contractors/consortiums
- 5) Construction and commissioning

6) Supervision of O&M activities for the initial year by consultant (advisory role)

| | 2012 | | | | 2013 | | | | 2014 | | | | 2015 | | | | 2016 | | | | 2017 | | | | 2018 | | | | 2019 | | | | Week |
|--|------|---|---|---|------|---|---|---|------|---|---|---|------|---|---|---|------|---|---|---|------|---|---|---|------|---|---|---|------|---|---|---|-------|
| | 1 | 2 | 3 | 4 | 1 | 2 | 3 | 4 | 1 | 2 | 3 | 4 | 1 | 2 | 3 | 4 | 1 | 2 | 3 | 4 | 1 | 2 | 3 | 4 | 1 | 2 | 3 | 4 | 1 | 2 | 3 | 4 | |
| Appraisal | | | | | | | | | | | | | | | | | | | | | | | | | | | | | | | | | 0 |
| Pledge | | | | | | | | | | | | | | | | | | | | | | | | | | | | | | | | | 1 |
| Signing of Loan Agreement | | | | | | | | | | | | | | | | | | | | | | | | | | | | | | | | | 1 |
| Selection of Consultants (by OCBS Selection) | | | | | | | | | | | | | | | | | | | | | | | | | | | | | | | | | Month |
| Preparation of RFP & Short-list, and Approval by SCAPC | | | | | | | | | | | | | | | | | | | | | | | | | | | | | | | | | 2 |
| JICA Concurrence for RFP & Short-list | | | | | | | | | | | | | | | | | | | | | | | | | | | | | | | | | 1 |
| Issuance of RFP to Short-listed Consultants | | | | | | | | | | | | | | | | | | | | | | | | | | | | | | | | | 1 |
| Proposal Submission by Consultants | | | | | | | | | | | | | | | | | | | | | | | | | | | | | | | | | 2 |
| Evaluation of Technical proposals, Approval by SCAPC | | | | | | | | | | | | | | | | | | | | | | | | | | | | | | | | | 3 |
| JICA Concurrence for Evaluation of Technical Proposals | | | | | | | | | | | | | | | | | | | | | | | | | | | | | | | | | 1 |
| Opening Financial Proposals, Evaluation, Approval by SCAPC | | | | | | | | | | | | | | | | | | | | | | | | | | | | | | | | | 1 |
| JICA Concurrence for Evaluation of Proposals | | | | | | | | | | | | | | | | | | | | | | | | | | | | | | | | | 1 |
| Contract Negotiation, Approval by SCAPC, Approval by Cabinet | | | | | | | | | | | | | | | | | | | | | | | | | | | | | | | | | 2 |
| Signing of Contract | | | | | | | | | | | | | | | | | | | | | | | | | | | | | | | | | 1 |
| JICA Concurrence for Signed Contract | | | | | | | | | | | | | | | | | | | | | | | | | | | | | | | | | 1 |
| | | | | | | | | | | | | | | | | | | | | | | | | | | | | | | | | | 0 |
| Engineering and Bidding Period | | | | | | | | | | | | | | | | | | | | | | | | | | | | | | | | | Month |
| Detailed Design | | | | | | | | | | | | | | | | | | | | | | | | | | | | | | | | | 10 |
| Confirmation of DD by NWSDB, TEC, SCAPC | | | | | | | | | | | | | | | | | | | | | | | | | | | | | | | | | 2 |
| Preparation of PQ Documents, and Approval by SCAPC | | | | | | | | | | | | | | | | | | | | | | | | | | | | | | | | | 3 |
| JICA Concurrence for PQ Documents (above JPY 1,000 mil) | | | | | | | | | | | | | | | | | | | | | | | | | | | | | | | | | 1 |
| Issuance of PQ Documents | | | | | | | | | | | | | | | | | | | | | | | | | | | | | | | | | 1 |
| PQ Submission by Contractors | | | | | | | | | | | | | | | | | | | | | | | | | | | | | | | | | 1 |
| Evaluation of PQ, Approval by SCAPC | | | | | | | | | | | | | | | | | | | | | | | | | | | | | | | | | 2 |
| JICA Concurrence for PQ Results | | | | | | | | | | | | | | | | | | | | | | | | | | | | | | | | | 1 |
| Preparation of Tender Documents, and Approval by SCAPC | | | | | | | | | | | | | | | | | | | | | | | | | | | | | | | | | 3 |
| Tender Period | | | | | | | | | | | | | | | | | | | | | | | | | | | | | | | | | 3 |
| Tender Evaluation, and Approval by SCAPC | | | | | | | | | | | | | | | | | | | | | | | | | | | | | | | | | 2 |
| JICA Concurrence for Tender Evaluation | | | | | | | | | | | | | | | | | | | | | | | | | | | | | | | | | 1 |
| Approval by Cabinet | | | | | | | | | | | | | | | | | | | | | | | | | | | | | | | | | 1 |
| Signing of Contract | | | | | | | | | | | | | | | | | | | | | | | | | | | | | | | | | 1 |
| JICA Concurrence for Signed Contract | | | | | | | | | | | | | | | | | | | | | | | | | | | | | | | | | 1 |
| | | | | | | | | | | | | | | | | | | | | | | | | | | | | | | | | | |
| Non-Eligible | | | | | | | | | | | | | | | | | | | | | | | | | | | | | | | | | Month |
| Land Acquisition Cost | | | | | | | | | | | | | | | | | | | | | | | | | | | | | | | | | 56 |
| Installation of Distribution Sub System, Service Connections | | | | | | | | | | | | | | | | | | | | | | | | | | | | | | | | | 27 |
| Eligible | | | | | | | | | | | | | | | | | | | | | | | | | | | | | | | | | Month |
| 1. Intake, WTP, Elevated Tanks and Grand Sumps | | | | | | | | | | | | | | | | | | | | | | | | | | | | | | | | | 30 |
| 2. Transmission and Distribution Main | | | | | | | | | | | | | | | | | | | | | | | | | | | | | | | | | 33 |
| 3. Distribution Sub System | | | | | | | | | | | | | | | | | | | | | | | | | | | | | | | | | 27 |
| 4. O&M Equipment | | | | | | | | | | | | | | | | | | | | | | | | | | | | | | | | | 27 |
| | | | | | | | | | | | | | | | | | | | | | | | | | | | | | | | | | |
| Other Activities | | | | | | | | | | | | | | | | | | | | | | | | | | | | | | | | | Month |
| Training | | | | | | | | | | | | | | | | | | | | | | | | | | | | | | | | | 3 |
| Public Awareness Campaign | | | | | | | | | | | | | | | | | | | | | | | | | | | | | | | | | 4 |

Figure 8.1 Implementation Schedule

8.2 Contract Package

Construction packaging for the Project is one of the most important factors for the smooth implementation of all the components.

Construction works of water treatment plant will need several kinds of experience and expertise such as civil, structural, mechanical, electrical and instrumentation works. Coordination management among all these types of works will be a critical component. The time invested for

such coordination management will affect the timely completion of the project. Mechanical and electrical works will be implemented after the most of the structures have been completed. Careful arrangement with civil and architectural works will be required for the installation of mechanical and electrical equipment.

From the aspect of construction supervision and management, a project management consultant will be required to substantially review the contractors' work, organize progress meetings, scheduling, factory inspection, issue accomplishment certification, quality control, and preparation of documents for payment.

Under the JICA ODA loan procedures, the contract package shall be concurred by JICA for each stage of the prequalification evaluation, tender evaluation, and contract. In principle, under the JICA ODA loan procedure, tendering shall be done as International Competitive Bidding (ICB).

Proposed contract packages, total eight packages for the JICA ODA loan for the Project, which are shown in **Table 8.2**. The construction periods of packages are assumed and summarised as follows, considering the size of the project and work volume and workability.

Table 8.2 Proposed Contract Packages for Mahakanadarawa Project

| Package | Components | Cost (million Yen) | Period (month) | Procurement |
|-----------|---|-----------------------|-------------------|-------------|
| Package 1 | Intake, WTP, Ground Sumps and Elevated Tanks | 1,712 | 30 | ICB |
| Package 2 | Transmission/Distribution Mains | 1,263 | 33 | ICB |
| Package 3 | Distribution Sub-System | 534 | 27 | LCB |
| Package 4 | O&M Goods | 68 | 12 | LCB |
| Package 5 | Installation of Distribution Sub-System and House Connections | 56 | 27 | - |

Table 8.3 Proposed Contract Packages for Wahalkada Project

| Package | Components | Cost (million Yen) | Period (month) | Procurement |
|-----------|---|-----------------------|-------------------|-------------|
| Package 1 | Intake, WTP, Ground Sumps and Elevated Tanks | 2,543 | 37 | ICB |
| Package 2 | Transmission/Distribution Mains | 2,534 | 40 | ICB |
| Package 3 | Distribution Sub-System | 604 | 34 | LCB |
| Package 4 | O&M Goods | 72 | 19 | LCB |
| Package 5 | Installation of Distribution Sub-System and House Connections | 69 | 34 | - |

ICB (International Competitive Bidding) packages are selected with consideration of level of required technology/engineering, sizes of the packages etc. which the local contractors have

limited experiences in the contents of the works, and less technical and financial capacities. In this aspect, Package 1 consists of all civil, architectural, mechanical and electrical works in Intake Station, Water Treatment Plant, Ground Sumps and Elevated Tanks. The package requires higher technology/engineering for complicated structures and good coordination between different types of works. Package 2 needs experiences of long HDPE pipeline installations. HDPE with large diameter such as 450mm is still new for Sri Lankan Contractors and total length of over 250km.

However the rest of the packages are procured by LCB (Local Competitive Bidding) for the local contractors to provide business opportunities. Especially Package 3 consists of 1) 3-1: PVC 100-200mm supply and installation, 2) 3-2: PVC 50-75mm supply 3) 3-3: PVC 50-75mm installation etc. Pipe length of the Distribution Sub-System, currently proposed is tentative and will be determined by the detailed design.

Installation of PVC 50mm is categorised into Non-Eligible portion which Sri Lanka side will implement. NWSDB and CBO have many experiences through ADB funded project in this project area using community manpower to install small size of pipelines with NWSDB's piping materials and advices/supervision. This practice in the area will accelerate development of the distribution sub-systems.

8.3 Procurement Method

The selection of the consultant will need to be conducted by NWSDB in accordance with the JICA Guidelines and Government Procurement Guidelines – 2006 of Sri Lanka. The selection process of the consultant will have to be initiated as soon as possible, after the commitment for the finance is made by the Japanese side. Preparation of tender documents and detailed design will be carried out by the consultant to be selected and employed by NWSDB.

Conditions applied in the tender documents to select the contractor will also have to meet the requirements in the JICA Guidelines and Government Procurement Guidelines – 2006 of Sri Lanka. JICA normally requires that the procurement of goods and services will be obtained through ICB. Construction will, therefore, be carried out by the contractor/s awarded the contract through the ICB procurement method.

There are two major methods of construction contract based on the design conditions.

(1) Construction as designed

Contractors are issued for the detailed drawings to construct the facilities designed by the Employer and/or consultants. Construction will follow the detailed dimensions and specifications which are stipulated in the tender documents. Liability of the contractor will be limited to quality of the construction work as long as the facilities are built as designed. Preparation of design drawings will take a longer time compared with the design-build method. However, selection of the contractor is smooth and easy due to the evaluation mainly focus on the financial proposals among pre-qualified bidders strictly selected by technical and financial aspects of capacity, reliability, experiences etc.

(2) Design-build concept

Tender documents and drawings stipulate the minimum requirements for construction. Contractors will have flexibility in construction details. However, they are subject to approval by the Employer and/or consultants. As the structural design is normally carried out by the Contractor, time for the preparation of the tender document by the Employer and/or consultants will be shortened. The Contractor should be liable his own design. Preparation of the tender drawings in full details by the Employer and/or consultants will take longer time while introduction of the “design-build (turn-key) concept” will shorten the time for the design stage. However, with the advantages of the design-build (turn-key) concept, there are several issues need to be considered in the design-build concept. These issues are important for mitigation of the unnecessary time wastage during the construction period to be spent for review and revision of the design submitted by the Contractor.

From the above consideration and JICA’s experiences, “Construction as designed” will be applied in this Project.

The construction materials for civil works such as concrete, RC pile, sand, gravel, brick, reinforcement bar, sheet pile can be procured in Sri Lanka by the Contractor as per specifications in tender document. Pipe material such as HDPE is imported from suitable countries through ICB. Construction machinery such as excavator, pile driver, dump truck and bulldozer except a pipe jacking machine can be leased in Sri Lanka. Major mechanical equipment such as pumps, chemical dosing equipment and valves can be imported from suitable countries. Electrical equipment such as control panels, transformer and generator can be imported from suitable countries. While minor items such as cables can be procured in Sri Lanka if the specifications are fulfilled.

As described in the previous section, major packages, Packages 1/2/3/5/6/7 shall apply the ICB procurement method, while simple and small distribution pipe-laying packages 4/8 shall apply

the NCB procurement method.

8.4 Consulting Services (TOR)

NWSDB shall procure consultant services for detailed design of Anuradhapura North Integrated Water Supply Project and consultant shall consist of both international and national experts, sub-professionals and supporting staff.

Two JICA Loan Packages will be applied for this Project. The first is for consulting services consisting of the detailed design of both Mahakanadarawa and Wahalkada Water Supply Systems and construction supervision of Mahakanadarawa Water Supply System. The other is for consulting service covering only the construction supervision of Wahalkada Water Supply System.

The consulting services consist of detailed engineering design of the water intake, raw water transmission pipe line, water treatment plants at Mahakanadarawa and Wahalkada, transmission pumping facilities and transmission/distribution pipelines, ground reservoirs, elevated tanks, distribution sub-system for Mahakanadarawa and Wahalkada Systems, including all other related works, such as water pipe bridges and road restoration. The detail design will include preparation of detail technical specification and tender document for the works

NWSDB also shall procure construction supervision services for the management of the Project and the consultant shall consist of both international and national experts, sub-professionals and supporting staff.

There are several issues to be considered in the design stage from both technical and economical points of view as described below:

1) Participation of national consultants

Participation of national consultants is necessary for technology transfer from the international consultants. National consultants will also be able to contribute in making economical designs since they are familiar with local practices for construction works and locally available materials and equipment in Sri Lanka.

2) Approval of detailed design

During the design stage, engineering consultants appointed for the Project should be required to submit sufficient details to the Employer for their design prior to the preparation of the final design and specifications.

3) Process design

Process design will have to be determined considering not only technical aspects of operation but also cost-effective aspects. The treatment method, each treatment unit performance, detailed alignment etc. will have to be determined considering the reliability of the process, total costs for pipelines, structures and equipment as well as operation and maintenance costs.

4) Specifications

Specifications are to be developed by the design consultants to make contractors develop adequate confidence in preparing; costs for construction, equipment and O&M; ease of O&M; availability of services etc. in the design stage to select the best fit the conditions of the Project. Any equipment and machinery as well as material required for construction that is available and best fit condition.

CHAPTER 9 Environmental and Social Consideration

9.1 Natural Conditions

(1) Natural Conditions in the Study Area

The project area is a suburban and rural area, which is located in the northern part of Anuradhapura District. The climate is classified into the dry zone. The main industry is the agriculture for rice as a main crop. The land covered by forest and shrub is the largest in area. Compared with the heavy rain area, the species of fauna and flora are less and the biodiversity is poor due to less rare species. Some of project sites are located in the forest but they are the secondary forest and special attention is not required for the environmental protection.

(2) Protected Area

[Sanctuary]

The protection of a sanctuary is provided in “Fauna and Flora Protection Ordinance” and is controlled by the Department of Wildlife Conservation. The level of protection of a sanctuary is not so severe among the protection areas and a minor development action can be done with a permission of the authority although being required the implementation of EIA/IEE.

Around Mahakanadarawa Wewa, one of the proposed water sources in the project is designated as a sanctuary. The boundaries of a sanctuary is defined as within 400 yards (366 m) from the Full Supply Level of the reservoir or a center line of the bund wherever there is a bund as an artificial structure. While, the Central Environmental Authority (CEA) designated the buffer zone within 100 m from the boundary as a most susceptible area to an environmental impact. Since in the initial plan of the project, water was planned to be taken from the reservoir directly, the project was classified into Category B due to the fear of an impact on the protection area. However, thereafter, the plan of direct water intake was cancelled and instead changed so as to take water from an irrigation canal of the reservoir and the site for a water treatment plant was fixed outside a sanctuary. Therefore, an environmental impact was significantly reduced.

[Environmentally Sensitive Area]

The prescribed projects which are requested to implement EIA/IEE are defined and listed in the Gazette no 772/22 of 24th June, 1993 and 859/14 of 23rd February 1995. Only large-scale development projects that are likely to have significant impacts on the environment are listed as prescribed projects. There are two categories, although they are not applicable to the project.

1) By type and the magnitude

In case of Water Supply Project, the conditions are;

- All ground water extraction projects of capacity exceeding 1/2 million cubic meters

per day.

- Construction of water treatment plants of capacity exceeding 1/2 million cubic meters
- 2) By location (e.g. if projects are located wholly or partially within environmentally sensitive areas such as forest and wildlife reserves, stream or lake reservation, archaeological reserve, declared erodible areas etc.

On the other hand, from the view point of the susceptibility of an environmental impact, the following points were expected to be problematic.

- Within 100 meters from the boundaries of or within any area declared as a Sanctuary under the Fauna and Flora Protection Ordinance
- Within 100 meters from the high flood level contour of or within a public lake as defined in the Crown Lands Ordinance.

In the project, the water source is the reservoir but both an intake works and water treatment plant are more than 100 m downstream of the reservoir for both cases and the prescribed project is not applicable to.

[Forest]

There is no forest reserve land in the proposed sites. But if the land is designated as the forest, the permission for land use alteration is required from the Department of Forestry. NWSDB has received the permission for those of the construction sites that is included in the forest from the Department of Forestry

[Archeological Impact]

All the projects are required the assessment of an archeological impact. NWSDB has the permission of project implementation at the stage of pre-feasibility study. For the sites changed thereafter, NWSDB has submitted an additional application and got the permission for almost sites except for three locations which have been still waiting for the permission.

[Necessity of IEE/EIA]

In the initial plan, the direct water intake from the reservoir was supposed, but due to the instruction from the Irrigation Department, a water intake from the irrigation canal downstream of the reservoir was decided and any development action will not be done within the sanctuary or environmentally sensitive area. Therefore, although the environmental consideration will be required subsequently, it is not necessary to conduct the IEE/EIA. The environmental recommendation has been already received from the CEA, it is required to meet the conditions described therein. On the other hand, NWSDB has an obligation to get the environmental protection license three months before the commencement of facility operation.

9.2 Social Consideration

(1) Minority and Indigenous People

There are indigenous people called ‘**Veddas**’ in Sri Lanka, but there are none living in the study area. The ethnic composition in the study area is 91% Sinhalese, 1% Tamil and 8% Muslim. In Anuradhapura, the ratio of Sinhalese is higher than the national average at more than 90%.

(2) Socio-economic Conditions

The largest land use of the study area is covered by forest, followed by scrub. Cultivated land is mainly paddy fields. 70% of the people are engaged in the agriculture. The area has two rainy seasons, namely the months of October to December which is the main cultivation season and the period of March to April with scattered rains. Double cropping is possible if the rainfall is enough. The irrigation agriculture has been done from the ancient times in the study area with many tanks. Although the people have been trying to make use of limited water resource as much as possible, but the annual harvest heavily relies on the available water amount. Therefore, the desiring level of the people for water is very high. According the annual report of the Central Bank for the year of 2012, the poverty household in Anuradhapura District is 4.6% which is higher than the national average of 7.0%.

9.3 Human Resettlement and Land Acquisition

(1) Human Resettlement

Although the proposed sites for water treatment plants are the government land but there are the illegal occupants. For the Wahalkada site, the measures to shift the so as to avoid the human resettlement is taken. However, for the Mahakanadarawa site, since the available land limited for the facility layout, the human resettlement of one occupant is finally required. Therefore, the preliminary human resettlement programme was prepared. In Sri Lanka, there is the National Involuntary Resettlement Policy (NIRP) which has no significant gap with the JICA’s guidelines including the compensation in accordance with the reacquisition price. The guideline has already established for the contents to be included in the RAP which meets the JICA requirements. NWSDB has already started the explanation to the residents on the project and resettlement. The household is the family of two, Sinhalese or the majority people in Sri Lanka.

(2) Land Acquisition

Most of the project sites (30 acres) are the government land and NWSDB can use them through the payment of a lease fee, while 2. 2 acres of them is the private land which requires the acquisition. For all sites, the procedures to transfer the right for land use have been already commenced and

waited for the progress of public process among the agencies concerned which will take usually six months.

9.4 Scoping

The results of scoping are shown in **Table 9.1**.

Table 9.1 Scoping Result

| | Item | Impact | Description |
|---|-----------------------------------|--------|---|
| Pollution control (Construction stage) | Air | B (-) | Vehicles for construction generate exhaust gas and dust. |
| | Water quality | B (-) | There is possibility that turbid water will be generated by the construction work. |
| | Waste | B (-) | The construction work will generate surplus soil and waste. |
| | Noise and vibration | B (-) | Heavy equipment and trucks for construction will increase noise and vibration. |
| | Subsidence | D (0) | Groundwater level lowering work is not used. |
| Pollution control (operation stage) | Air | B (-) | There is possibility of spill from chlorine storage installation or chlorine dosing facility. |
| | Water quality | B (-) | Wastewater generated by the plant can contaminate the environment. Water quality of tank will not be changed because the facilities is located downstream, and amount of water use is not changed significantly. |
| | Waste | B (-) | Sludge by the treatment process could contaminate the environment. |
| | Noise and vibration | B (-) | The operation of facility generates noise and vibration. |
| | Subsidence | D (0) | There is no possibility the plant will cause the subsidence because of no use of groundwater. |
| | Protected area | B (-) | The project site is not inside the protected area, but in the vicinity. |
| | Ecosystem (construction stage) | B (-) | Trees inside and around the site will be cut and it decreases the habitat of living things. Heavy equipment and vehicles generates noise and vibration, and this could worsen the living environment of living things. |
| | Ecosystem (Operation stage) | B (-) | There is no groundwater extraction and the water use amount is not changed much, so groundwater recharge is not affected significantly. The permanent discharge from the tank is only irrigation canal so the natural condition of river is not considerable. On the other hand, if the water will be taken from the canal for drinking water treatment, it results to secure the base flow discharge. |

| | Item | Impact | Description |
|--------------------|------------------------|--------|---|
| Social environment | Resettlement | B (-) | A few families are required to move. |
| | Living and livelihood | B (-) | Acquisition of cultivation land is suspected. (Decision of site is required) In case, the farmers benefit will be decreased. It is a project to convert the use of water from irrigation to drinking. The users of irrigation water (farmer) will decrease the benefit. Water tariff will increase when CBO receive water from NWSDB. |
| | Heritage | C | Department of archeology issued the letter of clearance. Newly added sites require additional Clearance. |
| | Landscape | D (0) | The project will not develop any large-scale structure which can change the local landscape. |
| | Ethnic group | D (0) | In the Project site, there are no indigenous people. The main ethnic group is Sinhalese. |
| | Labor environment | C | Labor environment will be secured under the relevant regulations. |
| Others | Effect by construction | B (-) | Estimation of migration of labor power is necessary. Traffic jam will be avoided. |
| | Monitoring | B (-) | Monitoring plan should be established. |

* Evaluation A (- - - or - -): medium scale or large scale effect is expected

B(-) : effect is low

C : effect is unclear

D(0): no effect or improving direction

9.5 Mitigation Measures

The adverse impacts and its mitigation measures are listed in **Table 9.2**. The column of Impact shows the evaluation of potential impact after taking mitigation measures.

Table 9.2 List of Adverse Impacts and Its Mitigation Measures

Pre construction stage

| Impact | Object | Mitigation measures | Impact | In charge or implemented by | Supervising |
|---------------------|---|---|--------|-----------------------------|------------------|
| Noise and vibration | Pump, generator and other noise generation facility | <ul style="list-style-type: none"> Low noise/vibration pump and generator are specified in tender document. Building is designed with the consideration to decrease noise and vibration to meet the requirement. Location of these facilities is examined. | Minor | NWSDB HO | PMU (CEA) |
| Waste | Construction waste and Domestic waste | <ul style="list-style-type: none"> Waste management plan is prepared under discussion with CEA and DS. Temporally dumping area is | Minor | NWSDB RSC | PMU DS CEA |

| | | | | | |
|-------------------|--|---|-------|--------------|-----------------------------|
| | | secured. | | | |
| Ecological impact | Clearing land | <ul style="list-style-type: none"> Clearing land and cutting tree are planned under the discussion with Forest Dept and/or CEA. | Minor | NWSDB RSC | PMU Forest Dept CEA |
| | Rare species | <ul style="list-style-type: none"> Making a plan of transplant and recovery of habitat | Minor | NWSDB RSC | PMU Wildlife dept CEA |
| Resettlement | Resettlement | <ul style="list-style-type: none"> Progress of resettlement and its fairness are monitored. | Minor | NWSDB RSC | PMU DS |
| Social impact | Stakeholder meeting | <ul style="list-style-type: none"> Discussion and making agreement about construction schedule, procedure, and impact | Minor | NWSDB RSC | PMU PCC |
| | Public relation activities for local residents | <ul style="list-style-type: none"> Explanation for local residents and to develop understanding about construction work schedule, expected impacts, mitigation measures etc. | Minor | NWSDB RSC | PMU DS |

NWSDB RSC : National Water Supply and Drainage Board, Regional Support Centre

PMU: Project Management Unit

PCC: Project Coordination Committee

DS: Divisional Secretariat

Additional GM for water supply

Construction stage

| Impact | | Mitigation measures | Impact | In charge or implemented by | Supervising |
|---------------|-------------------------|--|--------|-----------------------------|-------------|
| Air pollution | Exhaust gas | <ul style="list-style-type: none"> To ensure the use of vehicles and machineries officially registered, and properly maintained. | Minor | Contractor | PMU |
| | Dust | <ul style="list-style-type: none"> To cover the earth or dusty materials To sprinkle water to prevent the dust raising. | Minor | Contractor | PMU |
| | Leakage of chlorine gas | <ul style="list-style-type: none"> Guidance of proper installation Safety training to laborer | Minor | Contractor | PMU |
| Noise | Vehicles and machinery | <ul style="list-style-type: none"> To ensure the use of vehicles and machineries officially registered, and properly maintained. Unnecessary idling is not allowed. Route of transportation is examined to prevent noise or other effect on vicinity. | Minor | Contractor | PMU |
| | Construction work | <ul style="list-style-type: none"> To avoid doing the work generating noise and vibration at nighttime. Sound insulation wall will be used if necessary. | Minor | Contractor | PMU |
| Water quality | Water source | <ul style="list-style-type: none"> Making water resource protection plan with the commitment of relevant authority | Minor | PMU | PD |
| | Discharge water | <ul style="list-style-type: none"> Clean water such as rain water is separately collected to prevent from mixing with muddy materials | Minor | Contractor | PMU |

| Impact | | Mitigation measures | Impact | In charge or implemented by | Supervising |
|------------------------|-------------------------------------|--|--------|-----------------------------|-----------------------------|
| | | <ul style="list-style-type: none"> Turbid water generated by earthwork is introduced to the sedimentation basin and turbid material will be settled. If necessary further treatment (use of coagulant) is done. | | | |
| | Domestic effluent | <ul style="list-style-type: none"> Effluent is treated by the soak pit. | Minor | Contractor | PMU |
| | Oil and grease | <ul style="list-style-type: none"> Oil and grease are kept separately in the container. Oil absorbent is prepared. | Minor | Contractor | PMU |
| Waste | Construction waste | <ul style="list-style-type: none"> The waste reduction plan and dumping procedure will be proposed at the tender document and implemented. The temporally dumping yard for construction waste is secured. Waste is segregated in order to recycling purpose. Recyclable material is transferred to the recycling manufacturer. Waste which is not recyclable is disposed to follow the fixed rule of relevant DS. | Minor | Contractor | PMU |
| | Domestic waste generated by laborer | <ul style="list-style-type: none"> Domestic waste is placed at the temporally dumping yard, and transferred to the officially operated disposal field | Minor | Contractor | PMU |
| Ecological environment | Violation to ecosystem | <ul style="list-style-type: none"> Training and awareness program for laborer is planned and done. Scheduled patrol of the site | Minor | Contractor | PMU |
| | Trees and plant | <ul style="list-style-type: none"> Clearing land is minimized and the large tree is remained as far as possible, or transplanted. | Minor | Contractor | PMU |
| | Rare species | <ul style="list-style-type: none"> If the special species will be found out at the site, report to NWSDB and receive the guidance of CEA or wildlife dept. | Minor | Contractor | PMU CEA Wildlife dept |
| Archaeological impact | Excavating antiquity | <ul style="list-style-type: none"> If the antiquity will be excavated at the site, report to NWSDB and receive the guidance of Archaeological dept. | Minor | Contractor | PMU Archaeological dept. |
| Social impact | Social conflict caused by laborer | <ul style="list-style-type: none"> Training and awareness program for laborer are planned and done. Security guard is appointed. | Minor | Contractor | PMU |
| | Inconvenience of livelihood | <ul style="list-style-type: none"> Pipe laying work on the road is planned carefully to prevent inconvenience as much as possible. Refraining from working during | Minor | Contractor | PMU |

| Impact | | Mitigation measures | Impact | In charge or implemented by | Supervising |
|-------------------|---------------------|--|--------|-----------------------------|-------------|
| | | <ul style="list-style-type: none"> peak hours to prevent road traffic blocks Public notice prior to construction | | | |
| Working condition | Occupational safety | <ul style="list-style-type: none"> Training and awareness program for laborer is planned and done. Safety tools are provided to laborer by Contractor. | Minor | Contractor | PMU |

Operation stage

| Impact | | Mitigation measures | Impact | In charge or implemented by | Supervising |
|-------------------|--------------------------------------|--|--------|-----------------------------|-------------|
| Air pollution | Leakage of chlorine gas | <ul style="list-style-type: none"> Gas monitor is working always at proper condition Safety training to laborer | Minor | NWSDB RSC | NWSDB HO |
| Noise | Noise generation facility (pump etc) | <ul style="list-style-type: none"> To ensure the proper operation and maintenance | Minor | NWSDB RSC | NWSDB HO |
| Water quality | Discharge water | <ul style="list-style-type: none"> Under drain water from sludge drying bed should be managed to meet the standards. | Minor | NWSDB RSC | NWSDB HO |
| | Domestic effluent | <ul style="list-style-type: none"> Effluent is treated by the soak pit. | Minor | NWSDB RSC | NWSDB HO |
| | Oil and grease | <ul style="list-style-type: none"> Oil and grease are kept separately in the container | Minor | NWSDB RSC | NWSDB HO |
| Waste | Domestic waste | <ul style="list-style-type: none"> Domestic waste is placed at the temporally collection place, and transferred to the officially operated disposal field | Minor | NWSDB RSC | NWSDB HO |
| | Sludge | <ul style="list-style-type: none"> Sludge is dried up at the drying bed to reduce its quantity Dried sludge is dumped by the contract with the approval of land owner. | Minor | NWSDB RSC | NWSDB HO |
| Working condition | Safety and health | <ul style="list-style-type: none"> Safety and emergency tool is always ready. Safety training is provided on schedule. Newly hired employee shall have safety training. | Minor | NWSDB RSC | NWSDB HO |

9.6 Environmental Check List

The evaluation with the JICA checklist is shown in **Table 9.3**.

Table 9.3 Environmental Checklist

| Category | Environmental Item | Main Check Items | Yes: Y No: N | Confirmation of Environmental Considerations (Reasons, Mitigation Measures) |
|---------------------------|---|--|--|--|
| 1 Permits and Explanation | (1) EIA and Environmental Permits | (a) Have EIA reports been already prepared in official process? (b) Have EIA reports been approved by authorities of the host country's government? (c) Have EIA reports been unconditionally approved? If conditions are imposed on the approval of EIA reports, are the conditions satisfied? (d) In addition to the above approvals, have other required environmental permits been obtained from the appropriate regulatory authorities of the host country's government? | (a) N/A (b) N/A (c) N/A (d) Y | (a) (b) (c) Under currently proposed project condition, EIA is not required. On the other hand, IEE level research was done by the Project. (d) Obtained clearances are as follows; • Clearance of Archeology dept • Clearance of Irrigation dept • Clearance of Forest dept • Clearance of CEA |
| | (2) Explanation to the Local Stakeholders | (a) Have contents of the project and the potential impacts been adequately explained to the Local stakeholders based on appropriate procedures, including information disclosure? Is understanding obtained from the Local stakeholders? (b) Have the comment from the stakeholders (such as local residents) been reflected to the project design? | (a) Y (b) Y | (a) NWSDB carried out the explanation session on 7th August. After election (8th September), NWSDB held the stakeholder meeting-23th September.(For Wahalkada) (b) The water intake procedure is changed due to the comment of the Irrigation Dept. The water intake quantity is will be decided with the agreement of stakeholders in case of unexpected drought. |
| | (3) Examination of Alternatives | (a) Have alternative plans of the project been examined with social and environmental considerations? | (a) Y | (a) Water intake procedure, location of facilities, course of pipe laying, treatment procedure were examined and the relative low impact plan was selected.. |

| Category | Environmental Item | Main Check Items | Yes: Y No: N | Confirmation of Environmental Considerations (Reasons, Mitigation Measures) |
|---------------------|--------------------|---|---------------------------|---|
| 2 Pollution Control | (1) Air Quality | <p>(a) Is there a possibility that chlorine from chlorine storage facilities and chlorine injection facilities will cause air pollution? Are any mitigating measures taken?</p> <p>(b) Do chlorine concentrations within the working environments comply with the country's occupational health and safety standards?</p> | <p>(a) N</p> <p>(b) N</p> | <p>(a) The chlorine gas neutralization system is provided. The gas leak detector will be installed which is able to start the neutralization system automatically so that the possibility of chlorine gas leakage is very low.</p> <p>(b) Sri Lankan Occupational Health Standards for chlorine is not existing. The facility will be designed to satisfy the American standards. Operation of exhaust fan achieves the standard requirement.</p> |

Occupational Safety and Health Guideline for Chlorine

| | Pollutant | Averaging Time* | Maximum Permissible Level | | Method of measurement |
|---|--|-----------------|---------------------------|-------|--|
| | | | ppm | ppm | |
| 1 | Particulate Matter - Aerodynamic diameter less than 10 µm in air (PM ₁₀) | Annual | 50 | R | In-volume sampling and Gravimetric or Beta Attenuation |
| | | 24 hrs. | 100 | R | |
| 2 | Particulate Matter - Aerodynamic diameter less than 2.5 µm in air (PM _{2.5}) | Annual | 25 | R | In-volume sampling and Gravimetric or Beta Attenuation |
| | | 24 hrs. | 50 | R | |
| 3 | Nitrogen Dioxide (NO ₂) | 24 hrs. | 100 | 0.05 | Colorimetric using saltzman Method or equivalent Gas phase chemiluminescence |
| | | 8 hrs. | 100 | 0.05 | |
| | | 1 hr. | 200 | 0.125 | |
| | | 15 min. | 200 | 0.05 | |
| 4 | Sulfur Dioxide (SO ₂) | 24 hrs. | 50 | 0.05 | Passive filter Method or equivalent Filter Fluorimetry |
| | | 8 hrs. | 100 | 0.05 | |
| 5 | Ozone (O ₃) | 1 hr. | 200 | 0.1 | Spectrophotometric Method or equivalent Ultraviolet Spectrophotometry |
| | | 8 hrs. | 10,000 | 9 | |
| 6 | Carbon Monoxide (CO) | 1 hr. | 30,000 | 26 | Spectrophotometry |
| | | Any time | 50,000 | 50 | |

| Category | Environmental Item | Main Check Items | Yes: Y No: N | Confirmation of Environmental Considerations (Reasons, Mitigation Measures) | | | | | | | | | | | | | | | | | | | | | | | | | | | | | | | | | | | | | | | | | | | | | | | | | | | | | | | | | | | | | | | | | | | | | | | | | | | | | | | | | | | | | | | | | | | | | | | | | | | | | | | | | | | | | | | | | | | | | | | | | | | | | | | | | | | | | | | | | | | | | | | | | | | | | | | | | | | | | | | | |
|-------------------|--|--|---|---|-----|-----------|------|-------|-----------------------|---|------------------------|-----------|----|----|---|---|---------------|----|----|---|---------------------------|---|-----------|-----------|---|---|-----------|----|----|---|--------------------------|---------|----|--|---|-----------------|-----------|----|----|---|--|-----------|-----|-----|---|------------------------------|-----------|-----|-----|---|-------|--|---|---|----|-----------------------------|-----------|---|---|----|--------------------------------|-----------|-----|-----|----|----------------------------|-----------|----|----|----|-----------------|-----------|-----|-----|----|-------------------------|-----------|---|---|----|-----------------|-----------|---|---|----|-----------------|-----------|-----|-----|----|-----------------|-----------|-----|-----|----|-----------------|-----------|-----|-----|----|-------------------------|-----------|-----|-----|----|-------------------------------|-----------|---|---|----|----------------|-----------|---|---|----|--------------|-----------|-----|-----|----|-------------------|-----------|--------|--------|----|-----------------|-----------|---|---|----|----------------|-----------|------|------|----|------------------|-----------|---|---|----|--------------|-----------|-------|-------|----|------------|-----------|---|---|----|-------------|-----------|----|----|----|---------------|-----------------|-----------------|-----------------|----|--|--|--------------------------------------|--------------------------------------|
| (2) Water Quality | | (a) Do pollutants, such as SS, BOD, COD contained in effluents discharged by the facility operations comply with the country's effluent standards? | (a) Y | <p>(a) Turbid water generated during construction works is collected to the sedimentation pond for solid-liquid separation. Domestic wastewater of employees is treated by a septic tank and supernatant is discharged into a soak pit for infiltration into the ground. The backwash drain generated during by the usual plant operation is collected in to drain ponds for solid-liquid separation. So the treated effluent will meet the Sri Lankan discharge water quality standard.</p> <table border="1" data-bbox="582 302 1165 884"> <thead> <tr> <th>No.</th> <th>Parameter</th> <th>Unit</th> <th>Limit</th> <th>Tolerance Limit value</th> </tr> </thead> <tbody> <tr> <td>1</td> <td>Total suspended solids</td> <td>mg/l, max</td> <td>50</td> <td>50</td> </tr> <tr> <td>2</td> <td>Particle size of the total suspended solids</td> <td>µm, less than</td> <td>50</td> <td>50</td> </tr> <tr> <td>3</td> <td>pH at ambient temperature</td> <td>-</td> <td>6.0 - 8.5</td> <td>6.0 - 8.5</td> </tr> <tr> <td>4</td> <td>Biochemical oxygen demand (BOD₅)</td> <td>mg/l, max</td> <td>30</td> <td>30</td> </tr> <tr> <td>5</td> <td>Temperature of discharge</td> <td>°C, max</td> <td>40</td> <td>Shall not exceed 40°C in any section of the stream within 15 m down stream from the effluent outlet.</td> </tr> <tr> <td>6</td> <td>Oils and grease</td> <td>mg/l, max</td> <td>10</td> <td>10</td> </tr> <tr> <td>7</td> <td>Phenolic compounds (as C₆H₅OH)</td> <td>mg/l, max</td> <td>250</td> <td>250</td> </tr> <tr> <td>8</td> <td>Chemical oxygen demand (COD)</td> <td>mg/l, max</td> <td>250</td> <td>250</td> </tr> <tr> <td>9</td> <td>Color</td> <td>Wavelength range: 435 nm (Yellow range) 525 nm (Red range) 620 nm (Blue range)</td> <td>Maximum spectral absorption coefficient</td> <td>7 m⁻¹ 5 m⁻¹ 5 m⁻¹</td> </tr> <tr> <td>10</td> <td>Dissolved phosphates (as P)</td> <td>mg/l, max</td> <td>5</td> <td>5</td> </tr> <tr> <td>11</td> <td>Total Kjeldahl nitrogen (as N)</td> <td>mg/l, max</td> <td>150</td> <td>150</td> </tr> <tr> <td>12</td> <td>Ammoniacal nitrogen (as N)</td> <td>mg/l, max</td> <td>50</td> <td>50</td> </tr> <tr> <td>13</td> <td>Cyanide (as CN)</td> <td>mg/l, max</td> <td>0.2</td> <td>0.2</td> </tr> <tr> <td>14</td> <td>Total residual chlorine</td> <td>mg/l, max</td> <td>1</td> <td>1</td> </tr> <tr> <td>15</td> <td>Fluoride (as F)</td> <td>mg/l, max</td> <td>2</td> <td>2</td> </tr> <tr> <td>16</td> <td>Sulphide (as S)</td> <td>mg/l, max</td> <td>0.2</td> <td>0.2</td> </tr> <tr> <td>17</td> <td>Arsenic (as As)</td> <td>mg/l, max</td> <td>0.1</td> <td>0.1</td> </tr> <tr> <td>18</td> <td>Cadmium (as Cd)</td> <td>mg/l, max</td> <td>0.5</td> <td>0.5</td> </tr> <tr> <td>19</td> <td>Chromium, total (as Cr)</td> <td>mg/l, max</td> <td>0.1</td> <td>0.1</td> </tr> <tr> <td>20</td> <td>Chromium, Hexavalent (as Cr6)</td> <td>mg/l, max</td> <td>3</td> <td>3</td> </tr> <tr> <td>21</td> <td>Copper (as Cu)</td> <td>mg/l, max</td> <td>3</td> <td>3</td> </tr> <tr> <td>22</td> <td>Lead (as Pb)</td> <td>mg/l, max</td> <td>0.1</td> <td>0.1</td> </tr> <tr> <td>23</td> <td>Manganese (as Mn)</td> <td>mg/l, max</td> <td>0.0005</td> <td>0.0005</td> </tr> <tr> <td>24</td> <td>Mercury (as Hg)</td> <td>mg/l, max</td> <td>3</td> <td>3</td> </tr> <tr> <td>25</td> <td>Nickel (as Ni)</td> <td>mg/l, max</td> <td>0.05</td> <td>0.05</td> </tr> <tr> <td>26</td> <td>Selenium (as Se)</td> <td>mg/l, max</td> <td>2</td> <td>2</td> </tr> <tr> <td>27</td> <td>Zinc (as Zn)</td> <td>mg/l, max</td> <td>0.005</td> <td>0.005</td> </tr> <tr> <td>28</td> <td>Pesticides</td> <td>mg/l, max</td> <td>5</td> <td>5</td> </tr> <tr> <td>29</td> <td>Surfactants</td> <td>mg/l, max</td> <td>40</td> <td>40</td> </tr> <tr> <td>30</td> <td>Radioisotopes</td> <td>MPN/100 ml, max</td> <td>10⁶</td> <td>10⁶</td> </tr> <tr> <td>31</td> <td>Radio Active Material : (a) Alpha emitters (b) beta emitters</td> <td>micro curieml, max micro curieml, max</td> <td>10⁻⁶ 10⁻⁷</td> <td>10⁻⁶ 10⁻⁷</td> </tr> </tbody> </table> | No. | Parameter | Unit | Limit | Tolerance Limit value | 1 | Total suspended solids | mg/l, max | 50 | 50 | 2 | Particle size of the total suspended solids | µm, less than | 50 | 50 | 3 | pH at ambient temperature | - | 6.0 - 8.5 | 6.0 - 8.5 | 4 | Biochemical oxygen demand (BOD ₅) | mg/l, max | 30 | 30 | 5 | Temperature of discharge | °C, max | 40 | Shall not exceed 40°C in any section of the stream within 15 m down stream from the effluent outlet. | 6 | Oils and grease | mg/l, max | 10 | 10 | 7 | Phenolic compounds (as C ₆ H ₅ OH) | mg/l, max | 250 | 250 | 8 | Chemical oxygen demand (COD) | mg/l, max | 250 | 250 | 9 | Color | Wavelength range: 435 nm (Yellow range) 525 nm (Red range) 620 nm (Blue range) | Maximum spectral absorption coefficient | 7 m ⁻¹ 5 m ⁻¹ 5 m ⁻¹ | 10 | Dissolved phosphates (as P) | mg/l, max | 5 | 5 | 11 | Total Kjeldahl nitrogen (as N) | mg/l, max | 150 | 150 | 12 | Ammoniacal nitrogen (as N) | mg/l, max | 50 | 50 | 13 | Cyanide (as CN) | mg/l, max | 0.2 | 0.2 | 14 | Total residual chlorine | mg/l, max | 1 | 1 | 15 | Fluoride (as F) | mg/l, max | 2 | 2 | 16 | Sulphide (as S) | mg/l, max | 0.2 | 0.2 | 17 | Arsenic (as As) | mg/l, max | 0.1 | 0.1 | 18 | Cadmium (as Cd) | mg/l, max | 0.5 | 0.5 | 19 | Chromium, total (as Cr) | mg/l, max | 0.1 | 0.1 | 20 | Chromium, Hexavalent (as Cr6) | mg/l, max | 3 | 3 | 21 | Copper (as Cu) | mg/l, max | 3 | 3 | 22 | Lead (as Pb) | mg/l, max | 0.1 | 0.1 | 23 | Manganese (as Mn) | mg/l, max | 0.0005 | 0.0005 | 24 | Mercury (as Hg) | mg/l, max | 3 | 3 | 25 | Nickel (as Ni) | mg/l, max | 0.05 | 0.05 | 26 | Selenium (as Se) | mg/l, max | 2 | 2 | 27 | Zinc (as Zn) | mg/l, max | 0.005 | 0.005 | 28 | Pesticides | mg/l, max | 5 | 5 | 29 | Surfactants | mg/l, max | 40 | 40 | 30 | Radioisotopes | MPN/100 ml, max | 10 ⁶ | 10 ⁶ | 31 | Radio Active Material : (a) Alpha emitters (b) beta emitters | micro curieml, max micro curieml, max | 10 ⁻⁶ 10 ⁻⁷ | 10 ⁻⁶ 10 ⁻⁷ |
| No. | Parameter | Unit | Limit | Tolerance Limit value | | | | | | | | | | | | | | | | | | | | | | | | | | | | | | | | | | | | | | | | | | | | | | | | | | | | | | | | | | | | | | | | | | | | | | | | | | | | | | | | | | | | | | | | | | | | | | | | | | | | | | | | | | | | | | | | | | | | | | | | | | | | | | | | | | | | | | | | | | | | | | | | | | | | | | | | | | | | | | | | |
| 1 | Total suspended solids | mg/l, max | 50 | 50 | | | | | | | | | | | | | | | | | | | | | | | | | | | | | | | | | | | | | | | | | | | | | | | | | | | | | | | | | | | | | | | | | | | | | | | | | | | | | | | | | | | | | | | | | | | | | | | | | | | | | | | | | | | | | | | | | | | | | | | | | | | | | | | | | | | | | | | | | | | | | | | | | | | | | | | | | | | | | | | | |
| 2 | Particle size of the total suspended solids | µm, less than | 50 | 50 | | | | | | | | | | | | | | | | | | | | | | | | | | | | | | | | | | | | | | | | | | | | | | | | | | | | | | | | | | | | | | | | | | | | | | | | | | | | | | | | | | | | | | | | | | | | | | | | | | | | | | | | | | | | | | | | | | | | | | | | | | | | | | | | | | | | | | | | | | | | | | | | | | | | | | | | | | | | | | | | |
| 3 | pH at ambient temperature | - | 6.0 - 8.5 | 6.0 - 8.5 | | | | | | | | | | | | | | | | | | | | | | | | | | | | | | | | | | | | | | | | | | | | | | | | | | | | | | | | | | | | | | | | | | | | | | | | | | | | | | | | | | | | | | | | | | | | | | | | | | | | | | | | | | | | | | | | | | | | | | | | | | | | | | | | | | | | | | | | | | | | | | | | | | | | | | | | | | | | | | | | |
| 4 | Biochemical oxygen demand (BOD ₅) | mg/l, max | 30 | 30 | | | | | | | | | | | | | | | | | | | | | | | | | | | | | | | | | | | | | | | | | | | | | | | | | | | | | | | | | | | | | | | | | | | | | | | | | | | | | | | | | | | | | | | | | | | | | | | | | | | | | | | | | | | | | | | | | | | | | | | | | | | | | | | | | | | | | | | | | | | | | | | | | | | | | | | | | | | | | | | | |
| 5 | Temperature of discharge | °C, max | 40 | Shall not exceed 40°C in any section of the stream within 15 m down stream from the effluent outlet. | | | | | | | | | | | | | | | | | | | | | | | | | | | | | | | | | | | | | | | | | | | | | | | | | | | | | | | | | | | | | | | | | | | | | | | | | | | | | | | | | | | | | | | | | | | | | | | | | | | | | | | | | | | | | | | | | | | | | | | | | | | | | | | | | | | | | | | | | | | | | | | | | | | | | | | | | | | | | | | | |
| 6 | Oils and grease | mg/l, max | 10 | 10 | | | | | | | | | | | | | | | | | | | | | | | | | | | | | | | | | | | | | | | | | | | | | | | | | | | | | | | | | | | | | | | | | | | | | | | | | | | | | | | | | | | | | | | | | | | | | | | | | | | | | | | | | | | | | | | | | | | | | | | | | | | | | | | | | | | | | | | | | | | | | | | | | | | | | | | | | | | | | | | | |
| 7 | Phenolic compounds (as C ₆ H ₅ OH) | mg/l, max | 250 | 250 | | | | | | | | | | | | | | | | | | | | | | | | | | | | | | | | | | | | | | | | | | | | | | | | | | | | | | | | | | | | | | | | | | | | | | | | | | | | | | | | | | | | | | | | | | | | | | | | | | | | | | | | | | | | | | | | | | | | | | | | | | | | | | | | | | | | | | | | | | | | | | | | | | | | | | | | | | | | | | | | |
| 8 | Chemical oxygen demand (COD) | mg/l, max | 250 | 250 | | | | | | | | | | | | | | | | | | | | | | | | | | | | | | | | | | | | | | | | | | | | | | | | | | | | | | | | | | | | | | | | | | | | | | | | | | | | | | | | | | | | | | | | | | | | | | | | | | | | | | | | | | | | | | | | | | | | | | | | | | | | | | | | | | | | | | | | | | | | | | | | | | | | | | | | | | | | | | | | |
| 9 | Color | Wavelength range: 435 nm (Yellow range) 525 nm (Red range) 620 nm (Blue range) | Maximum spectral absorption coefficient | 7 m ⁻¹ 5 m ⁻¹ 5 m ⁻¹ | | | | | | | | | | | | | | | | | | | | | | | | | | | | | | | | | | | | | | | | | | | | | | | | | | | | | | | | | | | | | | | | | | | | | | | | | | | | | | | | | | | | | | | | | | | | | | | | | | | | | | | | | | | | | | | | | | | | | | | | | | | | | | | | | | | | | | | | | | | | | | | | | | | | | | | | | | | | | | | | |
| 10 | Dissolved phosphates (as P) | mg/l, max | 5 | 5 | | | | | | | | | | | | | | | | | | | | | | | | | | | | | | | | | | | | | | | | | | | | | | | | | | | | | | | | | | | | | | | | | | | | | | | | | | | | | | | | | | | | | | | | | | | | | | | | | | | | | | | | | | | | | | | | | | | | | | | | | | | | | | | | | | | | | | | | | | | | | | | | | | | | | | | | | | | | | | | | |
| 11 | Total Kjeldahl nitrogen (as N) | mg/l, max | 150 | 150 | | | | | | | | | | | | | | | | | | | | | | | | | | | | | | | | | | | | | | | | | | | | | | | | | | | | | | | | | | | | | | | | | | | | | | | | | | | | | | | | | | | | | | | | | | | | | | | | | | | | | | | | | | | | | | | | | | | | | | | | | | | | | | | | | | | | | | | | | | | | | | | | | | | | | | | | | | | | | | | | |
| 12 | Ammoniacal nitrogen (as N) | mg/l, max | 50 | 50 | | | | | | | | | | | | | | | | | | | | | | | | | | | | | | | | | | | | | | | | | | | | | | | | | | | | | | | | | | | | | | | | | | | | | | | | | | | | | | | | | | | | | | | | | | | | | | | | | | | | | | | | | | | | | | | | | | | | | | | | | | | | | | | | | | | | | | | | | | | | | | | | | | | | | | | | | | | | | | | | |
| 13 | Cyanide (as CN) | mg/l, max | 0.2 | 0.2 | | | | | | | | | | | | | | | | | | | | | | | | | | | | | | | | | | | | | | | | | | | | | | | | | | | | | | | | | | | | | | | | | | | | | | | | | | | | | | | | | | | | | | | | | | | | | | | | | | | | | | | | | | | | | | | | | | | | | | | | | | | | | | | | | | | | | | | | | | | | | | | | | | | | | | | | | | | | | | | | |
| 14 | Total residual chlorine | mg/l, max | 1 | 1 | | | | | | | | | | | | | | | | | | | | | | | | | | | | | | | | | | | | | | | | | | | | | | | | | | | | | | | | | | | | | | | | | | | | | | | | | | | | | | | | | | | | | | | | | | | | | | | | | | | | | | | | | | | | | | | | | | | | | | | | | | | | | | | | | | | | | | | | | | | | | | | | | | | | | | | | | | | | | | | | |
| 15 | Fluoride (as F) | mg/l, max | 2 | 2 | | | | | | | | | | | | | | | | | | | | | | | | | | | | | | | | | | | | | | | | | | | | | | | | | | | | | | | | | | | | | | | | | | | | | | | | | | | | | | | | | | | | | | | | | | | | | | | | | | | | | | | | | | | | | | | | | | | | | | | | | | | | | | | | | | | | | | | | | | | | | | | | | | | | | | | | | | | | | | | | |
| 16 | Sulphide (as S) | mg/l, max | 0.2 | 0.2 | | | | | | | | | | | | | | | | | | | | | | | | | | | | | | | | | | | | | | | | | | | | | | | | | | | | | | | | | | | | | | | | | | | | | | | | | | | | | | | | | | | | | | | | | | | | | | | | | | | | | | | | | | | | | | | | | | | | | | | | | | | | | | | | | | | | | | | | | | | | | | | | | | | | | | | | | | | | | | | | |
| 17 | Arsenic (as As) | mg/l, max | 0.1 | 0.1 | | | | | | | | | | | | | | | | | | | | | | | | | | | | | | | | | | | | | | | | | | | | | | | | | | | | | | | | | | | | | | | | | | | | | | | | | | | | | | | | | | | | | | | | | | | | | | | | | | | | | | | | | | | | | | | | | | | | | | | | | | | | | | | | | | | | | | | | | | | | | | | | | | | | | | | | | | | | | | | | |
| 18 | Cadmium (as Cd) | mg/l, max | 0.5 | 0.5 | | | | | | | | | | | | | | | | | | | | | | | | | | | | | | | | | | | | | | | | | | | | | | | | | | | | | | | | | | | | | | | | | | | | | | | | | | | | | | | | | | | | | | | | | | | | | | | | | | | | | | | | | | | | | | | | | | | | | | | | | | | | | | | | | | | | | | | | | | | | | | | | | | | | | | | | | | | | | | | | |
| 19 | Chromium, total (as Cr) | mg/l, max | 0.1 | 0.1 | | | | | | | | | | | | | | | | | | | | | | | | | | | | | | | | | | | | | | | | | | | | | | | | | | | | | | | | | | | | | | | | | | | | | | | | | | | | | | | | | | | | | | | | | | | | | | | | | | | | | | | | | | | | | | | | | | | | | | | | | | | | | | | | | | | | | | | | | | | | | | | | | | | | | | | | | | | | | | | | |
| 20 | Chromium, Hexavalent (as Cr6) | mg/l, max | 3 | 3 | | | | | | | | | | | | | | | | | | | | | | | | | | | | | | | | | | | | | | | | | | | | | | | | | | | | | | | | | | | | | | | | | | | | | | | | | | | | | | | | | | | | | | | | | | | | | | | | | | | | | | | | | | | | | | | | | | | | | | | | | | | | | | | | | | | | | | | | | | | | | | | | | | | | | | | | | | | | | | | | |
| 21 | Copper (as Cu) | mg/l, max | 3 | 3 | | | | | | | | | | | | | | | | | | | | | | | | | | | | | | | | | | | | | | | | | | | | | | | | | | | | | | | | | | | | | | | | | | | | | | | | | | | | | | | | | | | | | | | | | | | | | | | | | | | | | | | | | | | | | | | | | | | | | | | | | | | | | | | | | | | | | | | | | | | | | | | | | | | | | | | | | | | | | | | | |
| 22 | Lead (as Pb) | mg/l, max | 0.1 | 0.1 | | | | | | | | | | | | | | | | | | | | | | | | | | | | | | | | | | | | | | | | | | | | | | | | | | | | | | | | | | | | | | | | | | | | | | | | | | | | | | | | | | | | | | | | | | | | | | | | | | | | | | | | | | | | | | | | | | | | | | | | | | | | | | | | | | | | | | | | | | | | | | | | | | | | | | | | | | | | | | | | |
| 23 | Manganese (as Mn) | mg/l, max | 0.0005 | 0.0005 | | | | | | | | | | | | | | | | | | | | | | | | | | | | | | | | | | | | | | | | | | | | | | | | | | | | | | | | | | | | | | | | | | | | | | | | | | | | | | | | | | | | | | | | | | | | | | | | | | | | | | | | | | | | | | | | | | | | | | | | | | | | | | | | | | | | | | | | | | | | | | | | | | | | | | | | | | | | | | | | |
| 24 | Mercury (as Hg) | mg/l, max | 3 | 3 | | | | | | | | | | | | | | | | | | | | | | | | | | | | | | | | | | | | | | | | | | | | | | | | | | | | | | | | | | | | | | | | | | | | | | | | | | | | | | | | | | | | | | | | | | | | | | | | | | | | | | | | | | | | | | | | | | | | | | | | | | | | | | | | | | | | | | | | | | | | | | | | | | | | | | | | | | | | | | | | |
| 25 | Nickel (as Ni) | mg/l, max | 0.05 | 0.05 | | | | | | | | | | | | | | | | | | | | | | | | | | | | | | | | | | | | | | | | | | | | | | | | | | | | | | | | | | | | | | | | | | | | | | | | | | | | | | | | | | | | | | | | | | | | | | | | | | | | | | | | | | | | | | | | | | | | | | | | | | | | | | | | | | | | | | | | | | | | | | | | | | | | | | | | | | | | | | | | |
| 26 | Selenium (as Se) | mg/l, max | 2 | 2 | | | | | | | | | | | | | | | | | | | | | | | | | | | | | | | | | | | | | | | | | | | | | | | | | | | | | | | | | | | | | | | | | | | | | | | | | | | | | | | | | | | | | | | | | | | | | | | | | | | | | | | | | | | | | | | | | | | | | | | | | | | | | | | | | | | | | | | | | | | | | | | | | | | | | | | | | | | | | | | | |
| 27 | Zinc (as Zn) | mg/l, max | 0.005 | 0.005 | | | | | | | | | | | | | | | | | | | | | | | | | | | | | | | | | | | | | | | | | | | | | | | | | | | | | | | | | | | | | | | | | | | | | | | | | | | | | | | | | | | | | | | | | | | | | | | | | | | | | | | | | | | | | | | | | | | | | | | | | | | | | | | | | | | | | | | | | | | | | | | | | | | | | | | | | | | | | | | | |
| 28 | Pesticides | mg/l, max | 5 | 5 | | | | | | | | | | | | | | | | | | | | | | | | | | | | | | | | | | | | | | | | | | | | | | | | | | | | | | | | | | | | | | | | | | | | | | | | | | | | | | | | | | | | | | | | | | | | | | | | | | | | | | | | | | | | | | | | | | | | | | | | | | | | | | | | | | | | | | | | | | | | | | | | | | | | | | | | | | | | | | | | |
| 29 | Surfactants | mg/l, max | 40 | 40 | | | | | | | | | | | | | | | | | | | | | | | | | | | | | | | | | | | | | | | | | | | | | | | | | | | | | | | | | | | | | | | | | | | | | | | | | | | | | | | | | | | | | | | | | | | | | | | | | | | | | | | | | | | | | | | | | | | | | | | | | | | | | | | | | | | | | | | | | | | | | | | | | | | | | | | | | | | | | | | | |
| 30 | Radioisotopes | MPN/100 ml, max | 10 ⁶ | 10 ⁶ | | | | | | | | | | | | | | | | | | | | | | | | | | | | | | | | | | | | | | | | | | | | | | | | | | | | | | | | | | | | | | | | | | | | | | | | | | | | | | | | | | | | | | | | | | | | | | | | | | | | | | | | | | | | | | | | | | | | | | | | | | | | | | | | | | | | | | | | | | | | | | | | | | | | | | | | | | | | | | | | |
| 31 | Radio Active Material : (a) Alpha emitters (b) beta emitters | micro curieml, max micro curieml, max | 10 ⁻⁶ 10 ⁻⁷ | 10 ⁻⁶ 10 ⁻⁷ | | | | | | | | | | | | | | | | | | | | | | | | | | | | | | | | | | | | | | | | | | | | | | | | | | | | | | | | | | | | | | | | | | | | | | | | | | | | | | | | | | | | | | | | | | | | | | | | | | | | | | | | | | | | | | | | | | | | | | | | | | | | | | | | | | | | | | | | | | | | | | | | | | | | | | | | | | | | | | | | |
| (3) Wastes | | (a) Are wastes, such as sludge generated by the facility operations properly treated and disposed in accordance with the country's regulations? | (a) Y | (a) The generated sludge is collected from chemical sedimentation basins and condensed by thickener. Condensed sludge is transferred to sludge lagoons to be dried by solar evaporation. The dried sludge is hauled to the solid waste dumping site for final disposal. | | | | | | | | | | | | | | | | | | | | | | | | | | | | | | | | | | | | | | | | | | | | | | | | | | | | | | | | | | | | | | | | | | | | | | | | | | | | | | | | | | | | | | | | | | | | | | | | | | | | | | | | | | | | | | | | | | | | | | | | | | | | | | | | | | | | | | | | | | | | | | | | | | | | | | | | | | | | | | | | |

| Category | Environmental Item | Main Check Items | Yes: Y No: N | Confirmation of Environmental Considerations (Reasons, Mitigation Measures) | | | | | | | | | | | | | | | | | | | | | | | | | | | | | | | | | | | | |
|--|-------------------------|---|-----------------|---|----------|--|----------|------------|----------|--|----|--|------------|--|--|----|------|----------|------------|------------------------|----|----|------------------------|----|----|----------------------|----|----|-------------------|----|----|------------------|----|----|-----------------|----|----|--|----|----|
| | (4) Noise and Vibration | (a) Do noise and vibrations generated from the facilities, such as pumping stations comply with the country's standards? | (a) Y | <p>(a) The main generating sources of noise and vibration are generator and pump. The low-noise type and low- vibration type equipment is selected for reduction of noise and vibration and installed in the building so as to meet the Sri Lankan standards. The standards to be followed is shown below.</p> <div style="text-align: center;"> <p>Maximum permissible Noise Levels at Boundaries of the land in which the source of noise is located in various activities</p> <table border="1"> <thead> <tr> <th colspan="2">Land Use</th> <th>Day time</th> <th>Night time</th> </tr> </thead> <tbody> <tr> <td>Day time</td> <td></td> <td>75</td> <td></td> </tr> <tr> <td>Night time</td> <td></td> <td></td> <td>55</td> </tr> </tbody> </table> <p>Maximum permissible Noise Levels at Boundaries in Land Use T for industrial activities</p> <table border="1"> <thead> <tr> <th>Area</th> <th>Day time</th> <th>Night time</th> </tr> </thead> <tbody> <tr> <td>Rural Residential Area</td> <td>55</td> <td>45</td> </tr> <tr> <td>Urban Residential Area</td> <td>60</td> <td>50</td> </tr> <tr> <td>Noise Sensitive Area</td> <td>50</td> <td>45</td> </tr> <tr> <td>Mixed Residential</td> <td>63</td> <td>55</td> </tr> <tr> <td>Commercial Areas</td> <td>65</td> <td>55</td> </tr> <tr> <td>Industrial Area</td> <td>70</td> <td>60</td> </tr> <tr> <td>Japanese Environmental Standard A. (residential area)</td> <td>55</td> <td>45</td> </tr> </tbody> </table> </div> | Land Use | | Day time | Night time | Day time | | 75 | | Night time | | | 55 | Area | Day time | Night time | Rural Residential Area | 55 | 45 | Urban Residential Area | 60 | 50 | Noise Sensitive Area | 50 | 45 | Mixed Residential | 63 | 55 | Commercial Areas | 65 | 55 | Industrial Area | 70 | 60 | Japanese Environmental Standard A. (residential area) | 55 | 45 |
| Land Use | | Day time | Night time | | | | | | | | | | | | | | | | | | | | | | | | | | | | | | | | | | | | | |
| Day time | | 75 | | | | | | | | | | | | | | | | | | | | | | | | | | | | | | | | | | | | | | |
| Night time | | | 55 | | | | | | | | | | | | | | | | | | | | | | | | | | | | | | | | | | | | | |
| Area | Day time | Night time | | | | | | | | | | | | | | | | | | | | | | | | | | | | | | | | | | | | | | |
| Rural Residential Area | 55 | 45 | | | | | | | | | | | | | | | | | | | | | | | | | | | | | | | | | | | | | | |
| Urban Residential Area | 60 | 50 | | | | | | | | | | | | | | | | | | | | | | | | | | | | | | | | | | | | | | |
| Noise Sensitive Area | 50 | 45 | | | | | | | | | | | | | | | | | | | | | | | | | | | | | | | | | | | | | | |
| Mixed Residential | 63 | 55 | | | | | | | | | | | | | | | | | | | | | | | | | | | | | | | | | | | | | | |
| Commercial Areas | 65 | 55 | | | | | | | | | | | | | | | | | | | | | | | | | | | | | | | | | | | | | | |
| Industrial Area | 70 | 60 | | | | | | | | | | | | | | | | | | | | | | | | | | | | | | | | | | | | | | |
| Japanese Environmental Standard A. (residential area) | 55 | 45 | | | | | | | | | | | | | | | | | | | | | | | | | | | | | | | | | | | | | | |
| | (5) Subsidence | (a) In the case of extraction of a large volume of groundwater, is there a possibility that the extraction of groundwater will cause subsidence? | (a) N | (a) The project does not extract groundwater. | | | | | | | | | | | | | | | | | | | | | | | | | | | | | | | | | | | | |
| 3 Natural Environment | (1) Protected Areas | (a) Is the project site or discharge area located in protected areas designated by the country's laws or international treaties and conventions? Is there a possibility that the project will affect the protected areas? | (a) N | (a) The project area is located outside of protected area. However, the environmental impact should be minimized. | | | | | | | | | | | | | | | | | | | | | | | | | | | | | | | | | | | | |

| Category | Environmental Item | Main Check Items | Yes: Y No: N | Confirmation of Environmental Considerations (Reasons, Mitigation Measures) |
|----------|--------------------|---|---|---|
| | (2) Ecosystem | <p>(a) Does the project site encompass primeval forests, tropical rain forests, ecologically valuable habitats (e.g., coral reefs, mangroves, or tidal flats)?</p> <p>(b) Does the project site or discharge area encompass the protected habitats of endangered species designated by the country's laws or international treaties and conventions?</p> <p>(c) If significant ecological impacts are anticipated, are adequate protection measures taken to reduce the impacts on the ecosystem?</p> <p>(d) Is there a possibility that the amount of water used (e.g., surface water, groundwater) by project will adversely affect aquatic environments, such as rivers? Are adequate measures taken to reduce the impacts on aquatic environments, such as aquatic organisms?</p> | <p>(a) N</p> <p>(b) N</p> <p>(c) N/A</p> <p>(d) N</p> | <p>(a) Some part of project area is located in the forest but the forest does not require special attention for conservation.</p> <p>(b) According to the report of ecological survey, a few number of endemic and endangered species were found. But these species are dominant in the wet area, and the protection of habitat in the project area is not so seriously required.</p> <p>(c) The significant ecological impact is not expected.</p> <p>(d) The project takes water from irrigation canal so the adverse effect to the aquatic environment is limited. Furthermore, the purpose of the use of the project, the water will let flow on a steady basis. it will improve the environment.</p> |
| | (3) Hydrology | <p>(a) Is there a possibility that the amount of water used (e.g., surface water, groundwater) by the project will adversely affect surface water and groundwater flows?</p> | <p>(a) N</p> | <p>(a) Currently, the water is used only the purpose of irrigation. The project will share a part of current water use, so the effect is negligible.</p> |

| Category | Environmental Item | Main Check Items | Yes: Y No: N | Confirmation of Environmental Considerations (Reasons, Mitigation Measures) |
|----------------------|---------------------------|--|---|---|
| 4 Social Environment | (1) Resettlement | <p>(a) Is involuntary resettlement caused by project implementation? If involuntary resettlement is caused, are efforts made to minimize the impacts caused by the resettlement?</p> <p>(b) Is adequate explanation on compensation and resettlement assistance given to affected people prior to resettlement?</p> <p>(c) Is the resettlement plan, including compensation with full replacement costs, restoration of livelihoods and living standards developed based on socioeconomic studies on resettlement?</p> <p>(d) Is the compensations going to be paid prior to the resettlement?</p> <p>(e) Is the compensation policies prepared in document?</p> <p>(f) Does the resettlement plan pay particular attention to vulnerable groups or people, including women, children, the elderly, people below the poverty line, ethnic minorities, and indigenous peoples?</p> <p>(g) Are agreements with the affected people obtained prior to resettlement?</p> <p>(h) Is the organizational framework established to properly implement resettlement? Are the capacity and budget secured to implement the plan?</p> <p>(i) Are any plans developed to monitor the impacts of resettlement?</p> <p>(j) Is the grievance redress mechanism established?</p> | <p>(a) Y</p> <p>(b) Y</p> <p>(c) Y</p> <p>(d) Y</p> <p>(e) Y</p> <p>(f) N/A</p> <p>(g) Y</p> <p>(h) Y</p> <p>(i) Y</p> <p>(j) Y</p> | <p>Confirmation of Environmental Considerations (Reasons, Mitigation Measures)</p> <p>(a) One illegal occupants house is located in the Mahakanadarawa WTP site. NWSDB is preparing RAP in accordance with the JICA guidelines and Sri Lanka 'National Involuntary Resettlement Policy'.</p> <p>(b) NWSDB and DSD explained the Project and necessity of change of the land use to the occupant. The occupant understood the necessity of the Project and agreed to leave the place.</p> <p>(c) Compensation with full replacement costs, restoration of livelihoods and living standards are secured.</p> <p>(d) Compensations will be paid prior to the physical resettlement.</p> <p>(e) Sri Lanka has 'National Involuntary Resettlement Policy' approved by Cabinet in 2001. And there is no big gap from JICA Guideline.</p> <p>(f) The occupants are married couple only and belong to ethnically major group. They will be supplied the new land near their relatives. They are not considered as people in vulnerable group.</p> <p>(g) NWSDB obtained the agreement letter from occupants.</p> <p>(h) NWSDB shall bare the cost for resettlement. The estimation is done by District evaluation officer. Divisional secretariat and NWSDB are responsible for taking care of the occupants.</p> <p>(i) Monitoring plan is written in the RAP.</p> <p>(j) DS is the first contact window of grievance. If the problem is not solved, DS will request the participation of NWSDB and find the solution.</p> |
| 4 Social Environment | (2) Living and Livelihood | <p>(a) Is there a possibility that the project will adversely affect the living conditions of inhabitants? Are adequate measures considered to reduce the impacts, if necessary?(b) Is there a possibility that the amount of water used (e.g., surface water, groundwater) by the project will adversely affect the existing water uses and water area uses?</p> | <p>(a) Y</p> <p>(b) N</p> | <p>(a) Currently, the farmers in the area feel that the water supply capacity is not sufficient, but the other parallel going project for integration of irrigation system will increase the water supply in the area and the total water demand will be secured.</p> <p>(b) The villagers living the surrounding of the tank use tank water for domestic use. But same reason described above can solve the potential problem.</p> |

| Category | Environmental Item | Main Check Items | Yes: Y No: N | Confirmation of Environmental Considerations (Reasons, Mitigation Measures) |
|----------|--|---|----------------------------------|--|
| | (3) Heritage | (a) Is there a possibility that the project will damage the local archaeological, historical, cultural, and religious heritage? Are adequate measures considered to protect these sites in accordance with the country's laws? | (a) N | (a) The project area is not located in archaeological reserves. However, the project will take care and make an action plan in the case of excavating antiquities. |
| | (4) Landscape | (a) Is there a possibility that the project will adversely affect the local landscape? Are necessary measures taken? | (a) N | (a) The size of all facilities are small and the effect on the landscape is ignorable. |
| | (5) Ethnic Minorities and Indigenous Peoples | (a) Are considerations given to reduce impacts on the culture and lifestyle of ethnic minorities and indigenous peoples? (b) Are all of the rights of ethnic minorities and indigenous peoples in relation to land and resources respected? | (a) N/A (b) N/A | There is no indigenous group in the project area. And any ethnic minorities are not affected by the project. |
| | (6) Working Conditions | (a) Is the project proponent not violating any laws and ordinances associated with the working conditions of the country which the project proponent should observe in the project? (b) Are tangible safety considerations in place for individuals involved in the project, such as the installation of safety equipment which prevents industrial accidents, and management of hazardous materials? (c) Are intangible measures being planned and implemented for individuals involved in the project, such as the establishment of a safety and health program, and safety training (including traffic safety and public health) for workers etc.? (d) Are appropriate measures taken to ensure that security guards involved in the project not to violate safety of other individuals involved, or local residents? | (a) N (b) Y (c) Y (d) Y | (a) NWSDB follows the Labor law, Factories Ordinance. (b) The contract condition is made under the 'Standard Bidding Document Procurement of Works' or 'Conditions of Contract'. And the Occupational safety and hazardous management will be secured. (c) It will be specified in a contract document, and implemented (d) It will be specified in a contract document, and implemented. |

| Category | Environmental Item | Main Check Items | Yes: Y No: N | Confirmation of Environmental Considerations (Reasons, Mitigation Measures) |
|----------|---------------------------------|---|--|--|
| 5 Others | (1) Impacts during Construction | <p>(a) Are adequate measures considered to reduce impacts during construction (e.g., noise, vibrations, turbid water, dust, exhaust gases, and wastes)?</p> <p>(b) If construction activities adversely affect the natural environment (ecosystem), are adequate measures considered to reduce impacts?</p> <p>(c) If construction activities adversely affect the social environment, are adequate measures considered to reduce impacts?</p> <p>(d) If the construction activities might cause traffic congestion, are adequate measures considered to reduce such impacts?</p> | <p>(a) Y (b) Y (c) Y (d) Y</p> | <p>The contractor has to obey the contract document and take appropriate measures to protect environment and social conditions.</p> <ul style="list-style-type: none"> • Noise and vibration is controlled by the proper use of well maintained vehicles and machineries. The night time work is avoided. In case, the use of special tools or material to reduce the noise and vibration such as sound barrier is used. • Turbid water is collected separately and treated by sedimentation basin. if necessary the coagulant will be used. • Waste will be managed by the contractor. It shall be segregated and recycled as much as possible. Temporally stock place is secured and the waste is treated with the consultation of DS. • Dust is controlled by watering and use of cover. • Emission of exhausted gases is manageable by use of registered vehicles and machinery with proper maintenance. <p>(b) The protection and mitigation measures are taken.</p> <p>(c) The people living in the project site is only one married couple. RAP is prepared for them for fair resettlement..</p> <p>(d) The construction activities are prevented to the inhabitant who is potentially affected for traffic congestion. Construction plan is descloised.</p> |

| Category | Environmental Item | Main Check Items | Yes: Y No: N | Confirmation of Environmental Considerations (Reasons, Mitigation Measures) | | | | | | | | | | | | | | | | | | | | | | | | | | | | | | | | | | | | | | | | | | | | | | | | | | | | | | | | | | | | | | | | | | | | | | | | | | | | | | |
|---|--|--|---|---|-------------|--|--|-----------------------------|---|--|--|--|---|--|--|--|---|--|--|--|---|--|--|--|----|------|-------|---|---|--|--|--|---|--|--|--|------------------------|----------------|---------------------|--|--------------|--|-----------------------------|-------------|-------------|-------------|-------------|--------------------|--|--|--|--|--|--|------------------------|--|--|--|--|--|--|--------------------------------------|--|--|--|--|--|--|-------------------------------------|--|--|--|--|--|--|---|--|--|--|--|--|--|
| | | | | <p>Monitoring plan of resettlement</p> <p>Preparation of resettlement site</p> <table border="1" data-bbox="343 353 443 884"> <thead> <tr> <th>NO</th> <th>Fieldwork Completion (date / not complete)</th> <th>Details of Site selection, development of candidate sites, discussion with PAPs, Development of the site, etc)</th> <th>Expected Date of Completion</th> </tr> </thead> <tbody> <tr><td>1</td><td></td><td></td><td></td></tr> <tr><td>2</td><td></td><td></td><td></td></tr> <tr><td>3</td><td></td><td></td><td></td></tr> <tr><td>4</td><td></td><td></td><td></td></tr> </tbody> </table> <p>Public Consultation</p> <table border="1" data-bbox="454 459 510 884"> <thead> <tr> <th>NO</th> <th>Date</th> <th>Place</th> <th>Content of the consultation (main concerns and answers)</th> </tr> </thead> <tbody> <tr><td>1</td><td></td><td></td><td></td></tr> <tr><td>2</td><td></td><td></td><td></td></tr> </tbody> </table> <p>Programs</p> <table border="1" data-bbox="534 257 686 884"> <thead> <tr> <th rowspan="2">Preparation of studies</th> <th rowspan="2">Review for USE</th> <th colspan="2">Review in Quarterly</th> <th colspan="2">Program in %</th> <th rowspan="2">Expected Date of Completion</th> </tr> <tr> <th>1st QUARTER</th> <th>2nd QUARTER</th> <th>1st QUARTER</th> <th>2nd QUARTER</th> </tr> </thead> <tbody> <tr><td>Preparation of PAP</td><td></td><td></td><td></td><td></td><td></td><td></td></tr> <tr><td>Preparation of PPA/LUE</td><td></td><td></td><td></td><td></td><td></td><td></td></tr> <tr><td>Preparation of Compensation Register</td><td></td><td></td><td></td><td></td><td></td><td></td></tr> <tr><td>Preparation of Land Allocation List</td><td></td><td></td><td></td><td></td><td></td><td></td></tr> <tr><td>Preparation of Relocation of Households</td><td></td><td></td><td></td><td></td><td></td><td></td></tr> </tbody> </table> | NO | Fieldwork Completion (date / not complete) | Details of Site selection, development of candidate sites, discussion with PAPs, Development of the site, etc) | Expected Date of Completion | 1 | | | | 2 | | | | 3 | | | | 4 | | | | NO | Date | Place | Content of the consultation (main concerns and answers) | 1 | | | | 2 | | | | Preparation of studies | Review for USE | Review in Quarterly | | Program in % | | Expected Date of Completion | 1st QUARTER | 2nd QUARTER | 1st QUARTER | 2nd QUARTER | Preparation of PAP | | | | | | | Preparation of PPA/LUE | | | | | | | Preparation of Compensation Register | | | | | | | Preparation of Land Allocation List | | | | | | | Preparation of Relocation of Households | | | | | | |
| NO | Fieldwork Completion (date / not complete) | Details of Site selection, development of candidate sites, discussion with PAPs, Development of the site, etc) | Expected Date of Completion | | | | | | | | | | | | | | | | | | | | | | | | | | | | | | | | | | | | | | | | | | | | | | | | | | | | | | | | | | | | | | | | | | | | | | | | | | | | | | | |
| 1 | | | | | | | | | | | | | | | | | | | | | | | | | | | | | | | | | | | | | | | | | | | | | | | | | | | | | | | | | | | | | | | | | | | | | | | | | | | | | | | | | | |
| 2 | | | | | | | | | | | | | | | | | | | | | | | | | | | | | | | | | | | | | | | | | | | | | | | | | | | | | | | | | | | | | | | | | | | | | | | | | | | | | | | | | | |
| 3 | | | | | | | | | | | | | | | | | | | | | | | | | | | | | | | | | | | | | | | | | | | | | | | | | | | | | | | | | | | | | | | | | | | | | | | | | | | | | | | | | | |
| 4 | | | | | | | | | | | | | | | | | | | | | | | | | | | | | | | | | | | | | | | | | | | | | | | | | | | | | | | | | | | | | | | | | | | | | | | | | | | | | | | | | | |
| NO | Date | Place | Content of the consultation (main concerns and answers) | | | | | | | | | | | | | | | | | | | | | | | | | | | | | | | | | | | | | | | | | | | | | | | | | | | | | | | | | | | | | | | | | | | | | | | | | | | | | | | |
| 1 | | | | | | | | | | | | | | | | | | | | | | | | | | | | | | | | | | | | | | | | | | | | | | | | | | | | | | | | | | | | | | | | | | | | | | | | | | | | | | | | | | |
| 2 | | | | | | | | | | | | | | | | | | | | | | | | | | | | | | | | | | | | | | | | | | | | | | | | | | | | | | | | | | | | | | | | | | | | | | | | | | | | | | | | | | |
| Preparation of studies | Review for USE | Review in Quarterly | | Program in % | | Expected Date of Completion | | | | | | | | | | | | | | | | | | | | | | | | | | | | | | | | | | | | | | | | | | | | | | | | | | | | | | | | | | | | | | | | | | | | | | | | | | | | |
| | | 1st QUARTER | 2nd QUARTER | 1st QUARTER | 2nd QUARTER | | | | | | | | | | | | | | | | | | | | | | | | | | | | | | | | | | | | | | | | | | | | | | | | | | | | | | | | | | | | | | | | | | | | | | | | | | | | | |
| Preparation of PAP | | | | | | | | | | | | | | | | | | | | | | | | | | | | | | | | | | | | | | | | | | | | | | | | | | | | | | | | | | | | | | | | | | | | | | | | | | | | | | | | | | |
| Preparation of PPA/LUE | | | | | | | | | | | | | | | | | | | | | | | | | | | | | | | | | | | | | | | | | | | | | | | | | | | | | | | | | | | | | | | | | | | | | | | | | | | | | | | | | | |
| Preparation of Compensation Register | | | | | | | | | | | | | | | | | | | | | | | | | | | | | | | | | | | | | | | | | | | | | | | | | | | | | | | | | | | | | | | | | | | | | | | | | | | | | | | | | | |
| Preparation of Land Allocation List | | | | | | | | | | | | | | | | | | | | | | | | | | | | | | | | | | | | | | | | | | | | | | | | | | | | | | | | | | | | | | | | | | | | | | | | | | | | | | | | | | |
| Preparation of Relocation of Households | | | | | | | | | | | | | | | | | | | | | | | | | | | | | | | | | | | | | | | | | | | | | | | | | | | | | | | | | | | | | | | | | | | | | | | | | | | | | | | | | | |
| 6 Note | Reference to Checklist of Other Sectors Note on Using Environmental Checklist | (a) Where necessary, pertinent items described in the Dam and River Projects checklist should also be checked. (a) If necessary, the impacts to transboundary or global issues should be confirmed (e.g., the project includes factors that may cause problems, such as transboundary waste treatment, acid rain, destruction of the ozone layer, or global warming). | (a) N/A (a) N/A | (a) The project does not develop the dam and canal. The project only use the existing facilities for irrigation. There is no item to conflict with the Dam and River Projects checklist. (a) There is no negative impact to transboundary or global issues because the project is small scale water supply scheme targeting the improvement of living standards. | | | | | | | | | | | | | | | | | | | | | | | | | | | | | | | | | | | | | | | | | | | | | | | | | | | | | | | | | | | | | | | | | | | | | | | | | | | | | | |

CHAPTER 10 FINANCIAL AND ECONOMIC ANALYSIS

10.1 General

This chapter of financial and economic analysis shows whether this water supply project is financially feasible and economically beneficial. The former financial feasibility is measured by the project financial internal rate of return (FIRR). The Government or NWSDB does not need to think about profit, but rather be assured of the soft loan interest rate. Therefore, the FIRR of this project should be more than the soft loan interest rate. This is the criterion for project feasibility. If the project FIRR does not satisfy this criterion or is too low, this does not necessarily mean that the project should not proceed. The next method is to use economic cost-benefit analysis. In this water supply project, the benefits are in the form of satisfaction expressed by willingness-to-pay (WTP) and health impacts (medical cost reduction). Instead of income in the FIRR calculation, these economic benefits are estimated and discounted annually. The cost is the same as the FIRR calculation. Thus, the economic internal rate of return (EIRR) can be calculated similarly to the FIRR. Past World Bank projects have pegged EIRR to be a minimum of 12%, but usually the EIRRs of water supply projects seem lower than the other project EIRRs. In addition to the statistical data, an *ad hoc* social and economic survey in the project site was conducted in order to define and estimate the project benefits. Therefore, the social and economic situation of the project site is summarized indicating the data on estimated benefits of the project and affordable tariffs, taking into account willingness-to-pay.

Next, the project finance with FIRR is analyzed. After that, the economic (cost-benefit) analysis with EIRR is made to examine the project viability. Lastly, sensitivity analyses are made on the financial and economic estimates to examine uncertainties and risks.

10.2 Social and Economic Conditions (Tariffs and Economic Situations) in Project Area

This section presents the existing tariffs of CBO and NWSDB after a summary of the general social and economic situation in the project area in Chapter 9.

After the project completion, new water supply users can be divided into two groups. One is a direct NWSDB water user group. The other is a CBO user group, which is supplied with NWSDB water through CBO systems. The direct NWSDB users will pay the charges based on the NWSDB tariffs. The CBO users at present are charged based on the tariffs of the CBOs and each CBO sets its tariff independently based on its financial situation. On the other hand, if this project is completed, the NWSDB will supply the CBOs with water. NWSDB has tariffs for supplying bulk water to rural water supply schemes maintained by the CBOs. Using the CBO's monthly consumption, charges of the NWSDB to CBOs can be calculated and charges per unit can be

obtained by dividing this by the monthly consumption. The CBO survey also questioned about the model charge for a supposed 18m³ monthly use based on the CBO tariffs and charges per unit can be obtained.

The water sales per unit (m³) of the CBOs range from 4.7 Rs./m³ to 44.5 Rs./m³ and the average of which is 19.6 Rs./m³. NWSDB's average overall charge in 2011 is 36.1 Rs./m³ in North Central Region. Obviously, the CBO's average charge is cheaper than NWSDB's, although there are a few CBOs whose charges are higher than NWSDB's.

The model charges per unit (assuming 18m³/month consumption) are cheaper than sales/m³ except in seven cases. If the tariffs of NWSDB for CBOs are applied to the current consumption of CBOs, the charges per unit (m³) will range from 19.3 to 24.6 of which the average is 21.0Rs./m³. Therefore, while some CBO's current charges per unit are more expensive than NWSDB's charges per unit, most CBOs' are actually cheaper than NWSDB's as the averages (19.6 and 21.0, respectively) show. However, in this calculation, the average non-revenue water rate of 20% is used in order to compare the user price. Specifically, consumption is multiplied by 1.25 (=1/0.8) to calculate the charge of NWSDB bulk water, but the NWSDB charge is divided by consumption without multiplication. The CBO survey included a question about the proposed (willing-to-pay) price for NWSDB's bulk water. The CBO answers ranged from 20 to 30Rs./ m³, but most answers were 25Rs./m³. Therefore, CBOs may be satisfied with the NWSDB's bulk tariffs from the viewpoint of the CBO purchase unit price because the NWSDB charge is divided by consumption (multiplied by 1.25).

If the project is implemented, the CBOs will connect to the NWSDB system and will have to pay the charges to NWSDB. This will increase the CBO expenditures. Among the present expenditures of CBOs that would remain or partially remain are personnel costs, chemical costs and maintenance costs. However, electricity costs will not be necessary.

Assuming that chemical and maintenance costs are half of the present expenditures, the cost-basis prices of the CBOs can be calculated by summing the water purchase unit price from NWSDB, personnel costs and half of the chemical and maintenance costs per unit. Some CBOs estimated cost prices are cheaper than the present CBO's charges per unit (five CBOs); however in most CBOs they are higher. The average shows an increase from 19.6 to 30.4Rs./m³, or an increase of approximately 55%. In addition, the tariffs of NWSDB were raised from October 1, 2012 and the usage charge was increased from 12 Rs./m³ to 18 Rs./m³, or a 50% increase, and monthly service charge was raised by 10%. Therefore, the estimated cost prices have risen within 50%. The discussion above is based on the NWSDB's old tariffs, but it is better because the NWSDB tariffs were old during the CBO survey. When the new tariffs are applied to the CBO, the average CBO bulk payment unit to NWSDB becomes 29.7 Rs./m³, or 1.39 times

increase. However, most users accept the charges if they are set relevantly according to the social economic survey.

10.3 Financial Analysis

10.3.1 Preconditions and Methods

The preconditions and methods of FIRR calculation are as follows.

- The calculation is based on the net or constant price because tariffs are controlled by the government and not easy to raise although inflation is occurring.
- The investment amount and the construction schedule are used as described in Chapter 7, “Project Cost,” and Chapter 8, “Project Implementation.” The investment costs include taxes, but they exclude interest payments during the construction period, because IRR treats only cash flow.
- Part of the invested assets such as buildings and plants has longer lives (depreciation periods) such as 50 or 60 years and the planning period is shorter so that the remaining residual values of these long life assets are input as minus investment at the end of the calculation period. However, shorter life assets such as machines and vehicles are not reinvested after their lifetimes such as seven or 10 years end within the planning period because they are usually used continuously and not reinvested.
- The income from operation is based on the tariffs, but specifically, the billed amount and water used in 2011 shown by the NWSDB statistics are used to calculate income per water volume (North Central Region domestic 25.0 Rs./ m³) and this unit is multiplied by the estimated demand water volume. However, the NWSDB tariffs were raised from October 1, 2012 and new income per water volume is not clear because there is no statistic data after the tariff increase. Assuming the income per water volume becomes 1.5 times. The North Central Region domestic 25.0 Rs./ m³ increases to 37.5 Rs./ m³ (=25 x 1.5). Therefore, this FIRR calculation uses 37.5 Rs./ m³ as income per water volume.
- The operations costs are based on the estimates described in 7.6 “Operation and Maintenance Cost,” Chapter 7, “Project Cost.”

10.3.2 FIRR Results

(1) Mahakanadarawa

The Mahakanadarawa water source area FIRR calculation result is -2.71% (Case 1: Phase 2 investment in 2024 is made). In Case 2, Phase 2 investment is not made and the water demand after 2025 is the same as that in 2024. In both cases, FIRRs are minus and so this project cannot be covered by the profits. The difference between the two cases is 0.12% and small. In order to make it positive, the tariffs should be raised 2.5 times of the present level. In addition, since this is

calculated in net (constant price), it is assumed that tariffs are almost always revised based on the inflation in gross (market price).

Since the tariffs need to be 2.5 times of the present level in order to make FIRR positive, sensitivity analyses are neither effective nor useful. Therefore, sensitivity analysis is omitted. However, NWSDB will bear only 20% of the investment costs in this project because this project area includes no municipalities. Instead of sensitivity analysis, FIRR of a case that investment cost decreases to 20% of the total investment is calculated. If the income per water volume increases 1.5 times (37.5 Rs./m³) because of the tariff raise, the FIRR becomes positive (0.42%). NWSDB may be able to pay interest and repay JICA if making efforts. However, this does not mean that the total project is covered by the profits. Of course, this 1.5 times increase of tariffs is also based on the additional inflation coverage.

(2) Wahalkada

The result of Wahalkada FIRR calculation is -2.88% in Case 1 and -2.80% in Case 2. The result is a little worse than those of Mahakanadarawa Cases because Wahalkada is a lower-density area and the investment is less efficient than Mahakanadarawa.

Similarly to the Mahakanadarawa case, a case in which NWSDB's burden is 20% of the investment is calculated and the FIRR becomes 1.5%, higher than the Mahakanadarawa case because of the more demand compared with the reduced investment.

10.4 Economic Analysis

10.4.1 Preconditions and Methods

The preconditions and methods of EIRR calculation are similar to those of FIRR above, but with some differences as follows.

- The investment costs exclude taxes and interest payments during the construction period. In addition, domestic currency part of the investment is converted to border price using a conversion factor. The conversion factor, 0.9, used in Sri Lanka will also be used in this analysis.
- Benefits are estimated instead of the operation income in FIRR, but it is necessary to explain the benefits in detail so that they are described separately below.

10.4.2 Benefits

Main benefits are derived from willingness-to-pay (WTP) amounts. The other benefits are reduction of medical and related costs caused by water borne diseases such as diarrhea, dysentery

and viral hepatitis.

The WTP amounts are set based on the new users (No Supply) group as lower amount of either actual payment per m³ or 4% income per m³ because No Supply group and CBO users can use safer water of NWSDB by the project. In addition, these benefits are calculated only for No Supply group and CBO user group. Although some existing NWSDB water users use well water, the benefits of NWSDB users are excluded in this benefit calculation because the benefits should be conservative..

Water borne diseases such as fluorosis, diarrhea, dysentery and viral hepatitis can be reduced as this project enables the residents to use clean and better quality water. Although some diseases such as diarrhea, dysentery and viral hepatitis are not only caused by water but also by bad foods and unsanitary conditions, the social economic survey separated the users into three groups, namely NWSDB, CBO and No Supply, so that the water borne disease rates in these groups can be compared.

10.4.3 EIRR Results

(1) Mahakanadarawa

In Case 1 (with Phase 2 investment), the EIRR of Mahakandarawa Case 1 (Unit: Mill. Rs.) is 6.91% and is better as compared with those of other water supply projects. In addition, if CKD benefits are included, the EIRR becomes 11.8%, a satisfactory figure.

In Case 2 (without the additional investment), the EIRR is 5.54%, less than that of Case 1. If CKD benefits are included, the EIRR becomes 10.4%.

In order to estimate sensitivity, the investment, operational costs and benefits are changed to plus 10% or minus 10%. The investment cost change affects the EIRR the most, but the difference is only -0.73% or +0.86%. The second most effective change is the operations cost and the difference is -0.06% or +0.07%. The benefit change difference is very small at -0.01% or +0.01%.

Table 10.1 EIRR of Mahakandarawa Case 1 (With Phase 2 Investment)

| Year | Investmt. | Operation costs | Cash Flow | | Benefits | | | | | | |
|-------------|-----------|-----------------|--------------|--------------|----------|-----|-----------|---------|-----------------|-----------|--|
| | | | Excl. CKD | Incl. CKD | WTP | CKD | Fluorosis | Diarhea | Viral Hepatitis | Dysentery | |
| 2013 | 72.3 | | -72 | -72 | | | | | | | |
| 2014 | 382.8 | | -383 | -383 | | | | | | | |
| 2015 | 842.0 | | -842 | -842 | | | | | | | |
| 2016 | 2,718.1 | | -3,718 | -2,718 | | | | | | | |
| 2017 | 2,826.9 | | -2,827 | -2,827 | | | | | | | |
| 2018 | 750.2 | 34 | -429 | -158 | 322 | 271 | 27 | 4 | 0.4 | 1.6 | |
| 2019 | 14.0 | 46 | 440 | 809 | 455 | 369 | 37 | 5 | 0.6 | 2.2 | |
| 2020 | | 48 | 480 | 857 | 481 | 377 | 38 | 5 | 0.6 | 2.3 | |
| 2021 | | 49 | 507 | 893 | 509 | 386 | 39 | 5 | 0.6 | 23.0 | |
| 2022 | | 51 | 534 | 928 | 536 | 395 | 40 | 5 | 0.6 | 2.4 | |
| 2023 | | 53 | 565 | 969 | 568 | 404 | 41 | 5 | 0.6 | 2.4 | |
| 2024 | 733.0 | 54 | -137 | 276 | 600 | 413 | 42 | 5 | 0.6 | 2.5 | |
| 2025 | | 66 | 628 | 1,052 | 642 | 424 | 43 | 5 | 0.7 | 2.5 | |
| 2026 | | 71 | 667 | 1,103 | 685 | 436 | 44 | 6 | 0.7 | 2.6 | |
| 2027 | | 76 | 714 | 1,182 | 732 | 468 | 48 | 6 | 0.7 | 2.8 | |
| 2028 | | 80 | 761 | 1,262 | 780 | 501 | 51 | 6 | 0.8 | 3.0 | |
| 2029 | | 85 | 811 | 1,342 | 832 | 530 | 54 | 7 | 0.8 | 3.2 | |
| 2030 | | 90 | 861 | 1,421 | 883 | 560 | 57 | 7 | 0.9 | 3.4 | |
| 2031 | | 95 | 915 | 1,505 | 937 | 591 | 60 | 8 | 0.9 | 3.6 | |
| 2032 | | 100 | 968 | 1,589 | 992 | 622 | 63 | 8 | 1.0 | 3.8 | |
| 2033 | | 104 | 1,024 | 1,674 | 1,050 | 649 | 66 | 8 | 1.0 | 3.9 | |
| 2034 | | 109 | 1,081 | 1,758 | 1,108 | 677 | 62 | 2 | 1.1 | 4.1 | |
| 2035 | | 109 | 1,081 | 1,758 | 1,108 | 677 | 69 | 9 | 1.1 | 4.1 | |
| 2036 | | 109 | 1,081 | 1,758 | 1,108 | 677 | 69 | 9 | 1.1 | 4.1 | |
| 2037 | | 109 | 1,081 | 1,758 | 1,108 | 677 | 69 | 9 | 1.1 | 4.1 | |
| 2038 | | 109 | 1,081 | 1,758 | 1,108 | 677 | 69 | 9 | 1.1 | 4.1 | |
| 2039 | -3,432.0 | 109 | 4,513 | 5,190 | 1,108 | 677 | 69 | 9 | 1.1 | 4.1 | |
| EIRR | | | 6.91% | 11.8% | | | | | | | |

Table 10.2 Mahakanadarawa Sensitivity Analysis Results

| Alternatives | Investment | Op. Cost | Benefits | Standard (Case 1) | Investment | Op. Cost | Benefits |
|--------------|------------|----------|-----------|----------------------|------------|-----------|----------|
| | Plus 10% | Plus 10% | Minus 10% | | Minus 10% | Minus 10% | Plus 10% |
| EIRR | 6.18% | 6.85% | 6.90% | 6.91% | 7.77% | 6.98% | 6.92% |

(2) Wahalkada

The Wahalkada water resource area mainly consists of the DSDs other than Rambewa and Medawachchiya. WTPs of these four DSDs are used. The result of EIRR is 6.59% (Case 1). If CKD benefits are included, the EIRR becomes 11.5%. Case 2 EIRR is 4.46% and lower than that of Case 1 (6.59%).

In order to estimate sensitivity, the investment, operational costs and benefits are changed to plus 10% or minus 10%. The results are shown in Table 10.15. The investment cost change affects the EIRR most, but the difference is only -0.70% or +0.81%. The second most effective change is the operations cost and the difference is -0.10% or +0.09%. The benefit change difference is very small at -0.01% or +0.01%.

The project area covers an area with an extraordinarily high prevalence of CKD and drinking water has a possibility as one of causes for such a disease. Therefore, the people are waiting for

drinking water supply by NWSDB eagerly. Since the cause of CKD is still unknown, the economic analysis was done as a basis for the case of exclusion of medical expenses for CKD and the inclusion case is given as a reference. Anyway, if taking into account the willingness of the people to seek for safe water, it is considered reasonable to use the amount in the economic analysis that the people will be able to pay as willingness-to-pay. In addition, it is difficult to get enough water during the drought season in the project area and the stable water supply by NWSDB is also the great hope of the people and it is reasonable to handle the willingness-to-pay as the benefit from this aspect.

10.5 Toward Sustainability of Operation and Maintenance and What Water Supply Management Should Be

In both cases for Mahakanadarawa and Wahalkada, the revenue is bigger than the O&M cost and it is possible to well manage the proposed water supply system, if there is no investment. Although the investment (cost) is too big resulting in minus FIRR, the business income and expenditure is plus, which makes operations possible. However, it should be noted that depreciation is excluded herein due to a focus of the cash flow. In fact, since the project area is rural, the government bears 80% of the investment while NWSDB shoulders the remaining 20%. In this case, FIRR is plus, namely 0.71% for Mahakanadarawa and 2.0% for Wahalkada, respectively. But when the investment is financed by the loan, the repayment can't be done as long as the interest rate doesn't keep this level of FIRR. It is sure that the revenue over the O&M cost will be maintained.

From the viewpoint what the water supply management should be, the revenue should cover the expenditures including an investment and the principal and interest repayment is possible if FIRR is equal to the interest rate in case of full cover of an investment with a loan. For a private company to operate the water supply business, if the income will be offset by principal and interest repayment with no profit, it is meaningless to make an investment and therefore a company seeks for higher FIRR. It is considered that NWSDB is the public entity and acceptable to such FIRR if it is equal to the interest rate. However, even NWSDB can't manage the business in the situation that FIRR is minus. Therefore, as long as the revenue to maintain FIRR equal to the interest rate in case of an investment financed through a loan is not assured, that is to say, the tariff increase is assured, NWSDB can't operate as a self-support accounting entity. However, the tariff increase is controlled by the government, NWSDB has to receive the subsidy from the government, if so.

For the future direction, if the per capita GDP in Sri Lanka will increase with an average income, the customer will afford to pay the water tariff or should pay the proper water tariff and the government will be released from the policy to control the water tariff in a low level.

On the other hand, if the government is proper, it should accept the tariff increase at least at the level equal to an annual inflation rate (an increment of Consumer Price Index (CPI)). However, the government will setting the equation of $[CPI - \alpha]$ and estimate α as a challenge for productivity improvement to direct NWSDB or negotiate with NWSDB. Since the financial analysis in this report as well as the economical analysis is done with the net, the gross will not be the same as an estimation, as long as the inflation portion will not be added to the actual income and expenditure. That is to say, the revenue, if the tariff will not reflect the inflation, will decrease against the actual cost

CHAPTER 11 Operation and Effect Indicators

To check the progress and effect of the proposed Project, the operation and effect indicators are set as shown in **Table 11.1** and **Table 11.3**, respectively.

11.1 Operation Indicators

The operation indicators are to show to what extent the water supply scheme is operated efficiently, to achieve the target.

In the study area, NWSDB has already operated five water supply schemes in the urban centres of the DSDs except for Rambewa DSD and, in addition, a number of the Community-Based Organizations have operated their own small scale water supply schemes. In this report, the objects are the newly proposed integrated water supply schemes and their service areas in Mahakanadarawa and Wahalkada, respectively, therefore the present situation is regarded as none.

- The served population by pipe borne water supply is obtained from multiplying the number of connections by per housing unit population which is calculated from the number of housing units and population by GND in census 2011 (as of October 1, 2012, data is not declared). This served population included those by CBOs as stated below.
- For reference, as the served population by CBO water supply schemes is unknown, the number of connections shall be reported annually by CBOs to NWSDB RSC(NC) as well as water consumption. The data can be used for calculation of per capita water consumption and NRW ratio in respective CBO water supply schemes using the bulk water supply amount.
- The daily maximum and average water supply amount shall exclude that for miscellaneous use in the water treatment plant.
- Some CBOs shows the high level of NRW ratio. However, in case of bulk water supply to existing CBOs, the practice in CBO water supply schemes is separated from the data of NWSDB and, in addition, almost water transmission and distribution pipes will be newly installed in the Project. The NRW ratio is set as 20% almost nearly equal to the present performance of NWSDB RSC(NC).
- The purpose of this project to supply safe water to customers especially focusing on the Sri Lankan Drinking Standard for a fluoride concentration of 0.6 mg/L. The compliance rate of the said standard should be 100%. The analysis shall be conducted semi-monthly.

11.2 Effect Indicators

The effect indicators shows that the people's living will be comfortable and the risk reduction that may be suffered from skeletal and dental fluorosis as well as chronic kidney diseases.

- The services area is divided into two categories, namely one for pipe borne water supply and the other for water delivery service by bowsers. In the pipe borne water supply service area, water can be used for multi purposes as general domestic water, while in the water delivery service area, water use will be limited to drinking and cooking only due to water-fetching works using plastic tanks, etc. The population coverage for an access to safe water is calculated as the total of both services.
- The identification of served population in the water delivery service by bowsers will be expectedly difficult. For a meanwhile, it is recommended that the practice of water use will be estimated through an questionnaire survey at the people's meeting, etc. and an accuracy in estimation will be enhanced through an improvement of such ways.
- 94% of the people in the project area have already any kinds of existing water sources (almost groundwater). When the water consumption will be rather below an amount estimated from the population coverage ratio, it suggests that the people use water selectively either from well water or tap water. Therefore, the timing of water treatment facility augmentation should be decided based on an increase of actual daily average water consumption but not the population coverage.

- Fluorosis risk rate

When the water source of existing CBO has a fluoride concentration above the Sri Lankan Drinking standard (0.6 mg/L), such served population is defined as the population with a risk for fluorosis. Assuming that the percentage of the population with a risk to the total population within the existing CBO service area is applicable to the entire study area, it can be reduced with the connection to a proposed integrated water supply system

Table 11.2 Fluorosis Risk Avoidance Rate

Mahakanadarawa Service Area

| | | |
|--|--|------------------------|
| Population with a risk for fluorosis (2012) | 16,930 persons | |
| Population with no risk for fluorosis (2012) | 3,135 persons | |
| Percentage of population with a risk (2012) | $16,930 / 20,065 \times 100 = 84.4\%$ | |
| Water supply mode in 2020 | Total population | Served population |
| Pipe borne water supply | 70,680 persons | 40,749 persons (57.7%) |
| Bowser water supply | 21,393 persons | 21,393 persons (100%) |
| Total | 92,073 persons | 62,142 persons (67.5%) |
| Prevalence risk in 2020 | $(92,073 - 62,142) / 92,073 \times 100 = 32.5\%$ | |

Wahalkada Service Area

| | | |
|--|--|------------------------|
| Population with a risk for fluorosis (2012) | 12,530 persons | |
| Population with no risk for fluorosis (2012) | 5,370 persons | |
| Percentage of population with a risk (2012) | $12,530 / 17,600 \times 100 = 71.2\%$ | |
| Water supply mode in 2020 | Total population | Served population |
| Pipe borne water supply | 107,907 persons | 64,077 persons (59.4%) |
| Bowser water supply | 24,615 persons | 24,615 persons (100%) |
| Total | 132,522 persons | 88,692 persons (66.9%) |
| Prevalence risk in 2020 | $(132,522 - 88,692) / 132,522 \times 100 = 33.1\%$ | |

Table 11.1 Operation Indicators for Water supply

Mahakanadarawa System

| Category | Indicators | Calculation Equation of Indicators | Target | | | Purpose |
|----------|--|--|---------|--------|--------|--|
| | | | Present | 2020 | 2024 | |
| Basic | Served population (persons) | Served population by pipe borne water supply = (No. of connections) × (Average per HU population) | 25,900 | 40,700 | 47,800 | |
| | | Served population by bowzers = (total population) | 0 | 21,400 | 22,300 | |
| | | Total served population = Served population + Served population by bowzers | 25,900 | 62,100 | 70,100 | |
| | | Daily maximum water distribution = (the biggest one in the daily water distribution records throughout a year) | 0 | 7,193 | 8,585 | |
| Basic | Water distribution (m ³ /day) | Daily average water distribution = (annual water distribution amount) / (annual days) | 0 | 5,994 | 7,154 | |
| | | Facility utilization rate (Max.) = (Daily maximum water production) / (treatment capacity) × 100 | 0 | 83 | 103 | |
| Basic | Facility utilization rate (%) | Facility utilization rate (Ave.) = (Daily average water production) / (treatment capacity) × 100 | 0 | 70 | 90 | |
| | | No. of samples with a fluoride concentration of below 0.6 mg/L / Total no. of samples * 100 | - | 100 | 100 | Reference: The drinking standard for fluoride is not complied to at 19 schemes out of 24 existing CBOs |
| Basic | NRW ratio (%) | NRW ratio = (NRW volume) / (water distribution) × 100 | - | 20% | 20% | |

Source: Prepared by the Study Team

Table 11.1 Operation Indicators for Water supply (Cont'd)

Wahalkada System

| Category | Indicators | Calculation Equation of Indicators | Target | | | Purpose |
|----------|--|--|---------|--------|---------|--|
| | | | Present | 2020 | 2024 | |
| Basic | Served population (persons) | Served population by pipe borne water supply = (No. of connections) × (Average per HU population) | 26,900 | 64,100 | 74,700 | |
| | | Served population by bowzers = (total population) | 0 | 24,600 | 25,700 | |
| | | Total served population = Served population + Served population by bowzers | 26,900 | 88,700 | 100,400 | |
| | | Daily maximum water distribution = (the biggest one in the daily water distribution records throughout a year) | 0 | 11,203 | 13,318 | |
| Basic | Water distribution (m ³ /day) | Daily average water distribution = (annual water distribution amount) / (annual days) | 0 | 9,336 | 11,098 | |
| | | Facility utilization rate (Max.) = (Daily maximum water production) / (treatment capacity) × 100 | 0 | 78 | 93 | |
| Basic | Facility utilization rate (%) | Facility utilization rate (Ave.) = (Daily average water production) / (treatment capacity) × 100 | 0 | 65 | 77 | |
| | | No. of samples with a fluoride concentration of below 0.6 mg/L / Total no. of samples * 100 | - | 100 | 100 | Reference: The drinking standard for fluoride is not complied to at 13 schemes out of 20 existing CBOs |
| Basic | NRW ratio (%) | NRW ratio = (NRW volume) / (water distribution) × 100 | - | 20% | 20% | |

Table 11.3 Effect Indicators for Water Supply

Mahakanadarawa System

| Cate- gory | Indicators | Calculation Equation of Indicators | Target | | | Purpose |
|---------------|-------------------------------------|---|-------------------|----------|----------|--|
| | | | Present (2012) | 2020 | 2024 | |
| Basic | Population coverage by water supply | (Pipe borne water supply) Population coverage = (Served population) / (Administrative population) × 100 (Water delivery service by bowsers) | 41% | 58% | 64% | Status of risk avoidance being suffered from fluorosis and CKD through shifting of water source from well water to tap water |
| | | Population coverage = (Served population) / (Administrative population) × 100 (Population coverage for an access to safe water) | 0 % | 100% | 100% | |
| | | Population coverage = (Served population) / (Administrative population) × 100 | 31% | 68% | 72% | |
| Basic | Fluoride risk rate | (Fluoride risk rate) = 100 - (Population coverage for an access to safe water) | - | 32% | 28% | The current rate is 84.4% at the existing service area. |
| Assist | Per capita consumption | Per capita daily maximum consumption = (Daily maximum domestic consumption) / (Served population) | 96 Lpcd | 101 Lpcd | 103 Lpcd | Shifting of water source from well water to tap water |
| | | Per capita daily average consumption = (Daily average domestic consumption) / (Served population) | 80 Lpcd | 84 Lpcd | 86 Lpcd | |

Source: Prepared by the Study Team

Table 11.3 Effect Indicators for Water Supply (Cont'd)

Wahalkada System

| Cate- gory | Indicators | Calculation Equation of Indicators | Target | | | Purpose |
|---------------|-------------------------------------|---|-------------------|----------|----------|--|
| | | | Present (2012) | 2020 | 2024 | |
| Basic | Population coverage by water supply | (Pipe borne water supply) Population coverage = (Served population) / (Administrative population) × 100 (Water delivery service by bowzers) | 28% | 59% | 65% | Status of risk avoidance being suffered from fluorosis and CKD through shifting of water source from well water to tap water |
| | | Population coverage = (Served population) / (Administrative population) × 100 (Population coverage for an access to safe water) | 0 % | 100% | 100% | |
| | | Population coverage = (Served population) / (Administrative population) × 100 | 23% | 67% | 72% | |
| Basic | Fluoride risk rate | (Fluoride risk rate) = 100 - (Population coverage for an access to safe water) | - | 33% | 28% | The current rate is 71.2% at the existing service area. |
| Assist | Per capita consumption | Per capita daily maximum consumption = (Daily maximum domestic consumption) / (Served population) | 96 Lpcd | 101 Lpcd | 103 Lpcd | Shifting of water source from well water to tap water |
| | | Per capita daily average consumption = (Daily average domestic consumption) / (Served population) | 80 Lpcd | 84 Lpcd | 86 Lpcd | |

Source: Prepared by the Study Team

CHAPTER 12 Project Risk

12.1 Project Risk

The proposed Project is constructed based on the important preconditions described below. If any of them will be lacking, it may cause a serious problem in the management, operation and maintenance of proposed water supply systems.

(1) Water Availability

This project assures the sustainability of drinking water supply from Mahakanadarawa Wewa and Wahalkada Wewa as water sources under the assumption that the NCP Canal Project and Yan Oya Reservoir Project will be implemented. These irrigation projects will be expectedly completed in the year of 2017 and be commissioned at the time of completion of this integrated water supply project in 2018. However, they have not yet commenced the construction works and it cannot be said that there will be no possibility of delay or suspension. As stated in “**4.3 Water Availability**”, the water balance will be in the tight condition between water use for irrigation and water supply. It can't be foreseen whether the farmers' association will allow with no objection that reservoir water is used for drinking water supply before the completion of the irrigation project. Therefore, the progress of the irrigation projects concerned should be carefully monitored and prompt action be taken to drive the project. as required.

(2) Water Quality of Proposed Water Sources

During the JICA study period covering from May to October 2012, in spite that the study area has experienced the severer drought than usual with no precipitation, the fluoride concentrations of both Mahakanadarawa Wewa and Wahalkada Wewa as the proposed water sources for drinking water supply were 0.52 mg/L and 0.38 mg/, respectively, at the maximum below the Sri Lankan Drinking Water Standard of 0.6 mg/L, although they have shown an increase of fluoride concentrations for April to July. On the Contrary, that of the Yan Oya River has recorded at 1.2 mg/L in July above the Japanese Drinking Water Standard of 0.8 mg/L. There is no problem in terms of the Yan Oya River, since it will not be used for a drinking water source. However, it can't be denied that the basin of proposed water sources has geologically an increasing trend in the dry season. For this reason, fluoride concentrations of both Mahakanadarawa Wewa and Wahalkada Wewa should be monitored subsequently thereafter.

In the North Central Province, water is used repeatedly for irrigation in the cascade irrigation system. If agricultural chemicals are used frequently in their basins, the reservoirs receive the

influent with condensed agricultural chemicals. Although according to the water quality examination results for proposed water sources covering the period from November 2011 to April 2012, any abnormal values have not been found in pesticide residues and toxic chemical requirements such as arsenic, cadmium, cyanide, lead, selenium and chromium, attention be paid for the use of agricultural chemicals in their basins and measures to ban their use should be taken to ensure the safety of water sources for drinking water, if required.

(3) Increase of Coverage and Water Demand in the Proposed Water Supply System

In the project area, a high fluoride concentration in groundwater used for drinking water causes the dental fluorosis and is suspected as one of causative substances for chronic kidney diseases (CKDs) which occur in a high level especially in the area. Therefore, the shift of water source from groundwater to surface water with a less fluoride concentration is desired earnestly. For this reason, the people have great expectations for the project and the willingness to connect the new integrated water supply system is considered to be high. However, as NWSDB has so far experienced the difficulty to increase the coverage by pipe borne water supply in the rural area, it is a risk to over-estimate such situations with the following reasons:

- In the project area, the percentage of household population below poverty line is relatively high in the district.
- Almost people have another water sources and the connection to a new pipe borne water supply is left to the people's discretion.
- Even though connecting to a new system, there is the possibility of selective use of either groundwater or tap water.
- The increase of connections has not been so high even in water supply schemes operated by NWSDB in the project area
- It is expected to take a long time to achieve the 100% coverage by pipe borne water supply in the project area due to a very low population density.

It depends on to what extent those problems can be overcome through an awareness campaign to the people. Attention be paid for not only the coverage but also the increase of actual water consumption.

If actual water consumption will be less than the estimation, the income will be decreased resulting in a heavy financial burden on NWSDB.

12.2 Considerations in Planning

(1) Geological Survey Not Conducted for Some Facility Sites

The geological survey for some facility sites such as elevated tanks, intake works, etc. couldn't be conducted from some reasons during the study period. It should be noted that the preliminary design of such facilities was done based on the assumption that the general geological characteristics obtained from other sites surveyed in the project area can be applicable to the above sites.

(2) Quanty Survey for Distribution Systems

Since the project area is too huge and the communities are located sparsely, the topographic survey was not done for a water distribution system as well as the designing. The size and length of water distribution pipes given in this report are estimated by selecting the model area in the project are, conducting a distribution network analysis, checking the pipe length by size, applying the per connection pipe length by size to the entire project area. It should be therefore noted that such size and length of distribution pipes will not correspond to the actual requirement.