

3 SECTION @ PIER
SCALE 1/200

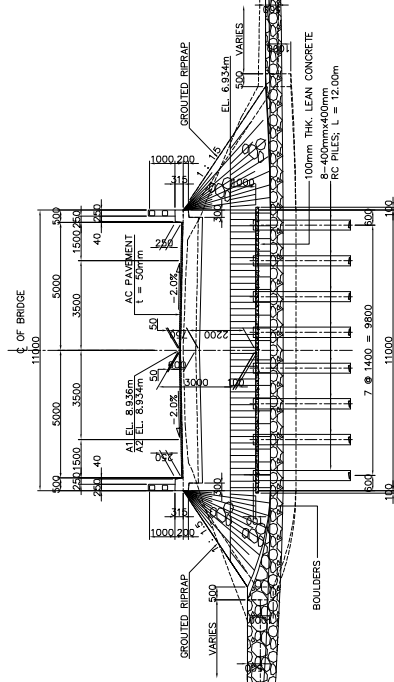

4 SECTION @ ABUT. A2
SCALE 1/200

MINISTRY OF PUBLIC WORKS AND TRANSPORT (MPWT)	THE PROJECT FOR FLOOD DISASTER REHABILITATION AND MITIGATION IN THE KINGDOM OF CAMBODIA	JAPAN INTERNATIONAL COOPERATION AGENCY KATAHIRA & ENGINEERS INTERNATIONAL	TITLE: CLV-1 TKOV II BRIDGE GENERAL VIEW	SCALE	Drawing No.
				AS SHOWN	6-2
					Sheet No.

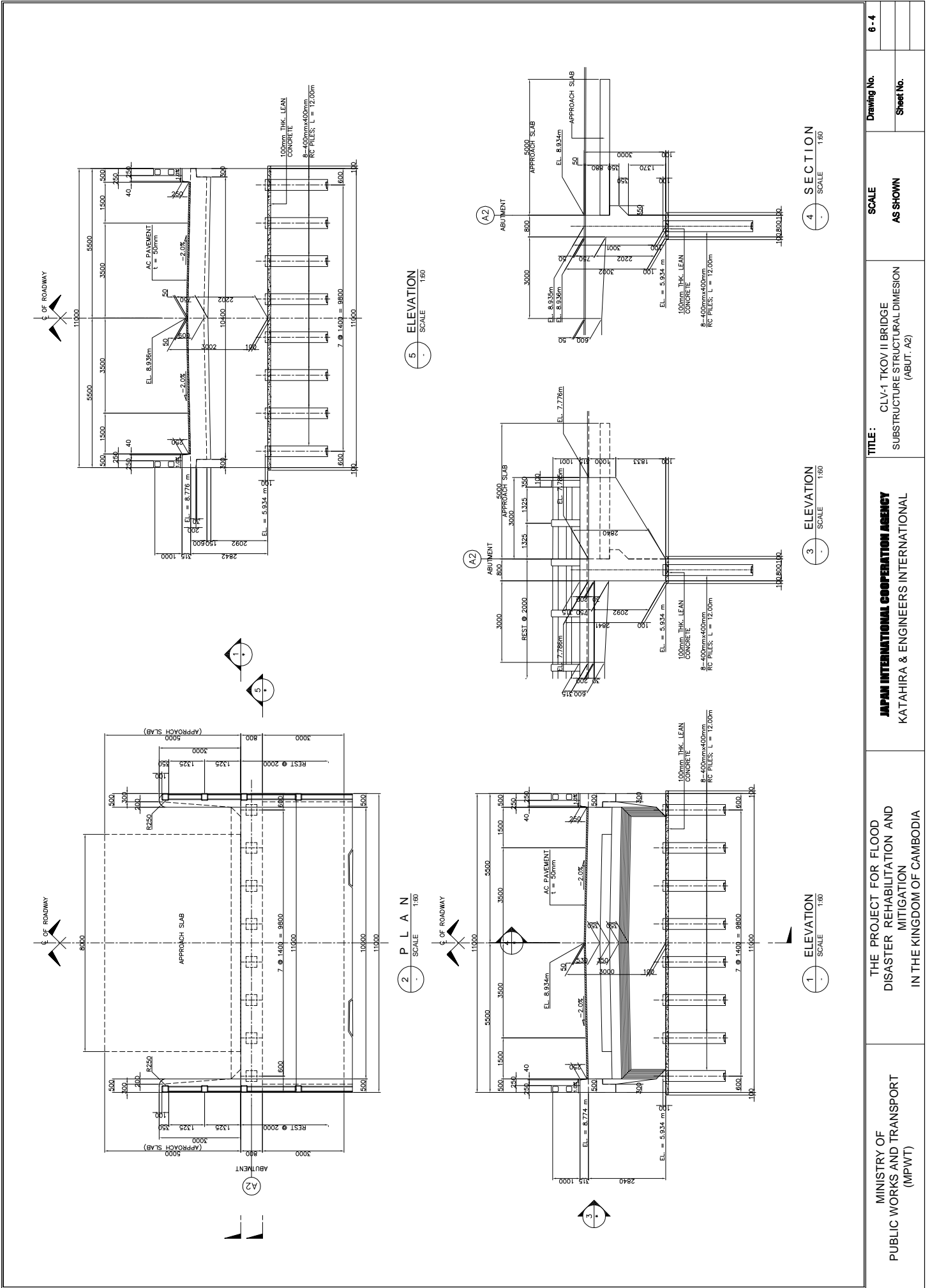

MINISTRY OF PUBLIC WORKS AND TRANSPORT (MPWT)	THE PROJECT FOR FLOOD DISASTER REHABILITATION AND MITIGATION IN THE KINGDOM OF CAMBODIA	JAPAN INTERNATIONAL COOPERATION AGENCY KATAHIRA & ENGINEERS INTERNATIONAL	TITLE : CLV-1 TKOV II BRIDGE SUBSTRUCTURE STRUCTURAL DIMENSION (ABUT. A2)	SCALE	AS SHOWN	Drawing No.	6-4
				AS SHOWN		Sheet No.	

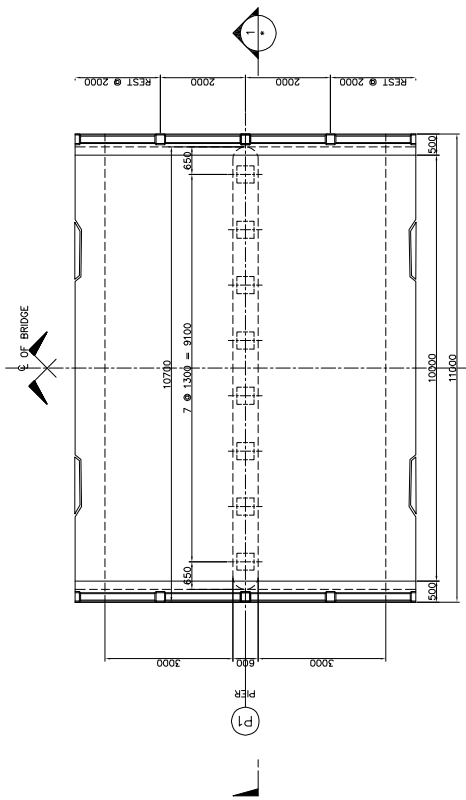

2 PLAN SCALE 1:180

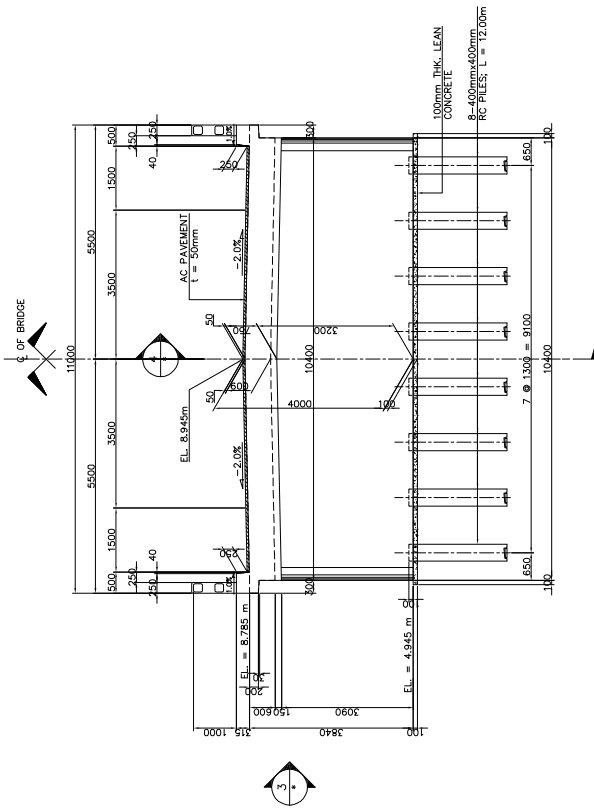

1 ELEVATION SCALE 1:180

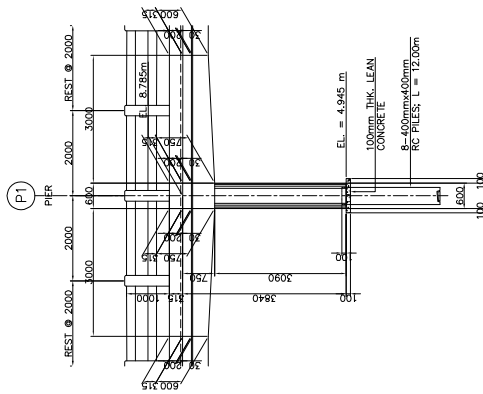

3 ELEVATION SCALE 1:180

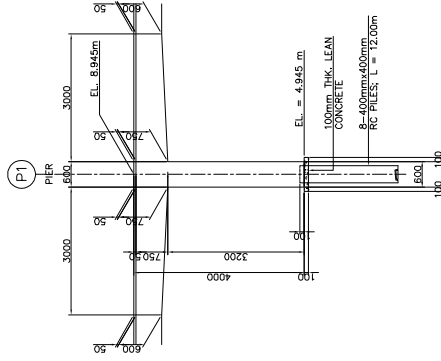

4 SECTION SCALE 1:180

MINISTRY OF
PUBLIC WORKS AND TRANSPORT
(MPWT)

THE PROJECT FOR FLOOD
DISASTER REHABILITATION AND
MITIGATION
IN THE KINGDOM OF CAMBODIA

JAPAN INTERNATIONAL COOPERATION AGENCY
KATAHIRA & ENGINEERS INTERNATIONAL

TITLE:
CLV-1 TKOV II BRIDGE
SUBSTRUCTURE STRUCTURAL DIMENSION
(PIER P1)

SCALE
AS SHOWN

Drawing No.
Sheet No.

6-5

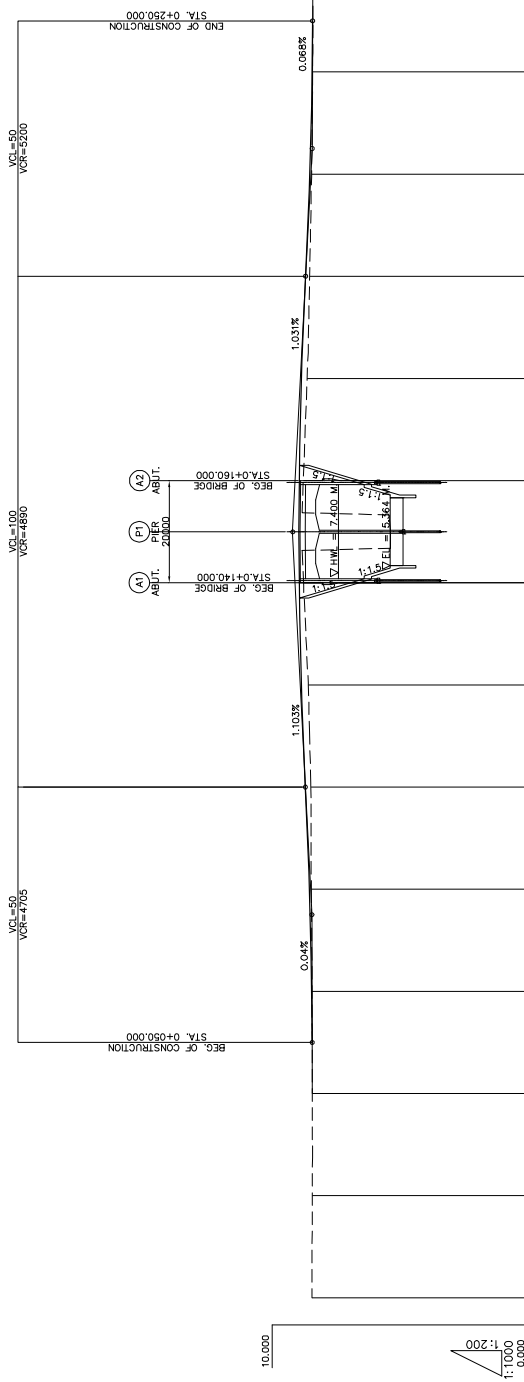

VERTICAL ALIGNMENT	PAVEMENT LEVEL	GROUND LEVEL	STATION	HORIZONTAL ALIGNMENT	SUPER-ELEVATION	WIDENING
8.427	8.442	8.42	0+000			
8.440	8.529	8.46	0+080			
8.693	8.693	8.48	0+100			
8.585	8.585	8.58	0+120			
8.77	8.934	8.77	0+160			
8.684	8.684	8.53	0+200			
8.517	8.517	8.45	0+220			
8.426	8.426	8.41	0+240			
8.410	8.410	8.39	0+260			
8.41	8.41	8.41	0+300			

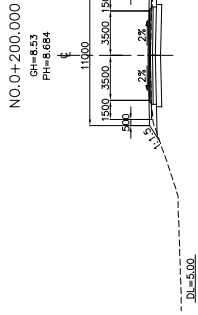
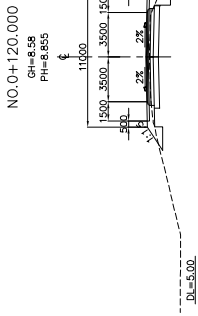
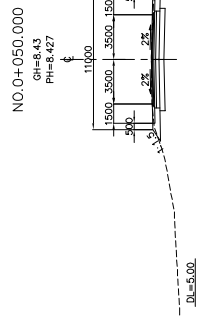
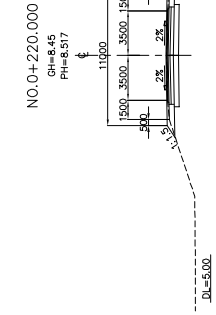
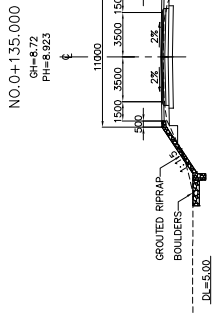
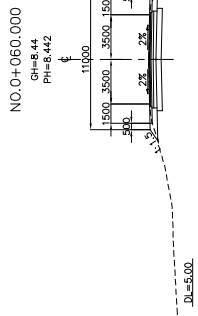
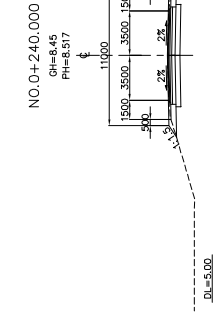
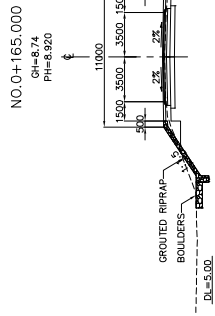
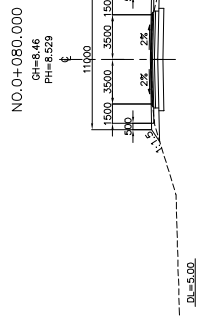
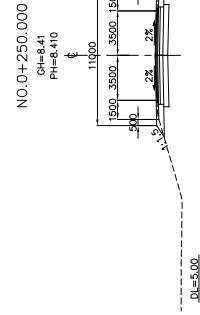
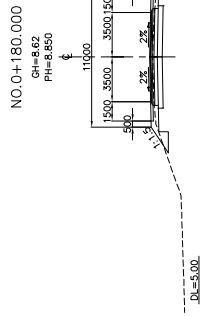
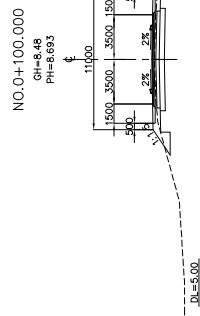

MINISTRY OF
PUBLIC WORKS AND TRANSPORT
(MPWT)

THE PROJECT FOR FLOOD
DISASTER REHABILITATION AND
MITIGATION
IN THE KINGDOM OF CAMBODIA

JAPAN INTERNATIONAL COOPERATION AGENCY
KATAHIRA & ENGINEERS INTERNATIONAL

TITLE:
CLV-1 TKOV II BRIDGE
APPROACH ROAD CROSS SECTION S

SCALE
1:400

Drawing No.
Sheet No.

6-7

BR-11 EK REAM BRIDGE

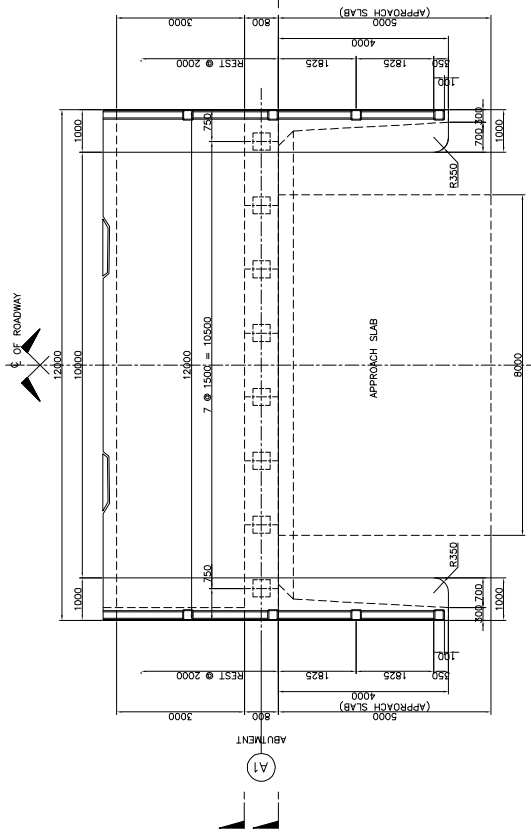

2 PLAN SCALE 1:60

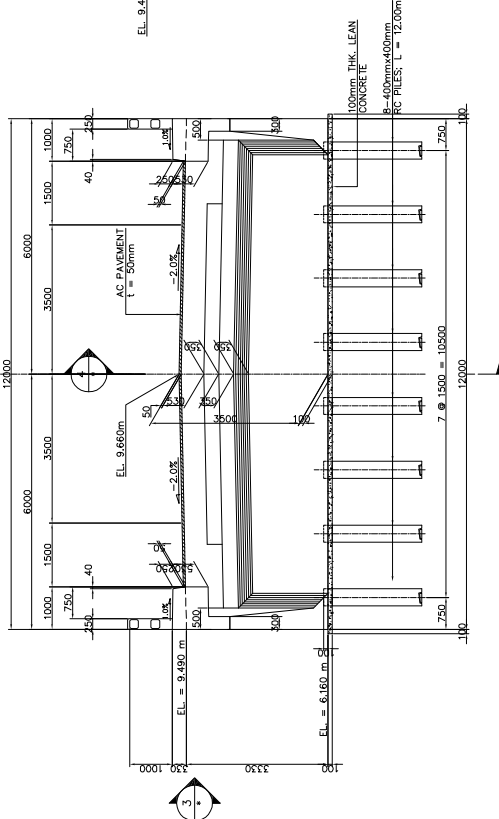
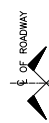

1 ELEVATION SCALE 1:60

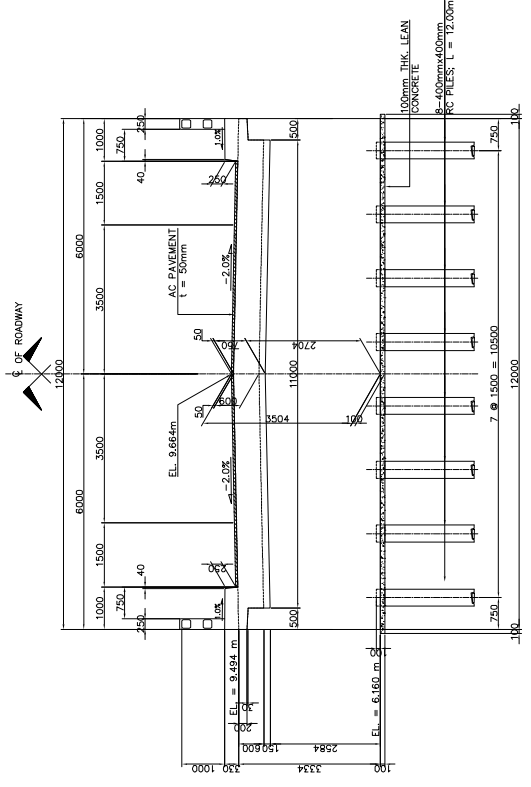

5 ELEVATION SCALE 1:60

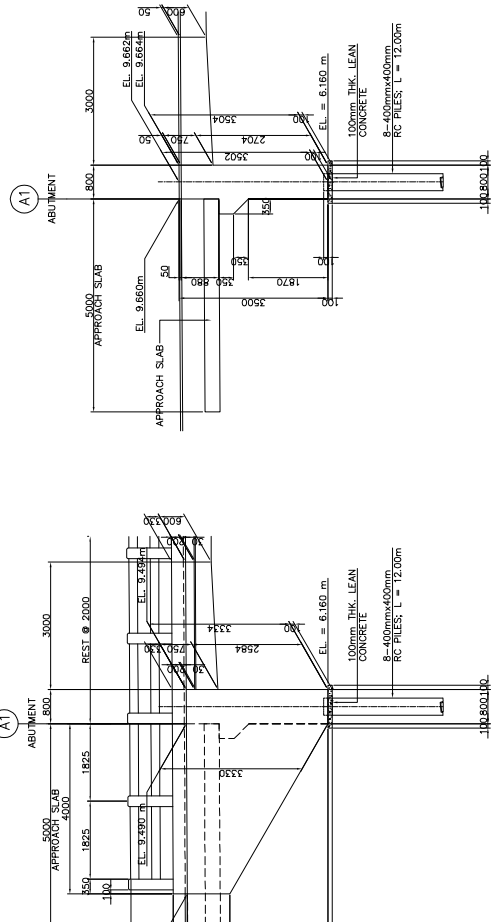

3 ELEVATION SCALE 1:60

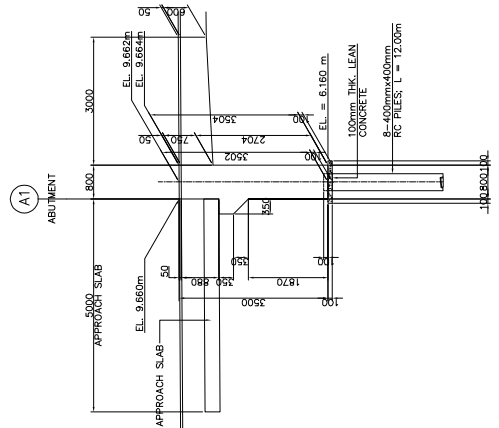

4 SECTION SCALE 1:60



<p>MINISTRY OF PUBLIC WORKS AND TRANSPORT (MPWT)</p>	<p>THE PROJECT FOR FLOOD DISASTER REHABILITATION AND MITIGATION IN THE KINGDOM OF CAMBODIA</p>	<p>JAPAN INTERNATIONAL COOPERATION AGENCY KATAHIRA & ENGINEERS INTERNATIONAL</p>	<p>TITLE: BR-11 EK REAM BRIDGE SUBSTRUCTURE STRUCTURAL DIMENSION (ABUT. A1)</p>	<p>SCALE AS SHOWN</p>	<p>Drawing No. 7-3</p>
					<p>Sheet No.</p>

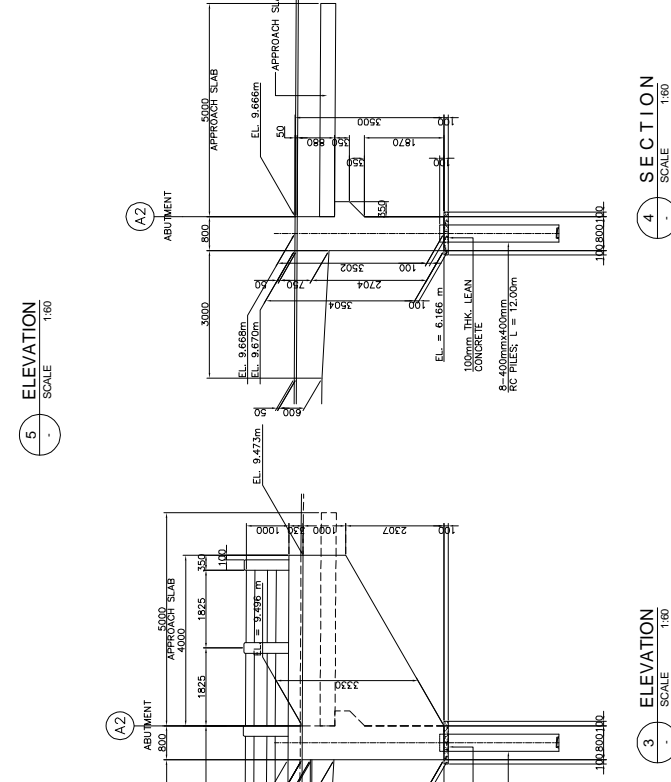
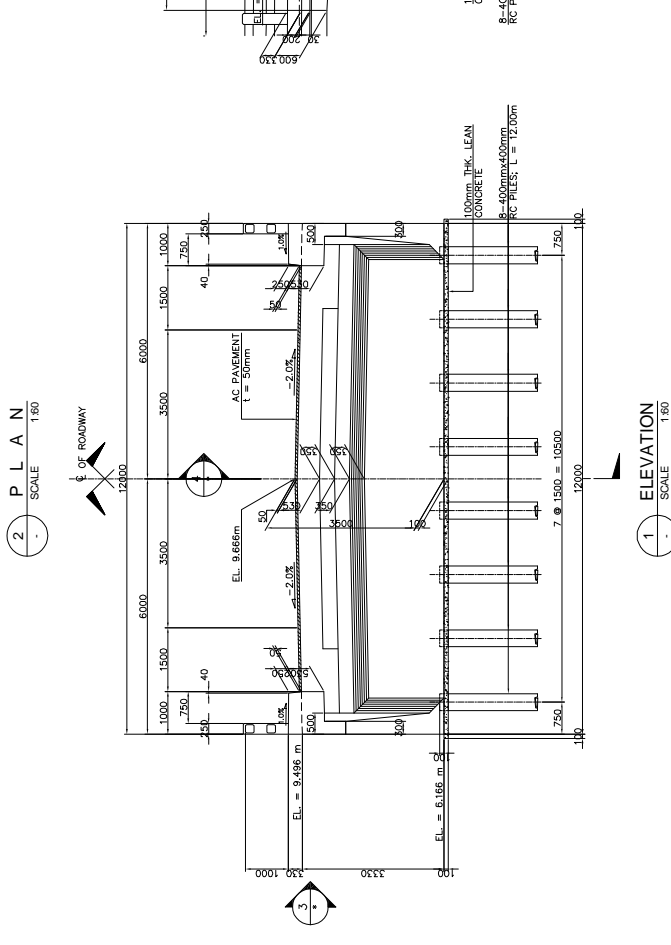
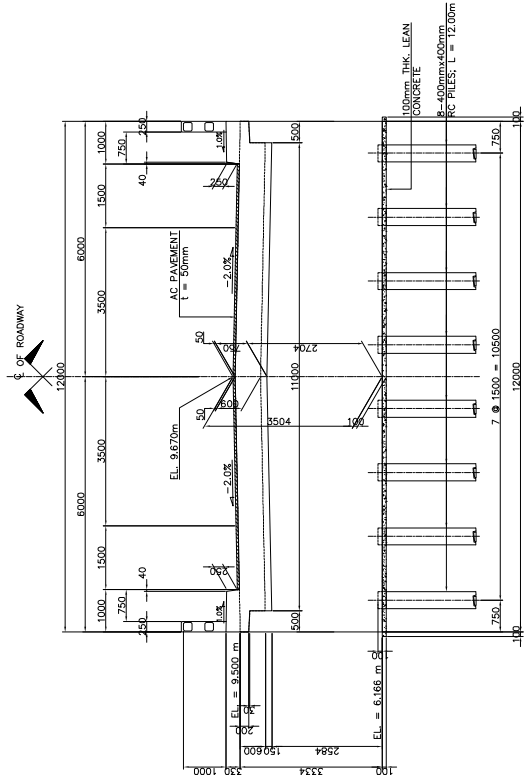
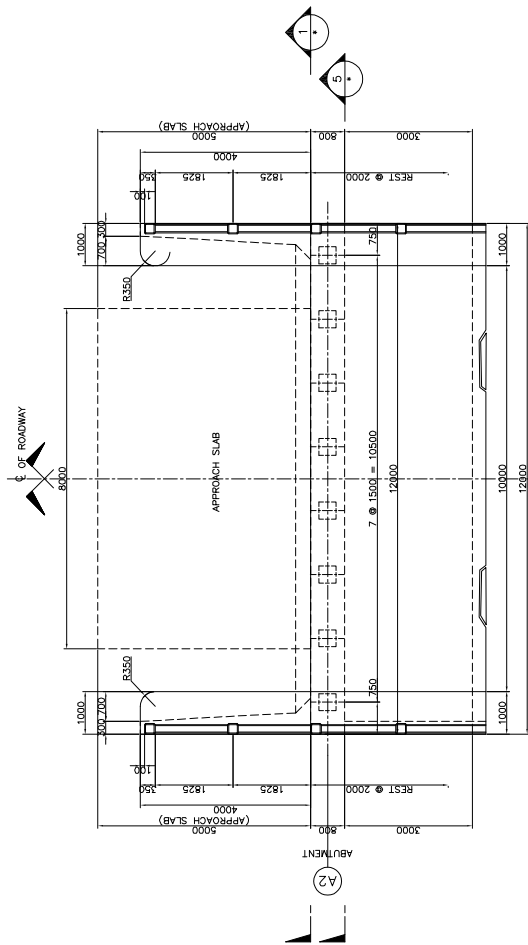

MINISTRY OF PUBLIC WORKS AND TRANSPORT (MPWT)	THE PROJECT FOR FLOOD DISASTER REHABILITATION AND MITIGATION IN THE KINGDOM OF CAMBODIA	JAPAN INTERNATIONAL COOPERATION AGENCY KATAHIRA & ENGINEERS INTERNATIONAL	TITLE : BR-11 EK REAM BRIDGE SUBSTRUCTURE STRUCTURAL DIMENSION (ABUT. A2)	SCALE	Drawing No.
				AS SHOWN	7-4
					Sheet No.

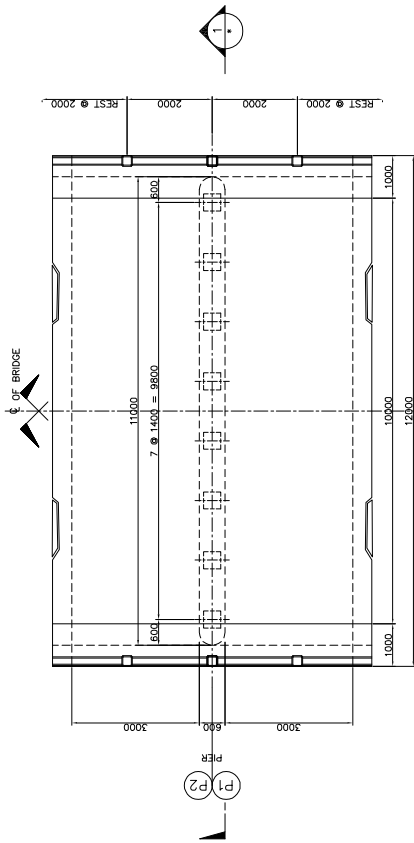
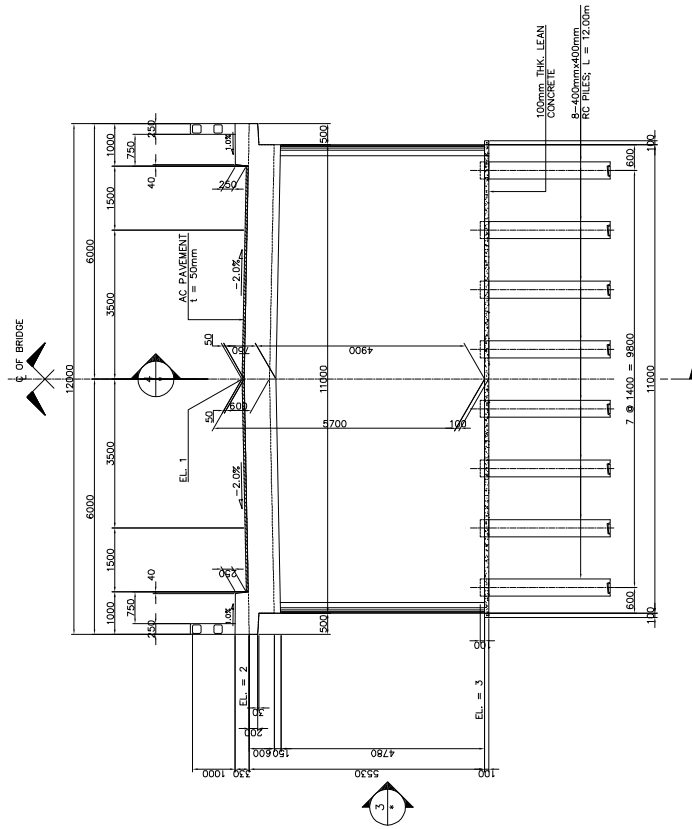

TABLE OF ELEVATIONS

LOCATION	EL. 1	EL. 2	EL. 3
PIER 1	9.700m	9.530m	4.000m
PIER 2	9.702m	9.532m	4.002m

2 PLAN SCALE 1:60



1 ELEVATION SCALE 1:60

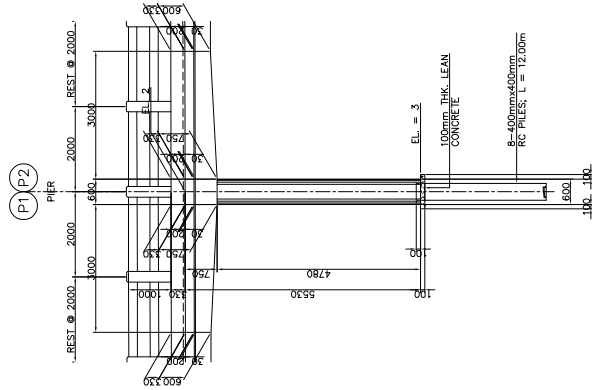

3 ELEVATION SCALE 1:60

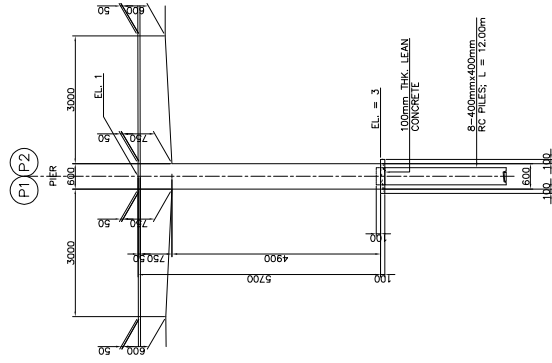

4 SECTION SCALE 1:60

MINISTRY OF PUBLIC WORKS AND TRANSPORT (MPWT)

THE PROJECT FOR FLOOD DISASTER REHABILITATION AND MITIGATION IN THE KINGDOM OF CAMBODIA

JAPAN INTERNATIONAL COOPERATION AGENCY KATAHIRA & ENGINEERS INTERNATIONAL

TITLE: BR-11 EK REAM BRIDGE SUBSTRUCTURE STRUCTURAL DIMENSION (PIER P1 & P2)

SCALE AS SHOWN

Drawing No. Sheet No.

7-5

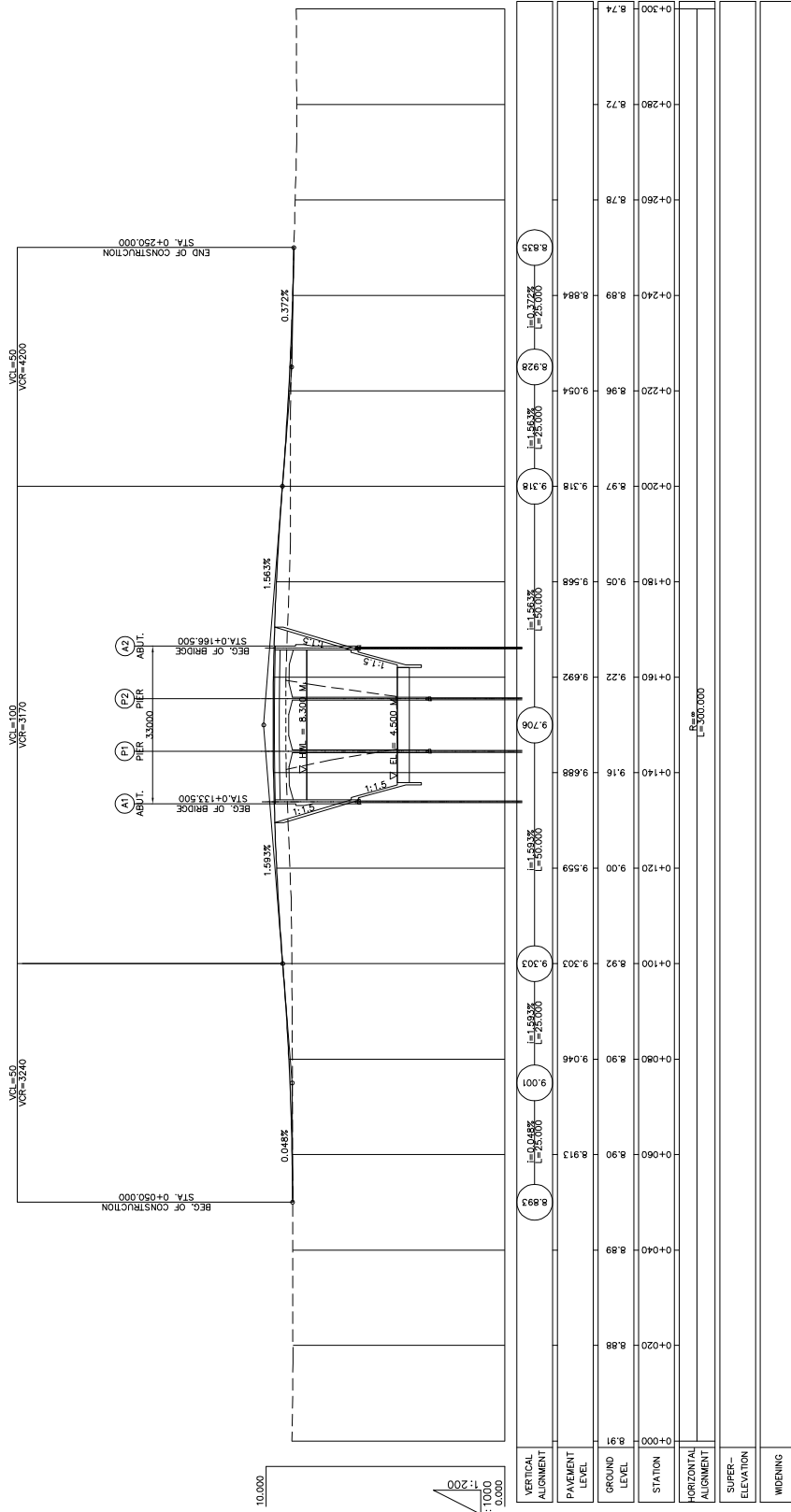

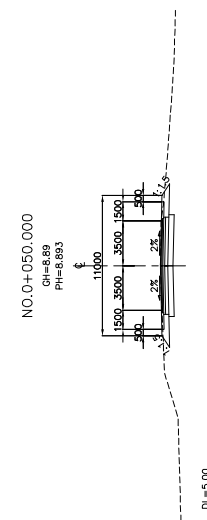
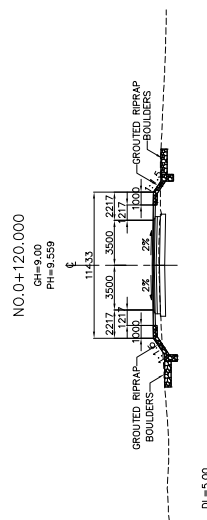
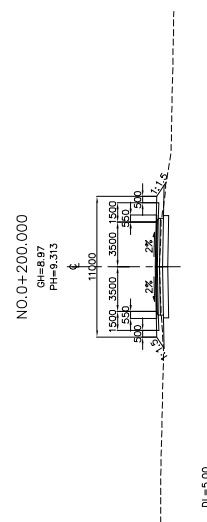
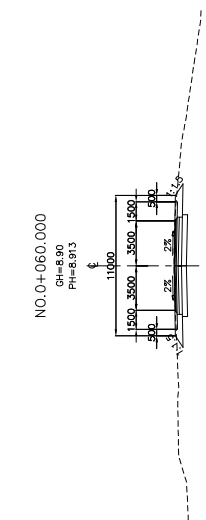
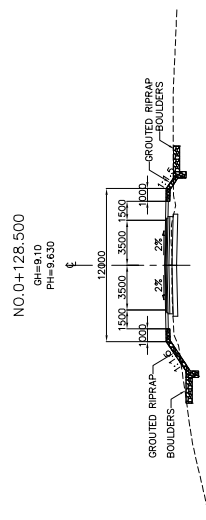
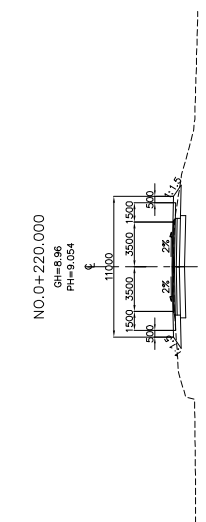
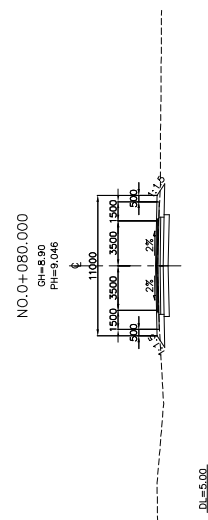
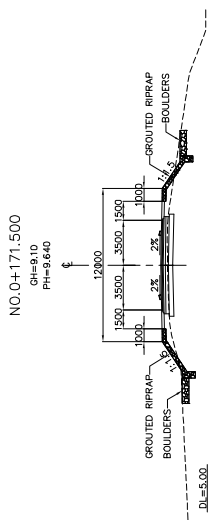
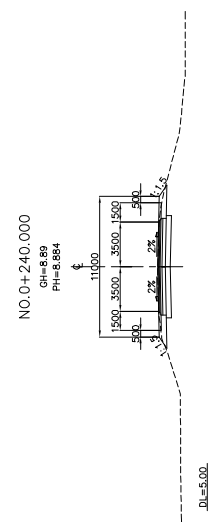
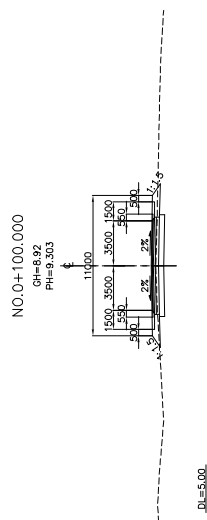
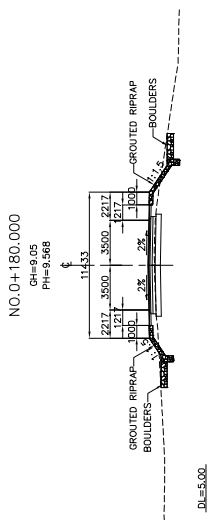
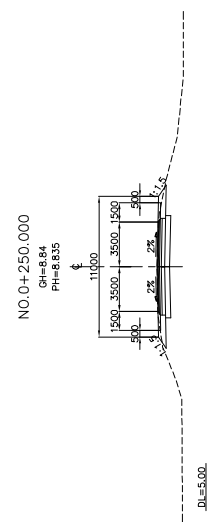

MINISTRY OF PUBLIC WORKS AND TRANSPORT (MPWT)	THE PROJECT FOR FLOOD DISASTER REHABILITATION AND MITIGATION IN THE KINGDOM OF CAMBODIA	JAPAN INTERNATIONAL COOPERATION AGENCY KATAHIRA & ENGINEERS INTERNATIONAL	TITLE : BR-11 EK REAM BRIDGE APPROACH ROAD CROSS SECTIONS	SCALE	Drawing No.
				1 : 400	7 - 7
				Sheet No.	

CLV-2 ROM LECH BRIDGE



ELEMENTS OF CURVE

PI NO.	STATION	COORDINATES	Δ	R	T	Lc	E	e%	W	V(kph)
PI-00	-0+168.836	NORTHING 1256771.391 EASTING 535820.506								
PI-01	-0+021.995	1256688.857 535930.336	25277.96°	650.00	146.841	288.834	16.380	*		
PI-03	0+300.000	1257169.822 536057.797								

NO HORIZONTAL CURVE
NO HORIZONTAL CURVE

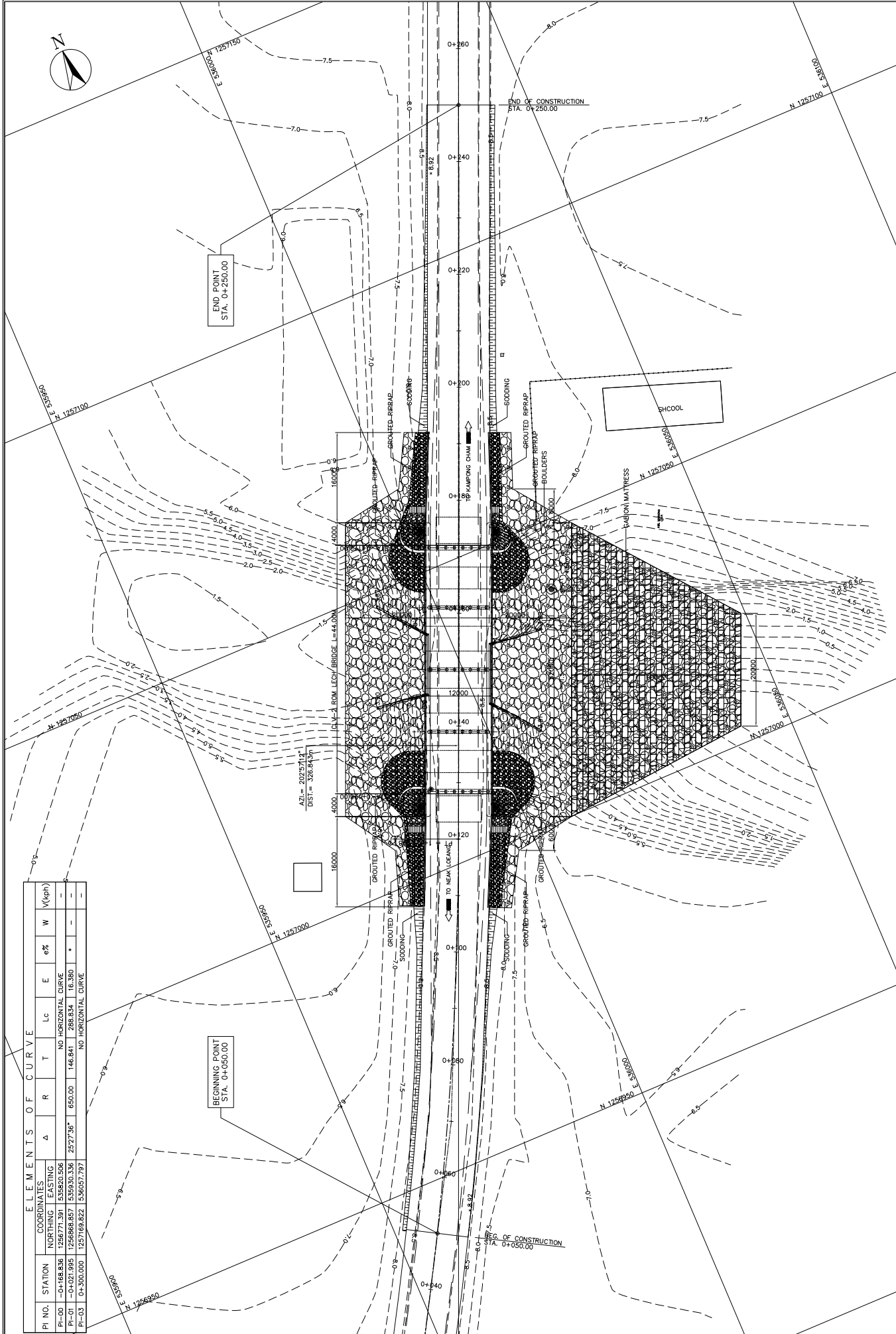

Drawing No.	8 - 1
	Sheet No.
SCALE	1:600
TITLE:	CLV-2 ROM LECH BRIDGE GENERAL SITE PLAN
JAPAN INTERNATIONAL COOPERATION AGENCY KATAHIRA & ENGINEERS INTERNATIONAL	
THE PROJECT FOR FLOOD DISASTER REHABILITATION AND MITIGATION IN THE KINGDOM OF CAMBODIA	
MINISTRY OF PUBLIC WORKS AND TRANSPORT (MPWT)	

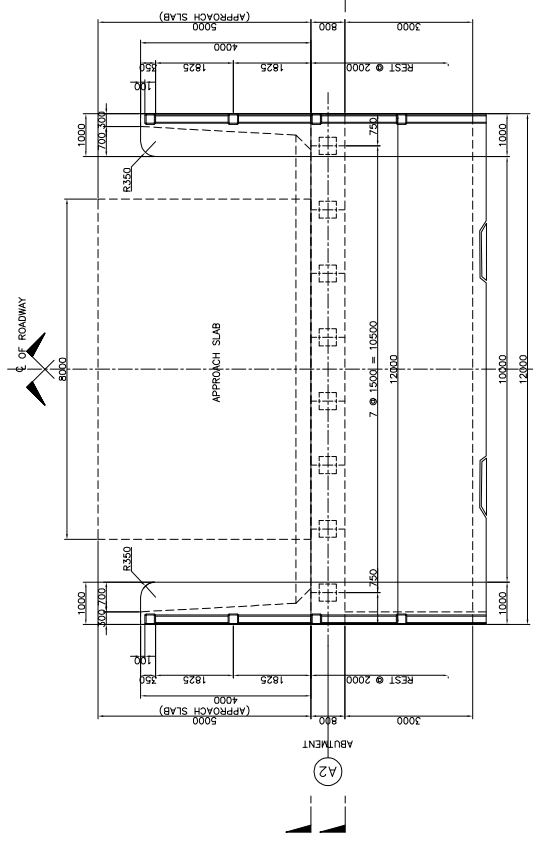

2 PLAN SCALE 1:60

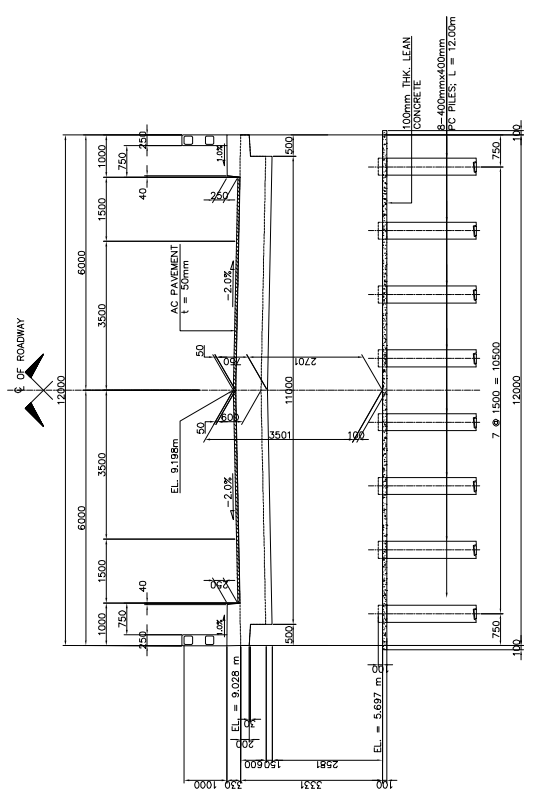

5 ELEVATION SCALE 1:60

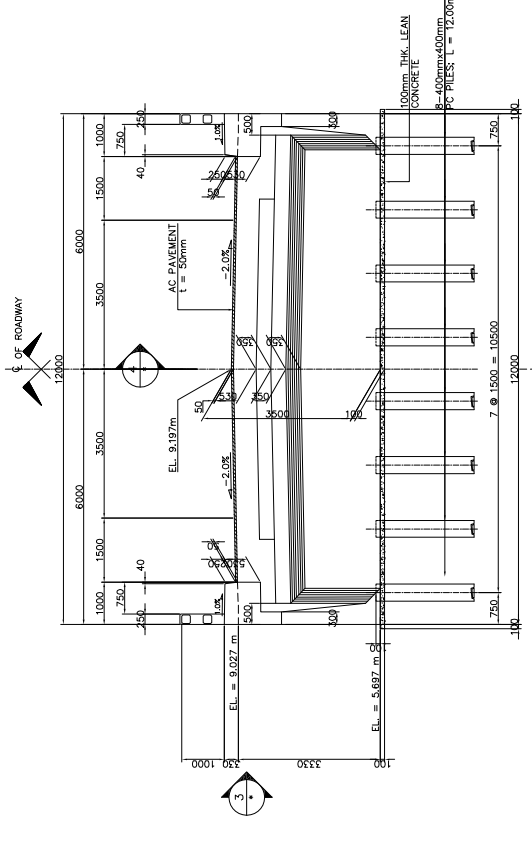

1 ELEVATION SCALE 1:60

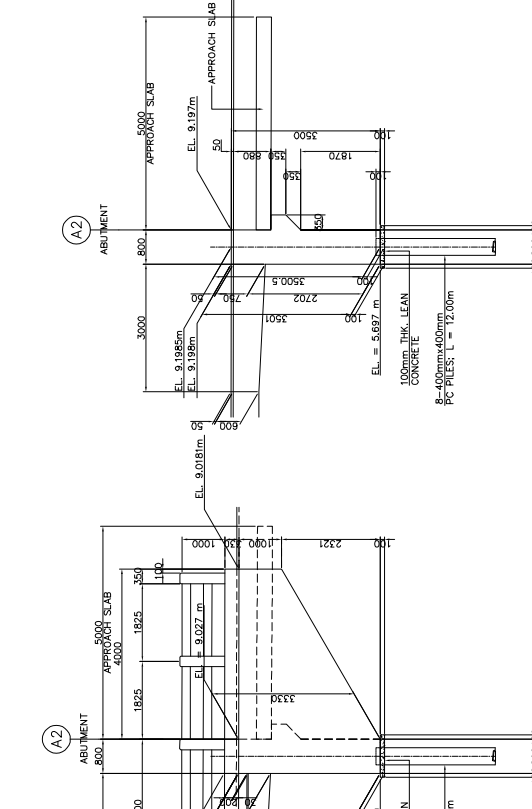

3 ELEVATION SCALE 1:60

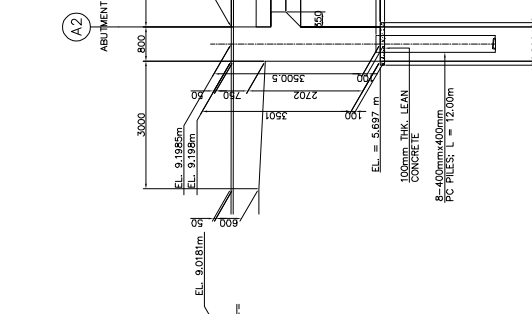

4 SECTION SCALE 1:60

MINISTRY OF PUBLIC WORKS AND TRANSPORT (MPWT)

THE PROJECT FOR FLOOD DISASTER REHABILITATION AND MITIGATION IN THE KINGDOM OF CAMBODIA

JAPAN INTERNATIONAL COOPERATION AGENCY KATAHIRA & ENGINEERS INTERNATIONAL

TITLE: CLV-2 ROM LECH BRIDGE SUBSTRUCTURE STRUCTURAL DIMENSION (ABUT. A2)

SCALE AS SHOWN

Drawing No. Sheet No.

8-4

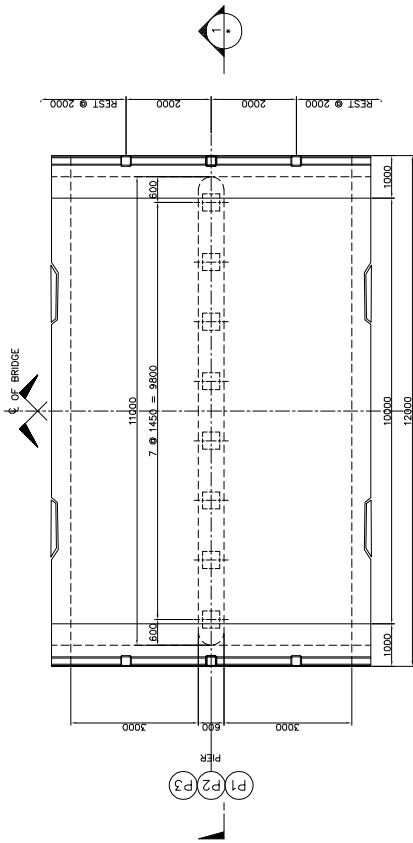
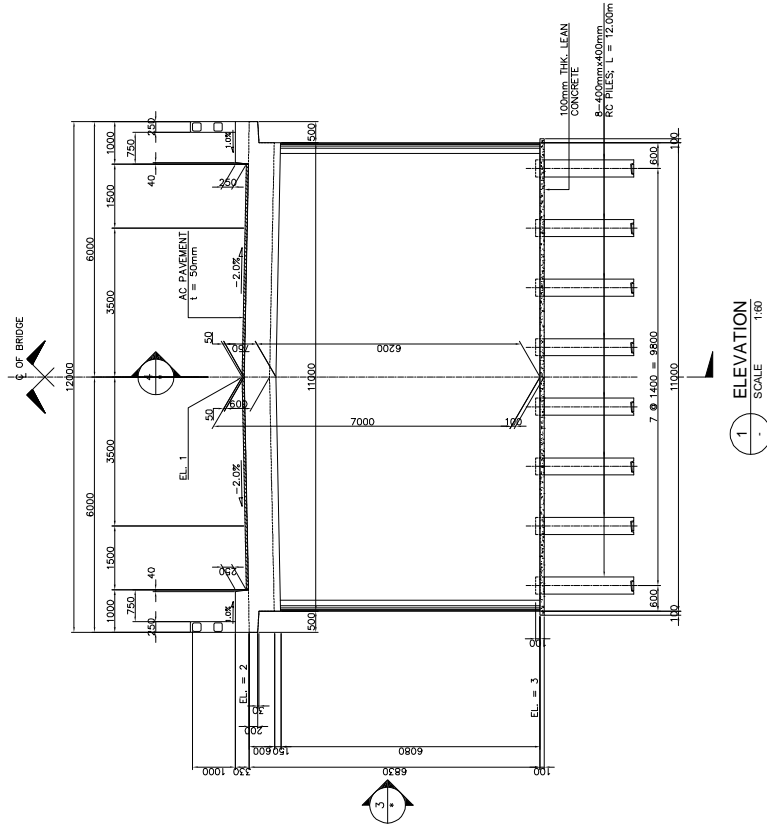

TABLE OF ELEVATIONS

LOCATION	EL. 1	EL. 2	EL. 3
PIER 1	9.171m	9.001m	2.171m
PIER 2	9.199m	9.029m	2.199m
PIER 3	9.208m	9.038m	2.208m

2 PLAN SCALE 1:60



1 ELEVATION SCALE 1:60

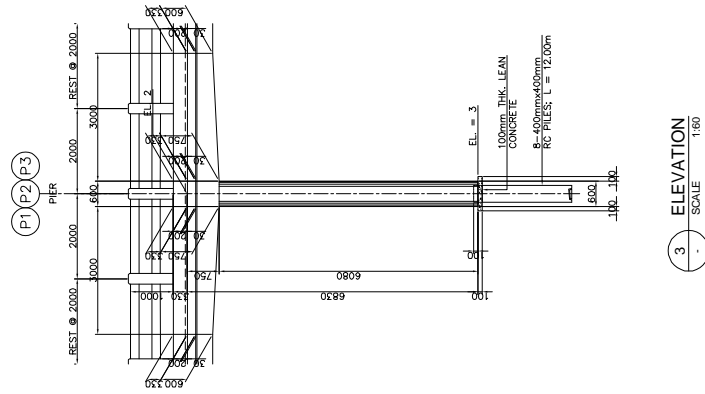

3 ELEVATION SCALE 1:60

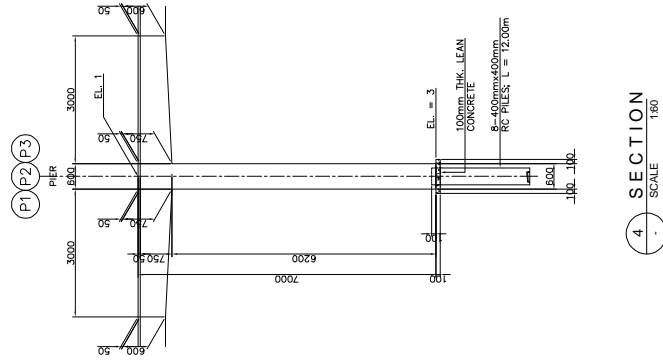

4 SECTION SCALE 1:60

MINISTRY OF PUBLIC WORKS AND TRANSPORT (MPWT)

THE PROJECT FOR FLOOD DISASTER REHABILITATION AND MITIGATION IN THE KINGDOM OF CAMBODIA

JAPAN INTERNATIONAL COOPERATION AGENCY KATAHIRA & ENGINEERS INTERNATIONAL

TITLE: CLV-2 ROM LECH BRIDGE SUBSTRUCTURE STRUCTURAL DIMENSION (PIER P1, P2 & P3)

SCALE AS SHOWN

Drawing No.

Sheet No.

8 - 5

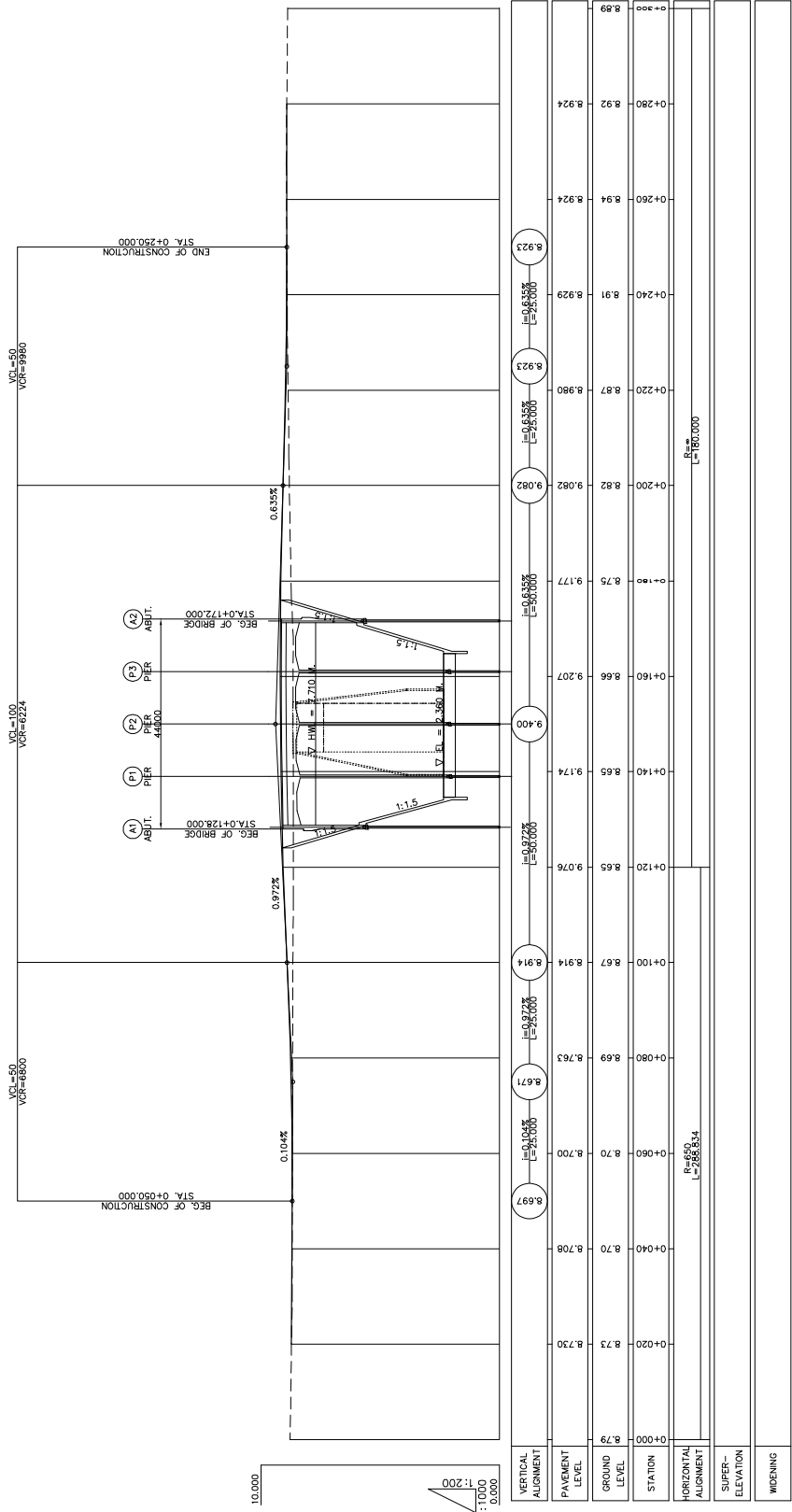

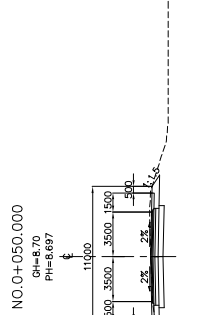
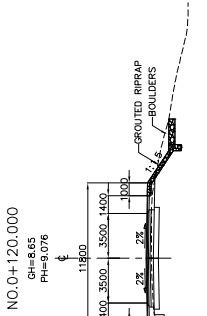
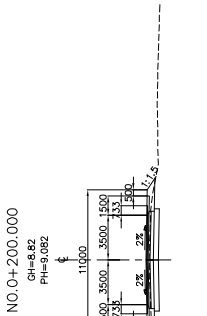
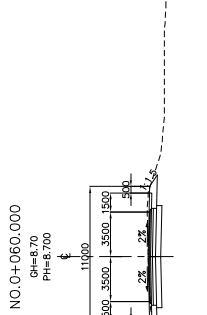
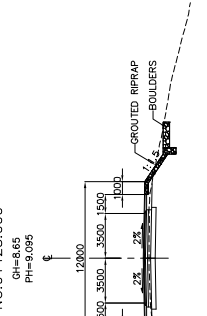
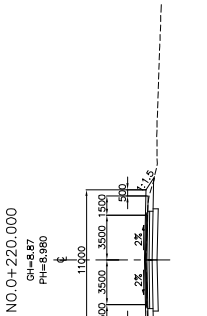
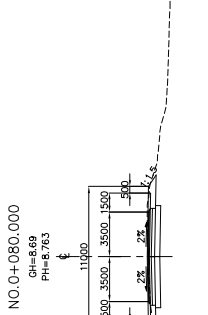
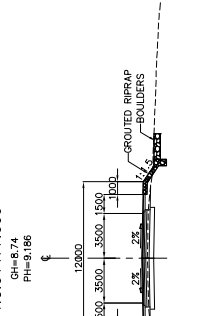
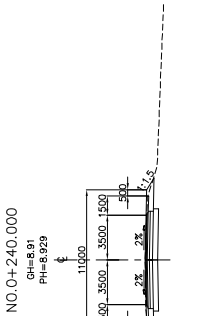
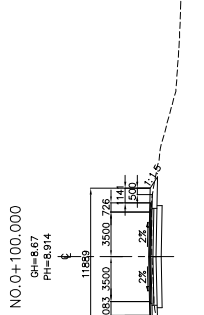
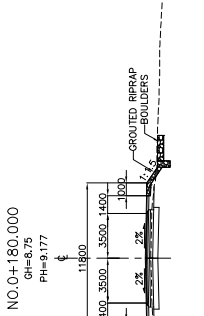
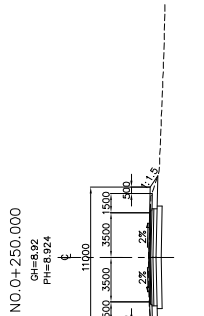

<p>MINISTRY OF PUBLIC WORKS AND TRANSPORT (MPWT)</p>	<p>THE PROJECT FOR FLOOD DISASTER REHABILITATION AND MITIGATION IN THE KINGDOM OF CAMBODIA</p>	<p>JAPAN INTERNATIONAL COOPERATION AGENCY KATAHIRA & ENGINEERS INTERNATIONAL</p>	<p>TITLE : CLV-2 ROM LECH BRIDGE APPROACH ROAD CROSS SECTIONS</p>	<p>SCALE 1 : 400</p>	<p>Drawing No. 8 - 7 Sheet No.</p>
--------------------------------------------------------------	------------------------------------------------------------------------------------------------------------	-------------------------------------------------------------------------------------------------	----------------------------------------------------------------------------------	---------------------------------	------------------------------------------------------

DETAILS OF STANDARD STRUCTURES

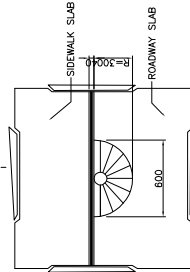
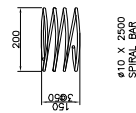
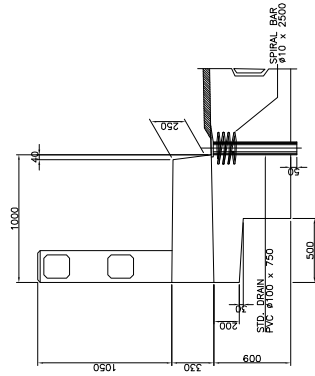
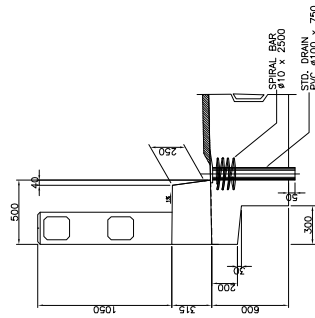
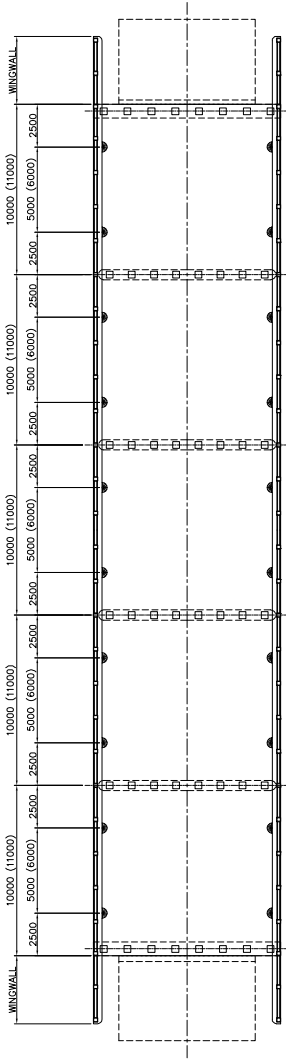

BRIDGE NO.	BRIDGE NAME	BRIDGE LENGTH	SPAN LAYOUT	NO. OF DECK, DRAW
BR-4	ASAL BEUJING	33.00m	3 x 11m	12
BR-5	KATE BEUJING	40.00m	4 x 10m	16
BR-7	SOM RUPHOR II	45.00m	5 x 10m	20
BR-8	MESON	44.00m	4 x 11m	16
BR-9	TKOV	20.00m	2 x 10m	8
CUV-1	KA REAM	33.00m	3 x 11m	12
BR-11	ROM LECH	44.00m	4 x 11m	16
CUV-2				

1 TYPICAL DRAIN DETAILS
SCALE 1:20

1A SECTION
SCALE 1:20

MINISTRY OF
PUBLIC WORKS AND TRANSPORT
(MPWT)

THE PROJECT FOR FLOOD
DISASTER REHABILITATION AND
MITIGATION
IN THE KINGDOM OF CAMBODIA

JAPAN INTERNATIONAL COOPERATION AGENCY
KATAHIRA & ENGINEERS INTERNATIONAL

TITLE:
STANDARD DRAWINGS
TYPICAL DECK DRAIN DETAILS

SCALE
AS SHOWN

Drawing No.

Sheet No.

9-2

BRIDGE NAME	LOCATION	TOTAL PILE LENGTH	NO. OF PILES
BR. 4 KBAL BOEUNG	ABUT. A1	12.00m.	8
	PIERS, P1, P2	12.00m.	8
	ABUT. A2	12.00m.	8
BR. 5 SNAKE	ABUT. A1	12.00m.	8
	PIERS, P1, P2 & P3	15.00m.	8
	ABUT. A2	12.00m.	8
BR. 7 SAM PUTHOR II	ABUT. A1	12.00m.	8
	PIERS, P1, P2 & P3	12.00m.	8
	ABUT. A2	12.00m.	8
BR. 8 MEBON	ABUT. A1	12.00m.	8
	PIERS, P1, P2, P3 & P4	12.00m.	8
	ABUT. A2	12.00m.	8
BR. 9 TKOV I	ABUT. A1	12.00m.	8
	PIERS, P1, P2 & P3	12.00m.	8
	ABUT. A2	12.00m.	8
CLV-1 TKOV II	PIERS, P1	12.00m.	8
	ABUT. A2	12.00m.	8
	ABUT. A1	12.00m.	8
BR. 11 EK REAM	ABUT. A1	12.00m.	8
	PIERS, P1, P2	12.00m.	8
	ABUT. A2	12.00m.	8
CLV-2 ROM LECH	ABUT. A1	12.00m.	8
	PIERS, P1, P2 & P3	12.00m.	8
	ABUT. A2	12.00m.	8

BAR SCHEDULE OF RC PILE

PILE LENGTH	BAR MARK	BAR SIZE	BAR LENGTH	QTY.	UNIT WT.	PER BAR	TOTAL WT.
L = 12.00m	P1	025	12.000	8	3.853	48.236	388.89
	P2	D10	1.400	117	0.617	0.864	101.06
	P3	D10	1.200	20	0.617	0.740	14.81
SUB TOTAL =					485.76	Kg	
CONCRETE CLASS E. VOL. = 1.88 CU. M.							
L = 15.00m	P1	025	15.000	8	3.853	57.795	462.36
	P2	D10	1.400	147	0.617	0.864	126.98
	P3	D10	1.200	20	0.617	0.740	14.81
SUB TOTAL =					604.15	Kg	
CONCRETE CLASS E. VOL. = 2.36 CU. M.							

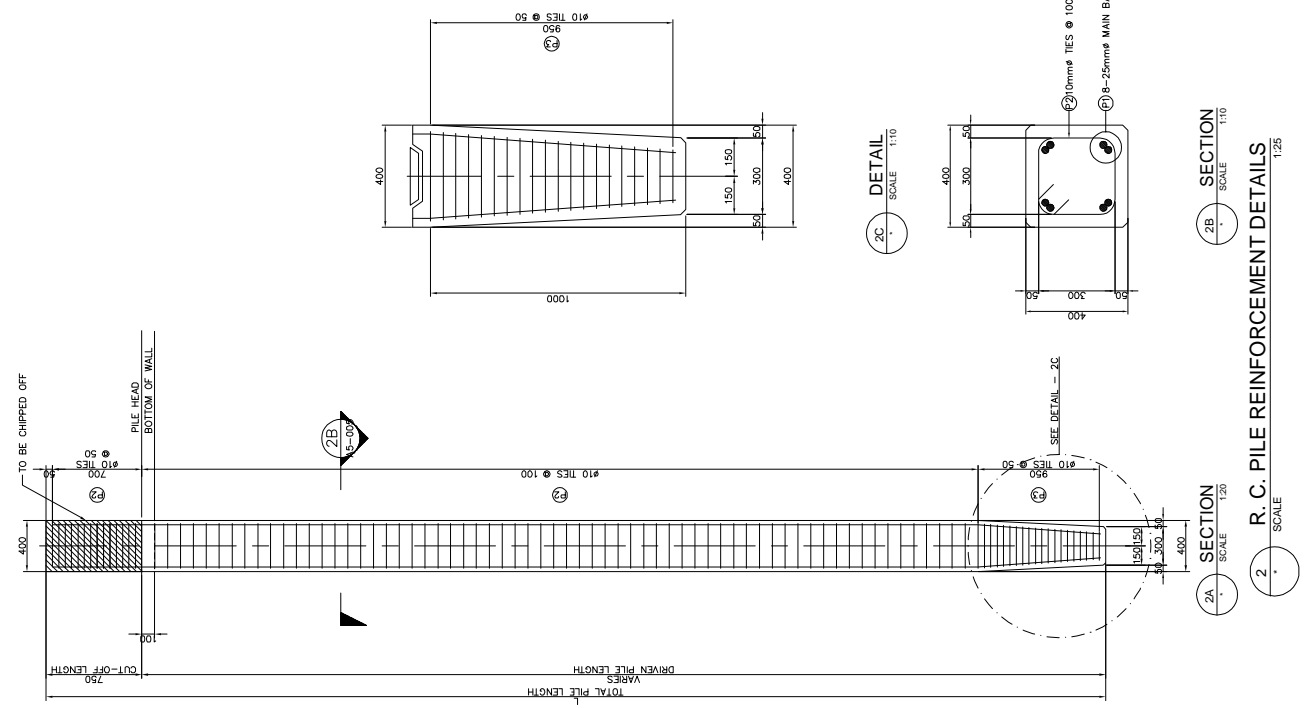

1 R. C. PILE LAYOUT AND DIMENSION SCALE 1:25

2 R. C. PILE REINFORCEMENT DETAILS SCALE 1:25

MINISTRY OF PUBLIC WORKS AND TRANSPORT (MPWT)	THE PROJECT FOR FLOOD DISASTER REHABILITATION AND MITIGATION IN THE KINGDOM OF CAMBODIA	JAPAN INTERNATIONAL COOPERATION AGENCY KATAHIRA & ENGINEERS INTERNATIONAL	STANDARD DRAWINGS RC PILE DETAILS	SCALE AS SHOWN	Drawing No. 9-3	Sheet No.
-----------------------------------------------	-----------------------------------------------------------------------------------------	---------------------------------------------------------------------------	-----------------------------------	----------------	-----------------	-----------

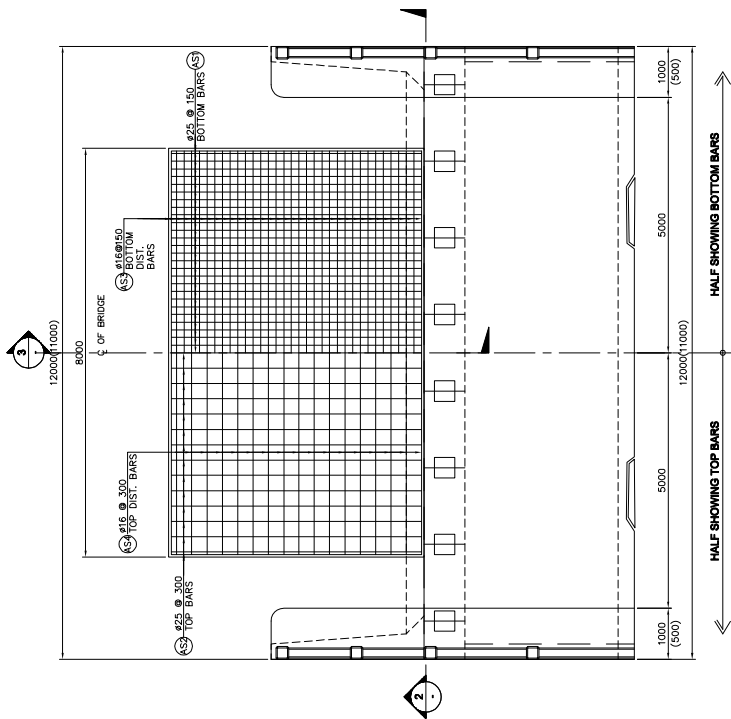

1 PLAN SCALE 1:100

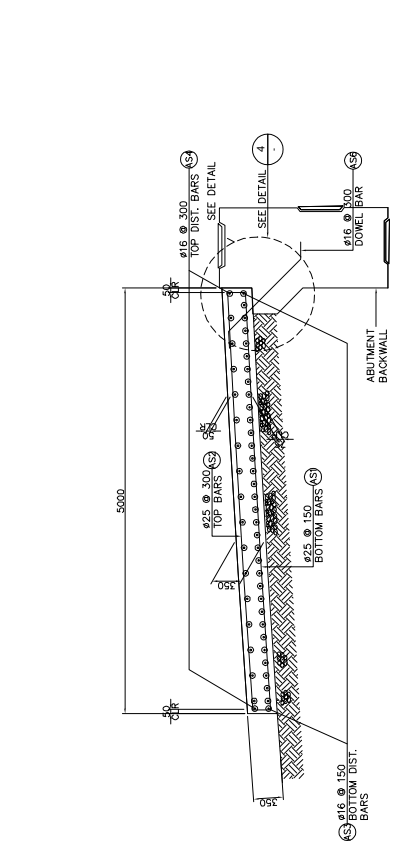

3 SECTION SCALE 1:80

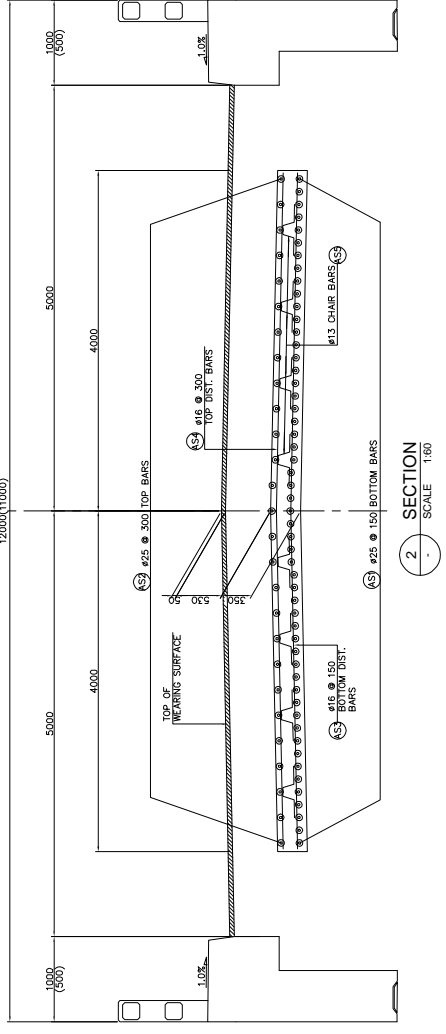

2 SECTION SCALE 1:80

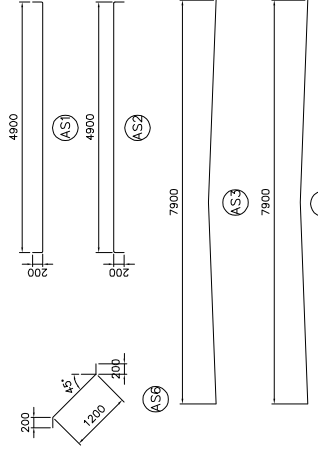

5 BAR BENDING DIAGRAM SCALE NOT TO

QUANTITY PER APPROACH SLAB					
BAR MARK	BAR SIZE	BAR LENGTH	QTY.	UNIT WT. PER BAR	TOTAL WT.
AS1	25	5,300	53	3,853	20,421
AS2	25	5,300	27	3,853	20,421
AS3	16	7,800	34	1,578	12,466
AS4	16	7,800	18	1,578	12,466
AS5	13	0,625	32	1,042	0,651
AS6	16	1,600	27	1,578	2,525
				TOTAL	2,370.92 Kgp
CONCRETE VOLUME CLASS A = 14.00 CU. M.					

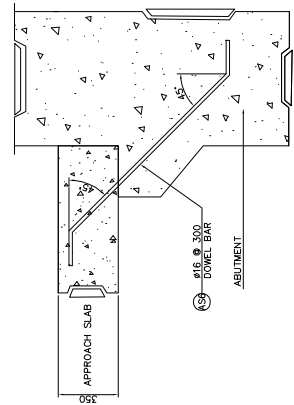

4 DETAIL SCALE 1:30

MINISTRY OF PUBLIC WORKS AND TRANSPORT (MPWT)

THE PROJECT FOR FLOOD DISASTER REHABILITATION AND MITIGATION IN THE KINGDOM OF CAMBODIA

JAPAN INTERNATIONAL COOPERATION AGENCY KATAHIRA & ENGINEERS INTERNATIONAL

TITLE: STANDARD DRAWINGS TYPICAL APPROACH SLAB DETAILS

SCALE AS SHOWN

Drawing No. 9-4 Sheet No.

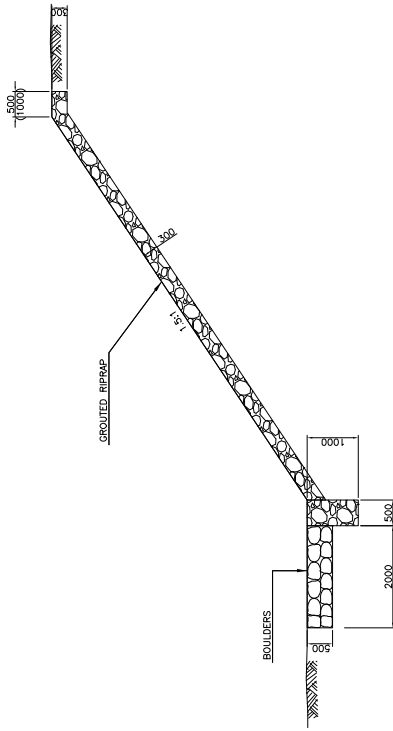

1 GROUTED RIPRAP SLOPE PROTECTION
SCALE 1:100

NOTE:
THE MINIMUM SIZE OF BOULDERS
SHALL BE LARGER THAN 200MM.
GEOTEXTILE SHALL BE INSTALLED
BENEATH THE BOULDERS.

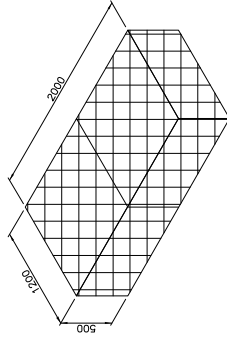

5 GABION MATTRESS
SCALE NOT TO SCALE

NOTE:
THE MINIMUM SIZE OF BOULDERS TO BE CONTAINED IN THE GABION SHALL BE
LARGER THAN 200mm.
THE WIRE MESH SHALL BE MADE OF GALVANIZED STEEL HAVING MINIMUM SIZE
OF 3.2MM (3/16 INCH) DIAMETER (U.S. WIRE GAGE NO. 11). THE TENSILE
STRENGTH OF THE WIRE SHALL BE IN THE RANGE OF 413.7 TO 586.1 MPa
(60,000 TO 85,000 PSI). THE MINIMUM ZINC COATING OF THE WIRE SHALL BE
AS PER ASTM A641. THE MINIMUM ZINC COATING OF THE WIRE SHALL BE
DETERMINED BY TESTS CONDUCTED IN ACCORDANCE WITH AASHTO T 85.

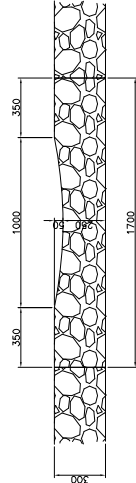

2A SECTION
SCALE 1:30

2 SIDE DRAIN IN GROUTED RIPRAP
SCALE AS SHOWN

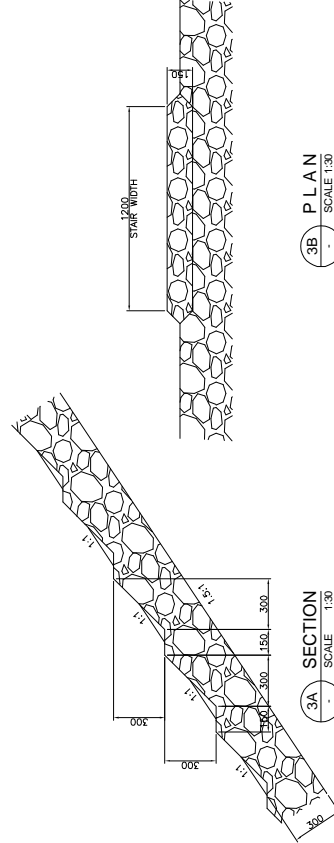

3A SECTION
SCALE 1:30

3B PLAN
SCALE 1:30

3 STAIRS IN GROUTED RIPRAP
SCALE AS SHOWN

QUANTITY PER GUIDE POST	
CONCRETE CLASS * C *	0.038 m ³
BAR # 10	3.95 kg
BAR # 8	1.2 kg

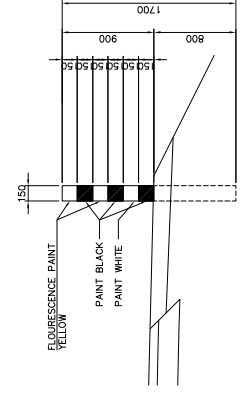

4A ELEVATION
SCALE 1:50

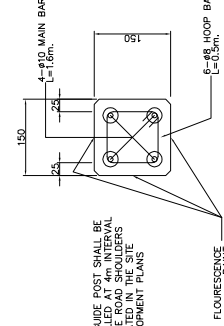

4B SECTION
SCALE 1:10

NOTE: THE GUIDE POST SHALL BE
AS SHOWN AND BOULDERS
INDICATED IN THE SITE
DEVELOPMENT PLANS

4 GUIDE POST
SCALE AS SHOWN

MINISTRY OF PUBLIC WORKS AND TRANSPORT (MPWT)	THE PROJECT FOR FLOOD DISASTER REHABILITATION AND MITIGATION IN THE KINGDOM OF CAMBODIA	JAPAN INTERNATIONAL COOPERATION AGENCY KATAHIRA & ENGINEERS INTERNATIONAL	TITLE : STANDARD DRAWINGS RIPRAP SLOPE PROTECTION, GABION MATTRESS AND GUIDE POST DETAILS	SCALE	AS SHOWN
				Drawing No.	9 - 5
					Sheet No.

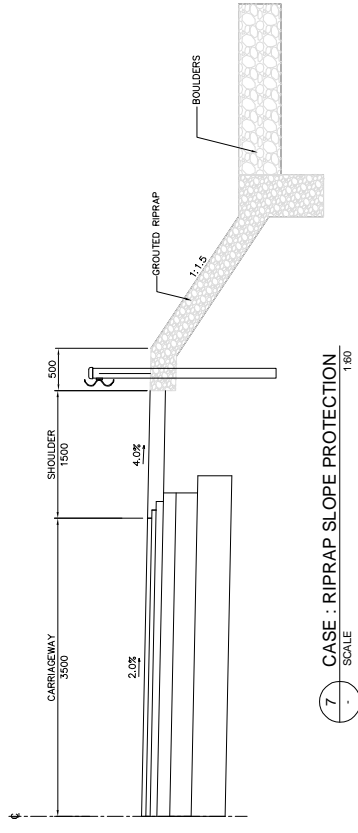
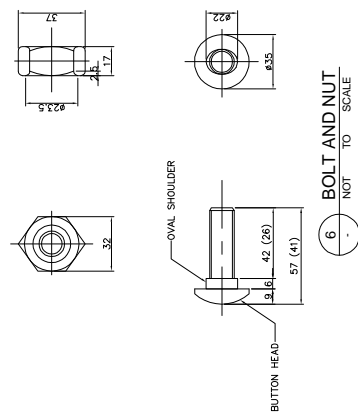
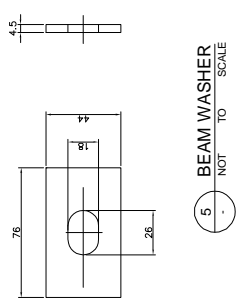
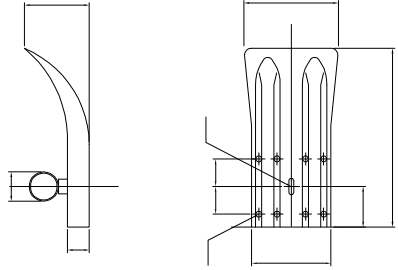
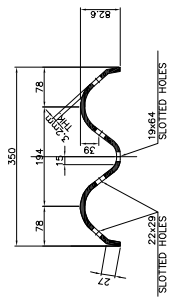
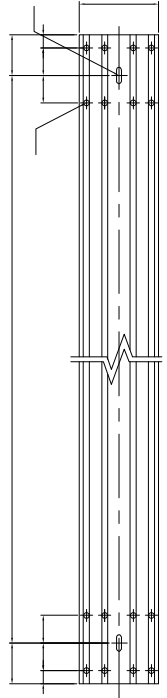
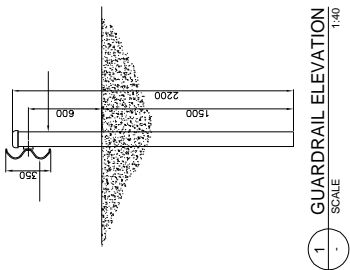

1. MATERIALS AND WORKMANSHIP FOR METAL BEAM GUARDRAIL SHALL COMPLY TO THE TECHNICAL SPECIFICATIONS OF THIS CONTRACT.
2. ALL DIMENSIONS ARE IN MILLIMETERS UNLESS OTHERWISE INDICATED.
3. ALL NUTS SHALL BE WELDED TO BOLTS AFTER TIGHTENING.
4. STRUCTURAL STEEL SHALL CONFORM TO THE REQUIREMENTS OF AASHTO M180
5. EXACT LOCATION OF GUARDRAILS SHALL BE VERIFIED ON SITE DURING CONSTRUCTION.
6. GUARDRAIL PRODUCTS SIMILAR AND EQUIVALENT TO THIS DRAWING MAY BE ACCEPTED WHEN APPROVED BY THE CONSULTANT.

MINISTRY OF PUBLIC WORKS AND TRANSPORT (MPWT)	THE PROJECT FOR FLOOD DISASTER REHABILITATION AND MITIGATION IN THE KINGDOM OF CAMBODIA	JAPAN INTERNATIONAL COOPERATION AGENCY KATAHIRA & ENGINEERS INTERNATIONAL	TITLE: STANDARD DRAWING STEEL BEAM GUARDRAIL DETAILS	SCALE	Drawing No.
				AS SHOWN	9-7
					Sheet No.

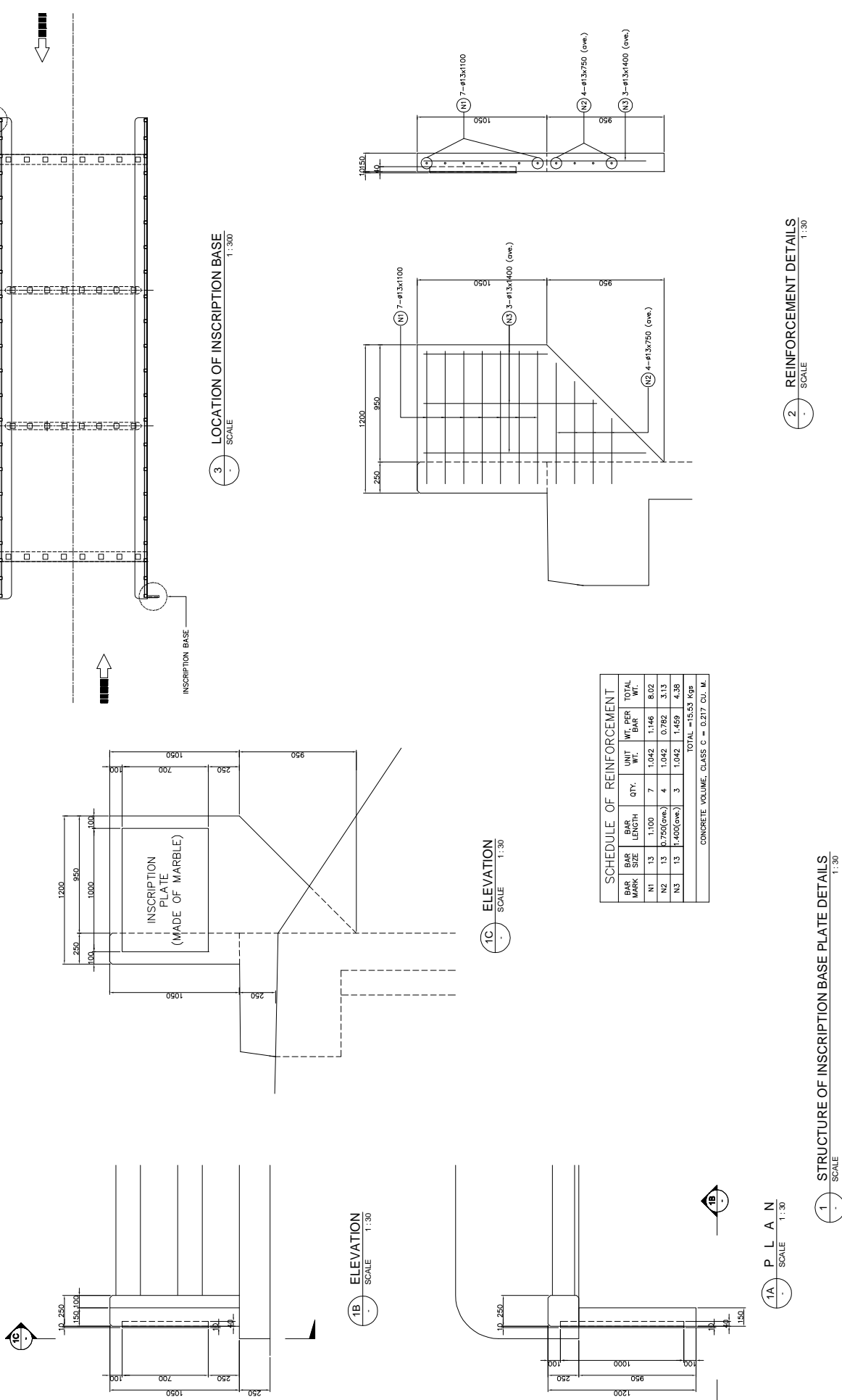

MINISTRY OF PUBLIC WORKS AND TRANSPORT (MPWT)	THE PROJECT FOR FLOOD DISASTER REHABILITATION AND MITIGATION IN THE KINGDOM OF CAMBODIA	JAPAN INTERNATIONAL COOPERATION AGENCY KATAHIRA & ENGINEERS INTERNATIONAL	TITLE:	STANDARD DRAWINGS INSCRIPTION BASE DETAILS	SCALE:	AS SHOWN	Drawing No.:	9 - 8
							Sheet No.:	