

3. *Hydrogeology*

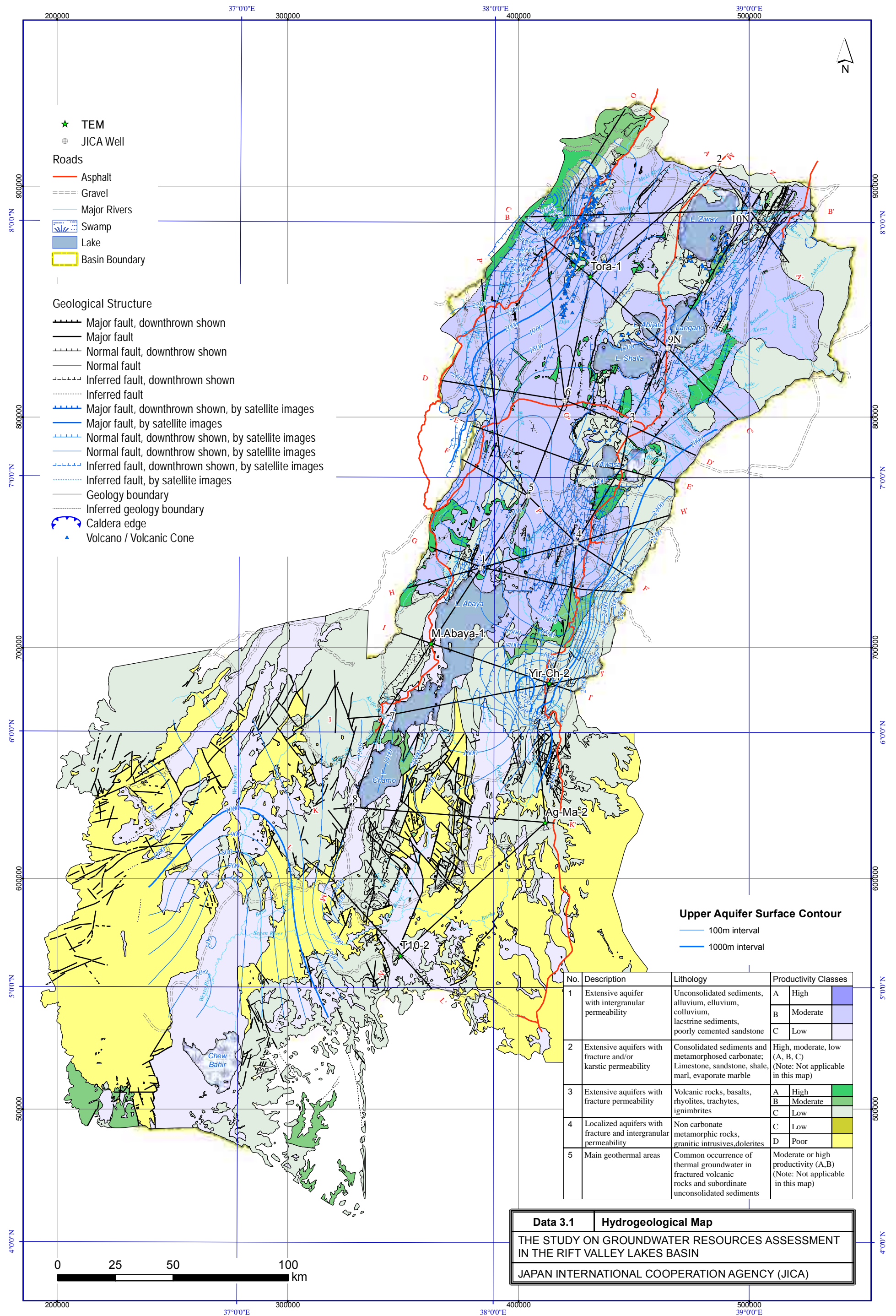

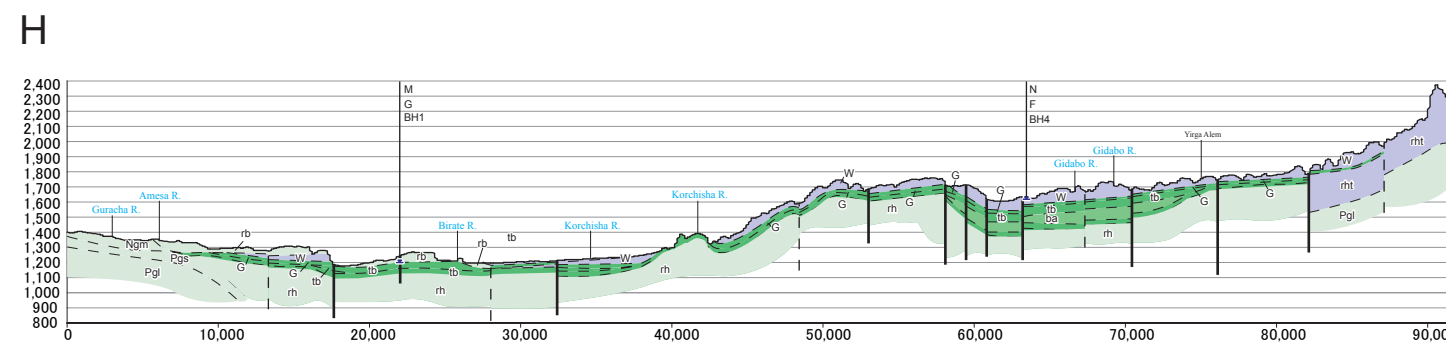

No.	Description	Lithology	Productivity Classes
1	Extensive aquifer with intergranular permeability	Unconsolidated sediments, alluvium, elluvium, colluvium, lacstrine sediments, poorly cemented sandstone	A High B Moderate C Low
2	Extensive aquifers with fracture and/or karstic permeability	Consolidated sediments and metamorphosed carbonate; Limestone, sandstone, shale, marl, evaporate marl	High, moderate, low (A, B, C) (Note: Not applicable in this map)
3	Extensive aquifers with fracture permeability	Volcanic rocks, basalts, rhyolites, trachytes, ignimbrites	A High B Moderate C Low
4	Localized aquifers with fracture and intergranular permeability	Non carbonate metamorphic rocks, granitic intrusives, dolerites	C Low D Poor
5	Main geothermal areas	Common occurrence of thermal groundwater in fractured volcanic rocks and subordinate unconsolidated sediments	Moderate or high productivity (A,B) (Note: Not applicable in this map)

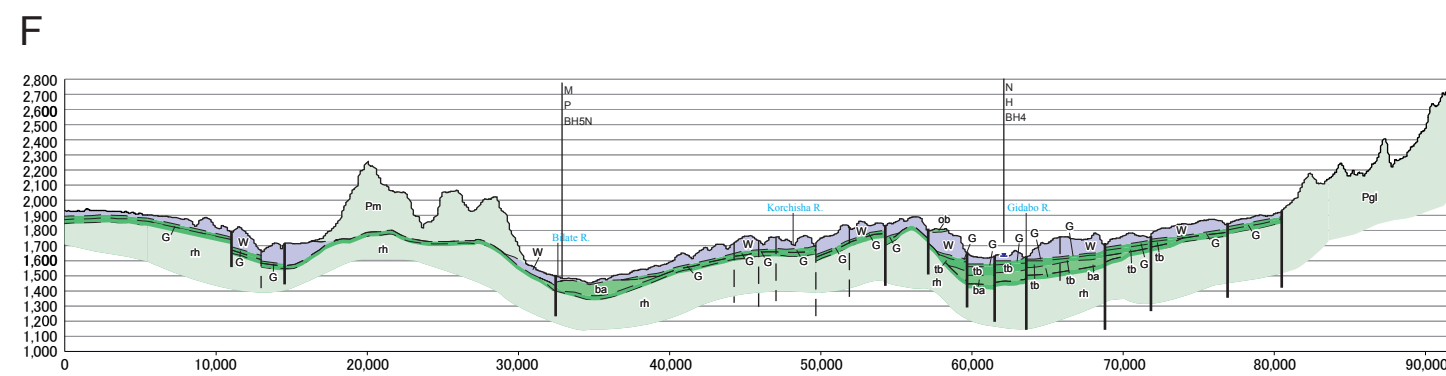
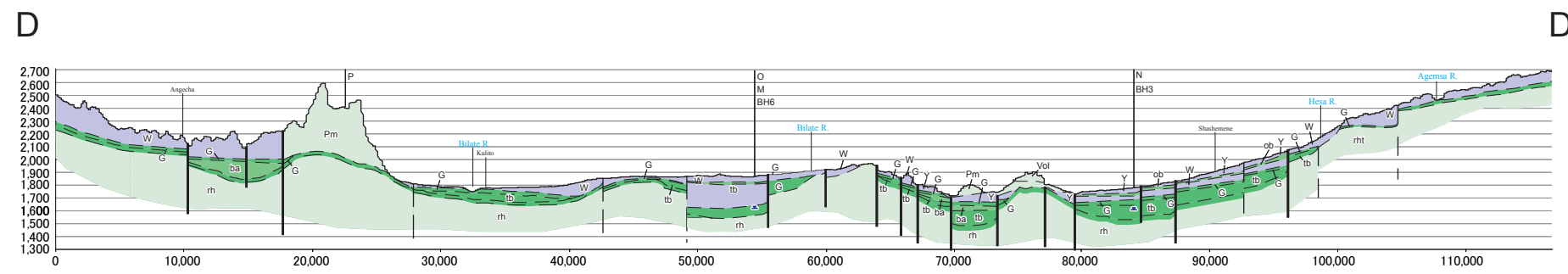
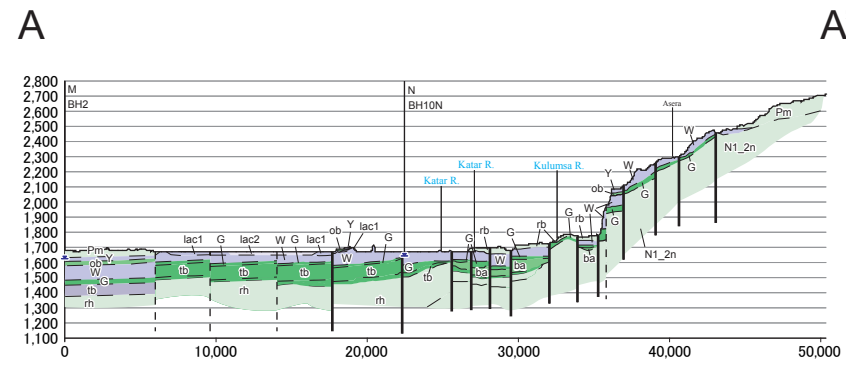
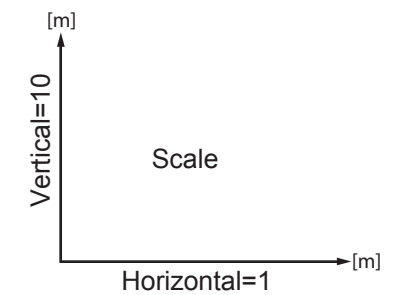

Data 3.2 Hydrogeological Cross Section (1/6)
**THE STUDY ON GROUNDWATER RESOURCES ASSESSMENT
IN THE RIFT VALLEY LAKES BASIN**
JAPAN INTERNATIONAL COOPERATION AGENCY(JICA)

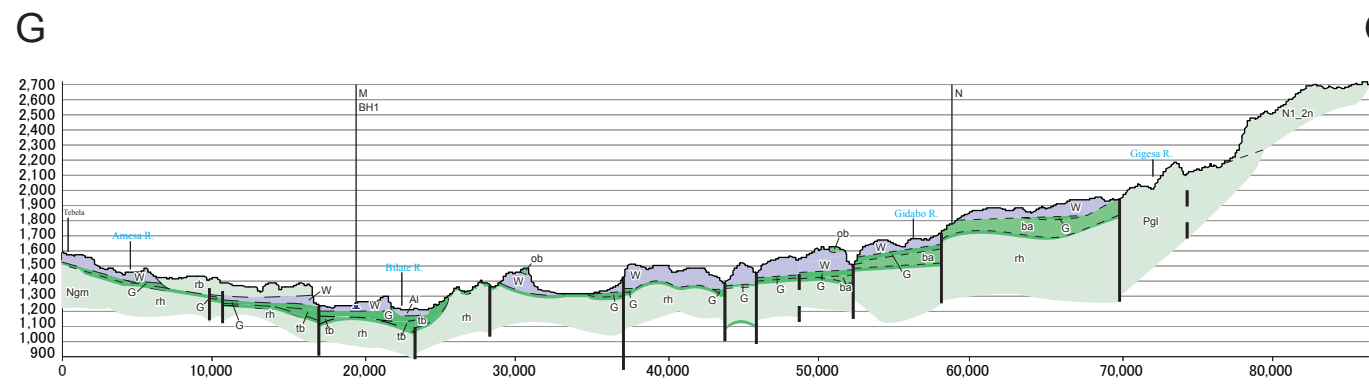
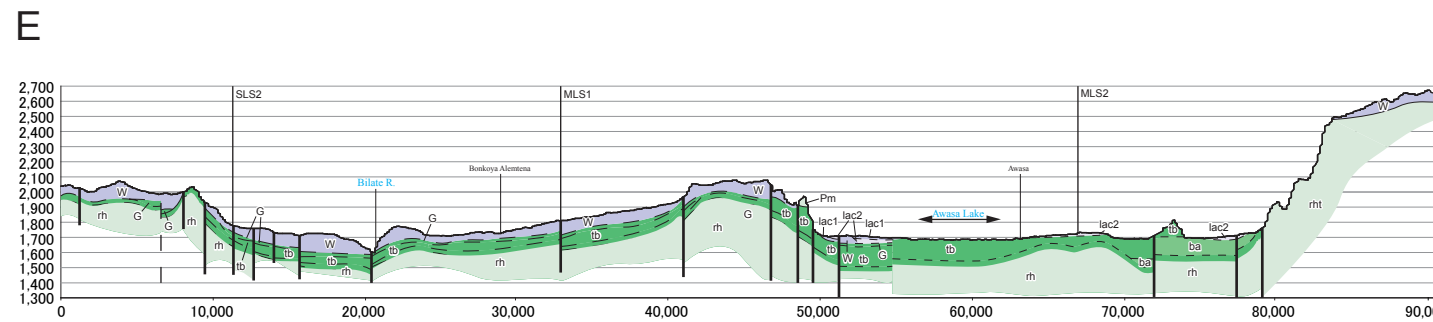
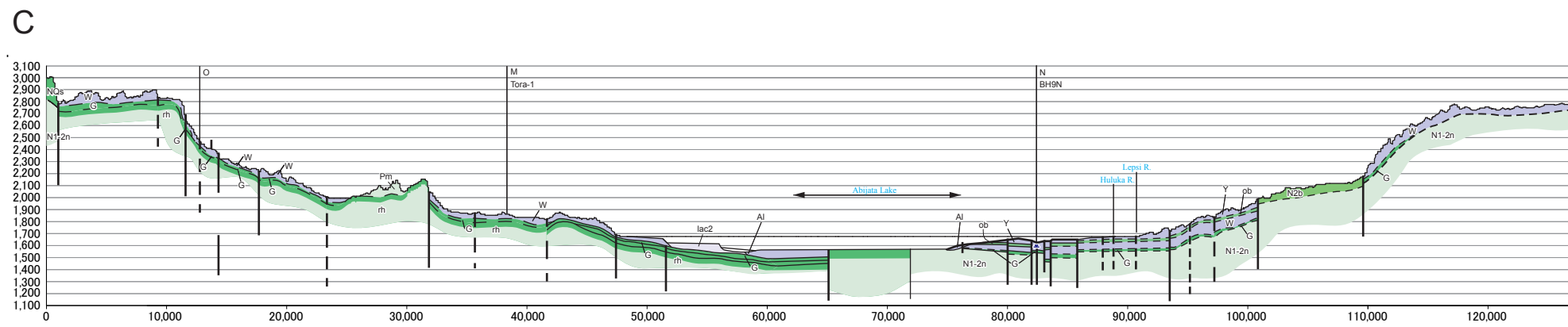
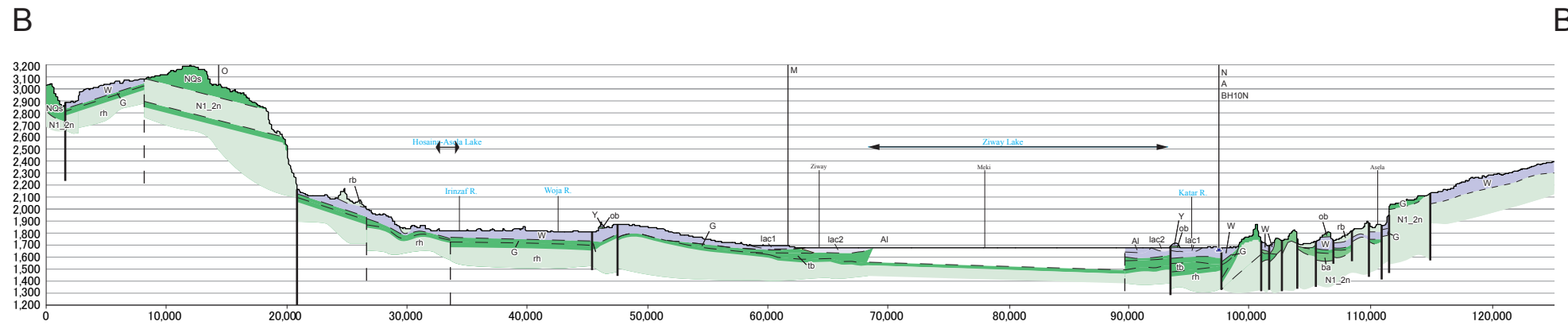

No.	Description	Lithology	Productivity Classes
1	Extensive aquifer with intergranular permeability	Unconsolidated sediments, alluvium, elluvium, colluvium, lacstrine sediments, poorly cemented sandstone	A High
			B Moderate
			C Low
2	Extensive aquifers with fracture and/or karstic permeability	Consolidated sediments and metamorphosed carbonate; Limestone, sandstone, shale, marl, evaporate marble	High, moderate, low (A, B, C) (Note: Not applicable in this map)
3	Extensive aquifers with fracture permeability	Volcanic rocks, basalts, rhyolites, trachytes, ignimbrites	A High
			B Moderate
			C Low
4	Localized aquifers with fracture and intergranular permeability	Non carbonate metamorphic rocks, granitic intrusives, dolerites	C Low
			D Poor
5	Main geothermal areas	Common occurrence of thermal groundwater in fractured volcanic rocks and subordinate unconsolidated sediments	Moderate or high productivity (A,B) (Note: Not applicable in this map)

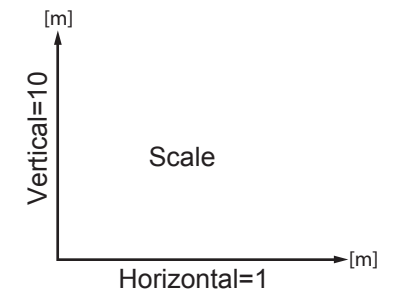

Data 3.2 Hydrogeological Cross Section (2/6)
**THE STUDY ON GROUNDWATER RESOURCES ASSESSMENT
IN THE RIFT VALLEY LAKES BASIN**
JAPAN INTERNATIONAL COOPERATION AGENCY(JICA)

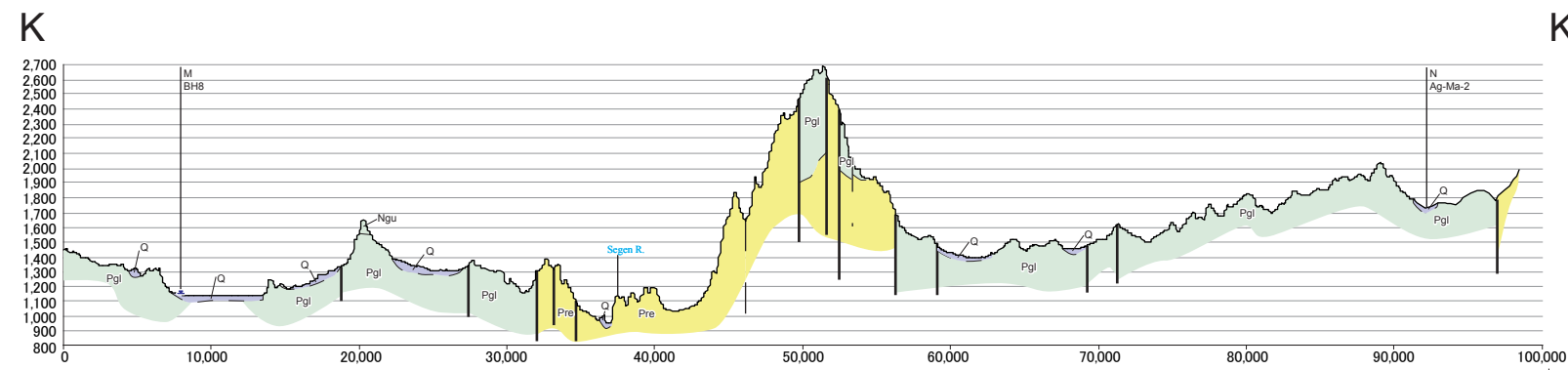
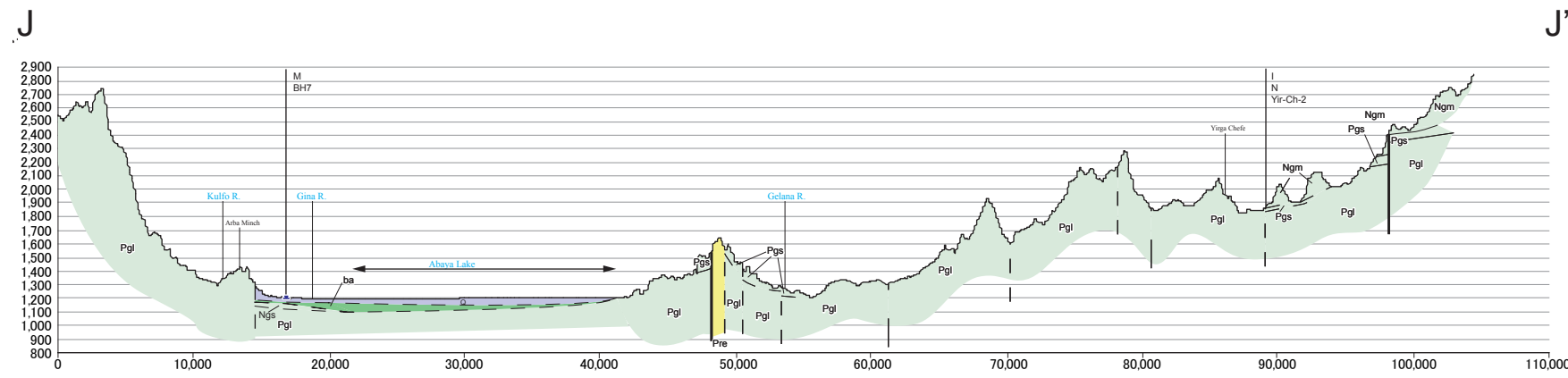
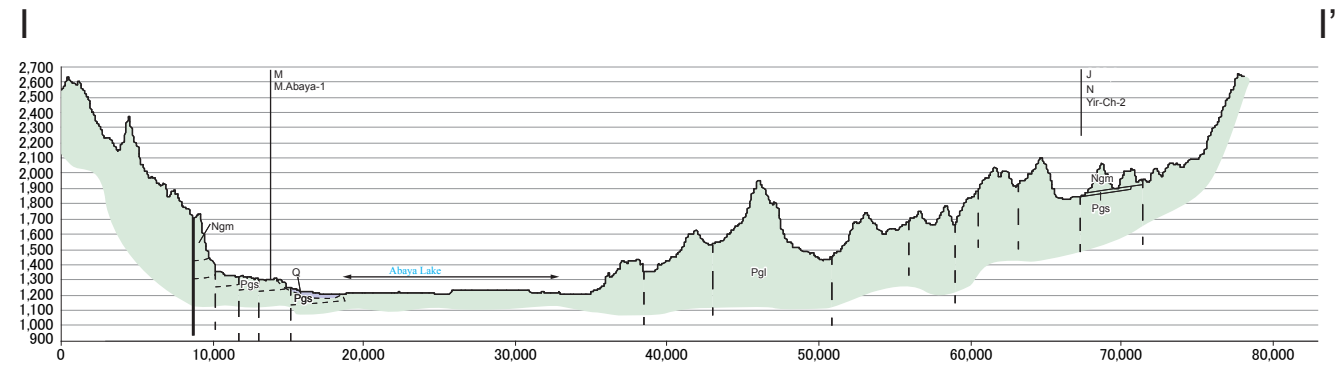

No.	Description	Lithology	Productivity Classes
1	Extensive aquifer with intergranular permeability	Unconsolidated sediments, alluvium, elluvium, colluvium, lacstrine sediments, poorly cemented sandstone	A High
			B Moderate
			C Low
2	Extensive aquifers with fracture and/or karstic permeability	Consolidated sediments and metamorphosed carbonate; Limestone, sandstone, shale, marl, evaporate marble	High, moderate, low (A, B, C) (Note: Not applicable in this map)
3	Extensive aquifers with fracture permeability	Volcanic rocks, basalts, rhyolites, trachytes, ignimbrites	A High
			B Moderate
			C Low
4	Localized aquifers with fracture and intergranular permeability	Non carbonate metamorphic rocks, granitic intrusives, dolerites	C Low
			D Poor
5	Main geothermal areas	Common occurrence of thermal groundwater in fractured volcanic rocks and subordinate unconsolidated sediments	Moderate or high productivity (A,B) (Note: Not applicable in this map)

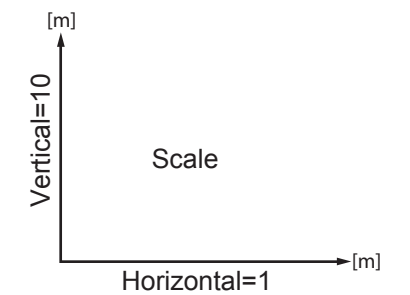

Data 3.2 Hydrogeological Cross Section (3/6)
**THE STUDY ON GROUNDWATER RESOURCES ASSESSMENT
IN THE RIFT VALLEY LAKES BASIN**
JAPAN INTERNATIONAL COOPERATION AGENCY(JICA)

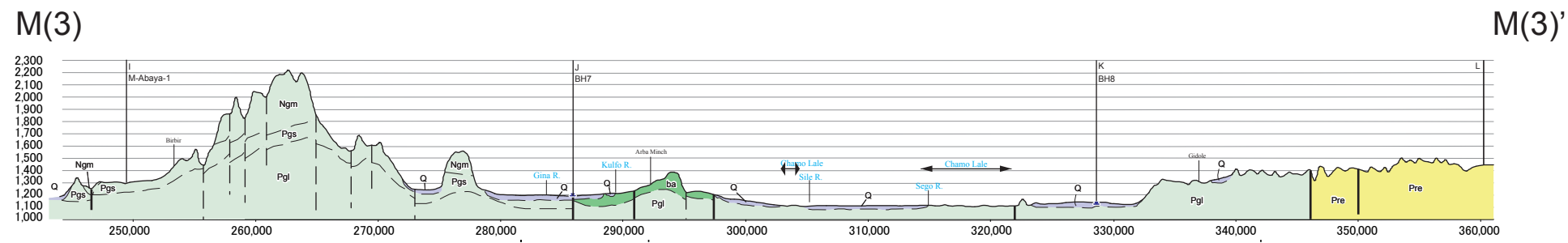
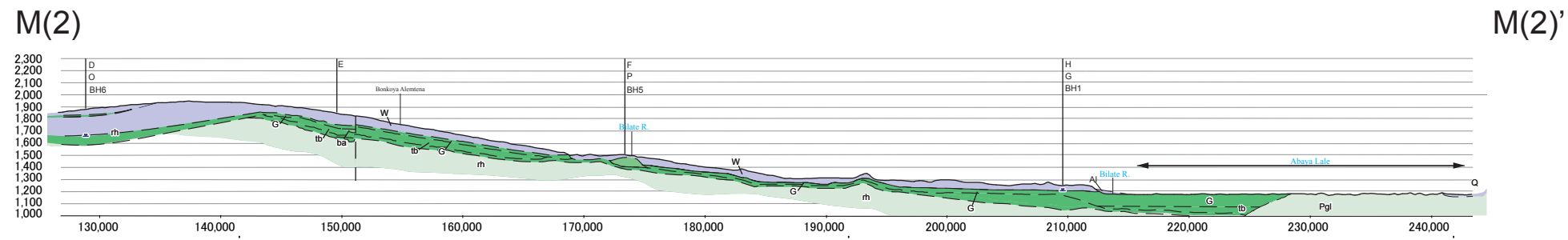
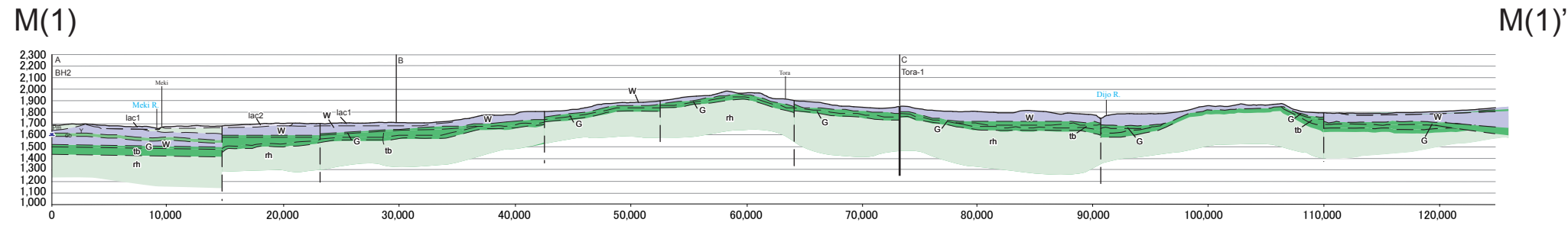

No.	Description	Lithology	Productivity Classes
1	Extensive aquifer with intergranular permeability	Unconsolidated sediments, alluvium, elluvium, colluvium, lacstrine sediments, poorly cemented sandstone	A High
			B Moderate
			C Low
2	Extensive aquifers with fracture and/or karstic permeability	Consolidated sediments and metamorphosed carbonate; Limestone, sandstone, shale, marl, evaporate marble	High, moderate, low (A, B, C) (Note: Not applicable in this map)
3	Extensive aquifers with fracture permeability	Volcanic rocks, basalts, rhyolites, trachytes, ignimbrites	A High
			B Moderate
			C Low
4	Localized aquifers with fracture and intergranular permeability	Non carbonate metamorphic rocks, granitic intrusives, dolerites	C Low
			D Poor
5	Main geothermal areas	Common occurrence of thermal groundwater in fractured volcanic rocks and subordinate unconsolidated sediments	Moderate or high productivity (A,B) (Note: Not applicable in this map)

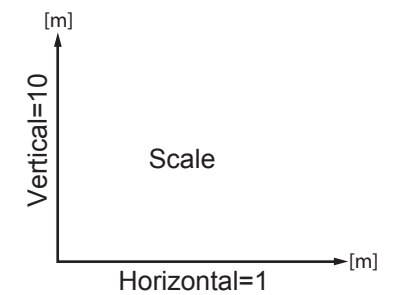

Data 3.2 Hydrogeological Cross Section (4/6)
**THE STUDY ON GROUNDWATER RESOURCES ASSESSMENT
IN THE RIFT VALLEY LAKES BASIN**
JAPAN INTERNATIONAL COOPERATION AGENCY(JICA)

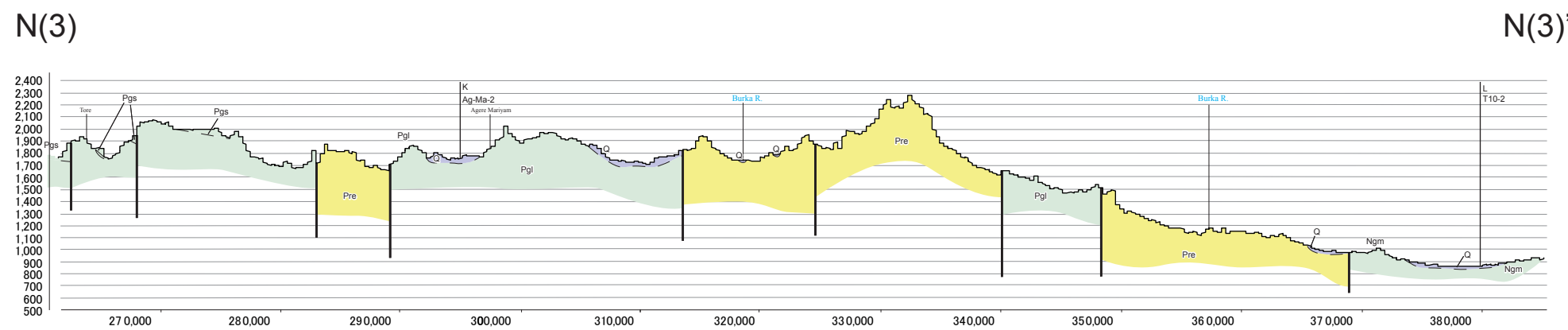
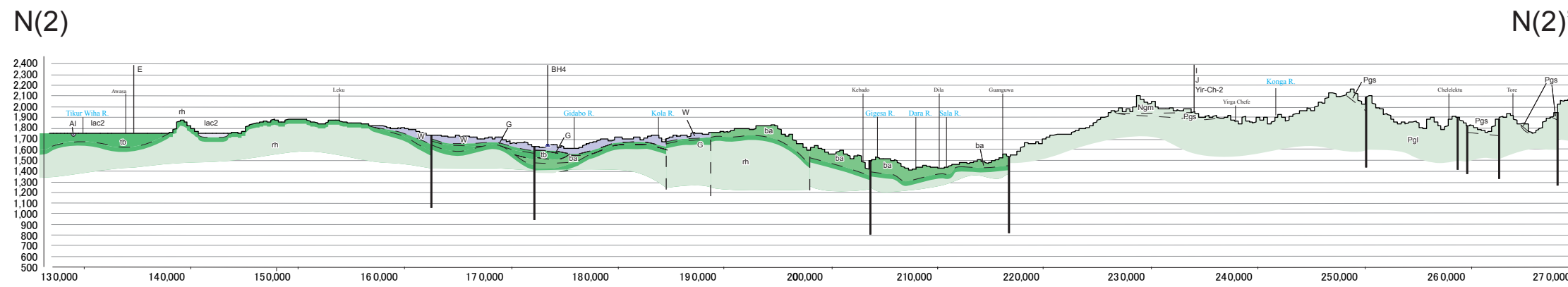
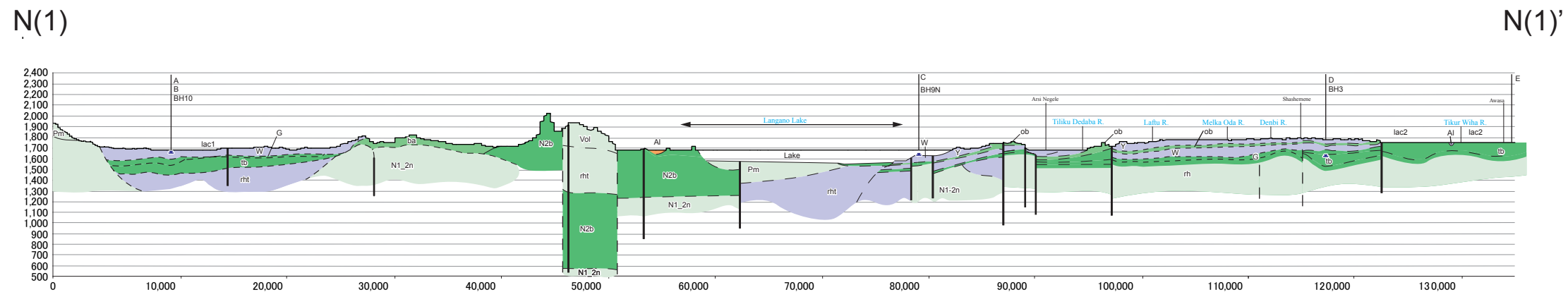

No.	Description	Lithology	Productivity Classes
1	Extensive aquifer with intergranular permeability	Unconsolidated sediments, alluvium, elluvium, colluvium, lacstrine sediments, poorly cemented sandstone	A High
			B Moderate
			C Low
2	Extensive aquifers with fracture and/or karstic permeability	Consolidated sediments and metamorphosed carbonate; Limestone, sandstone, shale, marl, evaporate marble	High, moderate, low (A, B, C) (Note: Not applicable in this map)
3	Extensive aquifers with fracture permeability	Volcanic rocks, basalts, rhyolites, trachytes, ignimbrites	A High
			B Moderate
			C Low
4	Localized aquifers with fracture and intergranular permeability	Non carbonate metamorphic rocks, granitic intrusives, dolerites	C Low
			D Poor
	Main geothermal areas	Common occurrence of thermal groundwater in fractured volcanic rocks and subordinate unconsolidated sediments	Moderate or high productivity (A,B) (Note: Not applicable in this map)

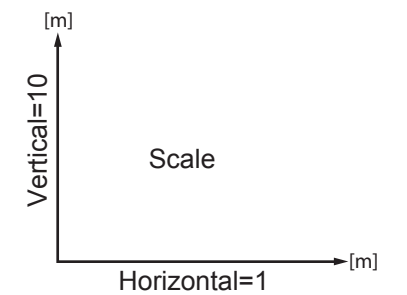

Data 3.2 Hydrogeological Cross Section (5/6)
**THE STUDY ON GROUNDWATER RESOURCES ASSESSMENT
IN THE RIFT VALLEY LAKES BASIN**
JAPAN INTERNATIONAL COOPERATION AGENCY(JICA)

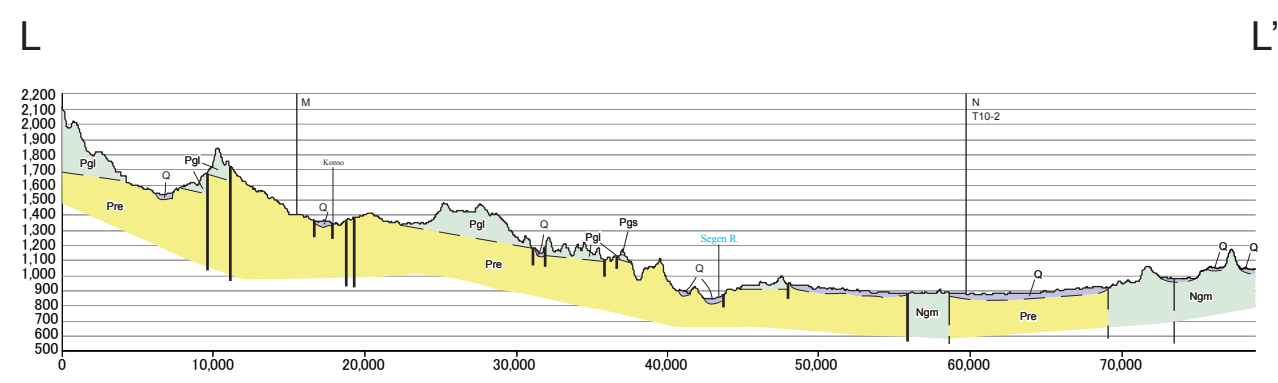
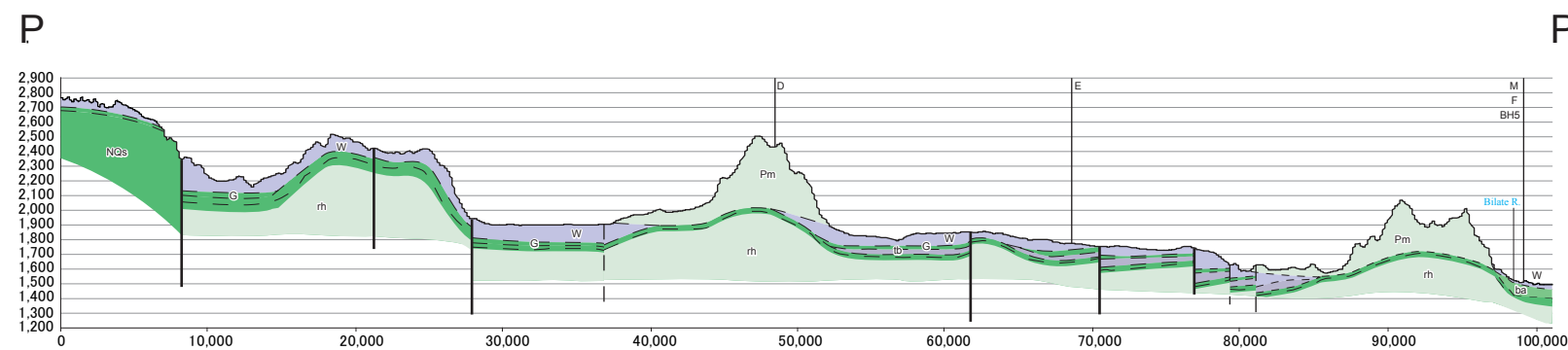
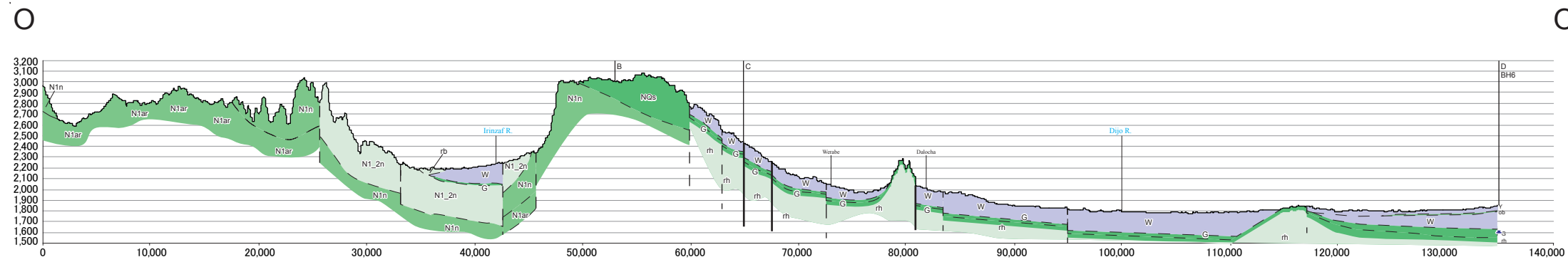

No.	Description	Lithology	Productivity Classes
1	Extensive aquifer with intergranular permeability	Unconsolidated sediments, alluvium, elluvium, colluvium, lacstrine sediments, poorly cemented sandstone	A High
			B Moderate
			C Low
2	Extensive aquifers with fracture and/or karstic permeability	Consolidated sediments and metamorphosed carbonate; Limestone, sandstone, shale, marl, evaporate marble	High, moderate, low (A, B, C) (Note: Not applicable in this map)
3	Extensive aquifers with fracture permeability	Volcanic rocks, basalts, rhyolites, trachytes, ignimbrites	A High
			B Moderate
			C Low
4	Localized aquifers with fracture and intergranular permeability	Non carbonate metamorphic rocks, granitic intrusives, dolerites	C Low
			D Poor
5	Main geothermal areas	Common occurrence of thermal groundwater in fractured volcanic rocks and subordinate unconsolidated sediments	Moderate or high productivity (A,B) (Note: Not applicable in this map)

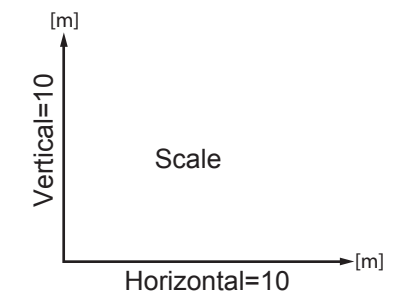

Data 3.2 Hydrogeological Cross Section (6/6)
**THE STUDY ON GROUNDWATER RESOURCES ASSESSMENT
IN THE RIFT VALLEY LAKES BASIN**
JAPAN INTERNATIONAL COOPERATION AGENCY(JICA)

Data 3.3 Hexa Diagram of Water Quality Samples (1/11)

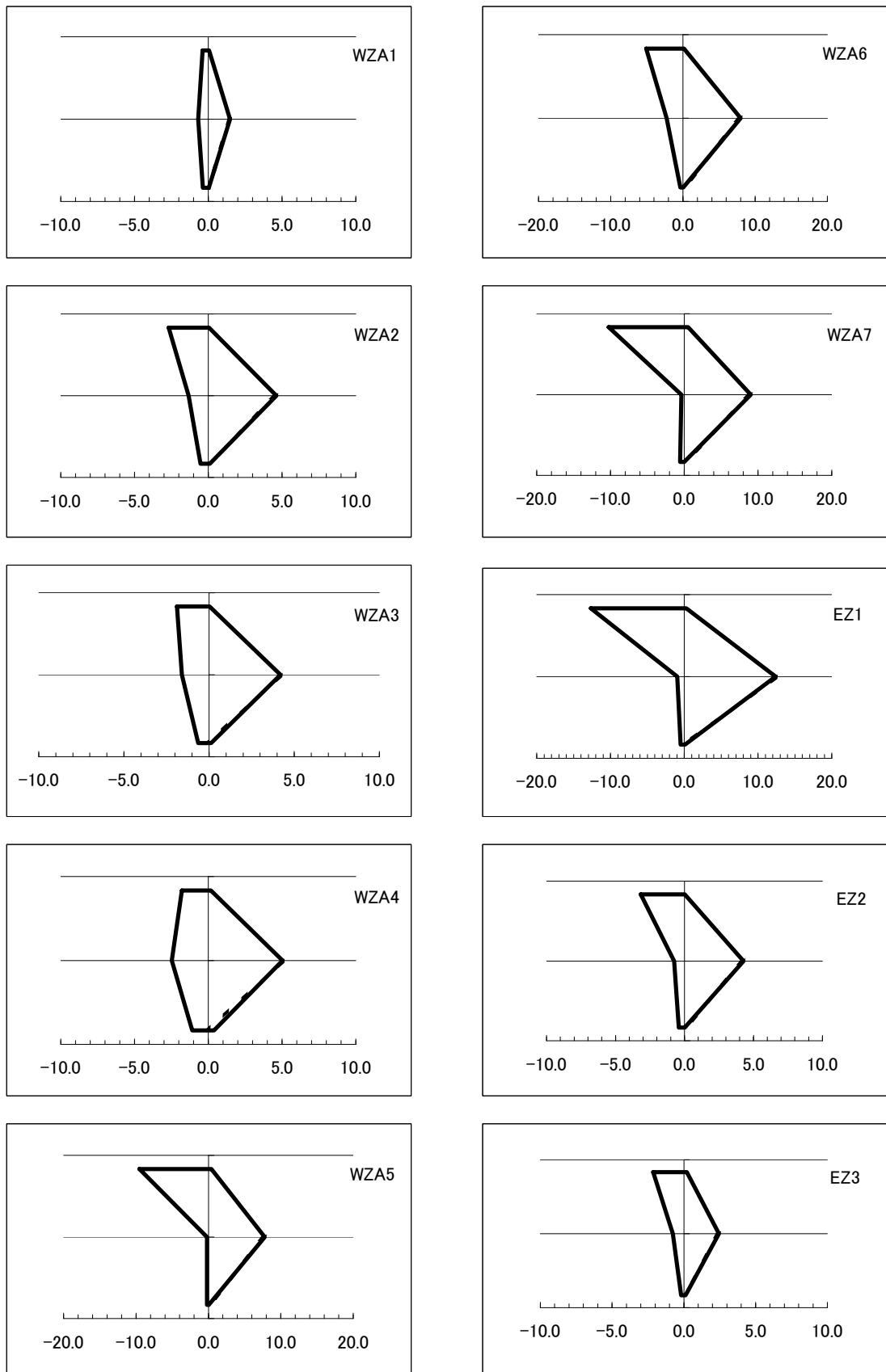

Data 3.3 Hexa Diagram of Water Quality Samples (2/11)

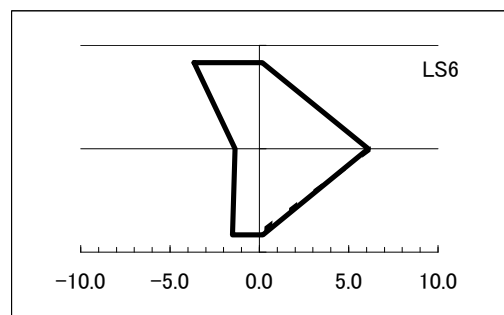
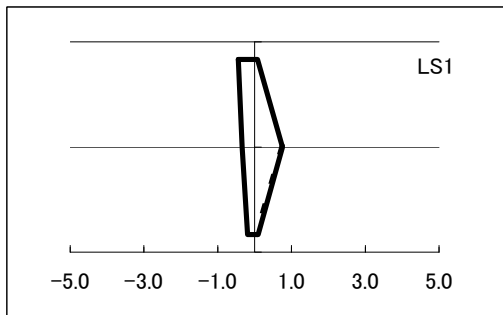
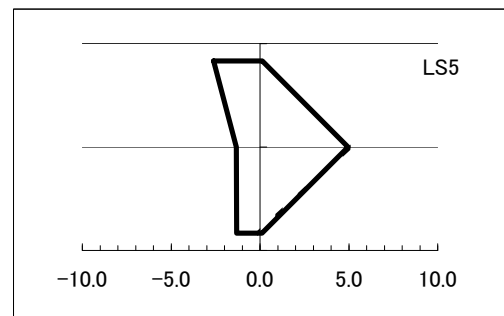
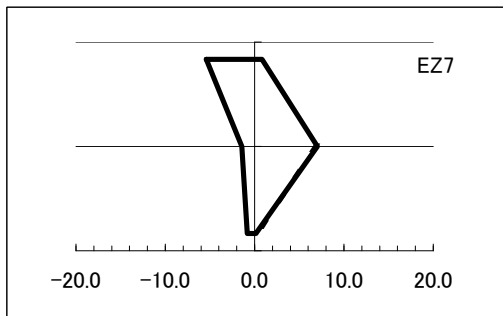
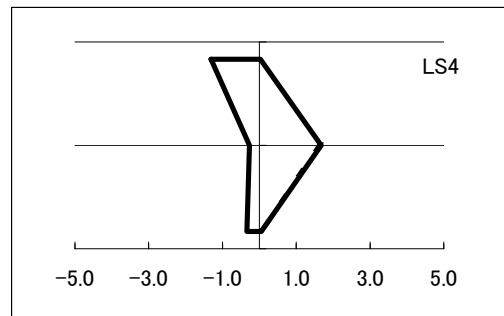
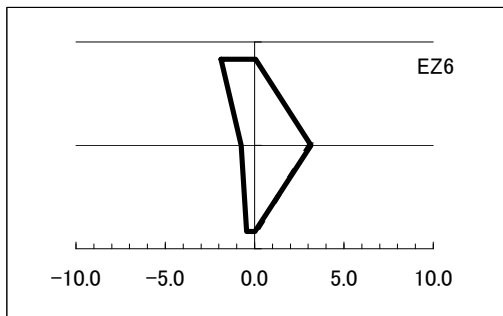
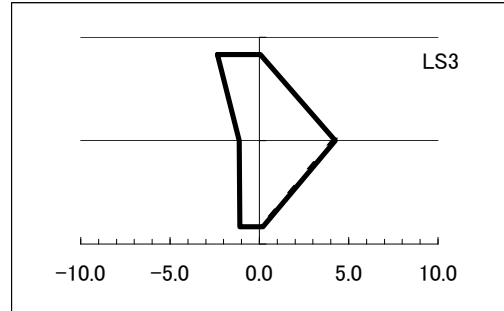
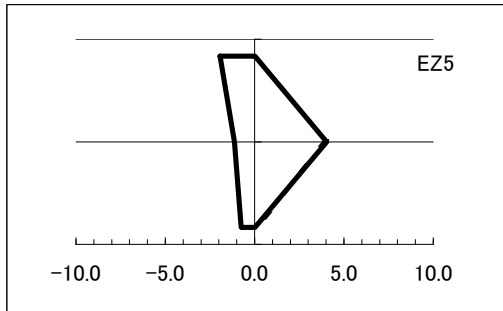
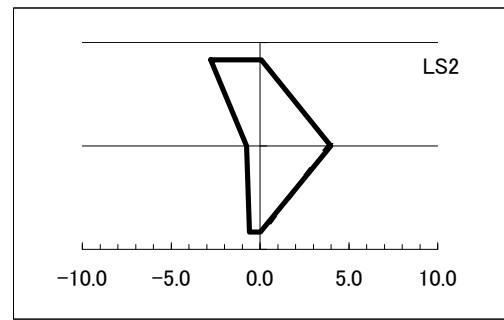
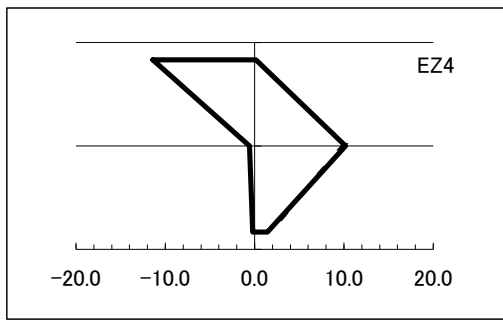

Data 3.3 Hexa Diagram of Water Quality Samples (3/11)

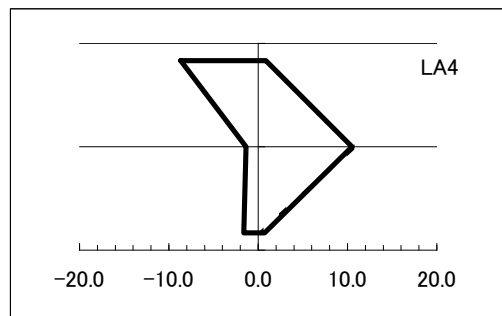
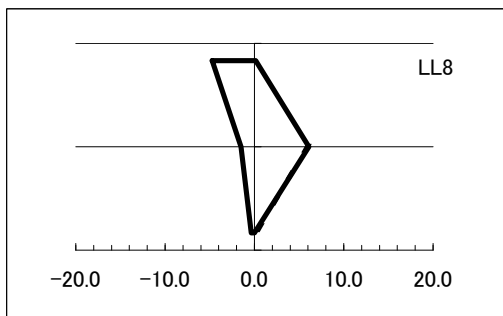
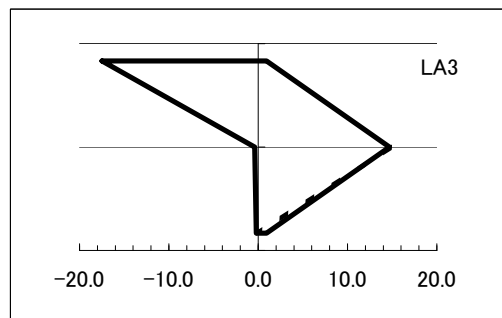
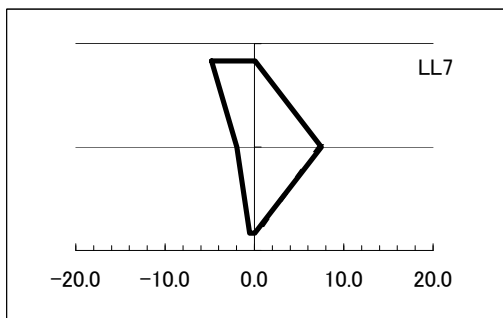
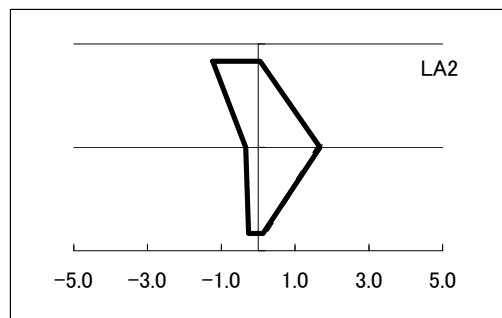
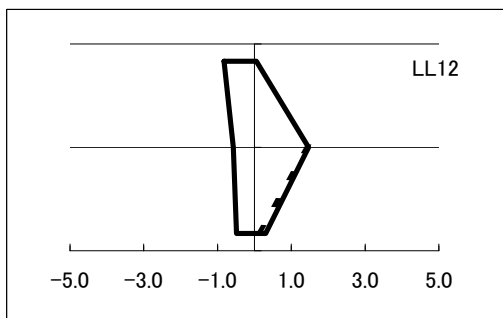
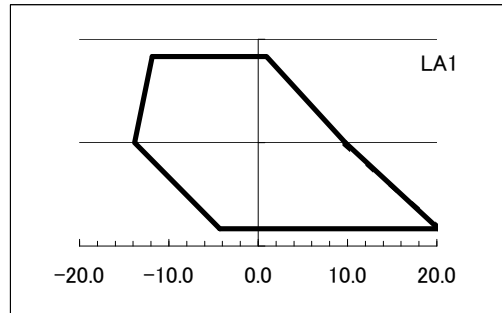
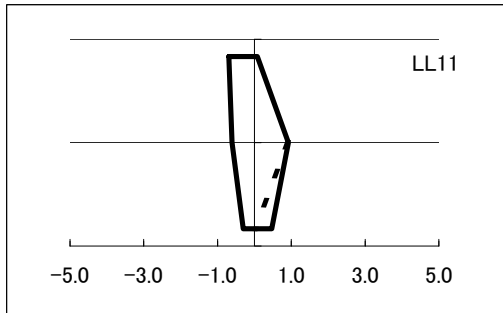
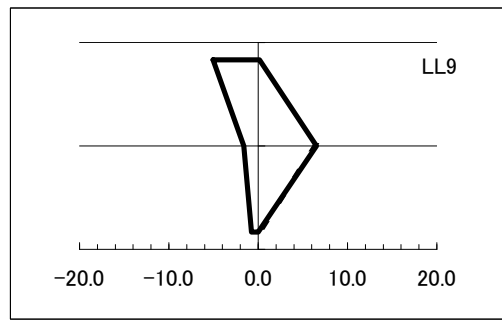
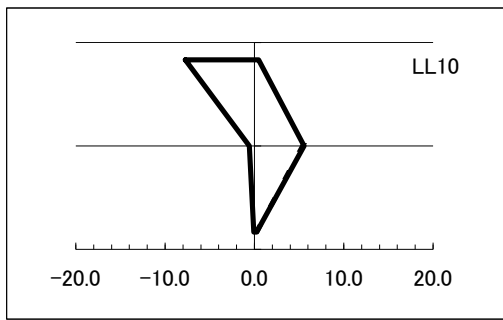

Data 3.3 Hexa Diagram of Water Quality Samples (4/11)

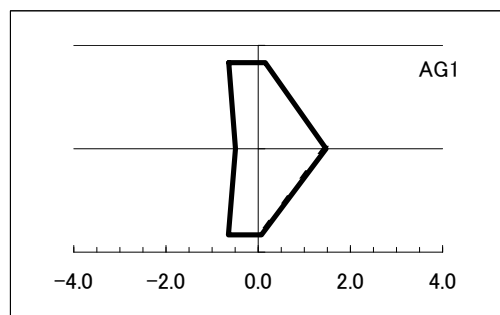
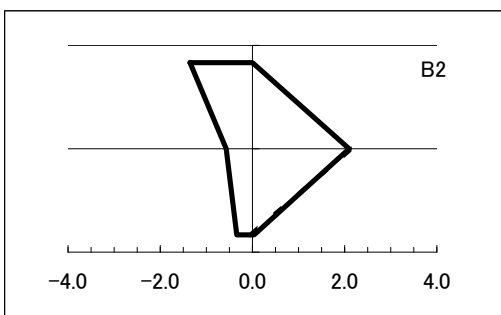
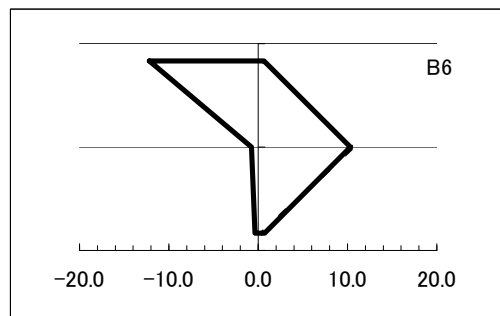
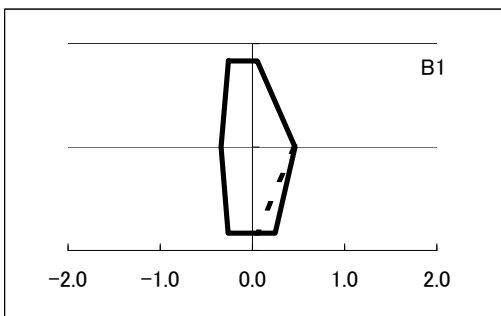
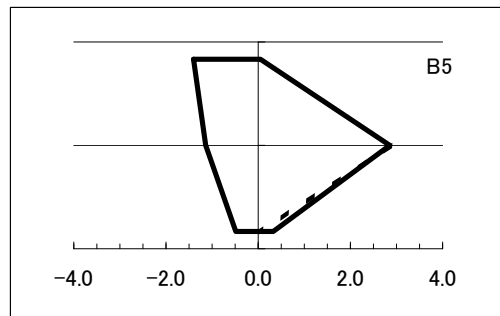
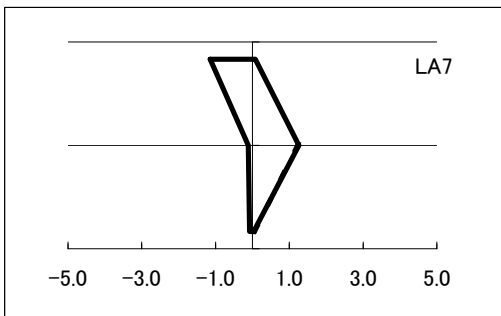
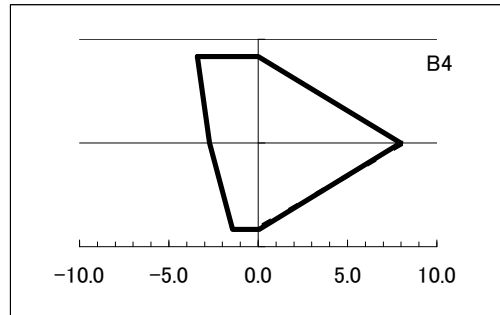
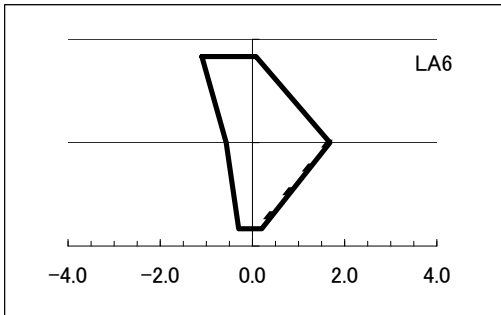
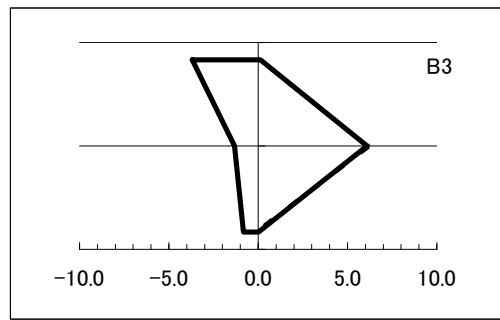
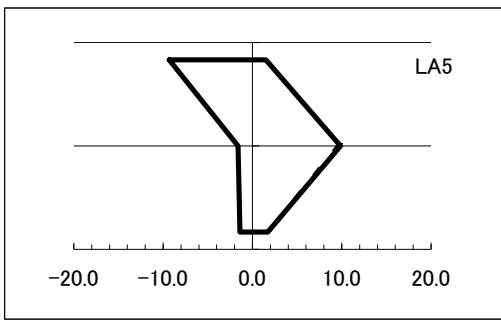

Data 3.3 Hexa Diagram of Water Quality Samples (5/11)

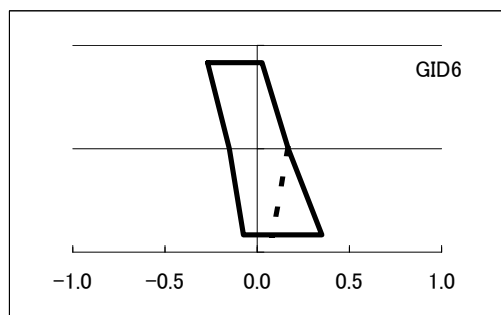
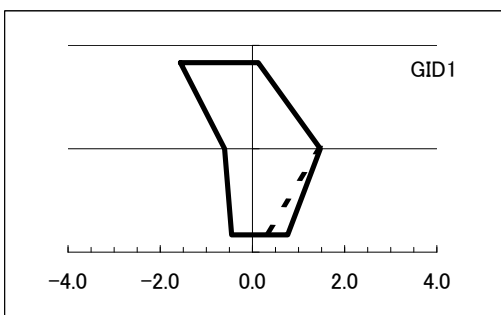
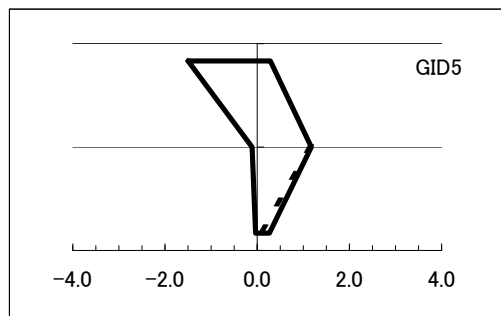
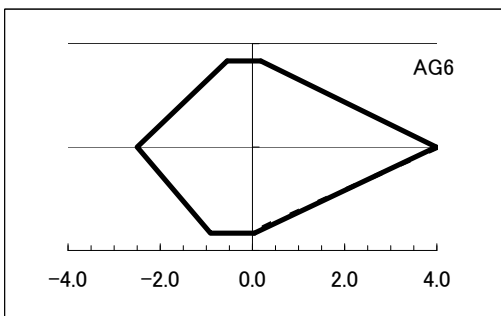
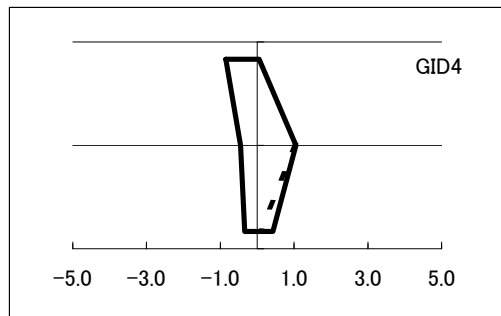
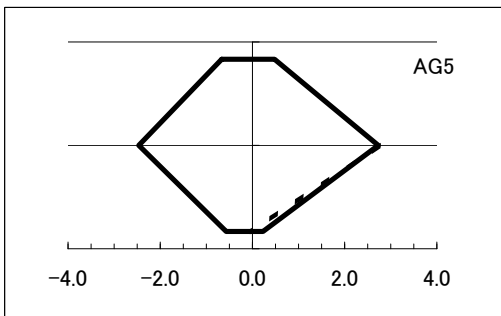
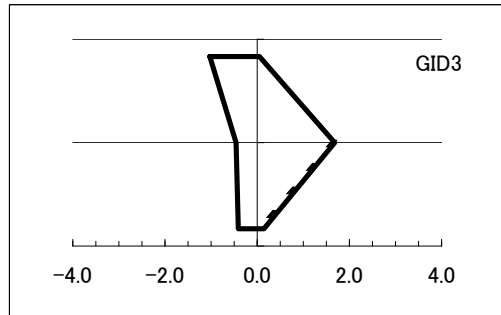
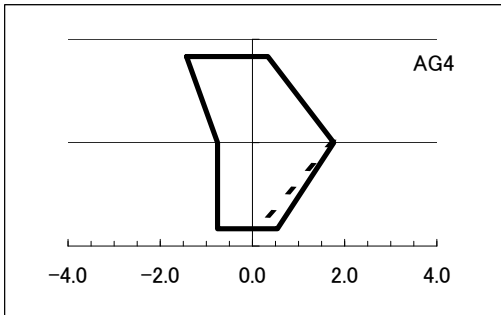
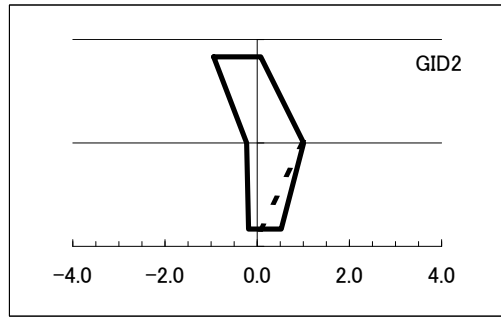
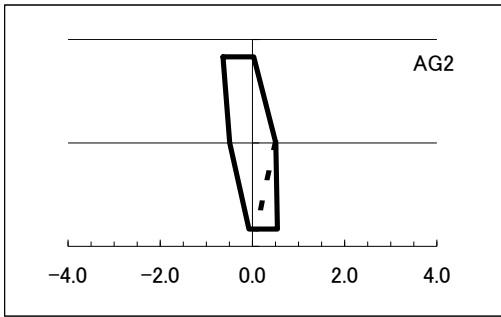

Data 3.3 Hexa Diagram of Water Quality Samples (6/11)

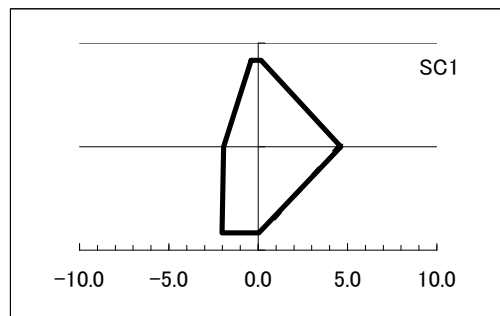
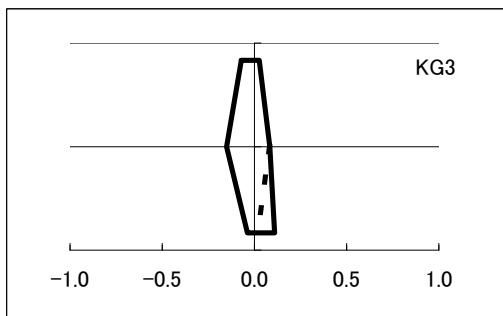
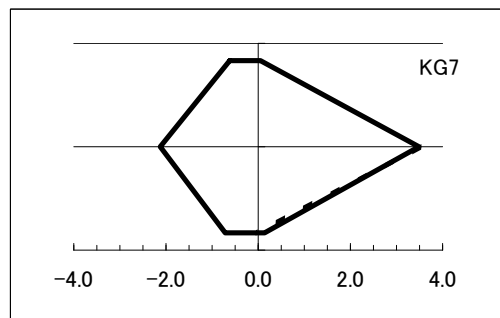
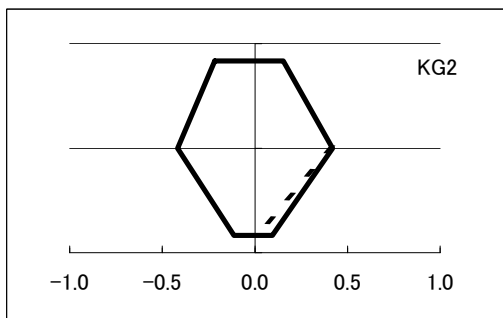
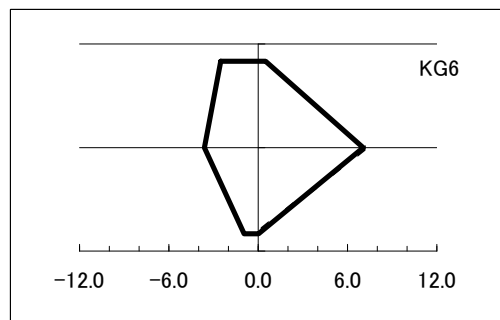
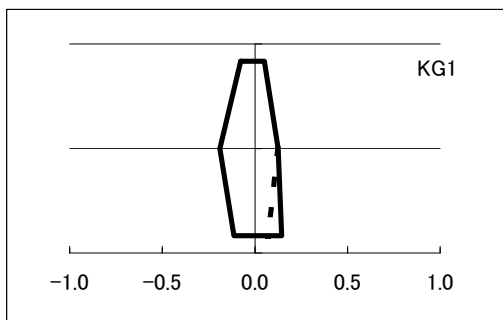
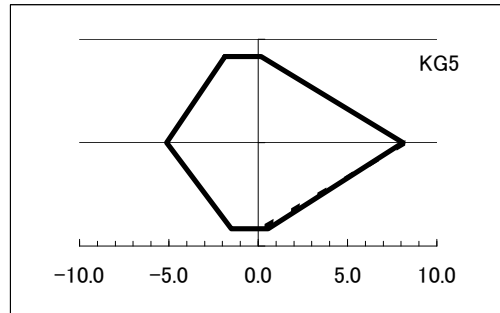
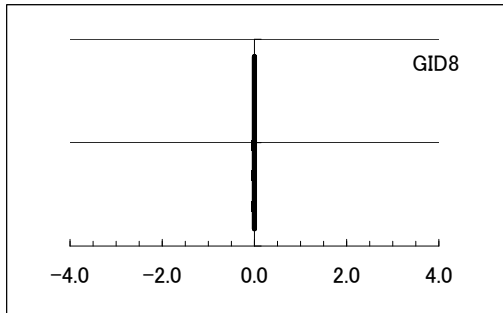
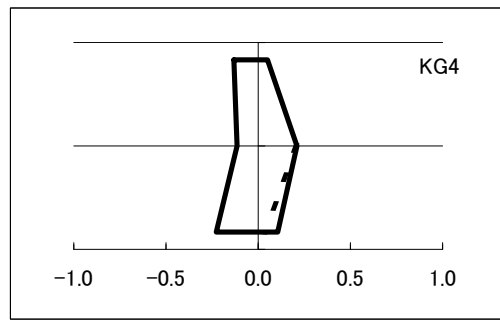
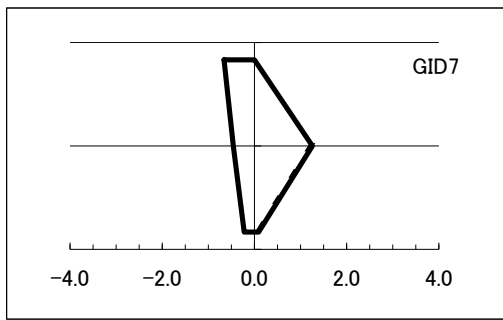

Data 3.3 Hexa Diagram of Water Quality Samples (7/11)

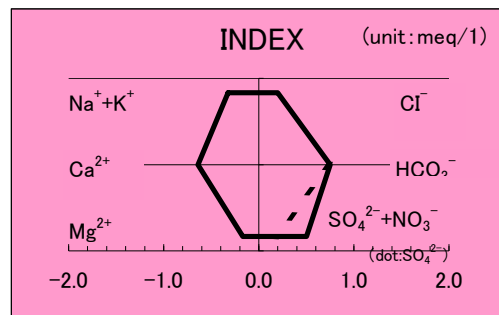
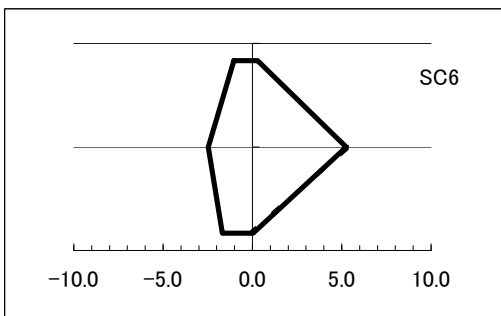
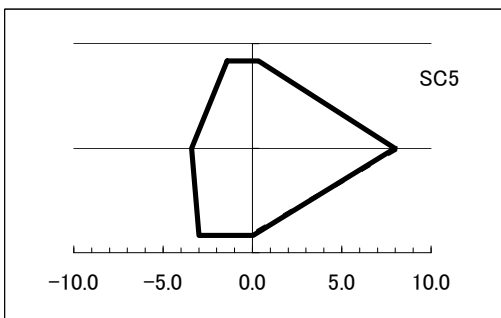
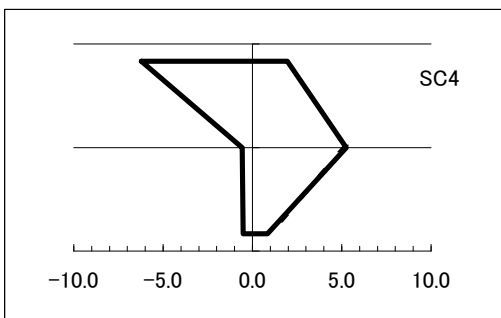
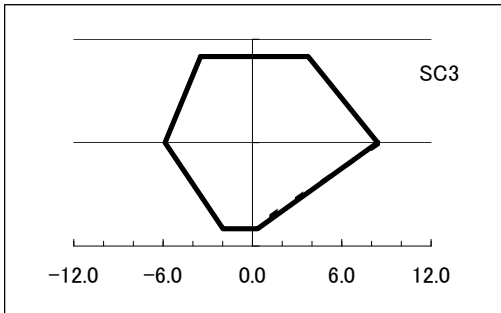
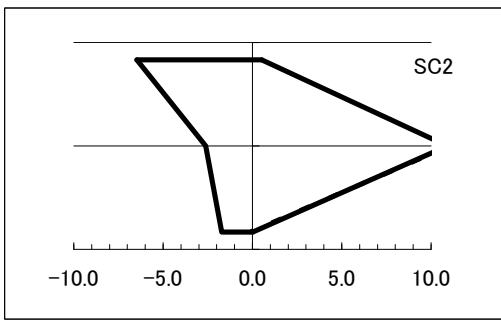

Data 3.3 Hexa Diagram of Water Quality Samples (8/11)

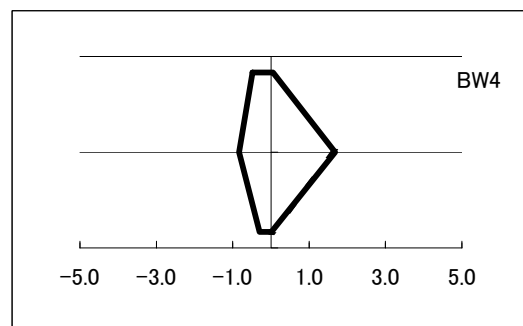
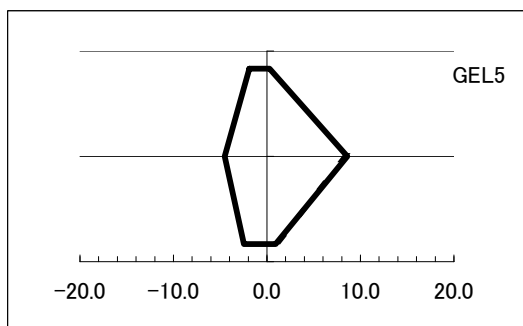
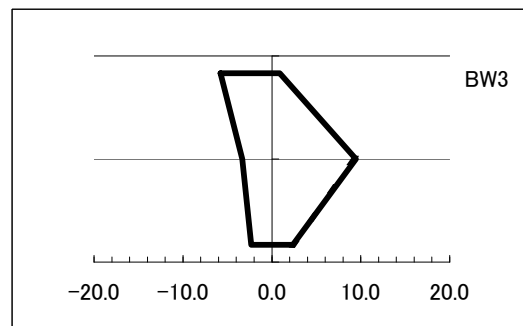
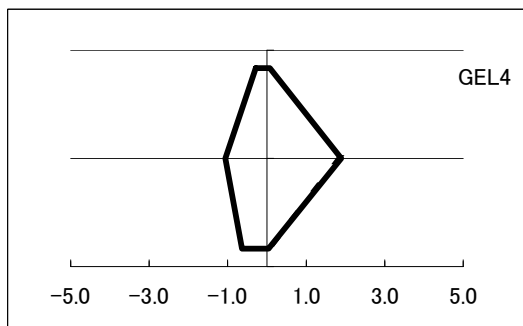
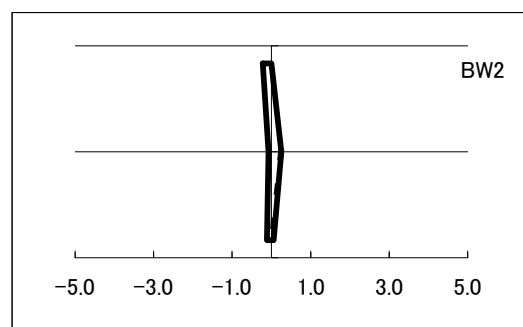
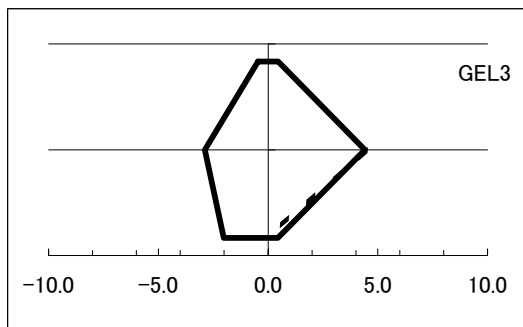
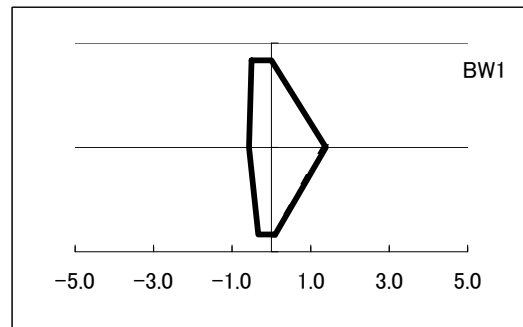
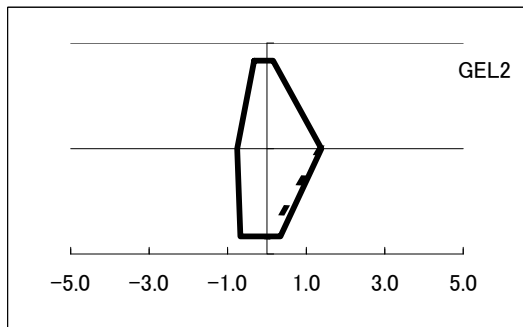
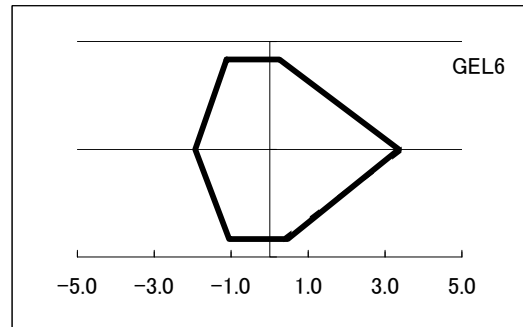
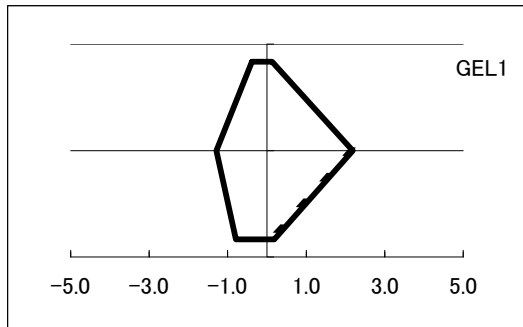

Data 3.3 Hexa Diagram of Water Quality Samples (9/11)

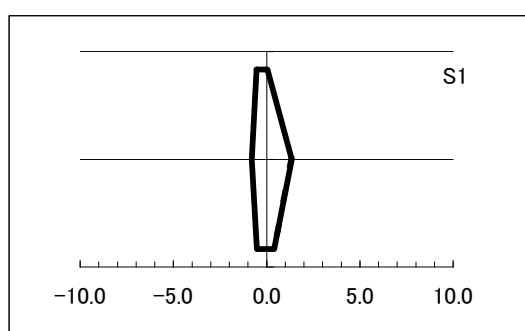
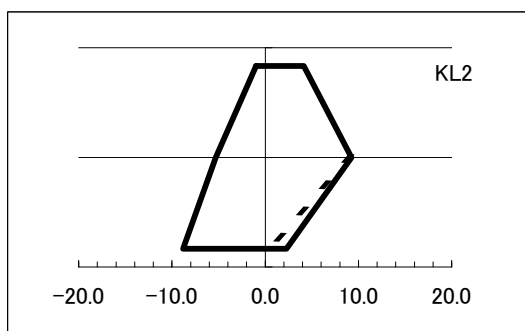
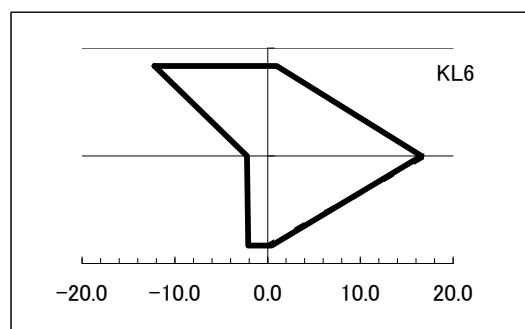
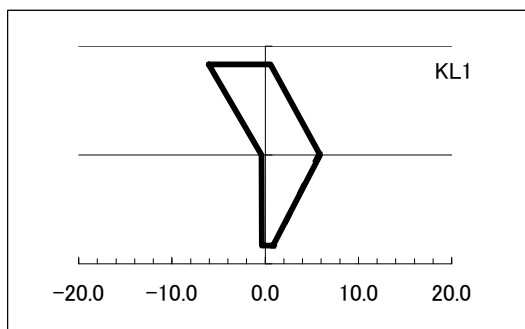
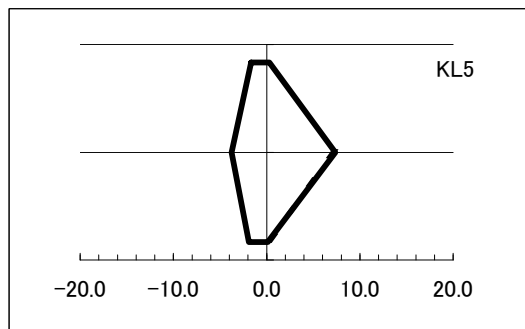
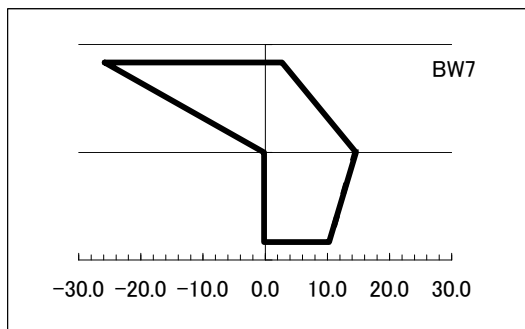
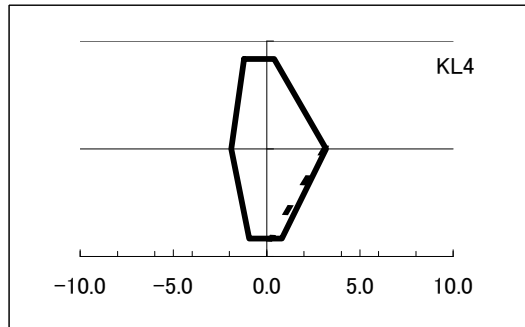
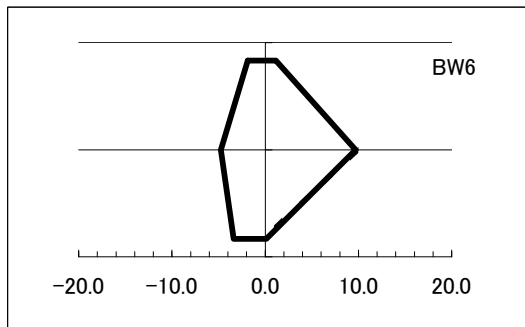
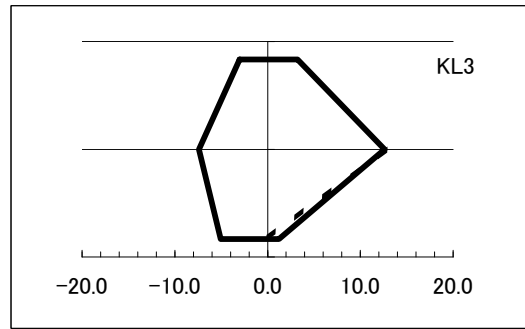
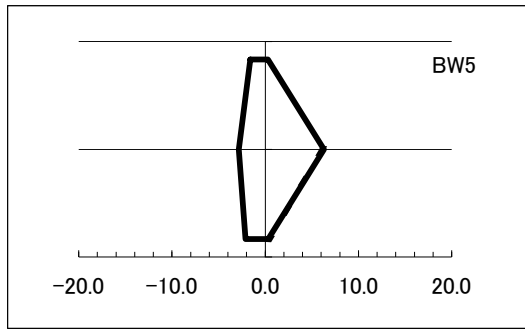

Data 3.3 Hexa Diagram of Water Quality Samples (10/11)

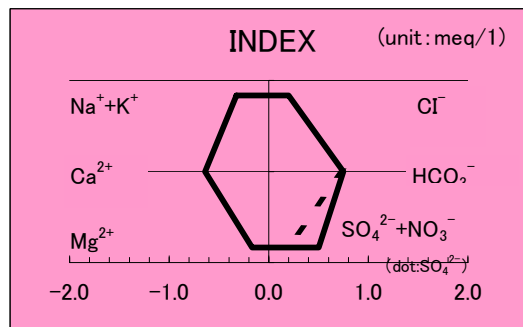
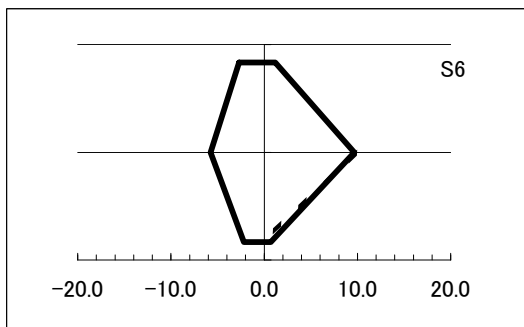
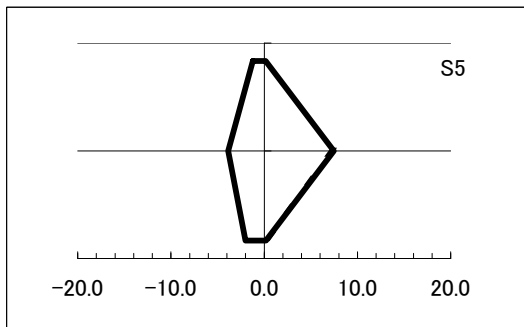
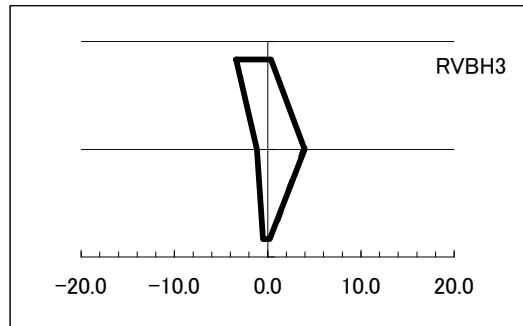
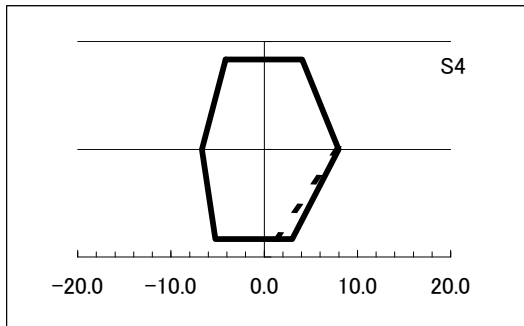
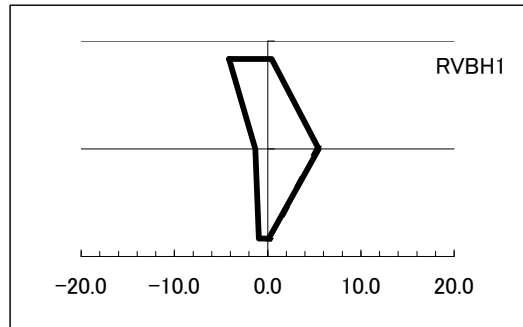
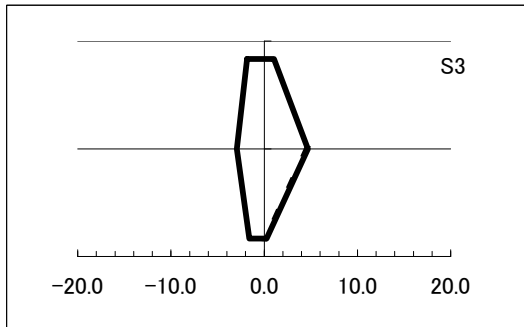
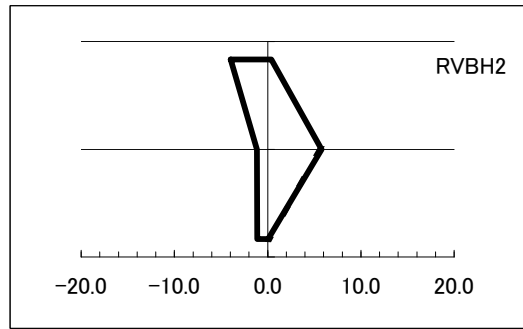
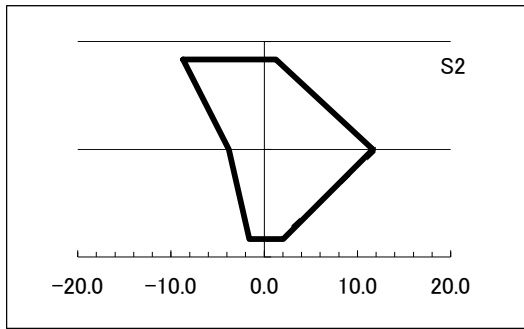

Data 3.3 Hexa Diagram of Water Quality Samples (11/11)

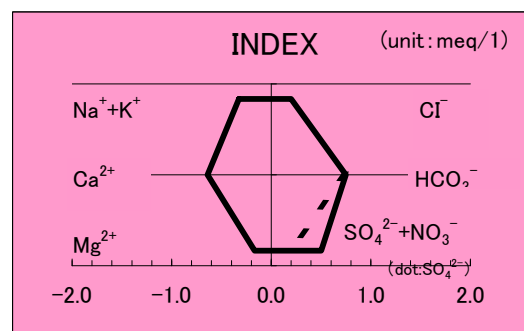
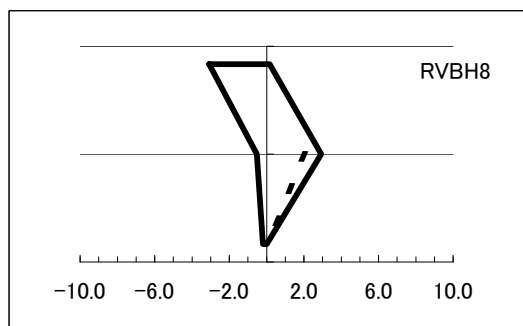
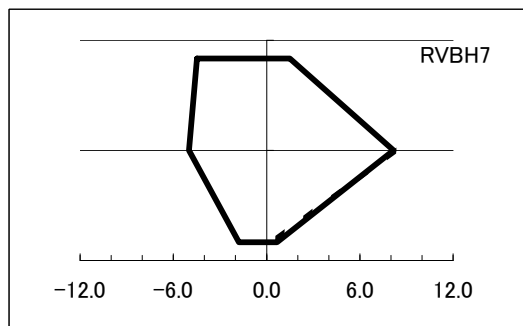
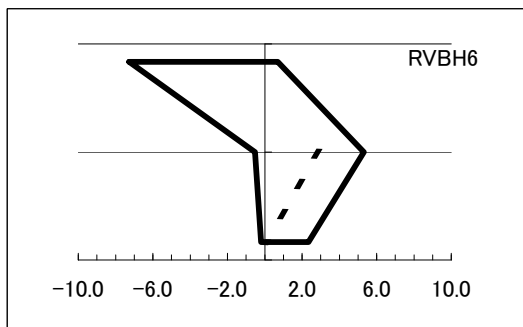
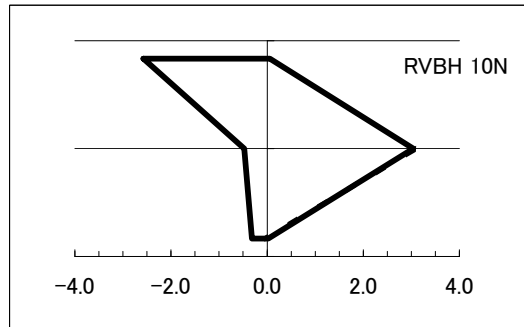
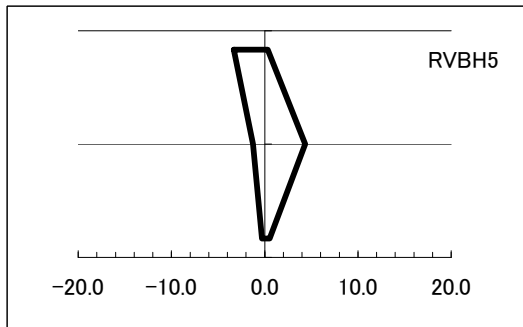
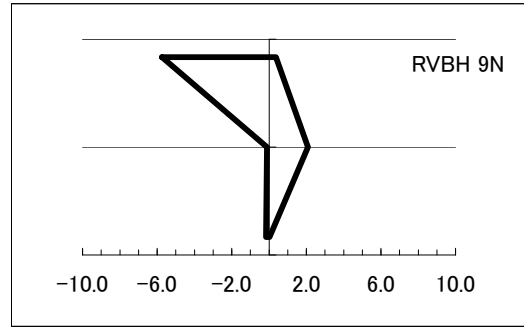
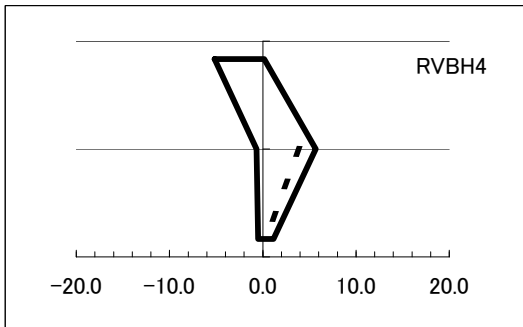

Data 3.4 Water Quality Analysis Results (Site Measurement), (1/3)

CLIENTS ID.NO.	BASIN NAME	SOURCE OF SAMPLE	E	N	EL	Region	Zone	Woreda	Kebele
WZA1	Western Ziway Abjata	Borehole	440353	918436	2711	SNNPRS	Garage	Sodo	Kela
WZA2	Western Ziway Abjata	Borehole	449730	918371	2090	SNNPRS	Garage	Sodo	Bui Zuria
WZA3	Western Ziway Abjata	Borehole	436107	901950	2010	SNNPRS	Garage	Meskan	Drama
WZA4	Western Ziway Abjata	Borehole	425726	887119	2090	SNNPRS	Silte	Silti	Kibet
WZA5	Western Ziway Abjata	Borehole	455903	885591	1781	SNNPRS	Garage	Mareko	Ilala Gebiba
WZA6	Western Ziway Abjata	Borehole	440921	876752	1992	SNNPRS	Silte	Silti	Semen Gotto
WZA7	Western Ziway Abjata	Borehole	465363	869206	1658	Oromia	East Shoa	Adamitulu Jido Combolcha	Haleku
EZ1	Eastern Ziway	Borehole	487471	901966	1649	Oromia	East Shoa	Dugda Bora	Tuchi Sumeya
EZ2	Eastern Ziway	Spring	495889	895142	1644	Oromia	Arsi	Ziway Dugda	Meja Shenen
EZ3	Eastern Ziway	Spring	501886	887839	1672	Oromia	Arsi	Ziway Dugda	Hallo (Ogolcho)
EZ4	Eastern Ziway	Borehole	496746	883403	1701	Oromia	Arsi	Ziway Dugda	Doha Homba
EZ5	Eastern Ziway	Borehole	494507	874562	1728	Oromia	Arsi	Ziway Dugda	Kiansho
EZ6	Eastern Ziway	Spring	485555	872111	1643	Oromia	Arsi	Ziway Dugda	Beshira Chefa
EZ7	Eastern Ziway	Borehole	483552	866076	1658	Oromia	Arsi	Ziway Dugda	Chefe Jila
LS1	Lake Shalla	Spring	410040	872237	2189	SNNPRS	Silte	Wulbareg	Date Wezir 6
LS2	Lake Shalla	Spring	414532	863503	1955	SNNPRS	Silte	Dalocha	Burka Dilapha
LS3	Lake Shalla	Borehole	418241	860616	1952	SNNPRS	Silte	Dalocha	Dalocha Talikesa
LS4	Lake Shalla	Spring	399929	862339	2020	SNNPRS	Silte	Wulbareg	Lemerabe
LS5	Lake Shalla	Borehole	428438	848990	1809	SNNPRS	Silte	Lanfuro	Mito
LS6	Lake Shalla	Spring	427992	844274	1749	SNNPRS	Silte	Lanfuro	Adeneba Egawo
LL10	Lake Langano	Borehole	418721	805135	1888	SNNPRS	-	Alaba Kulito	Yeji
LL11	Lake Langano	Spring	468785	799753	2166	Oromia	West Arsi	Arsi Negele	Wotera Shegulle
LL12	Lake Langano	Spring	481628	820252	2078	Oromia	West Arsi	Arsi Negele	Degaga
LL7	Lake Langano	Borehole	409686	836778	1875	SNNPRS	Silte	Sankura	Alemgebeaya
LL8	Lake Langano	Spring	413167	831630	1909	SNNPRS	Silte	Sankura	Menzo Gumba
LL9	Lake Langano	Borehole	414849	823508	2031	SNNPRS	Silte	Sankura	Regdina Mazonia
LA1	Lake Awassa	Borehole	443437	793228	1757	Oromia	Oromia	Shashemene	Kore Borjota
LA2	Lake Awassa	Spring	458768	783746	1805	SNNPRS	Sidama	Wondogenet	Wosha Soyama
LA3	Lake Awassa	Borehole	426456	778055	1682	SNNPRS	Sidama	Awassa	Kajima Umbullo
LA4	Lake Awassa	Borehole	443296	778694	1716	SNNPRS	Sidama	Awassa	Awassa, Roman Penision
LA5	Lake Awassa	Borehole	444891	775368	1743	SNNPRS	Sidama	Awassa	Fara
LA6	Lake Awassa	Spring	459970	773976	2458	SNNPRS	Sidama	Wondogenet	Kelela
LA7	Lake Awassa	Borehole	451604	766446	2184	SNNPRS	Sidama	Melga	Wujjira
B1	Bilate	Spring	410411	892498	3133	SNNPRS	Silte	Alicho Wuriro	Aduji
B2	Bilate	Borehole	385835	846152	2245	SNNPRS	Hadiya	Ana Lemo	Fonko
B3	Bilate	Borehole	398961	808650	1748	SNNPRS	-	Alaba Kulito, Special Woreda	Zobichame, Alaba
B4	Bilate	Borehole	383940	782096	1900	SNNPRS	Wolayita	Damat Gale	Shakisho Shone
B5	Bilate	Borehole	374310	770488	2029	SNNPRS	Wolayita	Damat Gale	Doge
B6	Bilate	Spring	403733	766423	1486	SNNPRS	Wolayita	Duguna Fango	Dimtu
AG1	Amessa Giuracha	Borehole	363549	755433	1540	SNNPRS	Wolayita	Sodo	Sodo town
AG2	Amessa Giuracha	Spring	379661	743494	1406	SNNPRS	Wolayita	Humbo	Abela Gefeta
AG4	Amessa Giuracha	Spring	354515	723336	1675	SNNPRS	Gamo Gofa	Boreda	Mesa Bunteza
AG5	Amessa Giuracha	Spring	352367	718157	2051	SNNPRS	Gamo Gofa	Boreda	Meteka Mele
AG6	Amessa Giuracha	Spring	347611	713476	2311	SNNPRS	Gamo Gofa	Boreda	Dega Zonga
GID1	Gidabo	Borehole	439758	758653	1864	SNNPRS	Sidama	Shebedino	Dharemesa
GID2	Gidabo	Spring	437914	752804	1783	SNNPRS	Sidama	Dale	Waycho
GID3	Gidabo	Borehole	428711	732018	1836	SNNPRS	Sidama	Tula	Dala
GID4	Gidabo	Hand dug well	431158	747805	1733	SNNPRS	Sidama	Chuko	Korke
GID5	Gidabo	Borehole	423693	720045	1653	SNNPRS	Sidama	Chuko	Teso
GID6	Gidabo	Spring	427829	706831	1826	SNNPRS	Gedeo	Wenago	Andida
GID7	Gidabo	Borehole	420043	700578	1591	SNNPRS	Gedeo	Wenago	Tumata Chirecha
GID8	Gidabo	Borehole	435472	752315	1789	SNNPRS	Sidama	Dale	Chume
KG1	Kulfo Gina	Spring	345897	704036	2713	SNNPRS	Gamo Gofa	Chencha	Gule
KG2	Kulfo Gina	Spring	342307	691646	2719	SNNPRS	Gamo Gofa	Chencha	1
KG3	Kulfo Gina	Spring	342008	684900	2464	SNNPRS	Gamo Gofa	Chencha	Dorze
KG4	Kulfo Gina	Spring	343470	682077	2134	SNNPRS	Gamo Gofa	Chencha	Tegecha
KG5	Kulfo Gina	Borehole	351823	681377	1193	SNNPRS	Gamo Gofa	West Abaya	Omo Lante
KG6	Kulfo Gina	Spring	335938	664942	2233	SNNPRS	Gamo Gofa	Arbaminch	Bere
KG7	Kulfo Gina	Spring	340514	663331	1189	SNNPRS	Gamo Gofa	Arbaminch	Arbaminch
SC1	Sife Chamo	Spring	313955	652539	1910	SNNPRS	Gamo Gofa	Bonke	Bonke 01 kebele
SC2	Sife Chamo	Spring	325813	650053	1188	SNNPRS	Gamo Gofa	Arbaminch Zuria	Elgo Donbe
SC3	Sife Chamo	Spring	323955	631606	1277	SNNPRS	Derashe special woreda	Derashe special woreda	Argaba
SC4	Sife Chamo	Borehole	327646	623373	1186	SNNPRS	Derashe special woreda	Derashe special woreda	Ynuta
SC5	Sife Chamo	Borehole	337178	618029	1595	SNNPRS	Konso special woreda	Konso special woreda	Segen Genet
SC6	Sife Chamo	Borehole	340044	618188	1634	SNNPRS	Konso special woreda	Konso special woreda	Segen
GEL1	Gelana	Spring	413097	680370	1870	SNNPRS	Gedeo	Yirgachefe	Koke
GEL2	Gelana	Borehole	410584	669815	2002	SNNPRS	Gedeo	Kochore	Hama
GEL3	Gelana	Borehole	407554	667733	1981	SNNPRS	Gedeo	Kochore	Kore
GEL4	Gelana	Borehole	415473	659170	2320	SNNPRS	Gedeo	Gedeb	Harmufo
GEL5	Gelana	Spring	408449	633710	1933	OROMIA	Borena	Dugda dawa	Burka Arbichu
GEL6	Gelana	Spring	413840	621971	1841	SNNPRS	Borena	Bule Hora	Bule Kenga
BW1	Bezo Weyto	Spring	299599	669160	2020	SNNPRS	Gamo Gofa	Kemba	Laea
BW2	Bezo Weyto	Spring	308307	666051	2730	SNNPRS	Gamo Gofa	Kemba	Beltatelo
BW3	Bezo Weyto	Borehole	273519	641784	1401	SNNPRS	South Omo	Male	Aleze
BW4	Bezo Weyto	Spring	241142	645216	1965	SNNPRS	South Omo	South Ari	Senegal
BW5	Bezo Weyto	Borehole	251507	631850	1231	SNNPRS	South Omo	Male	Beneta
BW6	Bezo Weyto	Borehole	255007	634334	1583	SNNPRS	South Omo	Bena Tsemay	Key Afer
BW7	Bezo Weyto	Borehole	276955	593722	555	SNNPRS	South Omo	Bena Tsemay	Birale
KL1	Konso localaized	Borehole	327166	602575	1200	SNNPRS	Konso special woreda	Konso special woreda	Kishmare
KL2	Konso localaized	Borehole	314964	598185	1562	SNNPRS	Konso special woreda	Konso special woreda	Arefayda
KL3	Konso localaized	Borehole	328501	592901	1351	SNNPRS	Konso special woreda	Konso special woreda	Dokato
KL4	Konso localaized	Borehole	317473	583296	1767	SNNPRS	Konso special woreda	Konso special woreda	Gesergio
KL5	Konso localaized	Borehole	328439	581952	1522	SNNPRS	Konso special woreda	Konso special woreda	Gera
KL6	Konso localaized	Borehole	341546	591483	948	SNNPRS	Konso special woreda	Konso special woreda	Jarso
S1	Segen	Spring	366914	649685	1828	SNNPRS	Amaro kele special woreda	Amaro kele special woreda	Amaro kele
S2	Segen	Borehole	351528	594777	1790	SNNPRS	Konso special woreda	Konso special woreda	Jarso
S3	Segen	Borehole	374494	605132	1804	SNNPRS	Burji special woreda	Burji special woreda	Soyama
S4	Segen	Borehole	372374	600999	1714	SNNPRS	Burji special woreda	Burji special woreda	Lemo
S5	Segen	Spring	374259	599528	1830	SNNPRS	Burji special woreda	Burji special woreda	Lemo
S6	Segen	Borehole	321726	559650	1358	OROMIA	Borena	Bilemi	Tettele
RVS BH-2	Test Borehole	Borehole	486760	907780		ORMIYA	East Shoa	Boro	Berta Sami
RVS BH-1	Test Borehole	Borehole	383515	734720		SNNPRS	Welaia	Kumbo	Abay Chokere
RVS BH-3	Test Borehole	Borehole	447623	795610	1801	OROMIYA	West Arsi	Shashemne	Mega Dema

Note: Shaded items exceed the Ethiopian drinking water standards

Data 3.4 Water Quality Analysis Results (Site Measurement), (2/3)

CLIENTS ID.NO.	BASIN NAME	SOURCE OF SAMPLE	Village		Temperature	EC(ms/m)	pH	ORP(mv)	Iron (Fe)	Manganese (Mn)
WZA1	Western Ziway Abjata	Borehole		16.6.10	21.2	12.6	6.55	229	Trace	Trace
WZA2	Western Ziway Abjata	Borehole		16.6.10	26.3	40.1	7.88	246	Trace	Trace
WZA3	Western Ziway Abjata	Borehole	Road Side	16.6.10	24.6	38.1	7.36	266	Trace	Trace
WZA4	Western Ziway Abjata	Borehole		16.6.10	23.9	48.4	6.89	239	Trace	Trace
WZA5	Western Ziway Abjata	Borehole	Wuha Limiat	17.6.10	28.4	89.4	8.70	202	Trace	Trace
WZA6	Western Ziway Abjata	Borehole	Semen Limat	17.6.10	25.8	70.9	7.53	220	Trace	Trace
WZA7	Western Ziway Abjata	Borehole	Heleku	17.6.10	28.7	97.4	8.38	216	Trace	Trace
EZ1	Eastern Ziway	Borehole	Sumeya	18.6.10	26.0	112.1	8.08	198	Trace	Trace
EZ2	Eastern Ziway	Spring	Burkitu	18.6.10	23.1	38.6	7.57	205	Trace	Trace
EZ3	Eastern Ziway	Spring	Ogolcho	18.6.10	22.7	26.9	7.70	210	Trace	Trace
EZ4	Eastern Ziway	Borehole	Daho Hombo	18.6.10	23.9	109.4	8.17	204	Trace	Trace
EZ5	Eastern Ziway	Borehole	Kiansho	18.6.10	24.9	36.4	7.92	220	Trace	Trace
EZ6	Eastern Ziway	Spring	Beshira Kombolcha	17.6.10	27.0	29.5	8.11	273	Trace	Trace
EZ7	Eastern Ziway	Borehole	Chefe Jilla	17.6.10	30.1	72.5	7.85	230	Trace	Trace
LS1	Lake Shalla	Spring	Chercher	16.6.10	21.6	9.5	6.79	230	Trace	Trace
LS2	Lake Shalla	Spring	Gafat	16.6.10	26.4	36.0	7.40	176	Trace	Trace
LS3	Lake Shalla	Borehole	Dalocha Talikessa	15.6.10	26.6	39.5	7.67	230	Trace	Trace
LS4	Lake Shalla	Spring		16.6.10	28.8	16.0	7.11	290	Trace	Trace
LS5	Lake Shalla	Borehole		15.6.10	23.7	43.4	7.42	245	Trace	Trace
LS6	Lake Shalla	Spring		15.6.10	24.6	53.9	7.40	193	Trace	Trace
LL10	Lake Langano	Borehole		13.6.10	24.1	73.1	8.22	190	Trace	Trace
LL11	Lake Langano	Spring		13.6.10	20.1	14.0	6.35	198	Trace	Trace
LL12	Lake Langano	Spring		13.6.10	20.2	18.9	5.92	250	Trace	Trace
LL7	Lake Langano	Borehole		15.6.10	26.5	65.9	7.61	180	Trace	Trace
LL8	Lake Langano	Spring		15.6.10	24.5	63.1	8.04	160	Trace	Trace
LL9	Lake Langano	Borehole		15.6.10	27.8	59.0	7.80	210	Trace	Trace
LA1	Lake Awassa	Borehole		11.6.10	25.5	261.0	7.41	230	Trace	Trace
LA2	Lake Awassa	Spring		11.6.10	20.7	16.3	6.41	240	Trace	Trace
LA3	Lake Awassa	Borehole		10.6.10	25.1	142.0	7.89	750	Trace	Trace
LA4	Lake Awassa	Borehole		10.6.10	30.8	108.2	7.79	250	Trace	Trace
LA5	Lake Awassa	Borehole		10.6.10	24.4	114.2	7.55	242	Trace	Trace
LA6	Lake Awassa	Spring		11.6.10	23.1	18.6	7.07	312	Trace	Trace
LA7	Lake Awassa	Borehole		10.6.10	18.9	12.2	8.67	250	0.30	Trace
B1	Bilate	Spring		16.6.10	15.6	8.3	6.40	210	Trace	Trace
B2	Bilate	Borehole		16.6.10	22.3	19.7	6.94	256	Trace	Trace
B3	Bilate	Borehole		12.6.10	30.1	54.2	8.02	200	Trace	Trace
B4	Bilate	Borehole		12.6.10	28.6	70.4	7.77	180	Trace	Trace
B5	Bilate	Borehole		12.6.10	29.6	29.8	7.71	166	Trace	Trace
B6	Bilate	Spring		9.6.10	35.8	103.6	7.30	231	Trace	Trace
AG1	Amessa Giuracha	Borehole	ATVT Collage	08.06.10	21.5	16.27	7.02	-3241	Trace	Trace
AG2	Amessa Giuracha	Spring	Kele Gefeta	07.06.10	26.3	13.89	6.25	-3242	Trace	Trace
AG4	Amessa Giuracha	Spring	Merkato	08.06.10	26.0	29.10	6.14	-3247	Trace	Trace
AG5	Amessa Giuracha	Spring	Unde	08.06.10	24.4	36.30	6.46	-336	Trace	Trace
AG6	Amessa Giuracha	Spring	Sula Subo	08.06.10	20.0	35.80	7.21	-339	Trace	Trace
GID1	Gidabo	Borehole		7.6.10	23.0	20.5	6.64	880	Trace	Trace
GID2	Gidabo	Spring		7.6.10	20.6	13.5	5.80	898	Trace	Trace
GID3	Gidabo	Borehole		8.6.10	22.9	18.1	6.13	727	Trace	Trace
GID4	Gidabo	Hand dug well		8.6.10	21.6	14.4	6.30	995	Trace	Trace
GID5	Gidabo	Borehole		8.6.10	23.2	18.8	6.15	440	0.10	Trace
GID6	Gidabo	Spring		9.6.10	18.7	6.3	5.77	890	Trace	Trace
GID7	Gidabo	Borehole		8.6.10	23.9	12.8	6.20	912	Trace	Trace
GID8	Gidabo	Borehole	Meda Tuola	17.07.10	22.0	19.23	6.16	-2143	Trace	Trace
KG1	Kulfo Gina	Spring	Zaro	08.06.10	16.9	3.22	5.93	-154	Trace	Trace
KG2	Kulfo Gina	Spring	Chencha town	08.06.10	16.6	7.15	5.75	-645	Trace	Trace
KG3	Kulfo Gina	Spring	Dorze town	09.06.10	17.7	2.58	5.85	2146	Trace	Trace
KG4	Kulfo Gina	Spring	Deso	09.06.10	17.6	4.48	5.73	710	Trace	Trace
KG5	Kulfo Gina	Borehole	Lante town	09.06.10	25.0	76.80	7.01	-451	Trace	Trace
KG6	Kulfo Gina	Spring	Mariam Church	09.06.10	29.5	34.20	7.41	-1149	Trace	Trace
KG7	Kulfo Gina	Spring	Arbaminch	09.06.10	22.8	67.20	7.41	86	Trace	Trace
SC1	Sife Chamo	Spring	Bone	10.06.10	21.6	40.60	6.95	-260	Trace	Trace
SC2	Sife Chamo	Spring	Donbe	10.06.10	26.5	100.80	7.77	-181	Trace	Trace
SC3	Sife Chamo	Spring	ArgubaTenao	12.06.10	25.2	129.40	6.99	74	Trace	Trace
SC4	Sife Chamo	Borehole	Mender	12.06.10	26.9	77.40	8.30	-598	Trace	Trace
SC5	Sife Chamo	Borehole	Gemduro	12.06.10	24.2	69.40	6.80	168	Trace	Trace
SC6	Sife Chamo	Borehole	Segen town/Gumayde	12.06.10	22.6	48.30	7.23	588	Trace	Trace
GEL1	Gelana	Spring	Koke spring	18.06.10	20.0	23.30	6.57	41	Trace	Trace
GEL2	Gelana	Borehole	Argeno	17.06.10	20.0	20.60	6.31	500	Trace	Trace
GEL3	Gelana	Borehole	Debeka	17.06.10	20.2	51.80	7.37	356	Trace	Trace
GEL4	Gelana	Borehole	Saharo	18.06.10	16.8	19.05	7.07	1620	Trace	Trace
GEL5	Gelana	Spring	Oitu	18.06.10	20.3	83.00	7.29	352	Trace	Trace
GEL6	Gelana	Spring	Hagermarian town	18.06.10	23.0	36.80	7.20	230	Trace	Trace
BW1	Bezo Weyto	Spring	Ache	10.06.10	19.6	13.35	6.85	34	Trace	Trace
BW2	Bezo Weyto	Spring	Chengea	10.06.10	15.3	4.68	7.68	-206	Trace	Trace
BW3	Bezo Weyto	Borehole	Delokayo	14.06.10	23.8	105.70	7.23	301	Trace	Trace
BW4	Bezo Weyto	Spring	Senegal	14.06.10	19.1	16.60	6.93	725	Trace	Trace
BW5	Bezo Weyto	Borehole	Aluba	14.06.10	25.3	60.50	7.80	697	Trace	Trace
BW6	Bezo Weyto	Borehole	Key Afer town	13.06.10	22.0	49.20	7.03	1469	Trace	Trace
BW7	Bezo Weyto	Borehole	Woyto	13.06.10	32.0	0.30	8.30	363	Trace	Trace
KL1	Konso localaized	Borehole	Lihaita	13.06.10	27.2	65.90	8.38	363	Trace	Trace
KL2	Konso localaized	Borehole	Guma	13.06.10	24.4	146.00	8.18	233	Trace	Trace
KL3	Konso localaized	Borehole	Gire Bensa	13.06.10	28.0	16.34	6.80	276	Trace	Trace
KL4	Konso localaized	Borehole	New York	15.06.10	24.4	41.70	7.22	-3244	Trace	Trace
KL5	Konso localaized	Borehole	Konata	15.06.10	24.5	70.30	7.36	-192	Trace	Trace
KL6	Konso localaized	Borehole	Moreteta	15.06.10	33.5	153.40	7.54	283	Trace	Trace
S1	Segen	Spring	Kele town	16.06.10	23.0	19.84	7.56	367	Trace	Trace
S2	Segen	Borehole	Geldeha	15.06.10	27.3	122.10	7.51	-560	Trace	Trace
S3	Segen	Borehole	Soyama town	16.06.10	23.8	56.60	7.20	-1090	Trace	Trace
S4	Segen	Borehole	Goro	16.06.10	23.1	159.00	6.73	-71	Trace	Trace
S5	Segen	Spring	Komolcha	16.06.10	21.8	64.80	7.34	-2853	Trace	Trace
S6	Segen	Borehole	Teltele town	16.06.10	26.9	103.80	7.39	-37	Trace	Trace
RVS BH-2	Test Borehole	Borehole	Sami	10.06.10	-	54.50	7.55	2526	Trace	Trace
RVS BH-1	Test Borehole	Borehole		07.06.10	32.1	56.9	7.19	707	Trace	Trace
RVS BH-3	Test Borehole	Borehole	Mega Dema	02.08.10	30.0	47.4	7.09	750	Trace	Trace

Note: Shaded items exceed the Ethiopian drinking water standards

Data 3.4 Water Quality Analysis Results (Site Measurement), (3/3)

CLIENTS ID.NO.	BASIN NAME	SOURCE OF SAMPLE	Fluoride (F)	Nitrate (NO3)	Arsenic (As)	Ammonium (NH4)	Coliform(count/100)	General Bacteria
WZA1	Western Ziway Abjata	Borehole	0.4	1.0	-	0.2	29	25
WZA2	Western Ziway Abjata	Borehole	0.8	1.0	-	0.5	-	-
WZA3	Western Ziway Abjata	Borehole	0.8	2.0	-	0.5	4	6
WZA4	Western Ziway Abjata	Borehole	0.8	2.0	-	0.2	8	3
WZA5	Western Ziway Abjata	Borehole	3.0	Trace	-	0.2	12	16
WZA6	Western Ziway Abjata	Borehole	1.5	2.0	-	0.5	-	-
WZA7	Western Ziway Abjata	Borehole	3.0	Trace	-	0.2	1	8
EZ1	Eastern Ziway	Borehole	3.0	Trace	-	0.2	10	14
EZ2	Eastern Ziway	Spring	1.5	1.0	-	0.2	12	8
EZ3	Eastern Ziway	Spring	0.8	2.0	-	0.2	15	4
EZ4	Eastern Ziway	Borehole	3.0	Trace	-	0.2	2	-
EZ5	Eastern Ziway	Borehole	1.5	Trace	-	0.2	-	-
EZ6	Eastern Ziway	Spring	1.5	1.0	-	0.2	5	6
EZ7	Eastern Ziway	Borehole	3.0	1.0	-	0.2	-	-
LS1	Lake Shalla	Spring	0.4	2.0	-	0.2	2	3
LS2	Lake Shalla	Spring	1.5	1.0	-	0.2	-	5
LS3	Lake Shalla	Borehole	1.5	2.0	-	0.2	2	6
LS4	Lake Shalla	Spring	0.8	1.0	-	0.2	5	8
LS5	Lake Shalla	Borehole	0.8	2.0	-	0.2	-	-
LS6	Lake Shalla	Spring	1.5	2.0	-	0.5	12	-
LL10	Lake Langano	Borehole	3.0	2.0	-	0.2	3	5
LL11	Lake Langano	Spring	0.4	10.0	-	0.5	12	8
LL12	Lake Langano	Spring	0.4	20.0	-	0.5	43	50
LL7	Lake Langano	Borehole	1.5	1.0	-	0.2	-	-
LL8	Lake Langano	Spring	1.5	1.0	-	0.2	6	9
LL9	Lake Langano	Borehole	1.5	1.0	-	0.2	-	-
LA1	Lake Awassa	Borehole	3.0	Trace	-	0.5	1	-
LA2	Lake Awassa	Spring	0.4	1.0	-	1.0	2	5
LA3	Lake Awassa	Borehole	3.0	20.0	-	1.0	70	90
LA4	Lake Awassa	Borehole	3.0	2.0	-	0.5	5	7
LA5	Lake Awassa	Borehole	3.0	5.0	-	0.5	1	2
LA6	Lake Awassa	Spring	0.4	2.0	-	1.0	4	2
LA7	Lake Awassa	Borehole	0.8	Trace	-	1.0	3	2
B1	Bilate	Spring	0.4	2.0	-	0.2	1	-
B2	Bilate	Borehole	0.8	Trace	-	0.2	1	-
B3	Bilate	Borehole	1.5	Trace	-	1.0	8	10
B4	Bilate	Borehole	1.5	Trace	-	0.5	7	5
B5	Bilate	Borehole	0.8	5.0	-	0.5	-	-
B6	Bilate	Spring	3.0	2.0	-	0.5	1	5
AG1	Amessa Giuracha	Borehole	0.8	1.0	-	2.0	11	10
AG2	Amessa Giuracha	Spring	0.4	10.0	-	0.5	8	10
AG4	Amessa Giuracha	Spring	0.4	20.0	-	0.5	28	64
AG5	Amessa Giuracha	Spring	Trace	5.00	-	0.5	30	50
AG6	Amessa Giuracha	Spring	0.4	1.0	-	0.2	12	26
GID1	Gidabo	Borehole	0.8	5.0	-	0.5	3	2
GID2	Gidabo	Spring	0.8	5.0	-	0.5	15	22
GID3	Gidabo	Borehole	0.4	1.0	-	0.2	3	-
GID4	Gidabo	Hand dug well	0.4	2.0	-	0.5	14	17
GID5	Gidabo	Borehole	0.4	5.0	-	0.5	-	-
GID6	Gidabo	Spring	0.4	5.0	-	1.0	6	10
GID7	Gidabo	Borehole	0.4	5.0	-	0.5	1	3
GID8	Gidabo	Borehole	0.4	2.0	-	0.2	-	1
KG1	Kulfo Gina	Spring	0.4	5.00	-	0.2	8	5
KG2	Kulfo Gina	Spring	0.4	10.00	-	0.5	30	46
KG3	Kulfo Gina	Spring	0.4	2.0	-	0.2	20	13
KG4	Kulfo Gina	Spring	0.4	2.0	-	0.2	16	12
KG5	Kulfo Gina	Borehole	0.4	10.00	-	0.5	15	14
KG6	Kulfo Gina	Spring	0.4	5.00	-	0.5	3	6
KG7	Kulfo Gina	Spring	0.4	1.0	-	0.5	2	10
SC1	Sife Chamo	Spring	0.4	2.0	-	0.2	19	12
SC2	Sife Chamo	Spring	0.4	1.0	-	0.2	31	13
SC3	Sife Chamo	Spring	0.4	45.0	-	0.2	3	6
SC4	Sife Chamo	Borehole	0.4	1.0	-	0.2	45	15
SC5	Sife Chamo	Borehole	0.4	1.0	-	0.2	5	-
SC6	Sife Chamo	Borehole	0.4	1.0	-	0.2	65	9
GEL1	Gelana	Spring	0.0	5.0	-	0.2	31	34
GEL2	Gelana	Borehole	0.4	5.0	-	0.2	1	-
GEL3	Gelana	Borehole	0.4	45.0	-	0.2	-	-
GEL4	Gelana	Borehole	0.4	2.0	-	0.5	22	3
GEL5	Gelana	Spring	0.4	1.0	-	0.5	37	70
GEL6	Gelana	Spring	0.8	2.0	-	0.5	1	6
BW1	Bezo Weyto	Spring	0.4	2.00	-	0.2	-	5
BW2	Bezo Weyto	Spring	0.4	2.0	-	0.5	-	-
BW3	Bezo Weyto	Borehole	0.0	2.0	-	0.2	5	50
BW4	Bezo Weyto	Spring	0.4	1.0	-	0.2	20	26
BW5	Bezo Weyto	Borehole	0.8	5.0	-	0.2	16	5
BW6	Bezo Weyto	Borehole	0.8	10.0	-	0.2	29	52
BW7	Bezo Weyto	Borehole	3.0	20.0	-	0.5	35	18
KL1	Konso localaized	Borehole	0.4	1.00	-	0.2	9	30
KL2	Konso localaized	Borehole	0.4	45.0	-	0.5	-	-
KL3	Konso localaized	Borehole	-	45.00	-	0.5	-	-
KL4	Konso localaized	Borehole	0.4	20.00	-	1.0	5	5
KL5	Konso localaized	Borehole	0.4	2.00	-	0.2	-	1
KL6	Konso localaized	Borehole	0.8	2.0	-	0.5	5	7
S1	Segen	Spring	0.4	1.0	-	0.5	5	3
S2	Segen	Borehole	0.8	1.0	-	0.2	4	3
S3	Segen	Borehole	0.4	10.0	-	0.5	-	-
S4	Segen	Borehole	0.4	45.0	-	0.5	-	-
S5	Segen	Spring	0.4	10.0	-	0.5	50	22
S6	Segen	Borehole	0.4	45.0	-	0.2	4	15
RVS BH-2	Test Borehole	Borehole	1.5	1.0	-	0.2	-	-
RVS BH-1	Test Borehole	Borehole	1.5	1.0	-	1.0	6	5
RVS BH-3	Test Borehole	Borehole	3.0	Trace	-	0.2	28	8

Note: Shaded items exceed the Ethiopian drinking water standards

Data 3.5 Water Quality Analysis Results (Laboratory Measurement), (2/3)

CLIENTS ID.NO.	SOURCE OF SAMPLE	AQUIFER	ROCK FACIES	EC (µS/cm)	PH	Ammonia (mg/l NH3)	Sodium (mg/l Na)	Potassium (mg/l K)	Total Hardness (mg/l Ca)	Calcium (mg/l Ca)	Magnesium (mg/l Mg)	Total Iron (mg/l Fe)	Manganese (mg/l Mn)	Fluoride (mg/l F)
WZA1	Borehole	Qwbh	Basalt flow	132.00	6.39	2.05	7.80	2.10	53.20	13.68	4.56	0.57	Trace	0.56
WZA2	Borehole	N1_2n	Ignimbrite, Welded tuff	400.00	7.79	0.22	55.50	10.60	93.10	26.60	6.38	0.02	0.05	1.18
WZA3	Borehole	Qwbh	Basalt flow	380.00	7.39	0.18	37.50	10.10	112.10	31.92	7.75	0.02	Trace	0.78
WZA4	Borehole	Qdi	Ignimbrite, Tuff	489.00	6.99	0.26	35.00	10.30	178.60	49.40	13.22	0.02	Trace	0.89
WZA5	Borehole	Qdi	Ignimbrite, Tuff	847.00	8.76	0.17	214.00	8.30	19.00	3.80	2.28	0.01	Trace	3.98
WZA6	Borehole	Qdi	Ignimbrite, Tuff	688.00	7.56	0.18	110.00	12.50	133.00	45.60	4.56	0.04	Trace	2.02
WZA7	Borehole	Ql	Lacustrine	944.00	8.39	0.21	228.00	12.70	47.50	7.60	6.84	0.03	0.02	2.28
EZ1	Borehole	Ql	Lacustrine	1102.00	8.03	0.21	280.00	18.50	72.20	19.00	5.93	0.02	Trace	7.41
EZ2	Spring	Ql	Lacustrine	384.00	7.57	0.15	66.00	11.60	58.90	15.20	5.02	0.01	0.02	1.76
EZ3	Spring	Ql	Lacustrine	284.00	7.52	0.18	43.50	9.30	47.50	15.20	2.28	0.02	Trace	1.02
EZ4	Borehole	Ql	Lacustrine	1068.00	8.37	0.14	258.00	6.80	39.90	11.40	2.74	0.01	Trace	1.01
EZ5	Borehole	Qwbh	Basalt flow	357.00	8.02	0.19	40.00	7.90	95.00	22.80	9.12	0.01	0.02	1.33
EZ6	Spring	Qwbh	Basalt flow	288.00	7.79	0.05	39.00	7.00	60.80	15.20	5.47	0.03	0.02	1.83
EZ7	Borehole	Ql	Lacustrine	708.00	7.98	0.20	117.00	12.10	114.00	28.88	10.03	0.01	Trace	1.04
LS1	Spring	Qdi	Ignimbrite, Tuff	93.00	6.62	0.14	7.40	4.60	26.60	6.84	2.28	0.20	Trace	0.51
LS2	Spring	Qwpu	Pumice tuff, Tuff	358.00	7.30	0.09	58.00	9.80	68.40	15.20	7.30	0.01	0.02	2.32
LS3	Borehole	Qdi	Ignimbrite, Tuff	390.00	7.66	0.08	48.00	10.40	112.10	22.80	13.22	0.04	Trace	1.29
LS4	Spring	NQs	Undivided Sediments	157.00	7.00	0.13	26.00	6.90	30.40	5.32	4.10	0.02	0.02	0.57
LS5	Borehole	N1_2n	Ignimbrite, Welded tuff	432.00	7.75	0.31	54.00	10.20	133.00	26.60	15.96	0.02	0.02	0.76
LS6	Spring	Qdi	Ignimbrite, Tuff	543.00	7.42	0.21	77.00	11.80	144.40	27.36	18.24	0.02	Trace	1.96
LL10	Borehole	Qdp	Pyrocastics	717.00	8.24	0.15	170.00	12.90	32.30	11.40	0.91	0.02	Trace	4.35
LL11	Spring	Qdi	Ignimbrite, Tuff	136.00	6.41	0.21	13.50	4.30	45.60	12.16	3.65	0.10	Trace	0.59
LL12	Spring	Qdi	Ignimbrite, Tuff	188.00	5.83	0.35	15.00	6.80	53.20	11.40	5.93	0.52	Trace	0.80
LL7	Borehole	Qdi	Ignimbrite, Tuff	642.00	7.62	0.16	101.00	15.50	125.40	39.52	6.38	0.01	0.02	2.40
LL8	Spring	Qdi	Ignimbrite, Tuff	612.00	8.08	0.16	100.00	15.00	95.00	30.40	4.56	0.02	Trace	2.34
LL9	Borehole	Qws	Silicica	573.00	7.82	0.31	109.00	12.90	119.70	32.68	9.12	0.08	0.02	1.93
LA1	Borehole	Ql	Lacustrine	2560.00	7.25	2.14	254.00	32.00	912.00	277.40	52.44	0.07	Trace	4.43
LA2	Spring	Qdi	Ignimbrite, Tuff	161.00	6.16	0.39	23.00	9.00	30.40	6.84	3.19	0.56	0.00	0.61
LA3	Borehole	Ql	Lacustrine	1364.00	7.71	0.80	390.00	21.00	30.40	7.60	2.74	0.10	0.00	4.73
LA4	Borehole	Ql	Lacustrine	1033.00	7.63	0.26	190.00	16.50	150.10	27.36	19.61	0.04	0.00	4.44
LA5	Borehole	Qws	Silicica	1127.00	7.48	0.23	202.00	20.50	152.00	32.68	16.87	0.04	Trace	5.21
LA6	Spring	N1_2n	Ignimbrite, Welded tuff	178.00	6.69	0.27	22.50	4.70	43.70	11.40	3.65	0.06	Trace	0.67
LA7	Borehole	NQs	Undivided Sediments	127.00	7.30	0.83	21.50	8.20	9.50	2.28	0.91	0.09	Trace	0.58
B1	Spring	NQs	Undivided Sediments	81.00	6.13	0.12	4.30	2.90	30.40	6.84	3.19	0.05	Trace	0.58
B2	Borehole	NQs	Undivided Sediments	197.00	7.04	0.13	27.00	6.90	45.60	11.40	4.10	0.02	Trace	0.91
B3	Borehole	Qdi	Ignimbrite, Tuff	530.00	8.03	0.14	83.00	3.40	108.30	26.60	10.03	0.14	Trace	1.68
B4	Borehole	Qdi	Ignimbrite, Tuff	689.00	7.81	0.37	76.00	3.90	209.00	54.72	17.33	0.24	Trace	1.00
B5	Borehole	Qdi	Ignimbrite, Tuff	277.00	7.51	0.11	25.50	11.60	81.70	22.80	5.93	0.02	Trace	0.88
B6	Spring	Qvs	Volcanic Sediments	1002.00	7.20	0.19	270.00	17.50	57.00	15.20	4.56	0.01	Trace	10.33
AG1	Borehole	NQs	Undivided Sediments	185.00	6.88	1.35	11.50	5.50	57.00	9.88	7.82	0.21	Trace	1.30
AG2	Spring	Qwbp	Basalt	117.00	5.82	0.52	13.50	2.10	28.50	9.88	0.92	0.57	Trace	0.70
AG4	Spring	NQs	Undivided Sediments	285.00	6.14	0.52	26.50	10.80	76.00	15.20	9.20	0.57	0.02	0.70
AG5	Spring	Pv	Basalt	358.00	6.77	0.19	13.00	4.00	152.00	49.40	6.90	0.02	0.02	0.50
AG6	Spring	Pv	Basalt	349.00	7.28	0.31	12.00	1.10	171.00	50.16	11.04	0.06	0.05	0.30
GID1	Borehole	Qdp	Pyrocastics	308.00	6.61	0.39	28.50	12.50	53.20	12.16	5.47	0.71	Trace	0.56
GID2	Spring	Qdp	Pyrocastics	135.00	5.71	2.26	8.00	6.40	20.90	4.56	2.28	0.30	Trace	0.59
GID3	Borehole	Qdi	Ignimbrite, Tuff	181.00	6.16	0.74	19.00	7.80	43.70	9.12	5.02	0.05	Trace	0.57
GID4	Hand dug well	Qdi	Ignimbrite, Tuff	143.00	5.95	0.30	15.50	6.80	39.90	9.12	4.10	0.16	0.05	0.55
GID5	Borehole	N1_2n	Ignimbrite, Welded tuff	179.00	5.90	0.56	28.00	10.90	7.60	2.28	0.46	0.74	Trace	0.57
GID6	Spring	PNv	Ignimbrite	63.00	5.34	0.72	5.20	1.70	11.40	3.04	0.91	0.56	Trace	0.52
GID7	Borehole	PNv	Ignimbrite	127.00	5.86	0.41	12.00	5.40	34.20	9.12	2.74	0.09	0.05	0.63
GID8	Borehole	NQs	Undivided Sediments	181.00	6.40	0.14	27.00	6.20	45.60	12.90	3.20	0.39	0.00	0.11
KG1	Spring	Pv	Basalt	28.00	5.10	0.31	1.60	0.30	15.20	3.80	1.38	0.54	Trace	0.46
KG2	Spring	Pv	Basalt	70.00	5.67	0.16	4.50	0.80	26.60	8.36	1.38	0.05	0.02	0.39
KG3	Spring	PNv	Ignimbrite	23.00	6.11	0.16	1.40	0.40	95.00	3.04	0.46	0.05	Trace	0.39
KG4	Spring	Pv	Basalt	42.00	5.71	1.35	2.40	1.10	17.10	2.28	2.76	0.21	Trace	1.30
KG5	Borehole	Qa	Alluvium	744.00	6.98	0.48	40.00	4.50	332.60	102.60	18.40	0.04	Trace	0.33
KG6	Spring	Pv	Basalt	697.00	7.35	0.35	57.00	1.10	228.00	72.20	11.40	0.01	Trace	0.77
KG7	Spring	Qwbp	Basalt	343.00	7.21	0.16	13.10	1.80	142.50	42.56	8.66	0.01	Trace	0.54
SC1	Spring	Pv	Basalt	390.00	6.88	0.47	8.80	0.50	199.50	38.76	24.62	0.04	Trace	0.41
SC2	Spring	Qa	Alluvium	979.00	7.76	0.51	148.00	1.30	218.50	52.44	20.98	Trace	Trace	0.56
SC3	Spring	Pv	Basalt	1258.00	6.99	1.06	79.00	2.00	395.20	117.80	24.17	0.01	Trace	0.52
SC4	Borehole	Qa	Alluvium	755.00	8.12	0.14	140.00	4.80	55.10	11.40	6.38	0.02	Trace	0.58
SC5	Borehole	NMT	Basalt	647.00	6.78	0.36	30.78	3.00	323.00	68.40	36.48	Trace	Trace	0.66
SC6	Borehole	NMT	Basalt	486.00	7.27	0.23	21.00	4.90	209.00	49.40	20.52	Trace	Trace	0.59
GEL1	Spring	Pv	Basalt	230.00	6.70	0.09	7.30	2.60	104.50	25.84	9.58	0.08	Trace	0.56
GEL2	Borehole	PNv	Ignimbrite	169.00	6.04	0.09	7.00	0.90	72.20	15.20	8.21	0.08	Trace	0.49
GEL3	Borehole	PNv	Ignimbrite	533.00	7.26	0.34	9.10	2.70	247.00	57.76	24.62	0.03	Trace	0.52
GEL4	Borehole	Pv	Basalt	180.00	6.49	0.09	6.00	1.10	85.50	21.28	7.75	0.06	Trace	0.59
GEL5	Spring	Pcgn4	Gneiss	822.00	7.40	0.98	42.00	2.30	351.50	90.44	30.10	0.04	0.02	0.51
GEL6	Spring	Pv	Basalt	369.00	7.41	0.16	24.00	3.10	150.10	38.76	12.77	0.02	Trace	0.51
BW1	Spring	Pv	Basalt	139.00	6.59	0.44	10.50	2.00	45.60	11.40	4.10	0.04	Trace	0.60
BW2	Spring	Pv	Basalt	41.00	6.73	0.31	3.50	2.80	9.50	1.52	1.37	0.04	Trace	0.54
BW3	Borehole	Pcgn4	Gneiss	1039.00	7.11	0.88	127.00	10.00	285.00	66.88	28.27	58.50	Trace	0.84
BW4	Spring	Pcgn3	Gneiss	155.00	6.46	0.15	10.00	1.70	57.00	16.72	3.65	0.08	Trace	0.56
BW5	Borehole	NPv	Basalt	588.00	6.91	0.30	36.00	1.20	248.90	57.00	25.54	0.01	0.05	0.74
BW6	Borehole	Pv	Basalt	973.00	6.96	0.42	40.00	5.10	408.50	95.00	41.04	0.01	Trace	0.74
BW7	Borehole	QHR	Fulvialite	2890.00	8.30	0.15	590.00	5.70	19.00	3.80	2.28	0.02	Trace	3.54
KL1	Borehole	Qa	Alluvium	638.00	8.15	0.28	138.00	2.40	38.00	7.60	4.56	0.20	0.05	0.50
KL2	Borehole	Pcgn1	Gneiss	1450.00	8.05	2.52	19.50	4.80	712.50	106.40	107.16	0.01	Trace	0.57
KL3	Borehole	NMT	Basalt	1611.00	6.95	1.25	66.50	5.50	627.00	148.20	61.56	0.02	Trace	0.65
KL4	Borehole	Pcgt4	Granite	392.00	6.91	0.21	26.50	2.10	142.50	38.00	11.40	0.11	0.02	0.58
KL5	Borehole	Pcgn1	Gneiss	680.00	7.34	0.60	37.00	2.30	285.00	75.24	23.26	0.63	0.02	0.69
KL6	Borehole	NMT	Basalt	1453.00	7.51	0.59	276.00	7.10	218.50	44.84	25.54	0.05	Trace	0.88
S1	Spring	NMT	Basalt	171.00	6.74	0.09	10.50	3.30	66.50	15.96	6.38	0.05	Trace	0.80
S2	Borehole	Qe	Ellivium	1191.00	7.38	0.51	196.00	7.40	271.70	76.00	19.61	Trace	0.05	1.14
S3	Borehole	Qe	Ellivium	571.00	6.62	0.14	41.00	2.10	228.00	58.52	19.61	0.06	Trace	0.75
S4	Borehole	Pcgn4	Gneiss	1592.00	6.41	1.01	92.00	5.40						

Data 3.5 Water Quality Analysis Results (Laboratory Measurement), (3/3)

CLIENTS ID.NO.	SOURCE OF SAMPLE	AQUIFER	ROCK FACIES	Chloride (mg/l Cl)	Nitrite (mg/l NO2)	Nitrate (mg/l NO3)	Alkalinity (mg/l CaCO3)	Carbonate (mg/l CO3)	Bicarbonate (mg/l HCO3)	Sulphate (mg/l SO4)	Phosphate (mg/l PO4)	Total Coliform Per 100 ml	Fecal Coliform Per 100 ml
WZA1	Borehole	Qwbh	Basalt flow	1.82	Trace	2.19	73.50	Nil	89.67	Trace	0.39	-	-
WZA2	Borehole	N1_2n	Ignimbrite, Welded tuff	1.82	0.10	6.91	231.00	Nil	281.82	Trace	0.58	-	-
WZA3	Borehole	Qwbh	Basalt flow	0.91	0.01	7.34	210.00	Nil	256.20	Trace	0.64	-	-
WZA4	Borehole	Qdi	Ignimbrite, Tuff	6.37	0.04	23.46	252.00	Nil	307.44	0.57	0.70	-	-
WZA5	Borehole	Qdi	Ignimbrite, Tuff	14.56	0.28	3.41	430.50	25.20	473.97	Trace	0.51	-	-
WZA6	Borehole	Qdi	Ignimbrite, Tuff	5.46	Trace	3.19	399.00	Nil	486.78	Trace	0.49	-	-
WZA7	Borehole	Ql	Lacustrine	19.11	0.06	0.45	514.50	37.80	550.83	Trace	0.68	-	-
EZ1	Borehole	Ql	Lacustrine	10.01	0.02	1.07	619.50	Nil	755.79	4.00	0.87	-	-
EZ2	Spring	Ql	Lacustrine	0.91	0.01	1.23	214.20	Nil	261.32	0.10	0.56	-	-
EZ3	Spring	Ql	Lacustrine	7.28	0.01	4.06	121.80	Nil	148.60	2.19	0.46	-	-
EZ4	Borehole	Ql	Lacustrine	5.46	Trace	1.40	546.00	22.68	620.00	67.69	0.83	-	-
EZ5	Borehole	Qwbh	Basalt flow	0.91	Trace	0.71	201.60	Nil	245.95	0.48	0.79	-	-
EZ6	Spring	Qwbh	Basalt flow	1.82	Trace	1.29	157.50	Nil	192.15	0.29	0.49	-	-
EZ7	Borehole	Ql	Lacustrine	29.12	Trace	0.70	350.70	Nil	427.85	6.00	0.56	-	-
LS1	Spring	Qdi	Ignimbrite, Tuff	2.73	Trace	4.73	37.80	Nil	46.12	0.86	0.14	-	-
LS2	Spring	Qwpu	Pumice tuff, Tuff	2.73	Trace	1.45	199.50	Nil	243.39	Trace	0.14	-	-
LS3	Borehole	Qdi	Ignimbrite, Tuff	1.82	Trace	11.64	212.10	Nil	258.76	0.19	0.26	-	-
LS4	Spring	NQs	Undivided Sediments	0.91	Trace	2.97	84.00	Nil	102.48	0.19	0.23	-	-
LS5	Borehole	N1_2n	Ignimbrite, Welded tuff	4.55	Trace	6.22	247.80	Nil	302.32	0.19	0.56	-	-
LS6	Spring	Qdi	Ignimbrite, Tuff	5.46	Trace	12.31	304.50	Nil	371.49	0.10	0.52	-	-
LL10	Borehole	Qdp	Pyrocrastics	16.38	Trace	10.95	336.00	35.28	338.18	3.14	0.56	-	-
LL11	Spring	Qdi	Ignimbrite, Tuff	2.73	Trace	28.43	46.20	Nil	56.36	0.57	0.65	-	-
LL12	Spring	Qdi	Ignimbrite, Tuff	1.82	0.01	14.03	73.50	Nil	89.67	3.90	0.46	-	-
LL7	Borehole	Qdi	Ignimbrite, Tuff	2.73	Trace	2.01	373.80	Nil	456.04	Trace	0.58	-	-
LL8	Spring	Qdi	Ignimbrite, Tuff	4.55	Trace	1.05	304.50	Nil	371.49	Trace	0.56	-	-
LL9	Borehole	Qws	Silicica	5.46	Trace	0.80	325.50	Nil	397.11	Trace	0.51	-	-
LA1	Borehole	Ql	Lacustrine	32.76	0.01	0.54	487.20	Nil	594.38	968.18	0.58	-	-
LA2	Spring	Qdi	Ignimbrite, Tuff	1.82	0.06	0.94	84.00	Nil	102.48	5.62	0.79	-	-
LA3	Borehole	Ql	Lacustrine	32.76	0.10	50.96	735.00	Nil	896.70	5.71	1.17	-	-
LA4	Borehole	Ql	Lacustrine	30.94	0.06	10.37	525.00	Nil	640.50	25.70	0.82	-	-
LA5	Borehole	Qws	Silicica	53.70	0.05	14.76	493.50	Nil	602.07	71.88	0.81	-	-
LA6	Spring	N1_2n	Ignimbrite, Welded tuff	2.73	0.02	8.43	84.00	Nil	102.48	3.24	0.74	-	-
LA7	Borehole	NQs	Undivided Sediments	2.73	0.01	0.76	63.00	Nil	76.86	1.14	0.27	-	-
B1	spring	NQs	Undivided Sediments	1.82	Trace	12.35	23.10	Nil	28.18	2.19	0.40	-	-
B2	Borehole	NQs	Undivided Sediments	Trace	Trace	2.12	105.00	Nil	128.10	0.10	0.59	-	-
B3	Borehole	Qdi	Ignimbrite, Tuff	4.55	Trace	1.45	304.50	Nil	371.49	0.10	0.58	-	-
B4	Borehole	Qdi	Ignimbrite, Tuff	Trace	Trace	1.87	399.00	Nil	486.78	0.76	0.53	-	-
B5	Borehole	Qdi	Ignimbrite, Tuff	1.82	Trace	14.76	142.80	Nil	174.22	4.09	0.49	-	-
B6	spring	Qvs	Volcanic Sediments	22.75	0.02	4.50	516.60	Nil	630.25	31.42	0.20	-	-
AG1	Borehole	NQs	Undivided Sediments	5.40	0.02	4.41	73.50	Nil	89.67	0.03	0.15	-	-
AG2	Spring	Qwbp	Basalt	0.90	0.02	29.26	25.20	Nil	30.74	3.24	0.21	-	-
AG4	Spring	NQs	Undivided Sediments	11.70	0.13	29.26	88.20	Nil	107.60	3.24	0.21	-	-
AG5	Spring	Pv	Basalt	17.10	0.02	13.80	136.50	Nil	166.53	0.48	0.38	-	-
AG6	Spring	Pv	Basalt	6.30	Trace	1.98	199.50	Nil	243.40	0.38	0.27	-	-
GID1	Borehole	Qdp	Pyrocrastics	4.55	0.02	30.35	73.50	Nil	89.67	13.23	0.90	-	-
GID2	Spring	Qdp	Pyrocrastics	2.73	0.02	28.43	50.40	Nil	61.49	2.95	0.83	-	-
GID3	Borehole	Qdi	Ignimbrite, Tuff	1.82	0.01	9.21	84.00	Nil	102.48	Trace	1.32	-	-
GID4	Hand dug well	Qdi	Ignimbrite, Tuff	1.82	Trace	22.01	52.50	Nil	64.05	3.43	0.53	-	-
GID5	Borehole	N1_2n	Ignimbrite, Welded tuff	10.01	0.02	13.13	58.80	Nil	71.74	2.38	0.67	-	-
GID6	Spring	PNv	Ignimbrite	0.91	0.04	16.73	8.40	Nil	10.25	3.90	0.68	-	-
GID7	Borehole	PNv	Ignimbrite	Trace	0.01	3.75	63.00	Nil	76.86	1.33	0.64	-	-
GID8	Borehole	NQs	Undivided Sediments	6.60	0.01	6.33	90.30	-	110.20	1.71	0.39	-	-
KG1	Spring	Pv	Basalt	1.80	0.07	4.60	6.30	Nil	7.69	3.40	0.09	-	-
KG2	Spring	Pv	Basalt	5.40	0.01	5.80	21.00	Nil	25.80	0.07	0.12	-	-
KG3	Spring	PNv	Ignimbrite	0.90	0.05	5.80	4.20	Nil	5.12	0.76	0.12	-	-
KG4	Spring	Pv	Basalt	1.80	0.05	4.41	10.50	Nil	12.81	1.70	0.15	-	-
KG5	Borehole	Qa	Alluvium	5.40	0.20	15.80	405.30	Nil	494.50	14.80	0.52	-	-
KG6	Spring	Pv	Basalt	17.29	0.02	0.36	352.80	Nil	430.42	1.24	1.71	-	-
KG7	Spring	Qwbp	Basalt	1.82	Trace	8.30	174.30	Nil	212.65	0.19	0.19	-	-
SC1	Spring	Pv	Basalt	5.46	0.01	0.36	231.00	Nil	281.82	1.43	0.36	-	-
SC2	Spring	Qa	Alluvium	18.20	0.01	0.27	546.00	Nil	666.12	0.38	0.11	-	-
SC3	Spring	Pv	Basalt	132.87	0.04	14.34	420.00	Nil	512.40	5.24	0.13	-	-
SC4	Borehole	Qa	Alluvium	69.17	0.01	0.51	262.50	Nil	320.25	40.46	0.21	-	-
SC5	Borehole	NMt	Basalt	11.83	0.02	0.47	399.00	Nil	486.78	1.33	0.26	-	-
SC6	Borehole	NMt	Basalt	10.01	Trace	1.34	262.50	Nil	320.25	0.29	0.15	-	-
GEL1	Spring	Pv	Basalt	4.55	Trace	11.73	109.20	Nil	133.22	0.10	0.11	-	-
GEL2	Borehole	PNv	Ignimbrite	5.46	Trace	21.14	69.30	Nil	84.55	0.10	0.07	-	-
GEL3	Borehole	PNv	Ignimbrite	16.38	Trace	28.01	220.50	Nil	269.01	Trace	0.06	-	-
GEL4	Borehole	Pv	Basalt	2.73	Trace	2.30	94.50	Nil	115.29	0.10	0.05	-	-
GEL5	Spring	Pcgn4	Gneiss	10.01	0.10	6.73	430.50	Nil	525.21	39.03	0.09	-	-
GEL6	Spring	Pv	Basalt	9.10	Trace	1.29	168.00	Nil	204.96	21.52	0.10	-	-
BW1	Spring	Pv	Basalt	Trace	0.01	3.03	69.30	Nil	84.55	2.28	0.72	-	-
BW2	Spring	Pv	Basalt	Trace	0.01	3.41	12.60	Nil	15.37	Trace	3.44	-	-
BW3	Borehole	Pcgn4	Gneiss	31.85	0.01	7.02	472.50	Nil	576.45	107.10	0.59	-	-
BW4	Spring	Pcgn3	Gneiss	1.82	0.02	0.29	84.00	Nil	102.48	0.29	0.03	-	-
BW5	Borehole	NPv	Basalt	10.01	0.01	2.79	315.00	Nil	384.30	13.80	0.03	-	-
BW6	Borehole	Pv	Basalt	40.95	Trace	5.93	485.10	Nil	591.82	0.67	0.09	-	-
BW7	Borehole	QHR	Fulviate	96.47	0.01	4.79	777.00	27.72	891.58	489.80	0.26	-	-
KL1	Borehole	Qa	Alluvium	20.02	0.01	3.21	294.00	Nil	358.68	37.98	0.83	-	-
KL2	Borehole	Pcgn1	Gneiss	146.52	Trace	127.78	462.00	Nil	563.64	10.28	0.26	-	-
KL3	Borehole	NMt	Basalt	114.67	0.01	73.59	630.00	Nil	768.60	1.33	0.17	-	-
KL4	Borehole	Pcgt4	Granite	14.56	Trace	44.22	159.60	Nil	194.71	5.05	0.53	-	-
KL5	Borehole	Pcgn1	Gneiss	10.01	Trace	6.33	367.50	Nil	448.35	0.86	0.41	-	-
KL6	Borehole	NMt	Basalt	34.58	Trace	4.21	829.50	Nil	1011.99	17.14	0.46	-	-
S1	Spring	NMt	Basalt	1.82	Trace	0.94	67.20	Nil	81.98	18.94	0.10	-	-
S2	Borehole	Qe	Ellivium	44.59	0.14	1.47	583.80	Nil	712.24	96.44	0.39	-	-
S3	Borehole	Qe	Ellivium	37.31	Trace	15.14	235.20	Nil	286.94	0.19	0.08	-	-
S4	Borehole	Pcgn4	Gneiss	143.79	0.08	120.98	399.00	Nil	486.78	51.31	0.06	-	-
S5	Spring	Pv	Basalt	5.46	Trace	10.66	373.80	Nil	456.04	1.43	0.17	-	-
S6	Borehole	NMt	Basalt	41.86	Trace	43.15	483.00	Nil	589.26	0.10	0.14	-	-
RVS BH-1	Borehole	-	Sand, Gravel, Pumice	15.1	0.01	1	273	-	333.1	4	0.4	-	-
RVS BH-2	Borehole	-	Sand, Gravel, Tuff	13.65	0.01	2.39	289.8	Nil	353.56	0.86	0.23	-	-
RVS BH-3	Borehole	-	Tuff breccia	12.7412727	0.005	0.6244	197.6	Nil	241.072	10.5672	0.9243	-	-
RVS BH-4	Borehole	-	Welded tuff, Basalt	5.68	Trace	1.71	285	Nil	347.7	53.94	0.55	-	-
RVS BH-5N	Borehole	-	Basalt	11.36	Trace	0.13	216.6	Nil	264.25	25.06	0.32	-	-
RVS BH-6	Borehole	-	Welded tuff, Sand, Gravel	24.61	Trace	15.48	266	Nil	324.52	100.22	0.24	-	-
RVS BH-7	Borehole	-	Sand, Gravel	5.68	Trace	0.42	184.3	22.8	178.49	0.35	0.29	-	-
RVS BH-8	Borehole	-	Sand, Gravel	53	0.01	13.56	408.5	Nil	498.37	21.23	0.27	-	-
RVS BH-9N	Borehole	-	Volcanic sand	13.25	0.01	0.91	256.5	91.2	127.49	0.35	0.53	-	-
RVS BH-10N	Borehole	-	Welded tuff	1.89	0.01	0.91	152	Nil	185.44	0.35	0.17	-	-

Data 3.6 Isotope Analysis Result (1/2)

Code	Basin ID	Aquifer ID		d ² H (d D)	d ¹⁸ O
WZA-1	1	1C	3	-3.39	-2.55
WZA-2	1	2B	5	-22.52	-4.74
WZA-3	1	1C	3	-2.89	-1.98
WZA-4	1	1C	3	-4.15	-2.48
WZA-5	1	1C	3	-19.63	-3.86
WZA-6	1	1C	3	-27.72	-5.21
WZA-7	1	1B	2	-16.09	-4.52
EZ-1	2	1B	2	3.17	-2.02
EZ-2	2	1B	2	-1.59	-1.61
EZ-3	2	1B	2	1.32	-1.01
EZ-4	2	2B	5	1.22	-1.19
EZ-5	2	1C	3	3.26	-0.93
EZ-6	2	1C	3	5.19	-0.88
EZ-7	2	1B	2	5.93	-0.92
LS-1	3	1C	3	6.26	-1.11
LS-2	3	1C	3	-9.81	-3
LS-3	3	1C	3	-3.18	-2.12
LS-4	3	1C	3	-17.92	-4.5
LS-5	3	2B	5	24.53	4.66
LS-6	3	1C	3	6.15	-2.51
LL-10	4	1C	3	-1.11	-1.34
LL-11	4	1C	3	-1.59	-1.61
LL-12	4	1C	3	-6.7	-1.93
LL-7	4	1C	3	0.04	-2.04
LL-8	4	1C	3	5.28	-0.38
LL-9	4	1C	3	0.97	-1.39
LA-1	5	1B	2	10.71	-0.28
LA-2	5	1C	3	3.29	-2.02
LA-3	5	1B	2	22.64	2.09
LA-4	5	1B	2	3.32	-1.47
LA-5	5	1C	3	5.32	-0.81
LA-6	5	2B	5	-0.74	-2.48
LA-7	5	1C	3	2.28	-1.98
B-1 June 16/10	6	1C	3	10.11	-1.87
B-2 June 16/10	6	1C	3	1.99	-2.55
B-3	6	1C	3	-7.56	-2.51
B-4	6	1C	3	-0.94	-0.99
B-5	6	1C	3	-2.9	-1.38
B-6 June 09/10	6	1C	3	-15.23	-3.48
AG-1	7	1C	3	0.83	-2.55
AG-2	7	1C	3	1.35	-2.54
AG-4	7	1C	3	4.58	-1.76
AG-5	7	2B	5	3.5	-1.99
AG-6	7	2B	5	2.3	-1.83
GID-1	8	1C	3	4.07	-2.31
GID-2	8	1C	3	4.07	-0.14
GID-3	8	1C	3	5.03	-0.16
GID-4	8	1C	3	5.01	-0.14
GID-5	8	2B	5	5.05	-0.15
GID-6	8	2B	5	5.02	-0.13
GID-7	8	2B	5	5.96	-1.05
(GID-8)Ag-3	7	1C	3	4.31	-1.04

Data 3.6 Isotope Analysis Result (2/2)

Code	Basin ID	Aquifer ID		d ² H (d D)	d ¹⁸ O
KG-1	9	2B	5	-8.49	-2.7
KG-2	9	2B	5	-5.18	-2.42
KG-3	9	2B	5	-2.89	-2.34
KG-4	9	2B	5	-3.23	-2.62
KG-5	9	1A	1	1.96	-1.42
KG-6	9	2B	5	4.07	-2.31
KG-7	9	1C	3	-0.42	-2.3
SC-1	10	2B	5	-0.71	-1.05
SC-2	10	1A	1	1.05	-1.27
SC-3	10	2B	5	-4.74	-2.21
SC-4	10	1A	1	-3.78	-1.27
SC-5	10	2B	5	-1.85	-1.27
SC-6	10	2B	5	-2.81	-1.27
GEL-1	11	2B	5	-1.6	-2.6
GEL-2	11	2B	5	1.43	-1.89
GEL-3	11	2B	5	2.03	-1.79
GEL-4	11	2B	5	-3.16	-2.64
GEL-5	11	2C	6	-6.07	-1.59
GEL-6	11	2B	5	-3.7	-1.2
BW-1	12	2B	5	0.5	-2.31
BW-2	12	2B	5	-4.33	-2.93
BW-3	12	2C	6	0.68	-1.83
BW-4	12	2C	6	-2.29	-2.6
BW-5	12	2B	5	-1.31	-2.45
BW-6	12	2B	5	-4.01	-2.31
BW-7	12	1A	1	2.27	-2.32
KL-1	13	1A	1	-9.29	-4.81
KL-2	13	2C	6	-3.57	-1.04
KL-3	13	2B	5	-2.62	-1.05
KL-4	13	2C	6	-3.82	-1.46
KL-5	13	2C	6	2.09	-0.92
KL-6	13	2B	5	-6.78	-2.94
S-1	14	2B	5	-4.43	-2.2
S-2	14	1B	2	-1.72	-2.05
S-3	14	1B	2	-2.34	-1.99
S-4	14	2C	6	29.21	5.04
S-5	14	2B	5	5.69	0.26
S-6	14	2B	5	3.27	-0.84
RVBH-1	6	1C	3	-2.44	-6.82
RVBH-2	8	1C	3	-2.17	-2.81
RVBH-3	3	1C	3	-2.59	-6.53
RVBH-4	8	1C	3	-14.10	-3.19
RVBH-5	6	2B	5	-21.47	-5.12
RVBH-6	3	2B	5	-30.30	-5.89
RVBH-7	9	2B	5	-23.38	-5.83
RVBH-8	10	2B	5	-13.50	-5.07
RVBH-9N	4	2B	5	-10.05	-4.30
RVBH-10N	2	2B	5	-19.04	-5.23

THE FEDERAL DEMOCRATIC REPUBLIC OF **ETHIOPIA**
MINISTRY OF WATER RESOURCES

SPECIFICATION FOR ETHIOPIAN DRINKING WATER QUALITY GUIDELINES

*September 2002
Addis Ababa*

PREFACE

The development of tailor made national water quality guideline is necessary to promote and protect the public health, prevent and control diseases as well as to address the water quality concerns of the country. This guideline is developed on the basis of latest publications of WHO Guidelines for Drinking Water Quality Volumes- 1, 2, 3 and Addendum of volume-1 and taking into consideration a variety of local factors such as geographical, socio-economic and environmental conditions.

It is believed that this guideline is used as Ethiopian Drinking Water Quality Guideline encompassing recommendations for water quality requirement that will be fit for human consumption and other domestic purposes as well as water quality monitoring.

This guideline is dynamic and has to be improved and updated with new findings and developments in the field. Therefore, constructive comments and suggestions are always welcome.

1.0 SCOPE

This tailor made guideline value, developed on the principles of risk-benefit approach or acceptable risk, represents the concentration of the constituents that does not result in any significant risk to the health of the consumer over the Ethiopian lifetime of consumption.

2.0 APPLICATION

This guideline applies to microbiological, physical, chemical, radiological quality of drinking water. It is relevant to all domestic water uses such as drinking, food preparation and personal hygiene.

3.0 REQUIREMENTS

The basic quality requirements for drinking water are illustrated as follows: -

- 3.1 The drinking water shall be free from any diseases causing pathogenic organisms and concentration of toxic chemical compounds that have adverse effect on human health (as prescribed in Tables-1, 2 and 5).
- 3.2 The drinking water shall be fairly clear (i.e., of low turbidity and color) and contain no compounds that cause offensive taste and odor and free of substances and organisms that cause corrosion or encrustation of water supply system as presented in Table-3.
- 3.3 When the guideline values are exceeded, it should only be a signal to investigate and take remedial action. Short-term exposure, however, does not necessarily mean that the water is unsuitable for consumption. The amount by which, and the period for which, the guideline value can be exceeded without affecting public health depends upon the specific substance involved and its concentration.

A continuous effort should be made to maintain drinking water quality at the highest possible level. Although the guideline value recommends the quality of water acceptable for consumption, it does not imply that the quality of drinking water should be degraded to the recommended level.

All desirable parameters and substances should be examined whenever a doubt arises. When a new water supply source develops it has to be examined before any supply.

In order to keep the uniformity of measurement results units of microbiological quality, physical parameters, chemical constituents and radioactive substances should be the same as presented in Tables-1, 2,3,4 and 5.

Table-1 Bacteriological Quality

No.	Substance	Guideline Value (G _N)	Remark
A Treated Water Entering the Distribution System			
1	<i>E.coli</i> or thermo tolerant Coliform bacteria	0/100 ml	Membrane filtration is recommended for low turbid water
2	Total Coliform Bacteria	0/100 ml	93.0 % of samples examined throughout the year
B Treated Water In the Distribution System			
1	<i>E.coli</i> or thermo tolerant Coliform bacteria	0/100 ml	Membrane filtration is recommended for low turbid water
2	Total Coliform Bacteria	0/100 ml	93.0 % of samples examined throughout the year

Table-2 Chemicals of Health Significance

No.	Substance	Guideline (G _s) (mg/l)	Remark (Health Effect)
A Inorganic Constituents			
1	Arsenic	0.01 (P)	High incidence of skin & possibly other cancers
2	Barium	1.8	Increase blood pressure & suspect of cardiovascular diseases
3	Boron	0.3	Long-term exposure leads to gastrointestinal irritation
4	Cadmium	0.003	Kidney is the main target organ of toxicity
5	Chromium	0.10	Carcinogenicity suspect of chromium (VI) compounds
6	Copper	5	Acute gastric irritation & liver cirrhosis from long-term exposure
7	Cyanide	0.07	Acute toxicity is high. Effects on thyroid & particularly the nervous system on long-term exposure occurred.
8	Fluoride	3.0	At low conc. prevent dental carries. At high conc. increase risk of dental fluorosis, & much higher conc. leads to skeletal fluorosis.
9	Lead	0.02	Toxic to both the central & peripheral nervous systems, including subencephalopathic neurological effects.
10	Manganese	0.8	Neurotoxicity and other toxic effects
11	Mercury (total)	0.001	The kidney is the main target for inorganic Hg, whereas methyl-mercury affects mainly the central nervous system.
12	Nitrate (as NO ₃)	50	Causes methaemoglobinaemia in infants and suspect of certain form of cancer risk
13	Nitrite (as NO ₂)	6.0	" " " "
14	Selenium	0.01	Long-term exposure cause toxic effect on nails, hairs and liver.
B Organic Constituents			
B1	Aromatic hydrocarbons	($\mu\text{g/l}$)	
1	Benzene	10	Acute exposure at high conc. affects the central nervous system. At lower conc. it is toxic to haematopoietic system. Carcinogenic to humans (Group-1)
2	Benzo[a]pyrene	0.7	It causes cancer and induces tumors at the site of administration.
B2	Chlorinated alkanes		
1	Carbon tetrachloride	2	Possibly carcinogenic to humans (Group-2B)
2	1,2-dichloroethane	30	Possibly carcinogenic to humans (Group-2B)
B3	Chlorinated ethenes		
1	1,1-Dichloroethene	30	Potentially carcinogenic (Group-3)
2	Trichloroethene	70(P)	Potentially carcinogenic (Group-3)
3	Tetrachloroethene	40	Possibly carcinogenic to humans (Group-2B)

Table-2 (Cont.)

No.	Substance	Guideline (G _N) (mg/l)	Remark (Health Effect)
C Pesticides			
		(μ g/l)	Remark (Health Effect)
1	DDT	2	Possibly carcinogenic to humans (Group-2B)
2	Aldrine,Deldrine	0.03	Potentially carcinogenic (Group-3)
3	Chlordane	0.2	Possibly carcinogenic to humans (Group-2B)
4	Pentachlorophenols	9 (P)	Potentially carcinogenic to lab animals.
5	2,4-D	30	Possibly carcinogenic to humans (Group-2B)
D Disinfectant & Disinfectant By-products			
D1	Disinfectant	(mg/l)	Remark (Health Effect)
1	Chlorine	5	<ul style="list-style-type: none"> For effective chlorination, free residual chlorine 0.5 mg/l after 30 min of contact time & pH<8 Potentially carcinogenic (Group-3)
D2	Disinfectant By-products	(μ g/l)	
D2.1	Chlorophenol		
1	2,4,6-Trichlorophenol	200	Possibly carcinogenic to humans (Group-2B)
D2.2	trihalomethane		
1	Chloroform	200	Possibly carcinogenic to humans (Group-2B)

- P - Provisional guideline value (see WHO, Vol-1, p178)
- Group - is the IARC classification (see WHO, Vol-1, p35)
- The sum of the ratio of the concentration of (NO₃ & NO₂ to its respective guideline values should not exceed 1.

Table-3 Substances and Parameters that may Give Rise to Complaints from Consumers

No.	Substance	Guideline Value (G _N) (mg/l)	Remark (Adverse Effect)
A Physical Parameters			
1	True Color	22	Unpleasant appearance
2	Odor	Non-Objectionable	Unappealing to drink
3	Taste	Non-Objectionable	Unappealing to drink
4	Temperature	Non-Objectionable	High temperature may enhance growth of micro organisms & may increase taste, odor, color & corrosion
5	Turbidity	7	Stimulate after growth & cause objectionable appearance
B Inorganic Constituents			
1	Aluminum	0.4	Deposition of aluminum hydroxide flocks in pipes & exacerbation of discoloration of water by iron
2	Ammonia	2	Objectionable odor
3	Chloride	533	Undesirable taste
4	Copper	2	Increase corrosion of GI & steel fittings, staining laundry & sanitary ware and give rise taste problem.
5	Hardness	392*	Based on 300 as Reference WHO recommendation
6	Hydrogen Sulfide	0.07	Objectionable rotten egg odour
7	Iron	0.4	Cause reddish-brown color, promote iron-bacteria & stain laundry & plumbing fixtures
8	Manganese	0.13	Stain laundry & plumbing fixtures and give rise to undesirable taste to beverages. Deposited as black precipitate in pipes. Certain micro organisms concentrate to give taste, odor, & turbidity problem.
9	Dissolved Oxygen	-	Low DO encourage for anaerobic reaction & formation of NO ₂ , H ₂ S giving rise to odor. It also increase Fe(II).
10	pH	6.5 – 8.5	High pH imparts taste & soapy feel, while low pH cause corrosion. Preferably <8.0 for effective disinfection
11	Sodium	358	Undesirable taste
12	Sulfate	483	Causes noticeable taste & corrosion of pipes
13	TDS	1776	Undesirable taste
14	Zinc	6	Imparts astringent taste & opalescent and develop a greasy film on boiling.
B Disinfectants & Disinfectant by-products			
	Disinfectants	(μ g/l)	
1	Chlorine	500 – 1000	Taste and odour problem

* There is no as such any Guideline figure set by WHO. However the maximum recommended value of 300 is taken for calculation.

Table-4 Chemicals not of Health Significance at Concentration Normally Found in Drinking Water

No.	Substance	Guideline Value (G _N)	Remark
1	Asbestos		U
2	Silver		U
3	Tin		U

U - It is unnecessary to recommend a health-based guideline value, because they are not hazardous to human health at concentrations normally found in drinking water.

Table-5 Radioactive Constituents of Drinking Water

No.	Substance	Screening Value (Bq/litre)	Remark (Health Effect)
1	Gross alpha activity	0.1	<ul style="list-style-type: none"> If a screening value exceeded, more detail radionuclide analysis is necessary. WHO & other countries' is the same value. The main concern is Cancer
2	Gross beta activity	1	

4.0 SAMPLING TECHNIQUE

The detail procedure for preservation and handling of samples is presented in WHO, Vol-3 chapter-4 and ISO Water- Sampling- Part 3: Reference No. 5667-3:1994(E).

4.1 General Requirement For Bacteriological Sampling

Sampling for bacteriological examination should be carried out using sterile container of glass or polyethylene. Samples should be preserved under low temperature of 2 to 5 °C during storage and transport. The time between sampling and analysis should not exceed 6 hours, and 24 hours is considered the absolute maximum. If ice is not available, the transport time must not exceed 2 hours.

The bacteriological test should be accompanied with turbidity and free residual chlorine and pH where chlorination is applied. The minimum recommended frequency of sampling and analysis for on spot and piped distribution water supply schemes are given in Table-6 and Table-7 respectively.

Table-6 Minimum Frequency of Sampling and Analysis of On-spot Distribution Water Schemes

Sources & Mode of supply	Minimum frequency of sampling & Analysis		Remarks
	Bacteriological	Physico-chemical	
HDW & shallow well with HP	Sanitary protection Bacteriological test only if situation demands	Once initially, thereafter as situation demands	The situation requiring testing are change in environmental conditions, outbreak of water born diseases, or increase in incidents of water born diseases
BH-with HP	Once initially, thereafter as situation demands	Once initially, thereafter as situation demands	Ditto
Protected spring	Once initially, thereafter as situation demands	Periodically for residual chlorine if water is chlorinated	Ditto

BH = Borehole, HDW = Hand-dug-well, HP = Hand-pump

Table-7 Minimum Sample Numbers for Piped Drinking Water in the Distribution System

Group	Pop served	No of Annual samples
1	<5000	2
2	5000-100,000	(Pop/5000) x 5
3	>100,000	(Pop/ 10,000) + 120

4.2 General Requirement for Physico-Chemical Sampling

In general samples for physico-chemical analysis are recommended to be stored in a clean glass or polyethylene bottles at a low temperature in the dark (see Table-8). It is essential that the container should not be a cause of contamination and absorb or adsorb the constituents to be determined.

Table-8 Allocation of Physico-chemical Parameters (of interest) to the Type of Preservation

No.	Preservation by	Suitable for	Not Suitable for	Remarks
1	Acidification to pH<2	Alkali metals Aluminum Ammonia Arsenic Alkali earth metal Nitrate Total hardness Phosphorus, total Heavy metal	Cyanide Sulfides Carbonates, bicarbonates, CO2 Nitrites	Don't use sulfuric acid for Calcium and lead. Don't use hydrochloric acid for silver, lead and mercury. Don't use nitric acid for tin.
2	Cooling to 2°C to 5°C	Alkalinity Ammonia Conductivity Nitrate Nitrite Odour Orthophosphates Sulfates Total residue		

Every newly developed source has to be tested for full physico-chemical analysis before any service. Then after, the sampling for piped system should be carried out in such a way that one sample should be taken every two years for ground water sources such as borehole, shallow-tube-well and spring.

Surface water intended for water supply source should be sampled at least 6 times per year per site to detect the maximum and minimum concentration of interest. Then after two full physico-chemical analyses per year is recommended.

In all water sources when situation demands testing should be done for important parameters. These special situations are change in environmental condition, outbreak of water born diseases or increase of water born diseases.

4.3 Identification and Records

The source of the sample and the conditions under which it was collected should be recorded and attached to the bottle immediately after filling. At least the following information should be included with the sample (See Figure-1).

Figure-1 Suggested Form to Accompany Water Samples

Water-quality monitoring program	
SAMPLING DATA	
1	Region
2	Zone
3	Wereda
4	Town/Village
5	Sampling site
6	Source
7	Nature of sample (Treated or non-treated)
8	Residual chlorine
9	Date of sampling
10	Time of sampling
11	Sampled by (Organization)

5.0 TESTING METHODS

The following test methods are selected mainly from ISO (International Organization for Standardization), based on WHO recommendation, to serve as reference test methods, in which every water quality laboratory in the country should develop towards it (see Table-9 to Table-13). International Organization for Standardization (ISO) is a worldwide federation of national standards bodies (ISO member bodies).

Table-9 Bacteriological Quality of Drinking Water

1	SUBSTANCE	REFERENCE	TEST METHOD
1	<i>E.coli</i> or thermo-tolerant Coliform bacteria	ISO 9308-1:1990 or	Determination & enumeration of coliform organisms, thermo-tolerant coliform organisms and presumptive <i>escherchia coli</i> – Part 1: Membrane filtration method
		ISO 9308-2:1990	Determination & enumeration of coliform organisms, thermo-tolerant coliform organisms and presumptive <i>escherchia coli</i> – Part 2: Multiple Tube (MPN) method
2	Total Coliform bacteria	ISO 9308-1:1990 or	Determination & enumeration of coliform organisms, thermo-tolerant coliform organisms and presumptive <i>escherchia coli</i> – Part 1: Membrane filtration method
		ISO 9308-2:1990	Determination & enumeration of coliform organisms, thermo-tolerant coliform organisms and presumptive <i>escherchia coli</i> – Part 2: Multiple Tube (MPN) method

- Membrane filtration is recommended for low turbidity water

Table-10 Substances and Parameters that May Give Rise to Complaints from Consumers

	SUBSTANCE	REFERENCE	TEST METHOD
A	Physical Parameters		
1	True Color	ISO 7887:1984(E)	Examination and Determination of Color
2	Odor	WHO, Vol-2, p358	Panel evaluation
3	Taste	WHO, Vol-2, p358	Panel evaluation
4	Turbidity	ISO 7027:1990(E)	Determination of Turbidity
B	Inorganic constituents		
1	Aluminum	ISO 12020:1997(E)	Determination of Aluminum AAS method
2	Ammonia	ISO 7150-2:1984(E)	Determination of Ammonium Part2: Automated spectrophotometric method
3	Chloride	ISO 9297:1989(E)	Determination of Chloride - silver nitrate titration with chromate indicator (Mohr's method)
4	Copper	ISO 8280:1986(E)	Flam Absorption Spectrophotometric method
5	Hardness	ISO 6059:1984	Determination of the sum of calcium and magnesium - EDTA titrimetric method
6	Hydrogen Sulfide	WHO, Vol-2, p243	Methylene blue colorimetric method
7	Iron	ISO 6332:1988(E)	Determination of Iron - Spectrometric Method using 1,10-phenanthroline
8	Manganese	ISO 6333:1986(E)	Determination of Manganese Formaldoxime spectrometric method
9	DO	WHO, Vol-2, p324	Electrochemical probe or dissolved oxygen meter
10	pH	ISO 10523:1990(E)	Determination of pH
11	Sodium	ISO 9964-3: 1993(E)	Determination of Sodium and potassium by flame emission spectrophotometry
12	Sulfate	ISO 9283:1990(E)	Gravimetric method
13	TDS	WHO, Vol-2, p367	Conductivity probe
14	Zinc	ISO 8283:1986(E)	Flam Absorption Spectrophotometric method
B	Disinfectant		
1	Chlorine	ISO 7393-2:1985(E)	Determination of free chlorine and total chlorine using N,N-diethyl-1, 4 phylenediamine, for routine control process

Table-11 Chemicals Of Health Significance

#	SUBSTANCE	REFERENCE	TEST METHOD
A	Inorganic Constituents		
1	Arsenic	ISO 6595:1982(E)	Determination of total Arsenic – silver diethyl dithiocarbonate spectrophotometric method
2	Barium	WHO, vol-2, p175	AAS, using either direct aspiration in to an air-acetylene flame or atomization in a furnace.
3	Boron	ISO 9590:1990(E)	Determination of Borate – spectrophotometric method using Azomethine-H
4	Cadmium	ISO 5961:1994(E) ISO 8288:1986(E)	Determination of cadmium – by AAS method Flam Absorption Spectrophotometric method
5	Chromium	ISO 11083:1994(E)	Determination of chromium (vi) – spectrometric method using 1,5-diphenylcarbazide
6	Copper	ISO 8288:1986(E)	Flam Absorption Spectrophotometric method
7	Cyanide	ISO 6703:1984(E)	Determination of cyanide- Part 1: Determination of total cyanide
8	Fluoride	ISO 10359-1:1992(E)	Electrochemical probe method - for potable and lightly polluted water
9	Lead	ISO 8288:1986(E)	Flam Absorption Spectrophotometric method
10	Manganese	ISO 6533:1986(E)	Determination of Manganese Formaldoxime spectrometric method
11	Mercury (total)	ISO 9965-3: 9984(E)	Determination of total mercury- by flameless AAS – method after digestion with bromine
12	Nitrate (as NO ₃ ⁻)	ISO 7890-3:1988(E)	Determination of nitrate- Part 3:spectrometric method using sulfosalicylic acid.
13	Nitrite (as NO ₂ ⁻)	ISO 6777:1984(E)	Determination of nitrite - Molecular Absorption spectrometric method
14	Selenium	ISO 9965:1993(E)	Determination of Selenium – AAS method (hydride technique)
B	Organic Constituents		
B1	Aromatic hydrocarbons		
1	Benzene	WHO, Vol-2, p462	A purge and trap gas chromatographic procedure with photoionization detection
2	Benzo[a]pyrene	WHO, Vol-2, p496	Gas chromatography in conjunction with mass spectrographic
B2	Chlorinated alkanes		
1	Carbon tetrachloride	WHO, Vol-2, p390	A purge and trap gas chromatography
2	1,2-dichloroethane	WHO, Vol-2, p411	A purge and trap gas chromatographic procedure
B3	Chlorinated ethenes		
1	1,1-Dichloroethene	WHO, Vol-2, p432	A purge and trap gas chromatographic procedure
2	Trichloromethene	WHO, Vol-2, p445	A purge and trap gas chromatographic procedure
3	Tetrachloroethene	WHO, Vol-2, p453	A purge and trap gas chromatographic procedure

Table-11 (Cont.)

C	Pesticides	Reference	Test Method
1	DDT	WHG, Vol-2, p639	Gas Chromatography with electron-capture detector.
2	Aldrine/Deldrine	WHG, Vol-2, p604	Extraction with pentane followed by Gas Chromatography with electron-capture detector
3	Chlordane	WHG, Vol-2, p628	Extraction with pentane followed by gas chromatography with electron capture detector
4	Pentachlorophenols	ISO 8165-1:1992(E)	Determination of selected monovalent phenols Part1: Gas-chromatographic method after enrichment by extraction
D	Disinfectant & disinfectant bi-product		
D1	Disinfectant		
1	Chlorine	ISO 7393-2:1985(E)	Determination of free chlorine and total chlorine using N,N-diethyl-1, 4 phylenediamine, for routine control process
D2	Disinfectant By-products		
D2.1	Chlorophenol		
1	2,4,6-Trichlorophenol	ISO 8165-1:1992(E)	Determination of selected monovalent phenols- Part 1: Gas chromatographic method after enrichment by extraction
D2.2	Trihalomethane		
1	Chloroform	WHG, Vol-2, p850	Gas chromatography- with detection by flame ionization, electron-capture, or mass spectroscopy

Table-12 Chemicals not of Health Significance at Concentration normally Found In Drinking Water

1	SUBSTANCE	REFERENCE	TEST METHOD
1	Asbestos	WHO, Vol-2, p168	Transmission electron microscopy (TEM) with identification by energy depressive X-ray analysis and selected-area electron diffraction (TEM/SAED)
2	Silver	WHO, vol-2, p339	Spectrographic and colorimetric method with diithi-zone
3	Tin	WHO, vol-2, p361	AAS either direct aspiration into a flame or furnace technique

Table-13 Radioactive Constituents of Drinking Water

S	SUBSTANCE	REFERENCE	TEST METHOD
1	Gross alpha activity	ISO 9696:1992	Measurement of Gross Alpha activity in non-saline water - thick source method
2	Gross beta activity	ISO 9697:1992	Measure of gross beta activity in non-saline water

6.0 SANITARY INSPECTION

Sanitary survey and WQ analysis are complementary activities that should be conducted by both the water supply agency as well as surveillance agency. The sanitary inspection forms, prepared in the form of checklist, are possible to determine an overall measure of the sanitary state of the supply.

6.1 Frequency of Sanitary Inspection

One of the most important surveys is that undertaken when new water sources are developed. When alternative water sources are under consideration, each should be surveyed. The guiding principle is that no new water supply should be approved without a sanitary inspection. Routine surveys of existing supplies should be undertaken periodically as stated in **Table-14** by the community, water supplier and surveillance agency.

Table-14 Minimum Annual Frequency of Sanitary Survey

S	Source & Mode of Supply	Community	Water-supply Agency	Surveillance Agency
1.0	On Spot supply			
1.1	Hand-dug well (Without windlass)	6	-	-
1.2	Hand-dug well (With windlass)	6	-	-
1.3	Dug well with hand-pump	4	-	0.5
1.4	Shallow & deep tube well with hand-pump	4	-	0.5
1.5	Gravity spring	4	-	0.5
2.0	Piped Supply			
2.1	Groundwater with & without chlorination	-	0.5	0.5
2.2	Treated surface water with chlorination; <5,000 Pop 5,000 to 20,000 Pop	-	0.5	0.5
		-	1	0.5
2.3	Distribution system of piped supply	-	6	0.5