

資 料

- 1 調査団員・氏名
- 2 調査行程
- 3 関係者（面会者）リスト
- 4 討議議事録（M/D）
- 5 参考資料
- 6 その他の資料・情報
 - 敷地測量図（現地再委託）
 - 地盤状況調査結果（現地再委託）
 - 地下水調査結果（現地再委託）

1. 調査団員・氏名

1-1 現地調査Ⅰ（2011年4月10日～5月13日）

総括	宮田 伸昭	JICA 国際協力専門員
計画管理（現地調査不参加）	甲田 小百合	JICA 人間開発部 基礎教育グループ 基礎教育第二課
調達監理計画	内田 修治	JICS 業務第一部施設第二課
業務主任/施設計画	大澤 智弘	株式会社マツダコンサルタンツ
建築設計 1/設備計画/給水施設	兵藤 要	株式会社マツダコンサルタンツ
建築設計 2	島田 光博	株式会社マツダコンサルタンツ
施工計画/積算 1	土屋 達嗣	株式会社マツダコンサルタンツ
施工計画/積算 2	徳永 俊一	株式会社マツダコンサルタンツ
機材計画	西矢 尚人	株式会社マツダコンサルタンツ
教育計画	八木 恵理子	株式会社マツダコンサルタンツ （合同会社適材適所）
通訳	田邊 早苗	株式会社マツダコンサルタンツ （翻訳センターパイオニア）

1-2 現地調査Ⅱ-1（2011年10月14日～10月28日）

業務主任/施設計画	大澤 智弘	株式会社マツダコンサルタンツ
建築設計 1/設備計画/給水施設	兵藤 要	株式会社マツダコンサルタンツ
建築設計 2	島田 光博	株式会社マツダコンサルタンツ
水理地質/試掘監理	佐野 正明	株式会社マツダコンサルタンツ （日本テクノ株式会社）
通訳	田邊 早苗	株式会社マツダコンサルタンツ （翻訳センターパイオニア）

1-3 現地調査Ⅱ-2（2011年12月14日～12月23日）

総括	宮田 伸昭	JICA 国際協力専門員
----	-------	--------------

計画管理	甲田 小百合	JICA 人間開発部 基礎教育グループ 基礎教育第二課
業務主任/施設計画	大澤 智弘	株式会社マツダコンサルタンツ
通訳	田邊 早苗	株式会社マツダコンサルタンツ (翻訳センターパイオニア)

1-3 現地調査 III (2012 年 2 月 22 日～3 月 2 日)

業務主任/施設計画	大澤 智弘	株式会社マツダコンサルタンツ
構造設計 1	井上 裕	株式会社マツダコンサルタンツ
通訳	田邊 早苗	株式会社マツダコンサルタンツ (翻訳センターパイオニア)

2. 調査行程

2-1 現地調査 I

	2011年		官団員		コンサルタント団員						
	月	日	団長	調達監理計画	業務主任/施設計画	建築設計2	施工計画/積算1	建築計画1/設備計画	教育計画	機材計画	施工計画/積算2
1	4月	10日	日	成田発→		成田発→	成田発→香港→				
2		11日	月	マプト着		マプト着	JNB→マプト着				
				JICA 表敬・打合せ MINED 次官表敬・協議			JICA 表敬・打合せ MINED 次官表敬・協議				
3		12日	火	DIPLAC 協議(インセプション説明) 在モザンビーク日本国大使館表敬 JICA 専門家ヒアリング(教員養成)			DIPLAC 協議(インセプション説明)				
4		13日	水	無償中学校建設現場視察(ガザ州) 団内会議			積算調査票 配布	CEE 入札 関連調査	統計資料 収集、他		
5		14日	木	マプト→ナンブラ移動 ナンブラ州教育局表敬・協議 既存 IFP 視察(Nampula・Marrere 校)			積算調査票 配布	マプト→ナンブラ移動 ナンブラ州教育局表敬・ 協議、既存 IFP 視察			
6		15日	金	IFP 要請サイト視察・協議(Moma)			積算調査	IFP 要請サイト視察・協議			
7		16日	土	中学校建設要請サイト視察 (Monapo, Nacala-a-Velha, Memba)			見積依頼	中学校建設要請サイト 視察			
8		17日	日	Monapo 郡長・教育事務所協議 郡教育長面談・ESG Monapo 視察 ナンブラ州教育局協議		成田発→	資料整理	Monapo 郡長・ 教育事務所協議他 ナンブラ州教育局協議		成田発→香港→	
9		18日	月	ナンブラ→マプト移動 団内会議		マプト→ ナンブラ移動		IFP Nampula 施設・教育 関連調査	マプト→ ナンブラ移動		
10		19日	火	DIPLAC 協議(M/D) 団内会議		IFP 要請サイト調査 (Monapo 郡)	IFP Marrere 施設・運営・機材調査			積算調査	
11		20日	水	文書作成	資料収集	中学校要請サイト調査 (Mossuril 郡)	IFP Nampula 運営・施設・機材調査			公共事業局	
12		21日	木	DIPLAC M/D 署名 文書作成		中学校要請サイト調査 (Memba 郡)	IFP 要請 サイト調査	州教育局 補足調査	調達事情	新 IFP 敷地	
13		22日	金	JICA 事務所・ 大使館報告	資料収集	中学校要請サイト調査 (Nakala-a-Velha, Monapo 郡)	IFPNampula DPEC 協議	州教育局 補足調査	CEE 機材 計画協議	JICS 協議 建設事情	
14		23日	土	マプト発→ JNB→	類似施設 調査	中学校要請サイト調査 資料整理・団内会議	IFPNampula 調査 (Nampula 郡)		マプト移動	無償中学校建設現場 (ガザ州)他視察	
15		24日	日	→香港 →成田着	無償中学校 現場視察	ナンブラ→モマ移動		資料整理	無償中学校建設現場 (マトラ州)他視察		
16		25日	月	免税関係 調査	機材・施設 計画協議	中学校要請サイト調査 (Moma 郡)	水質検査 掘削業者	CEE 機材・施設計画協議 DNFP 協議	JICS 協議 資料収集	免税関係	
17		26日	火	調達事情 調査	DNES 調査	中学校要請サイト調査 (Meconta 郡)	DPEC 協議 掘削業者	DNES 調査 FASE 調査	機材調達 事情調査	建設事情 公共事業省	
18		27日	水	入札関連 調査	マプト→ ナンブラ	中学校要請サイト調査 (Muecate 郡)	IFPNampula 調査	DRH 協議 教員調査	機材調達 事情調査	入札関連 調査	
19		28日	木	免税関係 調達事情	中学校要請サイト調査(Namapa 郡 教育事務所・サイト・既存中学校)	再委託見積 調査票作成	ドナー調査 資料収集	機材調達 事情調査	免税関係 調達事情		
20		29日	金		中学校要請サイト調査(Nampula 郡 教育事務所・サイト)→Malema 移動	再委託見積 調査票作成		マプト発→JNB→			
21		30日	土		中学校要請サイト調査(Malema 郡 教育事務所・サイト・既存中学校) IFP Alto Molocue 視察→ナンブラ移動	資料整理		→香港→成田着			
22	5月	1日	日	団内会議・資料整理							
23		2日	月	調査結果 解析・文書作成		ナンブラ→マプト移動 再委託見積調査票作成					
24		3日	火	ナンブラ州教育局協議 (サイト調査結果報告) ナンブラ→マプト移動		再委託見積依頼					

25	4日	水		CEE 施設計画協議	再委託関連 見積り回収	CEE 施設 計画協議	
26	5日	木		DNFP 施設 計画協議	電気公社、 水理局協議	見積り依頼 見積り回収	DNFP 施設 計画協議
27	6日	金		類似施設調査(マプト市) DIPLAC サイト調査結果 報告・協議	見積り依頼 見積り回収	同業務主任	
28	7日	土		文書作成	類似施設調査(ガザ州施 工中現場)	再委託見積 回収整理	
29	8日	日		団内会議・資料整理		マプト→ ナンブラ	
30	9日	月		DIPLAC 協議 補足調査	再委託関連 業務 積算調査 補足調査	再委託契約 類似施設 調査、他 →マプト	
31	10日	火		CEE 協議・ 補足調査 テクニカル ノート署名	再委託関連 業務 積算調査票 回収	CEE 協議・ 補足調査 再委託関連 業務	
32	11日	水		JICA・大使 館報告	再委託関連 業務 積算調査票 回収	JICA・大使 館報告	
33	12日	木		マプト発→JNB→			
34	13日	金		→香港→成田着			

略語
MINED : 教育省
DIPLAC : 協力計画局
CEE : 建設・教育機材部
DNES : 中等教育局
DNFP : 教員養成局
DR : 人的資源局
IFP : 初等教員養成校
ESG : 普通中学校
FASE : 教育セクター支援基金
JNB : ヨハネスバーグ
DPEC : 州教育文化局

2-2 現地調査 II

	2011年 月日	コンサルタント団員					
		業務主任/施設計画	建築設計 2	建築計画 1/設備計画	水理地質・試掘監理		
1	10月14日	金	成田発→香港→	(現地参团)	成田発→香港→		
2	15日	土	JNB→マプト着	再委託業務調整	JNB→マプト着		
			団内会議				
3	16日	日	マプト発→ナンブラ着				
4	17日	月	DPEC ナンブラ表敬・協議 IFP ナコロロサイト視察、DPEC ナンブラ表敬・協議		試掘業者調査・機材確認 作業資材調達		
5	18日	火	DPEC ナンブラ協議 ナンブラ発→マプト着	給水調査準備	IFP サイト調査 周辺小学校調査	試掘業者調査 IFP サイト調査	
6	19日	水	JICA 事務所表敬・打合 書類作成	ナンブラ→ナカラ移動 IFP サイト調査			
7	20日	木	DIPLAC 協議 同 CEE 資料収集	中学校サイト地域給水調査 (Memba/Nacala-a-Velha)			
8	21日	金	DIPLAC テクニカルノート署名、JICA 事務所 TV 会議 EOJ 表敬・報告	中学校サイト地域給水調査 (Mossuril)	Monapo 給水事情調査 Nacololo 給水事情調査	中学校サイト地域給水調査 (Mossuril)	
9	22日	土	2009 年度中学校建設 PJ 現 場視察	中学校サイト地域給水調査 (Namapa) ナカラ→ナンブラ移動			
10	23日	日	書類整理	中学校サイト地域給水調査 (Nampula City)		物理探査準備	
11	24日	月	CEE 資料収集 DNFP 調査 EDM 資料収集	中学校サイト地域給水調査 (Nampula City) 都市計画局協議	既存 IFP 補足調査 既存中学校補足調査	物理探査・データ解析 (水平探査)	
12	25日	火	書類作成、CEE 資料収集 MOPH 計画協力局調査	IFP サイト現地再委託説明 ナンブラ市都市計画局協議	既存 IFP 補足調査 ナンブラ発→マプト着	物理探査・データ解析 掘削機械検査	
13	26日	水	CEE 施設計画協議 JICA 事務所報告	DPEC ナンブラ報告・協議 FIPAG 協議 ナンブラ発→マプト着	CEE 施設計画協議 JICA 事務所報告	物理探査・データ解析 (垂直探査)	
14	27日	木	マプト発 → JNB →			物理探査・データ解析	
15	28日	金	→ 香港 → 羽田着			物理探査・データ解析	
							以降 12 月 24 日まで「ナンブ ラ初等教員養成計画」に係る 試掘監理を継続

2-3 現地調査 II-2 (ナンブラ州中学校改善計画概要説明)

	2011年 月日		官団員		コンサルタント団員	
			総括	計画管理	業務主任/施設計画	通訳
1	12月14日	水	羽田発→香港→		成田発→香港→	
2	15日	木	JNB→ナンブラ着		JNB→ナンブラ着	
			中学校サイト(Cidade de Nampula)視察			
3	16日	金	DPEC ナンブラ表敬、初等教員養成計画サイト(Nacololo)視察 DPEC ナンブラ協議(報告書案概要説明)			
4	17日	土	中学校サイト(Nacala-a-Velha、Membra-sede)視察			
5	18日	日	ナンブラ→マプト移動			
6	19日	月	JICA 事務所打合せ		同左、補足資料収集	
			教育省協議(DIPLAC):中学校改善計画ドラフト説明			
7	20日	火	「中学校建設計画」サイト視察(Kongolote、Ncobe) 団内打合せ		教育省 DIPLAC/CEE 協議、「中学校建設計画」サイト視察 (Kongolote)、 団内打合せ	
8	21日	水	ミニッツ署名(署名者:教育次官) 日本大使館報告			
9	22日	木	マプト発 →JNB →		マプト発 →JNB →	
10	23日	金	→ 香港 →羽田着		→ 香港 →羽田着	

略語

DIPLAC:協力計画局 CEE:協力計画局建設・教育機材部 JNB:ヨハネスバーグ DPEC:州教育文化局

2-4 現地調査 III (入札図書作成参考資料案説明)

	2012年 月日		コンサルタント団員		
			業務主任/施設計画	通訳	構造設計1(現地参团)
1	2月22日	水	成田発→香港→		
2	23日	木	JNB→マプト着、JICA 事務所表敬・打合せ 教育省 DIPLAC/CEE 表敬・協議		構造設計図準備
3	24日	金	「中学校建設計画」実施校(Chissano 中学校)視察		構造設計図準備
4	25日	土	団内打合せ・文書作成		
5	26日	日			
6	27日	月	教育省 DIPLAC/CEE 協議(入札図書作成参考資料案説明)		
7	28日	火	教育省 DIPLAC/CEE 協議(入札図書作成参考資料案協議)		設計変更対応案作成
8	29日	水	JICA 事務所/日本大使館報告 教育省 DIPLAC 報告 教育省 DIPLAC/CEE 資料回収		
9	3月1日	木	マプト発 →JNB →		
10	2日	金	→ 香港 →羽田着		

略語

DIPLAC:協力計画局 CEE:協力計画局建設・教育機材部 JNB:ヨハネスバーグ DPEC:州教育文化局

3. 関係者（面談者）リスト

モザンビーク国側関係機関

【Ministry of Education (MINED) 教育省】

Sra. Maria de Fátima Zacarias	Secretária Permanente	事務次官
DIPLAC : 計画協力局		
Sr.Manuel A.Magalhães Rego	Director, DIPLAC	計画協力局局长
Sra.Zaida Baule	Técnica	日本担当事務官
Sr.Constâncio Adelino	Técnico	統計部事務官
DIPLAC/CEE : 計画協力局建設・教育機材部		
Sr. Eugenio Maposse	Director	部長（現地調査 III）
Sr.Adolfo Baltazar Miti	Chefe do Departamento	技術課長
Sr.Felipe David Samuel	Arquitecto	技官
Sra.Niurka Contreras	Técnica	機材担当事務官
Sr.Pedro João Chale	Coordenador dos Projectos BID III e IV	電気技師（現地調査 II）
DINES: : 中等教育局		
Sr.Ivaldo Quicandite	Director	局長
Sr.Rogério Cossa	Chefe do Departamento	課長
DINFP : 教員養成局		
Sr.Joaquim Matavele	Director p/ Formação de Professores	局長（現地調査 I）
Sr. Feliciano Mahalambe	Director p/ Formação de Professores	局長（現地調査 II）
Sr.Raquel Raimundo	Chefe do Departamento	課長
Mr. Kenji Ohira	Advisor for Teacher Training Development	アドバイザー
DAF : 財務局		
Sr.Abílio Mabe	Chefe do Dep. de Gestão Financeiro	課長
Sr.José Tomo	Técnico	事務官
Sra.Ana Chiau	Técnica	事務官
Sr.Jhen Shah	Financial Coordinator	FASE 財務担当
INDE : 国立教育開発院		
Sr.Ismael Mêge	Professor/Director	所長

【MOPH 公共事業住宅省】

DNA : 水利局・農村給水担当

Sr.Eduardo Jossefa	Chefe da Secção de Planificação	計画課長
--------------------	---------------------------------	------

Sr.Renato Solomone	Secção de Comunicação • Capacitação	啓蒙・研修課技官
Sr.Francisco Naene	Técnico	データベース担当
Sr.Roberto Come	Técnico	農村給水技官
Sr.Alcino Nhacume	Técnico	農村給水技官

DNE : 建設局

Sr.Ângelo Augusto M.Benesse	Director Nacional de Edificações	局長
Sr.Marcelino Jacob J.Salimo	Técnico, Repartição de Conservação	建設保存技官

DPC : 計画協力局

Sr.Humberto Gueze	Director	局長 (現地調査 II)
Sr.Joel Mondlane	Técnico	技官 (現地調査 II)

【Nampula ナンプラ州】

DPEC : 州教育文化局

Sra.Páscoa Azevedo	Directora	局長
Sr.José Óscar B.Chichava	Director Adjunto	副局長
Sr.Aderito Gabriel	Chefe da Secretaria	局長室長
Sr.Anselmo Castro	Chefe do Depart. de Planificação	計画部長
Sr.Fernando R.Paulo	Técnico de Planificação	計画事務官
Sr.Pedro Mequene	Técnico de Planificação	計画事務官 (現地調査 I)
	Chefe da Repartição de Planificação	計画課長 (現地調査 II)
Sr.Abdul C.Samuel	Técnico de Construções	建設担当事務官
Sr.Naércio Williams	Técnico de Construções	建設担当事務官
Sr.Manuel Aissa	Técnico de Finanças	建設担当事務官
Sra.Rosalina Artur	Repartição do Ensino Básico	基礎教育担当
Sr.Caetano Cunhete	Repartição do Ensino Secundário	中等教育担当
Sr.José Adolfo	Chefe do Dep. de Recursos Humanos	人材部長
Sr.Armatrico Simpengua	Chefe do Dep. de Património	資産管理部長
Sr.Artur Cumbane	Técnico de Património	資産管理 (現地調査 I)
	Chefe do Depart. de Construção	建設部長 (現地調査 II)

Institute of Language, Nampula : ナンプラ語学専門学校

Sr.Joao Sales	Director	校長
---------------	----------	----

EDM : モザンビーク電力公社

Sr.Carlos Rafael Jossai	Director EDM Nacala	EDM Nacala 局長
-------------------------	---------------------	---------------

Cidade de Nampula : ナンプラ市

Sr.Alexandrino Momade	Técnico de Planificação	教育部計画技官
-----------------------	-------------------------	---------

Sr.Muiambo	Director Urbanização	都市計画部長
Sra.Hortencia A. Mumbale	Chefe do PA Urbani de Natikiri	ナティキリ区区長

Distorito de Moma : Moma 郡

Sr. Antonio Juliao	Director de Educação-SDEJT	教育部長
Sr.Francisco A.Alage	Director do DPI	インフラ部長
Sra.Elizabeth Fageeira	Chefe da Repart. Rec. Humanos-SDEJT	教育部人材課長
Sr.Sekou G.Cisse	Técnico de Planificação	計画部技官
Sr.Augusto Lucia de Aiúba	Director, EPC Micane(Moma)	EPC Micane 校長

Distorito de Monapo : Monapo 郡

Sr.Salvador Talapa	Administrador	郡長
Sr.Marto Ramadani	Vereador de Educação e Cultura	教育文化担当議員
Sra.Jacinta Faria Macário	Directora da SDEJT	教育青年技術部長
Sr.Felizardo Chanfar	Chefe Repartição de Educ. Geral-SDEJT	教育課長
Sr.Augusto Gelo	Chefe da Repart. Rec. Humanos-SDEJT	教育部人材課長
Sr.Justino Jaime	Técnicido de Planificação-SDEJT	教育部計画担当技官
Sr.Paulino Muligeque	Repartição de Educação-SDEJT	教育課員
Sr.Lourenço Xavier	Técnico Planificaador físico-SDPI	建設部計画技官

Localidade de Nacololo: Nacololo 村

Sr.Amisse Martinho	Chefe da Localidade de Nacololo	ナコロロ村長
Sr.Orlando Muziva	Régulo	伝統的首長
Sr. Jorge Mutinia	Director de EP Narere	ナレレ小学校長
Sr. Natalio Assane	Secretary of Narere Neighbourhood	ナレレ地区長

Distorito de Nacala-a-Velha : Nacala-a-Velha 郡

Sr.Janiel Chapo	Administrador	郡長
Sra.Julieta Mário Antonio	Directora de Educação-SDEJT	教育部長 (現地調査 I)
Sr.Hermino Baltazar	Director de Educação-SDEJT	教育部長 (現地調査 II-2)
Sr. Basilio Pedro Hamela	Deputy Director of SDEJT	教育部副部長
Sra.Luisa Beatriz Aurélio	Directora de Activ. Economicas	経済活動部長
Sra.Gilda Daude Guambe	Planning Technician of SDEJT	教育部計画技官
Sr.Paulo Cebo	Planning Technician of SDEJT	教育部計画技官
Sr. Felismino Jamal	District Infrastructural Technician	インフラ担当技官

Distorito de Memba : Memba 郡

Sra.Maria Felisbela C.Lázaro	Administradora	郡長
Sr.Rodrigues Celestino	Chefe Repartição de Educ. Geral-SDEJT	普通教育課長
Sr.Felix Miriasse Nacamo	Director de Infraestrutura	インフラ部長

Sr. Jacinto Inacio Assane	Agricultural Tecnician PA de Momba-sede	Momba-sede 地区農業技官
Sr. Dinho Momade	District Secretary of National Teachers Organization	教員組合 Momba 郡事務官
Sr. Napueo	Régulo, 1st Grade Community Leader	伝統的首長

Distorito de Mossuril : Mossuril 郡

Sr.Mario Paciano	Director de Educação-SDEJT	教育部長
Sr.Eusebio Coholia	Chefe Repartição de Educ. Geral-SDEJT	教育課長
Sr.Rafael Mucuchiua	Técnica de Planeamento	計画部技官

Distorito de Muecate : Muecate 郡

Sr.Constantino Pirai	Director de Educação-SDEJT	教育部長
----------------------	----------------------------	------

Distorito de Meconta : Meconta 郡

Sr.Agostinho Uanieque	Director de Educação-SDEJT	教育部長
-----------------------	----------------------------	------

Distorito de Nampula : Nampula 郡

Sra.Maria Pascoela C. M. N. Talaquichande	Directora de Educação-SDEJT	教育部長
---	-----------------------------	------

Distorito de Malema : Malema 郡

Sr.Agostinho Luis	Directora de Educação-SDEJT	教育部長
-------------------	-----------------------------	------

Distorito de Namapa-Eráti : Namapa-Eráti 郡

Sr.Andre Neto De Adelino Atonso	Director de Educação-SDEJT	教育部長
Sr.Gustavo Castelo	Técnica de Planeamento	計画部技官
Sr. Amilcar João	Secretary of Acucha Neighborhood	Acucha 地区長

IFP Nampula

Sr.Ussene Amade	Director	校長
Sr.Carlos Marcelino	Director Adjunto p/Internato	寮長
Sr.Herculano Micorosse	Director Adjunto p/Ensino Pedag.	教務課長

IFP Marrele

Sr.Belmiro Nhamposse	Director	校長
----------------------	----------	----

Escolas Secundárias : 中学校

Sr.Abel Nacua Gabriel Camaino	Director / ESG Mossuril	ESG Mossuril 校長
Sr.Cecilia Alama Xavier	Director / ESG Momba	ESG Momba 校長
Sr.Monig Jaquissone	Director / ESG Nacala-a-Velha	ESG Nacala-a-Velha 校長
Sr.Cassimo Natunga	Director / ESG Moma	ESG Moma 校長

Sr.Remigio Jonas	Director / ESG Meconta	ESG Meconta 校長
Sr.Constantino Cipriano	Director / ESG Corrane	ESG Corrane 校長
Sr.Armino Novais	Director / ESG Muecate	ESG Muecate 校長
Sr.Valdemiro David Abacar	Director / ESG Namapa	ESG Namapa 校長
Sr.Moinfe César	Director / ESG Muatala	ESG Muatala 校長

DPOPH DAS : 公共事業住宅局上下水道課

Sr. Agosto Fernando	Técnico de Hidráulico	給水設備技師
---------------------	-----------------------	--------

Hospital Cetral de Nampula Laboratorio de Higiene de Água e Alimentos : ナンプラ中央病院食糧・水衛生研究所

Dr. Estevão Mirione	Chief of Laboratory	検査所長
---------------------	---------------------	------

【Maputo マプト市】

ESG Quisse Mavota

Sr.Artur Armando Dombo	Director	校長
Sr.Felipe Alfiado	Director Adj. Pedagógico	教務担当副校長

EDM

Sr.António Chavo	Chefe, Depart. de Distribuição	配電担当課長
------------------	--------------------------------	--------

Laboratorio de Engenharia de Moçambique (LEM) : モザンビーク工学研究所

Sr.Manuel Arouca	Engenheiro Técnico	技術者
------------------	--------------------	-----

日本国側関係機関

【在モザンビーク日本国大使館】

橋本 栄治	Ambassador	特命全権大使
浜田 圭司	Conselheiro	参事官
遠藤 亜希	Assessor	館員

【JICA モザンビーク事務所】

宿野部 雅美	Chefe de Representante	所長 (現地調査 I, II)
那須 隆一	Chefe de Representante	所長 (現地調査 II-2)
大江 佐知子	Assistente do Representante Residente	所員
長谷川 博之	Assessor	企画調査員
Sr.Simões Victorina	Consultant	現地所員

4. 討議議事録 (M/D)

4-1 現地調査 I

MINUTES OF DISCUSSIONS
ON
PREPARATORY SURVEY
ON
THE PROJECT FOR CONSTRUCTION OF 20 SECONDARY SCHOOLS
IN THE NORTHERN REGION
IN
THE REPUBLIC OF MOZAMBIQUE

In response to the request from the Government of the Republic of Mozambique (hereinafter referred to as "Mozambique"), the Government of Japan decided to conduct a Preparatory Survey on the Project for Construction of 20 Secondary Schools in the Northern Region (hereinafter referred to as "the Project") and entrusted the survey to Japan International Cooperation Agency (hereinafter referred to as "JICA").

JICA sent Mozambique the Preparatory Survey Team (hereinafter referred to as "the Team"), which is headed by Mr. Nobuaki MIYATA, Visiting Senior Advisor, JICA and is scheduled to stay in the country from April 11th, 2011 to May 11th, 2011.

The Team had a series of discussions with the Mozambican officials concerned and conducted field surveys.

In the course of discussions and field survey, both parties confirmed the main items described on the attached sheets.

Maputo, Mozambique
April 21st, 2011

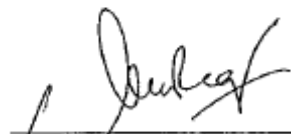

Ms. Maria de Fatima Zacarias
Permanent Secretary
Ministry of Education,
The Republic of Mozambique



Mr. Nobuaki MIYATA
Leader
Preparatory Survey Team
Japan International Cooperation Agency

ATTACHMENT

1. Objective of the Project

Objective of the Project is to improve the access and the learning environment of the secondary education by constructing new secondary schools in Nampula province in Mozambique, which leads to the improvement of the quality of secondary education.

2. Responsible and Implementing Organization

Responsible and implementing organization of the Project is the Ministry of Education, (hereinafter referred to as "MOE"), of which Organizational Chart is shown in ANNEX 1.

3. Project Sites

MOE requested to add a candidate site in Nampula city in addition to the original 10 sites and JICA agreed. The selection of the construction sites will be made based on the criteria shown in ANNEX 2, in consideration of the budget limitation of the Government of Japan. The order of priority made by the Mozambican side shown in ANNEX 3 will be taken into consideration when selecting the construction sites.

4. Project Components

Both sides agreed that the standard components of the Project would include following items:

Facilities:

1st priority items

- Administration Block
- Classrooms
- Science Laboratory
- Computer Room
- Library
- Toilet Block
- Guard House

2nd priority items

- Covered Sports Field
- Changing Room
- Teachers Houses

Equipments:

- Furniture for Administrative Block, Classrooms, Science Laboratory and Library

If there are some existing facilities on candidate sites, which are in good condition and can be utilized, those facilities will be excluded from the Project components. Such details will be examined by the Team during the field survey, which will end on 11th of May.



5. Japan's Grant Aid Scheme

5-1. The Mozambique side understands the Japan's Grant Aid for Community Empowerment described in ANNEX 5, ANNEX 6, ANNEX 7, and ANNEX 8, which were explained by the Team.

5-2. The Mozambique side assured to take the necessary measures, as described in ANNEX 9, for the smooth implementation of the Project.

6. Framework of Project Implementation and Scope of Works

The Team explained the following framework of implementation.

6-1. Japan's Grant Aid is extended in accordance with the "Exchange Notes" by the two governments concerned and with the "Grant Agreement" between JICA and the Government of Mozambique, in which the objectives of the Project, period of execution, conditions and amount of Grant Aid, etc., are confirmed.

6-2. After concluding the Exchange Notes and Grant Agreement, the Mozambique side shall make the Agent Agreement with Japan International Cooperation System (hereinafter referred to as "JICS"). In accordance with "Procurements Guideline for Grand Aid for Community Empowerment (Type I -C)" of JICA, JICS shall conduct the following works on behalf of the Government of Mozambique:

- (1) Administration of the Grant;
- (2) Preparation for and evaluation of tender;
- (3) Signing contracts with suppliers and service providers;
- (4) Procurement of necessary goods;
- (5) Payment to suppliers and service providers;
- (6) Assisting to organize committee meetings; and
- (7) Management of the progress of the project.

6-3. To implement the project smoothly, both sides confirmed to facilitate a committee composed of the Government of Mozambique, the Government of Japan and JICA. The members of the committee shall be as follows:

- (1) Representative(s) of MOE;
- (2) Representative(s) of JICA Mozambique Office;
- (3) Representative of Embassy of Japan in Mozambique may also attend as an observer;

Major functions of the committee are examining major changes of the Project, receiving the report of the progress, and examining the utilization plan of additional procurement (if any), etc.



7. Tentative Schedule of the Survey

7-1. The Team will proceed to further studies in Mozambique until May 11th, 2011.

7-2. If the result of the field survey discovers no administrative and technical difficulties in implementing the Project by adopting the Japan's Grant Aid for Community Empowerment, JICA will send another preparatory survey team in October.

7-3. After the contents of the report are accepted in principle by the Government of Mozambique, JICA will recommend to the Government of Japan for the final approval of the Project. Simultaneously, the Team will proceed to prepare the draft tender documents for the Project.

8. Other Relevant Issues

Government of Mozambique and JICA agreed the possibility to change the Project title from "The Project for Construction of 20 Secondary Schools in the Northern Region" to "The Project for the Construction of Secondary Schools in Nampula Province".

END

- ANNEX 1: Organizational Chart of MOE
- ANNEX 2: Criteria of Selecting Project Sites
- ANNEX 3: List of the Candidate Sites with priority order made by Mozambique
- ANNEX 4: Site Location Map of the Candidate Sites for the Project
- ANNEX 5: Grant Aid for Community Empowerment of the Government of Japan
- ANNEX 6: Implementation Flow of Japan's Grant Aid for Community Empowerment after E/N and G/A
- ANNEX 7: Flow Chart of Japan's Grant Aid Procedures for Community Empowerment
- ANNEX 8: Flow of Funds for implementation under the Japan's Grant Aid for Community Empowerment
- ANNEX 9: Major Undertakings to be Taken by Each Government

Handwritten signature and initials in the bottom right corner of the page.

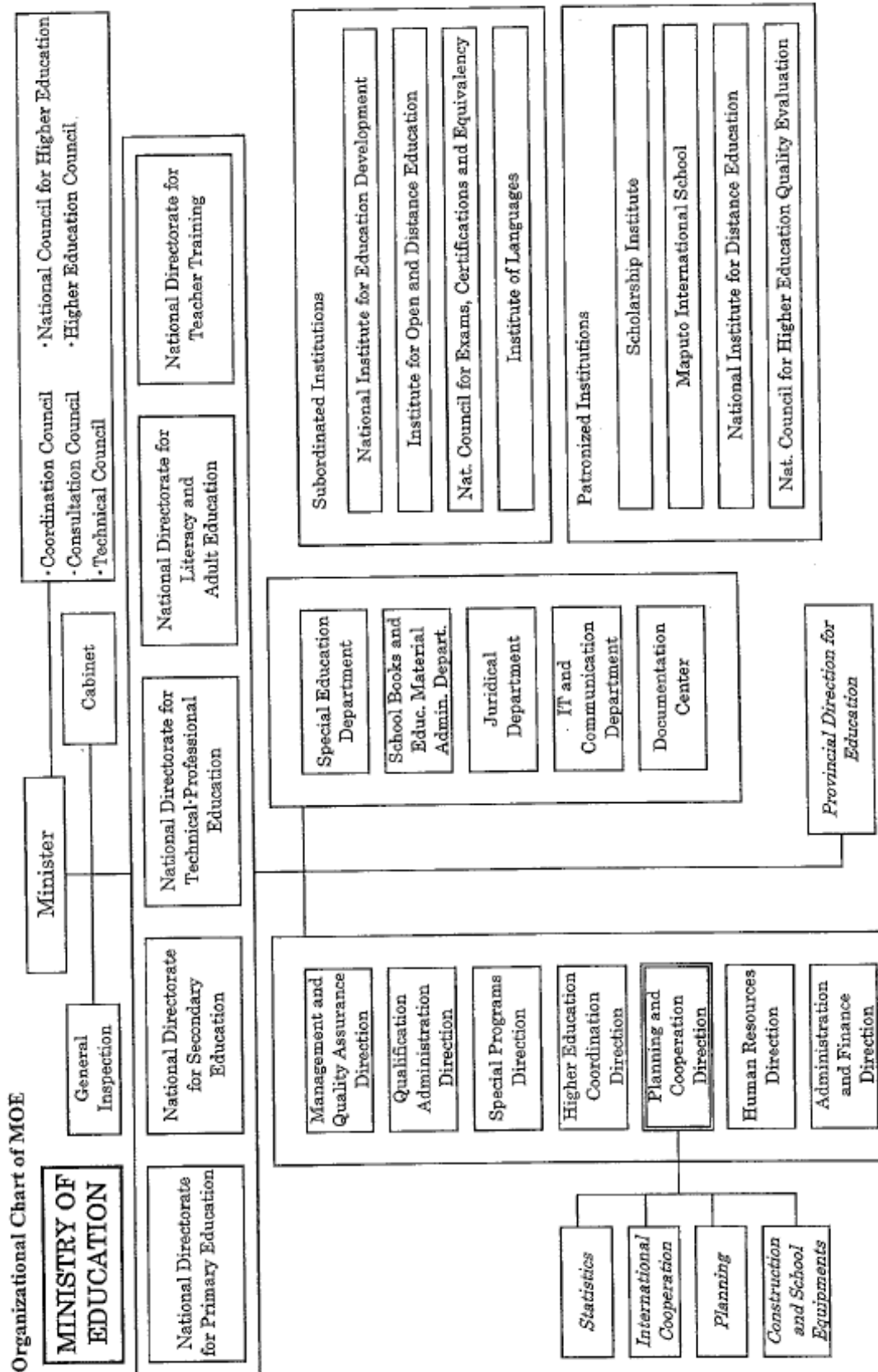

Sub
N.M.

Criteria of Selecting Project Sites

【Minimum Requirements】

1. MOE can present (an) official document(s) that verify its ownership or land-use right over the site.
2. The extent of the site is sufficient to construct the proposed facilities including future expansion.
3. There is no serious risk of being damaged by natural disasters (or no record of such damages).
4. There is no security concern around the site.
5. There is no hindrance for construction and supervision in terms of physical access to the site, working space, geographical conditions, etc.
6. There is no requirement of resident moving, or MOE and limited residents in the site reach the agreement on the moving. There is no negative impact on surrounded area.
7. There are water and electricity supply;
7-1 Water supply; There is existing city water supply, or a high prospect of sufficient ground/underground water supply.
7-2 Electricity supply; There is sufficient electric power supply.
8. There is no duplicated plan of construction by other donors and/or NGOs.
9. MOE can present a certificate or (an) official document(s) that verify the completion of the land mine removal.

【Criteria of Prioritizing Candidate Sites】

The candidate site should be prioritized if;

1. no secondary school has been constructed in the catchment area of the candidate site(hereinafter referred to as "the catchment area") since 1975
2. primary school facilities are utilized for secondary school education since there are no secondary schools in the catchment area,
3. the catchment area is remarkable in sharp population increase and doesn't have any secondary school
4. the catchment area is remarkable in sharp population increase and facing a serious overcrowded situation due to the shortage of classrooms



List of the Candidate Sites with Priority Order Made by Mozambique Side

Priority by the Mozambique side	District	Location
1	Moma	Moma-sede
2	Cidade de Nampula	Cidade de Nampula
3	Memba	Memba-sede
4	Monapo	Monapo-sede
5	Namapa-Erati	Namapa-sede
6	Nacala-Velha	Nacala-A-Velha
7	Muecate	Muecate-sede
8	Nampula-District	Rapale
9	Mossuril	Mossuril
10	Malema	Malema-sede
11	Meconta	Meconta-sede



Site Location Map of the Candidate Site for the Project



Handwritten signature

Grant Aid for Community Empowerment
of the Government of Japan
(Provisional)

The Government of Japan (hereinafter referred to as "the GOJ") is implementing the organizational reforms to improve the quality of ODA operations, and as a part of this realignment, the new JICA law was entered into effect on October 1, 2008. Based on the law and the decision of the Government of Japan (hereinafter referred to as "the GOJ"), JICA has become the executing agency of Grant Aid for Community Empowerment (hereinafter referred to as "GACE").

The Grant Aid provides the government of a recipient country (hereinafter referred to as "the Recipient") with non-reimbursable funds to procure the facilities, equipment and services (engineering services and transportation of the products, etc.) for economic and social development of the country under principles in accordance with the relevant laws and regulations of Japan. The Grant Aid is not supplied through the donation of materials as such.

1. Procedures for GACE

GACE is executed through the following procedures.

Application	Request made by a recipient country
Survey	Preparatory Survey conducted by JICA
Appraisal & Approval	Appraisal by the Government of Japan and JICA, and Approval by the Japanese Cabinet
Determination of Implementation	The Notes (hereinafter referred to as "E/N") exchanged between the Governments of Japan and the recipient country
Grant Agreement (hereinafter referred to as "the G/A")	Agreement concluded between JICA and a recipient country
Implementation	Implementation of the Project on the basis of the G/A

Firstly, the application or request for a GACE Project submitted by the Recipient is examined by the Government of Japan (the Ministry of Foreign Affairs) to determine whether or not it is eligible for GACE.

Secondly, if the request is deemed appropriate, the Government of Japan entrusts JICA (Japan International Cooperation Agency) to conduct the Preparatory Survey, using a Japanese consulting firm.

Jeck
N. M.

Thirdly, the Government of Japan and JICA appraise the Project to see whether or not it is suitable for Japan's GACE, based on the Preparatory Survey report prepared by JICA, and the results are then submitted to the Japanese Cabinet for approval.

Fourthly, the Project, once approved by the Cabinet, becomes official with the Exchange of Notes (E/N) signed by the Governments of Japan and the Recipient.

Simultaneously, the Grant will be made available by concluding a Grant Agreement (hereinafter referred to as "G/A") between the Government of the Recipient Country or its designated authority and the Japan International Cooperation Agency (JICA). JICA is designated by the Government of Japan as an organization responsible for the proper execution of the Grant.

Procurement Agent ("the Agent") is designated to conduct the procurement services of products and services (including fund management, preparing tenders, contracts and so on) for GACE on behalf of the Recipient. The Agent is an impartial and specialized organization and shall render services according to the Agent Agreement with the Recipient. The Agent is recommended to the Recipient by the Government of Japan and agreed between the two Governments in the Agreed Minutes ("A/M").

2. Preparatory Survey

1) Contents of the Survey

The aim of the Preparatory Survey ("the Survey"), conducted by JICA on a requested Project ("the Project"), is to provide a basic document necessary for the appraisal of the Project by the Government of Japan and JICA. The contents of the Survey are as follows:

- (1) Confirmation of the background, objectives, and benefits of the Project and also institutional capacity of agencies and communities concerned of the recipient country necessary for the Project's implementation;
- (2) Evaluation of the appropriateness of the Project to be implemented under the Grant Aid Scheme for Community Empowerment from a technical, social and economic point of view;
- (3) Confirmation of items agreed upon by both parties concerning the basic concept of the Project;
- (4) Preparation of an outline design of the Project ;
- (5) Estimation of cost for the Project ; and
- (6) Preparation of reference documents for tender.

The contents of the original request by the Government of the recipient country are not necessarily approved in their initial form as the contents of the Grant Aid project.

Jed
V. M

The Outline Design of the Project is confirmed considering the guidelines of Japan's Grant Aid scheme.

JICA requests the Government of the recipient country to take whatever measures are necessary to ensure its self-reliance in the implementation of the Project. Such measures must be guaranteed even though they may fall outside of the jurisdiction of the organization in the recipient country actually implementing the Project. Therefore, the implementation of the Project is confirmed by all relevant organizations of the recipient country through the Minutes of Discussions.

2) Selection of Consultants

For smooth implementation of the Survey, JICA uses registered consulting firms. JICA selects firms based on the proposals submitted by interested firms. The firms selected carry out a Preparatory Survey and write a report, based upon terms of reference set by JICA. The consulting firms used for the Survey shall be nominated as a responsible Japanese consultant (hereinafter referred to as "the Japanese Consultant") for proceeding construction supervision for the Project under the Agent in order to maintain technical consistency. The Japanese Consultant shall organize an appropriate construction supervision team utilizing local consultants.

3) Result of the Survey

The Report on the Survey is reviewed by JICA. The appropriateness and feasibility of the Project is confirmed, JICA recommends the GOJ to appraise the implementation of the Project.

3. Implementation of GACE after the E/N and G/A

1) Exchange of Notes (E/N) and Grant Agreement (G/A)

After the project approved by the Cabinet of Japan, the E/N will be signed between the GOJ and the Government of the recipient country to make a pledge for assistance, which is followed by the conclusion of the G/A between JICA and the Government of the recipient country to define the necessary articles to implement the Project, such as payment conditions, responsibilities of the Government of the recipient country, and procurement conditions.

2) Procedural details

Procedural details on the procurement of products and services under GACE will be agreed upon between the Recipient and JICA at the time of the signing of the G/A. Essential points to be agreed upon are outlined as follows:

Jack
N/m

- a) JICA executes the Grant by making payments of the amount agreed upon in the E/N and pays serious attention to ensure the accountability on proper and effective use of the Grant for the Project.
- b) The products and services shall be procured and provided in accordance with "Procurement Guidelines of Japan's Grant Aid (Type I - C)".
- c) The Government of the recipient country shall conclude an employment contract with the Agent.
- d) The Government of the recipient country shall designate the Agent as the representative acting in the name of the Government of the recipient country concerning all transfers of funds to the Agent.

3) Focal Points of JICA's "Procurement Guidelines of Japan's Grant Aid (Type I - C)"

a) The Agent

The Agent is the organization which provides procurement services of products and services on behalf of the Recipient according to the Agent Agreement with the Recipient. The Agent is recommended to the Recipient by the Government of Japan and agreed between the two Governments in the A/M.

b) Agent Agreement

The Recipient shall conclude an Agent Agreement, within two (2) months after the date of entry into force of the G/A, in accordance with the A/M. The scope of the Agent's services shall be clearly specified in the Agent Agreement.

c) Approval of the Agent Agreement

The Agent Agreement, which is prepared as two identical documents, shall be submitted to JICA by the Recipient through the Agent. JICA confirms whether or not the Agent Agreement is concluded in conformity with the E/N, the G/A, and the JICA's Procurement Guidelines of Japan's Grant Aid for Community Empowerment, and approves the Agreement. The Agent Agreement concluded between the Recipient and the Agent shall become effective after the approval by JICA in a written form.

d) Payment Methods

The Agent Agreement shall stipulate that "regarding all transfers of the fund to the Agent, the Recipient shall designate the Agent to act on behalf of the Recipient and issue a Blanket Disbursement Authorization ("the BDA") to conduct the transfer of the fund (Advances) to the Procurement Account from the Recipient Account."



The Agent Agreement shall clearly state that the payment to the Agent shall be made in Japanese yen from the Advances and that the final payment to the Agent shall be made when the total Remaining Amount becomes less than 3 % of the Grant and its accrued interest excluding the Agent's fees.

e) Products and Services Eligible for Procurement

Products and services to be procured shall be selected from those defined in the G/A.

f) Consultant Firms

In principle, the consultants (physical persons or juridical persons including universities, NGOs, and others with expertise and experience) that will be employed to do detail design and supervise the work for the Project / the Programme may be Japanese nationals recommended by JICA, for the purpose of maintaining technical consistency with the preliminary examination and other related studies, conducted prior to the signing of the G/A.

g) Contractor & Supplier Firms

In principle, Firms for construction works of only the recipient country's nationality could be contracted as construction contractors as long as the firm satisfies the conditions specified in the tender documents. Besides, Firms of any nationality could be contracted as suppliers as long as the firm satisfies the conditions specified in the tender documents.

h) Method of Procurement

In implementing procurement, sufficient attention shall be paid so that there is no unfairness among tenderers who are eligible for the procurement of products and services. For this purpose, competitive tendering shall be employed in principle.

i) Tender Documents

The tender documents should contain all information necessary to enable tenderers to prepare valid offers for the products and services to be procured by GACE. The rights and obligations of the Recipient, the Agent and the Suppliers of the products and services should be stipulated in the tender documents to be prepared by the Agent. Besides this, the tender documents shall be prepared in consultation with the Recipient.

Handwritten signature and initials in the bottom right corner of the page.

j) Pre-qualification Examination of Tenderers

The Agent may conduct a pre-qualification examination of tenderers in advance of the tender so that the invitation to the tender can be extended only to eligible firms. The pre-qualification examination should be performed only with respect to whether or not the prospective tenderers have the capability of accomplishing the contracts concerned without fail. In this case, the following points should be taken into consideration:

- (1) Experience and past performance in contracts of a similar kind;
- (2) Property foundation or financial credibility; and
- (3) Existence of offices, etc. to be specified in the tender documents.

k) Tender Evaluation

The tender evaluation should be implemented on the basis of the conditions specified in the tender documents. Those tenders, which substantially conform to the technical specifications, and are responsive to other stipulations of the tender documents, shall be judged in principle on the basis of the submitted price, and the tenderer who offers the lowest price shall be designated as the successful tenderer.

The Agent shall prepare a detailed tender evaluation report clarifying the reasons for the successful tender and the disqualification and submit it to the Recipient to obtain confirmation before concluding the contract with the successful tenderer. The Agent shall, before a final decision on the awards is made, furnish JICA with a detailed evaluation report of tenders, giving the reasons for the acceptance or rejection of tenders.

l) Additional Procurement

If there is an additional procurement fund after competitive and / or selective tendering and / or direct negotiation for a contract, and the Recipient would like an additional procurement, the Agent is allowed to conduct an additional procurement, following the points mentioned below:

(1) Procurement of the same products and services

When the products and services to be additionally procured are identical with the initial tender and a competitive tendering is judged to be disadvantageous, the additional procurement can be implemented by a direct contract with the successful tenderer of the initial tender.

(2) Other procurements

John
N. H.

When products and services other than those mentioned above in (1) are to be procured, the procurement should be implemented through a competitive tendering. In this case, the products and services for additional procurement shall be selected from among those in accordance with the E/N and the G/A.

m) Conclusion of the Contracts

In order to procure products and services in accordance with the G/A, the Agent shall conclude contracts with firms selected by tendering or other methods.

n) Terms of Payment

The contract shall clearly state the terms of payment. The Agent shall make payment from the "Advances", against the submission of the necessary documents from the Firm on the basis of the conditions specified in the contract, after the obligations of the Firm have been fulfilled. When the services are the object of procurement, the Agent may pay certain portion of the contract amount in advance to the firms on the conditions that such firms submit the advance payment guarantee worth the amount of the advance payment to the Agent.

4) Major Undertakings to be taken by the Government of the recipient country

(a) In the implementation of the Grant Aid Project, the recipient country is required to undertake such necessary measures as the following:

- (1) to secure lots of land necessary for the implementation of the Project and to clear the sites;
- (2) to provide facilities for distribution of electricity, water supply and drainage and other incidental facilities necessary for the implementation of the Project outside the sites referred to in (a) above;
- (3) to ensure prompt customs clearance and to assist internal transportation in the recipient country and to assist internal transportation therein of the products;
- (4) to ensure that customs duties, internal taxes and other fiscal levies which may be imposed in the recipient country with respect to the purchase of the Components as well as the employment of the Agent be exempted/be borne by its designated authority without using the Grant and its accrued interest;
- (5) to accord Japanese nationals and / or nationals of third countries, including



such nationals employed by the Agent, whose services may be required in connection with the supply of the Components such facilities as may be necessary for their entry into the recipient country and stay therein for the performance of their work (The term "nationals" whenever used in the G/A means Japanese physical persons or Japanese juridical persons controlled by Japanese physical persons in the case of Japanese nationals, and physical or juridical persons of third countries in the case of nationals of third countries.);

(6) to ensure that the Facilities and the Components be maintained and used properly and effectively for the implementation of the Project;

(7) to bear all the expenses, other than those covered by the Grant and its accrued interest, necessary for the implementation of the Project; and

(8) to give due environmental and social consideration in the implementation of the Project.

(b) Upon the request of JICA, the Recipient shall provide JICA with necessary information on the Project.

(c) With regard to the shipping and marine insurance of the products procured by the Project, the Recipient shall refrain from imposing any restrictions that may hinder fair and free competition among the shipping and marine insurance companies.

(d) The products procured by the Project shall not be exported or re-exported from the recipient country.

(e) The Recipient shall ensure that any official of its government does not undertake any part of the Japanese nationals' work and / or the work of nationals of third countries on purchase of the Components.

Handwritten signature and initials in the bottom right corner of the page.

Implementation Flow of Japan's Grant Aid for Community Empowerment after E/N and G/A

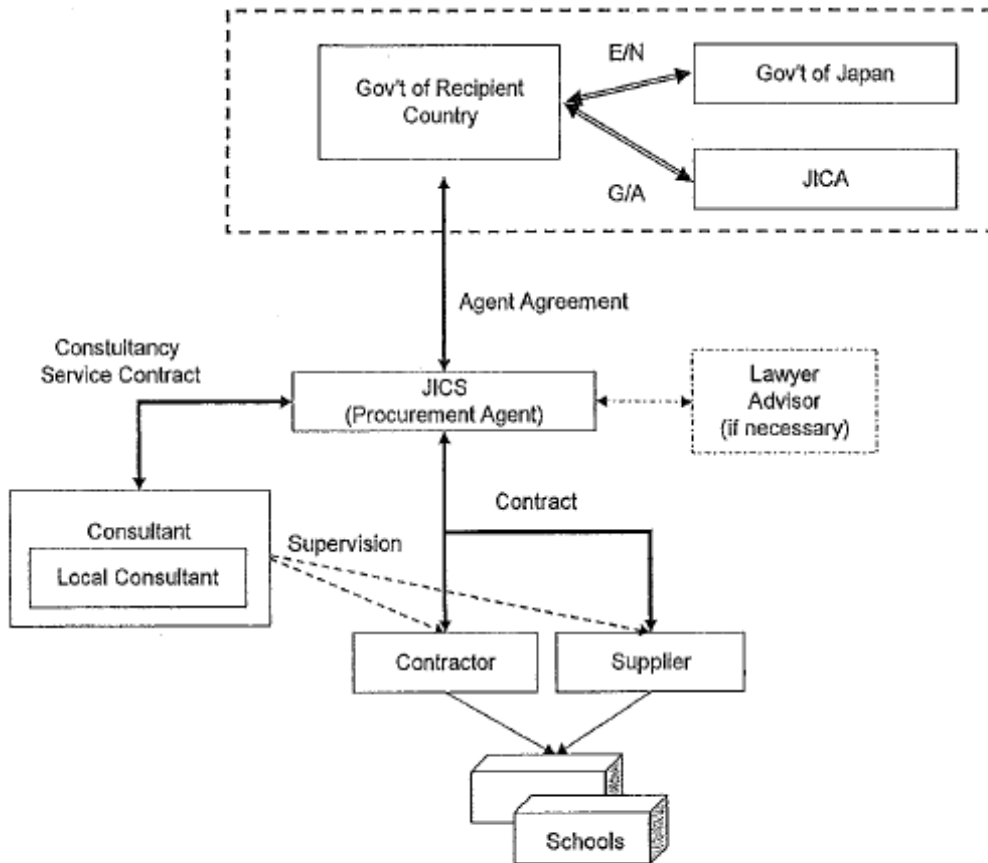

Jeal

Flow Chart of Japan's Grant Aid Procedures for Community Empowerment

Stage	Flow & Works	Recipient Government	Japanese Government	JICA	JICS(Agent)	Consultant	Contractor	Others
Application	Request ↓ Screening of Project ↓ Evaluation of TOR ↓ Project Identification Survey (TOR: Terms of Reference)	○						
Project Formulation & Preparation	Field Survey 1 Set the Scope of the Project ↓ Field Survey Interview Home Office Project Cost Estimation ↓ Decision for further steps for implementation	○	○	○		○		
	Field Survey 2 Explanation of Draft Report ↓ 'Outline Design' Sub-contract w/LC Home Office; Prop. Tender Documents	○	○	○		○		
	Field Survey 3 Explanation of Drs & Tender Documents ↓ Final Report	○	○	○		○		
Appraisal & Approval	Appraisal of Project ↓ Inter-Ministerial Consultation ↓ Preparation of Draft Memorandum ↓ Approval by the Cabinet		○					
Implementation	EM (EM: Exchange of Memorandum)	○	○					
	GA (GA: Grant Agreement)	○		○				
	Bidding Arrangement	○						*
	Agmt Agreement ↓ Verification	○		○	○			
	Issuance of BDA (BDA: Bank Disbursement Authorization)	○			○			*
	Contract Content	○		○	○	○		
	Detailed Design & Tender Documents ↓ Approval by Recipient Government ↓ Preparation for Tender	○		○	○	○	○	
	Tendering & Evaluation	○		○	○	○	○	
	Contract/Procurement Contract	○		○	○	○	○	
	Contract/Procurement ↓ Completion Certificate by Recipient Government	○		○	○	○	○	
	Operation ↓ Post Evaluation Study	○		○				
	Evaluation & Follow up	Ex-Post Evaluation ↓ Follow up	○	○	○			

* The field survey 3 and appraisal process will be implemented simultaneously.

Jeet

Flow of Funds for Implementation under the Japan's Grant Aid for Community Empowerment

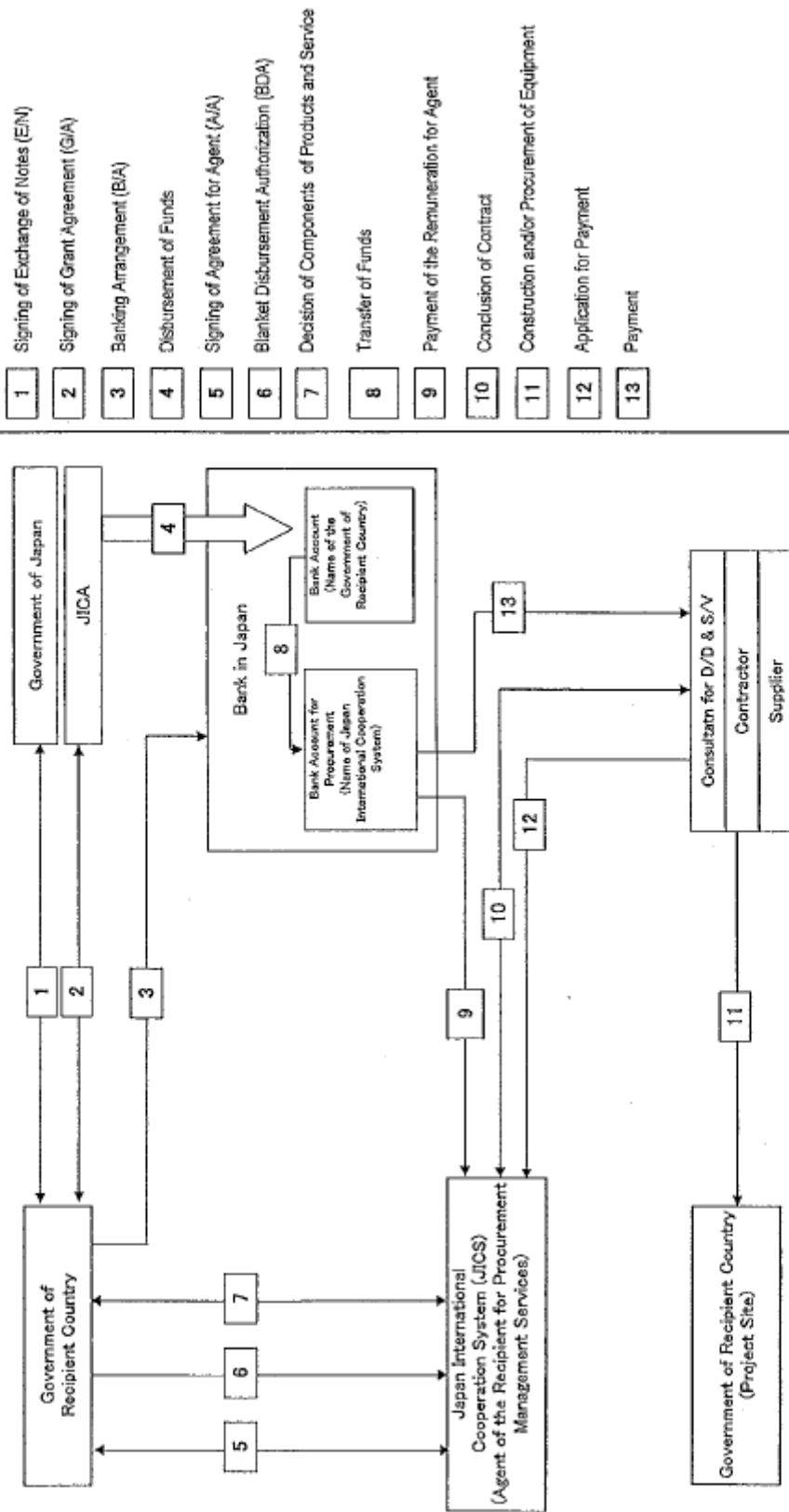

Leak
K.h

Major Undertakings to be Taken by Each Government

No.	Items	To be covered by Grant Aid	To be covered by Recipient Side
1	To secure land		●
2	To clear level and reclaim the site when needed		●
3	To construct gates and fences in and around the site		●
4	To Construct the Parking lot		●
5	To construct roads		
	1) Within the site	●	
	2) Outside the site		●
6	To construct the building	●	
7	To provide facilities for the distribution of electricity, water supply, drainage and other incidental facilities		
	1) Electricity		
	a. The distributing line to the site		●
	b. The drop wiring and internal wiring within the site	●	
	c. The main circuit breaker and transformer	●	
	2) Water Supply		
	a. The city water distribution main to the site		●
	b. The supply system within the site (receiving and elevated tanks)	●	
	3) Drainage		
	a. The city drainage main (for storm sewer and others to the site)		●
	b. The drainage system (for toilet sewer, ordinary waste, storm drainage and others) within the site	●	
	4) Gas Supply		
	a. The city gas main to the site		●
	b. The gas supply system within the site	●	
	5) Telephone System		
	a. The telephone trunk line to the main distribution frame/panel (MDF) of the building		●
	b. The MDF and the extension after the frame/panel	●	
	6) Furniture and Equipment		
	a. General furniture		●
	b. Project equipment	●	
8	To bear the commissions to the Japanese bank for banking services based upon B/A		●
9	To ensure prompt customs clearance and to assist internal transportation in the recipient country and to assist internal transportation therein of the products		●
10	To ensure that customs duties, internal taxes and other fiscal levies which may be imposed in the recipient country with respect to the purchase of the Components as well as the employment of the Agent be exempted/be borne by its designated authority without using the Grant and its accrued interest.		●
11	To accord Japanese nationals and / or nationals of third countries, including such nationals employed by the Agent, whose services may be required in connection with the supply of the Components such facilities as may be necessary for their entry into the recipient country and stay therein for the performance of their work (The term "nationals" whenever used in the G/A means Japanese physical persons or Japanese juridical persons controlled by Japanese physical persons in the case of Japanese nationals, and physical or juridical persons of third countries in the case of nationals of third countries.)		●
12	To ensure that the Facilities and the Components be maintained and used properly and effectively for the implementation of the Project		●
13	To bear all the expenses, other than those covered by the Grant and its accrued interest, necessary for the implementation of the Project		●
14	To give due environmental and social consideration in the implementation of the Project		●

(B/A: Banking Arrangement, G/A: Grant Agreement)

4-2 現地調査 II-2 (概略設計概要説明)

MINUTES OF DISCUSSIONS
ON
PREPARATORY SURVEY
(EXPLANATION OF DRAFT REPORT)
ON
THE PROJECT FOR
THE CONSTRUCTION OF SECONDARY SCHOOLS
IN NAMPULA PROVINCE
IN THE REPUBLIC OF MOZAMBIQUE

From April 2011 to May 2011, Japan International Cooperation Agency (hereinafter referred to as "JICA") had conducted a field survey as a part of the Preparatory Survey on the Project for the Construction of Secondary Schools in Nampula Province (hereinafter referred to as "the Project") in the Republic of Mozambique (hereinafter referred to as "Mozambique"). Based on the results of the first field survey and subsequent technical examinations conducted in Japan, JICA prepared the Draft Preparatory Survey Report.

In order to explain the contents of the Report and discuss with the officials concerned of the Government of Mozambique, JICA sent the Survey Team (hereinafter referred to as "the Team"), which was headed by Mr. Nobuaki MIYATA, Visiting Senior Advisor, JICA, and is scheduled to stay in Mozambique from December 15 to 22, 2011.

The Team had a series of discussions with the Mozambican officials concerned and conducted this second field survey.

As a result of discussions, both sides have confirmed the main items described in the attached sheets.

Maputo, Mozambique
December 21, 2011

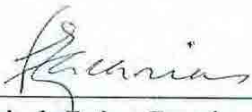

Ms. Maria de Fatima Zacarias
Permanent Secretary
Ministry of Education,
The Republic of Mozambique

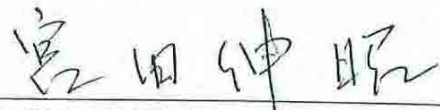

Mr. Nobuaki Miyata
Leader
Preparatory Survey Team
Japan International Cooperation Agency

ATTACHMENT

1. Contents of the Draft Report

The Mozambican side agreed and accepted in principle the contents of the Draft Preparatory Survey Report as explained by the Team.

2. Project Sites

The Mozambican side agreed that the candidate schools to be covered by the Project would be those four (4) schools on the list below. The Mozambican side understood that the selection of final candidate schools would be made within the budget limitation of the Government of Japan. The order of priority shown below will be taken into consideration when selecting the final candidate schools.

Prioritized List of Candidate Schools

No.	Area	Site
1	Cidade de Nampula	Natikire
2	Namapa-Erati	Namapa sede
3	Memba	Memba sede
4	Nacala-a-Velha	Nacala-a-Velha

3. Components and Facilities to be Covered by the Project

Both sides agreed on the list of components and facilities for each candidate school to be covered by the Project as shown in ANNEX-1. The Mozambican side agreed that the Japanese side would make a final decision on this matter through final adjustment in Japan. The Mozambican side understood there is a possibility to adjust the volume of components according to the budget approved by Government of Japan. In case the volume of components should be reduced, the first component to be adjusted is the covered sports field with changing rooms at the site of Nacala-a-Velha.

4. Japan's Grant Aid Scheme and Major Undertakings

The Mozambican side understood the Japan's Grant Aid Scheme described in ANNEX 4, ANNEX 5, ANNEX 6, ANNEX 7 and ANNEX 8 of the Minutes of Discussions signed by both parties on April 21, 2011, and the Mozambican side assured that it shall take necessary measures as indicated in ANNEX-2 of this Minutes of Discussions.

5. Final Report of the Preparatory Survey

JICA will finalize the Report in accordance with the result of discussions and forward it to the Government of Mozambique around April, 2012.

6. Project Cost Estimation

The Japanese side showed the Project Cost Estimation to the Mozambican side based on the

field surveys as described in ANNEX-3. The Mozambican side understood that it was not final at this stage and would be set and approved by the Government of Japan after thorough examinations.

7. Confidentiality of the Information Related to the Project

Both sides confirmed that all information related to the Project including design documents of facilities, furniture and equipment shall not be released to any outside parties before concluding all contracts for the Project. Furthermore, both sides agreed that the estimated cost of the Project as described in ANNEX-3 shall never be duplicated or released to any outside parties before concluding all contracts for the Project.

8. Other Relevant Issues

8-1. Water Supply

(1) Water Source Establishment

Both sides agreed that the Mozambican side would dig wells at each site and would submit the results of borehole works, water quantity tests (step drawdown test, constant discharge test, and recovery test) and water quality tests to JICA Mozambique Office by the end of July 2012.

(2) Options to be Taken Based on the Water Source Establishment

- a. In case the water quantity is insufficient, the Mozambican side agreed on applying non-flush toilet for each site since the toilet requires the most amount of water. The Mozambican side agreed on taking responsibility for preparing alternative water supply to the other facilities so that construction designs except toilet would not be changed.
- b. In case the water quality is insufficient, the Mozambican side agreed on adopting the chlorination or bringing bottles of potable water by each student.

8-2. Allocation of Necessary Budget and Personnel

The Mozambican side assured to allocate necessary budget and personnel for the proper operation and maintenance of the facilities to be covered by the Project.

8-3. Relocation of the Site of Cidade de Nampula (Natikire site)

Both sides agreed on the change of the site location of Cidade de Nampula (Natikire site) as shown in ANNEX-5. Mozambican side assured to submit the official document which confirms the provision for the relocated site of Cidade de Nampula to JICA Mozambique office by January 2012.

8-4. Proper Use and Maintenance

Both sides understood that proper use and maintenance of the facilities was indispensable for their long-term use. The Mozambican side assured the Team that it would facilitate the proper use and maintenance of the facilities in the schools to be covered by the Project with



the active involvement of concerned parties such as the Provincial Directorates of Education and Culture (DPEC), the District Services for Education, Youth and Technology (SDEJTs), principals of the schools, and other concerned organizations.

8-5. Way Forward

Japanese side will inform the Mozambican side of the approval by the Cabinet of Japan as immediately as possible through JICA Mozambique Office.

ANNEX-1 Components and Facilities to be Covered by the Project

ANNEX-2 Major Undertakings by Mozambican Side

ANNEX-3 Project Cost Estimation

ANNEX-4 Schedule of the Project

ANNEX-5 Location of the Project Site in Cidade de Nampula

ANNEX-1 Components and Facilities to be Covered by the Project

Candidate Sites (Areas) (in order of priority)		Components (1st priority)								(2nd priority)	
		Facilities								Equi p- ment	Facilities
		Administration Block	3 Classroom Block	4 Classroom Block	Multi-purpose Block	Sanitary Block (Large)	Sanitary Block (Small)	Guard House	Furniture for facilities of priority A	Covered Sports Field with Changing Room	
1	Natikire (Cidade de Nampula)	Priority (No. of blocks)	A (1)	A (1)	A (4)	A (1)	A (1)	-	A (1)	A	B-1 (1)
2	Namapa sede (Namapa-Erati)	Priority (No. of blocks)	A (1)	A (2)	A (1)	A (1)	-	A (1)	A (1)	A	B-2 (1)
3	Memba sede (Memba)	Priority (No. of blocks)	A (1)	A (2)	A (1)	A (1)	-	A (1)	A (1)	A	B-3 (1)
4	Nacala-a-Velha (Nacala-a-Velha)	Priority (No. of blocks)	A (1)	A (2)	A (1)	A (1)	-	A (1)	A (1)	A	B-4 (1)

The above items to be covered by the Project could be revised and adjusted upon the result of the detailed design, the results of bidding, etc., during the project implementation stage.

R *N. Silva*

ANNEX-2 Major Undertakings by Mozambican Side

1. Works to be done by the Mozambican Side

Candidate Sites (Areas)	Natikire (Cidade de Nampula)	Namapa sede (Namapa-Erati)	Memba sede (Memba)	Nacala-a-Velha (Nacala-a-Velha)
A. Works to be done prior to the tender notice for the first batch of the Project				
1 Acquisition of Environmental License	Y	Y	Y	Y
2 Acquisition of the project approval by the local authorities	Y (Nampula City)	Y (DPOPH)	Y (DPOPH)	Y (DPOPH)
3 Drilling for securing of water supply source	Y	Y	Y	Y
B. Works to be done by the commencement of the construction work under the Project				
4 Removal and uprooting of existing trees	Y	-	Y	Y
5 Removal of vegetation and grading of the construction area	Y (Approx.1.8 ha)	Y (Approx.1.7 ha)	Y (Approx.1.7 ha)	Y (Approx.1.7 ha)
6 Demolition of existing temporary structures within the construction area	-	-	-	Y (5 shed, to be evacuated)
7 Construction of temporary access road for construction vehicles	Y (Gravel paving, approx.50m)	Y (Gravel paving, approx.68m)	Y (Gravel paving, approx.90m)	Y (Gravel paving, approx.276m)
C. Works to be done by the completion of the construction work under the Project				
8 Provision of facility for electricity distribution *1	Y	Y	Y	Y
9 Provision of facility for water supply *2	Y	Y	Y	Y
D. Works to be done after the handover of the facilities under the Project				
10 Construction of perimeter fence and gates	Y (Approx.820m)	Y (Approx.690m)	Y (Approx.700m)	Y (Approx.800m)
11 Landscaping (sodding)	Y (Approx. 2,000m ²)	Y (Approx. 1,100m ²)	Y (Approx. 1,200m ²)	Y (Approx. 1,400m ²)
12 Supply of IT equipment for computer rooms	Y	Y	Y	Y
13. Supply of laboratory equipment for science labs	Y	Y	Y	Y

Y: Necessary DPOPH: Provincial Directorates of Public Works & Housing

Remarks:

*1 To extend MT (middle tension) power line from the nearest distribution points to the sub-station which will be provided by Japanese side, and make a connection to the transformer.

*2 All facilities up to the water reservoir tank, which will be provided by the Japanese side, shall be included. In case of well water system, installation of a well pump and its' automatic/manual control system, plumbing to the water reservoir tank and connection to it, shall be included. Power supply to the pump will be done by the Japanese side.

R N. Lu

2. Major undertakings to be done by the Mozambican Side

In addition to the items listed in the above table, the following undertakings are to be taken by the Mozambican side:

- 1) To construct external facilities which are not included in the scope of Japanese assistance, such as playground, planting, gate and fences,
- 2) To procure equipment, supplies, utensils, furniture and fittings which are not included in the scope of Japanese assistance,
- 3) To bear the commissions to the Japanese bank for banking services based upon the Banking Arrangement for the Project,
- 4) To ensure prompt customs clearance and to assist internal transportation in Mozambique and to assist internal transportation therein of the products,
- 5) To ensure that customs duties, internal taxes, including value added tax, and other fiscal levies which may be imposed in Mozambique with respect to the purchase of the Components as well as the employment of the Agent be borne by its designated authority without using the Grant and its accrued interest,
- 6) To prepare an appropriate amount of budget to substitute Value Added Tax with respect to the supply of products and services for the Project,
- 7) To accord Japanese nationals and/or nationals of third countries, including such nationals employed by the Agent, whose services may be required in connection with the supply of the Components such facilities as may be necessary for their entry into Mozambique and stay therein for the performance of their work,
- 8) To ensure that the Facilities and the Components be maintained and used properly and effectively for the implementation of the Project,
- 9) To bear all the expenses, other than those covered by the Grant and its accrued interest, necessary for the implementation of the Project, and
- 10) To give due environmental and social consideration in the implementation of the Project.

 Niba

ANNEX-5 Location of the Project Site in Cidade de Nampula



- NP01: S15°05'03.8" E39°11'39.5"
- NP02: S15°05'03.9" E39°11'27.1"
- NP03: S15°04'57.5" E39°11'27.3"
- NP04: S15°04'58.1" E39°11'40.8"

[Handwritten signature]