

## Outline of Japan Environmental Management Association for Industry

**Brief history**  
 Aug. 1963 Established as Air Pollution Control Industry Association (APCIA)  
 Nov. 1966 Changed name to Industrial Pollution Control Association of Japan (IPCAJ)  
 \* 1967 Enactment of Pollution Countermeasures Basics Act  
 Mar. 1987 Designated as organization for national qualification examinations of pollution control managers



- \* Jun. 1992 Convocation of the Earth Summit (Rio Summit)
- Oct. 1993 Changed name to Japan Environmental Management Association for Industry
- \* Nov. 1993 Enactment of Environmental Basics Act
- Oct. 1995 Established Japan LCA Forum (LCA: Life Cycle Assessment Society)
- Sep. 1997 Started evaluation and registration of Environment Management System Auditors
- Apr. 1998 Started LCA National Project (~2005)
- Dec. 1999 Started Eco-Products Exhibition
- Apr. 2002 Started Type III Environmental Declarations (Eco-leaf) program
- Apr. 2002 Started LCA consulting business
- Jun. 2004 Started public operation of Japan LCA Database
- Apr. 2006 Started sales of JEMAI-LCA PRO (LCA calculation software)
- Sep. 2006 Established Joint Article Management Promotion-consortium (JAMP)
- Dec. 2006 Started registration and assistance of waste/recycle governance
- May 2007 Started assistance for registration of REACH
- Jul. 2007 Started project for skill-up of environmental practitioners
- Apr. 2009 Started promotion of Carbon Footprint project
- Oct. 2010 Scheduled to release new LCA software

Copyright © 2010 JEMAI

## What is ECOLEAF?

The diagram illustrates the ECOLEAF process. It starts with a product (a camera) and a registration number (No. CP-07-001). The process involves registration on the website [www.pokka.co.jp/company/new/2007/070521\\_01.htm](http://www.pokka.co.jp/company/new/2007/070521_01.htm). The resulting product is labeled with the ECOLEAF logo. The website [www.jemai.or.jp/eco/leaf/](http://www.jemai.or.jp/eco/leaf/) provides detailed data for each registration number.

Indicates that it is a program participation product and the ECOLEAF registration number.

Copyright © 2010 JEMAI

# Current Status and Issues of Carbon Footprint Program in Japan

Akikatsu Ishizuka  
 Deputy General Manager  
 Center of Product and Environmental Aspects  
 Japan Environmental Management Association for Industry

## Environmental Labels

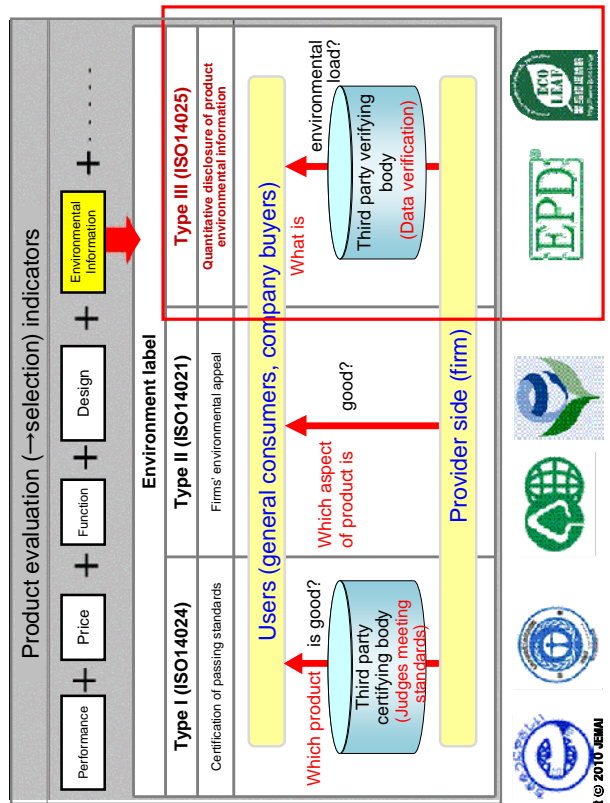

Copyright © 2010 JEMAI

## In pursuit of a “Low-Carbon Japan”

- As part of the partial amendment of Law Concerning the Promotion of the Measures to Cope with Global Warming published in June 2008, Article 20-6 provides that it is obliged to make efforts in promotion of visualization of GHG emissions.
- The “Fukuda Vision” entitled pursuit of a “Low-GHG Society - Japan” launched implementation of carbon footprint program.
- Government establishes Strategy Conference on “Visualization of GHG emissions” to promote awareness of the effects of greenhouse gases on people and industry and to promote lifestyle reforms.



(Reference) Law Concerning the Promotion of the Measures to Cope with Global Warming as amended  
 Article 20-6. The operator shall, when it manufactures, imports, sells or provides (“manufactures”) products or services used by the people in their daily lives (“daily necessities”), manufactures products or services with less greenhouse gas emissions and endeavor to provide precise and appropriate information on emission of greenhouse gas involved in the use of the daily necessities.

## Greenhouse Gases subject to Carbon Footprint Program

No.	Species	Chemical Formula	Global Warming Potential (100-yr)
1	Carbon dioxide	CO <sub>2</sub>	1
2	Methane	CH <sub>4</sub>	21
3	Nitrous oxide	N <sub>2</sub> O	310
4	HFC-23	CHF <sub>3</sub>	11,700
5	HFC-32	CH <sub>2</sub> F <sub>2</sub>	650
6	HFC-41	CH <sub>3</sub> F	150
7	HFC-125	C <sub>2</sub> H <sub>5</sub> F <sub>5</sub>	2,800
8	HFC-134	C <sub>2</sub> H <sub>2</sub> F <sub>4</sub>	1,000
9	HFC-134a	CH <sub>2</sub> FCF <sub>3</sub>	1,300
10	HFC-143	C <sub>2</sub> H <sub>3</sub> F <sub>5</sub>	300
11	HFC-143a	C <sub>2</sub> H <sub>3</sub> F <sub>5</sub>	3,800
12	HFC-152a	C <sub>2</sub> H <sub>4</sub> F <sub>2</sub>	140
13	HFC-227ea	C <sub>3</sub> HF <sub>7</sub>	2,900
14	HFC-236fa	C <sub>3</sub> H <sub>2</sub> F <sub>6</sub>	6,300
15	HFC-245fa	C <sub>3</sub> H <sub>3</sub> F <sub>5</sub>	3,380
16	HFC-43-10mee	C <sub>3</sub> H <sub>2</sub> F <sub>10</sub>	1,300
17	Perfluoromethane (PFC-14)	CF <sub>4</sub>	6,500
18	Perfluoroethane (PFC-116)	C <sub>2</sub> F <sub>6</sub>	9,200
19	Perfluoropropane (PFC-218)	C <sub>3</sub> F <sub>8</sub>	7,000
20	Perfluorobutane (PFC-31-10)	C <sub>4</sub> F <sub>10</sub>	7,000
21	Perfluorocyclobutane (PFC-31-11)	c-C <sub>4</sub> F <sub>8</sub>	8,700
22	Perfluoropentane (PFC-41-12)	C <sub>5</sub> F <sub>12</sub>	7,500
23	Perfluorohexane (PFC-51-14)	C <sub>6</sub> F <sub>14</sub>	7,400
24	Sulphur hexafluoride	SF <sub>6</sub>	23,900

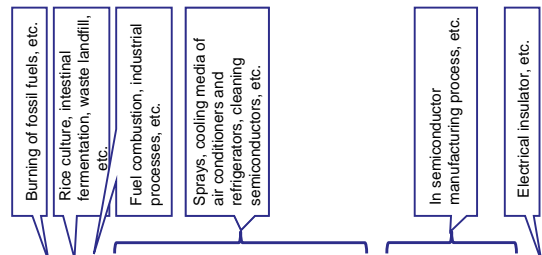

100-year GMPs from IPCC 1996 Second Assessment Report (SAR)

## Greenhouse Gases Subject to Carbon Footprint Program

### Greenhouse gas calculations

Item	Contents
Kinds of greenhouse gases	6 kinds: Carbon dioxide (CO <sub>2</sub> ), methane (CH <sub>4</sub> ), nitrous oxide (N <sub>2</sub> O), sulfur hexafluoride (SF <sub>6</sub> ), hydrofluorocarbons (HFCs), perfluorocarbons (PFCs) (Greenhouse gases subject to the Kyoto Protocol)
Emission sources	Including natural origin (livestock emissions and agricultural process emissions)
GWP (*)	100-year global warming potentials (GWPs) from IPCC Second Assessment Report (SAR) (Standards for calculating national emissions in Kyoto Protocol)

(\*)GWP (Global Warming Potential) : The coefficient of greenhouse effect of greenhouse gases as compared to the effect of carbon dioxide.  
 However, as to kinds of greenhouse gases, all gases listed in the IPCC SAR will be included, for example, by periodical review subject to further international discussion. In regard to GWP applicable to greenhouse gases other than CO<sub>2</sub>, it is necessary to provide new rules for periodical review reflecting renewal of IPCC report data.

## What is Program for Carbon Footprint of Products (CFP)?

Carbon Footprint of Products (CFP)

### Anti-global-warming measures by visualization of greenhouse gas emissions

The Carbon Footprint Program divides product lifecycles into “procurement of materials,” “production,” “distribution and sales,” “use and maintenance” and “disposal and recycling.” Greenhouse gases emitted in these five phases to indicate CO<sub>2</sub> volumes.

- Calculation by lifecycle assessment method (ISO14040, 14044)
- Communication tools using Type III Environment Labeling (ISO14025)

### Significance for operators

- By visualizing emissions across supply chain, grasp the high reduction point. By comprehensive reduction beyond operators, realize the total optimization.
- Informing the consumers over initiatives for reducing own environmental impacts.

### Significance for consumers

- Consumers' awareness of CO<sub>2</sub> emissions
- Provision of appropriate information for reducing environmental impacts.

### Process of CFP Pilot Project (fiscal 2009)

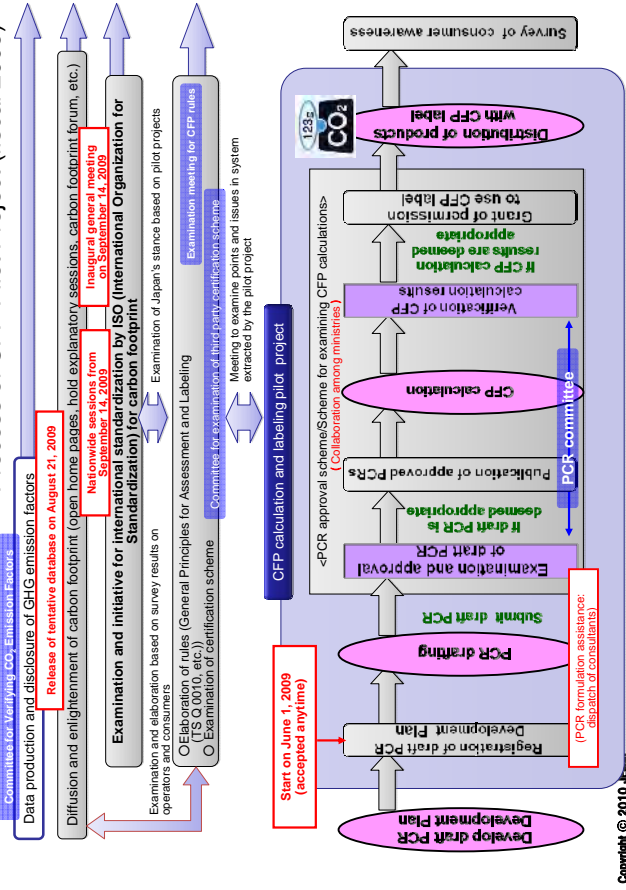

### How to Apply for CFP Label in the Calculation and Labeling Pilot Program

#### < 1. Application for registration of Draft PCR Development Plan >

First, the operators requesting PCR compilation and approval submit an "Application Form for Registration of Draft PCR Development Plan" to the secretariat of the CFP Pilot Project (Japan Environmental Management Association for Industry) and register the "Draft PCR Development Plan," which will be published on the association's home page (<http://www.cfp-japan.jp>). The time needed from application to registration is about one to two weeks.

#### < 2. Application for PCR Approval >

Operators desiring PCR approval submit the "Draft PCR developed on the basis of the "Draft PCR Development Plan" and "Application Form for PCR Approval" to the secretariat of CFP Pilot Project (Japan Environmental Management Association for Industry). The "PCR" will be modified to reflect the opinions gathered via the home page and refer to the opinions. Then, the Draft PCR will be examined by the PCR Committee after PCR review. The approved Draft PCR will be published on the home page as the approved "PCR." The time needed from application to approval is about two to four weeks.

#### < 3. Application for CFP Verification >

Operators desiring calculation and labeling of carbon footprint shall calculate CFP based on the PCR of the product in question and submit the calculation results by "an Application Form for CFP Verification" to the secretariat of CFP Pilot Project (Japan Environmental Management Association for Industry). CFP calculation results will be verified by the PCR Committee and, if appropriate, the permission to use the CFP label will be granted to the applicant. The time needed between application and approval is about two to four weeks.



### What is PCR, the product category rules?

- LCA brings largely differing results for the same product due to functional units, system boundaries, etc.
- PCR is an abbreviation of Product Category Rules for evaluating products by LCA.

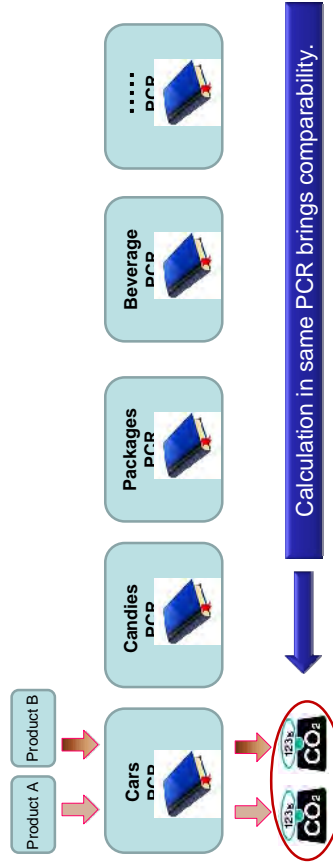

### Points of Carbon Footprint of Products (CFP) Pilot Project

Indicate CO<sub>2</sub> emission for a product/service over the lifecycle.

- Make standard based on product comparisons.
- Establish verification method for CFP calculation results based on standards
- Provide calculation rule and calculation database (GHG Emission Factors)
- Labeling contents and methods for calculation results.
  - Handling of intermediate products (B to B)
  - Handling of services

**Develop PCR**  
(Product Category Rule)

## List of approved Product Category Rules (PCRs) in Fiscal 2009

In fiscal 2009, 45 PCRs were approved.

No.	PCR ID	PCR Name	No.	PCR ID	PCR Name
1	PA-AA-01	Rice	21	PA-AR-01	Files and Binders
2	PA-AB-01	Repeased Oil	22	PA-AS-01	Writing Instruments
3	PA-AC-01	Powder Detergent	23	PA-AT-01	Lamps for General Lighting
4	PA-AD-01	Publishing Printing and Commercial Printing	24	PA-AU-01	Portable Sealed Secondary Cells and Batteries
5	PA-AE-01	Candy	25	PA-AV-01	Universal Steel Pipe Pile
6	PA-AF-01	Pre-Sensitized Plates for Lithographic Printing	26	PA-AW-01	Flowers
7	PA-AG-02	(Renewal)Pre-Sensitized Plates for Lithographic Printing	27	PA-AX-01	ICT Hosting Service
8	PA-AH-01	Potato Chips	28	PA-AY-01	Roadbed Material made from Inorganic Sludge
9	PA-AI-01	Cooked and Sealed Rice	29	PA-AZ-01	Paper Products for Stationery
10	PA-AJ-01	Hams and Sausages	30	PA-BA-01	Fire Extinguisher

## List of Licensed Products for CFP Label in Fiscal 2009

In fiscal 2009, 56 products were licensed to use CFP label.

No.	Verification ID	Product name	Company name	CO <sub>2</sub>	No.	Verification ID	Product name	Company name	CO <sub>2</sub>
1	CV-AA-001	TOPVALU GREEN EYE specially-cultivated rice	AEON Co., Ltd.	6.4 kg	13	CV-AG-002	Potato Chips Konsumer punch	Calbee Co., Ltd.	306g
2	CV-AA-002	TOPVALU GREEN EYE specially-cultivated rice (Akitakomachi home-delivery gift package)	AEON Co., Ltd.	6.3 kg	14	CV-AH-001	TOPVALU rice 200g	AEON Co., Ltd.	0.5kg
3	CV-AA-003	Akitakomachi	AEON Co., Ltd.	6.7 kg	15	CV-AH-002	TOPVALU rice 200g*3 packages	AEON Co., Ltd.	1.6kg
4	CV-AA-004	Akitakomachi(home-delivery gift package)	AEON Co., Ltd.	6.6 kg	16	CV-AH-003	TOPVALU rice 200g*5 packages	AEON Co., Ltd.	2.8kg
5	CV-AB-001	TOPVALU Candela oil	AEON Co., Ltd.	1.4 kg	17	CV-AN-001	Sodasundusu 500ml	Earthsupport Co., Ltd.	606g
6	CV-AB-002	TOPVALU Candela oil gift package	AEON Co., Ltd.	9.1 kg	18	CV-AN-002	Sodasundusu 20	Earthsupport Co., Ltd.	164kg
7	CV-AC-001	TOPVALU Super Clean White	AEON Co., Ltd.	6.3 kg	19	CV-AN-003	Sodasundusu II	Earthsupport Co., Ltd.	514kg
8	CV-AC-002	TOPVALU Super Clean White gift package	AEON Co., Ltd.	5.1kg	20	CV-AI-001	Jo-kyu-mori-no-kaori sausage 52g	Nipponham Co., Ltd.	638g
9	CV-AA-005	Koshikari made in Ship perf.	Rikusenjo Umakawa Co., Ltd.	7.7kg	21	CV-AI-002	Jo-kyu-mori-no-kaori sausage 52g*3 packages	Nipponham Co., Ltd.	1.28kg
10	CV-AI-001	Salade rice cookie	Kameda-take Co., Ltd.	537g	22	CV-AI-003	Jo-kyu-mori-no-kaori sausage 53g	Nipponham Co., Ltd.	312g
11	CV-AE-001	Kanro candy	Kanro Co., Ltd.	584g	23	CV-AI-004	Jo-kyu-mori-no-kaori sausage 53g*3 packages	Nipponham Co., Ltd.	925g
12	CV-AG-001	Potato Chips Usurho-ji	Calbee Co., Ltd.	306g	24	CV-AI-005	Jo-kyu-mori-no-kaori sausage 52g	Nipponham Co., Ltd.	422g

## List of approved Product Category Rules (PCRs) in Fiscal 2009

No.	PCR ID	PCR Name	No.	PCR ID	PCR Name
31	PA-BB-01	Paper Containers, Packaging and Wrapping	41	PA-BL-01	Towel Products
32	PA-BC-01	Plastic Container and Packaging	42	PA-BM-01	Waste Incineration and Landfill (Intermediate Service)
33	PA-BD-01	Metallic Containers and Packaging	43	PA-BN-01	Hand-made Washi
34	PA-BE-01	Glass Container (Intermediate Goods)	44	PA-BO-01	Stationery Products and Office Supplies
35	PA-BF-01	Vegetables and Fruits	45	PA-BP-01	UV Germicidal Irradiation Air Purifier

36	PA-BG-01	Pallet for Cargo and Transportation
37	PA-BH-01	Instant Noodles
38	PA-BI-01	Teleconference Systems using Interactive White Board
39	PA-BJ-01	Raw Bananas
40	PA-BK-01	Reuse Battery

## List of Licensed Products for CFP Label in Fiscal 2009

In fiscal 2009, 56 products were licensed to use CFP label.

No.	Verification ID	Product name	Company name	CO <sub>2</sub>	No.	Verification ID	Product name	Company name	CO <sub>2</sub>
25	CV-AS-001	Oh-hik marker Kowakira-pen	Shochihata Co., Ltd.	167g	37	CV-AO-003	E-recycling	Sanshin-kakou Co., Ltd.	148kg
26	CV-AI-006	Jo-kyu-mori-no-kaori sausage 111g	Nipponham Co., Ltd.	702g	38	CV-AO-004	Power selahigselection	Sanshin-kakou Co., Ltd.	137kg
27	CV-AI-007	Jo-kyu-mori-no-kaori sausage 111g*2	Nipponham Co., Ltd.	1.40kg	39	CV-AO-005	Power selahigselection	Sanshin-kakou Co., Ltd.	136kg
28	CV-AI-008	Jo-kyu-mori-no-kaori Memo-han 52g	Nipponham Co., Ltd.	428g	40	CV-AO-006	Power selahigselection	Sanshin-kakou Co., Ltd.	133kg
29	CV-AF-001	Digital Tamal Plate	Fujifilm Co., Ltd.	216g	41	CV-AI-001	Eco-rite	Soil Management Japan Co., Ltd.	177kg
30	CV-AO-001	Play pro tray	Sanshin-kakou Co., Ltd.	305kg	42	CV-AM-001	Nestle Exela cup coffee set cups	Nestle Japan Co., Ltd.	504g
31	CV-AX-001	ICT hosting Service	Nihon-Uinays Co., Ltd.	4.53t	43	CV-AI-008	Jo-kyu-mori-no-kaori Memo-han 53g	Nipponham Co., Ltd.	471g
32	CV-AD-001	Uniform women jacket	Chikuma Co., Ltd.	124kg	44	CV-AI-010	Jo-kyu-mori-no-kaori rouse-han 53g	Nipponham Co., Ltd.	462g
33	CV-AD-002	Uniform women vest	Chikuma Co., Ltd.	7.0kg	45	CV-AI-011	Jo-kyu-mori-no-kaori rouse-han 49g*3	Nipponham Co., Ltd.	1.04kg
34	CV-AO-003	Uniform women Skirt	Chikuma Co., Ltd.	7.0kg	46	CV-AK-004	Schooler right desk	Ohkura Onsen Co., Ltd.	236kg
35	CV-AO-004	Uniform women Pants	Chikuma Co., Ltd.	9.3kg	47	CV-AK-005	Schooler right Chair	sesakuyo Omara Co., Ltd.	132kg
36	CV-AO-002	E-recycling	Sanshin-kakou Co., Ltd.	193kg	48	CV-BC-001	MMP pallet	MMPPlastics Co., Ltd.	96.6kg

In fiscal 2009, 56 products were licensed to use CFP label.

No.	Verification ID	Product name	Company name	CO <sub>2</sub>
49	CV-BG-002	MWP pallet	MMPlastics Co.,Ltd.	140kg
50	CV-BG-003	MMP pallet	MMPlastics Co.,Ltd.	65.3kg
51	CV-BG-004	MWP pallet	MMPlastics Co.,Ltd.	96.4kg
52	CV-BG-005	MMP pallet	MMPlastics Co.,Ltd.	126kg
53	CV-BG-006	MWP pallet	MMPlastics Co.,Ltd.	182kg
54	CV-BG-007	MWP pallet	MMPlastics Co.,Ltd.	84.2kg
55	CV-BG-008	MMP pallet	MMPlastics Co.,Ltd.	128kg
56	CV-AW-001	meihin rose	MPS, Japan Co.,Ltd.	961g

As of April 27, 2010  
88 products had been approved.

## Permission to use CFP Label

Absolute CO<sub>2</sub> emission values are labeled in unified way. With a view to let consumers know about operators' efforts to achieve emission reductions, it is possible to label additional information such as reduction rate.

(1) Labeling carbon footprint of final consumables  
For final consumables, display pursuant to Figure 1.



(2) Labeling of carbon footprint of intermediate products  
For intermediate products, display is shown in Figure 2.

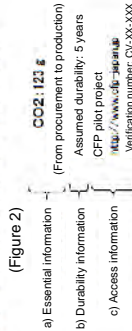

## Calculation of Carbon Footprint of Products

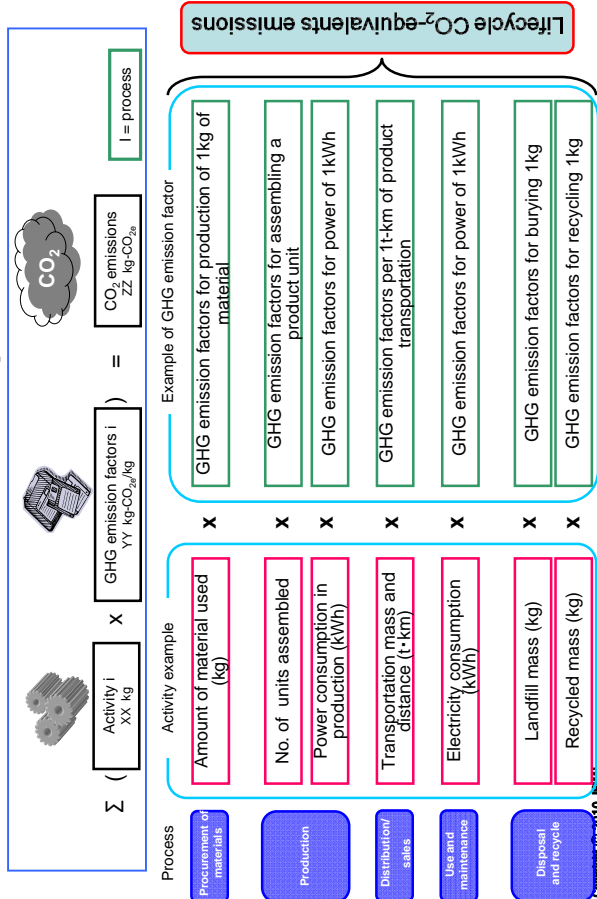

## Database of GHG Emission Factors for CFP Pilot Project

- Tentative database of GHG emission factors (ver.2.01) was released in October 2010 for use in the Carbon Footprint of Products Pilot Project. (842 data)
- This database was updated from first one (released in August 2009), and was created under the supervision of the National Institute of Advanced Industrial Science and Technology (AIST) and verified by the GHG Emission Factors Review Committee (Chairperson: Prof. Emeritus Hisashi Ishitani). This committee consists of third-party intellectuals.
- The database was developed by collecting and arranging data from various sources such as documents and research materials to support the CFP Pilot Project in FY 2009.

No.	Type	Industry	Name	Unit	GHG Emission (kg-CO <sub>2</sub> e/Unit)	Source	Scope	Note
1	Energy	Gas Industry	Combustion of city gas 13A	MJ	6.59E-02	"Instruction manual of comprehensive energy statistics/revised in 2007" (2009, RIETI) "GHG Emissions calculation manual Ver.2.4" (2009, MOE and METI)	-Raw materials mining -Production -Fuel burn	Higher heating value: 45.9MJ/Nm <sup>3</sup>
2	Energy	Gas Industry	Combustion of city gas 13A	Nm <sup>3</sup>	3.01E+00	"Instruction manual of comprehensive energy statistics/revised in 2007" (2009, RIETI) "GHG Emissions calculation manual Ver.2.4" (2009, MOE and METI)	-Raw materials mining -Material production -Fuel burn	Higher heating value: 45.9MJ/Nm <sup>3</sup>
3	Energy	Gas Industry	Combustion of city gas 13A	kg	3.55E+00	"Instruction manual of comprehensive energy statistics/revised in 2007" (2009, RIETI) "GHG Emissions calculation manual Ver.2.4" (2009, MOE and METI)	-Raw materials mining -Material production -Fuel burn	Higher heating value: 45.9MJ/Nm <sup>3</sup>
4	Energy	Mining Industry	Combustion of clued Oil	MJ	7.33E-02	"Survey report on the Comparison of Oil, LNG and Coal by LCA method" (1999, Japan Petroleum Energy Center) "Instruction manual of comprehensive energy statistics/revised in 2007" (2009, RIETI) "GHG Emissions calculation manual Ver.2.4" (2009, MOE and METI) "Survey report on fixed source to affect atmosphere environment in 2009" (2009, METI)	-Ore -Production -Use (Fuel burn)	Higher heating value: 38.2MJ/L
8	Transportation	Air cargo	International Air cargo	tkm	5.19E-01	"Air transport statistics investigation" (http://www.nipponair.jp/~statist/rokokku/koukaku.html)(X/M/L/T)	-Fuel mining -Service of International Air cargo	

RIETI: The Research Institute of Economy, Trade and Industry, MOE: Ministry of Environment, METI: Ministry of Economy, Trade and Industry, MELT: Minister of Land and Transportation

### Database on GHG Emission Factors (ver.2.01) for CFP Pilot Project

Process Data and Detail Information
1. Agriculture
2. Forestry
3. Fishery
4. Mining
5. Food
6. Beverage, Cigarette & Feed
7. Chemical Textiles
8. Wood products
9. Pulp & Paper
10. Chemical
11. Oil products & Coal products
12. Plastic products
13. Gum products
14. Tanned leather, related product & Fur
15. Cement & Ceramics
16. Iron & Steel
17. Non-Ferrous Metal
18. Metal products
19. Machinery & Others
20. Electricity Supply
21. Gas Supply
22. Heat Supply
23. Water supply, Sewage
24. Rail transportation
25. Road Freight
26. Ship Freight
27. Air passenger and Freight
28. Waste Disposal

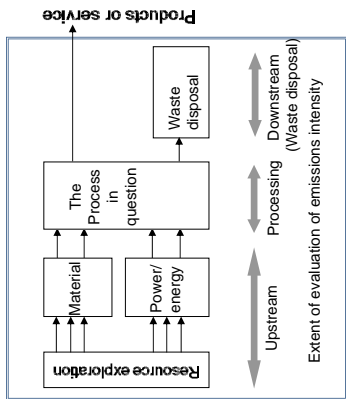

Figure: Extent of evaluation

<http://www.cfp-japan.jp/calculate/verify/data.html>

Copyright © 2010 JEMAI

### Distributed products with Carbon Footprint of Products (CFP) label

Press release from Shachihata Co., Ltd.

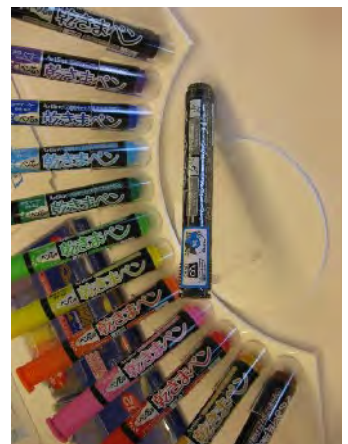

Copyright © 2010 JEMAI

### Distributed products with Carbon Footprint of Products (CFP) label

Press release from Nihon Hame Co., Ltd.



Copyright © 2010 JEMAI

### Eco-Products 2009 (Dec. 10-12, 2009)

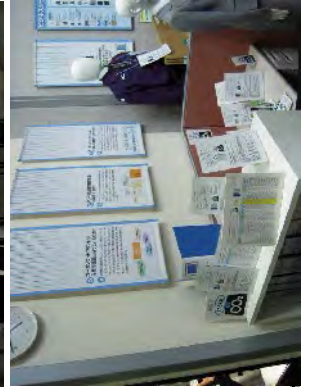
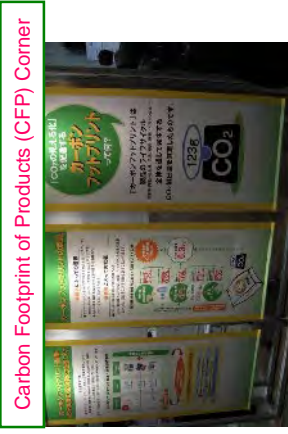

Copyright

## Eco-Products 2009 (Dec. 10-12, 2009)



Copyright © 2010 JEMAI

## Eco-Products 2009 (Dec. 10-12, 2009)



Copyright © 2010 JEMAI

## Major Issues and Responses as Seen in Program Operation in Fiscal 2009

Issues	Response to issues
Variety of labeling	Allow various types of labeling for the time being as tentative measures in the trial period. Examples: "Per unit volume," "per functional unit," "reduction volume" and "no value."
Treatment of sales process	Will not include the sales process in calculation and labeling while appropriate calculation methods for sales processes are being developed.
Comparison with other products	Full care must be taken to avoid comparison with other products and comparison beyond PCR.
Collection of primary data	Primary data will be the bases in regard to processes with high levels of contribution to the lifecycle. Allow secondary data to be used when contribution is low and it is difficult to collect primary data.
GHG emission factors	Revise the GHG emission factors (tentative version) published in fiscal 2009 from 220 cases to over 1,000 cases.

Copyright © 2010 JEMAI

## Proper Scope of Product Category Rules (PCRs)

- In the revision of current rules, avoid various segmented PCRs. For this purpose, to define scope of product category targeted by individual PCRs, it is a must to devise broader definitions while considering (1) functions and properties; (2) uses (professional use, consumer use, for example); (3) legal restrictions; and (4) other related standards (industry standards, for example).
- Proper product classification → Small classification or use of sub-categories in Japan Standard Commercial Classification

( An example of Japan Standard Commercial Classification )

Large classification	Foods, beverages and processed tobacco
Middle classification	Agricultural products
Small classification	Rice
Sub-category	Polished rice
Sub-sub-category	Domestic polished rice
6-digit classification	Wet Japonica polished rice

Copyright © 2010 JEMAI

## Concepts in calculating recycling effects

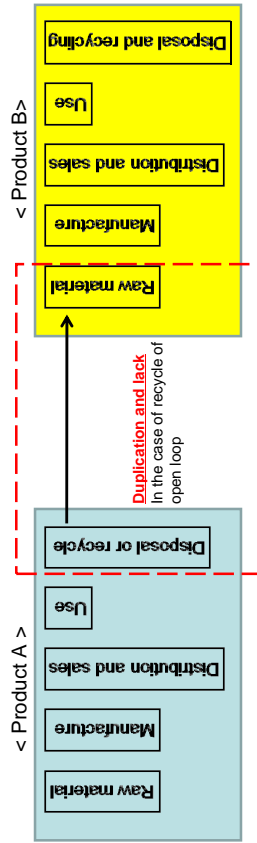

## Outline of Carbon Footprint of Products (CFP) Pilot Project Flow of CFP calculation and labeling

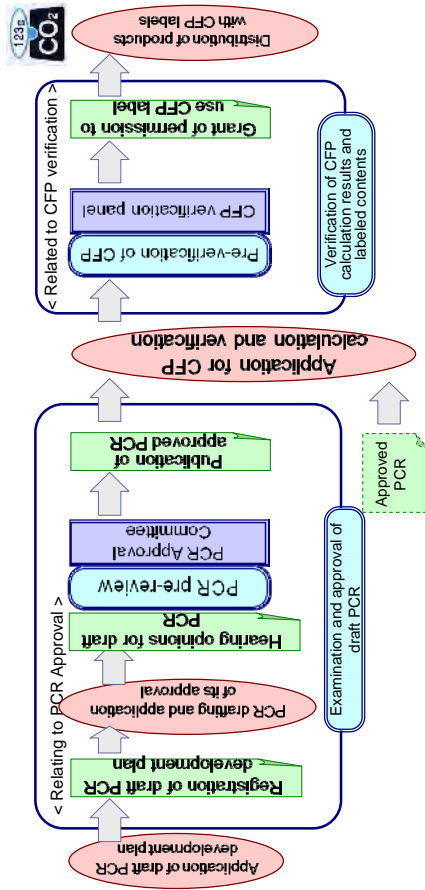

## Reference (HP of Carbon Footprint of Products (CFP) Pilot Project)

- A website is opened to fully inform the Carbon Footprint of Products (CFP) system and improve knowledge and understanding of operators and consumers.  
(Website address: <http://www.cfp-japan.jp>)
- Provide information for the whole program, including explanation of the Carbon Footprint Products (CFP) system, registration of Draft PCR plan, and publication of approved PCR.





November 2, 2010  
For TGO, Thailand

# LCA/CFP database in Japan

## - Development and dissemination -

Yasushi SHIRAISHI  
Japan Environment Management Association  
for Industry (JEMAI)



Copyright (C) 2010 JEMAI All Rights Reserved

1

A4-42

## Contents

1. LCA national project in Japan
2. Life Cycle Assessment Society of Japan
3. Eco-Design Promotion Project for small and medium-sized enterprises
4. Development of LCA database and software
5. Development of CFP database

Copyright (C) 2010 JEMAI All Rights Reserved

3

## Contents

1. LCA national project in Japan
2. Life Cycle Assessment Society of Japan
3. Eco-Design Promotion Project for small and medium-sized enterprises
4. Development of LCA database and software
5. Development of CFP database

Copyright (C) 2010 JEMAI All Rights Reserved

2

## History of LCA national project (FY1998-2010)

Funded by Ministry of Economy, Trade and Industry, Japan (METI)

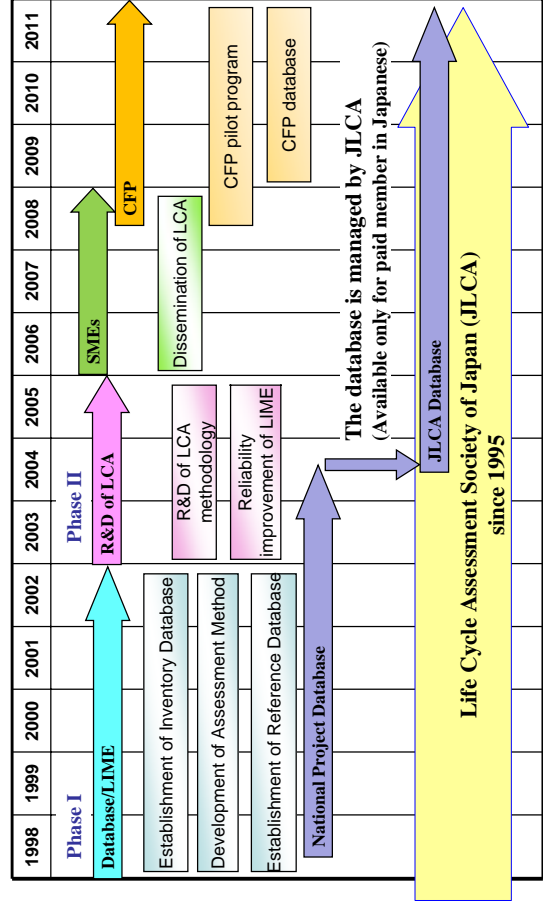

Copyright (C) 2010 JEMAI All Rights Reserved

4

# LCA Project Phase I. (FY1998 – FY2002)

>Budget : 1.28 Billion yen (including Eco-Products Exhibition)  
 Funded by the Ministry of Economy, Trade, and Industry

- >Purpose and targets
- 1) Development of LCA methodologies;  
 To learn/disseminate Practical LCI method.  
 To develop LCI method for recycling.  
 To develop LCIA method based on endpoint modeling (LIME).

2) LCI data collection by industrial associations.  
 Transparent and reliable LCI data of around 250 industrial products were collected voluntarily by 22 industrial associations of the committee and 34 industrial associations joined in the project.

System boundary: "Gate to Gate".

Inventory: 14 flows  
 (air) CO<sub>2</sub>, CH<sub>4</sub>, HFC, PFC, N<sub>2</sub>O, SF<sub>6</sub>, NO<sub>x</sub>, SO<sub>x</sub>, dust  
 (water) BOD, COD, total P, total N, SS

3) A network system to show above results.

# Organization of the LCA project

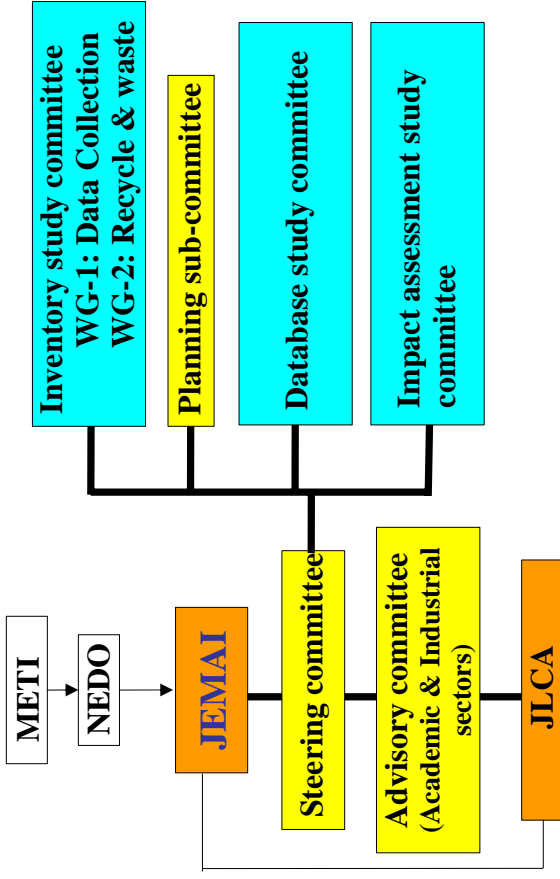

# Constructing procedure of inventory database

F.YEAR	INVENTORY COMMITTEE		DATABASE COMMITTEE
	WG-1	Task-force G	
'98	1. Basic plan of data gathering 2. Data format J-3 3. Arrangement of data-items for each industry association	1. LCI data gathering manual 2. Instructing caravan to assoc. 3. Gathering trial	1. Basic plan of database system
'99	4. Data gathering by each industry assoc. 5. Data check and Case study	1. LCI data gathering manual 2. Instructing caravan to assoc. 3. Gathering trial	2. Data input software 3. Data input manual
'00			3. Data supplying server
'01~'02			4. Complete the database system 5. Total system trial

Open to public

# Industrial Associations in the project (Committee members)

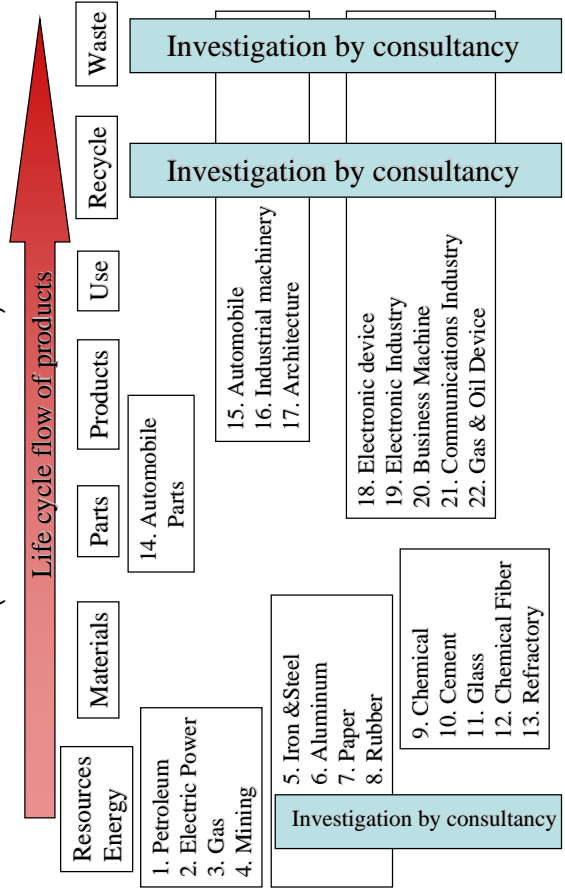

# Members of inventory data collecting

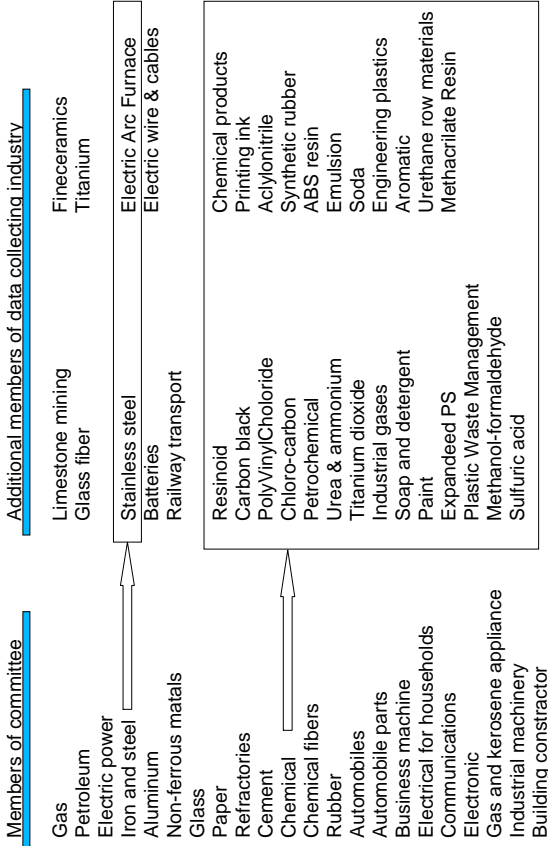

# Examples of inventory items collected by industrial associations

INDUSTRIAL ASSOCIATION	COLLECTED INVENTORITEMS	INDUSTRIAL ASSOCIATION	COLLECTED INVENTORY ITEMS
Petroleum Association of Japan	Crude oil, Bunker A, Bunker C, diesel oil, coal oil, car gasoline, naphtha, and asphalt	Japan Refractory Association	Burnt fire-proof brick, unburned fire-proof brick, refractory product, and cast able refractory
The Federation of Electric Power Companies of Japan	Electric power (domestic average, power supply specific, and for daytime or for nighttime)	Japan Auto Parts Industries Association	44 automobile parts
The Japan Gas Association	City gas and LNG	Japan Automobile Manufacturers Association, Inc.	1500cc sedan car, standard driving
The Japan Iron and Steel Federation	Shaped steel, thick plate, reinforcing steel, steel pipe, cold-rolled steel, hot-rolled steel, cold-rolled steel, tin free steel, tin plate, wire rod, special steel, stainless steel, gas pipe (seamless), welded pipe, steel and iron products for building, and cable	Japanese Association of Gas and Petroleum Appliances	SK ovens, SK stoves, gas water heaters, water heaters, table-top gas heaters, table-top stoves, hot-water dispensers, oil water heaters, bath tubs with oil water heaters, oil fan heaters, hot-water oil burners, open oil heaters, vent-system oil heaters, and semi-open oil heaters
Japan Aluminum Association	Aluminum extrusion; pipe product; aluminum extrusion; shaped product; aluminum product	Building Contractors Society	Building (office building of reinforced concrete)
Japan Mining Industry Association	Copper, lead, and zinc	The Japan Electrical Manufacturers' Association	Electric refrigerators
Japan Paper Association	Paper and paper board	Electronic Industries Association of Japan	Color televisions, cathode ray tubes, printed circuits, LCD devices, passive components, connectors, semiconductors, and converted parts
The Japan Rubber Manufacturers Association	Tires for passenger cars, tires for trucks and buses, and tires for motorcycles	Japanese Electronic Industry Development Association	Notebook PC and desktop PC
Japan Chemical Industry Association	Low-density polyethylene, high-density polyethylene, polypropylene, polystyrene, polyvinylchloride, polyethylene phthalate, and expanded polystyrene	Japan Business Machine and Information System Industries Association	Copy machines
Japan Cement Association	Portland cement, blast furnace cement, fly ash cement, clay, silica, and lime stone	Communications and Information Industries Association of Japan	Mobile phones
Flat Glass Manufacturers Association of Japan	Glass sheet (including laminated safety glass for automobiles)	The Japan Society of Industrial Machinery Manufacturers	Pumps (typical model) and fans
Japan Chemical Fibers Association	Continuous polyester fiber, and tire cord (nylon and polyester)		

# Example: Data classification and update on paper industry

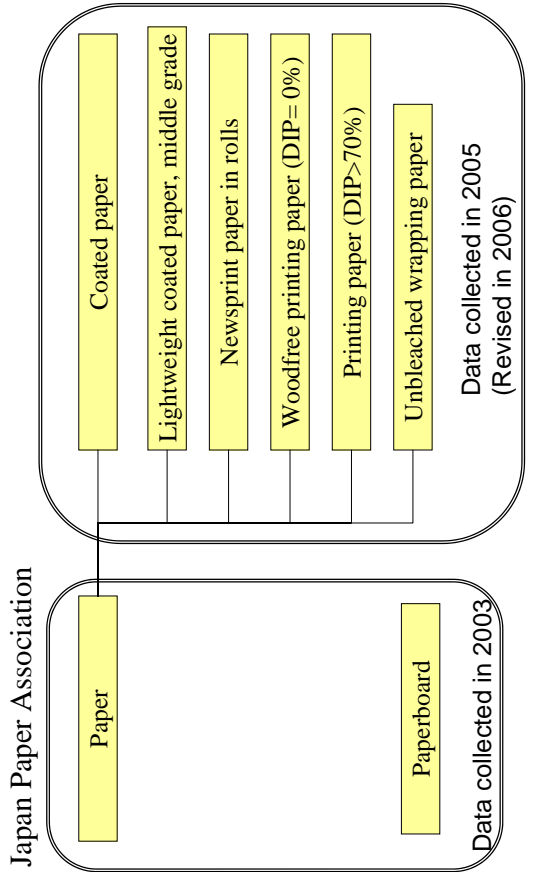

# Advantage of data collection in industrial association

- Uniformed Data supply contribute
  - To build up data-handling method based on the product characteristics.
  - To reduce work on individual data exchange.
  - To keep secrecy on manufacturing process.
- Acquisition of basic technique on LCA data construction.
- Disclosure of environmental data as corporate social responsibility (CSR)

### LIME (Life-cycle Impact assessment Method based on Endpoint modeling)

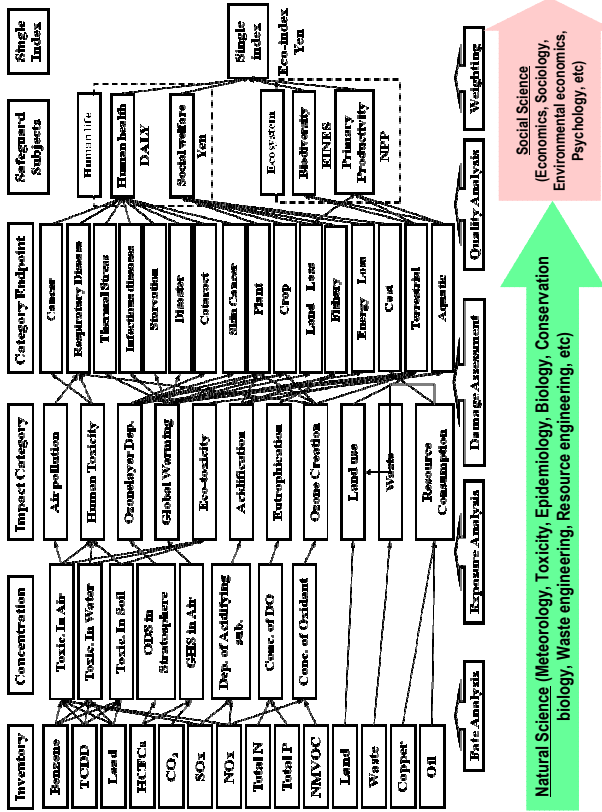

### LCA Project Phase II. (FY2003 – FY2005)

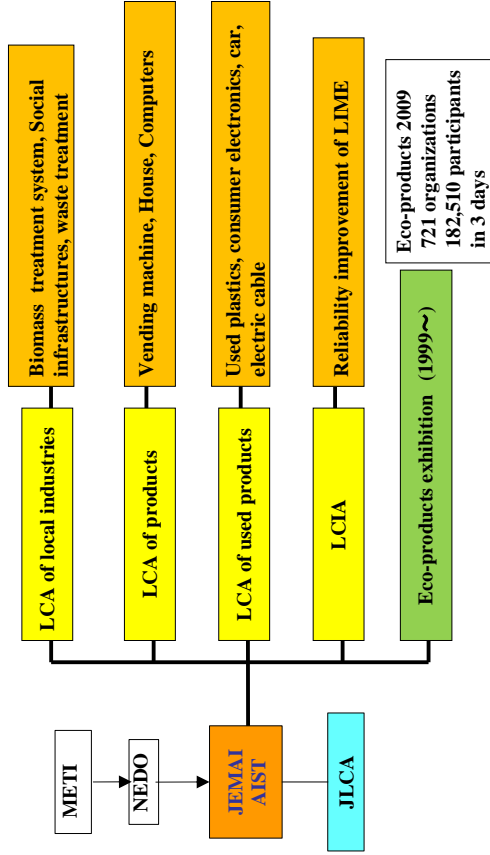

AIST: National Institute of Advanced Industrial Science and Technology  
 Copyright (C) 2010 JEMAI All Rights Reserved

## Contents

1. LCA national project in Japan
2. Life Cycle Assessment Society of Japan
3. Eco-Design Promotion Project for small and medium-sized enterprises
4. Development of LCA database and software
5. Development of CFP database

## Life Cycle Assessment Society of Japan



**President**  
 Prof. Ryoichi Yamamoto,  
 The University of Tokyo

**Secretariat**  
 JEMAI

**Establishment**  
 In 1995

**Members**  
 University research organizations 51  
 Industry associations 43  
 Other societies 3  
 Businesses 197  
 Individuals 68

**Database user: approx. 1000 in total**

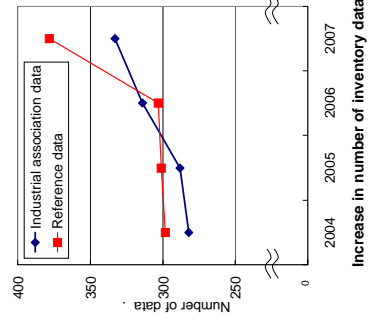

Increase in number of inventory data

At present  
 Industrial association data : 351  
 Reference data : 413

## Activities of JLCA (1)

1. LCA Database Management
  - ✦ Maintenance of inventory data provided by 54 industrial bodies
    - Industrial association provided data : about 350
    - Investigated data : about 400
  - ✦ Update inventory data
    - Installation of voluntary data provided by industrial associations
    - Collect new reference data from literature, statistics, etc.
  - ✦ compiling literatures related on LCA (about 1200)
2. JLCA Award
  - ✦ Commending organizations and people who achieved outstanding performance.
3. R&D
  - ✦ Promotion of new ideas on LCA application
  - ✦ Support with investigations of common subjects on LCA

Copyright (C) 2010 JEMAI All Rights Reserved

17

A4-46

## Activities of JLCA (2)

4. Information service
  - ✦ Sending information Periodically about LCA by e-mail
  - ✦ Holding of seminars on LCA
  - ✦ Introduction of LCA activities of business by News Letter (Japanese and English)



JLCA News Letters (English)  
<http://www.jemai.or.jp/english/lca/>

Copyright (C) 2010 JEMAI All Rights Reserved

18

## Contents

1. LCA national project in Japan
2. Life Cycle Assessment Society of Japan
3. Eco-Design Promotion Project for small and medium-sized enterprises
4. Development of LCA database and software
5. Development of CFP database

Copyright (C) 2010 JEMAI All Rights Reserved

19

## Background of the project

- SMEs account for 52% of sales and 99% of companies in Japanese manufacturing industry.
- SMEs feels difficult to implement Eco-design tools
  - 1) Most of them are standing at the middle position of the products supply chains. They have small flexibility of design and production procedures.
  - 2) Lack of information on the upper and the lower stages of the product supply chains.
  - 3) Lack of capacity to install new tools due to shortages of staff and budget for research and development.



Since FY2006, METI has implemented the project to diffuse Eco-Design tools, i.e. LCA and QFDE, to industry. (Green Performance (GP) project)

Copyright (C) 2010 JEMAI All Rights Reserved

20

## Framework and Measures

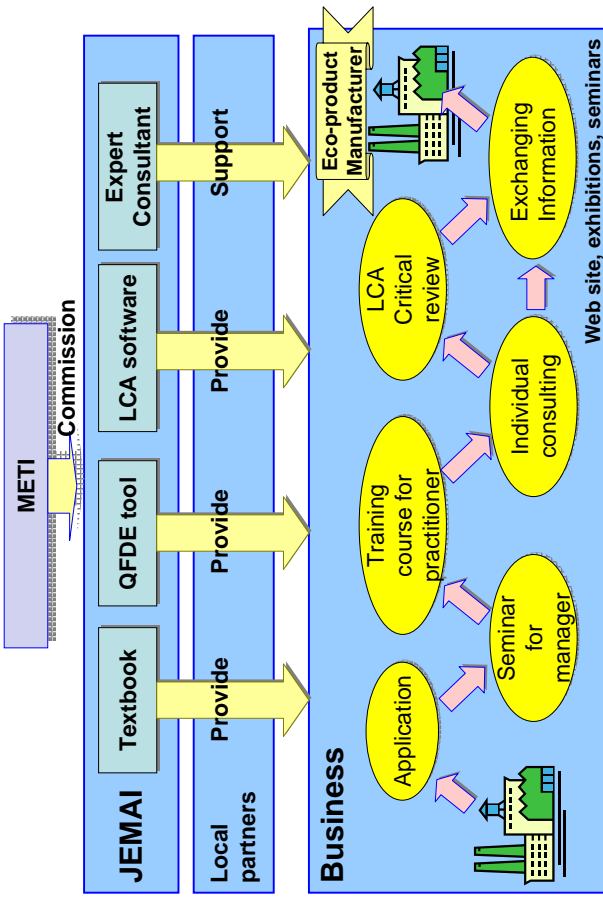

Copyright (C) 2010 JEMAI. All Rights Reserved

## Local partners of the project (FY2008)

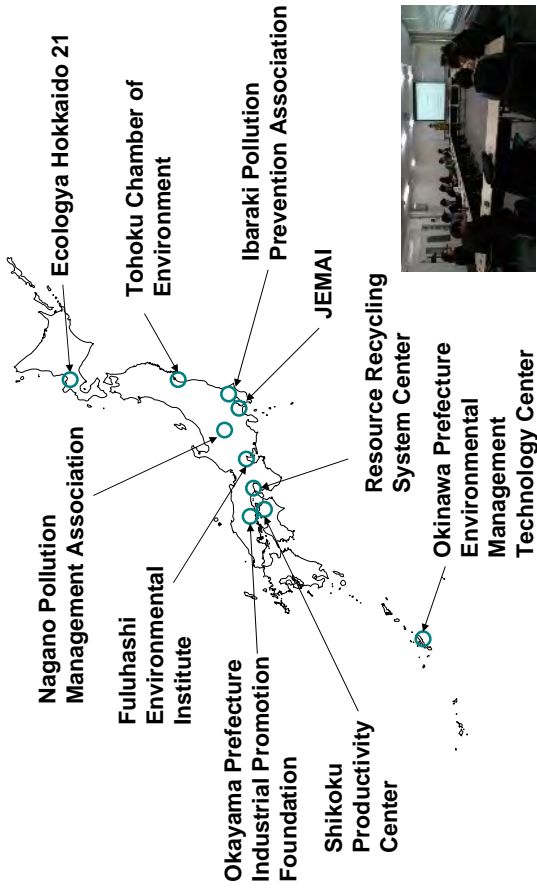

Copyright (C) 2010 JEMAI. All Rights Reserved

## Eco-Design Tools for SMEs

### (1) LCA software "Simple-LCA"

- Developed by National Institute of Advanced Industrial Science and Technology (AIST) and JEMAI.
- Easy to understand, operate and implement LCA.
- Free of charge.
- Originated from "JEMAI-LCA Pro".

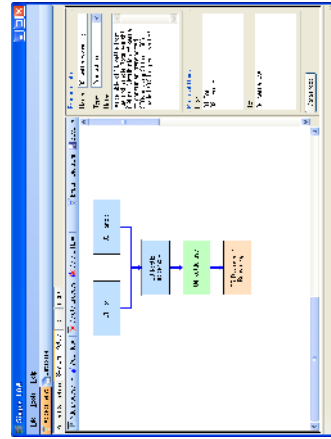

### (2) QFDE tools

- Quality Function Deployment for Environment (QFDE) is a tool that is developed to support designers at early stages of DfE for assembled products by modifying QFD.
- MS-Excel based simple software. (Free of charge)

Copyright (C) 2010 JEMAI. All Rights Reserved

## Example – Product design process

### Sirocco fan (Topre Gifu)

- Sirocco fan becomes popular for the equipment of in-house ventilation system.
- CO<sub>2</sub> emission through the life cycle is dominated by the usage stage.
- Redesign of the shape of blade to reduce the power consumption in the usage stage is effective to improve the environmental performance.

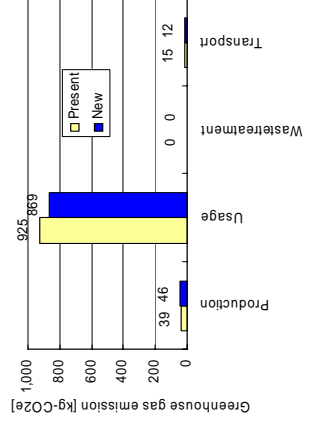
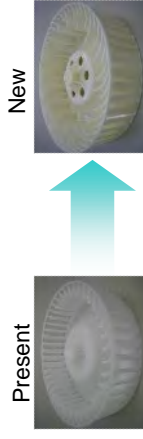

LCA Result of Sirocco fan on global warming

Copyright (C) 2010 JEMAI. All Rights Reserved

## Example – Production process

### Casting products (Matsubara)

- This company applied LCA to improve its production line because the detailed product design is strictly specified by its customer.
- The dominant factor was the cupola furnace and the pig iron production.
- The company found that the improvement of process yield and reducing the feed amount of pig iron are effective.

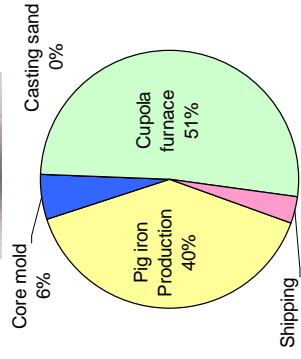
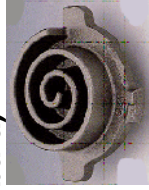

Contribution analysis of casting product on global warming

## Contents

1. LCA national project in Japan
2. Life Cycle Assessment Society of Japan
3. Eco-Design Promotion Project for small and medium-sized enterprises
4. Development of LCA database and software
5. Development of CFP database

## Results of the project

- LCA has been diffused to more about 150 SMEs from FY2006 to FY2008.
- Eco-design tools (QFDE tool and Simple-LCA) can be useful for their companies to reduce environmental impact by implementing the right tools in right timing with practical case studies.
- Moreover, resources for LCA consultation and know-how have been accumulated.

## Current status of LCI database in Japan

### Bottom up

- JLCA-database
- JEMAI-LCA Pro Standard database
  - Basic material production processes (400)
- JEMAI-LCA Pro Option database
  - Chemicals, Steels, etc. (1,300)
    - Additionally, in-house power generation and emission treatment processes (500)
- IDEA database

### Input-Output table analysis

- 3EID (National Institute for Environmental Studies): (400)
  - [http://www.cger.nies.go.jp/publications/report/d031/eng/index\\_e.htm](http://www.cger.nies.go.jp/publications/report/d031/eng/index_e.htm)
    - Approx. 400 activities data in monetary value in Japan
    - Free of charge
- Easy-LCA (Toshiba) : (3700)

## JEMAI-LCA Pro

- Developed by AIST and JEMAI.
- Released since 2000.
- The largest share in Japan (over 1000 copies are sold).
- English version has been released since October, 2007.
- Standard and option database include close to 1000 process data.

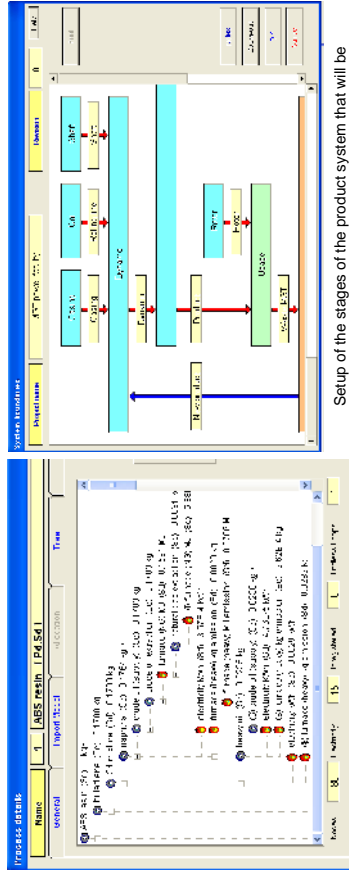

Setup of the stages of the product system that will be included in the assessment, including stage locations and transportation of products between stages.

Input and Output of each process are controlled with process tree method and calculated up to the mining of resources.

Copyright (C) 2010 JEMAI. All Rights Reserved

29

## Development of New Inventory Database Inventory Database for Environmental Analysis (IDEA)

- Developed by JEMAI and AIST
- Integration of Japanese LCI database
- Compile Japanese databases to the IDEA in uniformed method and data format.

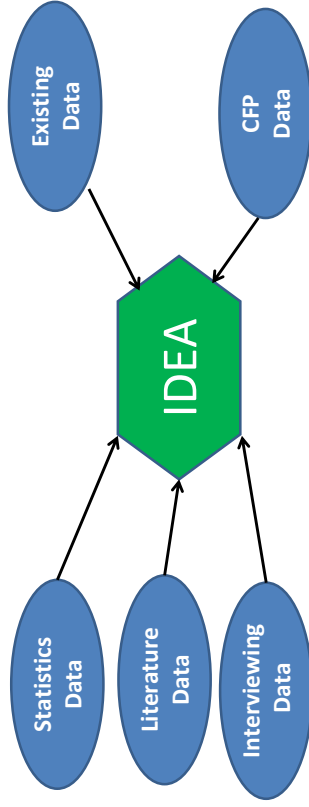

Copyright (C) 2010 JEMAI. All Rights Reserved

30

## Outlines of IDEA

- Number of datasets: >3000
- Type: “cradle to gate” and “gate to gate”, all process tree are available
- Data source: statistics, modeling, research paper
  - (1) Statistics (Energy consumption statistics, Dynamic statistics of each industry, I-O table, etc.)
  - (2) Process analysis (Interviewing and surveying).
  - (3) Literatures
  - (4) Existing data
- Impact category: global warming, acidification, solid waste emission, recourse consumption
- Review: internal review
- Ownership: AIST/JEMAI
- Limitation: available only in the LCA system “MILCA”

Copyright (C) 2010 JEMAI. All Rights Reserved

31

## Concept and schedule of IDEA

### Concept

- Comprehensiveness: most products data will be estimated from statistics and theoretical figure.
- Representativeness: collecting mainly Japanese processes
- Completeness: estimating all targeted elementary flow
- Transparency: unit process (gate to gate) data is collected and disclosed
- User friendliness: each process tree is constructed
- Reliability: data reliability is evaluated in each process
- Integration of Japanese LCI database in uniformed method and data format. (JEMAI-LCA Pro, EcoLeaf and Other data)

### Schedule

- 2008 Launch the project
- 2010 Nov. Open to the public in Japanese (2011 in English)

Copyright (C) 2010 JEMAI. All Rights Reserved

32



## Number of data in the product category

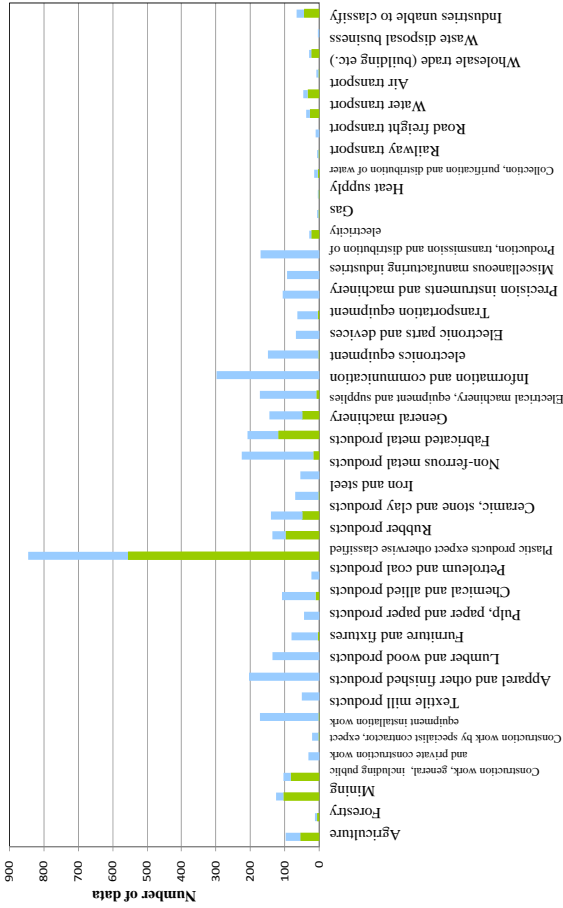

Copyright (C) 2010 JEMAI All Rights Reserved

## High transparency: Visualization of process tree



Copyright (C) 2010 JEMAI All Rights Reserved

## New LCA software "MiLCA"



- Basic functions**
- Process data management
  - Life cycle modeling
  - Inventory analysis
  - Impact assessment (characterization, weighting: LIME2)
  - Reporting assistance
  - Stand-alone performing of LCA
- New functions**
- Data sharing function: process and case study data
    - Data registration to public server, DB sharing using internal server
  - Intermediate process confidentiality assistance
    - Abstraction function of intermediate product, Process merge function
  - Improved operability

Copyright (C) 2010 JEMAI All Rights Reserved

## Contents

1. LCA national project in Japan
2. Life Cycle Assessment Society of Japan
3. Eco-Design Promotion Project for small and medium-sized enterprises
4. Development of LCA database and software
5. Development of CFP database

Copyright (C) 2010 JEMAI All Rights Reserved

## Carbon footprint database (ver.1)

for METI pilot program

- Release: Aug. 2009
- Number of data: 224
- Type: “cradle to gate” and “gate to gate”, but process tree is not available

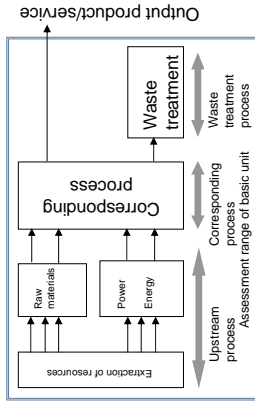

Image of assessment range

Category	Sub-category	Qty
Energy	—	14
	Wood/paper products	2
	Organic	25
Manufacturing	Inorganic	19
	Fuel, etc.	11
	Plastic	23
	Ceramic/soil and stone products	3
Transport	Iron/steel products	33
	Nonferrous metal	24
	Power usage	3
Processing	—	64
	—	3
Total		224

Copyright (C) 2010 JEMAI All Rights Reserved

37

# Thank you for your attention

Yasushi SHIRAISHI

E-mail: [shiraishi@jemai.or.jp](mailto:shiraishi@jemai.or.jp)

Japan Environment Management Association  
for Industry (JEMAI)

<http://www.jemai.or.jp/english/lca/>



Copyright (C) 2010 JEMAI All Rights Reserved

39

## Carbon footprint database (ver.2)

for METI pilot program

- Release: Sep. 2010
- Number of data: 842 (>1000 in Feb. 2011)
- Type: “cradle to gate” (process tree is not available)
- Data source: statistics, modeling and industry association
- Impact category: global warming
- Review: CFP Emission Factor Review committee reviewed with the standard of the national pilot program.
- Accessibility: open
  - <http://www.cfp-japan.jp/calculate/verify/data.html>
- Ownership: METI
- Limitation: available only for CFP pilot program in Japan

Copyright (C) 2010 JEMAI All Rights Reserved

38

1

2. As you know, by the middle of this century developed countries need to reduce their greenhouse gas emissions by more than 80 percent. As the first step toward this goal, three years ago, we set a reduction target of 25% below 2000 levels by 2020. To achieve this target, we have introduced the world's first urban cap-and-trade scheme for the Tokyo metropolitan area along with a range of other innovative programs.

3. I would like to explain in my presentation that, given clear guidelines in the form of a **bold CO2 reduction target and powerful measures**, private companies will respond with **large investments in energy-efficient technologies and renewable energy**, that enables the transition to a low-carbon city.

I would like to demonstrate this by outlining our programs and their effects on urban development and corporate activity in Tokyo. Our experience shows that sub-national governments can play a critical role in preventing climate change.

4. Before outlining the steps we have taken, let me give you a little data on Tokyo's population and economy. You all know that Tokyo is one of the largest cities in the world, but a few figures will show just how large it actually is.

Tokyo has 13 million residents in a rather small area. In 2006 the Gross Regional Product of Tokyo was 81.5 billion U.S. dollars. If Tokyo were a country, it would be the world's 15th largest economy. This would place it above Australia in terms of economic scale. In 2009 the Fortune Global 500 ranked Tokyo as having the highest concentration of headquarters of major world-class corporations, far exceeding New York City and London. Thus our climate change measures target a huge amount of economic activity.

5. Regarding our carbon footprint:

Tokyo's CO2 emissions total 65 million tons per year, with the commercial and industrial sectors accounting for half of this figure. Therefore our climate change efforts mainly target these sectors.

6. Now let's move on to the measures TMG has adopted to reduce CO2 emissions. Tokyo's key measures include:

- First, a cap-and-trade program for large facilities;
- Second, a mandatory CO2 emission reporting program for small and medium sized facilities;
- Third, a Green Building Program; and

Each of these programs is the most advanced in Japan, and measures launched by TMG are now spreading to other local governments throughout Japan. Our programs have also had a major influence on the national government.

7. First of all, I would like to explain our most important measure, namely our cap-and-trade program, which we call Tokyo ETS.

8. Since the European Union started its ETS in 2005, many countries and regions have been working toward launching such schemes, but the Japanese government has not yet determined a concrete timetable for cap-and-trade.

By contrast, in April this year TMG launched the first cap-and-trade program in Japan. Our program is the world's third mandatory reduction system, targeting industrial sector, following EU-ETS and RGGI in the U.S.

9. We decided to introduce a cap-and-trade program based on our experiences with our prior program. Eight years ago, in 2002, we introduced a program requiring large facilities to report and publicize CO2 emissions. Even though energy-saving measures need initial investment, companies benefit from reduced charges for lighting and heating. However, in operating this prior program, it became clear that most companies would only invest capital that can be recovered within a few years. The reduction targets of the companies in the program were just 2 percent in average. The voluntary program did not work. Without mandatory reductions, investment in energy conservation would not grow.

10. Based on this experience, in June 2007 we announced our plan to introduce a cap-and-trade program. By making emission cuts mandatory, our intention was to ensure that all facilities had to bear the cost of investment in emission reduction. We have believed that a mandatory reduction system would create a fair environment for investment in energy conservation. We wanted to avoid a

situation where only companies sensitive to environmental problems would pay reduction costs, thereby suffering competitive disadvantage.

1 1 Over the year following the announcement of our plans, we held meetings with stakeholders including the Japan Business Federation and other business groups and corporations, listening to a variety of opinions as we built the system. Initially all of the business groups and corporations were strongly opposed to the plan, and the stakeholder meetings featured extremely lively debate. Finally, however, the Tokyo Chamber of Commerce and Industry, which represents business interests in Tokyo, issued a statement of support for the introduction of the cap and trade. We also gained the understanding of many other corporations and business groups, and in June 2008 the Tokyo Metropolitan Assembly unanimously decided to introduce Japan's first cap-and-trade program.

Other important climate change programs besides cap and trade program went through the same process of stakeholder's meeting discussion and approval of the assembly

1 2 Now let me provide details about the Tokyo ETS.

One unique feature of this program is its coverage. This program covers not only large factories but also office buildings, commercial facilities, and public buildings. This is based on our firm belief that sweeping CO2 reductions require targeting not only major factories and power plants, but also cement-site facilities consuming electricity and gas. In this sense Tokyo ETS is the world's first urban cap-and-trade program, tailored to a city that consumes large amounts of energy.

The Tokyo ETS scheme covers facilities consuming the energy equivalent of 15 hundred kiloliters or more of crude oil, as electricity or gas per year. Approximately 14 hundred facilities fall within the scope of the cap. Their emissions account for 40 percent of all CO2 emissions from the commercial and industrial sector. Of these 14 hundred facilities, 11 hundred are offices or other commercial facilities and the remaining 300 are factories, supply and processing facilities. Almost all of the most prominent high-rise buildings in central Tokyo are covered by the scheme, which also encompasses central government buildings including the Prime Minister's Office and Parliament.

1 3 For a cap-and-trade program to be worthwhile it must include a strict cap. We set five-year compliance periods for our caps. For the first period, from 2010 to 2014, we set the cap at a 6 percent reduction below base-year emissions.

The cap for the second period, from 2015 to 2019, has not yet been finalized, but we have announced that it will be around 17 percent. We made this announcement in response to calls from companies wanting early notice of mid-range reduction goals in order to justify long-term investments in energy efficiency. Compared to the EU-ETS and the RGGI in the US, this is quite a severe cap.

1 4 Based on the caps I described, emissions allowances to the targeted facilities are allocated based upon historical emissions. Because we have operated the mandatory reporting system since 2002, we already have a record of individual facilities' past emissions. These data enables us to allocate allowances fairly.

Through its own reductions or emissions trading, each facility must bring its total emissions for the five-year period within the allowance. Any company that fails to carry out its reduction obligations will be publicly named and subject to penalties and surcharges.

1 5 Now, let me explain about the offsets allowed under the Tokyo Cap-and-Trade Program.

In addition to the emissions trading with other facilities under the cap, facilities may use several offset projects to meet their obligation.

Currently, three types of offsets are assumed under our program.

The first category is credits from small and medium facilities.

This will include the emission reductions taken by small and midsize facilities in Tokyo, and the buyers can buy necessary amount without limit from them.

The second category is Renewable Energy Credits.

These include solar energy (both heat and light), wind energy, geothermal energy, hydropower energy (under 1000 kilo watt), and biomass energy (which has biomass rate of 95% or above)

The third category is credits from outside Tokyo.

This will include emission reductions from only large facilities with less than 150 thousand ton base year emission, and do not include small or midsize facilities, nor large ones with more than 150 thousand ton base year emission.

The large facilities covered under the outside Tokyo offset credit will be assumed

to be covered under the Tokyo Cap-and-Trade Program, and thus only the reduction exceeding the reduction obligation would be counted as offset credits. Buyers are only allowed to buy this offset credit up to 1/3 of their base year emission.

1.6 The second measure which we have adopted to reduce CO2 emissions is a mandatory CO2 emission reporting program for small and medium sized facilities;

1.7 For companies with multiple buildings, factories, located throughout Tokyo, if the combined crude oil equivalent consumption is over 3 thousand kl per year but no single facility is over 15 hundred kl per year the headquarters of the company must submit an annual energy efficiency plan report, which is made publicly available.

This is the first mandatory reporting program for small and medium facilities in Japan. 300 companies and 30 thousand facilities are expected to be covered.

Although these facilities are not required to cap their emissions, we aim to help them understand both their energy consumption profiles and available methods.

1.8 The third measure which we have adopted to reduce CO2 emissions is TMG Green building program.

1.9 This program was first launched in 2002, and has been revised and strengthened twice and from this year applies to all buildings with floor area of 5,000 square meters or more.

This means the program will cover almost half of the total floor space built annually in Tokyo.

The aim of the program is to establish a system for evaluating buildings in the housing market for environment-friendly features, so that owners will be more encouraged to incorporate environmental aspects into building design.

Owners of buildings are required to submit plans on energy and environmental conservation and disclose their plans and rated results.

They are also required to consider introducing renewable energy technologies, in accordance with a process set by the Tokyo Metropolitan Government (TMG).

2.0 Under this program, an evaluation statement of environment-conscious measures shows some of the results of evaluation in a bar graph. So that everyone can identify the level at which their environment-conscious measures are placed at a glance. All the results are posted on TMG web site

2.1 As I mentioned Tokyo ETS began in April this year, but now I would like to briefly outline some examples of how it is already influencing urban development and the actions of companies.

2.2 First, in the urban development field we are starting to see bold, unprecedented investments in energy efficiency. Japan's leading developers are now competing to start constructing office buildings with highly advanced energy performance.

This is the headquarters of a construction company, Shimizu Corporation, now being built in central Tokyo. By introducing advanced technology including a daylighting system and radiant air conditioning, it has been designed to reduce energy consumption by 50 percent compared to conventional buildings. Several more developers are also promoting such low-carbon office projects.

2.3 Second, existing buildings are also being renovated.

This building is ranked as one of the lowest emission office buildings in our existing program. The owner of the building, Mitsui Sumitomo Marine and Fire Insurance is aiming to improve even further by starting a retrofit project including the district heating system to become the lowest-emission building in Tokyo.

Also, Mitsui Real Estate Development Corporation has introduced a retrofitting program in their tenant office buildings that aims to reduce energy consumption by around 35 percent.

2.4 The third example is the increased introduction of on-site renewable energy. In tandem with energy-saving efforts, companies have started to introduce on-site solar energy system and geothermal heat pumps to reduce CO2 emissions. Some PVs are even set in the system walls like these.

These are just a few examples of the changes happening in Tokyo. Various other initiatives are springing up, including plans to use emission reductions from small and medium-sized facilities to generate offset credits.

2.5 So far I have explained our strategies in commercial and industrial sectors, which our climate change efforts mainly target. But today I would like to mention the other climate strategies in residential sector and transportation sector though they are not my speciality.

2.6 The fourth measure which we have adopted is a program to expand solar energy use.

2.7 Back to our carbon footprint; Residential sector covers nearly one fourth, a quarter.

2.8 To promote to introduce solar energy in Tokyo, we set the target to introduce at least 1 million kW solar energy facilities in Tokyo by 2016.

To achieve this target, we started the subsidy program to provide substantial subsidy in exchange of environmental value for renewable. Along with national and other municipal governments subsidies, the payback time for the installation is drastically shorten. This large scale subsidy with the total budget 90 million \$ will surely stimulate solar energy introduction and supply.

2.9 The next strategy in residential sector is the household energy consultant program.

3.0 We started this program in March this year in cooperation with gas companies, electric utilities, and consumer cooperatives. Under this system, experts in household energy conservation who are registered with the metropolitan government, visit households and provide residents with energy-saving advice tailored to their individual circumstances, free of charge.

3.1 Let me move on to the next strategy in transportation sector, that is controlling traffic volumes.

3.2 Again back to our carbon footprint; Transportation sector covers 22% of total CO2 emissions in Tokyo.

3.3 TMG is promoting transportation demand management.

The graph on the left shows volume of CO2 emissions per person per kilometer traveled. You can see passenger vehicles emit more than trains, buses, and airplanes.

The graph on the right shows the lower the average traffic speed, the higher the volume of CO2 emissions. Especially when the average speed becomes less than 20km/h, the emissions sharply increase. City roads in Japan are congested and the mean speed of the automobiles is only 16.8km/h in the 23 wards in Tokyo.

However CO2 emissions from automobiles can be reduced by driving them smoothly.

3.4 By promoting transportation demand management, we try to shift from over dependence on passenger vehicles. For example, we are introducing park & ride, and improving of cycle roads for riders can travel safely

3.5 The next strategy for transportation is controlling vehicle emissions. The previous one is to minimize the number of vehicles. This one is to minimize the volume of emissions from one vehicle.

3.6 For example, TMG enhances low fuel consumption vehicles. We call upon national government and car manufacturers to strengthen measures in order to reach fuel efficiency standard ahead of schedule, and the TMG will encourage residents of Tokyo and companies choosing vehicles with higher environmental performance preferentially. And TMG will be positively valuing electric vehicles and plug-in-hybrid as well

As alternative fuels of fossil fuels, biomass fuels, (including Bio Diesel Fuel, and Bio Ethanol) contribute to greenhouse gas reductions. TMG will encourage manufacturers and marketers of vehicle fuels to promote widespread use of biomass fuels

3.7 My presentation today has outlined Tokyo's strategy to reduce CO2 emissions such as cap-and-trade program and some of the changes they are bringing about. As I said at the beginning, setting bold CO2 reduction targets and introducing mandatory measures to assure they are achieved encourages private-sector investment in energy-saving technologies and renewable energy.

enabling the creation of a low-carbon city. I hope my outline of our work in Tokyo has helped you to understand our approach.

3 8 We are now encouraging the spread of these Tokyo initiatives throughout Japan. As a first step, we are working to expand the Tokyo ETS by adding additional prefectures, which would then cover the entire greater Tokyo region. In November last year, governors and mayors from the greater Tokyo area examined the possibility of regional-level emissions trading.

According to a survey released last year by the London-based consultancy PricewaterhouseCoopers, in 2006 the Greater Tokyo regional economy was worth 1.5 trillion U.S. dollars, making it the world's biggest metropolitan economy. If emissions trading system is introduced in the entire Greater Tokyo region, we are convinced that this will not only have a big impact on Japan as a whole, but also make a major contribution to advancing climate change measures worldwide.

3 9 As Japan's largest sub-national government, We, Tokyo Metropolitan Government will continue making the utmost efforts to achieve a low-carbon city. Thank you.

# Welcome to Kyoto Municipal Waste Edible Oil Fuel Production Facility



## Approaches to biodiesel fuel production project

In order to prevent global warming and to create a recycling society, Kyoto City is recovering waste edible oil discharged from households and refining it to produce environmentally friendly biodiesel fuel from the viewpoints of waste edible oil recycling, purification of automobile exhaust gas, reduction of carbon dioxide emissions, live education about environmental problems and vitalization of local communities. This biodiesel fuel is currently used by all waste collecting vehicles and some municipal buses. These approaches contribute to a reduction in carbon dioxide emissions by about 4,000 tons per year.

## Current situation of waste edible oil recovery

The raw materials for biodiesel fuel produced in this facility are waste edible oil (used tempura oil) discharged from general households as well as restaurants and cafeterias in Kyoto City. Waste edible oil is recovered monthly from households by placing polyethylene tanks in recovery points with the cooperation of the Regional Waste Reduction Promotion Committees basically established in each district or volunteers in every region in partnership with citizens. We will enhance linkages among citizens, companies, and the municipality to aim for an increase in recovery point.

## Recycling of waste edible oil to biodiesel fuel contributes to:

- **Global warming prevention thanks to reduction of fossil fuel consumption**

Application of biodiesel fuel originating from organisms eliminates carbon dioxide emissions caused by fossil fuel combustion and significantly contributes to the prevention of global warming by using the fuel as an alternative to light oil, a type of fossil fuel.

- **Environment friendly low public hazard fuel**

Biodiesel fuel is a low public hazard and one that greatly reduces black smoke contained in automobile exhaust gas and produces very little sulfur oxides that may generate acid rain.

- **Promotion of recycling society creation**

Approaches to expand the cycle of waste edible oil recovery and to recycle it as fuel in partnership with citizens, companies, and the municipality promote human exchange and vitalize local activities essential for creating a recycling society.

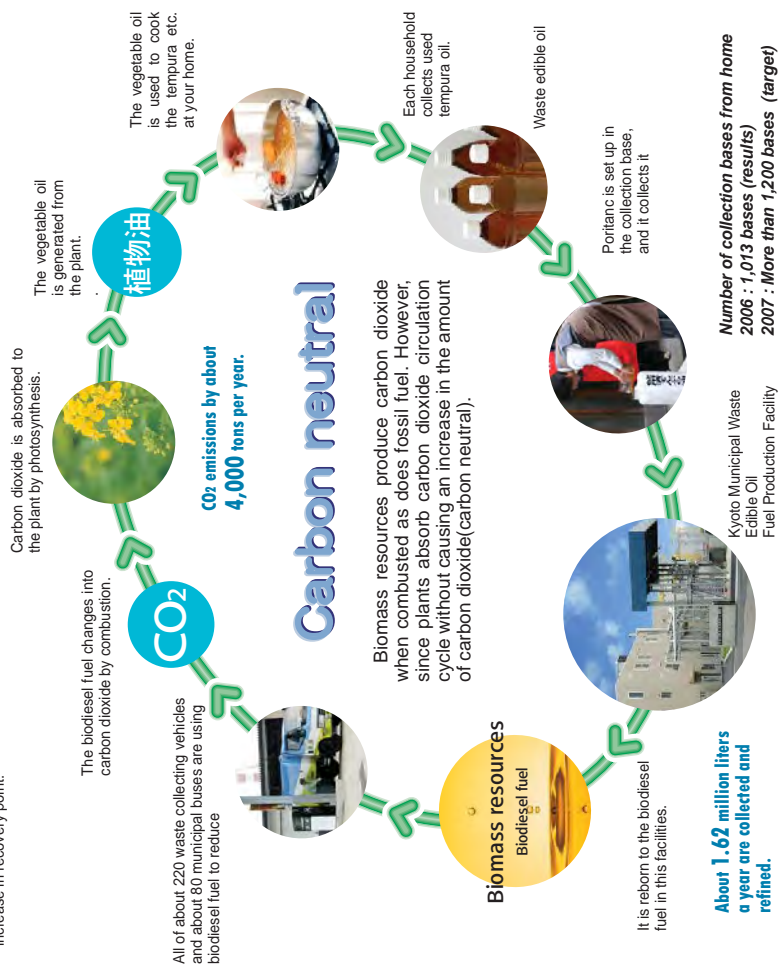

## Collected household used edible oil

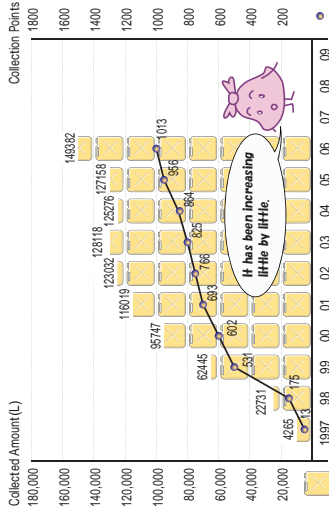

## Quality standard of biodiesel fuel

Kyoto City developed the preliminary standard (Kyoto Standard) in order to secure high quality biodiesel fuel applicable to newly commercialized vehicles based on findings obtained from actual vehicle travel tests, as well as basic information on typical standards for biodiesel fuel established in Europe and the United States. In particular, we defined the values for the pouring and clogging points affected by low temperature in winter, using the lowest temperature in Kyoto.

### Standards for biodiesel fuel

Item	Unit	Preliminary of Kyoto March 2002	EU Standard EN14214 July 2005	United States D6751 January 2002
Density (15°C)	g/ml	0.86-0.90	0.86-0.90	0.88
Dynamic viscosity(40°C)	mm <sup>2</sup> /s	3.5-5.0	3.5-5.0	1.9-4.0
Pour point	°C	-7.5 or less	-	-
Clogging point	°C	-5 or less (operation winter)	15 (to 45 (operation winter))	-
10% residual carbon	%	0.30 or less*	0.30 or less	0.50 or less (10% fuel)
Cetane number		51 or more	51 or more	47 or more
Sulfur content	ppm	10 or less	10 or less	500 or less
Flashing point	°C	100 or more	120 or more	130 or more
Moisture	ppm	500 or less	500 or less	500 or less
Monoxybenzene	%	0.8 or less	0.8 or less	-
Diglyceride	%	0.2 or less	0.2 or less	-
Triglyceride	%	0.02 or less	0.2 or less	0.02 or less
Free glycerin	%	0.02 or less	0.02 or less	0.02 or less
Total glycerin	%	0.25 or less	0.25 or less	0.24 or less
Methanol	%	0.2 or less	0.2 or less	-
Alkali metals (Na+K)	mg/kg	5 or less	5 or less	-
Acid value		0.5 or less	0.5 or less	0.8 or less
Iodine number		120 or less	120 or less	-

\* Value for reference

## Kyoto Municipal Waste Edible Oil Fuel Production Facility

Senryomatsu-cho 447, Yokooji, Fushimi-ku, Kyoto City, 612-8244  
(located in the Kyoto Municipal South Clean Center)  
TEL:075-604-5880 FAX:075-604-5884

## History of approaches to biodiesel fuel production project

July 1986: Discussion about legal compliance started with relevant agencies.

October: Long-term travel test conducted for six months using four vehicles for separately collecting waste bottles and cans.

January 1997: Influence on vehicles investigated. Exhaust gas investigated in detail (until March 1997). Since no problems regarding safety and the environment were found, activities were enhanced toward full-scale implementation.

March: Exhaust gas measurement of 6-mode performed by the Japan Automobile Transport Technology Association. It was recognized that all contents of CO, HC, NOx, etc., satisfy the restricted values.

June: One-month travel test conducted using 21 waste collecting vehicles of all Town Landscaping Offices.

August: Model tests for collecting house hold waste edible oil started. Collecting area expanded step by step.

September: Discussed the light oil inward tax with Kyoto Prefecture. It was decided that use of 100% biodiesel fuel is free of duty.

Final discussion about automobile inspection certificates implementation instructions in the road transportation vehicle law was partly amended to allow description of "Waste edible oil commonly used" in the remarks column of the automobile inspection certificate.

Oil stations installed at the sites of the West, East, and North: South Clean Center.

The fuel fully introduced to all waste collecting vehicles (about 220 cars) (annual consumption 1.3 million liters). Kyoto Conference on the Prevention of Global Warming (COP3) held in Kyoto City.



The fuel was approved as a twenty-first century January 1998: type of new energy and received the 1998 New Energy Grand Prix "Resource and Energy Minister Award" (from New Energy Foundation).

Experimental application to municipal buses started April.

Application of biodiesel (containing 20%) to about 80 municipal buses started.

An oil station installed at the site of the North-East Clean Center.

July 2001: Technical Biodiesel Fuel Production Project. Technical Study Committee established.

March 2002: Preliminary quality standard for biodiesel fuel in Kyoto City developed.

June 2002: Assistance for biodiesel fuel requested to the government.

May 2004: Kyoto Municipal Waste Edible Oil Fuel Production Facility Completed.

February 2005: The Kyoto Protocol comes into effect.

May 2006: Issue of biodiesel Handbook

September 2006: The running experiment with B100 began with the city bus. January 2007: Paris-Dakar Rally was run the whole distance with this facilities biodiesel

March 2007: fuel. (Former F1 racer, Ukyo Katayama)

The nationwide biodiesel fuel use promotion conference started.







# Realization of Low Carbon Society

- Efforts in Shiga Prefecture -



November 5, 2010

Global Warming Issues Division  
Department of Lake Biwa and the Environment  
Shiga Prefecture

# 1. General Information of Shiga Prefecture

## Geographical Location of Shiga Prefecture

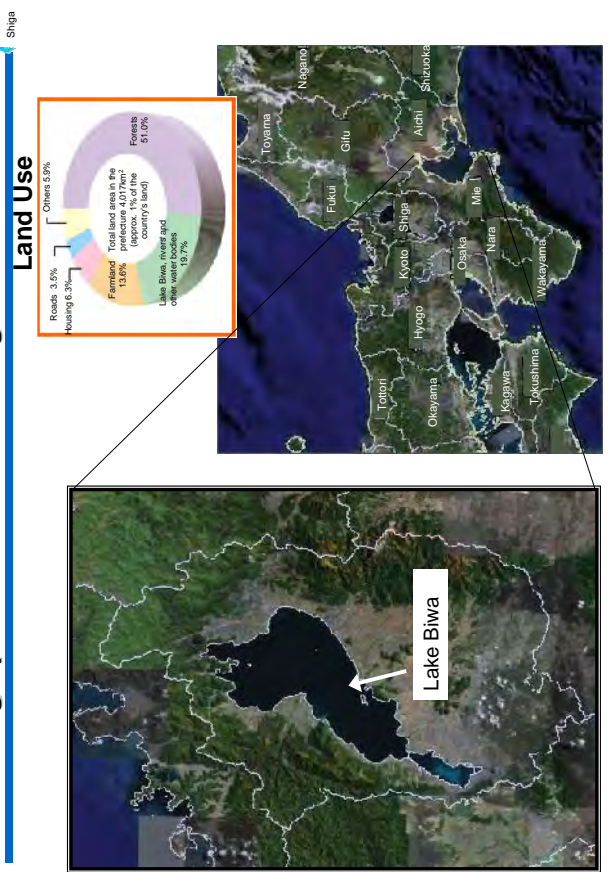

## Sceneries around Lake Biwa in Shiga

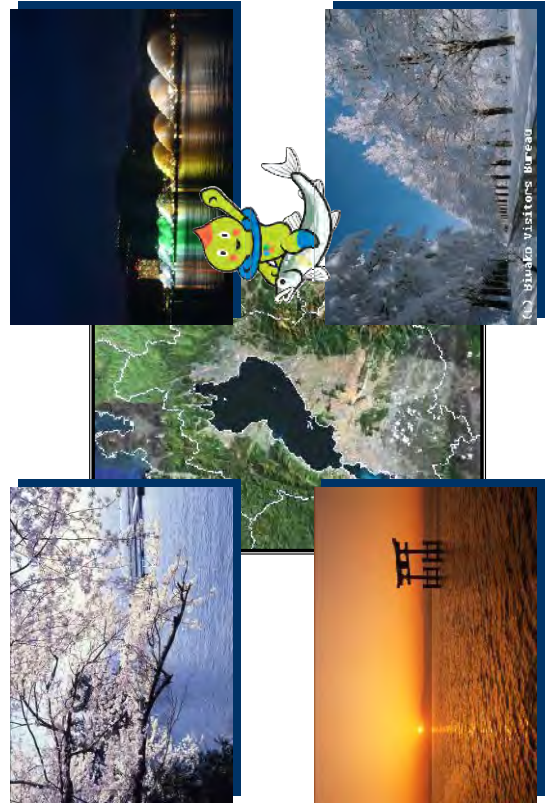

## Lake Biwa is a "Small Window" of the Earth's Environment

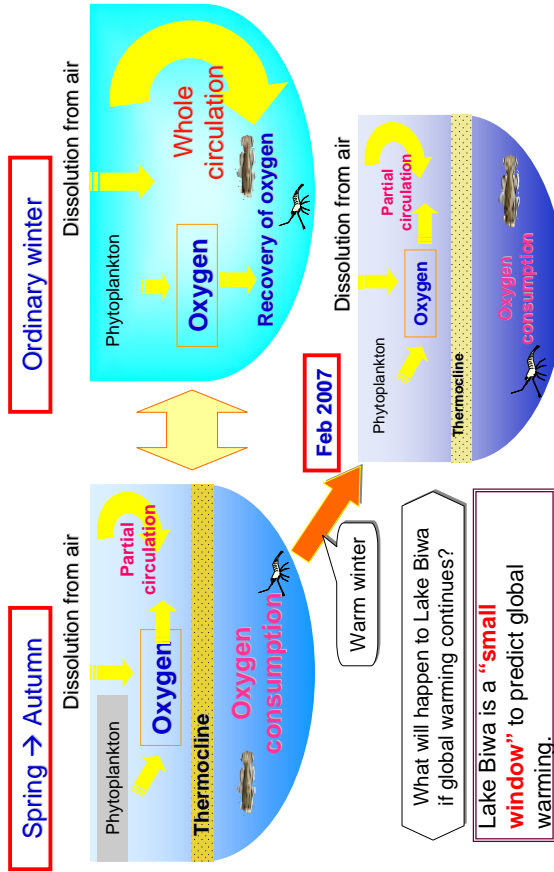

5

A4-60

## Greenhouse Gas Emission Trend in Shiga

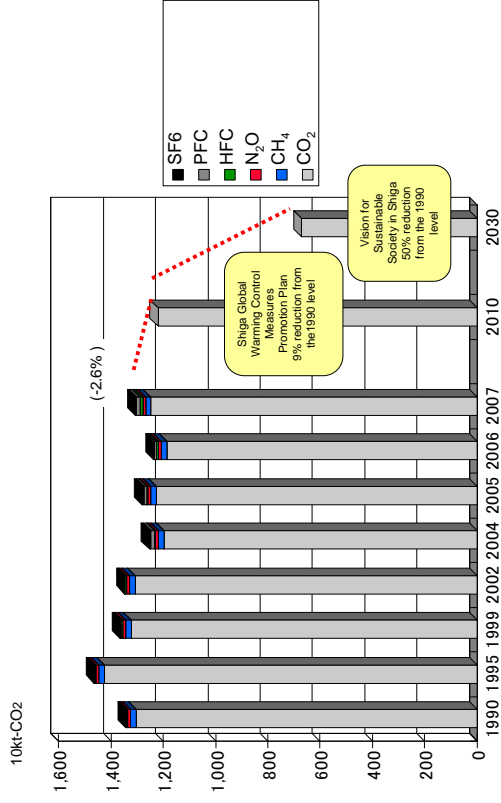

6

## 2. Target Setting in Shiga - Concretization of Low Carbon Society -

## Breakdown of CO<sub>2</sub> Emission in Shiga

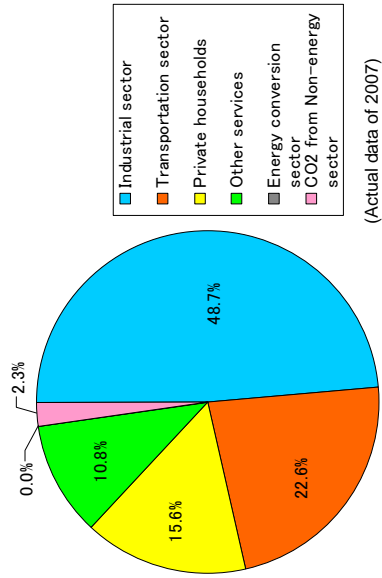

### [Characteristics]

- Industrial structure centered around secondary industries
- Dependence on automobiles
- Rapid increase of population and spread of durable goods

7

# Study for Low Carbon Society in Shiga

## Vision for Sustainable Society in Shiga

(established in March 2008)

Ideal state of the society in 2030

“Low Carbon Society” “Recycling-based Society”  
“Society Co-existing with Nature”

### 3rd Shiga Prefecture Comprehensive Environment Plan

(established in Dec 2009)

#### Realization of Low Carbon Society

GHG emission in 2030  
**50% reduction**  
(compared with 1990)

#### Long-term Goal

Environmental  
Regeneration  
of Lake Biwa

● Shiga Prefectural Ordinance for Global Warming Control Measures Promotion (tentative name)

● Creation of Roadmap for Low Carbon Society

Revision of Mother Lake 21

9

## What is “Vision for Sustainable Society in Shiga”? (2)

### Vision for Shiga in 2030

#### 1. Vision for Society and Economy in Shiga in 2030

Draw a framework for society and economy based on such indicators as population and scale of economy before creating a vision for ideal state of Shiga in 2030.

##### (1) Population and number of households

- Total population: **approx. 1,368,000**
- Number of households: **approx. 520,000** (2005: approx. 470,000)

##### (2) Size of economy – Estimation with Shiga Macro-Economic/Financial Tool

- Gross prefectural product: **increased to approx. 7,677 billion yen (up 30% from 2002)**

##### (3) Industrial Structure – Estimation through inter-industry analysis

- Share of tertiary industries: **increased to 47.6% (2000: 36.7%)**

##### (4) Lifestyle – How average people in Shiga spend their day

- Improvement of work-life balance and diffusion of work-sharing etc.
- Men: working hours decreased and housework hours increased
- Women: working hours increased and housework hours decreased

11

## What is “Vision for Sustainable Society in Shiga”? (1)

### Background and Purpose

- Environmental problems becoming increasingly serious on a global scale
- Environmental changes around Lake Biwa



To realize Sustainable Society in Shiga

### Possible countermeasures in Shiga

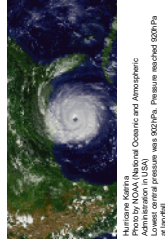

Hurricane Katrina  
Photo by NOAA National Oceanic and Atmospheric Administration  
Lowest central pressure was 902(hPa). Pressure reached 920(hPa) at landfall.



[Hurricane Katrina]  
[Increase of non-native fish species]

[March 2006]

“Vision for Sustainable Society in Shiga (draft)”  
(Working Committee, consisting of experts and division directors of the dept.)



[March 2007]

“Scenario toward Realization of Sustainable Society”

(Shiga Prefecture Sustainable Society Research Team: consisting of experts)

Secretariat: Lake Biwa Environmental Research Institute)

## “Vision for Sustainable Society in Shiga” established in March 2008

10

## Vision for Shiga in 2030

### Ideal State of Society (Vision for Sustainable Society in Shiga)

#### Target vision for Sustainable Society in Shiga

**Affluent and safe society where the environment including Lake Biwa and ecosystems in Shiga are kept healthy and the life quality of all residents in the prefecture is improved through balanced economic growth**



Nature and Climate



Community Development



Industry



Life

12

Greenhouse Gas Emission and Reduction by Sector

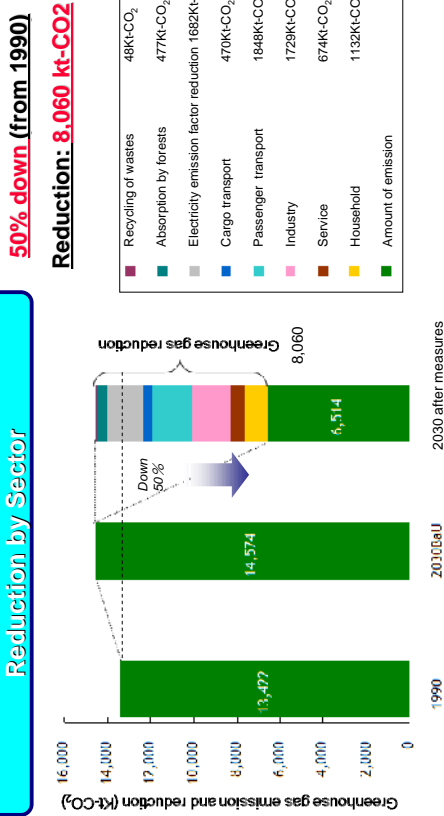

Note) BaU stands for Business as Usual, case where no additional measures are taken to reduce greenhouse gas emissions.

(Ref. Vision for Sustainable Society in Shiga)

For Realization of Low Carbon Society in Shiga (Environment Council Report in March 2010) Summary

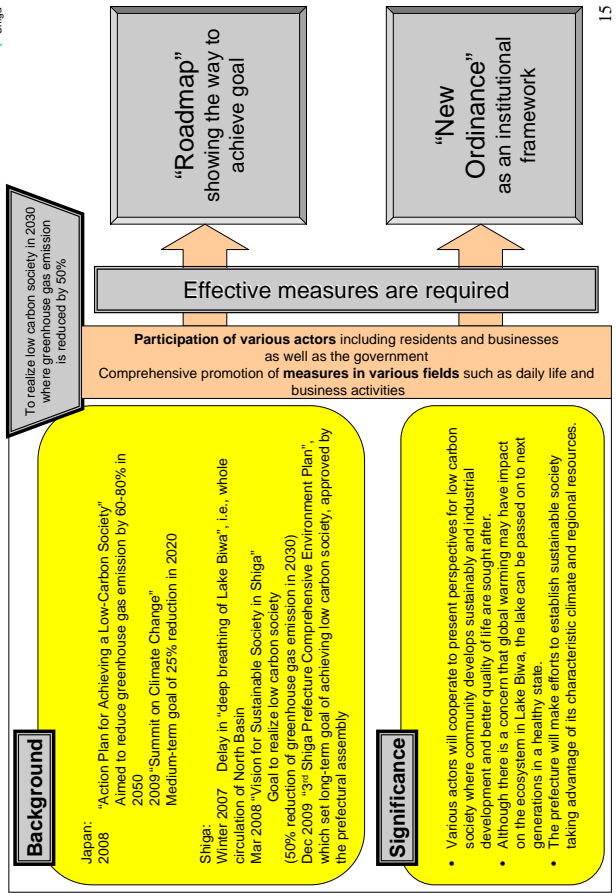

# 3. Development of Roadmap for Low Carbon Society

## Challenges in Promoting Actions for Realization of Low Carbon Society

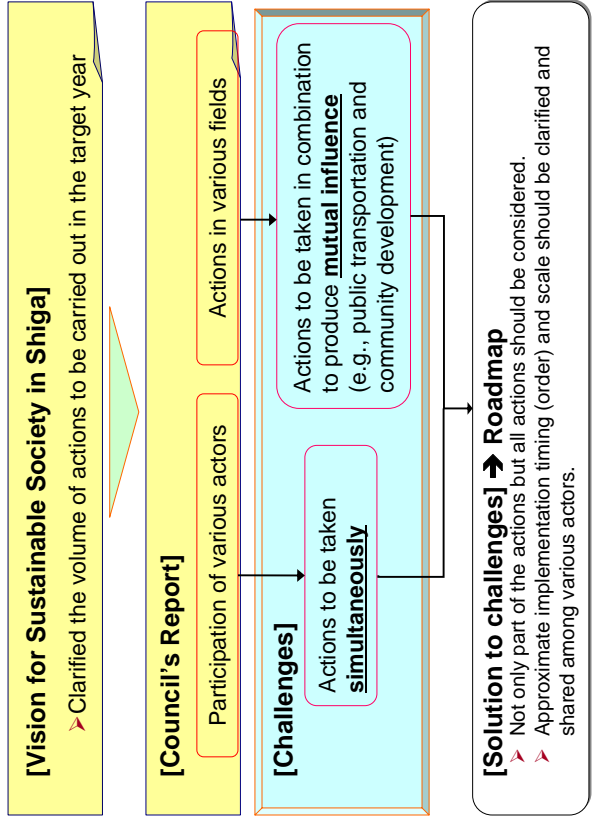

## Image of Roadmap

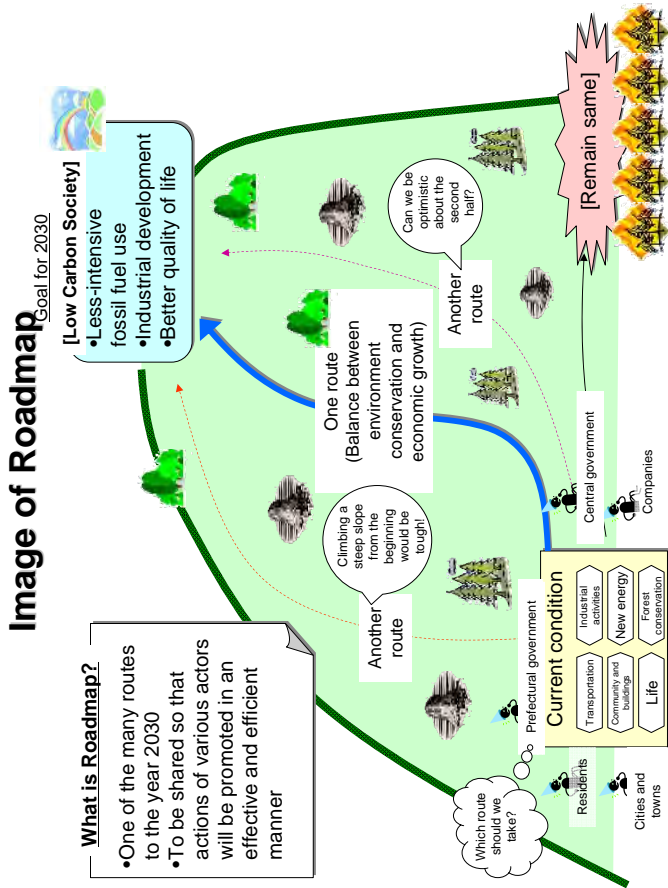

## Workflow of Roadmap Development in Shiga

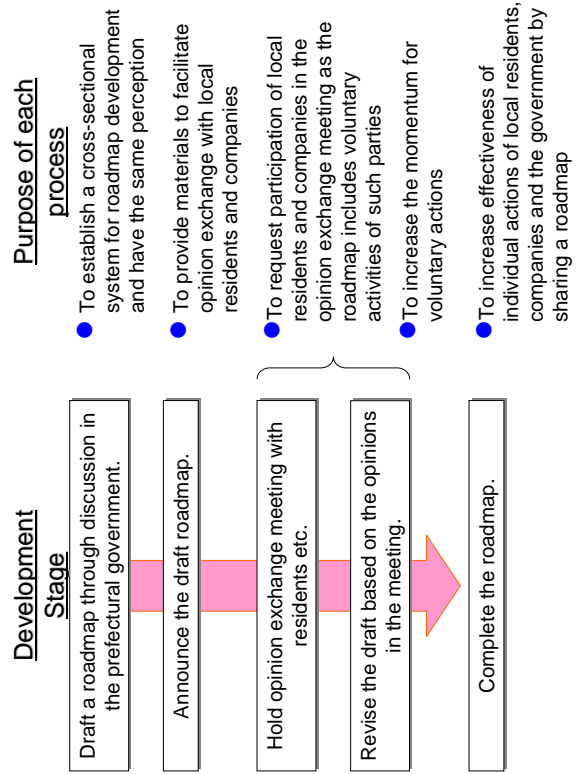

## Flowchart of Techniques for Roadmap Development

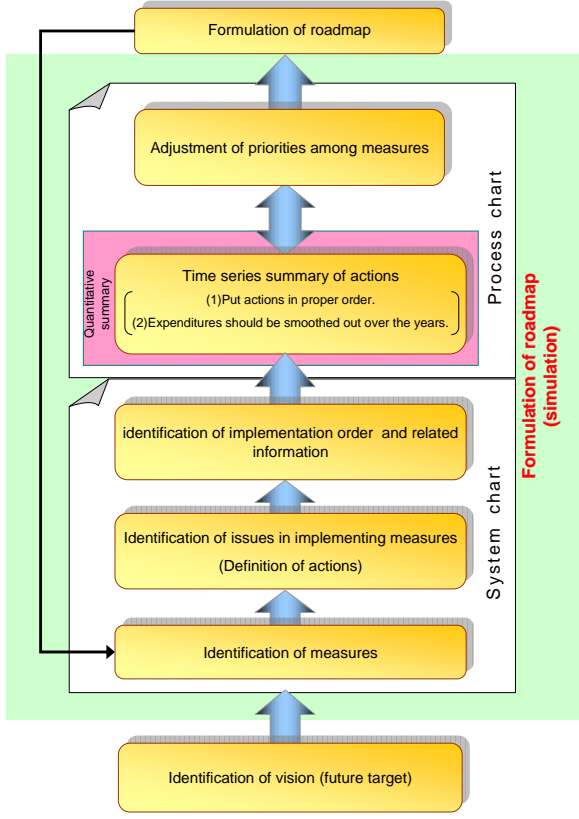

## Development of Draft Roadmap in the Prefectural Government

- Organization for Draft Development  
Global Warming Countermeasures division, a cross-sectional organization in the prefectural government led by the governor, developed a draft roadmap. Identification of concrete measures and such other works were done by a project team, a subordinate body consisting of 12 departments and 35 units.
- Details of Development  
Identification of measures and actions that will be the components of the draft roadmap. Identification of various information about measures (scale, time period and cost required for implementation).
- How to Develop Draft
  - (1) Identification of measures: Identify issues that have to be solved in order to realize the target vision and set the specified concrete actions to solve such issues as measures.
  - (2) Project scale: Define the project scale to ensure the expected reduction amount for each sector under the target vision was achieved.
  - (3) Implementation timing: Adjust the order and timing of the implementation of measures based on the simulation result and in light of each team member's knowledge.
- Rules for Roadmap Study
  - All measures that are effective in reducing greenhouse gas should be analyzed, regardless of how difficult they are to implement.
  - Although it was clear that the current budget would not be enough, the prefecture calculated expected budget deficit as a condition for implementation of the whole roadmap and passed the issue on to the discussion of environmental tax.

## Composition of Draft Roadmap (1) (System Chart)

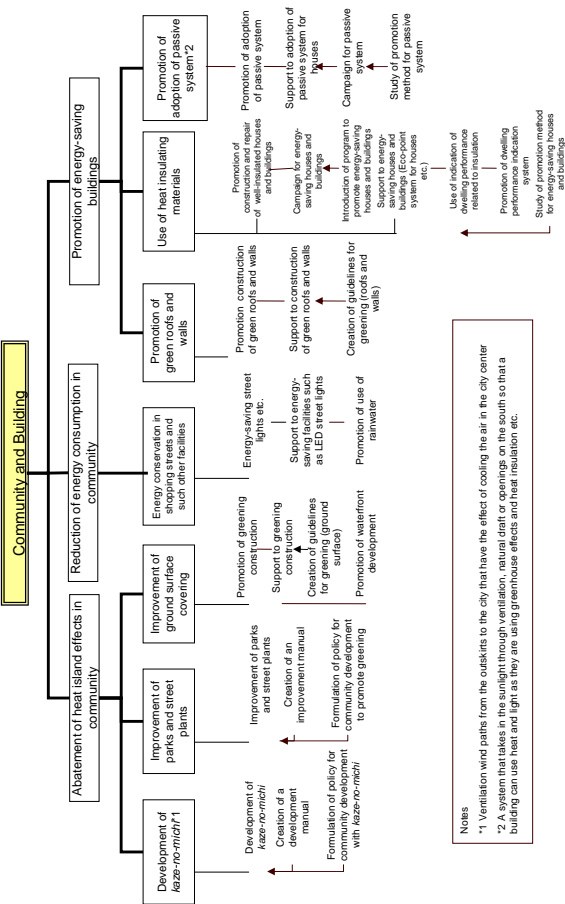

## Composition of Draft Roadmap (2) (Process Chart)

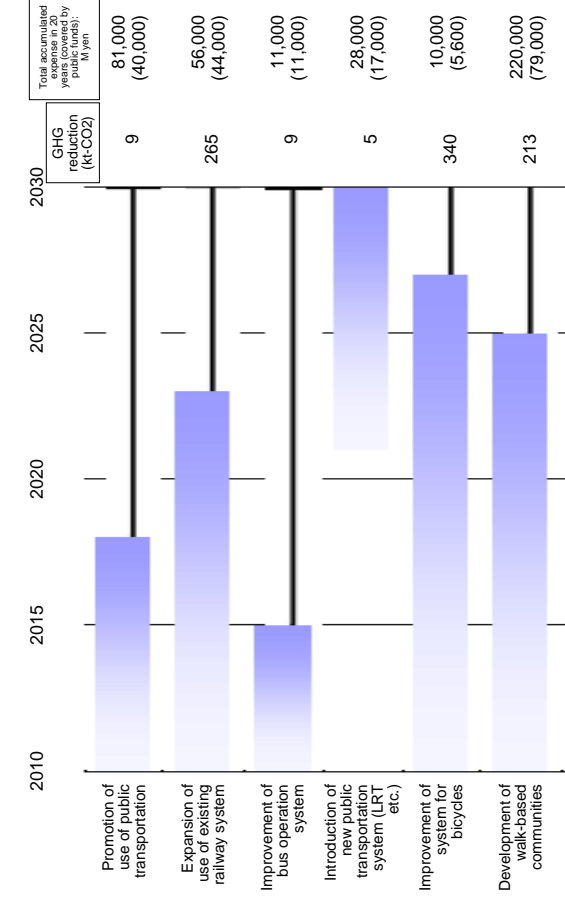

## Composition of Draft Roadmap (2) (Process Chart)

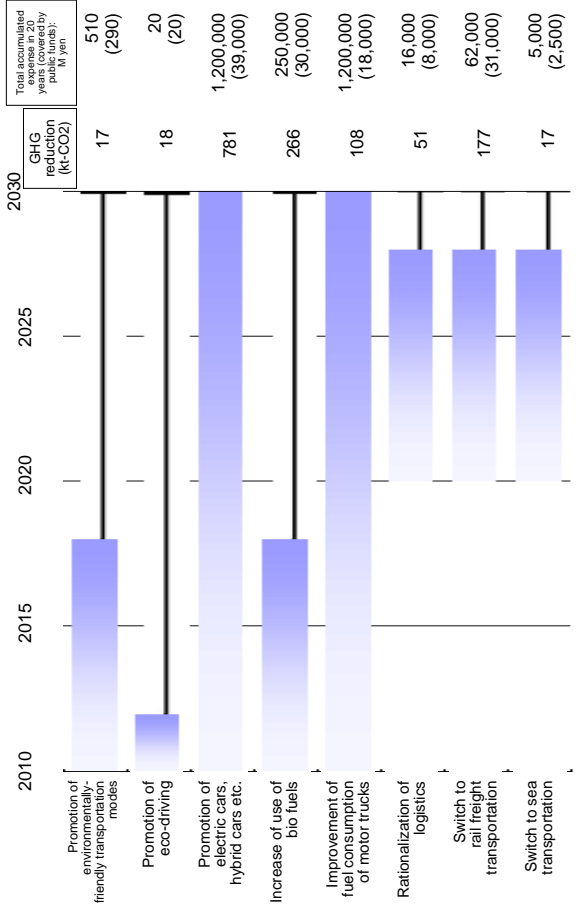

## Composition of Draft Roadmap (2) (Process Chart)

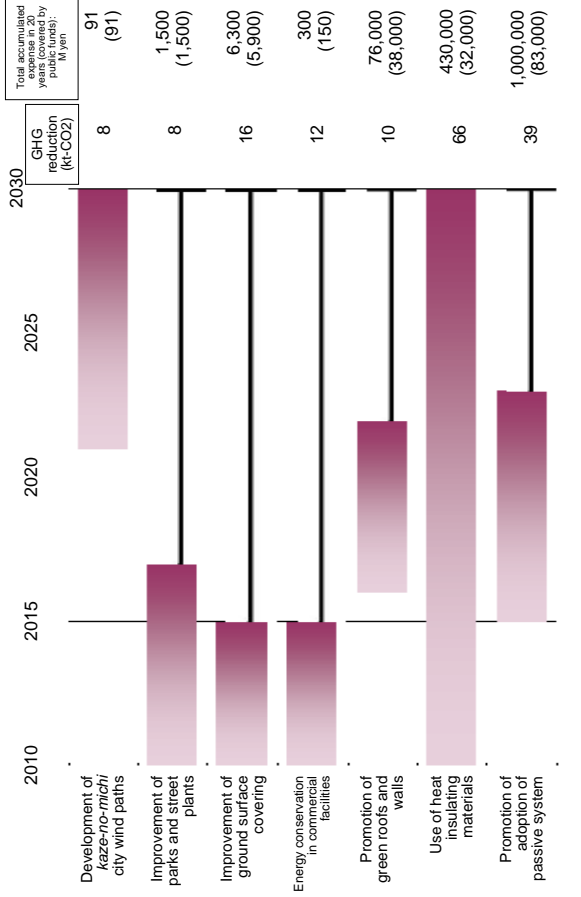

### Composition of Draft Roadmap (2) (Process Chart) - Residents -

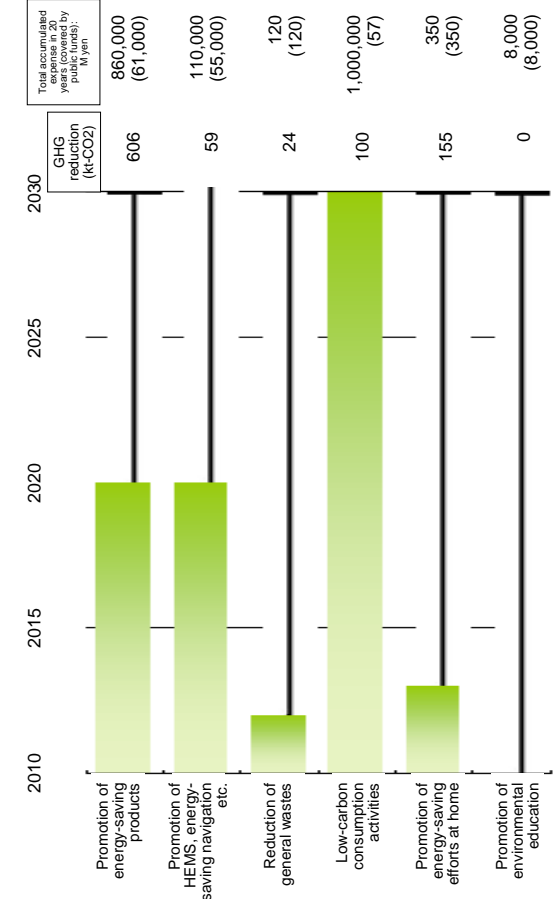

### Composition of Draft Roadmap (2) (Process Chart) - Industrial Activities (1) -

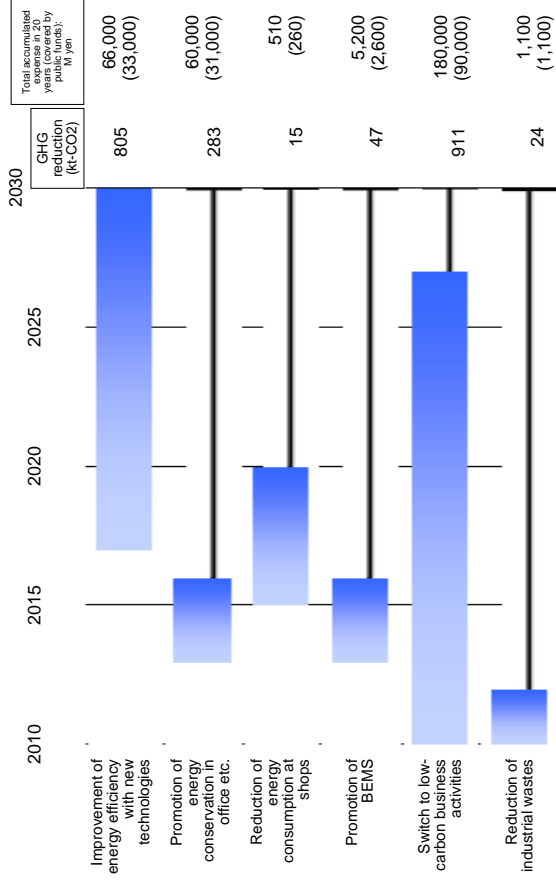

### Composition of Draft Roadmap (2) (Process Chart) - Industrial Activities (2) -

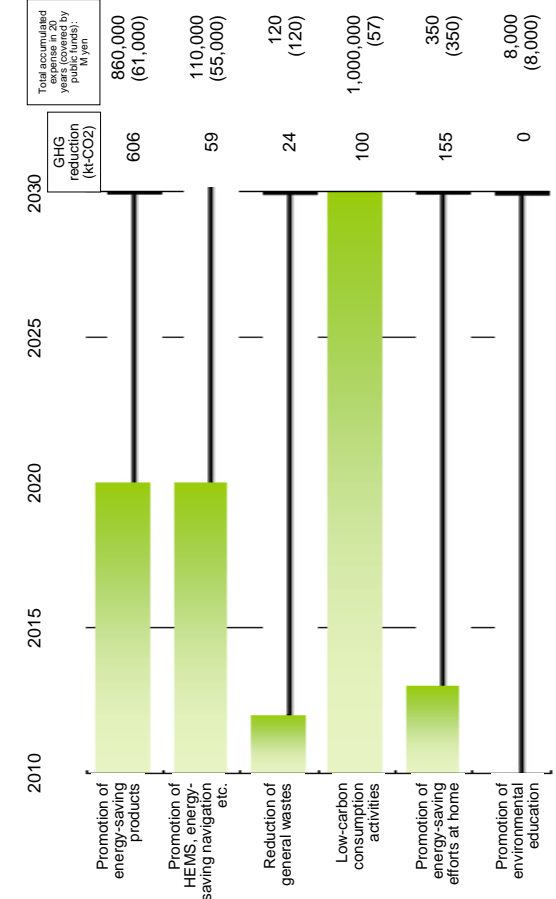

### Composition of Draft Roadmap (2) (Process Chart) - New Energy -

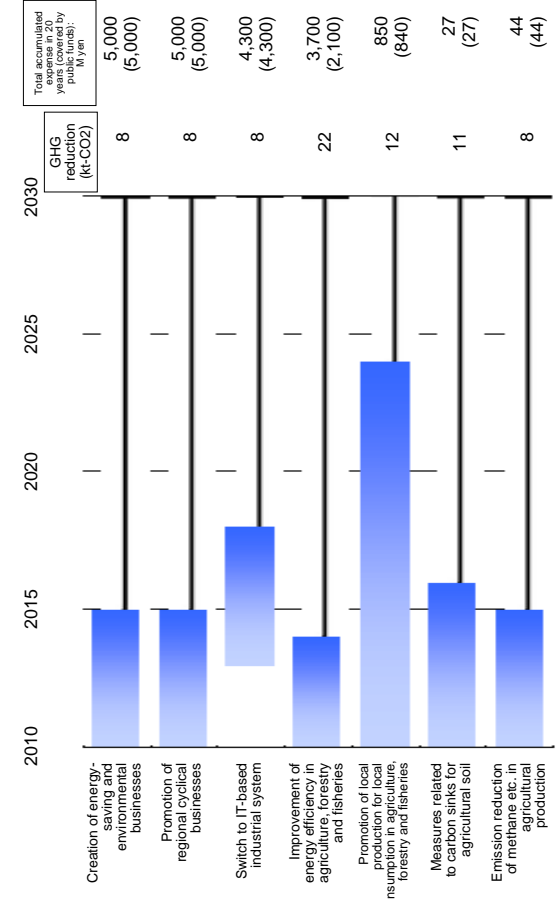



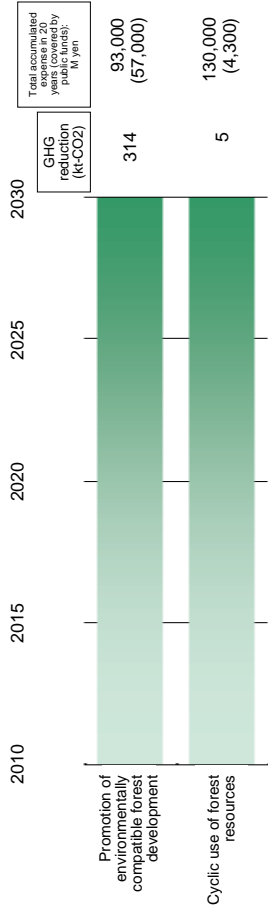

- Purpose of Meeting  
 To have local residents and companies discuss about the revision of the draft roadmap To draw opinions mainly on the following two questions  
 (1) Are the levels of difficulty in implementation leveled out among measures?  
 (2) Is there a link between social changes as a result of measures and the target vision?
- Scheme for Opinion Exchange Meeting  
 (Stance of the prefecture)  
 The draft roadmap was considered as a basis for discussion. Unfavorable opinions should be positively sought.
- (Development of Materials)  
 It was difficult to see social changes with a roadmap that only showed implementation timing and size of projects. Therefore, the prefecture created additional materials such as a time-sequence diagram of changes that would be made by implementation of measures. Illustrations were drawn from a viewpoint of daily life.
- (Handling of Opinions)  
 Prefecture decided to have the participants come up with such ideas as revisions, proposal of measures and issues to be solved in the community and to have overall consistency of the roadmap and other technical matters dealt with by the prefectural government.

**Example of Materials used in Opinion Exchange Meeting**

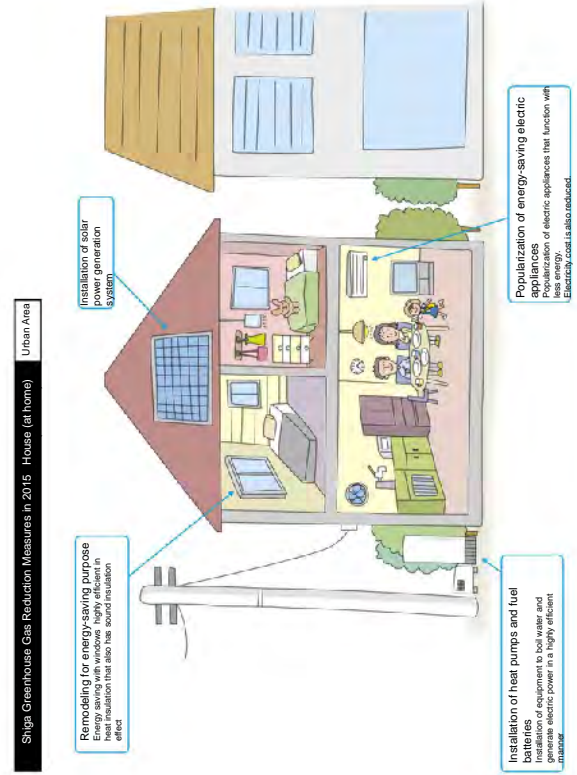
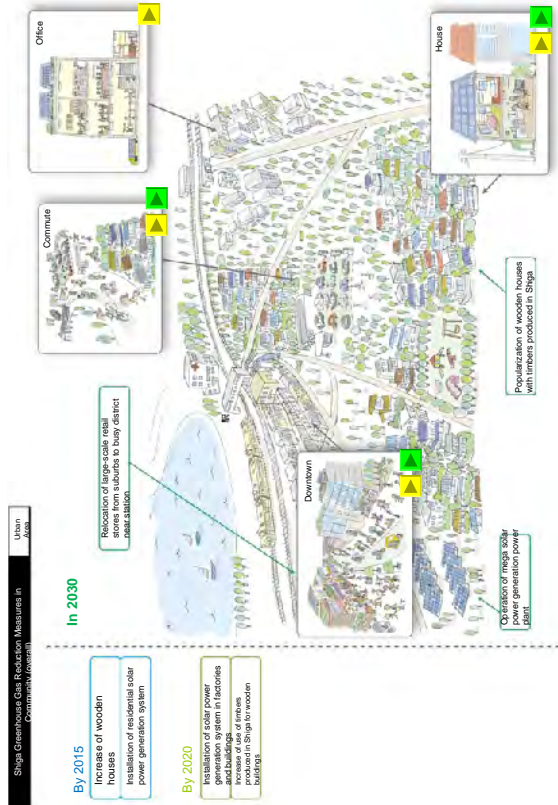

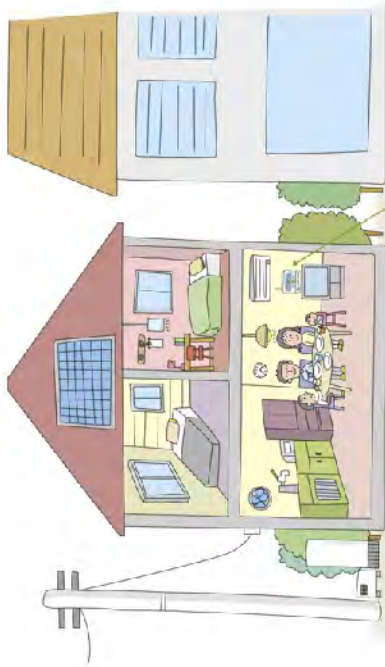

**Widespread use of energy saving navigation**  
 Widespread use of a device to indicate achievement level of energy saving target as well as energy consumption and CO2.

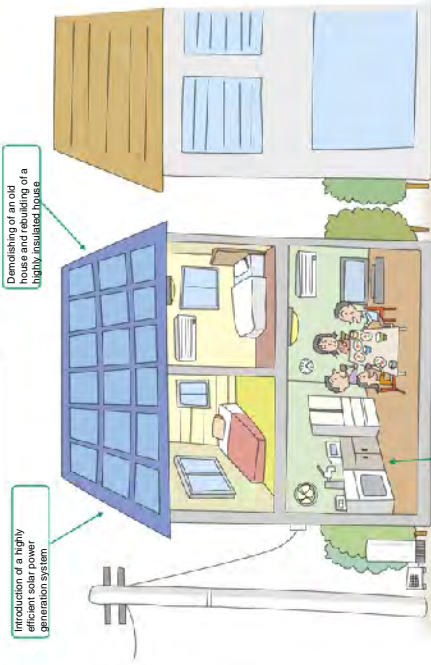

Introduction of a highly efficient solar power generation system

Demolishing of an old house and rebuilding of a highly insulated house.

**Widespread use of HEMS**  
 Home energy management system  
 Widespread use of a system to automatically control electric appliances and water heater according to the status of use.

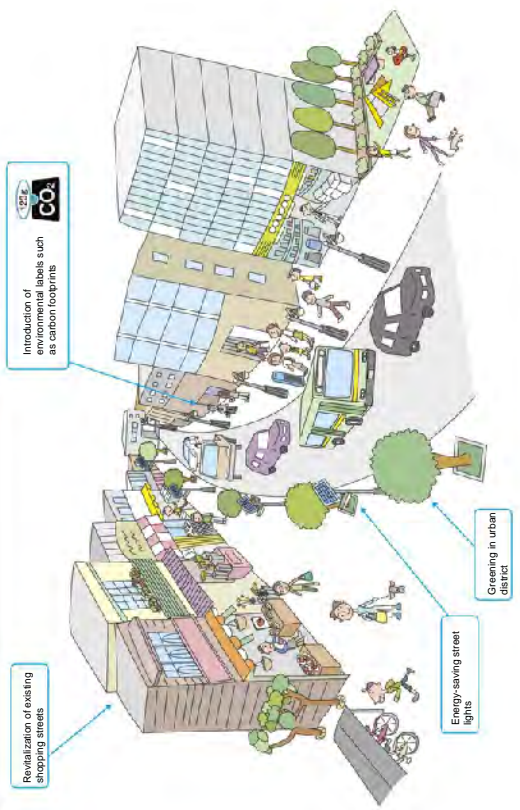

Revitalization of existing shopping streets

Introduction of environmental labels such as carbon footprints

Energy-saving street lights

Greening in urban district

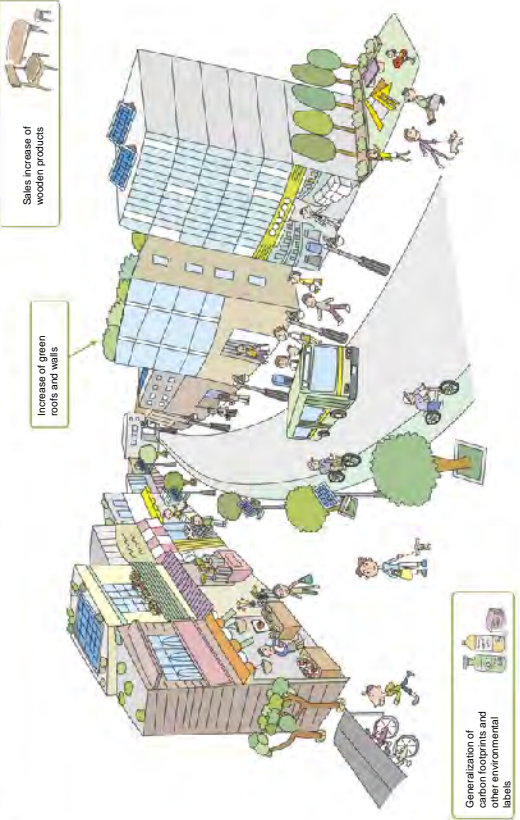

Generalization of carbon footprints and other environmental labels

Increase of green roofs and walls

Sales increase of wooden products

## Issues Identified through Opinion Exchange with Residents

- ✓ First, the residents have a passive belief that they are asked to understand the measures the prefecture wants to implement. Therefore, it requires time to realize they are asked to give opinions as roadmap planners.
- ✓ If a roadmap includes replacement of equipment and such other measures whose major purpose is not to prevent global warming, they might think the government is trying to force them to carry out such measures.
- ✓ As people think that issues relating to the future of the community or home and low carbon society are totally different matters, they are often at a loss about how to have discussion.
- ✓ As they are concerned about the gap between their future vision and the reality, they are often skeptical about future images such as low carbon society.
- ✓ It is difficult for local people to take a broad view of the measures but they tend to discuss more concrete methods.
- ✓ It is difficult for them to think 20 years ahead.

## Use of Roadmap

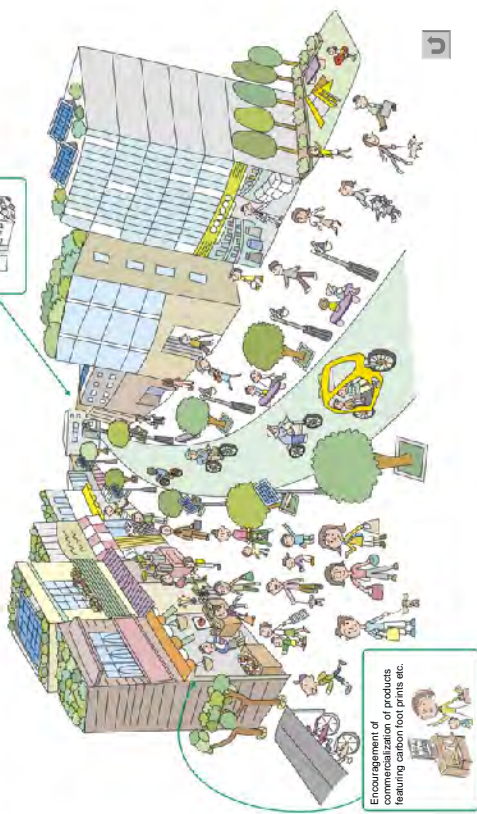
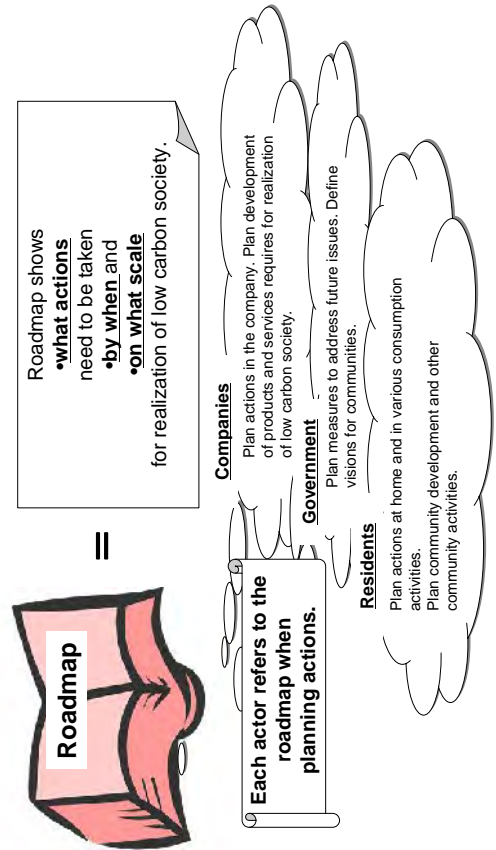

## Proposal of New Environmental Tax

- Regarding funding issues that require discussion on a national basis, the prefectural government proposes measures to the central government based on concrete information obtained through the process of roadmap development.

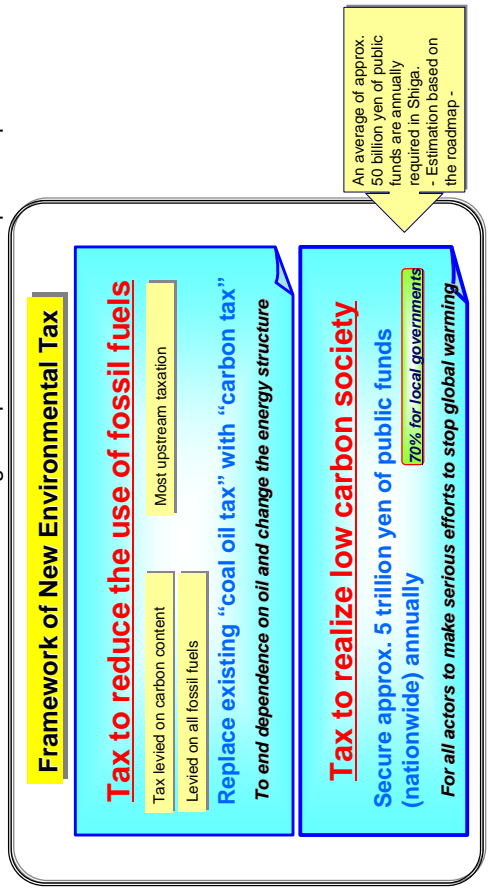

## Examples of Efforts in Shiga (1)

### ■ Miru Eco Ohmi

To promote countermeasures against global warming at home, a website called "Miru Eco Ohmi" was launched in November 2008.



This website is to "miru" (view) CO<sub>2</sub> emission reduction by keeping such records as energy saving activities and energy consumption at home for the purpose of continuing efforts for CO<sub>2</sub> emission reduction in households.

## 4. Actual Examples of Efforts to Realize Low Carbon Society

## Examples of Efforts in Shiga (2)

### ■ Global Warming Prevention Activity Promoters

Law concerning the Promotion of the Measures to Cope with Global Warming stipulates that prefectural governors may delegate persons to serve as global warming prevention activity promoters who are enthusiastic and knowledgeable concerning dissemination of global warming prevention measures and promotion of global warming prevention activities. In Shiga, 79 promoters are carrying out dissemination activities in communities such as lectures at school and companies.



## Examples of Efforts in Shiga (3)

### ■ Introduction of Electric Cars

In December 2009 the prefecture introduced two electric cars as official cars that do not emit greenhouse gases when moving as part of its initiative to achieve the target of reducing greenhouse gas emission by 50% by 2030 as announced in the 3<sup>rd</sup> Shiga Prefecture Comprehensive Environment Plan.



Construction of charging stations will start across Shiga in FY2010.

## Examples of Efforts in Shiga (4)

### Promotion of Solar Power Generation

In FY2005 Shiga became the first prefecture in Japan to provide subsidy on the amount of surplus electricity that is not consumed at home but sold to utility companies in the "Program to Promote Shiga Model for Solar Power Generation System Promotion".

The prefecture also subsidized installation of domestic solar power generation system in the "Project to Support Introduction of Domestic Solar Power System in Shiga" in FY2009, and subsidizes installation of domestic solar power system combined with insulation construction for energy saving as "Subsidy to Promote Solar Power Generation, Energy Saving and Greening in Private Houses in Shiga".

Trend in installed domestic PV capacity in Shiga

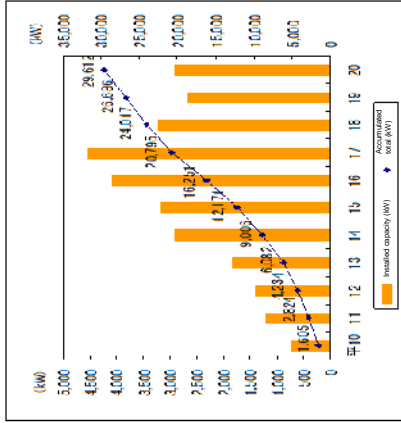

## Examples of Efforts in Shiga (5)

### Support to Cities and Towns

The City of Higashiohmi has been actively conducting activities to realize low carbon society such as "Joint Power Generation Plant" for solar power generation with investments of city residents, and "Nanohana Eco Project" to recycle waste edible oil to biodiesel fuel.

At the prefectural level, the Lake Biwa Environmental Research Institute cooperates with the city in its activities. The prefectural government also supports the activities of the city as a model city for the project to support sustainable community development in Shiga.



# Measures to mitigate climate change by the Ministry of Land, Infrastructure, Transport and Tourism (MLIT)

May 18, 2011



Ministry of Land, Infrastructure, Transport and Tourism

## CO<sub>2</sub> emission in the world

### Share of energy-derived CO<sub>2</sub> emission by country (2008)

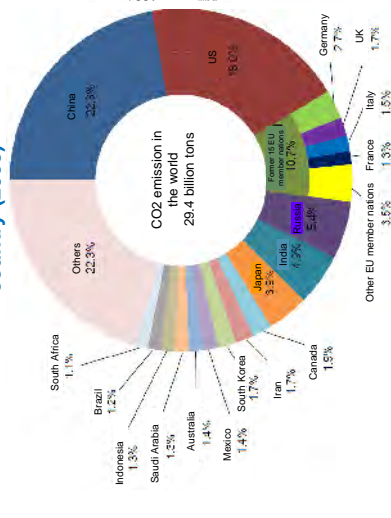

\* 15 EU countries are member countries of EU when COP3 (meeting in Kyoto) was held.  
Source: Developed by the Ministry of the Environment based on "KEY WORLD ENERGY STATISTICS" in 2010 by IEA

### Outlook of CO<sub>2</sub> emission in the world



(Source) Research Institute of Innovative Technology for the Earth (RIITE)

# 1. Present status surrounding global warming in Japan



Ministry of Land, Infrastructure, Transport and Tourism

## Status of greenhouse gas emission in Japan (Definite value in 2009)

Emission in Japan in 2009 was lowered by 4.1% and 3.5%, compared to the levels of the base year and commitment of Kyoto Protocol (6% reduction compared to the level in 1990), respectively.

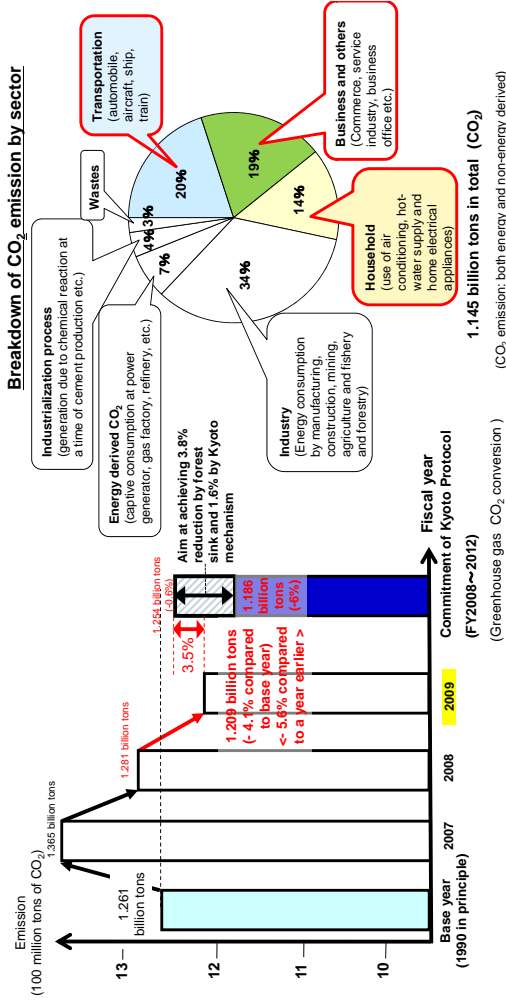

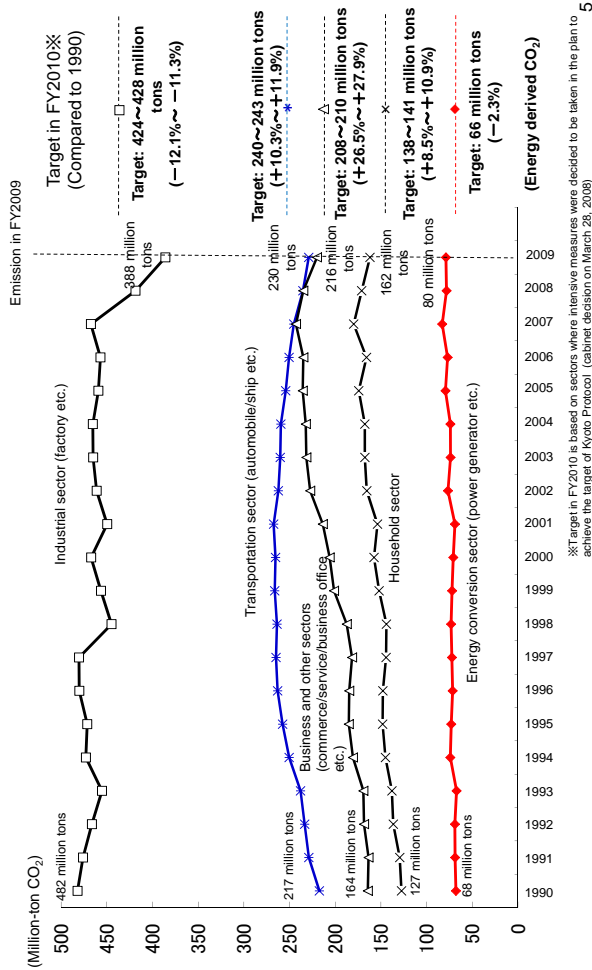

- CO<sub>2</sub> emission from **transport sector constitutes 20%** of the total CO<sub>2</sub> emission in Japan.
- 87.8%** (17.6% of CO<sub>2</sub> emission in the country) of CO<sub>2</sub> emission by transportation sector is attributable to **automobiles**, out of which **34.1%** (6.8% of CO<sub>2</sub> emission in the country) is emitted by **motor trucks**.

CO<sub>2</sub> emission in Japan by sector

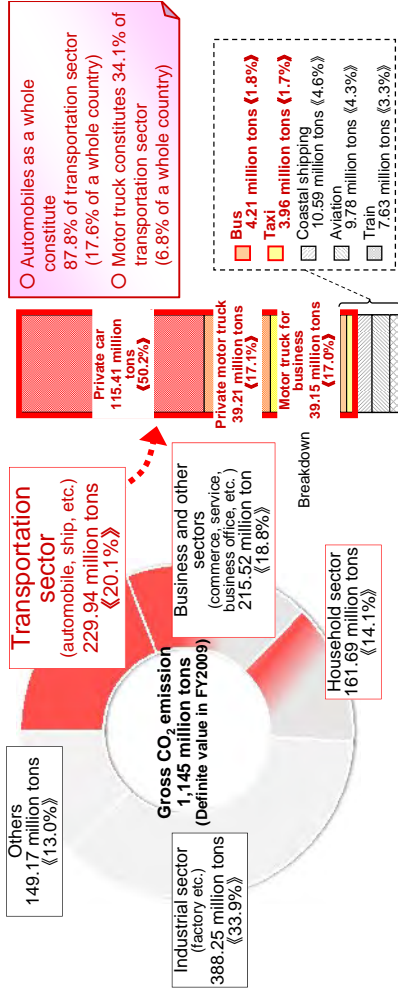

※Emissions by power generation by electric power supplier and heat generation by heat supplier were allocated to final demand sector based on volume of consumption.  
 ※ Developed by Environmental Policy Division of MLIT based on "National Greenhouse Gas Inventory Report of Japan" by Greenhouse Gas Inventory Office

- After peaking in FY2001, emission at transportation sector started to decline.
- Emission from motor trucks and private cars started to decrease after peaking in FY1996 and FY2001, respectively.

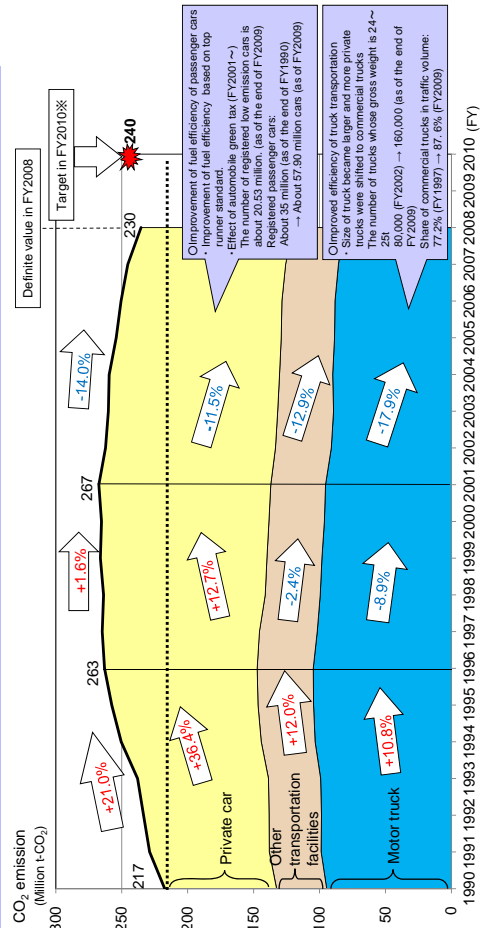

Other transportation facilities: bus, taxi, train, ship and aviation  
 ※Target of FY2010 is based on sectors where intensive measures were decided to be taken in the plan to achieve the target of Kyoto Protocol (cabinet decision on March 28, 2008).

2. Measures of MLIT to counter global warming

- OPromotion of development and spread of low emission vehicles
- OAAlleviation of traffic congestion and encouraging the use of public transportations and motorcycles
- OPromotion of green logistics
- OPromotion of the development and spread of energy saving railcars, etc.
- OImprovement of energy saving performance of houses and other buildings

《Mid-and-long term target》

- ◆Target of greenhouse gas reduction: Achieve reduction of 25% by 2020 and 80% by 2050 (compared to the level in 1990 for both targets), respectively based on the assumption that a fair and effective international framework would be established and an ambitious target would be agreed upon.
- ◆Achievement of 10% share of renewable energy out of primary energy supply (2020).

《Basic plan》

- ◆Formulation of a plan for comprehensive and systematic promotion of global warming countermeasures

《Specific measures》

◆(Measures at local areas)

- ◆Integration of urban function, etc. for the creation of regional community
- ◆Promotion of energy saving in buildings, etc.
- ◆Preservation and strengthening of absorption capacity of greenhouse gas by forest improvement and green greening
- ◆Taking of necessary measures required by local public agencies

◆(Production)

- ◆Promotion of positive technological development
- ◆Promotion of energy saving in machinery and appliances, buildings, etc.
- ◆Switch to energy with less greenhouse gas emission and promotion of efficient use of fossil fuels
- ◆Creation of new businesses that contribute to prevent global warming

◆Measures related to nuclear power

- ◆Adaptation to global warming
- ◆etc.

◆(Everyday living)

- ◆Promotion of energy saving in transportation sector like automobiles, buildings, etc.
- ◆Promotion of education and learning opportunities
- ◆Public announcement of information about emission status, etc.

◆(International collaboration, etc.)

- ◆Creation of opportunities and promotion of international collaboration

—MLIT related measures incorporated in the bill—

(Article 17) Promotion of the spread of energy-saving equipment (transportation sector such as automobile, construction machinery), and promotion of energy-saving houses and buildings

(Article 18) Improvement of the efficiency of logistics by eco-drive, smooth road traffic, modal shift, etc., and encouragement of the use of public transportation (compact city)

(Article 26) Intensification of urban function (compact city)

(Article 27) Preservation of green lands, promotion of greening, etc. (urban park)

(Article 28) Measures to adapt to global warming (against tidal wave, flood, etc.)

■ **Transportation sector**

**Automobile/road traffic**

"Measures to be taken to automobiles"

- ◆Establish a new fuel efficiency standard for passenger cars toward 2020
- ◆Secure proper incentive to spread the use of environment-friendly cars
- ◆Develop next generation heavy vehicles (bus/truck) and put them into practical use
- ◆Establish an international standard for automobile
- ◆Improve the usage of cars by promoting eco-drive, etc. etc.

"Traffic flow improvement"

- ◆Development of a network of arterial roads including orbital roads
- ◆Improve environment for bicycle riding, measures against bottleneck
- ◆Promotion of Intelligent Transport System (ITS), etc.

◆(Promotion of public transportation)

- ◆Improvement of the efficiency of logistics
- ◆Modal shift to railroad and maritime traffic
- ◆Promotion of the development of low carbon ports and harbors
- ◆Fulfillment of green logistics partnership meeting, etc.

- ◆Improvement of new railroad lines
- ◆Encouragement of the use of train/bus and their switch to barrier-free
- ◆Promotion of greening of commuter traffic, etc.

◆(Improvement of the energy consumption efficiency of train/ship/aircraft)

- ◆"Driving of the agreement to "international treaty (ship)"

■ **Urban sector**

**Promote the creation of low carbon city (eco-town)**

- ◆Realization of compact urban structure
- ◆Promotion of district-scale use of energy
- ◆Making sewerage treatment facility a base for renewable energy supply
- ◆Promotion of urban greening, etc."

■ **Others**

- ◆Promotion of the spread of low-carbon construction machinery etc."
- ◆Promotion of the creation of low-carbon society in wide-area"

Promotion of spreading environmentally superior vehicles

1. Preferential measures of car weight tax

Applied to cars subject to vehicle inspection (both new and renewal) prior to April 30, 2012.

E.g.: TOYOTA/CAROLLA : JP¥30,000 (2 years of private use) (main rule JP¥15,000)  
Hino/Prolia (1.6 freight ton) : JP¥7,500 (1 year of private use) (main rule JP¥2,500)

<p>Electric vehicles (including fuel cell vehicles), plug-in hybrid vehicles, green diesel passenger cars, a part of natural gas fueled vehicles, a part of hybrid vehicles</p>	<p>O x x x x vehicles that achieve 25% more than the fuel efficiency standard</p> <p>75% reduction</p>
<p>O x x x x vehicles that achieve 15% more than the fuel efficiency standard</p> <p>O heavy duty x vehicles that meet fuel efficiency standards for heavy weight vehicles</p> <p>O x x x x vehicles that achieve fuel efficiency standards in FY2015</p> <p>Gasoline fueled vehicle with gross vehicle mass from 2.5 to 3.5 tons</p>	<p>50% reduction</p>

3. Preferential measures of car acquisition tax

Applied to cars subject to new vehicle acquisition prior to March 31, 2012.

E.g.: TOYOTA/CAROLLA (priced about JP¥1.9 million) : JP¥85,500 (main rule JP¥1,300)  
Hino/Prolia (priced about JP¥1.6 million) : JP¥432,000 (main rule JP¥432,000)

<p>Electric vehicles (including fuel cell vehicles), plug-in hybrid vehicles, green diesel passenger cars, a part of natural gas fueled vehicles, a part of hybrid vehicles</p>	<p>O x x x x vehicles that achieve 25% more than the fuel efficiency standard</p> <p>75% reduction</p>
<p>O x x x x vehicles that achieve 15% more than the fuel efficiency standard</p> <p>O heavy duty x vehicles that meet fuel efficiency standards for heavy weight vehicles</p> <p>O x x x x vehicles that achieve fuel efficiency standards in FY2015</p> <p>Gasoline fueled vehicle with gross vehicle mass from 2.5 to 3.5 tons</p>	<p>50% reduction</p>

2. Preferential measures of automobile tax

Applied to cars subject to new vehicle registration prior to March 31, 2012.

E.g.: TOYOTA/CAROLLA: JP¥39,500  
Hino/Prolia (1.6 freight ton) : JP¥67,100

<p>Electric vehicles, a part of natural gas fueled vehicles</p> <p>O x x x x vehicles that achieve 25% more than the fuel efficiency standard</p> <p>O plug-in hybrid vehicles</p>	<p>Roughly 50% tax rate reduction</p>
<p>O diesel vehicles of over 11 years in use, gasoline/LPG vehicles of over 13 years in use (excluding electric vehicles, natural gas fueled vehicles, methanol fueled vehicles, general buses and trailers)</p>	<p>Roughly 10% tax rate increase</p>



<Sticker for a 4-star low emission vehicle>

<Sticker for a vehicle that achieves 25% more than the fuel efficiency standard>  
(Gasoline-fueled passenger cars, etc.)

Establishment of new fuel efficiency standard for automobile and the development/spread of environment-friendly car

Contribute to spread global warming with extensive and comprehensive measures like fuel efficiency standard for passenger cars and development/spread of environment-friendly car. At the same time, achieve economic growth by strengthening international competitiveness through the promotion of technological development and by supporting entry of Japanese companies to overseas market through internationalization of the standard.

① **Advancement of integrated approach**

① Improve fuel efficiency, ② Spread of environment-friendly car, ③ Improve the usage, and ④ Low-carbon fuel

→ Reduce CO<sub>2</sub> emission from automobile by comprehensive promotion of the measures ①~④ above (= Advancement of integrated approach).

② **Support for the spread of environment-friendly car at home and abroad by introducing incentives and environmental improvement**

- Securement of appropriate incentives for the spread of environment-friendly car
- Encourage the spread of environment-friendly car through tax system (green tax, etc.)/subsidy (measure of low emission vehicle promotion).
- Internationalization of automobile standard
- Prepare to establish internationally-standardized fuel-efficiency evaluation method
- Formulate uniform international standard on the safety, etc. of electric vehicle.

<Example of safety standard to be verified internationally>

③ **Efforts for fuel efficiency improvement**

- Development of technical standard, etc. of E10 corresponding vehicles
- Develop E10 corresponding technical standard, etc. related to emission gas and prevention of wrong fuel supply, etc.

④ **Improvement etc. of vehicle usage**

- Support the spread of eco-drive management system (EIMS)
- Establish evaluation method, etc. of CO<sub>2</sub> emission reduction efforts by forwarders

① **Improvement of fuel efficiency of new cars through fuel-efficiency requirements, R&D support, etc.**

- Establishment of new fuel efficiency standard for passenger cars
- Facilitate world's top level technological innovation by establishing new fuel efficiency standard for passenger cars based on technical review to achieve the target in 2020.
- Development of the next generation heavy vehicles and putting them into practical use
- Promote the development of the next generation heavy vehicles (aircraft) with drastic improvement of environment performance and put them into practical use.

<Image of any electric vehicle>

<Image of any electric vehicle>



Support the introduction of next generation vehicles (CNG truck/bus, hybrid truck/bus/taxi, electric automobile) by operators of truck/bus/taxi, as a measure to counter global warming and air pollution in urban areas. At the same time, grant subsidy for the introduction of diesel truck/bus with superior environmental performance is added as a measure for economic policy.

**Measures to spread low emission vehicles**

Vehicles subject to subsidy	Ratio of subsidy	
CNG truck/bus	Half of the price difference between normal vehicle of the same type, or one fourth of the vehicle price	
Hybrid truck/bus		
Electric automobile		
Hybrid taxi	※ Amounts of subsidy for environmentally-friendly diesel truck/bus are as follows:	
Included in supplementary budget of FY2010		
Environment-friendly diesel truck/bus	Subsidy	
	3.5 ton class	JPY 100,000
	8 ton class	JPY 250,000
	12 ton class	JPY 600,000
Remodelling of an existing vehicle to CNG vehicle	One third of the remodelling cost	

In addition, provide support for the introduction of electric automobile, etc. at tourist spots.

**Compressed Natural Gas (CNG) vehicle**  
 > Do not emit PM and cut NOx by 50% or more  
 > Require CNG station

**Hybrid vehicle**  
 > Retain two power sources of internal combustion and motor  
 > Do not require development of a new infrastructure

**Electric vehicle**  
 > Zero emission of NOx/PM, CO<sub>2</sub>

**Environment-friendly diesel vehicle**  
 > Achieve fuel efficiency standard of FY2015 and meet new long-term standards for emissions

- Improve effective fuel efficiency by realizing smooth traffic flow, thereby reduce emission of CO<sub>2</sub> from automobile.
- In order to smoothly implement the plan to achieve the target of Kyoto Protocol, develop a network of arterial roads including orbital roads, improve environment for bicycle users, promote ITS, resolve the issue of bottleneck railroad crossing etc. and continuously reduce CO<sub>2</sub> emission.

**Examples of main measures**

Improve environment for bicycle users



- Reallocate road space to give way for cycling and facilitate switch from car to bicycle.

Promote Intelligent Transport System (ITS)



- Promote the spread of VICS.
- Reduce emission by improving drive speed with alleviated congestion.

Resolve bottleneck railroad crossing issue, etc.



- Reduce emission by improving drive speed with alleviated congestion.

Support the introduction of next generation vehicles (CNG truck/bus, hybrid truck/bus/taxi, electric automobile) by operators of truck/bus/taxi, as a measure to counter global warming and air pollution in urban areas. At the same time, grant subsidy for the introduction of diesel truck/bus with superior environmental performance is added as a measure for economic policy.

**Measures to spread low emission vehicles**

Vehicles subject to subsidy	Ratio of subsidy	
CNG truck/bus	Half of the price difference between normal vehicle of the same type, or one fourth of the vehicle price	
Hybrid truck/bus		
Electric automobile		
Hybrid taxi	※ Amounts of subsidy for environmentally-friendly diesel truck/bus are as follows:	
Included in supplementary budget of FY2010		
Environment-friendly diesel truck/bus	Subsidy	
	3.5 ton class	JPY 100,000
	8 ton class	JPY 250,000
	12 ton class	JPY 600,000
Remodelling of an existing vehicle to CNG vehicle	One third of the remodelling cost	

In addition, provide support for the introduction of electric automobile, etc. at tourist spots.

**Compressed Natural Gas (CNG) vehicle**  
 > Do not emit PM and cut NOx by 50% or more  
 > Require CNG station

**Hybrid vehicle**  
 > Retain two power sources of internal combustion and motor  
 > Do not require development of a new infrastructure

**Electric vehicle**  
 > Zero emission of NOx/PM, CO<sub>2</sub>

**Environment-friendly diesel vehicle**  
 > Achieve fuel efficiency standard of FY2015 and meet new long-term standards for emissions

**Development of new railway line, etc.**  
 Encourage the use of the existing railroads/buses

○ New urban rail lines opened during FY2003-2008



○ Utilization of IT technology  
 -IC card ticket system was introduced to 70 railroad operators as of end-March 2009 and introduced to 106 bus operators as of end-March 2008.



○ Promotion of LRT development

◇ Toyama light rail (about 8km in total) (Opened on April 29, 2006)  
 ◇ LRT development is envisaged in areas of Echigo, Niigata, Iwate, Fukuoka and Okayama



○ Improved the connectivity of railroad and bus for enhanced usability

Improved the connectivity of Hiroshima electric railway Miyajima line and Hitoden bus, which connects new housing complex, and Sakura City Bus which circulates in Hatsuoka City.



○ Enhanced the usability of public transportation facilities

- Introduction of bus location system (As of end-March 2008)
- Introduction of low-floor bus (As of end-March 2009)



**Efforts of ecological commuting made by Onomichi Plant of Nitto Denko Corporation**

~Minister's 2009 commendation for superior business operators who advanced environmental preservation in transportation area~

Onomichi Plant of Nitto Denko (Industrial complex of Onomichi)  
 Onomichi Station  
 Higashi Onomichi Station  
 Matsunaga Station  
 Onomichi Station  
 Onomichi Station

Bus routes  
 62 outward services for 3 destinations (JR Onomichi Station, Higashi Onomichi Station and Matsunaga Station) and 63 return services (Set up by Nitto Denko and donated to Onomichi city)

Most employees of about 2,000 at the plant commuted on private cars because there is no public transportation routes available in the area. Degraded the surrounding environment due to congestion, etc.

- Vision of Onomichi Plant involving commuting means of employees
1. Aim at creating a community-based plant by easing local traffic jam.
  2. Lower the risk of traffic accident to protect the security of employees.
  3. Reduce private car commuting by employees as an environmentally-friendly plant = ecological plant.
  4. Increase productivity of the site area through effective utilization of the plant premise.

February 2007 Introduced private commuting bus for the employees (Quoted from the operation to Onomichi City Bus (Inseent Onomichi Bus Co., Ltd.)  
 Set up bus stops in front of the plant headed to different destinations.  
 April 2009 Transformed the private bus to shuttle bus and made the service open to public. Contributed to provide transportation means for residents in the area.

- About 900 employees switched to commuting on the bus (Cutback of about 1,200 ton CO<sub>2</sub> per year)
- Reduced the occurrence of accidents during commute (36 accidents in FY2006 ⇒ 21 in FY2008)
- About 90 people (excluding plant employees) uses the bus service per day (as of June 2009)

As an initiative of realizing EST, selected 27 model areas where the use of public transportation facilities is encouraged and traffic flow of automobiles is improved from FY2004 to FY2006, with intensive supports from related ministries, departments and agencies. In the future, deploy the initiative of the 27 EST model areas across the country and realize national-scale EST.

**Voluntary efforts at local level**

Voluntary efforts at local level by exploiting the local feature to achieve environmental improvement target (CO<sub>2</sub> reduction, etc.)  
 Promote projects with extensive cooperation among local players, like local governments, local shopping mall/commercial facilities, transportation operators, road administrator, police and NPC.

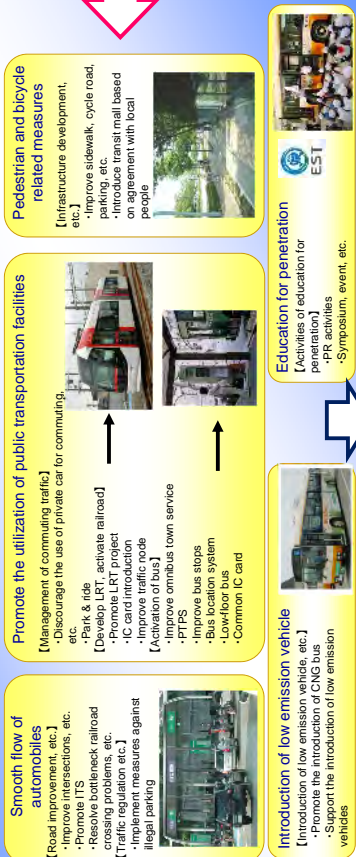

**Penetrate EST nationwide in collaboration with related ministries and agencies, by providing information on successful EST introduction cases, etc. to local areas which make voluntary efforts to realize EST by making use of their local features.**

Reduce CO<sub>2</sub> emission in logistics section by modal shift and other efforts for greening logistics.

**Improve the efficiency of transportation**

**Optimize efficient cargo transport** (Shorten transportation distance, etc.)  
 -Transportation Efficiency Act (Integrate distribution center and promote efficient operation)  
 -Green distribution partnership conference (promote modal shift of shipper and distribution company to reduce CO<sub>2</sub> emission, develop an action plan to promote modal shift)  
 -Project to drive modal shift, etc. (support the promotion of modal shift, etc. in collaboration with various parties concerned)  
 -Law on the efficient use of energy (obligation for shippers and distribution companies to make sincere efforts to lower energy-use related basic unit by 1% or more per year in medium-to-long term basis)

**Modal shift to railway/maritime transportation**

**OSwitch to transportation mode with smaller environmental load**  
 -Modal shift to railway freight (Project to strengthen transportation capacity between Kita Kyushu and Fukuoka, and at Suido River station)  
 -Secure alternative transportation means to railway to be prepared for interruption due to disaster, etc.  
 -Efforts to strengthen competitiveness of ferry/coastal shipping  
 -Measures at ports and harbors to promote modal shift to maritime transportation (Promote improvement of intermodal transportation terminal and making a plan to reduce greenhouse gas emission at ports and harbors)  
 -Transportation Efficiency Act [forementioned], Green Distribution Partnership Conference [forementioned], Project to promote modal shift, etc. [forementioned], Law concerning the Rational Use of Energy [forementioned]

**Improve load efficiency of freight**

**OPromote efficient truck transportation (shift from private to commercial trucks, increase in the size of vehicles, joint transportation/distribution, etc.)**  
 -Transportation Efficiency Act [forementioned], Green Distribution Partnership Conference [forementioned], Law concerning the Rational Use of Energy [forementioned]

**Improve energy efficiency, etc.**

-Improve energy efficiency such as eco-drive, etc.  
 -Promote the spread of trucks, locomotives and ships which contribute to lower environmental load  
 -Law concerning the Rational Use of Energy [forementioned]

**Point: Effective use of regeneration brake and electric storage**

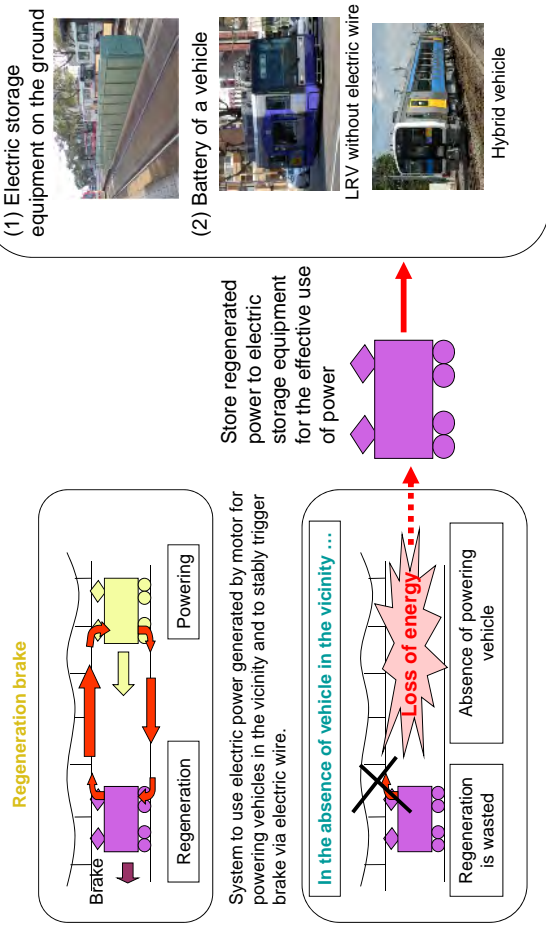

**Diesel hybrid**

- Powered by: engine + battery (lithium-ion)
- Challenges to be addressed: reduction of cost and vehicle weight



JR East Japan <sup>1)</sup>

JR Hokkaido

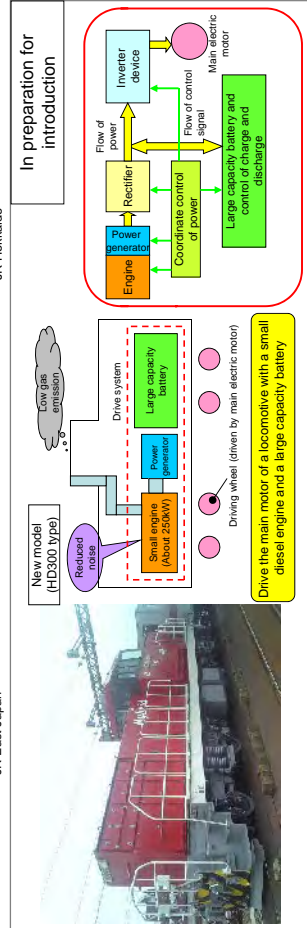

JR cargo

<sup>1)</sup> In commercial service at Koumi Line since July 2007. (a two-car train)

**Electric storage device**

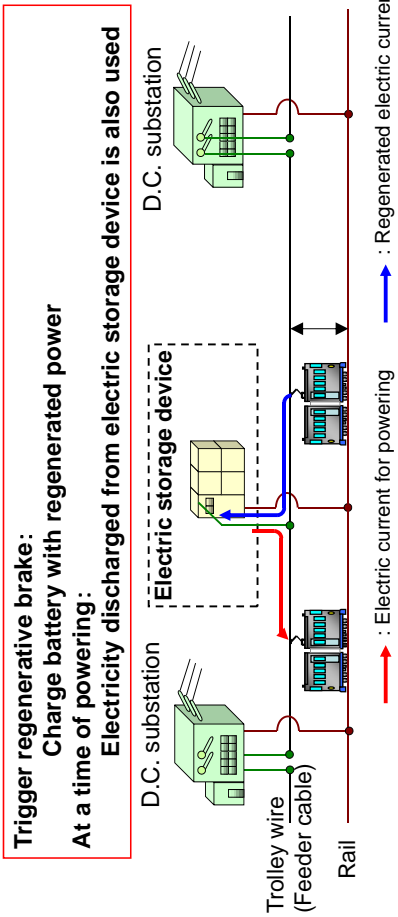

**Housing**

The next generation standard of energy efficiency of housing (current)  
(Example of specification for a wooden single-family house in Tokyo)

- ◇ Ceiling insulation Insulator (glass wool) (Thickness: 100mm or more)
- ◇ Outer wall insulation Insulator (glass wool) (Thickness: 100mm or more)
- ◇ Window insulation Double glass
- ◇ Others Standard for airtightness Standard, etc. for preventing solar insulation

○ Introduction of energy-saving equipment  
-Use highly efficient illumination

○ Outer wall, etc. insulation

○ Core of outer insulation  
-Use highly efficient insulation

○ Evaporator energy saving type equipment

○ Other water supply facility Apply energy-saving type insulation of pipe

○ Air conditioning equipment  
-Use highly efficient air conditioning equipment  
-Improve the control of air conditioning load

**Building**

○ Introduction of energy-saving equipment  
-Use highly efficient illumination

○ Outer wall, etc. insulation

○ Core of outer insulation  
-Use highly efficient insulation

○ Evaporator energy saving type equipment

○ Other water supply facility Apply energy-saving type insulation of pipe

○ Air conditioning equipment  
-Use highly efficient air conditioning equipment  
-Improve the control of air conditioning load

○ In order to further drive global warming countermeasures, it is necessary to strengthen measures to improve energy efficiency at households and business operators where drastic increase of energy consumption is taking place.  
○ Accordingly, promote measures to improve energy efficiency of houses and buildings based on Revision Law Concerning Rational Use of Energy

Revision Law Concerning Rational Use of Energy (1989, 2002, 2005, 2008)  
○ Strengthening of standard for rational use of energy (1989)  
○ Obsolescence of standard and a large-scale refurbishment of houses/buildings that exceed the predetermined size (2002, 2005, 2008)

**Law**  
Obsolescence of standard, extension, reconstruction and a large-scale refurbishment of houses/buildings that exceed the predetermined size (2002, 2005, 2008)  
○ Review of new standard, which is tighter than the current standard set in 1989

<b>Tax system to promote remodeling to energy efficient housings/buildings</b>	<b>Green investment tax system</b>	<b>Tax system</b>
Support housing/building projects that contribute to the education for penetration of CO <sub>2</sub> emission reduction technology, introduction of energy-saving construction technologies, etc. by small and medium-sized enterprises, etc.	Support housing/building projects that contribute to the education for penetration of CO <sub>2</sub> emission reduction technology, introduction of energy-saving construction technologies, etc. by small and medium-sized enterprises, etc.	Support through securitized loan, eco-point for housing, etc.
Development and penetration of Comprehensive Assessment System for Built Environment Efficiency (CASBEE)	Support the development of leading technology	Performance evaluation
Support the development of leading technology	Photovoltaic power generation/energy saving at government office buildings, improvement of green government office buildings, utilization of CEM	Technology development
		Public buildings 2b

Promote energy-saving housings/buildings including the use of equipment and energy control system, not limited to insulation characteristics improvement. Also, adopt energy-saving structure to new housings/buildings by 100%, to drastically increase the stock of energy-saving constructions. At the same time, promote zero-emission housings/buildings, or realize ecological housings/buildings, in a bid to reduce CO<sub>2</sub> in both "household sector" (housing) and "business and other sectors" (building).

**Contents of measures**

- **Develop a progress chart to realize energy-saving housings/buildings**
  - Develop a "progress chart" which clarifies the overall policy to adopt energy-saving structure to new housings/buildings by 100%, and to improve energy efficiency of the existing buildings, for the realization of Challenge 25.
  - Diagnostic/evaluation/display of eco-label, etc. and spread related services
- **"Ecological" housings/buildings**
  - Support spread of ecological housings/buildings
  - Promote "ecological" housings/buildings by improving the "visibility" of energy-saving performance and through "zero-emission", etc.
  - Tighten energy saving standard for large-scaled constructions etc.
- **Promote the supply of wooden show houses/buildings**
  - Support construction of wooden show houses and display information at wooden houses
  - Standardization of forms for wooden housings/buildings
  - Promote the use of woods for public constructions, etc.
- **Improve operation to facilitate rehabilitation contributing to improve city environment**
  - Improve operation of integrated design system to facilitate rehabilitation of buildings based on superblock, etc.

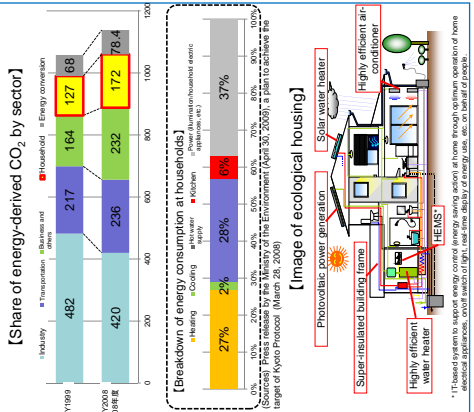

Promote measures by supporting proposals of leading projects, etc. contributing to CO<sub>2</sub> emission reduction from housings/buildings and extend longevity of houses.

Enhance energy efficiency of housings/buildings based on insulation performance, etc.	Extend longevity of housings with improved durability
<p>① <b>Leading project to reduce CO<sub>2</sub> emission from housings/buildings</b></p> <p>Support for leading projects of housings/buildings contributing to the education to penetrate CO<sub>2</sub> emission reduction technology</p> <p>○ Main target of subsidy -Improvement of constructions, etc. based on leading technology to reduce CO<sub>2</sub> emission -Verification of effectiveness, etc.</p> <p>○ Ratio of subsidy 1/2</p>	<p>② <b>Project to refurbish housings/buildings for improved energy efficiency</b></p> <p>Support for projects to enhance energy efficiency by reducing energy consumption of the whole housings/buildings by 10%.</p> <p>○ Main target of subsidy -Refurbishment to improve energy efficiency -Verification of effectiveness, etc.</p> <p>○ Ratio of subsidy 1/3</p>
<p>③ <b>Leading project of long-term excellent house</b></p> <p>Support for leading projects of housings contributing to the education to penetrate long-term excellent house</p> <p>○ Main target of subsidy -Construction of housings (including refurbishment) -Verification of effectiveness, etc.</p> <p>○ Ratio of subsidy 2/3</p>	<p>④ <b>Leading project of long-term excellent house</b></p> <p>Support for leading projects of housings contributing to the education to penetrate long-term excellent house</p> <p>○ Main target of subsidy -Construction of housings (including refurbishment) -Verification of effectiveness, etc.</p> <p>○ Ratio of subsidy 2/3</p>

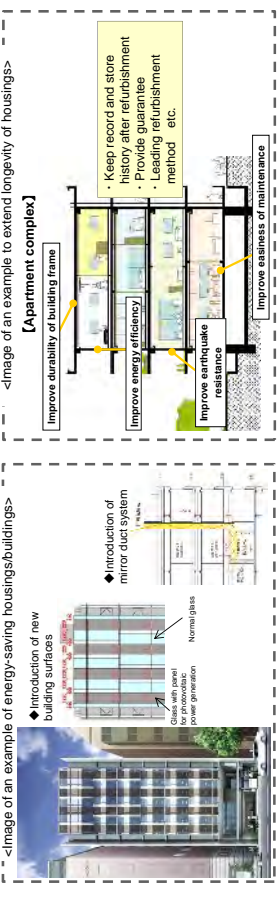



Transformation Towards Low Carbon City Infrastructure  
-The Challenge of Yokohama, Environmental Model City

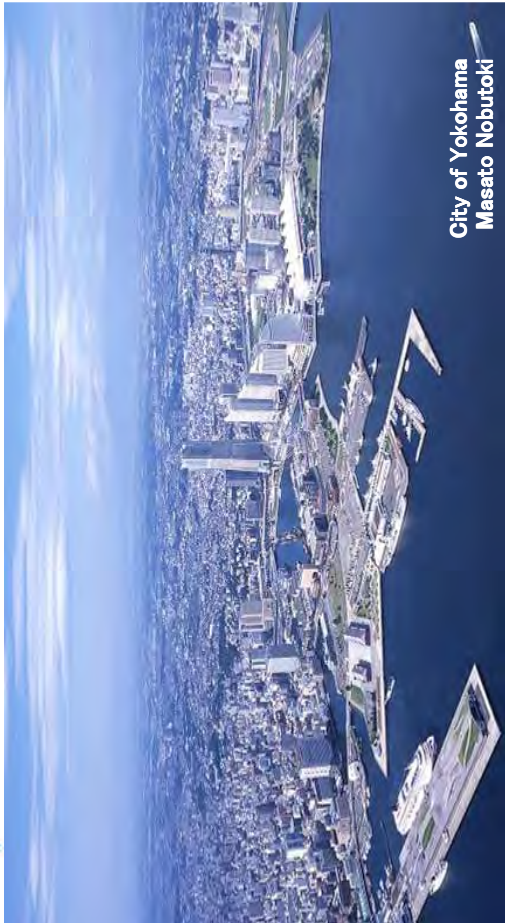

City of Yokohama  
Masato Nobutoki



Yokohama

- ◆ Historic port town founded on the arrival of Commodore Perry( 1859)
- ◆ 30 km South of Tokyo
- ◆ One of six “super ports”,
- ◆ 20 minutes from Haneda international airport
- ◆ 2nd largest city in Japan
- ◆ Population:36 million , 437 km<sup>2</sup>
- ◆ 40% GDP of Kanagawa Prefecture



Yokohama is..

Diverse

- Geographic: ocean, harbor and hills, urban center, new developments, old town
- Largest chinatown in the world, 3rd largest population of expatriates



Innovative

- Birthplace of silk, telephone, railway, sewage system, icecream, dry cleaning
- Home for multi-nationals, local venture industries



Creative

- City where people came to create change
- 80% participation rate in local governance, 9<sup>th</sup> in the nation for NPOs, Yokohama Eco School
- 1000 participants in Open Yokohama event



Climate Change in Yokohama

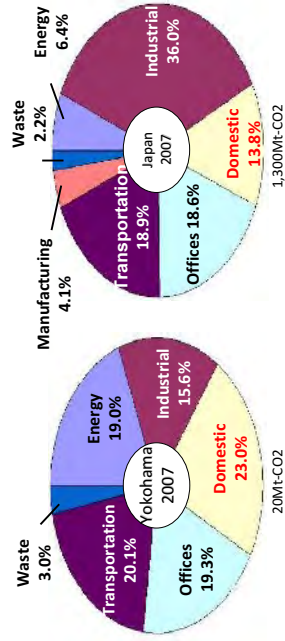

Wealth of Successful Initiatives

- ◆ G30
- ◆ Hama Wing(wind power plant)
- ◆ Partnership Between Urban and Rural Areas
- ◆ Biodeisel Fuel Programme
- ◆ Solar Power Programme for Schools
- ◆ Environmental Accounting for Homes
- ◆ Kids Energy Efficiency Challenge
- ◆ LED Lighting Programme
- ◆ Yokohama Green Valley
- ◆ Yokohama Green Power
- ◆ Yokohama Mobility Project Zero

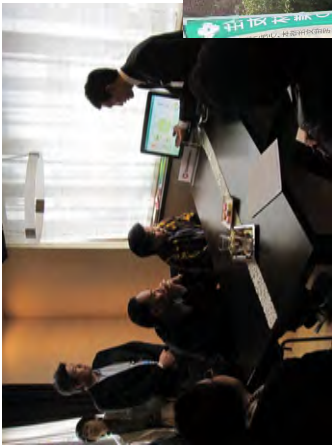

**His Excellency Mr. Kasit Piromya,  
Minister of Foreign Affairs  
of the Kingdom of Thailand**