

**ROAD NOTES:**

1. THE CONTRACTOR SHALL ATTEND TO ANY WORKS SPECIFIED IN T WITH ALL APPLICABLE STANDARDS OF SAFETY COMMENSURATE W WORKING PRACTISE.
2. WHERE APPLICABLE, ROAD CONSTRUCTION WILL COMPLY WITH ALL STANDARDS.
3. ALL DIMENSIONS ARE IN MILLIMETRES UNLESS NOTED OTHERWISE.
4. ALL DESIGN LEVELS REFER TO FINISHED LEVELS UNO.
5. ALL SETOUT INFORMATION RELATES TO THE INTERSECTION POINTS STRAIGHT LINE WITHIN THE STP.
6. THESE DWGS. ARE TO BE READ IN CONJUNCTION WITH ARCHITEC STRUCTURAL & SERVICES DWGS.
7. SPOT LEVELS SHOWN ARE FOR FINISHED SURFACE LEVEL.
8. THE CONTRACTOR SHALL ENSURE THAT ALL SURFACES FALL CON IN BETWEEN STATED POINTS WITH SMOOTH TRANSITION.
9. WHERE NO SPECIFIC DETAILS ARE GIVEN, CONTRACTOR SHALL BU LOCAL AUTHORITY STANDARDS.
10. ALL CONCRETE PATHS IF ANY SHALL BE OF MIN. 20Mpa RC SLAIF HARDFILL WITH 10mm GAP CONSTRUCTION JOINT EVERY 1.5m. A KERBS & AT OTHER DISTURBED AREAS SHALL BE COVERED WITH TOPSOIL & GRASSED.

**BARRIER KERBS & KERB & CHANNEL**

1. ALL KERBS SHALL BE OF 20Mpa CONCRETE FROM RECOGNISED A SUPPLIER IF NOT SUPPLIED BY THE CONTRACTOR.
2. WHERE DWGS INDICATE CHANGE FROM ONE KERB TYPE TO ANOTH WORKMANSHIP SHALL APPLY TO ENSURE EXCELLENT TRANSITION EACH TYPE & TO THE SATISFACTION OF THE CLIENT'S REPRESENTATIVE.

**LINE MARKINGS & SIGNAGE:**

1. ALL LINE MARKING & SIGNAGE TO BE INSTALLED BY THE CONTRACTOR TO THE RELEVANT AUTHORITY STANDARDS.

**LEGEND**

- RL - REDUCED LEVEL
- B1 - BARRIER KERB
- B2 - KERB & CHANNEL
- B3 - ROLL - OVER KERB
- SD - SPOON DRAIN
- UP - CONCRETE UPSTAND
- CES - CONCRETE EDGE STRIP
- SM2 - SEMI MOUNTABLE KERBS

**STP SITE ROAD SETOUT TABLE**

Pt. No.	EASTING	NORTHING
P1	109409.054	102560.116
P2	109453.949	102574.027
P3	109409.711	102554.619
P4	109410.677	102554.881
P5	109415.939	102556.311
P6	109437.811	102562.251
P7	109380.503	102515.088
P8	109418.328	102526.809
P9	109424.489	102528.718
P10	109446.124	102535.422
P11	109384.734	102457.511
P12	109397.152	102461.359
P13	109439.989	102484.182
P14	109448.143	102457.868
P15	109486.281	102469.686
P16	109395.271	102423.506
P17	109407.689	102427.354
P18	109456.297	102431.554
P19	109467.413	102385.297
P20	109508.487	102398.024
P21	109508.931	102396.591
P22	109523.020	102400.957
P23	109432.478	102347.356
P24	109470.303	102359.077
P25	109516.153	102373.285
P26	109515.413	102375.673
P27	109529.502	102380.038

<p>PROJECT: PORT MORESBY SEWERAGE SYSTEM UPGRADING PROJECT (POMSSUP)</p>		<p>TITLE: Kila Kila STP - SITE ROADS, ROAD FURNITURE, LINE MARKING &amp; CAR PARKING LAYOUT PLAN.</p>																
<p>INDEPENDENT PUBLIC BUSINESS CORPORATION PORT MORESBY SEWERAGE SYSTEM UPGRADING PROJECT PROJECT MANAGEMENT UNIT (PMU)</p> <p>JAPAN INTERNATIONAL COOPERATION AGENCY</p>	<p>CONSULTANTS:</p> <p>NJS CONSULTANTS CO., LTD. - JAPAN</p>	<p>NOTES:</p>	<table border="1" style="width: 100%; border-collapse: collapse;"> <thead> <tr> <th colspan="3">REVISIONS</th> </tr> <tr> <th>REV.</th> <th>DATE</th> <th>DESCRIPTION</th> </tr> </thead> <tbody> <tr><td> </td><td> </td><td> </td></tr> <tr><td> </td><td> </td><td> </td></tr> <tr><td> </td><td> </td><td> </td></tr> </tbody> </table>	REVISIONS			REV.	DATE	DESCRIPTION									
REVISIONS																		
REV.	DATE	DESCRIPTION																
<p>APPROVED by PMU: <span style="float: right;">Project Director Lot G.Zauya</span></p>		<p>DATE: 1. Dec 2011</p> <p>SCALE: AS SHOWN</p>																
<p>CHECKED by CONSULTANT: <span style="float: right;">Project Manager T.Fuji</span></p>		<p>DATE: 1. Dec 2011</p> <p>DRAWING NO.: STP-YW-C007</p>																

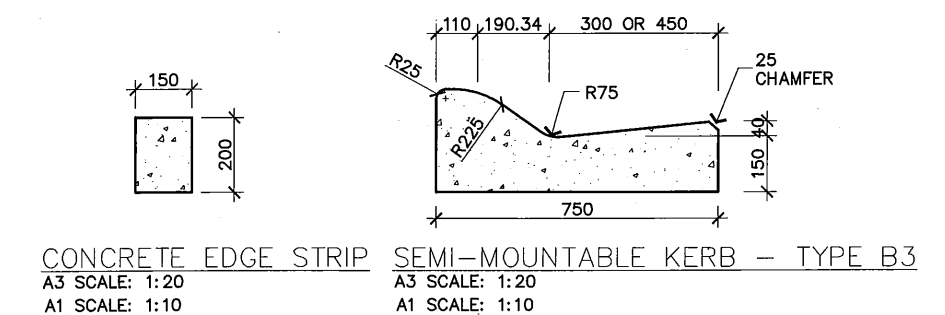
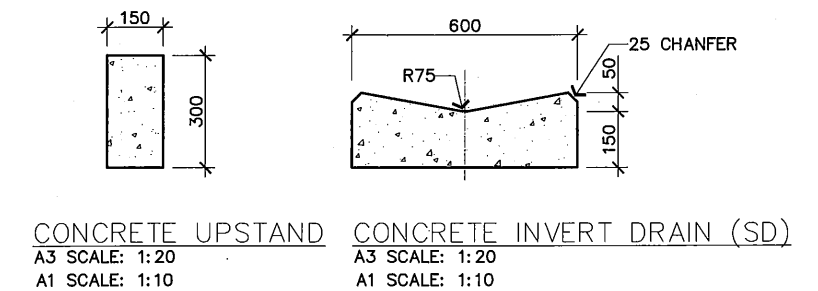
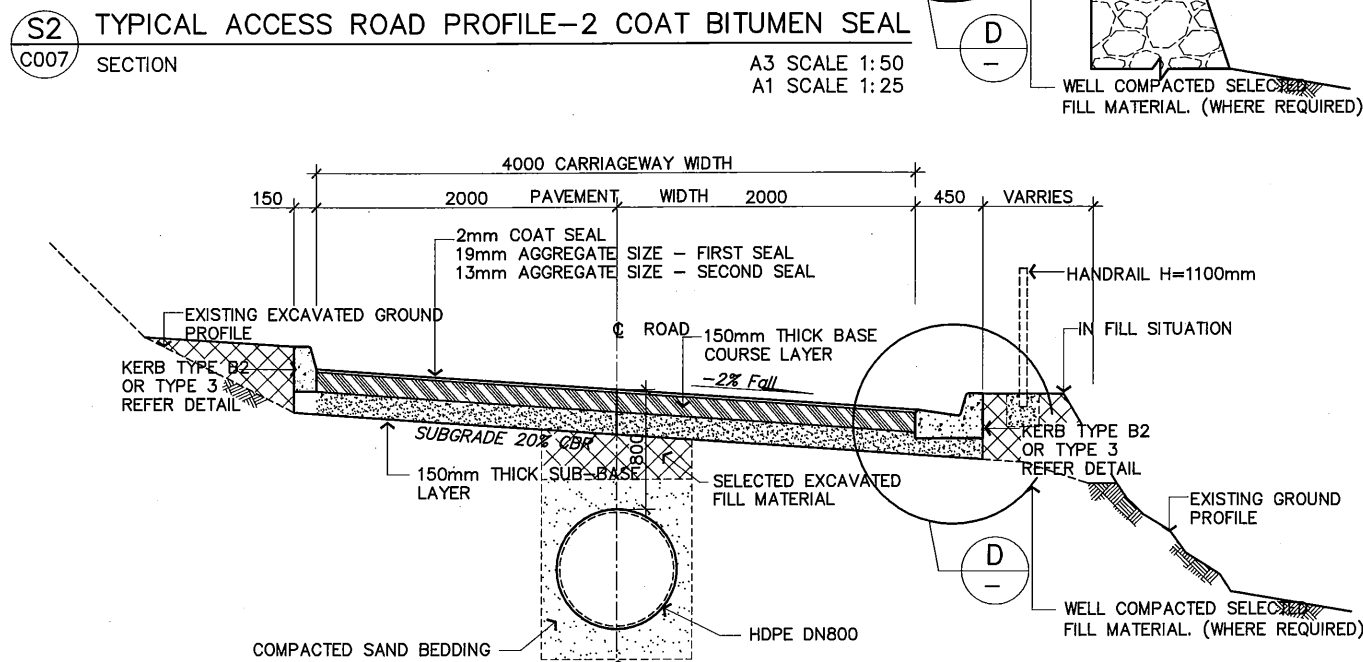
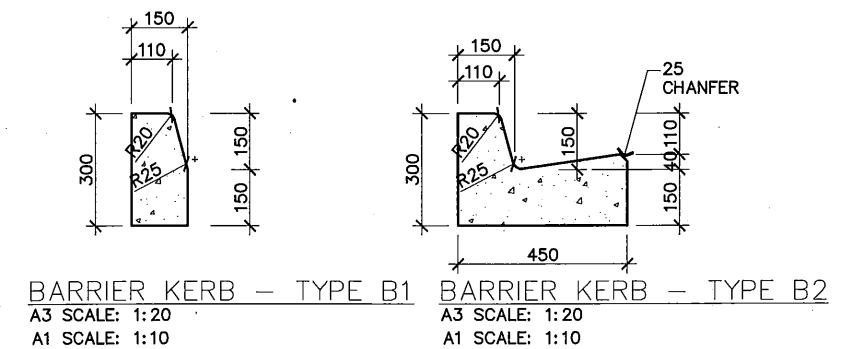
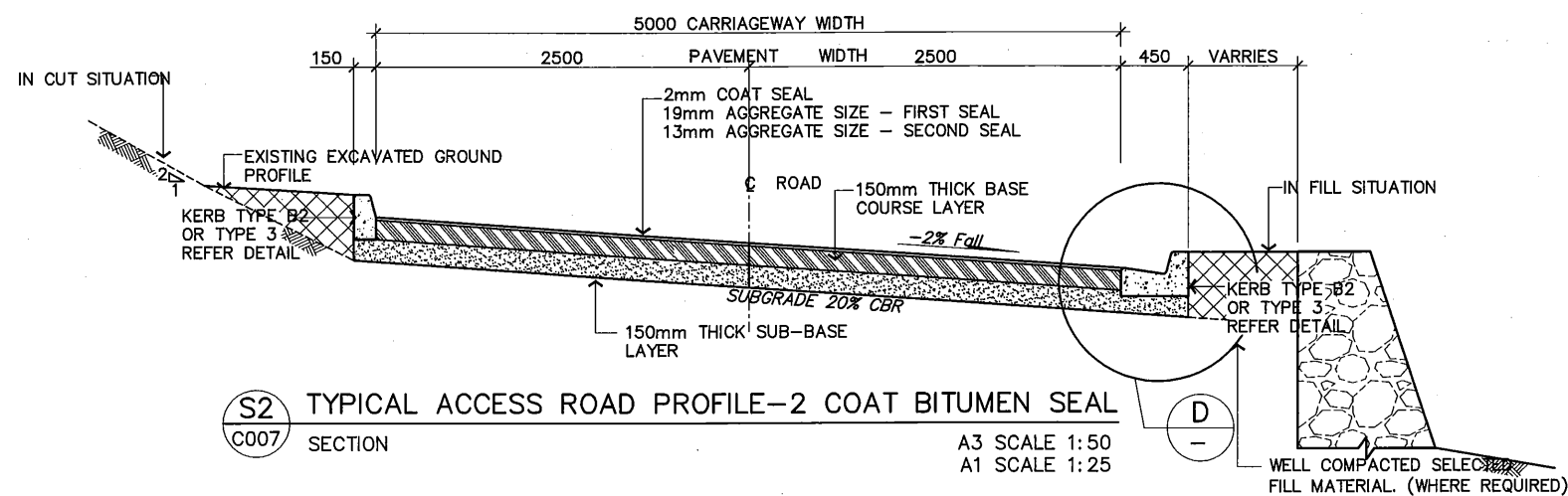
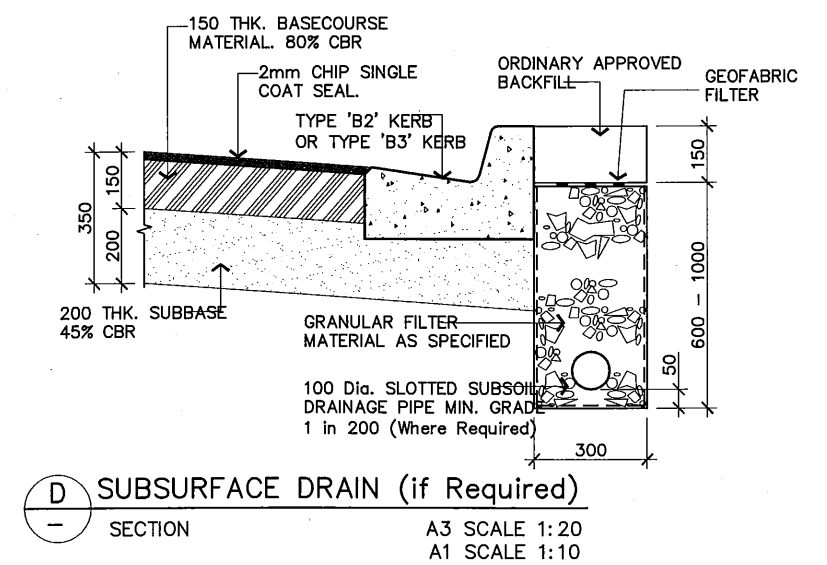
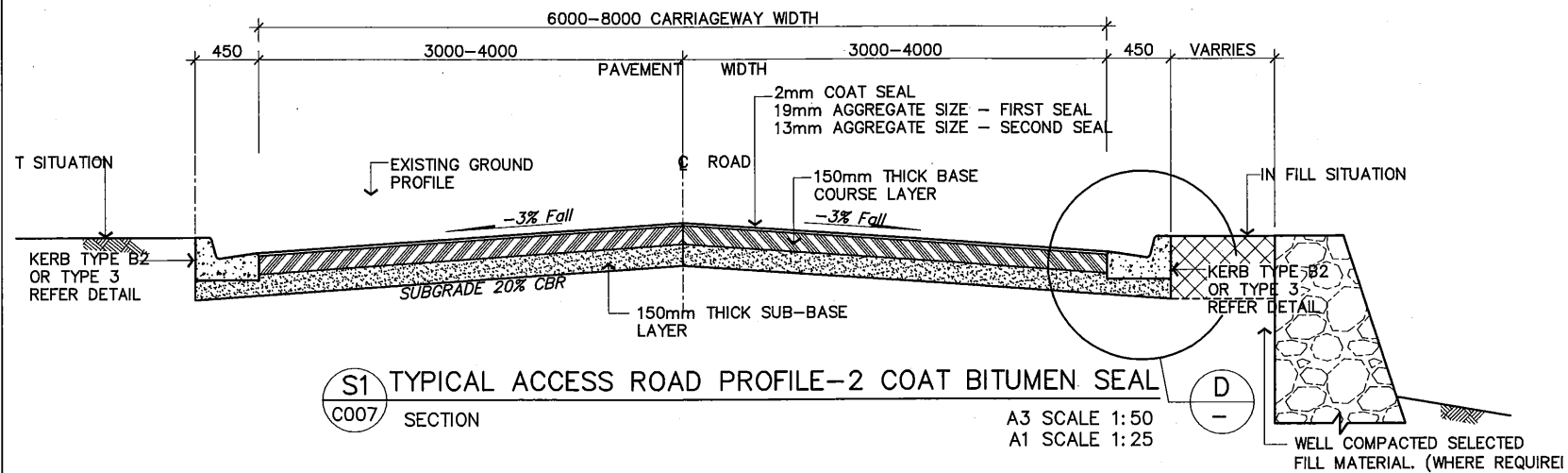

PROJECT: PORT MORESBY SEWERAGE SYSTEM UPGRADING PROJECT (POMSSUP)

TITLE: Kila Kila STP - TYPICAL PAVEMENT SECTIONS & DETAILS.

**IPBC** INDEPENDENT PUBLIC BUSINESS CORPORATION  
 PORT MORESBY SEWERAGE SYSTEM UPGRADING PROJECT  
 PROJECT MANAGEMENT UNIT (PMU)

**JICA** JAPAN INTERNATIONAL COOPERATION AGENCY

CONSULTANTS:  
**NJS CONSULTANTS CO., LTD. - JAPAN**

NOTES:

REVISIONS		
REV.	DATE	DESCRIPTION

APPROVED by PMU:	Project Director Lot G.Zauya	DATE: 1. Dec 2011	SCALE: AS SHOWN
CHECKED by CONSULTANT:	Project Manager T.Fuji	DATE: 1. Dec 2011	DRAWING NO.: STP-YW-C008

① SEPARATION LINE

To separate opposing traffic movements. Overtaking or right turning movements may be made across it in both directions. On multi lane roads, the line segment to gap proportions may be reversed to distinguish the separation line from lane lines.

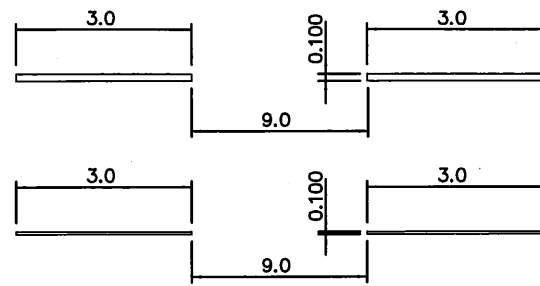

② LANE LINES

To indicate the portion of the road assigned to a single file of vehicles moving in one direction. Overtaking and right turning movements may be made across it.

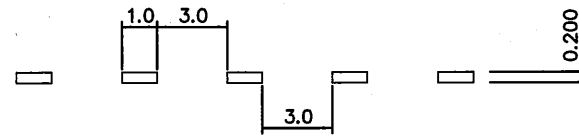

③ CONTINUITY LINE

To indicate the edge of that portion of a carriageway assigned to through traffic, and which is intended to be crossed by traffic turning at an intersection, or entering or leaving an auxiliary lane at its start or finish.



④ LANE LINES

To separate lanes of traffic moving in the same direction, where lane changing is prohibited.



⑤ TRANSITION LINES

To deflect vehicles laterally at points at which :-  
(a) the width of the carriageway changes to a greater or lesser number of lanes ; or  
(b) traffic has to negotiate median traffic islands, safety zones or obstructions on the road.

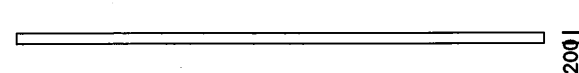

⑥ EDGE LINES

To delineate the outer edge of the travelled way.



⑦ ONE WAY BARRIER LINE

To take the place of a single separation line where overtaking is permitted in one direction only.

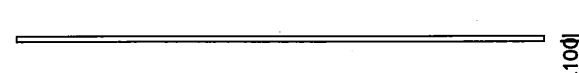

⑧ TWO WAY BARRIER LINE

To take the place of single separation line where overtaking is not permitted in either direction.

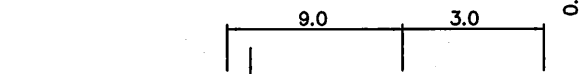

⑨ STOP LINES

To indicate the point behind which vehicles are legally required to stop.

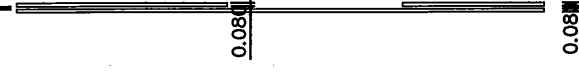

⑩ HOLDING LINES

To indicate the safe position for a vehicle to be held at a "give way" sign.

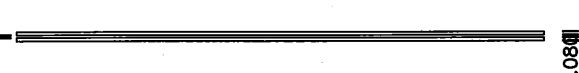

⑪ PEDESTRIAN CROSSING

To indicate a full time pedestrian priority crossing. The bars are placed parallel with the centerline of the road.

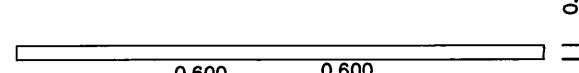

⑫ CROSSWALK MARKINGS

To be used in conjunction with mid-block or intersection signals to define pedestrian crossing.

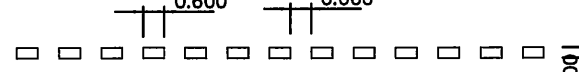

⑬ PART TIME PEDESTRIAN CROSSING MARKINGS

To indicate crossings which operate only part time e.g. school crossing.

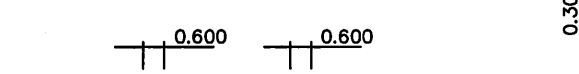

⑭ TURN LINES

To indicate the proper course to be followed by turning vehicles at major or complex intersections.

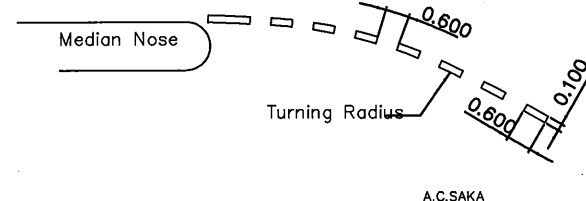
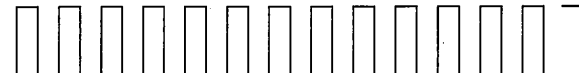

A Note "D" added. Note to pavement arrows added 14-8-79.  
B Alterations to widths and lengths for 1,2,3,7,8,12,14,... 26-8-83.

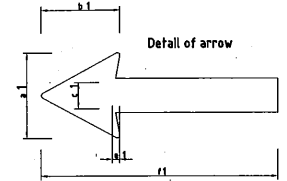
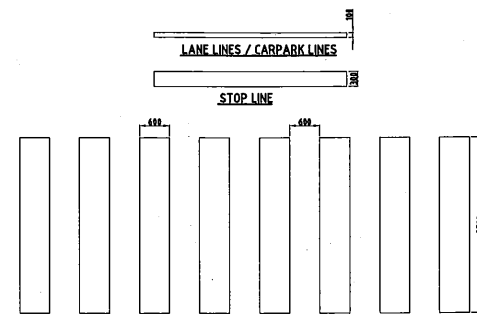

Code	a	b	c	d	e	f	g	h	i	j	k	l	m	n	o	p	q	r	s	t	u	v	w	x	y	z
RS-2A (L or R)	120	110	25	14	11	320	6																			
RS-2B (L or R)	140	147	47	42	15	420	9																			

Black letter, arrow and border on white reflectorized ground

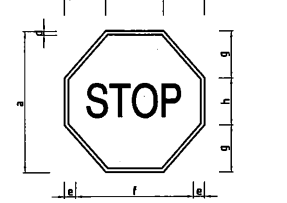
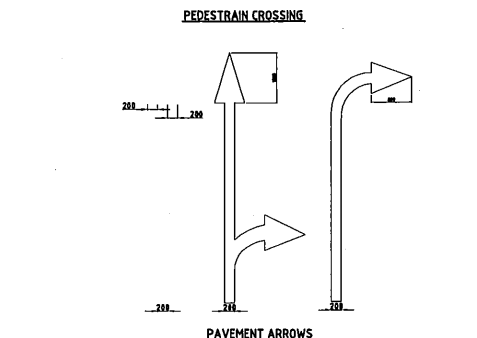

Code	a	b	c	d	e	f	g	h	i	j	k	l	m	n	o	p	q	r	s	t	u	v	w	x	y	z
RS-1A (R)	450	750																								
RS-1B (L)	476	720																								
RS-1C (L)	248	310																								
RS-1D (L)	47	53																								
RS-1E (L)	506	632																								
RS-1F (L)	200	250																								
RS-1G (L)	120	150																								

White reflectorized letters and border on red reflectorized ground

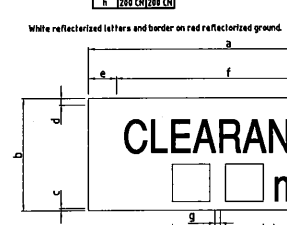
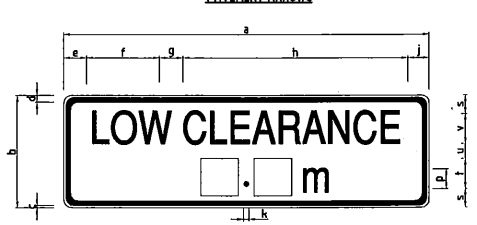

Code	a	b	c	d	e	f	g	h	i	j	k	l	m	n	o	p	q	r	s	t	u	v	w	x	y	z
RS-11	1920	640	12	36	127	287	127	1200	110	28																
RS-12	650	600	12	36	150	1200	28	84	54	140																

Code	a	b	c	d	e	f	g	h	i	j	k	l	m	n	o	p	q	r	s	t	u	v	w	x	y	z
RS-13	180	140	60	40	1600																					
RS-14	180	140	60	40	1600																					

Black letters, numerals and border on white reflectorized ground

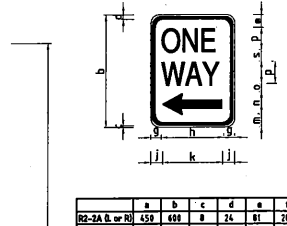
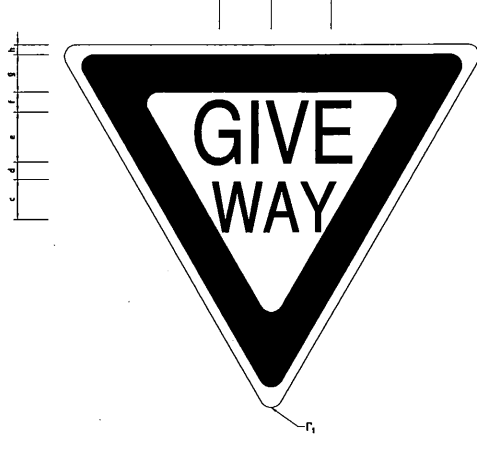
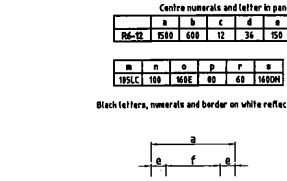
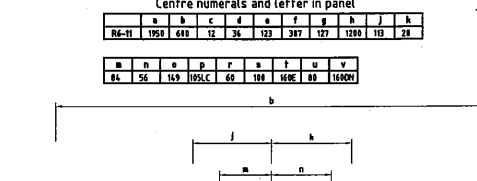

Code	a	b	c	d	e	f	g	h	i	j	k	l	m	n	o	p	q	r	s	t	u	v	w	x	y	z
RS-2A (L or R)	450	450	8	24	81	288	55	316	85	233	48	118	45	113	40	55	60	60	60	60	60	60	60	60	60	60
RS-2B (L or R)	450	450	10	30	108	396	77	416	99	270	60	144	54	135	48	66	72	72	72	72	72	72	72	72	72	72

Black letters on white reflectorized ground with red reflectorized border and white reflectorized edge strip

**NOTES**  
1. PAVEMENT MARKING COLOUR SHALL BE WHITE.  
2. MINIMUM LENGTH OF PAVEMENT ARROWS SHALL BE 5m.

**A. COLOUR:**  
The colour of the pavement marking shall be white for the alternative uses of yellow below.  
(i) The unbroken portion of barrier lines, and  
(ii) Parking lines to indicate areas whose use is Where yellow is used, the colour shall be Gold colour No. 356 in A.S. 2700, colours for spec

**B. REFLECTORS:**  
Self cleansing reflective pavement markers should be used in conjunction with painted pavement markings. Reflectors should be spaced at intervals of 10m in lit areas, and 24m intervals in unlit areas.

**C. MESSAGES ON PAVEMENTS:** conform to section 4.5.2. of A.S.1742 part 2

**D. PAVEMENT MARKING PAINTS:** conform to Specification Group 8, Road Furniture and Markings.

STANDARD DRAWING  
PAVEMENT MARKINGS

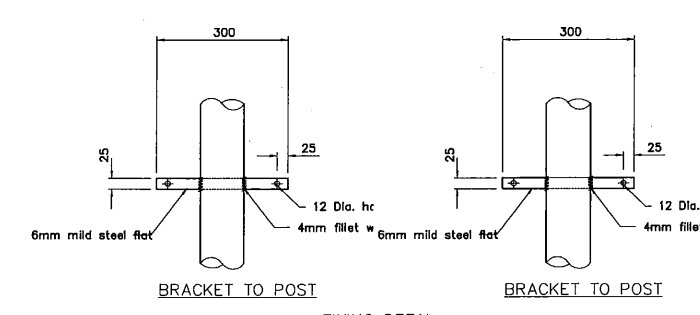
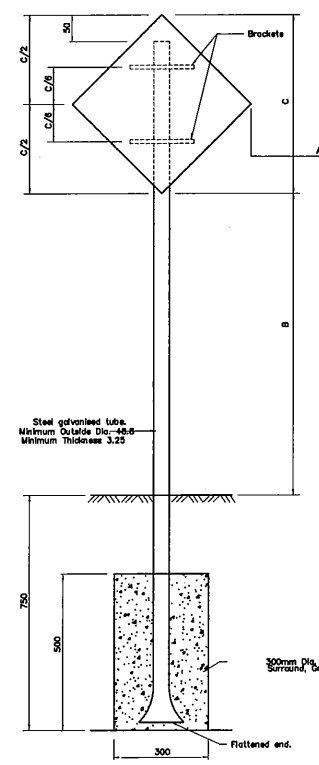

PROJECT: PORT MORESBY SEWERAGE SYSTEM UPGRADING PROJECT (POMSSUP)

TITLE: Kila Kila STP - LINE MARKING & ROAD FURNITURE DETAILS.

CONSULTANTS: NJS CONSULTANTS CO., LTD. - JAPAN

INDEPENDENT PUBLIC BUSINESS CORPORATION  
PORT MORESBY SEWERAGE SYSTEM UPGRADING PROJECT  
PROJECT MANAGEMENT UNIT (PMU)  
JICA JAPAN INTERNATIONAL COOPERATION AGENCY

REVISIONS:

REV.	DATE	DESCRIPTION

APPROVED by PMU: Project Director Lot G.Zauya  
CHECKED by CONSULTANT: Project Manager T.Fuji

DATE: 1. Dec 2011  
SCALE: AS SHOWN  
DRAWING NO.: STP-YW-C009

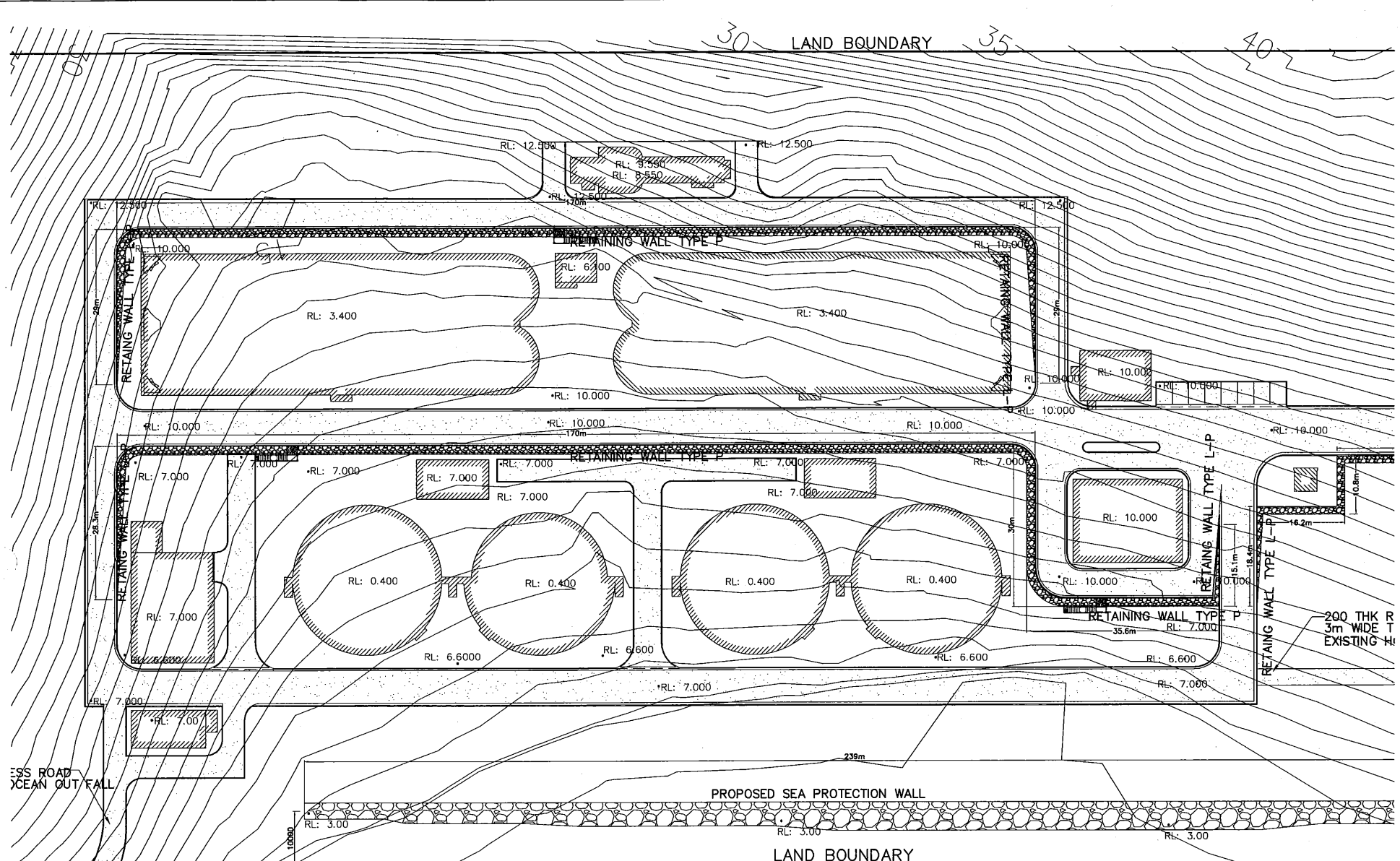

**P5 EARTH RETAINING (WALL) LAYOUT & DETAILS**  
 PLAN  
 A1 SCALE 1:500  
 A3 SCALE 1:1000

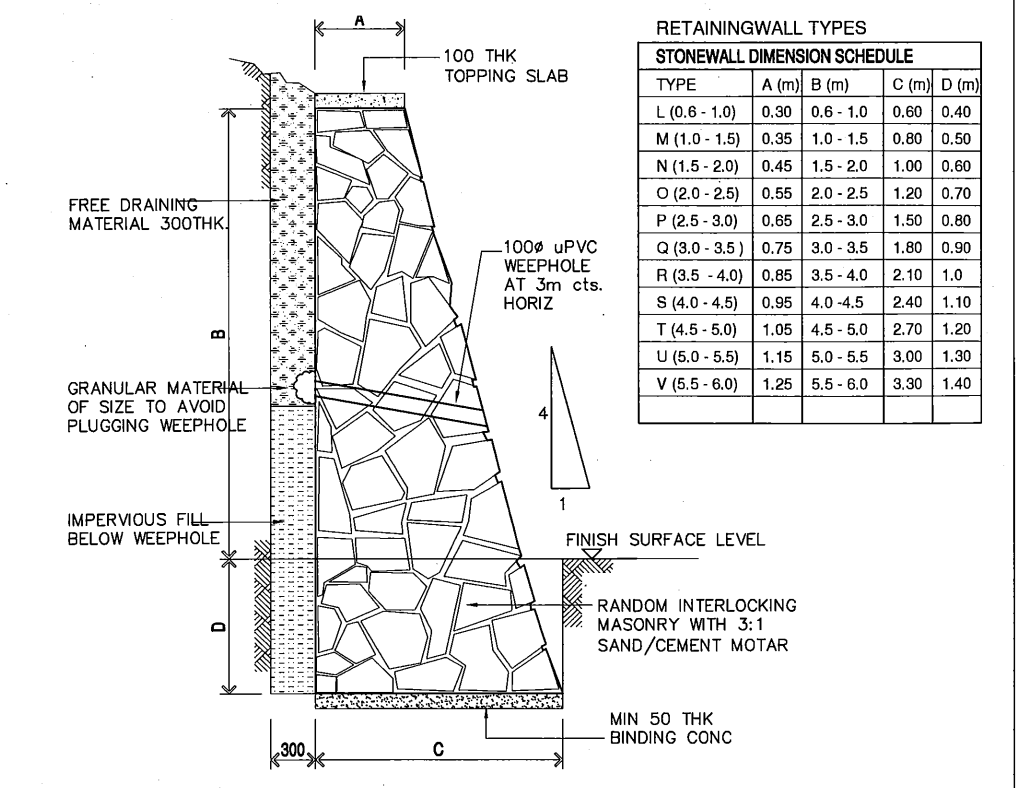

RETAININGWALL TYPES				
STONEWALL DIMENSION SCHEDULE				
TYPE	A (m)	B (m)	C (m)	D (m)
L (0.6 - 1.0)	0.30	0.6 - 1.0	0.60	0.40
M (1.0 - 1.5)	0.35	1.0 - 1.5	0.80	0.50
N (1.5 - 2.0)	0.45	1.5 - 2.0	1.00	0.60
O (2.0 - 2.5)	0.55	2.0 - 2.5	1.20	0.70
P (2.5 - 3.0)	0.65	2.5 - 3.0	1.50	0.80
Q (3.0 - 3.5)	0.75	3.0 - 3.5	1.80	0.90
R (3.5 - 4.0)	0.85	3.5 - 4.0	2.10	1.0
S (4.0 - 4.5)	0.95	4.0 - 4.5	2.40	1.10
T (4.5 - 5.0)	1.05	4.5 - 5.0	2.70	1.20
U (5.0 - 5.5)	1.15	5.0 - 5.5	3.00	1.30
V (5.5 - 6.0)	1.25	5.5 - 6.0	3.30	1.40

**TYPICAL STONE PITCH RETAINING WALL**  
 SECTION  
 SCALE 1:25

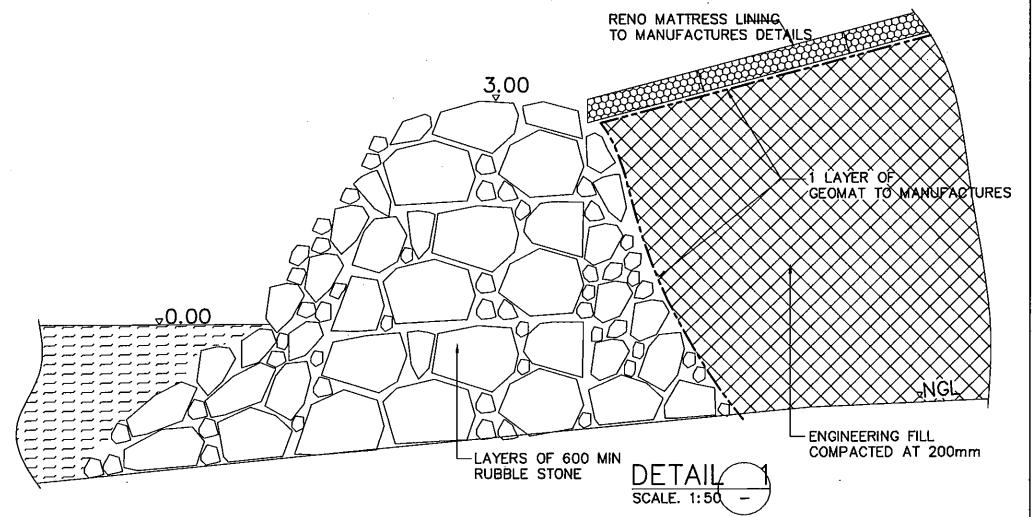

**DETAIL**  
 SCALE 1:50

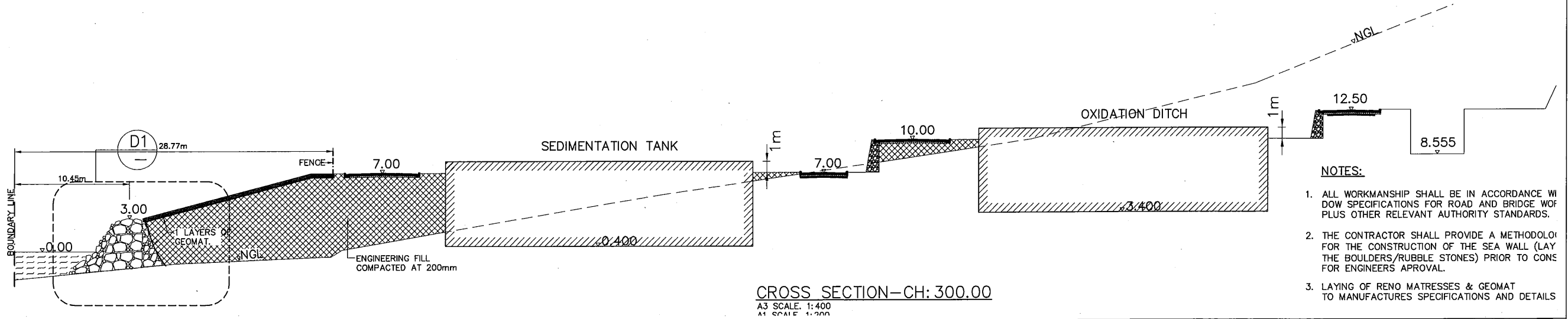





**CROSS SECTION-CH: 300.00**  
 A3 SCALE 1:400  
 A1 SCALE 1:200

- NOTES:**
- ALL WORKMANSHIP SHALL BE IN ACCORDANCE WITH SPECIFICATIONS FOR ROAD AND BRIDGE WORK PLUS OTHER RELEVANT AUTHORITY STANDARDS.
  - THE CONTRACTOR SHALL PROVIDE A METHODOLOGY FOR THE CONSTRUCTION OF THE SEA WALL (LAY THE BOULDERS/RUBBLE STONES) PRIOR TO CONE FOR ENGINEERS APPROVAL.
  - LAYING OF RENO MATTRESSES & GEOMAT TO MANUFACTURES SPECIFICATIONS AND DETAILS

PROJECT: PORT MORESBY SEWERAGE SYSTEM UPGRADING PROJECT (POMSSUP)		TITLE: Kila Kila STP - EARTH RETAINING (WALL) LAYOUT PLAN, SECTIONS & DETAILS.																
INDEPENDENT PUBLIC BUSINESS CORPORATION PORT MORESBY SEWERAGE SYSTEM UPGRADING PROJECT PROJECT MANAGEMENT UNIT (PMU)		CONSULTANTS: NJS CONSULTANTS CO., LTD. - JAPAN																
JAPAN INTERNATIONAL COOPERATION AGENCY		NOTES:	<table border="1"> <thead> <tr> <th colspan="3">REVISIONS</th> </tr> <tr> <th>REV.</th> <th>DATE</th> <th>DESCRIPTION</th> </tr> </thead> <tbody> <tr> <td> </td> <td> </td> <td> </td> </tr> <tr> <td> </td> <td> </td> <td> </td> </tr> <tr> <td> </td> <td> </td> <td> </td> </tr> </tbody> </table>	REVISIONS			REV.	DATE	DESCRIPTION									
REVISIONS																		
REV.	DATE	DESCRIPTION																
APPROVED by PMU: Project Director Lot G.Zauya		DATE: 1. Dec 2011	SCALE: AS SHOWN															
CHECKED by CONSULTANT: Project Manager T.Fuji		DATE: 1. Dec 2011	DRAWING NO.: STP-YW-C010															

**NOTES:**  
 1. THE SUMP LOCATION SHALL BE AS PER DOWN LOCATION TO ARCHITECT DRAWING

**LEGEND:**  
 - PROPOSED NEW BUILDING  
 - STORMWATER PIT. REFER TO DETAILS  
 - STORMWATER PIPE  
 - STORMWATER PIPE UNDER ROAD WITH CONCRETE ENCASEMENT  
 ← fall - FALL  
 → flow - FLOW

**STORMWATER PITS LEVEL**

PIT No.	INVERT LEVEL (m)	TOP LEVEL (m)
SP1	11.450	12.450
SP2	10.927	11.870
SP3	10.403	11.290
SP4	10.015	11.015
SP5	8.920	9.920
SP6	8.893	9.920
SP6a	8.886	9.920
SP7	8.753	9.532
SP7a	8.746	9.532
SP8	8.613	9.144
SP8a	8.607	9.144
SP9	8.596	9.006
SP10	5.808	6.908
SP11	8.920	9.920
SP12a	8.850	9.950
SP12b	8.720	9.820
SP13	6.654	7.754
SP14	5.022	6.122
SP14a	4.951	9.920
SP15	4.760	6.654
SP15a	4.666	6.654
SP16	4.656	6.388
SP16a	4.562	6.388
SP17	4.552	6.122

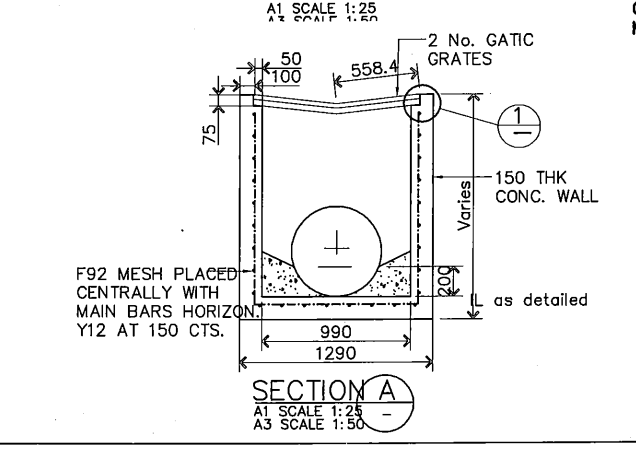
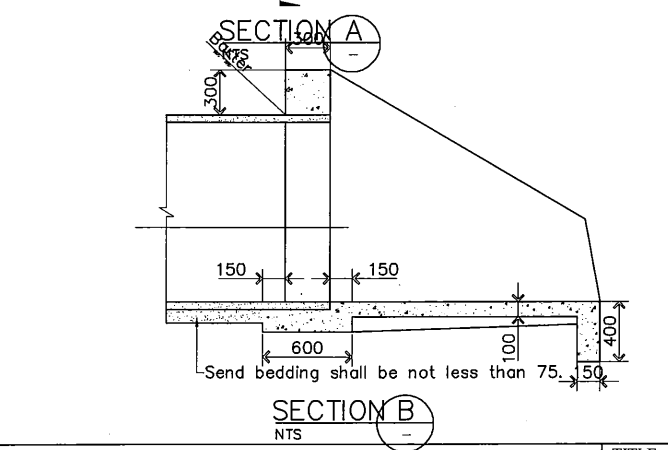
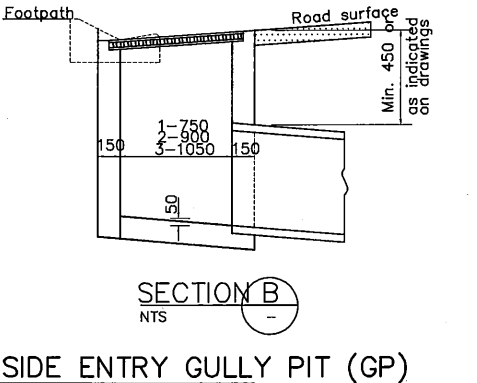
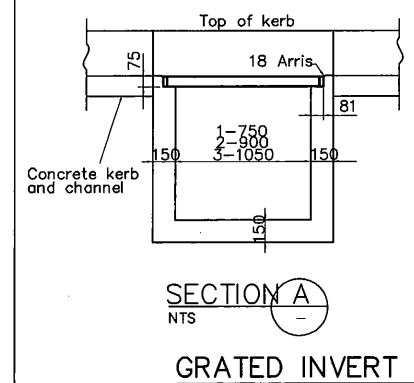
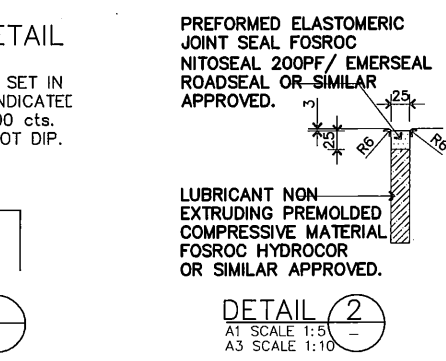
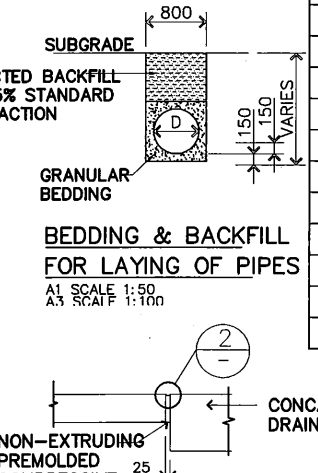
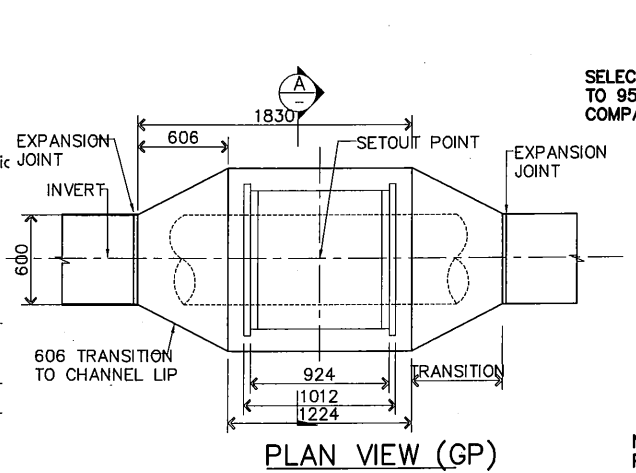
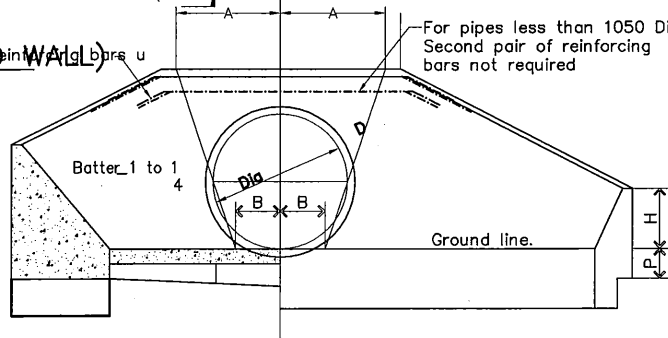
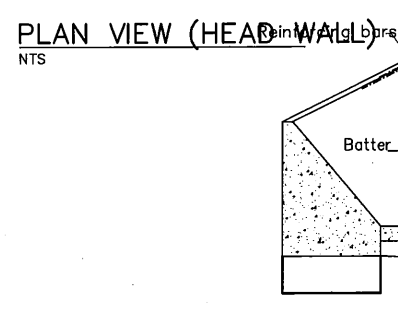
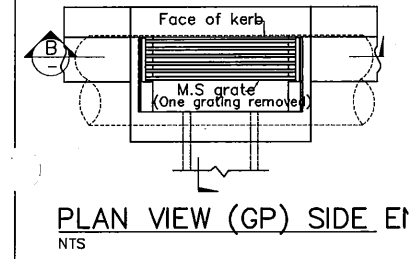
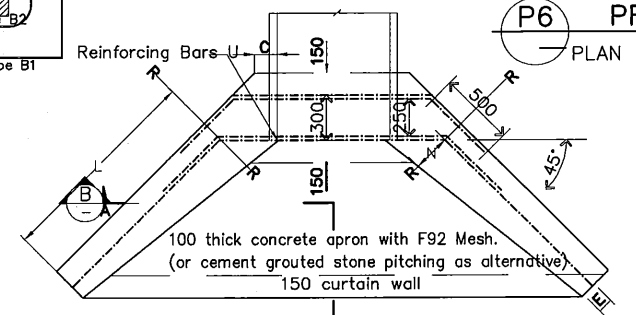
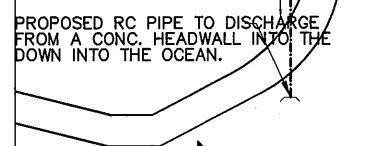
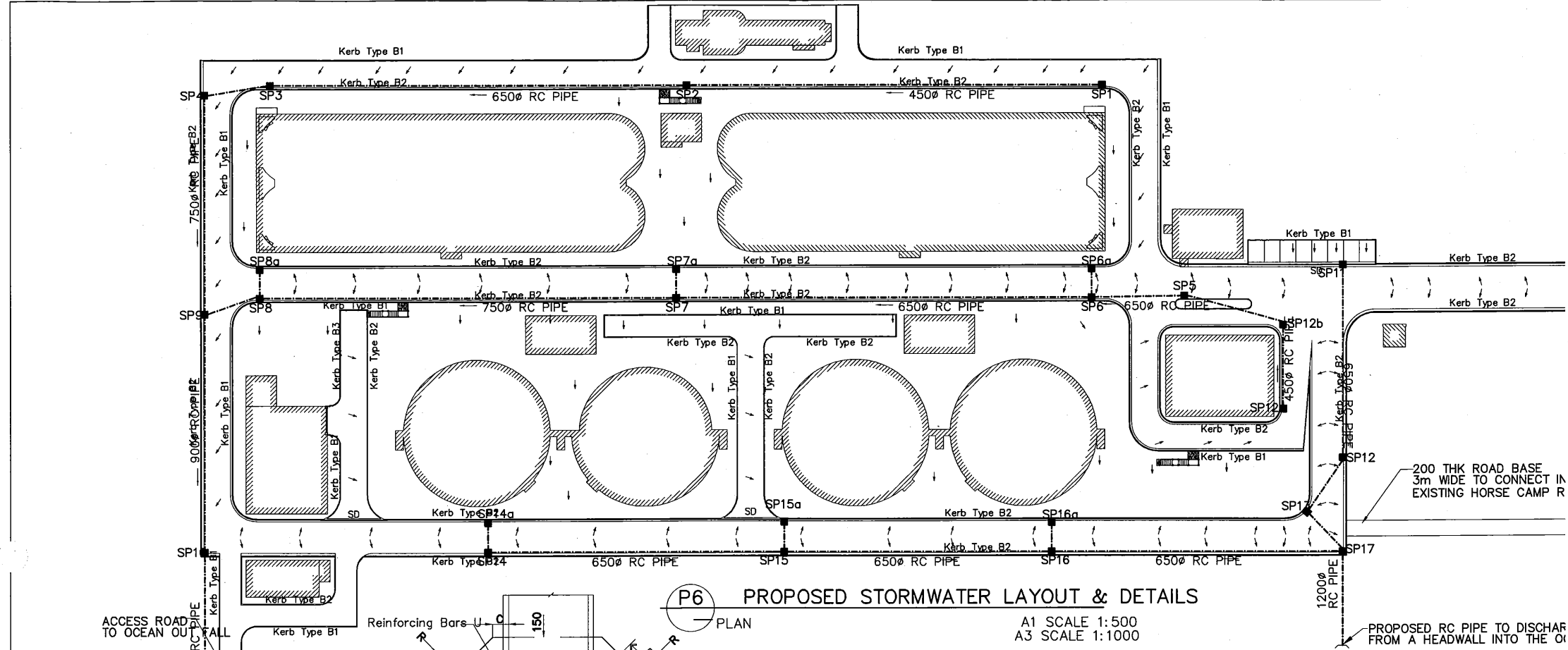

PROJECT: PORT MORESBY SEWERAGE SYSTEM UPGRADING PROJECT (POMSSUP)

CONSULTANTS: NJS CONSULTANTS CO., LTD. - JAPAN

INDEPENDENT PUBLIC BUSINESS CORPORATION  
 PORT MORESBY SEWERAGE SYSTEM UPGRADING PROJECT  
 PROJECT MANAGEMENT UNIT (PMU)  
 JICA JAPAN INTERNATIONAL COOPERATION AGENCY

TITLE: Kila Kila STP - STORMWATER (DRAINAGE) LAYOUT PLAN DETAILS.

NOTES:

REVISIONS			APPROVED by PMU:	Project Director Lot G. Zauya	DATE: 1. Dec 2011	SCALE: AS SHOWN
REV.	DATE	DESCRIPTION				

CHECKED by CONSULTANT: Project Manager T. Fuji

DATE: 1. Dec 2011  
 DRAWING NO.: STP-YW-C011

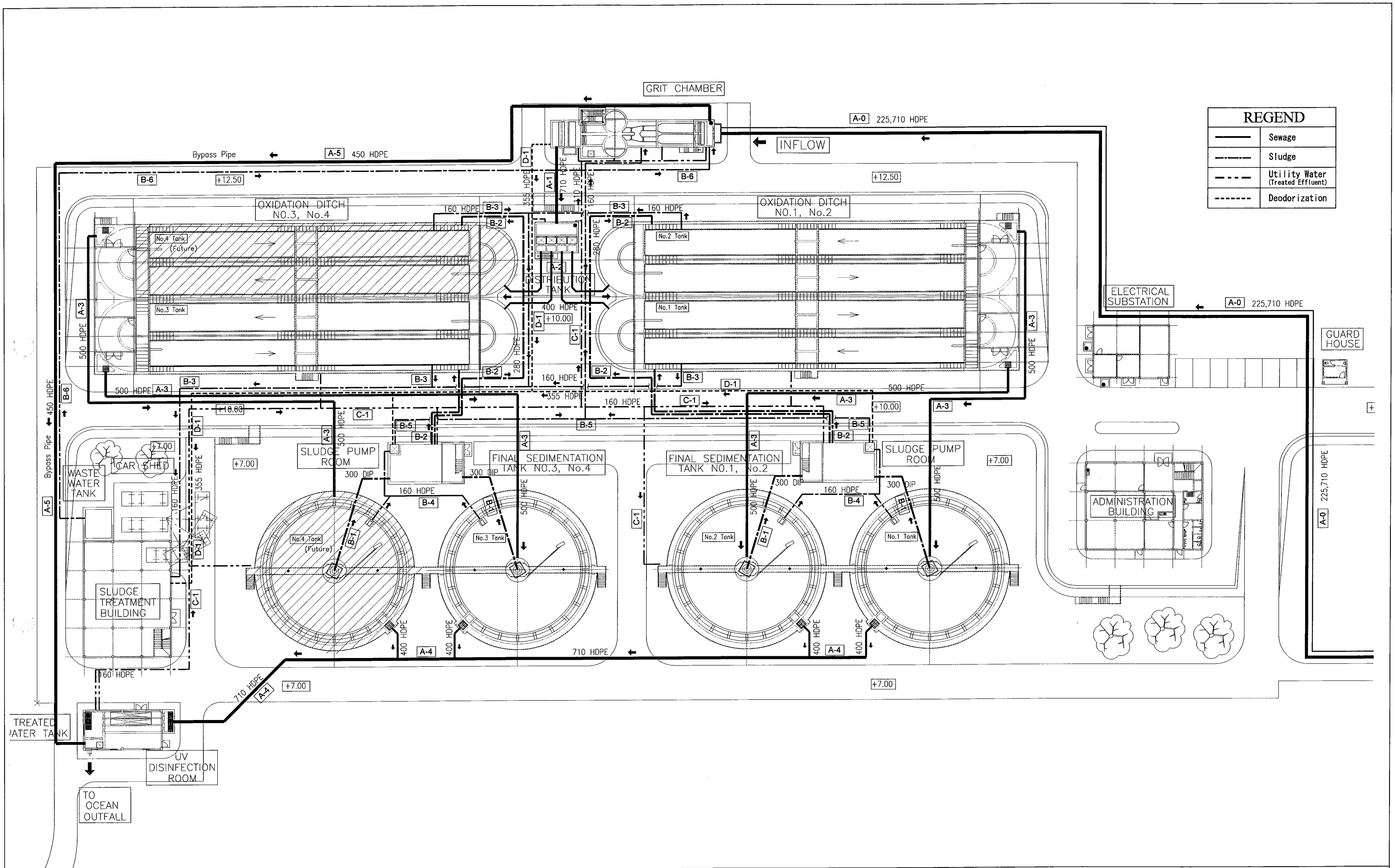

REGEND	
	Sewage
	Sludge
	Utility Water (Treated Effluent)
	Deodorization

PROJECT: PORT MORESBY SEWERAGE SYSTEM UPGRADING PROJECT (POMSSUP)

CLIENT: INDEPENDENT PUBLIC BUSINESS CORPORATION  
 PORT MORESBY SEWERAGE SYSTEM UPGRADING PROJECT  
 PROJECT MANAGEMENT UNIT (PMU)  
 JAPAN INTERNATIONAL COOPERATION AGENCY

CONSULTANTS: NJS CONSULTANTS CO., LTD. - JAPAN

TITLE: Kila Kila STP - PROCESS PIPEWORK LAYOUT PLAN

NOTES:

REVISIONS		
REV.	DATE	DESCRIPTION

APPROVED by PMU:  
Project Director  
Lot G. Zauya

CHECKED by CONSULTANT  
Project Manager  
T. Fuji

DATE: 1. Dec 2011

SCALE: 1/600

DATE: 1. Dec 2011

DRAWING NO.: STP-YW-012

## Specifications of Process Pipeline

Category	No.	Diameter (DN) (mm)	Material	Total Length (m)	Nos. of Line	Bottom Level of Pipe (BOP)		Description	
						from	to		
Sewage	A-0	225,710	HDPE	770.0	2	from	From Kaugere and Horsecamp PS	L=385×2=700	
						to	+10.00	Grit Chamber	
	A-1	710	HDPE	13.5	1	from	+10.55	Grit Chamber	
						to	+8.40	Distribution Tank	
	A-2	400	HDPE	62.0	4	from	+8.40	Distribution Tank	L=Ave. 15.5×4=62.0
						to	+8.30	Oxidation Ditch	
Sludge	A-3	500	HDPE	345.5	4	from	+5.80	Oxidation Ditch	L=Ave. 89.5×4-12.5(Future)=345.5
						to	+3.00	Final Sedimentation Tank	
	A-4	400, 710	HDPE	148.2	1	from	+5.50	Final Sedimentation Tank	L=5.8×4(dia400)+125(dia710)=148.2
						to	+5.00	UV Disinfection Room	
	A-5	450	HDPE	231.8	1	from	+11.80	Grit Chamber	Bypass pipe for emergency
						to	+5.40	Treatedwater Tank	
Sludge	B-1	300	DIP	74.3	4	from	-	Final Sedimentation Tank	L=21.7×4-12.5(Future)=74.3
						to	-	Sludge Pump Room	
	B-2	280	HDPE	222.0	4	from	-	Sludge Pump Room	(Return Sludge)
						to	-	Oxidation Ditch	L=Ave. 55.5×4=222.0
	B-3	160	HDPE	208.4	4	from	-	Oxidation Ditch	(Withdrawn Sludge)
						to	-	Sludge Treatment Building	L=Ave. 52.1×4=208.4
Utility TE* Water (*Treated Effluent)	B-4	160	HDPE	65.2	4	from	-	Scum Collector	L=Ave. 16.3×4=65.2
						to	-	Scum Pit	
	B-5	160	HDPE	147.8	2	from	-	Scum Pit	L=Ave. 73.9×2=147.8
						to	-	Scum Screen (Grit Chamber)	
	B-6	225	HDPE	181.0	1	from	-	Wastewater Tank	
						to	-	Grit Chamber	
Deodorization	D-1	355	HDPE	222.2	1	from	-	Grit Chamber, Distribution Tank, Scum Pit	L=151.5(dia110)+171.7(dia160)=323.2
						to	-	Sludge Treatment Building	

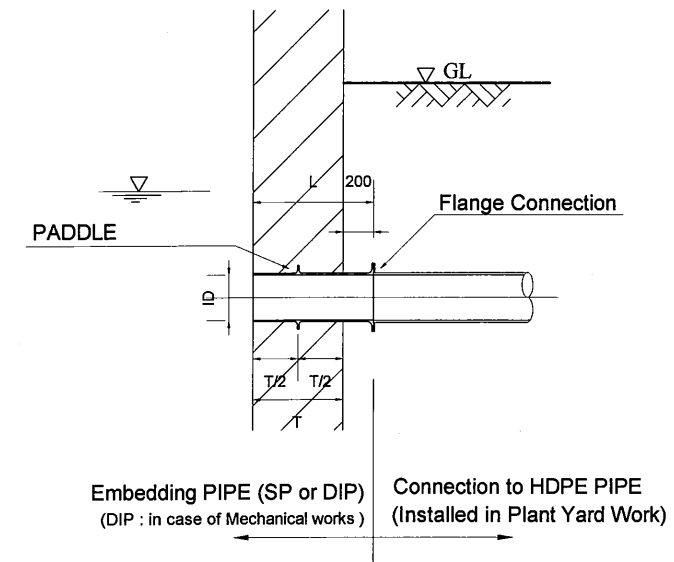

**Typical Details of Pipework Connection**

### Notes

1. Pipe diameter indicate a Nominal Diameter (DN).
2. Sludge, Utility TE water and Deodorization pipes shall be coordinated with mechanical works
3. Refer to Standard Specification [Section 11000 General Requirements 1.15-3-(4)] for Piping pass through the wall
4. Minimum earth cover of pipes shall be more than 600mm.

PROJECT: PORT MORESBY SEWERAGE SYSTEM UPGRADING PROJECT (POMSSUP)

TITLE: Kila Kila STP - PROCESS PIPEWORK DETAILS

CLIENT: **IPBC** INDEPENDENT PUBLIC BUSINESS CORPORATION  
 PORT MORESBY SEWERAGE SYSTEM UPGRADING PROJECT  
 PROJECT MANAGEMENT UNIT (PMU)  
 JAPAN INTERNATIONAL COOPERATION AGENCY

CONSULTANTS: NJS CONSULTANTS CO., LTD. - JAPAN

NOTES:

REVISIONS		
REV.	DATE	DESCRIPTION

APPROVED by PMU:  
Project Director  
Lot G.Zauya

CHECKED by CONSULTANT  
Project Manager  
T.Fuji

DATE:  
1. Dec 2011

DATE:  
1. Dec 2011

SCALE:  
NON

DRAWING NO.:  
STP-YW-013

LAND BOUNDARY

**NOTES:**

1. APART FROM THAT INDICATED ON THIS PLAN FOR THE SEWERAGE LINES, ALL CONNECTION DETAILS, JOINTING DETAILS, PIPE COVER, INSTALLATION, BEDDING, ETC, SHALL BE IMPLEMENTED IN ACCORDANCE WITH THE EDA RANU STANDARDS.
2. WHERE PIPING CROSSES ROAD, CONCRETE LINING SHALL APPLY TO PROTECT PIPING FROM HEAVY LOADING. REFER TO STD. DETAILS; CONCRETE ENCASEMENT.
3. ALL SERVICES CONNECTIONS TO 150Ø uPVC MAIN SHALL BE JUMP UP CONNECTIONS TYPICAL FROM BUILDINGS TO MAIN & TO STD. DETAILS AS PER THE EDA RANU DETAILS.
4. CONCRETE ENCASEMENT SHALL 20 mPa
5. MAIN WATER LINE FROM WATER MAIN SHALL BE AS INDICATED. ALL CONNECTIONS TO HYDRANT SHALL BE 80mm DIA. uPVC, ALL CONNECTIONS TO BUILDINGS SHALL BE INSTALLED DURING CONSTRUCTION OF BUILDING AND SHALL REFER TO SERVICES ENG'S SPECIFICATIONS & STANDARD DETAILS TO FIRE DEPARTMENT.
6. ALL HYDRANT OUTLETS SHALL BE TESTED FOR ADEQUATE PRESSURE IN CONSULTATION WITH THE FIRE DEPARTMENT.
7. REFER TO BUILDING SERVICES ENGINEERS DWGS. FOR DETAILS OF FIRE HOSE REEL CONNECTION.
8. ALL VALVES TO BE CLOCKWISE CLOSING BRONZE GATE VALVE.
9. ALL VALVES TO BE IN NON TRAFFICABLE GRASS AREAS.
10. REFER TO PIPELINE DWGS. FOR DETAILS OF SEWER & WATER CONNECTION AND PIPE BEDDING.
11. REFER TO EDA RANU FOR THE VALVE PIT DETAILS & SPECIFICATIONS.

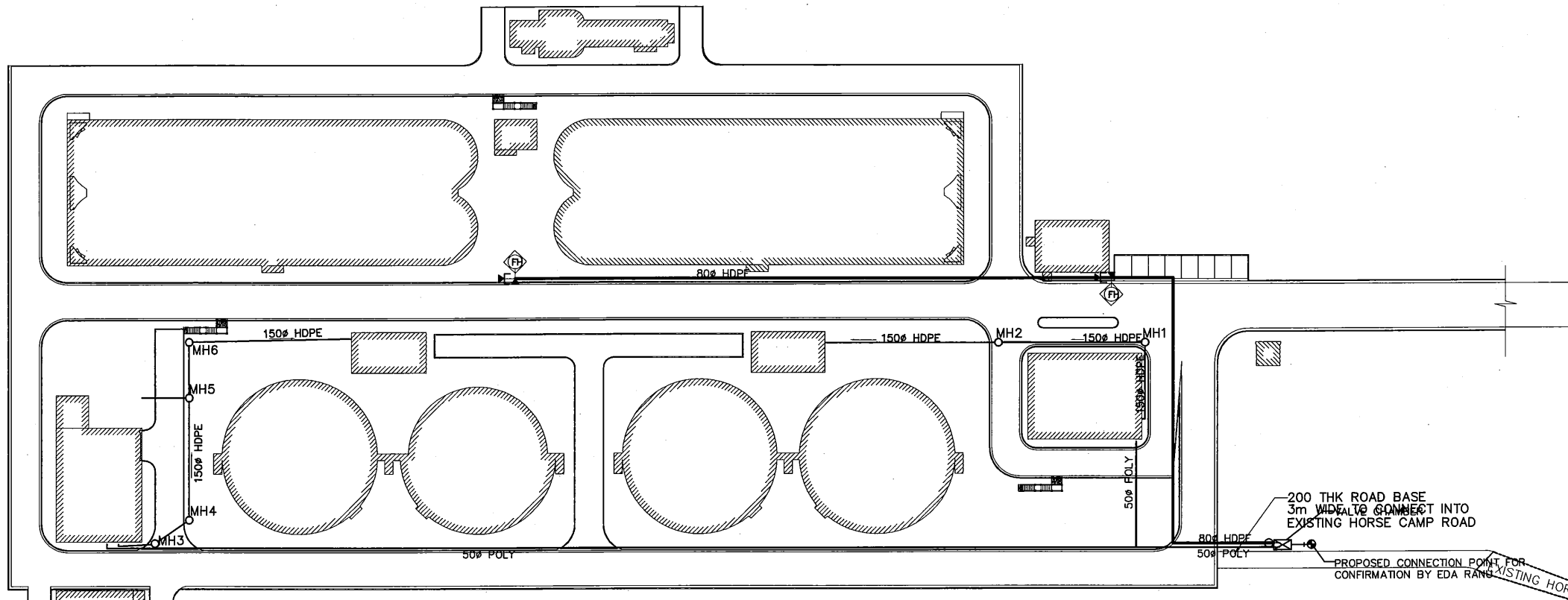

**P7 EXTERNAL SITE SERVICES LAYOUT PLAN**

PLAN A3 SCALE 1:1000  
A1 SCALE 1:500

LAND BOUNDARY

**LEGEND:**

- EXISTING BUILDING
- MANHOLE & SEWER
- INSPECTION SHAFT
- DIRECTION OF FLOW
- SEWER AND WATER LINE UNDER ROAD WITH CONCRETE ENCASEMENT
- JUC-JUMP UP CONNECTION
- FIRE HYDRANT - GROUND BALL H
- ISOLATION OR SERVICE VALVE
- THRUST BLOCK
- END CAP
- NEW WATER LINES (HDPE) TO DIAMETER AS SPECIFIED
- NEW WATER LINES (HDPE) TO DIAMETER AS SPECIFIED
- NEW WATER LINES (POLY) TO DIAMETER AS SPECIFIED
- VALVE CHAMBER

**SUMP LEVEL**

SUMP No.	INLET LEVEL (m)	OUTLET LEVEL (m)
MH1	9.334	9.294
MH2	9.169	6.450
MH3	6.370	6.330
MH4	6.298	6.258
MH5	6.154	6.360
MH6	6.070	6.114

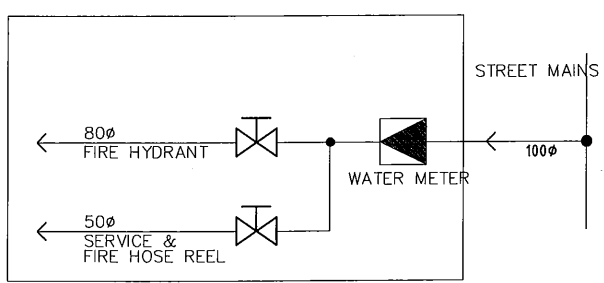
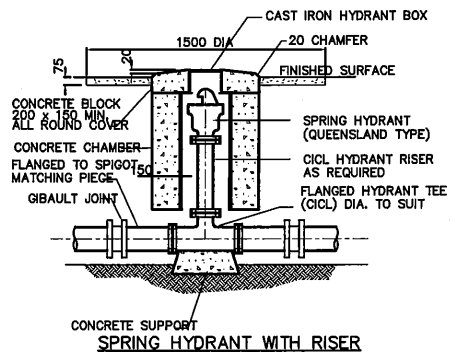
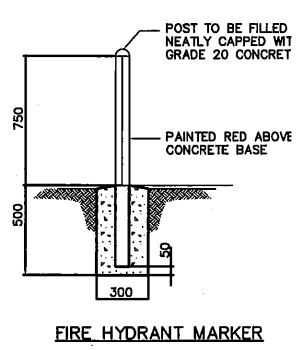

PROJECT: PORT MORESBY SEWERAGE SYSTEM UPGRADING PROJECT (POMSSUP) TITLE: Kila Kila STP - EXTERNAL SITE SERVICES LAYOUT PLAN.

INDEPENDENT PUBLIC BUSINESS CORPORATION  
PORT MORESBY SEWERAGE SYSTEM UPGRADING PROJECT  
PROJECT MANAGEMENT UNIT (PMU)  
JICA JAPAN INTERNATIONAL COOPERATION AGENCY

CONSULTANTS:  
NJS CONSULTANTS CO., LTD. - JAPAN

NOTES:

REVISIONS		
REV.	DATE	DESCRIPTION





APPROVED by PMU: Project Director Lot G.Zauya DATE: 1. Dec 2011 SCALE: AS SHOWN  
CHECKED by CONSULTANT: Project Manager T.Fuji DATE: 1. Dec 2011 DRAWING NO.: STP-YW-C012



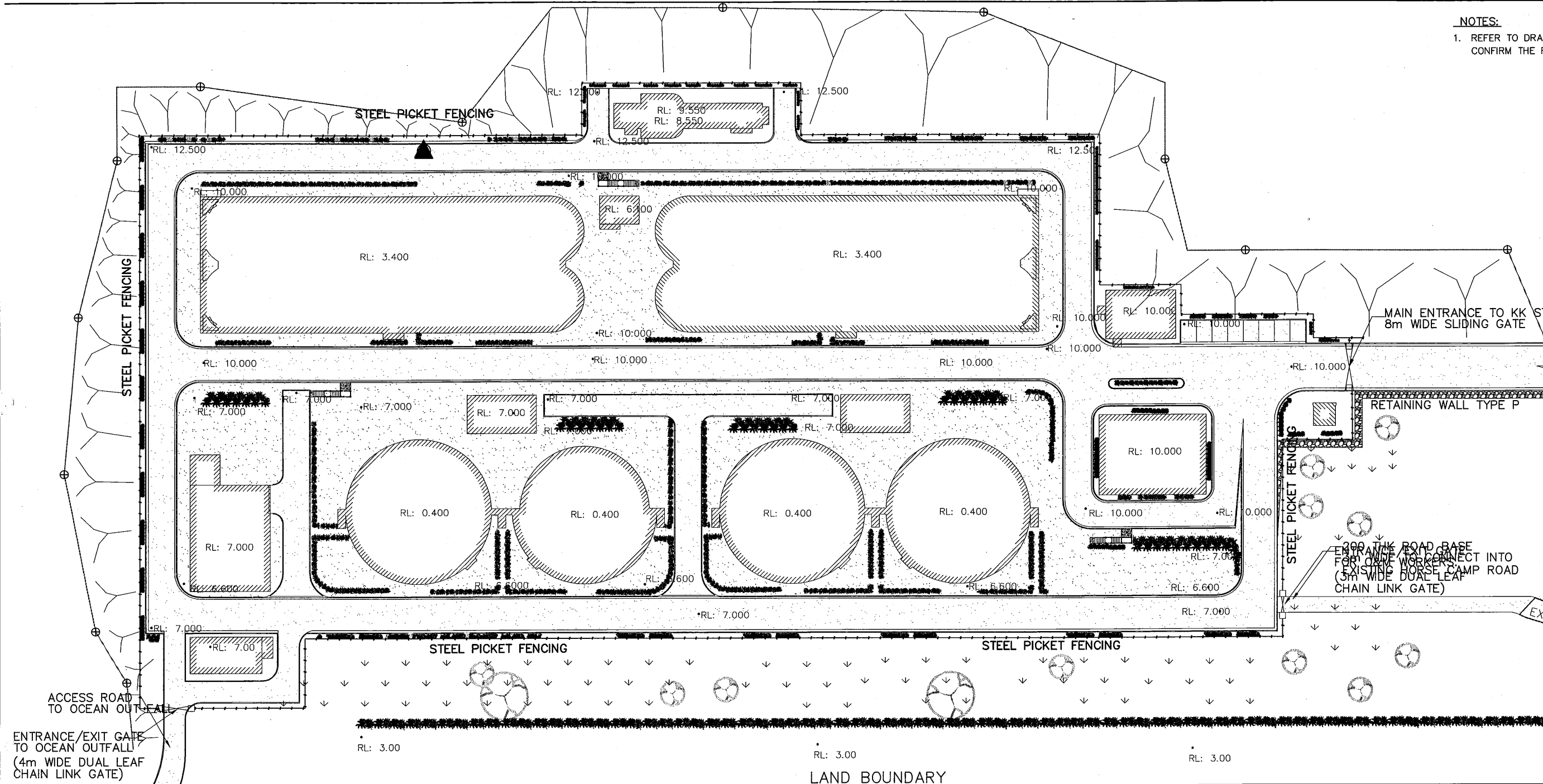

LAND BOUNDARY

**NOTES:**  
1. REFER TO DRAWING NO. STP-YW-C01  
CONFIRM THE FENCING AND GATE DE



- LEGEND**
-  PROPOSED STP SITE STRUCTURES
  -  PROPOSED LANDSCAPING A
  -  PROPOSED FENCE LINE
  -  ENTRANCE & EXIT GATES 1

**P8 LAND SCAPPING & FENCING LAYOUT PLAN**  
PLAN  
A3 SCALE 1:1000  
A1 SCALE 1:500

PROJECT: PORT MORESBY SEWERAGE SYSTEM UPGRADING PROJECT (POMSSUP)		TITLE: Kila Kila STP - LAND SCAPPING & FENCING LAYOUT PLAN.	
 INDEPENDENT PUBLIC BUSINESS CORPORATION  JAPAN INTERNATIONAL COOPERATION AGENCY	CONSULTANTS:  NJS CONSULTANTS CO., LTD. - JAPAN	NOTES:	APPROVED by PMU: Project Director Lot G.Zauya DATE: 1. Dec 2011 SCALE: AS SHOWN
			CHECKED by CONSULTANT: Project Manager T.Fuji DATE: 1. Dec 2011 DRAWING NO.: STP-YW-C015

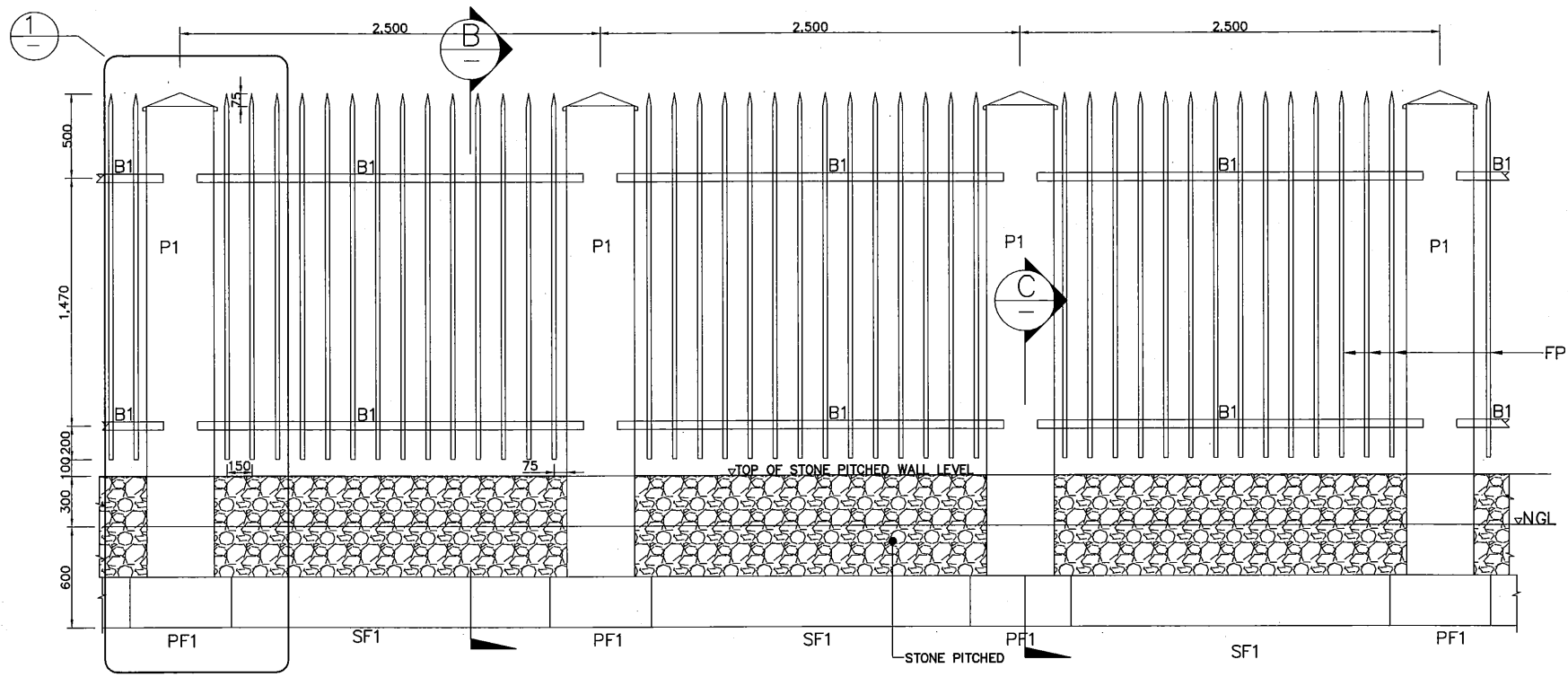

**ELEVATION STEEL PICKET FENCING**  
 A3 SCALE 1:40  
 A1 SCALE 1:20

**MEMBER SCHEDULE**

MARK	SIZE/DESCRIPTION	REINFORCEMENT		REMARK
		LENGTHWISE	WIDTHWISE	
P1	400 SQR PIER			BLOCK PIER
PF1	300 DP x 600 SQR	3-Y16 T&B	3-Y16 T&B	PAD FOOTING
SF1	300 DP x 300 WD	2-Y12 T&B	R10-400 CTS	STRIP FOOTING
B1	25 x 50 RHS			HORIZONTAL STEEL MEMBER
FP	25 x 25 SHS			FENCE PICKET

**NOTES:**

- U.N.O. BLOCKWALL REINFORCEMENT SHALL BE;  
 VERTICAL-Y12-600 CTS  
 HORIZONTAL-Y12-400 CTS
- ALL BLOCKWALL SHALL BE 200 min U.N.O.
- LAP LENGTHS:  
 Y12-500 min COG = 200  
 Y16-650 min COG = 400
- NOTES FOR STONEWALL  
 UPSTAND SHALL BE SAME AS IN DWG STP-YW-C010.
- APPLY APPROVED PAINT ON MASONRY  
 BLOCK PIERS (LIGHT BLUE COLOUR)  
 AND STEEL PICKETS AND GATE (DARK BLUE)

**LEGEND**

- DENOTE BLOCKWALL
- DENOTE NATURAL GROUND
- STONED PITCHED WALL

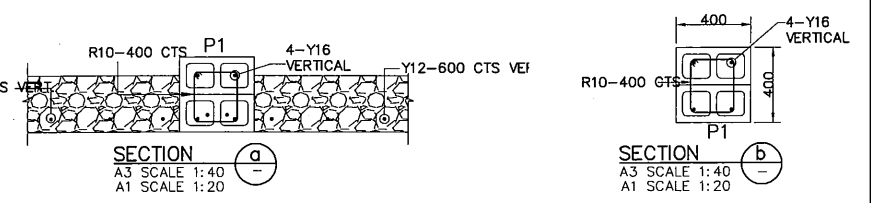
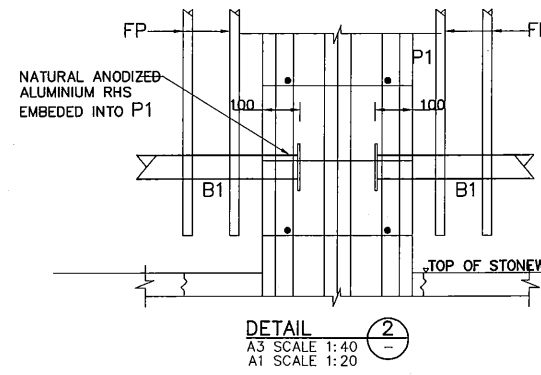
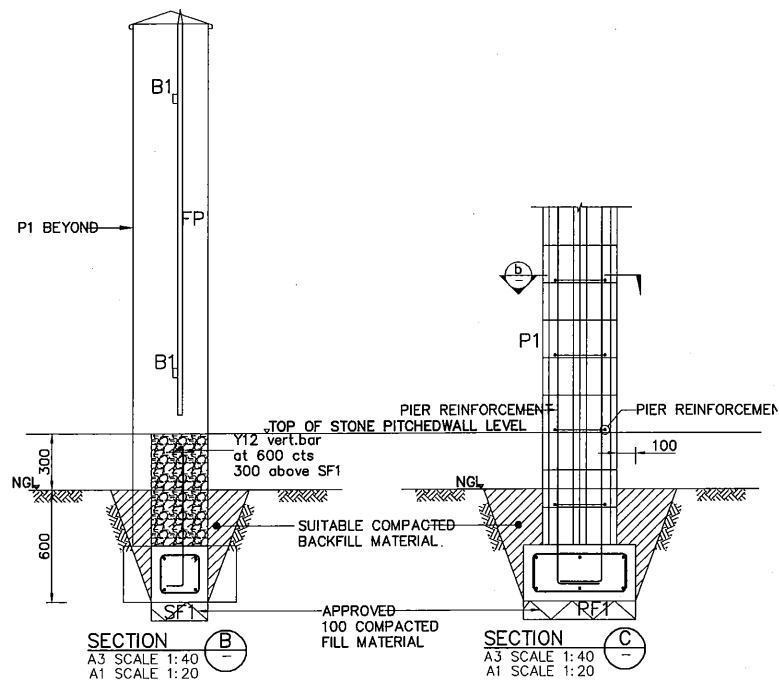
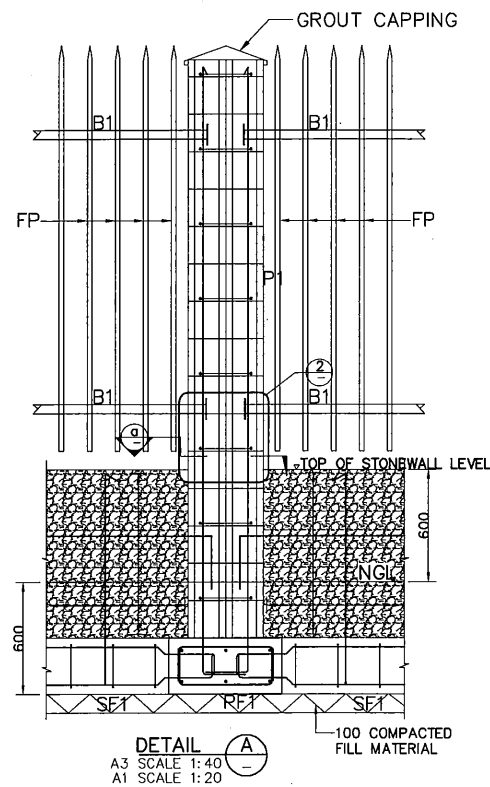

**TYPICAL PICKET FENCING DETAILS**

PROJECT: PORT MORESBY SEWERAGE SYSTEM UPGRADING PROJECT (POMSSUP)

TITLE: Kila Kila STP - STEEL PICKET FENCING DETAILS.

**IPBC** INDEPENDENT PUBLIC BUSINESS CORPORATION  
 PORT MORESBY SEWERAGE SYSTEM UPGRADING PROJECT  
 PROJECT MANAGEMENT UNIT (PMU)  
**JICA** JAPAN INTERNATIONAL COOPERATION AGENCY

CONSULTANTS:  
**NJS** NJS CONSULTANTS CO., LTD. - JAPAN

NOTES:

REVISIONS		
REV	DATE	DESCRIPTION

APPROVED by PMU:	Project Director Lot G.Zauya	DATE: 1. Dec 2011	SCALE: AS SHOWN
CHECKED by CONSULTANT:	Project Manager T.Fuji	DATE: 1. Dec 2011	DRAWING NO.: STP-YW-C016

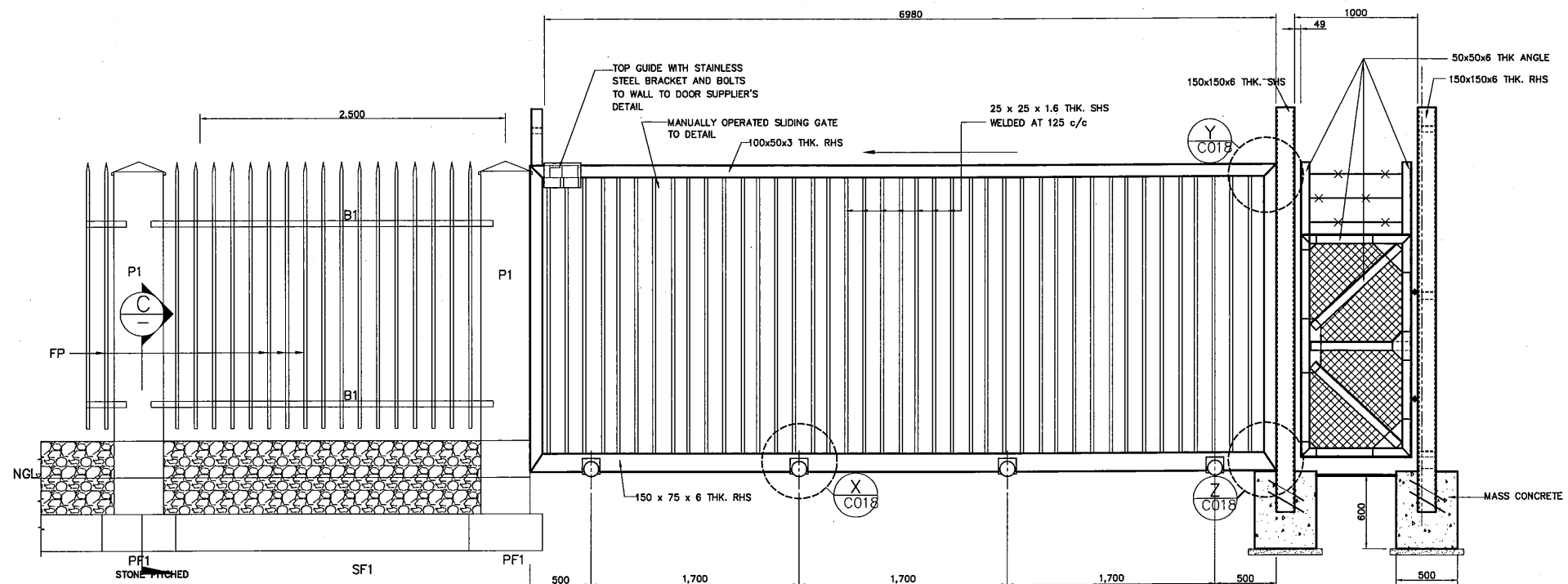

ELEVATION SLIDING GATE & SINGLE LEAF GATE AT MAIN ENTRANCE.  
 A3 SCALE 1:50  
 A1 SCALE 1:25

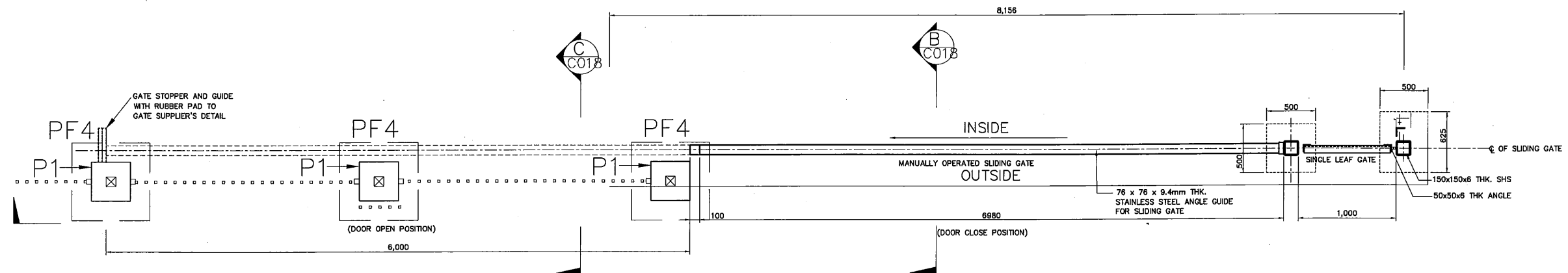

PLAN OF SLIDING GATE WITH METAL CLADDING FENCING AND SINGLE LEAF GATE AT ENTRANCE.  
 A3 SCALE 1:50  
 A1 SCALE 1:25

**METAL CLADDING FENCING & SLIDING GATE PLAN & ELEVATION.**

PROJECT: PORT MORESBY SEWERAGE SYSTEM UPGRADING PROJECT (POMSSUP)

TITLE: METAL CLADDING FENCING & SLIDING GATE PLAN & ELEVATION.



INDEPENDENT PUBLIC BUSINESS CORPORATION  
 PORT MORESBY SEWERAGE SYSTEM UPGRADING PROJECT  
 PROJECT MANAGEMENT UNIT (PMU)

CONSULTANTS:



NJS CONSULTANTS CO., LTD. - JAPAN

NOTES:

REVISIONS		
REV.	DATE	DESCRIPTION

APPROVED by PMU:	Project Director Lot G.Zauya	DATE: 1. Dec 2011	SCALE: AS SHOWN
CHECKED by CONSULTANT	Project Manager T.Fuji	DATE: 1. Dec 2011	DRAWING NO.: STP-YW-C017



JAPAN INTERNATIONAL COOPERATION AGENCY

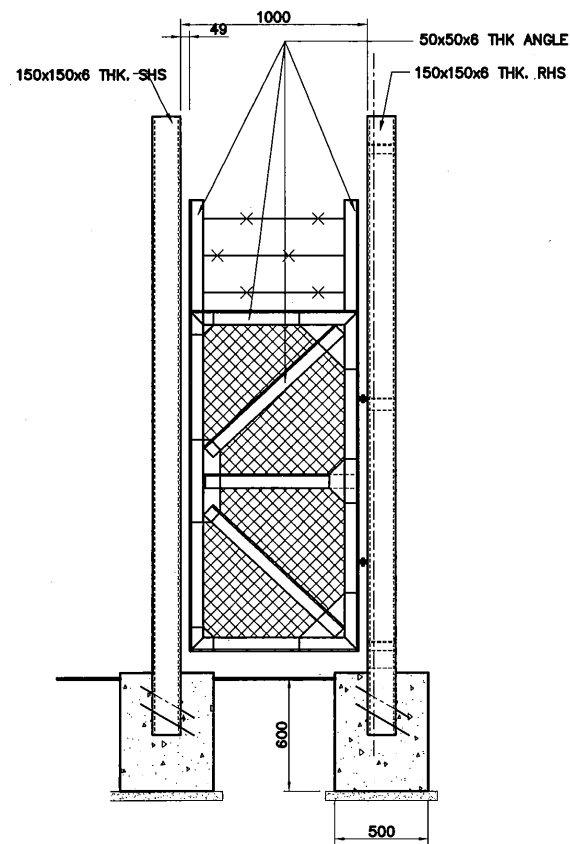

ENTRANCE/EXIT SINGLE LEAF GATE FOR O&M WORKERS.  
A3 SCALE 1:60  
A1 SCALE 1:30

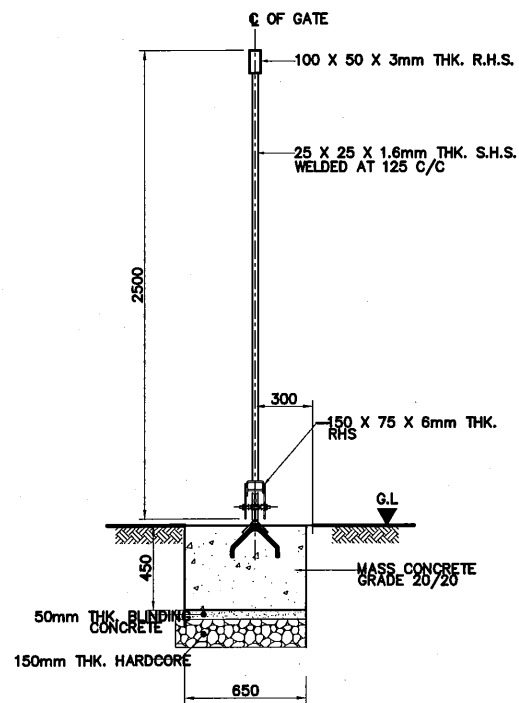

SECTION B  
A3 SCALE 1:40 C0017  
A1 SCALE 1:20

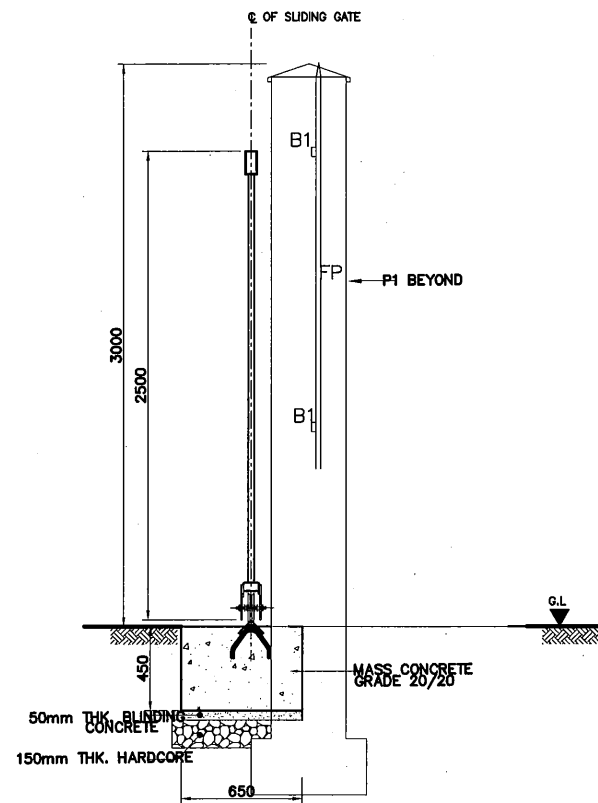

SECTION C  
A3 SCALE 1:40 C0017  
A1 SCALE 1:20

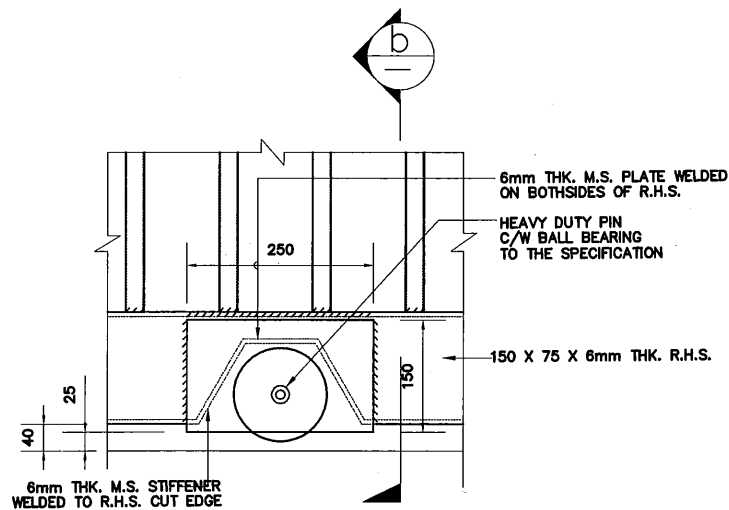

DETAIL X  
A3 SCALE 1:10 C017  
A1 SCALE 1:5

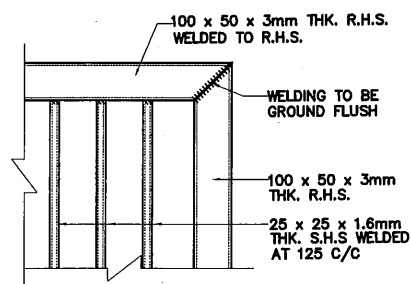

DETAIL Y  
A3 SCALE 1:20 C017  
A1 SCALE 1:10

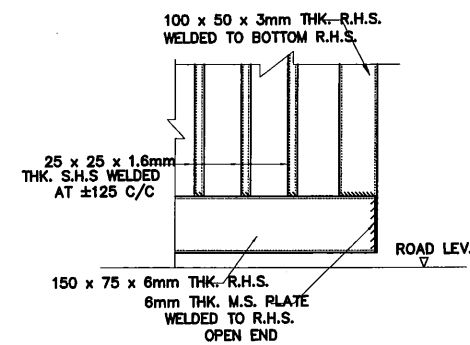

DETAIL Z  
A3 SCALE 1:20 C017  
A1 SCALE 1:10

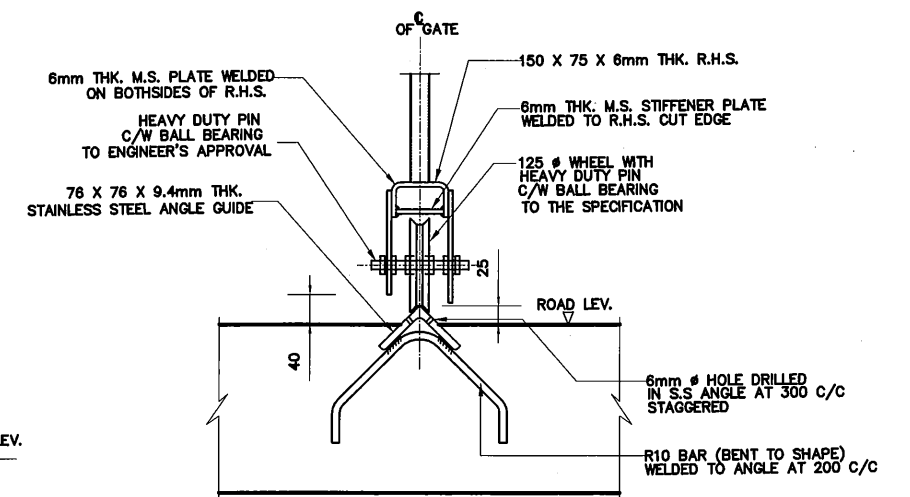

SECTION C  
A3 SCALE 1:10 C017  
A1 SCALE 1:5

SLIDING GATE DETAILS

NOTES:

1. ALL DIMENSIONS ARE IN MILLIMETRES OR UNLESS OTHERWISE STATED.
2. FOR PLAN AND SECTIONAL ELEVATION REFER DRG. No. ERI/2399/CIV/112
3. WELD THICKENERS 6mm FILLET.

PROJECT: PORT MORESBY SEWERAGE SYSTEM UPGRADING PROJECT (POMSSUP)

TITLE: Kila Kila STP - SINGLE LEAF & SLIDING GATE DETAILS.

INDEPENDENT PUBLIC BUSINESS CORPORATION  
PORT MORESBY SEWERAGE SYSTEM UPGRADING PROJECT  
PROJECT MANAGEMENT UNIT (PMU)  
JICA  
JAPAN INTERNATIONAL COOPERATION AGENCY

CONSULTANTS:  
NJS CONSULTANTS CO., LTD. - JAPAN

NOTES:

REVISIONS		
REV.	DATE	DESCRIPTION

APPROVED by PMU:	Project Director Lot G.Zauya	DATE: 1. Dec 2011	SCALE: AS SHOWN
CHECKED by CONSULTANT	Project Manager T.Fuji	DATE: 1. Dec 2011	DRAWING NO.: STP-YW-C018

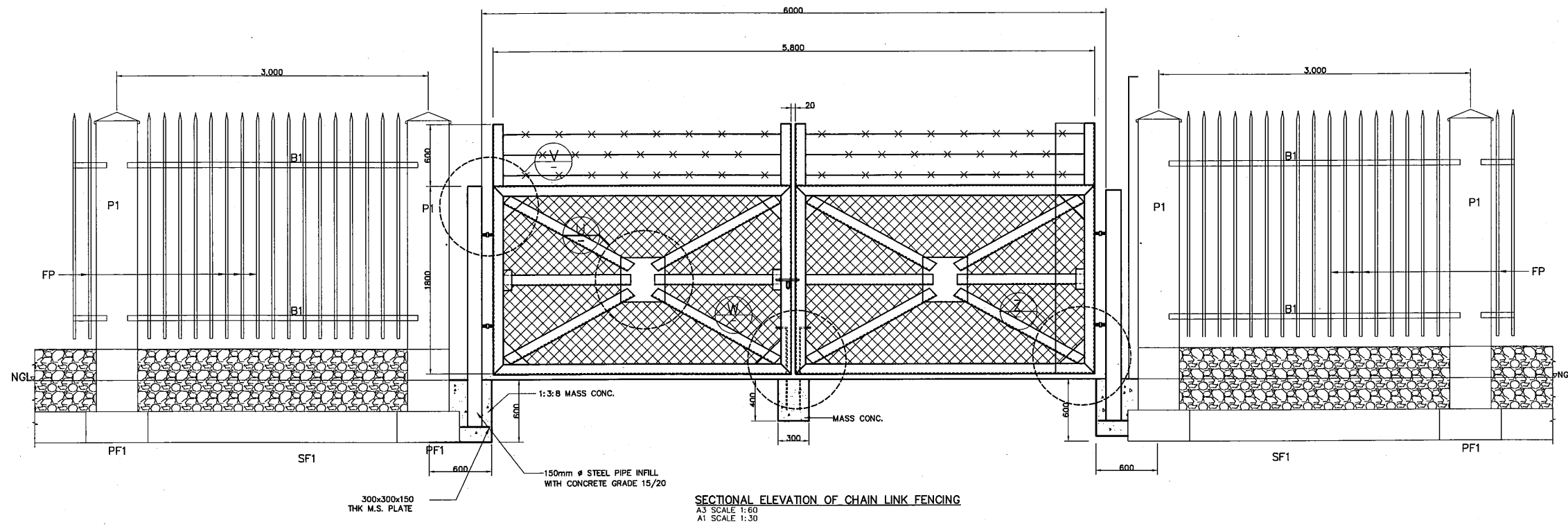

SECTIONAL ELEVATION OF CHAIN LINK FENCING  
 A3 SCALE 1:60  
 A1 SCALE 1:30

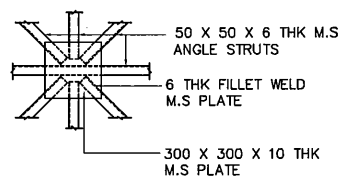

SECTION U  
 A3 SCALE 1:40  
 A1 SCALE 1:20

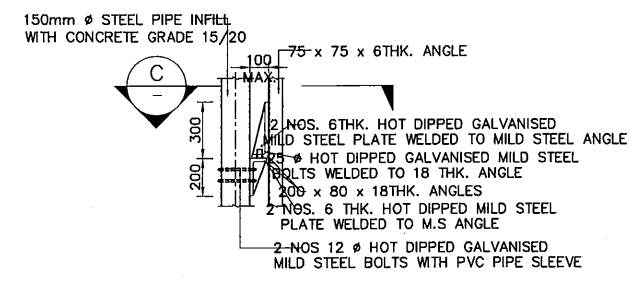

SECTION V  
 A3 SCALE 1:40  
 A1 SCALE 1:20

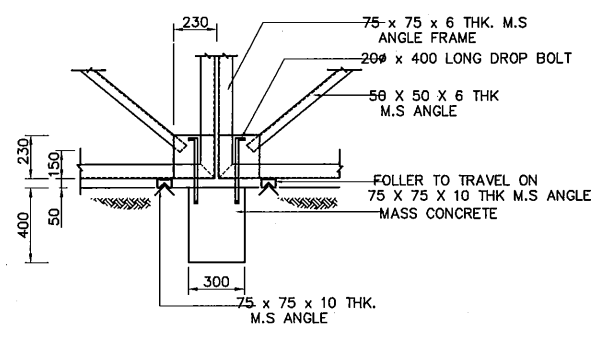

DETAIL W  
 A3 SCALE 1:40  
 A1 SCALE 1:20

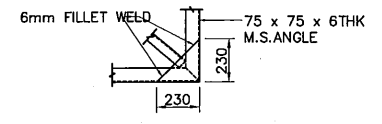

DETAIL Z  
 A3 SCALE 1:40  
 A1 SCALE 1:20

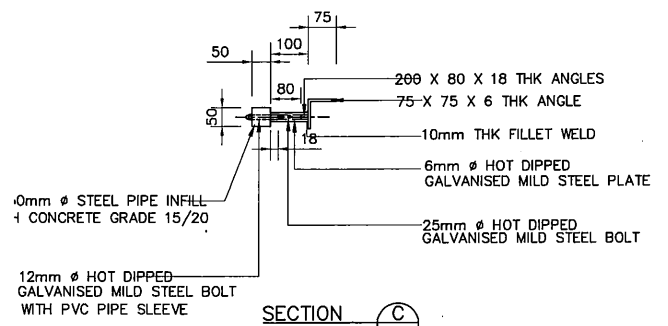

SECTION C  
 A3 SCALE 1:20  
 A1 SCALE 1:10

PROJECT: PORT MORESBY SEWERAGE SYSTEM UPGRADING PROJECT (POMSSUP) TITLE: Kila Kila STP - CHAIN LINK FENCING & GATE DEATILS.

INDEPENDENT PUBLIC BUSINESS CORPORATION  
 PORT MORESBY SEWERAGE SYSTEM UPGRADING PROJECT  
 PROJECT MANAGEMENT UNIT (PMU)  
 JICA  
 JAPAN INTERNATIONAL COOPERATION AGENCY

CONSULTANTS:  
 NJS CONSULTANTS CO., LTD. - JAPAN

NOTES:

REVISIONS		
REV.	DATE	DESCRIPTION

APPROVED by PMU:	Project Director Lot G.Zauya	DATE: 1. Dec 2011	SCALE: AS SHOWN
CHECKED by CONSULTANT	Project Manager T.Fuji	DATE: 1. Dec 2011	DRAWING NO.: STP-YW-C019

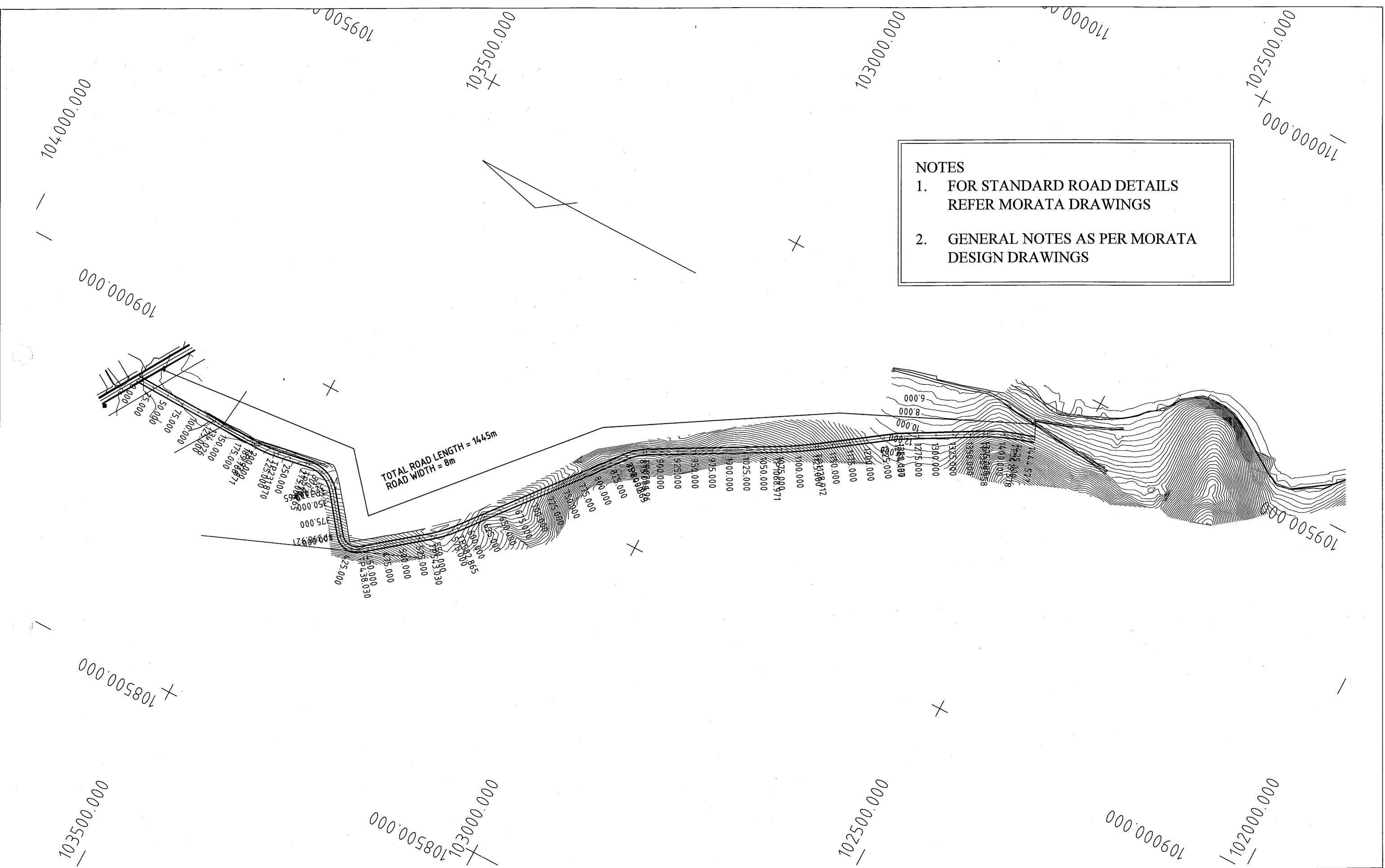

**NOTES**

1. FOR STANDARD ROAD DETAILS REFER MORATA DRAWINGS
2. GENERAL NOTES AS PER MORATA DESIGN DRAWINGS

PROJECT: PORT MORESBY SEWERAGE SYSTEM UPGRADING PROJECT (POMSSUP)		TITLE: KILAKILA STP ACCESS ROAD - General Road Layout						
CLIENT:  INDEPENDENT PUBLIC BUSINESS CORPORATION PORT MORESBY SEWERAGE SYSTEM UPGRADING PROJECT PROJECT MANAGEMENT UNIT (PMU) JAPAN INTERNATIONAL COOPERATION AGENCY	CONSULTANTS:  NJS CONSULTANTS CO., LTD. - JAPAN	NOTES:	REVISIONS			APPROVED by PMU:	DATE:	SCALE:
			REV.	DATE	DESCRIPTION	Project Director Lot G.Zauya	1. Dec 2011	1:5000
			CHECKED by CONSULTANT			DATE:	DRAWING NO.:	
			Project Manager T.Fuji			1. Dec 2011	STP-KAR-C001	

KILAKILA ACCESS ROAD Alignment Details



Chainage	Easting	Northing	Radius	TanLngth	Def Angle	Bearing
0.000	108880.888	103753.232				181°15'16" Straight
4.308	108880.794	103748.925				181°15'16" Straight
5.163	108880.775	103748.070				181°15'16" Straight
5.236	108880.773	103747.998				181°15'16" Straight
6.709	108880.741	103746.525				181°15'16" Straight
25.000	108880.341	103728.238				181°15'16" Straight
50.000	108879.793	103703.244				181°15'16" Straight
75.000	108879.246	103678.250				181°15'16" Straight
100.000	108878.699	103653.256				181°15'16" Straight
125.000	108878.151	103628.262				181°15'16" Straight
134.026	108877.954	103619.238				181°15'16" Straight
150.000	108877.604	103603.268				181°15'16" Straight
175.000	108877.057	103578.274				181°15'16" Straight
189.768	108876.734	103563.510				181°15'16" Straight
193.871	108876.644	103559.408				181°15'16" Straight
193.871	108876.644	103559.408	200.000	19.057	10°53'10"	181°15'16" Arc
200.000	108876.603	103553.279	200.000	19.057	10°53'10"	179°29'55" Arc
225.000	108878.382	103528.359	200.000	19.057	10°53'10"	172°20'12" Arc
231.870	108879.415	103521.567	200.000	19.057	10°53'10"	170°22'06" Arc
231.870	108879.415	103521.567				170°22'06" Straight
250.000	108882.448	103503.693				170°22'06" Straight
275.000	108886.631	103479.045				170°22'06" Straight
279.265	108887.345	103474.840				170°22'06" Straight
279.265	108887.345	103474.840	50.000	30.108	62°06'33"	170°22'06" Arc
300.000	108886.537	103454.269	50.000	30.108	62°06'33"	194°07'45" Arc
325.000	108874.750	103432.517	50.000	30.108	62°06'33"	222°46'37" Arc
333.465	108868.503	103426.819	50.000	30.108	62°06'33"	232°28'39" Arc
333.465	108868.503	103426.819				232°28'39" Straight
350.000	108855.389	103416.748				232°28'39" Straight
375.000	108835.562	103401.521				232°28'39" Straight
398.921	108816.590	103386.952				232°28'39" Straight
398.921	108816.590	103386.952	24.721	25.000	90°38'33"	232°28'39" Arc
400.000	108815.748	103386.276	24.721	25.000	90°38'33"	229°58'32" Arc
425.000	108807.164	103363.919	24.721	25.000	90°38'33"	172°02'02" Arc
438.030	108812.210	103352.069	24.721	25.000	90°38'33"	141°50'06" Arc
438.030	108812.210	103352.069				141°50'06" Straight
450.000	108819.607	103342.658				141°50'06" Straight
475.000	108835.055	103323.002				141°50'06" Straight
500.000	108850.503	103303.346				141°50'06" Straight
525.000	108865.952	103283.690				141°50'06" Straight
543.030	108877.093	103269.515				141°50'06" Straight
543.030	108877.093	103269.515	179.044	20.000	12°44'51"	141°50'06" Arc
550.000	108881.505	103264.120	179.044	20.000	12°44'51"	139°36'16" Arc
575.000	108898.981	103246.271	179.044	20.000	12°44'51"	131°36'15" Arc
582.865	108904.975	103241.180	179.044	20.000	12°44'51"	129°05'15" Arc
582.865	108904.975	103241.180				129°05'15" Straight
600.000	108918.275	103230.376				129°05'15" Straight
625.000	108937.680	103214.613				129°05'15" Straight

KILAKILA ACCESS ROAD Alignment Details

Chainage	Easting	Northing	Radius	TanLngth	Def Angle	Bearing
650.000	108957.084	103198.851				129°05'15" Straight
675.000	108976.489	103183.088				129°05'15" Straight
700.000	108995.893	103167.325				129°05'15" Straight
725.000	109015.298	103151.563				129°05'15" Straight
750.000	109034.703	103135.800				129°05'15" Straight
775.000	109054.107	103120.037				129°05'15" Straight
800.000	109073.512	103104.275				129°05'15" Straight
825.000	109092.916	103088.512				129°05'15" Straight
849.865	109112.216	103072.835				129°05'15" Straight
849.865	109112.216	103072.835	77.245	15.000	21°58'43"	129°05'15" Arc
850.000	109112.321	103072.749	77.245	15.000	21°58'43"	129°11'16" Arc
875.000	109128.827	103054.119	77.245	15.000	21°58'43"	147°43'53" Arc
879.496	109131.116	103050.249	77.245	15.000	21°58'43"	151°03'58" Arc
879.496	109131.116	103050.249				151°03'58" Straight
900.000	109141.036	103032.305				151°03'58" Straight
925.000	109153.131	103010.425				151°03'58" Straight
950.000	109165.226	102988.546				151°03'58" Straight
975.000	109177.321	102966.666				151°03'58" Straight
1000.000	109189.416	102944.787				151°03'58" Straight
1025.000	109201.511	102922.907				151°03'58" Straight
1050.000	109213.606	102901.028				151°03'58" Straight
1068.971	109222.784	102884.425				151°03'58" Straight
1068.971	109222.784	102884.425	551.477	30.000	6°13'39"	151°03'58" Arc
1075.000	109225.730	102879.165	551.477	30.000	6°13'39"	150°26'23" Arc
1100.000	109238.552	102857.706	551.477	30.000	6°13'39"	147°50'32" Arc
1125.000	109252.333	102836.850	551.477	30.000	6°13'39"	145°14'42" Arc
1128.912	109254.574	102833.644	551.477	30.000	6°13'39"	144°50'19" Arc
1128.912	109254.574	102833.644				144°50'19" Straight
1150.000	109266.719	102816.403				144°50'19" Straight
1175.000	109281.116	102795.965				144°50'19" Straight
1200.000	109295.513	102775.527				144°50'19" Straight
1225.000	109309.910	102755.089				144°50'19" Straight
1244.137	109320.931	102739.443				144°50'19" Straight
1244.137	109320.931	102739.443				144°50'19" Straight
1250.000	109323.785	102734.322				150°52'07" Straight
1275.000	109335.955	102712.484				150°52'07" Straight
1300.000	109348.126	102690.647				150°52'07" Straight
1325.000	109360.296	102668.809				150°52'07" Straight
1350.000	109372.466	102646.971				150°52'07" Straight
1369.758	109382.085	102629.713				150°52'07" Straight
1369.758	109382.085	102629.713	239.574	25.000	11°54'53"	150°52'07" Arc
1375.000	109384.586	102625.106	239.574	25.000	11°54'53"	152°07'20" Arc
1400.000	109395.103	102602.438	239.574	25.000	11°54'53"	158°06'05" Arc
1419.578	109401.655	102583.995	239.574	25.000	11°54'53"	162°47'00" Arc
1419.578	109401.655	102583.995				162°47'00" Straight
1425.000	109403.259	102578.816				162°47'00" Straight
1444.577	109409.054	102560.116				162°47'00" Straight

PROJECT: PORT MORESBY SEWERAGE SYSTEM UPGRADING PROJECT (POMSSUP)

TITLE: KILAKILA STP ACCESS ROAD - Center Line Setout Details

CLIENT:  INDEPENDENT PUBLIC BUSINESS CORPORATION  
 PORT MORESBY SEWERAGE SYSTEM UPGRADING PROJECT  
 PROJECT MANAGEMENT UNIT (PMU)  
 JAPAN INTERNATIONAL COOPERATION AGENCY

CONSULTANTS:  NJS CONSULTANTS CO., LTD. - JAPAN

NOTES:

REVISIONS		
REV.	DATE	DESCRIPTION

APPROVED BY PMU: Project Director Lot G.Zauya  
 CHECKED BY CONSULTANT: Project Manager T.Fuji  
 DATE: 1. Dec 2011  
 SCALE: N.T.S.  
 DRAWING NO.: STP-KAR-C002

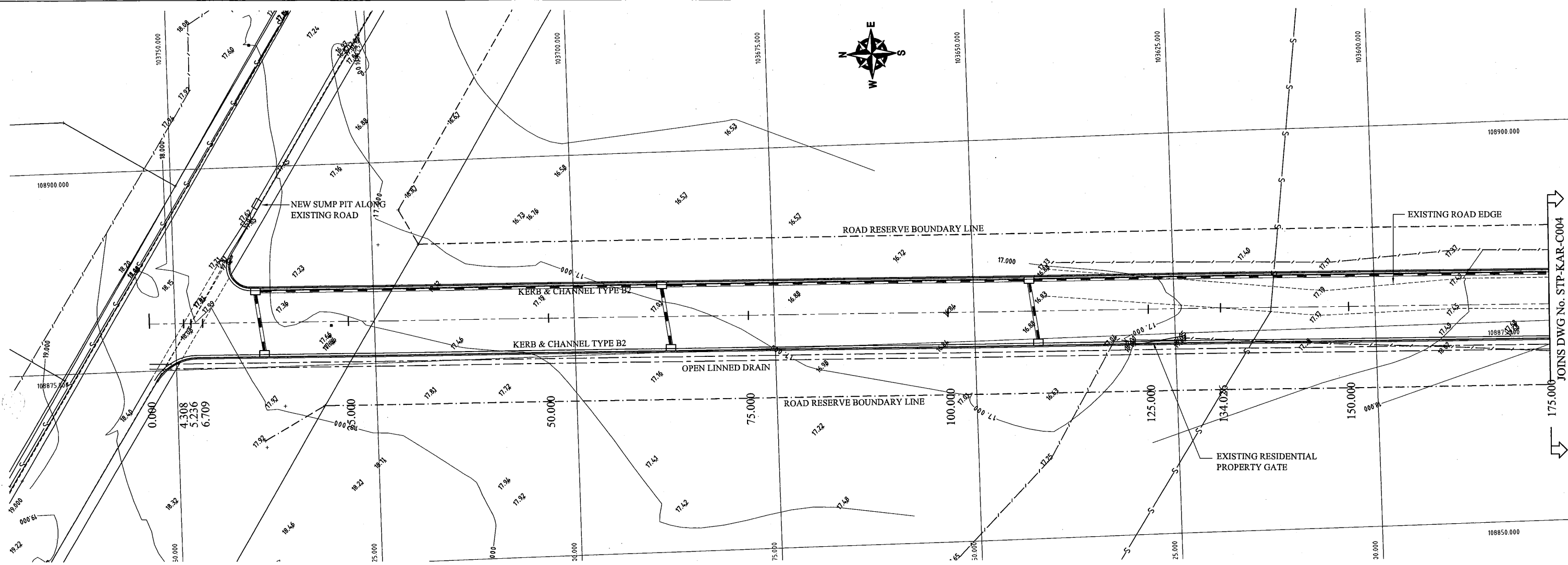

**P3 ROAD PLAN LAYOUT**  
SECTION SCALE: 1:500

DESIGN SURFACE PROFILE  
NATURAL SURFACE PROFILE

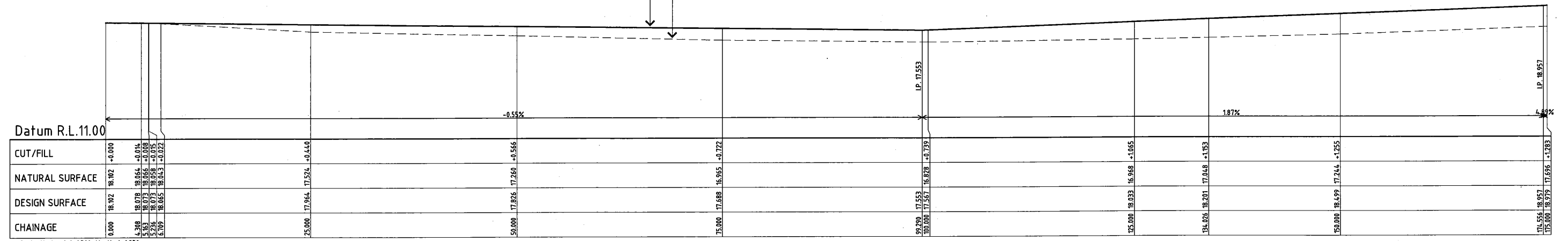

**S1 LONGITUDINAL SECTION (CH. 0.00 - CH.175.00)**  
SECTION SCALE HOR: 1:500 VERT: 1:250

PROJECT: PORT MORESBY SEWERAGE SYSTEM UPGRADING PROJECT (POMSSUP)		TITLE: KILAKILA STP ACCESS ROAD - Plan & longitudinal Section Profile	
CLIENT: <b>IPBC</b> INDEPENDENT PUBLIC BUSINESS CORPORATION <b>JICA</b> JAPAN INTERNATIONAL COOPERATION AGENCY	CONSULTANTS: <b>NJS</b> NJS CONSULTANTS CO., LTD. - JAPAN	NOTES:	APPROVED by PMU: Project Director Lot G Zauya
		REVISIONS	CHECKED by CONSULTANT Project Manager T. Fuji
		DATE: 1. Dec 2011	SCALE: AS SHOWN
		DATE: 1. Dec 2011	DRAWING NO.: STP-KAR-C003



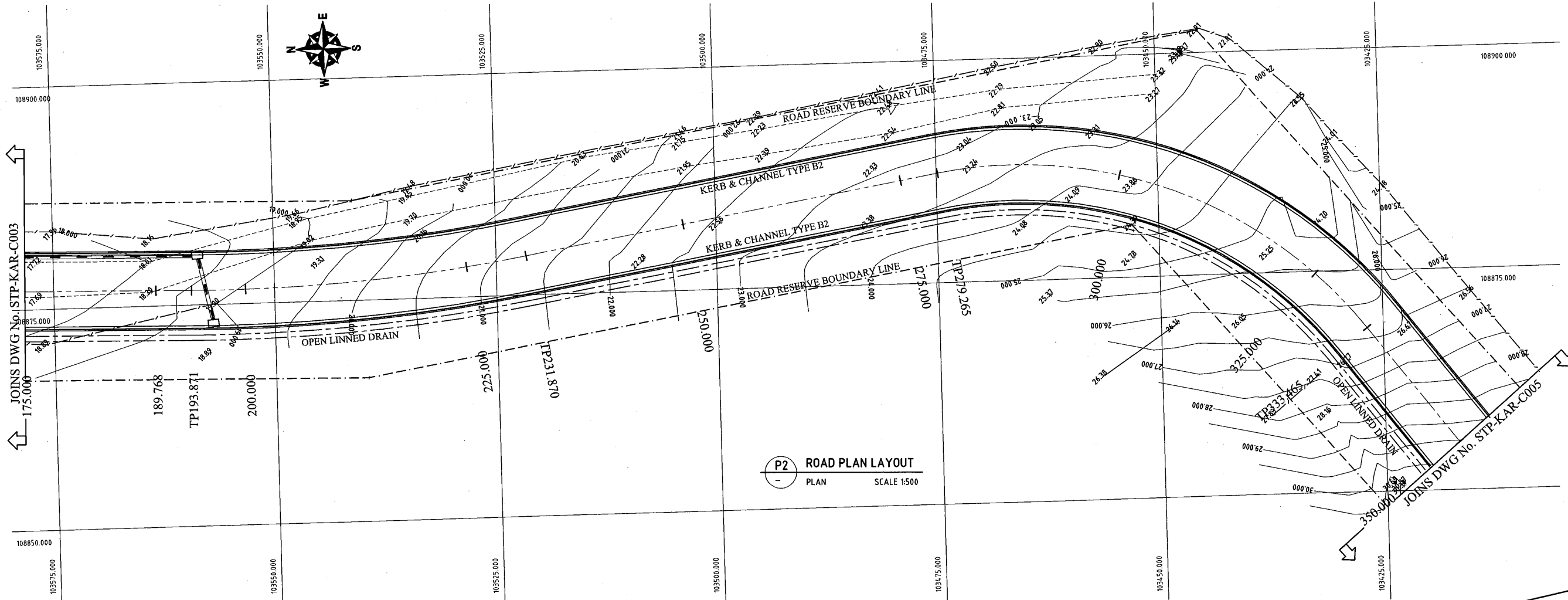

**P2 ROAD PLAN LAYOUT**  
PLAN SCALE 1:500

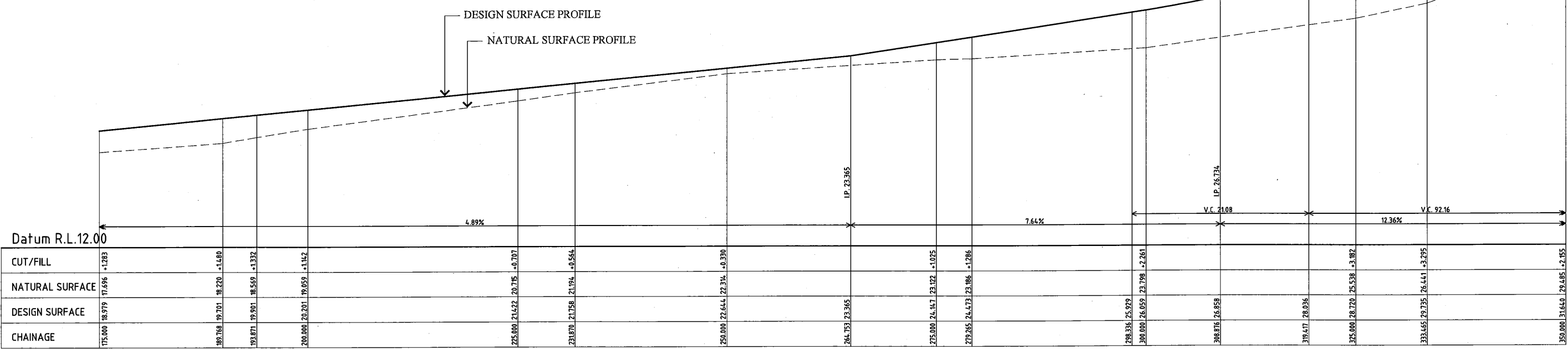

**S2 LONGITUDINAL SECTION (CH.175.00 - CH.350.00)**  
SECTION SCALE HOR. 1:500 VERT. 1:250

<b>PROJECT:</b> PORT MORESBY SEWERAGE SYSTEM UPGRADING PROJECT (POMSSUP)		<b>TITLE:</b> KILAKILA STP ACCESS ROAD - Plan & longitudinal Section Profile																
<b>CLIENT:</b>	<b>INDEPENDENT PUBLIC BUSINESS CORPORATION</b> PORT MORESBY SEWERAGE SYSTEM UPGRADING PROJECT PROJECT MANAGEMENT UNIT (PMU)	<b>CONSULTANTS:</b>	<b>NJS CONSULTANTS CO., LTD. - JAPAN</b>															
		<table border="1" style="width:100%; border-collapse: collapse;"> <thead> <tr> <th colspan="3">REVISIONS</th> </tr> <tr> <th>REV.</th> <th>DATE</th> <th>DESCRIPTION</th> </tr> </thead> <tbody> <tr><td> </td><td> </td><td> </td></tr> <tr><td> </td><td> </td><td> </td></tr> <tr><td> </td><td> </td><td> </td></tr> </tbody> </table>		REVISIONS			REV.	DATE	DESCRIPTION									
REVISIONS																		
REV.	DATE	DESCRIPTION																
<b>APPROVED by PMU:</b> Project Director Lot G.Zauya		<b>DATE:</b> 1. Dec 2011	<b>SCALE:</b> AS SHOWN															
<b>CHECKED by CONSULTANT:</b> Project Manager T.Fuji		<b>DATE:</b> 1. Dec 2011	<b>DRAWING NO.:</b> STP-KAR-C004															

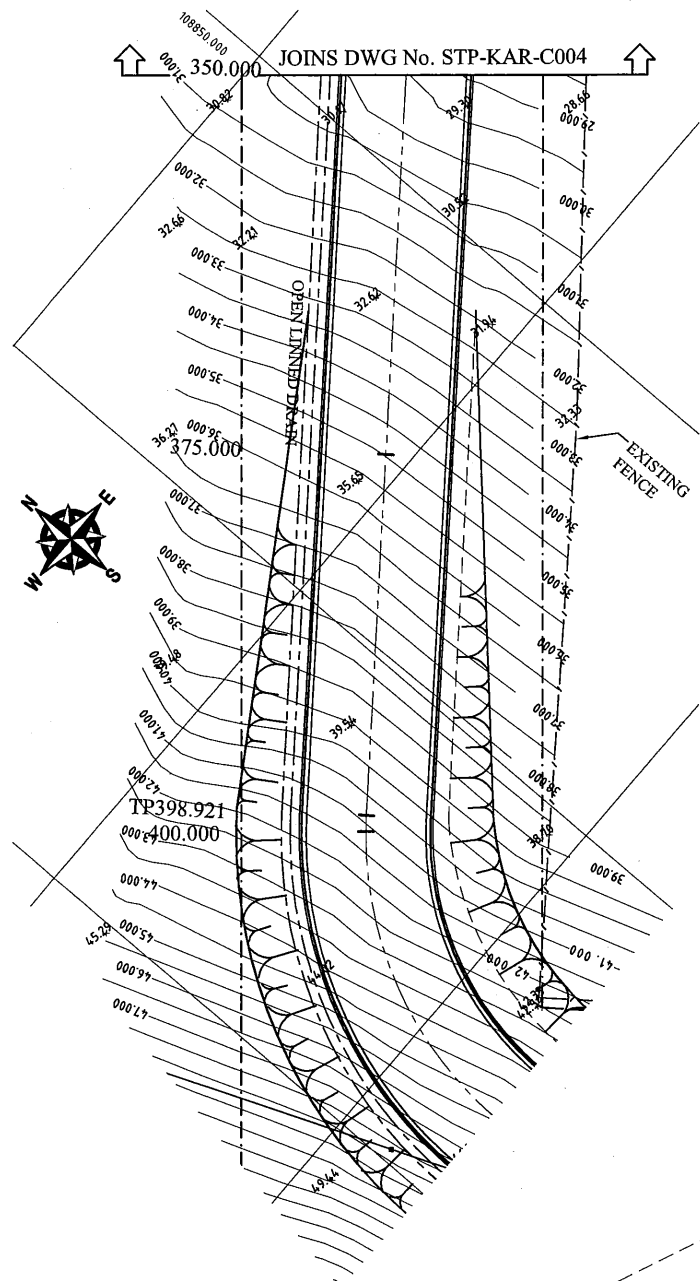

P3 ROAD PLAN LAYOUT - Part A  
SECTION SCALE. 1:500

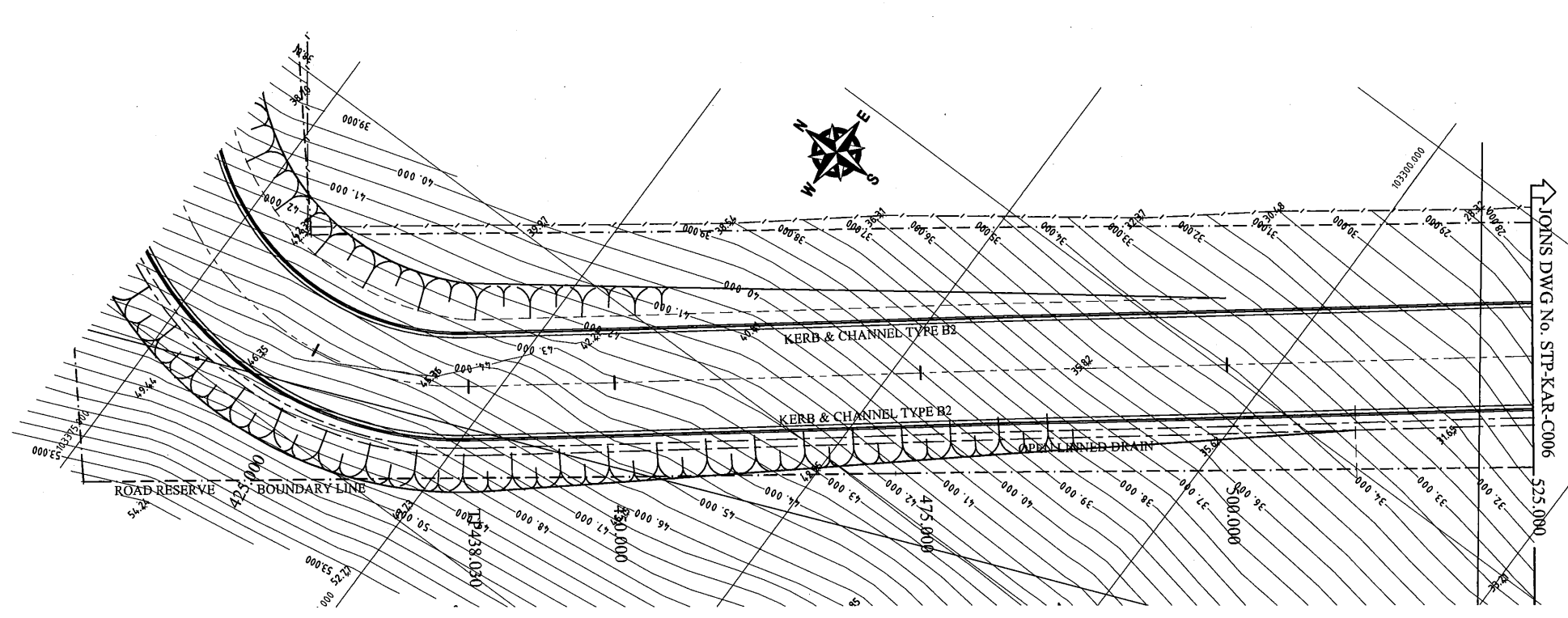

P3 ROAD PLAN LAYOUT - Part B  
SECTION SCALE. 1:500

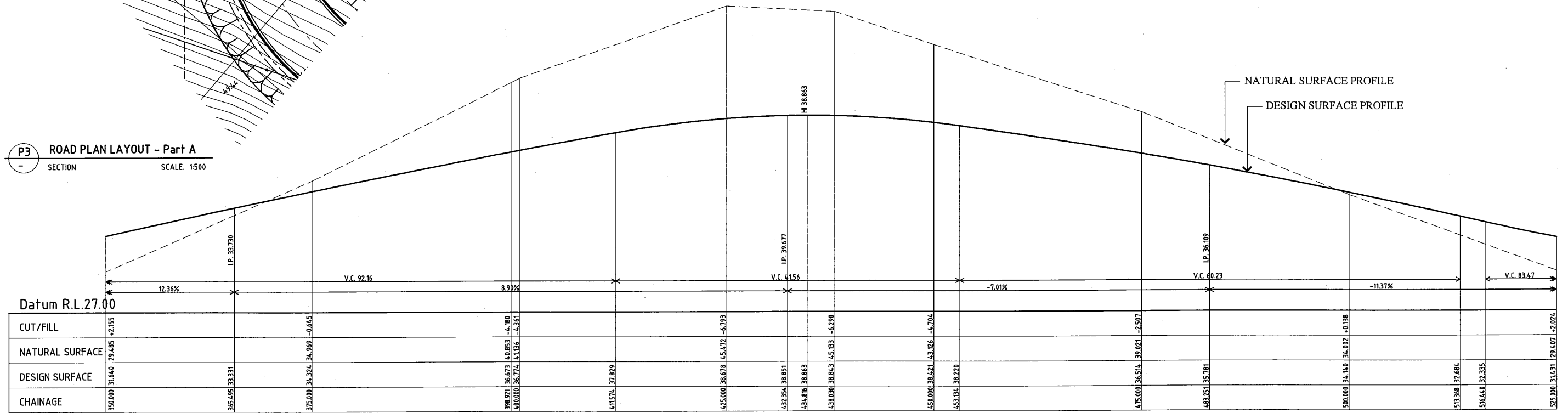

S3 LONGITUDINAL SECTION (CH.350.00 - CH.525.00)  
SECTION SCALE HOR. 1:500 VERT. 1:250

PROJECT: PORT MORESBY SEWERAGE SYSTEM UPGRADING PROJECT (POMSSUP)		TITLE: KILAKILA STP ACCESS ROAD - Plan & longitudinal Section Profile			
CLIENT:  INDEPENDENT PUBLIC BUSINESS CORPORATION JAPAN INTERNATIONAL COOPERATION AGENCY	CONSULTANTS:  NJS CONSULTANTS CO., LTD. - JAPAN	NOTES:	APPROVED by PMU: Project Director Lot G.Zauya	DATE: 1. Dec 2011	SCALE: AS SHOWN
			CHECKED by CONSULTANT: Project Manager T.Fuji	DATE: 1. Dec 2011	DRAWING NO.: STP-KAR-C005

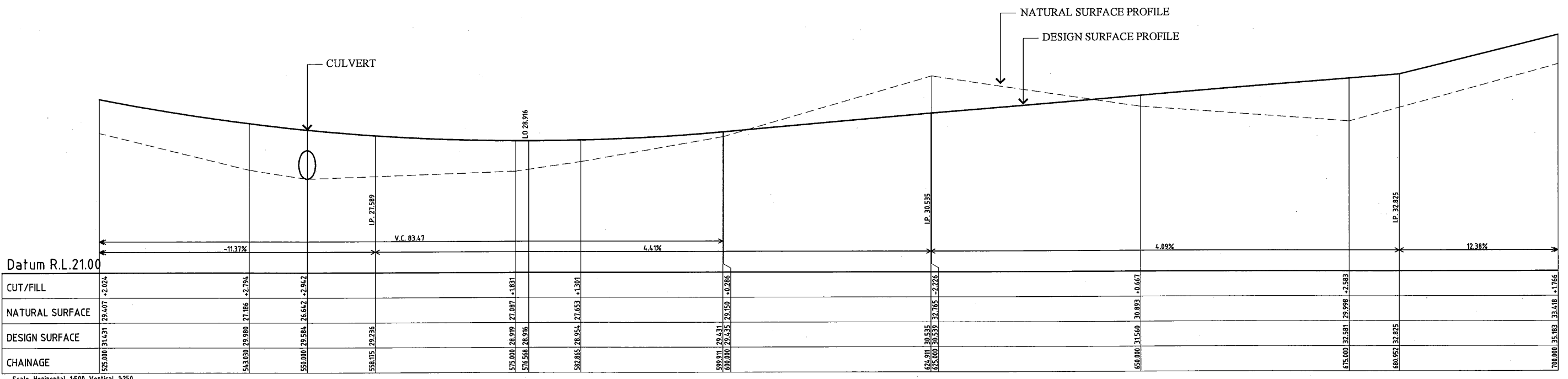
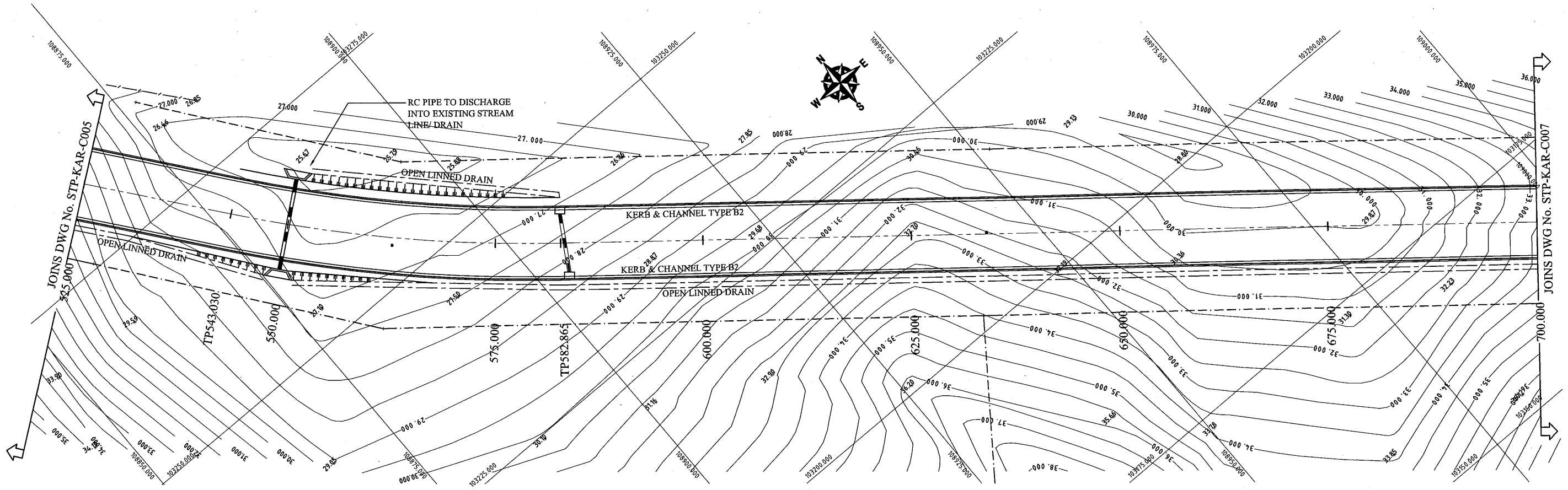

**S4** LONGITUDINAL SECTION (CH.525.00 - CH.700.00)  
SECTION SCALE HOR. 1:500 VERT. 1:250

PROJECT: PORT MORESBY SEWERAGE SYSTEM UPGRADING PROJECT (POMSSUP)		TITLE: KILAKILA STP ACCESS ROAD - Plan & longitudinal Section Profile													
CLIENT: IPBC INDEPENDENT PUBLIC BUSINESS CORPORATION PORT MORESBY SEWERAGE SYSTEM UPGRADING PROJECT PROJECT MANAGEMENT UNIT (PMU) JICA JAPAN INTERNATIONAL COOPERATION AGENCY	CONSULTANTS: NJS CONSULTANTS CO., LTD. - JAPAN	NOTES:	<table border="1"> <thead> <tr> <th>REV.</th> <th>DATE</th> <th>REVISIONS DESCRIPTION</th> </tr> </thead> <tbody> <tr><td> </td><td> </td><td> </td></tr> <tr><td> </td><td> </td><td> </td></tr> <tr><td> </td><td> </td><td> </td></tr> </tbody> </table>	REV.	DATE	REVISIONS DESCRIPTION									
REV.	DATE	REVISIONS DESCRIPTION													
APPROVED by PMU: Project Director Lot G.Zauya		DATE: 1. Dec 2011	SCALE: AS SHOWN												
CHECKED by CONSULTANT Project Manager T.Fuji		DATE: 1. Dec 2011	DRAWING NO.: STP-KAR-C006												

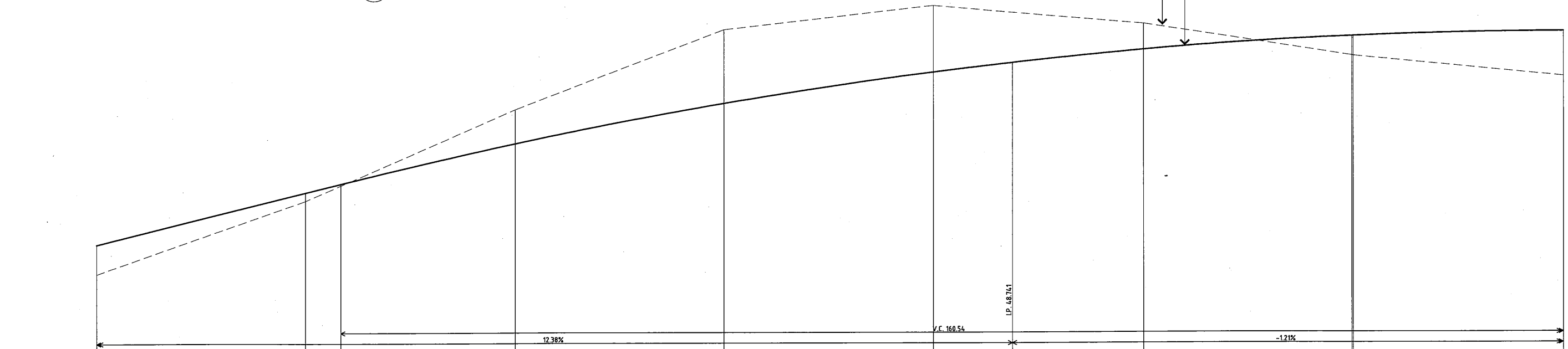
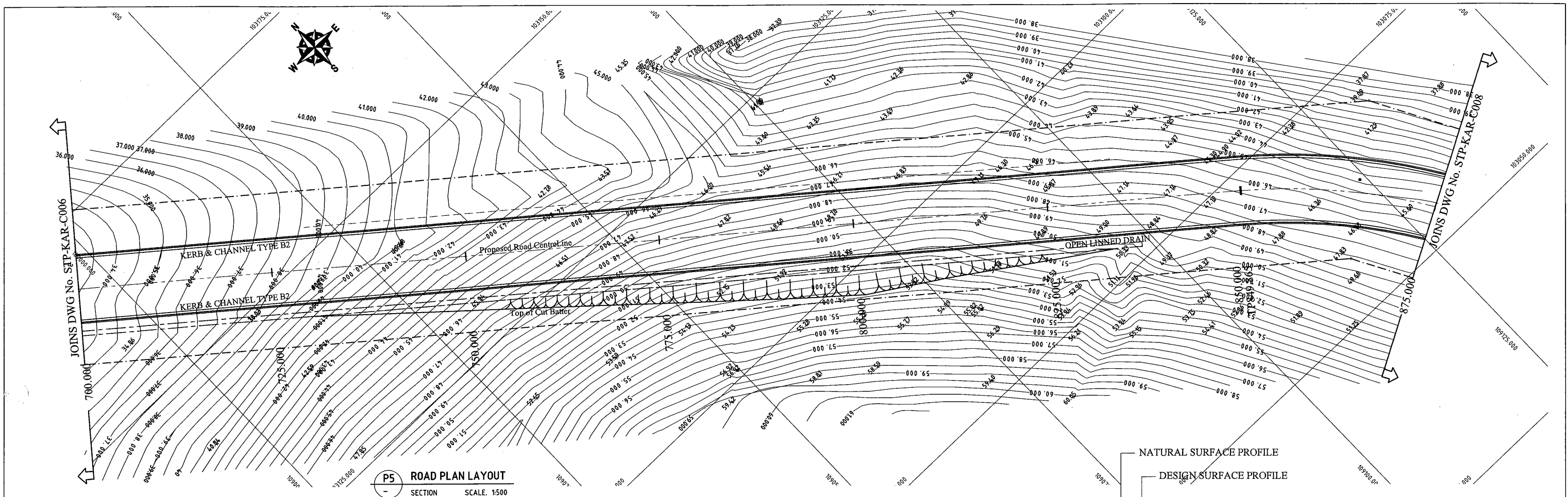

CHAINAGE	700.000	725.000	750.000	775.000	800.000	825.000	850.000	875.000
CUT/FILL								
NATURAL SURFACE	33.418	37.782	43.275	47.995	49.479	48.330	46.415	45.171
DESIGN SURFACE	35.183	38.279	44.192	48.584	49.479	48.330	46.415	45.171

Scale Horizontal 1500 Vertical 1:250

**S5** LONGITUDINAL SECTION (CH.700.00 - CH.875.00)  
SECTION SCALE HOR. 1500 VERT. 1:250

PROJECT: PORT MORESBY SEWERAGE SYSTEM UPGRADING PROJECT (POMSSUP)		TITLE: KILAKILA STP ACCESS ROAD - Plan & longitudinal Section Profile					
CLIENT:  INDEPENDENT PUBLIC BUSINESS CORPORATION JAPAN INTERNATIONAL COOPERATION AGENCY	CONSULTANTS:  NJS CONSULTANTS CO., LTD. - JAPAN	NOTES:	REVISIONS		APPROVED by PMU: Project Director Lot G.Zauya	DATE: 1. Dec 2011	SCALE: AS SHOWN
			REV.	DATE	DESCRIPTION	CHECKED by CONSULTANT Project Manager T.Fuji	DATE: 1. Dec 2011

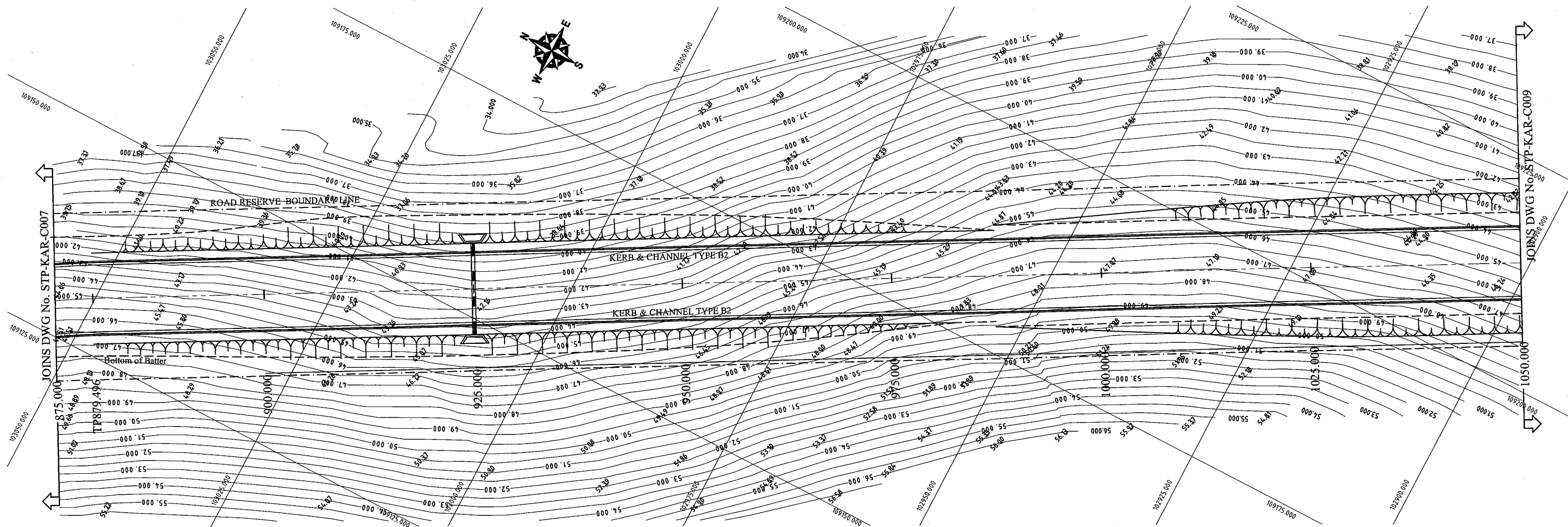

**P6 ROAD PLAN LAYOUT**  
SECTION SCALE: 1:500

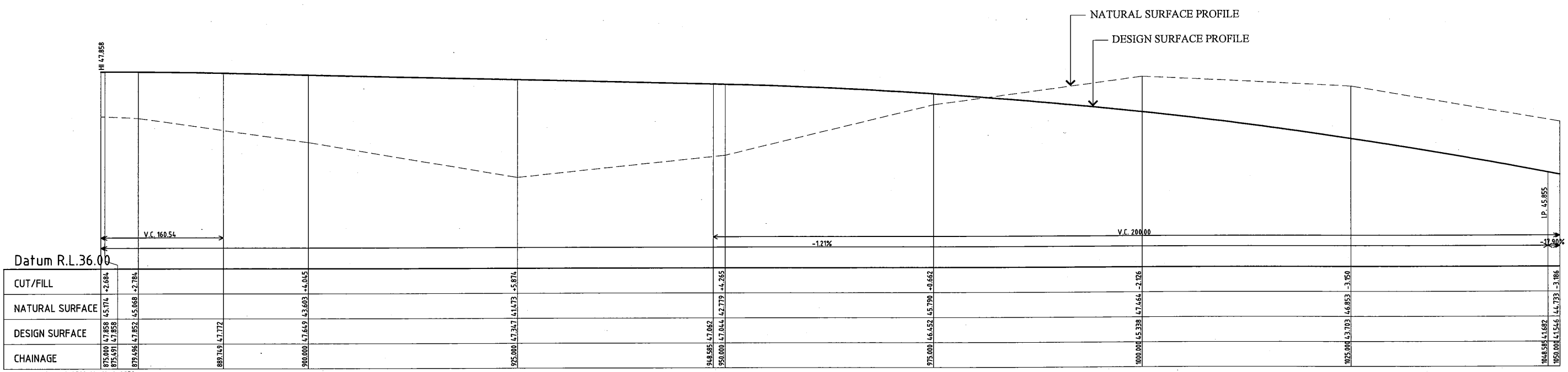

Datum R.L. 36.00

CUT/FILL	NATURAL SURFACE	DESIGN SURFACE	CHAINAGE
	47.858	47.858	875.000
	45.174	47.858	875.490
	45.068	47.852	875.491
		47.712	875.496
			883.749
			900.000
			925.000
			944.585
			950.000
			975.000
			1000.000
			1025.000
			1048.985
			1050.000

Scale Horizontal 1500 Vertical 1250

**S6 LONGITUDINAL SECTION (CH.875.00 - CH.1050.00)**  
SECTION SCALE HOR. 1:500 VERT. 1:250

PROJECT: PORT MORESBY SEWERAGE SYSTEM UPGRADING PROJECT (POMSSUP)		TITLE: KILAKILA STP ACCESS ROAD - Plan & longitudinal Section Profile																		
CLIENT: <b>IPBC</b> INDEPENDENT PUBLIC BUSINESS CORPORATION <b>JICA</b> JAPAN INTERNATIONAL COOPERATION AGENCY	CONSULTANTS: <b>NJS CONSULTANTS CO., LTD. - JAPAN</b>	NOTES:	APPROVED by PMU: Project Director Lot G.Zaiya																	
		<table border="1"> <thead> <tr> <th colspan="3">REVISIONS</th> </tr> <tr> <th>REV.</th> <th>DATE</th> <th>DESCRIPTION</th> </tr> </thead> <tbody> <tr> <td> </td> <td> </td> <td> </td> </tr> <tr> <td> </td> <td> </td> <td> </td> </tr> <tr> <td> </td> <td> </td> <td> </td> </tr> </tbody> </table>	REVISIONS			REV.	DATE	DESCRIPTION										<table border="1"> <tr> <td>DATE: 1. Dec 2011</td> <td>SCALE: AS SHOWN</td> </tr> <tr> <td>DATE: 1. Dec 2011</td> <td>DRAWING NO.: STP-KAR-C008</td> </tr> </table>	DATE: 1. Dec 2011	SCALE: AS SHOWN
REVISIONS																				
REV.	DATE	DESCRIPTION																		
DATE: 1. Dec 2011	SCALE: AS SHOWN																			
DATE: 1. Dec 2011	DRAWING NO.: STP-KAR-C008																			

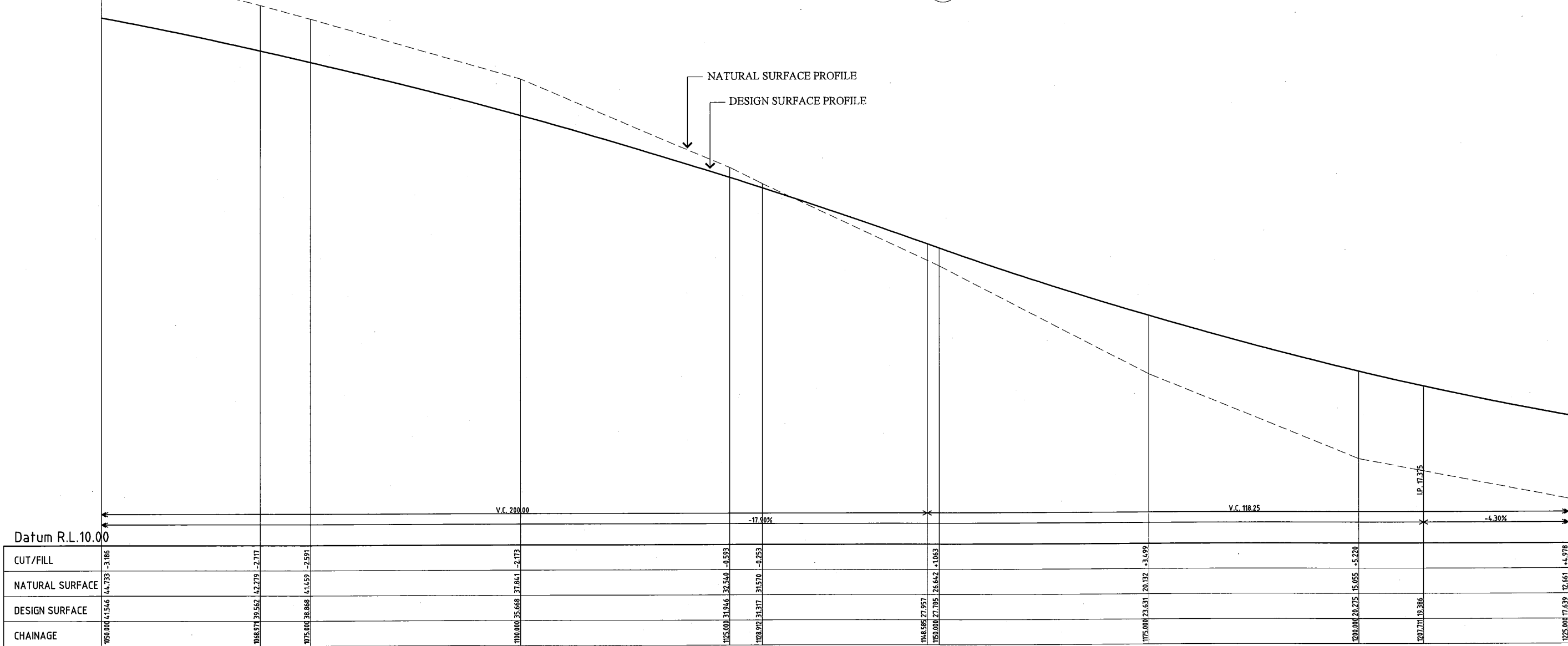
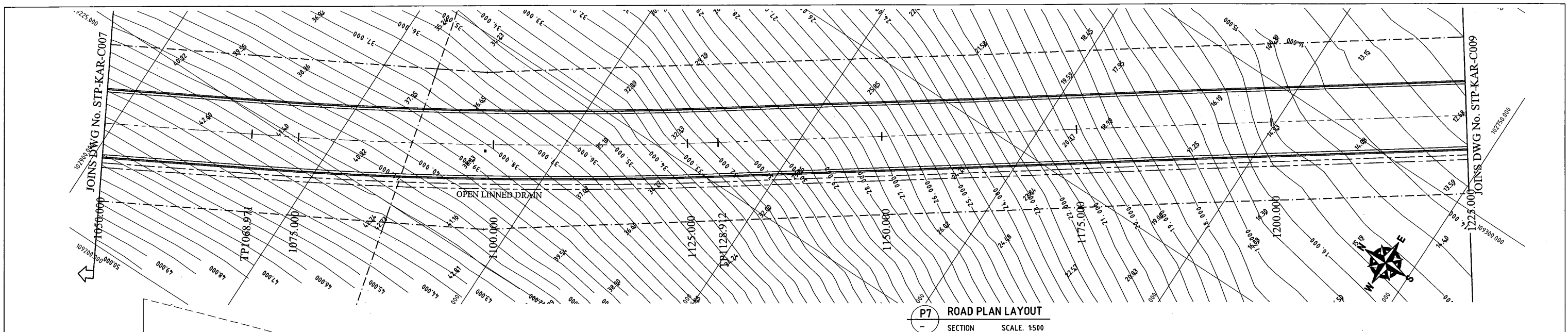

CHAINAGE	1050.000	1068.971	1075.000	1100.000	1105.000	1108.972	1148.585	1150.000	1175.000	1200.000	1207.711	1225.000
CUT/FILL		-3.186	-2.717	-2.173	-0.593	-0.253	-1.063	-3.699	-5.220	-4.978		
NATURAL SURFACE	44.733	42.279	41.659	37.864	32.540	31.570	26.642	20.352	15.955	12.651		
DESIGN SURFACE	41.546	39.562	38.868	35.668	31.946	31.317	27.795	23.651	20.775	19.386		

Scale Horizontal 1500 Vertical 1:250

**S7** LONGITUDINAL SECTION (CH.1050.00 - CH.1225.00)  
SECTION SCALE HOR. 1500 VERT. 1:250

PROJECT: PORT MORESBY SEWERAGE SYSTEM UPGRADING PROJECT (POMSSUP)		TITLE: KILAKILA STP ACCESS ROAD - Plan & longitudinal Section Profile																		
CLIENT: <b>IPBC</b> INDEPENDENT PUBLIC BUSINESS CORPORATION <b>jica</b> JAPAN INTERNATIONAL COOPERATION AGENCY	CONSULTANTS: <b>NJS CONSULTANTS CO., LTD. - JAPAN</b>	NOTES:	APPROVED by PMU: Project Director Lot G.Zauya																	
		<table border="1"> <thead> <tr> <th colspan="3">REVISIONS</th> </tr> <tr> <th>REV.</th> <th>DATE</th> <th>DESCRIPTION</th> </tr> </thead> <tbody> <tr><td> </td><td> </td><td> </td></tr> <tr><td> </td><td> </td><td> </td></tr> <tr><td> </td><td> </td><td> </td></tr> </tbody> </table>	REVISIONS			REV.	DATE	DESCRIPTION										<table border="1"> <tr> <td>DATE: 1. Dec 2011</td> <td>SCALE: AS SHOWN</td> </tr> <tr> <td>DATE: 1. Dec 2011</td> <td>DRAWING NO.: STP-KAR-C009</td> </tr> </table>	DATE: 1. Dec 2011	SCALE: AS SHOWN
REVISIONS																				
REV.	DATE	DESCRIPTION																		
DATE: 1. Dec 2011	SCALE: AS SHOWN																			
DATE: 1. Dec 2011	DRAWING NO.: STP-KAR-C009																			
CHECKED by CONSULTANT Project Manager T.Fuji																				

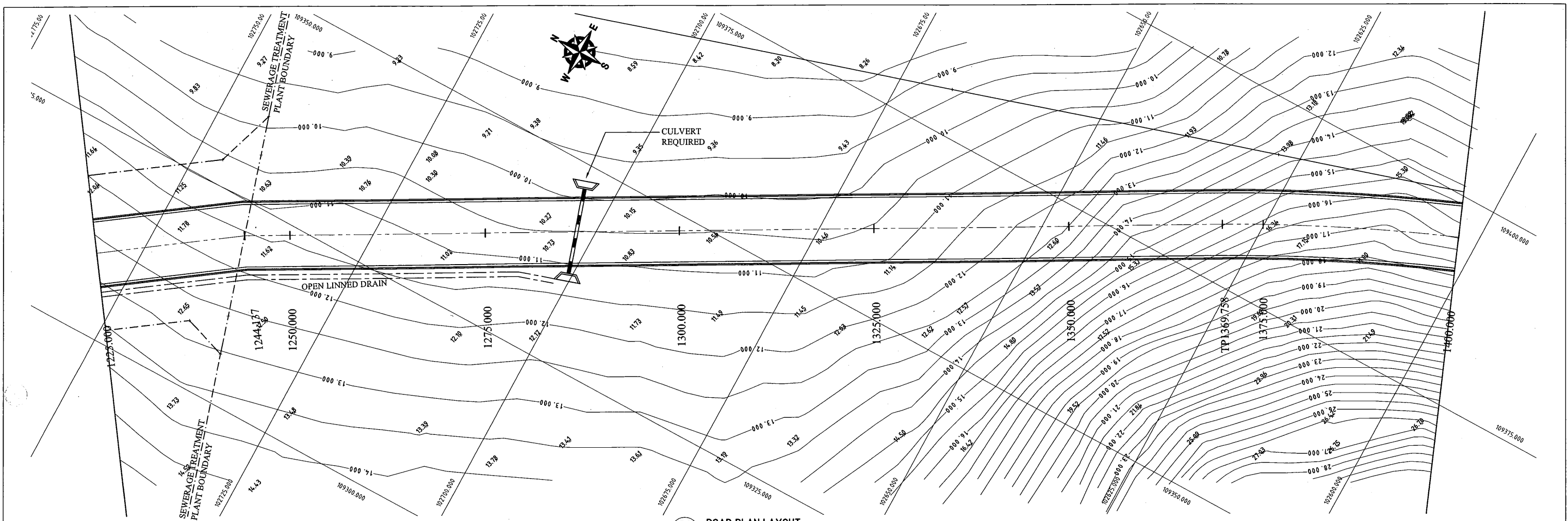

**P8 ROAD PLAN LAYOUT**  
SECTION SCALE: 1:500

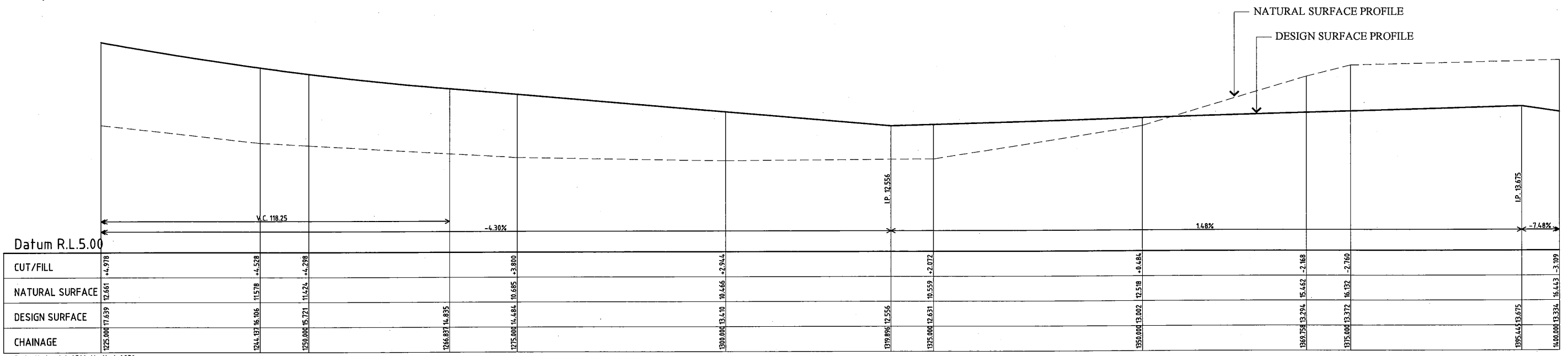

**S8 LONGITUDINAL SECTION (CH.1225.00 - CH.1400.00)**  
SECTION SCALE HOR: 1:500 VERT: 1:250

PROJECT: PORT MORESBY SEWERAGE SYSTEM UPGRADING PROJECT (POMSSUP)		TITLE: KILAKILA STP ACCESS ROAD - Plan & longitudinal Section Profile														
CLIENT: <b>IPBC</b> INDEPENDENT PUBLIC BUSINESS CORPORATION <b>jica</b> JAPAN INTERNATIONAL COOPERATION AGENCY	CONSULTANTS: <b>NJS CONSULTANTS CO., LTD. - JAPAN</b>	NOTES:	APPROVED by PMU: Project Director Lot G.Zauya													
		<table border="1"> <thead> <tr> <th colspan="3">REVISIONS</th> </tr> <tr> <th>REV.</th> <th>DATE</th> <th>DESCRIPTION</th> </tr> </thead> <tbody> <tr><td> </td><td> </td><td> </td></tr> <tr><td> </td><td> </td><td> </td></tr> <tr><td> </td><td> </td><td> </td></tr> </tbody> </table>	REVISIONS			REV.	DATE	DESCRIPTION								
REVISIONS																
REV.	DATE	DESCRIPTION														
		DATE: 1. Dec 2011	SCALE: AS SHOWN													
		DATE: 1. Dec 2011	DRAWING NO.: STP-KAR-C010													

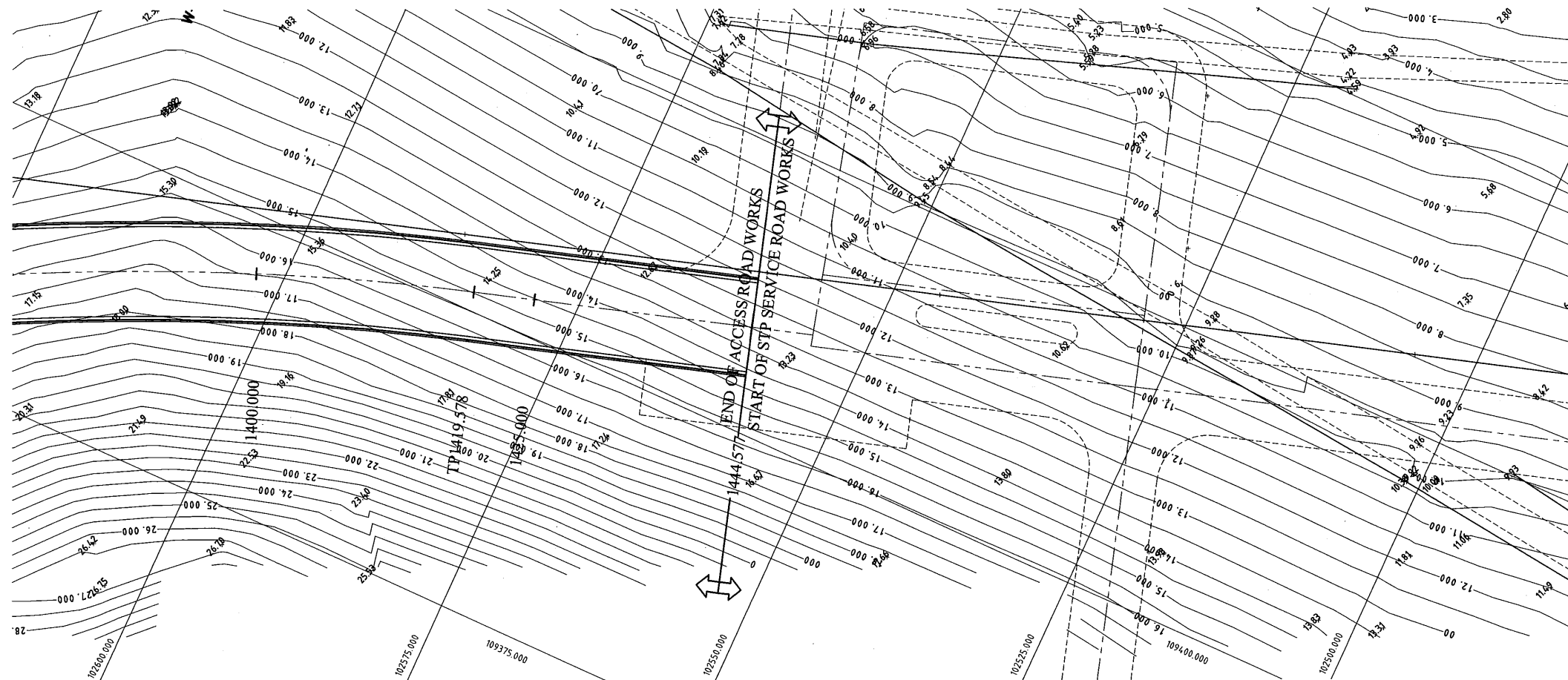

**P9 ROAD PLAN LAYOUT**  
SECTION SCALE. 1:500

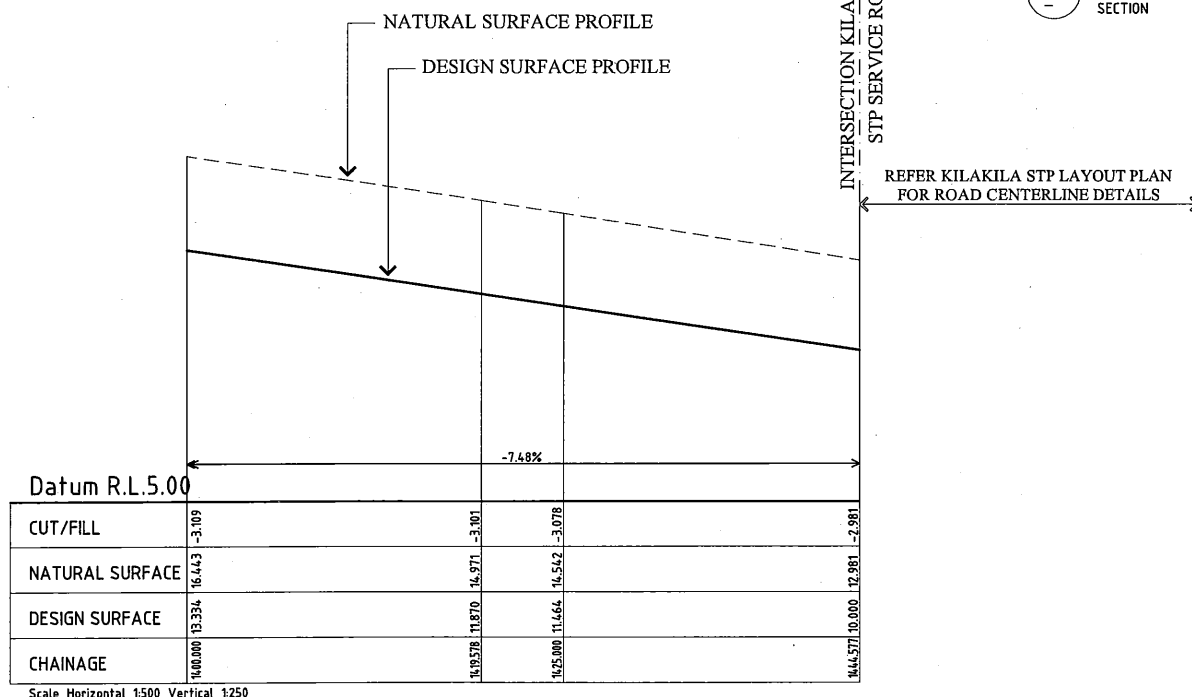

Datum R.L.5.00		-7.48%		
CUT/FILL	1440.000 -3.189	1443.000 -3.101	1444.571 -3.078	1445.000 -2.981
NATURAL SURFACE	16.443	16.971	16.562	
DESIGN SURFACE	13.334	11.870	11.464	
CHAINAGE	1440.000	1443.000	1444.571	1445.000

**S9 LONGITUDINAL SECTION (CH.1400.00 - CH.1444.58)**  
SECTION SCALE HOR. 1:500 VERT. 1:250

<b>PROJECT:</b> PORT MORESBY SEWERAGE SYSTEM UPGRADING PROJECT (POMSSUP)		<b>TITLE:</b> KILAKILA STP ACCESS ROAD - Plan & longitudinal Section Profile																					
<b>CLIENT:</b> INDEPENDENT PUBLIC BUSINESS CORPORATION PORT MORESBY SEWERAGE SYSTEM UPGRADING PROJECT PROJECT MANAGEMENT UNIT (PMU) JAPAN INTERNATIONAL COOPERATION AGENCY	<b>CONSULTANTS:</b> NJS CONSULTANTS CO., LTD. - JAPAN	<b>NOTES:</b>	<table border="1" style="width:100%; border-collapse: collapse;"> <thead> <tr> <th colspan="3">REVISIONS</th> </tr> <tr> <th>REV.</th> <th>DATE</th> <th>DESCRIPTION</th> </tr> </thead> <tbody> <tr><td> </td><td> </td><td> </td></tr> <tr><td> </td><td> </td><td> </td></tr> <tr><td> </td><td> </td><td> </td></tr> </tbody> </table>	REVISIONS			REV.	DATE	DESCRIPTION										<table border="1" style="width:100%; border-collapse: collapse;"> <tr> <td style="width:50%; vertical-align: top;"> <b>APPROVED by PMU:</b>            Project Director            Lot G.Zauya         </td> <td style="width:50%; vertical-align: top;"> <b>DATE:</b>            1. Dec 2011         </td> </tr> <tr> <td style="width:50%; vertical-align: top;"> <b>CHECKED by CONSULTANT:</b>            Project Manager            T.Fuji         </td> <td style="width:50%; vertical-align: top;"> <b>DATE:</b>            1. Dec 2011         </td> </tr> </table>	<b>APPROVED by PMU:</b> Project Director Lot G.Zauya	<b>DATE:</b> 1. Dec 2011	<b>CHECKED by CONSULTANT:</b> Project Manager T.Fuji	<b>DATE:</b> 1. Dec 2011
REVISIONS																							
REV.	DATE	DESCRIPTION																					
<b>APPROVED by PMU:</b> Project Director Lot G.Zauya	<b>DATE:</b> 1. Dec 2011																						
<b>CHECKED by CONSULTANT:</b> Project Manager T.Fuji	<b>DATE:</b> 1. Dec 2011																						
<b>SCALE:</b> AS SHOWN		<b>DRAWING NO.:</b> STP-KAR-C011																					





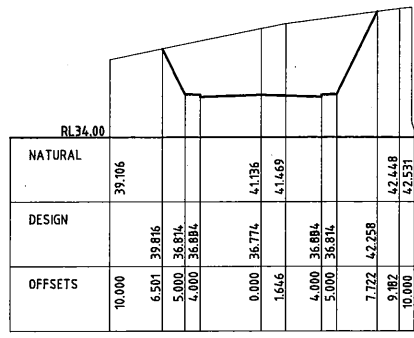

400.000

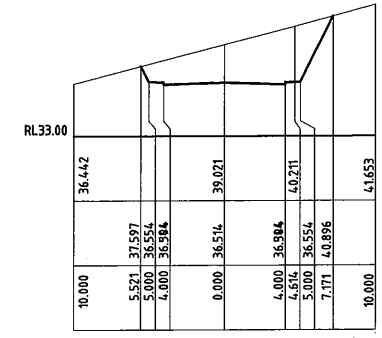

475.000

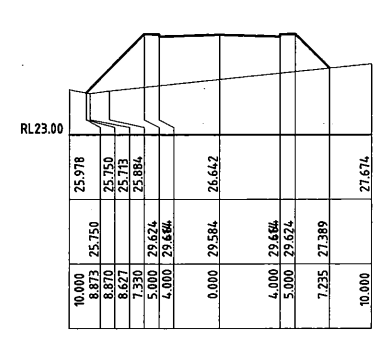

550.000

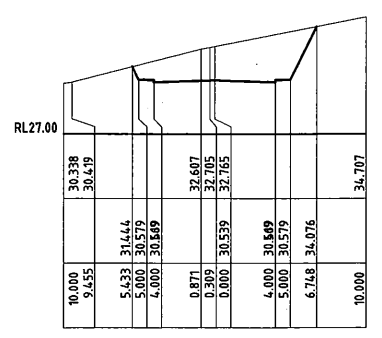

625.000

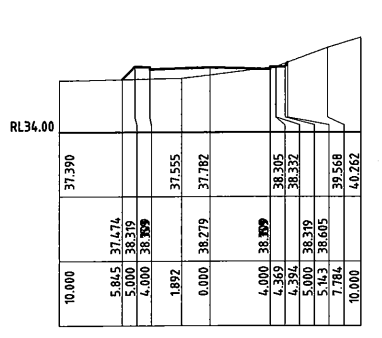

725.000

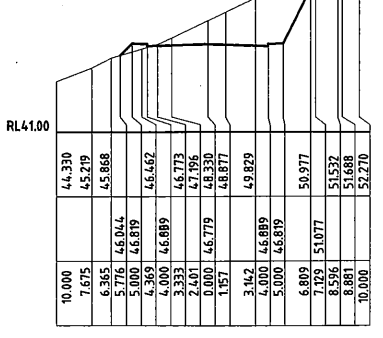

825.000

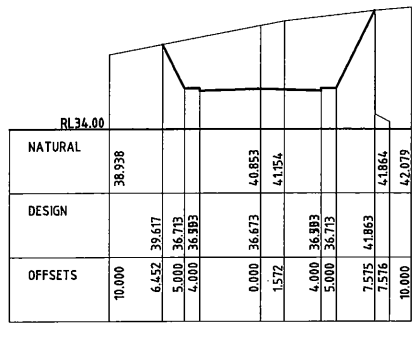

398.921

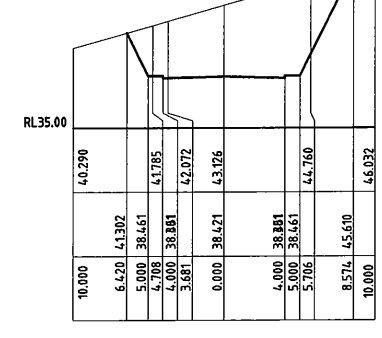

450.000

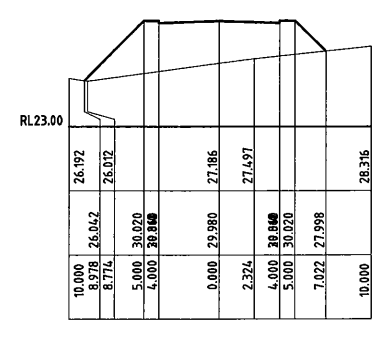

543.030

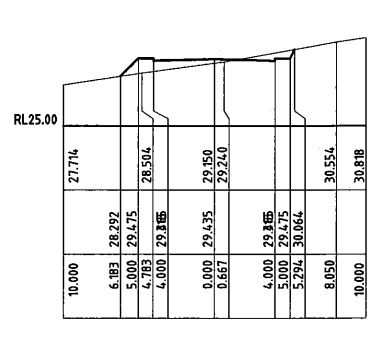

600.000

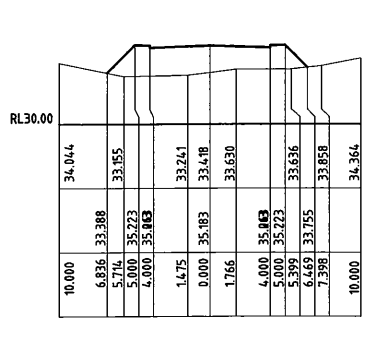

700.000

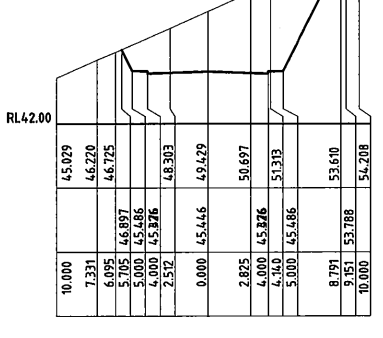

800.000

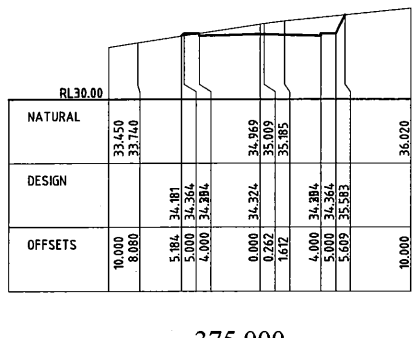

375.000

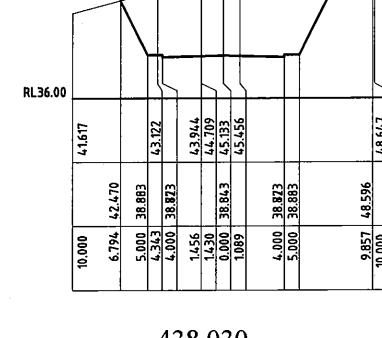

438.030

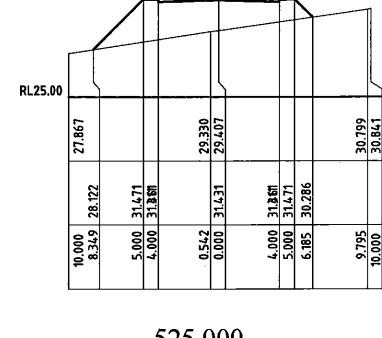

525.000

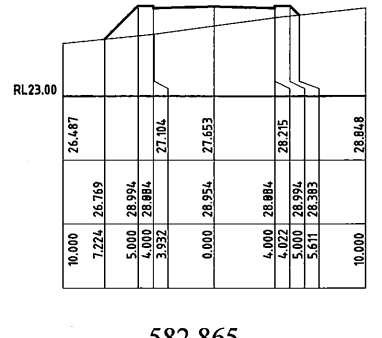

582.865

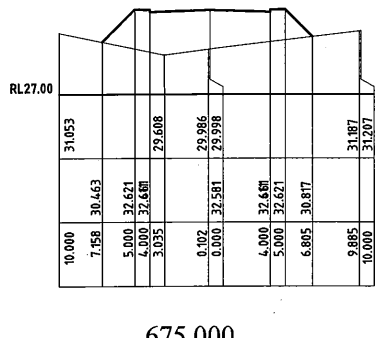

675.000

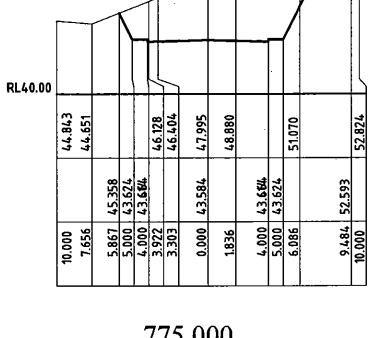

775.000

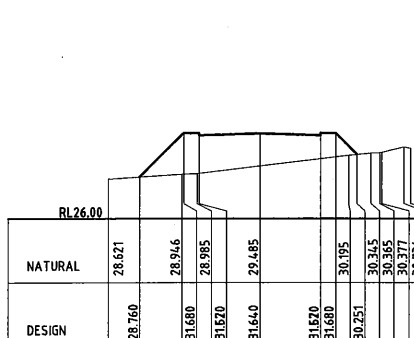

350.000

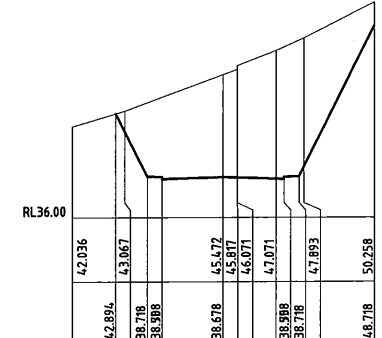

425.000

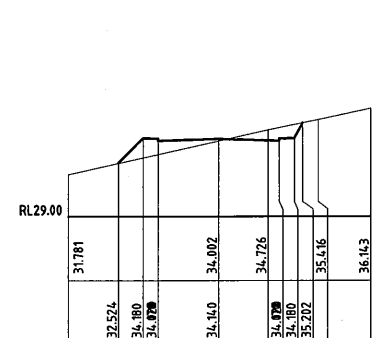

500.000

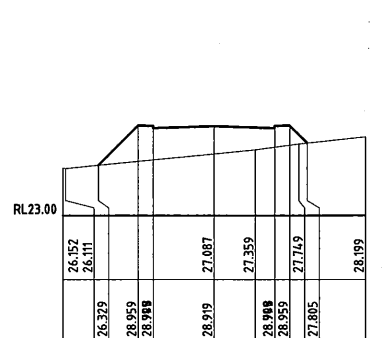

575.000

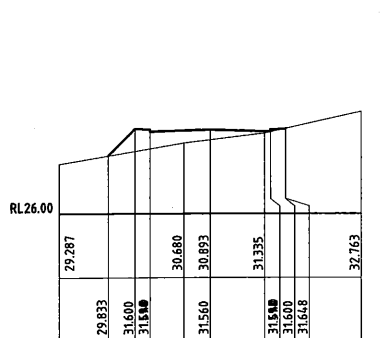

650.000

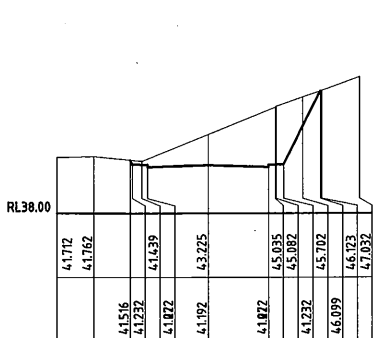

750.000

PROJECT: PORT MORESBY SEWERAGE SYSTEM UPGRADING PROJECT (POMSSUP)

CLIENT: INDEPENDENT PUBLIC BUSINESS CORPORATION  
 PORT MORESBY SEWERAGE SYSTEM UPGRADING PROJECT  
 PROJECT MANAGEMENT UNIT (PMU)  
 JAPAN INTERNATIONAL COOPERATION AGENCY

CONSULTANTS: NJS CONSULTANTS CO., LTD. - JAPAN

TITLE: KILAKILA STP ACCESS ROAD - Cross Section Profiles (Sheet 2 of 4)

NOTES:

REVISIONS		
REV.	DATE	DESCRIPTION

APPROVED BY PMU: Project Director Lot G.Zauya  
 CHECKED BY CONSULTANT: Project Manager T.Fuji

DATE: 1. Dec 2011  
 SCALE: VERT. 1:250  
 HORI. 1:250

DATE: 1. Dec 2011  
 DRAWING NO.: STP-KAR-C013

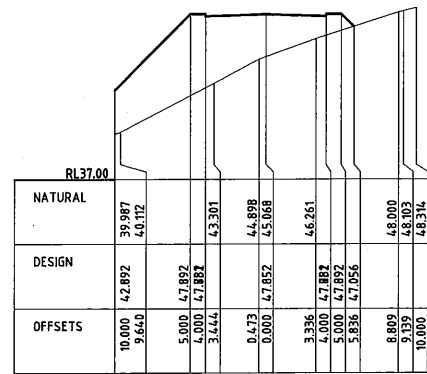

879.496

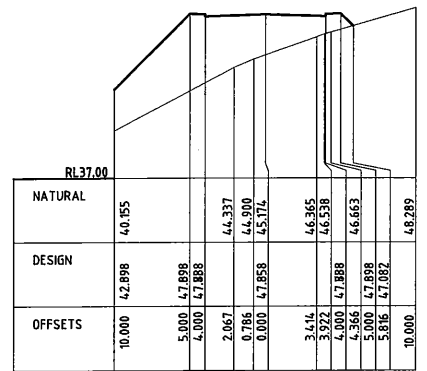

875.000

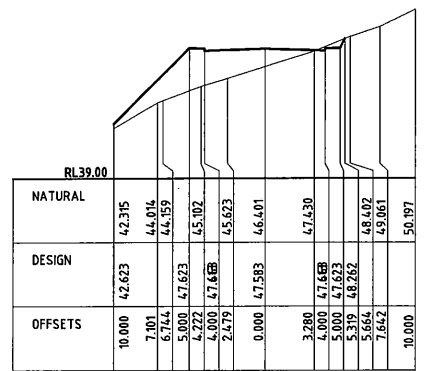

850.000

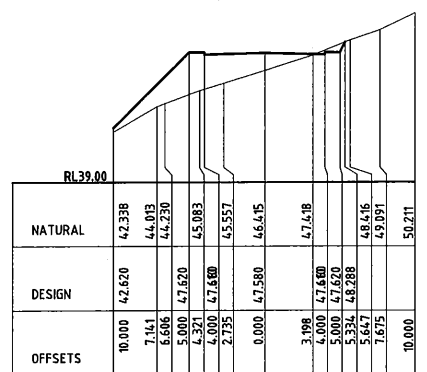

849.865

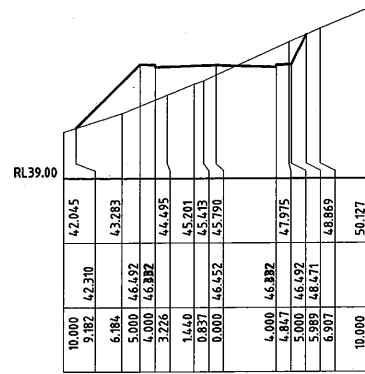

975.000

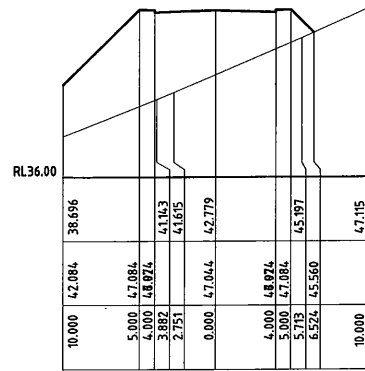

950.000

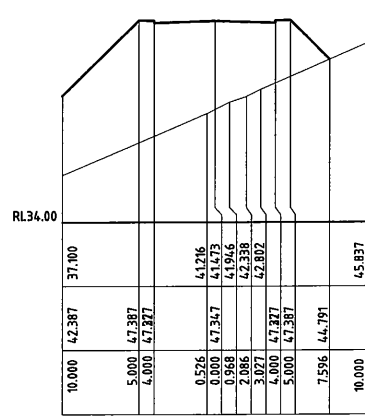

925.000

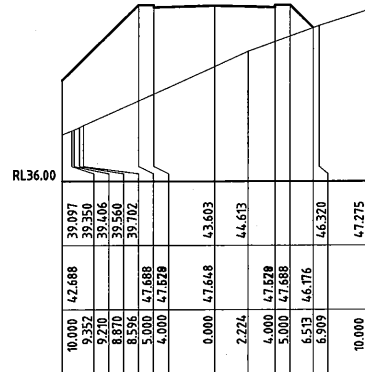

900.000

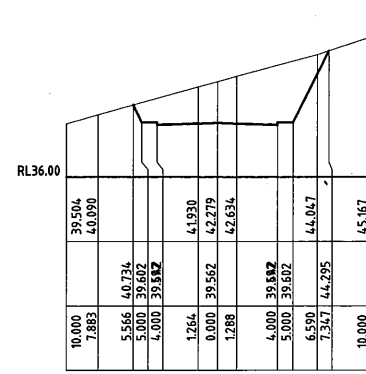

1068.971

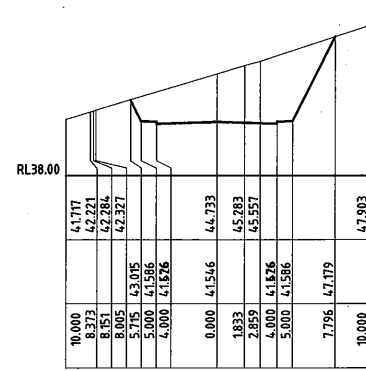

1050.000

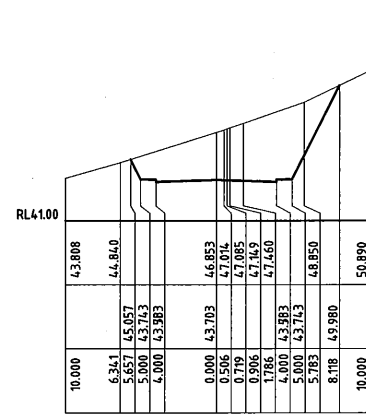

1025.000

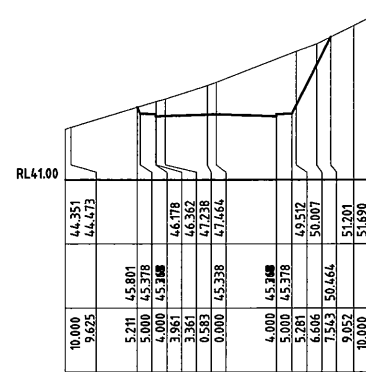

1000.000

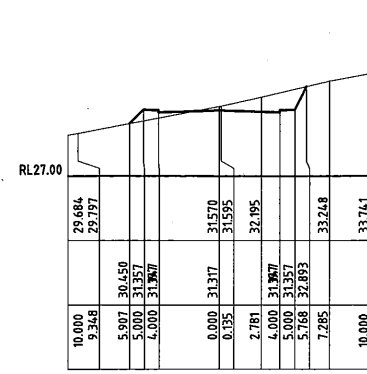

1128.912

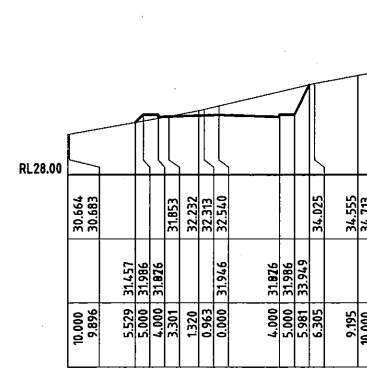

1125.000

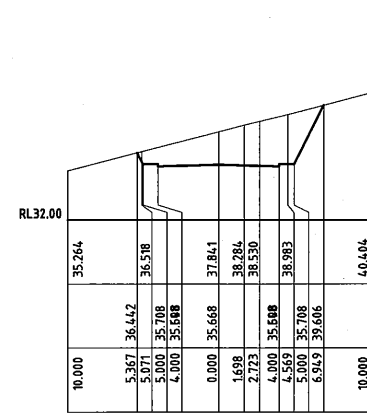

1100.000

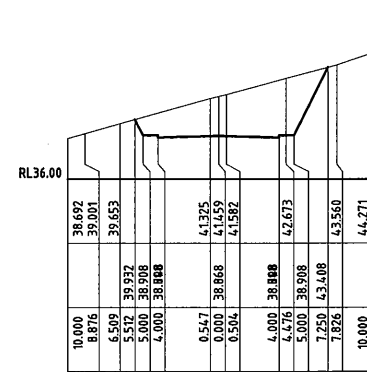

1075.000

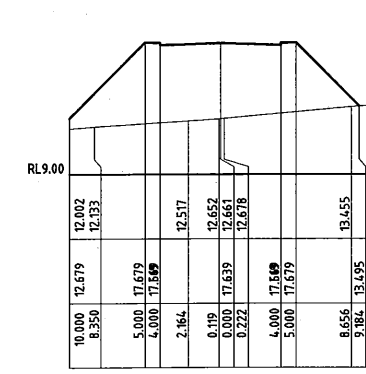

1225.000

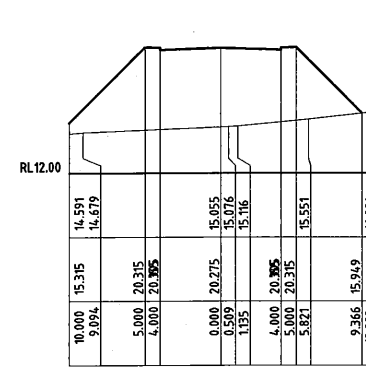

1200.000

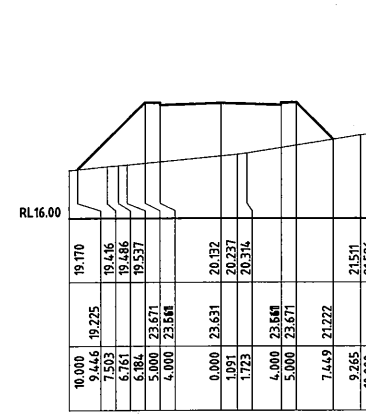

1175.000

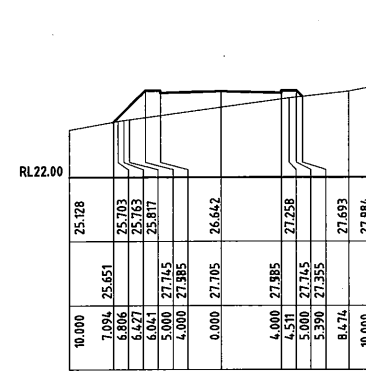

1150.000

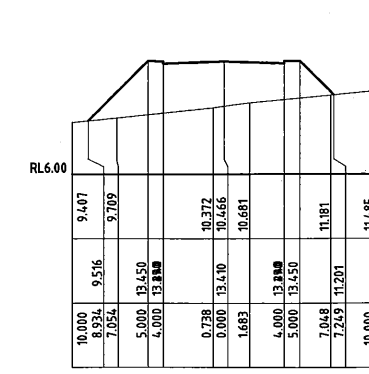

1300.000

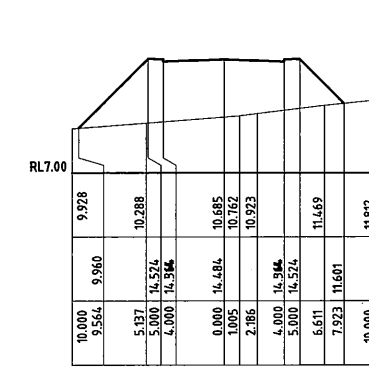

1275.000

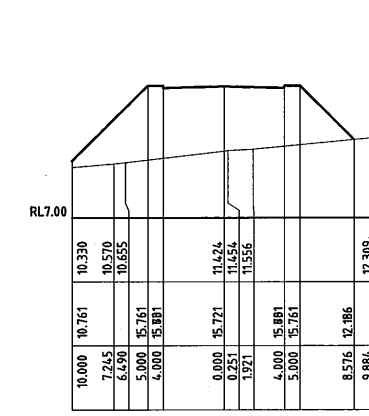

1250.000

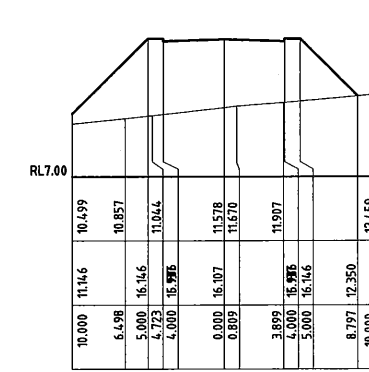

1244.137

PROJECT: PORT MORESBY SEWERAGE SYSTEM UPGRADING PROJECT (POMSSUP)

CLIENT: INDEPENDENT PUBLIC BUSINESS CORPORATION  
 PORT MORESBY SEWERAGE SYSTEM UPGRADING PROJECT  
 PROJECT MANAGEMENT UNIT (PMU)  
 JAPAN INTERNATIONAL COOPERATION AGENCY

CONSULTANTS: NJS CONSULTANTS CO., LTD. - JAPAN

TITLE: KILAKILA STP ACCESS ROAD - Cross Section Profiles (Sheet 3 of 4)

NOTES:

REVISIONS		
REV.	DATE	DESCRIPTION

APPROVED by PMU: Project Director Lot G.Zauya

CHECKED by CONSULTANT: Project Manager T.Fuji

DATE: 1. Dec 2011

SCALE: VERT. 1:250 HORI. 1:250

DRAWING NO.: STP-KAR-C014

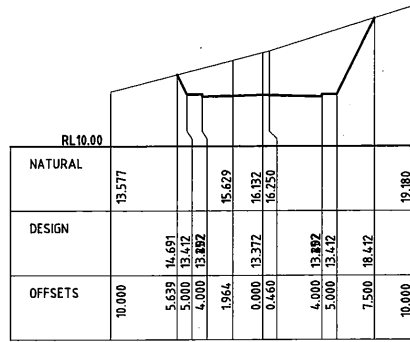

1375.000

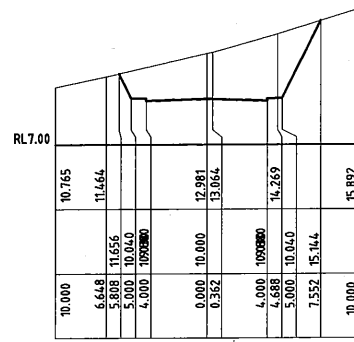

1444.577

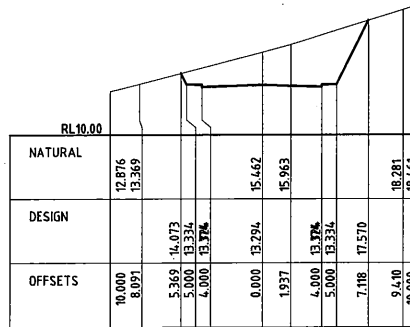

1369.758

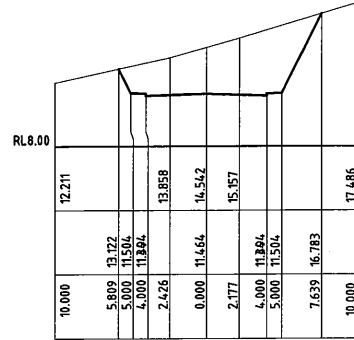

1425.000

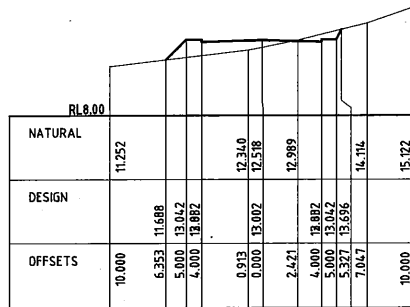

1350.000

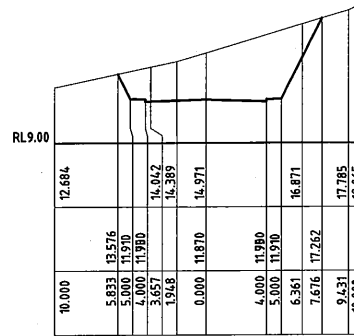

1419.578

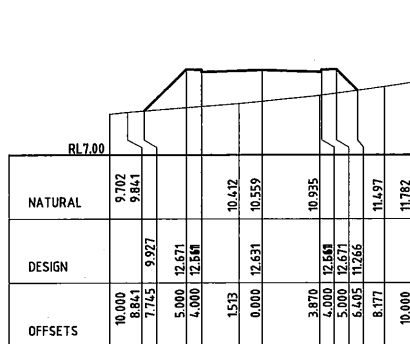

1325.000

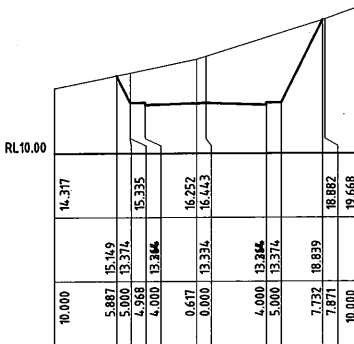

1400.000

PROJECT: PORT MORESBY SEWERAGE SYSTEM UPGRADING PROJECT (POMSSUP)

TITLE: KILAKILA STP ACCESS ROAD - Cross Section Profiles (Sheet 4 of 4)

CLIENT: INDEPENDENT PUBLIC BUSINESS CORPORATION  
 PORT MORESBY SEWERAGE SYSTEM UPGRADING PROJECT  
 PROJECT MANAGEMENT UNIT (PMU)  
 JICA JAPAN INTERNATIONAL COOPERATION AGENCY

CONSULTANTS: NJS CONSULTANTS CO., LTD. - JAPAN

NOTES:

REVISIONS		
REV.	DATE	DESCRIPTION

APPROVED by PMU:  
 Project Director  
 Lot G.Zauya

CHECKED by CONSULTANT  
 Project Manager  
 T.Fuji

DATE: 1. Dec 2011

SCALE: VERT. 1:250  
 HORI. 1:250

DATE: 1. Dec 2011

DRAWING NO.: STP-KAR-C015

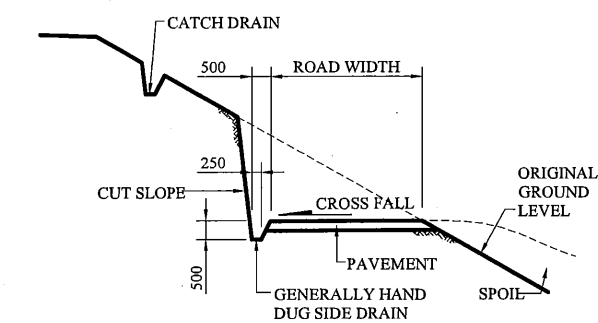
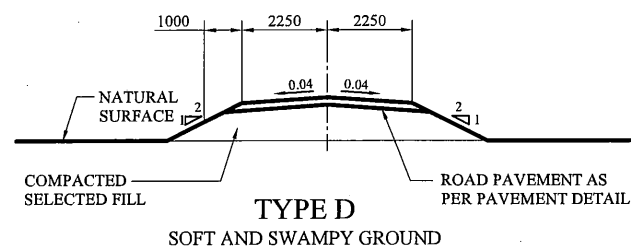
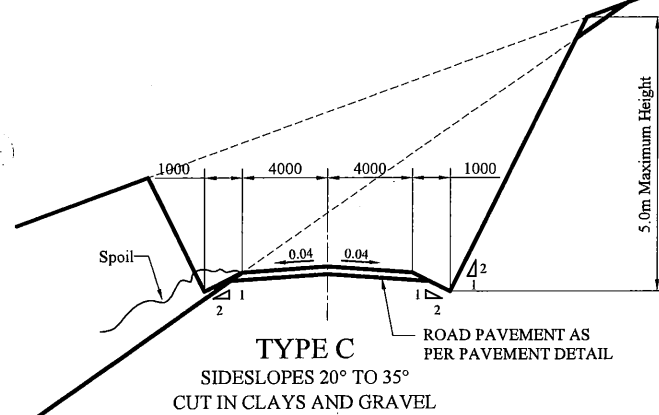
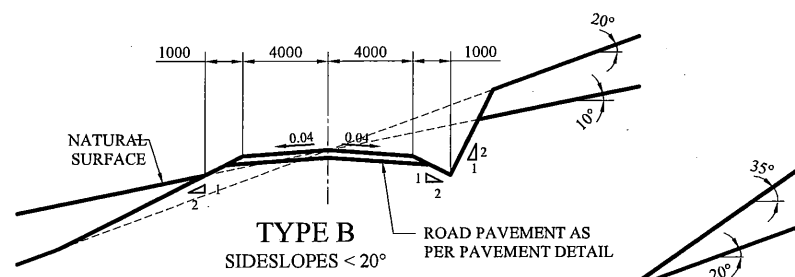
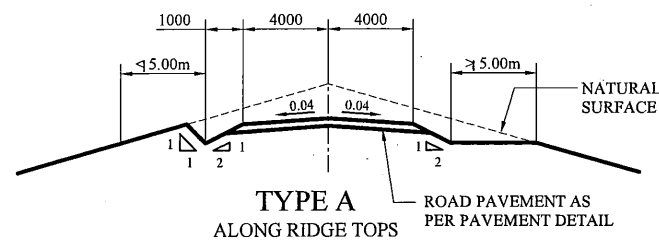

HILLY TO MOUNTAINOUS TERRAIN  
(SIDE CUT - GENERAL)  
NTS

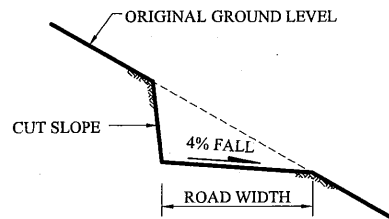

HILLY TO MOUNTAINOUS TERRAIN  
(SIDE CUT - ROCK)  
NTS

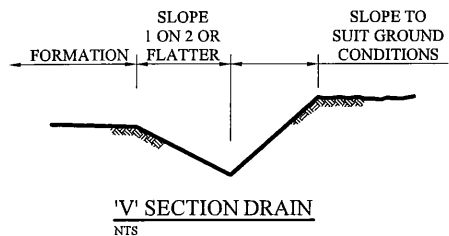

'V' SECTION DRAIN  
NTS

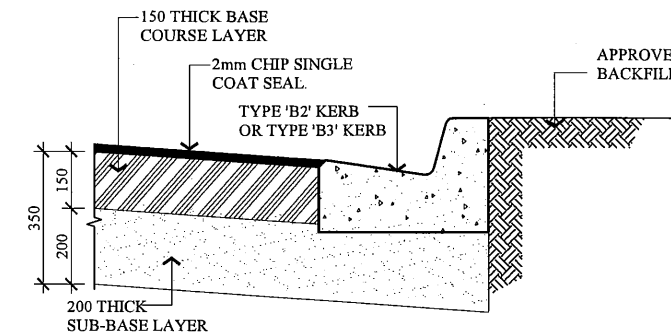

(D1) SUBSURFACE DRAIN (if Required)  
SECTION SCALE 1:20

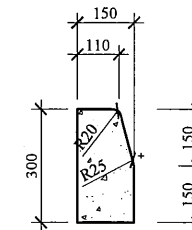

BARRIER KERB - TYPE B1  
SCALE: 1:20

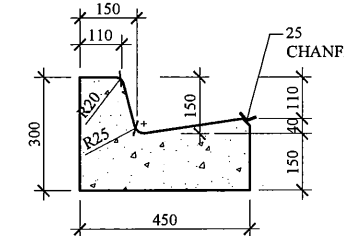

BARRIER KERB - TYPE B2  
SCALE: 1:20

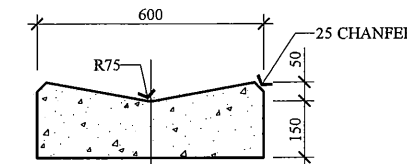

CONCRETE INVERT DRAIN (SD)  
SCALE: 1:20

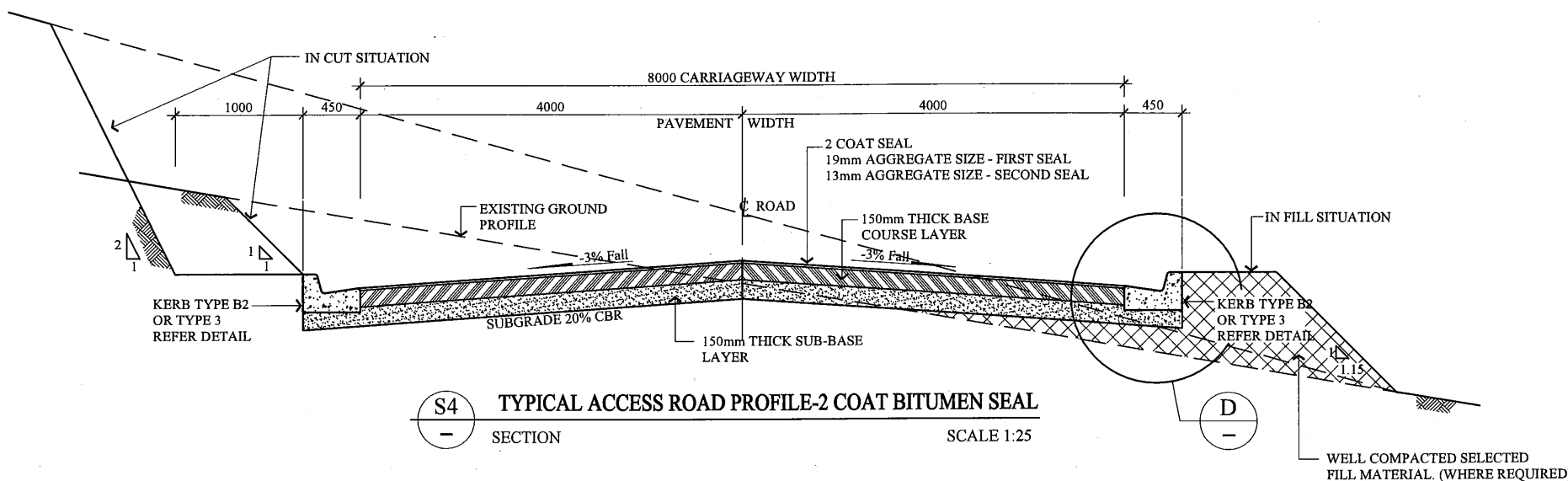

(S4) TYPICAL ACCESS ROAD PROFILE-2 COAT BITUMEN SEAL  
SECTION SCALE 1:25

PROJECT: PORT MORESBY SEWERAGE SYSTEM UPGRADING PROJECT (POMSSUP)

TITLE: KILAKILA STP ACCESS ROAD - Typical Cross Section Profiles

CLIENT: INDEPENDENT PUBLIC BUSINESS CORPORATION  
PORT MORESBY SEWERAGE SYSTEM UPGRADING PROJECT  
PROJECT MANAGEMENT UNIT (PMU)  
jica JAPAN INTERNATIONAL COOPERATION AGENCY

CONSULTANTS: NJS CONSULTANTS CO., LTD. - JAPAN

NOTES:

REVISIONS		
REV.	DATE	DESCRIPTION

APPROVED by PMU: Project Director Lot G.Zaiya	DATE: 1. Dec 2011	SCALE: N.T.S.
CHECKED by CONSULTANT Project Manager T.Fuji	DATE: 1. Dec 2011	DRAWING NO.: STP-KAR-C016

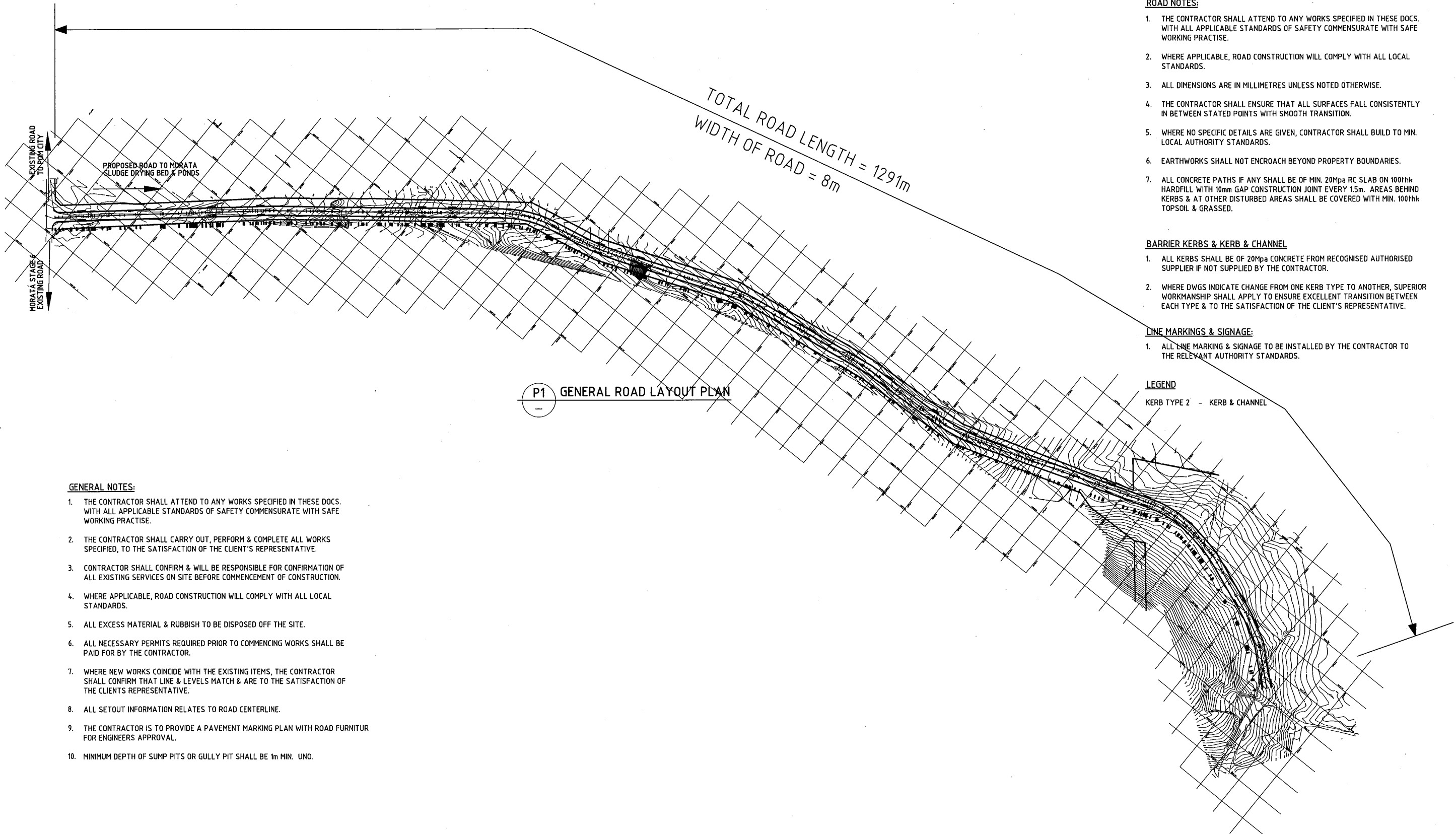

P1 GENERAL ROAD LAYOUT PLAN

- ROAD NOTES:**
1. THE CONTRACTOR SHALL ATTEND TO ANY WORKS SPECIFIED IN THESE DOCS. WITH ALL APPLICABLE STANDARDS OF SAFETY COMMENSURATE WITH SAFE WORKING PRACTISE.
  2. WHERE APPLICABLE, ROAD CONSTRUCTION WILL COMPLY WITH ALL LOCAL STANDARDS.
  3. ALL DIMENSIONS ARE IN MILLIMETRES UNLESS NOTED OTHERWISE.
  4. THE CONTRACTOR SHALL ENSURE THAT ALL SURFACES FALL CONSISTENTLY IN BETWEEN STATED POINTS WITH SMOOTH TRANSITION.
  5. WHERE NO SPECIFIC DETAILS ARE GIVEN, CONTRACTOR SHALL BUILD TO MIN. LOCAL AUTHORITY STANDARDS.
  6. EARTHWORKS SHALL NOT ENCRUCH BEYOND PROPERTY BOUNDARIES.
  7. ALL CONCRETE PATHS IF ANY SHALL BE OF MIN. 20Mpa RC SLAB ON 100thk HARDFILL WITH 10mm GAP CONSTRUCTION JOINT EVERY 1.5m. AREAS BEHIND KERBS & AT OTHER DISTURBED AREAS SHALL BE COVERED WITH MIN. 100thk TOPSOIL & GRASSED.

- BARRIER KERBS & KERB & CHANNEL**
1. ALL KERBS SHALL BE OF 20Mpa CONCRETE FROM RECOGNISED AUTHORISED SUPPLIER IF NOT SUPPLIED BY THE CONTRACTOR.
  2. WHERE DWGS INDICATE CHANGE FROM ONE KERB TYPE TO ANOTHER, SUPERIOR WORKMANSHIP SHALL APPLY TO ENSURE EXCELLENT TRANSITION BETWEEN EACH TYPE & TO THE SATISFACTION OF THE CLIENT'S REPRESENTATIVE.

- LINE MARKINGS & SIGNAGE:**
1. ALL LINE MARKING & SIGNAGE TO BE INSTALLED BY THE CONTRACTOR TO THE RELEVANT AUTHORITY STANDARDS.

**LEGEND**  
KERB TYPE 2 - KERB & CHANNEL

- GENERAL NOTES:**
1. THE CONTRACTOR SHALL ATTEND TO ANY WORKS SPECIFIED IN THESE DOCS. WITH ALL APPLICABLE STANDARDS OF SAFETY COMMENSURATE WITH SAFE WORKING PRACTISE.
  2. THE CONTRACTOR SHALL CARRY OUT, PERFORM & COMPLETE ALL WORKS SPECIFIED, TO THE SATISFACTION OF THE CLIENT'S REPRESENTATIVE.
  3. CONTRACTOR SHALL CONFIRM & WILL BE RESPONSIBLE FOR CONFIRMATION OF ALL EXISTING SERVICES ON SITE BEFORE COMMENCEMENT OF CONSTRUCTION.
  4. WHERE APPLICABLE, ROAD CONSTRUCTION WILL COMPLY WITH ALL LOCAL STANDARDS.
  5. ALL EXCESS MATERIAL & RUBBISH TO BE DISPOSED OFF THE SITE.
  6. ALL NECESSARY PERMITS REQUIRED PRIOR TO COMMENCING WORKS SHALL BE PAID FOR BY THE CONTRACTOR.
  7. WHERE NEW WORKS COINCIDE WITH THE EXISTING ITEMS, THE CONTRACTOR SHALL CONFIRM THAT LINE & LEVELS MATCH & ARE TO THE SATISFACTION OF THE CLIENTS REPRESENTATIVE.
  8. ALL SETOUT INFORMATION RELATES TO ROAD CENTERLINE.
  9. THE CONTRACTOR IS TO PROVIDE A PAVEMENT MARKING PLAN WITH ROAD FURNITUR FOR ENGINEERS APPROVAL.
  10. MINIMUM DEPTH OF SUMP PITS OR GULLY PIT SHALL BE 1m MIN. UNO.

PROJECT: PORT MORESBY SEWERAGE SYSTEM UPGRADING PROJECT (POMSSUP)		TITLE: Morata Access Road - GENERAL ROAD LAYOUT.																				
INDEPENDENT PUBLIC BUSINESS CORPORATION PORT MORESBY SEWERAGE SYSTEM UPGRADING PROJECT PROJECT MANAGEMENT UNIT (PMU)	CONSULTANTS: NJS CONSULTANTS CO., LTD. - JAPAN	NOTES:	<table border="1"> <thead> <tr> <th colspan="3">REVISIONS</th> </tr> <tr> <th>REV.</th> <th>DATE</th> <th>DESCRIPTION</th> </tr> </thead> <tbody> <tr><td> </td><td> </td><td> </td></tr> <tr><td> </td><td> </td><td> </td></tr> <tr><td> </td><td> </td><td> </td></tr> <tr><td> </td><td> </td><td> </td></tr> </tbody> </table>	REVISIONS			REV.	DATE	DESCRIPTION													APPROVED by PMU: Project Director Lot G.Zauya DATE: 1. Dec 2011 SCALE: NTS
		REVISIONS																				
REV.	DATE	DESCRIPTION																				
JAPAN INTERNATIONAL COOPERATION AGENCY		CHECKED by CONSULTANT: Project Manager T.Fuji DATE: 1. Dec 2011 DRAWING NO.: STP-MAR-C001																				

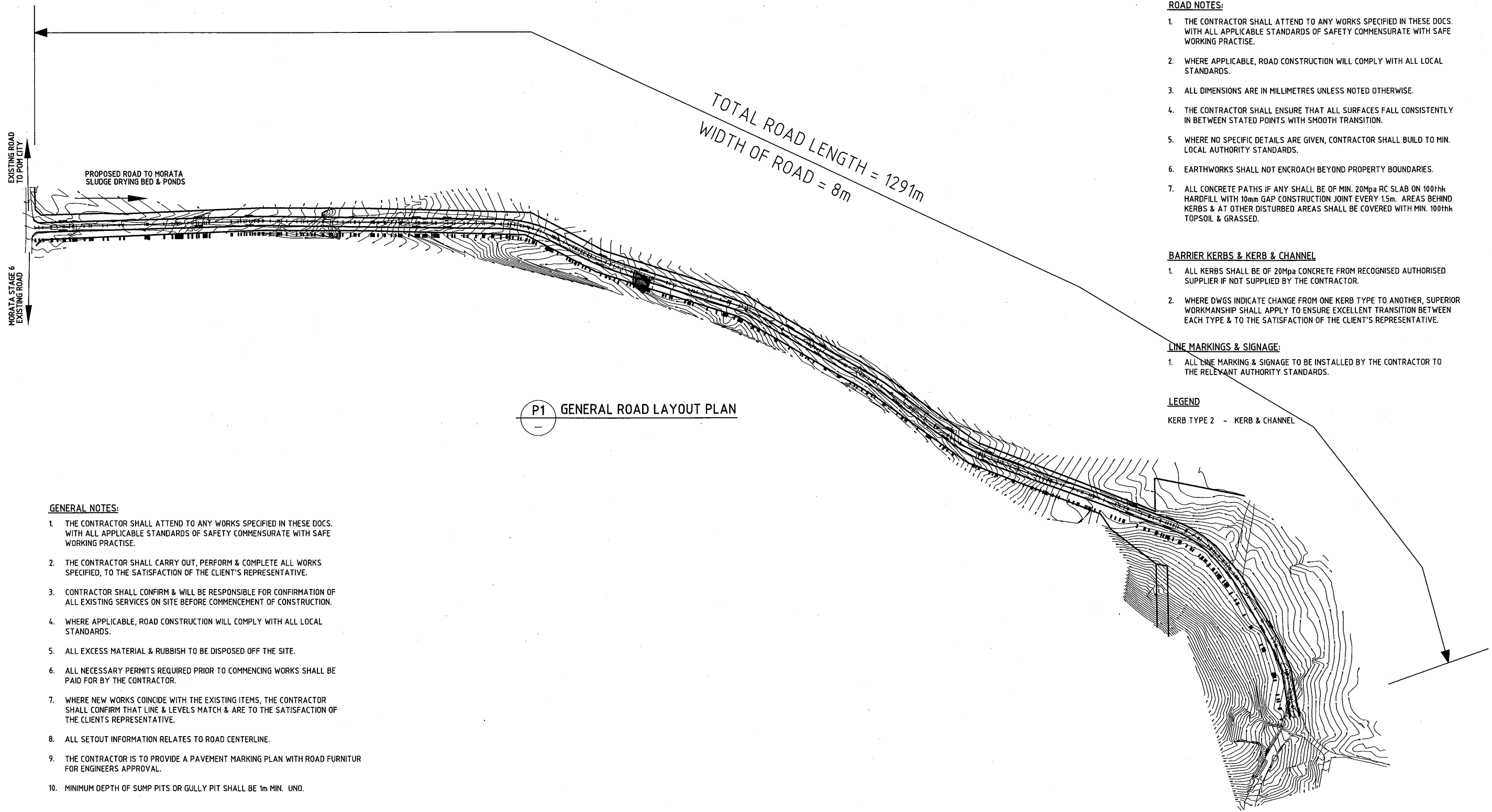

**P1 GENERAL ROAD LAYOUT PLAN**

**ROAD NOTES:**

1. THE CONTRACTOR SHALL ATTEND TO ANY WORKS SPECIFIED IN THESE DOCS. WITH ALL APPLICABLE STANDARDS OF SAFETY COMMENSURATE WITH SAFE WORKING PRACTISE.
2. WHERE APPLICABLE, ROAD CONSTRUCTION WILL COMPLY WITH ALL LOCAL STANDARDS.
3. ALL DIMENSIONS ARE IN MILLIMETRES UNLESS NOTED OTHERWISE.
4. THE CONTRACTOR SHALL ENSURE THAT ALL SURFACES FALL CONSISTENTLY IN BETWEEN STATED POINTS WITH SMOOTH TRANSITION.
5. WHERE NO SPECIFIC DETAILS ARE GIVEN, CONTRACTOR SHALL BUILD TO MIN. LOCAL AUTHORITY STANDARDS.
6. EARTHWORKS SHALL NOT ENCROACH BEYOND PROPERTY BOUNDARIES.
7. ALL CONCRETE PATHS IF ANY SHALL BE OF MIN. 20Mpa RC SLAB ON 100thk HARDFILL WITH 10mm GAP CONSTRUCTION JOINT EVERY 1.5m. AREAS BEHIND KERBS & AT OTHER DISTURBED AREAS SHALL BE COVERED WITH MIN. 100thk TOPSOIL & GRASSED.

**BARRIER KERBS & KERB & CHANNEL**

1. ALL KERBS SHALL BE OF 20Mpa CONCRETE FROM RECOGNISED AUTHORISED SUPPLIER IF NOT SUPPLIED BY THE CONTRACTOR.
2. WHERE DWGS INDICATE CHANGE FROM ONE KERB TYPE TO ANOTHER, SUPERIOR WORKMANSHIP SHALL APPLY TO ENSURE EXCELLENT TRANSITION BETWEEN EACH TYPE & TO THE SATISFACTION OF THE CLIENT'S REPRESENTATIVE.

**LINE MARKINGS & SIGNAGE:**

1. ALL LINE MARKING & SIGNAGE TO BE INSTALLED BY THE CONTRACTOR TO THE RELEVANT AUTHORITY STANDARDS.

**LEGEND**

KERB TYPE 2 - KERB & CHANNEL

**GENERAL NOTES:**

1. THE CONTRACTOR SHALL ATTEND TO ANY WORKS SPECIFIED IN THESE DOCS. WITH ALL APPLICABLE STANDARDS OF SAFETY COMMENSURATE WITH SAFE WORKING PRACTISE.
2. THE CONTRACTOR SHALL CARRY OUT, PERFORM & COMPLETE ALL WORKS SPECIFIED, TO THE SATISFACTION OF THE CLIENT'S REPRESENTATIVE.
3. CONTRACTOR SHALL CONFIRM & WILL BE RESPONSIBLE FOR CONFIRMATION OF ALL EXISTING SERVICES ON SITE BEFORE COMMENCEMENT OF CONSTRUCTION.
4. WHERE APPLICABLE, ROAD CONSTRUCTION WILL COMPLY WITH ALL LOCAL STANDARDS.
5. ALL EXCESS MATERIAL & RUBBISH TO BE DISPOSED OFF THE SITE.
6. ALL NECESSARY PERMITS REQUIRED PRIOR TO COMMENCING WORKS SHALL BE PAID FOR BY THE CONTRACTOR.
7. WHERE NEW WORKS COINCIDE WITH THE EXISTING ITEMS, THE CONTRACTOR SHALL CONFIRM THAT LINE & LEVELS MATCH & ARE TO THE SATISFACTION OF THE CLIENTS REPRESENTATIVE.
8. ALL SETOUT INFORMATION RELATES TO ROAD CENTERLINE.
9. THE CONTRACTOR IS TO PROVIDE A PAVEMENT MARKING PLAN WITH ROAD FURNITUR FOR ENGINEERS APPROVAL.
10. MINIMUM DEPTH OF SUMP PITS OR GULLY PIT SHALL BE 1m MIN. UNO.

PROJECT: <b>PORT MORESBY SEWERAGE SYSTEM UPGRADING PROJECT (POMSSUP)</b>		TITLE: <b>Morata Access Road - GENERAL ROAD LAYOUT.</b>																			
<b>INDEPENDENT PUBLIC BUSINESS CORPORATION</b> PORT MORESBY SEWERAGE SYSTEM UPGRADING PROJECT PROJECT MANAGEMENT UNIT (PMU)	CONSULTANTS: <b>NJS CONSULTANTS CO., LTD. - JAPAN</b>	APPROVED by PMU: Project Director Lot G.Zaiya	DATE: 1. Dec 2011 SCALE: NTS																		
<b>JAPAN INTERNATIONAL COOPERATION AGENCY</b>	NOTES:	CHECKED by CONSULTANT Project Manager T.Fuji	DATE: 1. Dec 2011 DRAWING NO.: <b>STP-MAR-C001</b>																		
		<table border="1" style="width: 100%; border-collapse: collapse;"> <thead> <tr> <th colspan="3">REVISIONS</th> </tr> <tr> <th style="width: 10%;">REV</th> <th style="width: 10%;">DATE</th> <th style="width: 80%;">DESCRIPTION</th> </tr> </thead> <tbody> <tr><td> </td><td> </td><td> </td></tr> <tr><td> </td><td> </td><td> </td></tr> <tr><td> </td><td> </td><td> </td></tr> <tr><td> </td><td> </td><td> </td></tr> </tbody> </table>		REVISIONS			REV	DATE	DESCRIPTION												
REVISIONS																					
REV	DATE	DESCRIPTION																			

MORATA ACCESS ROAD ALIGNMENT DETAILS

Chainage	Easting	Northing	Radius	TanLngth	Def Angle	Bearing
0.000	108859.876	113391.120			319°14'36"	Straight
25.000	108843.554	113410.057			319°14'36"	Straight
50.000	108827.233	113428.995			319°14'36"	Straight
75.000	108810.912	113447.932			319°14'36"	Straight
92.932	108799.205	113461.515			319°14'36"	Straight
100.000	108794.591	113466.869			319°14'36"	Straight
125.000	108778.270	113485.806			319°14'36"	Straight
134.389	108772.140	113492.919			319°14'36"	Straight
150.000	108761.948	113504.744			319°14'36"	Straight
153.106	108759.921	113507.096			319°14'36"	Straight
175.000	108745.627	113523.681			319°14'36"	Straight
200.000	108729.306	113542.618			319°14'36"	Straight
203.293	108727.156	113545.113			319°14'36"	Straight
203.293	108727.156	113545.113			319°14'36"	Straight
225.000	108713.721	113562.162			321°45'45"	Straight
250.000	108698.248	113581.799			321°45'45"	Straight
275.000	108682.775	113601.435			321°45'45"	Straight
284.064	108677.165	113608.554			321°45'45"	Straight
300.000	108667.302	113621.071			321°45'45"	Straight
325.000	108651.829	113640.707			321°45'45"	Straight
350.000	108636.356	113660.344			321°45'45"	Straight
375.000	108620.883	113679.980			321°45'45"	Straight
400.000	108605.410	113699.616			321°45'45"	Straight
411.946	108598.016	113709.000			321°45'45"	Straight
416.242	108595.357	113712.373			321°45'45"	Straight
416.242	108595.357	113712.373	104.975	25.000	26°47'28"	321°45'45" Arc
425.000	108590.230	113719.471	104.975	25.000	26°47'28"	326°32'34" Arc
449.394	108579.256	113741.195	104.975	25.000	26°47'28"	339°51'25" Arc
450.000	108579.049	113741.765	104.975	25.000	26°47'28"	340°11'16" Arc
465.327	108574.923	113756.513	104.975	25.000	26°47'28"	348°33'13" Arc
465.327	108574.923	113756.513			348°33'13"	Straight
471.637	108573.671	113762.697			348°33'13"	Straight
475.000	108573.003	113765.993			348°33'13"	Straight
493.180	108569.396	113783.811			348°33'13"	Straight
493.180	108569.396	113783.811	227.473	20.000	10°02'58"	348°33'13" Arc
500.000	108567.942	113790.474	227.473	20.000	10°02'58"	346°50'09" Arc
516.857	108563.499	113806.731	227.473	20.000	10°02'58"	342°35'24" Arc
525.000	108560.924	113814.456	227.473	20.000	10°02'58"	340°32'19" Arc
532.680	108558.243	113821.652	227.473	20.000	10°02'58"	338°36'16" Arc
533.077	108558.098	113822.022	227.473	20.000	10°02'58"	338°30'15" Arc
533.077	108558.098	113822.022			338°30'15"	Straight
550.000	108551.897	113837.768			338°30'15"	Straight
575.000	108542.736	113861.029			338°30'15"	Straight
586.235	108538.619	113871.483			338°30'15"	Straight
600.000	108533.575	113884.290			338°30'15"	Straight
625.000	108524.415	113907.551			338°30'15"	Straight
632.043	108521.834	113914.105			338°30'15"	Straight
632.043	108521.834	113914.105	139.008	15.000	12°19'03"	338°30'15" Arc
637.985	108519.775	113919.677	139.008	15.000	12°19'03"	340°57'11" Arc
650.000	108516.350	113931.190	139.008	15.000	12°19'03"	345°54'20" Arc
661.928	108513.945	113942.869	139.008	15.000	12°19'03"	350°49'19" Arc

MORATA ACCESS ROAD ALIGNMENT DETAILS

Chainage	Easting	Northing	Radius	TanLngth	Def Angle	Bearing
661.928	108513.945	113942.869			350°49'19"	Straight
663.417	108513.707	113944.339			350°49'19"	Straight
675.000	108511.859	113955.774			350°49'19"	Straight
700.000	108507.872	113980.454			350°49'19"	Straight
725.000	108503.884	114005.134			350°49'19"	Straight
750.000	108499.897	114029.814			350°49'19"	Straight
775.000	108495.909	114054.494			350°49'19"	Straight
785.056	108494.305	114064.421			350°49'19"	Straight
788.204	108493.803	114067.529			350°49'19"	Straight
788.204	108493.803	114067.529			350°49'19"	Straight
800.000	108493.205	114079.310			357°05'36"	Straight
825.000	108491.937	114104.277			357°05'36"	Straight
850.000	108490.669	114129.245			357°05'36"	Straight
865.615	108489.878	114144.840			357°05'36"	Straight
865.615	108489.878	114144.840	176.525	25.000	16°07'18"	357°05'36" Arc
875.000	108489.153	114154.196	176.525	25.000	16°07'18"	354°02'50" Arc
879.394	108488.643	114158.561	176.525	25.000	16°07'18"	352°37'15" Arc
900.000	108484.811	114178.795	176.525	25.000	16°07'18"	345°55'58" Arc
915.284	108480.459	114193.442	176.525	25.000	16°07'18"	340°58'19" Arc
915.284	108480.459	114193.442			340°58'19"	Straight
925.000	108477.292	114202.626			340°58'19"	Straight
950.000	108469.141	114226.260			340°58'19"	Straight
955.178	108467.452	114231.156			340°58'19"	Straight
973.181	108461.583	114248.175			340°58'19"	Straight
975.000	108460.990	114249.894			340°58'19"	Straight
1000.000	108452.839	114273.528			340°58'19"	Straight
1014.455	108448.127	114287.193			340°58'19"	Straight
1025.000	108444.688	114297.162			340°58'19"	Straight
1050.000	108436.538	114320.796			340°58'19"	Straight
1075.000	108428.387	114344.430			340°58'19"	Straight
1080.340	108426.646	114349.479			340°58'19"	Straight
1080.340	108426.646	114349.479	98.637	25.000	28°26'41"	340°58'19" Arc
1100.000	108422.124	114368.578	98.637	25.000	28°26'41"	352°23'30" Arc
1125.000	108421.973	114393.511	98.637	25.000	28°26'41"	6°54'49" Arc
1129.309	108422.585	114397.776	98.637	25.000	28°26'41"	9°25'00" Arc
1129.309	108422.585	114397.776			9°25'00"	Straight
1144.028	108424.993	114412.296			9°25'00"	Straight
1144.028	108424.993	114412.296	98.132	10.000	11°38'14"	9°25'00" Arc
1150.000	108426.149	114418.155	98.132	10.000	11°38'14"	12°54'14" Arc
1163.959	108430.222	114431.494	98.132	10.000	11°38'14"	21°03'14" Arc
1163.959	108430.222	114431.494			21°03'14"	Straight
1175.000	108434.188	114441.798			21°03'14"	Straight
1200.000	108443.170	114465.129			21°03'14"	Straight
1220.970	108450.703	114484.699			21°03'14"	Straight
1220.970	108450.703	114484.699			21°03'14"	Straight
1225.000	108452.589	114488.261			27°53'58"	Straight
1248.064	108463.381	114508.644			27°53'58"	Straight
1248.064	108463.381	114508.644			27°53'58"	Straight
1250.000	108464.653	114510.103			41°04'34"	Straight
1275.000	108481.080	114528.949			41°04'34"	Straight
1291.057	108491.630	114541.053			41°04'34"	Straight

PROJECT: PORT MORESBY SEWERAGE SYSTEM UPGRADING PROJECT (POMSSUP)

TITLE: Morata Access Road - ROAD CENTER LINE SET OUT DETAILS.



INDEPENDENT PUBLIC BUSINESS CORPORATION  
PORT MORESBY SEWERAGE SYSTEM UPGRADING PROJECT  
PROJECT MANAGEMENT UNIT (PMU)

CONSULTANTS:



NJS CONSULTANTS CO., LTD. - JAPAN

NOTES:

REVISIONS		
REV.	DATE	DESCRIPTION

APPROVED by PMU:	Project Director Lot G.Zauya	DATE: 1. Dec 2011	SCALE: NTS
CHECKED by CONSULTANT	Project Manager T.Fuji	DATE: 1. Dec 2011	DRAWING NO.: STP-MAR-C002



JAPAN INTERNATIONAL COOPERATION AGENCY



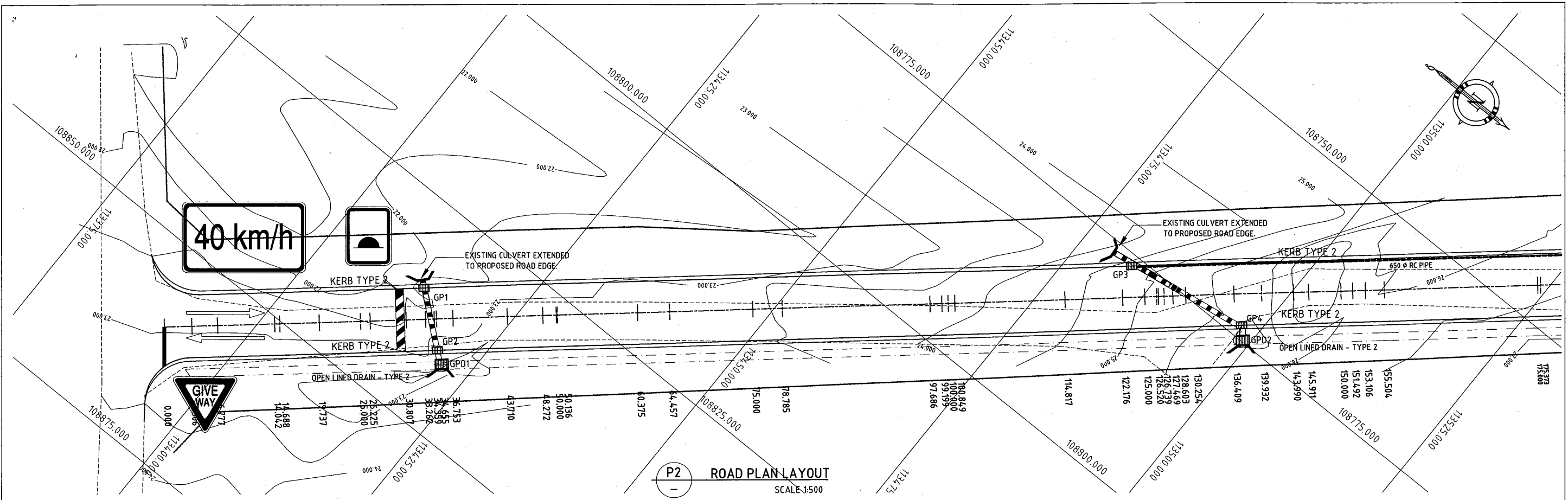

**P2 ROAD PLAN LAYOUT**  
SCALE: 1:500

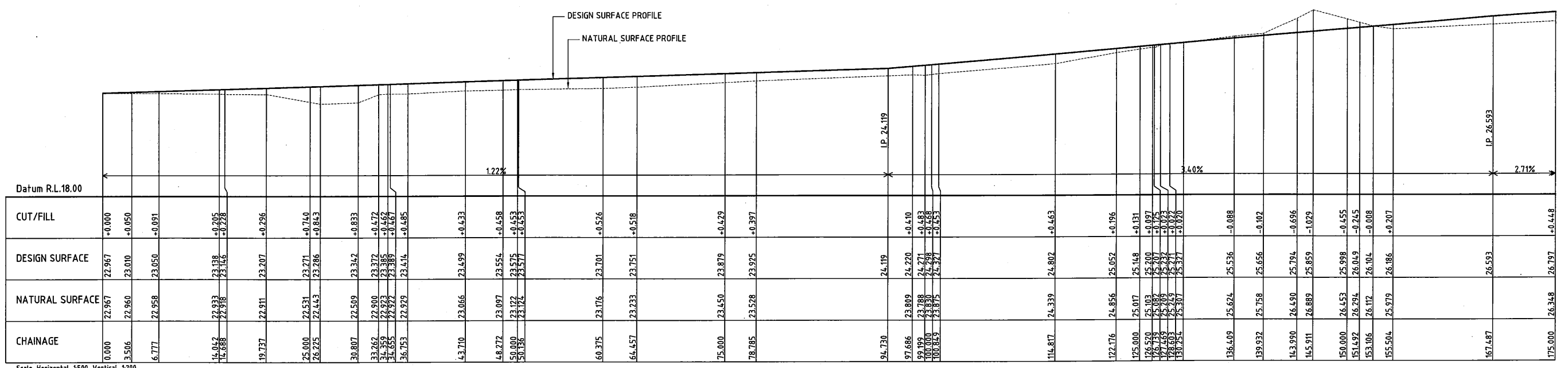

**S1 LONGITUDINAL SECT (CH 0.00 - CH 175.00)**  
SECTION  
SCALE HOR. 1:500  
VERT. 1:250

<b>PROJECT:</b> PORT MORESBY SEWERAGE SYSTEM UPGRADING PROJECT (POMSSUP)		<b>TITLE:</b> Morata Access Road - PLAN & LONG SECTION 1.																
<b>INDEPENDENT PUBLIC BUSINESS CORPORATION</b> PORT MORESBY SEWERAGE SYSTEM UPGRADING PROJECT PROJECT MANAGEMENT UNIT (PMU)	<b>CONSULTANTS:</b> <b>NJS CONSULTANTS CO., LTD. - JAPAN</b>	<b>NOTES:</b>	<table border="1" style="width:100%; border-collapse: collapse;"> <thead> <tr> <th colspan="3">REVISIONS</th> </tr> <tr> <th>REV.</th> <th>DATE</th> <th>DESCRIPTION</th> </tr> </thead> <tbody> <tr><td> </td><td> </td><td> </td></tr> <tr><td> </td><td> </td><td> </td></tr> <tr><td> </td><td> </td><td> </td></tr> </tbody> </table>	REVISIONS			REV.	DATE	DESCRIPTION									
REVISIONS																		
REV.	DATE	DESCRIPTION																
<b>JAPAN INTERNATIONAL COOPERATION AGENCY</b>		<table border="1" style="width:100%; border-collapse: collapse;"> <tr> <td style="width:50%;"><b>APPROVED by PMU:</b></td> <td style="width:50%;"><b>Project Director</b> Lot G.Zauya</td> </tr> <tr> <td style="width:50%;"><b>CHECKED by CONSULTANT</b></td> <td style="width:50%;"><b>Project Manager</b> T.Fuji</td> </tr> </table>	<b>APPROVED by PMU:</b>	<b>Project Director</b> Lot G.Zauya	<b>CHECKED by CONSULTANT</b>	<b>Project Manager</b> T.Fuji	<table border="1" style="width:100%; border-collapse: collapse;"> <tr> <td style="width:50%;"><b>DATE:</b> 1. Dec 2011</td> <td style="width:50%;"><b>SCALE:</b> AS SHOWN</td> </tr> <tr> <td style="width:50%;"><b>DATE:</b> 1. Dec 2011</td> <td style="width:50%;"><b>DRAWING NO.:</b> STP-MAR-C003</td> </tr> </table>	<b>DATE:</b> 1. Dec 2011	<b>SCALE:</b> AS SHOWN	<b>DATE:</b> 1. Dec 2011	<b>DRAWING NO.:</b> STP-MAR-C003							
<b>APPROVED by PMU:</b>	<b>Project Director</b> Lot G.Zauya																	
<b>CHECKED by CONSULTANT</b>	<b>Project Manager</b> T.Fuji																	
<b>DATE:</b> 1. Dec 2011	<b>SCALE:</b> AS SHOWN																	
<b>DATE:</b> 1. Dec 2011	<b>DRAWING NO.:</b> STP-MAR-C003																	

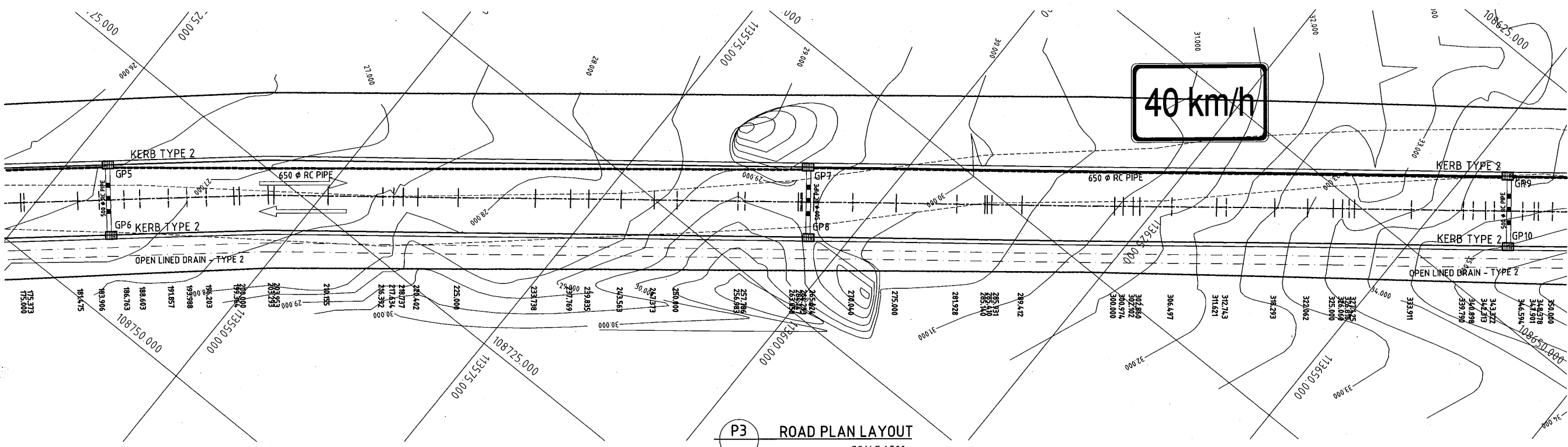

**P3 ROAD PLAN LAYOUT**  
SCALE 1:500

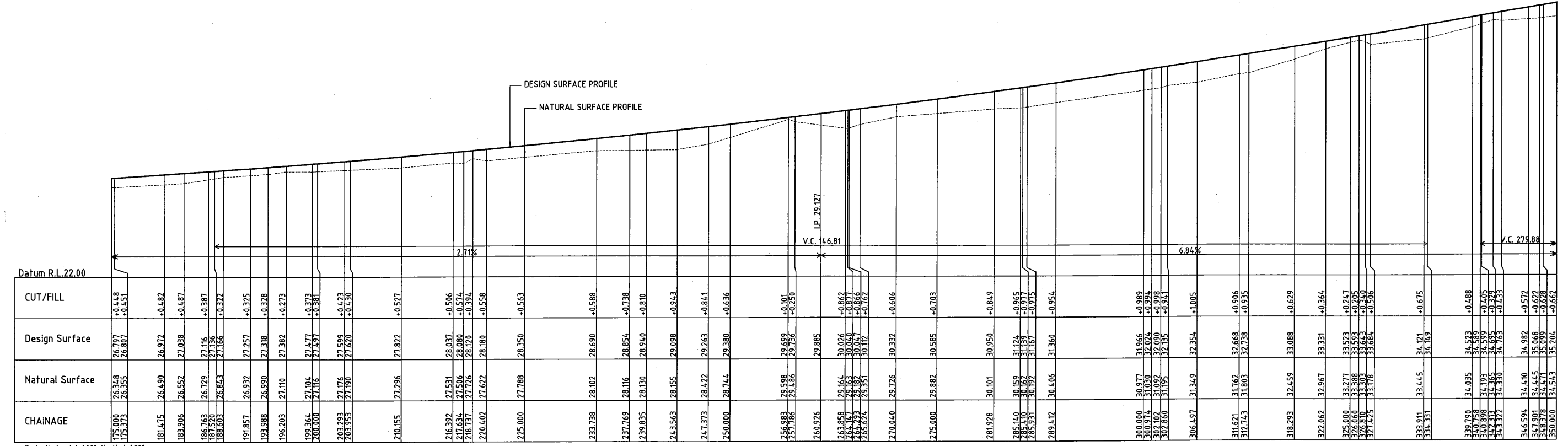

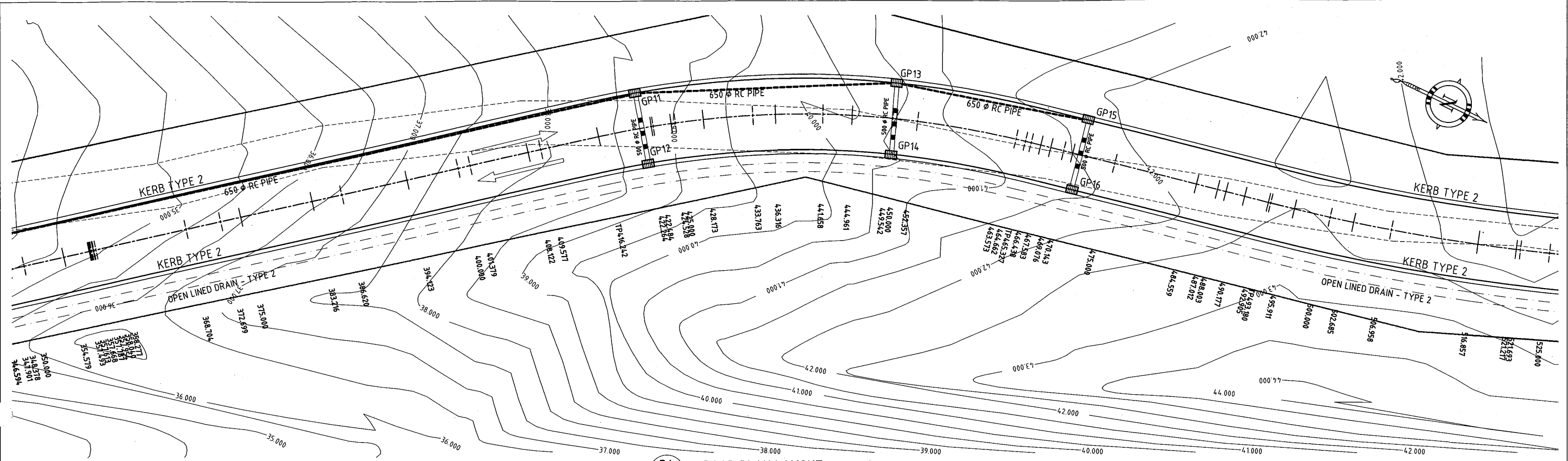

**P4 ROAD PLAN LAYOUT**  
SCALE 1:500

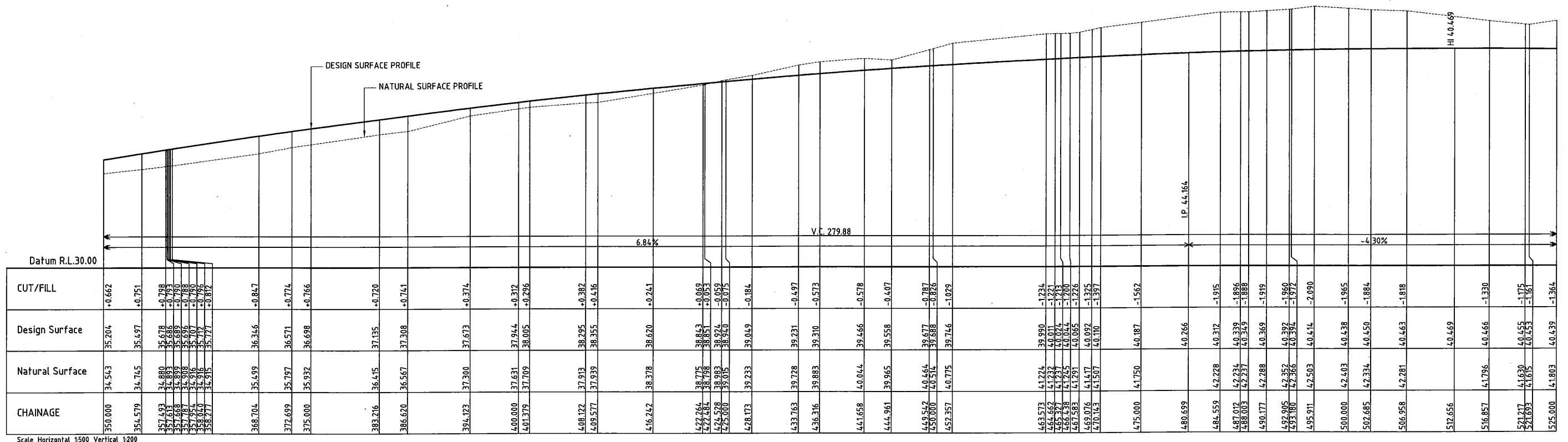

**S3 LONGITUDINAL SECT (CH 350.00 - CH 525.00)**  
SCALE HOR. 1:500  
VERT. 1:250

PROJECT: PORT MORESBY SEWERAGE SYSTEM UPGRADING PROJECT (POMSSUP) TITLE: Morata Access Road - PLAN & LONG SECTION 3.

INDEPENDENT PUBLIC BUSINESS CORPORATION  
PORT MORESBY SEWERAGE SYSTEM UPGRADING PROJECT  
PROJECT MANAGEMENT UNIT (PMU)  
JICA JAPAN INTERNATIONAL COOPERATION AGENCY

CONSULTANTS: NJS CONSULTANTS CO., LTD. - JAPAN

NOTES:

REVISIONS			APPROVED by PMU:	Project Director	DATE:	SCALE:
REV.	DATE	DESCRIPTION	Lot G.Zauya		1. Dec 2011	AS SHOWN

CHECKED by CONSULTANT: Project Manager T.Fuji DATE: 1. Dec 2011 DRAWING NO.: STP-MAR-C005

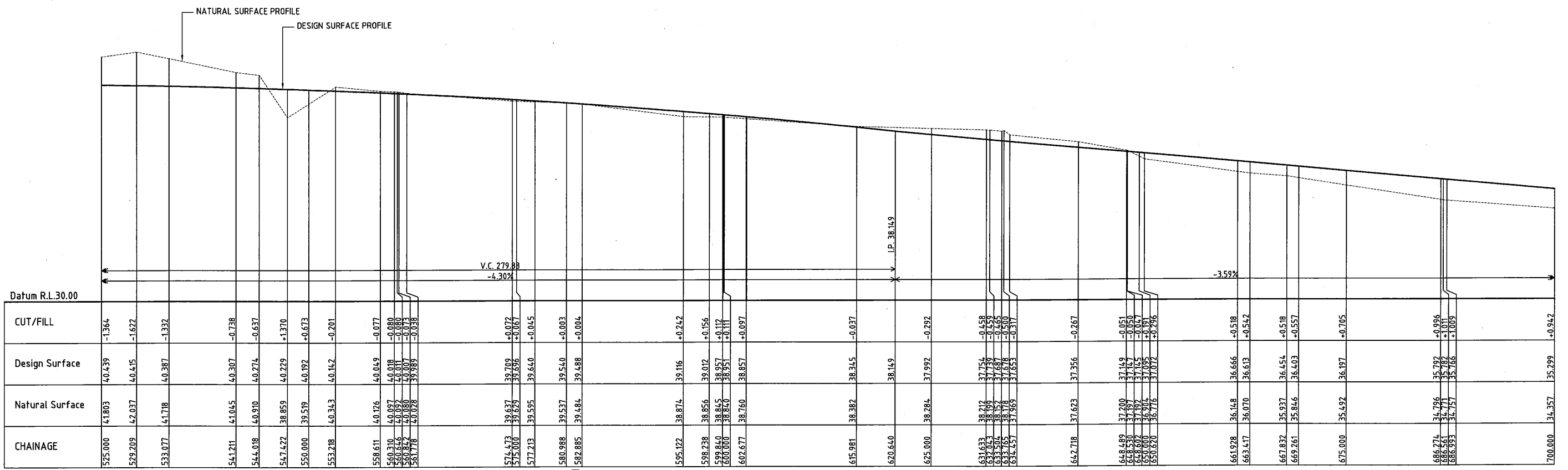
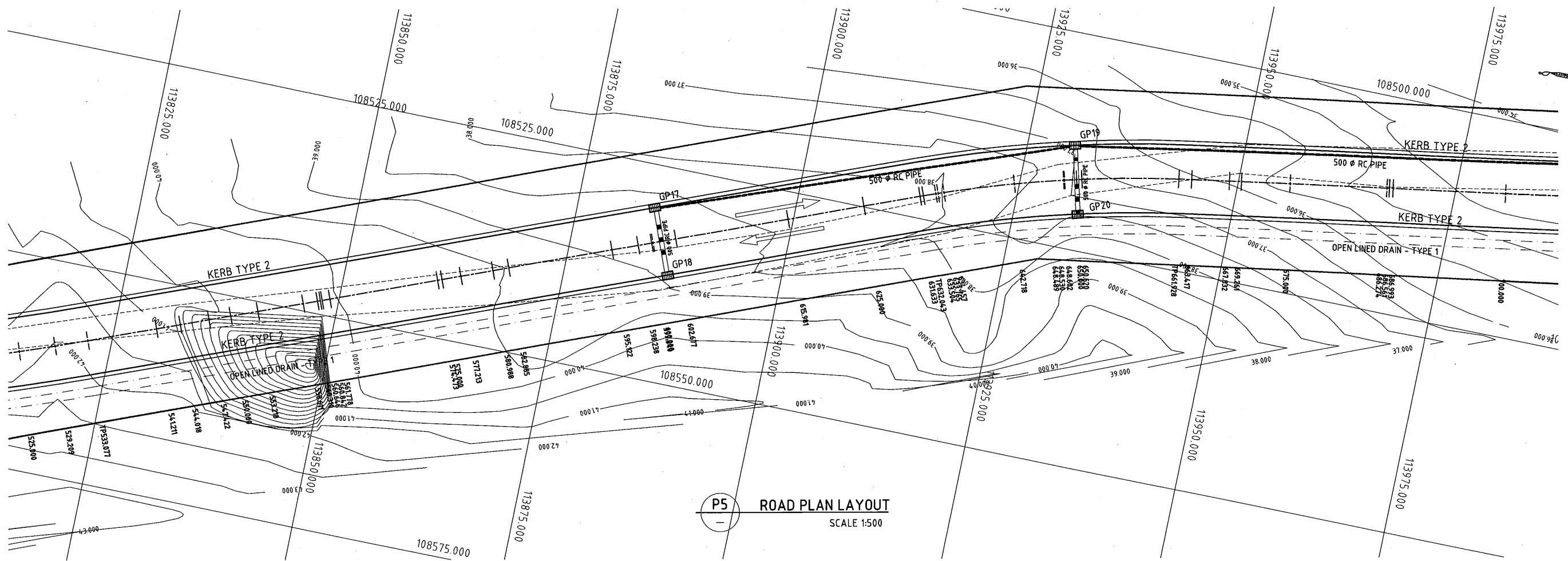

**S4 LONGITUDINAL SECT (CH 525.00 - CH 700.00)**  
SECTION SCALE HOR. 1:500 VERT. 1:250

PROJECT: <b>PORT MORESBY SEWERAGE SYSTEM UPGRADING PROJECT (POMSSUP)</b>		TITLE: <b>Morata Access Road - PLAN &amp; LONG SECTION 4.</b>	
INDEPENDENT PUBLIC BUSINESS CORPORATION PORT MORESBY SEWERAGE SYSTEM UPGRADING PROJECT PROJECT MANAGEMENT UNIT (PMU)	CONSULTANTS: NJS CONSULTANTS CO., LTD. - JAPAN	APPROVED by PMU: Project Director Lot G.Zauya	DATE: <b>1. Dec 2011</b> SCALE: <b>AS SHOWN</b>
JAPAN INTERNATIONAL COOPERATION AGENCY	NOTES:	CHECKED by CONSULTANT: Project Manager T.Fuji	DATE: <b>1. Dec 2011</b> DRAWING NO.: <b>STP-MAR-C006</b>

