

Brazil  
Santa Catarina State

**PREPARATORY SURVEY  
FOR  
THE PROJECT ON DISASTER PREVENTION  
AND  
MITIGATION MEASURES FOR THE ITAJAI RIVER  
BASIN**

**FINAL REPORT**

**VOLUME I : EXECUTIVE SUMMARY**

**NOVEMBER 2011**

**JAPAN INTERNATIONAL COOPERATION AGENCY**

---

**NIPPON KOEI CO., LTD**

GED
JR(先)
11-179

Brazil  
Santa Catarina State

**PREPARATORY SURVEY  
FOR  
THE PROJECT ON DISASTER PREVENTION  
AND  
MITIGATION MEASURES FOR THE ITAJAI RIVER  
BASIN**

**FINAL REPORT**

**VOLUME I : EXECUTIVE SUMMARY**

**NOVEMBER 2011**

**JAPAN INTERNATIONAL COOPERATION AGENCY**

---

**NIPPON KOEI CO., LTD**

# FINAL REPORT

## Composition of Reports

VOLUME I	EXECUTIVE SUMMARY
VOLUME II	MAIN REPORT Part I : Master Plan Study Part II : Feasibility Study
VOLUME III	SUPPORTING REPORT (A) Hydrology (B) Flood Mitigation Plan (C) Natural Condition and Landslide Management Plan (D) Flood Forecasting and Warning System (E) Water Storage in Paddy Fields (F) Environmental and Social Considerations (G) Structural Design and Cost Estimate (H) Economic Evaluation
VOLUME IV	DATA BOOK CD

### EXCHANGE RATE

The exchange rate used in this Study is:	
Master Plan (2010/10)	Brazilian Real (R\$1.0 )=US Dollar (US\$0.58 ) = Japanese Yen(Y47.87)
Feasibility Study(2011/06)	Brazilian Real (R\$1.0 )=US Dollar (US\$0.63 ) = Japanese Yen(Y50.71)



# Master Plan of Flood Management for Itajai River Basin

## Characteristics of the flood disasters in the Itajai River basin

Urban areas are developed over flood plain and houses are close to the river. This might cause frequent inundation and restriction of flow capacity of the river.

Urban areas extending to mountainous area, where are used as mainly pastures. This might increase peak discharge such as flash floods and sediment-related disasters.



## Flood Prevention and Mitigation Measures for Safety Level of 50-year Flood

Project Components	Location	Amount	Project Cost (R\$ 10 <sup>3</sup> )	Priority for F/S
Water storage in rice field	All the basin	22,000ha	33,000	○
Heightening existing flood control dams	Taio, Ituporanga	2 dams	33,000	○
Basin storage (small dams)	Upstream area of Rio do Sul	7 locations	211,000	○
Flood Gates	Itajai (Itajai Mirim River)	2 gates	94,000	○
Floodway	Itajai, Navegantes ( Itajai River)	10.9 km	593,000	
New flood control dam	Brusque	1 dam	95,000	
River improvement (widening, dyke)	Taio	3.7 km	114,000	
River improvement (dyke)	Rio do Sul	8.2 km	268,000	
River improvement (dyke)	Timbo	1.0 km	22,000	
Composite section with APP	Blumenau (Itajai River)	15.8 km	267,000	
River improvement (widening)	Blumenau (Garcia, Velha River)	7.0 km	196,000	
Ring dyke	Ilhota	8.0 km	70,000	
Modification of operation of existing hydropower dams	Rio dos Cedros	2 dams	-	○
Strengthening existing FFWS	All the basin	-	4,000	○

## Structural Measures



## Non-Structural Measures : Strengthening of Existing FFWS

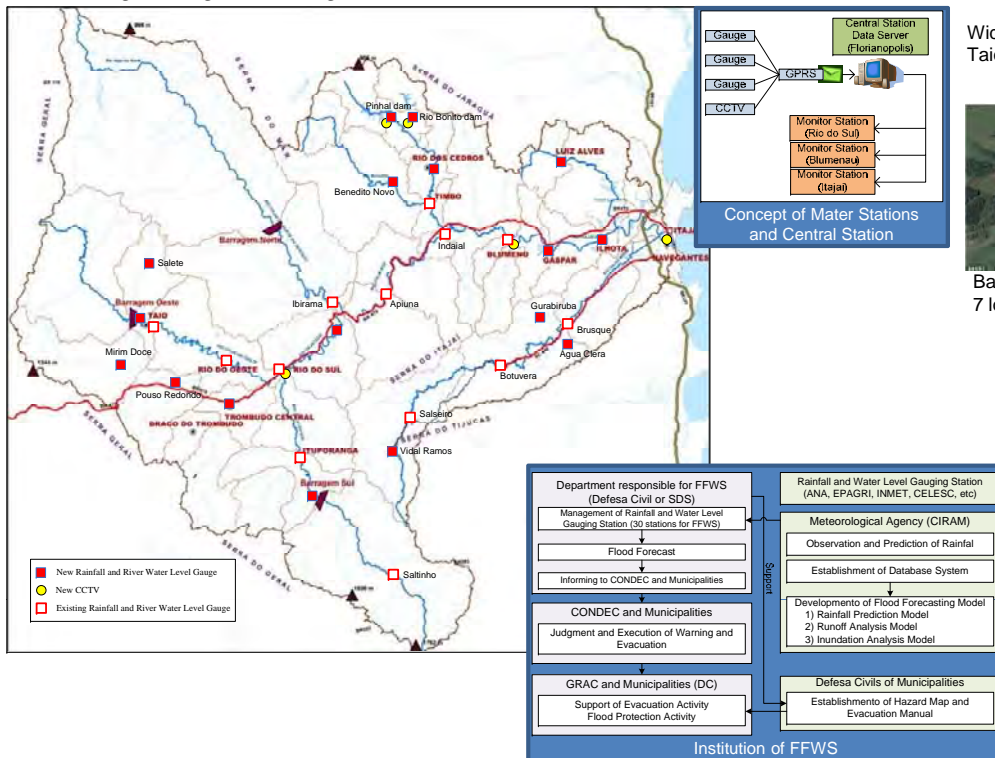

Heightening of Oeste Dam (Heightening by 2.0 m)

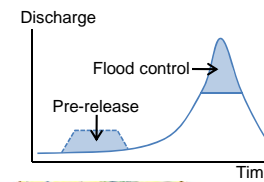

Modification of operation of existing hydropower dams



Composite section with APP Blumenau L=15.8 km

Widening, Dyke Taio L=3.7 km



Basin storage (small dams) 7 locations



Heightening of Spillway of Sul Dam (Heightening by 2.0 m)

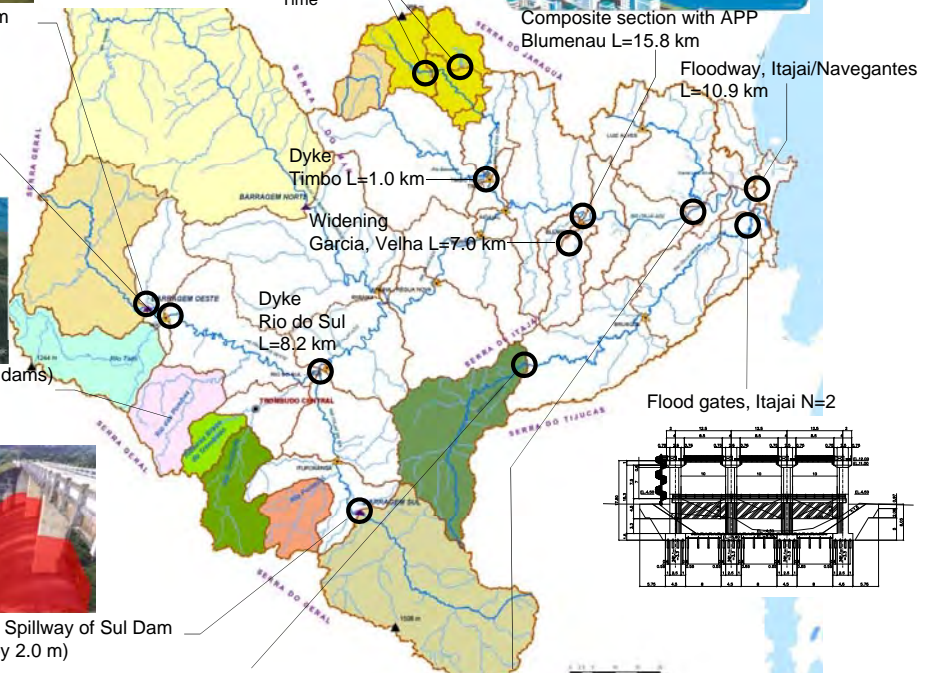

New flood control dam, Brusque

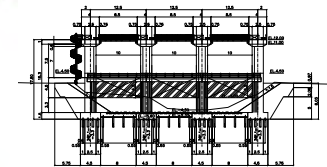

Flood gates, Itajai N=2



# Master Plan of Landslide Management for Itajai River Basin

## Result of the Risk Assessment

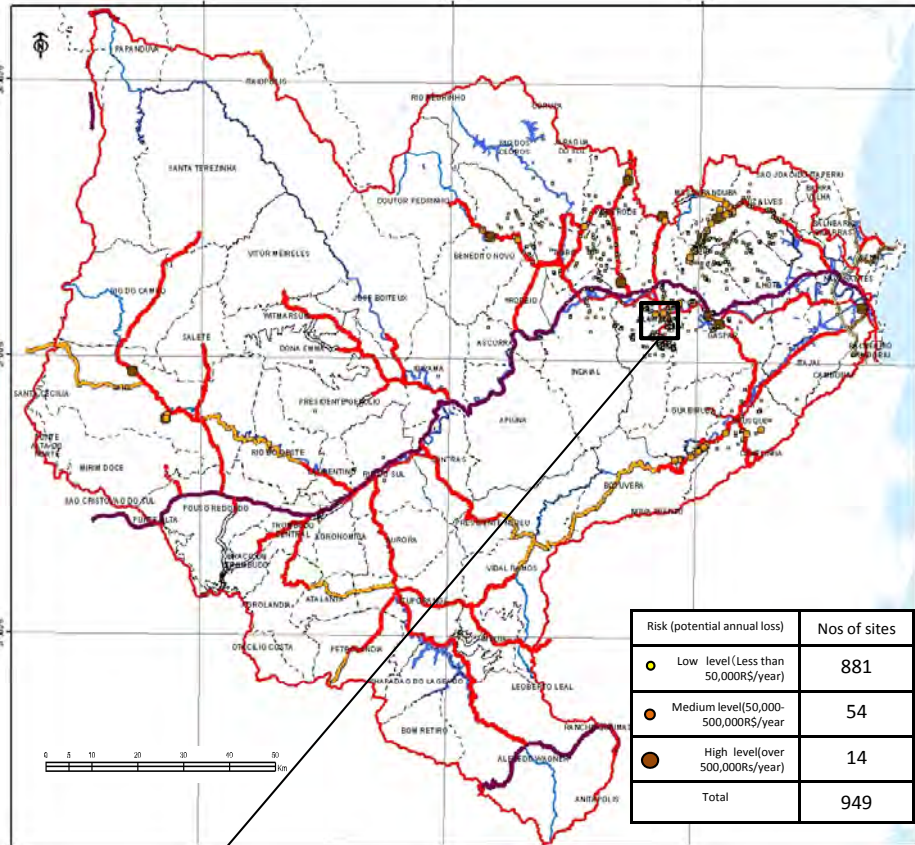

Example of landslide risk map

- Legend**
- Road**
- Federal paved roads, two lanes each way
  - Federal paved roads
  - State paved roads, two lanes each way
  - State paved road
  - State unpaved roads gravel base
  - State unpaved roads natural
  - Municipality paved roads
  - Municipality unpaved roads
- Boundary**
- Itajai Basin
  - Municipality
  - Drainage
  - Basin

## Components of Landslide Management Master Plan

Purpose	Measures	Project Cost Unit : R\$×10 <sup>3</sup>
Avoidance of human lives loss	(1) Non-structural measures a) Formulation of Early warning system for Landslide/Flash flood. b) Disaster education	4,000
Reducing economic losses	(2) Structural measures for landslide Structural measures from the priority sites which have high potential annual loss.	13 High Risk landslide 19,000 54 Medium Risk landslide 35,000 Total 54,000
	(3) Sediment yield mitigation by forestation. Forestation of bare collapsed land, prevention of river-bank erosion by river bank forest will be promoted. Prevention of sediment yield will be secured by vegetation at structural measures sites for landslide.	—
	(4) Flash flood/Flood mitigation by discharge regulation facilities Installation of discharge regulation facilities for rainfall runoff.	—
	(5) Capacity building for structural measure and support for private self-reliant effort a) Capacity building for structural measure project b) Support for private self-reliant effort of structural measures by subsidy.	—

## Structural measures for landslide

Safety level: to ensure half functionality of infrastructures and/or building/lands against heavy rain of 60 years return period, (heavy rain level in Nov 2008 at Blumeau City)

Areas of high possibility disaster occurrence on main infrastructure. (67 sites)  
32 SC road slopes, and 35 Municipality road slopes



## Non-structural measures

### Early warning system for Landslide/ flash flood

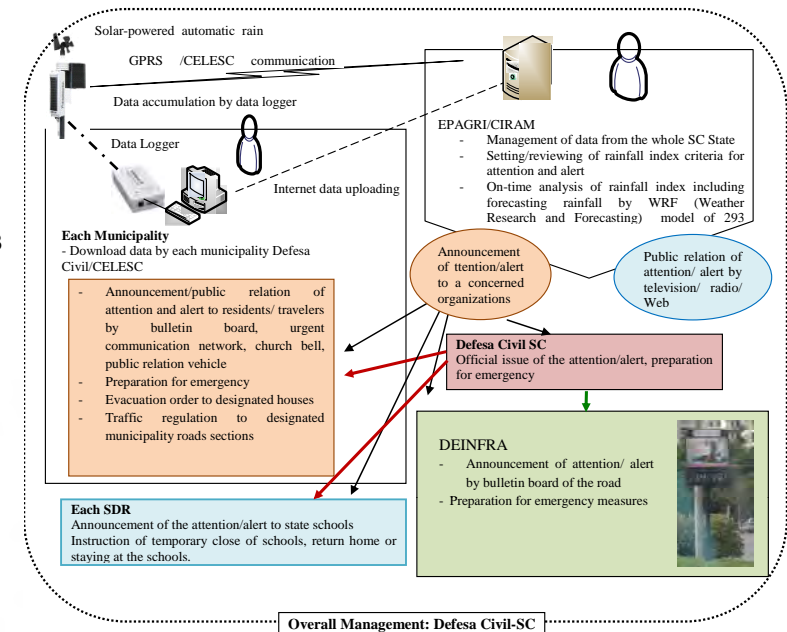

# Feasibility Study of Priority Projects for Flood Prevention and Mitigation

## SELECTION PRIORITY PROJECT

To achieve the 50-year flood safety level, a lot of cost and long period of implementation will be necessary. It is important to implement step-wise gradually increasing safety level with priority projects including the non-structural measures. The 10-year flood level might be recommended for the target safety level of the first phase, considering the budget of the State Government. The priority flood prevention and mitigation measures for feasibility study were selected as follows:

- Water storage in paddy fields
- Heightening of existing flood control dam and modification of operation (2 dams)
- Utilization of existing hydropower dams for flood control (2 dams)
- Strengthening existing flood forecasting and warning system (FFWS)
- Installation of floodgates and improving Itajai Mirim River in Itajai city

## Heightening of Existing Flood Control Dams and Modification of Operation

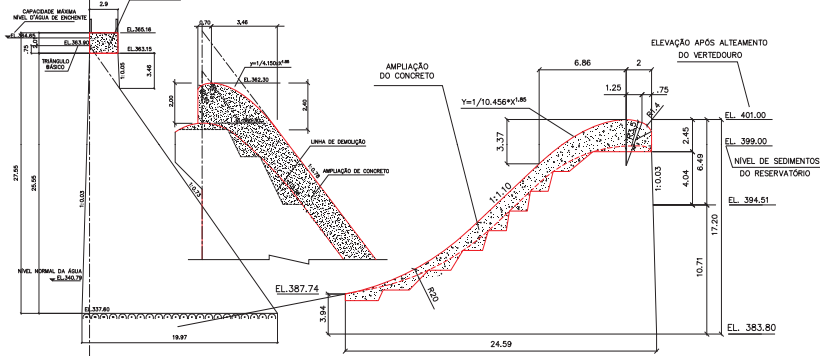

Oeste Dam

Sul Dam

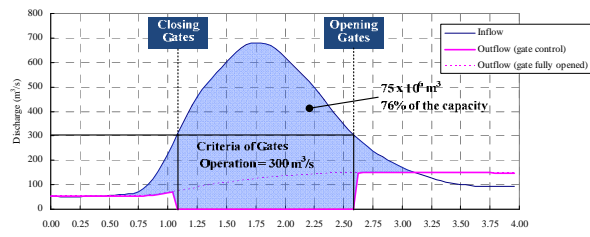

Method of Flood Control at Oeste Dam

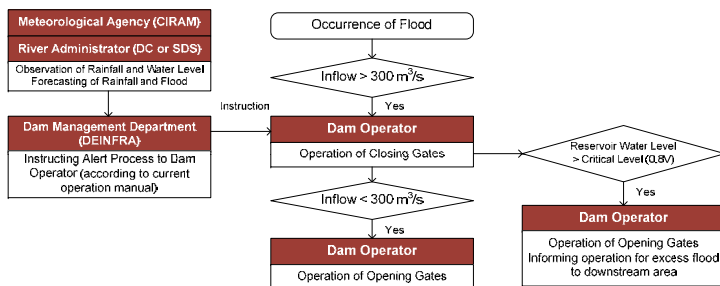

Flowchart of Gates Operation (in case of Oeste Dam)

## Utilization of Existing Hydropower Dams for Flood Control

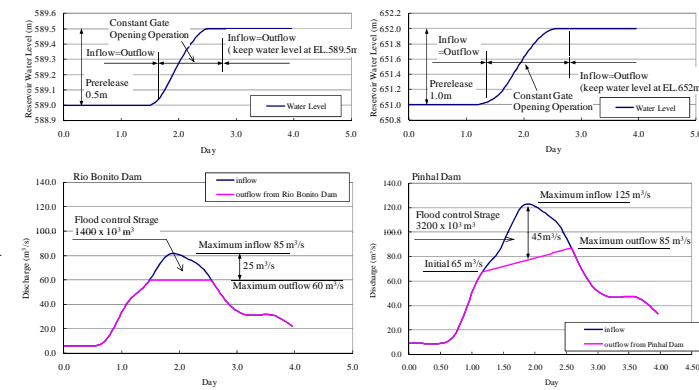
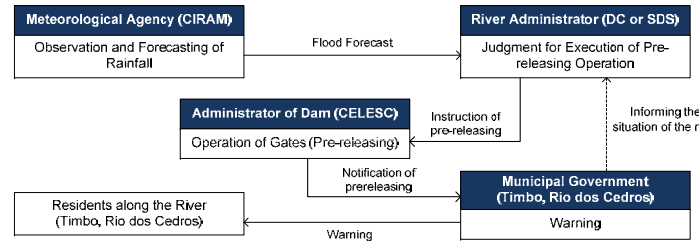

## Installation of Floodgates and Improving Itajai Mirim River

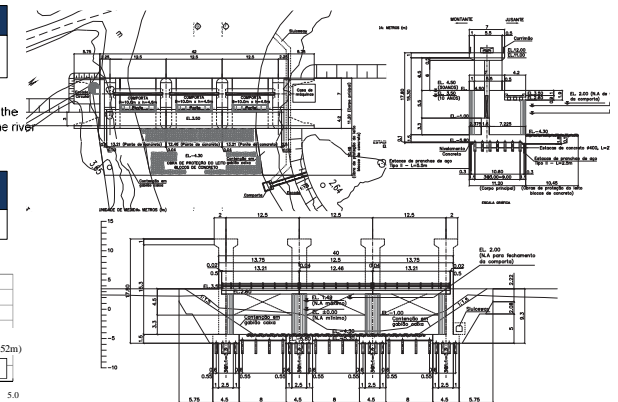

Floodgate at Upstream

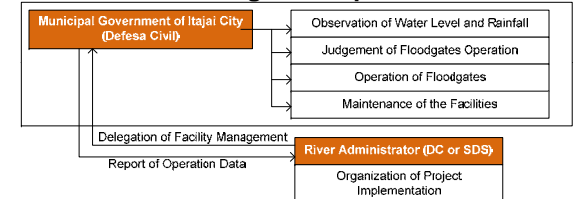

## Water Storage in Paddy Field

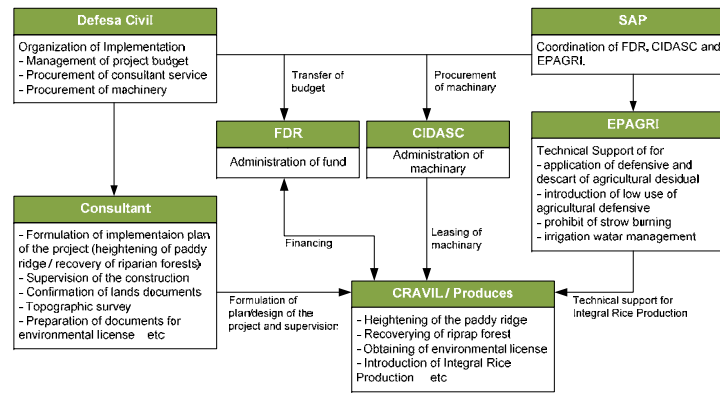

Organization Chart for Water Storage in Paddy Field

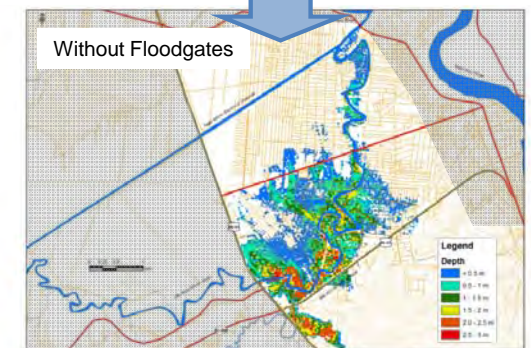
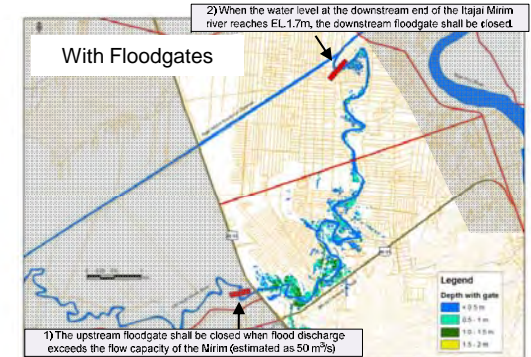



# Feasibility Study of Landslide Management for Itajai River Basin

## Structural Measures

### Selected Priority Sites and Selected Measures

No. of priority order	Site name	Selected countermeasure
1	SC 302 Taio-Passo Manso-5	Horizontal Drainage drilling Gabion retaining wall
2	SC470 Caspar River Bank	Cutting,excavation Embankment Pavement
3	Blumenau –Av Pres Casrelo Branco	Sheet pile Connecting concrete block Geotextile
4	SC418 Blumenau – Pomerode	Closed conduit with open ditch Reinforced earth of polypropylene fiber/cement/sand mixture with vegetation
5	SC474 Blumenau-Massaranduba 2	Reinforced earth of polypropylene fiber/cement/sand mixture with vegetation
6	Gaspar - Luiz Alves, Caspar 9	Reinforced earth of polypropylene fiber/cement/sand mixture with vegetation Horizontal Drainage drilling Gabion retaining wall
7	Gaspar - Luiz Alves, Luiz Alves 6	Reinforced earth of polypropylene fiber/cement/sand mixture with vegetation
8	SC470 Caspar Bypass	Reinforced earth of polypropylene fiber/cement/sand mixture with vegetation
9	SC477 Benedito Novo - Dutor Pedrinho 1	Light weight embankment by EPS(Expanded polystyrene) Pavement
10	SC418 Pomerode - Jaraguá do Sul 1	Gabion retaining wall Embankment Pavement
11	Gaspar - Luiz Alves, Luiz Alves 4	Reinforced earth of polypropylene fiber/cement/sand mixture with vegetation
12	SC474 Blumenau-Massaranduba 1	Reinforced earth of polypropylene fiber/cement/sand mixture with vegetation
13	SC 302 Taio-Passo Manso 4	Reinforced earth of polypropylene fiber/cement/sand mixture with vegetation

## Setting of High Safety Level for the Priority 13 Sites to Avoid Human Loss

The safety target of the structural measures for the 13 priority sites (potential annual loss is more than R\$500 thousands) is to ensure full functionality of the infrastructure against heavy rainfall of 60 years return period.

The 13 priority sites are road slopes of relatively high traffic volume and possibility of high spread failure which directly attack road users. Therefore target safety level shall be high to avoid human loss.

## Adaptation of Economically Advantageous Countermeasures

*-Reinforced earth of polypropylene (PP) fiber/cement/sand mixture with vegetation For erosible red-yellow soils*



*-Lightweight embankment by EPS for deep slide surface landslide*

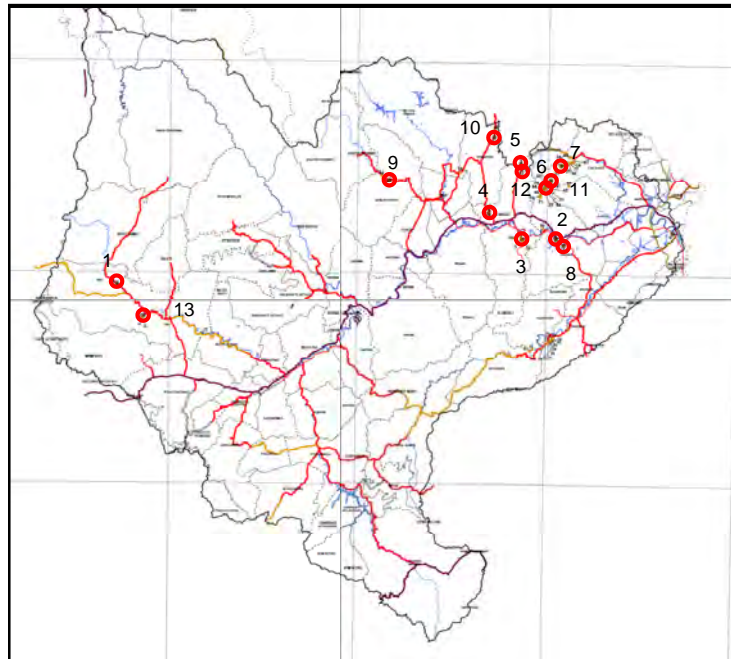
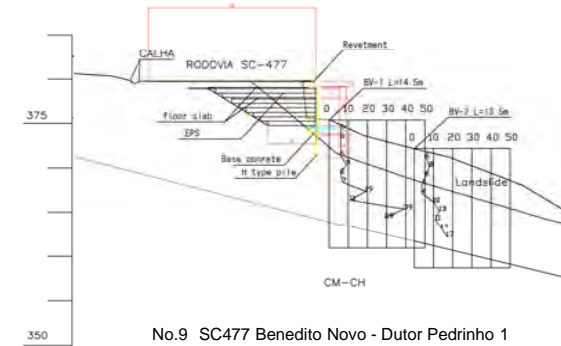

Location Map of Priority Sites for Structural Measures



Example: Soil Splaying with PP fiber/cement/sand mixture under construction



Example: Lightweight embankment by EPS for mountainous road in Japan



Example: 2 years after construction in Japan



Example: 2 years after construction in Japan

## Non-structural measures:

### Early Warning System for Landslide

No.	Measures	Unit and Quantities
1	Pluviometer 53 sites, Modem, Antenna, Computers	1 Unit
2	Radio Base and VHF Data Repeater	1 Unit
3	The Early Warning System Development for Communication, Repository, and Calculation of the Data	1 Unit



PREPARATORY SURVEY  
FOR  
THE PROJECT ON DISASTER PREVENTION  
AND  
MITIGATION MEASURES FOR THE ITAJAI RIVER BASIN

**FINAL REPORT**  
**VOLUME I : EXECUTIVE SUMMARY**

**Table of Contents**

	<u>Page</u>
<b>Part I : Master Plan Study</b>	
1. Introduction .....	1
1.1 Background of the Preparatory Study .....	1
1.2 Objective of the Preparatory Survey .....	1
1.3 Schedule of the Preparatory Survey .....	1
1.4 Executing Agency of the Preparatory Survey .....	2
2. Present Conditions of the Survey Area.....	2
2.1 State Government Institutions .....	2
2.2 Socioeconomic Conditions.....	2
2.3 Topography and Geology .....	3
2.4 Meteorology and Hydrology .....	3
2.5 Land Use .....	3
2.6 Itajaí River Basin Committee .....	4
3. Characteristic of Floods and Probable Flood Discharges of the Itajai River .....	4
3.1 Characteristics of River Channel.....	4
3.2 Existing River Facilities .....	5
3.3 Characteristics of Flood Inundation in the Itajaí River .....	6
3.4 The 2008 Flood .....	7
3.5 Probable Flood Discharge of the Itajai River .....	9
3.6 Evaluation of Flow Capacity .....	9
4. Current Status and Challenge of Existing Flood Forecasting Warning System (FFWS) Activities .....	12
4.1 Current Status of Existing FFWS Activities.....	12
4.2 Issues on Existing Flood Forecasting and Warning Activities .....	13
5. Basic Strategy for Formulation of Flood Mitigation Master Plan.....	14
5.1 Needs for Flood Mitigation of Each City .....	14
5.2 Basic Principles for Planning .....	16
5.3 Basic Strategy for Formulation of Master Plan .....	16
5.4 Basic Strategy for Strengthening of Existing FFWS.....	18
6. Basic Strategy for Formulation of Landslide Management Master Plan .....	18
6.1 Actual State of Landslide Disasters and Restoration Works .....	18
6.2 Evaluation of Landslide Risk and Risk Mapping.....	19

6.3	Needs of Landslide Disaster Mitigation.....	19
6.4	Basic Principles for Landslide Mitigation Measures .....	20
6.5	Basic Strategy for Formulating Mater Pan of Landslide Disaster Mitigation.....	20
7.	Environmental and Social Consideration and Strategic Environmental Assessment (SEA) .....	21
7.1	Strategic Environment Assessment .....	21
7.2	Law of Conservation Units (SNUC Law).....	21
8.	Formulation of the Master Plan on Flood Management.....	21
8.1	Flood Safety Level .....	21
8.2	Selection of Cities for Flood Protection.....	21
8.3	Selection of Flood Control Alternatives.....	22
8.4	Flood Mitigation Master Plan by Safety Level .....	24
8.5	Strengthening Plan of Existing FFWS .....	26
9.	Formulation of Master Plan for Landslide Management .....	27
9.1	Contents of Master Plan .....	27
9.2	Nonstructural Measures (Early Warning System for Landslide and Flash Flood) .....	27
9.3	Structural Measures for Landslide .....	28
9.4	Mitigation Measures for Sediment Yield .....	29
9.5	Mitigation of Flash Flood.....	29
9.6	Capacity Building for Structural Measures and Support for Private Independent Efforts .....	29
10.	Initial Environmental Examination (IEE) .....	30
11.	Total Project Cost, Economic Evaluation and Implementation Plan.....	30
12.	Recommendation for the Master Plan .....	32
12.1	Recommendations on the Master Plan for Flood Mitigation .....	32
12.2	Recommendations on Master Plan for Sediment Disaster Mitigation .....	34
<b>Part II : Feasibility Study</b>		
13.	Selection of Priority Projects for Feasibility Study.....	36
13.1	Selection of Priority Projects.....	36
14.	Feasibility Study on Water Storage in Paddy Fields .....	37
14.1	General Policy of Plan.....	37
14.2	Organization of Project Implementation .....	37
15.	Feasibility Study on Heightening of the Existing Flood Control Dams and Modification of Dam Operation.....	38
15.1	Field Investigations .....	38
15.2	Feasibility Design for Civil Structures.....	40
15.3	Field Investigation on Existing Conduit Gates.....	40
15.4	Modification of the Operation.....	40
15.5	Increasing of Discharge Capacity in Sul and Oeste Dams .....	41
16.	Feasibility Study on Modification of Operation of Existing Hydropower Dams .....	41

16.1	Background of Modification .....	41
16.2	Study on Pre-releasing .....	41
16.3	Recommendation of Organization for Operation .....	42
17.	Feasibility Study on Floodgates in the Itajai Mirim River .....	43
17.1	Topographical Characteristics of Itajai Mirim River.....	43
17.2	Function, Operation and Effectiveness of Floodgates.....	43
17.3	Feasibility Design of Floodgates.....	46
18.	Feasibility Study on Strengthening of Existing FFWS .....	47
18.1	Strengthening of the Existing Hydrological and Meteorological Observation System.....	47
18.2	Verification of the Existing Flood Forecasting Method .....	47
18.3	Proposed Organization for the Strengthening of Existing FFWS .....	49
19.	Feasibility Study on Structural Measures for Landslides .....	50
19.1	Basic Policy.....	50
19.2	Landslide Type and Selection of Type of Structural Measures .....	51
20.	Feasibility Study on Early Warning System for Landslide and Flash Flood.....	52
20.1	Method of Rainfall Monitoring, Data Communication, and Repository .....	52
20.2	Criteria of Rainfall Index for Attention/Alarm.....	52
20.3	Management of Information, Calculation of Rainfall Index, Issuance/Announcement of Attention/Alarm .....	52
20.4	Evacuation Order and Disaster Education.....	52
20.5	Road Traffic Regulation for Risk Avoidance .....	53
21.	Environmental and Social Consideration .....	53
21.1	Review of Initial Environment Examination (IEE) in the Master Plan Study .....	53
21.2	Mitigation Measures for Environmental and Social Impacts .....	53



## Table

	<u>Page</u>
Table 1	Present Land Use within the Itajai River Basin in 2000 ..... 3
Table 2	Return Period of Major Floods ..... 6
Table 3	Damages due to Flood and Sediment Related Disasters in November 2008 ..... 7
Table 4	Expenditure for Emergency Works by the State Government ..... 8
Table 5	Expenditure for Restoration Works by the State Government ..... 8
Table 6	Flow Capacity and Considerations (Itajaí River)..... 10
Table 7	Flow Capacity and Considerations (Itajaí Mirim River and Main Tributaries) ..... 11
Table 8	Warning Standards based on River Water Level ..... 13
Table 9	Situation of the Existing 14 Gauging Stations of FURB/CEOPS ..... 13
Table 10	Flooding Characteristics and Issues of Each City along the Itajai River ..... 14
Table 11	Inventory Item of Landslide Risk Site ..... 19
Table 12	Flood Mitigation Plans by Safety Level..... 24
Table 13	Components of Flood Mitigation Plans by Safety Level ..... 24
Table 14	Proposed New Gauging Stations for Flood Forecasting Warning System ..... 26
Table 15	Contents of Master Plan to Mitigate Landslide, Sediment Yield, and Flash Flood ..... 27
Table 16	Necessary Techniques and Plans to Mitigate Disasters such as Landslide/Flash Flood and Sediment Yield..... 30
Table 17	Cost of Master Plan ..... 30
Table 18	Results of the Economic Evaluation ..... 31
Table 19	Required Flood Control Volume to be Created by Pre-releasing at Two Dams ..... 42
Table 20	Estimated Inundation Area Along the Lower Old Mirim..... 44
Table 21	Main Features of Floodgates ..... 46
Table 22	Structural Measures Against Mountainside Collapse..... 51
Table 23	Structural Measures Against Valley Side Collapse ..... 51
Table 24	List of Structural Measures and Result of Stability Analysis..... 52

## Figure

	<u>Page</u>
Figure 1	Overall Work Schedule of the Preparatory Survey ..... 1
Figure 2	Organization Chart of the Government of the State of Santa Catarina ..... 2
Figure 3	Institutions under the National Water Resources Management System..... 4
Figure 4	Location Map of Major Existing Dams ..... 5
Figure 5	Probable Flood Discharges at Base Points ..... 9
Figure 6	Results of Non-uniform Flow Calculation along the Itajaí River ..... 10
Figure 7	Existing Organizations related FFWS Activities ..... 12
Figure 8	Number of Landslides in the State of Santa Catarina and in Itajaí River Basin from 1980 to 2003 ..... 18
Figure 9	Map of Priority Landslide Risk Sites and Example of Priority Landslide Risk Maps..... 20
Figure 10	Flood Control Alternatives Applicable to Itajai River Basin ..... 22
Figure 11	Illustration of the Composite Section in Blumenau City ..... 23
Figure 12	Micro Basin of Water Shortage for Irrigation in the Itajai River Basin ..... 24
Figure 13	Location Map of the Mitigation Plan for 50-year Flood ..... 25
Figure 14	Schematic Diagram for Early Warning System for Landslide and Flash Flood ..... 28
Figure 15	Example of Structural Measures for Landslide..... 29
Figure 16	Implementation Plan of Flood Mitigation Project for 50-year Flood Safety Level..... 31
Figure 17	Implementation Plan of Structural Measures for Landslide Management..... 31
Figure 18	Image of Stage-Wise Implementation of the Flood Mitigation Plan..... 36
Figure 19	Retention Method of Flood Water in Paddy Fields..... 37
Figure 20	Designed Sections of the Oeste Dam ..... 39
Figure 21	Proposed Energy Dissipater at the Oeste Dam..... 39
Figure 22	Comparison of Overflow Depth of Design Discharge on the Spillway of Sul Dam..... 40
Figure 23	Method of Flood Control at the Oeste Dam..... 40
Figure 24	Method of Flood Control at the Sul Dam..... 41
Figure 25	Recommendation of Organization for Dam Operation ..... 43
Figure 26	Location Map of Floodgates in Old Mirim ..... 43
Figure 27	Location of Water Level and Rainfall Gauges Installed by Itajai City ..... 44
Figure 28	Estimated Inundation Area along Old Mirim With and Without Floodgates ..... 45
Figure 29	Recommendation of Organization for Operation..... 46
Figure 30	General Layout Plan of Floodgate ..... 47
Figure 31	Location Map for Proposed Gauging Station and CCTV ..... 48
Figure 32	Proposed Institutional Organization for the FFWS..... 50

<b>Abbreviations</b>	<b>Portuguese</b>	<b>English</b>
ABRH	Associação Brasileira de Recursos Hídricos	Water Resources Brazilian Association
ALESC	Assembléia Legislativa do Estado de Santa Catarina	Legislative Assembly of The State of Santa Catarina
AMAVI	Associação dos Municípios do Alto Vale do Itajaí	Upper Itajaí Valley Municipalities Association
AMFRI	Associação dos Municípios da Região da Foz do Rio Itajaí	Itajaí River Mouth Municipalities Associations
AMMVI	Associação dos Municípios do Médio Vale do Itajaí	Mid-Valley Municipalities Association
ANA	Agência Nacional de Águas	National Water Agency
ANEEL	Agência Nacional de Energia Elétrica	Electric Power National Agency
APA	Área de Proteção Ambiental	Environmental Protection Area
ARCOVALI	Associação de Rádios Comunitárias de Santa Catarina	Communities Radio Association of Santa Catarina
CASAN	Companhia Catarinense de Águas e Saneamento	Water And Sanitation Company of Santa Catarina
CDRURAL	Conselho Estadual de Desenvolvimento Rural	State Council of Rural Development
CDU	Conselho de Desenvolvimento Urbano	Urban Development Council
CEDEC	Conselho Estadual de Defesa Civil	Civil Defense State Council
CELESC	Centrais Elétricas de Santa Catarina S.A.	Electrical Power Station of Santa Catarina
CEMEAR	Centro de Motivação Ecológica e Alternativas Rurais	Centre For Ecological Motivation And Rural Alternatives
CEOPS	Centro de Operações do Sistema de Alerta da Bacia Hidrográfica do Rio Itajaí-Açu	Centre of Warning System operation of The Itajaí-Açu River Basin
CEPED	Centro Universitário de Estudos e Pesquisas sobre Desastres	University Centre of Disasters Studies And Surveys
CERH	Conselho Estadual de Recursos Hídricos	Water Resources State Council
CIDASC	Companhia Integrada de Desenvolvimento Agrícola de Santa Catarina	Integrated Agricultural Development Company of Santa Catarina
CIRAM	Centro de Informações de Recursos Ambientais e de Hidrometeorologia de Santa Catarina	Information Center of Hydrometeorology And Environmental Resources of Santa Catarina
CNRH	Conselho Nacional de Recursos Hídricos	Water Resources National Council
COHAB	Companhia de Habitação	Housing Company
COMDEC	Comissões Municipais de Defesa Civil	Municipal Civil Defense Committees
CONAMA	Conselho Nacional do Meio Ambiente	Environment National Council
CONSEMA	Conselho Estadual do Meio Ambiente	Environmental State Council
COREDEC	Coordenadorias Regionais de Defesa Civil	Civil Defense Regional Coordination
CRAVIL	Cooperativa Regional Agropecuária Vale do Itajaí	Itajaí Valley Regional Agricultural Cooperative
CTTMAR	Centro de Ciências e Tecnológicas da Terra e do Mar	Science And Technology Center of The Earth And Sea
Defesa Civil	Defesa Civil	Civil Defense
DEINFRA	Departamento Estadual de Infraestrutura	State Department of Infrastructure
DEOH	Departamento de Edificações e Obras Hidráulicas de Santa Catarina	Department of Hydraulic Works And Buildings of Santa Catarina
DNAEE	Departamento Nacional de Águas e Energia Elétrica	National Department of Water And Electrical Energy
DNIT	Departamento Nacional de Infraestrutura de transportes	National Department of Transport Infrastructure
EAS	Estudo Ambiental Simplificado	Simplified Environmental Study
EIA	Estudo de Impacto Ambiental	Environmental Impact Study
EPAGRI	Empresa de Pesquisa Agropecuária e Extensão Rural de Santa Catarina	Company of Agricultural Research And Rural Extension of Santa Catarina
FAPESC	Fundo de Apoio à Pesquisa Científica e Tecnológica do Estado de Santa Catarina	Support Fund For Scientific And Technological Research of Santa Catarina State
FATMA	Fundação do Meio Ambiente	Environment Foundation
FECAM	Federação Catarinense de Municípios	Federation of Santa Catarina Municipalities
FUNAI	Fundação Nacional do Índio	Indians National Foundations
FURB	Fundação Universidade Regional de	Blumenau Regional University Foundation



<b>Abbreviations</b>	<b>Portuguese</b>	<b>English</b>
	Blumenau	
GTC	Grupo Técnico-Científico	Scientific Technical Group
IBGE	Instituto Brasileiro de Geografia e Estatística	Brazilian Institute of Geography And Statistics
INEP	Instituto Nacional de Estudos e Pesquisas Educacionais	National Institute of Educational Studies And Surveys
INPE	Instituto Nacional de Pesquisas Espaciais	National Institute For Space Research
JICA	Agência de Cooperação Internacional do Japão	Japan International Cooperation Agency
MMA	Ministério do Meio Ambiente	Environmental Ministry
MPE	Ministério Público Estadual	State Public Ministry
PCHs	Pequenas centrais hidrelétricas	Small Hydroelectrical Stations
PEEA	Política Estadual de Educação Ambiental	Environmental Education State Policy
PNMA	Política Nacional de Meio Ambiente	Environment National Policy
PNRH	Política Nacional de Recursos Hídricos	Water Resources National Policy
RAP	Relatório Ambiental Prévio	Preliminary Environmental Report
REABRI	Rede de Educação Ambiental da Bacia do Rio Itajaí	Environmental Education Network of The Itajaí River Basin
RIMA	Relatório de Impacto Ambiental	Environmental Impact Report
SDR	Secretaria de Desenvolvimento Regional	Regional Development Secretary
SDS	Secretaria de Estado do Desenvolvimento Econômico Sustentável	Secretary of State For Sustainable Economic Development
SDU	Secretaria de Desenvolvimento Urbano	Urban Development Secretary
SEAIN-COFIEX	Secretaria de Assuntos Internacionais/ Comissão de Financiamentos Externos	Seain-Cofiex
SEMASA	Serviço Municipal de Água, Saneamento Básico e Infra-estrutura de Itajaí	Municipal Service of Water, Sanitation And Infrastructure Itajaí
SIEDC	Sistema Estadual de Defesa Civil	Civil Defence State System
SIRHESC	Sistema de Informações de Recursos Hídricos do Estado de Santa Catarina	Information System of Water Resources of The Santa Catarina State
SISNAMA	Sistema Nacional de Meio Ambiente	Environment National System
SMA	Secretaria de Meio Ambiente	Environment Secretary
SPG	Secretaria de Estado do Planejamento	Secretary of State For Planning
STN/MF	Secretaria do Tesouro Nacional/ Ministério da Fazenda	Secretary of The Treasury / Ministry of Finance
UCs	Unidades de Conservação	Conservation Units
UDESC	Universidade do Estado de Santa Catarina	Santa Catarina State University
UFSC	Universidade Federal de Santa Catarina	Federal University of Santa Catarina
UNIFEBE	Centro Universitário de Brusque	University Centre of Brusque
UNIVALI	Universidade do Vale do Itajaí	Itajaí Valley University

## Part I : Master Plan Study

### 1. Introduction

#### 1.1 Background of the Preparatory Study

The Itajaí River basin with a catchment area of 15,221 km<sup>2</sup> is located at the center of the State of Santa Catarina in the southern part of Brazil. Riparian areas along the Itajaí River and its tributaries have been suffering from flood damage due to repeated inundation. After consecutive attacks of extensive flooding in both 1983 and 1984, the following studies were carried out under the technical cooperation between the Governments of the Federative Republic of Brazil and Japan:

- The Itajaí River Basin Flood Control Project (1986–88) (Master Plan Study and Feasibility Study)
- The Lower Itajaí River Basin Flood Control Project (1988–90) (Feasibility Study)

The Government of the State of Santa Catarina requested for a Japanese official development assistance (ODA) loan for the implementation of the Itajaí River Flood Control Project. However, the loan agreement (L/A) was not concluded due to the lack of guarantee of the Government of the Federative Republic of Brazil.

Catastrophic and heavy rainfall hit the State of Santa Catarina from November to December in 2008, resulting in serious impacts due to flood and sediment-related disasters in the Itajaí River basin. The Government of the State of Santa Catarina showed their willingness to implement a disaster prevention project for the Itajaí River basin with technical and financial assistance by the Government of Japan. The execution of the Preparatory Survey for the Project on Disaster Prevention and Mitigation Measures for the Itajaí River Basin was agreed upon between the Governments of the State of Santa Catarina and Japan on November 5, 2009.

#### 1.2 Objectives of the Preparatory Survey

The objectives of the preparatory survey are the following:

- i) Formulate a master plan for flood and sediment-related disaster prevention and mitigation measures for the Itajaí River basin, and
- ii) Conduct a feasibility study of selected priority project(s) in the master plan with future provision of Japanese ODA loan.

#### 1.3 Schedule of the Preparatory Survey

The preparatory survey was carried out in two phases. The overall work schedule is shown in Figure 1 below.

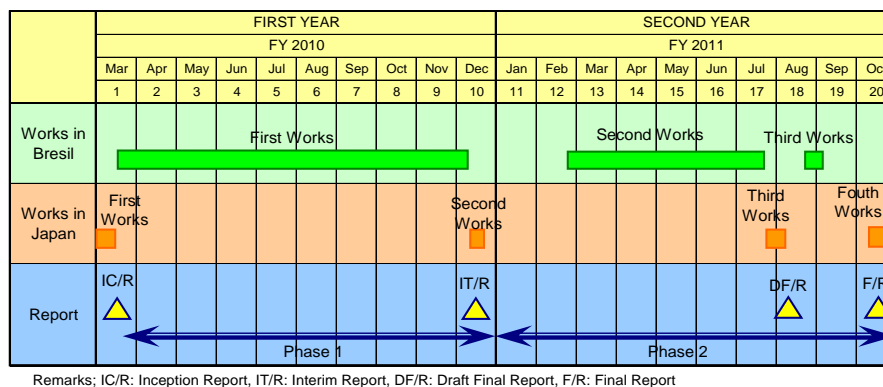

**Figure 1 Overall Work Schedule of the Preparatory Survey**

Phase 1 was carried out from March to December in 2010, and Phase 2 from February to October in 2011. Phase 1 consisted of the basic survey of the preparatory survey area and formulation of a master plan, while Phase 2 was aimed at carrying out a feasibility study of the selected priority projects in the master plan.

### 1.4 Executing Agency of the Preparatory Survey

The executing agency of the preparatory survey is the Fundação de Apoio a Pesquisa Científica e Tecnológica do Estado de Santa Catarina (FAPESC). In order to effectively and smoothly proceed with the Survey, a counterpart meeting that was expected to function as a steering committee was established on May 19, 2010. FAPESC selected members of the counterpart meeting mainly from the member organizations of GTC. In view of various organizations to be involved in this survey, three chief counterpart personnel were appointed from SDS, Defesa Civil and DEINFRA. In January 2011, a new administration system was launched under the new Governor of the State of Santa Catarina. Along this line, the Defesa Civil was promoted to an independent secretary of the state government. In this regard, the executing agency of the preparatory survey was changed from FAPESC to the State Secretary of Defesa Civil. However, FAPESC participates in the planning process of the feasibility study.

## 2. Present Conditions of the Survey Area

### 2.1 State Government Institutions

Figure 2 shows the organizational structure of the Government of the State of Santa Catarina as of December 2010. The administrative organization is composed of 21 departments, 36 regional development offices and 29 affiliated entities.

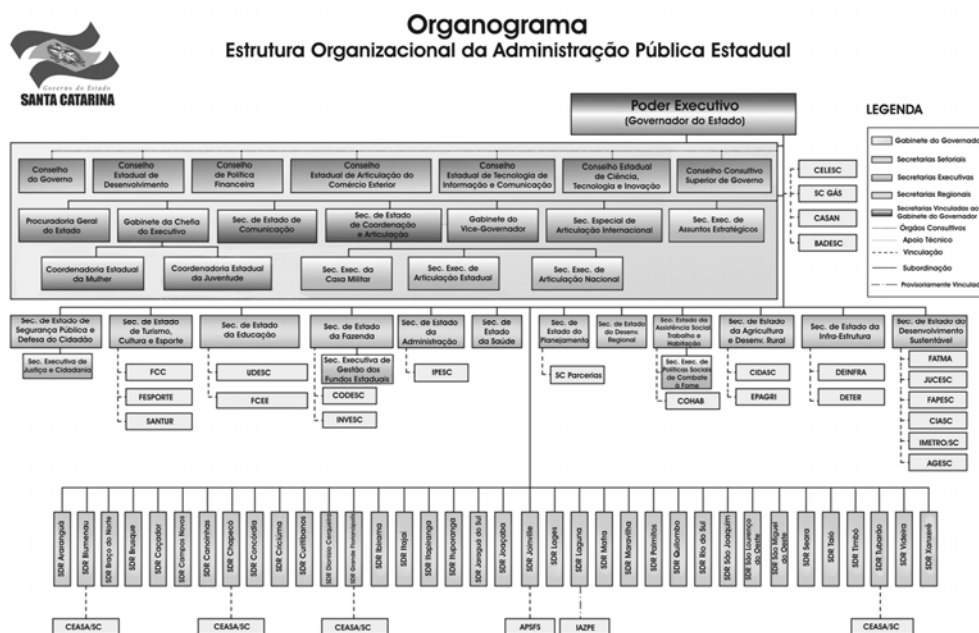

Source: Government of Santa Catarina State

Figure 2 Organizational Chart of the Government of the State of Santa Catarina

### 2.2 Socioeconomic Conditions

The total population of the Itajaí River basin in 2009 was recorded at 1.23 million, which is about 20% of the total population of the State of Santa Catarina. The average annual population growth in the period of 1970–2009 was 2.0%, as shown in Table X below. The cities of Itajaí, Blumenau, and Brusque show higher population growth. On the other hand, population growth



in the upper Itajaí River basin shows stagnation or a decreasing trend, indicating significant migration towards middle-class cities. The services sector prevails in terms of gross regional domestic product (GRDP) in the Itajaí River basin, which accounts for around 50.2% of the GRDP. In Itajaí City, the port services sector carries out the most important economic activities. The industrial sector has been the major engine of economic growth in the regions of Brusque, Timbó, Blumenau and Ibirama. The services sector has been recently growing at an average growth rate of over 20% in all regions.

### 2.3 Topography and Geology

The Itajaí River basin is surrounded by mountains with elevations varying from 200 to 1,750 m, except on the Atlantic Ocean side. For the entire Itajaí River basin, approximately 11% of its area has an altitude that range below 100 m, predominantly 53% range from 500 to 1000 m, and less than 1% range above 1000 m. The geology of Itajaí River basin has a base from the Archean to Proterozoic eons, which compose the stable continent of South America, and above it, there are sedimentary rocks from the Paleozoic and Mesozoic eras. and the upper layer consists of basaltic rocks run off from the Mesozoic era. Except for the alluvial portion that stretches out on to the lowlands of the Atlantic Coast and of the riverbanks, the geology is generally old in the northeast region and young in the southwest region. In the upstream areas of the basin, there are rocks from the Paleozoic to Mesozoic eras. In the middle and lower portions, there are sedimentary rocks from the Paleozoic era, and metamorphic rocks from the Archean to Proterozoic eons.

### 2.4 Meteorology and Hydrology

The average annual basin mean rainfall in the period of 1950–2008 was 1,560 mm. The maximum annual rainfall was 2,632 mm in 1983, and the minimum is 2,632 mm in 1983. However, in 2008, when the most serious flood disaster in recent times occurred, the annual basin mean rainfall was 1,899 mm. This is due to the concentration of rainfalls at the lower part of Itajaí River basin from Indaial City during the said flood in 2008. The monthly rainfall is relatively low from April to August, gradually increasing from September onwards, and then occurs at the highest during January and February. However, historical records show that large-scale floods occurred in July 1983 and August 1984, even during a period of relatively low rainfall. The annual mean discharges in 1980–2004 are 40 m<sup>3</sup>/s at the Ituporanga station, 131 m<sup>3</sup>/s at the Rio do Sul station, and 269 m<sup>3</sup>/s at the Indaial station. The annual mean discharge at the Blumenau station is 340 m<sup>3</sup>/s. Although the wet and dry seasons are not clearly divided, the monthly mean discharges from September to February are generally higher than the annual mean discharge.

### 2.5 Land Use

The forest area accounts for 64.6% of the whole basin, followed by agricultural land use of crops and pastures with 36.7%. Table 1 presents the current land use in flood vulnerable areas along the Itajaí River. Major urban areas in the basin are located in flood vulnerable areas. In this regard, most of the basin population lives in these flood prone areas.

**Table 1 Present Land Use within the Itajaí River Basin in 2000**

Land Use Category	Area (km <sup>2</sup> )	Ratio (%)
Crops/pastures	4,591.69	36.7
Forests	9,644.44	64.6
Rice paddies	241.22	1.6
Urban region	367.13	2.5
Water bodies	88.75	0.6
<b>Total</b>	<b>14,933.23</b>	<b>100.0</b>

Source: JICA Survey Team (based on IBGE data)

## 2.6 Itajaí River Basin Committee

The federal government stipulated the National Water Resources Policy and the National Water Resources Management System in Law No. 9433 on January 8, 1997. This law stipulates that water resources management shall be executed independently for each river basin by establishing management standards with provision of legal norms, and shall be decentralized with the establishment of an agency of participatory approach. With regards to the policy on water, regulations are established by the water resources councils. At the federal level, the National Agency of Waters (ANA) is the executing agency for the National Water Resources Policy. At the state level, water agencies are established in each basin and execute the water resources policy. Figure 3 shows the composition of the National Water Resources Management System under the law.

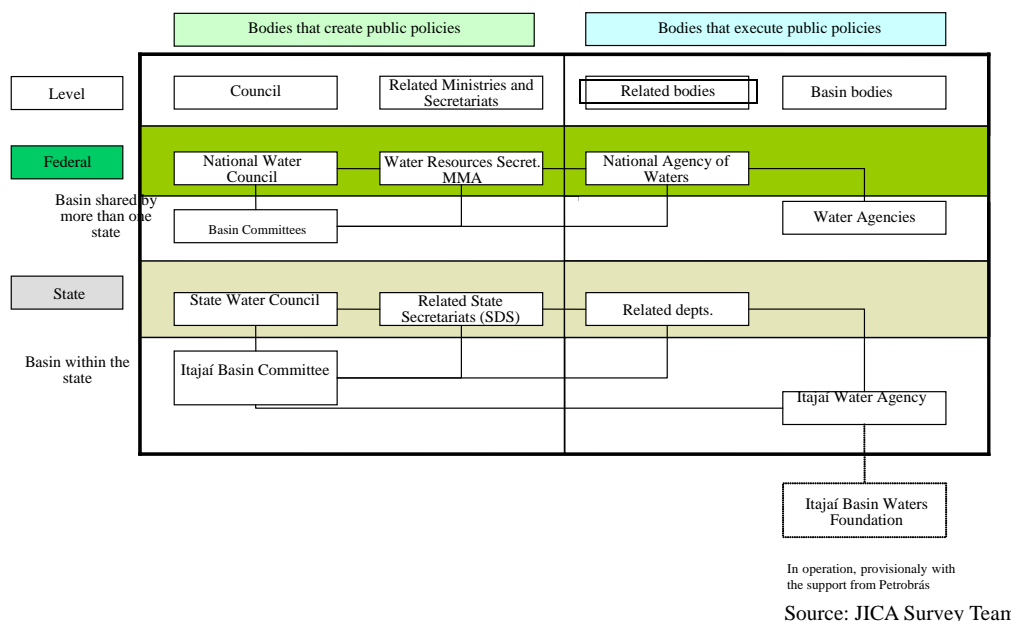

**Figure 3 Institutions under the National Water Resources Management System**

The Itajaí River Basin Committee is an institution established by State Decree 2109/97. It is composed of 50 organizations, of which 20 are water users, 20 are community representations and 10 are representatives of public institutions.

## 3. Characteristic of Floods and Probable Flood Discharges of the Itajaí River

### 3.1 Characteristics of River Channel

The Itajaí River is characterized by very gentle channel slopes of 1/15,000 to 1/20,000 over low-lying flat areas at the lower reaches until Blumenau City. As a result, inundation during large floods can be extensive. In particular, the riverbed elevation in Blumenau City is lower than the mean sea level. At the middle reaches from Blumenau City to Lontras City (near the upstream location of 170 km from the river mouth), it becomes very steep with gradients between 1/100 and 1/1,500, and gentle again at over 1/3,000 at the upper reaches between the cities of Lontras and Rio do Sul.

The river width varies from 200 to 300 m at the lower reaches, from 150 to 200 m near Blumenau City, and between 100 and 150 m at Rio do Sul City, being increasingly narrower at its upstream reaches. The Itajaí River is nearly a natural river without significant dykes due to river improvement works, having only partial works such as the concrete walls at the Itajaí Port and several shortcut channels in the Itajaí Mirim River.

### 3.2 Existing River Facilities

The most typical flood control facilities are three dams constructed at the tributaries, namely, the Oeste, Sul, and Norte dams. Since these dams are exclusive for the purpose of flood control, reservoirs always remain empty for retaining floodwater. The total drainage area of the three dams is 4,633 km<sup>2</sup>, which is equivalent to 31% of the total drainage area of the Itajaí River main stream. The Rio Bonito and Pinhal Dams are exclusive for hydropower generation, and are owned by Celesc. These two dams are located at the Cedros River, which is a tributary of the Benedito River. These dams are equipped with only power generation facilities and spillways because they are utilized only for energy generation, without flood control function. Figure 4 shows the location map of these dams.

Besides these dams, there are limited facilities such as revetment of concrete blocks at the water-colliding portion on the right bank of the Itajaí River in Blumenau City, and small-scale revetment works by means of simple gabions and ripraps. No flood control works have been implemented so far by means of diking and widening of the river channel to increase flow capacity.

In the Itajaí Mirim River, a straight shortcut channel was constructed to flush floods more rapidly near Itajaí City. However, it might be said that the shortcut channel could not solve flooding issues as expressed through some opinions that this shortcut channel has caused an increase of flood discharge at the downstream reaches of Itajaí City.

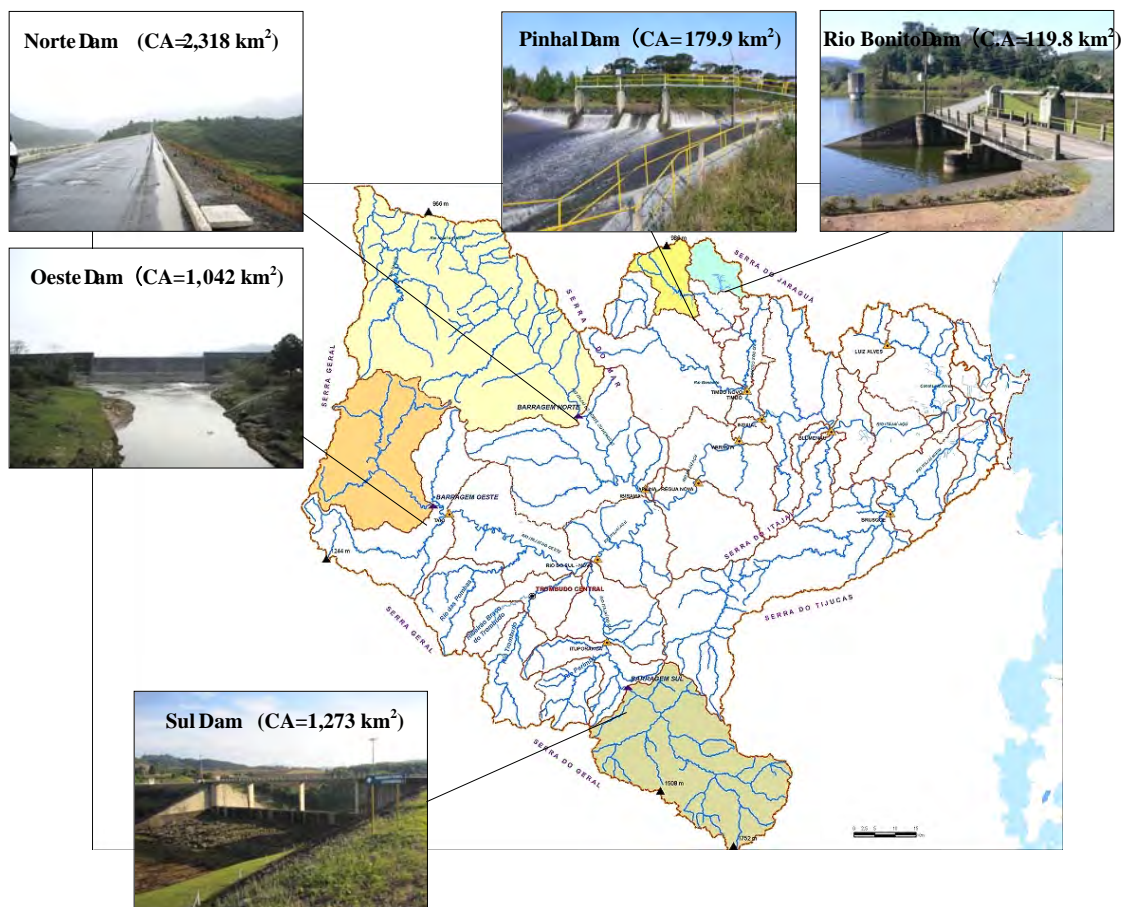

Source: JICA Survey Team

Figure 4 Location Map of Major Existing Dams

### 3.3 Characteristics of Flood Inundation in the Itajaí River

Considering the frequency and scale of flood damage by municipality, the basic needs for flood mitigation measures by municipality are the following:

- i) In recent years, the floods that caused relatively significant damage are the July 1983, August 1984, May 1992, October 2001 and November 2008 floods.
- ii) The most serious flood damage occurred in Blumenau City, followed by Itajaí, Gaspar and Rio do Sul Cities. These four cities are highly prioritized to implement mitigation measures because they have a great number of inhabitants and industries.
- iii) Besides the four cities mentioned above, Timbó and Taió Cities are also considered to implement mitigation measures because of the occurrence of flood inundation. In this regard, it is necessary to clarify the interferences to Timbó City due to the operation of hydropower dams (Rio Bonito and Pinhal Dams) upstream of the Cedros River, and to Taió City due to the operation of Oeste Dam.
- iv) Although Navegantes and Ilhota Cities relatively suffer from flood, the level of safety due to flooding would increase as a result of the provision of flood control measures to priority cities such as Itajaí, Blumenau and Gaspar.
- v) On the other hand, in Brusque and Ituporanga Cities, no serious flood damage has occurred in recent years, although these cities were expected to be affected by larger floods with a recurrence interval of more than 50 years such as the 1984, 1984 and 2008 floods (see Table 3.3.3). Accordingly, these cities might be of low priority with regards to flood control measures due to the relatively high flow capacity of the current river channel as compared to that in the priority cities.
- vi) Flow capacity of the Itajaí River is relatively high in the stretch between Blumenau City and the confluence to the Itajaí do Norte River (see details of flow capacity in Section 3.6). The cities located along this river stretch, such as Indaial City, are of low priority with regards to flood control measures because the damages caused by flood inundation are minimal.

The magnitudes of the major floods were evaluated in terms of the probability of occurrence of flood events, which is called the return period, as shown in Table 2. The floods that occurred in 1983 and 1984, which caused serious damages over the basin, were evaluated to have a return period of 76 and 66 years, respectively. These are then followed by the 1992 flood with a return period of 33 years. The magnitude of the 2008 flood was evaluated as only a 5-year flood, because of locally concentrated rainfall distribution over the downstream basin.

**Table 2 Return Period of Major Floods**

Date Occurred	Four-day Rainfall (Average of the whole basin)	Return Period (Years)	Situation of Damage
31.10.1961	139 mm	6	—
26.09.1963	149 mm	8	—
25.08.1972	166 mm	13	—
19.12.1980	147 mm	7	—
06.07.1983	223 mm	76	Large-scale damage from Itajaí to Blumenau Cities. Large-scale damage from Lontras to Rio do Sul Cities. Medium-scale damage to Timbó, Taió, Rio do Oeste and Ituporanga Cities.
05.08.1984	218 mm	66	Large-scale damage to Itajaí, Gaspar and Blumenau Cities. Large-scale damage to Brusque City. Medium-scale damage to Taió and Ituporanga Cities.
28.05.1992	196 mm	33	Large-scale damage from Itajaí to Blumenau Cities.

Date Occurred	Four-day Rainfall (Average of the whole basin)	Return Period (Years)	Situation of Damage
			Relatively small-scale damage to Rio do Sul City. Medium-scale damage to Timbó City.
31.01.1997	134 mm	5	Relatively large-scale damage to Gaspar City. Small-scale damage to Blumenau City.
02.07.1999	150 mm	8	Small-scale damage to Rio do Sul City.
29.09.2001	147 m	7	Small-scale damage to Itajaí, Gaspar, Blumenau, Indaial, and Lontras Cities. Medium-scale damage to Rio do Sul City. Small-scale damage to Timbó and Taió Cities.
18.05.2005	144 mm	7	No significant damage.
21.11.2008	135 mm	5	Large-scale damage to cities at downstream. However, due to localized torrential rainfall, the calculated basin mean rainfall shows a smaller return period.
23.04.2010	130 mm	4	No official information is available. In the field survey, there was small-scale damage to Rio do Sul, Timbó and Taió Cities.

Source: JICA Survey Team

### 3.4 The 2008 Flood

The 2008 flood occurred from November 18 to 27, 2008. The biggest rainfalls occurred during the four days from 21 to 24, and the basin mean rainfall for that four-day period was 121 mm. The 2008 flood was characterized as a localized concentration of heavy rainfalls at the downstream subbasins, reaching 236 mm in the Itajaí Açu subbasin, 214 mm in the Benedito subbasin, and 160 mm in the Itajaí Mirim subbasin.

The maximum river water level was recorded at 11.5 m at the Blumenau station on midnight of November 24, 2008 (this data might be the reading of the water level gauge). The discharge peaks were estimated by using the H-Q curve that was prepared by the Survey Team. The results are as follows:

Blumenau station:	H = 11.5m	Q = 4,200 m <sup>3</sup> /s
Timbó station:	H = 8.0 m	Q = 710 m <sup>3</sup> /s
Indaial station:	H = 6.0 m	Q = 3,100 m <sup>3</sup> /s

Table 3 shows the damages to each city due to flood and sediment-related disasters. Both Ilhota and Blumenau Cities were heavily damaged. Almost the total populations of Blumenau, Brusque, Gaspar, Ilhota, Itajaí and Luis Alves Cities were affected.

**Table 3 Damages due to Flood and Sediment-related Disasters in November 2008**

City	Population	Ratio of affected people	People evacuated	Affected people	Victims house collapse	Injured	Dead	Damaged houses	Damaged roads (km)
Benedito Novo	9,841	31 %	102	712	210		2	191	576
Blumenau	292,972	35 %		25,000	5,209	2,383	24	18,000	
Brusque	94,962	100 %		8,000	1,200	66	1	1,220	120
Gaspar	52,428	100 %		7,100	4,300	280	16	8,700	600
Ilhota	11,552	100 %	3,500	3,500	1,300	67	26	406	
Itajaí	163,218	100 %	100,000	18,208	1,929	1,800	5	28,400	
Luis Alves	8,986	100 %		3,232	239	41	10	220	40
Pomerode	25,261	1 %		182	48		1	50	100
Rio dos Cedros	9,685	88 %		595	96			283	300
Rodeios	10,773	5 %		27	42		4	35	144
Timbo	33,326	2 %						264	
<b>Total</b>	<b>713,004</b>		<b>103,602</b>	<b>66,556</b>	<b>14,573</b>	<b>4,637</b>	<b>89</b>	<b>57,769</b>	<b>1,880</b>

Source: AVADANs sent by the municipalities to the Civil Defense of Santa Catarina on November 24 and 25, 2008.

The expenditure for emergency activities was estimated by dividing the expenditures for emergency works and restoration works conducted by the state government, as shown in Table 4.

**Table 4 Expenditure for Emergency Works by the State Government**

Institution	Budget (R\$ million)	Contents
DEINFRA	254.8	Restoration of roads
Municipal Governments	25.8	Restoration of municipal roads
	19.0	Removal of debris from rivers
	29.0	Restoration of bridges
	64.0	Restoration of public facilities
COHAB/SC	8.6	Construction of houses for victims of house collapse
SST	6.5	Relief works
State Secretariat of Health	70.0	Measures for sanitary and epidemics
Civil Defense	34.8	Measures for emergency evacuation
Regional Development Department (SDR)	48.2	Disaster prevention works
Civil Defense Fund	1.5	Emergency works
State Secretariat of Public Security and Safety (SSP)	3.0	Emergency works
State Secretariat of Administration (SEA)	11.3	Restoration of schools
Water and Sanitation Company (CASAN)	2.0	Restoration for water and sewerage systems
Celesc	29.0	Restoration of electric supply system
State budget	49.0	Expenditure for emergency measures for victims
<b>Total</b>	<b>656.5</b>	

Source: Reconstruction of Areas affected by the November 2008 Catastrophe, State of Santa Catarina

**Table 5 Expenditure for Restoration Works by the State Government**

Institution	Budget (R\$ million)	Contents
Itajaí Port	350.0	Restoration of Itajaí Port
DEINFRA	1.0	Establishment of information monitoring system for the areas downstream and upstream of dam
EPAGRI/CIRAM	10.0	Preparation of land use maps and of risk maps, meteorological analysis, flood risk zones, improvement of meteorological alert system, GIS improvement, etc.
Civil Defense	1.0	Training
GTC	10.0	Formulation of the disasters risk mitigation plan in the Itajaí River basin
DEINFRA	112.0	Detours
	1.0	Restoration of asphalt roads, restoration of earth roads
Celesc	1.5	Protection works for substations
	3.8	Electric supply system
SDS	20.3	Establishment of map information system, meteorological and hydrologic monitoring system of FURB, and meteorological monitoring system of EPAGRI
SAR	526.0	Postponement of debt repayment, installation of special credit lines, etc.
SEF	1,029.2	Measures of R\$845 million for administrative damages, R\$71.2 million for product losses, and R\$113 million for infrastructure damages - Exemption of ICMS tax (until February 2009) - Postponement of ICMS tax payment - Deduction of ICMS tax regarding loss of goods
<b>Total</b>	<b>2,065.8</b>	

Source: Reconstruction of Areas affected by the November 2008 Catastrophe, State of Santa Catarina



### 3.5 Probable Flood Discharge of the Itajaí River

The probable flood discharges were estimated at the base points by applying the calibrated flood runoff model shown in Figure 5. In this estimation, the releasing gates of the three existing flood control dams are assumed to be fully opened.

The flooding pattern due to large floods in the low-lying area from the federal highway BR 101 to Gaspar or Ilhota Cities is characterized by widespread and prolonged inundation. This is due to the fact that the downstream reaches of the Itajaí River is unprotected by some dikes. Given the conservation of such flood-retarding effect, the probable flood discharges at Itajaí City for flood control planning could be minimized and hence, the construction cost could be reduced. In light of such concerns, the probable flood discharges downstream from Ilhota City were reestimated as provided with such retarding effect to floods.

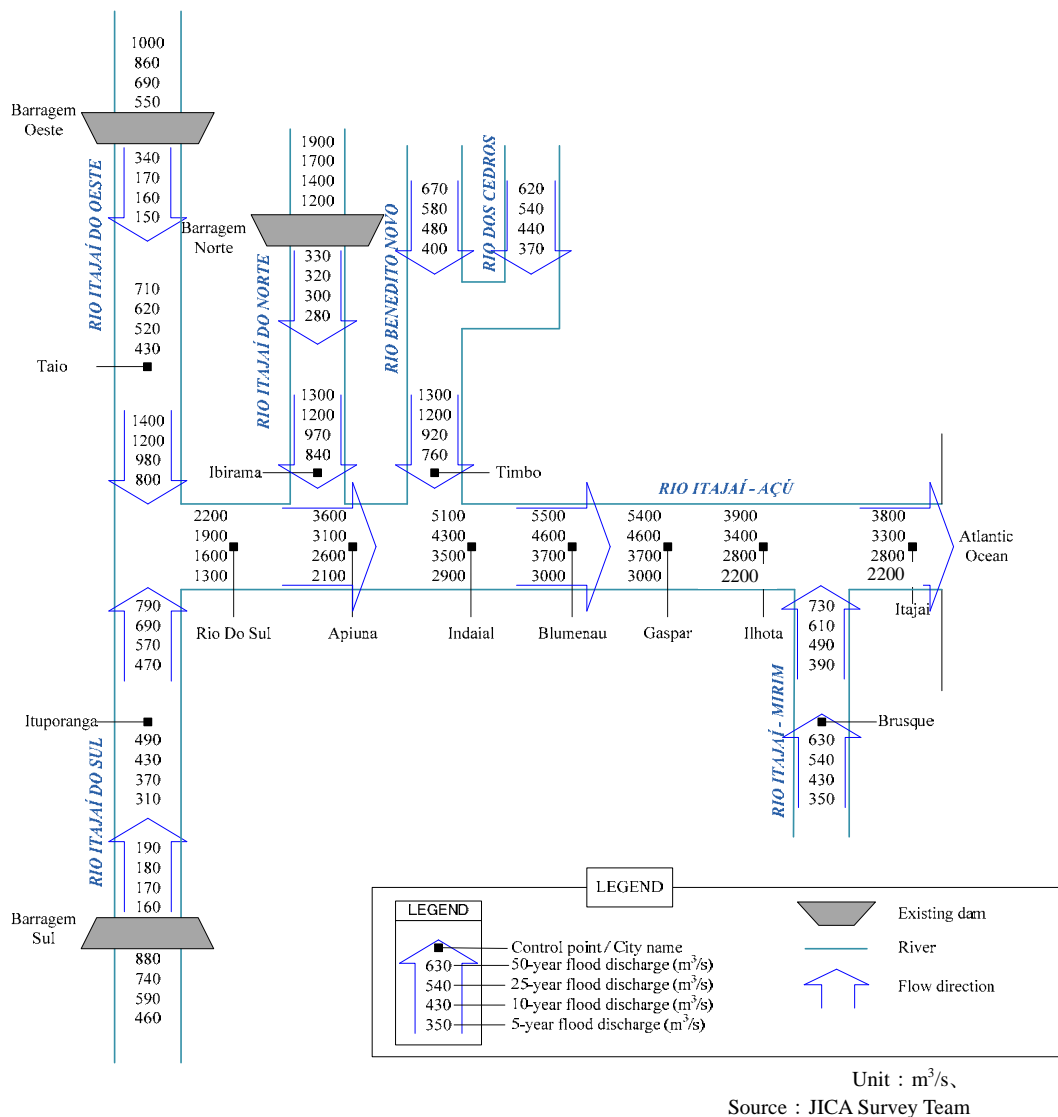
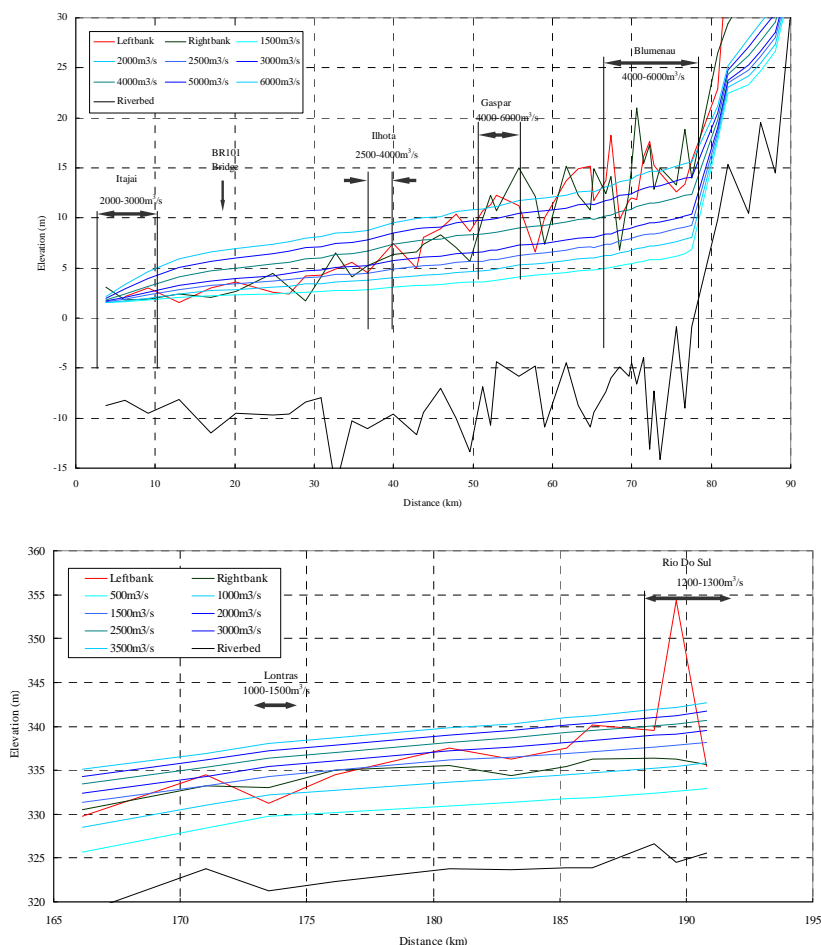

Figure 5 Probable Flood Discharges at Base Points

### 3.6 Evaluation of Flow Capacity

The river cross section survey at the Itajaí River was carried out under the preparatory survey during the period of June–August 2010. Among the 143 total surveyed sections, 79 sections were at the main stream of Itajaí River and 64 sections were at its tributaries. In order to

evaluate the current flow capacity of river channels for the Itajaí River and its main tributaries, non-uniform flow calculation was carried out by use of the river cross section data surveyed. The results of the calculation in the main stream of Itajaí River are shown in Figure 6 below.



Source : JICA Survey Team

**Figure 6 Results of Non-uniform Flow Calculations along the Itajaí River**

Based on the results of the non-uniform flow calculations, the flow capacity at various locations was estimated in terms of the bankfull discharge of river channel. The estimated flow capacity was evaluated compared to the probable flood discharges (see Figure 5) as summarized in Table 6 below.

**Table 6 Flow Capacity and Considerations (Itajaí River)**

River	City	Flow Capacity (m <sup>3</sup> /s)	Necessity of flood mitigation measures
Itajaí	Itajaí, Navegantes	2,000 to 3,000	Flow capacity: around 5-year flood discharge (especially Itajaí city is low) Experiences of flood damages in the past and seriousness: low elevation area of Itajaí city has frequently suffered from inundations, high necessity of flood mitigation. Damage potential by floods: high damage potential due to large population and importance in the economical aspect of the SC State. Necessity of flood mitigation measures: high priority for mitigation measures
	Ilhota	2,500 to 4,000	Flow capacity: around 10 to 25-year flood discharge Experiences of flood damages in the past and seriousness: damages have occurred in case of huge floods. Damage potential by floods: low damage potential due to small population. Necessity of flood mitigation measures: low priority for mitigation measures.

River	City	Flow Capacity (m <sup>3</sup> /s)	Necessity of flood mitigation measures
	Gaspar	5,100 to 6,000	Flow capacity: around 25 to 50-year flood discharge (large capacity at the central of the city) Experiences of flood damages in the past and seriousness: damages have occurred in case of huge floods. Damage potential by floods: high damage potential due to large population. Necessity of flood mitigation measures: mitigation measures are required but medium priority.
	Blumenau	4,200 to 6,000	Flow capacity: around 25 to 50-year flood discharge Experiences of flood damages in the past and seriousness: damages have occurred in case of huge floods. Damage potential by floods: high damage potential due to very large population and importance in the economical and social aspects of the SC State. Necessity of flood mitigation measures: mitigation measures are required but medium priority, but as the flow capacities of small tributaries such as Garcia and Velha Rivers are 5 to 10-year, flood mitigation measures along the tributaries are highly prior.
	Indaial	5,700	Flow capacity: more than 50-year flood discharge Experiences of flood damages in the past and seriousness: there has been few flood damages Damage potential by floods: large population, but hard to suffer from flood. Necessity of flood mitigation measures: no necessity of mitigation measures.
	Lontras	1,000 to 1,500	low capacity: around 5 to 10-year flood discharge Experiences of flood damages in the past and seriousness: there has been few flood damages in the urban area. Damage potential by floods: low damage potential due to small population. Necessity of flood mitigation measures: no necessity of mitigation measures.
	Rio do Sul	1,220	Flow capacity: around 5-year flood discharge Experiences of flood damages in the past and seriousness: low elevation area of Rio do Sul city has frequently suffered from even small flood, high necessity of flood mitigation. Damage potential by floods: high damage potential due to large population and importance as the economical center of upper Itajaí River basin region. Necessity of flood mitigation measures: high priority for mitigation measures.

Source: JICA Study Team

**Table 7 Flow Capacity and Considerations (Itajaí Mirim River and Main Tributaries)**

River	City	Flow Capacity (m <sup>3</sup> /s)	Considerations Compared to Probable Discharge
Itajaí Mirim	Itajaí	300 (downstream reach after the confluence) 500~600 (Canal) 200~300 (Old)	Flow capacity: less than 5-year flood discharge in downstream reach after confluence, around 25 to 50-year in Canal, less than 5-year in Old Mirim. Experiences of flood damages in the past and seriousness: low elevation area of Itajaí city has frequently suffered from inundations, high necessity of flood mitigation. Damage potential by floods: high damage potential due to large population and importance in the economical aspect of the SC State. Necessity of flood mitigation measures: high priority for mitigation measures
	Brusque	550~700	Flow capacity: around 25 to 50-year flood discharge Experiences of flood damages in the past and seriousness: the present roads on the both banks function as a high water channel portion of the likely compound river channel, therefore, the roads have frequently suffered, but urban area has not suffered so frequently. Damage potential by floods: high damage potential due to large population in case of huge floods. Necessity of flood mitigation measures: mitigation measures are required but low priority.
Benedito	Timbó	860	Flow capacity: around 5 to 10-year flood discharge Experiences of flood damages in the past and seriousness: there are informations of frequent inundations. Damage potential by floods: medium damage potential due to medium size of population. Necessity of flood mitigation measures: mitigation measures are required but

River	City	Flow Capacity (m <sup>3</sup> /s)	Considerations Compared to Probable Discharge
			medium priority.
Itajaí do Norte	Ibirama	more than 2,000	Flow capacity: more than 50-year flood discharge Experiences of flood damages in the past and seriousness: there has been few flood damages Damage potential by floods: medium population, but hard to suffer from flood. Necessity of flood mitigation measures: no necessity of mitigation measures.
Itajaí do Oeste	Rio do Sul	760	Flow capacity: less than 5-year flood discharge Experiences of flood damages in the past and seriousness: low elevation area of Rio do Sul city has frequently suffered from even small flood, high necessity of flood mitigation. Damage potential by floods: high damage potential due to large population and importance as the economical center of upper Itajaí River basin region. Necessity of flood mitigation measures: high priority for mitigation measures.
	Taió	440	Flow capacity: around 5 to 10-year flood discharge Experiences of flood damages in the past and seriousness: urban area has suffered from frequent inundations. Damage potential by floods: medium damage potential due to medium size of population. Necessity of flood mitigation measures: mitigation measures are required but medium priority.
Itajaí do Sul	Rio do Sul	300~500	Flow capacity: less than 5-year flood discharge Experiences of flood damages in the past and seriousness: low elevation area of Rio do Sul city has frequently suffered from even small flood, high necessity of flood mitigation. Damage potential by floods: high damage potential due to large population and importance as the economical center of upper Itajaí River basin region. Necessity of flood mitigation measures: high priority for mitigation measures.
	Ituporanga	450	Flow capacity: around 30-40 year flood discharge Experiences of flood damages in the past and seriousness: there are few record of flood damages Damage potential by floods: medium population, urban area extends on the hill, so hard to suffer from flood. Necessity of flood mitigation measures: no necessity of mitigation measures.

Source: JICA Study Team

#### 4. Current Status and Challenge of Existing Flood Forecasting and Warning System (FFWS) Activities

##### 4.1 Current Status of Existing FFWS Activities

The existing FFWS activities have not been systematically planned and conducted throughout the Itajaí River basin due to lack of sufficient communication among related organizations of the state government. Figure 7 shows the existing organizations related to FFWS activities in the state.

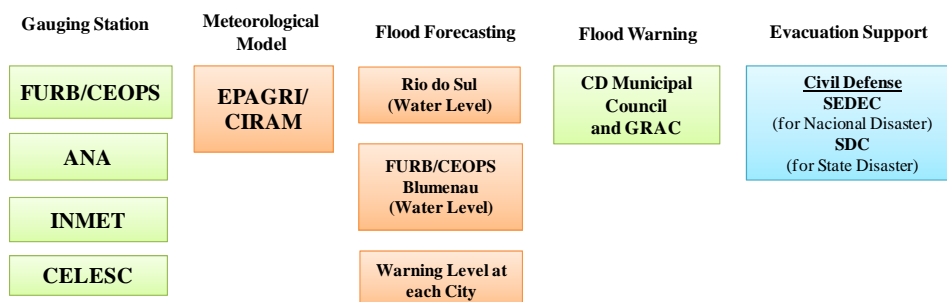

Source: JICA Study Team

Figure 7 Existing Organizations related to FFWS Activities

As shown in Table 8, 16 cities including Itajaí have “warning levels”. Such warning levels are established based on past floodwater levels. The Defesa Civil of each city monitors the rise of river water levels. When it rises, the river water level is immediately reported to the CD Municipal Council.

**Table 8 Warning Standards based on River Water Level**

City	Elevation EL. m	Catchment Area (km <sup>2</sup> )	Normal Level (m)	Standby Level (m)	Warning Level (m)	Emergency Level (m)
Taio	360	1,575	4.0	6.0	6.5	over 7.5
Rio do Oeste	-	-	4.0	6.0	9.0	over 9.0
Trombudo	350	248	3.0	4.0	7.5	over 7.5
Ituporanga	370	1,670	2.0	3.0	4.0	over 4.0
Vidal Ramos	-	-	3.0	4.0	6.0	over 5.0
Rio do Sul	350	5,100	4.0	5.0	6.5	over 6.5
Ibirama	151	3,314	2.0	3.0	4.5	over 4.5
Apiuna	93	9,241	3.0	6.0	8.5	over 8.5
Benedito Novo	90	692	1.5	2.5	3.5	over 3.5
Rio dos Cedros	80	510	1.5	2.5	3.5	over 3.5
Timbo	73	1,342	2.0	4.0	6.0	over 6.0
Indaial	60	11,151	3.0	4.0	5.5	over 5.5
Blumenau	12	11,803	4.0	6.0	8.5	over 8.5
Gaspar	11	12,141	4.0	6.0	8.5	over 8.5
Ilhota	-	12,357	6.0	8.0	10.5	over 10.5
Itajaí	-	15,221				

Source: FURB/CEOPS

#### 4.2 Issues on Existing Flood Forecasting and Warning Activities

FURB/ CEOPS installed 14 hydraulic gauging stations for the FFWS of Itajaí River in 1985 under the commission from SDS. However, this FFWS is not functioning well with problems as presented in Table 9.

**Table 9 Situation of the Existing 14 Gauging Stations of FURB/CEOPS**

Existing Stations			Situation of Stations
1	Taio	Rainfall/Water Level	Transmission system needs to be improved.
2	Rio Oeste	Rainfall/Water Level	Monitoring equipment is not functional, GSM is defective, and there is no one in charge for its maintenance.
3	Saltinho	Rainfall/Water Level	Monitoring equipment is not functional, GSM is defective, and there is no one in charge for its maintenance.
4	Ituporanga	Rainfall/Water Level	Transmission system needs to be improved.
5	Rio do Sul	Rainfall/Water Level	Operational
6	Barra da Prata	Rainfall/Water Level	Monitoring is not executed on time due to the failure of monitoring equipment and absence of persons in charge for its maintenance.
7	Ibirama	Rainfall/Water Level	Transmission system needs to be improved.
8	Apiuna	Rainfall/Water Level	Though residents around the station observe water level because of the failure of the sensor and telemetry, they now stop due to delinquency of administration payment from CEOPS.
9	Timbo	Rainfall/Water Level	Operational
10	Indaial	Rainfall/Water Level	Monitoring equipment is not functional, GSM is defective, and there is no one in charge for its maintenance.
11	Blumenau	Rainfall/Water Level	Operational
12	Salseiro	Rainfall/Water Level	GSM transmission system is defective.
13	Botuvera	Rainfall/Water Level	GSM transmission system is defective.
14	Brusque	Rainfall/Water Level	Water level gauging sensor is not functional due to sedimentation.

Source: JICA Study Team

## 5. Basic Strategy for Formulation of the Flood Mitigation Master Plan

### 5.1 Needs for Flood Mitigation of Each City

Table 10 summarizes the flooding characteristics and issues peculiar to major cities based on the results of discussions with various government institutions and universities as well as site visits.

**Table 10 Flooding Characteristics and Issues of Each City along the Itajaí River**

City	Population	Results of Interview and Site Visits	Source of Information
Itajaí River			
Itajaí	172,081	<ul style="list-style-type: none"> <li>Flood damages have occurred seven times since 1980.</li> <li>Many affected residents due to its large population</li> </ul>	Reports
		<ul style="list-style-type: none"> <li>In the urban area, flooding of Itajaí Mirim River is more severe than Itajaí River.</li> <li>The rising of water level of Itajaí River and tidal level blocks the drainage of Itajaí Mirim River.</li> <li>The drainage system is vulnerable, and there are no pumping stations</li> <li>The bridge over Itajaí Mirim River influences the flow capacity.</li> <li>There is an alarm system, but it is not satisfactory like that in Blumenau City.</li> <li>There is an APP plan (green belt along the old Itajaí Mirim River).</li> </ul>	Planning and Construction Department of Municipal Government and UNIVALI Site Visit
		<ul style="list-style-type: none"> <li>The high sediment inflow into the port requires annual dredging of huge volumes of sediment.</li> <li>Necessity of measures to reduce sediment production in the basin.</li> </ul>	Itajaí Port Site Visit
Navegantes	57,324	<ul style="list-style-type: none"> <li>Less frequent flooding (three times since 1980).</li> <li>Small-scale flood damages due to higher ground elevation.</li> <li>Necessity of measures to sedimentation problem at the port.</li> </ul>	Reports Planning and Financial Departments Site visit
Ilhota	12,149	<ul style="list-style-type: none"> <li>Less frequent flooding (twice since 1980 based on the report, but five times according to the municipal government).</li> <li>There are lowlands along the state highway SC-470 where frequent flooding occurs due to poor drainage.</li> <li>There is a plan to build a new bridge over Itajaí River.</li> </ul>	Reports Planning Department of Municipal Government
Gaspar	55,489	<ul style="list-style-type: none"> <li>Flood damages have occurred seven times since 1980 wherein many residents were affected.</li> <li>The river is narrow in the urban area, and the existing bridge in the city significantly prevents the flow area in the river channel.</li> </ul>	Reports Site visit
Blumenau	299,416	<ul style="list-style-type: none"> <li>Flood damages have occurred 14 times since 1980 wherein many residents were affected.</li> <li>The 1983 and 1984 floods caused inundation with the gradual increase of water level of the main stream of Itajaí River.</li> <li>In the 2008 flood, Itajaí River did not overflow, however there were damages caused by flash floods in its tributaries (i.e. Garcia, Velha, Fortaleza Rivers).</li> </ul>	Reports Site visit
		<ul style="list-style-type: none"> <li>Residential development on mountainous areas have caused flash floods and landslides, and there are many illegal settlers along the river.</li> <li>There are plans to construct a bridge, revetment, drainage facilities and water gate with pumping stations in tributaries (i.e. Fortaleza, Garcia, Velha, and Itoupava Rivers)</li> <li>Urban development will expand to the northern area in the future (Itoupava River).</li> <li>At present, there is no flooding problem in the Itoupava River.</li> <li>Flood warning is announced based on information from CIRAM and FURB/CEOPS through radio and internet, and CEOPS forecasts the river water level six hours ahead.</li> </ul>	Planning and Construction Department of Municipal Government Site visit



City	Population	Results of Interview and Site Visits	Source of Information
		<ul style="list-style-type: none"> <li>The potential of flood damage has increased due to illegal settlers along rivers.</li> <li>Banks and houses are likely to collapse along the sandy bank without vegetation.</li> <li>According to environmental law, the committee plans to afforest a 30 m wide protection area on river banks and considers that riparian forests is very important in terms of flood control.</li> <li>It is a problem to install the water gate at the mouth of the Fortaleza River.</li> <li>The project of the municipal government of Blumenau to install concrete revetment on the left bank of the Itajaí River will have no effect on flood control, and will only lose valuable vegetation on the river bank.</li> </ul>	Itajaí River Basin Committee and FURB Site visit
Indaial	50,917	<ul style="list-style-type: none"> <li>Less frequent flooding (three times since 1980 but of small scale).</li> <li>The flow capacity of the Itajaí River is large.</li> </ul>	Reports Site visit
Ascurra	10,996	<ul style="list-style-type: none"> <li>No flood damage has occurred.</li> </ul>	Reports Site visit
Apiúna	6,945	<ul style="list-style-type: none"> <li>No flood damage has occurred.</li> </ul>	Reports Site visit
Lontras	9,660	<ul style="list-style-type: none"> <li>Less frequent flooding (three times since 1980 but of small scale).</li> </ul>	Reports Site visit
Rio do Sul	59,962	<ul style="list-style-type: none"> <li>Although the affected population is small, flood damage has occurred frequently (eight times since 1980).</li> </ul>	Reports Site visit
		<ul style="list-style-type: none"> <li>Small-scale flooding have occurred frequently (two to three times per year).</li> <li>There are many problems with regards to illegal settlers and land use.</li> <li>There are operations problems at Oeste and Sul Dams.</li> <li>Information from the dams (reservoir level, outflow, etc.) are insufficient (e.g. the outflow of the dam is unknown at the dam office).</li> <li>It is very difficult to widen the river channel in the urban area.</li> <li>An evacuation manual is being prepared.</li> </ul>	Planning Department of Municipal Government and Civil Defense Site visit
		<ul style="list-style-type: none"> <li>A project on retaining rainwater in paddy fields is being prepared.</li> <li>There is also a plan to store river water in paddy fields through small dams at small tributaries.</li> </ul>	CRAVIL Site visit
<b>Itajaí Mirim River</b>			
Brusque	102,280	<ul style="list-style-type: none"> <li>Less frequent flooding (three times since 1980).</li> <li>Recently, there have been less flooding problems due to river improvement.</li> <li>There has been no flooding in the urban area except during the 1984 flood wherein the roads were inundated.</li> <li>Bank erosion at the colliding portion of meandering channel might cause impact to residences on the river bank.</li> </ul>	Planning Department of Municipal Government and Site visit
<b>Benedito River</b>			
Timbó	35,303	<ul style="list-style-type: none"> <li>Although the affected population is small, flood damage has occurred frequently (six times since 1980).</li> <li>Due to the abrupt releasing of water from the upstream of two hydropower generation dams at the Rio dos Cedros River, flooding frequently occurs.</li> <li>In June 2010, the City Councils of Timbo and Rio dos Cedros jointly submitted a petition to the Governor containing the signatures of 1,200 residents that requires the lowering of the normal operations reservoir water level.</li> <li>In addition to the flood from the Benedito River, flooding from the Rio dos Cedros River joins with it.</li> </ul>	Report DEINFRA FURB/CEOPS City Council Site visit
Benedito Novo	10,335	<ul style="list-style-type: none"> <li>No flood damage has occurred.</li> </ul>	Report and site visit

City	Population	Results of Interview and Site Visits	Source of Information
Rio dos Cedros	10,170	<ul style="list-style-type: none"> <li>• Same as Timbó City, frequent flooding has occurred due to the abrupt releasing of water from the upstream of two dams at the Rio dos Cedros River.</li> <li>• In June 2010, the City Councils of Timbo and Rio dos Cedros jointly submitted a petition to the Governor containing the signatures of 1,200 residents that requires the lowering of the normal operations reservoir water level</li> <li>• When the water depth of the Rio dos Cedros River exceeds 6 m, flooding starts in the urban area. Mapping of flood inundation areas in the city has been completed.</li> </ul>	Report FURB/CEOPS Mayor of the city and the city council Site visit
Itajaí do Norte River			
Ibirama	17,469	<ul style="list-style-type: none"> <li>• No flood damage has occurred.</li> </ul>	Report Site visit
Itajaí do Oeste River			
Laurentino	5,757	<ul style="list-style-type: none"> <li>• Almost no flood damage has occurred.</li> </ul>	Report
Rio do Oeste	7,033	<ul style="list-style-type: none"> <li>• Almost no flood damage has occurred.</li> </ul>	Report
Taio	17,522	<ul style="list-style-type: none"> <li>• Although the affected population is small, flood damage has occurred frequently (six times since 1980).</li> <li>• Taio City is prone to inundation due to the potential overflow of Oeste Dam.</li> <li>• The urban area near the city hall was inundated at a depth of around 1.5 m during the April 2010 flood. There have been opinions that the inundation was due to the early closure of the gates at the dam.</li> <li>• The current flow capacity is around 1,000 m<sup>3</sup>/s. However, the maximum releasing capacity under fully opened condition of gates at Oeste Dam is around 160 m<sup>3</sup>/s.</li> </ul>	Report DEINFRA Site visit
Trombudo	6,520	<ul style="list-style-type: none"> <li>• Less frequent flooding (three times since 1980 but of small scale).</li> </ul>	Report and Site visit
Itajaí do Sul River			
Ituporanga	21,496	<ul style="list-style-type: none"> <li>• Less frequent flooding (twice since 1980 but of small scale).</li> </ul>	Report and Site visit

Source: JICA Survey Team

## 5.2 Basic Principles for Planning

As stated in the minutes of the meeting on November 5, 2009, the basic principles of the preparatory survey for planning the master plan on the prevention and mitigation of natural disasters were established as follows:

- i) To avoid negative impacts on the natural and social environment, especially involuntary resettlement and biodiversity loss,
- ii) To avoid adverse effects at the downstream reaches of the river from the sites subject to countermeasures such as increase of flood velocity and discharge that might cause bank erosion and flooding,
- iii) To enrich rainwater storage function of each river subbasin in order to delay quick flood runoff, and
- iv) To promote multiple use of the existing hydraulic structures and spaces in the basin.

## 5.3 Basic Strategy for Formulation of Master Plan

Based on the basic principles mentioned above and the results of discussions between various government institutions, universities and the Itajaí River Basin Committee, the basic strategy for formulating a master plan on flood prevention was set up as follows:

- i) Since it was considered difficult to set up the target flood security level in the master plan, four levels of flood prevention master plans are to be proposed at the moment for the selected target regions for protection. The master plans to be created consider the levels of

- the 5-, 10-, 25- and 50-year floods. Then, the flood security level will be selected through discussions with the Itajaí Basin Committee as well as the state government (governor and state secretaries).
- ii) In addition, the selection of target regions for flood protection, combination of flood control alternatives and their flood control effects will be discussed with the Itajaí River Basin Committee (technical subcommittee on flood prevention).
  - iii) A master plan for flood prevention will be formulated taking into consideration the ongoing concept of comprehensive flood control measures in Japan, which aim to prevent the concentration of flood runoff from various river basins. “Flood control measures to scatter flood” will be given high priority in the formulation of a master plan by minimizing flood damages allowing flood inundation.
  - iv) Temporary retention of rainwater in paddy fields and small retention ponds (small irrigation dam) that are proposed in the Water Resources Management Master Plan for the the Itajaí River Basin might be able to hinder the concentration of flood runoff to the downstream reaches and therefore subject to examination. According to CRAVIL, the target paddy area for retention is around 27,000 ha in total along the Itajaí River from the upstream reaches of Rio do Sul City to Itajaí City.
  - v) Among the existing three flood control dams, the increase of flood control capacity by heightening of Oeste and Sul Dams also may contribute to delay the concentration of the flood runoff to the downstream reaches (especially effective for flood mitigation in Taio and Rio do Sul Cities located at the downstream reaches of the dams).
  - vi) The existing flood plain spreading from Gaspar City to Itajaí City, which acts as a natural retarding basin, is currently used for agricultural land and pasture. This flood plain shall be preserved without land developments because it contributes to the reduction of flood flow at the downstream areas.
  - vii) With regards to the target region for flood prevention, Rio do Sul, Blumenau and Itajaí Cities might be of higher priority. In addition to delaying the concentration of flood runoff as much as possible by provision of various measures in the upper basins, possible flood control alternatives will be conceived for comparison duly considering current flood inundation characteristics and the existing urban plan (land use plan).
  - viii) In addition to the flood from the main stream of the Itajaí River, flood inundation in Itajaí City is due to backwater to the Itajaí Mirim River from the Itajaí main stream (added by tidal influence), poor drainage system in the urban area, and flood inflow from the Itajaí Mirim River. Flood control measures will be created based on the evaluation of these impacts.
  - ix) As for measures against flash floods, adjustment of the urban plan (land use regulation and zoning) might be necessary since there are many illegal settlers on the river banks.
  - x) When a higher security level such as a 50-year flood prevention plan is required, basin measures to scatter floods would be limited from the aspects of flood control effects. In such case, the widening of river channel by providing a composite section will be necessary. Regarding the utilization of the high water channel of the composite section, the program of riparian forest rehabilitation under the Water Resources Management Master Plan of the Committee will be incorporated into the master plan. In addition, a floodway is likely to be required as an alternative to reduce the duration and depth of flood inundation at the flood plain downstream from Gaspar City and the urban area of

Itajaí City.

- xi) The target year of the flood prevention master plan depends on the selected flood security level. In order to ensure consistency with the target year of 2030 as proposed in the long-term plan of the Water Resources Management Master Plan for the Itajaí River Basin, a master plan on flood prevention should be achieved by 2030 at the latest.

#### 5.4 Basic Strategy for Strengthening of Existing FFWS

Considering the current problems of the existing FFWS for the Itajaí River basin, a plan to strengthen the existing FFWS will be formulated based on the following basic strategies:

- i) Strengthening of the existing hydrometeorological observation network with provision of additional gauging stations, and
- ii) Improvement of the accuracy of observed data and data transmission by updating observation equipment and data transmission method.

### 6. Basic Strategy for Formulation of Landslide Management Master Plan

#### 6.1 Actual State of Landslide Disasters and Restoration Works

Figure 8 shows the number of landslide disaster events within the Itajaí River basin. This is based on Defesa Civil-SC data recorder at a span of 23 years from 1980 to 2003 in the State of Santa Catarina. There is a total 65 landslide disaster events in the Itajaí River basin. This number corresponds to 35% of the total 185 landslide disaster events that occurred in the entire state.

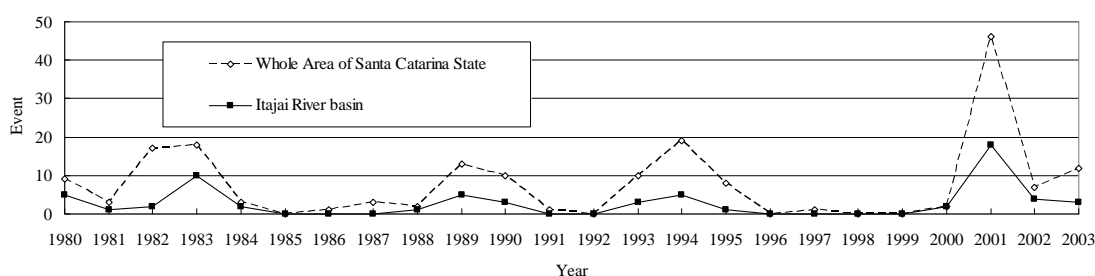

Source : Prepared by JICA Study Team on the basis of Defesa Civil-SC Data

**Figure 8 Number of Landslides in the State of Santa Catarina and in Itajaí River Basin from 1980 to 2003**

The area of Itajaí River basin accounts for 16% of the land area of the entire state. The annual number of landslide events per thousand km<sup>2</sup> is 0.85 events/1,000 km<sup>2</sup>/yr in the entire state and 1.9 events/1,000 km<sup>2</sup>/yr in the Itajaí River basin. This indicates that landslide disaster events in the Itajaí River basin is relatively high, and 2.2 times of those in the entire State of Santa Catarina.

The heavy rains in November 2008 caused serious damages due to landslides and floods. The 89 deaths represent 0.09% of the 103,602 evacuated persons, 0.13% of the 66,556 affected persons, and 0.61% of 14,573 persons who lost their homes. The official reports did not give the breakdown of the numbers of victims caused by floods or by landslides. According to the Defesa Civil-SC, 97% of deaths were caused by landslides. The expenses of the State of Santa Catarina for emergency activities such as evacuation, infrastructure rehabilitation, etc. totalled to R\$520 million. The total cost of the complete restoration works for the Federal BR470 Road amounted to R\$17 million.

## 6.2 Evaluation of Landslide Risk and Risk Mapping

Potential landslide locations were identified based on past disaster records, site reconnaissance and topographical interpretations (1:50,000 topographical maps, 1:25,000 topographical map of Ilhota City, and aerial photos taken in 1978 and 1979). There are a total of 949 potential landslide locations that were identified.

A landslide site that has high potential for a landslide to occur and with potential damage amounting to more than R\$1 million of annual loss at 60-year probable rainfall was selected as the priority landslide risk site. The potential annual loss of over R\$1 million is roughly defined to be damage with complete collapse of more than ten houses or complete closure of a road with over 200 daily traffic volume. Consequently, 68 priority landslide risk sites were selected for further study. These include 32 sites along roads in the State of Santa Catarina, 35 sites along the municipal roads, and one site around the port of Itajaí City.

For the 68 selected priority landslide sites, the risk was quantitatively evaluated in terms of potential annual loss. For the same landslide site, the scale of landslide disaster (sediment volume reaching target facilities, section length of affected roads, deposited sediment volume in port, etc.) depends upon the probability of landslide occurrence, and scale of triggering factors such as rainfall. In the case of road damage, possibilities of non-exceedance of landslide occurrences and the potential loss are first calculated and then the potential annual loss are determined considering two kinds of damage scale, namely, complete closure and partial closure (one lane closure). The possibility of non-exceedance of complete and partial closures was evaluated on the basis of the scale (volume) of landslide disaster similar to the rainstorm of November 2008, and the estimated probability of soil humidity index closest to the landslide site.

Figure 9 shows the distribution of the priority landslide risk sites with different levels of potential annual loss in the Itajaí River basin. An example of priority landslide risk maps is shown in this figure. The base map is composed of 239 sheets with 1:30,000 Itajaí topographical maps in A3 size. Each site has GIS information as listed in Table 11.

**Table 11 Inventory Item of Landslide Risk Site**

Regional number of landslide risk site (Map code + Serial number)
Location (Longitude and latitude of central point of the target site)
SDR/Municipality
Type of Movement
Risk Area (Fall, Collapse, Movement, Runoff of mud, etc.)
Type of Geology, Soil, Vegetation
Classification of Elevations, Gradients

Source: JICA Survey Team

## 6.3 Needs of Landslide Disaster Mitigation

In the study area, due to repeated floods and increased population, the construction of residential areas expands into inclined areas or slopes. This increases the risk of landslide disasters. Damaged areas are due to multiple human factors such as uncontrolled residential area construction (steep cut slope, residence in flooding area, poor drainage, etc.). Accordingly, the civil defense of municipalities is requesting technical support and training related to management and control of landslide disasters. In addition, the State Civil Defense and other entities also have similar requirements. On the other hand, DEINFRA has addressed the needs of implementing landslide prevention projects, such as those that include structural measures along state and municipal roads.

### 6.4 Basic Principles for Landslide Mitigation Measures

The master plan for landslide mitigation was formulated based on the following principles:

- i) Introduction of structural and nonstructural works
- ii) Care for vulnerable people
- iii) Environment-friendly comprehensive landslide disaster measures

### 6.5 Basic Strategy for Formulating the Master Plan of Landslide Disaster Mitigation

The basic strategies for the formulation of the master plan were determined as follows:

- i) For nonstructural measures, forecast and warning systems against landslides and floods were installed for the entire State of Santa Catarina.
- ii) Structural measures will be prioritized to landslide sites with the highest level of potential annual loss.
- iii) In the implementation of nonstructural and structural measures, it should be addressed to conduct technology enhancement for relevant organizations and disaster education for related organizations and residences.

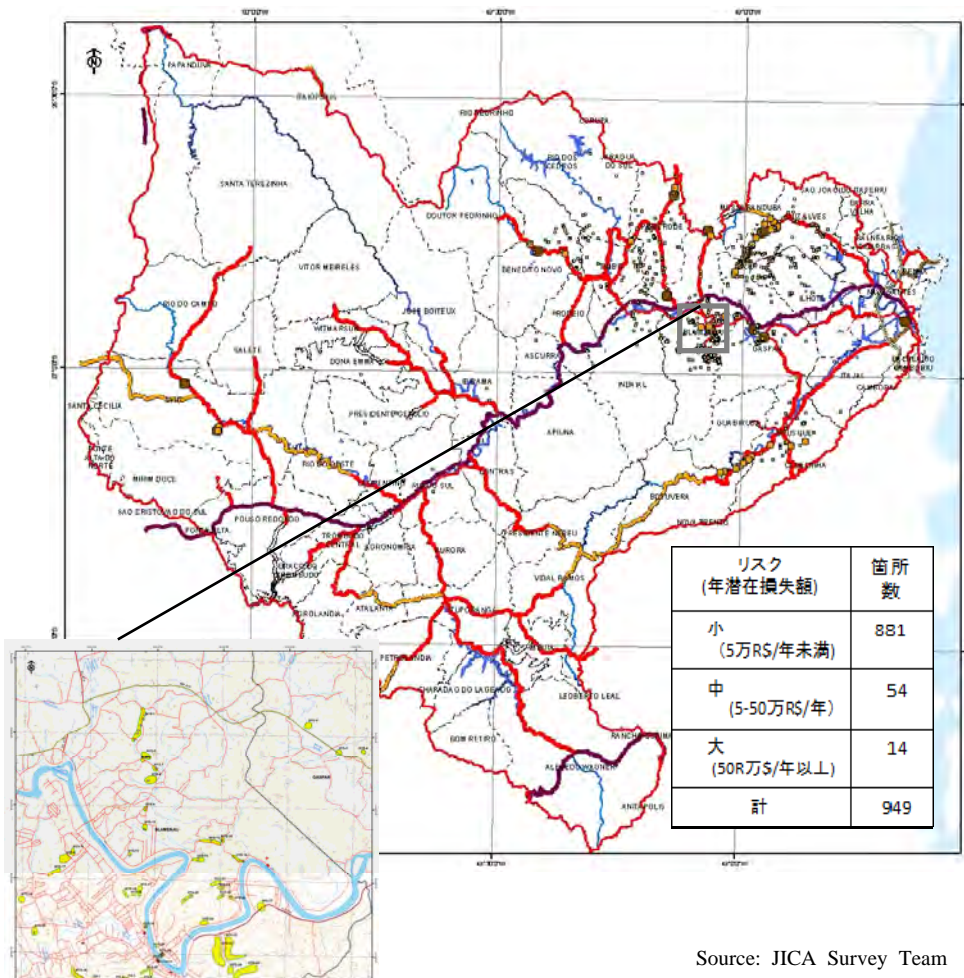

Figure 9 Map of Priority Landslide Risk Sites and Example of Priority Landslide Risk Maps



## **7. Environmental and Social Consideration and Strategic Environmental Assessment**

### **7.1 Strategic Environment Assessment (SEA)**

The objectives of the JICA Guidelines for Environmental and Social Considerations (the New Guidelines, April 2010) are the following: i) to encourage the project proponents, etc., ii) to have appropriate consideration for environmental and social impacts, and iii) to ensure that JICA's support for, and examination of, environmental and social considerations are conducted accordingly. The guidelines give an outline of JICA's responsibilities and procedures, along with its requirements for the project proponents in order to facilitate the achievement of these objectives. In doing so, JICA endeavors to ensure transparency, predictability, and accountability in its support for, and examination of, environmental and social considerations.

The first phase of the preparatory survey is the master plan study. An initial environmental examination (IEE) was carried out following the principle of the SEA, which is to "integrate the environmental and social consideration into decision making through the strategy of planning process", in the process of formulating the flood mitigation plan and the sediment disaster management plan.

### **7.2 Law of Conservation Units (SNUC Law)**

Protected areas, such as national parks in Brazil, are called "conservation units" (Unidades de Conservação (UC)). It is legislated by SNUC Law (Federal Law No. 9,985/00). Other than the SNUC law, other important laws on protected areas are the Forest Code and the Animal Conservation Law. There are two types of protection units, namely, integrated protection units and sustainable use Units.

The Forest Code was established in 1965 to protect forest and native vegetation from unregulated development. This code is a major law in the Brazilian Federal Law. It is complicated to revise, thus there is no major revision although there are some additional articles. At present, a major revision to the Forest Code is under process in the Senate, and it will be implemented this year. In the Forest Code, the "Permanent Preserve Area (Área Preservação Permanente (APP))" and "Legal Reserve (Reserva Legal (RL))" were legislated.

## **8. Formulation of the Master Plan on Flood Management**

### **8.1 Flood Safety Level**

Master plans on flood mitigation were separately formulated with different flood safety levels (5-, 10-, 25- and 50-year floods).

### **8.2 Selection of Cities for Flood Protection**

Flooding and inundation resulting from floods occur in the regions along the Itajaí River and its tributaries. It is considered unrealistic from the economic and financial points of view to implement a flood control project to protect all areas subject to habitual flooding and inundation in the Itajaí River basin. The Itajaí River Basin Committee shared the same opinion. A river improvement project by installing dykes tends to become costly due to drastic increase of flood discharges at the downstream reaches resulting from upstream river improvement works by dykes. In order to avoid such increase of project cost, areas with low flood damage potential along the river such as pastures, paddies and dry fields should be actively maintained in the current condition, intentionally with no dykes provided for protection. In this regard, target areas subject to flood protection will be the major cities along the Itajaí River.

Eight cities were selected at higher priority for flood mitigation considering the frequency and

damages caused by floods and the results of various visits and interviews to municipal governments. The selected cities are Rio do Sul, Blumenau, Gaspar, Ilhota, Timbó, Taió, Itajaí and Brusque. As for the measures against flash floods, urban streams in Blumenau City (Garcia and Velha Rivers) were selected as the target rivers, where urban developments on the hill slope together with residential development along the stream have been in progress in recent years. This results to an increase of damage potential due to flash floods.

### 8.3 Selection of Flood Control Alternatives

Taking into consideration the current condition of river canal, flood inundation situation and topographic conditions, various alternatives of flood control measures that would be applicable to the Itajaí River basin were proposed as summarized in Figure 10.

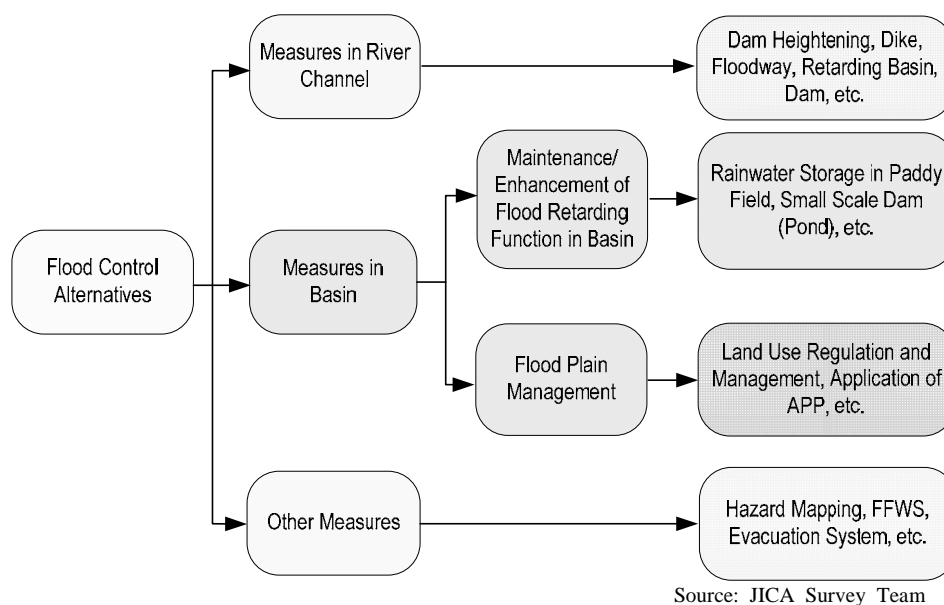

**Figure 10 Flood Control Alternatives Applicable to Itajaí River Basin**

For both Oeste and Sul Dams, reinforcement by means of the following measures in order to increase flood control capacity is being considered:

- i) Oeste Dam: Heightening of the existing dam body and spillway
- ii) Sul Dam: Heightening of the existing spillway

As for Sul Dam, which is a rockfill type dam, heightening the existing spillway was examined because it is technically difficult to heighten the dam body. With the reinforcement of the two dams, the flood control effect (reduction of the flood peak discharge) would be expected in Rio do Sul City as well as in major cities downstream along the Itajaí River.

In order to increase the current flow capacity of the river channel, river widening and riverbed excavation are most commonly applied for flood control projects. In the flood control master plan formulated by JICA in 1988, widening and riverbed excavation of the river channel were proposed in the stretches between Blumenau and Gaspar Cities in the Itajaí River. However, these measures are not to be applied as much as possible for the main stream of the Itajaí River under the current study. Nevertheless, river widening with provision of composite section preserving the existing riparian forest is included in the flood control alternatives, because it is inevitably required to increase the current flow capacity when a higher flood safety level is required.

Figure 11 illustrates the image of the composite section of the Itajaí River. As shown in this figure, when river widening is applied to the composite section, the current riparian forest will

be preserved to be used as a park or open space. Furthermore, the existing road will be utilized as dyke (including raising of the road) or the proposed new road will be used as dyke. In this regard, the current river channel forms a low water channel of the composite section.

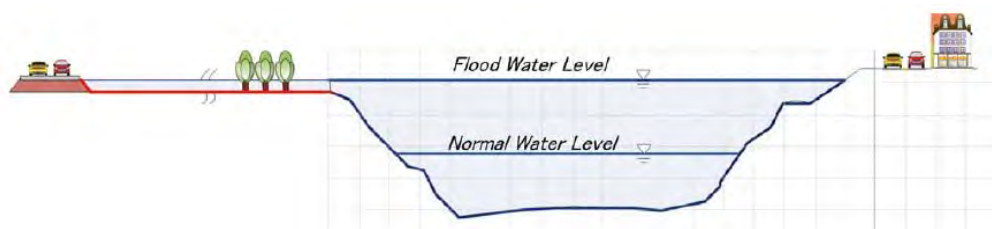

Source: JICA Survey Team

**Figure 11 Illustration of the Composite Section in Blumenau City**

The flood control master plan in 1988 proposed a floodway to divert part of the large flood discharge of the Itajaí River to the Atlantic Ocean crossing Navegantes City from the immediate downstream reaches of the bridge of BR 101, considering that it was very difficult to widen the river channel and provide dikes on both banks to increase the flow capacity in order to pass the flood. The floodway is added as a flood control alternative because it is expected to reduce the depth and duration of flood inundation that is likely to occur widely over the alluvial plain spreading from Gaspar City.

CRAVIL has a plan to build water storage in the existing paddy fields in order to store rainfall water in the existing paddy fields, which covers an area of 22,000 ha. According to the plan, the furrows of the paddy field having an average height of 10 cm are to be raised by 20 cm. At the maximum, the paddy fields are expected to store 66 million m<sup>3</sup> of rainfall.

Small dams are planned to be installed at small tributary rivers as basin storage. The stored water is to be utilized for irrigation on micro basin basis. The selection of small dam sites will be highly prioritized to micro basins in the Itajaí do Oeste and Sul Rivers, as shown in Figure 12.

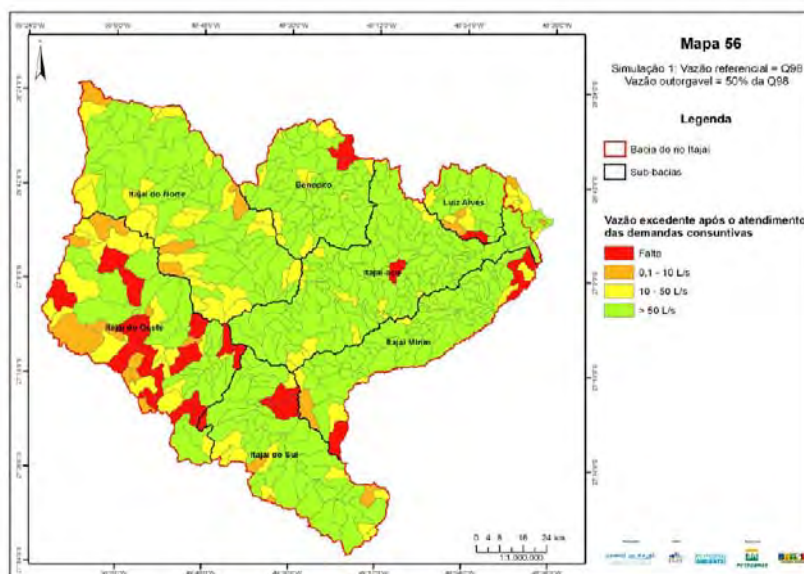

Source : Itajaí River Basin Committee

Figure 12 Micro Basin of Water Shortage for Irrigation in the Itajaí River Basin

#### 8.4 Flood Mitigation Master Plan by Safety Level

Tables 12 and 13 summarize the components and general features of the plans for respective flood safety levels. Figure 23 shows a location map of the flood mitigation plan for a 50-year flood.

Table 12 Flood Mitigation Plans by Safety Level

Measures	Projects	5-year	10-year	25-year	50-year
Basin Storage Measures	Water storage in paddy fields	✓	✓	✓	✓
	Basin storage (small dams)	✓	✓	✓	✓
	Heightening of the dam (Oeste Dam)			✓	✓
	Heightening of the spillway (Sul Dam)				✓
	New flood control dam (Itajaí Mirim River)				✓
	Improve operation of Oeste and Sul Dams	✓	✓	✓	✓
	Preventive discharge at the hydro-electric generation dams (two dams)		✓	✓	✓
River Improvement Measures	Itajaí River, Rio do Sul City stretch			✓	✓
	Itajaí do Oeste River, Taió City stretch			✓	✓
	Benedito River, Timbó City stretch			✓	✓
	Itajaí River, Blumenau City stretch				✓
	Ilhota City, ring dyke			✓	✓
	Garcia and Velha Rivers in Blumenau City	✓	✓	✓	✓
	Itajaí River improvement in Itajaí City		✓	✓	
	Floodway in Itajaí and Navegantes Cities				✓
	Floodgates and river improvements for the Itajaí Mirim River in Itajaí City	✓	✓	✓	✓

Source: JICA Survey Team

Table 13 Components of Flood Mitigation Plans by Safety Level

Measures	Projects	5-year	10-year	25-year	50-year
Basin Storage Measures	Containment of water in rice fields	22,000 ha	22,000 ha	22,000 ha	22,000 ha
	Basin storage (small dams)	2 units	5 units	7 units	7 units
	Heightening of the dam (Oeste Dam)			2 m	2 m
	Heightening of the spillway (Sul Dam)				2 m

	New flood control dam (Itajaí Mirim River)				1 unit
	Improve operation and functioning of dams (two dams)	2 dams	2 dams	2 dams	2 dams
	Preventive discharge at the hydroelectric generation dams (two dams)		2 dams	2 dams	2 dams
River Improvement Measures	Itajaí River, Rio do Sul City stretch			Excavation 10.3 km	Dykes 8.1 km
	Itajaí de Oeste River, Taió City stretch			Excavation 3.7 km	Dykes 3.7 km
	Benedito River, Timbó City stretch			Excavation 1 km	Dykes 1 km
	Itajaí River, Blumenau City stretch				Dykes 15.8 km
	Ilhota City, ring dykes			8 m	8 km
	Garcia and Velha Rivers in Blumenau City	Excavation /Dyke 7.0 km	Excavation /Dyke 7.0 km	Excavation /Dyke 7.0 km	Excavation /Dyke 7.0 km
	Itajaí River in Itajaí City		Dykes 12.8 km	Dykes 12.8 km	
	Floodway in Itajaí/Navegantes Cities				10.9km
	Floodgates and flow improvements for the Itajaí Mirim River in Itajaí City	2 floodgates and 0.95 km dykes	2 floodgates and 0.95 km dykes	2 floodgates and 0.95 km dykes	2 floodgates and 0.95 km dykes

Source: JICA Survey Team

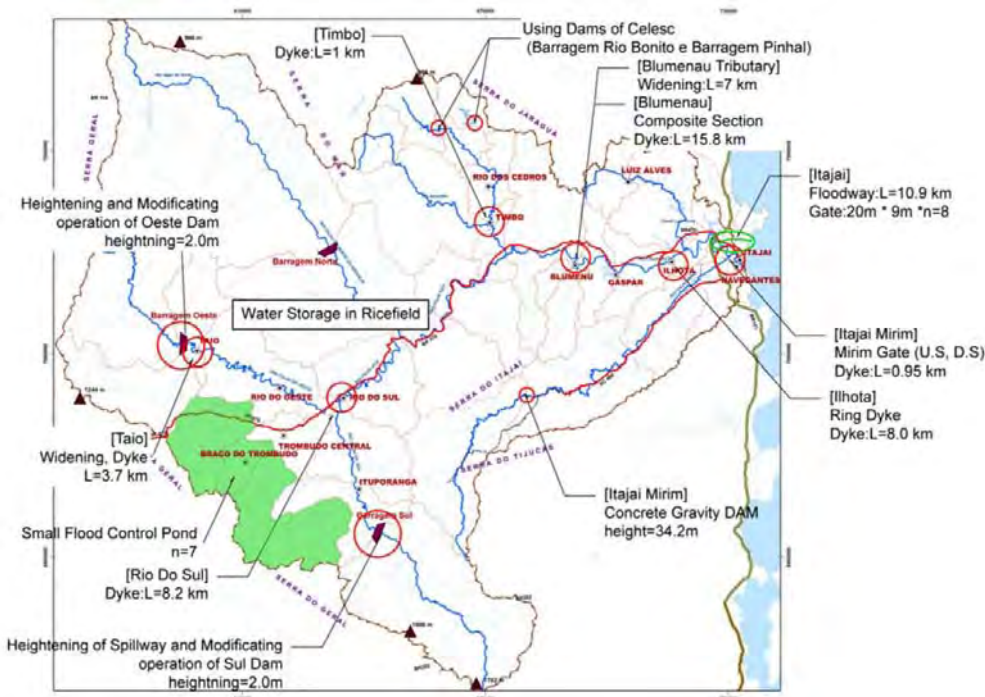

Source: JICA Survey Team

**Figure 13 Location Map of the Mitigation Plan for 50-year Flood**

It is important to note that the respective plans were formulated independently. Especially, for both the 10- and 25-year flood plans, dyke construction on the right border of the Itajaí River was proposed. However, for the 50-year flood plan, a floodway was proposed instead of dykes. The construction of dykes on the right bank will not be implemented to avoid future conflict at the stage-wise implementation of the project. On the other hand, in terms of flood control, the floodway that is being proposed for the 50-year flood plan also affects the 5-, 10- and 25-year plans, and the construction of the dyke becomes unnecessary. In conclusion, the floodway is proposed in Phase 2 of implementation.

## 8.5 Strengthening Plan of Existing FFWS

The existing meteorological and hydrological monitoring network of FFWS consists of 14 rainfall/river water level gauging stations. However, these gauging stations are not sufficiently maintained, thus the equipment used for observation and transmission are currently not functioning properly. Replacement of equipment and the introduction of reliable transmission systems at these stations will be prioritized. Based on the discussion with SDS, it was informed that the improvement of these existing stations would be implemented using the budget of SDS. Since the existing gauging stations are suitably located at the most important locations for FFWS, improvement of the existing stations must be surely implemented.

As shown in Table 14, additional 16 gauging stations were proposed to be installed at the existing observation network of FFWS in order to improve the accuracy of flood forecasting.

**Table 14 Proposed New Gauging Stations for Flood Forecasting Warning System**

Proposed Gauging Station			Purpose of Monitoring
1	Ituporanga (Perimbo River)	Rainfall/River Water Level	Warning for Ituporanga, Rio do Sul
2	Salete (Grande River)	Rainfall/River Water Level	Warning for Salete, Taio
3	Mirim Doce (Taio river)	Rainfall/River Water Level	Warning for Mirim Doce
4	Pouso Redondo (das Pombas River)	Rainfall/River Water Level	Warning for Pouso Redondo, Rio do Sul
5	Trombudo (Trombudo River)	Rainfall/River Water Level	Warning for Trombudo, Agronomica, Rio do Sul
6	Rio do Sul (Itajaí River)	CCTV	Monitoring the situation of the river in Rio do Sul
7	Rio dos Cedros (dos Cedros River)	Rainfall/River Water Level	Warning for Apiuna
8	Vidal Ramos (Itajaí Mirim River)	Rainfall/River Water Level	Warning for Vidal Ramos
9	Palmeiras Power Station (dos Cedros River)	Rainfall/River Water Level	Monitoring the discharge from Celesc Dam, and early warning for Rio dos Cedros, Timbo
10	Blumenau (Itajaí River)	CCTV	Monitoring the situation of the river in Blumenau
11	Luis Alves (Luis Alves River)	Rainfall/River Water Level	Warning for Luis Alves, collecting meteoro-hydrological data in the Luis Alves River basin
12	Gaspar (Itajaí River)	Rainfall/River Water Level	Warning for Gaspar, collecting flood water level in the flood plane
13	Ilhota (Itajaí River)	Rainfall/River Water Level	Warning for Ilhota, collecting flood water level in the flood plane
14	Itajaí (Itajaí River)	CCTV	Monitoring the situation of the river in Itajaí
15	Guabiruba (tributary of Itajaí Mirim River)	Rainfall/River Water Level	Warning for Guabiruba
16	Agua Clara (tributary of Itajaí Mirim River)	Rainfall/River Water Level	Warning for Agura Clara
<b>Totally 13 Gauging Stations (Rainfall/River Water Level), 3 CCTV Stations</b>			

Source: JICA Survey Team



## 9. Formulation of Master Plan for Landslide Management

### 9.1 Contents of Master Plan

Table 15 shows the contents of the master plan on landslide management.

**Table 15 Contents of Master Plan to Mitigate Landslide, Sediment Yield, and Flash Flood**

Purpose	Measures	Description in the Master Plan
Avoid the loss of human lives	(1) Nonstructural measures (Implementation of early warning systems for landslide and flash flood) a) Formulation of system for monitoring/repository of rainfall data and communication of warning information. b) Disaster education and drills to the persons in charge and residents for reliable evacuation.	Plan including cost estimation is prepared as a main measure project.
Reduce economic losses	(2) Structural measures against landslide Structural measures will be implemented at the priority sites which have high potential annual loss.	
	(3) Mitigation of sediment yield Forestation of bare collapsed land and prevention of riverbank erosion by river bank forest will be promoted. Prevention of sediment yield will be secured by vegetation at the sites where structural measures against landslide are installed.	Detailed plan is not formulated in the master plan; the issues are treated in watershed/ forest conservation plans.
	(4) Mitigation of flash flood Installation of discharge regulation facilities for rainfall runoff will be promoted in order to mitigate floods and flash floods.	Detailed plan is not formulated in the master plan; the issues are treated in regional planning.
	(5) Capacity building for structural measure and support for private independent efforts a) Capacity building for structural measure projects b) Support for private independent efforts Disaster education and subsidy of official/private fund will be promoted for private sectors in order to reduce damage of private preservation objects which have low priority and potential annual losses.	The master plan describes necessity as political policy.

Source: JICA Survey Team

### 9.2 Nonstructural Measures (Early Warning Systems for Landslide and Flash Flood)

Defesa Civil-SC conducts general management and the official issue of early warnings. Municipal governments order the evacuation of residents and traffic regulation of municipal roads. DEINFRA orders traffic regulation of roads in the State of Santa Catarina. SDRs order the suspension of classes at schools under the supervision of SDRs in case of an emergency or alarm issuance. The outline of the proposed early warning systems for landslides and flash floods are shown in Figure 14.

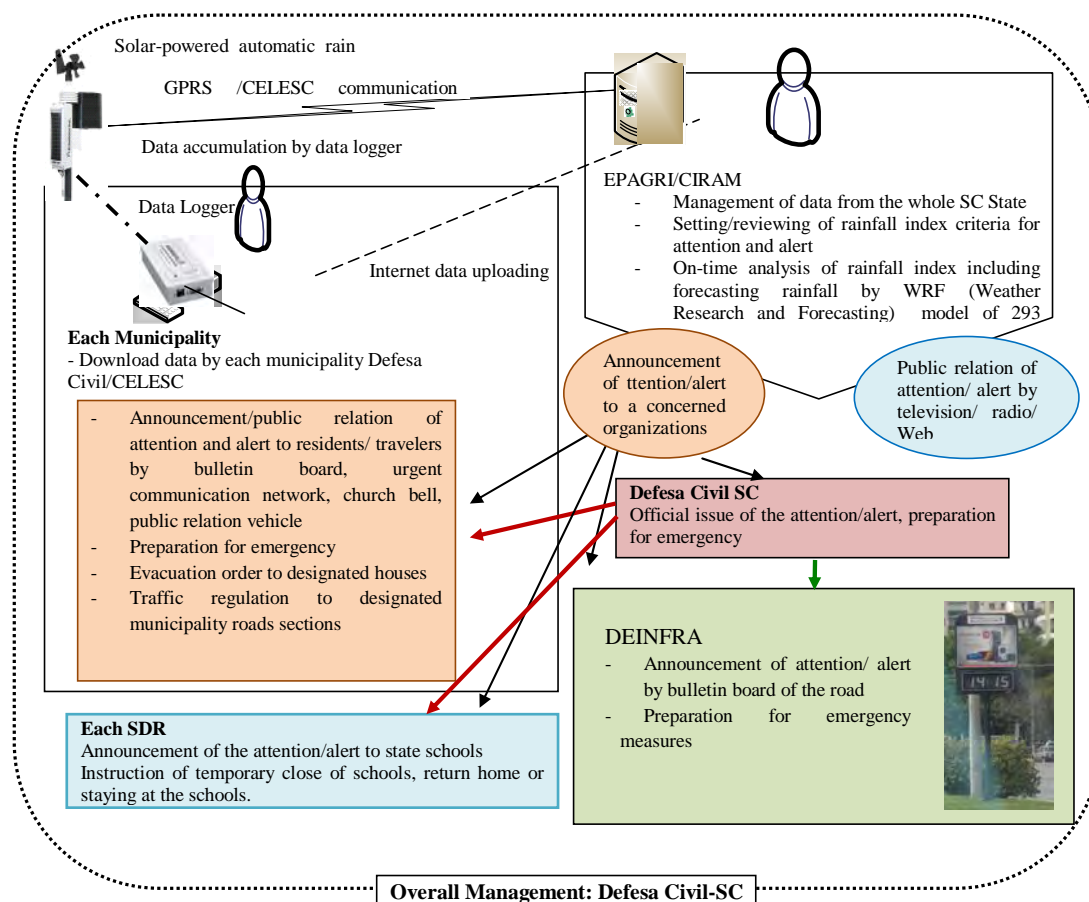

Source: JICA Survey Team

**Figure 14 Schematic Diagram for Early Warning Systems for Landslides and Flash Floods**

First, the early warning (information calling for attention) by rainfall index will be set as the kick off to increase the awareness of people in case of possible disaster, secondary designation of houses for evacuation and roads for traffic regulation corresponding to warning.

An alarm index is decided based on heavy rain of 10-year return period, since in Japan, 93% of landslide disasters occur under the conditions of maximum rainfall index at 10-year return period (based on 1991–2000 disaster occurrence excluding rock falls and disasters at construction sites). While an attention index is decided based on heavy rain at 1.1-year return period for the purpose of preparing for a state of alarm, recognition for residents and training of staff. The index criteria for attention/alarm should be verified and revised by EPAGRI/CIRAM every June (minimum rainfall month), based on accumulated rainfall and disaster occurrence data.

### 9.3 Structural Measures for Landslide

Structural measures will be conducted at priority sites which have higher potential annual loss in order to prevent economic loss due to landslide disasters.

Sixty-seven out of 68 high risk sites, excluding Itajaí Port, were selected as priority structural measure sites where continuous dredging might be appropriate. They are selected through landslide/sediment yield risk assessment and evaluated with more than R\$50,000 per year of potential annual loss. The risk sites selected include 33 state roads and 34 municipality roads. Structural measures against landslide are planned to secure half width road traffic against heavy rain levels of 60-year return period.

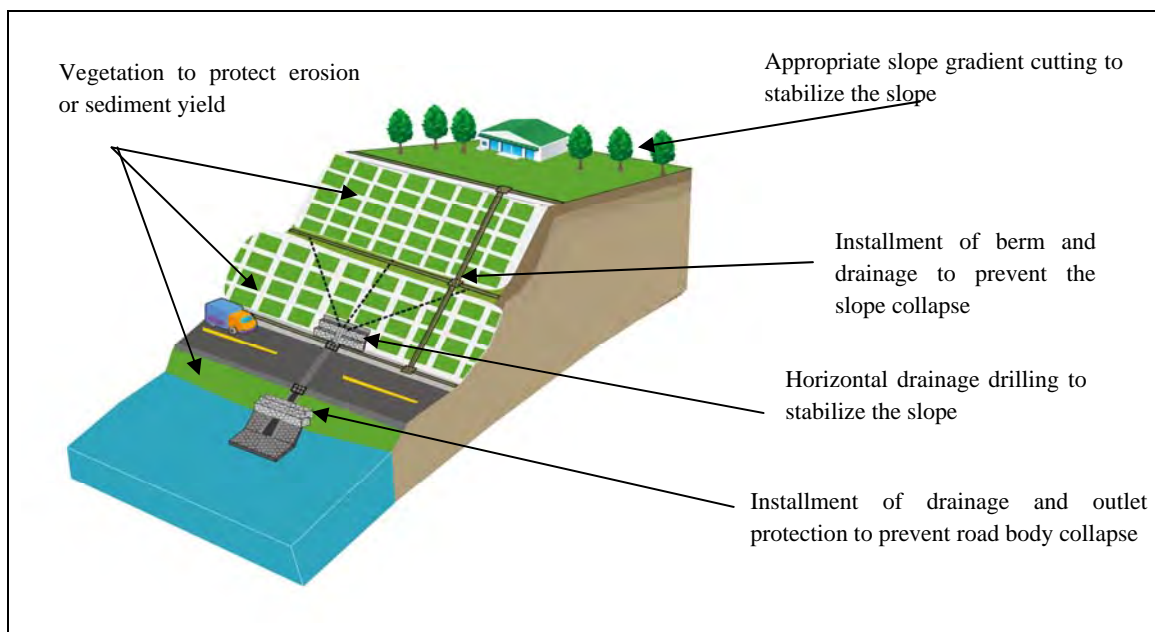

Figure 15 Example of Structural Measures against Landslide

#### 9.4 Mitigation Measures for Sediment Yield

Mitigation measures for sediment yield are promoted as reforestation projects which mainly aim at watershed and forest conservation and carbon fixation through tree planting. The mitigation measures of sediment yield are also applied at the structural measure sites for landslides. The main purpose of the measures is watershed and forest conservation.

In the Itajaí River basin, Itajaí Port is the only site with remarkable economic loss caused by riverbed aggradation. The annual amount of the potential loss due to sedimentation is R\$9 million per year and R\$19 per m<sup>3</sup> of sediments.

The mitigation measures of sediment yield in the whole basin by the reforestation of barren collapsed land and prevention of riverbank erosion by riparian forest should be promoted. The priority areas for mitigation of sediment yield is the Luiz Alves River where there is no significant sand extraction business, especially the Morro do Bau surrounding area where there are still many remaining collapsed bare lands and debris along streams after the storm in November 2008 .

The volume of sedimentation and the dredging volume in the Itajaí Port have not been monitored so far. After the monitoring of the sedimentation volume and clarification of the deposition mechanism, it would be desirable to adopt measures for sedimentation including sediments in the marine environment.

#### 9.5 Mitigation of Flash Flood

Measures for the reduction of flash floods aim to promote runoff regulation facilities for the purpose of reducing surface runoff. Flash floods become more serious due to the reduction of rainwater permeability by deforestation with land development in mountainous areas. Furthermore, it is recognized that are many housing areas along streams where there is no water in normal time. Such issues will be treated in the city plan.

#### 9.6 Capacity Building for Structural Measures and Support for Private Independent Efforts

Table 16 shows required the techniques and measures for reducing disasters and sediment yield.

**Table 16 Necessary Techniques and Plans to Mitigate Disasters such as Landslide/Flash Flood and Sediment Yield**

Technical Issues	Purpose and Objective	Recent condition	Measure
Installation of runoff regulation facilities for land development	To mitigate flash floods and floods caused by surface runoff increase due to land development	No technical standards	- Formulation of technical standards - Preparation of law to enable legal binding for new land development
Slope protection and slope stabilization	To stabilize slopes and protect slopes from erosion	Technical standards and methods for design review are available. The cases of instability of slopes and sedimentation are recognized. Drain ditches are not installed in some cases.	- Enhancement of design review to be conducted by the state and municipality. - Training of design and construction engineers by the state government.
Disposal of soil waste	To protect sediment yield	FATMA conducts legal instruction and management.	- Continuation of instructions and enforcement of laws and regulations

Source: JICA Survey Team

In addition, the promotion of disaster education for simple countermeasures such as drain ditches and support of official/private funds are recommended.

## 10. Initial Environmental Examination (IEE)

In order to clarify the conceivable environmental and social impacts caused by the project, scoping and IEE were carried out for all of the selected measures (alternatives). For scoping, 33 major environmental and social elements were identified based on the JICA Guidelines for Environmental and Social Considerations and Brazilian environmental impact assessment (EIA) study. For each alternative, qualitative evaluation was made by means of literature survey.

## 11. Total Project Cost, Economic Evaluation and Implementation Plan

The total cost of the master plan is as follows:

**Table 17 Cost of the Master Plan**

Safety Level of Flood Control	(R\$×10 <sup>3</sup> )			
	5 years	10 years	25 years	50 years
Flood Disaster Mitigation Measure	202,000	541,000	1,025,000	1,996,000
Landslide Disaster Mitigation Measure	54,000			
Flood Forecasting and Warning System (FFWS)	4,000			
Early Warning System for Flash Flood and Landslide Disaster	4,000			
Total	264,000	603,000	1,087,000	2,058,000

Source: JICA Survey Team

The cost of the measure was estimated based on the prices as of October 2010, in accordance with the following exchange rate: R\$1.0 = JPY 47.87 = US\$0.58. The unit cost of each work was estimated on the basis of the unit cost applied at the DEINFRA.

The evaluations will be carried out as a total program of the disaster mitigation measures, including FFWS and early warning system for flashflood and landslide disasters. The estimated project benefit values for each flood safety level was calculated by using a statistical method, on the basis of the registered disaster damages value published by the state government. The estimated annual damage reduction benefit was considered by multiplying the probabilities of each inundation and the damages caused by each flood safety level. The values used as bases of damages estimation for each flood safety level were the flood damages registered on October 2001 and November 2008. The results of economic evaluations are summarized in Table 18 below.

**Table 18 Results of the Economic Evaluation**

Evaluation Index		5 years	10 years	25 years	50 years
Economic IRR		38.2%	26.1%	19.9%	12.7%
Discount Rate 6%	B/C	5.05	3.26	2.64	1.75
	ENPV(R\$10 <sup>6</sup> )	825.4	1,053.3	1,317.4	1,090.8
Discount Rate 10%	B/C	3.69	2.38	1.89	1.24
	ENPV(R\$10 <sup>6</sup> )	425.8	500.1	550.0	257.9
Discount Rate 12%	B/C	3.21	2.07	1.63	1.06
	ENPV R\$10 <sup>6</sup> )	319.6	354.6	353.1	54.8

Note: IRR – Internal rate of return  
B/C – Benefits to costs ratio  
ENPV – Expanded net present value  
Source: JICA Survey Team

The discount rate applied for the economic evaluation considered the rate of tax of interest in the long term. The discount rate of 6% is the value used when the economy of Brazil is stable. The discount rate of 10%, on the other hand, is the value used when the economy of Brazil is in a situation of high interest rate. The results of the economic evaluation without tax and compensation show positive indicators in all of the aspects. These results indicate high economic viability for the implementation of the interventions presented in this report.

Figure 16 shows the implementation plan of the flood mitigation project for a 50-year flood safety level.

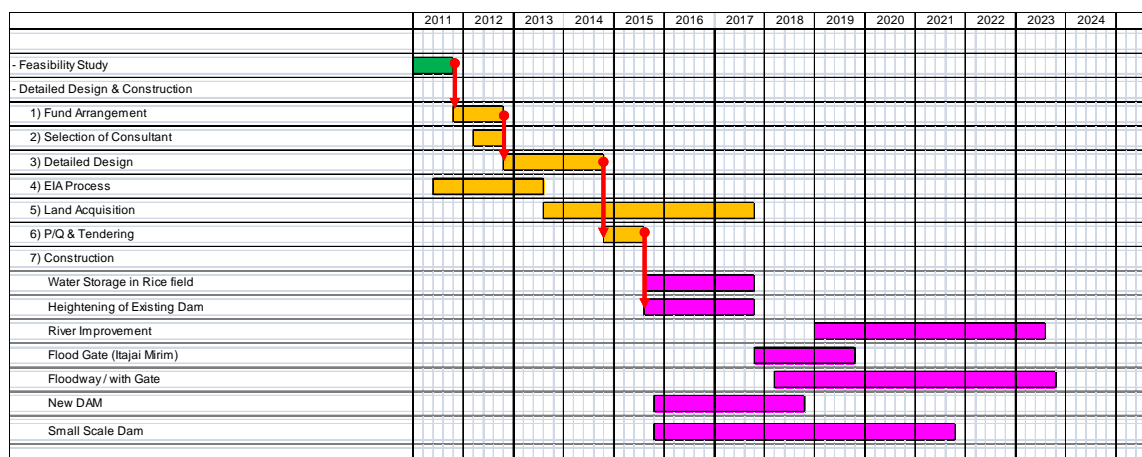

Source: JICA Survey Team

**Figure 16 Implementation Plan of Flood Mitigation Project for 50-year Flood Safety Level**

Figure 17 shows the implementation plan of structural measures for landslide management.

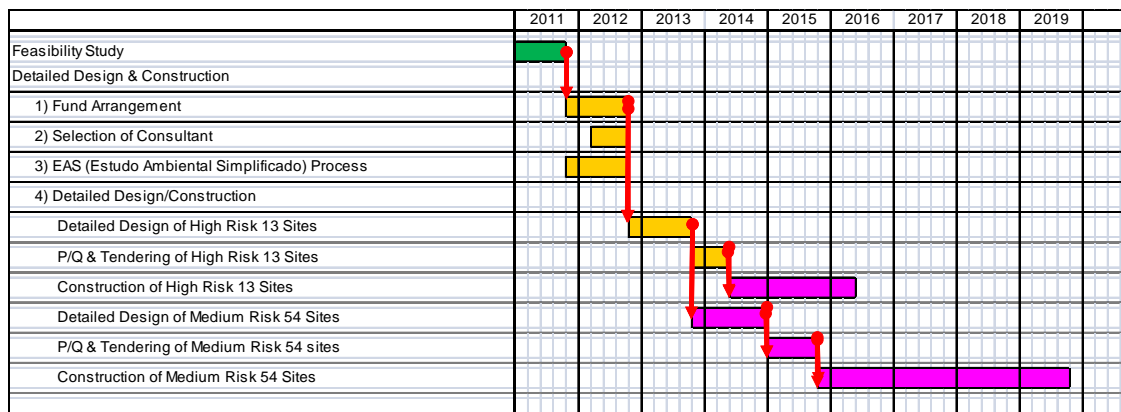

Source: JICA Survey Team

**Figure 17 Implementation Plan of Structural Measures for Landslide Management**

## 12. Recommendation for the Master Plan

### 12.1 Recommendations on the Master Plan for Flood Mitigation

The level of safety for flood (level of flood protection), which serves as a goal for the formulation of flood mitigation master plan, is usually represented by the probability of occurrence of flood or its recurrence interval. The flood safety level is determined politically, taking into consideration the size of the river basin, importance and development potential in view of the national and regional economic activities, basin population, land use, distribution of assets, etc. As much as possible, from the long-term perspective of civilian stability, the highest level of flood protection is desirable, although it takes huge investments and a long time to be realized.

In Brazil, a flood safety level has not yet been established based on the importance of the river. However, it is a basic policy to put water resources management including flood control into practice as included in the Federal Law No. 9433/08/01/1997. In this Preparatory Survey, the respective flood mitigation master plans were formulated for the 5-year, 10-year, 25-year and 50-year floods. For the future, the most desirable flood safety level for flood mitigation in the Itajaí River basin would be determined by the state government through discussions with the Itajaí River Basin Committee. The overall recommendations for the master plan are shown below.

- iii) In the water resources management master plan in the Itajaí River basin that was formulated by the Itajaí River Basin Committee in March of 2010, the development of basin storage (small dams) in the micro river basin and rain water storage in the paddy fields were proposed to be integrated as measures for flood mitigation and drought. The development of small dams focuses on small water storage, e.g., ponds to correspond to the shortage of irrigation water during the dry season. If many water storages were built in the micro basins, then they are considered to be promising from the aspect of hindering the concentration of flood runoff from micro basins like rain water storage in the paddy fields. The development of small dams was proposed in the master plan for the respective flood safety levels as one of flood control components. It is recommendable to implement small dams with priority.
- iv) The Itajaí River Basin Committee intends to build many very small ponds throughout the basin. Due to the limited time for the Study, small dams were selected directly on small streams based on the available topographical maps on a scale of 1:50,000 m with contour intervals of 20 m. These very small ponds to be built in cultivated lands and pastures could be proposed as alternatives to the small dams that were proposed in the master plan. However, in case of the safety level for the 5-year flood, the total reservoir capacity required for small dams is around 8 million m<sup>3</sup>. If a small pond is assumed to be of 100 m<sup>2</sup> in a 1 m of depth (10,000 m<sup>3</sup> in capacity), a total of 800 small ponds would be necessary. In case of the 10-year and 25-year flood protection, it would be necessary to build 2,800 and 4,100 small ponds, respectively. Considering that the construction of a small pond requires huge volume of excavation, the construction of small dams on small tributary rivers is more realistic.
- v) Heightening of the Oeste and Sul Dams becomes necessary at the safety levels for the 25- and 50-year floods, respectively. For smaller probable floods, both dams are able to control the floods safely with full closure of gates. However, this gate operation increases the risk of overflowing of the spillway. So, heightening of the dams becomes necessary to reduce the risk of overflowing.

- vi) It is necessary to obtain flood inflow into the reservoir every hour for proper dam operation. In general, dam inflow is calculated based on the change of reservoir capacity (changes of reservoir water level) and released volume of water from the dam. Therefore, the administrator of the dam should prepare H-V curve (relationship between the reservoir water level and reservoir capacity) and H-Q curve (relationship between the releasing discharge and gate opening in conjunction with reservoir water level). According to DEINFRA and Celesc, which act as the dam administrator, no H-V and H-Q curves are available. Besides, no as-built drawings (completion drawings) and completion documents of the existing dams have been left so far. A precise H-V curve can be created after the completion of the ongoing topographic mapping with a scale of 1:10,000. As for the H-Q curve, it can be created based on the hydraulic calculation. In view of adequate management and operation of dams, it is necessary to develop the updated basic information as enumerated above.
- vii) In formulating the master plan, the “flood control measures to scatter floods” was established by means of an active use of the allowable lands for flooding, since the lands that are subjected to frequent flooding such as pasture, paddy and dry fields are expected to hinder the concentration of flood runoff due to natural retarding effects thereof. Therefore, it is to be noted that the design flood discharges applied in the master plan did not include an increase of flood discharges to the downstream reaches due to future developments which are most likely to reduce retarding effects (land development, residential development, etc.).
- viii) Particularly, the design flood discharge of Itajaí mainstream in Itajaí City was estimated assuming the natural retarding effect of the existing flood plain spreading from Gaspar City to Itajaí City, where the Itajaí Valley drains to the alluvial plain which is preserved, i.e., without land developments. Future land developments in the flood plain should be regulated as much as possible so as not to reduce the natural retarding effect. However, when developed, runoff control measures such as retention pond shall be obliged to undergo land development, or additional water storages in the upstream basin shall be provided to compensate for an increase of flood discharge in the downstream reaches. The state government shall be responsible for the coordination and arrangement of such measures over the administrative areas of the municipal governments.
- ix) Absence of a river administrator was pointed out as a problem of the existing FFWS. Although the Itajaí River Basin Committee is responsible for formulating the master plan for water resources management, it might be impossible that the committee becomes an entity for river management. A government institution should be in charge of river administration considering that political decision is required for the planning and implementation of flood control works. The Water Resources Department of SDS shall be recommended for river management, since this department is in charge of water resources management (at present mainly for water utilization) and hydro-meteorological information system.
- x) In relation to the abovementioned statements, it is very important for proper river planning and management to obtain river channel conditions together with the information on rainfall, river runoff and river water level. As the river runoff is determined from the river water level, the H-Q curve (relationship between river water level and river runoff) shall be developed. The H-Q curve is developed based on the river section and the measurement of river runoff during the normal and flood conditions at the water level gauging station. It is recommended to annually update the H-Q curve



to improve its accuracy by discharge measurement for respective conditions. As sediment deposition in the river channel might influence the flow capacity, it is also recommended to carry out a river cross section survey periodically. In the survey, the reference point shall be established to monitor changes in the river channel. A survey interval of 3–5 years is desirable at each reference point and shall be carried out every year in an orderly manner. These basic data shall be stored in the database and must be available for use at all times. As for the rainfall and water level gauging stations, regular maintenance and update of the gauging equipment shall be scheduled.

## 12.2 Recommendations on Master Plan for Sediment Disaster Mitigation

The recommendations in the master plan for the sediment disaster mitigation are summarized below.

- i) The objective river basin of the master plan is the Itajaí River basin. However, the proposed early warning system for landslide/flash flood shall be introduced in the whole area of the State of Santa Catarina from the cost-effectiveness viewpoint of system development. Considering that there exist many different risks of occurrence of landslides and flash floods in all cities in the state, a rainfall gauge shall be installed in at least one location in each city.
- ii) The reference index for issuance of the early warning shall be based on the observed rainfall amount per unit time duration (for example, 30 minutes rainfall). The reference index expressed by a single rainfall value is much preferable compared to the combination of two rainfall index values (for example, combination of 90-hour rainfall and 48-hour rainfall). If a single value is introduced, it makes possible to evaluate accurately the risk level of the reference index in terms of the return period (recurrence interval). When the warning is issued, it is very important to announce the message in an easy and understandable way to be able to comprehend the impending sediment disaster such as “The highest risk of landslide and/or flash flood in these ten years is rapidly increasing.”
- iii) This early warning system is newly introduced. When the warning for landslide/flash flood is issued, the same dissemination and evacuation actions as the existing FFWS shall be applied. Human losses would be minimized if the municipal government identifies beforehand the risky locations and evacuation locations together with evacuation routes. If detailed hazard maps of sediment disasters are prepared like in Blumenau City, then these maps would be very useful as the basic data for efficient operation of the early warning system. Besides, the persons in charge of the communication and evacuation actions under the disaster situations have already been appointed in Ilhota City. These activities and programs shall also be applied to the other cities.
- iv) As for the disaster prevention measure for land development projects, enhancement of design review by the execution body (state government and municipal government) and training of engineers for design and construction management by the state government shall be required.
- v) Due to land developments, flood runoff is likely to increase because of an increase of surface runoff due to rainfall. In this respect, technical standards and government guidance shall be provided for the installation of a regulation pond for an increased flood runoff.

- vi) Structural measures for sediment disasters would also contribute to reduce sediment production. From the viewpoints of contribution to measures for climate change by means of carbon fixation, degraded bare slopes shall be vegetated and planting of trees without danger to be fallen shall be provided on the gentle and valley slopes of the road.
- vii) Effective measures against sediment production in the river basin are forestation of collapsed bare lands and provision of riparian forest to prevent riverbank erosion. The forestation shall be promoted as a multipurpose project with primary purposes of conservation of water resources, forest and environment. As proposed in the master plan of Water Resources Management in the Itajaí River basin, riparian forest recovery program and forestation program for the areas allotted for watershed conservation shall be promoted.
- viii) The Itajaí Port is the only location where economic loss has occurred due to a remarkable riverbed rising. However, no measurements so far has been carried out on sediment inflow into the port and dredged volume in the port. It is necessary to clarify the mechanism of sediment deposition in the port, reflecting sediment inflows from the sea by tide and Itajaí River. One idea is to solicit universities such as Universidade do Vale do Itajaí (UNIVALI) for hydraulic researches and experiments. A reasonable mitigation measure of sediment deposition in the Itajaí Port shall be formulated based on the clarified mechanism.

## Part II : Feasibility Study

### 13. Selection of Priority Projects for Feasibility Study

#### 13.1 Selection of Priority Projects

The JICA Preparatory Study Team submitted the Interim Report to the State Government of Santa Catarina on December 10, 2010 in accordance with the Scope of Works of the Preparatory Survey. The Interim Report described the Master Plan of Disaster Prevention in the Itajaí River basin that was formulated in the first phase of the Preparatory Survey, which was commenced on March 25, 2010 as the first field work in Brazil.

The state government decided to realize a master plan of the 50-year flood as the final goal of flood security level. In view of the required huge investment and long period for realization, the state government decided to implement the master plan as a stage-wise development, gradually increasing a flood security level as illustrated in Figure 18 below. The state government also decided to adopt a security level considering a 10-year flood level for the first stage of implementation.

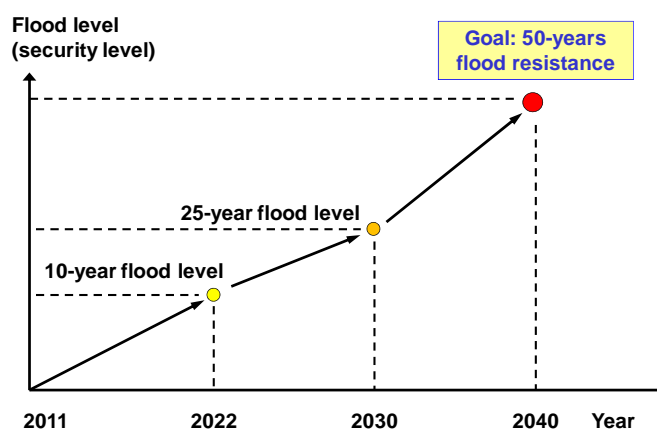

Source: JICA Survey Team

**Figure 18 Image of Stage-Wise Implementation of the Flood Mitigation Plan**

Along this line, the following priority projects that are subject to feasibility study in the second phase of the Preparatory Survey were finally selected by the state government for the first stage of implementation:

- i) Water storage in the paddy fields
- ii) Heightening of the existing flood control dam and change of gate operation method (two dams)
- iii) Utilization of the existing hydropower generation dam for flood control (two dams)
- iv) Strengthening of the existing FFWS
- v) Installation of two floodgates on the Itajaí Mirim River in Itajaí City

Together with the abovementioned priority projects, the following two projects were chosen for the first stage of implementation for the realization of sediment disaster prevention master plan:

- i) Slope protection of roads at 13 locations
- ii) Installation of early warning system for sediment disaster and flash flood

## 14. Feasibility Study on Water Storage in Paddy Fields

### 14.1 General Policy of Plan

This plan aims to enlarge the flood retention capacity, by using the expansion of the paddy fields in all subbasins with provision of heightened paddy ridge and gradually to introduce rice production with better quality and safety. In this regard, the measures will develop the following activities:

- |  |   |
|--|---|
| Increase of capacity of reduction of the effect of floods    | - Elevation of the paddy ridge.   |
| Use of land in accordance with the Environmental Legislation | - Recovery of the riprap forest.<br>- Incentive for the use of farm land in accordance with environmental legislation |
| Safety foods supply  | - Incentive to introduce integrated rice production   |

Due to the extension of paddy fields to the entire basin, and the fact that there are approximately 2,000 farmers, there is complexity in the implementation of this plan if it is contract-based. Besides, because of the characteristics of this plan, and having a lot of stages of processes during materialization, it is suggested that the execution is done in the following way:

Government	Producers
<ul style="list-style-type: none"> <li>- Lending of services and consultancies for the implementation of the plan</li> <li>- Incurring project cost (80%)</li> </ul>	<ul style="list-style-type: none"> <li>- Works of heightening of the ridge</li> <li>- Planting of nursery plants, and placement of the contentions of margins of the river</li> <li>- Incurring project cost (20%)</li> </ul>

It is foreseen to execute the heightening of the paddy ridge from the current 10 cm to more than 10 cm to 30 cm, hoping to increase the capacity of retention of rain from 2,000 m<sup>3</sup> to approximately 3,000 m<sup>3</sup> per hectare as shown in Figure 19 below.

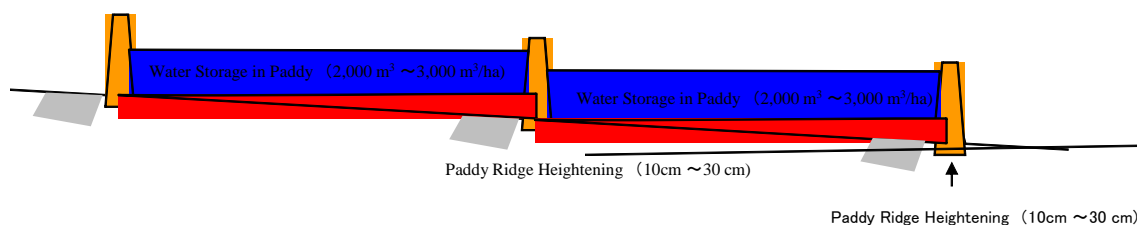

Source: JICA Survey Team

**Figure 19 Retention Method of Flood Water in Paddy Fields**

### 14.2 Organization of Project Implementation

The executive organization of this project is the State Secretariat of Civil Defense (SDC). For the implementation of this project, the SDC will acquire the machineries, equipment and consultancies. The acquired machineries will be administered by the CIDASC (Integrated Company of Agricultural Development of Santa Catarina) to lend to the producers. The necessary expenses for the implementation of works for the producers will be financed by the FDR (Fund of Rural Development). The CIDASC and the FDR are the institutions subsidizing the SAP (State Secretariat of Agriculture and Fishing). The CIDASC was created in the year 1979, to promote agribusiness and the sustainable development of Santa Catarina. The FDR has to pay for the financial expenses of SAP. At present, it is executing some projects financed by the World Bank.

## **15. Feasibility Study on Heightening of the Existing Flood Control Dams and Modification of Dam Operation**

### **15.1 Field Investigations**

The topographic survey was carried out at the two dams to confirm the structural dimensions of both dams, which were basically required for the feasibility level design for heightening. In addition, the geological survey was carried out to estimate the foundation profile of the dams. Drillings were carried out at three locations at the Oeste Dam and one location at the Sul Dam. Based on the results of the drilling survey and detailed site investigation, the unconfined compression strength of fresh bedrock is estimated at about 30 MN/m<sup>2</sup>, classified as medium strong rock at both dams. In the crack zone, the crack spacing is more than 5 cm. According to the existing result of the shearing test for similar rock, the shear strength is estimated as  $\tau = 1.0 + \sigma \tan 38^\circ$  (MN/m<sup>2</sup>) for both dams.

### **15.2 Feasibility Design for Civil Structures**

#### **(1) Oeste Dam**

It appeared by the topographic survey and hydraulic calculation of the design discharge that the non-overflow section of the dam body should be heightened by 2.01 m, although the spillway section is by 2.0 m. Figure 20 shows the designed sections. Stability analysis was carried out to confirm the stability against overturning due to heightening, dividing the non-overflow section into several sub-sections. It appeared that all of the sub-sections are sufficient for the required safety factor of 1.10, which is required for the structure against overturning. However, it appeared that the spillway section is insufficient for the required safety factor. The facing concrete at the downstream slope was thus proposed in the whole section of the spillway. The downstream slope is set at 1:0.78.

No energy dissipater is provided at the Oeste Dam. The energy dissipater is generally installed at the outlet of the spillway to dissipate large energy of the overflowed water of the spillway. Heightening of the spillway might cause larger energy since the overflow head becomes higher. Taking into account the hydraulic aspect, installing the dissipater was proposed. The proposed dissipater is the submerged bucket type considering that the river water level immediately downstream of the dam is always high as illustrated in Figure 21.

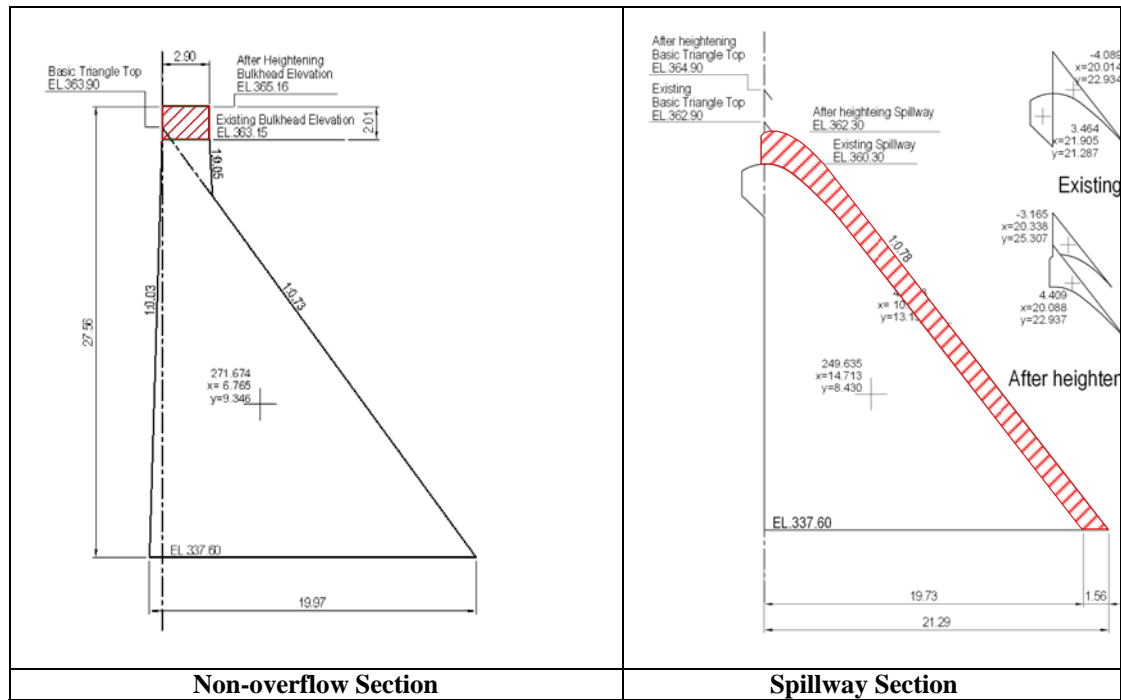

Source : JICA Survey Team

Figure 20 Designed Sections of the Oeste Dam

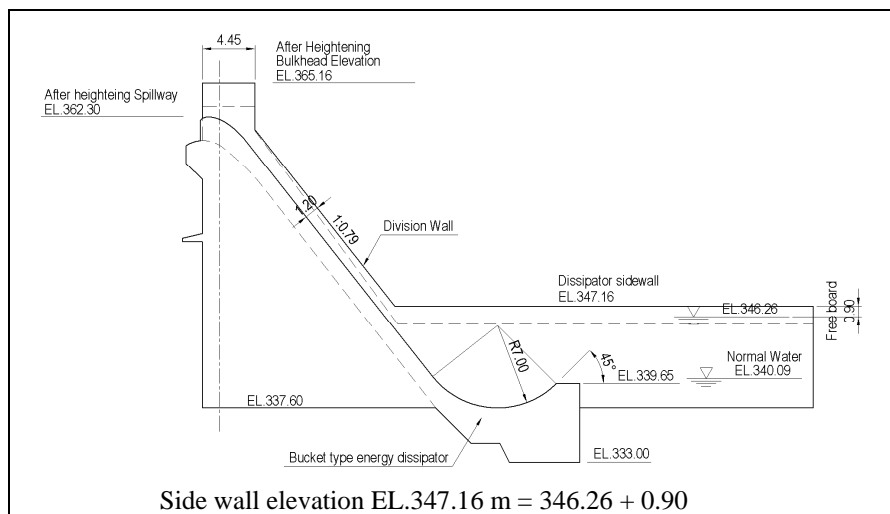

Source : JICA Survey Team

Figure 21 Proposed Energy Dissipater at the Oeste Dam

(2) Sul Dam

The Sul Dam is proposed to be heightened only on the spillway section by 2.0 m because of sufficient freeboard to the dam crest after heightening as illustrated in Figure 22. As shown, the maximum overflow depth of the design discharge of 2,570 m<sup>3</sup>/s (= 10,000-year flood) is 7.0 m under the present spillway. However, even though the spillway is heightened by 2.0 m, there would still be more than 1.0 m space allotted for the freeboard.

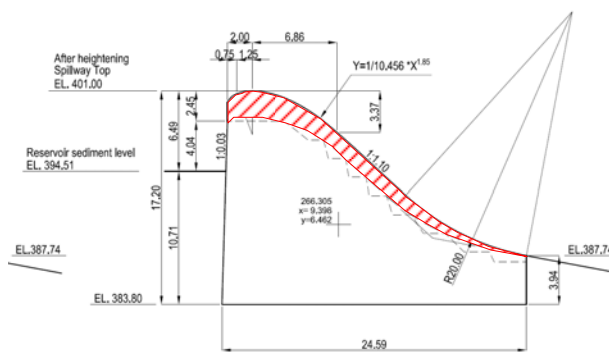

Source : JICA Survey Team

**Figure 22 Comparison of Overflow Depth of Design Discharge on the Spillway of Sul Dam**

### 15.3 Field Investigation on Existing Conduit Gates

Since the conduit gates of both Oeste and Sul Dams were constructed more than 40 years ago, it is a concern that the strength of the conduit gates has been weakened due to long-term corrosion. Field investigation was carried out at both dams. It was found that no corrosion is observed and the conduit is still in good condition. The result upon measuring the plate thickness and gates revealed that the values of corrosion are estimated to be 0.1–0.2 mm. Therefore, the estimated loss due to corrosion is just a very small value.

The standard of ABNT NBR 8883:2008 in Brazil for the gate design was applied. Therefore, the strength of the existing gates and conduit pipe were analyzed using the said standard. Even if the water level is raised by 2.0 m, the existing gates still have enough strength judging from the calculations. This is mainly due to the fact that the corrosion speed is slow and the thickness of the margin (which was designed against long-term corrosion, and it is supposed to be about 1.0 m) still remained even 40 years has already passed. Thus, it is proposed that the existing facilities be maintained as these still satisfy the strength requirements even after the dam heightening.

### 15.4 Modification of the Operation

Figure 23 shows the proposed flood control operation at the Oeste Dam. If all the gates are fully opened during the 10-year flood, maximum flood discharge in Taio City is estimated at 520 m<sup>3</sup>/s. This discharge exceeds the current flow capacity of 440 m<sup>3</sup>/s in Taio City. Therefore, the required peak cut for the 10-year flood at the Oeste Dam is estimated at 80 m<sup>3</sup>/s. It is desirable to close fully all the gates during the flood as long as possible, expecting the effects of flood control in Rio do Sul City and simplification of the operation.

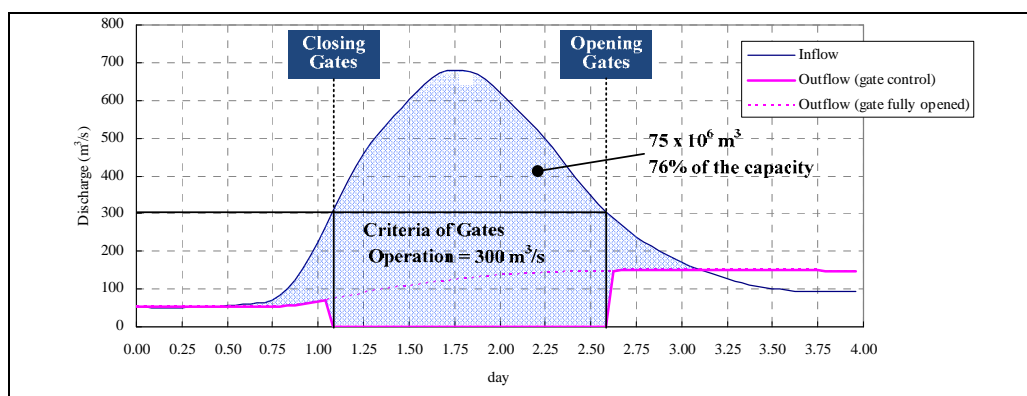

Source: JICA Survey Team

**Figure 23 Method of Flood Control at the Oeste Dam**



Figure 24 shows the proposed flood control operation at the Sul Dam. If all the gates are fully opened during the 10-year flood, maximum flood discharge in Rio do Sul City in the Itajaí do Sul River is estimated at 570 m<sup>3</sup>/s. This discharge exceeds the current flow capacity of 440 m<sup>3</sup>/s in Rio do Sul City. Therefore, the required peak cut for the 10-year flood at the Sul Dam is estimated at 130 m<sup>3</sup>/s.

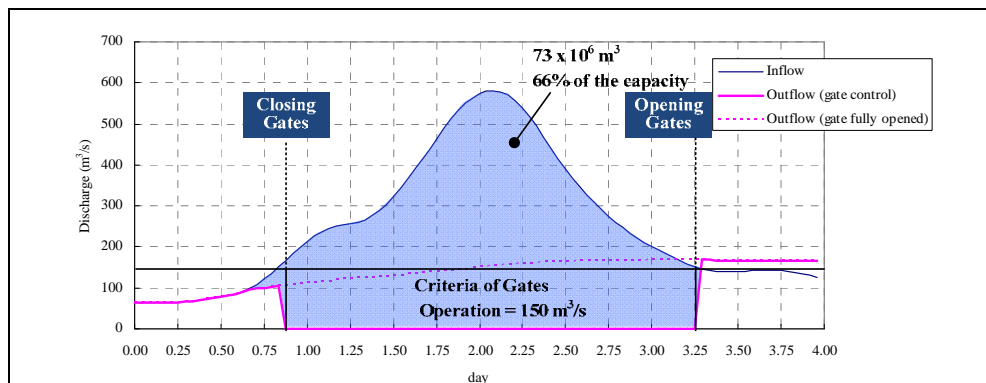

Source: JICA Survey Team

**Figure 24 Method of Flood Control at Sul Dam**

### 15.5 Increasing of Discharge Capacity in Sul and Oeste Dams

A huge flood attacked the Itajaí River basin from 6th to 9th in September 2011, after the Feasibility Study carried out from February to July. As some problems such as insufficient discharge capacity of the outlets in Sul and Oeste Dams were revealed during the flood, the study team proposed increasing of the discharge capacities in these dams, at the time when study team submitted the draft final reports in September, by installing a new conduit in the new dam body on left bank of Oeste Dam, and a new tunnel type conduit under the ground in right bank of Sul dam with tunnel type.

## 16. Feasibility Study on the Modification of Operation of Existing Hydropower Dams

### 16.1 Background of Modification

In the master plan, the existing two hydropower generation dams of Celesc in the Rio dos Cedros River, named the Rio Bonito and Pinhal Dams, were proposed to be used for flood control by means of pre-releasing when an impending flood is predicted. The proposed pre-releasing aims to create flood control space in the reservoir by means of lowering the reservoir water level by releasing the stored water before flood inflow into the reservoir.

The target city of pre-releasing is Timbo City, where the Rio dos Cedros City joins the Benedito River. The current flow capacity of Benedito River in Timbo City is estimated at 860 m<sup>3</sup>/s, although the 10-year flood discharge is around 920 m<sup>3</sup>/s. Therefore, the flow capacity is insufficient for the 10-year flood. On the other hand, the 10-year flood inflow into both of the dams is 210 m<sup>3</sup>/s. The total outflow from both dams should be jointly controlled in order not to exceed 140 m<sup>3</sup>/s yet still satisfying the current flow capacity in Timbo City by using the created flood control space in the reservoir through pre-releasing.

### 16.2 Study on Pre-releasing

In order to regulate the outflow discharge from both dams not exceeding 140 m<sup>3</sup>/s for the 10-year flood with a peak discharge of 210 m<sup>3</sup>/s, the required flood control volume to be created by means of pre-releasing was examined through simulation of reservoir operation at both dams. The results of the examination are summarized in Table 19. As indicated in this table, the required volume for pre-releasing was estimated to be 1.4 million m<sup>3</sup> for the Rio Bonito Dam and 3.2 million m<sup>3</sup> for the Pinhal Dam, respectively.

**Table 19 Required Flood Control Volume to be Created by Pre-releasing at Two Dams**

	<b>Rio Bonito Dam</b>	<b>Pinhal Dam</b>
Maximum water level in operation	EL. 589.5 m	EL. 652.0 m
Drawing down by pre-releasing	0.5 m	1.0 m
Water level after pre-releasing	EL. 589.0 m	EL. 651.0 m
Volume for flood control by pre-releasing	1.4 x 10 <sup>6</sup> m <sup>3</sup>	3.2 x 10 <sup>6</sup> m <sup>3</sup>
Maximum inflow discharge	85 m <sup>3</sup> /s	125 m <sup>3</sup> /s
Maximum outflow discharge	60 m <sup>3</sup> /s	85 m <sup>3</sup> /s
Reduction of discharge at the peak time of inflow	25 m <sup>3</sup> /s	45 m <sup>3</sup> /s
Operation of gates during flood control	Constant opening	Constant opening
Gate opening of the spillway	0.5 m	1.0 m
Gate opening of the intake	2.6 m	2.6 m
Operation of gates before flood control	Keep the water level at EL. 589 m (inflow = outflow) by operating intake gate	Keep the water level at EL. 651 m (inflow = outflow) by operating intake gate
Operation of gates after flood control	Keep the water level at EL. 589.5 m (inflow = outflow) by operating spillway gate	Keep the water level at EL. 652 m (inflow = outflow) by operating spillway gate

Source: JICA Survey Team

As the pre-releasing increases the flow in the downstream reaches, the operators at the dams and the river administrator should pay attention to the security of riparian residents along the downstream reaches as follows:

- i) For preventing overflowing from the river channel by pre-releasing, river water level along the downstream reaches should be monitored in the cities of Timbo and Rio dos Cedros.
- ii) Warning of pre-releasing should be announced to the residents along the downstream reaches by sirens before the pre-releasing.

For rainfall forecast, CIRAM currently uses both the ETA model of INPE and WRF model of USA for the coming five days. At present, Defesa Civil, EPAGRI, and SDS intend to establish a new rainfall and flood forecasting system with satellite data from INPE. Accuracy of the flood forecast is expected to be improved by the new system.

### 16.3 Recommendation of Organization for Operation

Figure 25 presents the recommendation of the organization for executing the pre-releasing in the existing hydropower dams.

- i) As the river administrator shall be responsible for the judgment and operation of the pre-releasing, the same administrator also instructs the execution of pre-releasing to Celesc based on the flood forecast by CIRAM and monitored water levels along the Rio dos Cedros River.
- ii) Celesc should inform the pre-releasing to the municipal governments (Timbo and Rio dos Cedros Cities) in advance and municipal governments should alarm the residents along the river.
- iii) If any flood flowed into the catchment area of both dams during the pre-releasing's execution, the lowered water levels of the dam reservoirs might not be restored. The state organization responsible for flood management and Celesc should discuss and decide the regulation of such compensations.

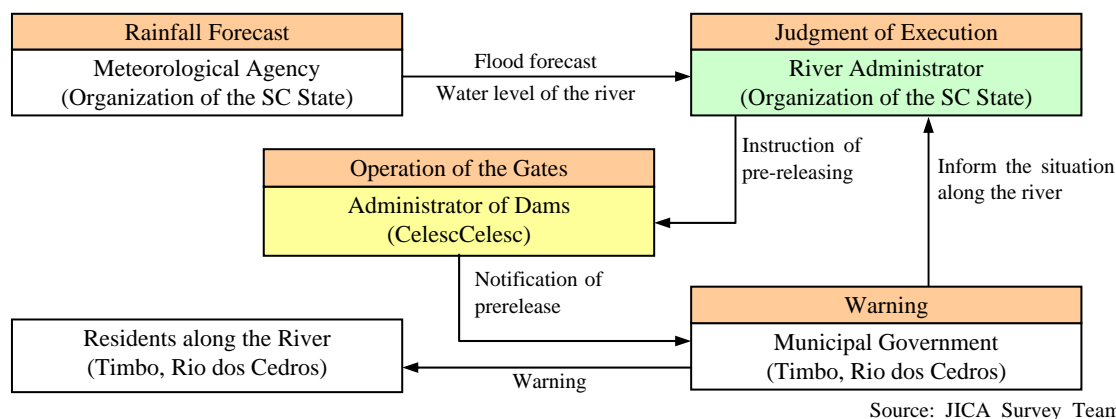

Figure 25 Recommendation of Organization for Dam Operation

## 17. Feasibility Study on Floodgates in the Itajaí Mirim River

### 17.1 Topographical Characteristics of Itajaí Mirim River

The riparian area along the Old Mirim is generally low with varying elevations of 1.0 to 3.0 m. On the other hand, the area along the canal is relatively higher with elevations around 3.0 to 4.0 m. Although the canal has a larger flow capacity, the Old Mirim has caused frequent flooding and inundation to its riparian area. Two floodgates on the Old Mirim which were proposed in the master plan aim to mitigate inundation along the Old Mirim.

There are mainly three causes of the inundation in Itajaí City along the Old Mirim, namely: 1) the flood from the upstream basin area of the Itajaí Mirim River, 2) the backwater from the Itajaí River, and 3) the inland water due to rainfall over this area.

### 17.2 Function, Operation and Effectiveness of Floodgates

Floodgates were proposed to be installed at two locations on the Old Mirim as shown in Figure 26 below. The gates of the upstream and downstream locations are herein called the “downstream gate” and “upstream gate”, respectively. The upstream gate would prevent the flood from the Itajaí Mirim River from entering the urban area while the downstream gate would avoid the intrusion of backwater from the Itajaí River.

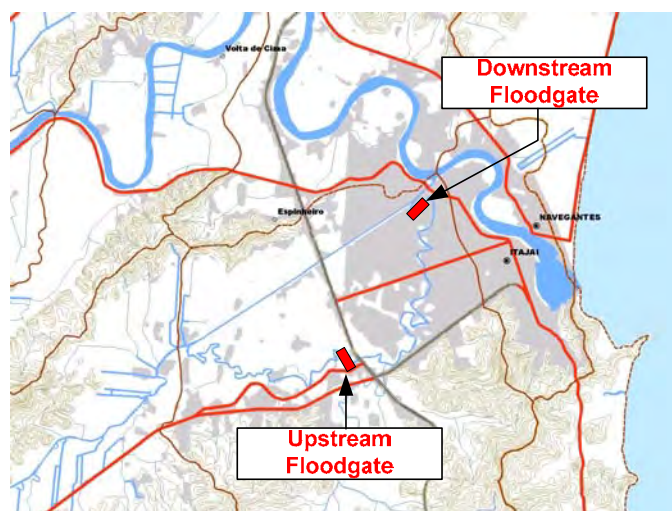

Source: JICA Survey Team

Figure 26 Location Map of Floodgates in Old Mirim

The upstream gate would be closed when the discharge from the Itajaí Mirim reaches the flow capacity of the Old Mirim. In this regard, the operation needs the information on the water level of the Old Mirim in the urban area (in the downstream area of the BR-101).

On the other hand, the downstream gate would be closed when the water level at the downstream end of the Old Mirim reaches the critical water level. Therefore, the operation of the downstream gate also needs the information on the water level at the downstream end of the Old Mirim.

The Civil Defense of the municipal government in Itajaí City has already installed nine gauging stations (with nine water level gauges and eight rainfall gauges) in February 2011. The location map is shown in Figure 28. Both gauges “DO-06” and “DO-04” will be used for the operation of both floodgates.

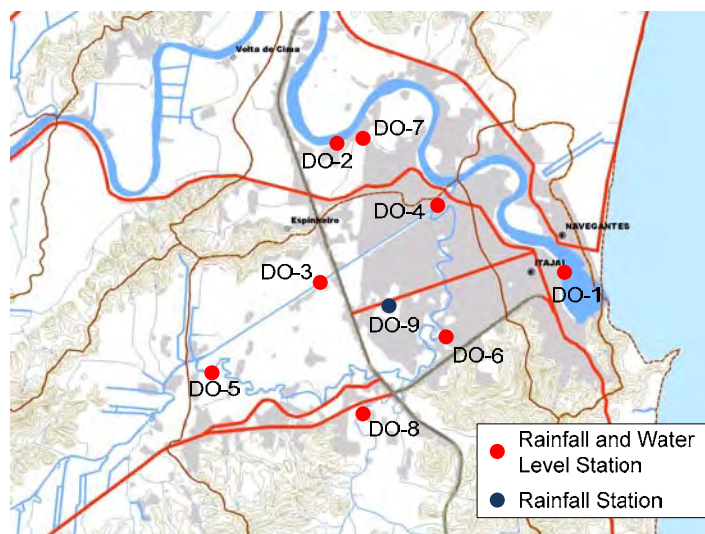

Source: JICA Survey Team

**Figure 27 Location of Water Level and Rainfall Gauges Installed by Itajaí City**

The inundation area and depth in the downstream area of BR-101 along the Old Mirim with and without the floodgates are illustrated in Figure 28. The effectiveness of the floodgates is evaluated as shown in Table 20.

**Table 20 Estimated Inundation Area Along the Lower Old Mirim**

Inundation Depth (m)	Area (m <sup>2</sup> ) without gate control	Area (m <sup>2</sup> ) with gate control	Effectiveness (m <sup>2</sup> )
< 0.5	2,216,400	564,400	1,652,000
0.5 – 1.0	1,299,600	527,600	772,000
1.0 – 1.5	848,800	242,000	606,800
1.5 – 2.0	431,600	22,000	409,600
2.0 – 2.5	441,200	0	441,200
2.5 – 3.0	40,000	0	40,000
Total	5,277,600	1,356,000	3,921,600

Source: JICA Survey Team



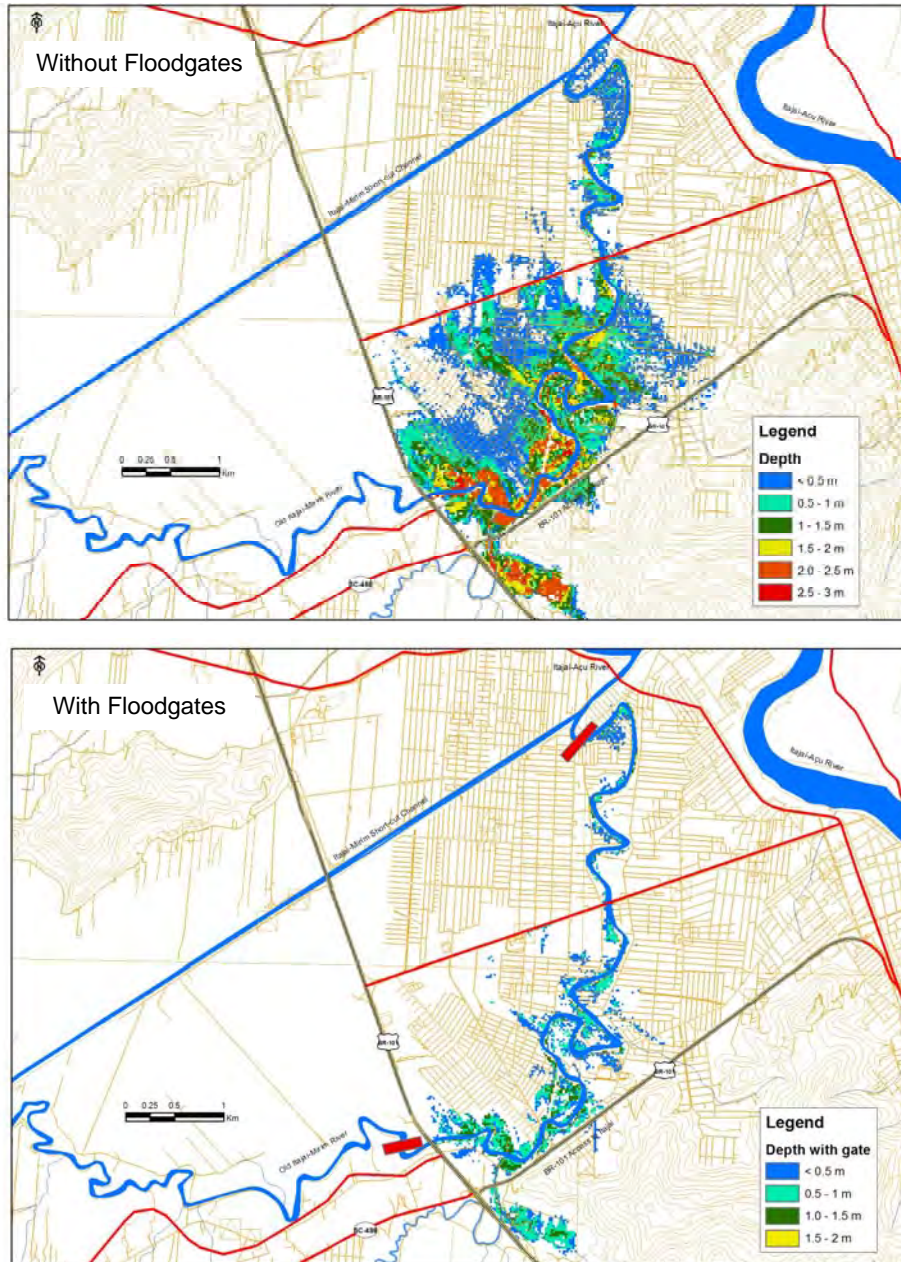

Source: JICA Survey Team

**Figure 28 Estimated Inundation Area Along Old Mirim With and Without Floodgates**

The operation of floodgates needs hydrological information only around Itajaí City since it only affects the area around the city. The operation shall be executed by the municipal government of Itajaí City. The flood management department of the state government should be responsible for the implementation of the project (construction of the floodgates), study and instruction of the gates operation method, supervision of the actual operation by Itajaí City during flood time, preparing the maintenance plan, and obtaining the budget for maintenance.

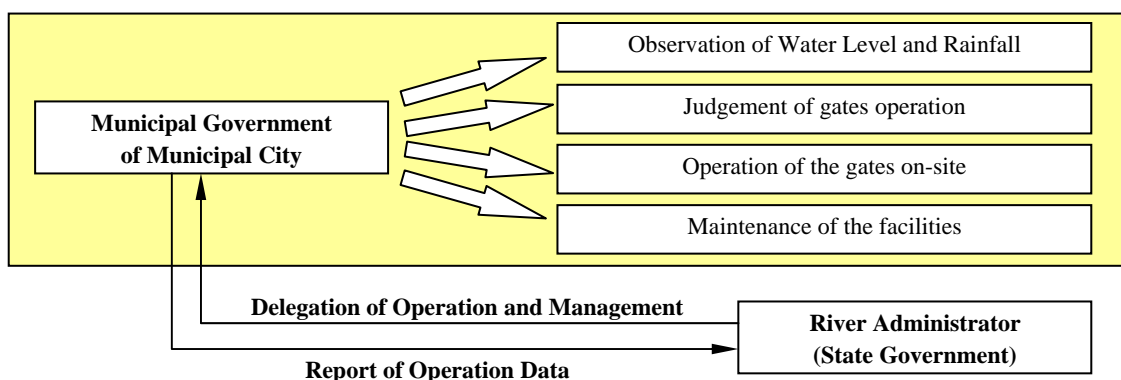

Source: JICA Survey Team

**Figure 29 Recommendation of Organization for Operation**

### 17.3 Feasibility Design of Floodgates

The proposed sites of both floodgates are in the alluvial plain on the Old Mirim River. From the results of the drilling survey, the geology of both sites is alluvial deposit in the Quaternary System from the surface to more than 38 m of depth, although the depth of the bottom of the alluvial deposit is not confirmed. It appeared through the drilling survey that bearing layers were located under the riverbed 12 m deep at the downstream floodgate and 30 m deep at the upstream floodgate. Therefore, pile foundation was proposed for both floodgates.

The main features of the designed floodgates are summarized in Table 21 below. Figure 30 shows the general layout plan of the floodgates.

**Table 21 Main Features of Floodgates**

Gate	Downstream Gate	Upstream Gate
No. of Gates	3	3
Span of Gate	12.5 m	12.5 m
Foundation Elevation	EL. -5.0 m	EL. -4.3 m
Bottom Elevation of Gate	EL. -1.0 m	EL. -1.0 m
Main Structure	Separate slab and pier	Separate slab and pier
Gate Pier	EL. 7.70 m 6.00 m wide 14.20 m high	EL. 12.00 m 11.20 m wide 17.80 m high
Gate Operation System	On the top of pier	On the top of pier
Apron Length	6.0 m	8.0 m
Sheet Pile for Seepage	Downstream 2.0 m Upstream None	Downstream 2.5 m Upstream 5.5 m
Revetment	Downstream 10.0 m Upstream 10.0 m	Downstream 10.0 m Upstream none
Stair	Installed	Installed
Foundation	Pile foundation Pier :L=11.0 m $\phi$ 400 mm Slab :L=11.0 m $\phi$ 300 mm	Pile foundation Pier :L=27.0 m $\phi$ 400 mm Slab :L=27.0 m $\phi$ 300 mm

Source: JICA Survey Team

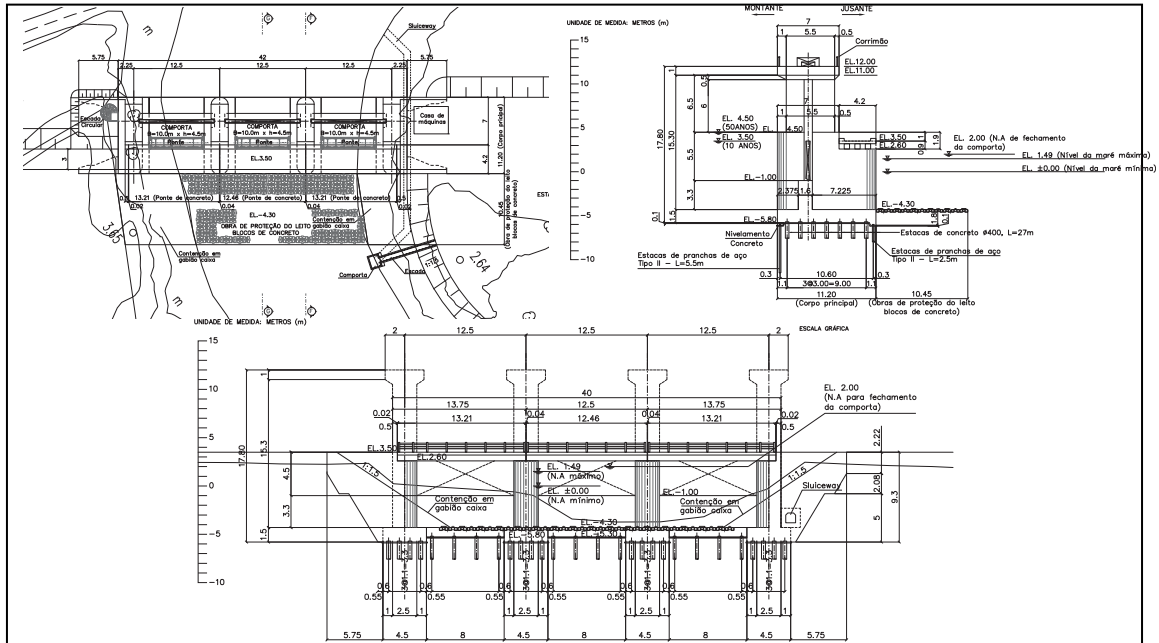

Source: JICA Survey Team

**Figure 30 General Layout Plan of Floodgate**

Around 1.0-km long river stretch along the Itajaí Mirim River between the confluence with the Itajaí River and the downstream floodgate is subjected to backwater effect of the Itajaí River. With the provision of a backwater dyke by means of sheet piles, no relocation of residences is required.

## 18. Feasibility Study on Strengthening of the Existing FFWS

### 18.1 Strengthening of the Existing Hydrological and Meteorological Observation System

As included in the master plan 13, new rainfall and water level gauging stations and three CCTVs were proposed in order to strengthen the existing FFWS. Moreover, three gauging stations and two CCTVs shall be added at the two flood control dams (Sul and Oeste Dams) and two hydropower dams (Rio Bonito Dam, Pinhal Dam) through the meeting with the concerned organizations (Defesa Civil, SDS and CEOPS/FURB) and the workshop held on April 29, 2011 regarding the FFWS and dam operation. The final monitoring network is illustrated in Figure 32.

### 18.2 Verification of the Existing Flood Forecasting Method

The existing FFWS has not been systematically conducted throughout the entire Itajaí River basin. More specifically, flood forecasting is conducted only at Blumenau (by FURB) and Rio do Sul (by municipal Defesa Civil, but still in trial stage). The current flood forecasting formula at Blumenau and Rio do Sul were verified, and the course of the flood forecasting method was studied for Itajaí City. As for the other cities, it is firstly important to maintain the current warning system based on the existing warning water level.

#### (1) Verification of the Existing Flood Forecasting Formula at Blumenau

Flood water level at Blumenau is forecasted based on a correlation method (ARIMAX Model Method) using water levels situated at Blumenau, Apiuna and Timbo. This correlation formula was developed by the FURB/CEOPS in the 1990s. The verification of this formula using flood data in April 2010 resulted in that the correlation formula still has sufficient accuracy for it to be



applicable to flood forecasting at Blumenau. The accuracy of the correlation formula should be evaluated and updated if necessary whenever there are occurrences of flood in the future.

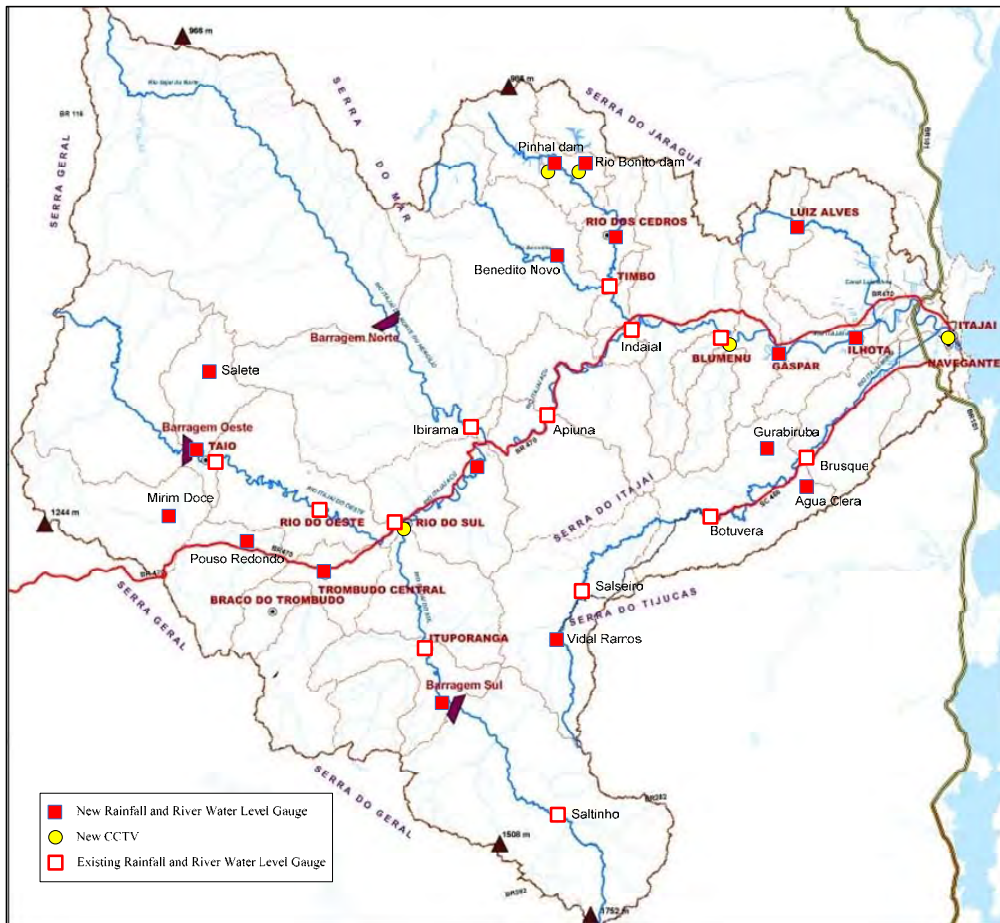

Source: JICA Survey Team

**Figure 31 Location Map for the Proposed Gauging Stations and CCTV**

(2) Verification of the Existing Flood Forecasting Formula at Rio do Sul

The current formula was developed by municipal Defesa Civil of Rio do Sul City. Since the forecasted flood water level by this formula is an expected daily mean water level, the formula is not applied to the present warning system.

- The general correlation methods should be firstly applied for hourly flood forecasting in the future.
- Since the water level in Rio do Sul is prone to be influenced by the operation of the existing upstream flood control dams, it might be needed to establish flood forecasting models using runoff analysis and effects of the dams instead of having a correlation model.
- In order to establish the model mentioned above, it is needed to set up regulations and systems in which the dam administrator (DEINFRA) must transmit dam operating data, such as outflow discharge and gate control, to the organizations responsible for flood forecasting (municipal and state Defesa Civil or SDS).

(3) Flood Forecasting System at Itajaí City

The warning system based on flood forecasting is also required for Itajaí City. However, flood water level at Itajaí City is rather difficult to forecast due to the tidal effects of sea water and flood flow from the Itajaí Mirim River.

The municipal Defesa Civil of Itajaí City newly installed eight water level gauging stations in the city on February 2011, which can later be of great use to the municipal warning and evacuation system. However, it is presently difficult to establish the flood forecasting system due to the lack of information from Blumenau and Brusque about the river water level.

Defesa Civil, SDS and EPAGRI of the state government intend to develop the flood forecasting model by means of the runoff and inundation analyses. Although it is important to develop such available model, it requires much time and sufficient database of meteorological and hydrological data to be provided from the existing and proposed gauging stations. Meanwhile, the flood warning and evacuation announcement should be carried out by the state government using the water levels in the upstream reaches.

- No past flood water level data is available at Itajaí City at all, but the past inundation record in Itajaí City should be researched with the corresponding flood water level data at Blumenau and Brusque in order to establish the flood forecasting method in Itajaí City.
- The flood forecasting method in Itajaí City should be developed through research about the following: i) relationship between the inundation level in Itajaí City and upstream flood water level, and ii) arrival time of flood, using future flood data at the existing and proposed gauging stations (Ilhota, Gaspar, Blumenau and Brusque).

### **18.3 Proposed Organization for the Strengthening of Existing FFWS**

It is required to establish not only the facilities and systems for the FFWS, but also the appropriate institutional organization and evacuation manual linked with the FFWS so that the FFWS works effectively.

- Rainfall and river water level in the Itajaí River basin are observed by many institutions such as FURB/CEOPS (for flood forecasting), ANA (for water resource management), EPAGRI (for agriculture), and Celesc (for hydropower). Although CIRAM as the meteorological department of the SC State Government collects meteorological and hydrological data in the Itajaí River basin from these institutions, the collected data are not utilized for the FFWS.
- FURB/CEOPS currently carries out flood forecasting using water level correlation method on the commission from SDS, but the water level gauging stations does not function due to the lack of maintenance, and flood forecasting is implemented only for Blumenau City and not for the other cities.
- As for the evacuation activity, each city owns or is preparing evacuation manuals, and municipal organizations such as COMDEC and GRAC are responsible for the warning and evacuation activities. It seems that there are no serious problems except for the lack of hydrological data and delay of warning at night in some small, mountainous cities. Evacuation activities will be considered to be improved through the preparation of evacuation manuals and hazard maps throughout the basin.

As mentioned above, as current issues regarding the FFWS are attributed to the present government system of organizations, all organizations of SC State Government should fill each role for the observation, flood forecasting, warning and evacuation activities as shown in Figure 32.

- i) This study proposes the improvement of 14 existing gauging stations and 16 additional gauging stations so that all cities in the basin will be able to have the flood forecasting and warning system or early warning system. All of the 30 gauging stations must be managed

and maintained by the organization of the state government responsible for the FFWS (SDS/Defesa Civil).

- ii) The organization of state government responsible for the FFWS must improve the flood forecasting method and warning level not only for Blumenau, but also all the other cities in the basin.
- iii) On the other hand, EPAGRI/CIRAM, which is the organization responsible for the climate and weather condition, should establish new institutions and regulations to collect hydrological and meteorological data from the different organizations and transmit to the organization responsible for the FFWS. CIRAM should also develop a database system to store and utilize these data. These data shall be utilized for future development of advanced FFWS using runoff analysis, inundation analysis and rainfall forecasting.
- iv) The information from the flood forecasting system should be transmitted to all CD Municipal Councils in the basin so that the CD Municipal Councils can judge the warning and evacuation announcement based on the warning water level and forecasted water level.
- v) GRAC shall conduct evacuation activities based on the evacuation announcement. Defesa Civil of the state government, which is responsible for the prevention of natural disaster, should help to prepare the evacuation manual and hazard map for the cities that have not prepared yet.

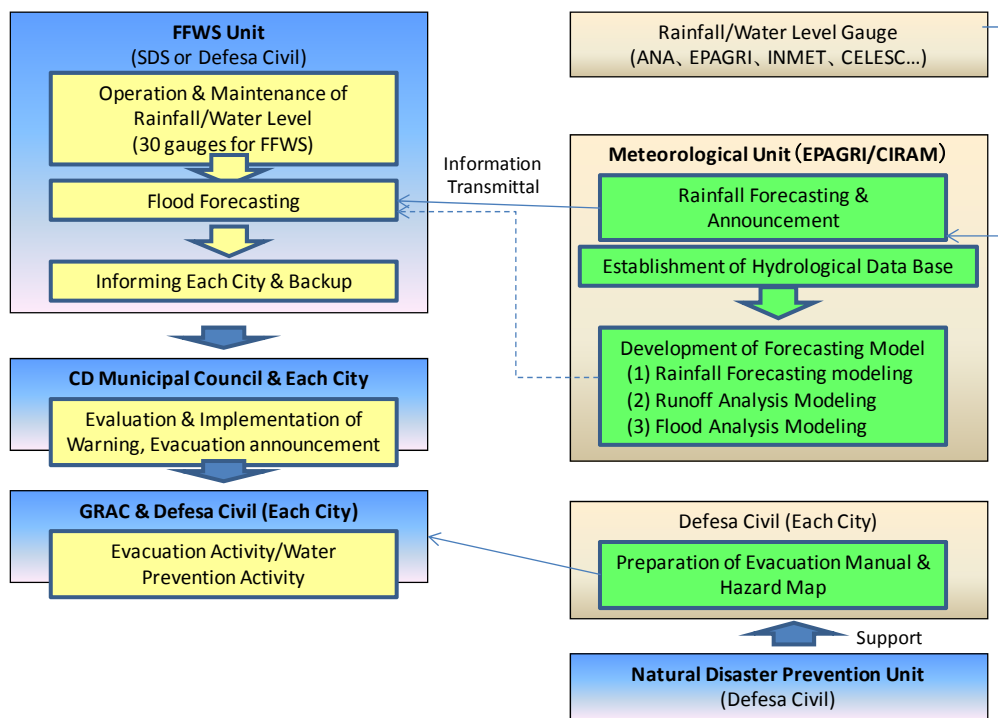

Source: JICA Survey Team

Figure 32 Proposed Institutional Organization for the FFWS

## 19. Feasibility Study on Structural Measures for Landslides

### 19.1 Basic Policy

All of the priority sites are road slopes. In addition, structural measures will be planned to ensure full width road traffic against 60 years of heavy rain. Moreover, there is a high possibility of losing human lives as evident on 13 priority sites. The type of measures to be considered will be selected by learning from the existing measures used on slopes with similar

conditions, in which a disaster have not occurred even under 60 years of heavy rain.

## 19.2 Landslide Type and Selection of Type of Structural Measures

Generally, the appropriate structural measures are different with regards to the type of landslide movement and landslide location from the preservation object. The selection criteria of structural measures against the mountainside slope are shown in Table 22.

**Table 22 Structural Measures Against Mountainside Collapse**

Slope Condition		Typical Measure Alternatives	Common Items
Stable cutting gradient is not secured		Rock bolts, anchor works.	Open ditch, vegetation
There is a probability of a rock fall		Removal of unstable rock, foot protection, rock protection fence, rock catch/cover net.	
Stable cutting gradient for deep collapse is secured	Slope height is more than 7 m.	Cutting of unstable portion, slope reinforcement works.	
	Slope height is less than 7 m	Cutting of unstable portion, vegetation net, and gabion on slope foot.	

Source: JICA Survey Team

Comparison of alternatives of cutting slope reinforcement measure for an area of 1,000 m<sup>2</sup> is carried out. Reinforced earth method of PP fiber/cement/sand is recommendable, because it is the most advantageous of all evaluation items considering the cost, construction period, and landscape. The selection criteria of structural measures against valley side slope collapse are shown in Table 23 below. Vegetation works and open ditch are included in the basic measures to prevent sediment discharge.

**Table 23 Structural Measures Against Valley Side Collapse**

Slope Condition		Typical Measure Alternatives		Common Item
Height (H) of collapse H>10	Height (H) and width (W) of collapse H/W > 0.5		Pilling, or large block placing	Tree planting Open ditch
	Height (H) and width (W) of collapse H/W ≤ 0.5		Gully filling by gabion and longitudinal drainage	
Height (H) of collapse H ≤ 10	Height (H) and width (W) of collapse H/W > 0.5	Embankment on slope foot is Possible	Embankment	
		Embankment on slope foot is Impossible	Pilling, or large size block placing	
	Height (H) and width (W) of collapse H/W ≤ 0.5		Gully filling by gabion and longitudinal drainage	

Source: JICA Survey Team

Selections of measures for two river bank slope collapse (priority No. 2 SC 470 Gaspar River Bank, priority No. 3 Blumenau - AV. Pres Casrelo Branco) are conducted by considering the river flow rate and advantage for environment preservation. From the viewpoint of environment and landscape preservation, revetment types, which enable soil covering and vegetation, are adopted. No. 2 SC 470 Gaspar River Bank, gabion revetment is adapted by considering flow rate. No. 3 Blumenau AV. Pres Casrelo Branco, revetment of connecting concrete blocks is adopted to protect the local water attack caused by bridge pier neighboring the site.

Among the four landslide sites, a design safety factor of 1.15 is obtained by groundwater drainage and gabion retaining wall. For the site of the priority No. 9 SC477 Benedito Novo - Doutor Pedrinho 1, groundwater drainage is not appropriate, because the groundwater table is initially low. Lightweight embankment by EPS (expanded polystyrene) is appropriate for the site condition of deep foundation rock and low groundwater.

**Table 24 List of Structural Measures and Result of Stability Analysis**

No. of Priority Order	Site	IFS: Initial Factor of Safety	DFS: Design Factor of safety	Safety Factor After Groundwater Drainage or Lightweight Embankment	Measure
1	SC 302 Taio-Passo Manso-5	1.00	1.15	1.14 by 1.0 m lowering of groundwater table. 1.20 by 1.5 m lowering of groundwater table.	Horizontal drainage drilling Gabion retaining wall
4	SC418 Blumenau - Pomerode	1.00	1.15	1.15 by 0.5 m lowering of groundwater table.	Closed conduit with open ditch, Gabion retaining wall
6	Gaspar - Luiz Alves, Gaspar 9	1.00	1.15	1.150 by 1.0 m lowering of groundwater table.	Horizontal drainage drilling Gabion retaining wall
9	SC477 Benedito Novo - Doutor Pedrinho I	1.00	1.15	1.15 by lightweight embankment.	Lightweight embankment

Source: JICA Survey Team

## 20. Feasibility Study on Early Warning System for Landslide and Flash Flood

### 20.1 Method of Rainfall Monitoring, Data Communication, and Repository

An automatic rain gauge will be installed in each city for the early warning purpose. Location of automatic rain gauge will be determined by the following procedure. Redundant data communication will be established by both VHS (very high frequency connection) of Celes system and GPRS (general packet radio services) to secure information communication even under stormy conditions. If some automatic rain gauges are installed in a municipality, Defesa Civil-SC will discuss in which effective areas are the new automatic rain gauges to be installed. These are most likely to be installed in areas with high population density and are at high risks of having landslide/flash flood.

### 20.2 Criteria of Rainfall Index for Attention/Alarm

There is no available landslide/flash flood database which provides the exact time and location of occurrence of the landslide/flash flood. The rainfall monitoring stations are sparse. Therefore, the appropriate criteria setting is not possible so far and it shall be conducted when the exact disaster database is already furnished.

### 20.3 Management of Information, Calculation of Rainfall Index, and Issuance/Announcement of Attention/Alarm

The attention and alarm are formally issued by Defesa Civil-SC. Since early information for the public is important, Defesa Civil-SC delegates EPAGRI/CIRAM the announcement of the rainfall level of attention/warning through a web page and/or mass media, as a part of routine or emergency weather report. The computer for the early warning system shall include the function of automatic sending electronic mail to the Defesa Civil-SC, mayor/Defesa civil staff of each city, and EPAGRI/CIRAM staff in charge.

### 20.4 Evacuation Order and Disaster Education

The municipalities and/or mayors are the responsible officials in giving the evacuation order. Evacuation will be ordered for the designated houses which are at risk when the rainfall index reaches the alarm level. The evacuation will also be ordered if visible signs of disasters are found out.

The Defesa Civil of the municipalities will prepare the detailed hazard map (S=1:10,000), and will designate the areas/houses at risk, emergency evacuation buildings such as schools and/or churches, and evacuation route. The disaster education about the evacuation will also be

conducted. The State of Santa Catarina shall clarify the responsibility of the municipalities and/or mayors about the evacuation order in a law. Generally, the capacity of a municipality is not enough for the evacuation order. The Defesa Civil-SC shall coordinate the support of the municipalities by using human resources of universities, engineer of public/private entities, and/or international technical assistance. The early warning system shall be started as soon as possible. Then, the areas/houses at risk which shall be evacuated would be designated one by one by the maximum effort of municipalities to further develop the early warning system.

#### **20.5 Road Traffic Regulation for Risk Avoidance**

Traffic regulation will be ordered to the designated disaster-prone road section when the rainfall index reaches the alarm level. The traffic regulation will be ordered when disaster signs associated with landslide/flash flood are found out. The disaster-prone road sections would be designated one by one to further develop the early warning system. After the completion of the structural measures, the designations of disaster prone road sections for early warning will be removed. The municipality is responsible for the municipality roads while DEINFRA is responsible for state roads, the road traffic regulation, and risk avoidance.

### **21. Environmental and Social Consideration**

#### **21.1 Review of Initial Environment Examination (IEE) in the Master Plan Study**

Based on the scoping matrix, land acquisition and relocation of local people were identified as important environmental and social impacts due to the heightening of the two existing dams. Mitigation measures for the expected impacts were studied.

#### **21.2 Mitigation Measures for Environmental and Social Impacts**

##### **(1) Sul Dam**

As the existing spillway crest will be heightened by 2 m, the dam crest is not necessary to be heightened. As DNOS (former Federal Government who constructed Sul and Oeste Dam) has already acquired the potential inundation areas up to EL. 410.0 m at the construction of Sul Dam, no further land acquisition will be required for this component. However, DNOS made an agreement with COOPERBASUL on the use of the lands extended from EL. 405.5 m to EL. 410.0 m in 1981, which have been rarely inundated. As the agreement does not include a compensation clause on any damages caused by inundation, the state government shall review and revise the current agreement with COOPERBASUL so as to ensure that COOPERBASUL could get compensation when such areas are inundated.

It appeared through the field survey that six buildings, which consist of four houses with kiosk and two log cabins, were confirmed from EL. 401.276 m to EL. 409.314 m. To date, there have been no major conflicts raised between COOPERBASUL and the state government about the use of the target area of land use concession in spite of a possible increase in the water level of the inundation area. Since the heightened dam structure could slightly increase the probability of inundation at the target area for land use concession, it is expected that the heightening of Sul Dam could cause a very small amount of negative impacts. It is recommended that DEINFRA shall discuss with COOPERBASUL to revise the current contract of land use concession considering the possible impacts which are assumed to be caused by the proposed dam heightening.

##### **(2) Oeste Dam**

The dam and spillway crests of Oeste Dam will be heightened by 2 m, and therefore the heights of both crests will be EL. 365.16 m and EL. 362.3 m, respectively. Although DEINFRA has already acquired the potential inundation areas up to EL. 363.0 m, there is still a need to acquire

the rest of the potential areas up to the height of the planned dam crest (EL. 365.16 m). In other words, the heightening of Oeste Dam is expected to affect households/communities residing in the potential inundation areas from El. 363.0 m to 365.16 m. With provision of relocation of elevated road to surround the houses that are to be relocated, resettlement issues would be avoided.