

REV. No.	DATE	DESCRIPTION
1		
2		
3		

SCALE: H=1:2,000 V=1:200	DRAWING No. C-212
-----------------------------	-------------------

THE PROJECT FOR IMPROVEMENT OF NATIONAL ROAD No.9 AS EAST-WEST ECONOMIC CORRIDOR IN LAO PDR	MINISTRY OF PUBLIC WORKS AND TRANSPORT LAO PEOPLE'S DEMOCRATIC REPUBLIC
--	--

JAPAN INTERNATIONAL COOPERATION AGENCY THE CONSORTIUM OF ORIENTAL CONSULTANTS CO., LTD. INTERNATIONAL DEVELOPMENT CENTER OF JAPAN	MINISTRY OF PUBLIC WORKS AND TRANSPORT LAO PEOPLE'S DEMOCRATIC REPUBLIC
--	--

TITLE	NAME	SIGNATURE
PREPARED BY		
CHECKED BY		
APPROVED BY		

DRAWING TITLE	SECTION 2: STA. 127+000 - 127+700
PLAN & PROFILE	

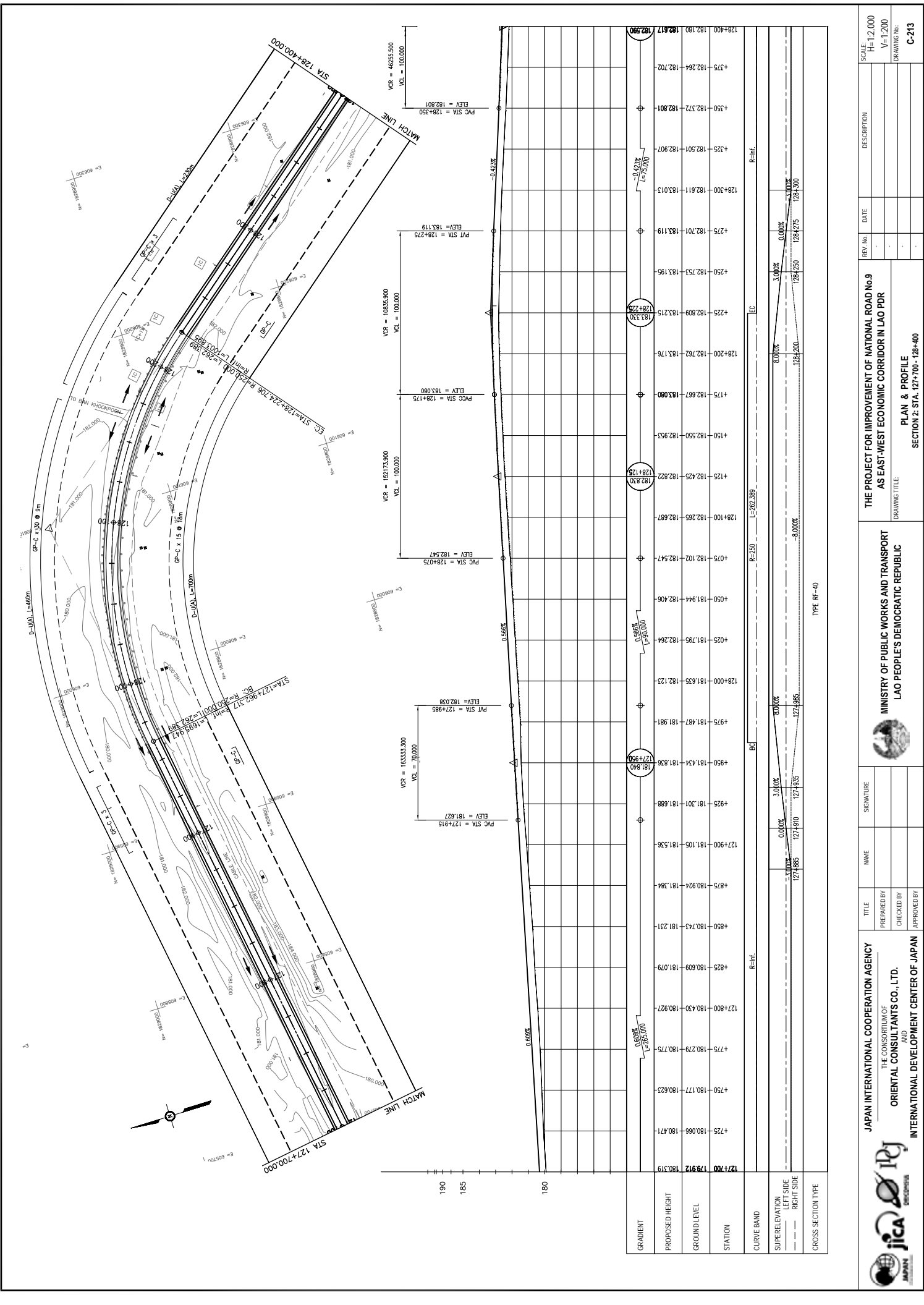

REV No.	DATE	DESCRIPTION	SCALE
1			H=1:2,000
2			V=1:200

JAPAN INTERNATIONAL COOPERATION AGENCY THE CONSORTIUM OF ORIENTAL CONSULTANTS CO., LTD. INTERNATIONAL DEVELOPMENT CENTER OF JAPAN		MINISTRY OF PUBLIC WORKS AND TRANSPORT LAO PEOPLE'S DEMOCRATIC REPUBLIC	
TITLE PREPARED BY CHECKED BY APPROVED BY		PROJECT TITLE THE PROJECT FOR IMPROVEMENT OF NATIONAL ROAD No.9 AS EAST-WEST ECONOMIC CORRIDOR IN LAO PDR	
DRAWING No. C-213		SECTION 2: STA. 127+700 - 128+400 PLAN & PROFILE	

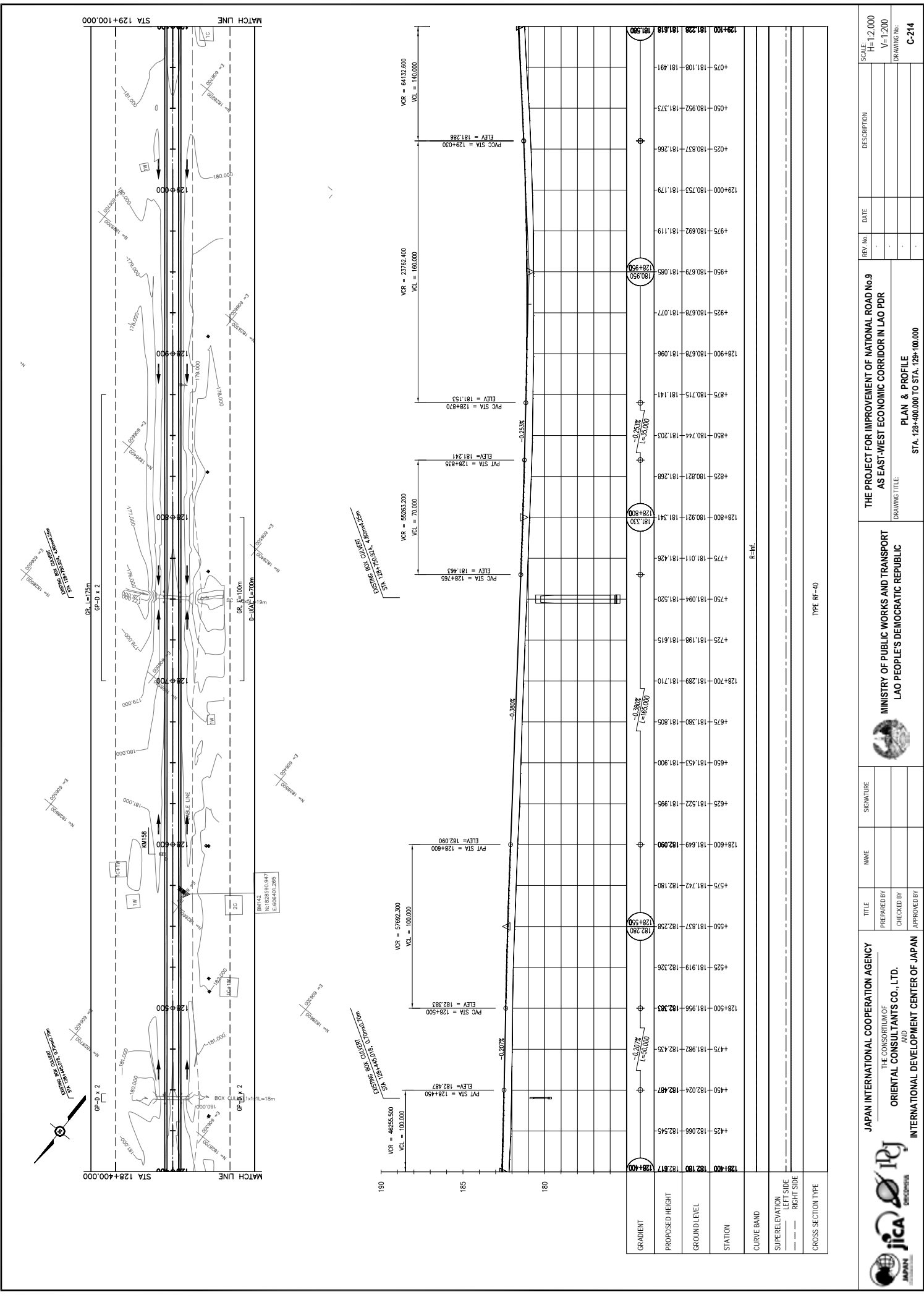

REV. No.	DATE	DESCRIPTION

SCALE:	H=1:2,000
	V=1:200

DRAWING TITLE		PLAN & PROFILE
DRAWING No.		STA. 128+400.000 TO STA. 129+100.000

JAPAN INTERNATIONAL COOPERATION AGENCY		MINISTRY OF PUBLIC WORKS AND TRANSPORT	
THE CONSORTIUM OF		LAO PEOPLE'S DEMOCRATIC REPUBLIC	
ORIENTAL CONSULTANTS CO., LTD.			
INTERNATIONAL DEVELOPMENT CENTER OF JAPAN			

TITLE	NAME	SIGNATURE
PREPARED BY		
CHECKED BY		
APPROVED BY		

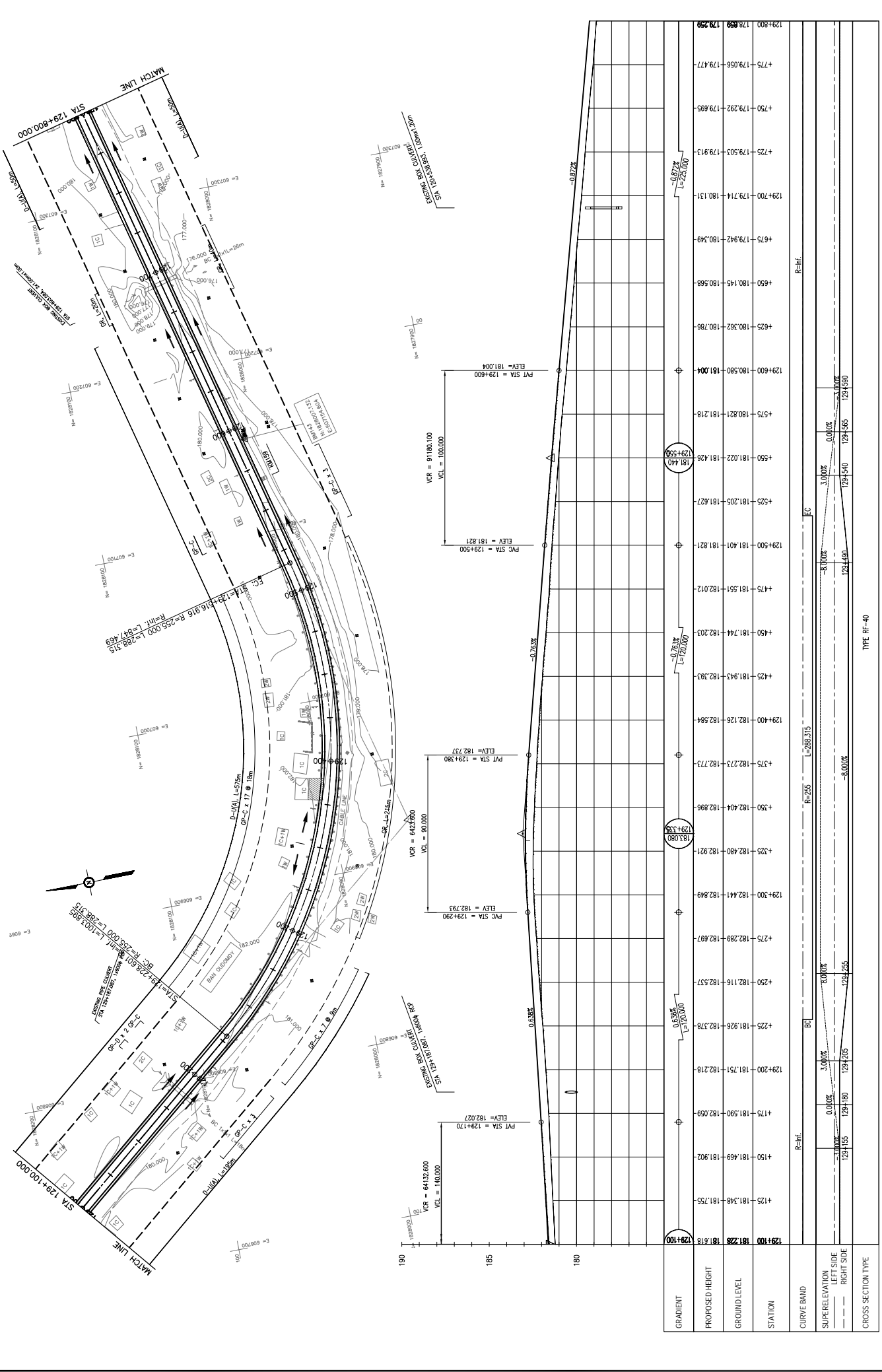

STATION	ELEVATION	GRADIENT
129+800	179.850	179.850 - 179.477
129+750	179.056	179.292 - 179.695
129+700	179.503	179.913 - 180.131
129+650	180.145	180.349 - 180.568
129+600	180.580	180.786 - 181.004
129+550	181.426	181.218 - 181.436
129+500	181.821	181.627 - 181.845
129+450	181.551	182.012 - 182.230
129+400	181.744	182.203 - 182.421
129+350	181.943	182.393 - 182.611
129+300	182.126	182.584 - 182.802
129+250	182.273	182.775 - 182.993
129+200	182.404	182.986 - 183.204
129+150	182.480	182.921 - 183.139
129+100	182.441	182.849 - 183.067
129+050	182.289	182.697 - 182.915
129+000	182.116	182.537 - 182.755
128+950	181.926	182.378 - 182.596
128+900	181.751	182.218 - 182.436
128+850	181.590	182.059 - 182.277
128+800	181.469	181.902 - 182.120
128+750	181.348	181.755 - 181.973
128+700	181.228	181.618 - 181.836

JAPAN INTERNATIONAL COOPERATION AGENCY
 THE CONSORTIUM OF
ORIENTAL CONSULTANTS CO., LTD.
 INTERNATIONAL DEVELOPMENT CENTER OF JAPAN

MINISTRY OF PUBLIC WORKS AND TRANSPORT
LAO PEOPLE'S DEMOCRATIC REPUBLIC

THE PROJECT FOR IMPROVEMENT OF NATIONAL ROAD No.9
AS EAST-WEST ECONOMIC CORRIDOR IN LAO PDR

PLAN & PROFILE
 SECTION 2: STA. 129+100 - 129+800

REV. No.	DATE	DESCRIPTION

SCALE: H=1:2,000
 V=1:200
 DRAWING No. **D-215**

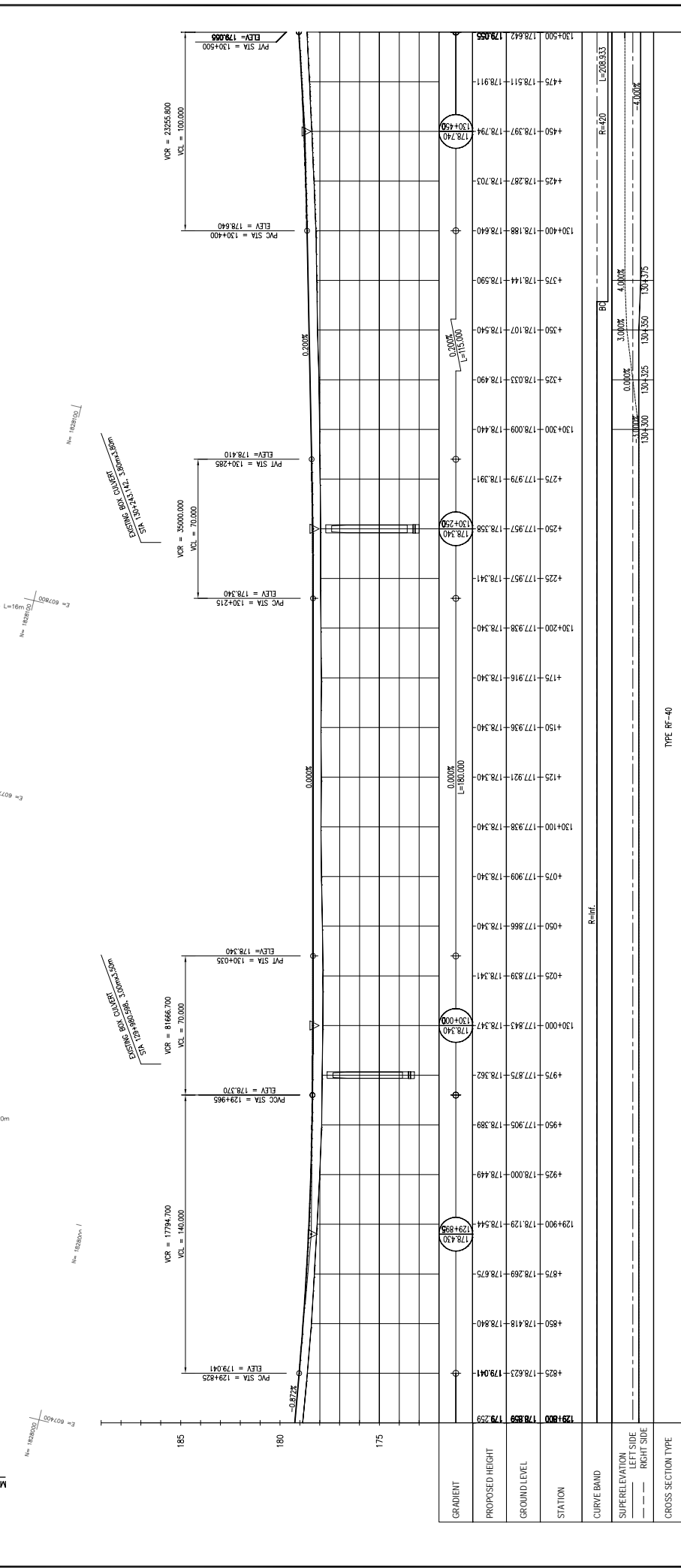
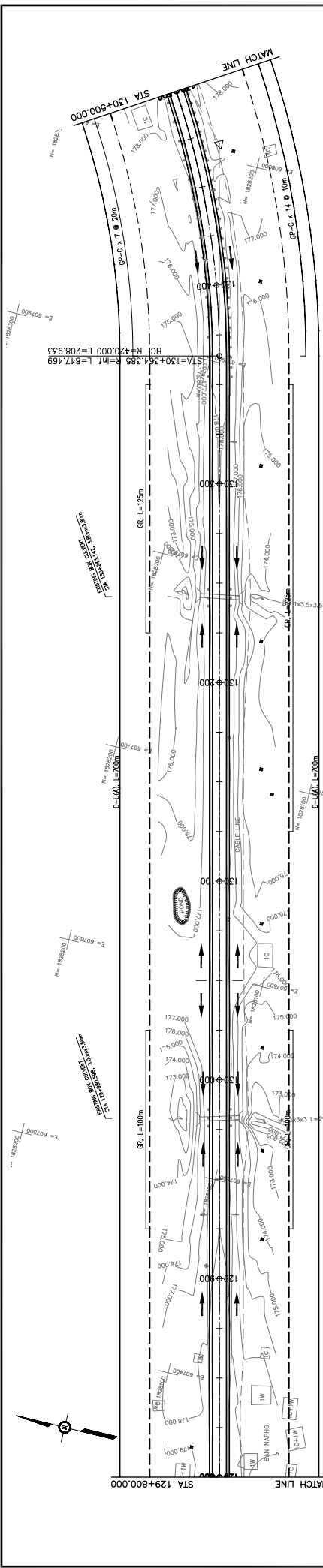

STATION	ELEVATION	PROPOSED HEIGHT	GROUND LEVEL
129+800	178.859	178.259	178.859
129+825	178.623	179.041	178.840
129+850	178.418	178.840	178.840
129+875	178.269	178.675	178.675
129+900	178.129	178.544	178.544
129+925	178.000	178.449	178.449
129+950	177.905	178.389	178.389
129+975	177.875	178.362	178.362
130+000	177.843	178.347	178.347
130+025	177.839	178.341	178.341
130+050	177.866	178.340	178.340
130+075	177.909	178.340	178.340
130+100	177.938	178.340	178.340
130+125	177.921	178.340	178.340
130+150	177.936	178.340	178.340
130+175	177.916	178.340	178.340
130+200	177.938	178.340	178.340
130+225	177.957	178.341	178.341
130+250	177.957	178.341	178.341
130+275	177.979	178.391	178.391
130+300	178.009	178.440	178.440
130+325	178.035	178.490	178.490
130+350	178.107	178.540	178.540
130+375	178.144	178.590	178.590
130+400	178.188	178.640	178.640
130+425	178.287	178.703	178.703
130+450	178.397	178.794	178.794
130+475	178.511	178.911	178.911
130+500	178.642	179.055	179.055

JAPAN INTERNATIONAL COOPERATION AGENCY
 THE CONSORTIUM OF
ORIENTAL CONSULTANTS CO., LTD.
 INTERNATIONAL DEVELOPMENT CENTER OF JAPAN

MINISTRY OF PUBLIC WORKS AND TRANSPORT
LAO PEOPLE'S DEMOCRATIC REPUBLIC

THE PROJECT FOR IMPROVEMENT OF NATIONAL ROAD No.9
AS EAST-WEST ECONOMIC CORRIDOR IN LAO PDR

PLAN & PROFILE
 SECTION 2: STA. 129+800 - 130+500

REV. No.	DATE	DESCRIPTION

SCALE: H=1:2,000
 V=1:200
 DRAWING No. C-216

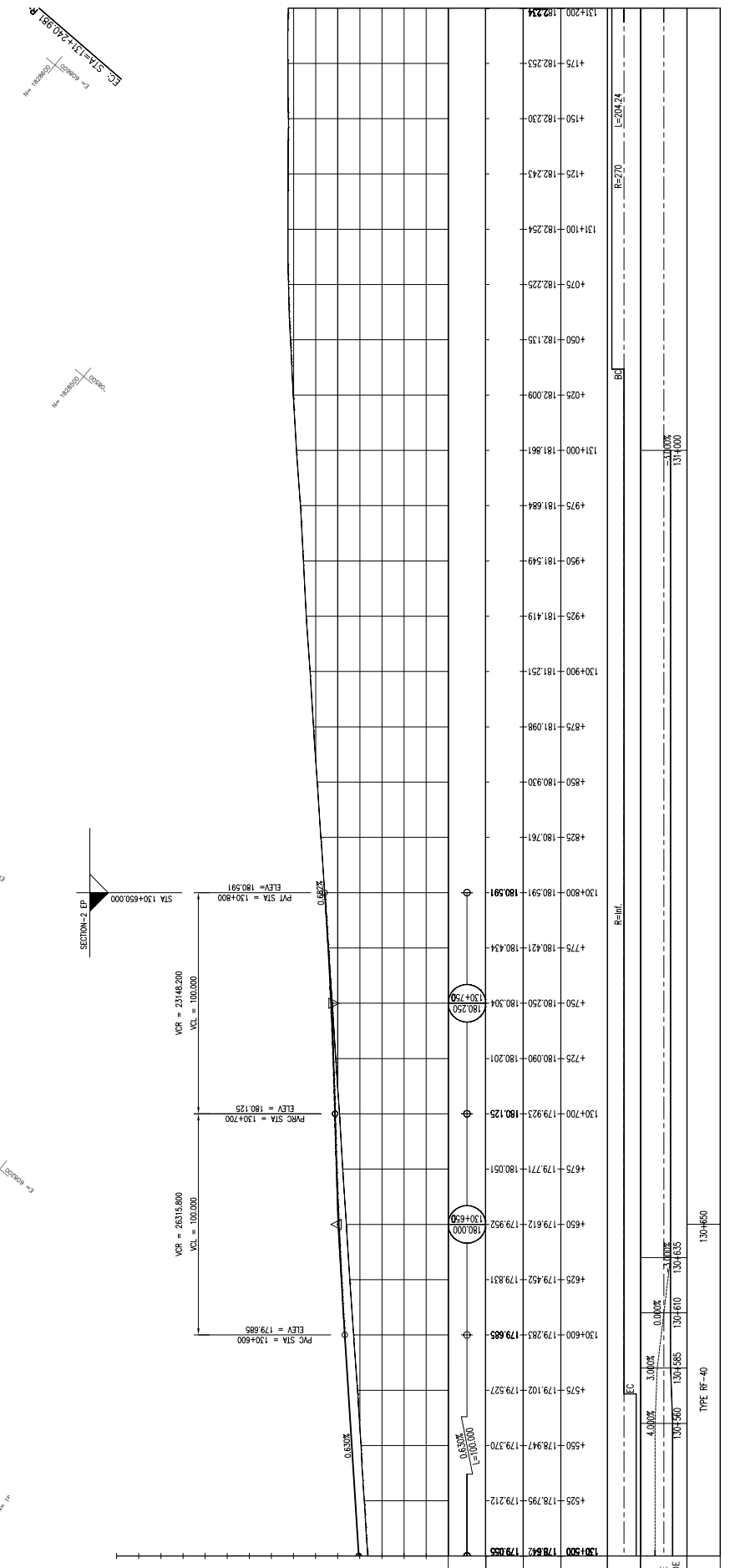
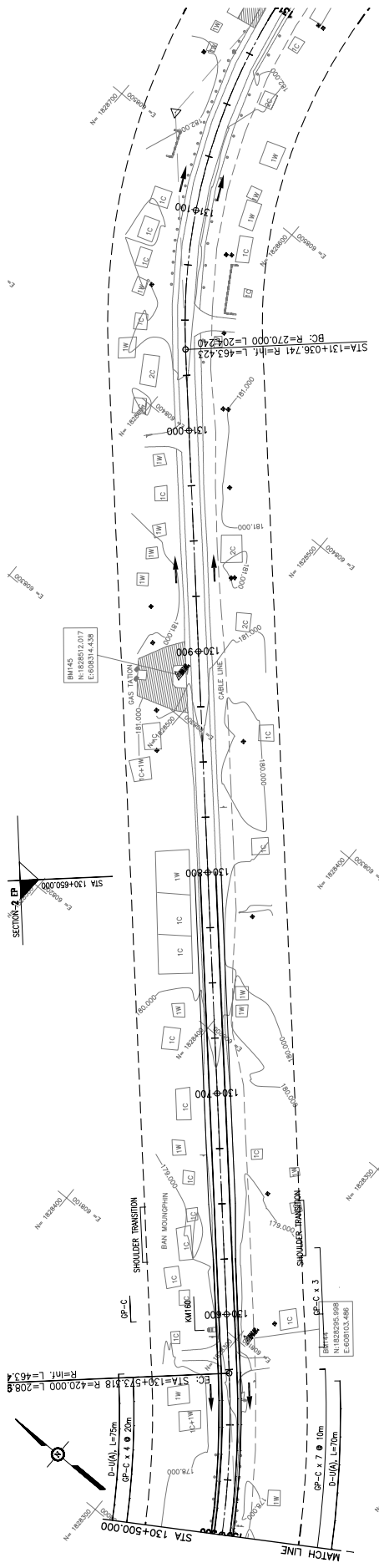

STATION	PROPOSED HEIGHT	GROUND LEVEL	GRADIENT
130+500	178.642	179.055	0.650%
130+600	179.283	179.885	0.650%
130+700	179.923	180.125	0.650%
130+800	180.591	180.591	0.650%
130+900	181.251	181.251	0.650%
131+000	181.961	181.961	0.650%
131+100	182.254	182.254	0.650%
131+200	182.234	182.234	0.650%

REV. No.	DATE	DESCRIPTION

SCALE	H=1:2,000	V=1:200

JAPAN INTERNATIONAL COOPERATION AGENCY
 THE CONSORTIUM OF
ORIENTAL CONSULTANTS CO., LTD.
 INTERNATIONAL DEVELOPMENT CENTER OF JAPAN

MINISTRY OF PUBLIC WORKS AND TRANSPORT
LAO PEOPLE'S DEMOCRATIC REPUBLIC

THE PROJECT FOR IMPROVEMENT OF NATIONAL ROAD No.9
AS EAST-WEST ECONOMIC CORRIDOR IN LAO PDR
PLAN & PROFILE
 SECTION 2: STA. 130+500 - 131+000
 DRAWING TITLE

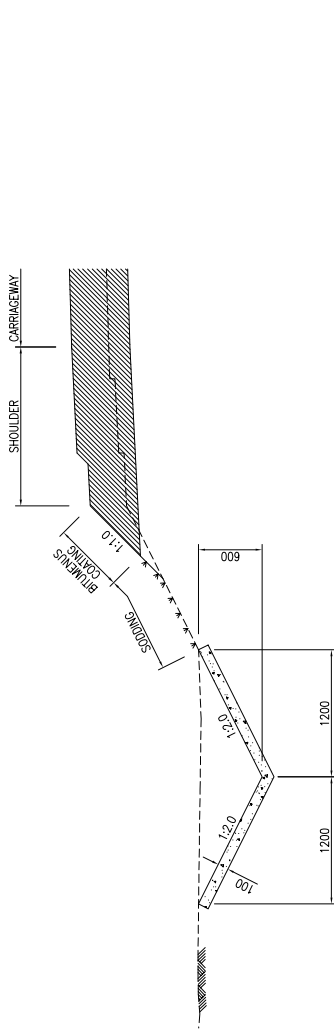

CONCRETE DITCH D-U(A)

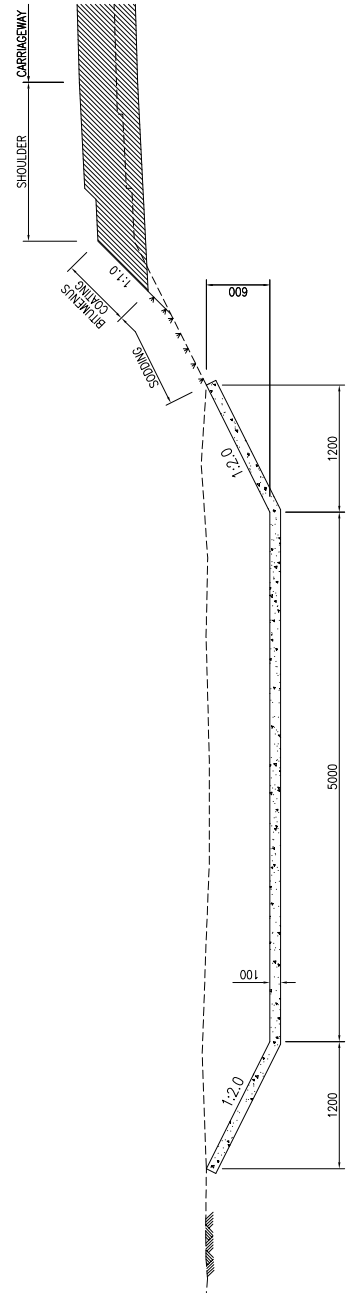

CONCRETE DITCH D-U(B)

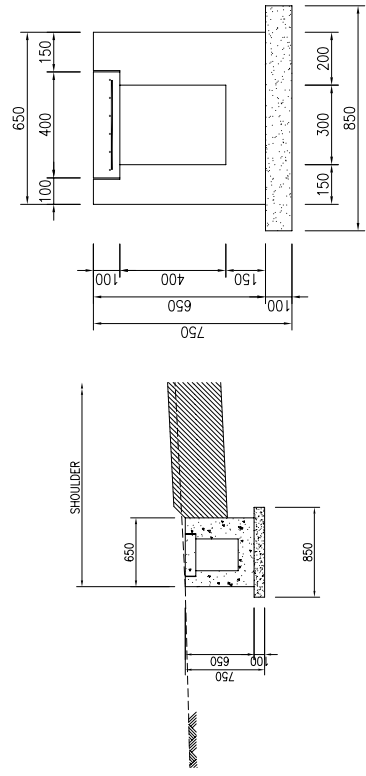

U-TYPE DITCH D-U(C)

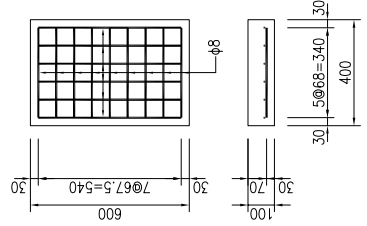

NOTES:

ALL DIMENSIONS ARE IN MILLIMETERS UNLESS OTHERWISE INDICATED.

JAPAN INTERNATIONAL COOPERATION AGENCY THE CONSORTIUM OF ORIENTAL CONSULTANTS CO., LTD. INTERNATIONAL DEVELOPMENT CENTER OF JAPAN	TITLE PREPARED BY CHECKED BY APPROVED BY	NAME SIGNATURE	THE PROJECT FOR IMPROVEMENT OF NATIONAL ROAD No.9 AS EAST-WEST ECONOMIC CORRIDOR IN LAO PDR		REV. No. 0 DATE	DESCRIPTION SCALE 1:200
			DRAWING TITLE DETAILS OF DRAINAGE DITCH		1 2 3	DRAWING No. D-01
			MINISTRY OF PUBLIC WORKS AND TRANSPORT LAO PEOPLES DEMOCRATIC REPUBLIC			



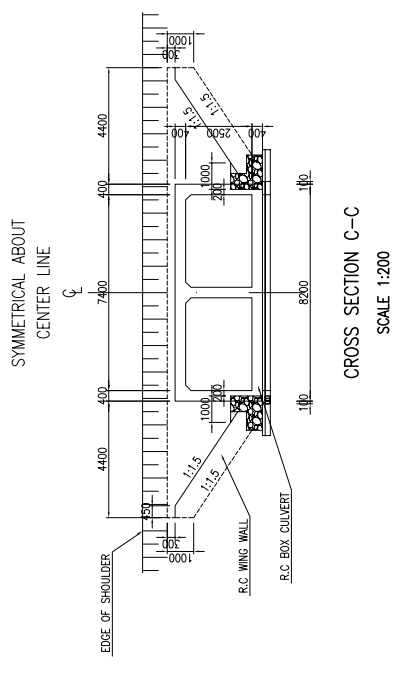
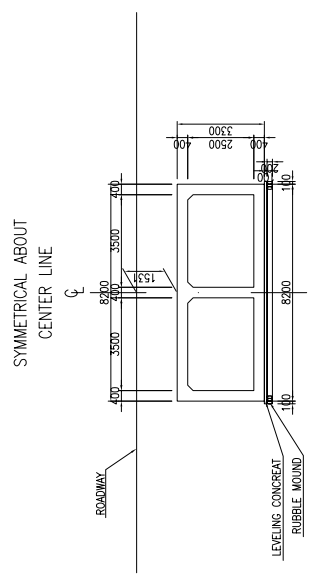
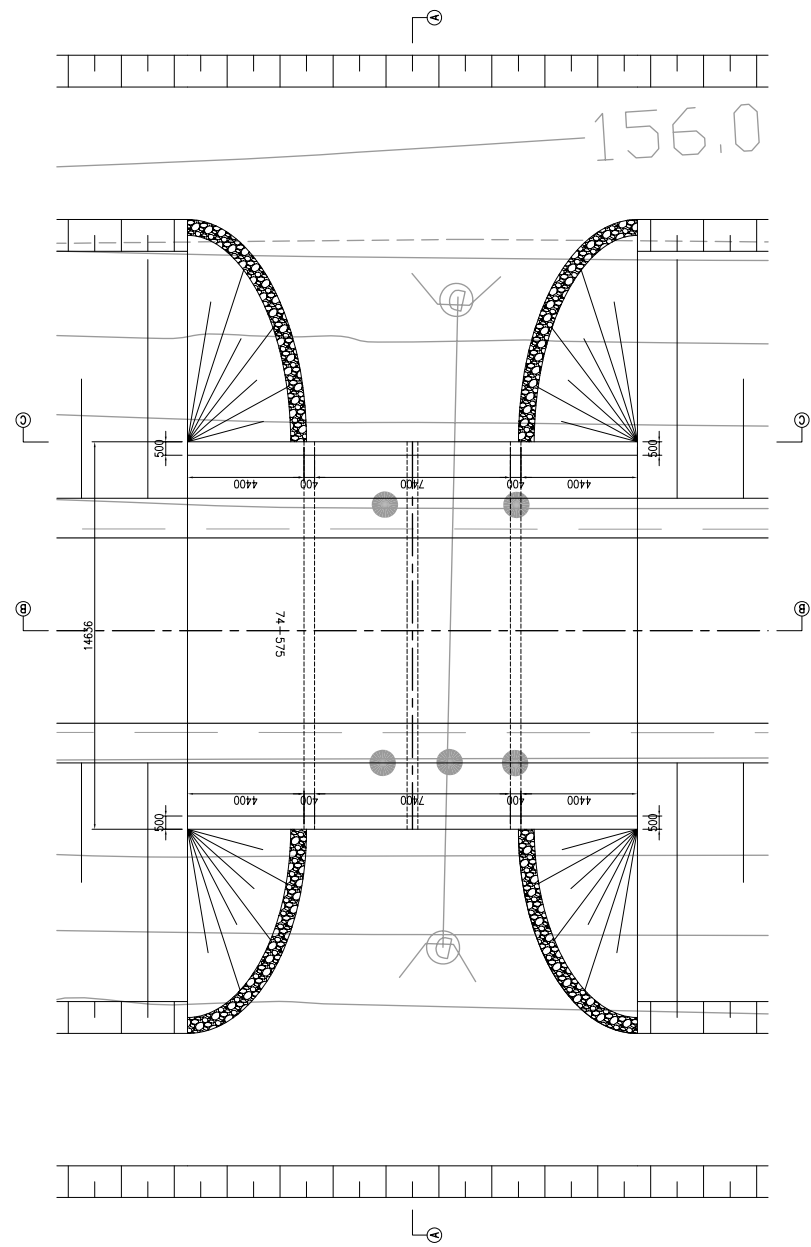
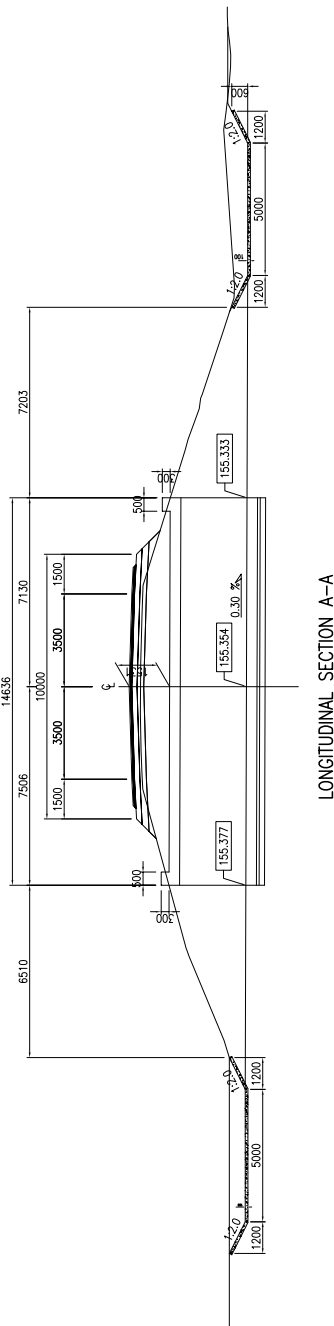

JAPAN INTERNATIONAL COOPERATION AGENCY
THE CONSORTIUM OF
ORIENTAL CONSULTANTS CO., LTD.
INTERNATIONAL DEVELOPMENT CENTER OF JAPAN

MINISTRY OF PUBLIC WORKS AND TRANSPORT
LAO PEOPLE'S DEMOCRATIC REPUBLIC

THE PROJECT FOR IMPROVEMENT OF NATIONAL ROAD No.9
AS EAST-WEST ECONOMIC CORRIDOR IN LAO PDR



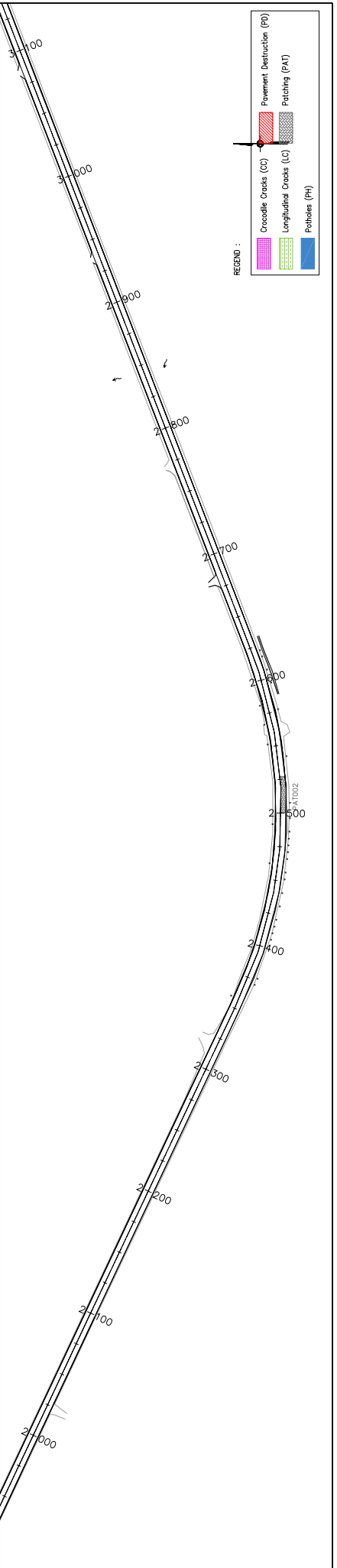
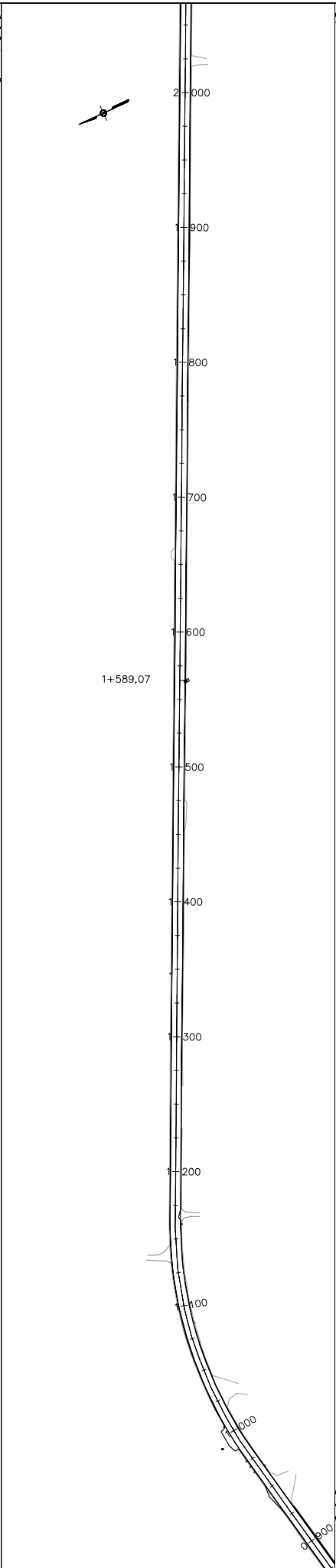
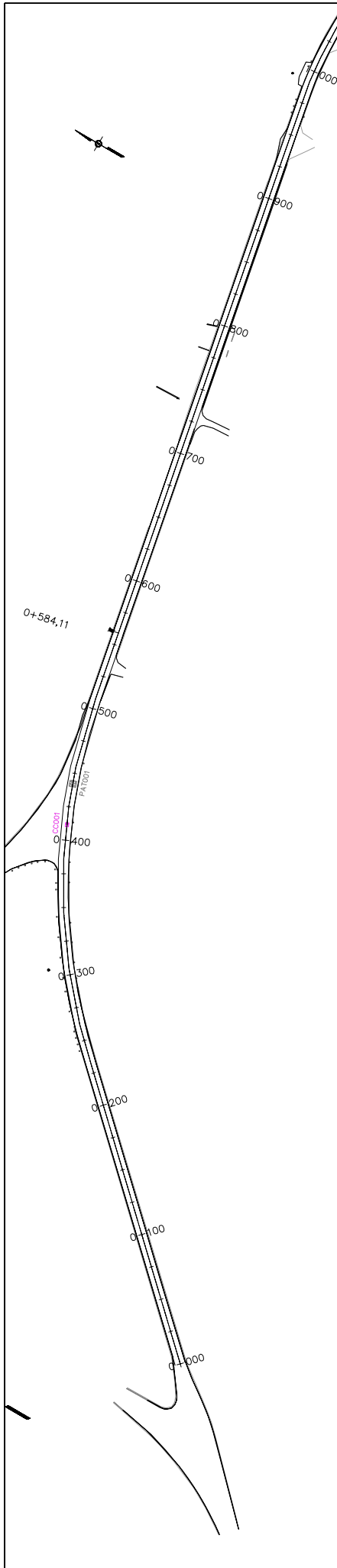

DRAWING TITLE: BOX CULVERT STRUCTURE

REV. No.	DATE	DESCRIPTION	SCALE
1			1:200
DRAWING No.:			D-02

(8) 路面調査結果



LEGEND :

	Crcodile Cracks (CC)		Pavement Destruction (PD)
	Longitudinal Cracks (LC)		Patching (PAT)
	Potholes (PH)		

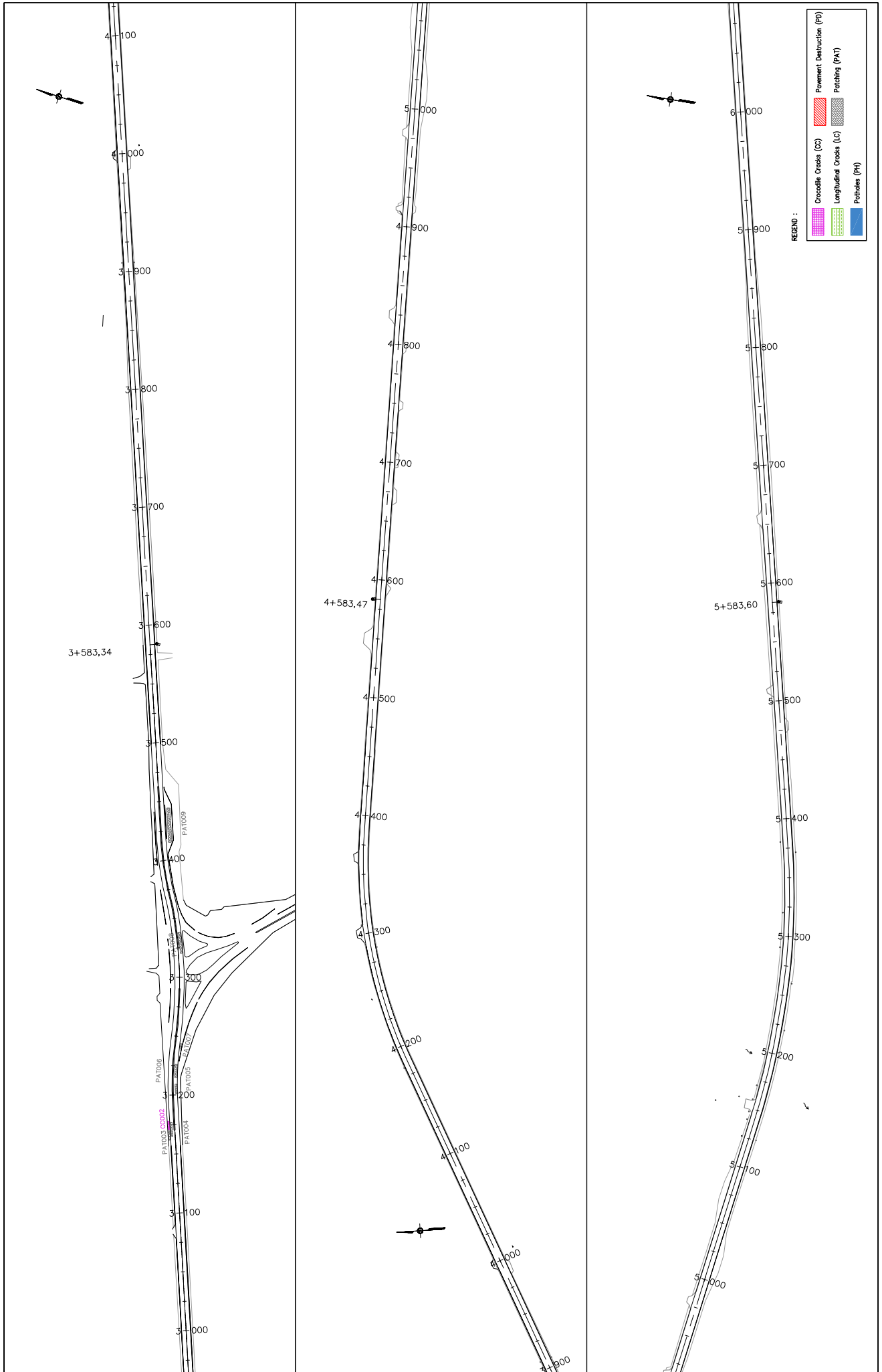

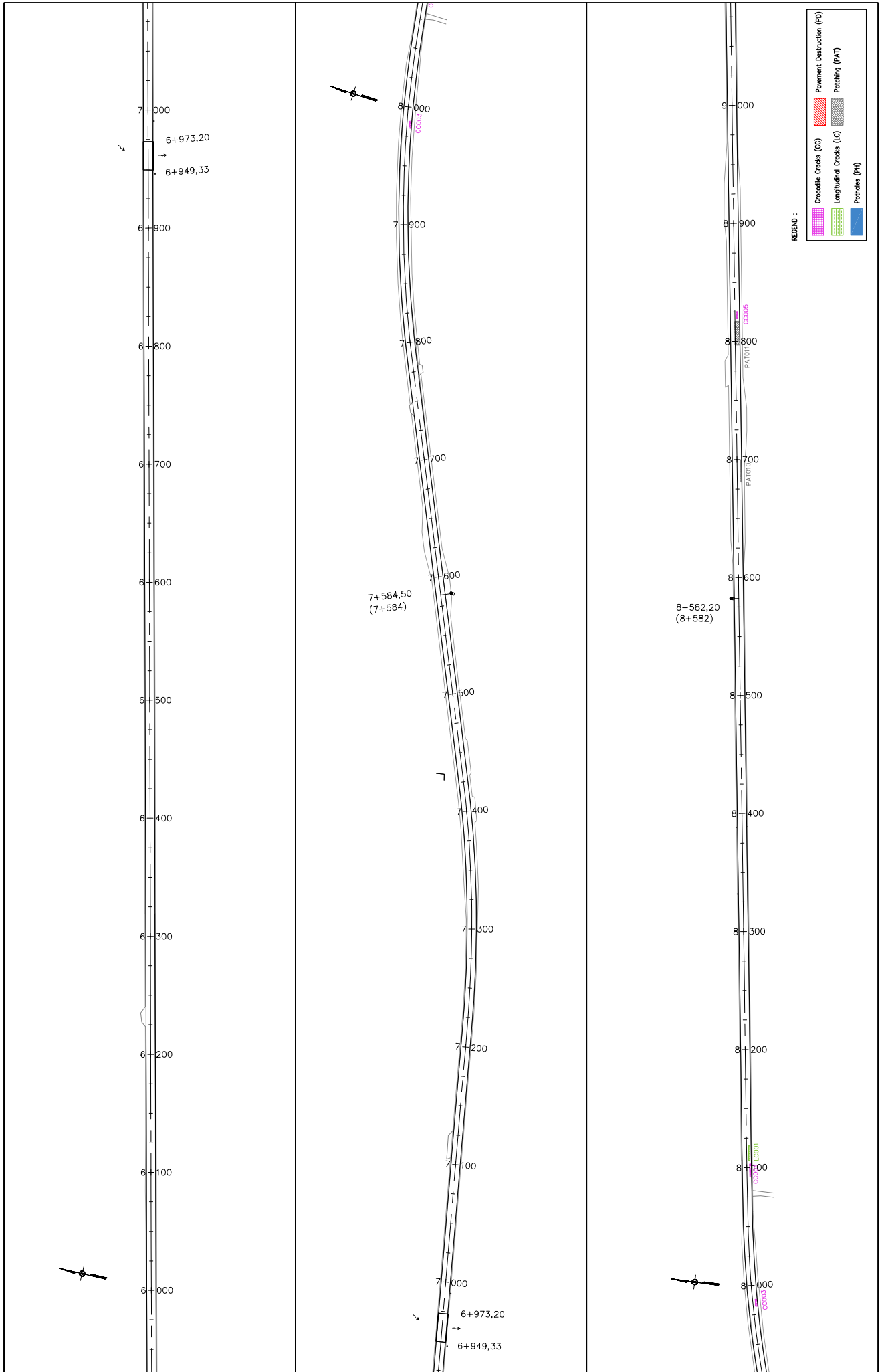





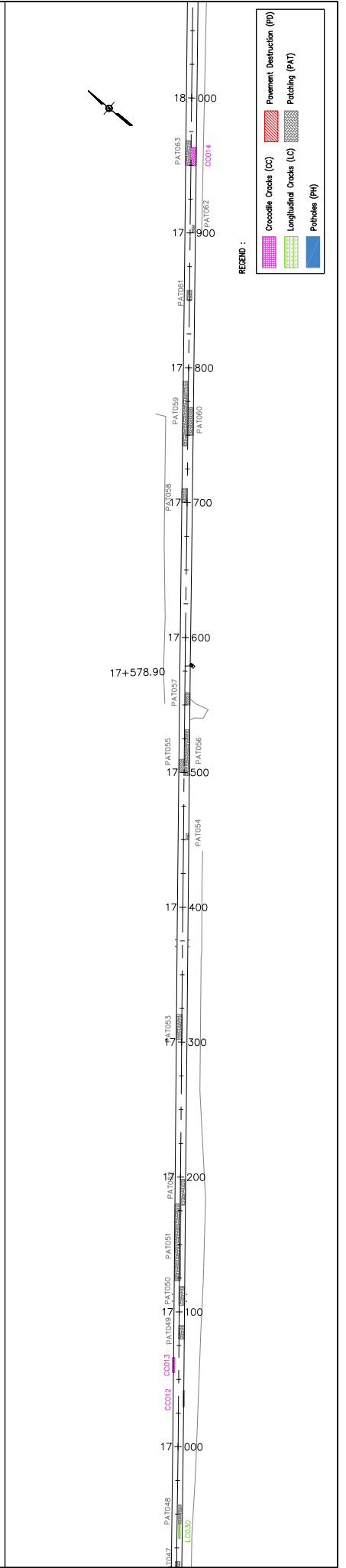
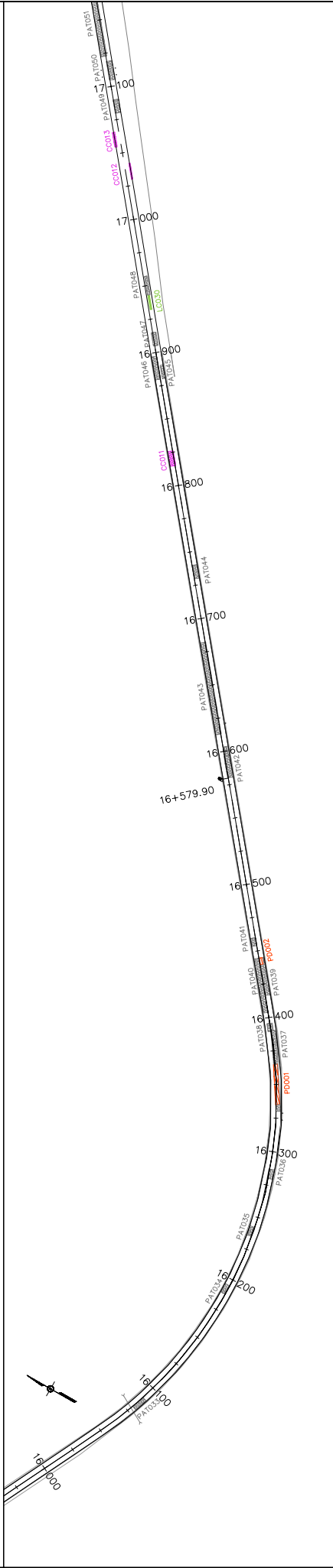
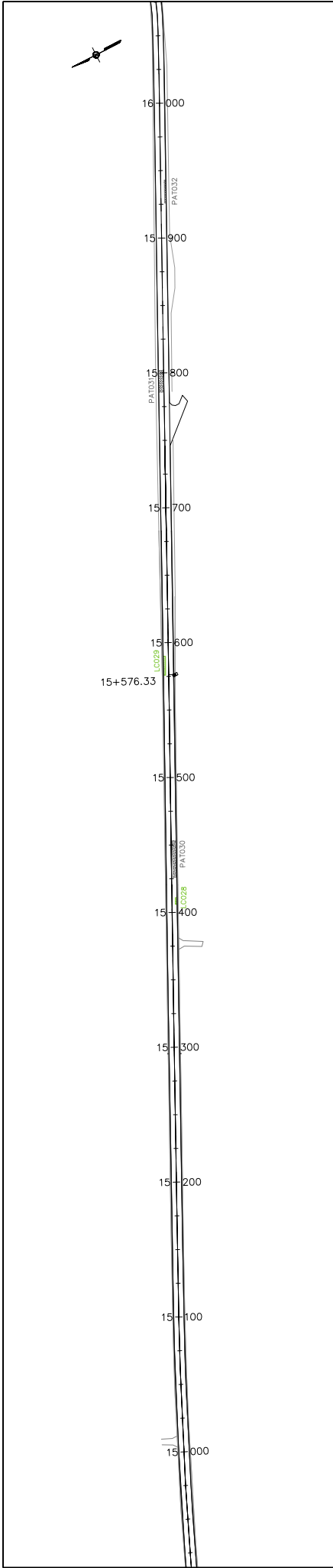

REGENO :

	Crocodile Cracks (CC)		Pavement Destruction (PD)
	Longitudinal Cracks (LC)		Patching (PAT)
	Potholes (PH)		

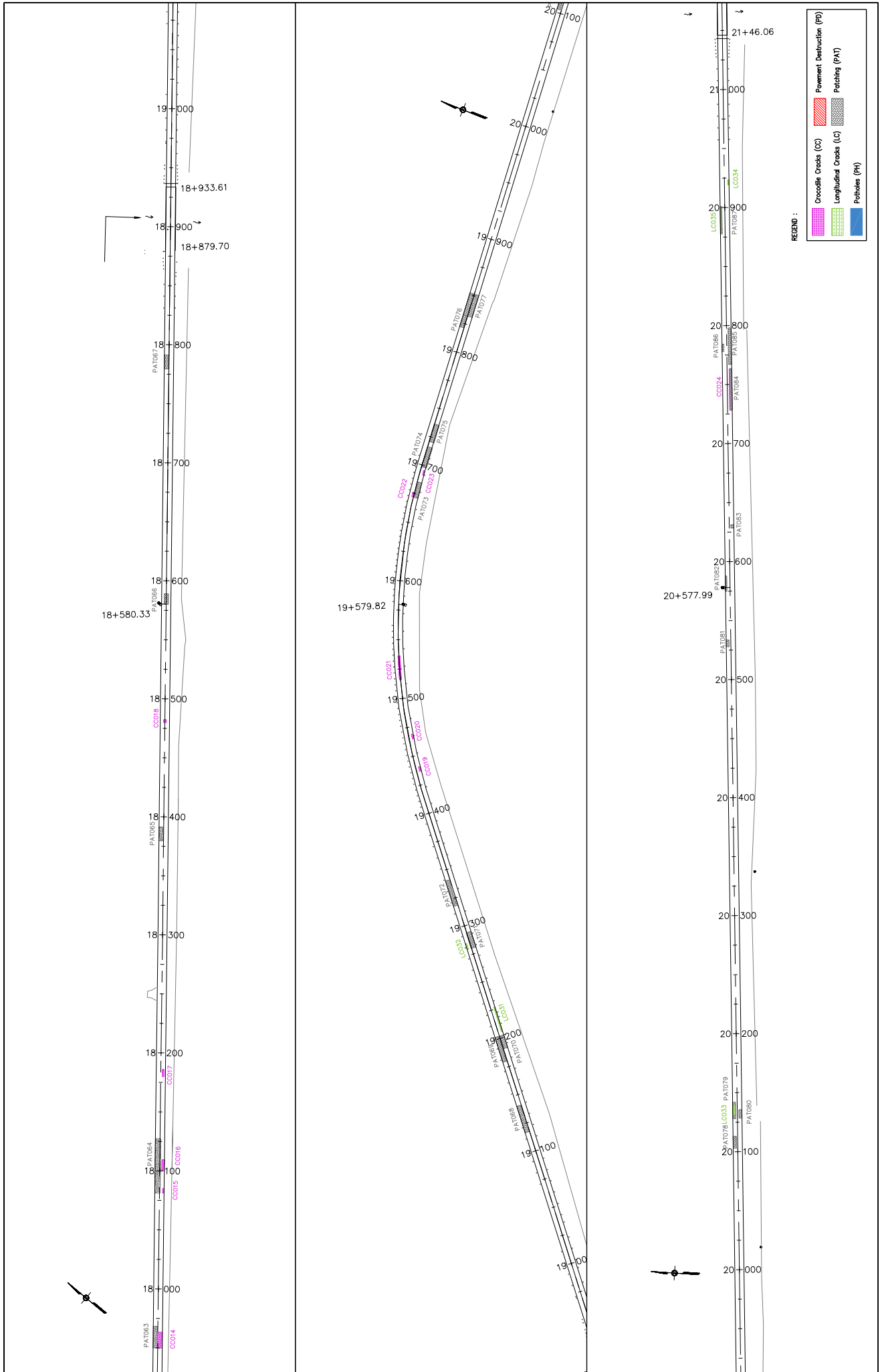

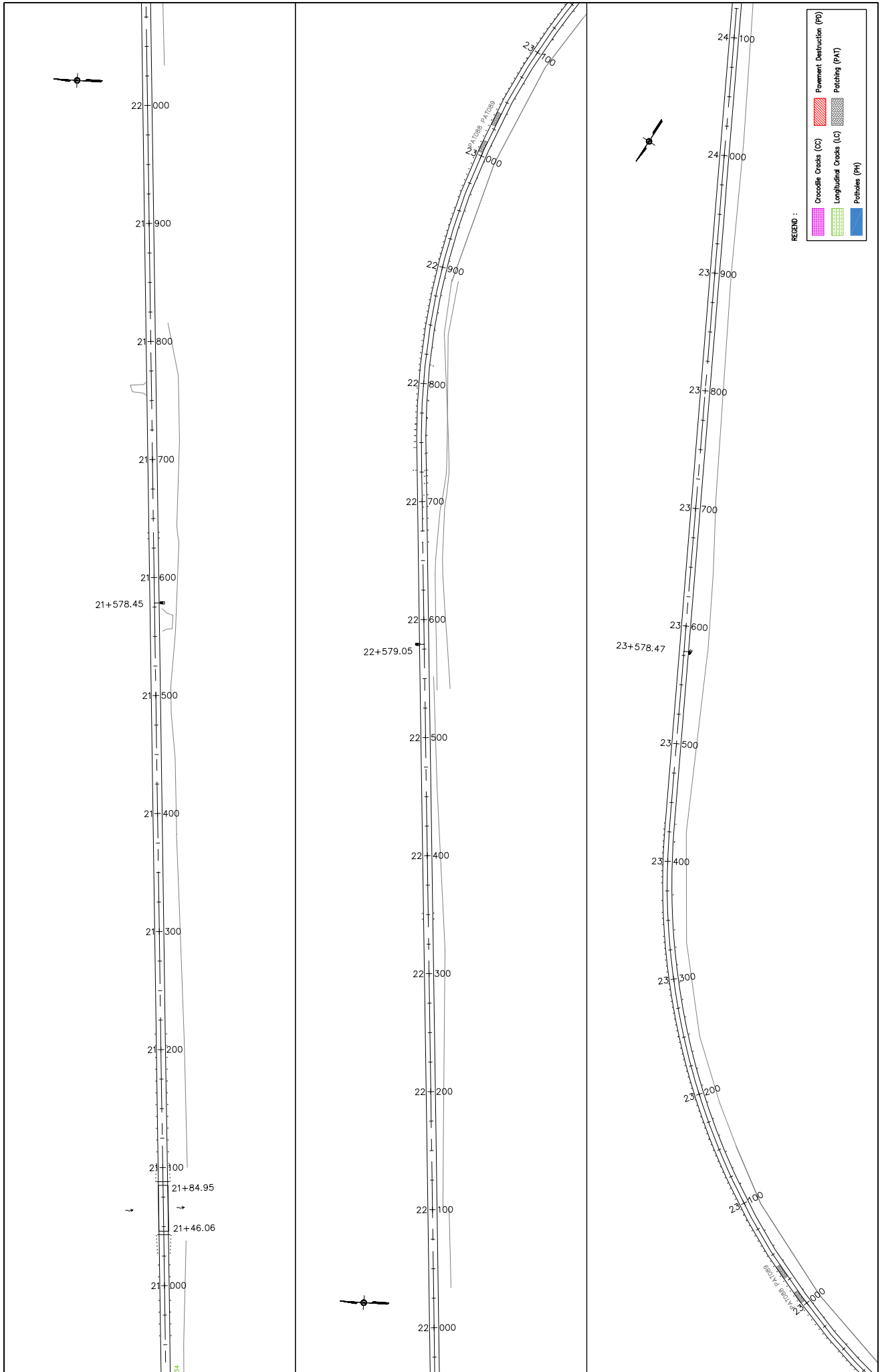

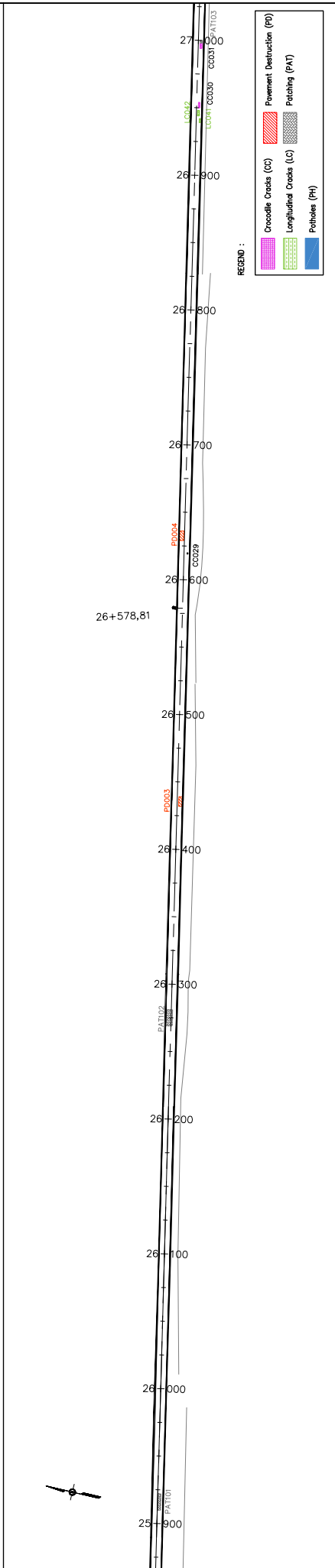
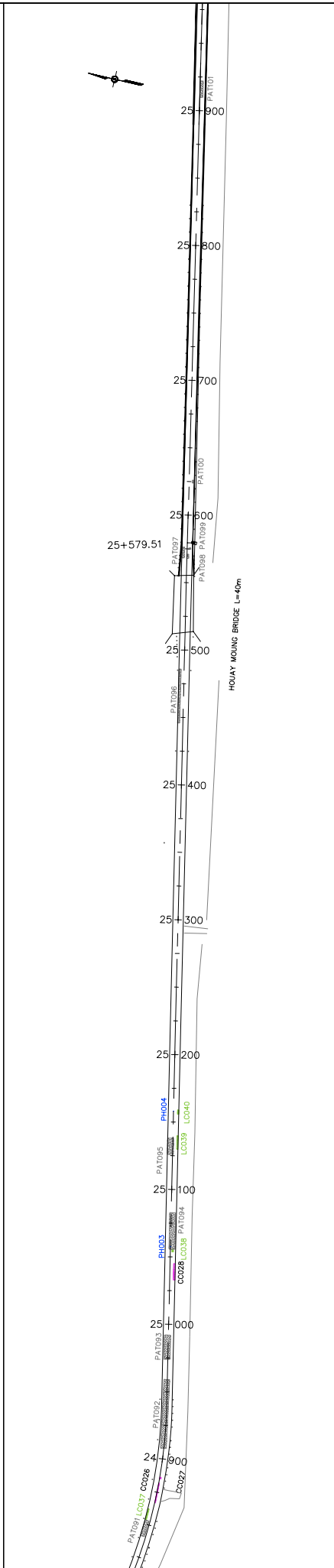
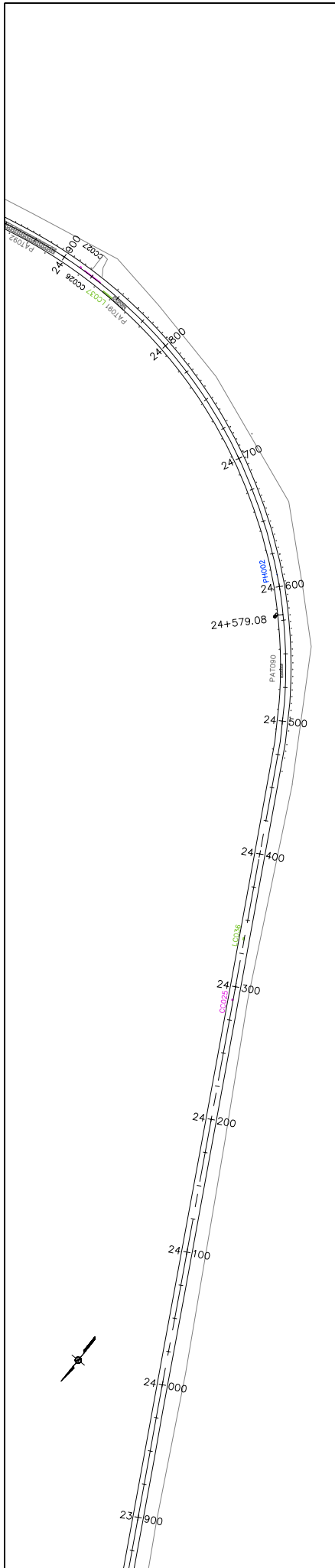

REGENE :

	Crocodile Croads (CC)		Pavement Destruction (PD)
	Longitudinal Croads (LC)		Patching (PAT)
	Potholes (PH)		

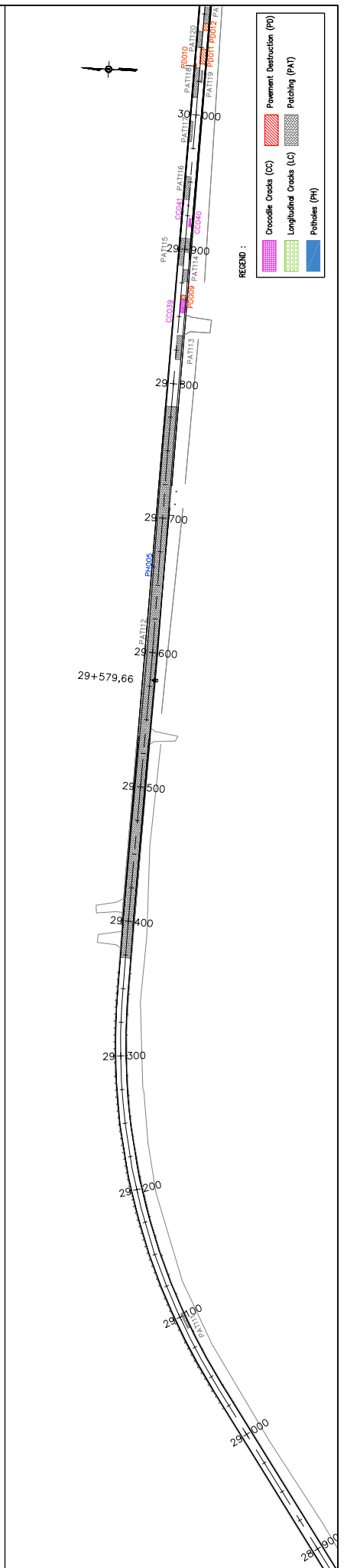
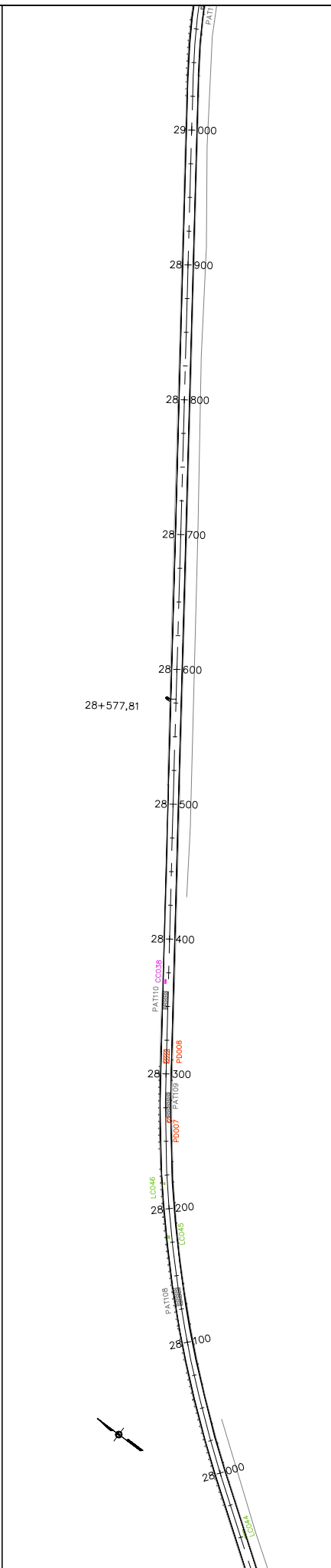
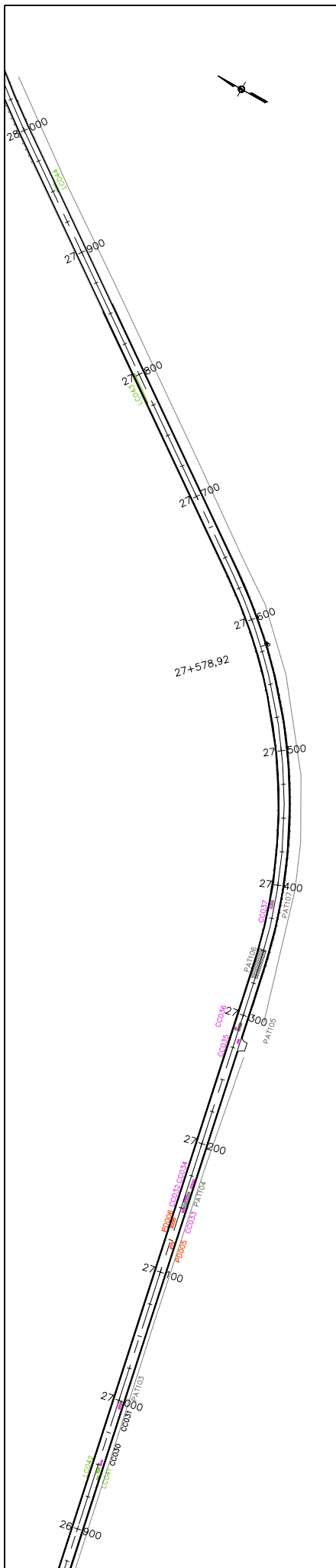

LEGEND :

	Cruciform Crosses (CC)		Pavement Destruction (PD)
	Longitudinal Crosses (LC)		Patching (PAT)
	Poles (PH)		



REGENO :

	Crocodile Cracks (CC)
	Longitudinal Cracks (LC)
	Potholes (PH)
	Crocodile Destruction (CD)
	Patching (PAT)

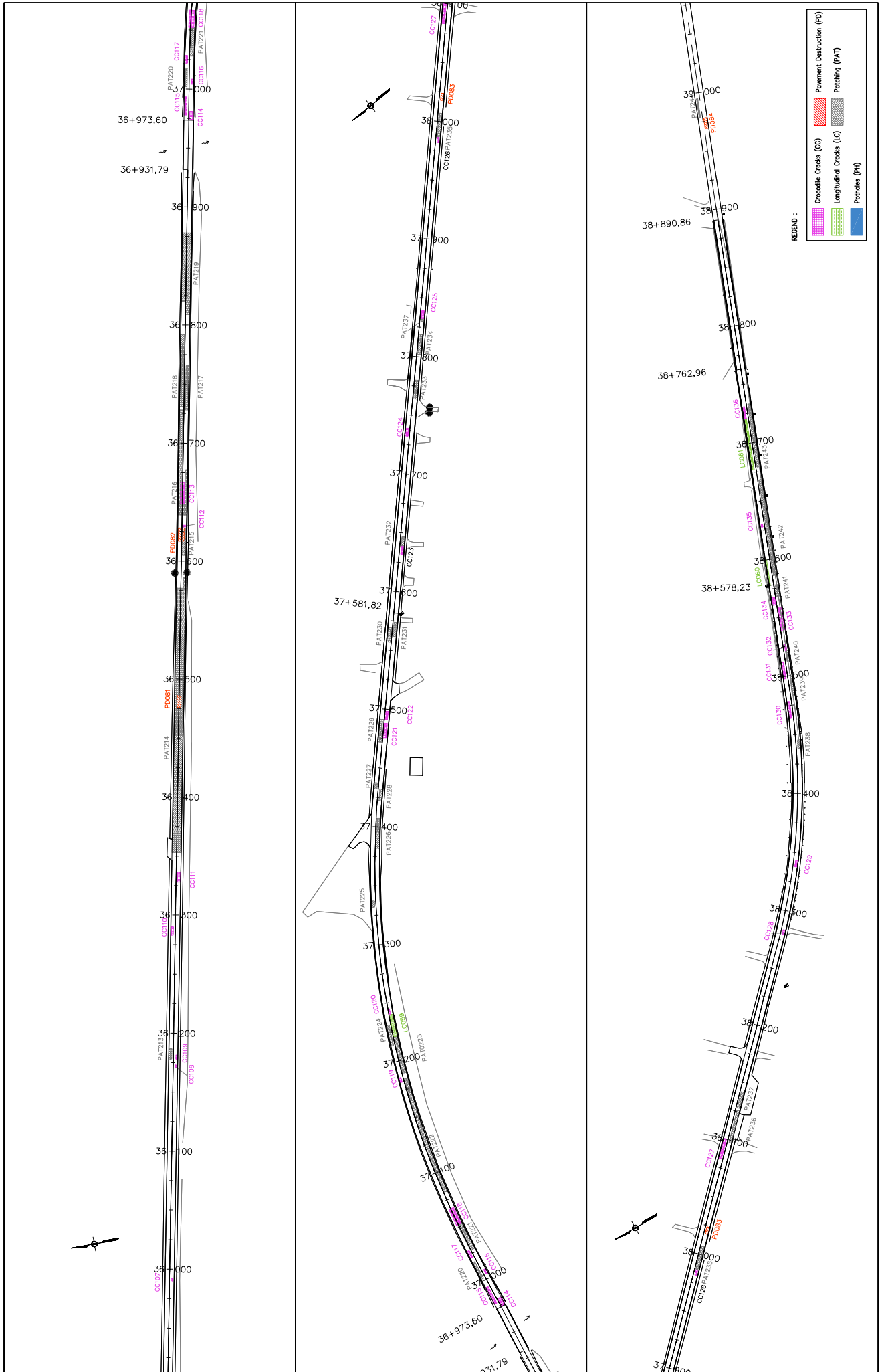

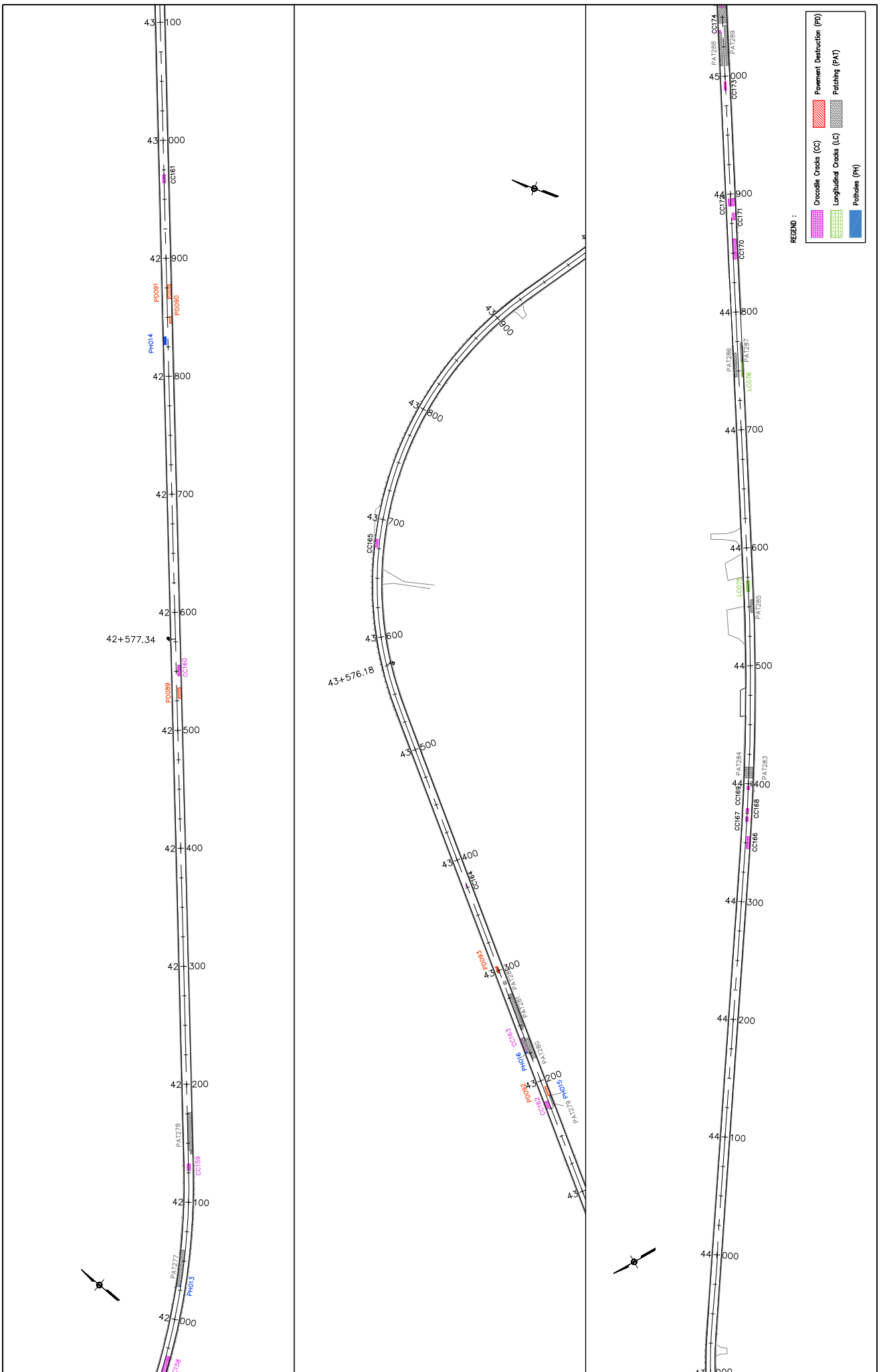

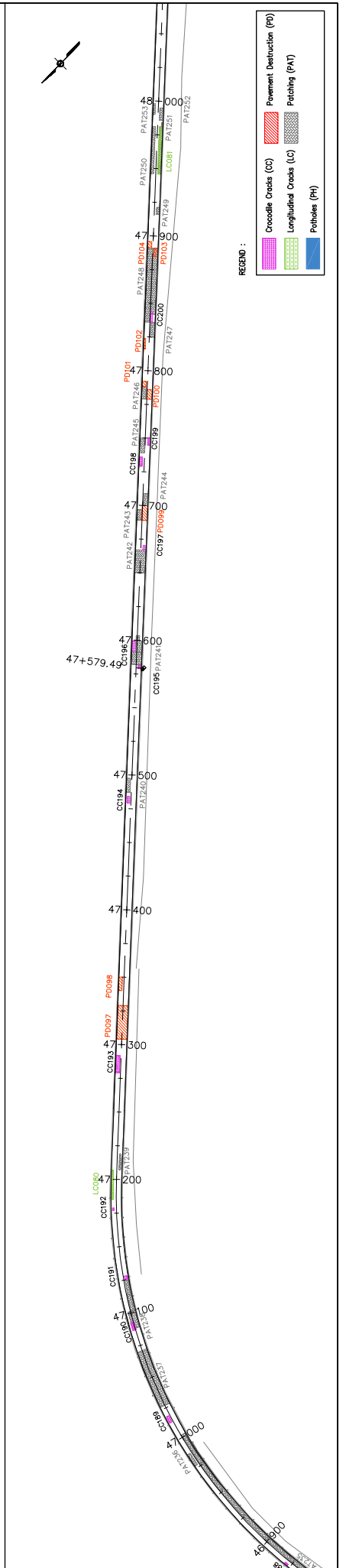
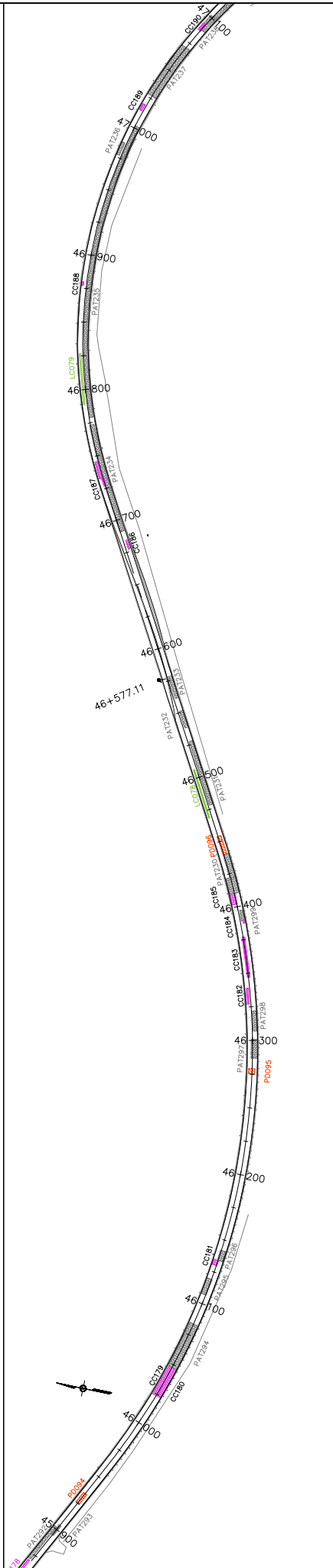
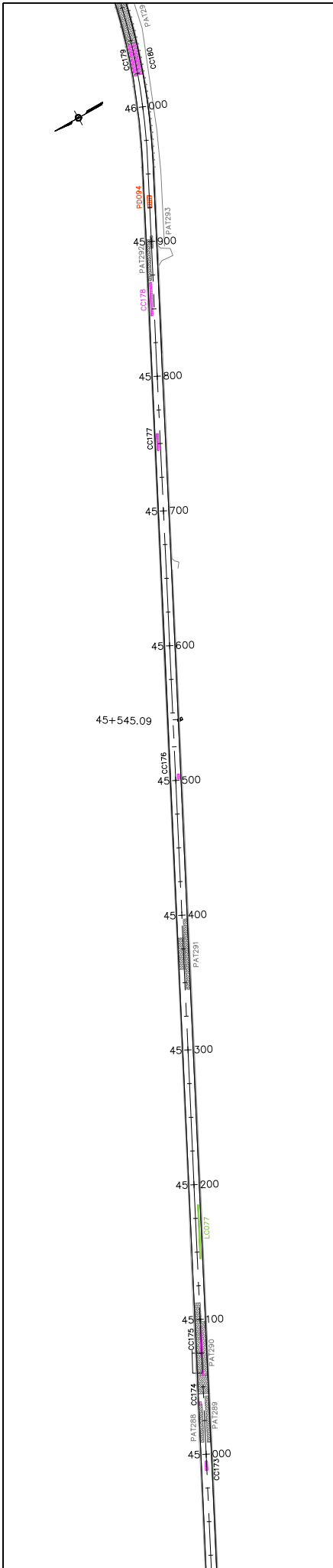

LEGEND :

	Crcodile Croads (CC)		Pavement Destruction (PD)
	Longitudinal Croads (LC)		Patching (PAT)
	Potholes (PH)		

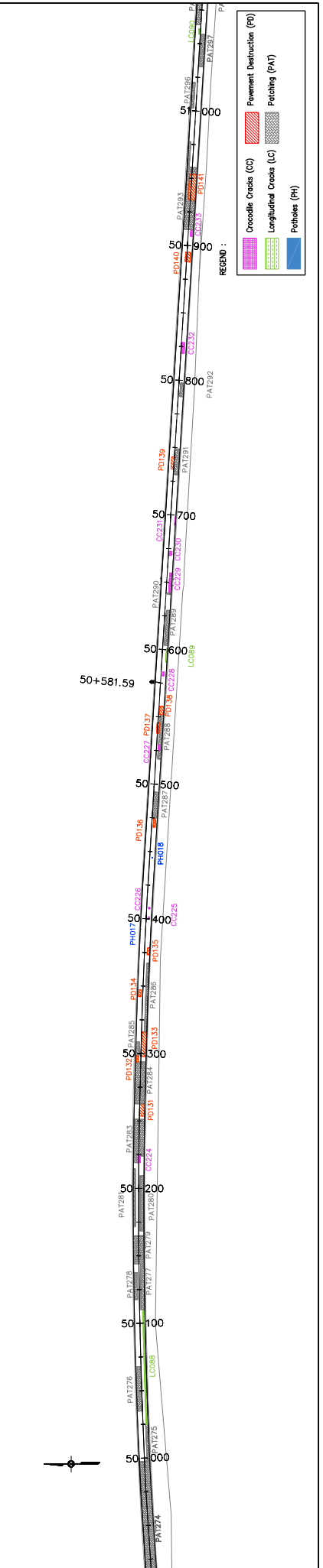
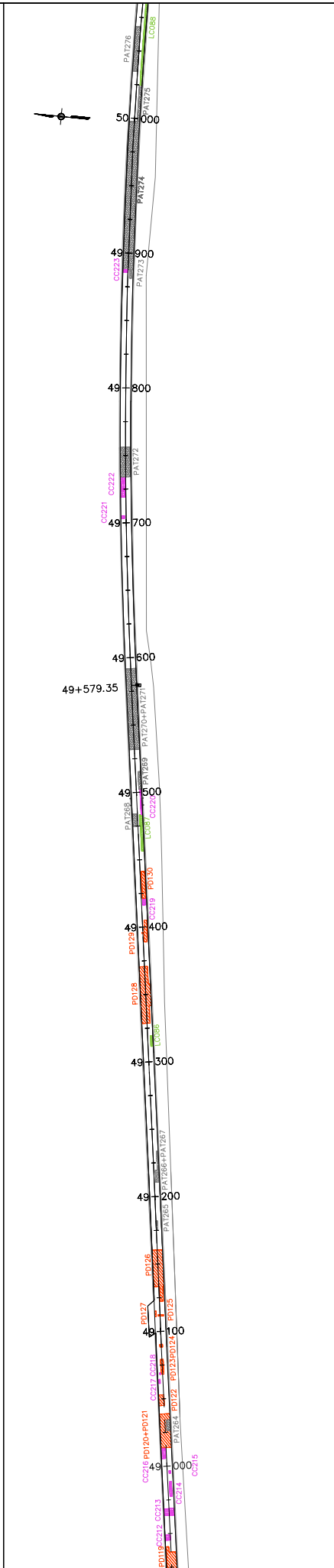
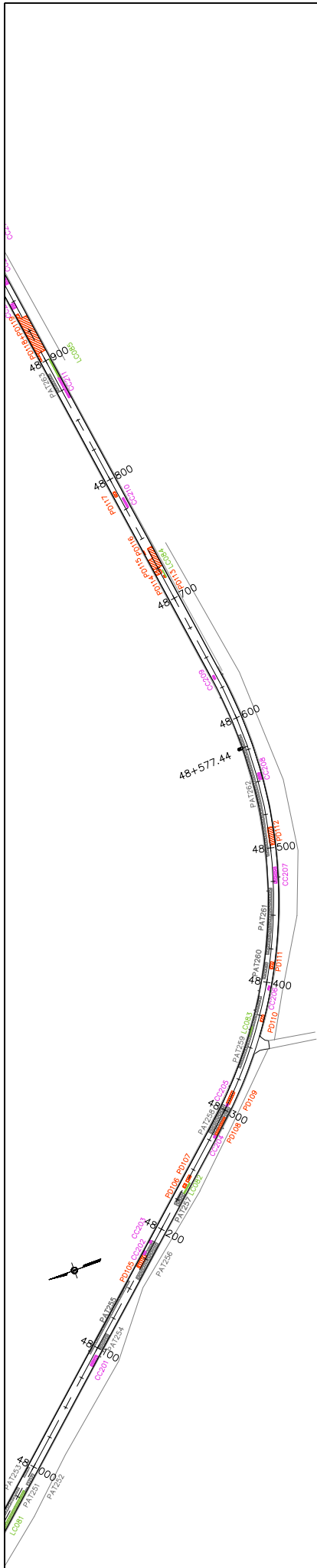

LEGEND :

	Crocodile Crosses (CC)		Pavement Destruction (PD)
	Longitudinal Crosses (LC)		Patching (PAT)
	Potholes (PH)		

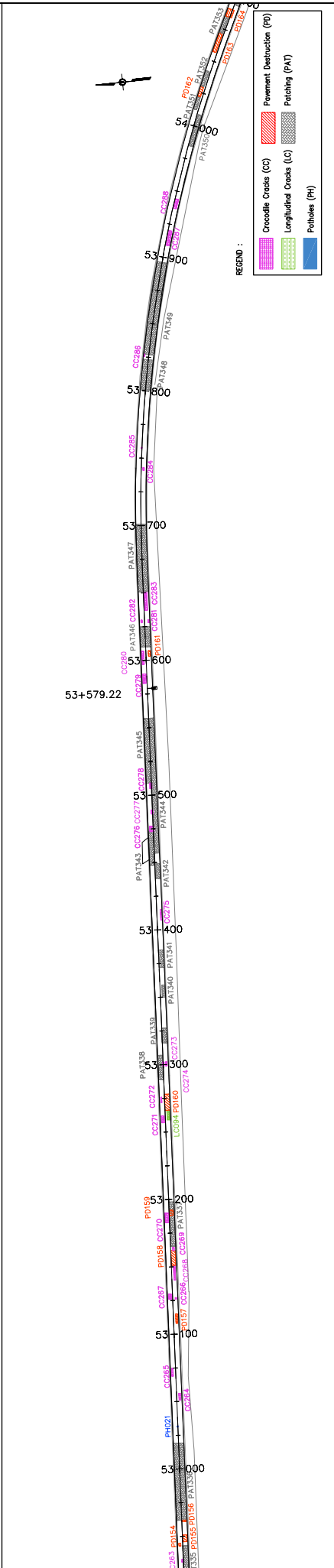
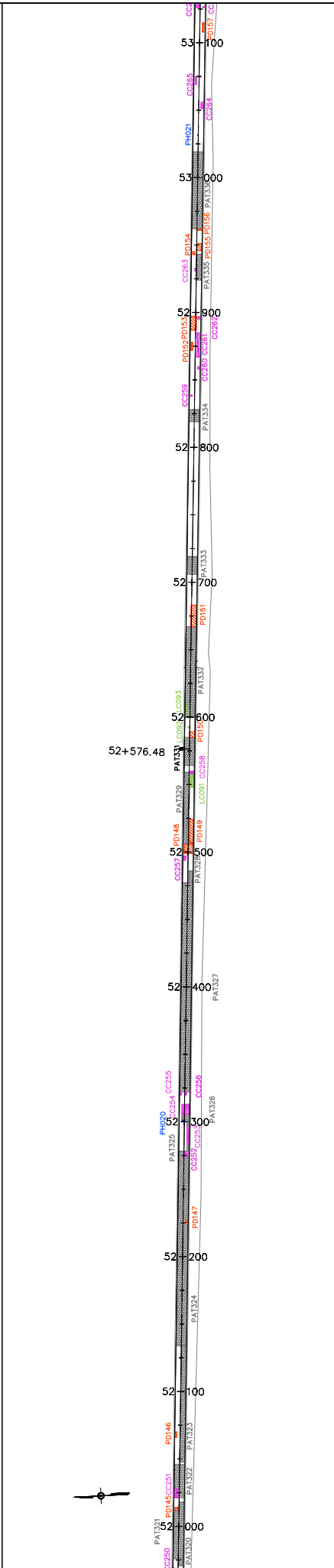
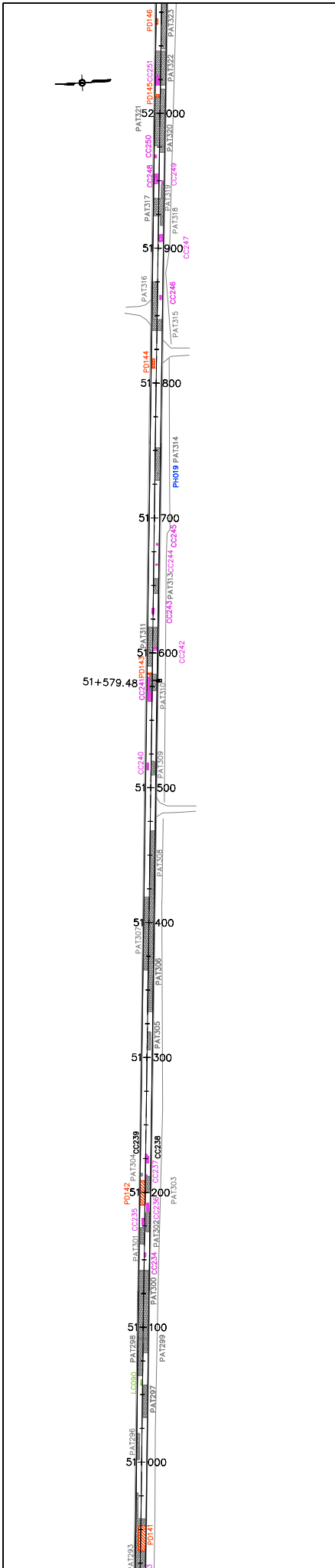

LEGEND :

- Crocodile Cords (CC) [Pattern: diagonal lines]
- Longitudinal Cords (LC) [Pattern: vertical lines]
- Potholes (PH) [Pattern: blue rectangle]
- Pavement Destruction (PD) [Pattern: red diagonal lines]
- Patching (PAT) [Pattern: cross-hatch]

