

Stationing	Track	Structure	Height (m)	Notes
17+500	1	Embankment	1.50	
17+500	2	Embankment	1.50	
17+500	3	Embankment	1.50	
17+500	4	Embankment	1.50	
17+500	5	Embankment	1.50	
17+500	6	Embankment	1.50	
17+500	7	Embankment	1.50	
17+500	8	Embankment	1.50	
17+500	9	Embankment	1.50	
17+500	10	Embankment	1.50	
17+500	11	Embankment	1.50	
17+500	12	Embankment	1.50	
17+500	13	Embankment	1.50	
17+500	14	Embankment	1.50	
17+500	15	Embankment	1.50	
17+500	16	Embankment	1.50	
17+500	17	Embankment	1.50	
17+500	18	Embankment	1.50	
17+500	19	Embankment	1.50	
17+500	20	Embankment	1.50	
17+500	21	Embankment	1.50	
17+500	22	Embankment	1.50	
17+500	23	Embankment	1.50	
17+500	24	Embankment	1.50	
17+500	25	Embankment	1.50	
17+500	26	Embankment	1.50	
17+500	27	Embankment	1.50	
17+500	28	Embankment	1.50	
17+500	29	Embankment	1.50	
17+500	30	Embankment	1.50	
17+500	31	Embankment	1.50	
17+500	32	Embankment	1.50	
17+500	33	Embankment	1.50	
17+500	34	Embankment	1.50	
17+500	35	Embankment	1.50	
17+500	36	Embankment	1.50	
17+500	37	Embankment	1.50	
17+500	38	Embankment	1.50	
17+500	39	Embankment	1.50	
17+500	40	Embankment	1.50	
17+500	41	Embankment	1.50	
17+500	42	Embankment	1.50	
17+500	43	Embankment	1.50	
17+500	44	Embankment	1.50	
17+500	45	Embankment	1.50	
17+500	46	Embankment	1.50	
17+500	47	Embankment	1.50	
17+500	48	Embankment	1.50	
17+500	49	Embankment	1.50	
17+500	50	Embankment	1.50	
17+500	51	Embankment	1.50	
17+500	52	Embankment	1.50	
17+500	53	Embankment	1.50	
17+500	54	Embankment	1.50	
17+500	55	Embankment	1.50	
17+500	56	Embankment	1.50	
17+500	57	Embankment	1.50	
17+500	58	Embankment	1.50	
17+500	59	Embankment	1.50	
17+500	60	Embankment	1.50	
17+500	61	Embankment	1.50	
17+500	62	Embankment	1.50	
17+500	63	Embankment	1.50	
17+500	64	Embankment	1.50	
17+500	65	Embankment	1.50	
17+500	66	Embankment	1.50	
17+500	67	Embankment	1.50	
17+500	68	Embankment	1.50	
17+500	69	Embankment	1.50	
17+500	70	Embankment	1.50	
17+500	71	Embankment	1.50	
17+500	72	Embankment	1.50	
17+500	73	Embankment	1.50	
17+500	74	Embankment	1.50	
17+500	75	Embankment	1.50	
17+500	76	Embankment	1.50	
17+500	77	Embankment	1.50	
17+500	78	Embankment	1.50	
17+500	79	Embankment	1.50	
17+500	80	Embankment	1.50	
17+500	81	Embankment	1.50	
17+500	82	Embankment	1.50	
17+500	83	Embankment	1.50	
17+500	84	Embankment	1.50	
17+500	85	Embankment	1.50	
17+500	86	Embankment	1.50	
17+500	87	Embankment	1.50	
17+500	88	Embankment	1.50	
17+500	89	Embankment	1.50	
17+500	90	Embankment	1.50	
17+500	91	Embankment	1.50	
17+500	92	Embankment	1.50	
17+500	93	Embankment	1.50	
17+500	94	Embankment	1.50	
17+500	95	Embankment	1.50	
17+500	96	Embankment	1.50	
17+500	97	Embankment	1.50	
17+500	98	Embankment	1.50	
17+500	99	Embankment	1.50	
17+500	100	Embankment	1.50	

THE PREPARATORY SURVEY
 OF
LACHU HAUSEN ROBOT CONSTRUCTION

JAPAN INTERNATIONAL COOPERATION AGENCY (JICA)
 Joint Venture of

SCALE 1:4000
TITLE
Plan and Profile

OF

Joint Ventures of

1:4000

Station	Profile	Height	Notes
70	8700.00	0.11	3.34
71	8700.00	0.12	3.44
72	8700.00	0.10	3.54
73	8700.00	0.08	3.64
74	8700.00	0.06	3.74
75	8700.00	0.04	3.84
76	8700.00	0.02	3.94
77	8700.00	0.00	4.04
78	8700.00	0.02	4.14
79	8700.00	0.04	4.24
80	8700.00	0.06	4.34
81	8700.00	0.08	4.44
82	8700.00	0.10	4.54
83	8700.00	0.12	4.64
84	8700.00	0.14	4.74
85	8700.00	0.16	4.84
86	8700.00	0.18	4.94
87	8700.00	0.20	5.04
88	8700.00	0.22	5.14
89	8700.00	0.24	5.24
90	8700.00	0.26	5.34
91	8700.00	0.28	5.44
92	8700.00	0.30	5.54
93	8700.00	0.32	5.64
94	8700.00	0.34	5.74
95	8700.00	0.36	5.84
96	8700.00	0.38	5.94
97	8700.00	0.40	6.04
98	8700.00	0.42	6.14
99	8700.00	0.44	6.24
100	8700.00	0.46	6.34
101	8700.00	0.48	6.44
102	8700.00	0.50	6.54
103	8700.00	0.52	6.64
104	8700.00	0.54	6.74
105	8700.00	0.56	6.84
106	8700.00	0.58	6.94
107	8700.00	0.60	7.04
108	8700.00	0.62	7.14
109	8700.00	0.64	7.24
110	8700.00	0.66	7.34
111	8700.00	0.68	7.44
112	8700.00	0.70	7.54
113	8700.00	0.72	7.64
114	8700.00	0.74	7.74
115	8700.00	0.76	7.84
116	8700.00	0.78	7.94
117	8700.00	0.80	8.04
118	8700.00	0.82	8.14
119	8700.00	0.84	8.24
120	8700.00	0.86	8.34
121	8700.00	0.88	8.44
122	8700.00	0.90	8.54
123	8700.00	0.92	8.64
124	8700.00	0.94	8.74
125	8700.00	0.96	8.84
126	8700.00	0.98	8.94
127	8700.00	1.00	9.04
128	8700.00	1.02	9.14
129	8700.00	1.04	9.24
130	8700.00	1.06	9.34
131	8700.00	1.08	9.44
132	8700.00	1.10	9.54
133	8700.00	1.12	9.64
134	8700.00	1.14	9.74
135	8700.00	1.16	9.84
136	8700.00	1.18	9.94
137	8700.00	1.20	10.04
138	8700.00	1.22	10.14
139	8700.00	1.24	10.24
140	8700.00	1.26	10.34
141	8700.00	1.28	10.44
142	8700.00	1.30	10.54
143	8700.00	1.32	10.64
144	8700.00	1.34	10.74
145	8700.00	1.36	10.84
146	8700.00	1.38	10.94
147	8700.00	1.40	11.04
148	8700.00	1.42	11.14
149	8700.00	1.44	11.24
150	8700.00	1.46	11.34
151	8700.00	1.48	11.44
152	8700.00	1.50	11.54
153	8700.00	1.52	11.64
154	8700.00	1.54	11.74
155	8700.00	1.56	11.84
156	8700.00	1.58	11.94
157	8700.00	1.60	12.04
158	8700.00	1.62	12.14
159	8700.00	1.64	12.24
160	8700.00	1.66	12.34
161	8700.00	1.68	12.44
162	8700.00	1.70	12.54
163	8700.00	1.72	12.64
164	8700.00	1.74	12.74
165	8700.00	1.76	12.84
166	8700.00	1.78	12.94
167	8700.00	1.80	13.04
168	8700.00	1.82	13.14
169	8700.00	1.84	13.24
170	8700.00	1.86	13.34
171	8700.00	1.88	13.44
172	8700.00	1.90	13.54
173	8700.00	1.92	13.64
174	8700.00	1.94	13.74
175	8700.00	1.96	13.84
176	8700.00	1.98	13.94
177	8700.00	2.00	14.04
178	8700.00	2.02	14.14
179	8700.00	2.04	14.24
180	8700.00	2.06	14.34
181	8700.00	2.08	14.44
182	8700.00	2.10	14.54
183	8700.00	2.12	14.64
184	8700.00	2.14	14.74
185	8700.00	2.16	14.84
186	8700.00	2.18	14.94
187	8700.00	2.20	15.04
188	8700.00	2.22	15.14
189	8700.00	2.24	15.24
190	8700.00	2.26	15.34
191	8700.00	2.28	15.44
192	8700.00	2.30	15.54
193	8700.00	2.32	15.64
194	8700.00	2.34	15.74
195	8700.00	2.36	15.84
196	8700.00	2.38	15.94
197	8700.00	2.40	16.04
198	8700.00	2.42	16.14
199	8700.00	2.44	16.24
200	8700.00	2.46	16.34
201	8700.00	2.48	16.44
202	8700.00	2.50	16.54
203	8700.00	2.52	16.64
204	8700.00	2.54	16.74
205	8700.00	2.56	16.84
206	8700.00	2.58	16.94
207	8700.00	2.60	17.04
208	8700.00	2.62	17.14
209	8700.00	2.64	17.24
210	8700.00	2.66	17.34
211	8700.00	2.68	17.44
212	8700.00	2.70	17.54
213	8700.00	2.72	17.64
214	8700.00	2.74	17.74
215	8700.00	2.76	17.84
216	8700.00	2.78	17.94
217	8700.00	2.80	18.04
218	8700.00	2.82	18.14
219	8700.00	2.84	18.24
220	8700.00	2.86	18.34
221	8700.00	2.88	18.44
222	8700.00	2.90	18.54
223	8700.00	2.92	18.64
224	8700.00	2.94	18.74
225	8700.00	2.96	18.84
226	8700.00	2.98	18.94
227	8700.00	3.00	19.04
228	8700.00	3.02	19.14
229	8700.00	3.04	19.24
230	8700.00	3.06	19.34
231	8700.00	3.08	19.44
232	8700.00	3.10	19.54
233	8700.00	3.12	19.64
234	8700.00	3.14	19.74
235	8700.00	3.16	19.84
236	8700.00	3.18	19.94
237	8700.00	3.20	20.04
238	8700.00	3.22	20.14
239	8700.00	3.24	20.24
240	8700.00	3.26	20.34
241	8700.00	3.28	20.44
242	8700.00	3.30	20.54
243	8700.00	3.32	20.64
244	8700.00	3.34	20.74
245	8700.00	3.36	20.84
246	8700.00	3.38	20.94
247	8700.00	3.40	21.04
248	8700.00	3.42	21.14
249	8700.00	3.44	21.24
250	8700.00	3.46	21.34
251	8700.00	3.48	21.44
252	8700.00	3.50	21.54
253	8700.00	3.52	21.64
254	8700.00	3.54	21.74
255	8700.00	3.56	21.84
256	8700.00	3.58	21.94
257	8700.00	3.60	22.04
258	8700.00	3.62	22.14
259	8700.00	3.64	22.24
260	8700.00	3.66	22.34
261	8700.00	3.68	22.44
262	8700.00	3.70	22.54
263	8700.00	3.72	22.64
264	8700.00	3.74	22.74
265	8700.00	3.76	22.84
266	8700.00	3.78	22.94
267	8700.00	3.80	23.04
268	8700.00	3.82	23.14
269	8700.00	3.84	23.24
270	8700.00	3.86	23.34
271	8700.00	3.88	23.44
272	8700.00	3.90	23.54
273	8700.00	3.92	23.64
274	8700.00	3.94	23.74
275	8700.00	3.96	23.84
276	8700.00	3.98	23.94
277	8700.00	4.00	24.04
278	8700.00	4.02	24.14
279	8700.00	4.04	24.24
280	8700.00	4.06	24.34
281	8700.00	4.08	24.44
282	8700.00	4.10	24.54
283	8700.00	4.12	24.64
284	8700.00	4.14	24.74
285	8700.00	4.16	24.84
286	8700.00	4.18	24.94
287	8700.00	4.20	25.04
288	8700.00	4.22	25.14
289	8700.00	4.24	25.24
290	8700.00	4.26	25.34
291	8700.00	4.28	25.44
292	8700.00	4.30	25.54
293	8700.00	4.32	25.64
294	8700.00	4.34	25.74
295	8700.00	4.36	25.84
296	8700.00	4.38	25.94
297	8700.00	4.40	26.04
298	8700.00	4.42	26.14
299	8700.00	4.44	26.24
300	8700.00	4.46	26.34
301	8700.00	4.48	26.44
302	8700.00	4.50	26.54
303	8700.00	4.52	26.64
304	8700.00	4.54	26.74
305	8700.00	4.56	26.84
306	8700.00	4.58	26.94
307	8700.00	4.60	27.04
308	8700.00	4.62	27.14
309	8700.00	4.64	27.24
310	8700.00	4.66	27.34
311	8700.00	4.68	27.44
312	8700.00	4.70	27.54
313	8700.00	4.72	27.64
314	8700.00	4.74	27.74
315	8700.00	4.76	27.84
316	8700.00	4.78	27.94
317	8700.00	4.80	28.04
318	8700.00	4.82	28.14
319	8700.00	4.84	28.24
320	8700.00	4.86	28.34
321	8700.00	4.88	28.44
322	8700.00	4.90	28.54
323	8700.00	4.92	28.64
324	8700.00	4.94	28.74
325	8700.00	4.96	28.84
326	8700.00	4.98	28.94
327	8700.00	5.00	29.04
328	8700.00	5.02	29.14
329	8700.00	5.04	29.24
330	8700.00	5.06	29.34
331	8700.00	5.08	29.44
332	8700.00	5.10	29.54
333	8700.00	5.12	29.64
334	8700.00	5.14	29.74
335	8700.00	5.16	29.84
336	8700.00	5.18	29.94
337	8700.00	5.20	30.04
338	8700.00	5.22	30.14
339	8700.00	5.24	30.24
340	8700.00	5.26	30.34
341	8700.00		

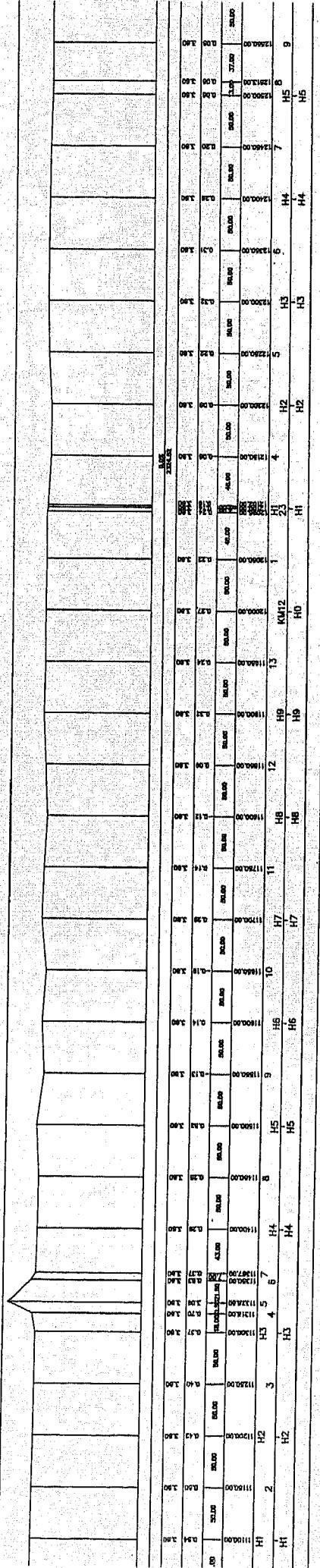
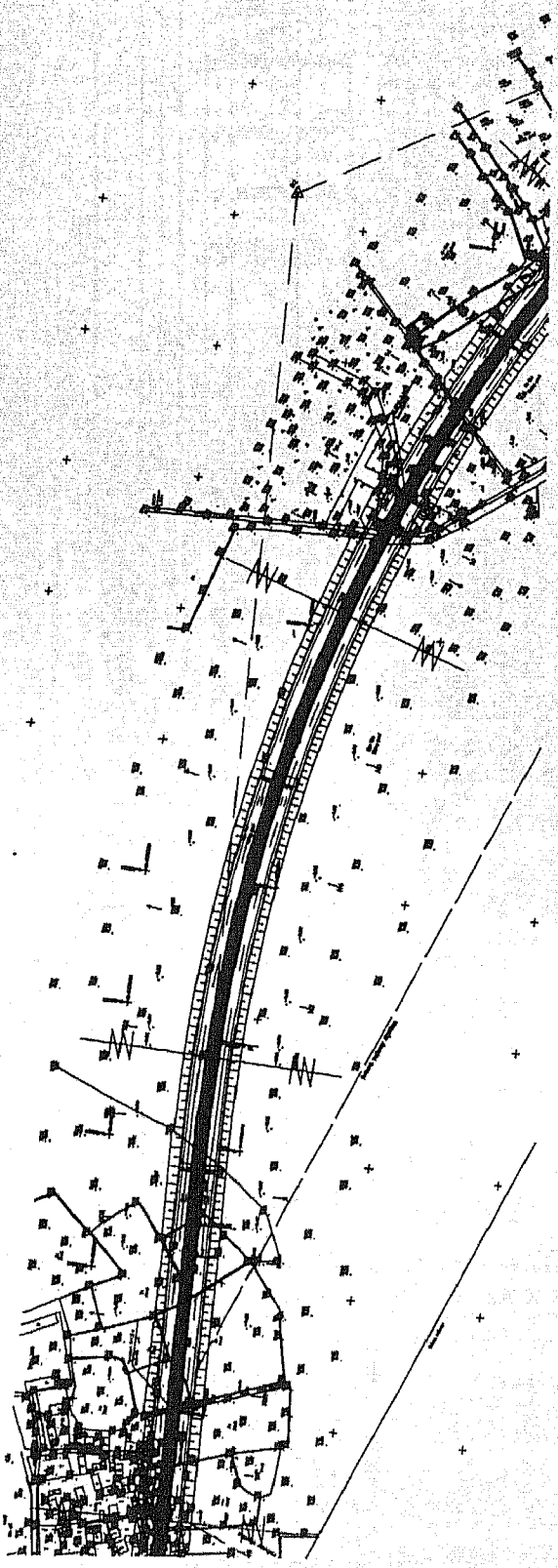

STATION	PROPOSED GRADE (M)	EXISTING GRADE (M)	VERTICAL CURVE DATA	MARKING
0+00	11100.00	11100.00		H1
0+20	11200.00	11200.00		H2
0+40	11250.00	11250.00		H3
0+70	11300.00	11300.00		H4
1+00	11400.00	11400.00		H4
1+20	11500.00	11500.00		H5
1+50	11600.00	11600.00		H5
1+80	11700.00	11700.00		H7
2+10	11750.00	11750.00		H8
2+40	11800.00	11800.00		H8
2+70	11900.00	11900.00		H9
3+00	11900.00	11900.00		H9
3+30	12000.00	12000.00		H0
3+60	12100.00	12100.00		H1
3+90	12200.00	12200.00		H2
4+20	12300.00	12300.00		H3
4+50	12400.00	12400.00		H4
4+80	12500.00	12500.00		H5
5+10	12600.00	12600.00		H5
5+40	12700.00	12700.00		H7
5+70	12800.00	12800.00		H8
6+00	12900.00	12900.00		H9
6+30	13000.00	13000.00		H0
6+60	13100.00	13100.00		H1
6+90	13200.00	13200.00		H2
7+20	13300.00	13300.00		H3
7+50	13400.00	13400.00		H4
7+80	13500.00	13500.00		H5
8+10	13600.00	13600.00		H5
8+40	13700.00	13700.00		H7
8+70	13800.00	13800.00		H8
9+00	13900.00	13900.00		H9
9+30	14000.00	14000.00		H0
9+60	14100.00	14100.00		H1
9+90	14200.00	14200.00		H2
10+20	14300.00	14300.00		H3
10+50	14400.00	14400.00		H4
10+80	14500.00	14500.00		H5
11+10	14600.00	14600.00		H5
11+40	14700.00	14700.00		H7
11+70	14800.00	14800.00		H8
12+00	14900.00	14900.00		H9
12+30	15000.00	15000.00		H0
12+60	15100.00	15100.00		H1
12+90	15200.00	15200.00		H2
13+20	15300.00	15300.00		H3
13+50	15400.00	15400.00		H4
13+80	15500.00	15500.00		H5
14+10	15600.00	15600.00		H5
14+40	15700.00	15700.00		H7
14+70	15800.00	15800.00		H8
15+00	15900.00	15900.00		H9
15+30	16000.00	16000.00		H0
15+60	16100.00	16100.00		H1
15+90	16200.00	16200.00		H2
16+20	16300.00	16300.00		H3
16+50	16400.00	16400.00		H4
16+80	16500.00	16500.00		H5
17+10	16600.00	16600.00		H5
17+40	16700.00	16700.00		H7
17+70	16800.00	16800.00		H8
18+00	16900.00	16900.00		H9
18+30	17000.00	17000.00		H0
18+60	17100.00	17100.00		H1
18+90	17200.00	17200.00		H2
19+20	17300.00	17300.00		H3
19+50	17400.00	17400.00		H4
19+80	17500.00	17500.00		H5
20+10	17600.00	17600.00		H5
20+40	17700.00	17700.00		H7
20+70	17800.00	17800.00		H8
21+00	17900.00	17900.00		H9
21+30	18000.00	18000.00		H0
21+60	18100.00	18100.00		H1
21+90	18200.00	18200.00		H2
22+20	18300.00	18300.00		H3
22+50	18400.00	18400.00		H4
22+80	18500.00	18500.00		H5
23+10	18600.00	18600.00		H5
23+40	18700.00	18700.00		H7
23+70	18800.00	18800.00		H8
24+00	18900.00	18900.00		H9
24+30	19000.00	19000.00		H0
24+60	19100.00	19100.00		H1
24+90	19200.00	19200.00		H2
25+20	19300.00	19300.00		H3
25+50	19400.00	19400.00		H4
25+80	19500.00	19500.00		H5
26+10	19600.00	19600.00		H5
26+40	19700.00	19700.00		H7
26+70	19800.00	19800.00		H8
27+00	19900.00	19900.00		H9
27+30	20000.00	20000.00		H0
27+60	20100.00	20100.00		H1
27+90	20200.00	20200.00		H2
28+20	20300.00	20300.00		H3
28+50	20400.00	20400.00		H4
28+80	20500.00	20500.00		H5
29+10	20600.00	20600.00		H5
29+40	20700.00	20700.00		H7
29+70	20800.00	20800.00		H8
30+00	20900.00	20900.00		H9
30+30	21000.00	21000.00		H0
30+60	21100.00	21100.00		H1
30+90	21200.00	21200.00		H2
31+20	21300.00	21300.00		H3
31+50	21400.00	21400.00		H4
31+80	21500.00	21500.00		H5
32+10	21600.00	21600.00		H5
32+40	21700.00	21700.00		H7
32+70	21800.00	21800.00		H8
33+00	21900.00	21900.00		H9
33+30	22000.00	22000.00		H0
33+60	22100.00	22100.00		H1
33+90	22200.00	22200.00		H2
34+20	22300.00	22300.00		H3
34+50	22400.00	22400.00		H4
34+80	22500.00	22500.00		H5
35+10	22600.00	22600.00		H5
35+40	22700.00	22700.00		H7
35+70	22800.00	22800.00		H8
36+00	22900.00	22900.00		H9
36+30	23000.00	23000.00		H0
36+60	23100.00	23100.00		H1
36+90	23200.00	23200.00		H2
37+20	23300.00	23300.00		H3
37+50	23400.00	23400.00		H4
37+80	23500.00	23500.00		H5
38+10	23600.00	23600.00		H5
38+40	23700.00	23700.00		H7
38+70	23800.00	23800.00		H8
39+00	23900.00	23900.00		H9
39+30	24000.00	24000.00		H0
39+60	24100.00	24100.00		H1
39+90	24200.00	24200.00		H2
40+20	24300.00	24300.00		H3
40+50	24400.00	24400.00		H4
40+80	24500.00	24500.00		H5
41+10	24600.00	24600.00		H5
41+40	24700.00	24700.00		H7
41+70	24800.00	24800.00		H8
42+00	24900.00	24900.00		H9
42+30	25000.00	25000.00		H0
42+60	25100.00	25100.00		H1
42+90	25200.00	25200.00		H2
43+20	25300.00	25300.00		H3
43+50	25400.00	25400.00		H4
43+80	25500.00	25500.00		H5
44+10	25600.00	25600.00		H5
44+40	25700.00	25700.00		H7
44+70	25800.00	25800.00		H8
45+00	25900.00	25900.00		H9
45+30	26000.00	26000.00		H0
45+60	26100.00	26100.00		H1
45+90	26200.00	26200.00		H2
46+20	26300.00	26300.00		H3
46+50	26400.00	26400.00		H4
46+80	26500.00	26500.00		H5
47+10	26600.00	26600.00		H5
47+40	26700.00	26700.00		H7
47+70	26800.00	26800.00		H8
48+00	26900.00	26900.00		H9
48+30	27000.00	27000.00		H0
48+60	27100.00	27100.00		H1
48+90	27200.00	27200.00		H2
49+20	27300.00	27300.00		H3
49+50	27400.00	27400.00		H4
49+80	27500.00	27500.00		H5
50+10	27600.00	27600.00		H5
50+40	27700.00	27700.00		H7
50+70	27800.00	27800.00		H8
51+00	27900.00	27900.00		H9
51+30	28000.00	28000.00		H0
51+60	28100.00	28100.00		H1
51+90	28200.00	28200.00		H2
52+20	28300.00	28300.00		H3
52+50	28400.00	28400.00		H4
52+80	28500.00	28500.00		H5
53+10	28600.00	28600.00		H5
53+40	28700.00	28700.00		H7
53+70	28800.00	28800.00		H8
54+00	28900.00	28900.00		H9
54+30	29000.00	29000.00		H0
54+60	29100.00	29100.00		H1
54+90	29200.00	29200.00		H2
55+20	29300.00	29300.00		H3
55+50	29400.00	29400.00		H4
55+80	29500.00	29500.00		H5
56+10	29600.00	29600.00		H5
56+40	29700.00	29700.00		H7
56+70	29800.00	29800.00		H8
57+00	29900.00	29900.00		H9
57+30	30000.00	30000.00		H0
57+60	30100.00	30100.00		H1
57+90	30200.00	30200.00		H2
58+20	30300.00	30300.00		H3
58+50	30400.00	30400.00		H4
58+80	30500.00	30500.00		H5
59+10	30600.00	30600.00		H5
59+40	30700.00	30700.00		H7
59+70	30800.00	30800.00		H8
60+00	30900.00	30900.00		H9
60+30	31000.00	31000.00		H0
60+60	31100.00	31100.00		H1
60+90	31200.00	31200.00		H2
61+20	31300.00	31300.00		H3
61+50	31400.00	31400.00		H4
61+80	31500.00	31500.00		H5
62+10	31600.00	31600.00		H5
62+40	31700.00	31700.00		H7
62+70	31800.00	31800.00		H8
63+00	31900.00	31900.00		H9
63+30	32000.00	32000.00		H0
63+60	32100.00	32100.00		H1
63+90	32200.00	32200.00		H2
64+20	32300.00	32300.00		H3
64+50	32400.00	32400.00		H4
64+80	32500.00	32500.00		H5
65+10	32600.00	32600.00		H5
65+40	32700.00	32700.00		H7
65+70	32800.00	32800.00		H8
66+00	32900.00	32900.00		H9
66+30	33000.00	33000.00		H0
66+60	33100.00	33100.00		H1
66+90	33200.00	33200.00		H2
67+20	33300.00	33300.00		H3
67+50	33400.00	33400.00		H4
67+80	33500.00	33500.00		H5
68+10	33600.00	33600.00		H5
68+40	33700.00	33700.00		H7
68+70	33800.00	33800.00		H8
69+00	33900.00	33900.00		H9
69+30	34000.00	34000.00		H0
69+60	34100.00	34100.00		H1
69+90	34200.00	34200.00		H2
70+20	34300.00	34300.00		H3
70+50	34400.00	34400.00		H4
70+80	34500.00	34500.00		H5
71+10	34600.00	3		

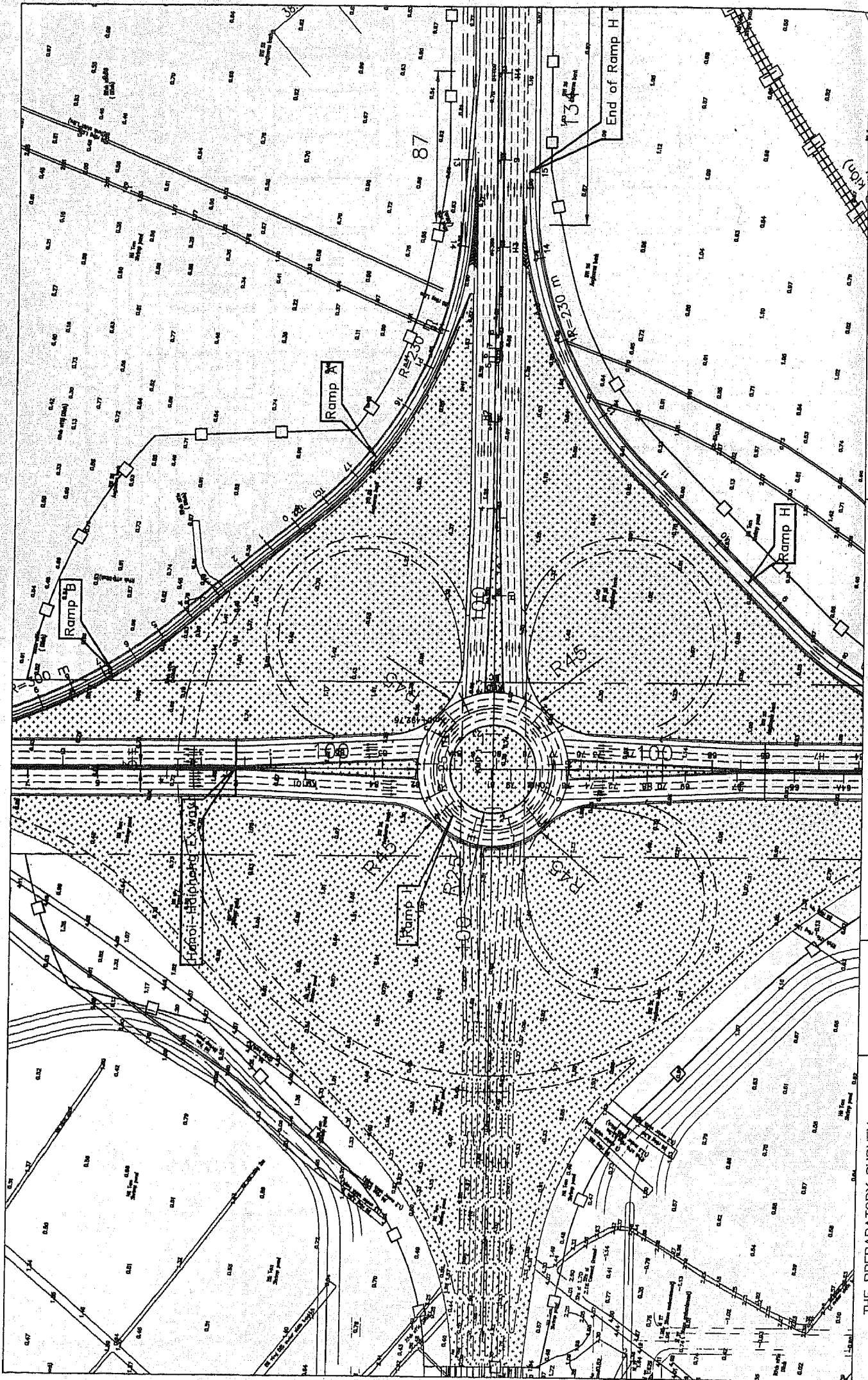

THE PREPARATORY SURVEY
OF

JAPAN INTERNATIONAL COOPERATION AGENCY (JICA)
Joint Venture of

TITLE

Ian Yu Intersection

SCALE 1:2000

TYPICAL CROSS SECTIONS (Stage Construction, Full 6-lane)

1st STAGE CONSTRUCTION, Bridge = 16m
 B_{lane} = 3.5m (4 LANES)

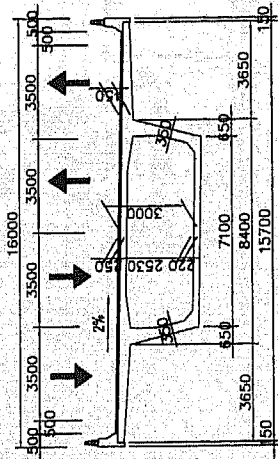

FULL SCALE CONSTRUCTION, Bridge = 28.5m
 B_{lane} = 3.5m (6 LANES)

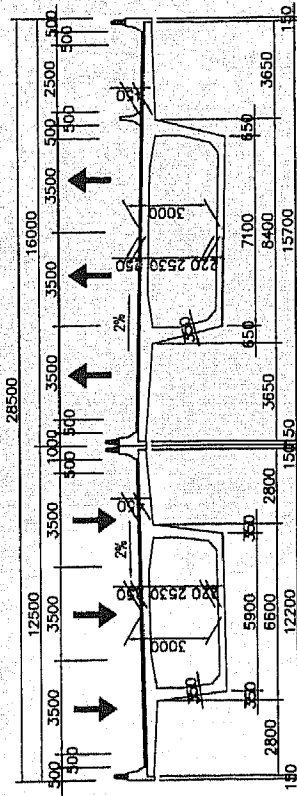

THE PREPARATORY SURVEY
 OF
 LACH HUYEN PORT CONSTRUCTION
 (ROAD AND BRIDGE PORTION)



JAPAN INTERNATIONAL COOPERATION AGENCY (JICA)
 Joint Venture of
 Nippon Koei Co., Ltd. and
 Japan Bridge & Structure Institute, Inc.

TITLE
 TYPICAL CROSS SECTIONS
 (Stage Construction, Full 6-lane)

SCALE
 1:200

No.
 B-01

mặt cắt A - A
cross section A - A
tỷ lệ: 1/400
scale: 1/400

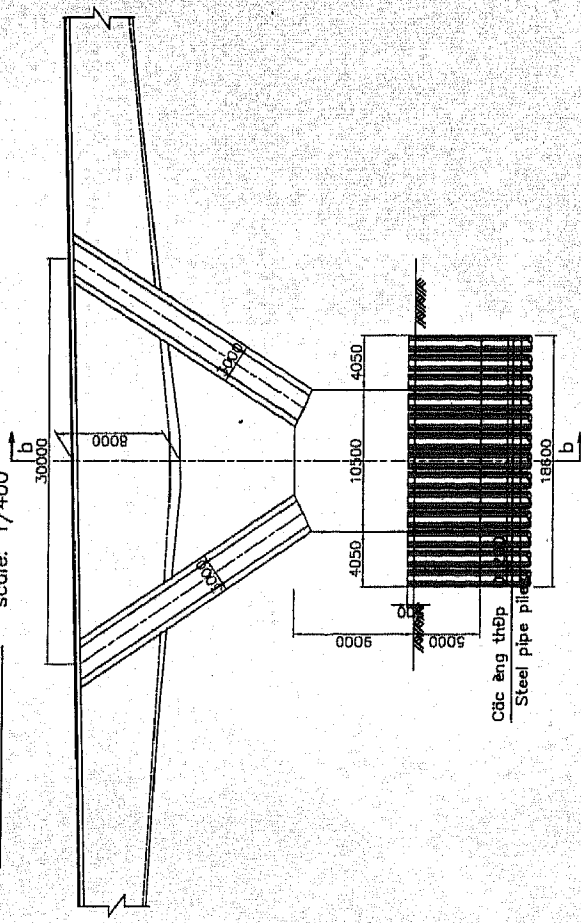

kỹ thuật chung trở cấu chính và approach bridge pier
general view of main bridge pier and approach bridge pier

mặt cắt B - B
cross section B - B
tỷ lệ: 1/400
scale: 1/400

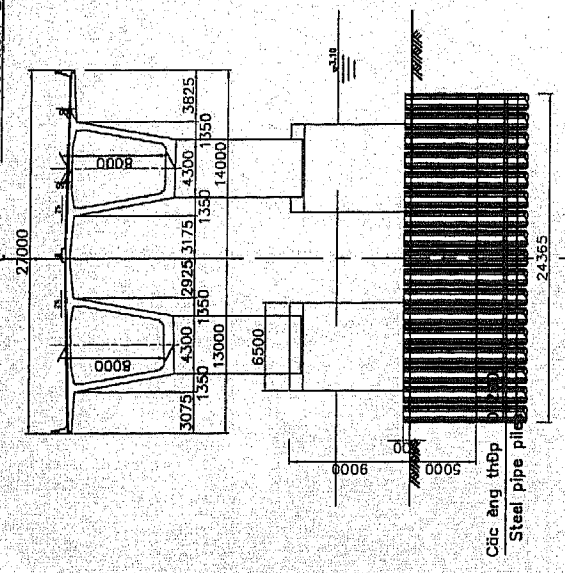

mặt cắt c - c
cross section c - c
tỷ lệ: 1/200
scale: 1/200

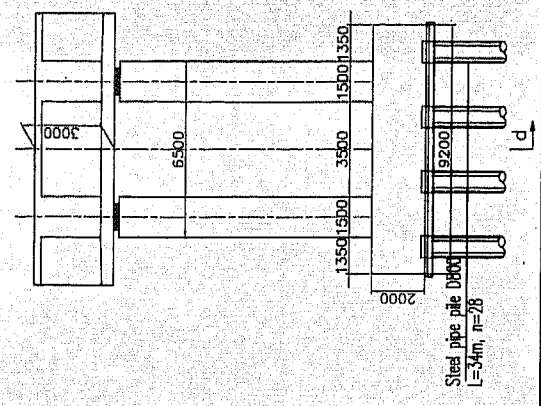

mặt cắt d - d
cross section d - d
tỷ lệ: 1/200
scale: 1/200

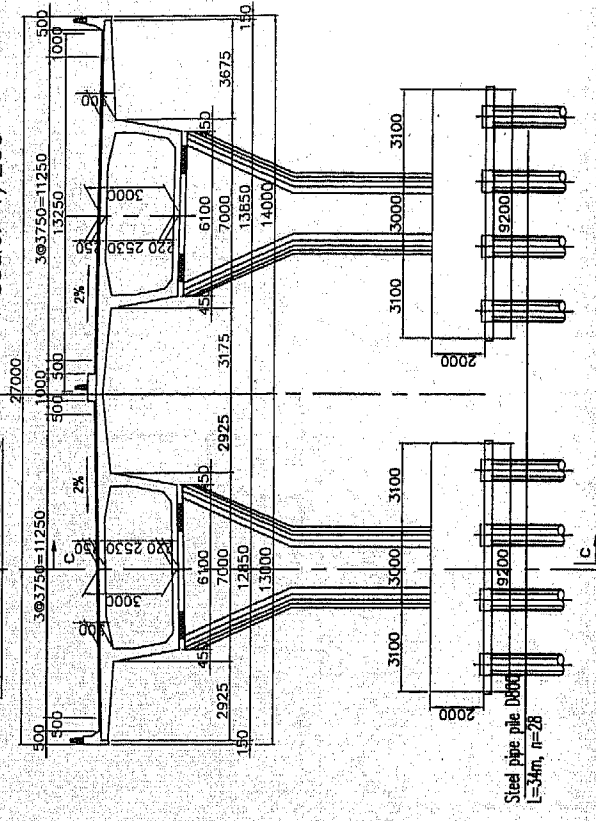

c?c b?tc thi cng mē — construction method of abutment

b?tc 1: thi cng c?c ?ng th?p DB00
 Stage 1: construction of steel pipe
 piles DB00

b?tc 2: ?mu ?Et hē m?ng
 THI C?NG B? T?NG T?O PH?NG + B? Mē
 Stage 2: Excavating soil
 construction blinding concrete + of abutment.

b?tc 3: thi cng b? teng th?n mē, t?ng mē + ho?n thi?n
 thi cng mē
 stage 3: construction of stem & head wall + completing
 abutment construction

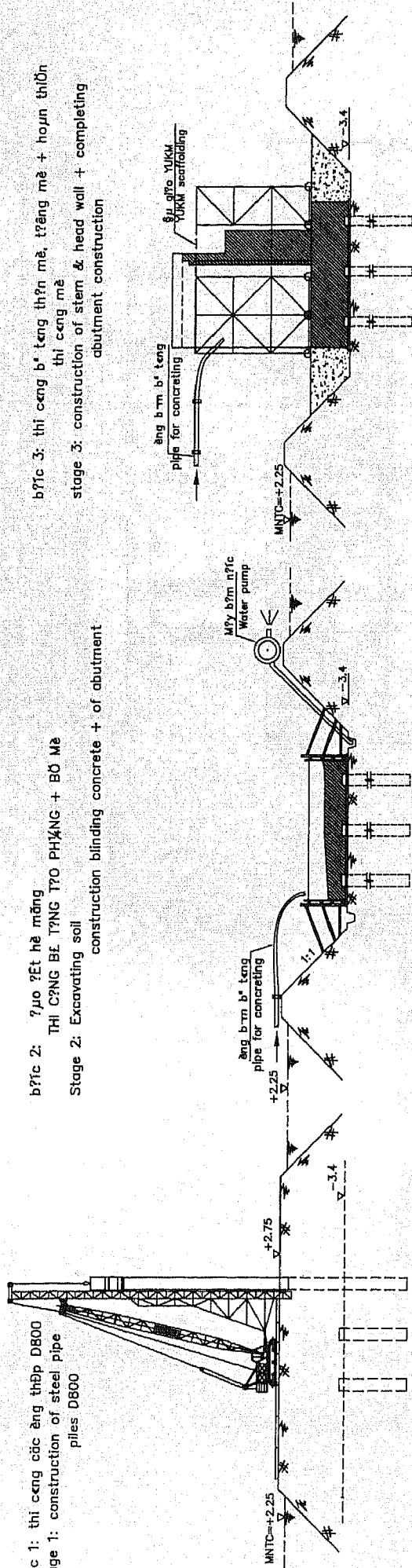

c?c b?tc thi cng tr? c?u d?n — construction method of approach bridge pier

b?tc 1: thi cng c?c ?ng th?p DB00
 Stage 1: construction of steel pipe
 piles DB00

b?tc 2: ?mu ?Et hē m?ng + thi cng b? teng b? tr?
 Stage 2: Excavating soil + construction of pile-cap
 of piers

b?tc 3: thi cng b? teng th?n tr? + ho?n thi?n
 thi cng tr?
 stage 3: construction of pier column + completing
 pier construction

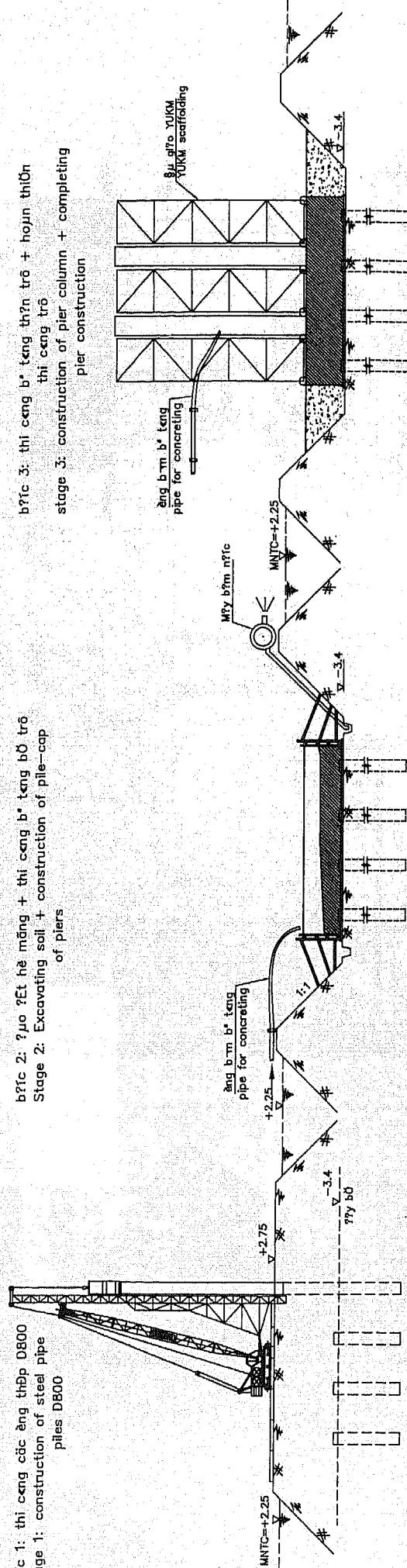

b7c 1: thi cong cac 7phn vp
stage 1: construction of locating piles

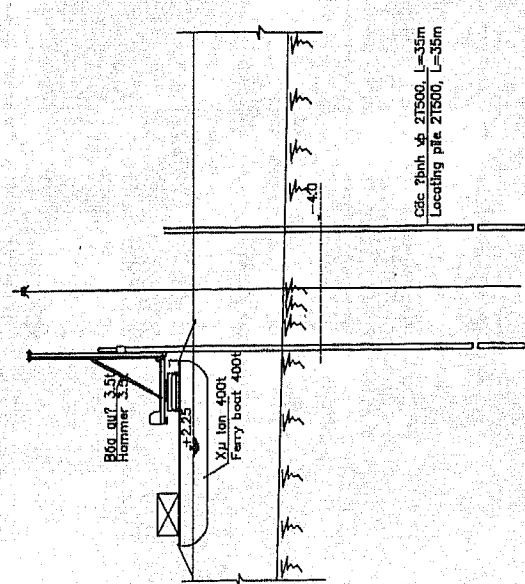

b7c 2: thi cong cac ống thép D=0.8m
stage 2: construction of steel pipe piles D=0.8m

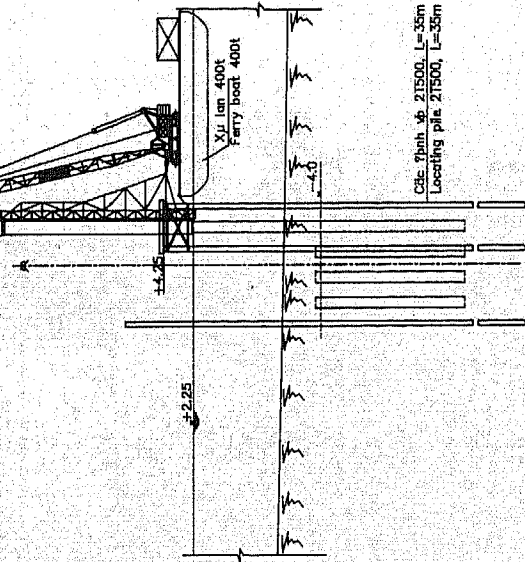

b7c 3: thi cong các vôn thép
stage 3: construction of steel sheet pile

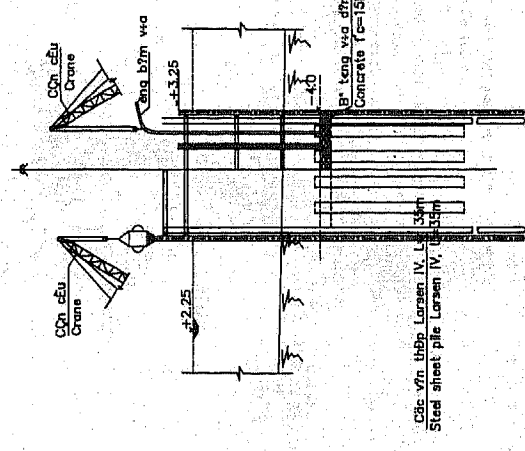

b7c 4: 7áo vét trong vông vữa các vôn thép
thi công bêt tông na móng
stage 4: Excavating soil inside sheet pile wall

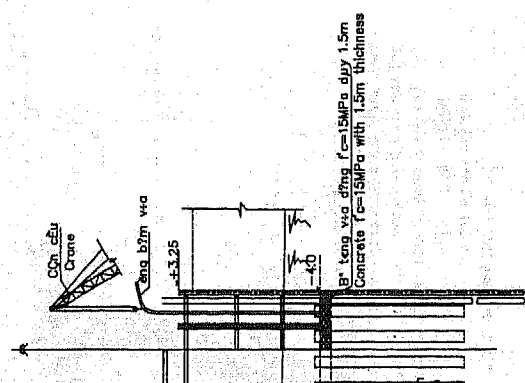

b7c 5: thi cong b' tông bô trở
stage 5: construction of pile-cap

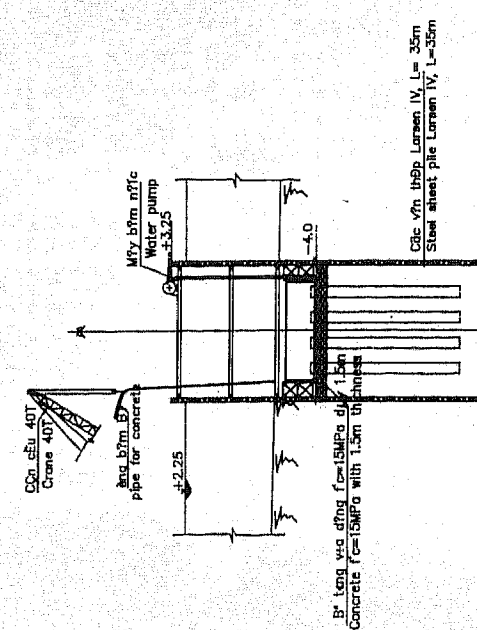

b7c 6: thi cong b' tông thàn trở
stage 6: construction of pier column

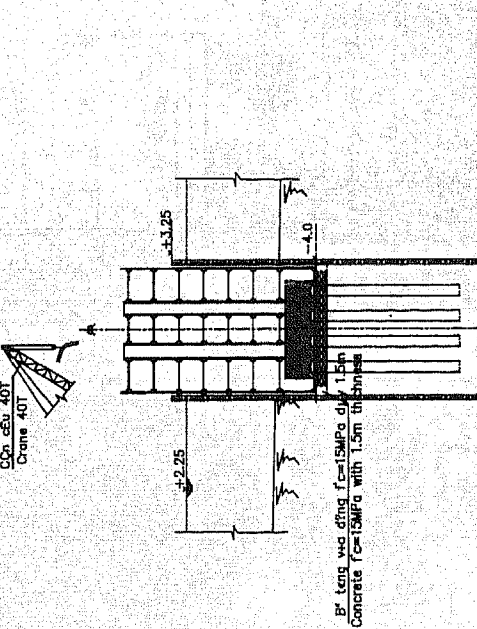

b7c 7: HOÀN THIỆN CÔNG THỨC TH. CÔNG TRÒ
stage 7: completing pier construction

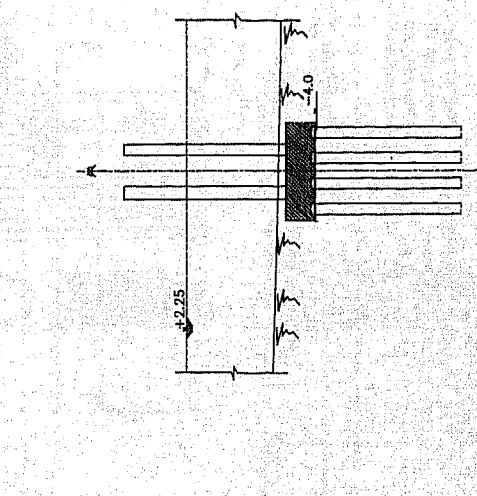

THE PREPARATORY SURVEY
OF
LACH HUYEN PORT CONSTRUCTION
(ROAD AND BRIDGE PORTION)



JAPAN INTERNATIONAL COOPERATION AGENCY (JICA)
Joint Venture of
Nippon Koei Co., Ltd. and
Japan Bridge & Structure Institute, Inc.

TITLE
Construction Method of
Approach Bridge Pier
(Off-shore)

SCALE 1:1
No. C-02

thi công trổ cẩu chính - construction method of main bridge pier

b71c 1: thi công các cọc nhồi và đặt vào khung lưới
stage 1: construction of locating piles and putting in grid frame

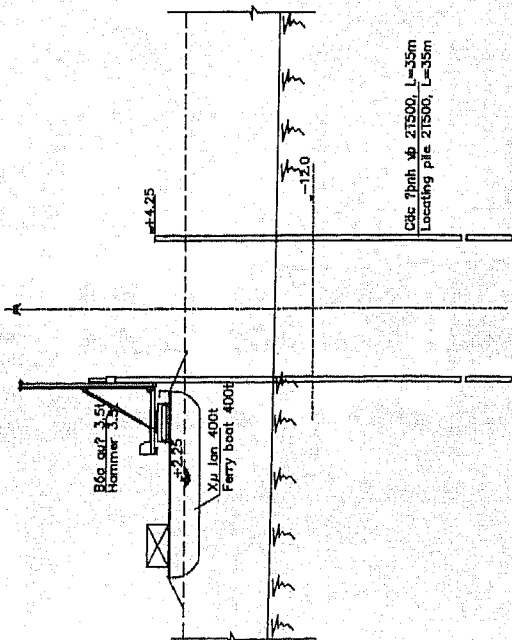

b71c 2: thi công các ống thép D=1.2m
stage 2: construction of steel pipe piles D=1.2m

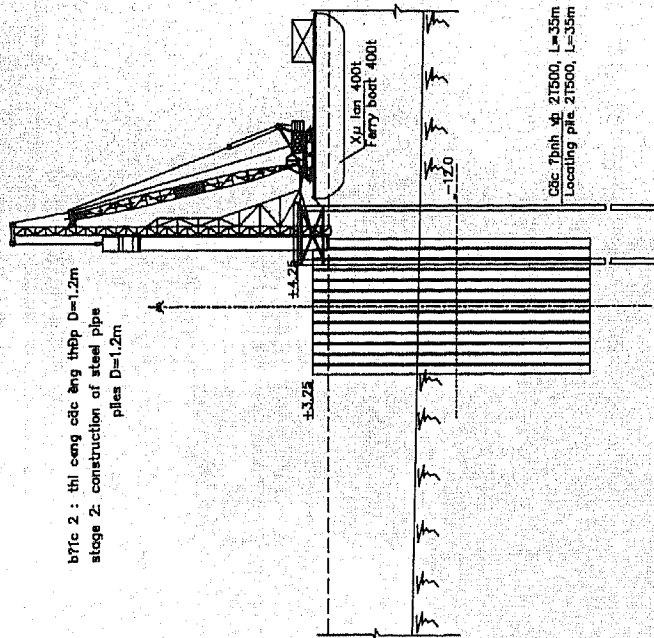

b71c 3: thi công các ống thép
stage 3: construction of steel sheet pile

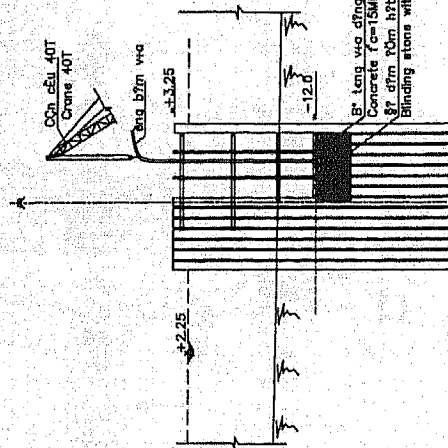

b71c 4: Đào đất trong vòng vây các cọc vữa bê tông
stage 4: Excavating soil inside sheet pile wall construction of seed concrete

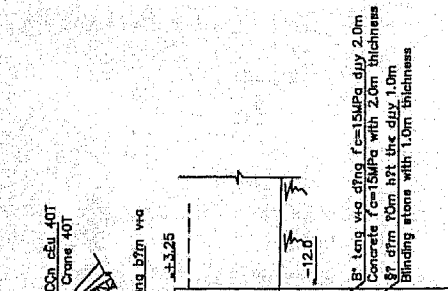

b71c 5: thi công b' teng bù trổ
stage 5: construction of pile-cap of piers

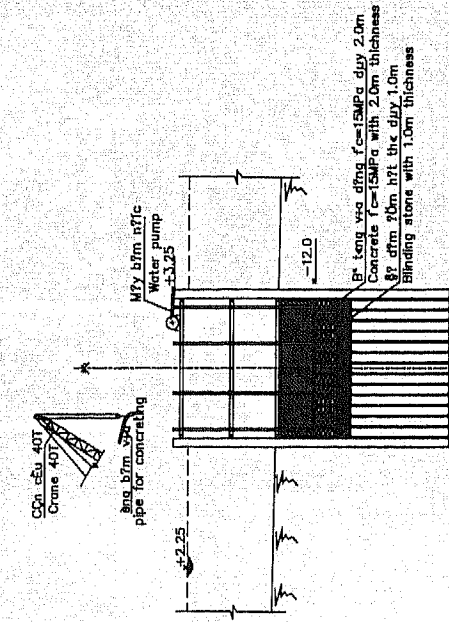

b71c 6: thi công b' teng trụ trổ
stage 6: construction of pier column

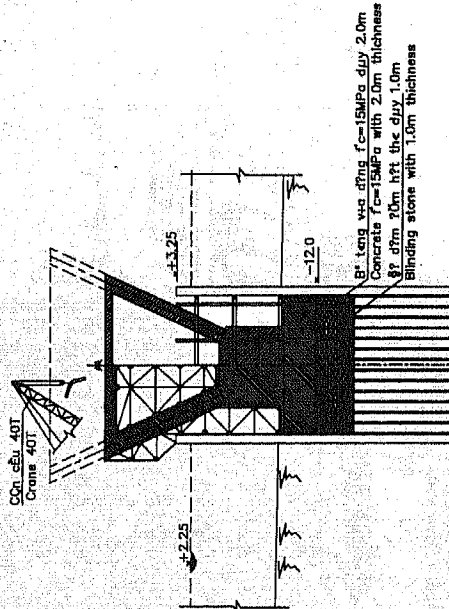

b71c 7: thi công khối 70m trổ
stage 7: thi công khối 70m trổ + cft h'c các ống thép + hoàn thiện thi công + cutting steel sheet pipe pile + completing pier construction

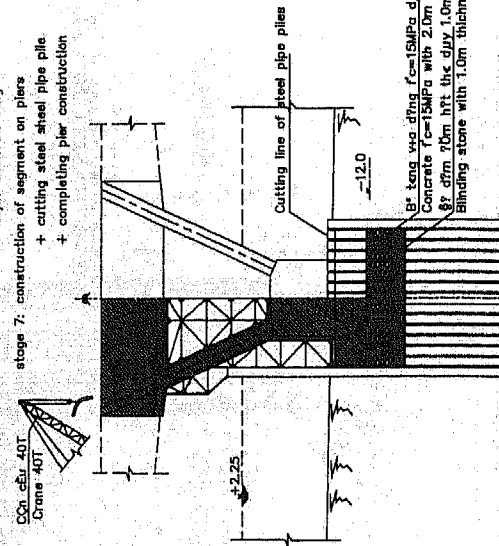

b71c 1: Lắp đặt xe 76c tại khe tr'n gối trụ
 stage 1: installation of traveller on the pier segments

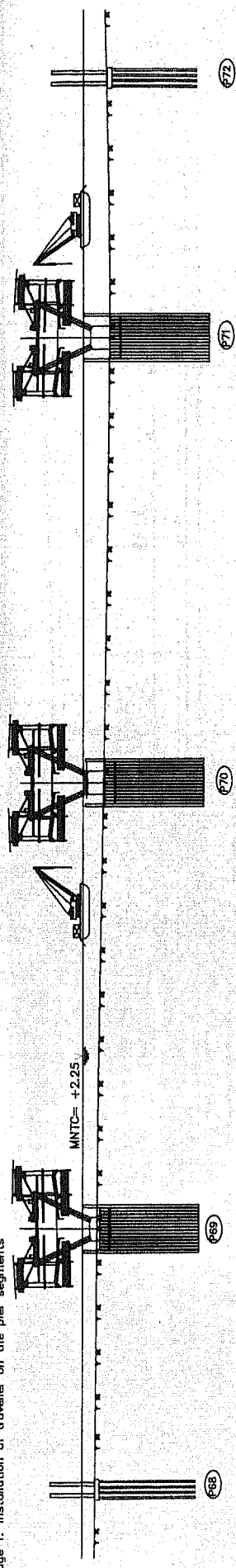

b71c 2: thi công cọc khải theo ph'ng pháp cân bằng 7ai xang
 stage 2: construction of segment by the balance cantilever method

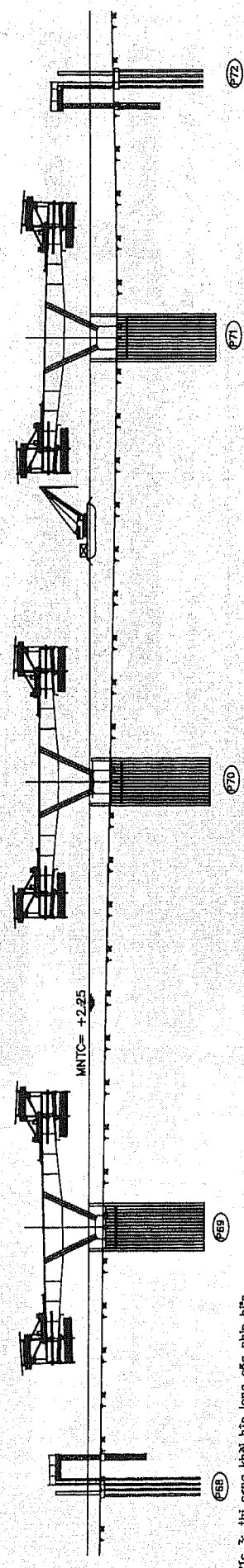

b71c 3: thi công khải h'p long đ'n nhịp b'nh
 stage 3: construction of closure segment of side span

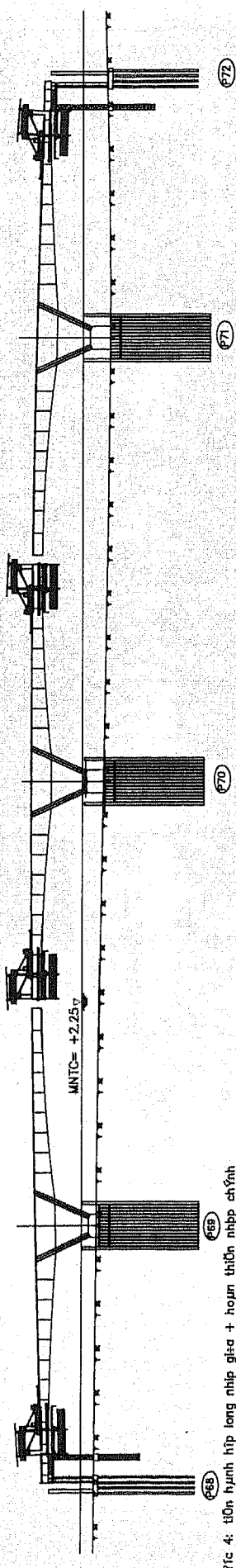

b71c 4: t'ôn hình h'p long nhịp g'ia + hoàn thi'nh nh'p ch'nh
 stage 4: construction of closure segment of main span + completing construction of main bridge

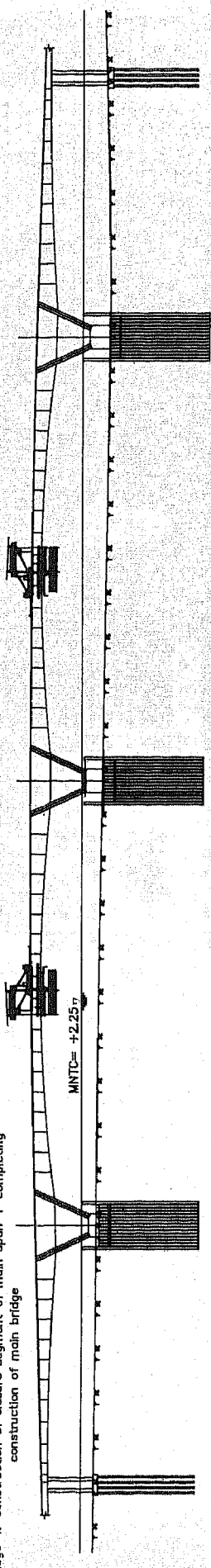

THE PREPARATORY SURVEY
 OF
 LACH HUYEN PORT CONSTRUCTION
 (ROAD AND BRIDGE PORTION)



JAPAN INTERNATIONAL COOPERATION AGENCY (JICA)
 Joint Venture of
 Nippon Koei Co., Ltd. and
 Japan Bridge & Structure Institute, Inc.

TITLE
 Construction Method of
 Main Bridge Superstructure

SCALE
 1:1000
 NO.
 C-04

Đi Tân và
đến Tân vũ

thi công kết cấu cầu phàn trên cầu dầm - construction method of approach bridge superstructure

Bảng 1: THI CÔNG NHẦP 1

STAGE 1: CONSTRUCTION OF SPAN No.1

Đi Tân và
đến Tân vũ

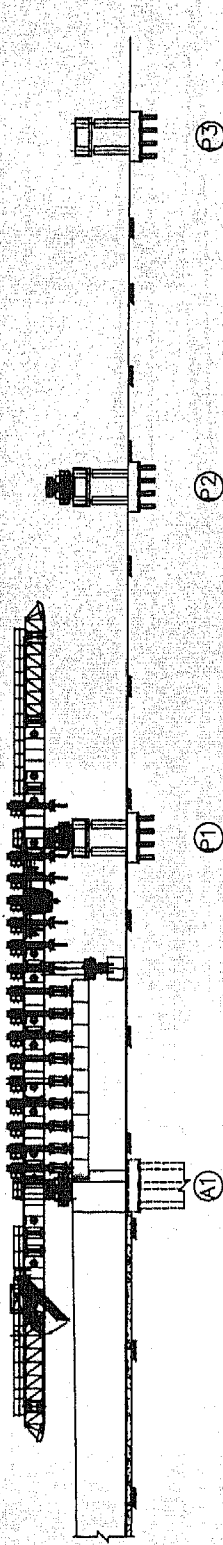

Bảng 2: THI CÔNG NHẦP 2

STAGE 2: CONSTRUCTION OF SPAN No.2

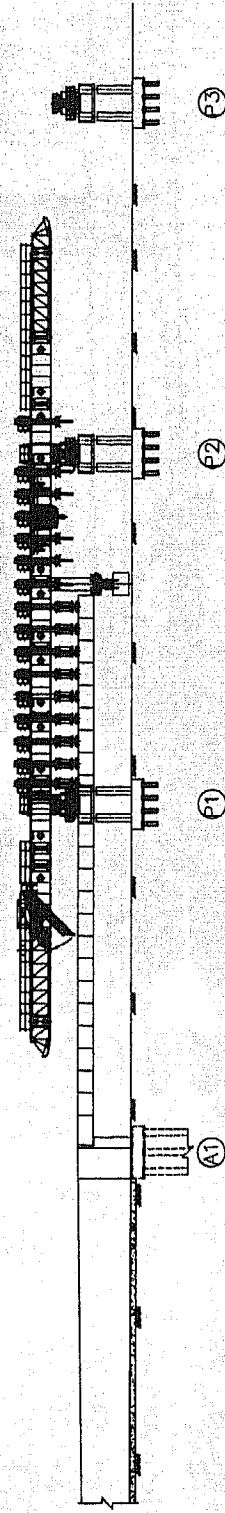

Bảng 3: THI CÔNG NHẦP 3

STAGE 3: CONSTRUCTION OF SPAN No.3

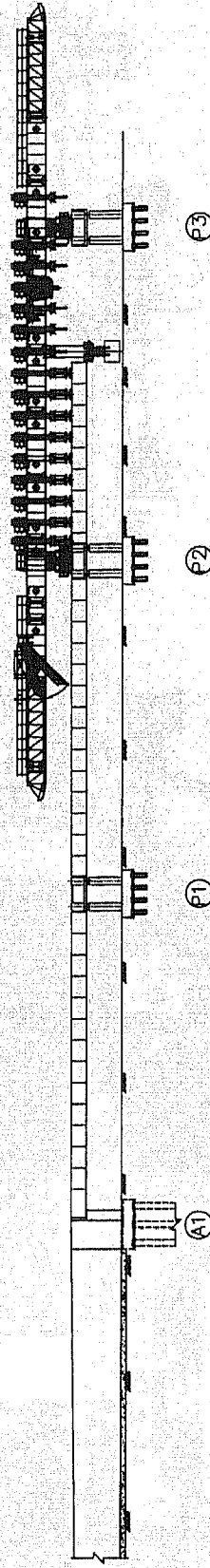

Bảng 4: - TIẾP TỤC THI CÔNG CÁC NHẦP ĐẾN KHÁC TƯƠNG TỰ
- hoàn thiện THI CÔNG NHẦP ĐẾN

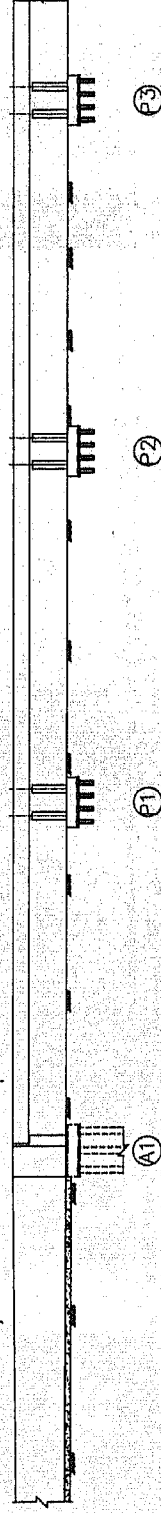

STAGE 4: - other spans are continue constructed as above stages
- CONSTRUCTION OF APPROACH SPANS IS COMPLETED

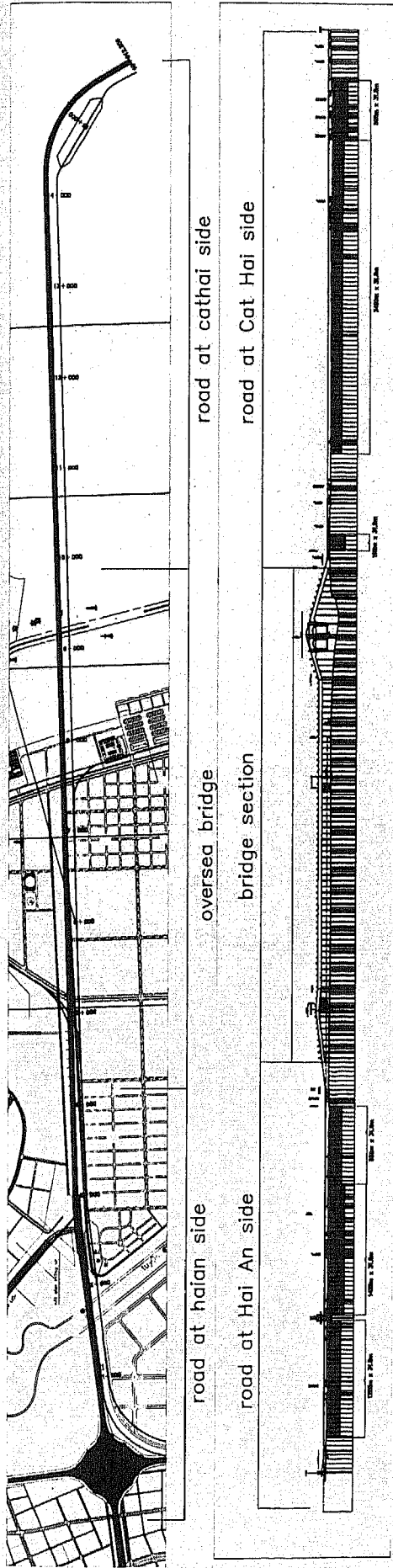

construction schedule of alternative 3a

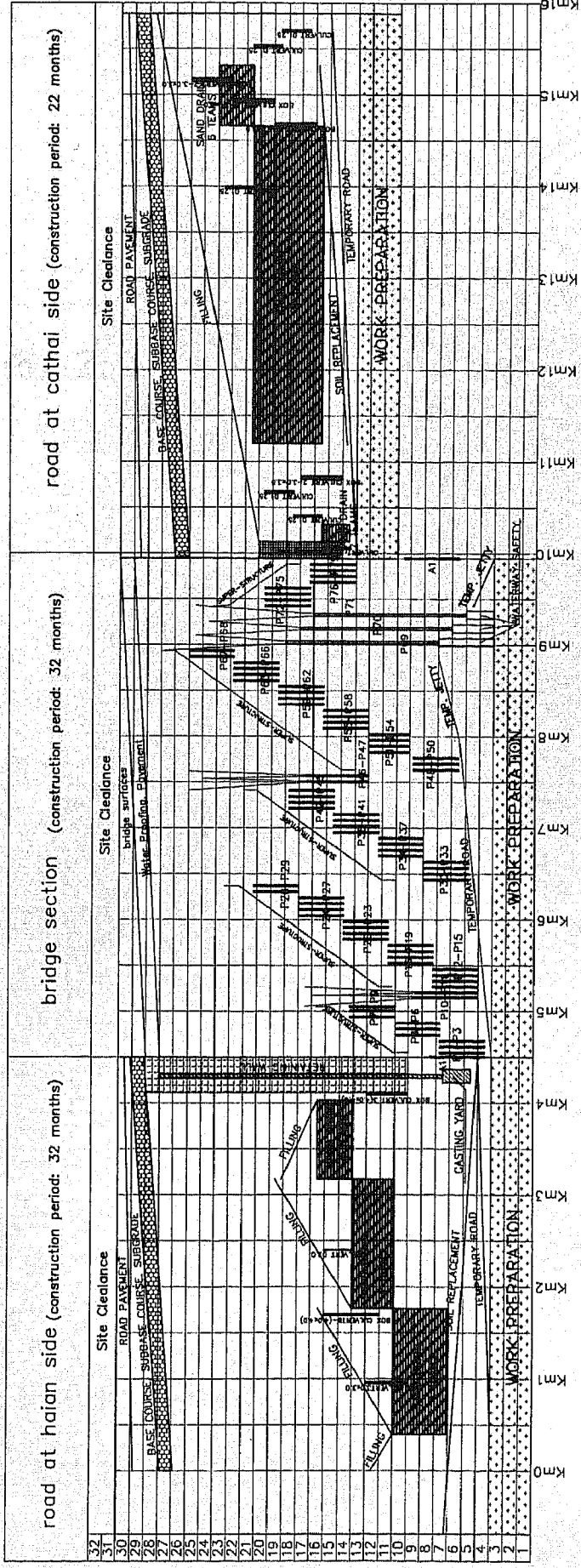

THE PREPARATORY SURVEY
OF
LACH HUYEN PORT CONSTRUCTION
(ROAD AND BRIDGE PORTION)



JAPAN INTERNATIONAL COOPERATION AGENCY (JICA)
Joint Venture of
Nippon Koei Co., Ltd. and
Japan Bridge & Structure Institute, Inc.

TITLE
CONSTRUCTION SCHEDULE

SCALE 1:50
NO. C-06

