

資 料

[資 料-1]

1. 調査団員氏名、所属

(1) 協力準備調査時

	担当業務	名前	所属
1	総括	近藤 貴之	JICA 人間開発部 技術教育課 調査役
2	計画管理	白水 健一	JICA 人間開発部 技術教育課
3	業務主任／建築計画	渡辺 政彦	システム科学コンサルタンツ株式会社
4	技術教育計画	中野 頼明	財団法人海外職業訓練協会
5	建築設計／設備計画	早原 章広	システム科学コンサルタンツ株式会社
6	機材計画／積算	福地 徳之	オフィス P. P. M
7	施工・調達計画／積算	中西 吉也	システム科学コンサルタンツ株式会社

(2) 概要説明調査時

	担当業務	名前	所属
1	総括	佐藤 俊也	JICA パキスタン事務所次長
2	計画管理	梅宮 直樹	JICA 人間開発部 高等・技術教育課
3	業務主任／建築計画	渡辺 政彦	システム科学コンサルタンツ株式会社
4	建築設計／設備計画	早原 章広	システム科学コンサルタンツ株式会社
5	機材計画／積算	福地 徳之	オフィス P. P. M

2. 調査行程

(1) 協力準備調査時

日	曜日	官側(団長/業務管理)	業務主任/建築計画	技術教育計画	建築設計/設備計画	機材計画/積算	施工・調達計画/積算	宿泊先
		a) 近藤 貴之/白水 健一	b) 渡辺 政彦	c) 中野 頼明	d) 早原 章広	e) 福地 徳之	f) 中西 吉也	
1	9月19日		移動: 成田→バンコク→ラホール			大阪→バンコク→ラホール	b) c) d) と同じ	b) c) d) e) f) ラホール
2	9月20日	月	TEVTA, GCT協議 —インベション説明-A —要請施設・機材内容 —サイト選定経緯 —GCT既存施設機材内容確認	—	GCT既存施設機材の状況視察	GCT既存施設機材の状況視察	GCT既存施設機材の状況視察	a) b) c) d) e) f) ラホール
3	9月21日	火	移動: 成田→バンコク→ラホール TEVTA, GCT協議 —教育シナリオ計画の確認 —かきまと諸君利用状況・計画 —かきまと機材利用状況・計画	—	同上	同上	同上	a) b) c) d) e) f) ラホール
4	9月22日	水	午前: 技プロ側との協議 午後: TEVTA, GCT協議 —インベション説明-B —既存施設視察	—	同上	同上	同上	同上
5	9月23日	木	TEVTA, GCT協議 —要請コードシートと優先順位 —運営体制、要員配置、予算 —実施工程、先方負担内容 —既存施設、計画サイト視察	—	—	法制度調査 —都市計画、建築基準等 —建設申請手続 —類似施設視察	TEVTA, GCT協議(運営・維持管理体制、相手国負担、事業工程)、類似施設視察	同上
6	9月24日	金	TEVTA, GCT協議 —同上 —免税措置、その他 —類似施設視察	—	—	既存施設利用状況の概要把握 —既存施設内容 —法規制と計画条件	既存機材利用状況の概要把握 —機材内容 —利用状況	自然条件調査準備 —資料収集 —サイト調査
7	9月25日	土	団内協議・資料整理 —サイト・類似施設視察	—	教育関連整理	施設関連整理	機材関連整理	—
8	9月26日	日	団内協議・資料整理 —ミニッツ調整	—	教育関連整理	施設関連整理	機材関連整理	—
9	9月27日	月	TEVTA, GCT協議 —ミニッツ協議	—	—	既存施設・機材状況(機材配置、設備状況)	—	自然条件調査開始、監視
10	9月28日	火	ミニッツ署名 (TEVTA, Chairman)	—	—	インフラ状況調査(電気、上下水道管轄部局聴取)	GCT協議機械学科(機材内容) 建築学科(機材内容)	建設業者・資材店聴取(実績、能力、労務)
11	9月29日	水	移動: ラホール→イスラマバード大使館・JICA報告、EAD表敬 イスラマバード→バンコク	—	GCT協議(かきまと、要員計画、ワゴン必要性等)	類似施設視察(大学、職業訓練校)	—	—
12	9月30日	木	建築事情調査 イスラマバード→ラホール	—	—	サイト状況調査(土地形状、高低差、障害物)	商社、代理店聴取調査(価格、メンテ体制)	サイト状況調査、自然条件調査(測量、地質調査監理)
13	10月1日	金	建築事情調査	GCT協議 —訓練計画 —優先内容	—	現地コンサルタント調査(設計基準、会社規模・能力)	同上	他ドナー聴取 b) と同じ
14	10月2日	土	団内協議・資料整理	—	—	—	—	同上
15	10月3日	日	団内協議・資料整理	—	—	—	—	同上
16	10月4日	月	類似施設調査 施設・機材運営	GCT協議 —教員体制、施設機材利用体制	—	法制度調査(都市計画、法規、基準、建設申請手続き)	商社、代理店聴取調査(価格、メンテ体制)	建設業者・資材店聴取(実績、能力、労務)
17	10月5日	火	市建築課 消防 GCT建築学科	企業訪問 —機械、建築学科就職状況 —企業側の要望	—	自然条件調査(気象、地震、風)、インフラ状況調査(電気、上下水道)	企業訪問 —機械、建築学科就職状況 —企業側の要望	同上
18	10月6日	水	州政府PDDよりミニッツサイン受領	州立大学訪問 —機材整備状況塔	—	建築設計関連調査	AM: 類似施設調査 施設・機材運営	同上
19	10月7日	木	GCT協議 —協力施設案の概要協議 —協力機材案の概要協議	州立大学訪問 —卒業生の動向	—	同上	機材計画関連調査	自然条件調査監理
20	10月8日	金	協力計画案検討	—	—	協力施設案作成	協力機材案作成	—
21	10月9日	土	団内協議 各専門分野の進捗状況確認	—	—	—	—	—
22	10月10日	日	資料整理 ラホール→イスラマバード	—	—	—	—	—
23	10月11日	月	午前: JICA事務所訪問 建設事情調査 イスラマバード→ラホール	ラホール→イスラマバード→バンコク	—	建設事情調査	ラホール→イスラマバード→バンコク	建設・調達調査
24	10月12日	火	GCT機械学科協議(施設規模、平面計画)	バンコク→成田	—	GCT機械学科協議(施設規模、平面計画)	バンコク→大阪	自然条件調査監理
25	10月13日	水	GCT建築学科協議(施設規模、平面計画)	—	—	GCT建築学科協議(配置、平面計画)	—	建設・調達調査
26	10月14日	木	TEVTA, GCT協議(協力施設案、優先順位)	—	—	TEVTA, GCT協議 b) と同じ	—	同上
27	10月15日	金	ラホール→イスラマバード JICA報告 現地施工業者調査	—	—	補足調査	—	補足調査
28	10月16日	土	類似施設視察 イスラマバード→ラホール 団内協議	—	—	補足調査 団内協議	—	補足調査 団内協議
29	10月17日	日	資料整理 イスラマバード→バンコク	—	—	資料整理 イスラマバード→バンコク	—	資料整理 イスラマバード→バンコク
30	10月18日	月	バンコク→成田	—	—	バンコク→成田	—	バンコク→成田

TEVTA: パンジャブ州技術教育・職業訓練庁
GCT: レイルウェイロード技術短期大学
EAD: パキスタン国経済協力部
PDD: パンジャブ州計画開発局

(2) 概要説明調査時

	日	曜日	官側（団長／業務管理）	業務主任／建築計画	建築設計／設備計画	機材計画／積算	宿泊先
			a) 佐藤俊也／梅宮直樹	b) 渡辺 政彦	c) 早原 章広	d) 福地 徳之	
1	2月13日	日	空路移動：成田→バンコク→ラホール	←	←	大阪→バンコク →ラホール	a) b) c) d) ラホール
2	2月14日	月	TEVTA, GCT協議 －概要調査報告書説明 －ミニッツ案協議 －サイト、既存施設視察	←	←	←	同上
3	2月15日	火	GCT協議 －計画内容説明 －先方負担事項確認 類似施設視察 (パンジャブ工科大学、パンジャブ大学等)	←	ラホール市許認可関連調査 －許認可再確認 －現地技術者面談	GCT機材説明・協議 －機材内容説明 －据付個所再調整	同上
4	2月16日	水	団内協議・資料整理 －ミニッツ調整	←	←	←	同上
5	2月17日	木	午前：ミニッツ署名 (TEVTA, Chairman) 午後：ミニッツ署名 (パンジャブ州開発局)	←	施設補足調査 －資材 －設備機材	GCT協議 －据付個所再調整 －配電盤等再確認	同上
6	2月18日	金	車両移動：ラホール→イスラマバード 大使館報告 空路移動：イスラマバード→バンコク	←	同上	同上	同上 a) 機中 b) イスラマバード
7	2月19日	土	～バンコク→成田	建築事情調査 空路移動：イスラマバード→ラホール	施設関連整理	機材関連整理	b) c) d) ラホール
8	2月20日	日	/	団内協議・資料整理	← 施設関連整理	← 機材関連整理	同上
9	2月21日	月		GCT協議 －先方負担事項再確認 －計画内容確認	施設関連補足調査	機材関連補足調査	同上
10	2月22日	火		TEVTA協議 －先方負担事項再確認	同上	同上	同上
11	2月23日	水		午前：TEVTA協議 午後：車両移動、 ラホール→イスラマバード 空路移動：イスラマバード→バンコク	←	←	b) c) d) 機中
12	2月24日	木		～バンコク→成田	←	←	～バンコク→大阪

TEVTA： パンジャブ州技術教育・職業訓練庁
GCT： レイルウェイロード技術短期大学
EAD： パキスタン国経済協力部
PDD： パンジャブ州計画開発局

3. 関係者（面談者）リスト

（調査先・面談者）

氏名	役職	所属機関等
パキスタン中央政府 Central Government of Pakistan		
ZAFAR HASAN REZAH	Joint Secretary	Economic Affair Division, Government of Pakistan
パンジャブ州政府 Government of Punjab Province		
UBAID RUBBANI QURESHI	Secretary (Former at October 2010)	Planning and Development Department, Government of Punjab
ALI TAHIR	Secretary (Present at February 2011)	Ditto
技術教育・職業訓練庁 Technical Education and Vocational Training Authority (TEVTA), Punjab Province		
SAEED AHMED ALVI	Chairperson	TEVTA, Punjab
KHAWAJA ADNAN ZAHIR	General Manager (Operations)	Ditto
MUHAMMD ABID JAVED	Coordinator	Ditto
SH. FAROOK AHMED	Advisor (Project & Planning)	Ditto
JAWED IQBAL MALIK	General Manager (Academics)	Ditto
AMJAD DURAIZ	General Manager (Operations)	Ditto
AQUIB SHARIF	Deputy Manager (M & E)	Ditto
Engr. IMTIAZ AMJAD	Assistant Manager (Works/Civil)	Ditto
RAB NAWAZ	Sub Engineer (Electrical)	Ditto
SHAUKAT ALI	Sub Engineer (Civil)	Ditto
ラホール、レイルウェイ技術教育短大 GCT Railway Road College, Lahore		
ARIF ALI NADEEM	Principal	GCT Railway Road, Lahore
MUHAMMAD AQEEL	In charge Mechanical Dept.	Ditto
AMJAD ELAHI	Senior Instructor Mechanical Dept.	Ditto
MAHMOOD AKHTAR KHAN SALEEM	In charge Architecture Dept.	Ditto
ABDUL JABBAR	Senior Instructor Architecture Dept.	Ditto
Engr. UMAR HAYAT	Instructor Electronical / Electronics	Ditto
ラホール市庁・消防 Town Hall / Related Organization, Lahore		
QAMAR UL ISLAM	District Officer (SP) City District Officer Lahore	Town Hall, Lahore
QAMAR UL ISLAM	District Officer (SP) City District Officer Lahore	Ditto
RAJA MUHAMMAD ALTAF	Fire Officer City District Govt Lahore	Ditto
MAZHAR AHMED	Civil Defense Officer Lahore	Ditto
MANZOOR HUSSAIN	Assistant Meteorologist	Metrological Station, Lahore

IJAZ AHMED	Assistant Director Physical	Quality Control Center Ferozpur Road Lahore
ABDOUL HAQ BHATTI	Chief Planning Officer	Govt. of Punjab Health Department Lahore
大学・短大 University / College		
Dr. JAMAL TARIQ MIAN	Chairman, Mechatronics & Control Engineering Dept,	University of Engineering and Technology, Lahore
Dr.HAMEED ULLAH MUGHAL	Professor & Chairman, Mechanical Department	Ditto
Prof. Dr. ANIS A SIDDIQI	Professor and Head Architecture Dept.	College of Arts & Design
他ドナー Other Donor		
MUHAMMAD A AMIR	Monitoring & Evaluation Officer	GTZ Provincial Management Unit Punjab School Libraries Project Lahore
建築家・エンジニア Architect / Engineer		
PARAVEL IQBAL	Lahore Chapter Institute of Architects, Pakistan	Architect, Lahore
Najib Ahmed	Senior Engineer	Design men, Islamabad (測量・地質調査コンサルタント)
その他 Others		
Khalio Bashir Butt	Executive Engineer	LESCO
Usman Babar	Sub Divisional Officer	WASA
在パキスタン日本国大使館		
大坪 成	一等書記官	在パキスタン日本国大使館
後藤 晃	二等書記官	同上
パキスタン JICA 事務所		
西片 高俊	所長	JICA パキスタン事務所
佐藤 俊也	次長	同上
原 典子	所員	同上
佐伯 武	所員	同上
横田 知映子	所員	同上
Nazia Seher	所員	同上
JICA 技術協力プロジェクト (パンジャブ州技術短期大学 : GCT レイルウェイ・ロード校)		
曾武川 建	チーフアドバイザー	技術教育改善プロジェクト
伊藤 稔	建築専門家	同上
澤田 幸次	機械専門家	同上

4. 討議議事録 (M/D)

4-1 討議議事録 (協力準備調査時)

MINUTES OF DISCUSSIONS
ON
THE PREPARATORY SURVEY
ON
THE PROJECT FOR STRENGTHENING OF DAE MECHANICAL &
ARCHITECTURE DEPARTMENTS IN GCT RAILWAY ROAD
OF PUNJAB PROVINCE

In response to the request from the Government of Pakistan (hereinafter referred to as "GOP"), Japan International Cooperation Agency (hereinafter referred to as "JICA") decided to conduct a Preparatory Survey on the Project for Strengthening of DAE Mechanical & Architecture Departments in GCT Railway Road of Punjab Province (hereinafter referred to as "the Project").

JICA sent to Pakistan Preparatory Survey Team (hereinafter referred to as "the Team"), headed by Mr. Takayuki Kondo, Human Development Department, JICA, and is scheduled to stay in the country from September 19, 2010 to October 18, 2010. The Team held discussions with the officials concerned of GOP and conducted a field survey at the study areas.

In the course of discussions and field survey, both parties confirmed the main items described in the attached sheets. The Team will proceed to further works and prepare the Preparatory Survey Report.

Lahore, September 28, 2010



Mr. Takayuki Kondo
Leader
Preparatory Survey Team
Japan International Cooperation Agency

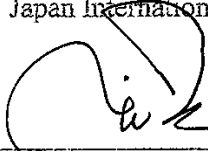

Mr. Ubaid Rubbani Qureshi
Secretary
Planning and Development Department
Government of the Punjab



Saeed Ahmad Alvi
Chairperson
Technical Education and Vocational
Training Authority, Punjab

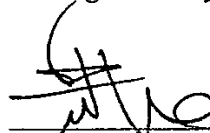

Mr. Zafar Hasan Reza
Joint Secretary
Economic Affairs Division
Government of Pakistan

ATTACHMENT

1. Objective of the Project

The objective of the Project is to improve the capacity of Mechanical and Architecture Departments of Government College of Technology Railway Road Lahore (hereinafter referred to as "GCT Railway") through construction of Architecture building and improving the necessary equipments of Mechanical and Architecture Departments.

2. Modification of the title of the Project

After discussion with the Team, both parties agreed to modify the Project title from "Strengthening of DAE Mechanical & Architecture Departments in GCT Railway Road and other institutes include GCT(s) of Punjab" to "Strengthening of DAE Mechanical & Architecture Departments in GCT Railway Road of Punjab Province". After consultation with the Government of Japan, the Project title shall be finalized.

3. Project site

The site of the Project is GCT Railway in Punjab Province.

4. Responsible and Implementing Agency

4.1 The Counterpart Ministry is Economic Affairs Division, Ministry of Economic Affairs and Statistics.

4.2 The Responsible Agency is Government of the Punjab Province.

4.3 The Implementing Agency is Technical Education and Vocational Training Authority (hereinafter referred to as "TEVTA"), Punjab.

4.4 The Executing Agency is Government College of Technology Railway Road Lahore.

5. Components requested by the GOP

After discussions with the Team, the components described in Annex-1 were finally requested by GOP. JICA will assess the appropriateness of the request and will recommend to the Government of Japan for approval.

6. Japan's Grant Aid Scheme

6-1. GOP understood the Japan's Grant Aid Scheme explained by the Team, as described



in Annex-3.

6-2. GOP will take the necessary measures, as described in Annex-4, for smooth implementation of the Project, as a condition for the Japanese Grant Aid to be implemented.

7. Schedule of the Study

7-1. The consultants will proceed to further studies in Pakistan until 17 October, 2010.

7-2. JICA will prepare the draft final report in English and dispatch the draft report explanation mission to Pakistan in order to explain its contents around mid February, 2011.

7-3. In case that the contents of the draft final report is accepted in principle by the GOP, JICA will complete the final report and send it to the GOP by around June, 2011.

8. Other relevant issues

8-1. Facilities and equipment within the scope of consideration under the Project comprise that essential for learning under the revised mechanical and architecture curricula at GCT Railway and which cannot be provided by Technical Cooperation Project.

8-2. Facility design will adhere to stipulations under urban planning law and construction standard regulations. It will also ensure on-site access and exit ways for safety purposes.

8-3. With regard to the Mechanical Department, the Pakistan side has requested expansion of the existing one story building into a two story building. However, structural concerns make this proposal unsuitable for consideration under grant-aid assistance. Construction or expansion of the building of Mechanical Department will not be included in the Project.

8-4. From September 2010, GCT Railway began accepting females into its Architecture Department. New building will include the minimum components to accommodate these new female students as described in Annex-1.

8-5. Tax Payment

With regard to the implementation of the Project, GOP has committed to take appropriate measures to exempt custom duties, value-added tax, and other fiscal levies which may be imposed in Pakistan.

8-6. Approval of PC-1

The Team requested that the Pakistani side should complete preparation and approval of the PC-1 from Central Development Working Party (CDWP) by the end of March



2011 as it is one of the prerequisites for Government of Japan to make commitment of grant for the Project.

Both sides agreed that the Team will provide the cost estimates by the middle of December 2010 to the Government of Punjab for processing of PC-1 for its approval.

The Pakistani side will promptly inform JICA Pakistan office the result after the approval by CDWP.

Annex-1: Components Requested by the Pakistan Side

Annex-2: Project Site Location Map

Annex-3: Japan's Grant Aid Scheme

Annex-4: Major Undertakings by each Government



A small handwritten mark or signature, possibly initials, located at the bottom center of the page.

A handwritten signature, possibly 'B', located at the bottom right of the page.

A handwritten signature, possibly 'ds', located at the bottom right of the page.

COMPONENTS REQUESTED BY THE PAKISTAN SIDE

Annex-1

The definition of Priority

A: Necessary, B: Less necessary than "A", C: Unnecessary (It is not an object of Preparatory Survey)

1. Facilities (Architecture Course Practical Training Building)

No.	Categories		Major Components (Rooms)	Q'ty	Remarks (Following matter should be respected)	Priority
1.	Training & Education	1-1	Special Class Room-CAD (computer)	2	Server and Printer Corner or Room	A
		1-2	Special Class Room-Drawing (drawing table)	2	Equipment Store Corner or Room	A
		1-3	Special Class Room-Model Making	1	Ditto	A
		1-4	Practical Training Work shop - Practical training space * Material Test * Concrete Practice * Plumbing Practice * Metal Practice * Electrical Practice - Survey Equipment Room - Material and Tool Storage	1	Server and Printer Corner or Room	A
		1-4	Common Class Room (Theory Education)	2	Equipment Store Corner or Room	A
		1-5	Storage	unit	Document and Equipment Store	A
2.	Management	2-1	Teacher's Room (Including TOT)	1	Assistant use same room	A
		2-2	Copy and Documentation Room	1	Near the Teacher's room	A
		2-3	Meeting Room	1		A
		2-3	Storage	unit	Document and Equipment Store	A
3.	Girl's Education	3-1	Girls Common Room	1	Locker	A
		3-2	Toilet for Girl's Student	1		A
		3-3	Cafeteria and kitchen	1	Easy access to outside	A
4.	Common	4-1	Reception and Guard Room	1		A
		4-2	Toilet for Boy's Student	1		A
		4-3	Toilet for Women	1		A
		4-4	Toilet for Men	1		A
		4-5	Common Toilet (Men/Women)	1		A
		4-6	Tea Kitchen	1		A
		4-7	Entrance Hall	1		A
		4-8	Storage	unit	Document and Equipment Store	A
		4-9	Machine Room, Electrical Panel Room	unit		A
		4-10	Stairs, Corridor	unit		A
5.	Others	5-1	Garbage Stock Depot.	unit		B
		5-3	External Work Around the New Building	unit		A



2. Equipment

The definition of Priority

A: Necessary, B: Less necessary than "A", C: Unnecessary (It is not an object of Preparatory Survey)

Shadowed cells mean the strongly requested by the Client side in the same priority.

2-1. Mechanical Course Equipment

No.	Item	Q'ty	Remarks	Priority
1	Basic Machine Shop			
1-1	Lathe Machine	6		A
1-2	Bench Type Drilling Machine	2		A
1-3	Band Saw	1		C
2	Advance Machine Shop			
2-1	Lathe Machine	2		A
2-2	Hobbing Machine	1		A
2-3	Universal Milling Machine	2		A
2-4	Shaper	1		B
2-5	Surface Grinder	1		A
2-6	Universal Tool and Cutter Grinder	1		B
2-7	Micrometer	5		B
2-8	Digital Caliper	5		B
2-9	Gear Puller	3		C
2-10	Handy Drilling Machine	5		C
2-11	Handy Disc Grinder	5		C
3	Metrology Lab.			
3-1	Micrometer	10		B
3-2	Anvil Micrometer	5		B
3-3	Digital Caliper	10		B
3-4	Digital Pitch Caliper	5		B
3-5	Dial Indicator	10		B
3-6	Digital Depth Gauge	10		B
3-7	Digital Height Gauge	5		B
3-8	Digital Bevel Protractor	6		C
3-9	Dial Caliper	5		A
3-10	Dial Bore Gauge	3		B
3-11	Dial Caliper Gauge	3		B
3-12	Plug Gauge	3		C
3-13	Gauge Block Set	3		C
3-14	Sine Bar	5		C
3-15	Plug Gauge set	3		C
3-16	Gear Tooth Micrometer	3		C
3-17	Inner Micrometer	3		A
3-18	Groove Width Caliper	3		A
3-19	Mechanical Comparator	2		A
3-20	Electrical Comparator	2		A
3-21	Engineering Microscope	2		B
3-22	Depth Gauge	10		B
3-23	Engineering Square	10		C
3-24	Granite Surface Plate	2		C
3-25	Steel Surface Plate	4		B
3-26	Snap Gauge set	10		B
3-27	Ring Gauge set	2		B



2-1. Mechanical Course Equipment

No.	Item	Q'ty	Remarks	Priority
3-28	Thread Ring Gauge	5		B
3-29	Protractor	10		B
3-30	Digital Surface Tester	1		C
3-31	Tube Micrometer	5		C
3-32	Autocolymeter	1		C
3-33	3-Point Caliper	5		C
3-34	Point Micrometer	5		B
3-35	Profile Projector	1		C
3-36	Depth Micrometer	4		A
3-37	Laser Length Measuring Instrument	1		C
3-38	V Block	10		C
3-39	Level	10		C
3-40	Thickness Guage	10		C
3-41	Radius Guage	5		B
3-42	Screw Pit Guage	10		B
3-43	Wire Guage	10		C
3-44	Universal Gear Inspection Equipment	1		B
3-45	Digital Guage Tester	1		B
3-46	Taper Guage	3		B
3-47	Pararell Bar	10		A
3-48	Surface Roughness Standard Piece	2		A
3-49	Drill Guage	2		A
3-50	Square V Block	5		A
3-51	Marking Needle	20		C
3-52	Surface Guage	20		C
3-53	Plastic Hummer	20		C
3-54	Punch	20		C
3-55	Compus	20		C
4	Welding Shop			
4-1	Arc Welding Machine	6		B
4-2	TIG Welding Machine	2		A
4-3	MAG welding Machine	2		A
4-4	Plasma Cutting Machine	1		A
4-5	Welding Table	16		C
4-6	Forging Furnace	5		B
4-7	Pedestal Grinder	1		A
4-8	Gas Mani Fold System	1		A
4-9	Oxygen Gas Cylinder	5		B
4-10	Acetylene Gas Cylinder	5		B
4-11	Oxy-Acetylene Gas Cutting Torch	5		B
4-12	Oxy-Acetylene Gas Welding Torch	5		B
4-13	Anvil	5		C
4-14	Swage Block	5		C
4-15	Forging Pincer	10		C
4-16	Large Hummer	10		C
4-17	Smasher	10		C
4-18	Hand Vice	30		B
4-19	File set			C
4-20	Welding Shield	20		B

2-1. Mechanical Course Equipment

No.	Item	Q'ty	Remarks	Priority
4-21	Leather Glove	20		C
4-22	Welding Holder	5		C
4-23	Welding Earth Clip	5		C
4-24	Air Compressor	1		A
4-25	Welding Apron	20		C
4-26	Welding Glass	10		C
4-27	Foot Cover	20		C
4-28	Wire Brush	20		C
4-29	Scriber	20		C
4-30	Cylinder Rack	4		B
4-31	Handy Disc Grinder	5		B
5	Foundry Shop			
5-1	Tilting Crucible Furnace	1		A
5-2	Cupola Furnace	1		B
5-3	Jolt Squeeze Molding Machine	1		A
5-4	Sand Milling Machine	1		A
5-5	Permeability Meter	1		A
5-6	Mold Tester	1		A
5-7	Pyrometer	2		A
5-8	Ladle	4		B
5-9	Shank	4		B
5-10	Ladle Shank	4		B
5-11	Crucible	8		B
5-12	Mold Box	8		B
5-13	Power Riddle Machine	1		B
5-14	Pedestal Grinder	1		A
5-15	Air Compressor	1		A
5-16	Air Blower	2		A
5-17	Air Gun	5		B
5-18	Trovel	20		B
5-19	Silk	20		B
5-20	Large Hummer	10		C
5-21	Forging Pincer	5		C
5-22	Riddle	10		C
5-23	Goggle	20		C
5-24	Level	5		C
5-25	Leather Glove	20		C
5-26	Spatula	20		B
5-27	Shovel	10		C
5-28	Hand Saw	20		C
6-29	File set	20		C
5-30	Chisel set	10		C

2-1. Mechanical Course Equipment

No.	Item	Q'ty	Remarks	Priority
6	Metal Shop			
6-1	Bench Vice	10		C
6-2	Rig Spanner Set	5		C
6-3	Socket Spanner Set	5		C
6-4	Pedestal Grinder	1		C
6-5	Power Hack Saw	2		B
6-6	Disc Cutter	2		A
6-7	Manual Sheet Bending Machine	2		A
6-8	Manual Sheet Rolling Machine	2		B
6-9	Manual Sheet Shearing Machine	2		B
6-10	Handy Drilling Machine	2		B
6-11	Work Table	10		C
6-12	Micrometer	3		A
6-13	Digital Caliper	5		B
6-14	Surface Plate for Sheet Metal	4		A
6-15	Lever Shear	5		B
6-16	Chisel	10		C
6-17	Hammer	10		C
6-18	Steel Snip	10		C
6-19	Tong	10		C
6-20	File Set	10		C
7	Material Testing and Heat Treatment Lab.			
7-1	Brinell Hardness Testing Machine	1		A
7-2	Rockwell Hardness Testing machine	1		A
7-3	Izod Impact Testing machine	1		C
7-4	Universal Testing Machine	1		C
7-5	Sample Cut-Off Machine	1		C
7-6	Sample Mould Press	1		C
7-7	Sample Polishing Machine	2		C
7-8	Metallurgical Microscope	1		A
7-9	Torsion Testing Machine	1		A
7-10	Rotation Fatigue Testing Machine	1		A
7-11	Electric Annealing Furnace	1		A
7-12	Hardening and Quenching Bath	1		A
7-13	Pedestal Grinder	1		B
7-14	Ultrasonic Detecting Equipment	1		B
8	Hydraulics Lab.			
8-1	Fluid Friction Apparatus	2		B
8-2	Venturi Meter Apparatus	1		A
8-3	Bernoulli's Theorem Demonstration	1		A
8-4	Orifice Flow Apparatus	1		A
8-5	Apparatus of Energy Losses in Bends	1		A
8-6	Centrifugal Pump Apparatus	1		B
8-7	Axial Pump Apparatus	1		B
8-8	Piston Pump Apparatus	1		B
8-9	Pelton Turbine	1		B
8-10	Axial Flow Turbine	1		B
8-11	Francis Turbine	1		A
8-12	Radial Flow Turbine	1		A

2-1. Mechanical Course Equipment

No.	Item	Q'ty	Remarks	Priority
8-13	Hydraulic Equipment Set	2		A
8-14	Hydraulic Bench	1		A
8-15	Axial Pump (Sectional Cut Model)	1		A
8-16	Ball Valve (Sectional Cut Model)	1		A
8-17	Vane Pump (Sectional Cut Model)	1		A
8-18	Piston Pump (Sectional Cut Model)	1		A
8-19	Digital Length Measuring Equipment	1		A
8-20	Digital Tachometer	3		C
9	CNC & Mold Making Lab.			
9-1	Vertical Machining Center	1		A
9-2	Turning Center	1		A
9-3	CNC Wire Cut	1		B
9-4	CNC EDM Sinker	1		C
9-5	CNC Laser Cutting Machine	1		C
9-6	Coordinate Measuring Machine	1		A
9-7	Robotics Equipment Kit	1		A
9-8	Computer	10		A
9-9	2-plate Sample Mold	2		C
9-10	DVD Video for mold making and molding	1		A
9-11	Manual Injection Molding machine	2		B
9-12	Pneumatic Equipment Set	2		A
9-13	Micrometer	3		A
9-14	Digital Caliper	10		C
9-15	Surface Gauge	5		B
9-16	Steel Surface Plate	1		A
9-17	Depth Gauge	3		A
10	Thermodynamics Lab.			
10-1	Diesel Engine Injection (Sectional Cut	1		C
10-2	Gasoline Engine (Sectional Cut Model)	1		C
10-3	Diesel Engine (Sectional Cut Model)	1		C
10-4	Steam Engine (Sectional Cut Model)	1		C
10-5	Boiler (Sectional Cut Model)	1		C
10-6	Gasoline Engine Testing Apparatus	1		C
10-7	Diesel Engine Testing Apparatus	1		C
10-8	Ignition Point Testing Machine	1		A
10-9	Air Compressor Testing Machine	1		B
10-10	Gas Turbine Testing Machine	1		B
10-11	Engine Assembling and Disassembling Kit	4		C
10-12	Steam Boiler Experiment Apparatus	1		B
11	Wood Work Shop			
11-1	Wood Turning Lathe	1		A
11-2	Band Saw Machine	1		B
11-3	Meter Saw machine	1		C
11-4	Disc sanding Machine	1		C

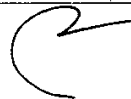

U₂

[Handwritten signature]

2-i. Mechanical Course Equipment

No.	Item	Q'ty	Remarks	Priority
12	CAD/CAM & Machine Design Lab.			
12-1	Computer	45		A
12-2	UPS	45		A
12-3	Desk	50		C
12-4	Laser Printer	2		C
12-5	Copy Machine	1		B
12-6	Muli Media Projector	1		B
12-7	CAD/CAM Software	50		B
12-8	Spring Test Equipment	2		B
12-9	Machine Design Simulation Software	1		B
12-10	Photo Elastic Unit	1		B
12-11	Machine Elements set	1		A
13	Drawing Hall			
13-1	Drawing Desk	150		C
13-2	Stool	150		C
14	Power Lab.			
14-1	Electrical Machine Trainer	2		B
14-2	Transformer Trainer	2		B
14-3	Circuit Breaker Trainer	2		B
14-4	Volt Meter DC/AC	10		B
14-5	Tester	10		C
14-6	Watt Meter DC/AC	10		C
14-7	Energy Meter	10		C
14-8	Megger	10		C
14-9	Multi Meter	10		B
14-10	Wire Gauge	20		B
14-11	Wire Polisher	20		C
14-12	Rotating and Balancing Stand	3		B
14-13	Wire Stripper	20		C
14-14	Induction Moter	5		C
14-15	Phase Sequence Meter	5		A
15	Electronics Lab.			
15-1	Semi Conductor Trainer	5		C
15-2	Industrial Electronics Trainer	5		B
15-3	PLC Trainer	5		B
15-4	Multi Meter	10		B
15-5	Curve Tracer	5		B
15-6	Regulator Power Supply	5		A
15-7	Oscilloscope	2		A
15-8	Function generator	2		A
16	Others			
16-1	White Board	15		C
16-2	Cabinet	15		C
16-3	Dust Box	15		C
16-4	Plastic Pallet	15		C
16-5	Steel Rack	15		C
16-6	Working Desk	15		C
16-7	Plastic Container	30		C
16-8	Safety Glass	50		C

2-1. Mechanical Course Equipment

No.	Item	Q'ty	Remarks	Priority
16-9	Helmet	50		C
16-10	Leather Glove	50		C
16-11	Apron	50		C
16-12	Blue Sheet	10		C
16-13	Stand Fan	10		C
16-14	Punching Pannel for Tools	10		C
16-15	Hand Cart	5		C
16-16	Hand Lifter	1		C
16-17	Hand Pallet Truck	1		C
16-18	Tool set	10		C
16-19	Plastic Bucket	10		C
16-20	Stool	50		C
16-21	Magnifing Glass	3		C
16-22	Loupe	5		A
16-23	Tool Box	20		B
16-24	Hand Vice	50		C
16-25	Table Vice	30		C
16-26	Drum Extension Chord	20		C
16-27	Halogen Light Stand	20		C







2-2. Architecture Course Equipment

No.	Item	Q'ty	Remarks	Priority
1	Architecture Computer Room			
1-1	Computer Work Station & UPS	80	15 were procured and repaired were 50, total 65 had been procured	B
1-2	Generator	1	Ditto	C
1-3	Plotter	1	Ditto	C
1-4	Printer	2	Ditto	C
1-5	Scanner	2	Ditto	C
1-6	Software	80	Lack of appropriate software	B
2	Multimedia Room			
2-1	Projector Set	1	Already procured	C
2-2	Meeting and Public Address Audio System	1		C
2-3	Table & Chairs	50	Already procured	C
3	Practical Training Workshop			
3-1	Amsler Type Material Testing Machine	2	Manual type	A
3-2	Concrete Test Standard Tool Set	1 unit		A
3-3	Repetition Material Testing Machine	1		C
3-4	Steel Work Tables & Chair	10	5 chairs for 1 table	C
4	Design Practice Workshop			
4-1	Drafting Table & Chair	130	130 were procured	C
5	Model Making Workshop			
5-1	Worktable & Chair	50		B
5-2	Tool Sets	1 unit		C
6	Furniture for New Building			
6-1	Educational use table & chair	1 unit	Related to number of the Students	A
6-2	Steel Cabinet	10		C
6-3	Office Table & Chair	20		C

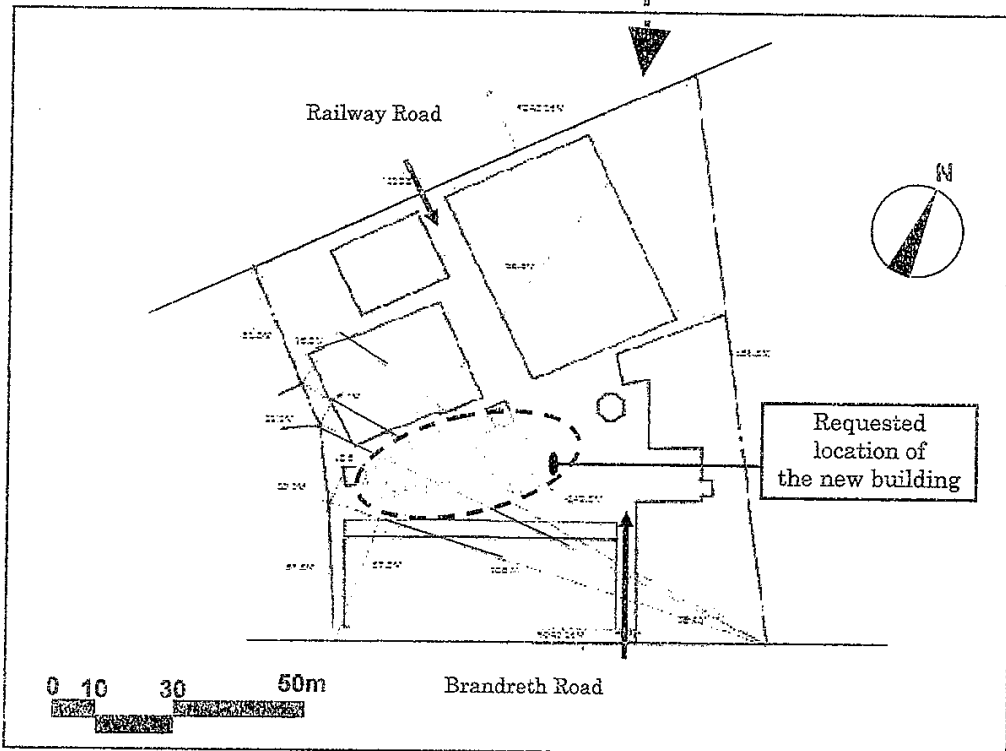
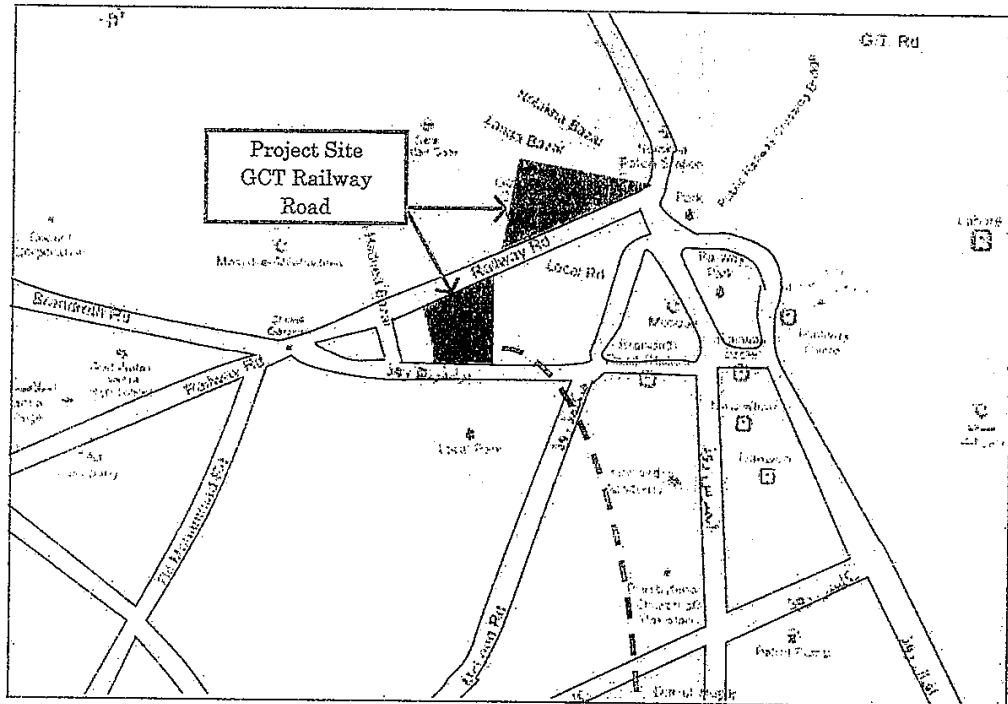
Project Site Location Map



R *U* *P* *M*

Japan's Grant Aid Scheme

The Government of Japan (hereinafter referred to as "the GOJ") is implementing the organizational reforms to improve the quality of ODA operations, and as a part of this realignment, a new JICA law was entered into effect on October 1, 2008. Based on this law and the decision of the GOJ, JICA has become the executing agency of the Grant Aid for General Projects, for Fisheries and for Cultural Cooperation, etc. The Grant Aid is non-reimbursable fund provided to a recipient country to procure the facilities, equipment and services (engineering services and transportation of the products, etc.) for its economic and social development in accordance with the relevant laws and regulations of Japan. The Grant Aid is not supplied through the donation of materials as such.

1. Grant Aid Procedures

The Japanese Grant Aid is supplied through following procedures:

- Preparatory Survey
 - The Survey conducted by JICA
- Appraisal & Approval
 - Appraisal by the GOJ and JICA, and Approval by the Japanese Cabinet
- Authority for Determining Implementation
 - The Notes exchanged between the GOJ and a recipient country
- Grant Agreement (hereinafter referred to as "the G/A")
 - Agreement concluded between JICA and a recipient country
- Implementation
 - Implementation of the Project on the basis of the G/A

2. Preparatory Survey

(1) Contents of the Survey

The aim of the preparatory Survey is to provide a basic document necessary for the appraisal of the Project made by the GOJ and JICA. The contents of the Survey are as follows:

- Confirmation of the background, objectives, and benefits of the Project and also institutional capacity of relevant agencies of the recipient country necessary for the implementation of the Project.
- Evaluation of the appropriateness of the Project to be implemented under the Grant Aid Scheme from a technical, financial, social and economic point of view.
- Confirmation of items agreed between both parties concerning the basic concept of the Project.
- Preparation of an outline design of the Project.
- Estimation of costs of the Project.

The contents of the original request by the recipient country are not necessarily approved in their initial form as the contents of the Grant Aid project. The Outline Design of the Project is confirmed based on the guidelines of the Japan's Grant Aid scheme.

JICA requests the Government of the recipient country to take whatever measures necessary to achieve its self-reliance in the implementation of the Project. Such measures must be guaranteed even though they may fall outside of the jurisdiction of the organization of the recipient country which actually implements the Project. Therefore, the implementation of the Project is confirmed by all relevant organizations of the recipient country based on the Minutes of Discussions.

(2) Selection of Consultants

For smooth implementation of the Survey, JICA employs (a) registered consulting firm(s). JICA selects (a) firm(s) based on proposals submitted by interested firms.

(3) Result of the Survey

JICA reviews the Report on the results of the Survey and recommends the GOJ to appraise the implementation of the Project after confirming the appropriateness of the Project.

3. Japan's Grant Aid Scheme

(1) The E/N and the G/A

After the Project is approved by the Cabinet of Japan, the Exchange of Notes(hereinafter referred to as "the E/N") will be signed between the GOJ and the Government of the recipient country to make a pledge for assistance, which is followed by the conclusion of the G/A between JICA and the Government of the recipient country to define the necessary articles to implement the Project, such as payment conditions, responsibilities of the Government of the recipient country, and procurement conditions.

(2) Selection of Consultants

In order to maintain technical consistency, the consulting firm(s) which conducted the Survey will be recommended by JICA to the recipient country to continue to work on the Project's implementation after the E/N and G/A.

(3) Eligible source country

Under the Japanese Grant Aid, in principle, Japanese products and services including transport or those of the recipient country are to be purchased. When JICA and the Government of the recipient country or its designated authority deem it necessary, the Grant Aid may be used for the purchase of the products or services of a third country. However, the prime contractors, namely, constructing and procurement firms, and the prime consulting firm are limited to "Japanese nationals".

Handwritten signatures and initials in black ink, including a large stylized signature, the initials 'Ua', a signature with a horizontal line, and the initials 'Jh'.

(4) Necessity of "Verification"

The Government of the recipient country or its designated authority will conclude contracts denominated in Japanese yen with Japanese nationals. Those contracts shall be verified by JICA. This "Verification" is deemed necessary to fulfill accountability to Japanese taxpayers.

(5) Major undertakings to be taken by the Government of the Recipient Country

In the implementation of the Grant Aid Project, the recipient country is required to undertake such necessary measures as Annex.

(6) "Proper Use"

The Government of the recipient country is required to maintain and use properly and effectively the facilities constructed and the equipment purchased under the Grant Aid, to assign staff necessary for this operation and maintenance and to bear all the expenses other than those covered by the Grant Aid.

(7) "Export and Re-export"

The products purchased under the Grant Aid should not be exported or re-exported from the recipient country.

(8) Banking Arrangements (B/A)

- a) The Government of the recipient country or its designated authority should open an account under the name of the Government of the recipient country in a bank in Japan (hereinafter referred to as "the Bank"). JICA will execute the Grant Aid by making payments in Japanese yen to cover the obligations incurred by the Government of the recipient country or its designated authority under the Verified Contracts.
- b) The payments will be made when payment requests are presented by the Bank to JICA under an Authorization to Pay (A/P) issued by the Government of the recipient country or its designated authority.

(9) Authorization to Pay (A/P)

The Government of the recipient country should bear an advising commission of an Authorization to Pay and payment commissions paid to the Bank.

(10) Social and Environmental Considerations

A recipient country must carefully consider social and environmental impacts by the Project and must comply with the environmental regulations of the recipient country and JICA socio-environmental guidelines.

The image shows four handwritten signatures or initials in black ink. From left to right: a large, stylized signature; a smaller signature; a signature with a long horizontal line extending to the right; and a signature that appears to be 'SL'.

FLOW CHART OF JAPAN'S GRANT AID PROCEDURES

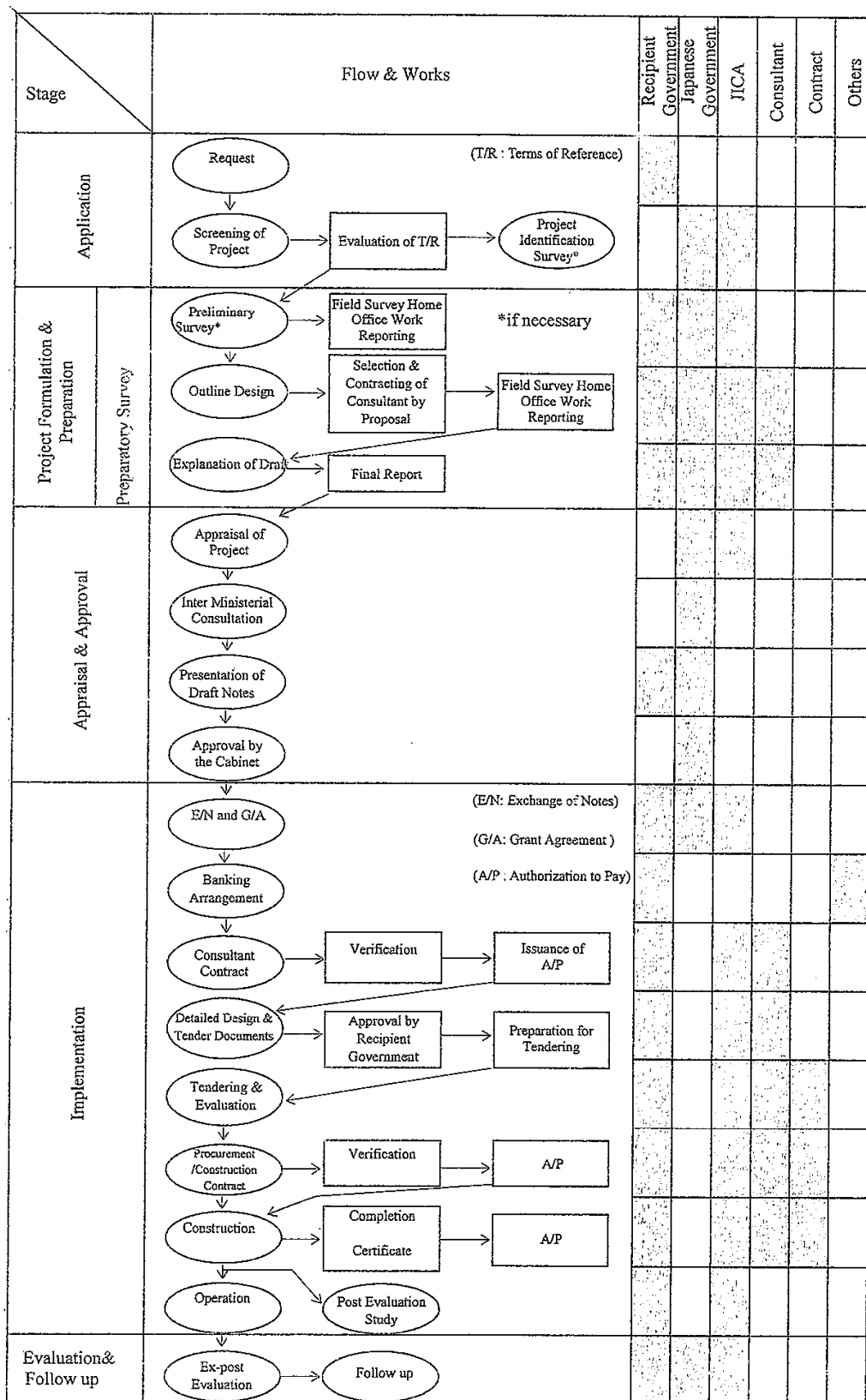

Major Undertakings to be taken by Each Government

No.	Items	To be covered by Grant Aid	To be covered by Recipient Side
1	To secure a lot of land and appropriate access road from the main road necessary for the implementation of the Project and to clear the site.		Ⓐ
2	To construct the following facilities		
	1) The building	Ⓐ	
	2) The gates and fences in and around the site		Ⓐ
	3) The parking lot		Ⓐ
	4) The road within the site	Ⓐ	
	5) The road outside the site		Ⓐ
3	To provide facilities for distribution of electricity, water supply and drainage and other incidental facilities necessary for the implementation of the Project outside the site.		
	1) Electricity		
	a. The distributing power line to the site		Ⓐ
	b. The drop wiring and internal wiring within the site	Ⓐ	
	c. The main circuit breaker and transformer	Ⓐ	
	2) Water Supply		
	a. The city water distribution main to the site		Ⓐ
	b. The supply system within the site (receiving and elevated tanks)	Ⓐ	
	3) Drainage		
	a. The city drainage main (for storm sewer and others to the site)		Ⓐ
	b. The drainage system (for toilet sewer, common waste, storm drainage and others) within the site	Ⓐ	
	4) Gas Supply		
	a. The city gas main to the site		Ⓐ
	b. The gas supply system within the site	Ⓐ	
	5) Telephone System		
	a. The telephone trunk line to the main distribution frame/panel (MDF) of the building		Ⓐ
	b. The MDF and the extension after the frame/panel	Ⓐ	
	6) Furniture and Equipment		
	a. General furniture		Ⓐ
	b. Project equipment	Ⓐ	
4	To ensure prompt unloading and customs clearance of the products at ports of disembarkation in the recipient country and to assist internal transportation of the products in the recipient country.		
	1) Marine (Air) transportation of the Products from Japan to the recipient country	Ⓐ	
	2) Tax exemption and custom clearance of the Products at the port of disembarkation		Ⓐ
	3) Internal transportation from the port of disembarkation to the project site	Ⓐ	(Ⓐ)
5	To ensure that customs duties, Value added Tax, any other taxes and fiscal levies charges which may be imposed in the recipient country with respect to the purchase of the products and the services be exempted.		Ⓐ
6	To accord Japanese nationals whose services may be required in connection with the supply of the products and the services such facilities as may be necessary for their entry into the recipient country and stay therein for the performance of their work		Ⓐ
7	To ensure that the Facilities, the products and the equipment be maintained and used properly and effectively for the implementation of the Project		Ⓐ
8	To bear all the expenses, other than those covered by the Grant, necessary for the implementation of the Project		Ⓐ
9	To bear the following commissions paid to the Japanese bank for banking services based upon the B/A		
	1) Advising commission of A/P		Ⓐ
	2) Payment commission		Ⓐ
10	To give due environmental and social consideration in the implementation of the Project.		Ⓐ

(B/A : Banking Arrangement, A/P : Authorization to pay)

4-2 討議議事録 (概要説明調査時)

MINUTES OF DISCUSSIONS
ON
THE PREPARATORY SURVEY (BASIC DESIGN)
ON THE PROJECT FOR STRENGTHENING OF DAE MECHANICAL &
ARCHITECTURE DEPARTMENTS IN GCT RAILWAY ROAD
OF PUNJAB PROVINCE
(EXPLANATION OF THE DRAFT REPORT)

In response to the request from the Government of Pakistan (hereinafter referred to as "GOP"), the Government of Japan decided to conduct the Preparatory Study for the Project for Strengthening of DAE Mechanical & Architecture Departments in GCT Railway Road of Punjab Province (hereinafter referred to as "the Project") and entrusted the study to the Japan International Cooperation Agency (hereinafter referred to as "JICA").

JICA sent to the Pakistan Preparatory Survey Team (hereinafter referred to as "the Team"), headed by Mr. Toshiya Sato, Senior Representative, JICA Pakistan Office, and is scheduled to stay in the country from 13th February to 23rd February, 2011.

In the course of discussions, both parties have confirmed the main items described in the attached sheets.

Lahore, February 17, 2011

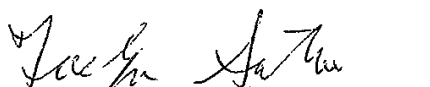

Mr. Toshiya Sato
Senior Representative
Pakistan Office
Japan International Cooperation Agency

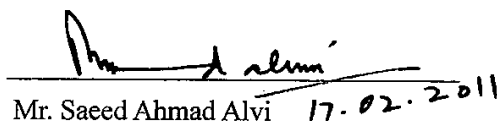

17.02.2011

Mr. Saeed Ahmad Alvi
Chairperson
Technical Education and Vocational
Training Authority, Punjab



Mr. Ali Tahir 17/2/11
Secretary
Planning and Development Department
Government of the Punjab

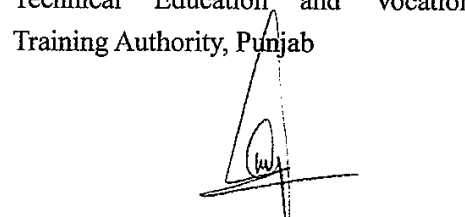

Mr. Waqar Hussain Abbasi
Deputy Secretary
Economic Affairs Division
Government of Pakistan

ATTACHMENT

1: Objective of the Project

The objective of the Project is to improve the capacity of Mechanical and Architecture Departments of Government College of Technology Railway Road Lahore (hereinafter referred to as "GCT Railway") through construction of Architecture building and improving the necessary equipments of Mechanical and Architecture Departments.

2. Responsible and Implementing Agency

2.1. The Counterpart Ministry is Economic Affairs Division, Ministry of Economic Affairs and Statistics.

2.2. The Responsible Agency is Government of the Punjab Province through Technical Education and Vocational Training Authority (hereinafter referred to as "TEVTA").

2.3. The Implementing and Executing Agency is TEVTA, Punjab.

3. Components of the Draft Final Report

The Pakistani side has agreed and accepted in principle the contents of the draft final report explained by the Team, the facility construction plan, the list of equipments described in Annex-1 and -2.

4. Japan's Grant Aid Scheme

4-1. GOP understood the Japan's Grant Aid Scheme explained by the Team, as described in Annex-3 and -4.

4-2. GOP will take the necessary measures, as described in Annex-5, for smooth implementation of the Project, as a condition for the Japanese Grant Aid to be implemented.

5. Schedule of the Study

JICA will complete a final report based upon the findings of this survey and send it to Pakistan by around May, 2011.

6. Confidentiality of the Project

Both sides agreed that the contents of the draft report would be kept confidential, be dealt with carefulness and will not be disclosed to any third parties.

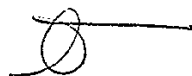

7. Confidentiality of the Project Cost Estimation

Both sides agreed that the Project Cost Estimation should never be duplicated or released to any outside parties before signing of all the Contracts for the Project. The Pakistani side understood that the Project Cost Estimation attached as Annex-6 is not final and is subject to change.

8. PC-1 Procedure

The Pakistani side agreed to complete the PC-1 procedure within April 2011 in coordination among the concerned parties at the Federal and Provincial government level.

9. Manipulation training

Manipulation training on how to operate equipments will be provided by Japanese contractors upon their installation.

Annex-1: Facility construction plan

Annex-2: Equipment List

Annex-3: Japan's Grant Aid Scheme

Annex-4: Flow Chart of Japan's Grant Aid Procedures

Annex-5: Major Undertakings by each Government

Annex-6: Project Cost Estimation

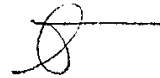

Facility construction plan

1. Outline of the facility

(1) Purpose of the building

- Architecture course practical education lecture building

(2) Number of stories and floor area

(Floor)	(Floor area, approx.)
- Penthouse	76.5 m ²
- Second floor	644.0 m ²
- First floor	644.0 m ²
- Ground floor	634.0 m ²
- Basement floor	126.5 m ²
Total	Approx. 2,125.0 m ²

(3) Building structure type

- The main building frame (foundation, beams, columns, slabs) are planned by RC rahmen type structure and main walls are designed by brick masonry.

2. Overview of main rooms

Table Overview main rooms

Room category	No. of rooms	Primary function	Design no. of users	Floor area Approx.(m ²)
Learning/training department				
Design drawing room	2	Practical design drawing training utilizing drafting boards.	45 students + instructor	103
CAD laboratory	2	Practical design drawing training using CAD.	Same as above	103
Standard training room (Theory class)	2	Seated practical training.	Same as above	51
Multipurpose laboratory	1	Material testing; simulated practice in producing RC.	Same as above	180
Server/printing room	2	PC server, printer, storage space.	2~3	8
Preparation room of Multipurpose laboratory	1	Preparation for practical training equipment and student's lockers	To be determine on the basis of quantity of materials and equipment	25
Drawing room storage	1	Storage for design drawing equipment, and modeling materials.	Same as above	21

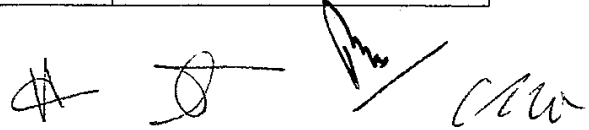

Multipurpose laboratory material storage	4	Storage for practical training materials.	Same as above	6
Survey / measurement equipment storage	1	Storage for survey / measurement equipment.	Same as above	30
Administrative department				
Instructors' room (with Teacher's training functions)	1	This is to be a single large room, equipped with desks and chairs, with private consultation corners and visitor corners that can be set off by movable partitions.	14~20	103
Administrative office	1	Reception; security (2 persons at all times, 3 shifts per day).	2	12
Administrative department rooftop storage	1	Storage for administrative documents and materials.	To be determined on the basis of quantity of materials and equipment	
Female student support department				
Common room	1	Room for female student self study and relaxation (capable of accommodating half the female enrollment at one time).	96/2=48	51
Locker room	1	Lockers to secure hand-carried articles. (aimed at accommodating all female students, both for morning classes and afternoon classes)	96×2=192	12
Dispensary/rest area	1	Rest space (1person+1 nurse staff).	2	8
2 nd floor women's lavatory	1	Women only lavatory (for use by both female students and female staff).	5 toilet units	
Common facilities				
Entrance hall	1set	Common entrance way.	—	
Hallways	1set	2 corridors are necessary to ensure efficient instructor and student movement flow lines.	—	Width: 2.3m
Stairways	2	2 stairway locations are necessary to connect floors as well as provide escaped routes in case of emergency.		Width: 1.4/1.5m
Multipurpose use areas	1	For relaxation; displays; meetings, etc.	20~30	50
1 st floor men's lavatory	1	For visitors and instructors.	Single person use	—
1 st floor women's lavatory	1	For visitors and instructors.	Same as above	—
1 st floor multipurpose lavatory	1	Wheelchair enabled.	Same as above	—
2 nd floor instructors' lavatory (male)	1	Instructors/staff.	Two person use	—
3 rd floor male students' lavatory	1	Male student lavatory.	4 toilet bowel units; 4 urinal units	
Kitchenette (Ground & First floor)	2	Hot water for tea service (for staff).	Single person use	—
Appurtenant facilities				
Electrical panel room (generator room)	1	Electrical distribution panel, generator.	To be determined on the bases of equipment layout	—
Water receiving tank (pump room)	1	Water receiving tank, pump.	Same as above	—
Elevated water tank (rooftop)	1set	Elevated water tank.	Same as above	—
Water treatment tank	1set	Integrated treatment tank	Same as above	—
Outdoor facilities	1set	Outdoor facilities (parking lot, access walkway, planting, etc.) around the building; access road, etc.		—



Equipment List (1/3)

Annex-2

No.	Equipment Number of related Labo/ Workshop	Equipment Name	Qty
1	M- 1- 1 M- 2- 1	Lathe Machine	9
2	M- 1- 2	Bench Type Drilling Machine	2
3	M- 2- 2	Hobbing Machine	1
4	M- 2- 3	Universal Milling Machine	2
5	M- 2- 4	Shaper	1
6	M- 2- 5	Surface Grinder	1
7	M- 2- 6	Universal Tool and Cutter Grinder	1
8	M- 2- 7 M- 3- 1	Micrometer	15
9	M- 2- 8 M- 3- 3 M- 6- 13	Digital Caliper	20
10	M- 3- 2	Anvil Micrometer	5
11	M- 3- 4	Digital Pitch Caliper	5
12	M- 3- 5	Dial Indicator	10
13	M- 3- 6	Digital Depth Gauge	10
14	M- 3- 7	Digital Height Gauge	5
15	M- 3- 9	Dial Caliper	5
16	M- 3- 10	Dial Bore Gauge	3
17	M- 3- 11	Dial Caliper Gauge	3
18	M- 3- 17	Inner Micrometer	3
19	M- 3- 18	Groove Width Caliper	3
20	M- 3- 19	Mechanical Comparator	2
21	M- 3- 20	Electrical Comparator	2
22	M- 3- 21	Engineering Microscope	2
23	M- 3- 22	Depth Gauge	10
24	M- 3- 25	Steel Surface Plate	4
25	M- 3- 26	Snap Gauge set	10
26	M- 3- 27	Ring Gauge set	2
27	M- 3- 28	Thread Ring Gauge	5
28	M- 3- 29	Protractor	10
29	M- 3- 34	Point Micrometer	5
30	M- 3- 36	Depth Micrometer	4
31	M- 3- 41	Radius Gauge	5
32	M- 3- 42	Screw Pit Gauge	10
33	M- 3- 44	Universal Gear Inspection Equipment	1
34	M- 3- 45	Digital Gauge Tester	1
35	M- 3- 46	Taper Gauge	3
36	M- 3- 47	Pararell Bar	10
37	M- 3- 48	Surface Roughness Standard Piece	2
38	M- 3- 49	Drill Gauge	2
39	M- 3- 50	Square VBlock	5
40	M- 4- 1	Arc Welding Machine	6
41	M- 4- 2	TIG Welding Machine	2
42	M- 4- 3	MAG Welding Machine	2
43	M- 4- 4	Plasma Cutting Machine	1
44	M- 4- 6	Forging Furnace	5
45	M- 4- 7 M- 5- 14 M- 7- 13	Pedestal Grinder	3
46	M- 4- 8	Gas Mani Fold System	1

[Handwritten signatures and initials]

Equipment List (2/3)

No.	Equipment Number of related Labo/ Workshop	Equipment Name	Qty
47	M- 4- 9	Oxygen Gas Cylinder	5
48	M- 4- 10	Acetylene Gas Cylinder	5
49	M- 4- 11	Oxy-Acetylene Gas Cutting Torch	5
50	M- 4- 12	Oxy-Acetylene Gas Welding Torch	5
51	M- 4- 18	Hand Vice	30
52	M- 4- 20	Welding Shield	20
53	M- 4- 24 M- 5- 15	Air Compressor	2
54	M- 4- 30	Cylinder Rack	4
55	M- 4- 31	Handy Disc Grinder	5
56	M- 5- 1	Tilting Crucible Furnace	1
57	M- 5- 3	Jolt Squeeze Molding Machine	1
58	M- 5- 4	Sand Milling Machine	1
59	M- 5- 5	Permeability Meter	1
60	M- 5- 6	Mold Tester	1
61	M- 5- 7	Pyrometer	2
62	M- 5- 11	Crucible	8
63	M- 5- 12	Mold Box	8
64	M- 5- 13	Power Riddle Machine	1
65	M- 5- 16	Air Blower	2
66	M- 5- 17	Air Gun	5
67	M- 6- 5	Power Hack Saw	2
68	M- 6- 6	Disc Cutter	2
69	M- 6- 7	Manual Sheet Bending Machine	2
70	M- 6- 8	Manual Sheet Rolling Machine	2
71	M- 6- 9	Manual Sheet Shearing Machine	2
72	M- 6- 10	Handy Drilling Machine	2
73	M- 6- 12 9- 13	Micrometer	6
74	M- 6- 14	Surface Plate for Sheet Metal	4
75	M- 6- 15	Lever Shear	5
76	M- 7- 1	Brinnell Hardness Testing Machine	1
77	M- 7- 2	Rockwell Hardness Testing machine	1
78	M- 7- 8	Metallurgical Microscope	1
79	M- 7- 9	Torsion Testing Machine	1
80	M- 7- 10	Rotation Fatigue Testing Machine	1
81	M- 7- 11	Electric Annealing Furnace	1
82	M- 7- 12	Hardening and Quenching Bath	1
83	M- 7- 14	Ultrasonic Detecting Equipment	1
84	M- 8- 1	Fluid Friction Apparatus	2
85	M- 8- 2	Venturi Meter Apparatus	1
86	M- 8- 3	Bernoulli's Theorem Demonstration Apparatus	1
87	M- 8- 4	Orifice Flow Apparatus	1
88	M- 8- 5	Apparatus of Energy Losses in Bends	1
89	M- 8- 6	Centrifugal Pump Apparatus	1
90	M- 8- 7	Axial Pump Apparatus	1
91	M- 8- 8	Piston Pump Apparatus	1
92	M- 8- 9	Pelton Turbine	1
93	M- 8- 10	Axial Flow Turbine	1

[Handwritten signatures and initials]

Equipment List (3/3)

No.	Equipment Number of related Labo/ Workshop	Equipment Name	Qty
94	M- 8- 11	Francis Turbine	1
95	M- 8- 12	Radial Flow Turbine	1
96	M- 8- 13	Hydraulic Equipment Set	2
97	M- 8- 14	Hydraulic Bench	1
98	M- 8- 15	Axial Pump (Sectional Cut Model)	1
99	M- 8- 16	Ball Valve (Sectional Cut Model)	1
100	M- 8- 17	Vane Pump (Sectional Cut Model)	1
101	M- 8- 18	Piston Pump (Sectional Cut Model)	1
102	M- 8- 19	Digital Length Measuring Equipment	1
103	M- 9- 1	Vertical Machining Center	1
104	M- 9- 2	Turning Center	1
105	M- 9- 3	CNC Wire Cut	1
106	M- 9- 7	Robotics Equipment Kit	1
107	M- 9- 10	DVD Video for mold making and molding	2
108	M- 9- 11	Manual Injection Molding machine	2
109	M- 9- 12	Pneumatic Equipment Set	2
110	M- 9- 15	Surface Gauge	5
111	M- 9- 16	Steel Surface Plate	1
112	M- 9- 17	Depth Guage	3
113	M- 10- 8	Ignition Point Testing Machine	1
114	M- 10- 9	Air Compressor Testing Machine	1
115	M- 10- 10	Gas Turbine Testing Machine	1
116	M- 10- 12	Steam Boiler Experiment Appratus	1
117	M- 11- 1	Wood Turning Lathe	1
118	M- 11- 2	Band Saw Machine	1
119	M- 12- 6	Multi Media Projector	1
120	M- 12- 8	Spring Test Equipment	2
121	M- 12- 11	Machine Elements set	1
122	M- 14- 1	Electrical Machine Trainer	2
123	M- 14- 2	Transformer Trainer	2
124	M- 14- 3	Circuit Breaker Trainer	2
125	M- 14- 4	Volt Meter DC/AC	10
126	M- 14- 9 15- 4	Multi Meter	20
127	M- 14- 10	Wire Gauge	20
128	M- 14- 15	Phase Sequence Meter	5
129	M- 15- 2	Industrial Electronics Trainer	5
130	M- 15- 3	PLC Trainer	5
131	M- 15- 5	Curve Tracer	5
132	M- 15- 6	Regulator Power Supply	5
133	M- 15- 7	Oscilloscope	2
134	M- 15- 8	Function generator	2
135	M- 16- 22	Loupe	5
136	M- 16- 23	Tool Box	20
137	A- 3- 1	Portable Compression Testing Machine	2
138	A- 3- 2	Concrete Test Standard Tool Set	1
139	A- 3- 3	Hand Pallet Truck	2
140	A- 3- 4	Pallet	8
141	A- 3- 5	White Board	2

[Handwritten signatures and initials]

JAPAN'S GRANT AID

The Government of Japan (hereinafter referred to as “the GOJ”) is implementing the organizational reforms to improve the quality of ODA operations, and as a part of this realignment, a new JICA law was entered into effect on October 1, 2008. Based on the law and the decision of the GOJ, JICA has become the executing agency of the Grant Aid for General Projects.

The Grant Aid is non-reimbursable fund to a recipient country to procure the facilities, equipment and services (engineering services and transportation of the products, etc.) for economic and social development of the country under principles in accordance with the relevant laws and regulations of Japan. The Grant Aid is not supplied through the donation of materials as such.

1. Grant Aid Procedures

The Japanese Grant Aid is conducted as follows-

- Preparatory Survey (hereinafter referred to as “the Survey”)
 - The Survey conducted by JICA
- Appraisal & Approval
 - Appraisal by The GOJ and JICA, and Approval by the Japanese Cabinet
- Determination of Implementation
 - The Notes exchanged between the GOJ and a recipient country
- Grant Agreement (hereinafter referred to as “the G/A”)
 - Agreement concluded between JICA and a recipient country
- Implementation
 - Implementation of the Project on the basis of the G/A

2. Preparatory Survey

(1) Contents of the Survey

The aim of the Survey is to provide a basic document necessary for the appraisal of the Project by JICA and the GOJ. The contents of the Survey are as follows:

- Confirmation of the background, objectives, and benefits of the Project and also

institutional capacity of agencies concerned of the recipient country necessary for the implementation of the Project.

- Evaluation of the appropriateness of the Project to be implemented under the Grant Aid Scheme from a technical, financial, social and economic point of view.
- Confirmation of items agreed on by both parties concerning the basic concept of the Project.
- Preparation of a basic design of the Project.
- Estimation of costs of the Project.

The contents of the original request by the recipient country are not necessarily approved in their initial form as the contents of the Grant Aid project. The Basic Design of the Project is confirmed considering the guidelines of the Japan's Grant Aid scheme.

JICA requests the Government of the recipient country to take whatever measures are necessary to ensure its self-reliance in the implementation of the Project. Such measures must be guaranteed even though they may fall outside of the jurisdiction of the organization in the recipient country actually implementing the Project. Therefore, the implementation of the Project is confirmed by all relevant organizations of the recipient country through the Minutes of Discussions.

(2) Selection of Consultants

For smooth implementation of the Survey, JICA uses (a) registered consulting firm(s). JICA selects (a) firm(s) based on proposals submitted by interested firms.

(3) Result of the Survey

The Report on the Survey is reviewed by JICA, and after the appropriateness of the Project is confirmed, JICA recommends the GOJ to appraise the implementation of the Project.

3. Japan's Grant Aid Scheme

(1) The E/N and the G/A

After the Project is approved by the Cabinet of Japan, the E/N will be signed between the GOJ and the Government of the recipient country to make a plea for assistance,



which is followed by the conclusion of the G/A between JICA and the Government of the recipient country to define the necessary articles to implement the Project, such as payment conditions, responsibilities of the Government of the recipient country, and procurement conditions.

(2) Selection of Consultants

The consultant firm(s) used for the Survey will be recommended by JICA to the recipient country to also work on the Project's implementation after the E/N and the G/A, in order to maintain technical consistency.

(3) Eligible source country

Under the Japanese Grant Aid, in principle, Japanese products and services including transport or those of the recipient country are to be purchased. When JICA and the Government of the recipient country or its designated authority deem it necessary, the Grant Aid may be used for the purchase of the products or services of a third country. However, the prime contractors, namely, constructing and procurement firms, and the prime consulting firm are limited to "Japanese nationals". (The term "Japanese nationals" means persons of Japanese nationality or Japanese corporations controlled by persons of Japanese nationality.)

(4) Necessity of "Verification"

The Government of recipient country or its designated authority will conclude contracts denominated in Japanese yen with Japanese nationals. Those contracts shall be verified by JICA. This "Verification" is deemed necessary to secure accountability to Japanese taxpayers.

(5) Major undertakings to be taken by the Government of the Recipient Country

In the implementation of the Grant Aid Project, the recipient country is required to undertake such necessary measures as Annex-5.

(6) "Proper Use"

The Government of recipient country is required to maintain and use the facilities constructed and the equipment purchased under the Grant Aid properly and effectively and to assign staff necessary for this operation and maintenance as well as to bear all the expenses other than those covered by the Grant Aid.

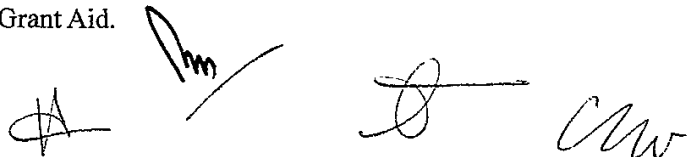

(7) "Export and Re-export"

The products purchased under the Grant Aid should not be exported or re-exported from the recipient country.

(8) Banking Arrangements (B/A)

- a) The Government of the recipient country or its designated authority should open an account in the name of the Government of the recipient country in a bank in Japan (hereinafter referred to as "the Bank"). JICA will execute the Grant Aid by making payments in Japanese yen to cover the obligations incurred by the Government of the recipient country or its designated authority under the Verified Contracts.
- b) The payments will be made when payment requests are presented by the Bank to JICA under an Authorization to Pay (A/P) issued by the Government of the recipient country or its designated authority.

(9) Authorization to Pay (A/P)

The Government of the recipient country should bear an advising commission of an Authorization to Pay and payment commissions to the Bank.

(10) Social and Environmental Considerations

A recipient country must ensure the social and environmental considerations for the Project and must follow the environmental regulation of the recipient country and JICA socio-environmental guidelines.

Am (End)

CA J CW

FLOW CHART OF JAPAN'S GRANT AID PROCEDURES

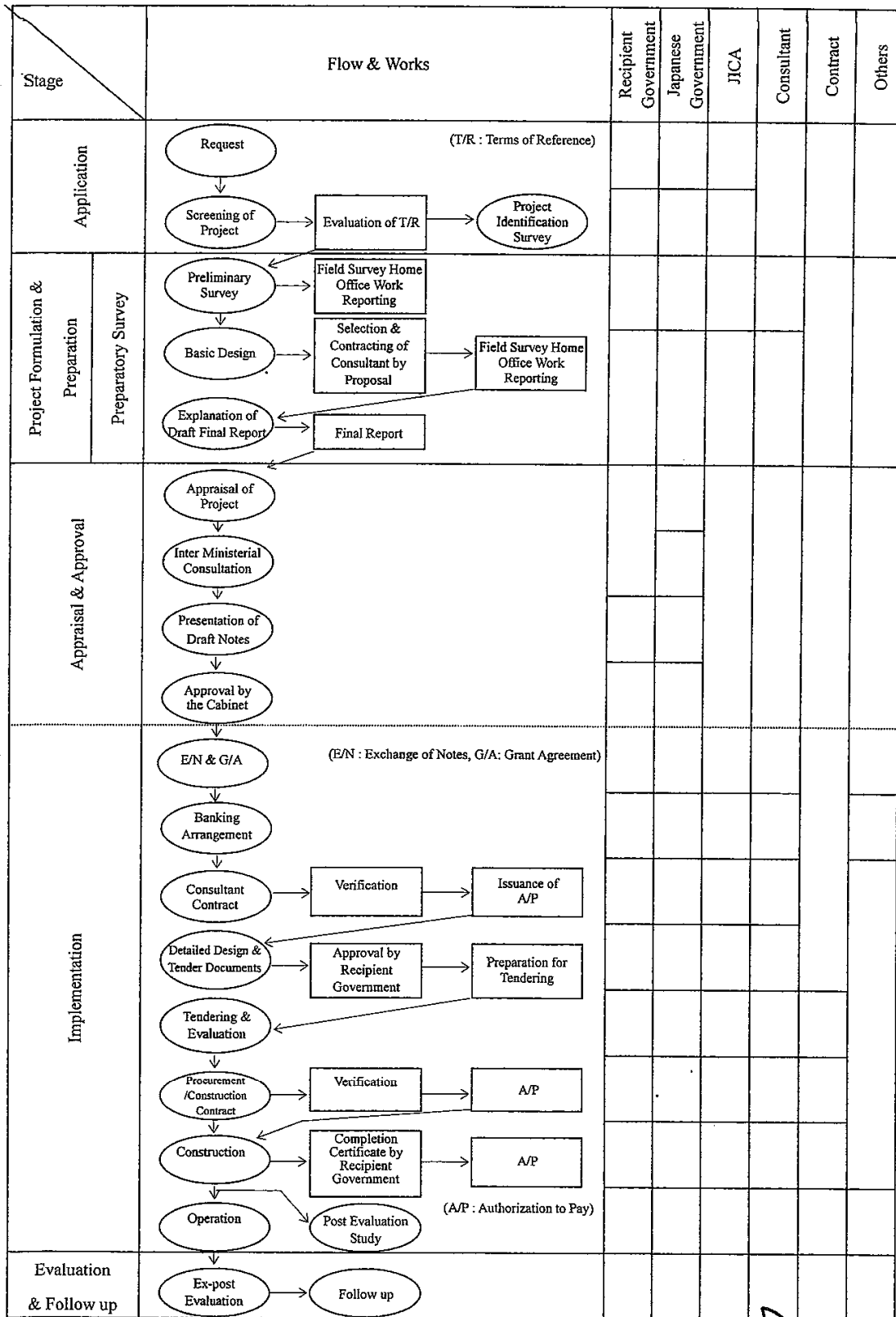

Major Undertakings by Each Government

1. Work content covered by Grant Aid and Recipient Side

Work content	To be covered by Grant Aid	To be covered by Recipient Side	Schedule
1. Land acquisition		○	A
2. Moving or dismantling obstructions within the construction area and land preparation (removal/relocation of trees and other vegetation, existing well, buried objects, obstructing infrastructure, etc.)		○	A
3. Acquisition access and temporary construction facility area (dismantling of obsolete facilities, land preparation, removal of obstacles to south-side access, etc.); garden planting after construction completion; installation of compound wall and gate.		○	A
4. Ensuring safe movement flow lines for area residents during construction (constructing a west-side wall and ensuring a safe walk route from the men's dormitory to the mosque)		○	A
5. Facility construction			
• Construction of design building and facilities; design equipment procurement and installation works	○		B
• Parking area within the construction site (south-side access; temporary construction facility area)	○		B
• Parking space outside the Project construction area (north-side TT building and east-side of Jubilee Hall)		○	B
• Fences, gates and gate house		○	B
6. Necessary permit and authorization applications for construction, including related application costs		○	A
7. Public infrastructure lead-in works to the site			
1) Power			
• Application for power reception including from the existing main power line via a newly to be installed transformer		○	B
• Installation of a transformer with necessary capacity for the Project facilities; underground electrical line from the transformer to the power receiving panel.	○		B
2) Water supply			
• Water pipe connection from the relocated well to the Project building water receiving tank		○	B
• Project facility water supply system (water receiving tank; pump)	○		B
3) Drainage			
• Main drainage pipeline (rehabilitation of the existing drainage pipeline and collection pits)		○	B
• Drainage system for Project facilities and immediate surrounding area (contaminated effluent, miscellaneous drainage water, rain runoff drainage, etc.)	○		B
4) Gas			
• Gas canister installation and gas pipe extension and connection to feed Project building kitchenettes		○	B
5) Telephone / LAN			
• Telephone mainline lead-in to the Project building MDF		○	B
• Unwired conduit installation for MDF and telephone connection and LAN use	○		B

Am
Alw

6) Furniture, fittings and fixtures (desks, chairs, curtains, blinds, cabinets, etc.)			
• Design equipment (classroom/laboratory desks and chairs)	○		B
• Furniture, fittings and fixtures outside the scope of design equipment		○	B
8. Commission costs set out below with regard to a Japanese foreign exchange bank based on the approved bank agreement (B/A).			
• Advisory commission for authorization to pay (A/P) documentation		○	C
• Payment commission		○	C
9. Import and customs procedures			
1) Sea shipping cost to Pakistan	○		C
2) Tax exemption and expediting customs procedures after cargo unloading		○	C
3) Inland transportation and unloading on site	○		C
4) Expediting procedure for inland transportation and unloading on site		○	C
10. Expediting Japanese expert entry and exit from Pakistan in conjunction with Project works, as well as expediting procedures related to Japanese expert stay in Pakistan		○	C
11. Exemption of Japanese experts from Pakistan customs duties, domestic taxes and income tax during assignment in Pakistan		○	C

Remarks:

A: Items to be completed before the start of the construction

B: Items to be completed before the completion of the construction

C: Items to be taken care of in the course of the project implementation

Handwritten signatures and initials: A stylized 'A', a signature that appears to be 'Ahm', another signature, and the initials 'C/W'.

5. 参考資料

番号	名称	形態 図書・ビデオ 地図・写真等	オリジナル ・コピー	発行機関	発行年
1	PC-1 FOR STRENGTHENING OF DAE MECHANICAL & ARCHITECTURE DEPARTMENT IN GOVT. COLLEGE OF THE TECHNOLOGY, RAILWAY ROAD LAHORE	図書	コピー	TEVTA, PANJAB	2011
2	NOTIFICATION OF GOVT. COLLEGE OF THE TECHNOLOGY, RAILWAY ROAD LAHORE	図書	コピー	TEVTA, PANJAB	2008
3	PROSPECTUS 2010-2011 OF GOVT. COLLEGE OF THE TECHNOLOGY, RAILWAY ROAD LAHORE	図書	コピー	GOVT. COLLEGE OF THE TECHNOLOGY, RAILWAY ROAD LAHORE AND TEVTA, PANJAB	2010
4	ILO/SKILLS-AP/JAPAN REGIONAL TECHNICAL MEETING ON DEVELOPING NATIONAL SKILLS STRATEGIES	図書	コピー	ILO	2007
5	SUMMARY OF THE FEDERAL BUDGET 2010-11	図書	コピー	FINANCE DIVISION OF GOVERNMENT OF PAKISTAN	2010
6	YEAR BOOK 2008-2009	図書	コピー	FINANCE DIVISION OF GOVERNMENT OF PAKISTAN	2009
7	ANNUAL BUDGET STATEMENT 2010-2011	図書	コピー	GOVERNMENT OF PUNJAB	2010
8	WHITE PAPER 2010-2011	図書	コピー	Ditto	2010
9	REPORT ON MONITORING AND EVALUATION FOR 1 st YEAR PILOT AND OTHER COURSES DAE ARCHITECTURE TECHNOLOGY AND DAE MECHANICAL TECHNOLOGY	図書	コピー	JICA PROJECT OFFICE OF GCT RAILWAY ROAD AND TEVTA	2010
10	MAJOR FINDING IN THE TNA (TRAINING NEEDS ASSESMENT) CONDUCTED BY GCT RAILWAY ROAD	図書	コピー	Ditto	2009
11	Pakistan Building Code BCP SP-2007	図書	コピー	GOVERNMENT OF PAKISTAN	2007
12	MODEL BUILDING AND ZONING BY LAWS FOR TOWN MUNICIPAL ADMINISTRATIONS IN PUNJAB	図書	コピー	LOCAL GOVERNMENT & COMMUNITY DEVELOPMENT DEPARYMENT GOVERNMENT OF PANJYAB	2007
13	ABRIDGED CONDITION OF SUPPLY (WATER AND ELECTRICITY)	図書	コピー	WATER AND POWER DEVELOPMENT AUTHORITY	2010
14	WEATHER DATA	図書	コピー	LAHORE AIR PORT	2010
15	世界の統計 2010	図書	コピー	総務省、統計局	2010
16	機械学科修正中カリキュラム	図書	コピー	Ditto	2009
17	建築学科修正中カリキュラム	図書	コピー	Ditto	2009
16	パキスタン国技術改善プロジェクト実施協議報告書	図書	コピー	JICA	2009
18	パキスタン国技術教育・訓練プロジェクト形成調査報告書	図書	コピー	Ditto	2007
19	パキスタン国民間セクター活性化のための産業強化調査ファイナルレポート	図書	コピー	Ditto	2006

[資 料-2]

1. サイト測量図
 - (1) 境界図

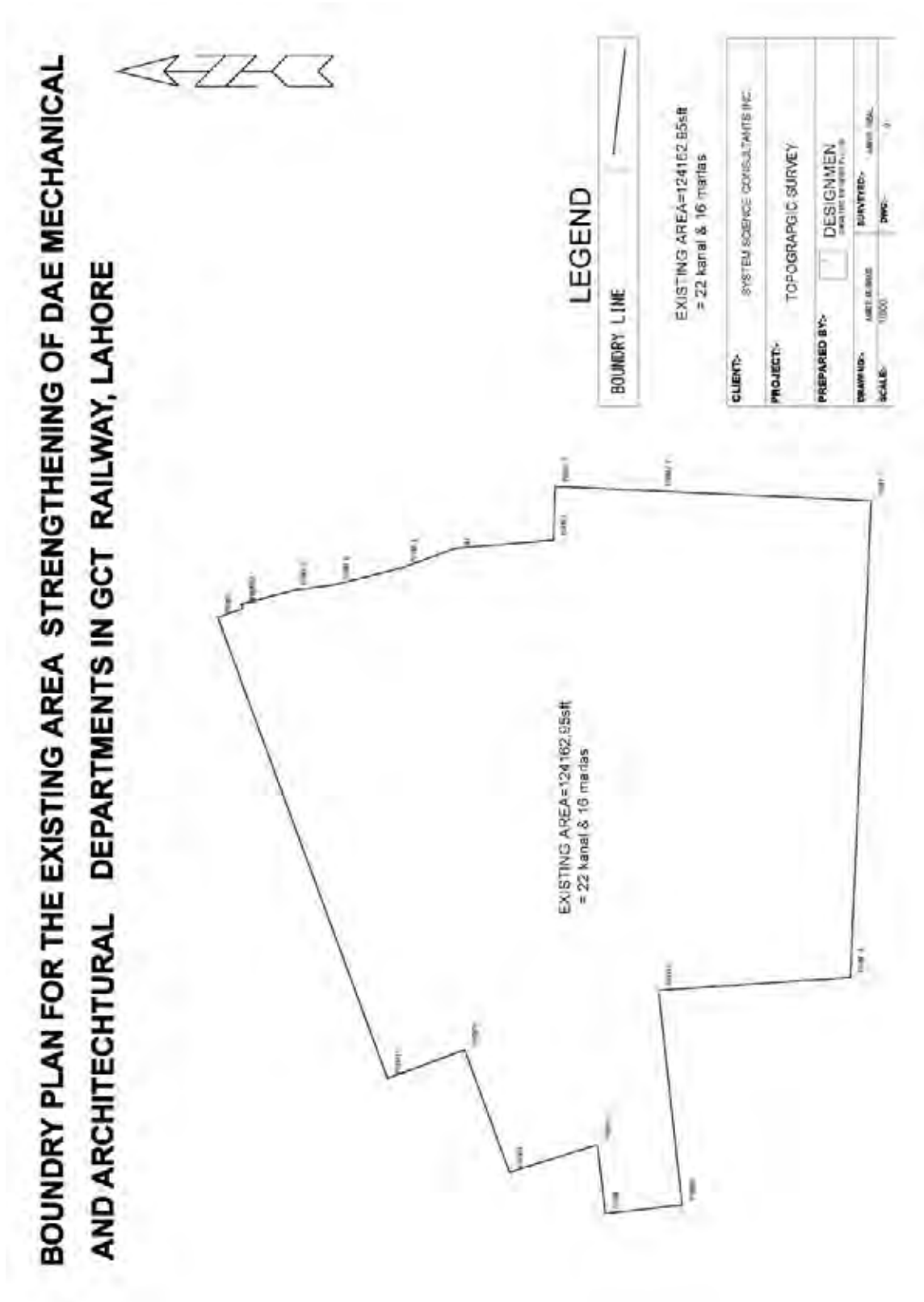

2. 地質調査結果

(1) ボーリング調査位置

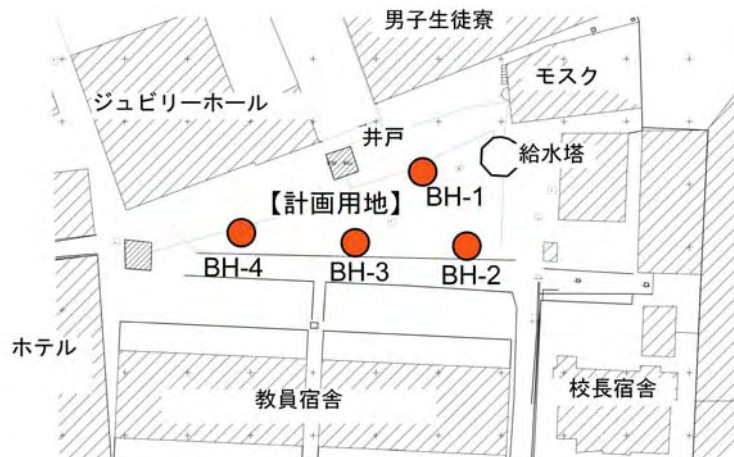

(2) 土質室内試験結果概要

SUMMARY OF TEST RESULTS (BORE HOLES)

PROJECT: GEOTECHNICAL INVESTIGATION FOR THE CONSTRUCTION OF GOVT TECHNICAL COLLEGE LAHORE
LOCATION: RAILWAY ROAD (LHR)

S. No.	B.H.#	Depth (m)	Grain Size Analysis (%) Passing			Atterberg's Limits			NMC	UC Kg/cm ²	Angle of Internal Friction (Φ) (Degree)	Bulk's Density (G/cm ³)		Specific Gravity
			Gravel	Sand	Silty Clay	LL	PL	PI				Wet	Dry	
			(%)	(%)	(%)	(%)	(%)	(%)						
1	1	5	1.5	62.5	36	NON PLASTIC			13.0		34.94	1.704	1.508	2.594
2	1	7												2.611
3	1	10	0	92	8	NON PLASTIC			17.7			2.243	1.905	
4	1	13	0.3	86.3	13.4	NON PLASTIC								
5	2	5							18.7		32.60	1.626	1.37	2.602
6	2	9												2.588
7	2	11	1	86	13	NON PLASTIC			20.5			2.349	1.949	
8	2	14	0.6	84.4	15	NON PLASTIC			19.8					
9	3	4	15	15	70	26.7	19.5	7.2	15.3	0.75		2.391	2.073	
10	3	7							20.1		33.90	1.710	1.424	2.597
11	3	11	0.4	88.6	11	NON PLASTIC			20.4			2.380	1.958	
12	3	14	0.3	88	11.7	NON PLASTIC			20.7					
13	4	5												2.606
14	4	6	7	79	14	NON PLASTIC			22.6			2.476	2.019	
15	4	8												2.571
16	4	10	0.2	87.8	12	NON PLASTIC			20.2			2.333	1.940	
17	4	15	0.7	84.3	15	NON PLASTIC			21.5					

(ボーリング調査結果： BH-1、1/2)



DESIGNMEN CONSULTING ENGINEERS (Pvt) Ltd.

BORE HOLE LOG

Bore Hole No. 1		Sheet No. 1 of 2																
Project Geotechnical Investigation For GCT		Type of Drilling: Rotary																
Location: Railway Road Lahore		Date Started: 7/10/2010																
Depth of Hole 20m		Inspector: Tahir Shahzad																
Date Completed: 8/10/2010		Ground water Table 16.5m																
Logged by: Shoib Geologist																		
Depth (M)	Description	Symbol	Sample No	S.P.T/C.P.T	SPT Curve (N Value)					M.M.C	Adeberg Limits							
					10	20	30	40	50		LL	P.L	P.I	Gravel	Sand	Silt/Clay	Sp.Gravity	
0.0-2.2	Filling Material (0.0-2.2m) Brownish grey, very soft to soft Silty Sandy Clay with pieces of bricks and gravels.	[Symbol]																
1.0			SPT-1	7														
2.0			SPT-2	5														
2.2-4.5	Silty Clay:(2.2-4.5m) Yellowish brown, firm to stiff, low to medium plastic.	[Symbol]																
3.0			UDS-1															
4.0			SPT-3	11														
4.5-6.0	Silty Sand: (4.5-6.0m) Greyish brown, medium dense to dense, fine grained	[Symbol]								13	NP	NP	NP	1-3	62.5	38	2.598	
5.0			UDS-2	18														
6.0			SPT-4	12														
6.0-9.0	Fine Sand: (6.0-9.0 m) Grey, medium dense, fine grained, slightly micaceous	[Symbol]															2.611	
7.0			SPT-5	15														
8.0			SPT-6	16														
9.0			SPT-7	18														
9.0-20.0	Coarse Sand: (9.0-20.0m) Grey, medium dense, coarse grained, slightly	[Symbol]								17.7	NP	NP	NP	0	80	8		
10.0			UDS-3															

(ボーリング調査結果： BH-1、2/2)



DESIGNMEN CONSULTING ENGINEERS (Pvt) Ltd.

BORE HOLE LOG

Bore Hole No. 1															Sheet No. 2 of 2						
Project Geotechnical Investigation For GCT					Type of Drilling: Rotary																
Location: Railway Road Lahore																					
Depth of Hole 20m					Date Started: 7/10/2010																
Date Completed: 8/10/2010					Inspector: Tahir Shahzad																
Logged by: Shoib Geologist					Ground water Table 16.5m																
Depth (M)	Description	Symbol	Sample No.	S.P.T.C.P.T	SPT Curve (N Value)					N.M.C	Atterberg Limits										
					10	20	30	40	50		LL	PL	PI	Gravel	Sand	Silt/Clay	Sp Gravity				
-11	Coarse Sand: Grey, medium dense, coarse grained, slightly micaceous		SPT-8	20																	
-12			SPT-9	23																	
-13			SPT-10	25								NP	NP	NP	0.3	86.3	13.4				
-14			SPT-11	30																	
-15			SPT-12	28																	
-16			SPT-13	28																	
-17			SPT-14	30																	
-18			SPT-15	32																	
-19			SPT-16	33																	
-20			SPT-17	33																	



DESIGNMEN CONSULTING ENGINEERS (Pvt) Ltd.

BORE HOLE LOG

Bore Hole No. 2														Sheet No. 1 of 2			
Project Geotechnical Investigation For GCT														Type of Drilling: Rotary			
Location: Railway Road Lahore														Date Started: 8/10/2010			
Depth of Hole 20m														Inspector: Tahir Shahzad			
Date Completed: 9/10/2010														Ground water Table 17m			
Logged by: Shoib Geologist																	
Depth (M)	Description	Symbol	Sample No.	S.P.T.C.P.T	SPT Curve (N Value)					N.M.C	Atterberg Limits			Gravel	Sand	Silt/Clay	Sp.Gravity
					10	20	30	40	50		LL	PL	PI				
0.0 - 2.0	Filling Material (0.0-2m)																
1.0	Brownish grey, very soft to soft Silty Sandy Clay with pieces of bricks and gravels.		SPT-1	8													
2.0			SPT-2	8													
2.0 - 4.5	Silty Clay: (2.0-4.5m) Yellowish brown to brown, firm to stiff, low to medium plastic.																
3.0			UDS-1														
4.0			SPT-3	9													
4.5 - 10.0	Fine Sand: (4.5-10m) Grey, medium dense, fine grained, slightly micaceous.																
3.0			UDS-2						16.7								2.602
6.0			SPT-4	10													
7.0			SPT-5	13													
8.0			SPT-6	15													
9.0			SPT-7	17													2.588
10.0			SPT-8	17													



DESIGNMEN CONSULTING ENGINEERS (Pvt) Ltd.

BORE HOLE LOG

Bore Hole No. 2		Project Geotechnical Investigation For GCT		Type of Drilling: Rotary		Sheet No. 2 of 2											
Location: Railway Road Lahore		Date Started: 8/10/2010		Inspector: Tahir Shahzad		Ground water Table 17m											
Depth of Hole 20m		Date Completed: 9/10/2010		Logged by: Shoib Geologist													
Depth (M)	Description	Symbol	Sample No.	SPT/CPT	SPT Curve (N Value)					N.M.C	Atterberg Limits						
					10	20	30	40	50		LL	PL	PI	Drawn	Sand	Silt/Clay	Sp Gravity
10-20	Coarse Sand: (10-20m) Grey medium dense, coarse grained, slightly micaceous.	[Symbol]	UDS-3								20.5	NP	NP	NP	1	86	13
11																	
12			SPT-9	22													
13			SPT-10	22													
14			SPT-11	28							19.8	NP	NP	NP	0.6	84.4	15
15			SPT-12	27													
16			SPT-13	30													
17			SPT-14	32													
18			SPT-15	32													
19			SPT-16	34													
20			SPT-17	35													



DESIGNMEN CONSULTING ENGINEERS (Pvt) Ltd.

BORE HOLE LOG

Bore Hole No. 3														Sheet No. 1 of 2					
Project Geotechnical Investigation For GCT														Type of Drilling: Rotary					
Location: Railway Road Lahore														Date Started: 9/10/2010					
Depth of Hole 20m														Inspector: Tahir Shahzad					
Date Completed: 10/10/2010														Ground water Table 17m					
Logged by: Shoib Geologist																			
Depth (m)	Description	Symbol	Sample No.	S.P.T/C.P.T	SPT Curve (N Value)					N.M.C	Atterberg Limits								
					10	20	30	40	50		L.L.	P.L.	P.I.	Gravel	Sand	Silt/Clay	Sp. Gravity		
0.0-2.0	Filling Material (0.0-2m) Brownish grey, very soft to soft Silty Sandy Clay with pieces of bricks and gravels	[Symbol]	SPT-1	8															
2.0-5.0	Silty Clay: (2.0-5m) Yellowish brown to brown, firm to stiff, low to medium plastic	[Symbol]	SPT-2	8															
			SPT-3	13															
			UIDS-1							15.0	MP	MP	NP	15	15	70			
5.0-9.0	Fine Sand: (5.0-9.0 m) Grey, medium dense, fine grained, slightly micaceous	[Symbol]	SPT-4	15															
			SPT-5	12															
			UIDS-2							20.1									2.697
			SPT-6	15															
			SPT-7	18															
9.0-20.0	Coarse Sand: (9.0-20.0 m) Grey, medium dense, fine grained, slightly micaceous	[Symbol]	SPT-8	20															



DESIGNMEN CONSULTING ENGINEERS (Pvt) Ltd.

BORE HOLE LOG

Bore Hole No. 3		Project Geotechnical Investigation For GCT			Type of Drilling: Rotary		Sheet No. 2 of 2											
Location: Railway Road Lahore		Depth of Hole: 20m		Date Started: 9/10/2010		Inspector: Tahir Shahzad												
Date Completed: 10/10/2010		Logged by: Shoib Geologist		Ground water Table: 17m														
Depth (M)	Description	Symbol	Sample No.	S.P.T. C.P.T	SPT Curve (N Values)					N.M.C	Atterberg Limits							
					10	20	30	40	50		LL	PL	PI	Gravel	Sand	Silt/Clay	Sp. Gravelly	
10-20	Coarse Sand: (10-20m) Grey, medium dense, coarse grained slightly micaceous																	
11			LDS-3							20.4	NP	NP	NP	0.4	89.6	11		
12			SPT-9	23														
13			SPT-10	23														
14			SPT-11	25						20.7	NP	NP	NP	0.3	88	11.7		
15			SPT-12	26														
16			SPT-13	30														
17			SPT-14	29														
18			SPT-15	33														
19			SPT-16	30														
20			SPT-17	30														



DESIGNMEN CONSULTING ENGINEERS (Pvt) Ltd.

BORE HOLE LOG

Bore Hole No. 4															Sheet No. 2 of 2			
Project		Geotechnical Investigation For GCT					Type of Drilling:		Rotary									
Location:		Railway Road Lahore					Date Started:		10/10/2010									
Depth of Hole		20m					Inspector:		Tahir Shahzad									
Date Completed:		11/10/2010					Ground water Table		17.5m									
Logged by:		Shoib Geologist																
Depth (M)	Description	Symbol	Sample No.	S.P.T.C.P.T	SPT Curve (N Value)					N.M.C	Atterberg Limits			Gravel	Sand	Sil. / Clay	Sp. Gravity	
					10	20	30	40	55		LL	PL	PI					
	Coarse Sand: (10-20m) Grey, medium dense, coarse grained, slightly micaceous																	
11			SPT-8	20														
12			SPT-9	24														
13			SPT-10	23														
14			SPT-11	25														
15			SPT-12	27						21.5	NP	NP	NP	0.7	84.3	15		
16			SPT-13	30														
17			SPT-14	32														
18			SPT-15	35														
19			SPT-16	37														
20			SPT-17	40														



DESIGNMEN CONSULTING ENGINEERS (Pvt) Ltd.

BORE HOLE LOG

Bore Hole No. 4		Sheet No. 1 of 2																
Project Geotechnical Investigation For GCT		Type of Drilling: Rotary																
Location: Railway Road Lahore		Date Started: 10/10/2010																
Depth of Hole 20m		Inspector: Tahir Shahzad																
Date Completed: 11/10/2010		Ground water Table 17.5m																
Logged by: Shoib Geologist																		
Depth (M)	Description	Symbol	Sample No.	S.P.T/C.P.T	SPT Curve (N Value)				N.M.C	Atterberg Limits				Gravel	Sand	Silt/Clay	Sp/Gravity	
					10	20	30	40		50	L.L	P.L	P.I					
0.0-2.5	Filling Material (0.0-2.5m) Brownish grey, very soft to soft Silty Sandy Clay with pieces of bricks and gravels	[Symbol]	SPT-1	7														
2.0			SPT-2	20														
2.5-4.0	Silty Clay: (2.5-4m) Yellowish brown to brown, firm to stiff, low to medium plastic.	[Symbol]	UDS-1															
4.0-10.0	Fine Sand: (4.0-10.0 m) Grey, medium dense, fine grained, slightly micaceous	[Symbol]	SPT-3	13														
5.0			SPT-4	15														2.000
6.0			UDS-2						22.6	NP	NP	NP	7	79	14			
7.0			SPT-5	16														
8.0			SPT-6	16														2.971
9.0			SPT-7	18														
10.0			UDS-3						20.2	NP	NP	NP	0.2	87.8	12			

3. カリキュラム改訂の概要（以前/現状 2010 年）

(1) 建築学科

[改定前] GCTレイルウェイ校 建築学科 指導科目体系図

	1年次	2年次	3年次
一般教養	イスラム文化及びパキスタン国史 英 語 応用数学 I 応用物理	イスラム文化及びパキスタン国史 応用数学 II	イスラム文化及びパキスタン国史
環 境		環境学習	
企画と設計	建築スケッチと作図 手書き作図と完成予想図法 I コンピュータの基礎	建築史 建築設計製図 I 手書き作図と完成予想図法 II オートCAD I	建築設計製図 II モデル制作と建築企画 オートCAD II
構 造		構造力学とR.C.C.設計	
建 設	ビル建築資材と施工 測 量 学	ビル建設 I	企業管理と人間関係 ビル建設 II 建築経済と管理 / 安全作業 建築見積と法令

[改定後]

	1年次	2年次	3年次
一般教養	イスラム文化及びパキスタン国史 英 語 コミュニケーション技法 応用数学 I 応用物理	イスラム文化及びパキスタン国史 応用数学 II	イスラム文化及びパキスタン国史
環 境		環境学習 I	環境学習 II
企画と設計	建築序論 建築スケッチ図法 I CAD製図と呈示手法 I	建築史 建築設計製図 I CAD設計と呈示手法 II	建築設計製図 II モデル制作と建築企画
構 造		構造力学と鉄筋コンクリート設計	
建 設	建築資材と建設 I	建築資材と建設 II 測 量 学	プロジェクト管理 建築施工 II 建築見積と法令

Note: 1 これらの科目は旧シラバスに小改正を施したもの。一部、科目名を変更したものもある。

2 これらの科目は新規に開発されたもの。

3 CADによる設計技法の実習が大幅に採り入れられている。

(2) 機械学科

[改定前] GCTレイルウェイ校 機械学科 指導科目体系図

	1年次	2年次	3年次
一般教養	イスラム文化及びパキスタン国史 実用英語 応用数学 応用物理 応用化学	イスラム文化及びパキスタン国史 ビジネス会話 応用数学 II 応用機械 経営管理と産業経済	イスラム文化及びパキスタン国史 産業管理と人間関係
汎用科目	コンピュータ応用 安全作業の実際 機械製図の基礎とCAD I	機械制御の基礎	
主要科目	加工実習 I	加工実習 II 機械製図 II 計測法 冶金学	加工実習 III 機械設計 治具設計加工 コンピュータ制御加工 材料試験と熱処理 流体工学 応用熱力学と資源保護 生産管理工学

[改定後]

	1年次	2年次	3年次
一般教養	イスラム文化及びパキスタン国史 実用英語 応用数学 応用物理 応用化学	イスラム文化及びパキスタン国史 ビジネス会話 応用数学 II 応用機械 経営管理と産業経済	イスラム文化及びパキスタン国史 産業管理と人間関係
汎用科目	コンピュータ応用 安全作業の実際 機械製図の基礎とCAD I	電気制御の基礎	
主要科目	加工実習 I	加工実習 II 機械製図 II 計測法 冶金学	加工実習 III 機械部品分析と設計 治具と金型設計 CAD/CAM CNC加工 材料試験と熱処理 流体工学 応用熱力学 生産管理工学

- Note: 1 これらの科目は旧シラバスに小修正を施したもの。
- 2 これらの科目は旧シラバス科目に大幅な変更を行い、名称とコード番号を変更したもの。
- 3 この科目は新規に開発されたもの。

4. 既存機材リスト（機械学科）

既存機材リスト(1/3)

アイテム 番号	機材名	既存 数量	原産国/メーカー名	製造年	稼動 台数	技協で 納入分
1. 基礎機械実習場						
M-1-1	普通旋盤	16	英国/Viceroy	1972	12	
	普通旋盤	4	日本/Takahashi	1967	3	
M-1-2	卓上ボール盤	1	英国/B.Elliot	1955	1	
M-1-3	電動式金鋸	1	英国/B.Elliot	1955	1	
M-1-4	工具研削盤	1	英国/B.Elliot	1956	1	
M-1-5	工具研削盤	1	英国/B.Elliot	1957	1	
2. 機械加工実習場						
M-2-3	デジタル式挟尺	2	中国/DIGIMAT	2009	2	
M-2-7	形削り盤	1	パキスタン/Peco	1985	1	
	形削り盤	1	英国/B.Elliot	1965	1	
M-2-8	普通旋盤	3	パキスタン/Peco	1985	0	
	普通旋盤	1	英国	1967	0	
M-2-9	平面研削盤	1	デンマーク/Suwend Jakobse	1967	1	
M-2-10	フライス盤	1	英国/Bridgeboard		1	
	フライス盤	3	パキスタン/PAK-MICO	1989	3	
	フライス盤	1	中国/Shanghai Machine	1971	1	
	フライス盤	1	スウェーデン/Sajo	1967	1	
M-2-12	万能工具研削盤	1	英国/Jackmill	2001	1	
	研磨機					
	ボール盤	1	パキスタン/Peco	1985	1	
	電動式金鋸	1	パキスタン/AL-HILAL	1985	1	
	縦型フライス盤	1	パキスタン/PMTF-KCH	1985	1	
	腕木式手動押圧機	1	パキスタン/AL-HILAL	1985	1	
	定盤	1	英国	1970	1	
	工具研削盤	1	英国	1955	1	
	ボール盤	1	パキスタン/Peco	1985	1	
	シリンダー研削盤	1	台湾	2001	1	
3. 計測実験室						
M-3-1	マイクロメーター	2	MAHR	2004	2	
	マイクロメーター	2	日本/Mitutoyo	2003	2	
M-3-2	デジタル式挟尺	2	日本/Mitutoyo	2003	2	
	デジタル式挟尺	2	中国/HL-China	1999	2	
M-3-3	デジタル式ダイヤルインジケータ	2	日本/Mitutoyo	2004	2	
M-3-4	デジタル式深さゲージ	1	日本/Mitutoyo	2004	1	
M-3-6	デジタル式高さゲージ	1	日本/Mitutoyo	2003	1	
M-3-8	ダイヤル式挟尺	4	日本/Mitutoyo	2003	4	
	ダイヤル式挟尺	1	中国	2001	1	
M-3-13	サイン・バー	1	Brown & Sharp	2003	1	
M-3-14	小口径ゲージ	1	日本/Mitutoyo	2004	1	
M-3-15	ダイヤル式分度器	2	中国	2001	2	
M-3-16	テレスコーピングゲージ	2	日本/Mitutoyo	2004	2	
M-3-17	バーニア付歯型ゲージ	4	中国	2007	4	
M-3-19	ねじマイクロメーター	4	Starret	2004	4	
M-3-20	機械式比較検査器	2	MAHR	2004	2	
M-3-21	電気式比較検査器	2	MAHR	2004	2	
M-3-24	台付きスコヤ	2	日本/Mitutoyo	2003	2	
M-3-25	検査用平面プリズム	2	Starret	2004	2	
M-3-26	内径用マイクロメーター	2	日本/Mitutoyo	2003	2	
M-3-27	内径用マイクロメーター	1	日本/Mitutoyo	2003	1	
M-3-31	精密ねじ回しセット	1	中国/New Wave Line	2003	1	
M-3-33	ウィンドウ型エアコン	2	中国/Split type	2003	2	
M-3-34	ラボ用テーブル	6	パキスタン/Local	2003	6	

既存機材リスト(2/3)

アイテム 番号	機材名	既存 数量	原産国/メーカー名	製造年	稼動 台数	技協で 納入分
4. 溶接実習場						
M-4-1	溶接用トランス	2	パキスタン/Decent	1988	2	
	溶接用トランス	2	パキスタン/Malik	2005	0	
M-4-2	アーク溶接用整流機	2	英国/Hobert	1955	1	
	電動式金鋸	1	英国/Klabger	1965	1	
	電動式金鋸	1	パキスタン/Peco	2001	1	
M-4-6	酸素アセチレンガス切断トーチ	1	英国/British Oxygen	1988	1	
M-4-7	酸素アセチレンガス溶接トーチ	4	スイス/Gloor	2001	4	
M-4-11	鍛造炉	5	英国/Viceroy	1968	1	
M-4-12	TIG式溶接機	2	日本/DAIHEN	2010	2	○
M-4-13	MIG式溶接機	2	日本/DAIHEN	2010	2	○
	スポット溶接機	1	日本/DAIHEN	1965	1	
	スポット溶接機	2	Zinser	1965	2	
	スポット溶接機	1	中国	1974	1	
	溶接用発電機	5	中国	1974	5	
	ボール盤	1	英国/Elliott Patter	1969	1	
	シーム溶接機	1	英国/Elliott Patter	1969	1	
5. 鋳物実習場						
M-5-9	バフ研磨盤	1	英国/Telisatti	1961	1	
	バフ研磨盤	1	英国/IDH^Tilsat	1955	1	
M-5-13	光高温計	1	米国/Pyrometer Inst.	1961	1	
	光高温計	1	独国/Pyro Werk	1961	1	
M-5-20	電動砂篩機	1	REG.PATOFF	1961	1	
6. 金属加工実習場						
M-6-1	万力台	42	英国/Record		42	
M-6-4	電動式金鋸	1	英国/Klaeger	1960	1	
M-6-9	足踏み式工具研削盤	1	英国/Solid	1960	1	
	薄板切断機	1	英国	1963	1	
	薄板ロール機	1	英国	1966	1	
	折曲機	1	KAOTANA	1968	1	
	電動ドリル	1	パキスタン/Peco	2000	1	
7. 材料試験・熱処理実験室						
M-7-1	ブリネル式硬さ試験機	1	英国/Avery		1	
M-7-2	ロックウェル式硬度試験機	1	英国/Avery		1	
M-7-3	アイゾット式衝撃試験機	1	英国/Avery		1	
M-7-4	万能材料試験機	1	英国/Avery		1	
	万能材料試験機	1	中国/Sai-nan		1	
M-7-5	試料切断機	1	米国/Buehier Ltd		1	
M-7-6	試料プレス機	1	米国/Buehier Ltd		1	
M-7-7	試料研磨機	1	独国/Jean Wirtz		1	
M-7-8	金属顕微鏡	1	独国/Reck Kassel		1	
M-7-9	足踏み式研磨機	1	GREIFE	1969	1	
M-7-10	電気焼鈍機	1	英国/AEW Ltd.		1	
8. 流体実験室						
M-8-1	流体摩擦実験装置	1	英国/Armfield		1	
M-8-2	ベルト水車	1	英国/Armfield		1	
M-8-3	反動タービン	2	英国/TQ		0	
M-8-5	電動式遠心力ポンプ	1	英国/Gilkes		1	
M-8-6	エンジン式遠心力ポンプ	1	英国/Gilkes		1	
M-8-9	オリフィス・フロー実験装置	1	英国/TQ		1	
M-8-11	流量測定実験装置	2	英国/TQ		2	
	ギルケス式水力タービン	2	英国/Gilkes	1969	2	
	油空圧実験装置	2	英国/TQ	1969	2	

既存機材リスト(3/3)

アイテム 番号	機材名	既存 数量	原産国/メーカー名	製造年	稼動 台数	技協で 納入分
9. CNC実習室						
M-9-10	コンピューター	12	日本/Compaq	2001	6	
11. 木工加工実習場						
M-11-1	木工用旋盤	2	米国/Boicecm	1961	1	
M-11-2	帯鋸盤	1	英国/Johns Burton	1960	1	
M-11-4	糸鋸盤	1	英国	1960	1	
	ボール盤	1	英国/POBCO	1962	1	
	空気圧縮機	1	DenMaru	1962	1	
	自動鉋盤	1	英国/Wilson	1960	1	
	丸のこ盤	1	英国	1960	1	
	平面平削り盤	1	英国/Wadking	1960	1	
	ほぞ穴加工盤	1	英国/Halifax	1961	1	
	穴あけ・溝加工盤	1	英国/Wadking S/N	1961	1	
	円板研磨器	1	英国/Power Matic	1960	1	
	電動グラインダー	1	英国/Hoiroyo	1955	1	
12. CAD 演習室						
M-12-1	コンピューター	50	日本/Dell	2010	50	○
M-12-4	多入力投影機	1	日本	2010	1	○
M-12-5	CAD用ソフト	50	日本/Autodesk	2010	50	○
M-12-6	無停電装置	5	パキスタン/Local	2010	5	○
M-12-7	コンピューター用机	50	パキスタン/Local	2010	50	○
M-12-8	椅子	50	パキスタン/Local	2010	50	○
13. 製図室						
M-13-1	製図用机、椅子	150	パキスタン/Local		115	
14. 電気機器実験室						
M-14-3	架線電流計	3	中国/Dong Hai	1990	3	
M-14-5	電力量計	1	パキスタン/ PEL	1985	1	
M-14-8	電磁開閉器	5	パキスタン/ PEM	2006	5	
M-15-9	誘導電動機、単相	3	スイス/Volkart		3	
M-15-10	誘導電動機、3相	2	スイス/Volkart		2	
	交流発電機	1	英国/AEIL	1980	1	
	整流器	2	Hirbr Electronic	1961	2	
	交流発電機	1	英国/AEIL	1961	1	
	直流電動発電機	1	英国/AEIL	1961	1	
	直流複巻発電電動機	2	英国/AEIL	1960	2	
	交流電動発電機	1	英国/General Motor	1962	1	
	直流電動発電機	1	英国/General Motor	1962	1	
	直流電動発電機	6	英国/AEIL	1961	6	
	交流電動発電機	1	英国/AEIL	1961	1	
15. 電子回路実験室						
M-15-8	2現象オシロスコープ	2	日本/Dynascan Corp		0	

5. 既存実習室・電気配電盤図 (機械学科)

LEGEND					
	PHASE INDICATION NEON LAMP	CL:	CONNECTED LOAD		
	DIGITAL TYPE VOLTMETER	TCL:	TOTAL CONNECTED LOAD		
	DIGITAL TYPE AMMETER	CTS:	CURRENT TRANSFORMERS		
	SELECTOR SWITCH	PT:	POTENTIAL TRANSFORMER		
	FUSE	KVA:	KILO VOLT AMPERE		
MPB:	MAIN PANEL BOARD	KW:	KILO WATT		
SMPB:	SUB MAIN PANEL BOARD	KA:	KILO AMPERE		
MCCB:	MOULDED CASE CIRCUIT BREAKER	RC:	RUPTURING CAPACITY		
M/S:	MAIN SWITCH	ECP-N:	EARTH CONNECTING POINT-NEURAL		
Adj:	ADJUSTABLE	ECP-B:	EARTH CONNECTING POINT-BODY		
ATP:	AMPERE TRIPLE POLE	KWH:	KILO WATT HOUR		
AFP:	AMPERE FOUR POLE	ATS:	AUTO TRANSFER SWITCH		
PFI:	POWER FACTOR IMPROVEMENT PLANT	AMFP:	AUTO MAIN FAILURE PANEL		
SCC:	STRANDED COPPER CONDUCTOR ECP				
ECP:	EARTH CONNECTING POINT				

SCHEDULE OF CABLES					
CABLE NO:	CABLE SIZE:	CABLE FROM:	CABLE TO:	PIPE SIZE:	REMARKS
LV1	95mm, 4CORE	LESCO TRANSFORMER, 200KVA	ENERGY (KWH) METER	OPEN AIR	A.C
LV2	95mm, 4CORE	ENERGY (KWH) METER	MCCB NO:1 IN LOW VOLTAGE PANEL	OPEN AIR	A.C
LV3	95mm, 4CORE	LESCO TRANSFORMER, 200KVA	ENERGY (KWH) METER	OPEN AIR	A.C
LV4	95mm, 4CORE	ENERGY (KWH) METER	MCCB NO:2 IN LOW VOLTAGE PANEL	OPEN AIR	A.C
LV5	95mm, 4CORE	LESCO TRANSFORMER, 200KVA	ENERGY (KWH) METER	OPEN AIR	A.C
LV6	95mm, 4CORE	ENERGY (KWH) METER	ATS PANEL THROUGH 400ATP, MCCB	OPEN AIR	A.C
LV7	95mm, 4CORE	GENERATOR 65KVA	ATS PANEL	2" DIA	A.C
LV8	95mm, 4CORE	ATS PANEL	ARCH. DEPT./P.OFFICE/CAD CAM/TRAINING ROOM	OPEN AIR	A.C
LV9	95mm, 4CORE	LV PANEL 440V, MCCB NO:2	MAIN POWER DB OF AD.MACHINE LAB	OPEN AIR	A.C
LV9'	95mm, 4CORE	JOINT WITH LV9	MAIN POWER DB OF B.MACHINE LAB	OPEN AIR	A.C
LV9''	95mm, 4CORE	JOINT WITH LV9'	MAIN POWER DB OF WELDING LAB	OPEN AIR	A.C
LV10	95mm, 4CORE	LV PANEL 440V, MCCB NO:1	MAIN POWER DB OF R.A.C DEPARTMENT	OPEN AIR	A.C
LV11	95mm, 4CORE	MAIN POWER DB OF R.A.C DEPARTMENT	MATERIAL TESTING LAB DB	2" DIA	A.C
LV12	95mm, 4CORE	MATERIAL TESTING LAB DB	POWER LAB MAIN PANEL BOARD	2" DIA	A.C
LV12'	95mm, 4CORE	JOINT WITH LV12	WOOD WORK SHOP MAIN DB	2" DIA	A.C
LV13	2.5mm	POWER LAB MAIN PANEL BOARD	METAL LAB	1" DIA	A.C

SPECS. TABLE OF LOW VOLTAGE PANEL, AD.MACHINES LAB & B.MACHINES LAB			
S.NO:	DESCRIPTION:	BRAND:	QUANTITY:
1	400ATP, MCCB RC:25KA	TERASAKI	05
2	200ATP, MCCB RC:15KA	TERASAKI	03
3	125ATP, MCCB RC:15KA	TERASAKI	03
4	32ATP, MCCB RC:15KA	TERASAKI	48
5	20ATP, MCCB RC:15KA	TERASAKI	21
6	C.T, 15VA, 400/5A	RIKZEN	12

Existing Dwg.	DESIGNED BY:	DRWN BY:	TITLE:	PROJECT	GTC RAILWAY ROAD OF PUNJAB PROVINCE LAHORE PAKISTAN.	DRG.NO.
	CHECKED BY:	BADAR HESAR	- LEGEND			
	APPROVED BY:	SAR 04-10-2010	- SCHEDULE OF CABLES			
	Y.NAKANISHI	SOLE N-T-5	- SPECS. TABLE			SLD-E-01

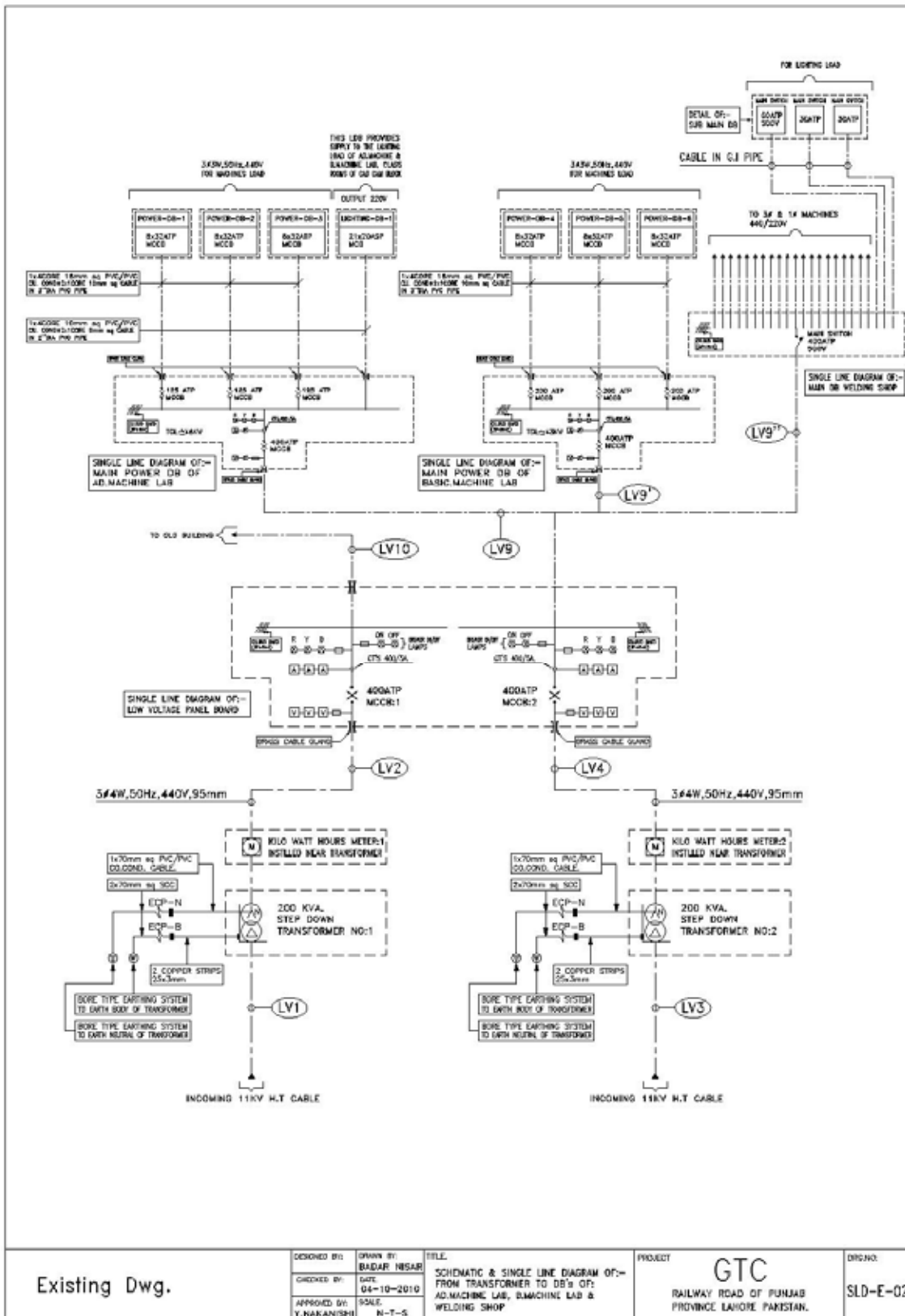

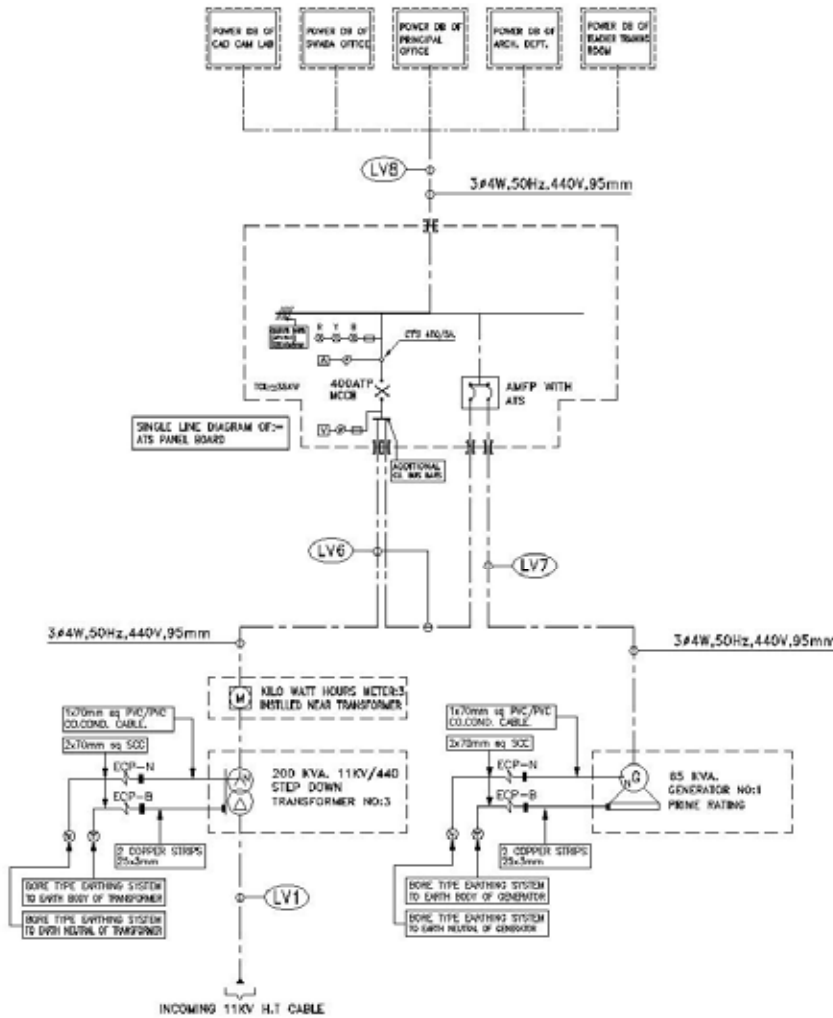

Existing Dwg.

DESIGNED BY:	DRAWN BY:
CHECKED BY:	DATE:
APPROVED BY:	SCALE:
	N-T-5

TITLE:
SINGLE LINE DIAGRAM OF:-
ATS PANEL BOARD

PROJECT
GTC
RAILWAY ROAD OF PUNJAB
PROVINCE LAHORE PAKISTAN.

DWG. NO.
SLD-E-03

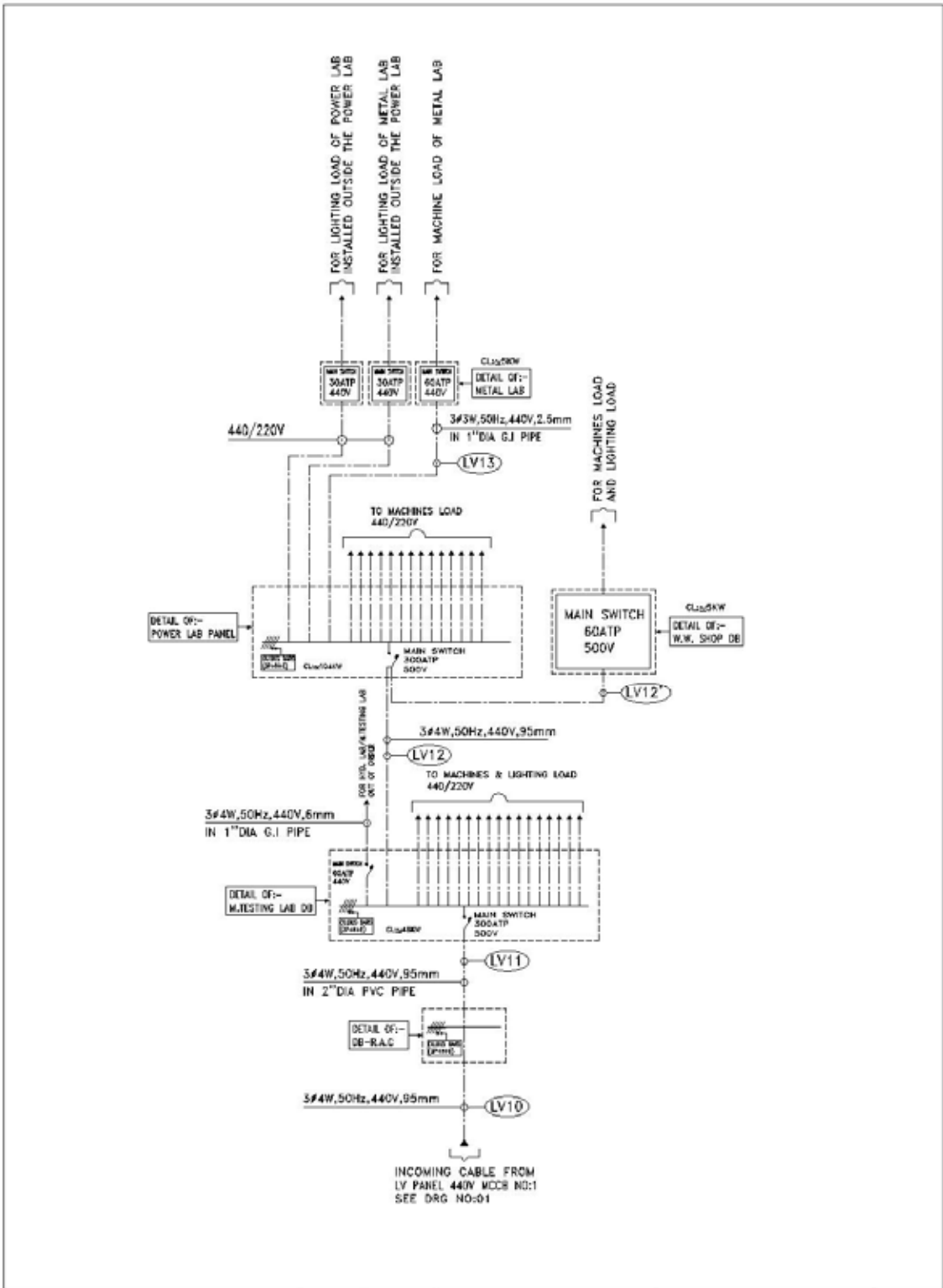

Existing Dwg.	DESIGNED BY:	DRAWN BY:	TITLE:	PROJECT	GTC RAILWAY ROAD OF PUNJAB PROVINCE LAHORE PAKISTAN.	DRG. NO.
	CHECKED BY:	DATE:	DISTRIBUTION DIAGRAM FROM			
	APPROVED BY:	SCALE:	LV PANEL 440V(MCCB NO:01) TO			
			M.T LAB, W.W.SHOP, POWER & M.LAB			
		M-T-S				SLD-E-04

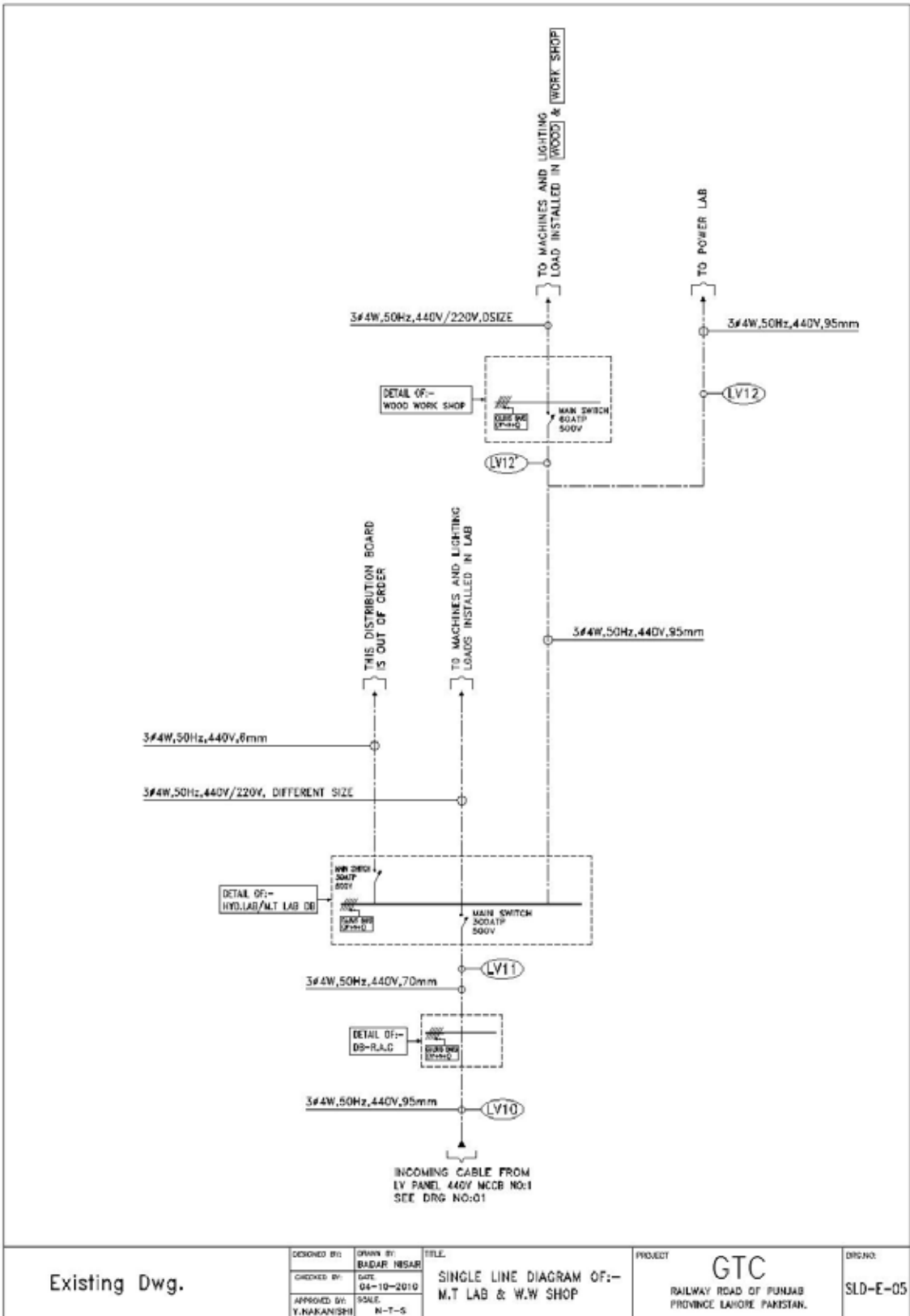

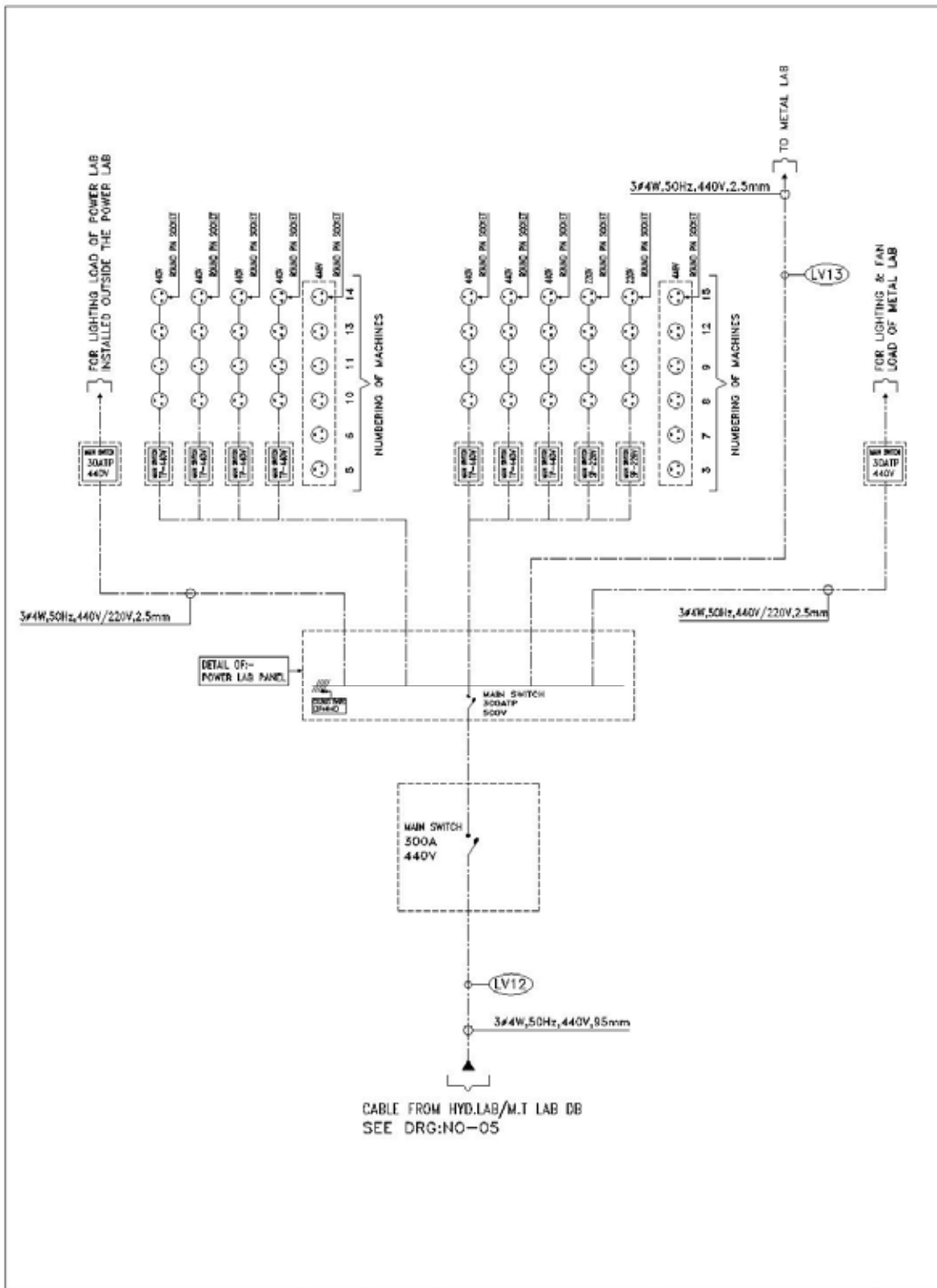

Existing Dwg.	DESIGNED BY:	DRAWN BY:	TITLE:	PROJECT:	DRG. NO.:
	CHECKED BY:	BADAR NISAR	SINGLE LINE DIAGRAM OF:-	GTC	SLD-E-06
	APPROVED BY:	DATE:	POWER LAB	RAILWAY ROAD OF PUNJAB	
	Y. NAKANISHI	04-10-2010	M-T-S	PROVINCE LAHORE PAKISTAN.	

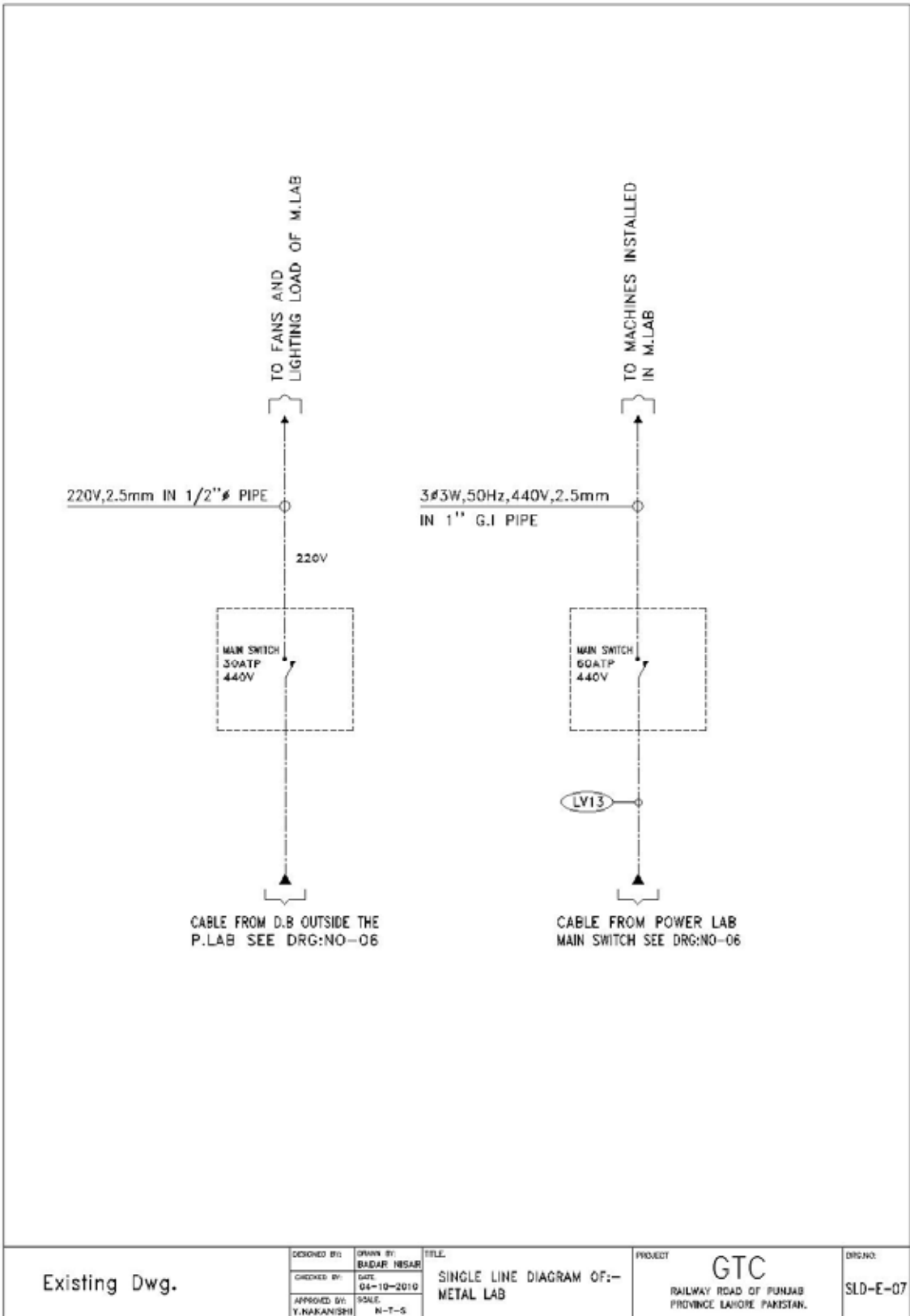

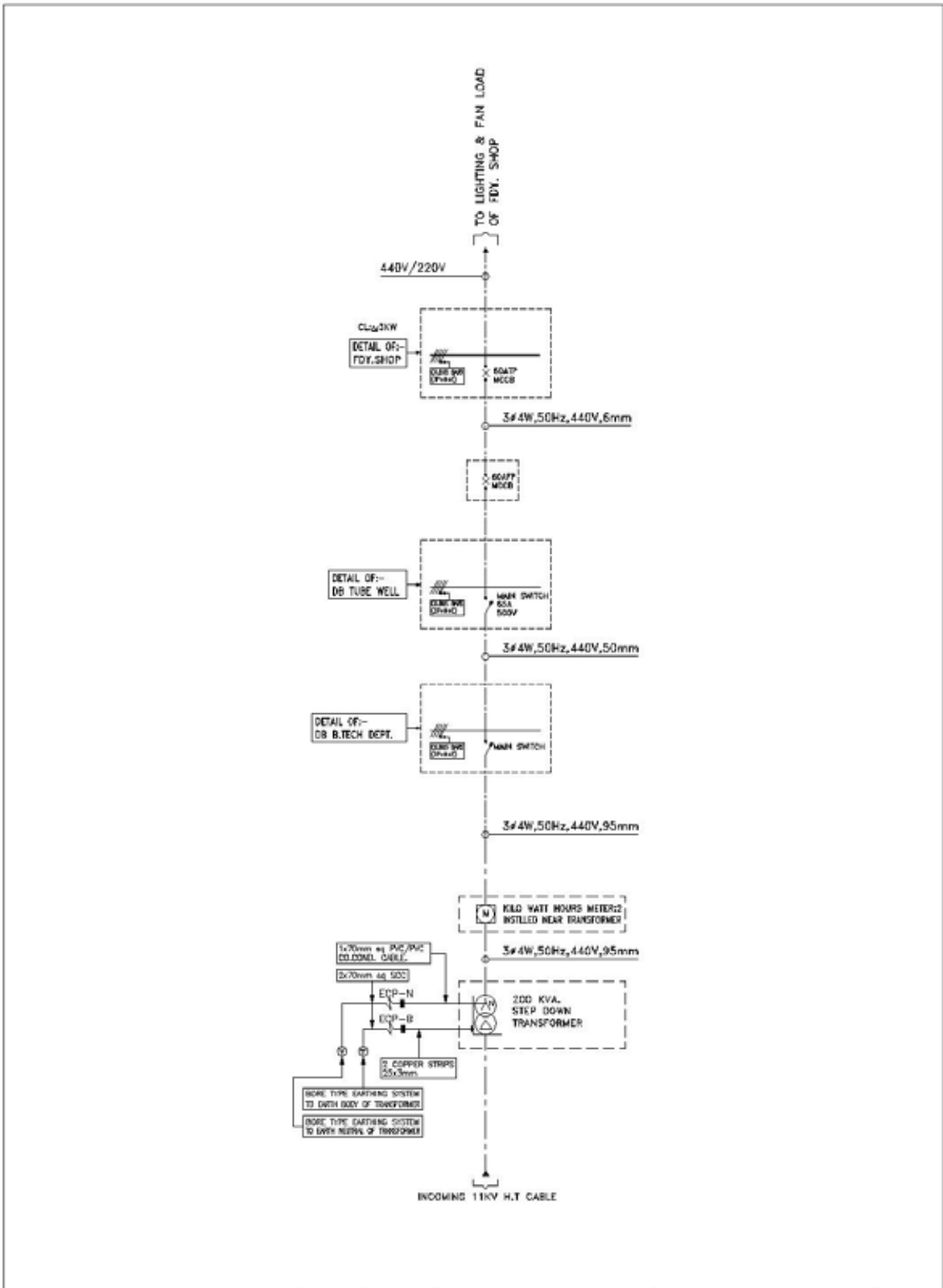

Existing Dwg.	DESIGNED BY:	QMAN BY:	TITLE:	PROJECT:	DRG. NO.:
	CHECKED BY:	BADAR NISAR	SINGLE LINE DIAGRAM OF:-	GTC	RAILWAY ROAD OF PUNJAB PROVINCE LAHORE PAKISTAN.
	DATE:	04-10-2010	FDY. SHOP	S.I.D-E-08	
	APPROVED BY:	SCALE:	N-T-5		

6. 計画機材レイアウト図

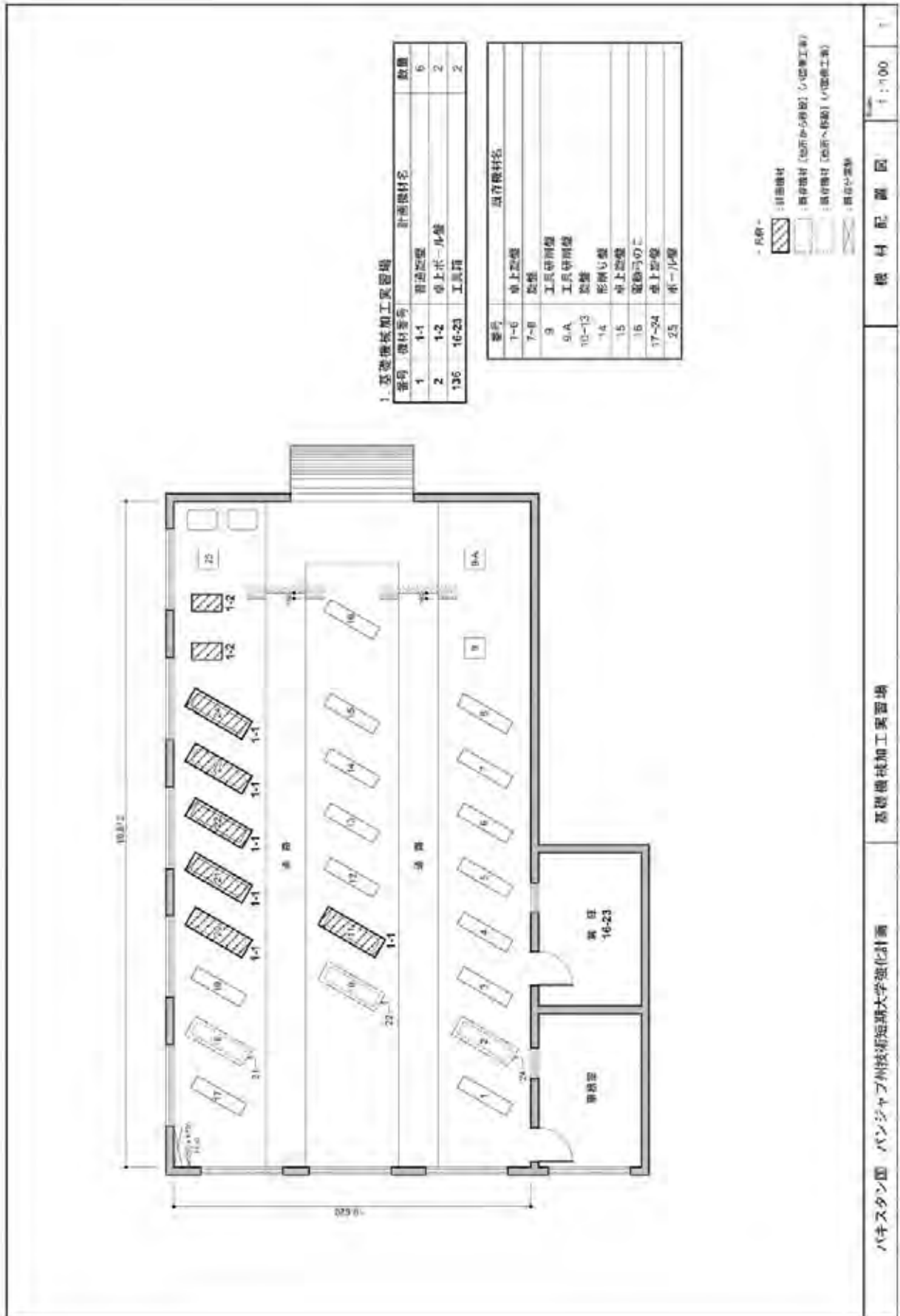

2. 応用機械加工実習場

番号	機材番号	計画機材名	数量
1	2-1	普通旋盤	5
3	2-2	ホブ研切機	1
4	2-3	縦型フライス盤	2
5	2-4	形削り機	1
6	2-5	平面研削盤	1
7	2-6	万能工具研削盤	1
8	2-7	マイクログメーター	5
9	2-8	デジタル式決尺	5
136	16-23	工具箱	2

番号	既存機材名	数量
1-3	フライス盤	5HP
4	ボール盤	2HP
5-8	フライス盤	5HP
9	電動式金剛	2HP
10	縦型フライス盤	3HP
11-13	普通旋盤	2HP
14	普通旋盤	3HP
15	平面研削盤	3HP
16	萬能式手動研削盤	...
17	形削り機	3HP
18	定盤	...
19	形削り機	3HP
20	工具研削盤	2HP
21	ボール盤	2HP
22	工具の測定研削盤	2HP
23	シリンダー研削盤	7HP

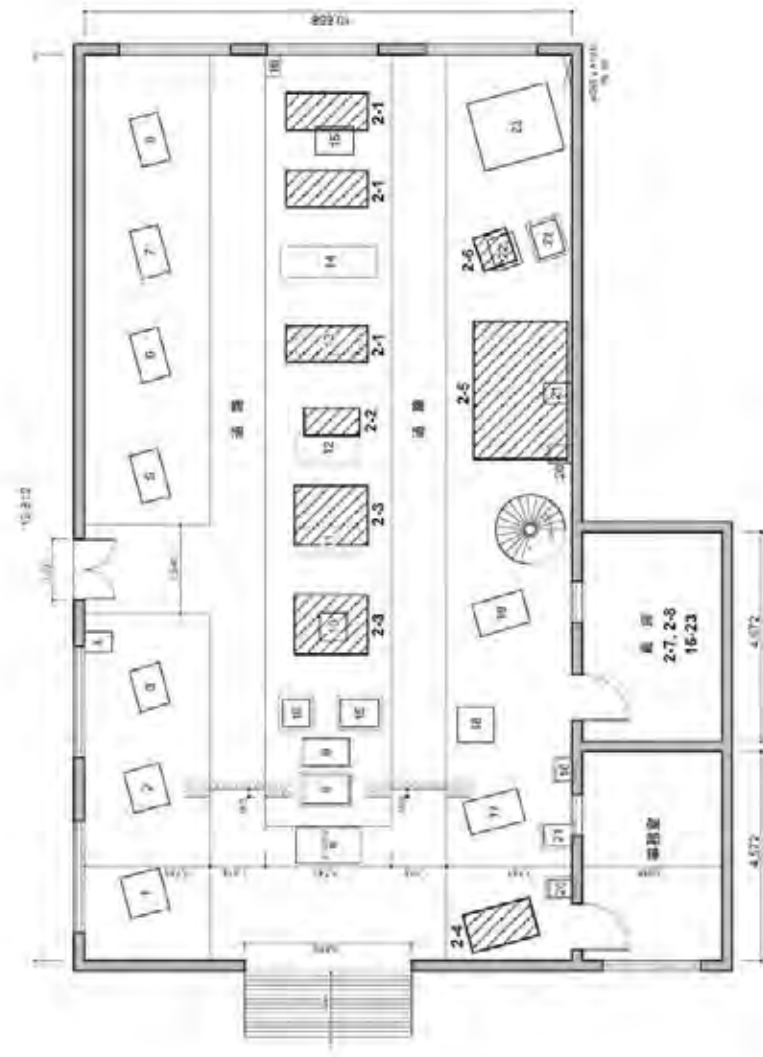

3. 計測実験室

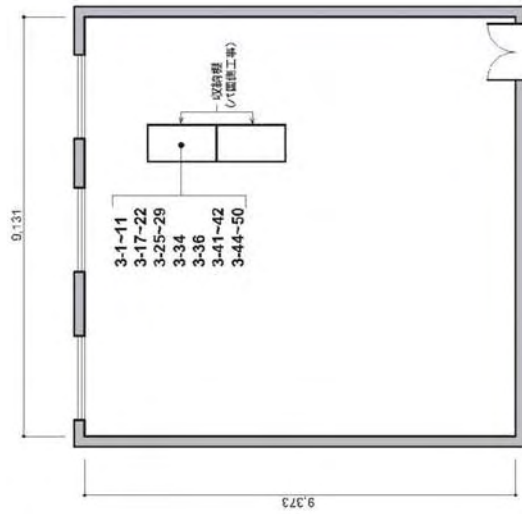

番号	機材番号	計画機材名	数量
8	3-1	マイクロメーター	10
10	3-2	アンピル付マイクロメーター	5
9	3-3	デジタル式決尺	10
11	3-4	デジタル・ピッチ決尺	5
12	3-5	ダイヤル・ゲージ	10
13	3-6	デジタル式深さゲージ	10
14	3-7	デジタル式高さゲージ	5
15	3-9	ダイヤル式決尺	5
16	3-10	ダイヤル式内径計測器	3
17	3-11	ダイヤル式決尺	3
18	3-17	内径用マイクロメーター	3
19	3-18	溝幅決尺	3
20	3-19	機械式比較検査器	2
21	3-20	電気式比較検査器	2
22	3-21	工具顕微鏡	2
23	3-22	深さ測表器	10
24	3-25	鋼製定盤	4
25	3-26	狭みゲージセット	10
26	3-27	輪ゲージセット	2
27	3-28	ねじ輪ゲージ	5
28	3-29	分度器	10
29	3-34	ポイント・マイクロメーター	5
30	3-36	深さ測定用マイクロメータ	4
31	3-41	半径ゲージ	5
32	3-42	ねじ溝深さゲージ	10
33	3-44	万能歯車検査装置	1
34	3-45	デジタル・ゲージ検査器	1
35	3-46	勾配ゲージ	3
36	3-47	平行試料片	10
37	3-48	表面粗さ標準試片	2
38	3-49	きりゲージ	2
39	3-50	直角Vブロック	5

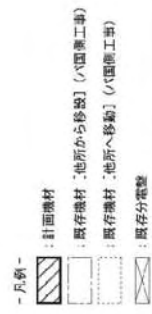

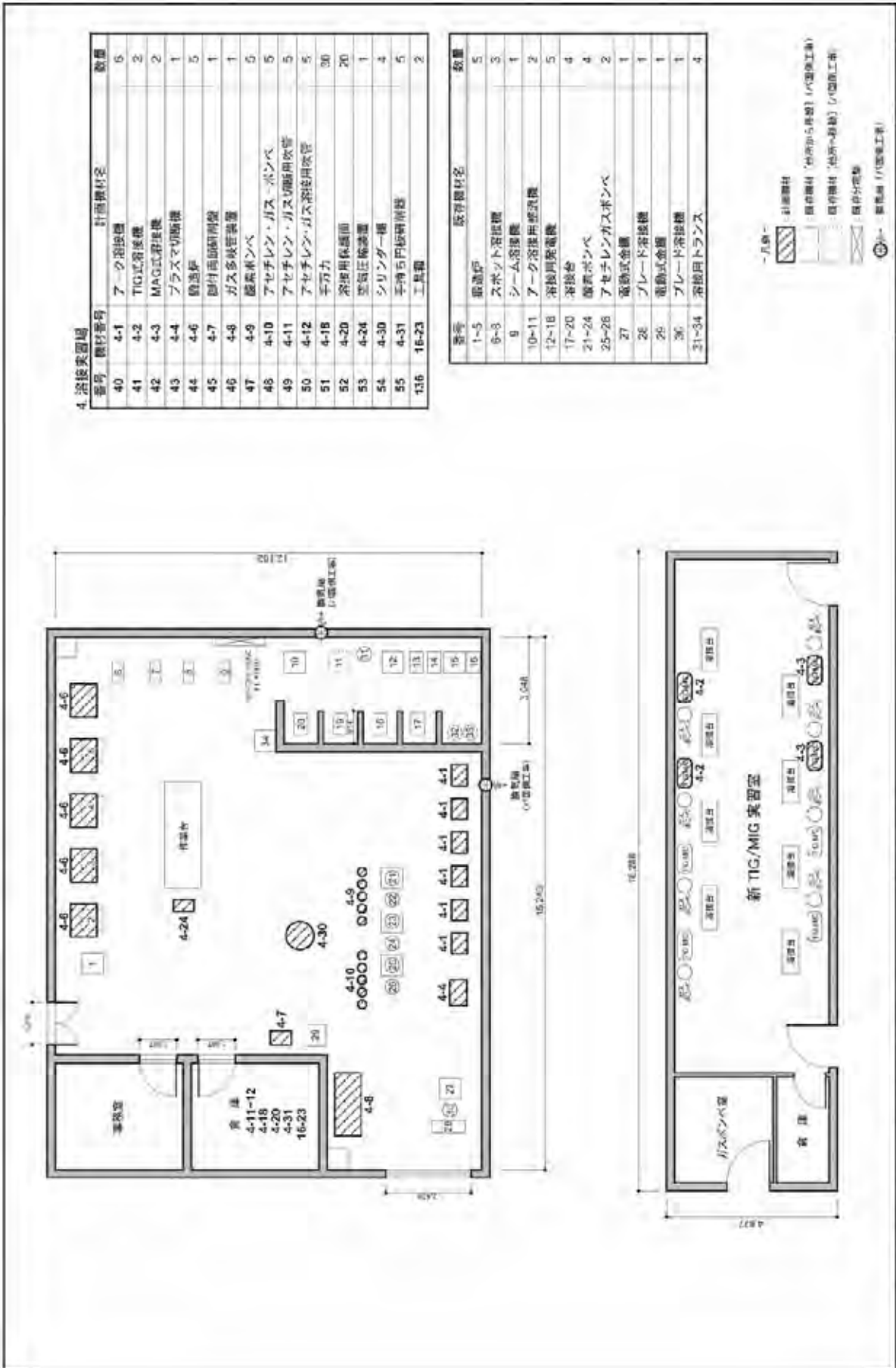

4. 溶接実習場

番号	機材番号	計画機材名	数量
40	4-1	アーク溶接機	5
41	4-2	TIG式溶接機	2
42	4-3	MAG式溶接機	2
43	4-4	プラズマ切断機	1
44	4-6	動力床	5
45	4-7	部材吊り装置	1
46	4-8	ガス多岐管装置	1
47	4-9	酸素ボンベ	5
48	4-10	アセチレン・ガス・ボンベ	5
49	4-11	アセチレン・ガス切断用吹管	5
50	4-12	アセチレン・ガス溶接用吹管	5
51	4-18	千力力	30
52	4-20	溶接用保護面	20
53	4-24	空気圧検測器	1
54	4-30	シリンダー横	4
55	4-31	手押し円板研削盤	5
136	16-23	工具量	2

番号	設備機材名	数量
1-5	排煙炉	5
6-3	スポット溶接機	3
9	シーム溶接機	1
10-11	アーク溶接用感流機	2
12-18	溶接用電源機	5
17-20	溶接台	4
21-24	酸素ボンベ	4
25-28	アセチレンガスボンベ	2
27	電動式金庫	1
26	ブレード溶接機	1
26	電動式金庫	1
30	ブレード溶接機	1
21-34	溶接用トランス	4

- 凡例
- 計画機材
 - 既存機材 (材料中5再機) (バ工場工場)
 - 既存機材 (材料中5再機) (バ工場工場)
 - 機材分電盤
 - 新機材 (バ工場工場)

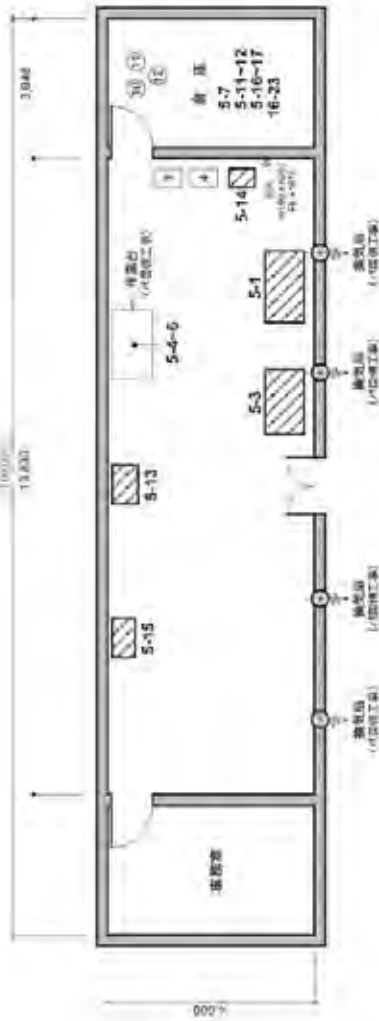

5. 調物実置場

番号	機材番号	計画機材名	数量
56	5-1	振注用揚子	1
57	5-3	振動圧押造型機	1
58	5-4	砂臼機	1
59	5-5	透過率計	1
60	5-6	圧縮機	1
61	5-7	光高温計	2
62	5-11	印刷機	6
63	5-12	型心	6
64	5-13	電動砂降機	1
45	5-14	型付両面研削機	1
53	5-15	空気圧降装置	1
65	5-16	送風機	2
66	5-17	空気機耐機	5
136	16-23	工具	2

番号	既存機材名	数量
3-4	パフ降機	2
10-11	光高温計	2
12	電動砂降機	1



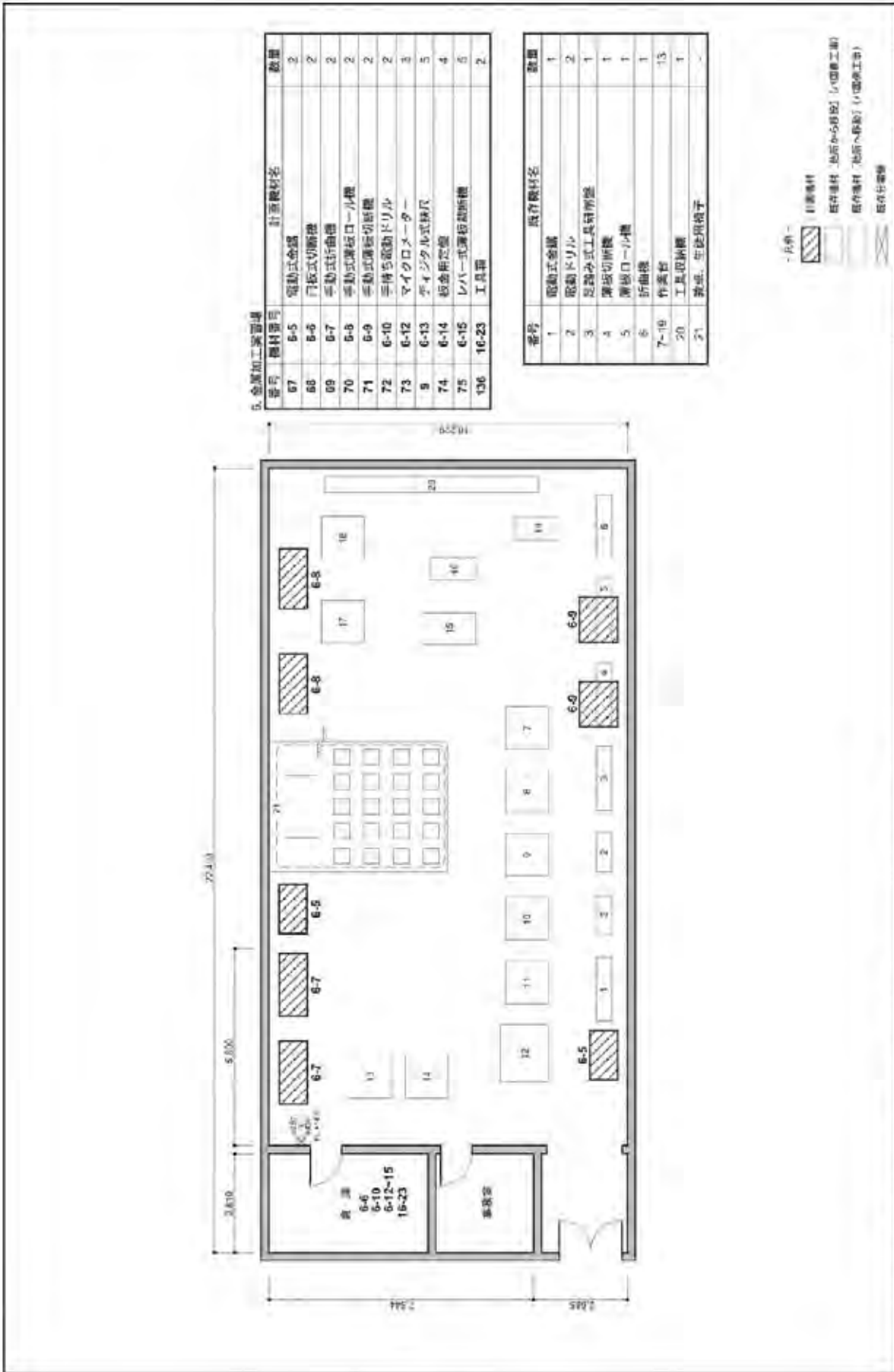

5. 金属加工実習場

番号	機材番号	計画機材名	数量
67	6-5	電動式金鋸	2
68	6-6	円板式切断機	2
69	6-7	手動式折曲機	2
70	6-8	手動式薄板ローラー	2
71	6-9	手動式薄板切断機	2
72	6-10	手持ち電動ドリル	2
73	6-12	マイクロナーター	3
9	6-13	デジタル式線尺	5
74	6-14	板金研削盤	4
75	6-15	レバー式薄板切断機	5
136	16-23	工具棚	2

番号	機材番号	計画機材名	数量
1		電動式金鋸	1
2		電動ドリル	2
3		足踏み式工具研削盤	1
4		薄板切断機	1
5		薄板ローラー	1
6		折曲機	1
7-16		作業台	13
20		工具収納棚	1
21		作業台、作業用椅子	-

- ・凡例
- 作業機材
 - 既設機材、他所へ5倍戻し(400番工庫)
 - 既設機材、他所へ移動(400番工庫)
 - 既設作業機

7. MATERIAL TESTING AND HEAT TREATMENT LAB.

7. 材料試験・熱処理実験室

番号	機材番号	計画機材名	数量
76	7-1	ブリネル式硬さ試験機	1
77	7-2	ロックウェル式硬さ試験機	1
78	7-8	金属顕微鏡	1
79	7-9	ねじり試験機	1
80	7-10	引張疲労試験機	1
81	7-11	電気溶接機	1
82	7-12	酸化・還元炉	1
45	7-13	脚付向洋研削盤	1
83	7-14	超音波試験機	1
136	16-23	工具箱	2



10. 熱力学実験室

番号	機材番号	計画機材名	数量
113	10-3	点火時期実験装置	1
114	10-9	空気圧管理実験装置	1
115	10-10	ガス・タービン実験装置	1
116	10-12	燃気ボイラー実験装置	1
136	16-23	工具箱	2

既存材料実験室からの移設 (バキューム)

番号	機材番号	計画機材名	数量
1		ブリネル硬度計	1
2		焼戻し炉	1
3		試料収納機	1
4		アイソット熱学試験機	1
5		万能試験機	1
6		試料圧搾装置	1
7		試料研削装置	1
8		卓上研削機	1
9		ロックウェル硬度計	1
10		万能試験機	1



8. 流体実験室

番号	機材番号	計画機材名	数量
84	8-1	流体摩擦実験装置	2
85	8-2	流量測定実験装置	1
86	8-3	ベルヌーイ定理の実験装置	1
87	8-4	オリフィス・フロー実験装置	1
88	8-5	流体エネルギー損失実験装置	1
89	8-6	過心ポンプ実験装置	1
90	8-7	軸流ポンプ実験装置	1
91	8-8	ピストン・ポンプ実験装置	1
92	8-9	ベルトン・タービン	1
93	8-10	軸流タービン	1
94	8-11	フランシス・タービン	1
95	8-12	輻流タービン	1
96	8-13	油空圧部品セット	2
97	8-14	油空圧実験装置	1
98	8-15	軸流ポンプ・カット・モデル	1
99	8-16	ボール形状弁カット・モデル	1
100	8-17	ベン・ポンプ・カット・モデル	1
101	8-18	ピストン・ポンプ・カット・モデル	1
102	8-19	デジタル式測圧機	1
136	16-23	工具箱	2

番号	既存機材名	数量
1	流体摩擦実験装置	1
2	ベルトン水車 / 衝動タービン	1
3	反動タービン (軸流)	1
4	反動タービン (半径流)	1
5-6	ギルケス式水カタービン	2
7	電動式過心カタービン	1
8	エンジン式過心カタービン	1
9-10	油空圧実験装置	2
11	電動モーター付レシンプンポンプ	1

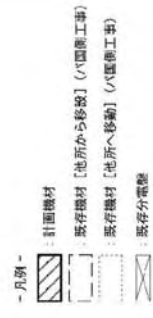
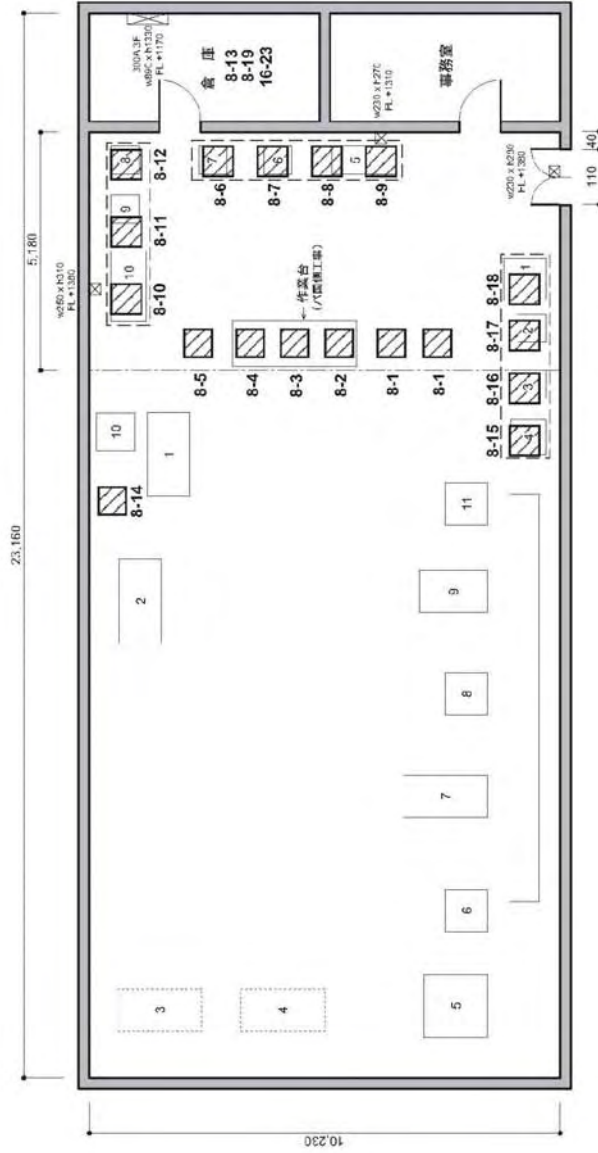

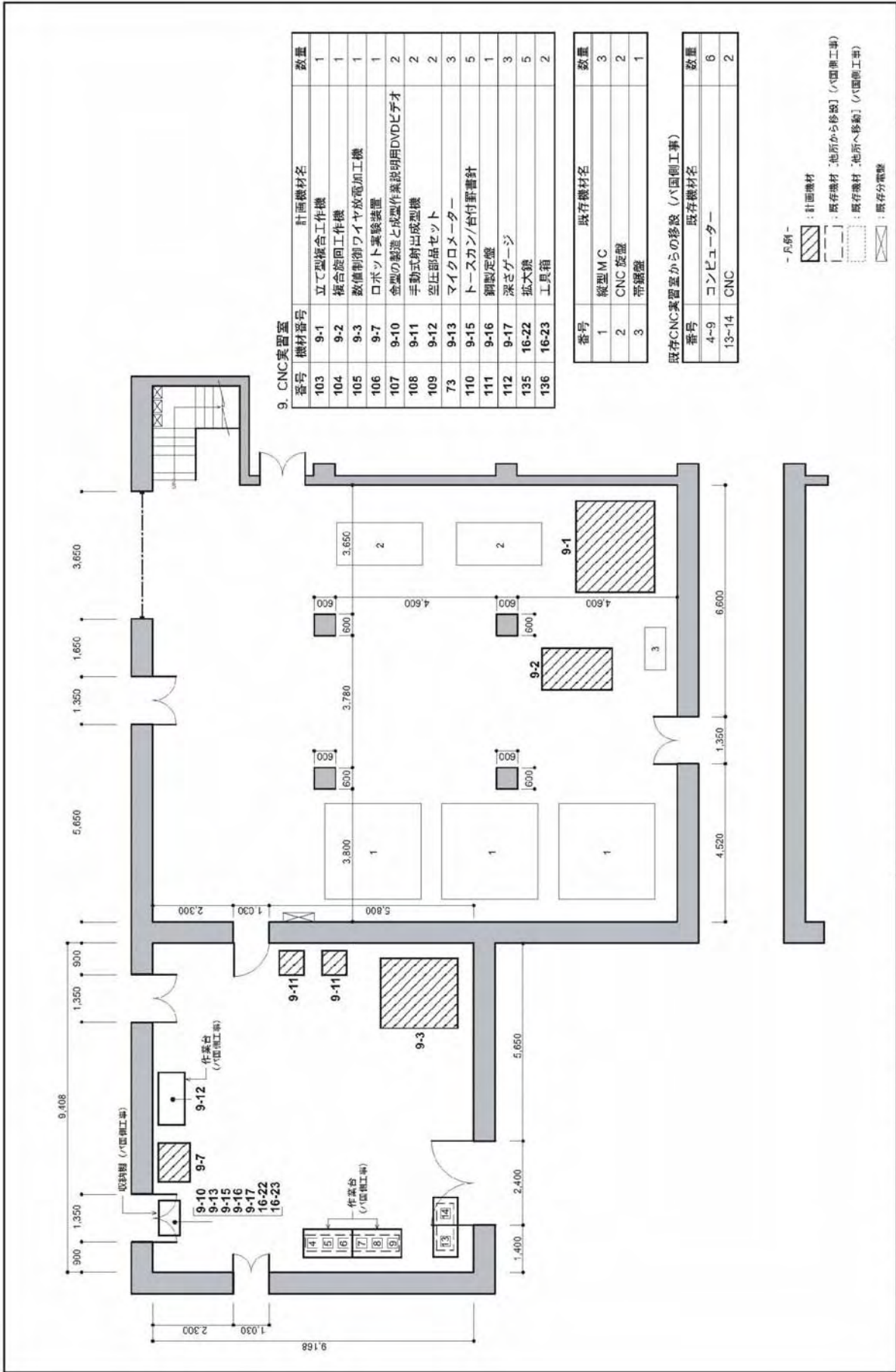

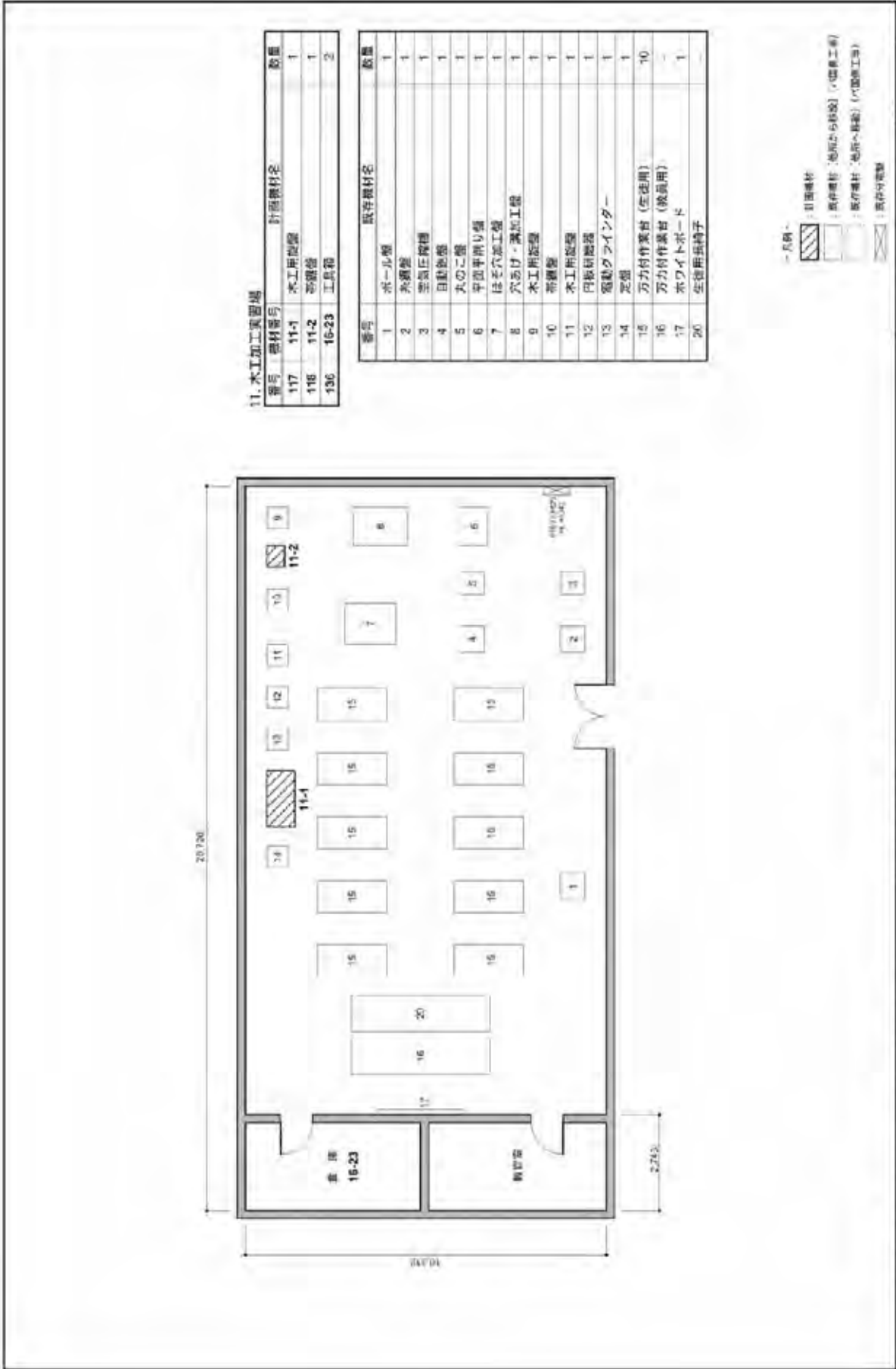

11. 木工加工実習場

番号	器材番号	計画機材名	数量
117	11-1	木工用旋盤	1
118	11-2	砂研盤	1
136	16-23	工具箱	2

番号	既存機材名	数量
1	ボール盤	1
2	糸鋸盤	1
3	電動圧搾機	1
4	自動巻盤	1
5	木のこ盤	1
6	平頭平削り盤	1
7	はぎ穴加工盤	1
8	穴あけ・溝加工盤	1
9	木工用旋盤	1
10	帯鋸盤	1
11	木工用旋盤	1
12	円盤研盤	1
13	電動グラインダー	1
14	定盤	1
15	万力付作業台 (生徒用)	10
16	万力付作業台 (教員用)	-
17	ホワイトボード	1
20	生徒用工具箱	-

凡例

- : 計画機材
- : 既存機材 (他所から移設) (※器具等)
- : 既存機材 (他所へ移設) (※園芸工場)
- : 既存機材

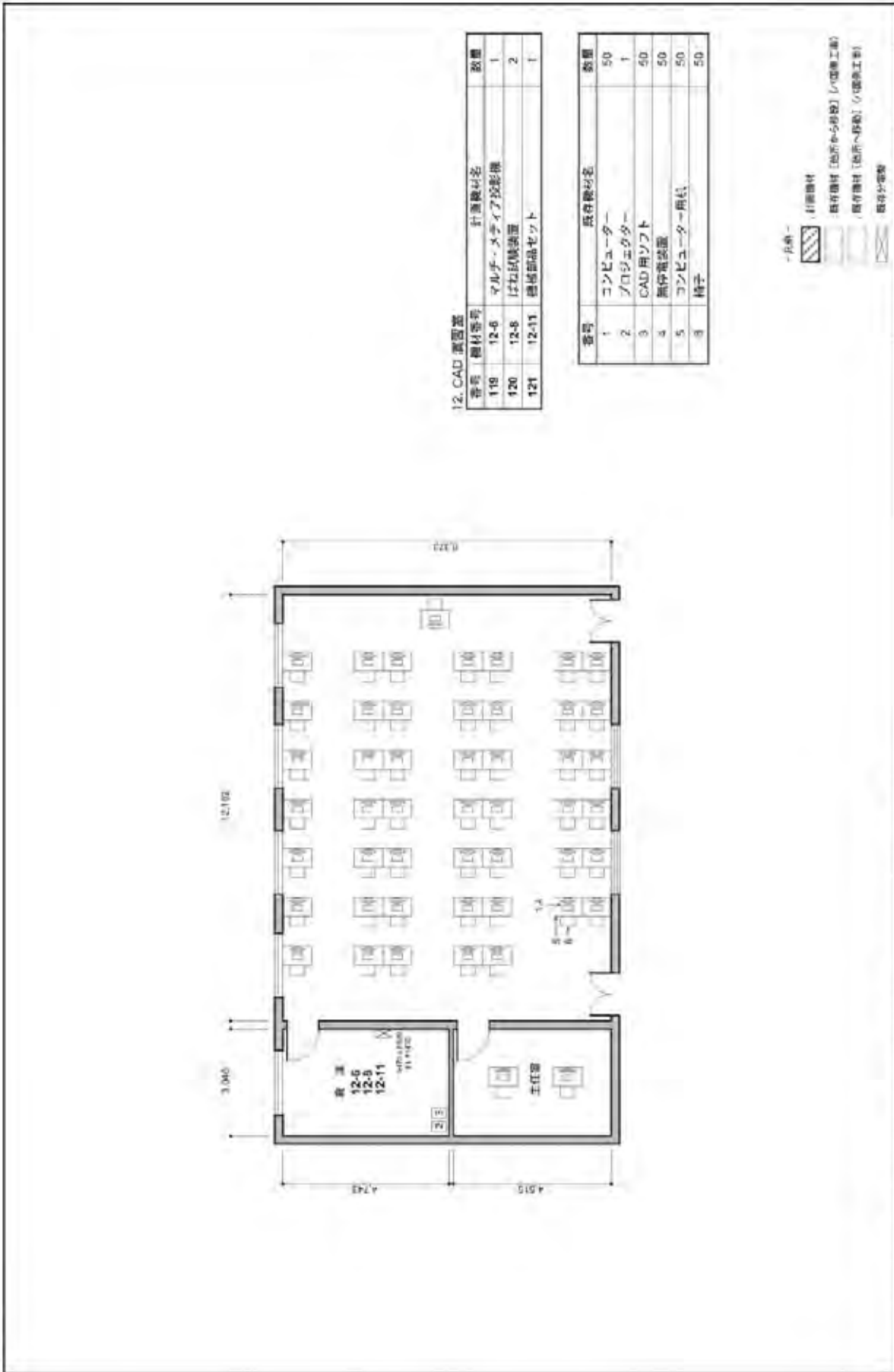

12. CAD 演習室

番号	機材番号	計画機材名	数量
119	12-6	マルチメディア投影機	1
120	12-8	ばね試験装置	2
121	12-11	機材部品セット	1

番号	既存機材名	数量
1	コンピューター	50
2	プロジェクター	1
3	CAD用ソフト	50
4	無停電装置	50
5	コンピューター用机	50
6	椅子	50

- 印刷機-
- 印刷機材
- 機材番号「12-6-5-5」(プロジェクター)
- 機材番号「12-8-5-5」(ばね試験装置)
- 機材番号「12-11-5-5」(機材部品セット)

14. 電気機器実験室

番号	機材番号	計画機材名	数量
122	14-1	電気機器実験装置	2
123	14-2	変圧器実験装置	2
124	14-3	回路遮断機実験装置	2
125	14-4	直流及び交流電圧計	10
126	14-9	回路計	10
127	14-10	線径ゲージ	20
128	14-15	位相計	5

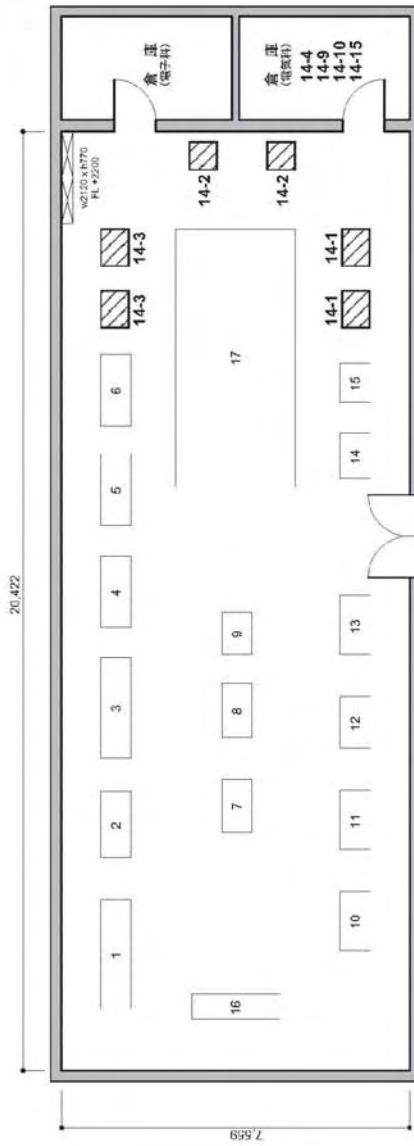

番号	既存機材名	数量
1	交流発電機	4HP
2	整流器	20A
3	交流発電機	5KVA
4	直流電動発電機	3KVA
5-6	直流巻架電動機	3HP
7	交流電動発電機	5HP
8	直流電動発電機	25KW
9	直流電動発電機	8KW
10	直流電動発電機	5HP
11	直流電動発電機	3HP
12	直流電動発電機	8HP
13	直流電動発電機	4HP
14	ブレーキ用プーリー試験機	8HP
15	ブレーキ用プーリー試験機	5HP
16	教卓	1
17	生徒用机、椅子	-

- 凡例 -
- : 計画機材
 - : 既存機材 [他所から移設] (国内工事)
 - : 既存機材 [他所へ移転] (国内工事)
 - : 既存分電盤



15. 電子回路実験室

番号	機材番号	計画機材名	数量
129	15-2	工業電子実験装置	5
130	15-3	PLC実験装置	5
126	15-4	回路計	10
131	15-5	半導体特性試験装置	5
132	15-6	定電圧電源	5
133	15-7	パソコン用電源	2
134	15-8	多目的実験装置	2

番号	既存機材名	数量
1-12	コンピューター	12
13-14	PCMC	2



