

Third (3rd) Evaluation Summary of Self-Evaluation for Hydro & Diesel Power Station, Mondul Kiri Electricity, EDC

Date: 2011/2/17	Name	Y. Soyen Section chief, OR	Eng Rithy Group Leader		Um Monichetra Operator		C. Kosal Operator		Average	Corresp. A to E	Evaluated by JICA
			1st	3rd	1st	3rd	1st	3rd			
Tasks (O'Moleng)	Position in charge										
Check 1 : Plan											
Planning avility for Hydro/DG P.S (Task Code : TM2, TR2 & TD2)	①M & L term plan	60	100	60	100	60	100	60	100	A	A
	②Periodic inspection plan	60	100	80	100	80	100	75	100	A	A
	③Peplacement & repire plan	60	100	60	100	60	100	60	100	A	A
Check 2 : Operation											
Operation avility for Hydro/DG P.S (Code TM3, Tr3 & TD3)	①Start/paralle-in/load/stop	100	100	80	100	100	100	95	100	A	A
	②Emergence or quick stop	100	100	60	100	100	100	90	100	A	A
	③Balance operation of water level	100	100	40	100	100	100	85	100	A	A
Check 3 : Maintenance											
Maintenance avility for Hydro P.S (Task Code : TM3, TR3 & TD4)	①Daily, weekly, monthly inspections	100	100	100	100	100	100	100	100	A	A
	②Periodic detailed inspection	100	100	100	100	100	100	100	100	A	A
	③Management of tools & equipment	100	100	100	100	100	100	100	100	A	A
	④Management of spare parts	100	100	100	100	100	100	100	100	A	A
Check 4 : Trouble Shooting											
Counter measuring availability for Hydro/DG P.S	①Recovery of light faults	100	100	100	100	100	100	100	100	A	A
	②Recovery of heavy faults	40	100	60	100	60	100	55	100	A	A
	③Recovery of power system turbulence	40	100	60	100	100	100	75	100	A	A
Check 5 : Data Management											
Availability of Data recording and analysis for Hydro/DG P.S	① Daily, monthly and yearly operation records inspection records	100	100	80	100	100	100	95	100	A	A
	②Daily, monthly and yearly inspection records	100	100	60	100	100	100	90	100	A	A
	③Event and faults records	100	100	60	100	100	100	90	100	A	A
Check 6 : Understanding of Drawings, sequence and Availability of understanding for Hydro/DG P.S											
	①Drawings of equipment and station	20	100	20	100	40	100	35	100	A	A
	②Sequence diagram	20	40	20	40	40	60	35	45	C-D	C
	③O & M manual	20	100	20	100	40	100	35	100	A	A
	Average	75	97	66	97	83	98	78	97	A-C	A-B

Legend: A 100%, B 80%, C 60%, D 40%, E 20%

Third (3rd) Evaluation Summary of Self-Evaluation for Hydro & Diesel Power Station, Mondul Kiri Electricity, EDC

Date: 2011/2/17	Name	Position in charge	H. Sokhorn Section chief, O'R			Sin Simeng Group Leader			S. Soranda Operator			T. Phally Operator			Corresp. A to E	Evaluated by JICA
			1st	3rd		1st	3rd		1st	3rd		1st	3rd			
Check 1: Plan Planning avility for Hydro/DG P.S (Task Code : TM2, TR2 & TD2)			60	100		60	100		60	100		60	100		3rd	
			60	100		80	100		80	100		80	100		A	
			60	80		60	100		80	100		40	100		90	
Check 2: Operation Operation avility for Hydro/DG P.S (Code TM3, Tr3 & TD3)			100	100		100	100		100	100		100	100		A	
			100	100		100	100		100	100		60	100		A	
			100	100		100	100		100	100		100	100		100	
Check 3: Maintenance Maintenance avility for Hydro P.S (Task Code : TM3, TR3 & TD4)			100	100		100	100		100	100		100	100		A	
			100	100		80	100		80	100		60	100		A	
			80	100		80	100		80	100		60	100		80	
			80	100		80	100		80	100		40	100		85	
Check 4: Trouble Shooting Counter measuring availability for Hydro/DG P.S (Task Code : TM3, TR3 & TD4)			80	100		80	100		80	100		80	100		A	
			60	100		60	100		60	100		40	100		A	
			60	100		60	100		80	100		20	100		65	
Check 5: Data Management Availability of Data recording and analysis for Hydro/DG P.S (Task Code : TM2, TR2 & TD2)			100	100		100	100		100	100		100	100		A	
			100	100		100	100		100	100		60	100		A	
			100	100		100	100		100	100		20	100		100	
Check 6: Understanding of Drawings, sequence and Availability of understanding for Hydro/DG P.S (Task Code : TM3, TR3 & TD4)			60	80		40	80		20	100		40	60		A	
			40	80		40	80		40	40		20	60		B	
			40	80		40	80		40	40		100	60		85	
			78	96		76	97		80	95		60	94		78	
Average																
Legend: A 100%, B 80%, C 60%, D 40%, E 20%																

Third (3rd) Evaluation Summary of Self-Evaluation for Hydro & Diesel Power Station, Mondul Kiri Electricity, EDC

Date: 2011/2/17	Name	T. Setha	Yeb Thav			Not Nin			Eng Tola			Hang Vuthy			Average	Corresp. A to E	Evaluated by JICA	
			Section Manager		Section Chief, DG		Group Leader		Operator		Operator		Operator					
Tasks (Diesel)	Position in charge	1st	3rd	1st	3rd	1st	3rd	1st	3rd	1st	3rd	1st	3rd	1st	3rd			
Check 1: Plan																		
Planning avility for Hydro/DG P.S (Task Code : TM2, TR2 & TD2)	①M & L term plan ②Periodic inspection plan ③Peplacement & repire plan	60	80	60	100	20	80	20	80	20	80	20	100	36	88	A	A	A
Check 2: Operation																		
Operation avility for Hydro/DG P.S (Code TM3, Tr3 & TD3)	①Start/paralle-in/load/stop ②Emergence or quick stop ③Balance operation of water level	100	100	100	100	80	100	80	100	80	100	80	100	88	100	A	A	A
Check 3: Maintenance																		
Maintenance avility for Hydro P.S (Task Code : TM3, TR3 & TD4)	①Daily, weekly, monthly inspections ②Periodic detailed inspection ③Management of tools & equipment ④Management of spare parts	100	100	100	100	100	100	80	100	80	100	80	100	92	100	A	A	A
Check 4: Trouble Shooting																		
Counter measuring availability for Hydro/DG P.S (Task Code : TM3, TR3 & TD4)	①Recovery of light faults ②Recovery of heavy faults ③Recovery of power system turbulence	100	100	100	100	80	100	60	100	60	100	60	100	80	100	A	A	A
Check 5: Data Management																		
Availability of Data recording and analysis for Hydro/DG P.S (Task Code : TM2, TR2 & TD2)	① Daily, monthly and yearly operation records inspection records ②Daily, monthly and yearly inspection records ③Event and faults records	100	100	100	100	100	100	80	100	80	100	80	100	92	100	A	A	A
Check 6: Understanding of Drawings, sequence and																		
Availibility of understanding for Hydro/DG P.S (Task Code : TM3, TR3 & TD4)	①Drawings of equipment and station ②Sequence diagram ③O & M manual	60	100	20	100	20	100	20	100	20	100	20	100	28	100	A	A	A
	Average	82	92	73	93	49	85	39	91	40	89	57	90			A-C	A-B	A

Legend: A 100%, B 80%, C 60%, D 40%, E 20%

Annex -3 Format of Action Plan

Project Name	Division Name
Project for Operation and Maintenance of the Rural Electrification on Micro-hydropower in Mondul Kiri	i Technical Division

1 st Interview for setting Action Plan	2 nd Interview for Interims	3 rd Interview for Final
Date: 14/16-06-2010 Sign:	Date: 6-10-2010 Sign:	Date: 17-1-2011 Sign:

o Summary of Action Plan and Improvement

Name of Power Station	Achievement Level		Measures	Interim Result	Final Result	Rating	JICA Advisor Team Evaluation
	Current Level	Target Level					
1. O'Moleng Hydropower	Level: B-C (average 78%)	Tasks What? Understanding of electrical theory and sequence diagram By When? 31-1-2011	How to do? - To study the symbols and numbers of sequence - To study of wiring diagram - To study of sequence diagram	How's progressing? - To have an examination for level check for all staff - The results was Improved. The test point was 98 in average.	Resulted? - Reaching the action plan to be satisfactory: - To understand the sequence diagram, symbols, numbers and wiring diagram	A B C D E	After their efforts, they can read a sequence and wiring diagram They understood how to apply its now-how and knowledge in the electrical theory and fault analysis.
2. O'Romis Hydropower	Level: B-C (average 76%)	Tasks What? Understanding of electrical theory and sequence diagram By When? 31-1-2011	How to do? - To study the symbols and numbers of sequence - To study of wiring diagram - To study of sequence diagram	How's progressing? - To have an examination for level check for all staff - The results was Improved. The test point was 98 in average.	Resulted? - Reaching the action plan to be satisfactory: - To understand the sequence diagram, symbols, numbers and wiring diagram	A B C D E	After their efforts, they can read a sequence and wiring diagram They understood how to apply its now-how and knowledge in the electrical theory and fault analysis.
3. Diesel Power	Level: C-D (average 52%)	Tasks What? Understanding of electrical theory and sequence diagram By When? 31-1-2011	How to do? - To study the symbols and numbers of sequence - To study of wiring diagram - To study of sequence diagram	How's progressing? - To have an examination for level check for all staff - The results was Improved. The test point was 98 in average.	Resulted? - Reaching the action plan to be satisfactory: - To understand the sequence diagram, symbols, numbers and wiring diagram	A B C D E	After their efforts, they can read a sequence and wiring diagram They understood how to apply its now-how and knowledge in the electrical theory and fault analysis.

Action Plan for Mondul Kiri O&M Technical Support
 Results of Examination for EOM Staff (Diesel, Hydropower Stations)
 2010.10.06

Staff	Total Points	Points		
		Q1	Q2	Q3
O'M Hydro	100	25	50	25
	90	25	50	15
	100	25	50	25
	100	25	50	25
O'R Hydro	100	25	50	25
	100	25	50	25
	100	25	50	25
	90	25	40	25
D.G	100	25	50	25
	100	25	50	25
	100	25	50	25
	100	25	50	25
T.D	90	25	50	15
Total	1270	325	640	305
Average	98	25	49	23

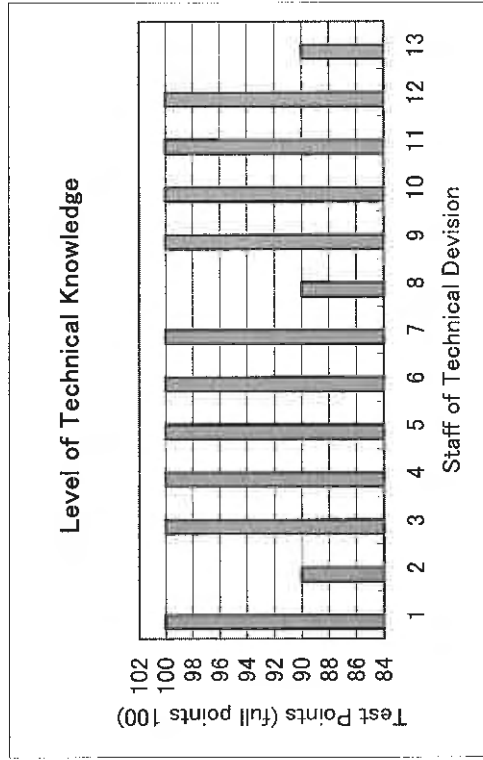

Action Plan for Mondul Kiri Electrification Project, EOM/EDC

(Examination for Electrical Section)

Date: 2010.10.06

You may answer appropriated thought in the following questions.

Please fill in or select your answers into the items

Total points

Name ()

Division ()

The following is "Technical Term for electrical engineering practice", please answer it.

1) Please select in "SI units" for electrical terms as follows; SI units: International System of units

- | | |
|------------------|---|
| 1 Power (P) | 2 |
| 2 Current (I) | 5 |
| 3 Voltage (V) | 1 |
| 4 Resistance (R) | 3 |
| 5 Frequency (F) | 6 |

Points:

- | | | |
|----------------|----------------|----------------------|
| (1) Volt (V) | (2) Watt (W) | (3) Ohm (Ω) |
| (4) $\sqrt{3}$ | (5) Ampere (A) | (6) Hertz (Hz) |

2) How many do you know the "Sequence Numbers" as follows;

- | | |
|---|----|
| 1 Pressure switch or relay | 10 |
| 2 Field circuit breaker switch or relay | 3 |
| 3 Incomplete sequence relay | 4 |
| 4 Voltage relay | 8 |
| 5 Lock out relay | 9 |
| 6 Device or relay for master control | 1 |
| 7 Over speed switch or relay | 2 |
| 8 A.C Under voltage relay | 5 |
| 9 A.C Over current relay | 6 |
| 10 A.C Over voltage relay | 7 |

Points:

- | | | | | |
|--------|--------|--------|--------|---------|
| (1) 4 | (2) 12 | (3) 41 | (4) 48 | (5) 27 |
| (6) 51 | (7) 59 | (8) 84 | (9) 86 | (10) 63 |

3) Please identify and fill in "Electrical Circuit Symbol"

Points:

1 $A = X1 + X2$

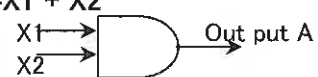

Out put A

2 $A = X1 \text{ or } X2$

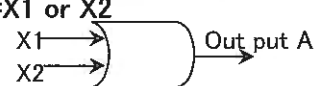

Out put A

3 $A \neq X$ (negative)

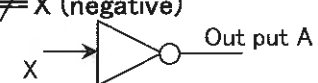

Out put A

a or b-contact ?

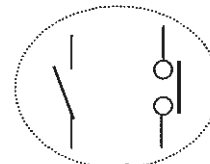

4

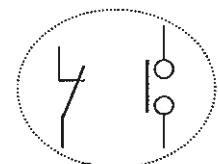

5

- | | | | | |
|---------------|---------------|---------|---------|--------|
| (1) a-contact | (2) b-contact | (3) NOT | (4) AND | (5) OR |
|---------------|---------------|---------|---------|--------|

ផែនការសកម្មភាពសំរាប់គំរោងអគ្គិសនីរ៉ូបូតិកម្ម ខេត្តមណ្ឌលគិរី. EOM/EDC

(វិញ្ញាណប្រលងសំរាប់ផ្នែក គ្រឿងម៉ាស៊ីនអគ្គិសនី)

កាលបរិច្ឆេទ 2010. 10. 6

អ្នកអាចឆ្លើយនូវគំនិតសមស្រប នៅក្នុងសំណួរជាលំដាប់លំដោយខាងក្រោម:

សូមធ្វើការបំពេញ ឬ ជ្រើសរើសយកចំណើយរបស់អ្នកដាក់ចូលក្នុងប្រអប់នៃចំណុចនីមួយៗ

ពិន្ទុសរុប:

ឈ្មោះ: ()

ផ្នែក: ()

តើអ្នកដឹងទេថា លក្ខខណ្ឌវិស្វកម្មបច្ចេកទេសរបស់ផ្នែកគ្រឿងម៉ាស៊ីនអគ្គិសនី មានប្រភេទអ្វីខ្លះ?

1) សូមធ្វើការជ្រើសរើសក្នុងក្រុមនៃ mks របស់លក្ខខណ្ឌគ្រឿងអគ្គិសនីដូចខាងក្រោម: (mks: ឆាឡិការវាស់-គីឡូក្រាម-វិនាទី)

- 1 ថាមពល (P)
- 2 ចរន្ត (I)
- 3 តង់ស្យុង (V)
- 4 រេស៊ីស្តង់ (R)
- 5 ប្រេកង់ (F)

ពិន្ទុ:

- (1) វ៉ុល (V)
- (2) វ៉ាត់ (W)
- (3) អូម (Ω)
- (4) $\sqrt{3}$
- (5) អំពែរ (A)
- (6) Hertz (Hz)

2) តើអ្នកស្គាល់ចំនួនលេខនៃនិមិត្តសញ្ញាតាមលំដាប់ដែលមានដូចខាងក្រោមបានប៉ុន្មានដែរ?

- 1 Pressure switch or relay ()
- 2 Field circuit breaker switch or relay ()
- 3 Incomplete sequence relay ()
- 4 Voltage relay ()
- 5 Lock out relay ()
- 6 Device or relay for master control ()
- 7 Over speed switch or relay ()
- 8 A.C Under voltage relay ()
- 9 A.C Over current relay ()
- 10 A.C Over voltage relay ()

ពិន្ទុ:

- (1) 4
- (2) 12
- (3) 41
- (4) 48
- (5) 27
- (6) 51
- (7) 59
- (8) 84
- (9) 86
- (10) 63

4) សូមបំពេញនិមិត្តសញ្ញាស្មើគ្នារបស់គ្រឿងម៉ាស៊ីនអគ្គិសនី

ពិន្ទុ:

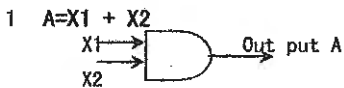

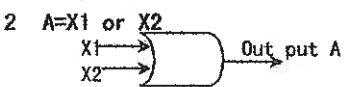

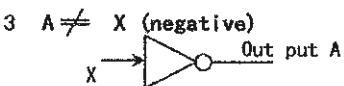

តើមួយណាជាក្នុងតារាង a និង មួយណាជាក្នុងតារាង b?

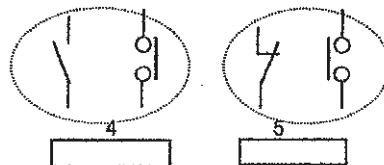

- (1) a-ក្នុងតារាង
- (2) b-ក្នុងតារាង
- (3) NOT
- (4) AND
- (5) OR

Evaluation Plan for Abilities of EUMP

Power Generation

May 2010

JICA Advisor Team

Project for Operation and Maintenance
of the Rural Electrification on Micro-hydropower
in Mondul Kiri

How to Check the Ability

To check the ability is the five level rating system.

Rating: (High) A—B—C—D—E (Low)

Each of them is

A: 100~80% ⇒ Completed the tasks of his work

B: 79~60% ⇒ Almost achieved his tasks required improvement of 1 or 2 items

C: 59~40% ⇒ Possible his tasks under the consultation with station leader

D: 39~20% ⇒ Possible his tasks under the consultation with technical section

E: 19%以下 ⇒ Required further OJT at present and future

The overall points of the above in average will be calculated, and the level of A and B will be achieved.

Result of Achievement Evaluation

Task Item and Code	Detailed Task	1 st Evaluation	2 nd Evaluation	3 rd Evaluation	Comprehensive Evaluation
1) Plan	①				
	②				
	③				
2) Operation	①				
	②				
	③				
3) Maintenance	①				
	②				
	③				
	④				
4) Trouble Shooting	①				
	②				
	③				
5) Data Management	①				
	②				
	③				
6) Understanding of Drawings, Sequence and Documents	①				
	②				
	③				

Annex-1 Evaluation Sheet for Power Generation

Rating : (High) A—B—C—D—E (Low)

Check 1: Plan (Task Code : TM2, TR2 & TD2)

Planning availability for Hydro or DG power stations?

- ①Medium & Long term plan ②Periodic inspection plan ③Replacement & repair Plan

Check 2: Operation (Task Code : TM3, TR3 & TD4)

Operating availability for Hydro or DG power stations?

- ①Start/parallel-in/load/stop ②Emergency or quick stop ③Balance operation of water level

Check 3: Maintenance (Task Code : TM3, TR3 & TD4)

Maintaining availability for Hydro or DG power stations?

- ①Daily, weekly, monthly inspections ②Periodic detailed inspection ③Management of tools & equipment ④Management of spare parts

Check 4: Trouble Shooting (Task Code : TM3, TR3 & TD4)

Counter measuring availability for Hydro or DG power stations?

- ①Recovery of light faults ②Recovery of heavy faults ③Recovery of power system turbulence

Check 5: Data Management (Task Code : TM2, TR2 & TD2)

Availability of Data recording and analysis for Hydro or DG power stations?

- ①Daily, monthly and yearly operation records ②Daily, monthly and yearly inspection records
③Event and faults records

Check 6: Understanding of Drawings, sequence and documents (Task Code : TM3, TR3 & TD4)

Availability of understanding for Hydro or DG power stations?

- ①Drawings of equipment and station ②Sequence diagram ③O & M manual

Annex -2 Format of Self-evaluation sheet

Division, Position _____

Name _____

Date, Place _____

Name of JICA Advisor _____

Task Item and Code Number	Number of Detailed Task	Grade of Evaluation	Reason or Comment	Check by JICA
1)	①	A B C D E		
	②	A B C D E		
2)	①	A B C D E		
	②	A B C D E		
3)	①	A B C D E		
	②	A B C D E		
	③	A B C D E		
	④	A B C D E		
	⑤	A B C D E		
4)	①	A B C D E		
	②	A B C D E		
	③	A B C D E		
	④	A B C D E		
5)	①	A B C D E		
	②	A B C D E		
	③	A B C D E		
	④	A B C D E		
	⑤	A B C D E		

Note: Number of detailed task shall be referred to with Evaluation sheet

**The Project for Operation and Maintenance
of the Rural Electrification on
Micro-hydropower
in Mondul Kiri, Cambodia**

Seminar for Small Hydropower

1. Small Hydropower (Plan)
2. Technical Issue of Hydropower Plant (Design)
3. Mondul kiri Electrification Project (Construction)



***Date: 22 February 2011 at 9:30 – 11:30
Place: Conference room, JICA Cambodia office***

***By JICA Study Team
/Electric Power Development Co., Ltd. (J-POWER)
/The Chugoku Electric Power Co., Ltd. (ENERGIA)***

**Project for Operation and Maintenance of the
Rural Electrification on Micro-hydropower
in Mondul Kiri, Cambodia**

1. Small Hydropower

*By JICA Study Team
/Electric Power Development Co., Ltd. (J-POWER)
/The Chugoku Electric Power Co., Ltd. (ENERGIA)*

1. Small Hydropower (Plan)



Source: Mondul Kiri Project, Cambodia (JICA 2008) /J-Power (Photo)

Source: J-WATER, 2009 and GIAC, 2007

All Rights Reserved. Copyright 2010 J-Power 1

1. Development of Small Hydropower Plant

1.1 Why Introduction and How effectiveness

Potential ability of renewable energy to electric power as a Small hydropower production; the merit of

(1) Economical effect

It can sell or consume by own generated energy (kW)

- Energy cost per project in 2005 = 9.4 J.yen/kWh (approx. 9 cent)
- Weighted average cost = 8.4 J.yen/kWh (approx. 8 cent)

(Source: ANRE report Feb. 2007)

(2) Environmental effect

Hydropower is as a clean energy instead of fossil fuel

Co² emissions intensity in actual,

- Electric power industry : 0.453kg-Co²/kWh(FY2007)
- In Japan : 0.373kg-Co²/kWh(FY2008)

(Source: JEPIC Annual Report, 2009)

All Rights Reserved. Copyright 2010 J-Power 2

1.1 Why Introduction and How effectiveness

(3) Save energy effect:

Applying subsidy support (10 to 50 %) by the Government, and then Public open by the law of RPS (Renewable Portfolio Standards)

1.2 How many capacity is a small scale hydropower plant ?

The power utility companies in Japan generally definite that the out put of less 10,000kW is a small hydropower.

Other hand, it is clearly classified a less 1,000kW vs. over 1,000kW under the law of Japan.

All Rights Reserved. Copyright 2010 J-Power 3

Defined Small Hydropower in Foreign Country

No.	Countries	Capacity (kW)	Remarks
1	The Philippines	Less 5,000	National Electrification Administration
2	Thailand	Less 6,000	National Energy Administration
3	Indonesia	1,000 to 2,000	Government development plan
4	Japan	Less 3,000	Promotion Act for introduction of Electric into Rural Areas
5	USA	Less 1,500	Law were amended to quicken the procedure for approving development plans with the small scale plants
6	Sweden	Less 1,500	Subsidies are offered for a small scale plants
7	France	Less 4,500	Approved by provincial level for the small scale plants

All Rights Reserved. Copyright 2010 J-Power 4

1.3 Where the power station can install



Ordinary river

Soil serving dam

Irrigation canal

Waterworks

All Rights Reserved. Copyright 2010 J-Power 5

1.3 Where the power station can install



Sewerage system

River maintenance water

Generation discharge

Cooling water at factory & Building

All Rights Reserved. Copyright 2010 J-Power 6

1) Installed location (Site by Site)



(1) Ordinary river

- Classified : Class A river (Kyoto pref.)
- Head 1.74m, Discharge 0.55m³/s,
- Output 5.5kW
- Operation : December, 2005

Source: Project for NEDO's subsidy Support



(2) River maintenance flow

- Classified: River maintenance (Gunma pref.)
- Discharge 0.329m³/s,
- Output 230kW
- Operation : October, 2005

Source: Project for NEDO's subsidy Support

All Rights Reserved, Copyright 2010 J-Power 7

Installed location (Site by Site)



(3) Soil saving dam

- Classified : Soil saving dam (Kumamoto pref.)
- Head 14.38m, Discharge 2m³/s,
- Output 190kW
- Operation : April, 2005

Source: Project for NEDO's subsidy Support



(4) Waterworks

- Applying natural head of water supply pit (Osaka pref.)
- Head 35m, Discharge 0.48m³/s,
- Output 129kW
- Operation : January, 2007

Source: Project for NEDO's subsidy Support

All Rights Reserved, Copyright 2010 J-Power 8

Installed location (Site by Site)



(5) Irrigation water

- Applying dead head of irrigation (Yamanashi pref.)
- Head 77.5m, Discharge 0.5m³/s,
- Output 320kW
- Operation : March, 2007

Source: Project for NEDO's subsidy Support



(6) Generation water

- Applying discharge water (Gifu pref.)
- Head 8m, Discharge 2.3m³/s,
- Output 150kW
- Operation : July, 2005

Source: Project for NEDO's subsidy Support

All Rights Reserved, Copyright 2010 J-Power 9

(1) Installed at Soil Saving Dam



· Soil block
· prevention of river erosion



All Rights Reserved, Copyright 2010 J-Power 10

Installed at Soil Saving Dam

FK, P.S.(Okayama Pref.)
P=180kW, Q=2.6m³/s, He=9.7m,
E=847MWh

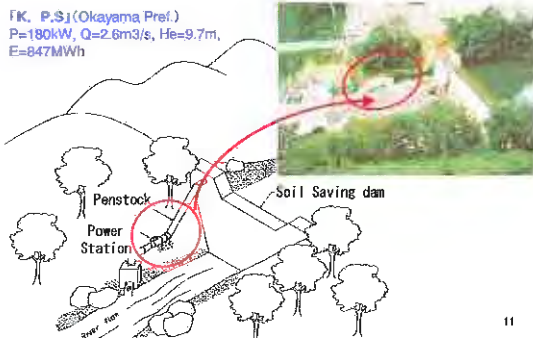

Penstock
Power Station
Soil Saving dam

All Rights Reserved, Copyright 2010 J-Power 11

(2) Installed at irrigation canal

Flow of Gradual Sloop (Falling work)



Flow of Steep Slope



All Rights Reserved, Copyright 2010 J-Power 12

Installed at Irrigation Canal

POWER

「Y. Power Station」(Nlgata Pref.)
 $P=18\text{kW}$, $H_e=2.24\text{m}$, $Q=2.46\text{m}^3/\text{s}$

Irrigation canal

Power Station

All Rights Reserved. Copyright © 2010 J-Power

13

(3) Installed at Utilities Waterworks

POWER

Waterworks

Intake water

Water Purified plant

Reduce valve

Water distributor

Turbine/Gen.

Industrial Water

Water treatment facility

Reduce valve

Discharge pit

Sewerage system

Turbine/Gen.

Surplus pressure in the pipeline will be applied for generation

All Rights Reserved. Copyright © 2010 J-Power

14

Installed at Utilities Waterworks (for example)

POWER

Main

Reduce Valve

Bypass

Turbine Gene.

All Rights Reserved. Copyright © 2010 J-Power

15

(4) Installed at Sewerage

POWER

Drains/Inlets

Sedimentation

First Sedi.

Reaction Tank

Final Sedi.

Mixing Chlorine

Discharge

Turbine/Gen.

All Rights Reserved. Copyright © 2010 J-Power

16

Installed at Sewerage

(Morigasaki Water Recycle Center)

POWER

All Rights Reserved. Copyright © 2010 J-Power

17

1.4 How to consume & interconnect

POWER

- (1) Rule of technical matter must be in accordance with [Standards of Power Interconnection (JEAC9701-2006)], Public regulation.
- (2) In case of alternative plan, the applicant may negotiate with power utility company, Japan.
- (3) Type of interconnection
 - Case-1: Power only receive and no send from/to distribution line
 - Case-2: Power receive and send from/to distribution line
 - Case-3: Power only send to distribution line

All Rights Reserved. Copyright © 2010 J-Power

18

Power Interconnection



There are 3 cases of the interconnection between the Power station and public power system.

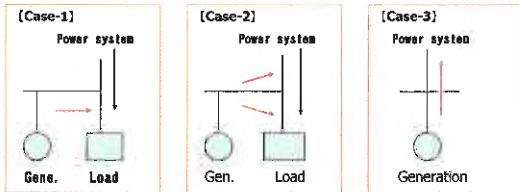

All Rights Reserved. Copyright 2010 J-Power

19

2. Characteristics of Small Hydropower



- (1) There is a different to develop the potential ability of the project: between near towns/villages vs. remote mountain area.
- (2) There is a different the construction cost: per kWh depending on the project locations site by site. (Hydro-valley plan, Japan : 0.5 ~ 10 US\$/kWh)
- (3) Law application of difficulty is different depending on the project sites: because of river control and protection.

All Rights Reserved. Copyright 2010 J-Power

20

- (4) There is no problem or equal on technical matter for development of the project:  such as land acquisition, move of houses, environmental preservation and equipment specifications, etc.

3. Merits of Development

- (1) **Economical point:** It is necessary to be made a priority on the project site, because of easy and economical maintenance cost.
- (2) **Easy application of law:** It is necessary to get the approval of the government, because of spending a time and cost, etc.
- (3) **Applying of Subsidy and/or Support system**
- (4) **Making consensus for residents and parties**

All Rights Reserved. Copyright 2010 J-Power

21



All Rights Reserved. Copyright 2010 J-Power

22

**Project for Operation and Maintenance of the
Rural Electrification on Micro-hydropower
in Mondul Kiri, Cambodia**

**2. Technical Issue of
Hydropower Plant (Design)**

*By JICA Study Team
/Electric Power Development Co., Ltd. (J-POWER)
/The Chugoku Electric Power Co., Ltd. (ENERGIA)*

Electricity of Mondul Kiri (EOM), EDC Technical Issue of Hydropower Plant for Mondul Kiri Electrification Project



Source: Mondul Kiri Project, Cambodia (JICA 2008) J-Power (Photo)
Prepared: Electric Power development Co., Ltd. (J-Power), February 2011

POWER

All Rights Reserved. Copyright 2018 J-Power 1

1. Process from Planning to Operation in Hydropower Development **POWER**

- **Investigation & Planning**
 - Reconnaissance Study (Preliminary Study)
 - Feasibility Study
- **Design**
 - Detailed Design
- **Construction**
 - Civil Works
 - Hydro mechanical and Electrical Works
 - Transmission line/distribution line
- **Operation & Maintenance**
 - Operation of Hydropower Plants
 - Environmental Monitoring

All Rights Reserved. Copyright 2018 J-Power 2

1.1 Flow chart of project evaluation (Feasibility study) **POWER**

```

    graph TD
      C[Cost (construction, O&M): C] --> CF[Calculation of cash flow (B-C)]
      B[Revenue (electricity sale): B] --> CF
      CF --> NPV[Calculation of NPV (B-C) and B/C]
      NPV --> D{NPV(B-C) > 0 ?  
and B/C > 1 ?}
      D --> F[Project is feasible]
      D --> NF[Project is not feasible]
  
```

All Rights Reserved. Copyright 2018 J-Power 3

1.2 Type of Hydropower Station **POWER**

In a general, Hydropower generation systems are classified according to the location and type of structure based on the topographic conditions:

- **Location of structure**
 - 1) Waterway type power station (Run-of-river type),
 - 2) Dam type power station,
 - 3) Dam with waterway type power station
 - 4) Using agricultural water way facilities (micro hydro)
- **Type of structure**
 - 1) Above ground type,
 - 2) Semi-ground type,
 - 3) Underground type

All Rights Reserved. Copyright 2018 J-Power 4

Types of Hydropower Plant **POWER**

```

    graph LR
      HG[Hydro power generation] --> CT[Conventional type]
      HG --> PST[Pumped storage type]
      CT --> CR[Conduit (Run-of-river) type]
      CT --> DR[Dam (Reservoir) type]
      CT --> DC[Dam & Conduit type]
      PST --> PPS[Pure pumped storage type]
      PST --> PNF[Pumped and natural flow storage type]
  
```

All Rights Reserved. Copyright 2018 J-Power 5

Conduit Type (Run-of-River Type)

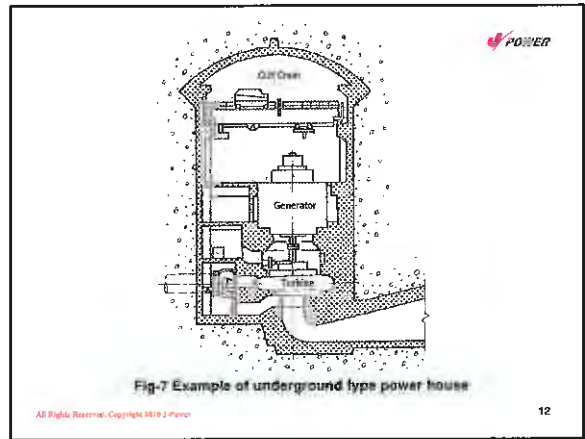
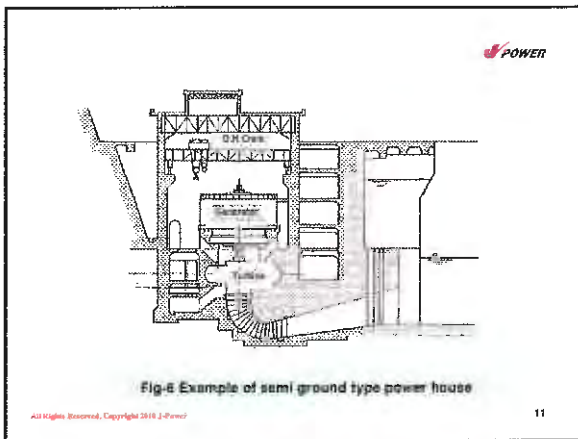
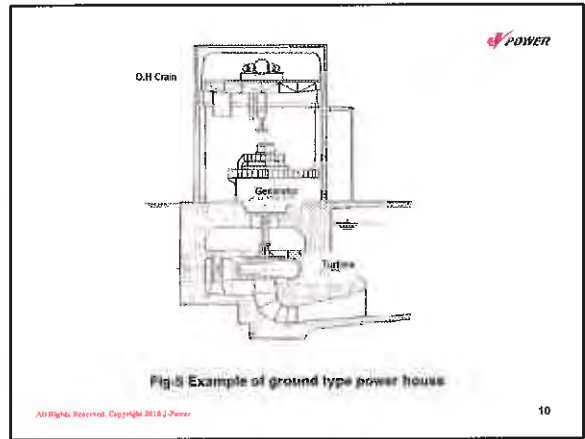
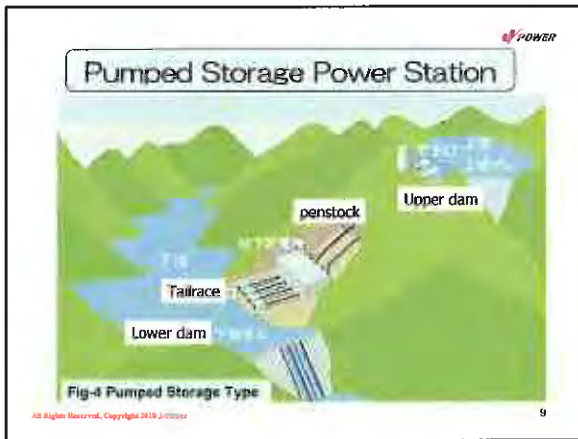
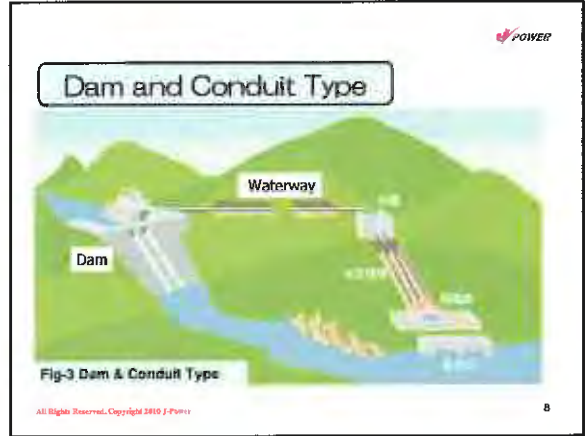
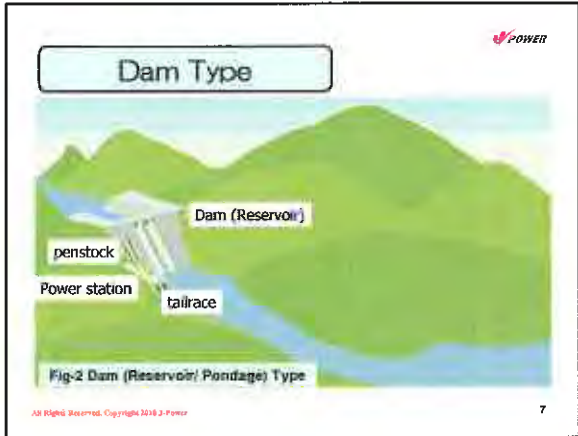

Fig-1 Run-of-River Type

All Rights Reserved. Copyright 2018 J-Power 6



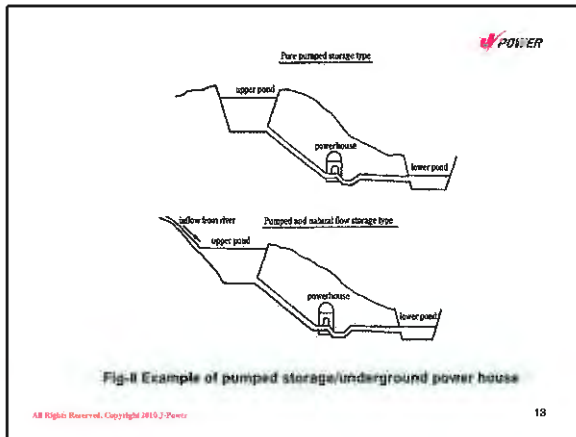
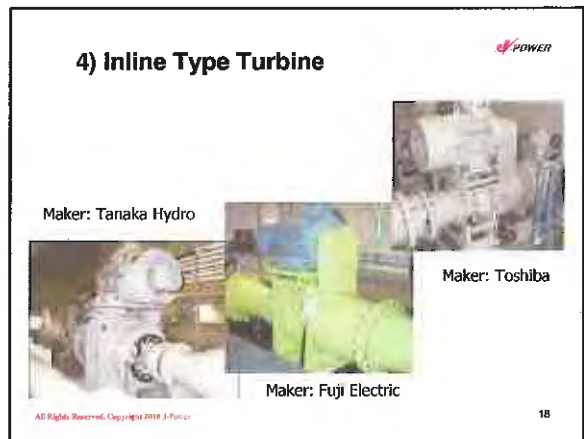
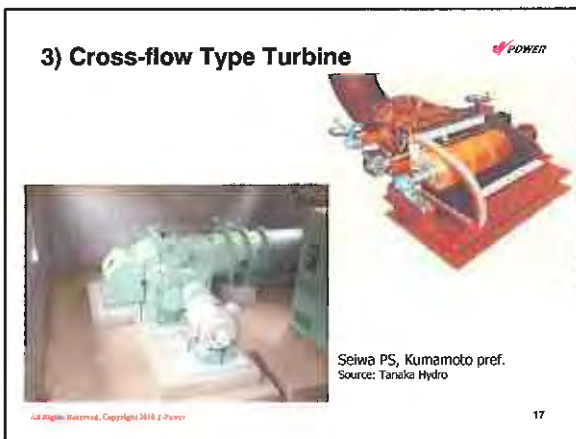
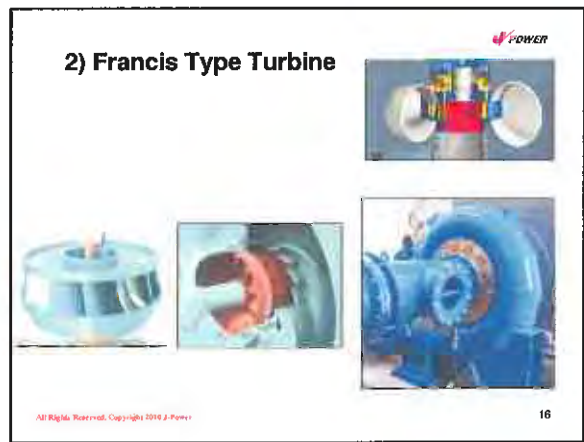
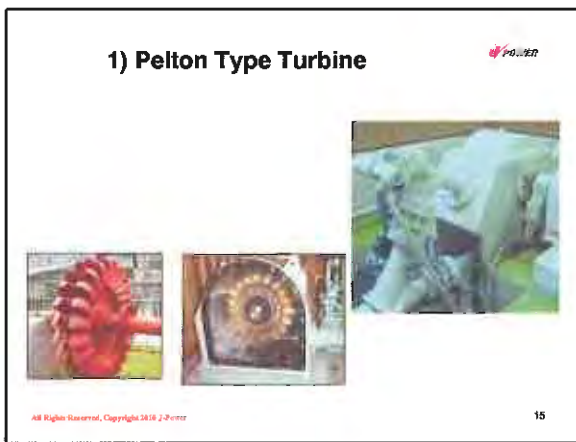

Table -1 Classification of Turbine Type

Type	Turbine	Characteristics
Impulse Type	Pelton Turbine	<ul style="list-style-type: none"> • High head & efficiency at Partial • High speed & low cost • High efficiency at Partial
	Turgo impulse turbine	
	Cross-Flow turbine	
Reaction Type	Francis turbine	<ul style="list-style-type: none"> • High reliability & efficiency
	Diagonal Flow (Deriaz) Turbine	<ul style="list-style-type: none"> • Wide operation & low head range
	Propeller (Kaplan) Turbine	<ul style="list-style-type: none"> • Wide operation range & low head range
	Tubular (Bulb) Turbine	
Reverse Pump Turbine	<ul style="list-style-type: none"> • Low cost & head & simple construction 	

All Rights Reserved, Copyright 2018 J-Power 14



5) Open Type Turbine

Spiral flow type



Under flow type



Upper flow type



POWER

All Rights Reserved, Copyright 2019 J-Power

19

6) Other Type Turbine

Reverse Pump Turbine



Packaged Type Bulb Turbine



Turgo Impulse Turbine



POWER

All Rights Reserved, Copyright 2019 J-Power

20

2. Design of Hydropower Facility for Mondul Kiri Power Station, EDC

Hydropower station is consisted,

- 1) Civil facility:** Dam (weir), Intake, head tank, waterway, spill way and tailrace (outlet)
- 2) Electro-mechanical facility:** Turbine, generator, control equipment, auxiliary equipment and step-up transformer
- 3) Transmission line facility:** transmission lines, distribution lines, step-down transformer and substation

POWER

All Rights Reserved, Copyright 2019 J-Power

21

2.1 Civil Facilities

1) Dam and intake facilities



POWER

All Rights Reserved, Copyright 2019 J-Power

22

2) Sedimentation



POWER

All Rights Reserved, Copyright 2019 J-Power

23

3) Waterway (headrace)



POWER

All Rights Reserved, Copyright 2019 J-Power

24

4) Head tank

Head Tank & intake

Overtow to Spill way

POWER

All Rights Reserved, Copyright 2019 J-Power

25

5) Gate

Water level measurer

intake gate

POWER

All Rights Reserved, Copyright 2019 J-Power

6) penstock

Penstock

Penstock

POWER

All Rights Reserved, Copyright 2019 J-Power

27

7) Spillway and Tailrace (Outlet)

Spill way

Tailrace (outlet) (Q/Romle)

POWER

28

2.2 Electro-mechanical Facility

2.2.1 Water Turbine

1) Selection of Water turbine type

The water turbines are categorized two type impulse and Reaction type turbines. (Table-1)

Turbine type will be mainly selected by two factor of Head (m) and discharge (m^3/s).

Turbine discharge will be determined by yearly duration curve as shown Fig-9, and head will be also determined by the topographical condition and located powerhouse. Then, the turbine type will be selected in considering Fig-10.

POWER

All Rights Reserved, Copyright 2019 J-Power

29

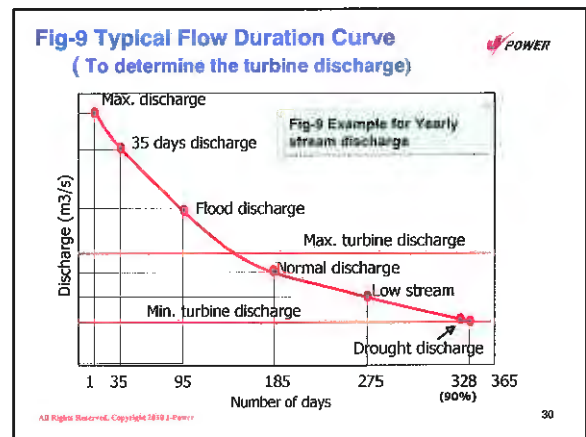

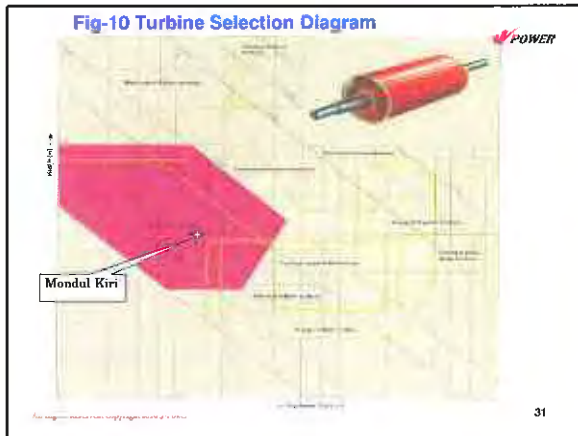

2) Cross Flow Turbine(1/2)

(1) Small hydropower

The Cross flow turbines have a long history of growth, since their initial development, and several hundred units have already been put into operation as small hydraulic turbines.

(2) Simple construction

The cross flow turbine has a very simple construction and is suitable for use in small power plant, so it is advantageous in cost and easier maintenance.

(3) Partial operation

Since cross flow turbine has relatively high efficiency under operation at partial discharge, it is suitable for small capacity and medium and low heads (5 to 100m) refer to Fig-1.

POWER

32

4) Main construction

As shown in Fig2, the main construction consist of the runner, main shaft, guide vanes, runner case housing, etc.

5) Draft tube and Water flow

There is normally no draft tube in the cross-flow turbine outlet, so that getting rid of cavitation pitting than reaction type turbine. (But there is a type of cross-flow turbine with draft.)

Water flow from the penstock is brought to the runner through the guide vane. The water moves through the inner side of the runner, passage through the runner towards the outer side of runner and then discharged, while parts of the water to the runner is discharged from the outer side of runner to the tailrace.

POWER

33

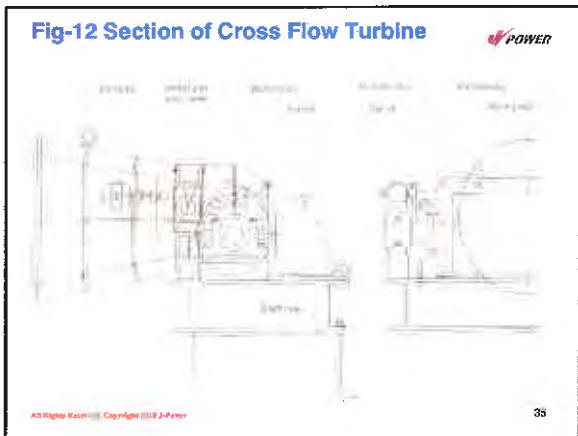
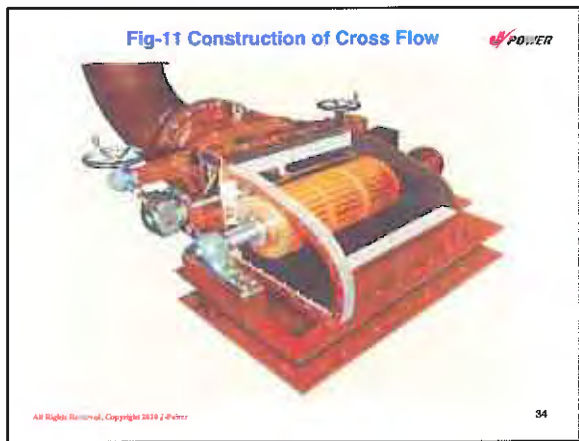

Construction of Cross Flow Runner, O'Molen 



All Rights Reserved, Copyright 2019 J-Power

37

Standardized range for Cross-flow turbine 

- Net head** : 7 ~ 100 m
- Discharge** : Approx. 0.15 ~ 5.0 m³/ sec
- Output** : Approx. 50 ~ 1,000 kW
- Speed** : 100 ~ 1,000 rpm (50Hz),
100 ~ 1,200 rpm (60Hz)
- Specific speed**: 40 ~ 200 m-kW

All Rights Reserved, Copyright 2019 J-Power

38

210kW Cross-flow Hydro Turbine, Japan 



All Rights Reserved, Copyright 2019 J-Power

39

3) Head and Discharge (1/2) 

- (1) The application range of the cross flow turbine is such that the head is within 7 to 100 m, the discharge is within 0.1 to 6 m³/ sec, and the output is less than 1,000 kW.
- (2) In the case of head more than 100 m, a special design would be required for turbine.
- (3) The net head (H_e) of cross flow turbine is specified as a head between intake water level (IWL) and center of runner level (CRL) as shown below;

for example: O'Moleng power station

$$H_e = IWL - CRL - H_{\text{loss (penstock loss)}} \\ = 614\text{m} - 593.7\text{m} - 1.6\text{m} = 18.7\text{m}$$

- (4) Since the runner will rotate in atmospheric air like Pelton turbine, the water discharge from the runner can not be used as energy.

All Rights Reserved, Copyright 2019 J-Power

40

(5) In case of large discharge (Q_{max}) is specified, the turbine output (kW) decreases or sometimes the unit requires to stop the operation due to occurrence of cavitation and vibration at low efficiency zone in the dry season. In general, the allowable operation range of discharge (m³/s) is as follows;

- **Francis turbine** : 100 ~ 40 %
(Partial load Francis runner : 100 ~ 25 %)
- **Tubular turbine** : 100 ~ 25 %
- **Pelton turbine** : 100 ~ 20 %
- **Cross flow turbine** : 100 ~ 15 % (with 2 G.Vs)

All Rights Reserved, Copyright 2019 J-Power

41

4) Specific Speed of Turbine 

(1) Specific speed (N_s)

The specific speed of similar runner in a group is expressed by the rotational speed (N) obtained when one runner has the effective head $H=1\text{m}$ and output $P=1\text{kW}$.

$$N_s = N \times P^{1/2} / H^{5/4} \text{ ----- (1)}$$

As seen from equation (1), as long as the rotational speed (N) has been determined, the N_s can be calculated by using the H and P .

By comparing the obtain specific speed for range of various turbine, the type desired can be roughly determined in the Figure-13.

All Rights Reserved, Copyright 2019 J-Power

42

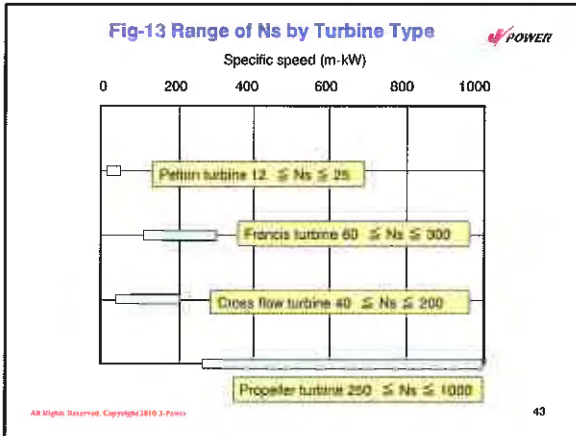

(2) Maximum specific speed 

The Fig-4 was prepared on the basis of experiments and actually proven example and shown the applicable range for each turbine type corresponding to the limit of specific Speed (Ns). For water turbines, the speed increase is primarily limited by the balance which also occurs in other hydraulic machine. For simply determining the speed while taking into account the prevention of harmful cavitation, it is recommended the following formulas be used for calculating the applicable maximum specific speed.

$$N_s \text{ max.} \leq 650 H^{-0.5} \quad (2)$$

e.g. O'Romis Turbine: $N_s \text{ max.} = 650 \times 18.7^{-0.5} = 128 \text{ m-kW}$
(Design $N_s = 92 \text{ m-kW}$)

All Rights Reserved, Copyright 2018 J-Power 44

5) Efficiency of Cross Flow Turbine (1/2) 

(1) In order to utilize the high efficiency during partial discharge, the guide vane (G.V) located over the full width of the runner is divided into two portions with one-third (1/3) or two-thirds (2/3) width. According to discharge in the width of the G.V is selected $1/3 + 2/3 = 3/3$, $2/3$ or $1/3$ to obtain the characteristics shown in Fig-5.

(2) The change of the guide vane for high efficiency operation zone will be made manually in turbine runner against river flow during dry season.

(3) However, where the effective head is greater than 70m or the output smaller than 50kW, the guide vane switching method stated above cannot be easily applied for structural reasons (monolithic G.V type).

All Rights Reserved, Copyright 2018 J-Power 45

Fig-14 Turbine Efficiency Model 

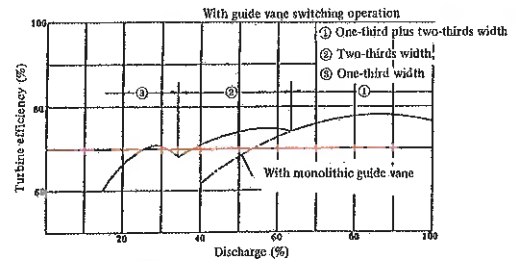
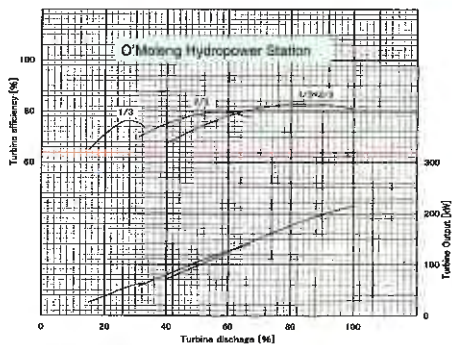

Fig-14-1 Turbine Efficiency Curve 



5) Efficiency of Cross Flow Turbine (2/2) 

(4) Variable discharge characteristics are about 15% of the rated discharge for G.V switching construction and about 40% for monolithic G.V construction.

(5) Also, the variable head range is considered approximately 70% of the maximum head.

(6) The cross flow turbine is normally installed above the tailrace water level in order to prevent the runner from being submerged during operation excepting other specified design.

(7) In the case of turbine speed is low, as with a cross flow turbine, generator speed can often be increased over that of the turbine by adopting a speed-increasing gear from the viewpoint of economy.

All Rights Reserved, Copyright 2018 J-Power 48

6) Construction of Speed Inserter



(1) Parallel shaft helical gears are normally used for the speed inserter, and anti-friction bearing are employed as bearings and also for supporting the thrust of gears.

(2) For coupling the machine with turbines or generators, flange type flexible couplings are normally employed but geared coupling are sometimes adopted in the range of large-capacity. As lubricating method in the inserter, the built-in oil type is normally applied but, the oil-circulating type is sometimes applied for the large-capacity.

(3) The speed inserter is placed between the turbine and generator to enhance the economic design of the generator when the speed of the turbine is within a range of less than 600 rpm (50Hz) or 720 rpm (60Hz).

All Rights Reserved, Copyright 2018 J-Power

49

Speed Inserter for O'Moleng Hydropower



All Rights Reserved, Copyright 2018 J-Power

50

7) Turbine Output



(1) As the effective head and discharge of the power station being planned have been roughly determined in the case study, the turbine output can be easily obtained from the following formula, if turbine efficiency is assumed;

$$P_t \text{ (kW)} = 9.8 Q \cdot H \cdot \eta t \text{ ----- (1)}$$

Where,

P_t : turbine output (kW), 9.8: constant, Q : discharge (1.45 m³/s),
 H : effective head (18.7m), ηt : turbine efficiency (70~77%)

i.e. Efficiency : Cross flow turbine: 70 ~ 77 %
 Pelton turbine: 82%
 Francis turbine: 84%
 S-type tubular turbine: 84%

(2) As seen from formula (1), the turbine output is calculated for O'Moleng power station;

$$P_t = 9.8 \times 1.45 \times 18.7 \times 0.7 = 186 \text{ kW} \sim 204.6 \text{ kW}$$

All Rights Reserved, Copyright 2018 J-Power

51

8) Turbine Guide Vane



(1) Turbine guide vanes (G.V) can control the water flow, it means that the output of turbine will be determined depending on the G.V opening.

The G.V is divided into 2 pieces as a 1/3 and 2/3, so that the output can obtain 1/3, 2/3 and 3/3 of the rated output.

All Rights Reserved, Copyright 2018 J-Power

52

Guide Vane, Mondul Kiri Turbine

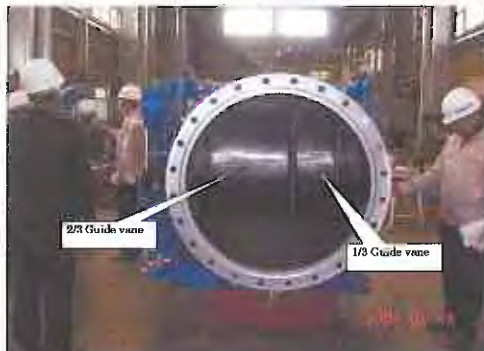

All Rights Reserved, Copyright 2018 J-Power

53

Guide Vane Servo-motor Unit



All Rights Reserved, Copyright 2018 J-Power

54

9) Analysis of Transient Phenomena



in assuming safe and reliable operation of the power station, measures required for the items listed below are primarily taken at the generating equipment side.

(1) Pressure rise in penstock during sudden load rejection

- Water pressure rise in penstock will be occurred during sudden load rejection such as emergency trip of electrical and mechanical troubles. Then, an accident necessitating the interruption of power transmission occurs during the operation of power plants.
- The circuit must be disconnected by circuit breakers located between the main circuit and power transmission line for separating the turbine and generator facility.

All Rights Reserved, Copyright 2010 J-Power

55



- This is sudden load rejection. In this case, the operation of the unit must be immediately stopped by close of the guide vanes or inlet valve.

This operation of the guide vanes causes water Hammer in the penstock, thereby rising water pressure in the penstock.

- Therefore, the closing time of the guide vane must be set in such a manner that the pressure rise in the penstock will not exceed the allowable maximum design values in withstand of the penstock.

All Rights Reserved, Copyright 2010 J-Power

56

(2) Pressure rise during runaway speed



- This transient phenomena becomes problematic if the discharge characteristics of the runner type, such as Francis, Cross flow or Propeller type turbine, cause a pressure rise in the penstock after sudden load rejection in a power station having a relatively long time for the guide vanes.

- That is, if speed of runner begins to increase to runaway speed, then the discharge increases or decreases depending on the runner characteristics. If the change in this discharge per unit period of time is large, then a pressure rise occurs in the penstock.

All Rights Reserved, Copyright 2010 J-Power

57

(2) Pressure rise during runaway speed



- The unit reaches runaway speed (N_r) for a state where the Closing time of guide vanes is relatively long after a sudden load rejection and the moment of inertia of rotor is small, or where the guide vanes fail to close after sudden load rejection.

Runaway speed

- 1) Pelton turbine: 1.7 ~ 2
- 2) Francis turbine: 1.6 ~ 2.3
- 3) Cross-flow turbine: 1.6 ~ 2.5
- 4) Kaplan turbine: 2 ~ 3.2
- 5) Tubular turbine: 2.5 ~ 3

All Rights Reserved, Copyright 2010 J-Power

58

Name Plate of Hydraulic Turbines



All Rights Reserved, Copyright 2010 J-Power

59

2.2.2 Inlet Valve



Inlet valve is used for the following purposes and to be installed between the end of penstock and turbine.

- 1) Water-open or close during ordinary start and stop the turbine.
- 2) Flow interruption in the event of stalled guide vane movement
- 3) Water-close during maintenance such as inside inspection of turbine

All Rights Reserved, Copyright 2010 J-Power

60

1) Type and Selection



Butterfly valve : with head of less than 150 m
Sluice valve : with head of less than 200 m

2) Operation Method

Manual type : where operation of power station is made at the machine side by hand.
Oil or Motor type : where operation of power station is made by one man control.
 In addition to the operation method the above, closing operation will be applied by a counter weight under both ordinary and emergency cases without relaying upon motor or oil pressure.

Fig-15 Construction of Inlet Valve (butterfly type)

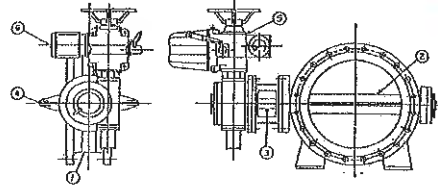

No.	Part name	Material
1	Valve body	Rolled steel plate for ordinary construction or carbon steel.
2	Valve element	Same as above.
3	Valve shaft	Stainless steel, carbon cast steel or cast iron steel for mechanical construction.
4	Valve seat	Rubber.
5	Speed reducer	
6	Motor	

Butterfly Inlet valve, Mondul Kiri Project



2.2.3 Governor



The governor (GOV) is used for speed control and frequency control which means adjusting the output (load control).
 The GOC is classified as follows.

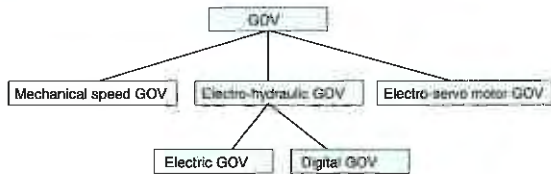

1) Speed Governor Control



(1) Speed control

When the output of the unit is in balance with the load, the unit is operated at the rated rotational speed, so that power with rated frequency of 50Hz (or 60Hz) is supplied to the system. The GOV under those conditions operate in a neutral state without performing positive speed control.

(2) Load control

In this event, if the load increases or decreases and the balance with output is lost, then the rotating speed deviates from the rated values and falls or rises. This causes fluctuations in the frequency at the same time and, if this situation is not recovered, power supply may be sometimes poor quality, depending on the change in speed (frequency).

The GOV quickly responds to such changes in speed and perform control operation to always maintain the turbine rated speed.

2) Dummy Load Governor Control (DL GOV)

The difference of basic function against to speed GOV is that the dummy load GOV has no speed control function, but DL GOV can control the system load by dummy heaters (kW) as like consumers' loads.

(O'Romis and O'Moteng P.S have a dummy load of 210kW)

So-call peak operation is one of the output control operations, in which the relevant power station is subordinated to other power generating facilities in the system and the turbine output of the power station is increased or decreased or its operation started or stopped in response to rise or falls in the system loads.

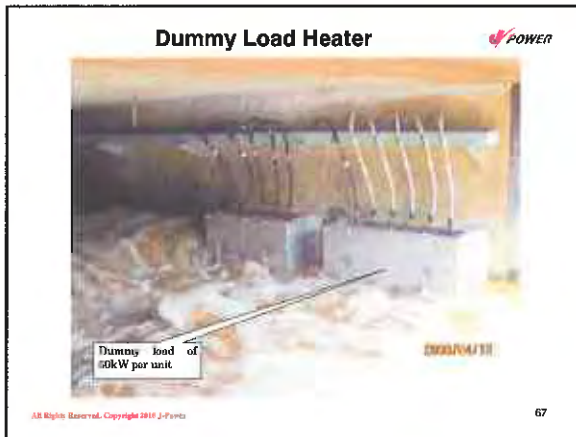

2.2.4 Generator

1) Type

There are two types of generators such as **Synchronous generator** and **Induction generator**, Generally, induction generator has a simple construction with no exciter system so that it is easy maintenance and economy than synchronous generator, but induction generator can not be used for independent operation and causes a large rush current at the moment when parallel into the system. Therefore, induction generator will be applied the following conditions;

No required for independent operation and connecting to the large power system.
Considering rush current effect at the moment of paralleling in the system

POWER

68

2) Characteristics

Characteristics	Induction generator	Synchronous generator
1. Independent operation	No independent operation due to required excitation from system	Independent operation is possible
2. Excitation system and Power factor (p.f)	No exciter and no adjustable, then rush current is big	Exciter is required and p.f can be adjusted.
3. Synchronization	No required synchronization	Required synchronizer, and parallel-in by C.B
4. Stability	Stable and no step-out from the system	Step-out from the system Due to load fluctuation
5. Maintenance	Easy maintenance than synchronous generator	Necessary maintenance

POWER

69



3) Rated Frequency (F)

- The frequency of generator will be applied with 50HZ or 60Hz in the each countries, Mondul Kiri power system applied 50Hz according to the Cambodian power system.

4) Rated Rotation Speed (N)

- The rotational speed is an important factor and is closely related to the external dimensions, weight and characteristics of the generator. The high speed generator is advantageous economy and efficiency performance than low speed generator. Refer to Table-2 .

POWER

71

Table-2 Speed Selection

No. of poles	50 Hz	60 Hz	No. of poles	50Hz	60 Hz
6	1,000	1,200	32	188	225
8	750	900	36	167	200
10	600	720	40	150	180
12	500	600	48	125	150
14	429	514	56	107	129
16	375	450	64	94	113
18	333	400	72	83	100
20	300	360	80	75	90
24	250	300	88	68	82
28	214	257			

POWER

72

8) Insulation Class



The stator coils are made of insulated wires wound the required number of turns. The insulation of stator coil is normally applied Class B and F. Recently, Class F insulation is employed for reducing the size of machine with economical reasons.

(1) **Class F Insulation:** Stator winding 100°C, Rotor winding 110°C for temperature rise limit and limited max temperature be 155 °C.

(2) **Class B Insulation:** Stator winding 80°C, Rotor winding 90°C for temperature rise limit and limited max temperature be 130 °C.

All Rights Reserved, Copyright 2010 J-Power

79

2.2.5 Exciter System



For synchronous generator, an exciter system is required for supplying field currents to generator by which the constant terminal voltage can be maintained in response to load fluctuation.

1) Type of Exciter Method

Recently, brushless exciter and direct thyristor excitation method are mainly employed.

The brushless type is a good maintainability and widely utilized in small-scale hydropower plant.

All Rights Reserved, Copyright 2010 J-Power

80

2) Brushless Exciter



➤ The brushless type consists of an AC exciter directly coupled to the main generator, a rotary rectifier and separately provided thyristor type automatic voltage regulator (AVR).

➤ An exciter is always employed in synchronous generator for preventing a change of generator terminal voltage due to fluctuations of the load or rotating speed.

3) Automatic Voltage Regulator (AVR)

AVR is devices for automatically regulating the field current in order to make the generator voltage constant, and the continuous operating by using semiconductors unit.

All Rights Reserved, Copyright 2010 J-Power

81

2.2.6 Bearing



Kind of bearing and their lubrication method can be classified as follows.

(1) Anti-friction bearing

Grease type

Built-in type (Roller type)

Forced lubrication type

(2) Sleeve bearing

Built-in type (oil ring or oil disc type)

Forced lubrication type

Normally, anti-friction type bearing is used for small machine less than 500kVA, and built-in type sleeve bearing for machine with capacity of 500 to 1,000kVA and forced lubrication method for machine with the large capacity larger than those.

All Rights Reserved, Copyright 2010 J-Power

82

Turbine Shaft Bearing



All Rights Reserved, Copyright 2010 J-Power

83

2.2.7 Control System



The Control system is applied for each method,

- (1) Supervisory control methods,
- (2) Operation control method, and
- (3) Output control method

1) Supervisory Control Methods

There are three (3) supervision and operation system in power station;

(a) Continuous supervisory control method

Operators are always resident at the power station to supervise and control the equipment such as starting and stopping operation, etc.

All Rights Reserved, Copyright 2010 J-Power

84

(b) Remote continuous supervisory control method
 The power station is unmanned controlled, but operators are always stationed at control center to supervise the operation condition by remote control system.

(c) Occasional supervisory control method
 The power station is unmanned controlled, and operators are not always stationed at control center, but they will supervise the operation condition as required by patrol/inspections.

In case of small-scale hydropower plant in isolated area, the Continuous supervisory control method (a) is normally employed and also dam and intake facilities are maintained by the operators.

All Rights Reserved. Copyright 2010 J-Power 85

2) Operation Control Method

(a) Manual operation method
 Start-up, shut down and other controls are performed manually at site by the judgment of operators.

(b) One-man control method
 Automatic start up or shut down is performed by master control switch at control board.

(c) Full automatic control method
 The turbine/ generator is automatically started or stopped by predetermined conditions as required water level, operation hours and so forth without operators.

All Rights Reserved. Copyright 2010 J-Power 86

3) Protection and Instrumentation

The protection and instrumentation are important items for the safe operation of the plant.

They should be designed depending on the duty or capacity (kW) of the plant, or rather, small scale hydropower generation will provide simple and easy protection and instrumentation.

All Rights Reserved. Copyright 2010 J-Power 87

Shop Test for Control panels



All Rights Reserved. Copyright 2010 J-Power 88

4) Control panel



All Rights Reserved. Copyright 2010 J-Power 89

4) Synchronous Parallel-in Unit

(1) When the synchronous generator is connecting to the power system, the synchronization is required between the generator and power system in the following conditions.

- The voltage is the same as between them
- The frequency is the same
- The phase is the same

(2) When the parallel-in by the automatically, a synchronism check relay (25) with speed matcher and voltage balance unit are required.

All Rights Reserved. Copyright 2010 J-Power 90

2.2.8 Protection System



Protection system is required to prevent failures of important equipment or spread of accident in the power plant. The protection system varies slightly depending on the method of supervisory control, but four (4) types are normally used as follows.

(a) Emergency Stop (86-1)

This protection is employed when it is necessary to immediately stop the operation after the occurrence of electrical failures such as short-circuit or ground fault at generator.

In this case, circuit breaker (CB) for the generator must be immediately opened and then turbine quickly stopped.

All Rights Reserved, Copyright 2019 J-Power

91

(b) Quick Stop (86-2)

This protection is employed when it is necessary to immediately stop the operation after the occurrence of mechanical failures such as over-heat or bearing melt and governor trouble at generator or turbine.

In this case, the turbine input must be reduced and generator CB opened and turbine stopped.

(c) No-load no-excitation operation

When an electrical fault such as generator over-voltage occurs, the generator CB be opened, but the turbine is continuous running and generator is no-excitation and no-load operation, thus the plant can be connected immediately in to the power system after the fault has been cleared.

All Rights Reserved, Copyright 2019 J-Power

92

(d) Light fault



When a minor accident occurs but the machine is not required the stopping, an alarm is given in order to urge the operator to take necessary measures for preventing the fault expansion.

In the case of small-scale hydropower, fault 86-1, 86-2 and No-load no-excitation operation are, all handled together, categorized as [emergency stop] and [alarm].

2.2.9 Instrumentation System

Instrumentation is provided for supervising and periodically recording the Voltage (V), Current (A), frequency (Hz), out put (kW), etc. and temperatures of generator winding in order to determine the operation conditions. Instruments are normally of meters, record indication lamps for visual and writing method.

All Rights Reserved, Copyright 2019 J-Power

93

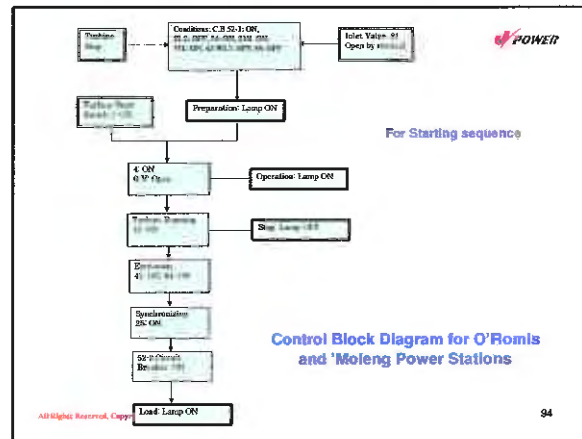

All Rights Reserved, Copyright 2019 J-Power

94

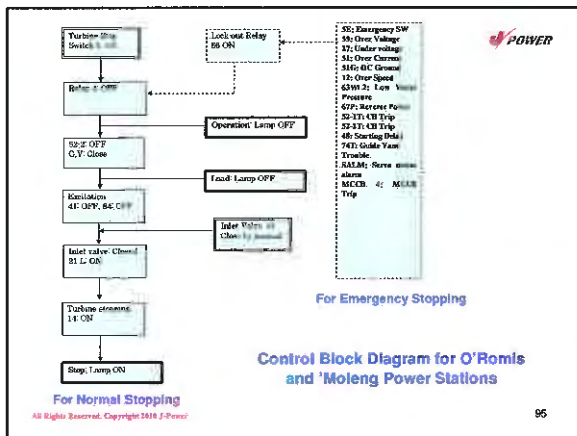

All Rights Reserved, Copyright 2019 J-Power

95

3. Diesel Generator Power Station (300kW) in Mondul Kiri Power System



DG station is having a function for black start of the power system



All Rights Reserved, Copyright 2019 J-Power

96

4. Transmission Line Facility



- 1) 400V/22kV Step-up Transformer (250kVA)
- 2) 22kV/400V Substation



Step up Tr. at P.S (400V/22kV)



Step down Tr. at Substation (22kV/400V)

All Rights Reserved, Copyright 2019 J-Power

97

- 1) 400/220V Distribution line: 33 km
- 2) 22kV Transmission line :28 km



insulators



22kV Transmission Lines

All Rights Reserved, Copyright 2019 J-Power

98

4.1 Disconnecting Switch



1) Disconnecting switch

The switch does not have ability of switching the load current. The switches are used for open or connect between the line and generator main circuit or using for maintenance of the circuit breaker, transformer and generator.

2) Cut-out Switch

Cut-out switch have a power fuse function, the fuses is apply for greater than 1,000 V and called for power fuse: 24kV, 16A, 12.5kA.

3) Air load breaking switch

The switch is used in the high voltage AC lines for switching the lines. The load current can be switched but can not be switched short-circuit current in the lines. 24kV, 600A, 12.5kA outdoor

All Rights Reserved, Copyright 2019 J-Power

99

4.2 Transmission Method



- 1) The three (3) phases - three (3) wires transmission system is a most advantageous followed by the single phase transmission line.
- 2) The three (3) phases - four (4) wires system is frequently utilized for distribution lines.

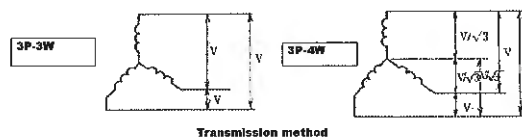

Transmission method

All Rights Reserved, Copyright 2019 J-Power

100

4.3 Reactive Power



- > The transmission lines must be kept the system voltage within $22kV \pm 8\%$ at sending and receiving terminal in target. The reactive power is controlled by the power stations as required for adjusting the voltage of receiving points at the substation.
- > If large lagging current flows through the transmission line as a results of the operation of lagging loads like induction motors, etc, resulting in a voltage drop.
- > Long distance transmission lines are greatly affected by the charging current of the line during light load, so as to make the voltage at receiving points higher than the voltage at the sending points.
- > The reactive power can be controlled by generator operation with adjustment exciter current as a power factor from sending terminal.

All Rights Reserved, Copyright 2019 J-Power

101

4.4 Lightning Prevention



To cope with external abnormal voltages due to lightning or surging phenomena in the power system, it is necessary to provide countermeasure against the abnormal voltage within the predetermined value for preventing the occurrence of accident.

Actual measures to be taken are,

- To direct the lightning strike by means of an overhead ground wire (OGW),
- To pass the current due to lightning strike safely through steel towers and tower-footing resistance to the earth,
- To limit the abnormal voltage by means of lightning arrestors or surge absorbers.

All Rights Reserved, Copyright 2019 J-Power

102

4.5 Grounding at Power Station



Grounding at power stations are provided with earth electrodes and earthen wire mesh for reducing the ground resistances according to the design values.

For preventing a tower from back-flashover due to lightning stroke in the power station and for protecting personals, beast and low voltage equipment during accidents in the power system.

All equipment in the power station must be connected with grounding system.

All Rights Reserved, Copyright 2010 J-Power

103

4.6 Distribution Facility



Distribution means the allocation and supply of power, and the portion located downstream of the distribution substation as called distribution system.

1) Distribution Network

The distribution network is classified 1) Tree-, 2) Loop-, 3) Mesh- and 4) Junction connection in the distribution lines.

2) Distribution Voltage

Various countries are different operating voltage depending on the owned power system. Cambodia standards has provided with 400V/ 230V for distribution system for consumers.

All Rights Reserved, Copyright 2010 J-Power

104

3) Distribution Line Materials



1) Electric wire

Hard drawn copper wires, PVC insulated wires and All Aluminum Conductor (AAC) and All Aluminum Alloy Conductor (AAAC)

2) Supports

Wooden poles, concrete poles or panzer masts are used as electric poles. Wooded arms or metal fittings are attached to the poles for supporting wires or racks are installed for vertical arrangement.

3) Distribution transformers

Distribution transformers are normally installed on electric poles and providing 5 to 30kVA of single, but three phases transformers are installed large capacity such as 30 to 100kVA.

4) Insulators

There are kind of insulators such as a) Pin type, b) Tension type and c) Suspension type.

All Rights Reserved, Copyright 2010 J-Power

105

4.7 Neutral Grounding Method



The following methods can be applied as grounding system.

- 1) Un-grounding system (Floating system)
- 2) Solidly grounding system
- 3) Resistance grounding system
- 4) Reactor grounding system

This should be determined in relation to the each design of the power system.

All Rights Reserved, Copyright 2010 J-Power

106



Thank you for your attention
J-Power Group, Japan

All Rights Reserved, Copyright 2010 J-Power

107

**Project for Operation and Maintenance of the
Rural Electrification on Micro-hydropower
in Mondul Kiri, Cambodia**

**3. Mondul kiri Electrification
Project (Construction)**

*By JICA Study Team
/Electric Power Development Co., Ltd. (J-POWER)
/The Chugoku Electric Power Co., Ltd. (ENERGIA)*

Mondul Kiri Electrification Project, MIME/DIME
 under the Project Aid, JICA Japan in 2008
 Consultant: J-Power, Japan



All Rights Reserved, Copyright 2010 J-Power

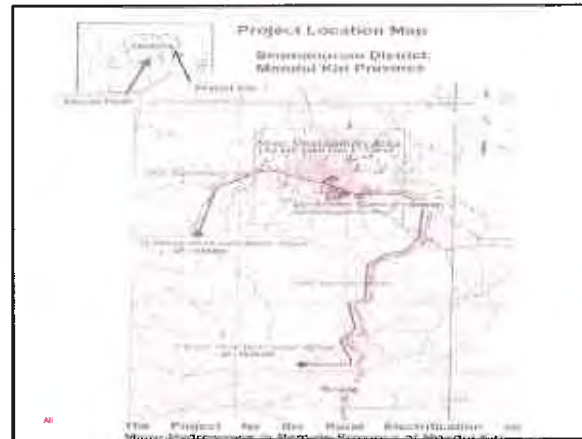

5. CONSTRUCTION SCHEDULES

THE SCHEDULE FOR THE WORKS IMPLEMENTATION IN EARLY PERIODS IN EARLY PERIODS OF WORKS

Work Item	Start	End	Duration	Remarks
1. Site Preparation	1/10	1/15	5	
2. Access Road	1/15	1/25	10	
3. Intake Weir	1/25	2/10	15	
4. Sedimentation Basin	2/10	2/25	15	
5. Penstock	2/25	3/10	15	
6. Spillway	3/10	3/25	15	
7. Powerhouse	3/25	4/10	15	
8. Tailrace	4/10	4/25	15	
9. Final Site Preparation	4/25	5/10	15	

All Rights Reserved, Copyright 2010 J-Power

Main Working Item of The Project

1. Construction Works

(1) O'Moleng Hydropower Station

- a) Access Path Road : Width: 2.8m, Length: 411m
- b) Intake Weir : Height: 5.2m, Length: 60m
- c) Sedimentation Basin : Width: 2-4m, Height: 5-6m, Length: 23m
- d) Penstock : Length: 415m, Diameter: 1.2-0.7m

All Rights Reserved, Copyright 2010 J-Power

(2) O'Romis Hydropower Station

- a) Access Path Road : Width: 2.8m, Length: 1,085m
- b) Intake Weir : Height: 4.3m, Length: 41m
- c) Sedimentation Basin : Width: 2-4m, Height: 5-6m, Length: 23m
- d) Waterway : Length: 1,015m, Canal: 1.0m width
- e) Head Tank : Width: 1-4m, Length: 20m, Height: 1.6-5.0m
- f) Spillway
- g) Penstock : Length: 63m, Diameter: 0.8-0.6m
- h) Powerhouse : One-Story, 56m²

All Rights Reserved, Copyright 2010 J-Power

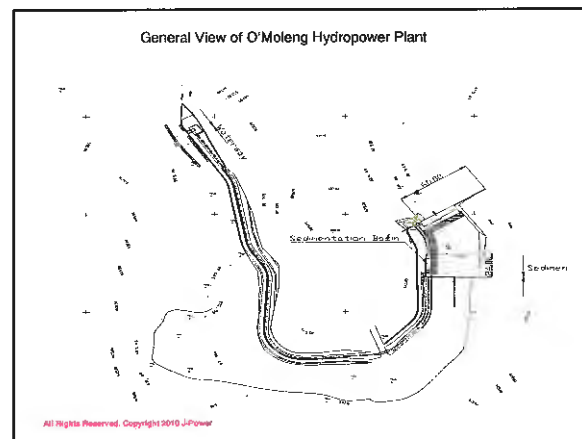



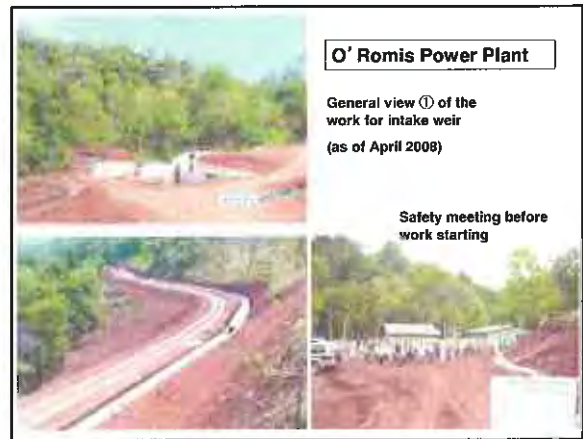
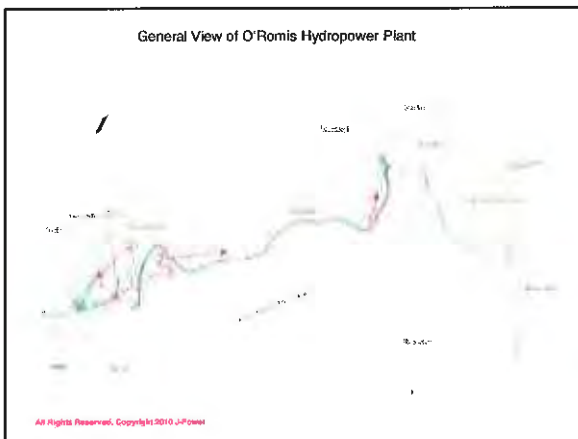
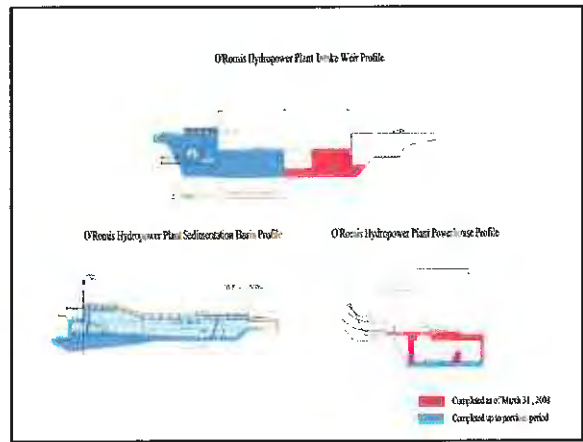
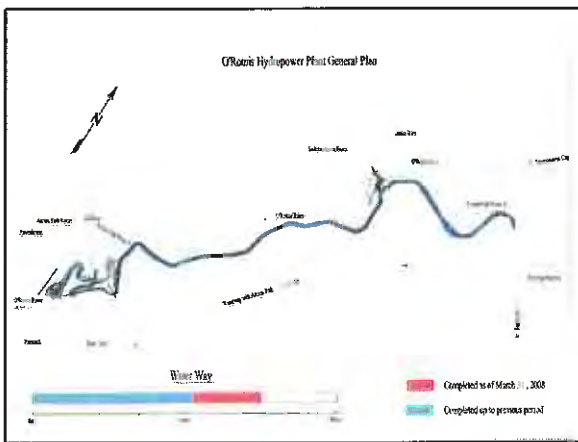
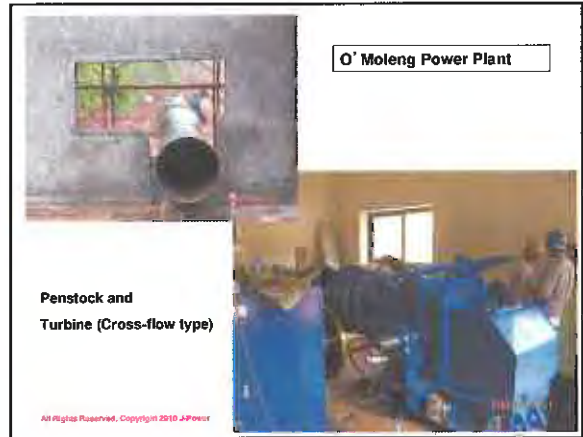

O' Romis Power Plant



General view ③ of the work for water way, head tank, penstock and spill way



General view ④ of the work for powerhouse and steal penstock

All Rights Reserved. Copyright 2010 J-Power

O' Romis Power Plant



State of re-bar and form work for water way



State of re-bar and form work for the base of powerhouse

All Rights Reserved. Copyright 2010 J-Power

O' Romis Power Plant



State of earth work for access path



Monthly safety meeting on March at O' Romis site

All Rights Reserved. Copyright 2010 J-Power

O' Romis Power Plant



Intake Dam



O' Romis Power Plant



General view ① of the work for intake weir (As of 28 May 2008)



General view ② of the work for water way & access path (as of 28 May 2008)

All Rights Reserved. Copyright 2010 J-Power

Waterway and Head Tank for O' Romis Power Plant (as of May 2008)





O' Romis Power Plant

Penstock and Powerhouse



**O' Romis Water Turbine 185kW
(Cross-flow type)**

All Rights Reserved, Copyright 2010 J-Power

Administration Office Plan

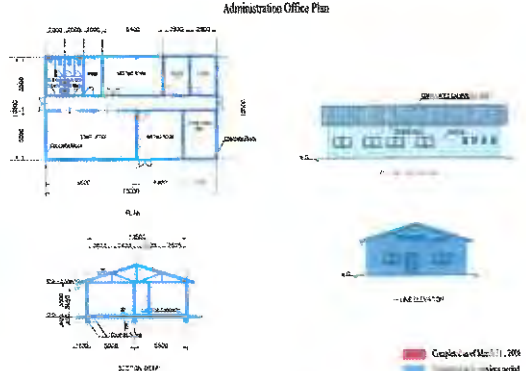

Completed March 2011, 20%
Completed up to preconstruction

General view of the work for administration office and diesel generating powerhouse



State of steel structure work for diesel generation powerhouse



State of plaster work for diesel generation powerhouse



Diesel Power Plant (left) and Administration Office (below)



All Rights Reserved, Copyright 2010 J-Power

Diesel Generating House Plan

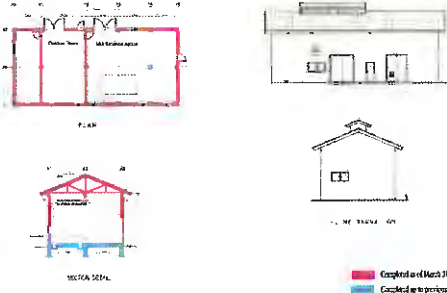

Completed as of March 21, 2011
Completed up to preconstruction

Diesel Power Plant



**Fuel Oil Storage Tank
(10,000 liters)**

Completion of O'Moleng Power Station, October 2008



All Rights Reserved, Copyright 2010 J-Power

Completion of O' Romis Power Station, October 2008



All Rights Reserved, Copyright 2010 J-Power

Completion of DG Power Station & Transmission Line, October 2008



All Rights Reserved, Copyright 2010 J-Power

O&M Data : Energy Production during 2008-2009

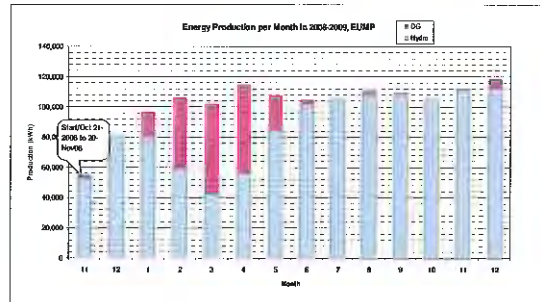

All Rights Reserved, Copyright 2010 J-Power

O&M Data : Energy Production in 2010

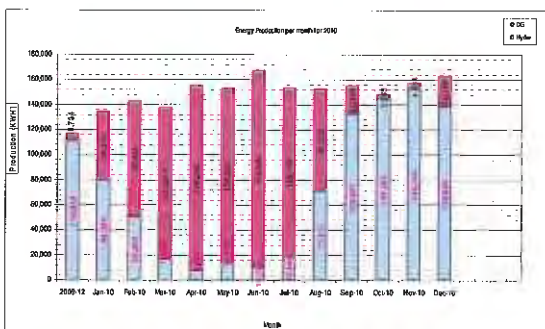

All Rights Reserved, Copyright 2010 J-Power

Energy production & Total Running Hours during 2008-2009

	kWh			Total Running Hours		
	Hydro	DG	Load	O'Moleng	O' Romis	D/G
2008/11	80,221	0	80,221	895	895.5	67.19
12	80,221	0	80,221	706	706	67.19
2009/1	80,694	15,908	96,602	715	744	140.2
2	59,494	46,484	105,978	453	731	365
3	42,787	59,195	101,982	288	631.8	495.5
4	58,572	58,341	116,913	291	780.3	480.2
5	84,770	22,898	107,668	610	710.3	160.3
6	102,185	3,033	105,218	822	681.6	41.9
7	105,240	0	105,240	888	780	0
8	108,258	1,981	109,817	705	512.3	26.8
9	108,458	587	109,045	713	712.9	3.3
10	105,229	0	105,229	693.4	692.7	0.5
11	111,898	57	111,915	698	692.2	3.6
12	112,898	5,929	118,437	679.5	687.8	83.3
Total	1,211,535	214,630	1,428,165	8454.9	9886.3	1785.89

All Rights Reserved, Copyright 2010 J-Power

Energy Production & Total Running Hours in 2010

	kWh			Energy Sold in kWh	Total Running Hours		
	Hydro	DG	Load		O/Moleng	O/Romis	D/G
2009-10	110,810	6,345	110,244	108,224	709	711.8	58
Jan-10	80,094	54,510	134,344	131,000	482	741	124.3
Feb-10	50,585	52,427	142,865	140,418	217.8	738.9	587.4
Mar-10	16,822	121,319	138,141	138,222	177.8	284.1	643
Apr-10	7,230	148,283	155,513	155,428	132.9	27.2	738.7
May-10	14,153	139,035	153,188	153,119	214.7	72.5	707
Jun-10	10,128	158,504	167,800	167,116	180.7	15.1	720
Jul-10	18,504	135,138	153,720	153,008	169	155.5	708.7
Aug-10	71,277	81,332	152,609	151,384	474.4	587.2	485.5
Sep-10	132,867	22,354	155,351	155,323	685.2	744.1	177.5
Oct-10	145,392	2,885	148,187	148,081	719.0	720.8	58.8
Nov-10	152,742	4,884	151,587	151,267	739	739.5	58.1
Dec-10	158,063	24,750	162,841	162,841	894.9	719.8	194.0
Total	811,888	541,827	1,351,344	1,350,284	4,894.31	6,517.18	1,217.18

All Rights Reserved. Copyright 2010 J-Power

O&M Data : Daily Load Curve (Jan. 2010)

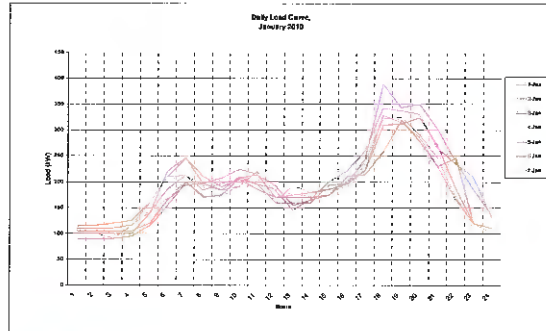

All Rights Reserved. Copyright 2010 J-Power

O&M Data : Daily Load Curve (Nov. 2010)

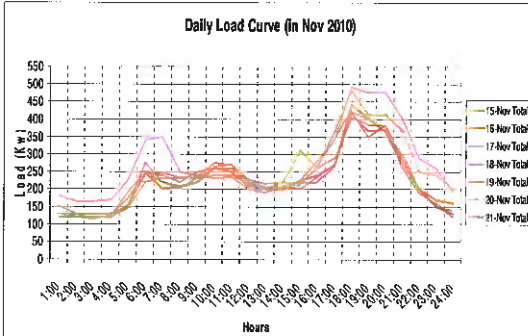

All Rights Reserved. Copyright 2010 J-Power

O&M Data : Number of Customers during 2008-2010

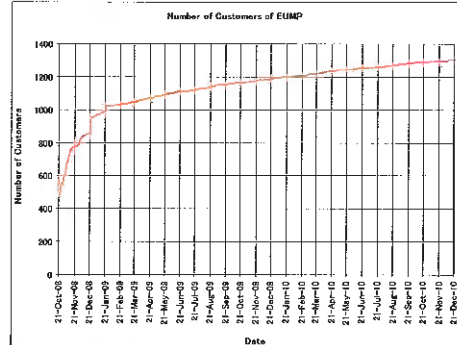

All Rights Reserved. Copyright 2010 J-Power

O&M Data : Daily Energy Consumption during 2008-2010

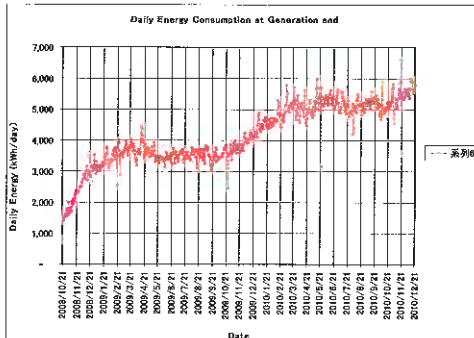

All Rights Reserved. Copyright 2010 J-Power

O&M Data : Maximum Daily Demand during 2008-2010

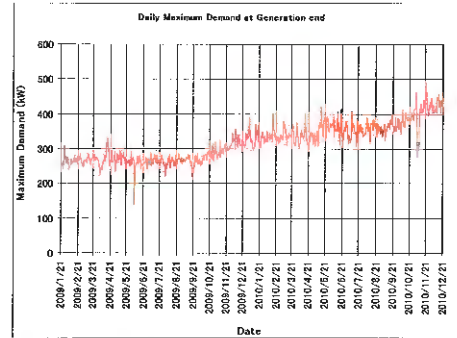

All Rights Reserved. Copyright 2010 J-Power

O&M Data : System Losses during 2008-2010

At the first month of commercial operation, the Energy losses is approximately 32% high. But the losses is decreasing gradually in the following months, even if energy consumption is being increased.

Total Losses In Power System

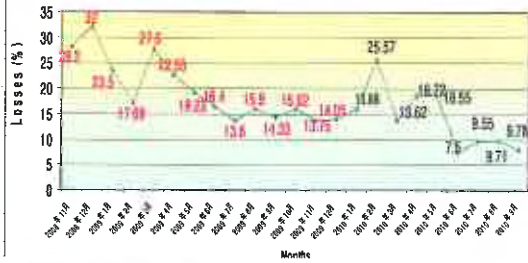

All Rights Reserved, Copyright 2010 J-Power



Thank you for your attention,

J-Power Group, Japan

All Rights Reserved, Copyright 2010 J-Power

Appendix 4-10

一般防災業務計画

(2011年2月)

目次

第1章 防災体制の確立

第1節 防災体制

第2節 対策組織の運営

第3節 社外機関との協調

第2章 災害予防に関する事項

第1節 防災教育

第2節 防災訓練

第3節 電力設備の災害予防措置に関する事項

一般防災業務計画

第1章 防災体制の確立

第1節 防災体制

1. 防災態勢の区分

災害が発生するおそれがある場合、または災害が発生した場合に対処するための態勢は次の区分による。

災害が発生するおそれがある場合、または災害が発生した場合に対処するための態勢は次の区分による。防災が発生した場合は下記区分により防災本（支）部を設置するものとする。

表-1 防災体制区分：Disaster Management Support System (DMSS)

情勢	態勢の区分
1. 連絡態勢	災害が発生するおそれがある場合で、警戒態勢を発令する必要が無いと認められた場合
2. 警戒態勢	災害が発生するおそれがある場合
3. 非常態勢	災害が発生した場合 警戒宣言が発せられた場合

2.

防災本部および支部の警戒態勢および非常態勢に対応する対策組織および分掌事項は別表-1および2のとおりとする。なお、1. 連絡態勢については、防災本部を設置しないものとする。

また、災害により各機関が被災した場合の、非常災害対策活動の拠点をあらかじめ定めておくものとする。

第2節 対策組織の運営

1. 防災態勢の発令および解除

- (1) 態勢の発令者は、次によるものとする。解除の場合も同様とする。
- (2) 警戒態勢および非常態勢が発令された場合は、速やかに本（支）部を設置する。
- (3) 発令した態勢は、その必要が無くなった時は、これを解除する。
- (4) 態勢の発令（解除）者の代行者は、あらかじめ定めておく。

2. 権限の行使

- (1) 警戒態勢および非常態勢が発令された場合、災害対策活動に関する一切の事務は、防災本（支）部のもで行う。
- (2) 警戒態勢および非常態勢が発令された場合、本（支）部長は、職制上の権限を行使して活発に対策活動を行う。ただし、権限外の事項であっても緊急に実施する必要のあるものについては、臨機の措置を行うことができる。
なお、権限外の事項については、行使後速やかに所定の手続きをとる。

3. 動員

本（支）部長は、発令後直ちにあらかじめ定める対策要員の動員を指示する。

4. 指令伝達および情報連絡の経路（緊急連絡態勢：CEPRC）

本（支）部が設置された場合の指令伝達および情報連絡の経路は、図-1 のとおりとする。

Fig-1 CENTER OF EMERGENCY PREPAREDNESS AND RESPONSE COMMUNICATIONS (CEPRC) at Mondulkiri

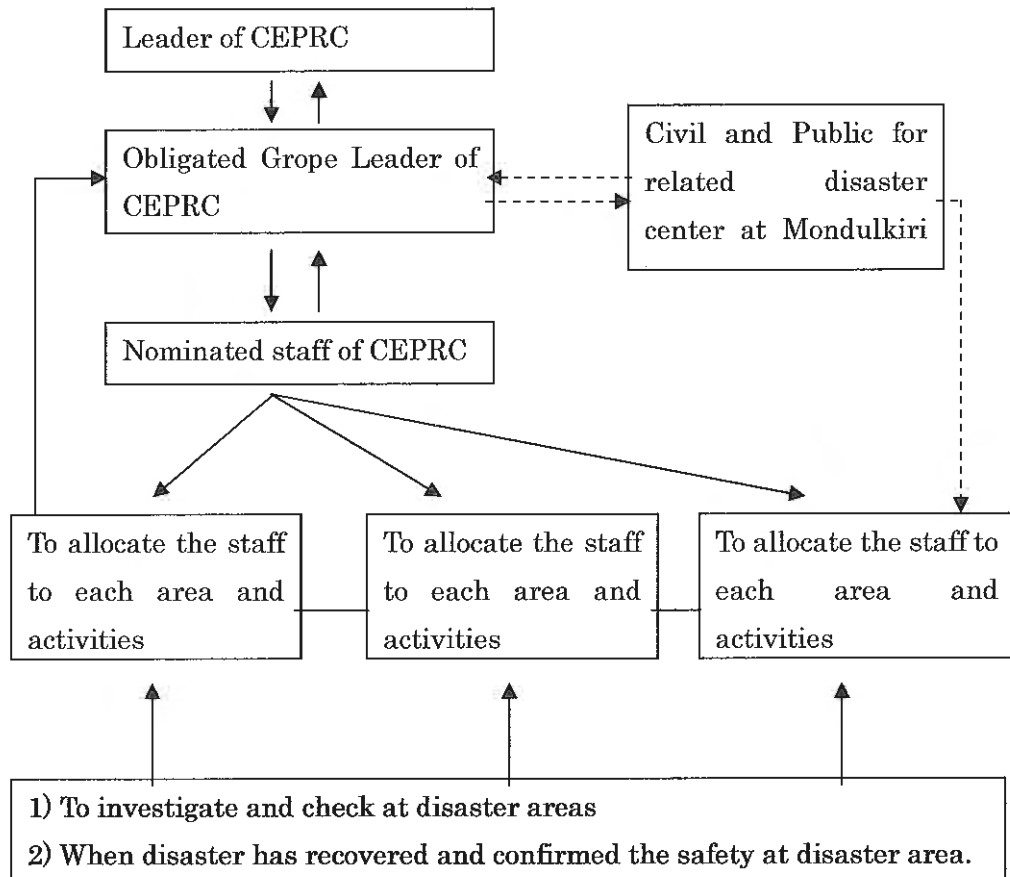

第3節 社外機関との協調

1. 地方防災会議等

平常時には、各機関が当該地方公共団体の防災会議等と、また災害時には、各本（支）部が当該地方公共団体の災害対策本部等と緊密な連携を保ち、この計画が円滑・適切に行われるように努める。

2. 防災関係機関との協調

地方気象台、消防署等防災関係機関とは平常時から協調し、防災情報の提供、収集等相互連携体制を整備しておく。

防災関係機関との対応は、表-2のとおりとする。

3. 他関係会社等との協調

EDC 本部、関係会社、請負会社および隣接企業等と協調し、電力、要員、資材、輸送力の相互融通等、災害時における相互応援体制を整備しておく。

第2章 災害予防に関する事項

第1節 防災教育

各機関においては、従業員に対し、災害に関する専門知識の普及、関係法令集、関係パンフレット等の配布、検討会の開催、社内報への関連記事掲載等、防災意識の高揚に努める。

第2節 防災訓練

各機関は、災害対策を円滑に推進するため年1回以上防災訓練を実施し、災害時にこの計画が有効に機能することを確認する。

また、国および地方公共団体等が実施する防災訓練には積極的に参加する。

第3節 電力設備の災害予防措置に関する事項

1. 水害対策

(1) 水力発電設備

過去に発生した災害および被害の実情、河床上昇等を加味した水位予想に各事業所の特異性を考慮し、必要に応じ、防水壁の設置、排水ポンプの設置、機器のかさあげ、ダム

通信確保のための設備の設置および建物の密閉化（ケーブルダクトの閉鎖等）等を実施する。

特に、洪水に対する被害防止に重点をおき、次の箇所について点検・整備を実施する。

- ダム、取水口の諸設備および調整池、貯水池の上・下流護岸
- 導水路と溪流との交差点およびその周辺地形との関係
- 護岸、水制工、山留壁
- 水位計

(2) 送電設備

- 架空電線路

土砂崩れ、洗掘などが起こるおそれのある箇所のルート変更、擁壁、石積み強化等を実施する。

- 地中電線路

ケーブルヘッドの位置の適正化等による防水対策を実施する。

(3) 変電設備

浸冠水のおそれのある箇所は、床面のかさあげ、防水扉の取付け、ケーブルダクト密閉化等を行う。

2. 風害対策

各設備とも技術基準等による風害対策を十分考慮するとともに、既設設備の弱体箇所は補強等により対処する。

3. 雷害対策

(1) 送電設備

架空地線の設置、防絡装置の取付け、接地抵抗の低減などを行う。

また、気象通報等により豪雨・雷害を予知した場合は、各担当発電所間で通信系統を確認し、安全確保または拡大防止に努める。

(2) 変電設備

避雷器を設置を確認あるいは増設を考慮し、設備強化に努める。

4. 地盤沈下対策

地盤沈下および地すべり対象地区は、将来沈下が予想される地域のパトロールや安全対策を確保する。もし、事故発生の場合はこれを速やかに修復することに努める。

5. 火災・爆発・油流出等の対策

火災・爆発・油流出等の対象地区は、将来事故が発生する場合も考慮して、地域のパト

ロールや安全対策を確保する。もし、事故発生の場合はこれを速やかに修復することに努める。

6. 地震対策

地震等の対象地区は、将来事故が発生する場合も考慮して、地域のパトロールや安全対策を確保する。もし、事故発生の場合はこれを速やかに修復することに努める。

第4節 災害対策用資機材等の確保および整備

1. 災害対策用資機材等の確保

各機関は災害に備え、平常時から復旧用資材、工具、消耗品等の確保に努める。それらの資材量などは定期的に点検を実施すること。

2. 災害対策用資機材等の輸送

各機関は上記1. の資材搬送確保のための車両等の輸送力確保に努める。

表-2 警戒態勢分掌体系

Electricity of Mondul Kiri Branch, EDC

グループ	グループ責任者	分掌事項	項目
情報統括 G	庶務担当グループ リーダー	(7) 社内外に対する連絡、報告 (8) 対外広報・関係支店・所との連絡 (9) 応急対策用資機材等の確保 (10) 緊急輸送手段の確保 (11) 食糧、被服、医薬品、宿舍等の確保 (12) 周辺地域災害への対応	(13) 情報連絡班における全ての記録および各班の記録の統括 (14) その他の他の各班に属さない事項
発電 G	電気担当グループ リーダー	(1) 電気担当グループが保守・運用を行う設備または工事の施行管理を行う設備に関する、 ① 応急対策実施状況の検討 ② 応急対策実施に伴う指導、助言、応援事項の決定 ③ 請負業者、メーカーとの連絡事項の決定	(2) 防災用通信回線 VHF 確保措置の実施 (3) 周辺地域災害への要員確保 (4) 電気班における全ての記録
土木 G	土木担当グループ リーダー	(1) 土木担当グループが保守・運用を行う設備または工事の施行管理を行う設備に関する、 (2) 周辺地域災害への要員確保 (3) 周辺地域災害への要員確保 (4) 土木班における全ての記録	「電気班」①～③に同じ事項
送電 G	送電担当グループ リーダー	(1) 送電担当グループが保守・運用を行う設備または工事の施行管理を行う設備に関する、 (2) 周辺地域災害への要員確保 (3) 周辺地域災害への要員確保 (4) 送電班における全ての記録	「電気班」①～③に同じ事項
支援 G	会計・業務グループ リーダー	(1) 全てのグループへの支援 (2) 食糧、被服、医薬品、宿舍等の確保 (3) 緊急輸送手段の確保 (4) 緊急資材の購入 (5) その他	
カイセマ地区 G (Key Siema)	カイセマ地区グループ リーダー	(1) 情報統括グループへの支援 (2) 送電グループへの支援	

総括責任者 (CEPRC)

所長 EOM
所長代理 EOM

Meeting Memo (No.1)

For Interconnection from Viet Nam Power System

Date: June 11, 2010 15:00-16:00

Place: EDC meeting room

Attendants: EDC, EUMP and JICA study team, as attached list

Summary of meeting:

1. We have the first meeting for plan of interconnection on the transmission line from Viet Nam.

- 1) EDC has surveyed route of interconnection lines one month before (May 2010), and also confirmed the border of Viet Nam. This survey is a starting of our plan.
- 2) The plan of interconnection line is to be 22kV.
- 3) The transferring capacity is to be limited 3,000kW

2. EDC has also surveyed distribution route on June 3 to 7, 2010 at site.

- 1) EDC has a plan to use a conductor: a) ACSR 150 sq.mm, b) Insulated cable 150 sq.mm, and c) ABC cable 150sq.mm.
- 2) AVR compensator for voltage regulation will be installed at the end terminal of interconnection line
- 3) Both line of Dak Dam and Nam Lea (Busra) have been surveyed but Keov Seima line is not yet. There is possibility Dak Dam line after discussion of EDC and V.N, even if transmission line of V.N side will be longer than Cambodia side.

3. EDC is a lucky chance to import the power from V.N because of reducing the tariff in the future.

4. JICA study team has explained reasons why to have a meeting as attached paper and request the technical study on 21 June 2010 at 10:00 at EDC head office.

EDC confirmed to have a meeting on 21 June 2010.

5. EDC strongly requested JICA study team to join the technical meeting later on. EDC will explain next meeting more detail information for the interconnection plan.

--- Ended-----

Attached : 1) Attendants list

2) Information from JICA study team

Route of Interconnection between EUMP Power System and 22kV V.N System

2010/06/11

1. The comparison of 22kV T/L routes between EUMP and V.N

	Description	Route A (Keov-Seima)	Route B (Dak Dam)	Route C (Busra)
1	Route length from border	Approx. 70km	Approx. 30km	Approx. 70km
2	Road condition	Pavement	Dirt	Dirt and no road in some area.
3	Environmental condition	Passing forest and required cutting trees some area	No forest and no required cutting trees	Passing forest and required cutting trees so many
4	Waiting consumers	Approx. 50-100 households	same	same
5	T/L condition in V.N side	There is existing 22 kV line from 18km of border, To s/s approx. ? km	To s/s approx. 80km and required to change conductor (55mm ² to ?)	To s/s approx. 45km

2. Technical point

1) Change of the conductor

Modul Kiri: AAAC55 sqmm

V.N: 150 sqmm

2) Different of Transmission line system

Mondul Kiri: 3 Phases 3 wires- floating system (Non grounding system)

V.N: 3 Phases 4 wires- Resistance grounding system

3) Voltage drop

Meeting Memo (No.2)
For Interconnection from Viet Nam Power System

Date: June 21, 2010 10:00-12:00

Place: EDC meeting room

Attendants: EDC, EUMP, JICA Volunteer Expert and JICA study team

Summary of meeting:

1. The 2nd meeting of Interconnection of V.N is a discussion of technical matter and showing EDC' plan.

2. EDC explained 2 items that,
 - 1) Connection point of the 22kV transmission line (T/L) in Mondul Kiri power system,
EDC explained that 22kV T/L will be set with double lay on the existing concrete pole from No. PMT-01 (near O'Romis P.S) up to Hospital or District Cubicle stations. This connection cubicle (end terminal) will be fixed after site survey at site.
EDC will design and provide the necessary equipment such as LBS, Metering, AVR (auto transformer) Capacity bank, and synchronizing equipment, etc.

 - 2) Plan of synchronizing between V.N and Mondul Kiri system.
EDC asked JICA study team to suggest the Specifications and cost estimation of synchronizing equipment, JICA study team will advise it.

3. The Specifications and cost estimation will be provided within this year and make bidding, if possible.

4. Next meeting will be held in July with Mr. Shinohara (T/L advisor) and August with Mr. Hiraga.

---- Ended-----

Attached : 1) Connection plan drawing

Meeting Memo (No.3)

For Interconnection from Viet Nam Power System

Date: August 12, 2010 9:00-11:00

Place: EDC meeting room

Attendants: EDC Mr. Houng Chantha (technical office), Generation Dept.

EM Mr. Khinand, JICA study team (Mr. Hiraga)

Summary of meeting:

1. EDC has surveyed the route of interconnection lines and decided the interconnection point at inside of O'Romis power station or near national road area.
EDC will finalize the place after internal discussuin.
2. As for the save of budget, the conductor is to be changed 22kV AAAC 95mm² from 150mm².
3. The construction of 22kV line will be started around early next year, 2011 after bidding finished.
4. JICA study team has recommended taking consideration of safety measure and maintenance condition to be placed the interconnection point.
5. JICA study team has also recommended that CB (circuit breaker) panel is provided in the design due to the technical point of view.
6. EDC requested that JICA study team will advise the design of CB panel with budget breakdown by the next visiting.
7. After getting the advise from CB panel design, EDC will make a proposal of budget and design plan and finalization of the interconnection plan.

--- Ended ---

Fig-3.2 Single Line Diagram for 22kV Interconnection Cubicle (Between Mondul Kiri and Viet Nam Power System)

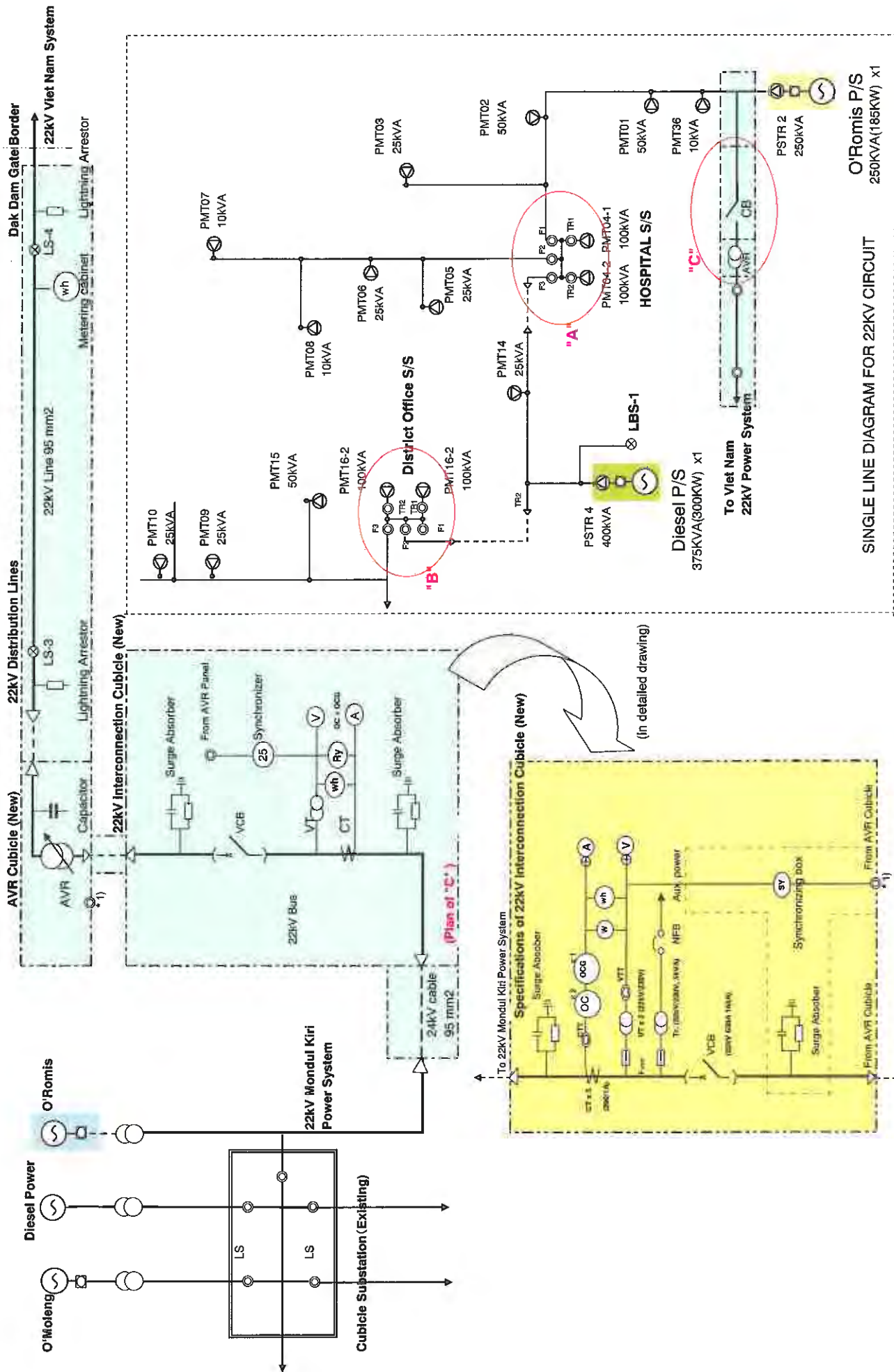

(Scope of Work for 22kV Interconnection Cubicle)

**TECHNICAL SPECIFICATIONS
FOR
INTERCONNECTION OF 22KV POWER SYSTEM
IN MONDUL KIRI, EDC
(Between Mondul Kiri and Viet Nam)**

September 2010

Recommended by JICA Study Team

**TECHNICAL SPECIFICATIONS
TABLE OF CONTENTS**

Section 1	General.....	2
1.1	Scope of Works.....	2
1.2	General Requirement for Works.....	2
1.3	Tests on Completion.....	2
Section 2	Interconnection Equipment.....	3
2.1	Scope of 22kV Interconnection Equipment	3
2.2	22kV Interconnection Panel (VCB Panel)	3
2.2.1	Enclosure.....	4
2.2.2	Busbars and Connections	5
2.3	22kV Vacuumed Circuit Breaker (VCB).....	5
2.4	Surge Absorbers.....	7
2.5	Current Transformers.....	7
2.6	Voltage Transformers.....	8
2.7	Control and Protection for 22 kV Power System	9
2.8	Miscellaneous Materials	9
2.8.1	Scope of Miscellaneous Materials	9
2.8.2	Power Cables	10
2.8.3	Control Cables.....	10
2.8.4	Insulated Wires	10
2.8.5	Bare Copper Conductor	10
2.8.6	Earthing Rod	10
2.8.7	Other Materials	10
Section 3	Drawings	11
3.1	Single Line Diagram for 22kV Power System of Mondul Kiri, EDC.....	11
3.2	Single Line Diagram for Interconnection Cubicle	11

TECHNICAL SPECIFICATIONS

Section 1 General

1.1 Scope of Works

The Contractor shall be responsible for the designing, manufacturing, supplying, testing before shipment, finishing, painting, packing for transport, insuring, shipping, delivering to the Port, landing, customs clearing, transporting to the Site, erecting, training, Site testing and commissioning of the Scope of Works.

1.2 General Requirement for Works

(1) Contractor's Temporary Facilities

The Client will provide the Contractor, free of charge, with stock yard in temporary for construction materials at the Site. After completion of the Works, the Contractor shall, at his own cost and expenses, clean and repair restore the stock yard into the original condition.

(2) Minimum Requirement

(a) The Contractor shall submit the Implementation schedule.

(b) The Contractor shall be responsible for making every necessary arrangement to secure the safety during the Construction at site.

(c) In case of the repair in finishing works for concrete foundation put on the panels shall be undertaken only by the Contractor at his own expense and shall be subject to inspect by the Client.

(d) The Contractor shall, at his own expense, do all excavation, backfilling and restoration for the purposes of repairing into original conditions or other defect as discovered during the period of the test.

(e) The work under this section shall comprise the supply of fence to be protected from any miscellaneous objective in the setting area for electrical equipment.

(f) The installation work shall include storage, transport to the work spot, installation, erection, site tests shall be executed in accordance with the "For Work Drawings" and the approved installation procedures by the Client.

(g) The shop test for Interconnection cubicle including circuit breaker (VCB) shall be conducted under the presence of Client.

(h) The Contractor shall submit Client the technical drawing and documents for approval and also submit a required necessary data for reference

The drawing/document/Instruction manual shall be submitted each 5 sets for Approval, for Final and for As-built-drawing. 2 sets of completed PDF file in CD-R for As-built-drawing shall also be submitted to Client.

1.3 Tests on Completion

After completion of the entire project works, the site test shall be done prior to the charging test of the 22kV lines in close cooperation with the Client.

Section 2 Interconnection Equipment

2.1 Scope of 22kV Interconnection Equipment

The Contractor shall supply and commission the following equipment:

- (1) 22kV Interconnection Panel (VCB Panel)
- (2) 22kV Vacuum Circuit Breaker (VCB)
- (3) 22kV Surge Absorber (SA)
- (4) Control and Protection equipment
- (5) General electrical works
- (6) Spare parts

2.2 22kV Interconnection Panel (VCB Panel)

The cubicle shall be consisted the following equipment and parts.

One (1) set of 22kV outdoor Kiosk with metal-clad type switchgear assembly mounted inside the following equipment:

- (1) One (1) set of three-pole 22kV Vacuum type circuit breaker (VCB) for main circuit
- (2) Two (2) sets of 2-poles 230 V MCCB for auxiliary power supply circuit with shunt trip mechanism (one for spare)
- (3) One (1) set of three phases busbar
- (4) One (1) watt meter 0-3,000 kW for main circuit
- (5) One (1) A.C. voltmeters 0-25 kV with change over switch
- (6) One (1) A.C. ammeters 0-300 A with change over switch
- (7) One (1) frequency meter 45-50-55 Hz
- (8) One (1) watt-hour meters
- (9) One (1) set of group fault indicators
- (10) One (1) set of status indication lamps
- (11) Two (2) over current relays (51)
- (12) One (1) over current ground relays (51G)
- (13) One (1) overvoltage relay (59)
- (14) One (1) reverse-power relay (67)
- (15) One (1) lot of VT, CT of auxiliary transformers for the control and protection
- (16) One (1) lot of indication lamps as required
- (17) One (1) synchronizing equipment with control relay (automatic – manual change)
- (18) One (1) lot of alarming devices; buzzer, bell and their control bottoms
- (19) Six (6) sets of surge absorber
- (20) One (1) Voltage indicator (LED) for charging

- (21) Six (6) sets of Cable terminal for Income and outgoing
- (22) Terminal blocks and other necessary accessories to make a complete working excitation control system

2.2.1 Enclosure

(1) Type

22kV switchgear shall be of floor-standing, outdoor installation, metal-clad type conforming to IEC 298 (1981) and of robust construction.

The degree of protection for the enclosures and partitions, conforming to IEC 694 & 298, shall be as follows:

- (a) Enclosures: IP 2X or equivalent
- (b) Partitions: In Compartment

(2) Construction requirement

The enclosures for the switchgear shall be constructed by rigid framed, floor-standing structure completely enclosed by sheet steel.

The withdrawable type equipment compartment shall be provided with a shutter to prevent exposure of stationary live contacts when the equipment is in the disconnected, test or removed position.

The enclosure shall be provided with access doors to facilitate inspection of the equipment, provided with suitable handles with locks.

The enclosure shall be provided with suitable cable terminal compartments for the following 22 kV cross-linked polyethylene (XLPE) insulated power cables: Suitable means shall be provided for supporting the terminal and cables.

- (a) One (1) circuit of 95 mm² or more, three-core type, for 22kV income circuit from 22kV Viet Nam power system under this Contract,
- (b) One (1) circuit of 95 mm² or more, three-core type, for 22kV outgoing circuit to existing 22kV power system line.

A copper ground busbar of 3 x 20 mm² or a similar size shall be provided at the bottom of the enclosure. Clamp type grounding terminals shall be provided for connecting the grounding system.

(3) Accessories

The following items shall be provided for the enclosures:

- (a) Name plates for the equipment to be housed
- (b) Channel bases
- (c) Foundation bolts and nuts
- (d) Grounding pads
- (e) Other necessary accessories

2.2.2 Busbars and Connections

(1) Type

The busbars and electrical connections shall be of electrolytic copper or aluminium alloy silver coated, sufficiently insulated from ground and from each other.

(2) Rating

The busbars shall be rated as follows:

- (a) Rated voltage 24 kV
- (b) Rated insulation level 125 kV
- (c) Rated normal current 630 A
- (d) Rated short-time withstand current 16 kA for one (1) second

The busbars shall be designed to carry continuously the rated normal current without exceeding a temperature rise of 50°C at an ambient temperature not exceeding 40°C.

2.3 22kV Vacuumed Circuit Breaker (VCB)

(1) Requirement: One (1) set

The circuit breaker shall be served for 22kV line control and protection according to Standards IEC60056 (or JEC2300).

(2) Type

The circuit breaker shall be of vacuum type, three-pole, single throw, withdraw-able, surge suppressive type, electrically and mechanically trip-free in any position with anti-pumping feature, complete with necessary controls and wiring, draw-out wheels, and any other accessories needed for operation.

(3) Rating

The circuit breakers shall be rated as follows:

- (a) Rated voltage 24 kV
- (b) Rated insulation level 125 kV
- (c) Rated normal current 630 A
- (d) Rated short-circuit breaking current (r.m.s.) 16 kA
- (e) Rated interrupting time 5 cycles
- (f) Rated operating sequence CO- 15 sec.-CO

(4) Operating mechanism

The circuit breakers shall be provided with local electrical controls driven by an AC operated closing and tripping system of capacitor trip power supply device and a local manual operation gear. A molded case circuit breaker shall be provided for the A.C supply circuit.

(5) Accessories

The following items shall be provided for the circuit breakers:

- (a) Rating plate
- (b) Position indicating lamps; red and green
- (c) Auxiliary switches
- (d) Operation counter
- (e) Closing spring condition indicator
- (f) Draw-out unit with handle and guide
- (g) Necessary terminal connections
- (h) Local control box with push buttons of "ON" and "OFF"
- (i) Other necessary accessories
- (j) One (1) set of maintenance tools
- (k) One (1) manual charging handle
- (l) One (1) moving cart

(6) Spare parts

The following spare parts shall be furnished and quoted:

- (a) One (1) closing coil
- (b) One (1) tripping coil
- (c) One (1) spring charging motor (if applicable)
- (d) One (1) bushing of each type
- (e) 500% of actual use of indicating lamps and fuses
- (f) One (1) set of indicating lamp lenses; red and green
- (g) One (1) set of contacts, coils, relays, valves and other small components

(7) Tests

(a) The following test shall be carried out at the manufacturer's plant before shipment, in compliance with IEC 56-4 (1972).

- i) Appearance check
- ii) Power-frequency voltage dry test on the main circuit
- iii) Voltage withstand tests on control and auxiliary circuits
- iv) Measurement of the resistance of the main circuit
- v) Mechanical operating test
- vi) Measurement of making and breaking time

(b) The certificates of the following type test items shall be submitted with the test report:

- i) Mechanical test
- ii) Temperature rise test
- iii) Impulse voltage test
- iv) Short-circuit making and breaking test
- v) Short-time current test

(c) The preliminary and performance tests as specified in Clause GS3.15.19 of Part A General Specifications shall be carried out by the Contractor at the Site.

2.4 Surge Absorbers

The surge absorber shall be consisted of capacitor and lightning arrester. The surge absorbers shall be installed in the 22kV Interconnection Cubicle. The rating of the surge absorber shall be as follows:

- | | | | |
|-----|-------------------------|---|-------|
| (a) | Rated voltage | : | 24 kV |
| (b) | Rated discharge current | : | 10 kA |
| (c) | Rated frequency | : | 50 Hz |

The grounding wire for the surge absorber on one pole can be connected together to one electrode, but the grounding circuit of the surge absorber shall not be connected to the grounding circuit of other equipment.

2.5 Current Transformers

(1) Type

The current transformer shall be of single-phase, epoxy molded type according to Standards IEC60044-1 (JEC1201).

(2) Rating

The current transformers shall be rated as follows:

- | | | |
|-----|---|--------------------------|
| (a) | Highest system voltage | 24 kV |
| (b) | Rated insulation level | 125 kV |
| (c) | Rated current ratio (Rated primary current/Rated secondary current) | 15-100/5 A |
| (d) | Rated burden | as required |
| (e) | Rated short-time thermal current | 16 kA for one (1) second |
| (f) | Accuracy class | |
| | i) for measuring | 1.0 |
| | ii) for protective relaying | 5P20 |

The rated burden of each current transformer shall be proposed by the Contractor to suit the actual burden required for the protective relays, cables and wires. A calculation sheet for the rated output shall be submitted for approval.

The current transformer with other type and ratings for protective relaying may be proposed by the Contractor for approval.

(3) Accessories

The following items shall be provided for the current transformers:

- (a) Rating plates
- (b) Necessary terminal connections
- (c) Other necessary accessories

(4) Tests

- (a) The following tests shall be carried out at the manufacturer's plant:

- i) Appearance check
 - ii) Measurement of current ratio
 - iii) Check of relative polarities
 - iv) Power frequency voltage test on primary winding
- (b) The certificates of the following type test items shall be submitted with the test report:
- i) Short-time current test
 - ii) Temperature rise test
 - iii) Impulse voltage test
 - iv) Test for accuracy

2.6 Voltage Transformers

(1) Type

The voltage transformers shall be of three-phase, epoxy mold type according to Standards IEC60044-2 (JEC1201).

(2) Rating

The voltage transformers shall be rated as follows:

- | | | |
|-----|-------------------------|--------------------|
| (a) | Highest system voltage | 24 kV |
| (b) | Rated primary voltage | 22 kV |
| (c) | Rated secondary voltage | 110 V |
| (d) | Rated burden | As required |
| (e) | Rated voltage factor | 1.2 for continuous |
| (f) | Rated insulation level | 125 kV |
| (g) | Accuracy class | 1.0 |

(3) Accessories

The following items shall be provided for the voltage transformers:

- (a) Rating plates
- (b) Necessary terminal connections
- (c) Fuse for secondary circuit
- (d) Other necessary accessories

(4) Spare parts

The following spare parts shall be furnished and quoted:

- (a) 500% of actual use of fuses

(5) Tests

- (a) The following tests shall be carried out at the manufacturer's plant:
 - i) Appearance check
 - ii) Measurement of voltage ratio
 - iii) Check of relative polarity

- iv) Power frequency voltage test on primary winding
- (b) The certificates of the following type test items shall be submitted with the test report:
 - i) Temperature rise test
 - ii) Impulse voltage test
 - iii) Test for accuracy

2.7 Control and Protection for 22 kV Power System

The following measuring and control instruments shall be furnished and mounted on the front panel or inside of the cubicle. Parts are referred to Clause 2.2.

- (1) Composition for control and protection
 - (a) One (1) auxiliary circuit breaker (NFB) with two positions of "ON" and "OFF"
 - (b) One (1) A.C. voltmeter 0-25 kV with a change-over switch
 - (c) One (1) A.C. ammeter 0-300 A with a change-over switch
 - (d) One (1) watt meter 0-3,000 kW for main circuit
 - (e) One (1) set of group fault indicators
 - (f) Two (2) over current relays (51) for protection, suitable for tripping low over current rate
 - (g) One (1) over current ground relay (51G) for protection
 - (h) Test Terminal Blocks (TTB)
 - (i) One (1) NFB for spare
 - (j) Other necessary accessories

- (2) Spare parts

The following spare parts shall be furnished and quoted:

- (a) One (1) set of protective relays of each type.
- (b) One (1) set of meters of each type.
- (c) One (1) set of auxiliary relays, contactors, switches, timers, rheostats, rectifiers, etc. of each type.
- (d) One (1) lot of fuses for 500 per cent of supply
- (e) One (1) lot of indicating lamp and lenses

2.8 Miscellaneous Materials

2.8.1 Scope of Miscellaneous Materials

The miscellaneous materials to be supplied and installed are as follows:

- (1) Power cables and fittings
- (2) Control cables and fittings

- (3) Insulated wires and fittings
- (4) Bare copper conductors
- (5) Other materials
- (6) New cubicle earthing system
- (7) Outdoor lighting for new cubicle

2.8.2 Power Cables

All power cables shall be of single- or multi- core copper, PVC sheathed type with suitable cable ends. The power cables for 22 kV circuit shall have metal shield or have semiconducting tape and tinned copper wire shield.

The following power cables shall be supplied and installed by the Contractor:

- (1) 22 kV cross-linked polyethylene (XLPE) insulated cable of 100 mm² single-core or 150 mm² multi core type for 22 kV circuit.
- (2) Other power cables required for the equipment to be covered under this Contract shall also be supplied and installed by the Contractor. The minimum size of power cables shall be proposed by the Contractor.

2.8.3 Control Cables

The control cables shall be of jacket type 600 V polyvinyl chloride (PVC) insulated, PVC sheathed cables of single-core or multi-cores (CVV) for general use, with the sectional area of core not less than 1.5 mm².

2.8.4 Insulated Wires

600 V grade, PVC insulated wires (IV) may be used for power and space heater circuits for auxiliary equipment. The minimum size shall be 1.5 mm².

2.8.5 Bare Copper Conductor

Bare copper stranded wire shall be used for the earthing system. The size of earthing conductor shall be 50 mm².

2.8.6 Earthing Rod

Earthing rod shall be used for the earthing connected with earthing mesh. The size of earthing rod shall be of about 25 mm in diameter and 2 m long copper plated steel rod.

2.8.7 Other Materials

All cable trays and supporting brackets required for the installation of power cables and control cables shall be supplied and installed by the Contractor.

All other miscellaneous materials; such as conduit pipes, wooden cable cleats, angle steel, channel steel, steel plate, bolts, nuts and other items required for putting into service the Plant shall be supplied and installed as required according to the Consultant's instruction.

Section 3 Drawings

The following drawings are referred to design and supply of equipment.

The Contractor shall submit a necessary drawings, documents, calculation sheets, instruction & maintenance manuals, etc for approval.

3.1 Single Line Diagram for 22kV Power System of Mondul Kiri, EDC

3.2 Single Line Diagram for Interconnection Cubicle

Appendix 5 送配電技術

Appendix 5-1 : 送配電系統図 (2011 年 3 月時点)

Appendix 5-2 : 送配電設備位置図 (2011 年 3 月時点)

Appendix 5-3 : Evaluation Plan for Abilities of EUMP

Appendix 5-4 : 自己評価結果まとめ (第 1 回目)

Appendix 5-5 : 自己評価結果まとめ (第 2 回目)

Appendix 5-6 : 自己評価結果まとめ (第 3 回目)

Appendix 5-7 : アクションプラン結果 (英語訳)

Appendix 5-8 : 配電ロス計算方法

SINGLE LINE DIAGRAM FOR 22KV CIRCUIT

AS OF MARCH 2011

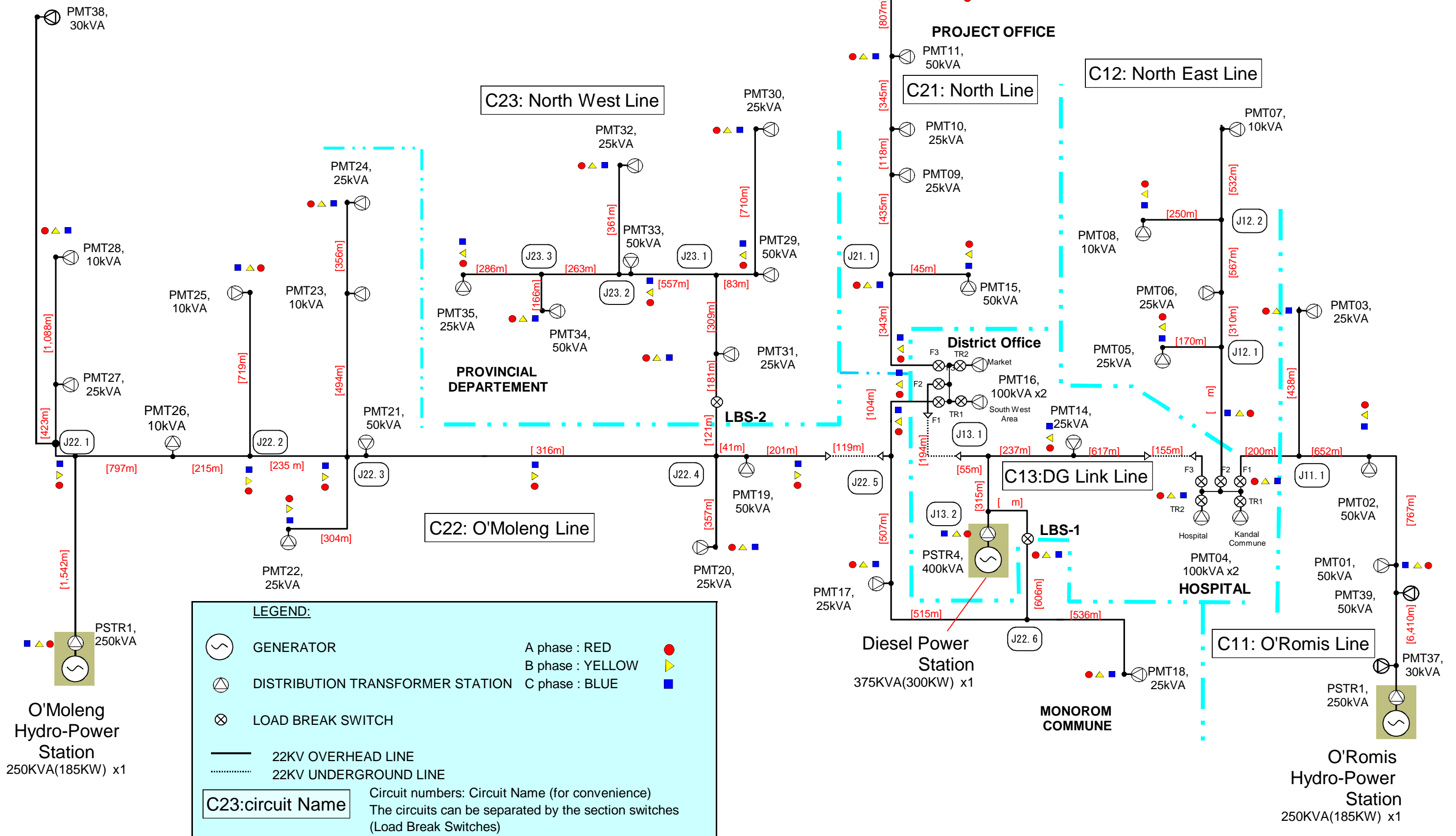

LEGEND:

	GENERATOR	A phase : RED	
	DISTRIBUTION TRANSFORMER STATION	B phase : YELLOW	
	LOAD BREAK SWITCH	C phase : BLUE	
	22KV OVERHEAD LINE		
	22KV UNDERGROUND LINE		

C23:circuit Name Circuit numbers: Circuit Name (for convenience)
 The circuits can be separated by the section switches (Load Break Switches)

THE PROJECT FOR OPERATION AND MAINTENANCE OF THE RURAL ELECTRIFICATION ON MYCRO-HYDROPOWER IN MONDUL KIRI

Distribution Line Location MAP

Senmonorom City
Senmonorom District
Mondul Kiri Province

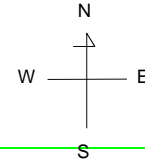

Total length of 22kV MVL :	27.8km
Total length of 400/230V LVL :	32.4km
Total number of Transformers	44 pcs
Distributiob Transformer	41 pcs
Step-up Transformer	3 pcs
Total capacity of Transformers	1,865 KVA

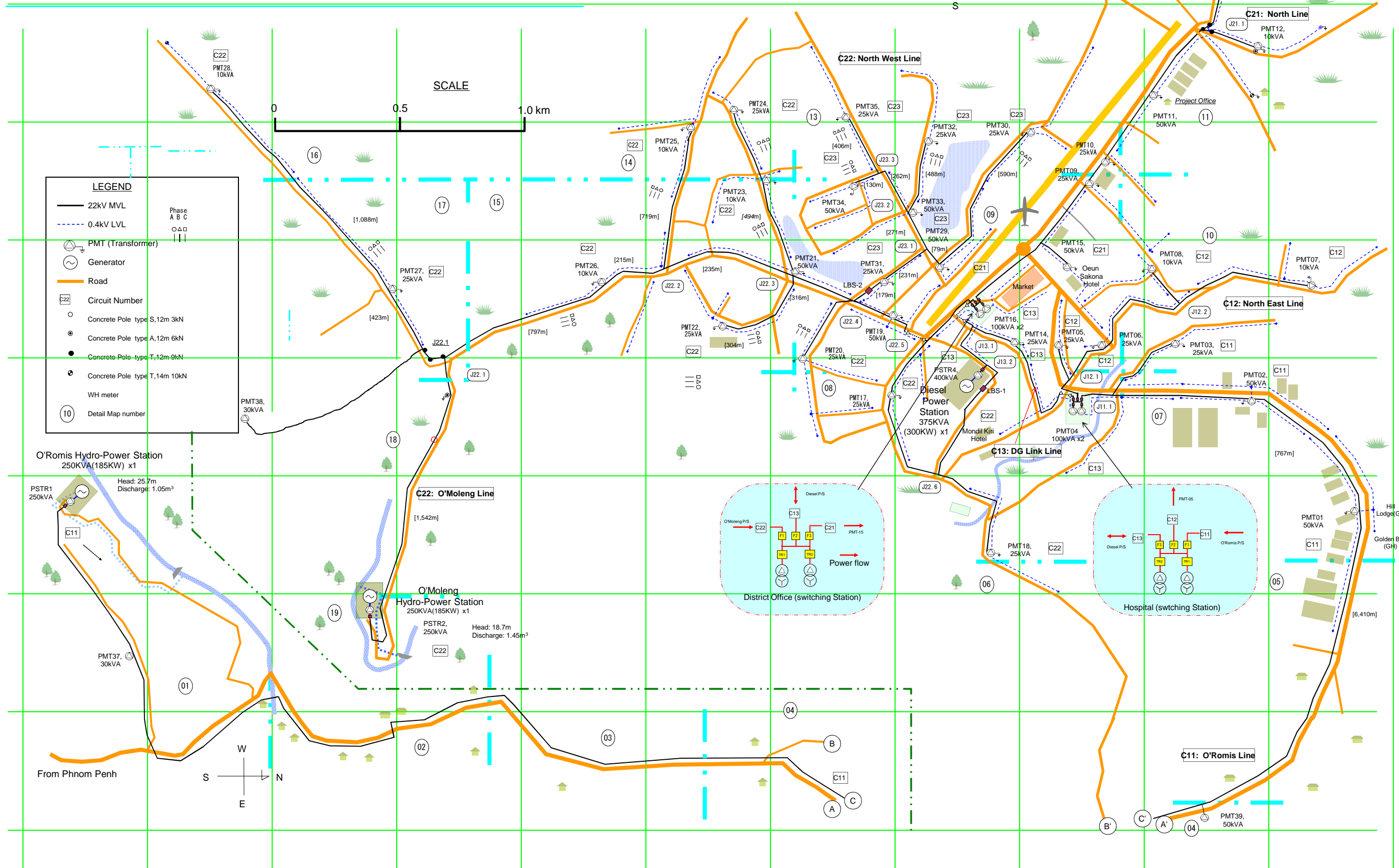

Evaluation Plan for Abilities of EUMP

Transmission and Distribution

May, 2010

JICA Advisor Team
Project for Operation and Maintenance
of the Rural Electrification on Micro-hydropower
in Mondul Kiri

1. Summary of Evaluation Plan for Transmission and Distribution Ability

- (1) Term of Evaluation: From May, 2010 until March, 2011
- (2) Evaluation Point of Time: 1st Point - May, 2010
2nd Point - September, 2010
3rd Point - February, 2011 (Final)
- (3) Target: Technical Personnel of EUMP
 - 1) Technical Division: 2 members
 - 2) T/L, D/L & Metering Section: 5 members

2. Evaluation Methodology

First Evaluation: May 2010

1) First Self-Evaluation by using Evaluation Sheet

Target person in charge conducts the first self-evaluation of items in Task Code by using "Evaluation Sheet". JICA advisor will give some suggestions.

2) Making out Action Plan

Based on the result of the first self-evaluation, target person in charge makes out each action plan to improve the ability of O&M and submits it to JICA Advisory team.

JICA advisor will give some suggestions.



Second Evaluation: September 2010

3) Interim Self-Evaluation

Target person in charge conducts the second self-evaluation by using "Evaluation Sheet" and modifies the action plan if needed.



Third Evaluation: December 2010

4) Final Self-Evaluation

Target person in charge conducts the third self-evaluation by using "Evaluation Sheet". And Target person in charge submits it and the result of action plan to JICA advisory team.

5) Advise by JICA team

JICA advisor will give some suggestions to improve their ability through interview.



Comprehensive Evaluation: February 2011

6) Comprehensive Evaluation

JICA advisor conducts comprehensive evaluation by using the report and attitude during OJT.

How to Check the Ability

To check the ability is the five-level rating system.

Rating: (High) A—B—C—D—E (Low)

Legend:

- A: 100~80% ⇒ I can completely do tasks and necessary O&M techniques of T/D.
- B: 79~60% ⇒ I can fairly do tasks and necessary O&M techniques with no instruction.
- C: 59~40% ⇒ I can completely do tasks for O&M with the instruction of T&D section Manager.
- D: 39~20% ⇒ I can completely do tasks for O&M with the instruction of Technical division Manager.
- E: 19% and below ⇒ I need more training for self-operation.

Result of Achievement Evaluation

Task Item & Code	Task Number	First Evaluation	Second Evaluation	Third Evaluation	Comprehensive Evaluation
1) Planning	①				
	②				
2) Measurement	①				
	②				
3) Scheduled Outage Operation	①				
	②				
	③				
	④				
	⑤				
4) Fault Outage Operation	①				
	②				
	③				
	④				
5) Maintenance	①				
	②				
	③				

	④ ⑤				
6) Customer's Request or Claim	① ② ③ ④				
7) Construction	① ② ③ ④ ⑤				
8) Customer Contract	① ② ③ ④ ⑤ ⑥				

Annex-1. Evaluation Sheet

Rating: (High) A—B—C—D—E (Low)

Check 1: Planning (Task Code: TT2)

- ① Do you have the capacity to make long and mid-term plan and budget?
- ② Do you have the capacity to make daily activity plan of operation, maintenance and construction?

Check 2: Measurement (Task Code: TT3)

- ① Do you have the capacity to analyze operation condition such as load, loss and voltage drop?
- ② Do you have the capacity to measure voltage and current?

Check 3: Scheduled Outage (Task Code: TT4)

- ① Do you have the capacity to make the switching procedure?
- ② Do you have the capacity to notify the scheduled outage to customers?
- ③ Do you have the capacity to order switching operation?
- ④ Do you have the capacity to operate the switch?
- ⑤ Do you have the capacity to record scheduled outage operation?

Check 4: Fault Outage (Task Code: TT5)

- ① Do you have the capacity to decide the method to restore?
- ② Do you have the capacity to order each action to restore?
- ③ Do you have the capacity to find and restore the fault?
- ④ Do you have the capacity to record fault outage operation?

Check 5: Maintenance (Task Code: TT6)

- ① Do you have the capacity to patrol and inspect T&D facility?
- ② Do you have the capacity to record patrol and inspection result?
- ③ Do you have the capacity to negotiate with owner of obstruct close to T&D line?
- ④ Do you have the capacity to control spare parts?
- ⑤ Do you have the capacity to maintain working tools?

Check 6: Customer's Request or Claim (Task Code: TT7)

- ① Do you have the capacity to deal with interruption of power supply?
- ② Do you have the capacity to deal with abnormal voltage?
- ③ Do you have the capacity to deal with Wh meter broken?
- ④ Do you have the capacity to deal with Wh meter checking?

Check 7: Construction (Task Code: TT8)

- ① Do you have the capacity to make a specification of constructions?
- ② Do you have the capacity to construct T&D facility?
- ③ Do you have the capacity to supervise construction work?
- ④ Do you have the capacity to inspect construction?
- ⑤ Do you have the capacity to update facility book?

Check 8: Customer Contract (Task Code: TT9)

- ① Do you have the capacity to do technical review of supply application?
- ② Do you have the capacity to do connection work?
- ③ Do you have the capacity to install Wh meter?
- ④ Do you have the capacity to deliver invoices to customers?
- ⑤ Do you have the capacity to do temporary disconnection & re-connection?
- ⑥ Do you have the capacity to remove Wh meter from ex-customer?

Annex -2 Format of Self-evaluation sheet

Division, Position _____

Name _____

Date, Place _____

Name of JICA Advisor _____

Task Item and Code Number	Number of Detailed Task	Grade of Evaluation	Reason or Comment	Check by JICA
1)	①	A B C D E		
	②	A B C D E		
2)	①	A B C D E		
	②	A B C D E		
3)	①	A B C D E		
	②	A B C D E		
	③	A B C D E		
	④	A B C D E		
	⑤	A B C D E		
4)	①	A B C D E		
	②	A B C D E		
	③	A B C D E		
	④	A B C D E		
5)	①	A B C D E		
	②	A B C D E		
	③	A B C D E		
	④	A B C D E		
	⑤	A B C D E		
6)	①	A B C D E		
	②	A B C D E		

	③ ④	A B C D E A B C D E		
7)	① ② ③ ④ ⑤	A B C D E A B C D E A B C D E A B C D E A B C D E		
8)	① ② ③ ④ ⑤ ⑥	A B C D E A B C D E A B C D E A B C D E A B C D E A B C D E		

Note: Number of detailed task shall be referred to Evaluation sheet

Result of the First Self-Evaluation for Transmission and Distribution Work on May 25, 2010

Item	Name	Mr. Chin Sokhun	Mr. Thai Khin	Mr. Theng Setha	Mr. Savuth Sothea	Mr. Ret Soksamdy	Mr. Reoum Navy	Mr. Tim Seanghi	Mr. Ros Panha	Mr. Ruos Samnang	Mr. So Sovannarith	Average
	Current Position	Deputy Director	Division Manager	Group Leader of DG Section	Section Manager	Group Leader	Operator	Operator at O'Romis Section	Operator (from January 2011)	Operator	Operator	
	Future Position after transferring EUMP to EDC	Director	Deputy Director	Division Manager	Section Manager	Group Leader	Operator	Operator	Opeator	Leave	Leave	
TT2 Planning	① Do you have the capacity to make long and mid-term plan and budget?	A	D	B	D	-	-	-	-	-	-	65%
	② Do you have the capacity to make daily activity plan of operation, maintenance and construction?	B	B	A	C	-	-	-	-	-	-	80%
TT3 Measurement	① Do you have the capacity to analyze operation condition such as load, loss and voltage drop?	A	A	A	C	C	B	B	C	B		80%
	② Do you have the capacity to measure voltage and current?	A	A	A	B	B	B	B	C	B		84%
TT4 Scheduled Outage	① Do you have the capacity to make the switching procedure?	A	A	A	B	C	C	B	D	B		78%
	② Do you have the capacity to notify the scheduled outage to customers?	A	A	A	B	C	A	B	C	B		84%
	③ Do you have the capacity to order switching operation?	A	A	A	B	C	D	C	C	B		76%
	④ Do you have the capacity to operate the switch?	A	A	A	B	B	B	B	C	B		84%
	⑤ Do you have the capacity to record scheduled outage operation?	A	A	A	B	B	B	B	C	B		84%
TT5 Fault Outage	① Do you have the capacity to decide the method to restore?	A	A	B	C	C	D	B	C	C		71%
	② Do you have the capacity to order each action to restore?	A	A	B	B	C	B	A	C	C		80%
	③ Do you have the capacity to find and restore the fault?	A	A	A	B	C	C	B	C	B		80%
	④ Do you have the capacity to record fault outage operation?	A	A	A	B	B	B	B	C	B		84%
TT6 Maintenance	① Do you have the capacity to patrol and inspect T&D facility?	A	A	A	B	B	A	A	C	B		89%
	② Do you have the capacity to record patrol and inspection result?	A	A	A	B	B	B	A	C	B		87%
	③ Do you have the capacity to negotiate with owner of obstruct close to T&D line?	A	A	B	B	B	A	B	B	C		84%
	④ Do you have the capacity to control spare parts?	A	A	A	C	C	D	D	C	C		69%
	⑤ Do you have the capacity to maintain working tools?	A	A	A	B	B	B	B	C	B		84%
TT7 Customer's Request or Claim	① Do you have the capacity to deal with interruption of power supply?	A	A	B	B	C	A	B	D	C		78%
	② Do you have the capacity to deal with abnormal voltage?	A	A	C	B	C	B	B	C	B		78%
	③ Do you have the capacity to deal with Wh meter broken?	A	A	A	B	B	A	B	C	B		87%
	④ Do you have the capacity to deal with Wh meter checking?	A	A	A	B	B	B	A	C	B		87%
TT8 Construction	① Do you have the capacity to make a specification of constructions?	B	D	B	C	D	D	B	D	B		60%
	② Do you have the capacity to construct T&D facility?	A	A	B	B	D	D	C	D	C		67%
	③ Do you have the capacity to supervise construction work?	A	A	A	C	D	D	B	D	B		71%
	④ Do you have the capacity to inspect construction?	A	A	B	B	D	D	B	D	B		71%
	⑤ Do you have the capacity to update facility book?	A	A	B	C	D	D	D	C	C		64%
TT9 Customer Contract	① Do you have the capacity to do technical review of supply application?	A	A	A	B	C	A	B	C	B		84%
	② Do you have the capacity to do connection work?	A	A	A	B	B	A	B	C	B		87%
	③ Do you have the capacity to install Wh meter?	A	A	A	B	B	A	A	C	B		89%
	④ Do you have the capacity to deliver invoices to customers?	A	A	A	B	B	A	A	C	B		89%
	⑤ Do you have the capacity to do temporary disconnection & re-connection?	A	A	A	B	B	A	A	C	B		89%
	⑥ Do you have the capacity to remove Wh meter from ex-customer?	A	A	A	B	B	A	A	C	B		89%

Legend: A 100%, B 80%, C 60%, D 40%, E 20%

: Selected item for Action Plan

* Mr. So Sovannarith was not in Mondul Kiri during the evaluation.

Result of the Interim Self-Evaluation for Transmission and Distribution Work on September 25, 2010

Item	Name Position	Mr. Savuth Sothea Section Manager	Mr. Ret Soksamdy Group Leader	Mr. Reoum Navy Operator	Mr. Tim Seanghi Operator	Mr. Ros Panha Operator	Mr. Sum Dara Operator(New)	Mr. Hang Rotha Operator(New)	Average
TT2 Planning	① Do you have the capacity to make long and mid-term plan and budget?	B	-	-	-	-	-	-	80%
	② Do you have the capacity to make daily activity plan of operation, maintenance and construction?	A	-	-	-	-	-	-	100%
TT3 Measurement	① Do you have the capacity to analyze operation condition such as load, loss and voltage drop?	A	A	A	B	A	C	B	89%
	② Do you have the capacity to measure voltage and current?	A	A	A	A	A	A	A	100%
TT4 Scheduled Outage	① Do you have the capacity to make the switching procedure?	A	A	B	B	A	B	B	89%
	② Do you have the capacity to notify the scheduled outage to customers?	A	A	A	A	A	A	A	100%
	③ Do you have the capacity to order switching operation?	A	A	B	A	A	B	A	94%
	④ Do you have the capacity to operate the switch?	A	A	B	A	A	A	A	97%
	⑤ Do you have the capacity to record scheduled outage operation?	A	A	A	A	A	A	A	100%
TT5 Fault Outage	① Do you have the capacity to decide the method to restore?	A	A	B	B	A	A	A	94%
	② Do you have the capacity to order each action to restore?	A	A	A	B	A	B	B	91%
	③ Do you have the capacity to find and restore the fault?	A	A	B	A	B	C	A	89%
	④ Do you have the capacity to record fault outage operation?	A	A	A	A	A	A	A	100%
TT6 Maintenance	① Do you have the capacity to patrol and inspect T&D facility?	A	A	A	A	A	A	A	100%
	② Do you have the capacity to record patrol and inspection result?	A	A	A	B	A	A	A	97%
	③ Do you have the capacity to negotiate with owner of obstruct close to T&D line?	A	A	A	A	A	A	A	100%
	④ Do you have the capacity to control spare parts?	A	A	A	B	A	A	B	94%
	⑤ Do you have the capacity to maintain working tools?	A	A	A	A	A	A	A	100%
TT7 Customer's Request or Claim	① Do you have the capacity to deal with interruption of power supply?	A	A	A	B	A	A	A	97%
	② Do you have the capacity to deal with abnormal voltage?	A	B	A	B	A	C	A	89%
	③ Do you have the capacity to deal with Wh meter broken?	A	A	A	A	A	A	A	100%
	④ Do you have the capacity to deal with Wh meter checking?	A	A	A	A	A	A	A	100%
TT8 Construction	① Do you have the capacity to make a specification of constructions?	B	B	B	B	B	C	B	77%
	② Do you have the capacity to construct T&D facility?	B	B	B	B	A	B	A	86%
	③ Do you have the capacity to supervise construction work?	C	A	B	B	A	B	B	83%
	④ Do you have the capacity to inspect construction?	C	A	C	B	A	C	B	77%
	⑤ Do you have the capacity to update facility book?	B	A	C	B	A	A	B	86%
TT9 Customer Contract	① Do you have the capacity to do technical review of supply application?	A	A	A	A	A	A	B	97%
	② Do you have the capacity to do connection work?	A	A	A	A	A	A	A	100%
	③ Do you have the capacity to install Wh meter?	A	A	A	A	A	A	B	97%
	④ Do you have the capacity to deliver invoices to customers?	A	A	A	A	A	A	A	100%
	⑤ Do you have the capacity to do temporary disconnection & re-connection?	A	A	A	A	A	A	A	100%
	⑥ Do you have the capacity to remove Wh meter from ex-customer?	A	A	A	A	A	A	A	100%

: Selected item for Action Plan

Result of the Final Self-Evaluation for Transmission and Distribution Work on December 15, 2010

Item	Name Position	Mr. Savuth Sothea Section Manager	Mr. Ret Soksamdy Group Leader	Mr. Roem Navy Operator	Mr. Thim Seanghai Operator	Mr. Ros Panha Operator→Warehouse in October	Mr. Som Dara Operator(New)	Mr. Hang Rotha Operator(New) absent	Average
TT2 Planning	① Do you have the capacity to make long and mid-term plan and budget?	A	-	-	-	-	-	-	100%
	② Do you have the capacity to make daily activity plan of operation, maintenance and construction?	A	-	-	-	-	-	-	100%
TT3 Measurement	① Do you have the capacity to analyze operation condition such as load, loss and voltage drop?	A	A	A	B	-	A	-	96%
	② Do you have the capacity to measure voltage and current?	A	A	A	A	-	A	-	100%
TT4 Scheduled Outage	① Do you have the capacity to make the switching procedure?	A	A	A	A	-	A	-	100%
	② Do you have the capacity to notify the scheduled outage to customers?	A	A	A	A	-	A	-	100%
	③ Do you have the capacity to order switching operation?	A	A	A	A	-	A	-	100%
	④ Do you have the capacity to operate the switch?	A	A	A	A	-	A	-	100%
	⑤ Do you have the capacity to record scheduled outage operation?	A	A	A	A	-	A	-	100%
TT5 Fault Outage	① Do you have the capacity to decide the method to restore?	A	A	A	A	-	A	-	100%
	② Do you have the capacity to order each action to restore?	A	A	A	A	-	B	-	96%
	③ Do you have the capacity to find and restore the fault?	A	A	A	A	-	B	-	96%
	④ Do you have the capacity to record fault outage operation?	A	A	A	A	-	A	-	100%
TT6 Maintenance	① Do you have the capacity to patrol and inspect T&D facility?	A	A	A	A	-	A	-	100%
	② Do you have the capacity to record patrol and inspection result?	A	A	A	A	-	A	-	100%
	③ Do you have the capacity to negotiate with owner of obstruct close to T&D line?	A	A	A	A	-	A	-	100%
	④ Do you have the capacity to control spare parts?	A	A	A	A	-	A	-	100%
	⑤ Do you have the capacity to maintain working tools?	A	A	A	A	-	A	-	100%
TT7 Customer's Request or Claim	① Do you have the capacity to deal with interruption of power supply?	A	A	A	A	-	A	-	100%
	② Do you have the capacity to deal with abnormal voltage?	A	A	A	A	-	B	-	96%
	③ Do you have the capacity to deal with Wh meter broken?	A	A	A	A	-	A	-	100%
	④ Do you have the capacity to deal with Wh meter checking?	A	A	A	A	-	A	-	100%
TT8 Construction	① Do you have the capacity to make a specification of constructions?	B	A	B	A	-	B	-	88%
	② Do you have the capacity to construct T&D facility?	A	B	A	A	-	B	-	92%
	③ Do you have the capacity to supervise construction work?	B	A	A	B	-	B	-	88%
	④ Do you have the capacity to inspect construction?	A	A	A	A	-	A	-	100%
	⑤ Do you have the capacity to update facility book?	A	A	A	A	-	A	-	100%
TT9 Customer Contract	① Do you have the capacity to do technical review of supply application?	A	A	A	A	-	A	-	100%
	② Do you have the capacity to do connection work?	A	A	A	A	-	A	-	100%
	③ Do you have the capacity to install Wh meter?	A	A	A	A	-	A	-	100%
	④ Do you have the capacity to deliver invoices to customers?	A	A	A	A	-	A	-	100%
	⑤ Do you have the capacity to do temporary disconnection & re-connection?	A	A	A	A	-	A	-	100%
	⑥ Do you have the capacity to remove Wh meter from ex-customer?	A	A	A	A	-	A	-	100%

: Selected item for Action Plan

Division and Position	Name
Chief of T&D Section	Mr. Savuth Sothea

1 st Interview for setting Action Plan	2 nd Interview for Interim	3 rd Interview for Final
Date: 25-05-2010	Date: 25-09-2010	Date: 15-12-2010
Sign:	Sign:	Sign:

○ Action Plan

Objective item	Achievement Level		C/P			JICA Advisor Team	
	Current Level	Target Level	Measures	Interim Result	Final Result	Rating	Evaluation
(Task code TT6) No. 4 Spare parts Control	I do not understand the spare parts control.	<p>What? Spare parts control</p> <p>By When 30-10-2010</p> <p>How Far? I can control the spare parts management by myself.</p>	<p>How?</p> <ul style="list-style-type: none"> - To cooperate with procurement and Administration section - To prepare the list in order to control spare parts apparently 	<ul style="list-style-type: none"> - I collaborated with procurement and administration section for making a list of warehouse carry-out - I made the list of incoming and outgoing of watt hour meters that were broken or removed from the customer's house to warehouse. - I manage all of T&D spare parts in warehouse to be in good order and I will try my best to study it more with procurement and administration section. 	<ul style="list-style-type: none"> - I can manage spare parts and cooperate with procurement and administration almost 100% such as: <ul style="list-style-type: none"> ➢ Making list of receiving materials ➢ List of removed and installed meter conducted the suspension work ➢ List of checking consumer's houses before making a new connection work ➢ Make the list of proposal warehouse spare parts ➢ List of meter condition when we did the connection work to the new customer ➢ Record of meter checking and testing of customer ➢ Even report list ➢ Table of disconnection and reconnection of the customers who have not yet paid the electric charge each month - I cooperated with procurement section to manage the spare parts in warehouse in good order and I will try to get more new experiences from JICA team. 	<p>A</p> <p>B</p> <p>C</p> <p>D</p> <p>E</p>	<ul style="list-style-type: none"> ➢ After his efforts, he can manage and control spare parts under cooperation with procurement and administration section. ➢ He understands how to keep good condition and organize spare parts now.

Division and Position	Name
Deputy Chief of T&D Section	Mr. Ret Soksamdy

1 st Interview for setting Action Plan	2 nd Interview for Interim	3 rd Interview for Final
Date: 25-05-2010	Date: 22-09-2010	Date: 14-12-2010
Sign:	Sign:	Sign:

○ Action Plan

Objective item	Achievement Level		C/P			JICA Advisor Team	
	Current Level	Target Level	Measures	Interim Result	Final Result	Rating	Evaluation
(Task code TT8) No. 4 Inspection of the construction work	I do not understand the inspection of construction work.	<p>What? Inspection of Construction work</p> <p>By When 30-10-2010</p> <p>How Far? I can conduct the inspection of construction work by myself.</p>	<p>How?</p> <ul style="list-style-type: none"> - To cooperate with technical division, procurement and Administration section - To check the construction work whether it meets the standard of the construction or not 	- I can inspect the construction work of T&D facility according to my own capacity and practice through the suggestions and recommendations from JICA Team.	<ul style="list-style-type: none"> - I can do the inspection of construction work properly with technical standard by my ability that I have complied with the recommendations and instructions from JICA team. - And I conducted the actual inspection of the construction work by EM construction in September 2010 such as: <ul style="list-style-type: none"> ➤ Inspecting of new pole installation ➤ Checking the depth of pole installing and pole foundation 	<input type="checkbox"/> A <input type="checkbox"/> B <input type="checkbox"/> C <input type="checkbox"/> D <input type="checkbox"/> E	<ul style="list-style-type: none"> ➤ He understands what the points to check the construction work now are. ➤ He successfully conducted inspection in September.

Division and Position	Name
Member of T&D section	Mr. Thim Seang Hai

1 st Interview for setting Action Plan	2 nd Interview for Interim	3 rd Interview for Final
Date: 25-05-2010	Date: 22-09-2010	Date: 14-12-2010
Sign:	Sign:	Sign:

○ Action Plan

Objective item	Achievement Level		C/P			JICA Advisor Team	
	Current Level	Target Level	Measures	Interim Result	Final Result	Rating	Evaluation
(Task code TT8) No. 5 - Update of Facility Book	I do not understand how to update the facility book.	What? Update the Facility Book	How? - To cooperate with technical, procurement and administration section - To make a list for control - To get the information from the contractor to know time, location and specification of installation	- I collaborated with technical section for making the list for control and got the information from the technical section about time, location of installation for revising the T&D map.	- After getting the instruction from JICA team, I could update the facility book very well such as: ➤ Single Line Diagram ➤ Geographical Map ➤ Managing original document	A B C D E	➤ He updated maps for operation and maintenance of distribution facilities. ➤ He understood how to manage the original.
		By When 01-10-2010					
		How Far? I can control and update the facility book by myself.					

Division and Position	Name
Member of T&D Section	Mr. Roem Navy

1 st Interview for setting Action Plan	2 nd Interview for Interim	3 rd Interview for Final
Date: 25-05-2010	Date: 23-09-2010	Date: 15-12-2010
Sign:	Sign:	Sign:

○ Action Plan

Objective item	Achievement Level		C/P			JICA Advisor Team	
	Current Level	Target Level	Measures	Interim Result	Final Result	Rating	Evaluation
(Task code TT8) No. 2 Construction of T&D Facility	I do not know how to construct T&D facility.	<p>What? Construction work</p> <p>By When 30-10-2010</p> <p>How Far? I can conduct the construction of T&D facility by myself.</p>	<p>How?</p> <ul style="list-style-type: none"> - To cooperate with technical and procurement section - To communicate with customer - To communicate with Authorization - To calculate budget for the plan 	<ul style="list-style-type: none"> - I communicated with customer. - I communicated with Authorization. - I made the budget for the plan of expense. - I collaborated with procurement section. 	<ul style="list-style-type: none"> - After study and actual practicing, I can do the construction work of T&D facility well. - I went to study the location condition apparently. - I communicated with Authorization and customer. - I communicated with procurement and administration section. - I calculated the budget for the plan of expansion. - I understood the procedure of T&D construction work. - I clearly understood the specifications of cable and pole. - I will study the technical standards of T&D construction work and controlling of technical equipment. 	<ul style="list-style-type: none"> ➤ A ➤ B ➤ C ➤ D ➤ E 	<ul style="list-style-type: none"> ➤ He understands how to select the pole by technical calculation such as strength and length. ➤ He made an extension plan.

Division and Position	Name
Member of T&D Section	Mr. Ros Panha

1 st Interview for setting Action Plan	2 nd Interview for Interim	3 rd Interview for Final
Date: 25-05-2010	Date: 25-09-2010	Date: 15-12-2010
Sign:	Sign:	Sign:

○ Action Plan

Objective item	Achievement Level		C/P			JICA Advisor Team	
	Current Level	Target Level	Measures	Interim Result	Final Result	Rating	Evaluation
(Task code TT9) No. 1 Technical Review of Supply Application	I have no capacity to do the technical review of supply application	<p>What? Technical Review of Supply Application</p> <p>By When 30-10-2010</p> <p>How Far? I can understand and conduct the technical review of supply application by my self</p>	<p>How?</p> <ul style="list-style-type: none"> - To study and know the electric equipment in the customer house - To know how much capacity of the electric equipment in the customer - To study how to calculate the necessary capacity of the transformer 	- I understand well on the Technical review of supply application.	- After studying, I tried to research and understand. - I clearly understand the “technical review of supply application” now.	<input type="checkbox"/> A <input type="checkbox"/> B <input type="checkbox"/> C <input type="checkbox"/> D <input type="checkbox"/> E	<p>➤ He understands how to calculate the customer demand now.</p> <p>Ref: He moved to Warehouse in October.</p>