

2

A-4-31

4

Handwritten signature

Handwritten initials

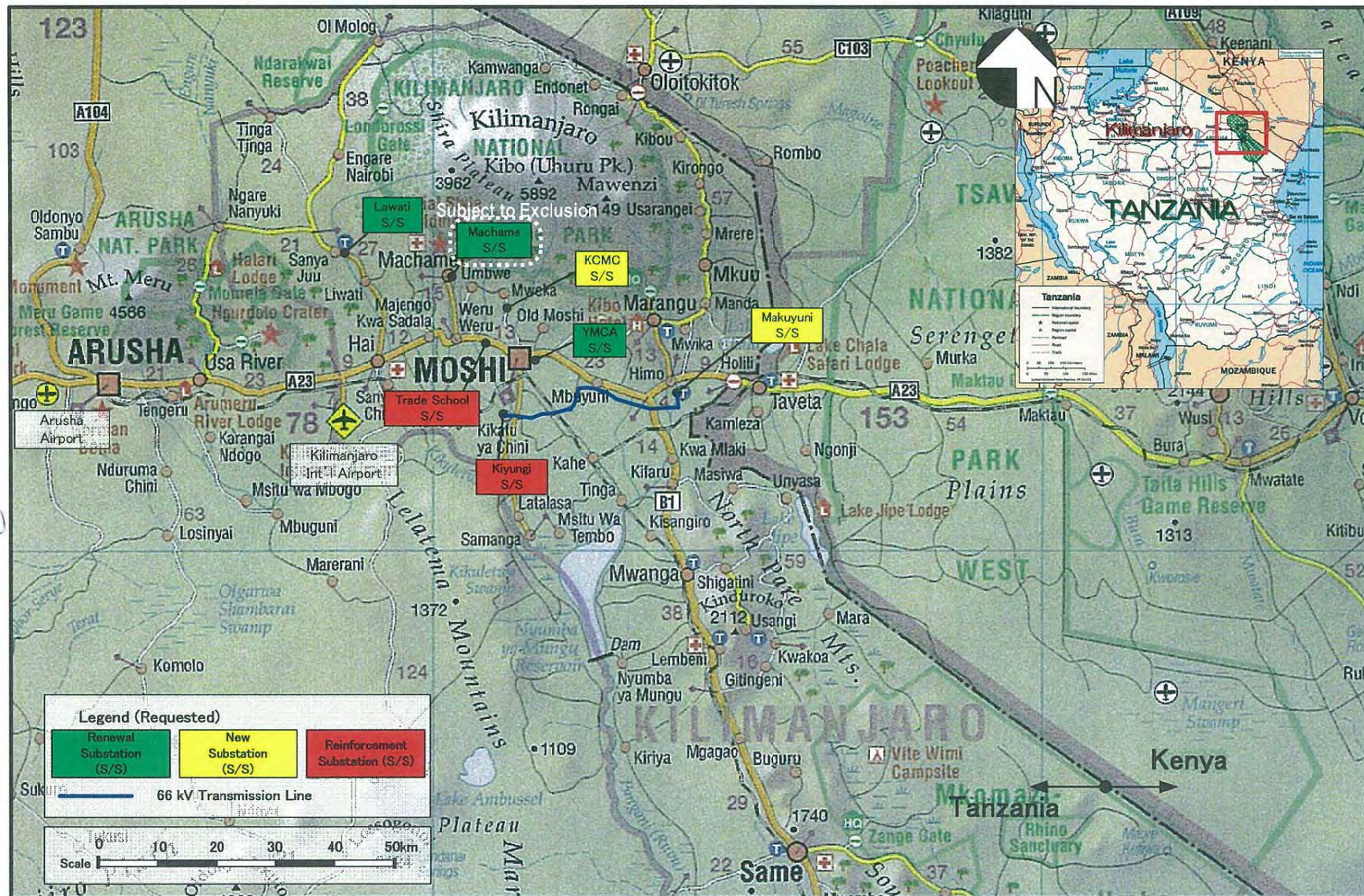

Project Sites

Annex-1

Detailed Contents of Components to be Covered by the Project

- A. 33/11kV, 17MVA Transformer Substation at YMCA**
- a) 33kV Incoming switchgear panel with VCB (1 No.)
 - b) 33/11kV, 17MVA (ONAN) Transformer with On-load Tap-changer (1 No.)
 - c) 11kV switchgear panel (6 Nos.)
 - Transformer secondary (1 No.)
 - Line feeder (3 Nos.)
 - Station supply transformer (1 No.)
 - LV supply and control (1 No.)
 - d) 33kV Cable and end treatment material (1 Lot)
 - e) 11kV Cable and end treatment material (1 Lot)
 - f) Miscellaneous (1 Lot)
 - g) Civil and Installation work (1 Lot)
- B. 33/11kV, 10MVA Transformer Substation at Lawate**
- a) 33kV Incoming switchgear panel with VCB (1 No.)
 - b) 33/11kV, 10MVA Transformer with On-load Tap-changer (1 No.)
 - c) 11kV switchgear panel (6 Nos.)
 - Transformer secondary (1 No.)
 - Line feeder (3 Nos.)
 - Station supply transformer (1 No.)
 - LV supply and control (1 No.)
 - d) 33kV Cable and end treatment material (1 Lot)
 - e) 11kV Cable and end treatment material (1 Lot)
 - f) Miscellaneous (1 Lot)
 - g) Civil and Installation work (1 Lot)
- C. 33/11kV, 10MVA Transformer Substation at KCMC**
- a) 33kV incoming switchgear panel with VCB (3 Nos.)
 - b) 33/11kV, 10MVA Transformer with On-load Tap-changer (1 No.)
 - c) 11kV switchgear panel (6 Nos.)
 - Transformer secondary (1 No.)
 - Line feeder (3 Nos.)
 - Station supply transformer (1 No.)
 - LV supply and control (1 No.)
 - d) 33kV Cable and end treatment material (1 Lot)
 - e) 11kV Cable and end treatment material (1 Lot)
 - f) Miscellaneous (1 Lot)
 - g) Civil and Installation work (1 Lot)

D. 33kV Outgoing bay at Trade School substation

- a) 33kV Outgoing switchgear panel with VCB (1 No.)
- b) 33kV Cable and end treatment material (1 Lot)
- c) Civil and Installation work (1 Lot)

E. Installation of 33kV distribution line from Trade School to KCMC (5 km)

F. 66/33kV, 20MVA Transformer Substation at Makuyuni

- a) 66kV Incoming line bay with GCB, etc. (1 Lot)
- b) 66kV Transformer bay (2 Lots)
- c) 66/33kV, 10MVA Transformer with On-load Tap-changer (2 Nos.)
- d) 33kV switchgear panel (7 Nos.)
 - Transformer secondary (2 Nos.)
 - Line feeder (4 Nos.)
 - Station supply transformer (1 No.)
- e) 66kV Control and protection panel (3 Nos.)
- f) 33kV Control and protection panel (6 Nos.)
- g) DC Supply Equipment (1 Set)
- h) 66kV Conductor (1 Lot)
- i) 33kV Cable and end treatment material (1 Lot)
- j) Miscellaneous (1 Lot)
- k) Civil, Building and Installation work (1 Lot)

Remarks: Excluding SCADA and data transfer system for Makuyuni substation

G. 66kV Outgoing bay at Kiyungi

- a) 66kV transmission line with GCB (1 Lot)
- b) 66kV Control panel (1 No.)
- c) Civil and Installation work (1 Lot)

H. Installation of New 66kV transmission line from Kiyungi to Makuyuni (34km)

I. Installation of 132/66kV, 20MVA transformer at Kiyungi substation

- a) 132/66kV, 20MVA transformer with On-load tap changer (1 No.)
- b) 132kV switch gear (1 Lot)
- c) 66kV switch gear (1 Lot)
- d) 66kV line switch (bus section) (1 Lot)
- e) 132kV Control and Protection panel (1 No.)
- f) 66kV Control and Protection panel (1 No.)
- g) Miscellaneous (1 Lot)
- h) Civil and Installation work (1 Lot)

(E)



J. 33/11kV, 10MVA Transformer Substation at Machame (subject to exclusion if required)

- a) 33kV Incoming switchgear panel with VCB (1 No.)
- b) 33/11kV, 10MVA Transformer with On-load Tap-changer (1 No.)
- c) 11kV switchgear panel (6 Nos.)
 - Transformer secondary (1 No.)
 - Line feeder (3 Nos.)
 - Station supply transformer (1 No.)
 - LV supply and control (1 No.)
- d) 33kV Cable and end treatment material (1 Lot)
- e) 11kV Cable and end treatment material (1 Lot)
- f) Miscellaneous (1 Lot)
- g) Civil and Installation work (1 Lot)

ⓐ

to 8

7

A-4-34

per

PM

ea

A-4-35

8

Handwritten signature

Handwritten signature

Handwritten signature

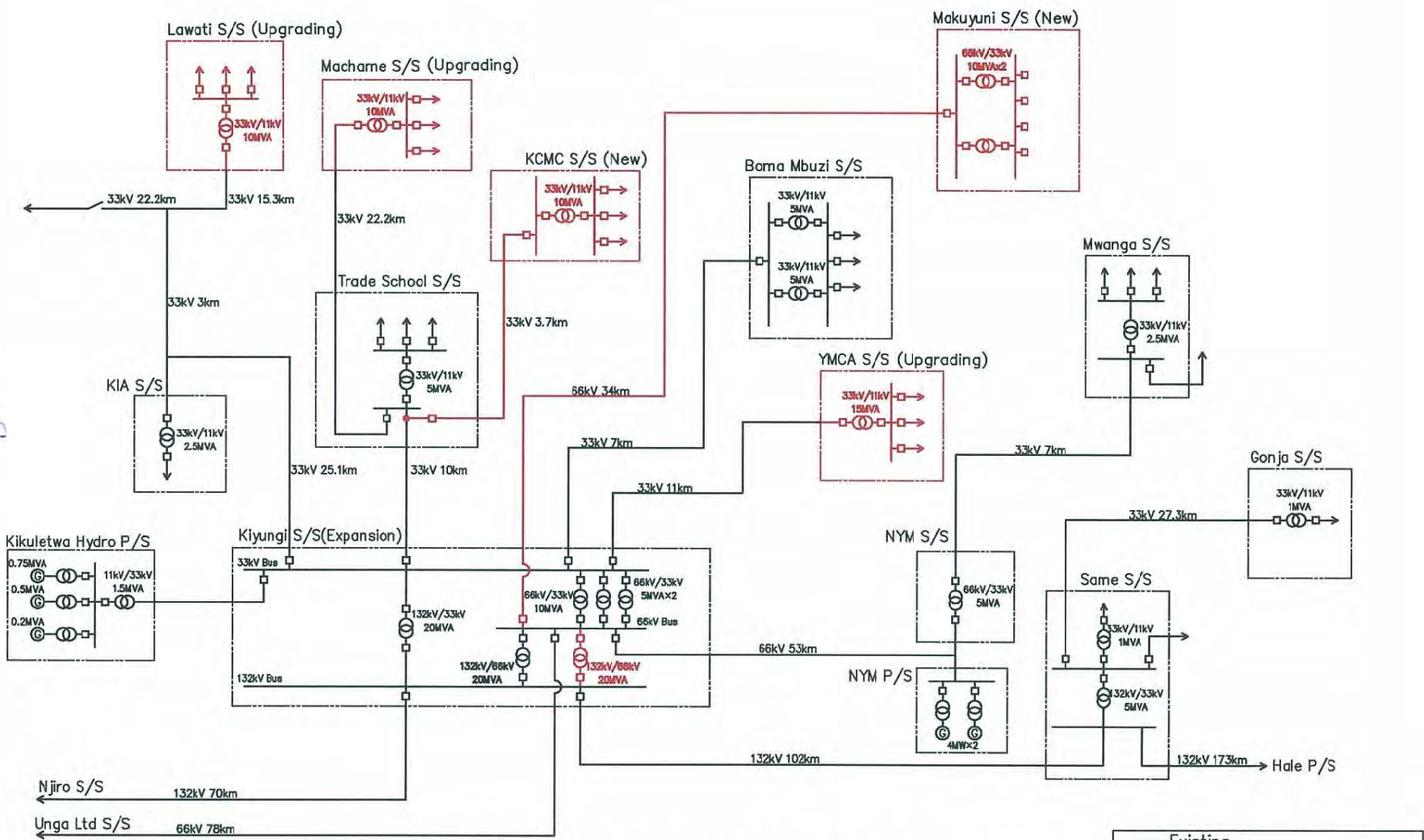

Components to be Covered by the Project

| | |
|--|----------------------|
| | Existing |
| | Scope of the Project |

JAPAN'S GRANT AID

The Government of Japan (hereinafter referred to as “the GOJ”) is implementing the organizational reforms to improve the quality of ODA operations, and as a part of this realignment, a new JICA law was entered into effect on October 1, 2008. Based on the law and the decision of the Government of Japan (hereinafter referred to as “the GOJ”), JICA has become the executing agency of the Grant Aid for General Projects, for Fisheries and for Cultural Cooperation, etc.

The Grant Aid is non-reimbursable fund to a recipient country to procure the facilities, equipment and services (engineering services and transportation of the products, etc.) for economic and social development of the country under principles in accordance with the relevant laws and regulations of Japan. The Grant Aid is not supplied through the donation of materials as such.

1. Grant Aid Procedures

The Japanese Grant Aid is conducted as follows-

- Preparatory Survey (hereinafter referred to as “the Survey”)
 - The Survey conducted by JICA
- Appraisal & Approval
 - Appraisal by the GOJ and JICA, and Approval by the Japanese Cabinet
- Determination of Implementation
 - The Notes exchanged between the GOJ and a recipient country
- Grant Agreement (hereinafter referred to as “the G/A”)
 - Agreement concluded between JICA and a recipient country
- Implementation
 - Implementation of the Project on the basis of the G/A

2. Preparatory Survey

(1) Contents of the Survey

The aim of the Survey is to provide a basic document necessary for the appraisal of the Project by JICA and the GOJ. The contents of the Survey are as follows:

- Confirmation of the background, objectives, and benefits of the Project and also institutional capacity of agencies concerned of the recipient country necessary for the implementation of the Project.
- Evaluation of the appropriateness of the Project to be implemented under the Grant Aid Scheme from a technical, financial, social and economic point of view.
- Confirmation of items agreed on by both parties concerning the basic concept of the Project.
- Preparation of a outline design of the Project.
- Estimation of costs of the Project.

The contents of the original request by the recipient country are not necessarily approved in their initial form as the contents of the Grant Aid project. The Outline Design of the Project is confirmed considering the guidelines of the Japan's Grant Aid scheme.

JICA requests the Government of the recipient country to take whatever measures are necessary

9

to ensure its self-reliance in the implementation of the Project. Such measures must be guaranteed even though they may fall outside of the jurisdiction of the organization in the recipient country actually implementing the Project. Therefore, the implementation of the Project is confirmed by all relevant organizations of the recipient country through the Minutes of Discussions.

(2) Selection of Consultants

For smooth implementation of the Survey, JICA uses (a) registered consulting firm(s). JICA selects (a) firm(s) based on proposals submitted by interested firms.

(3) Result of the Survey

The Report on the Survey is reviewed by JICA, and after the appropriateness of the Project is confirmed, JICA recommends the GOJ to appraise the implementation of the Project.

3. Japan's Grant Aid Scheme

(1) The E/N and the G/A

After the Project is approved by the Cabinet of Japan, the Exchange of Notes (hereinafter referred to as "the E/N") will be signed between the GOJ and the Government of the recipient country to make a plea for assistance, which is followed by the conclusion of the G/A between JICA and the Government of the recipient country to define the necessary articles to implement the Project, such as payment conditions, responsibilities of the Government of the recipient country, and procurement conditions.

(2) Selection of Consultants

The consultant firm(s) used for the Survey will be recommended by JICA to the recipient country to also work on the Project's implementation after the E/N and the G/A, in order to maintain technical consistency.

(3) Eligible source country

Under the Japanese Grant Aid, in principle, Japanese products and services including transport or those of the recipient country are to be purchased. When JICA and the Government of the recipient country or its designated authority deem it necessary, the Grant Aid may be used for the purchase of the products or services of a third country. However, the prime contractors, namely, constructing and procurement firms, and the prime consulting firm are limited to "Japanese nationals".

(4) Necessity of "Verification"

The Government of the recipient country or its designated authority will conclude contracts denominated in Japanese yen with Japanese nationals. Those contracts shall be verified by JICA. This "Verification" is deemed necessary to secure accountability to Japanese taxpayers.

(5) Major undertakings to be taken by the Government of the Recipient Country

In the implementation of the Grant Aid Project, the recipient country is required to undertake such necessary measures as Annex-4.

(6) "Proper Use"

The Government of the recipient country is required to maintain and use the facilities constructed and the equipment purchased under the Grant Aid properly and effectively and to assign staff necessary for this operation and maintenance as well as to bear all the expenses other than those covered by the Grant Aid.

(7) "Export and Re-export"

The products purchased under the Grant Aid should not be exported or re-exported from the recipient country.

(8) Banking Arrangements (B/A)

- a) The Government of the recipient country or its designated authority should open an account in the name of the Government of the recipient country in a bank in Japan (hereinafter referred to as "the Bank"). JICA will execute the Grant Aid by making payments in Japanese yen to cover the obligations incurred by the Government of the recipient country or its designated authority under the Verified Contracts.
- b) The payments will be made when payment requests are presented by the Bank to JICA under an Authorization to Pay (A/P) issued by the Government of the recipient country or its designated authority.

(9) Authorization to Pay (A/P)

The Government of the recipient country should bear an advising commission of an Authorization to Pay and payment commissions to the Bank.

(10) Social and Environmental Considerations

A recipient country must ensure the social and environmental considerations for the Project and must follow the environmental regulation of the recipient country and JICA socio-environmental guideline.

(End)

①

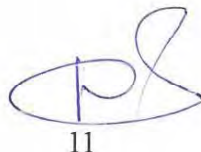
11

A-4-38



Major Undertakings to be taken by Each Government

| No. | Items | To be covered by Grant Aid | To be covered by Recipient Side |
|-----|--|----------------------------|---------------------------------|
| 1 | to secure [a lot] /[lots] of land necessary for the implementation of the Project and to clear the [site]/[sites]; | | ● |
| 2 | To construct the following facilities | | |
| | 1) The building | ● | |
| | 2) The gates and fences in and around the site | ● | |
| | 3) The parking lot | ● | |
| | 4) The road within the site | ● | |
| | 5) The road outside the site (including Access road) | | ● |
| 3 | To provide facilities for distribution of electricity, water supply and drainage and other incidental facilities necessary for the implementation of the Project outside the [site]/[sites] | | |
| | 1)Electricity | | |
| | a. The distributing power line to the site | ● | |
| | b. The drop wiring and internal wiring within the site | ● | |
| | c. The main circuit breaker and transformer | ● | |
| | 2) Water Supply | | |
| | a. The city water distribution main to the site | | ● |
| | b. The supply system within the site (receiving and elevated tanks) | ● | |
| | 3) Drainage | | |
| | a. The city drainage main (for storm sewer and others to the site) | | ● |
| | b. The drainage system (for toilet sewer, common waste, storm drainage and others) within the site | ● | |
| | 4) Gas Supply | | |
| | a. The city gas main to the site | n/a | n/a |
| | b. The gas supply system within the site | n/a | n/a |
| | 5) Telephone System | | |
| | a. The telephone trunk line to the main distribution frame/panel (MDF) of the building | | ● |
| | b. The MDF and the extension after the frame/panel | ● | |
| | 6) Furniture and Equipment | | |
| | a. General furniture | | ● |
| | b. Project equipment | ● | |
| 4 | To ensure prompt unloading and customs clearance of the products at ports of disembarkation in the recipient country and to assist internal transportation of the products | | |
| | 1) Marine (Air) transportation of the Products from Japan to the recipient country | ● | |
| | 2) Tax exemption and custom clearance of the Products at the port of disembarkation | | ● |
| | 3) Internal transportation from the port of disembarkation to the project site | ● | |
| 5 | To ensure that customs duties, internal taxes and other fiscal levies which may be imposed in the recipient country with respect to the purchase of the products and the services [be exempted] / [be borne by the Authority without using the Grant] | | ● |
| 6 | To accord Japanese nationals whose services may be required in connection with the supply of the products and the services such facilities as may be necessary for their entry into the recipient country and stay therein for the performance of their work | | ● |
| 7 | To ensure that [the Facilities and the products]/[the Facilities]/ [the products] be maintained and used properly and effectively for the implementation of the Project | | ● |
| 8 | To bear all the expenses, other than those covered by the Grant, necessary for the implementation of the Project | | ● |
| 9 | To bear the following commissions paid to the Japanese bank for banking services based upon the B/A | | |
| | 1) Advising commission of A/P | | ● |
| | 2) Payment commission | | ● |
| 10 | To give due environmental and social consideration in the implementation of the Project. | | ● |

⑨



12

A-4-39



Project Cost Estimation (Confidential)

This cost estimate is provisional and would be further examined by the Government of Japan for the approval of the Grant Aid.

This page is closed due to the confidentiality

⑨



13

A-4-40



資料－5 参考資料／入手資料リスト

| 番号 | 名称 | 形態 図書・ビデオ・ 地図・写真等 | オリジナル・ コピー | 発行機関 | 発行年 |
|----|--|-------------------------|---------------|---|-----------|
| 1 | OTHER PROJECTS FOR TRANSMISSION SUBSTATION AND DISTRIBUTION IN KILIMANJARO REGION. | 文書 | コピー | TANESCO | |
| 2 | EIA and Audit regulations - 2005 | 文書 | コピー | TANESCO | 2005 |
| 3 | EMA Act 2004 | 文書 | コピー | TANESCO | Jun. 2004 |
| 4 | Budget Kilimanjaro | 文書 | コピー | TANESCO | 2010 |
| 5 | Financial Statement 2004 | 図書 | コピー | TANESCO | Dec. 2004 |
| 6 | Financial Statement 2005 | 図書 | コピー | TANESCO | Dec. 2005 |
| 7 | Financial Statement 2006 | 図書 | コピー | TANESCO | Dec. 2006 |
| 8 | Financial Statement 2007 | 図書 | コピー | TANESCO | Dec. 2007 |
| 9 | Financial Statement 2008 | 図書 | コピー | TANESCO | Dec. 2008 |
| 10 | MANAGEMENT DEVELOPMENT PLAN | 文書 | コピー | TANESCO | |
| 11 | Power System Master Plan – 2009 Update – Executive Summary | 文書 | コピー | TANESCO | 2009 |
| 12 | Power System Master Plan – 2009 Update | 図書 | コピー | Government of the United Republic of Tanzania | Aug. 2009 |

| 番号 | 名称 | 形態 図書・ビデオ・ 地図・写真等 | オリジナル・ コピー | 発行機関 | 発行年 |
|----|---|-------------------------|---------------|---------|-----------|
| 13 | Construction Cost 66kV, 33kV | 文書 | コピー | TANESCO | |
| 14 | PROBLEMS /CONSTRAINTS THAT CAUSES STOPPAGE OR MALFUNCTION OF O&M OF THE ENTITY | 文書 | コピー | TANESCO | |
| 15 | PLANT AND EQUIPMENT SPECIFICATION S01 GENERAL TECHNICAL REQUIREMENTS OF 33KV, 11KV AND LV NETWORKS | 図書 | コピー | TANESCO | Mar. 2005 |
| 16 | Construction Section Instructions Manual | 図書 | コピー | TANESCO | Oct. 2007 |
| 17 | Substation Section Instructions Manual | 図書 | コピー | TANESCO | Oct. 2007 |
| 18 | <ul style="list-style-type: none"> • CONSTRUCTION AND INSTALLATION STANDARDS FOR SUBSTATIONS • SYSTEM DESCRIPTION • SYSTEM OPERATIONAL REGULATIONS | 文書 | コピー | TANESCO | |
| 19 | CORPORATE BUSINESS PLAN (2010 - 2014) | 図書 | コピー | TANESCO | Dec. 2009 |
| 20 | Tariffs of TANESCO 2009 | 図書 | コピー | TANESCO | 2009 |
| 21 | Operational Income and Expenditure Budget of Kilimanjaro | 文書 | コピー | TANESCO | 2009 |
| 22 | Operational Income and Expenditure Budget of Tanzania | 文書 | コピー | TANESCO | 2009 |
| 23 | POPULATION DISTRIBUTION IN KILIMANJARO REGION | 文書 | コピー | TANESCO | 2009 |
| 24 | HEALTH AND SAFETY POLICY of TANESCO | 図書 | コピー | TANESCO | Jul. 2008 |

| 番号 | 名称 | 形態 図書・ビデオ・ 地図・写真等 | オリジナル・ コピー | 発行機関 | 発行年 |
|----|--|-------------------------|---------------|---|-----------|
| 25 | Meteorological Data | 文書 | コピー | Tanzania Meteorological Agency | |
| 26 | Resettlement Policy Framework 400 kV Power Transmission Line Project Iringa - Dodoma - Singida - Shinyanga | 図書 | コピー | Institute of Resource Assessment | Nov. 2009 |
| 27 | Tanzania-Analytical Report of 2002 Population Census Volume X | 図書 | コピー | National Bureau of Statistics Ministry of Planning, Economy and Empowerment | Aug. 2006 |
| 28 | Kilimanjaro Regional and District Projections Volume XII | 図書 | コピー | National Bureau of Statistics Ministry of Planning, Economy and Empowerment | Dec. 2006 |
| 29 | Population by Village, 5 Year Age Group and Sex in Kilimanjaro Region | 文書 | コピー | National Bureau of Statistics Ministry of Planning, Economy and Empowerment | |
| 30 | Kiyungi Substation Monthly Report (Jan-June, 2010) | 文書 | コピー | TANESCO | 2010 |
| 31 | Valuation Report For Compensation Purposes Makuyuni | 文書 | コピー | Moshi Municipal Council | Mar. 2010 |
| 32 | DISTRIBUTION NETWORK FOR KILIMANJARO REGION | 図面 | コピー | TANESCO | Nov. 2007 |
| 33 | National Grid System | 図面 | コピー | TANESCO | Aug. 2009 |
| 34 | REQUEST FOR PROPOSAL FOR CONSULTANCY SERVICES FOR NEW 132 kV KILIMANJARO-ARUSHA TRANSMISSION LINE AND REHABILITATION OF KIYUNGI SUBSTATION PROJECT | 図書 | コピー | TANESCO | Apr. 2010 |
| 35 | THE ELECTRICITY ACT | 文書 | コピー | Ministry of Energy and Minerals | Apr. 2008 |

資料－6 EIA 登録申請書

NATIONAL ENVIRONMENT MANAGEMENT COUNCIL

ENVIRONMENTAL IMPACT ASSESSMENT REGISTRATION FORM

(To be completed in duplicate)

Fee: 20,000/=

Serial no.:

FORM EA 1

PROPONENT: TANZANIA ELECTRICT SUPPLLY COMPANY LIMITED

PROJECT: Rehabilitation of Substations and Transmission Line Construction
Project in Kilimanjaro Region

Address for correspondence:

Tanzania Electric Supply Company
Strategic Planning and Projects
P.O. BOX 9024,
Dar-es-salaam.
Tanzania

Contact person:

Maneno Katyega (Senior Manager Strategic Planning)
Phone No: +255-22-2451206 Fax No: +255-22-2451206
Email: maneno.katyega@tanESCO.co.tz

ASSESSMENT No.:

File No.: _____

National Environment Management Council
P.O. BOX-63145
Dar-es-salaam,
Tanzania

Tel: +255-22-2127817/2134603

Fax: +255-22-2111579

NATIONAL ENVIRONMENT MANAGEMENT COUNCIL - NEMC

ENVIRONMENT IMPACT ASSESSMENT REGISTRATION FORM

1.0 PROPOSED UNDERTAKING/DEVELOPMENT

The proposed undertaking is named as “**Rehabilitation of Substations and Transmission Line Construction Project in Kilimanjaro Region**”

Introduction

Tanzania Electric Supply Company Limited (TANESCO) is a parastatal organization under the Ministry of Energy and Minerals (MEM) established in 1964. TANESCO is incorporated under the Companies Act (Cap 212).

The company's core business is Generation, Transmission and Marketing. TANESCO's generation system consist of mainly hydro (561MW) and gas thermal based generation (≥ 145 MW). It also purchases power from independent power producers SONGAS (189MW) and IPTL (100MW) making the total installed capacity in the Main Grid System to be 1051MW.

The transmission lines comprise of 2840 km of 220kV; 1617 km of 132kV; and 534 km of 66kV by the end of September 2009. The distribution system network supply voltage are 33kV and 11kV which serve as the backbone stepped down by distribution transformers to 400/230V for residential, commercial and industrial supply. The total network by November 2009 was 11,967km of 33kV; 5,063 km of 11kV and 25,381km of low voltage lines.

This project brief aims to provide enough information to environmental authority (NEMC) so as to screen the proposed project as per the Environmental Impact Assessment and Audit Regulations of 2005 requirements.

Current Situation of Transmission and Distribution System in Kilimanjaro Region

Transmission, substation and distribution system in Kilimanjaro has been used for 20 to 30 years and faces severe deterioration. Transformers at primary and secondary substation are almost overloaded and long distances of 33kV and 11kV distribution lines cause voltage drop. Rombo feeder for example which is the longest 33kV feeder from Boma Mbuluzi substation is extended up to 100km and once the feeder trips the whole feeder is forced to shut down without any switching device along the line.

The above mentioned situation causes low reliability and poor quality of power supply. This situation calls for urgent action to address the problems as soon as possible in order to vitalize economic activities, secure the quality of public services and improve social welfare in Kilimanjaro region.

Therefore, the main activities involved in this project will be the construction of new substations and transmission lines together with the rehabilitation of the existing substations in the Kilimanjaro Region. The works to be involved are as follows:

- Construction of the 66kV transmission line about 34Km from Kiyungi substation to Makuyuni-Himo.
- Construction of new 66/33kV Substations at Makuyuni
- Upgrading of 33/11kV Substations (Lawate, Machane, YMCA and Kiyungi) by increasing the capacity of transformers (e.g. at Kiyungi there will be the Installation of 20MVA/132/66kV transformer)
- Installation of 132kV incoming/outgoing bays at Same substation
- Construction of outgoing 33kV feeders at Makuyuni-56Km including the proposed Makuyuni-Mkuu Rombo feeder
- Construction of switching yard at Mkuu Rombo
- Construction of 33 kV line from Trade school to Gomberi
- Construction of new 33/11kV substations at KKCMC and Gomberi.

(Refer to Fig. 1)

Construction of 66kV transmission line

This will involve the 34km of construction between Kiyungi Substation and the new proposed Makuyuni substation. The transmission line will need at least a 10m way-leave corridor. Construction materials will be basically gravel, sand, cement and steel towers and aluminium alloy wire conductors. The design layout is as seen in **Figure 2**.

Apart from solid wastes such as pieces of conductors, wood, pieces of metals and household wastes to be generated during the construction period no wastes will be generated in the course of operation of the line.

There will be a number of people between 50 and 100 employed and casual labourers who will be doing various works during construction phase. It is envisaged that most of these jobs will be taken by Tanzanians except for some few highly skilled technical staff from Japan and other subcontracted companies.

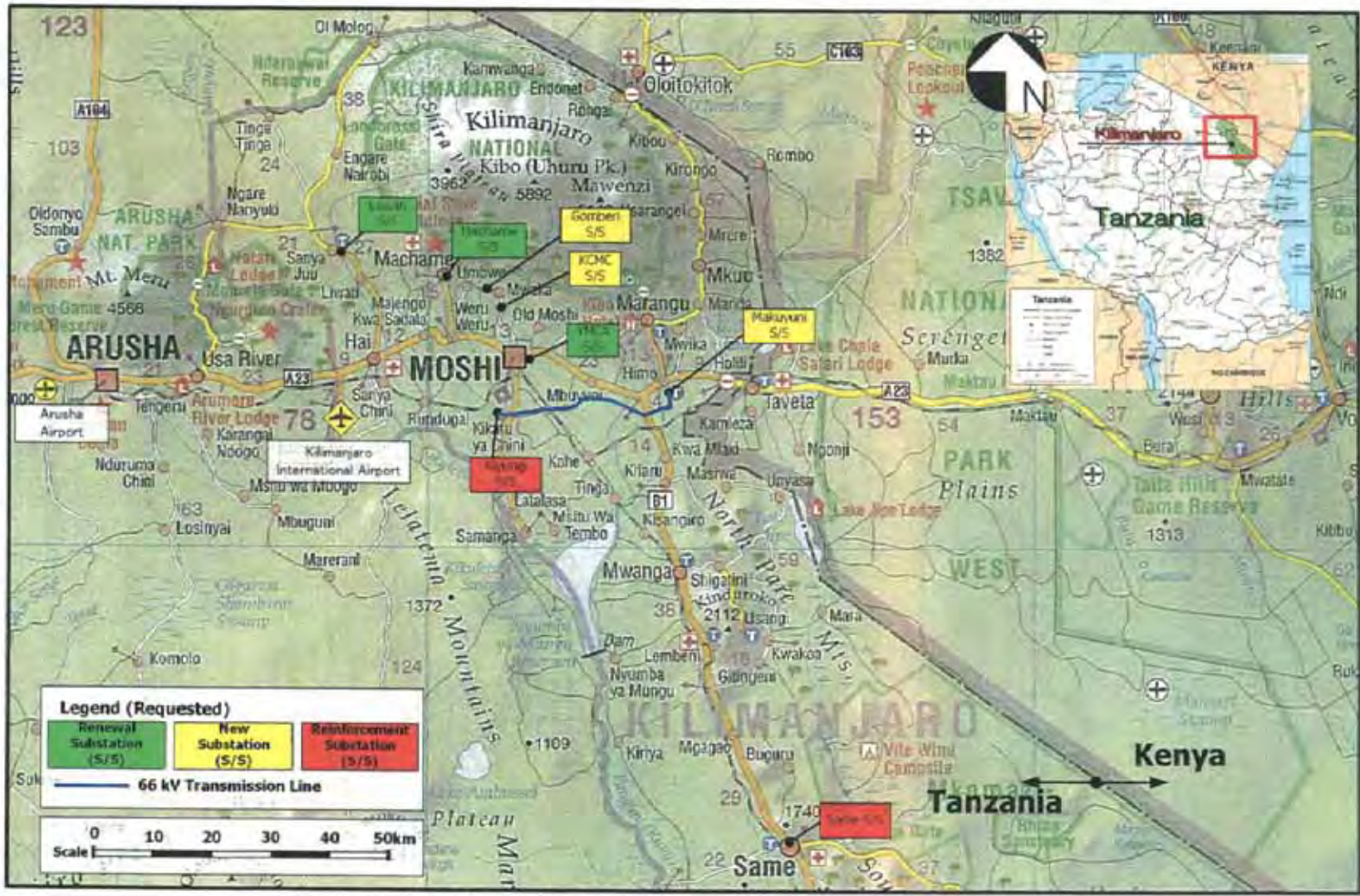

Required Project Site for Updating and Construction of Substations

Figure 1: Project Site

6. EIA登録申請書

During construction, a number of light and heavy duty vehicles will be used to carry out various duties including ferrying construction workers, construction materials, lifting loads and pulling conductors during stringing of the conductors. In addition, a bulldozer D6 or D8 will be used to clear a way leave before erection starts.

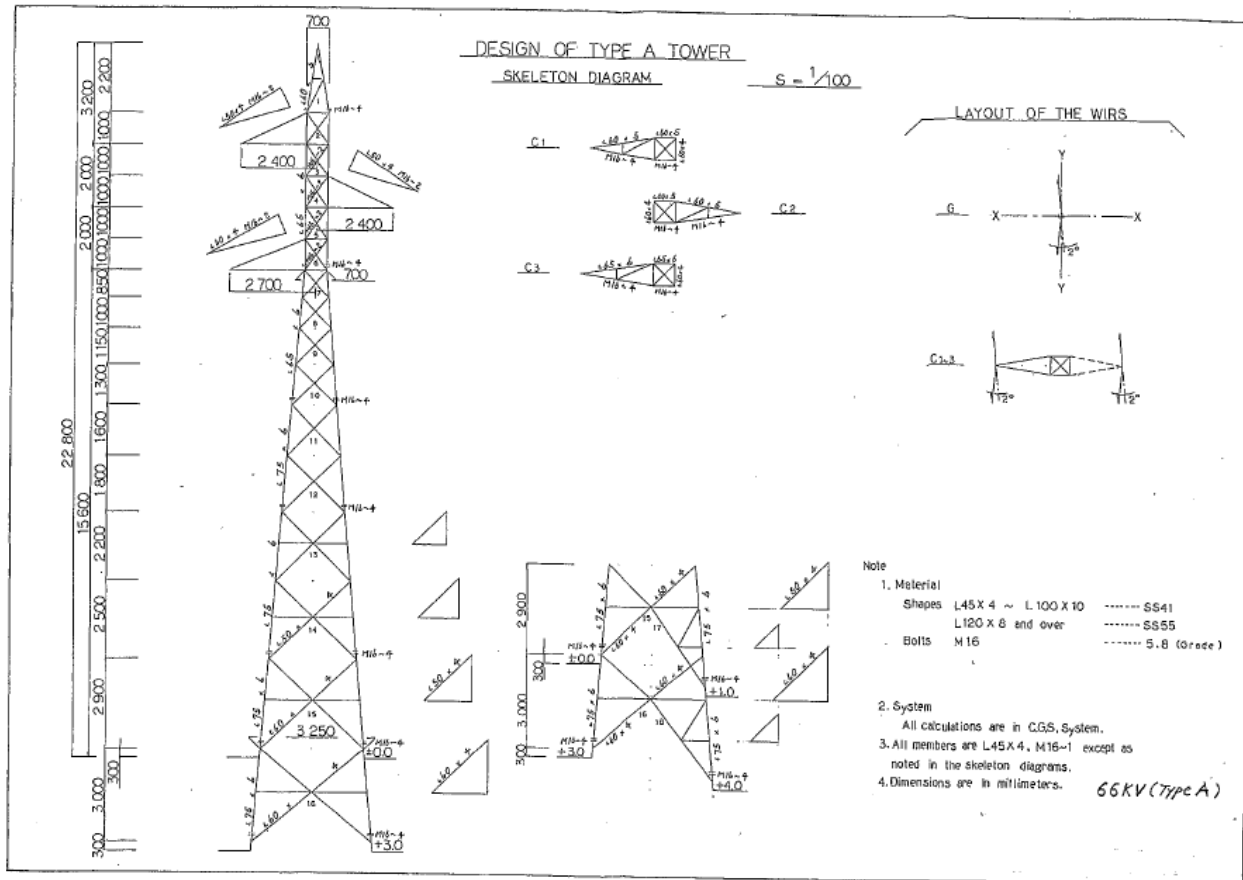

Figure 2: Proposed tentative Tower Design

Rehabilitation and upgrading of substations

The rehabilitation and upgrades of substations will involve changing the old transformers with new transformers with higher capacity as follows:

| S/N | Name of Substation | Capacity of the New Transformer | Remarks |
|-----|--------------------|---------------------------------|---------|
| 1 | YMCA | 15MVA/33/11kV | Upgrade |
| 2 | LAWATE | 10MVA/33/11kV | Upgrade |
| 3 | MACHAME | 10MVA/33/11kV | Upgrade |
| 4 | KIYUNGI | 20MVA/132/66kV | Upgrade |

6. EIA登録申請書

The upgrade will use the same existing substation site (refer **Figure 3**). Hence there will be no land take for upgrade of these substations. The work will involve simple excavations to erect the transformer foundations and installation of transformers with their accessories.

During construction solid wastes such as pieces of conductors, wood, pieces of metals and household wastes will be generated due to construction activities. Used transformers will be available for use in other areas. Old gravels will be re-used in the same substation. The new transformers will have the oil filled during manufacturing. No considerable wastes will be generated in the course of operation of the substation.

Rehabilitation of the substations will employ 10 to 15 people during rehabilitation peak time. This will include non-skill to highly skilled jobs working in various rehabilitation works. Depending on the job requirement, Tanzanians will be given priority to take those jobs.



Figure 3: Typical Example of Substation Arrangement and Rehabilitation Work

Construction of new Substations

| S/N | Name of Substation | Capacity of the New Transformer | Remarks |
|-----|--------------------|---------------------------------|----------------|
| 1 | KCMC | 10MVA | New Substation |
| 2 | GOMBERI | 10MVA | New Substation |
| 3 | MAKUYUNI | 20MVA/66/33kV | New Substation |

The construction of new substations will basically involve the installation of new transformers, protection system and a switch yard (refer **Figure 4**). It is expected that the substation will be outdoor type. The KCMC and Gomberi substations will be located in the land owned by KCMC and Gomberi farms respectively hence no land acquisition will be required for these substations.



Figure 4: Example of a 33/11kV Substation to be constructed

Land for locating the Makuyuni substation will have to be acquired from land owner. Processes for land acquisition are in advanced stage and the land owner is in the process of being compensated.

The proposed sites will undergo site clearance, levelling and compaction. Then foundation works for transformer seating, in-coming and outgoing feeder gantry

structures, switching installations etc. The substations will be enclosed for the safety reasons.

Construction materials will be gravel, sand, cement and iron bars, insulators, transformers, and conductors.

During construction it is anticipated that wastes such as pieces of conductors, wood, pieces of metals, broken insulators and household wastes will be generated. However during operation of the substation no wastes are expected.

There will be a number of people between 15 and 20 employed ranging from casual labourers to high skilled people who will be doing various works during construction phase. It is envisaged that most of these jobs will be taken by Tanzanians except for some few highly skilled technical staff who will come beyond the borders. During operation phase the substations will be remotely controlled and technicians will visit the substation for maintenance purposes. For Makuyuni substation at least 3 people will man the operation of the substation with an alternative of remote controlled option.

During construction, a number of light and heavy duty vehicles will be used to carry out various duties including ferrying construction workers, construction materials and lifting loads.

2.0 PROPOSED SITE

The proposed project is located in Kilimanjaro region. For the 66kV line, the 34km transmission will commence at existing Kiyungi substation close to Tanganyika Plantation Company (TPC). With a way leave corridor of at least 10m, the line will cross a sugarcane plantation following the existing access roads. Then the line passes through the agricultural fields and unpopulated areas of Mabogini, Rau River up to Makuyuni (Himo in Moshi Rural District). At Makuyuni a 66/33kV substation is to be constructed to feed all areas of Himo, Marangu together with Rombo districts. **(Refer to the attached 1:50,000 Overview Map).**

The land that will form part of the way leave is currently used for agriculture. At TPC the land is used for sugarcane plantation. At Mabogini the land is irrigated and they grow paddy, vegetables and beans. From Rau River to Mandaka mixed farming banana, paddy, beans and maize. From Kiruwa Vunjo to Kilatotoni again mixed farming of maize, beans, sunflowers, groundnuts and legumes (*Choroko*).

From Kilatotoni to Lotima there is a mixed farming, semi arid land and irrigated areas as one approaches Lotima village. The line has crossed in unpopulated areas. The **Photo Documentation (Attachment 1)** attached herewith depicts some of the features in pictorial views.

There will be improvement of distribution system at Mkuu Rombo through the construction of switching station which will receive a 33kV from Makuyuni Substation. The upgrade of lines will use the same existing lines only with change of conductors and insulators.

The new substations of KCMC and Gomberi will use the land owned by the institutions to feed power around Shanty town, KCMC, and Mweka areas. The land required for each 33/11kV substation is 30m by 40m and for the makuyuni 66/33kV substation the required land is at least 40m by 40m. The current land uses of these substation sites are open space for the KCMC and farmland for Gomberi and Makuyuni.

3.0 INFRASTRUCTURE AND UTILITIES

The proposed infrastructures are mainly transmission line and substations. Therefore, there will be steel towers, conductors, transformers, switchgears, insulators, protection devices and enclosures of the substation sites. While some items will be outdoor, others may be indoors particularly protection devices. As described earlier, the land size for substations and transmission line is 1200m², 1600m² and way-leave corridor of 10m for 34km respectively.

The installations will not use water apart from normal water uses during construction phase and domestic water uses at substations designed to be manned by people such as Makuyuni 66/33kV. During the operation no water will be used by the line or automated substation. Septic tanks and soak pit will be the only sewerage method to be used for sewage collection.

The substations will use own power from the grid system for internal lighting and security lighting. However for protection devices, external DC batteries will be used.

The construction of the 66kV transmission line will require an access road throughout the way-leave corridor during construction and maintenance purposes. However, new access road will be constructed only if there is no existing access

roads. All substations new and old have are accessible thus there will be no access road requirement.

4.0 ENVIRONMENTAL IMPACTS

Following the route survey and preliminary field trip conducted in May, there are various findings concerning Environmental (bio – physical) and Social impacts that were identified:

- The areas to be covered by the proposed line and Substations are mostly communal lands used mainly for agriculture. These lands will be acquired from the communities hence there will be a need for compensation in order to acquire the way-leave. Houses will be avoided as technically possible.
- The area proposed for construction is already disturbed by human activities, where it is currently used for cultivation purposes, as fallow land, pastures (grazing areas) and sugarcane plantations.

The proposed project will have the following impacts:

- Potential impacts related to land disturbance resulting from site clearing and construction of the line route for example soil erosion and mass wasting due to land degradation.
- Potential social impacts resulting from activities on the line route, presence of people on the site and health and safety impacts the construction of the line, access of way leave and other facilities. Examples may include:
 - Probability of new cases of HIV/AIDS, STDs infection caused by immigration of people to the project area,
 - social conflicts,
 - property theft
 - noises,
 - risk of fire and explosion.
 - Outbreak diseases like diarrhoea and cholera can also occur due to high concentration of people at the site.
 - Injuries to people can be a big safety concern caused by moving heavy machines and vehicles mainly during the construction phase.
 - unplanned pregnancies
 - disruption of norms and values of the given place due to interaction of new workers who will be working on the site are the likely impacts

- The most important negative social and economic impacts will be the removal of houses falling in the way leave. However, houses will be avoided as far as technically possible.
- Besides the negative impacts there will be potential positive impacts associated with this project ranging from individual benefits to national economy. Examples include:
 - Temporary employment to local individuals which will boost up the household income of the communities around the project area during the construction phase.
 - Self employments for small entrepreneurs in areas around the project for such work as supply of foods for construction workers and doing business with people working for the project.
- Taking the way-leave of 10m for 34km, the lost agricultural land is about 34 hectares. However, agricultural activities in the way-leave area are generally tolerated (but not formally allowed) as long as the height of plants does not exceed 3 m. The area lost for cultivation will be limited to floor-spaces needed for substations, tower foundations and access ways along the line. Hence the total loss of the land is reduced significantly after the construction activities and the way-leave corridor is used for cultivating short crops. In addition, the benefits the farmers will have from using access roads for their purposes may reduce or even over-compensate their losses of the land in the long term.

Further details on impacts are in **Attachment 2**

5.0 OTHER ENVIRONMENTAL ISSUES

The proposed project poses no significant risks or hazards to the environment. This type of project is common for TANESCO activities hence not new in our country. The only concern is a safety risk particularly electric shock and electrocution if there is no safety measures or there is negligence and if no precautions are not taken. TANESCO has in place safety policy which has been a backbone to safety especially when working with electricity. Therefore, safety measures will be in place to ensure safety of people, their properties and working personnel.

6.0 IMPACTS MITIGATION AND ENHANCEMENT MEASURES

TANESCO is committed to ensure that any significant impacts identified are mitigated within its capability. To ensure this TANESCO shall:

- Raise awareness of employees and local communities surrounding the project regarding protection of the environment, interaction with local environment, and health and safety issues (e.g. infectious diseases such as HIV/AIDS, STDs).
- In planning the detailed routing of access roads and other infrastructures to avoid built up areas and clearance of ecologically sensitive vegetation species that may exist.
- Ensure daily environmental and safety management best practices for minimizing and prevention of accidents and hazardous materials as well as soil erosion controls.
- Put in place measures to deal with emergencies (fire, accidents, etc)
- Make a provision for monitoring the implementation of mitigation measures during construction.

Further details on mitigation measures and implementation of environmental and social management plan are obtained in **Attachment 2**.

DECLARATION

I.....hereby declared that the information provided on this form is true to the best of my knowledge and I shall provide any additional information that shall come to my notice in the course of the processing of this application.

.....
Signature

.....
Date

PHOTO DOCUMENTATION



PLATE 1: Vegetation covers at the proposed 66kv transmission line in the yamuMkaa Village.



PLATE 2: This is an area where the proposed MkuuRombo Substation will be built



PLATE 3: A section of Mabogini people who attended a consultative meeting for the proposed 66kV line is listening to their fellow resident giving his views about the project.



PLATE 4: Meeting with Stakeholders at Mabogini

Attachment 1



PLATE 5: Environmental Degradation (severe soil erosion) in Yamu Mkaa



PLATE 6: Grazing animals is one of activity in the project area here is at Yamu Mkuu



PLATE 7: This is Mabogini area where the line will cross the railway line and go straight ahead



Plate 8: This is the area where the proposed Makuyuni Substation will be built.



Plate 9: A section of Sugarcane plantation at Kiyungi where the proposed transmission line will follow at the edge of this access road



Plate 10: A proposed site for KCMC Substation



Plate 11: Vegetation Cover and physical features at Kilatotoni overlooking Makuyuni Direction



Plate 12: Vegetation Cover and physical features at Kilatotoni overlooking Kiyungi

Attachment 1

CONCERNS FROM STAKEHOLDERS:

In a preliminary public consultation survey conducted for this project, the stakeholders had the following concerns and opinions:

1. The first speaker started by thanking the TANESCO for involving the affected people from the very beginning of the project. The speaker wanted TANESCO to know is that if 20m wide corridor will be taken from their land particularly paddy farms (*boda*) they will be very much affected by the project because they depend on those paddy farms for their livelihood. Hence he believes that the project will cause them great harm psychologically and particularly children since the land is becoming smaller and smaller in size.
2. Employment should be offered to the village residents first in all villages through which the proposed transmission line passes.
3. The compensation to be fair and promptly.
4. Use of land under the transmission line for the agriculture activities should be allowed. (i.e. restrictions on land use should be eased)
5. We want to know clearly the actual area where the proposed transmission line passes to be sure of people who will be affected by the project.
6. There must an open communication to all affected people to avoid the misunderstanding about the project.
7. They wanted to know what will be the benefit of the Project to the people surrounding the project area.
8. They would like to be involved in every process of the project.
9. Most of the people likely to be affected by the project wanted to be allocated a new plot in the very neighbourhood since the compensation money will not be sufficient to buy the same land.

Attachment 1

10. People would like TANESCO to compensate them satisfactorily to the point that they will be able to live comfortably as they are currently living there.
11. TANESCO should try to look for a place to divert the line where people to be affected will be fewer.
12. People living close to the transmission lines want assurance of their safety from the electricity emissions if any.
13. People wanted to know compensation modality and how is it going to be implemented. Also wanted to know what is going to be compensated.