

Source: JICA Study Team

Annex-F H.2.3.7 Location of Proposed Balog-Balog Storage Dam

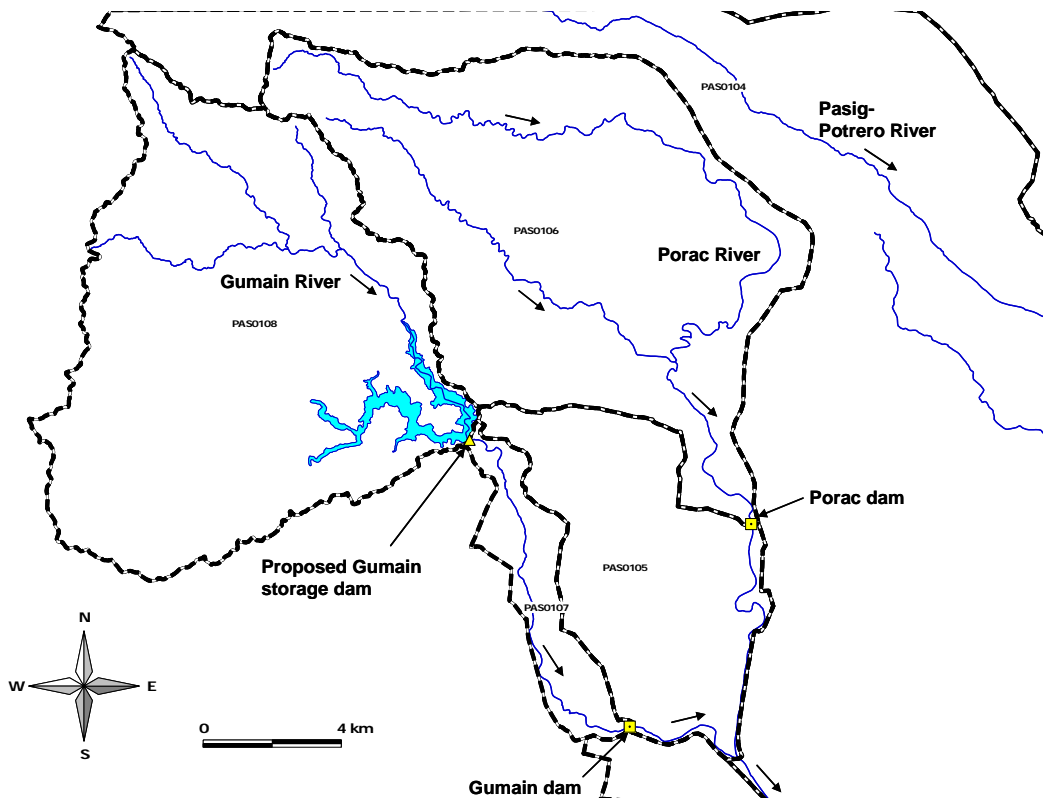

Source: JICA Study Team

Annex-F H.2.3.8 Location of Proposed Gumain Storage Dam

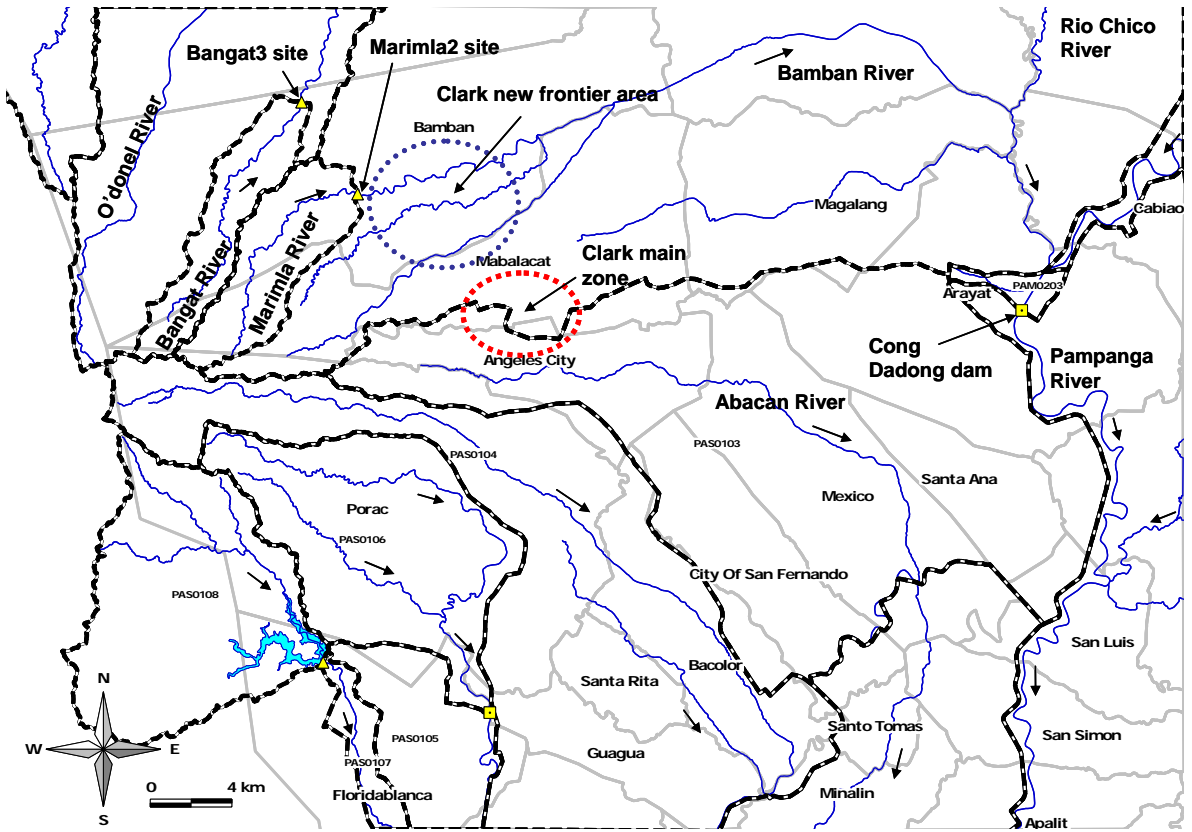

Source: JICA Study Team

Annex-F H.2.3.9 Location of Marimla2 and Bangat3 Sites

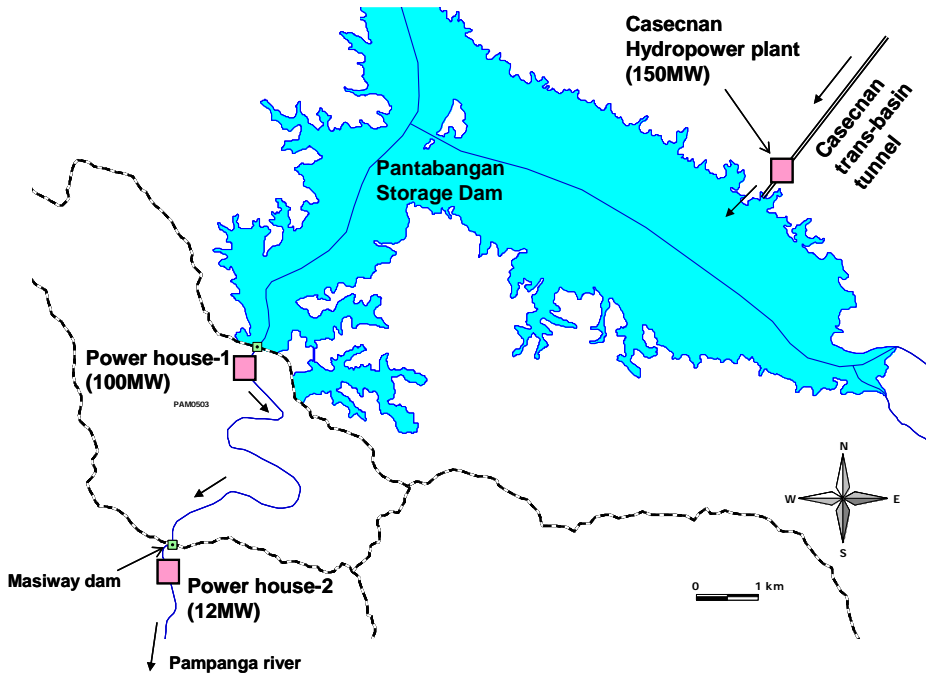
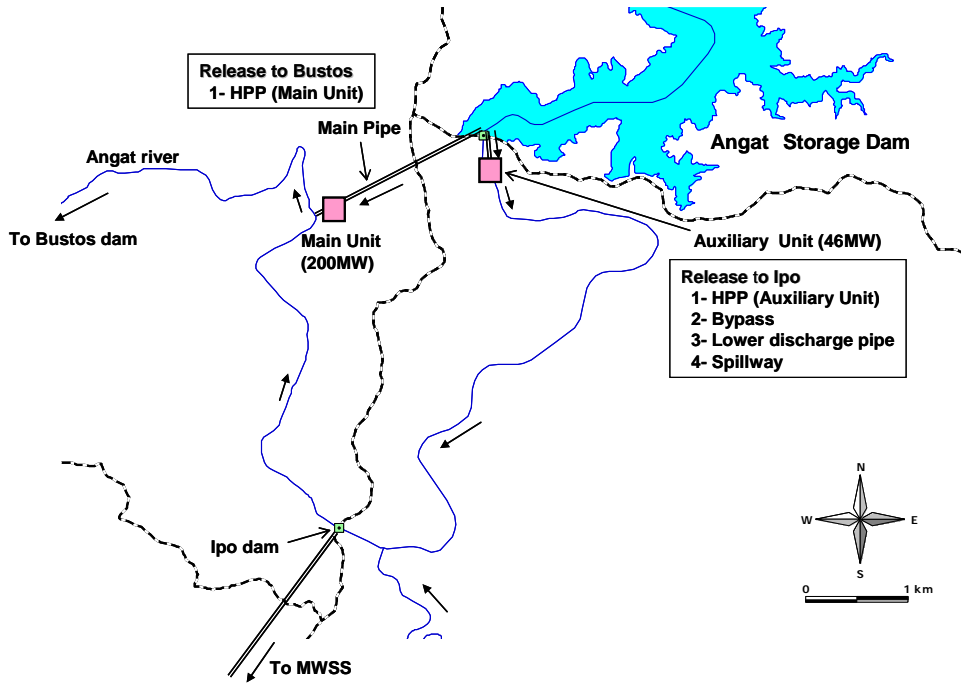

Source: JICA Study Team

Annex-F H.2.4.1 Existing Hydropower Plants in the Study Area

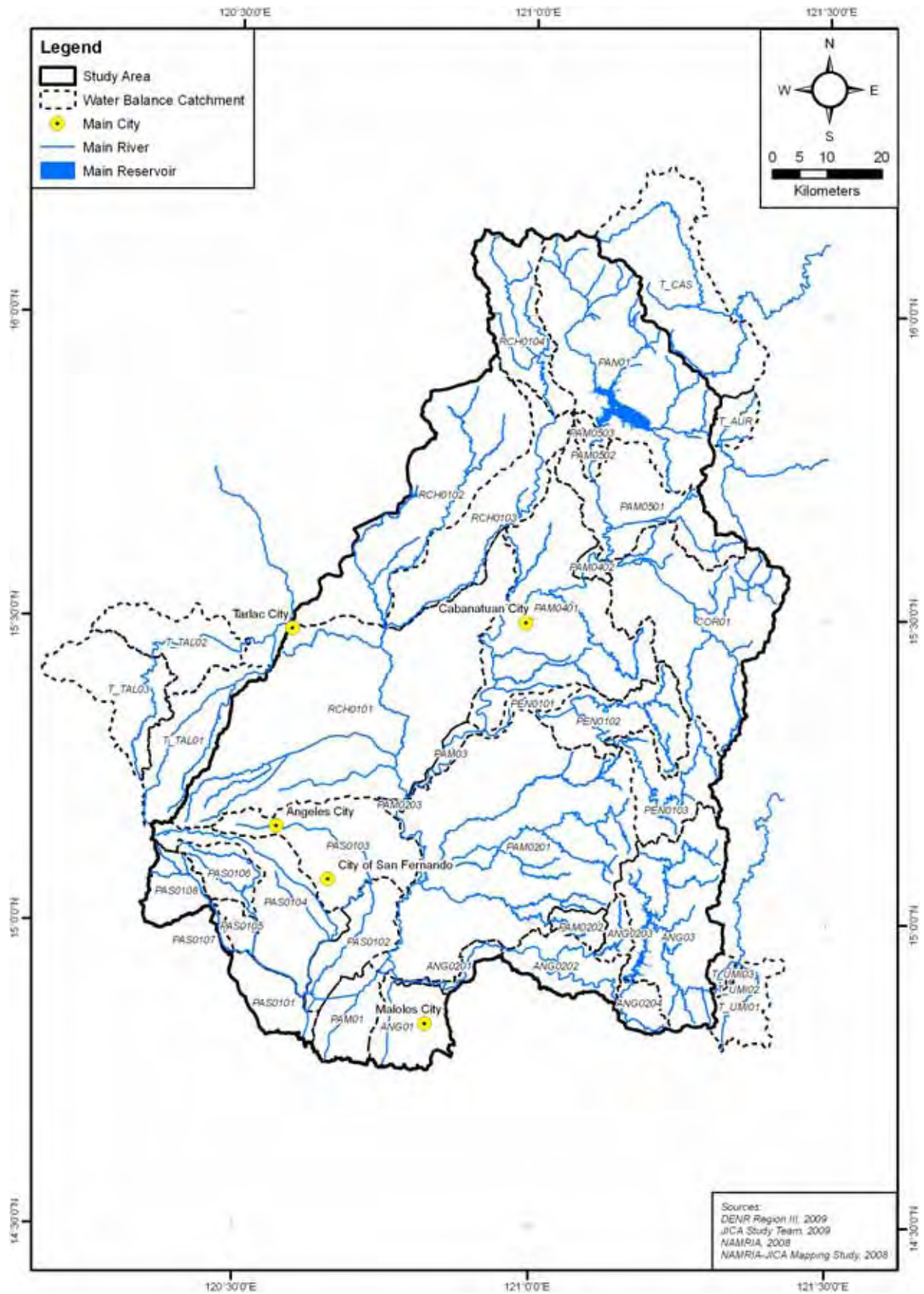

Annex-F H.3.1.1 Water Balance Catchments

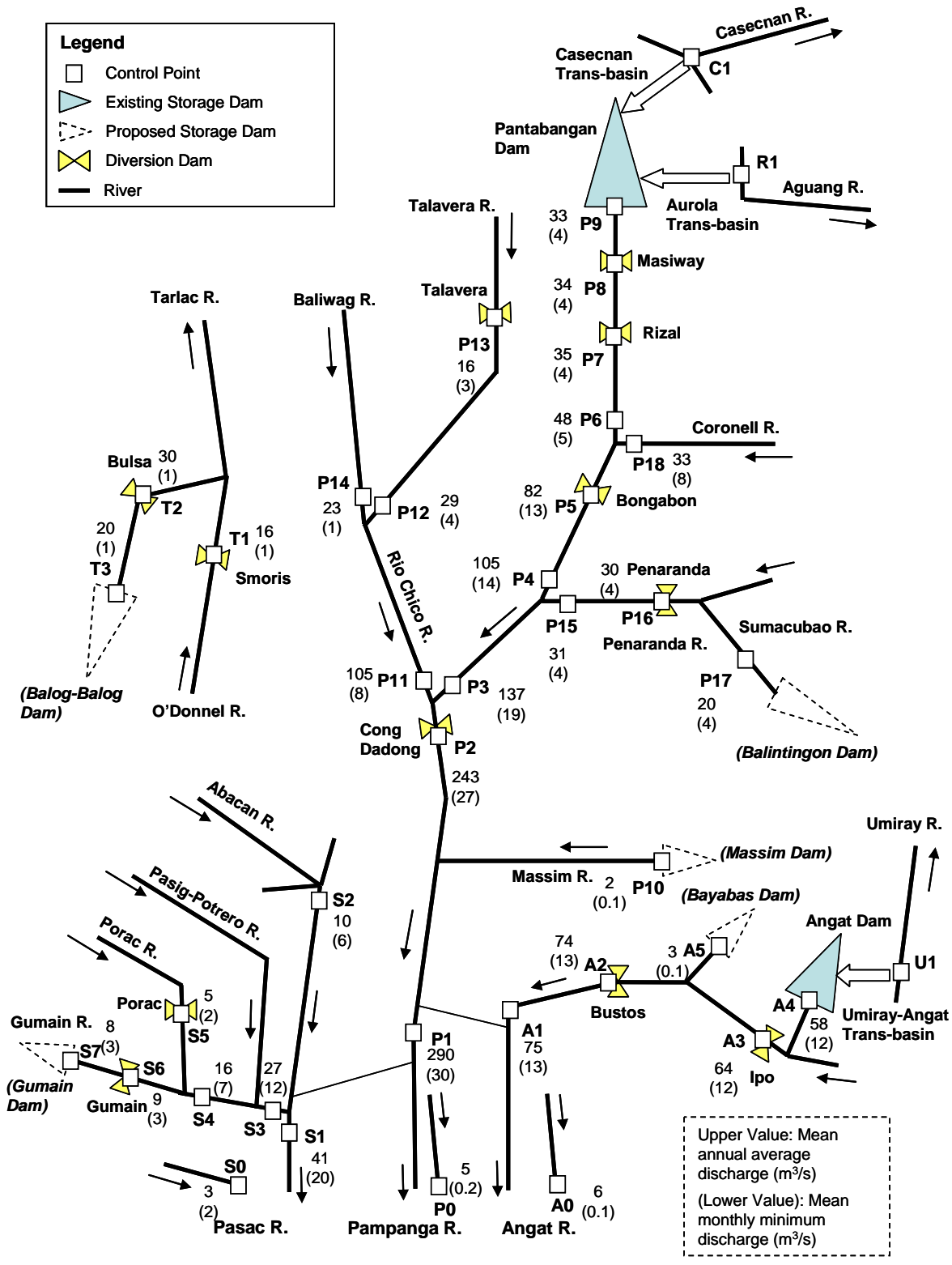

Source: JICA Study Team

Annex-F H.3.1.2 Control Points and Discharge in Quasi-Natural Flow Condition

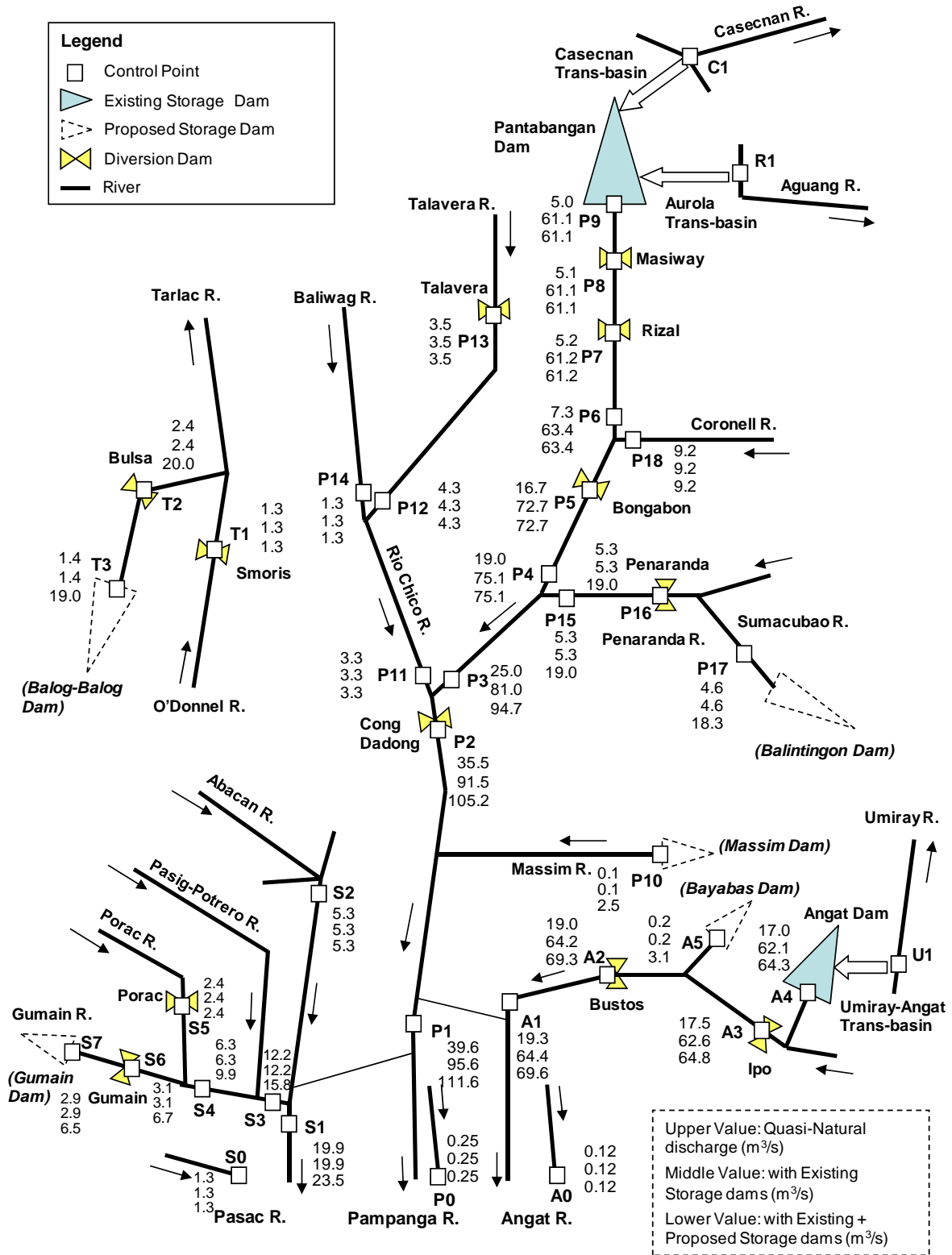

Source: JICA Study Team

Annex-F H.3.1.3 Surface Water Resources Potential (Equivalent to 80% Reliability)  
with Existing and Proposed Storage Dams at Control Points

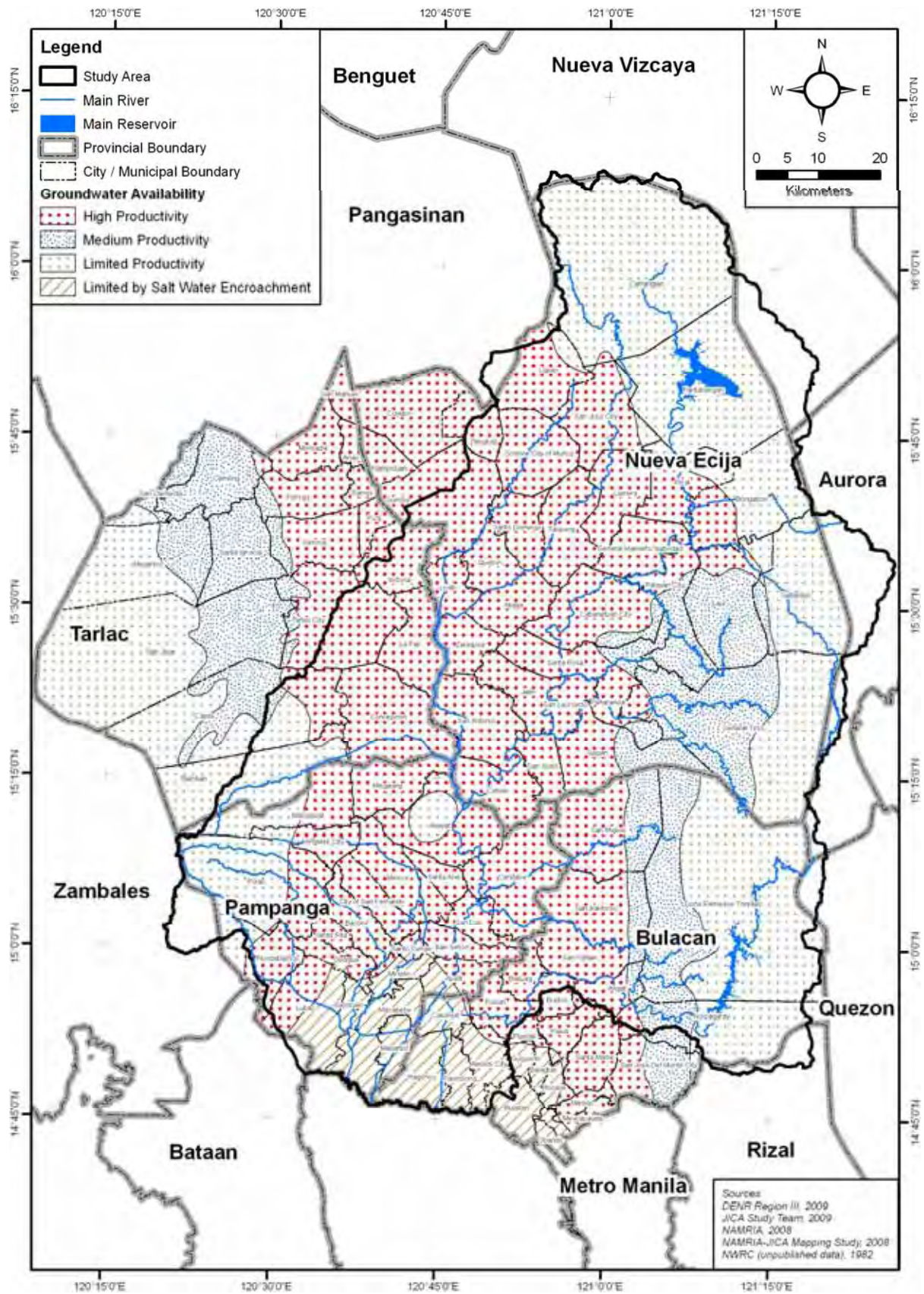

Annex-F H.3.1.4 Sub-Areas for Groundwater Availability in the Provinces of Bulacan, Pampanga, Nueva Ecija and Tarlac

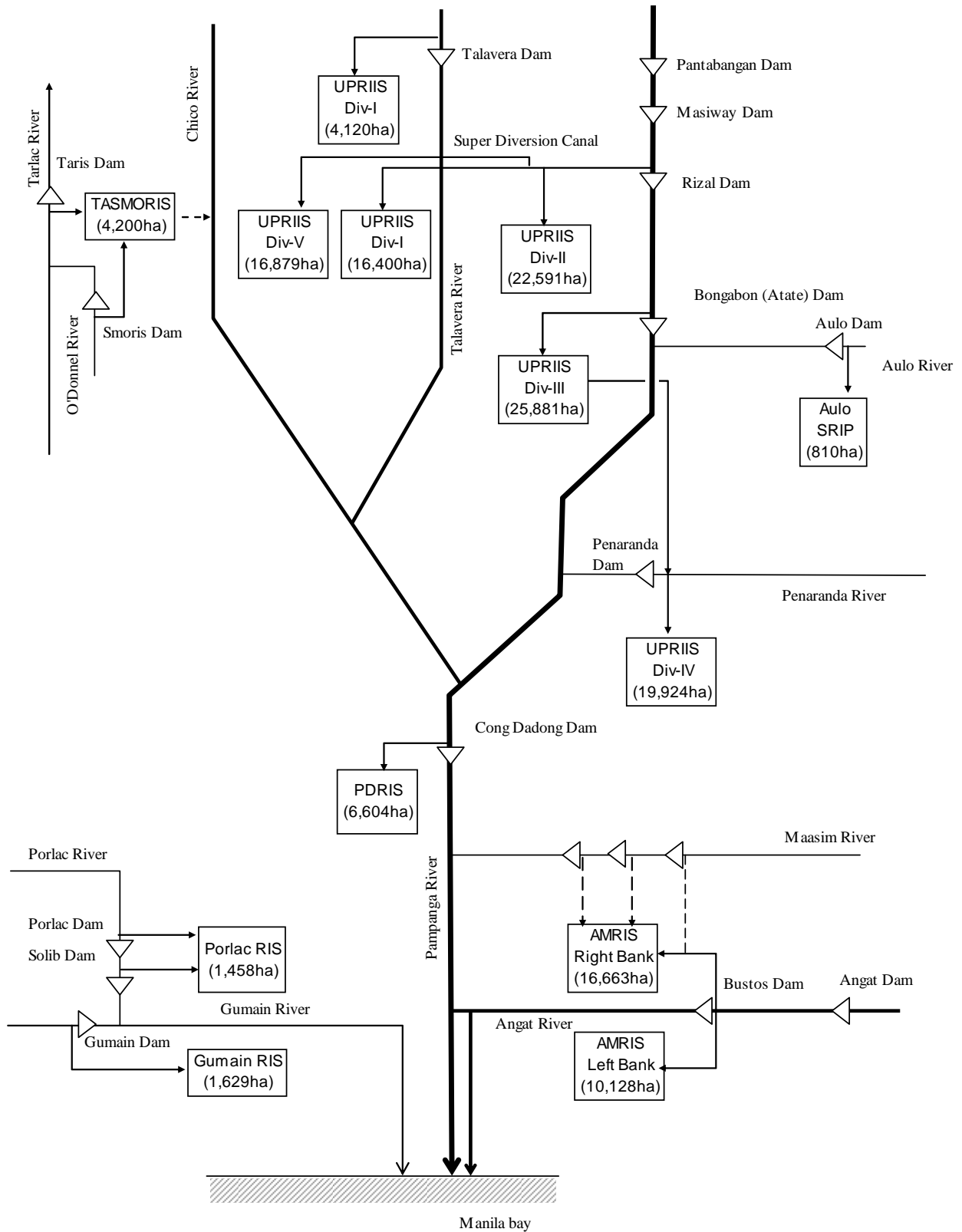

Source : JICA Study Team

Annex-F H.3.2.1 Schematic Flow Diagram of Existing NIS



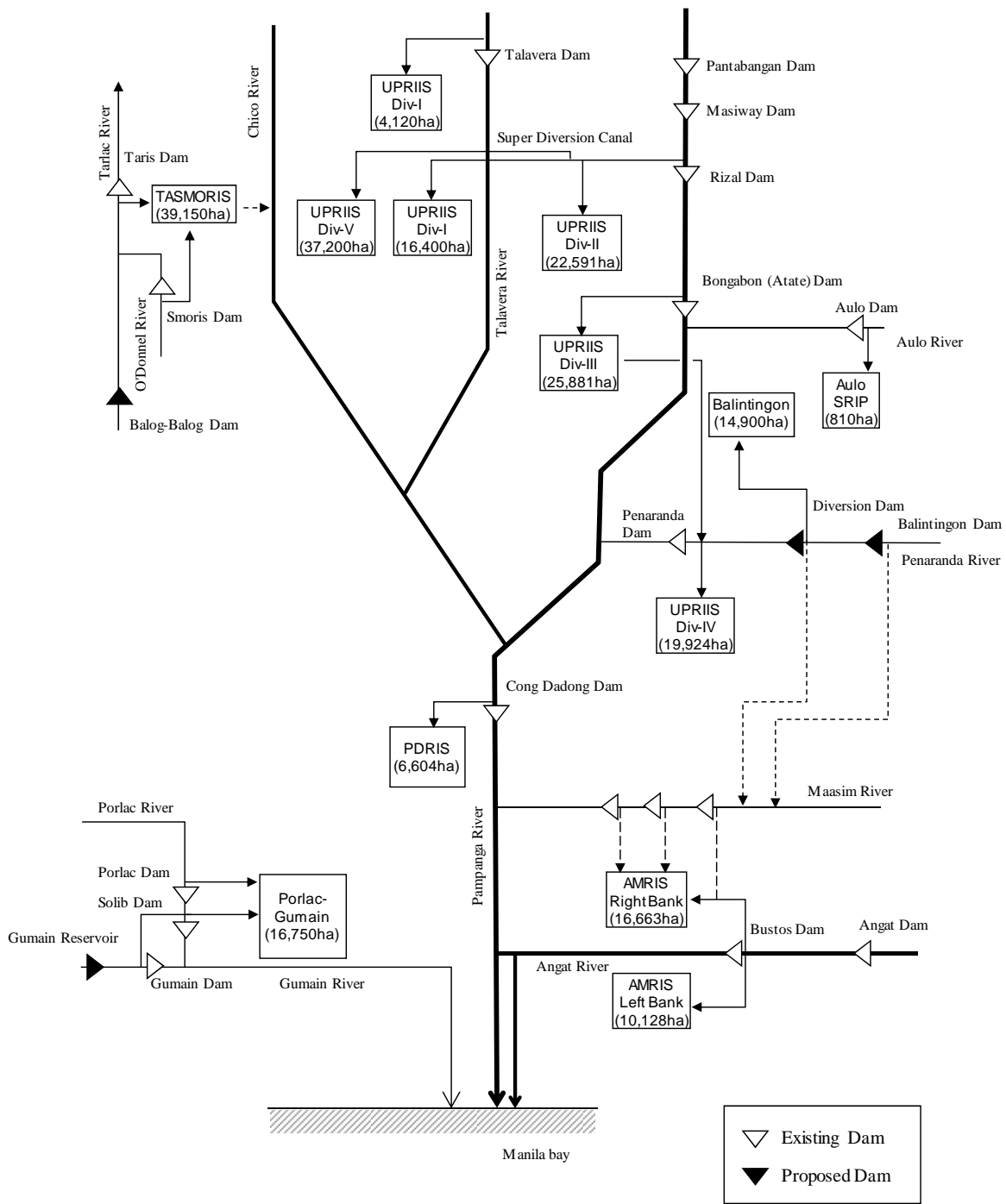

Source : JICA Study Team

Annex-F H.3.2.2 Schematic Flow Diagram of Projected NIS

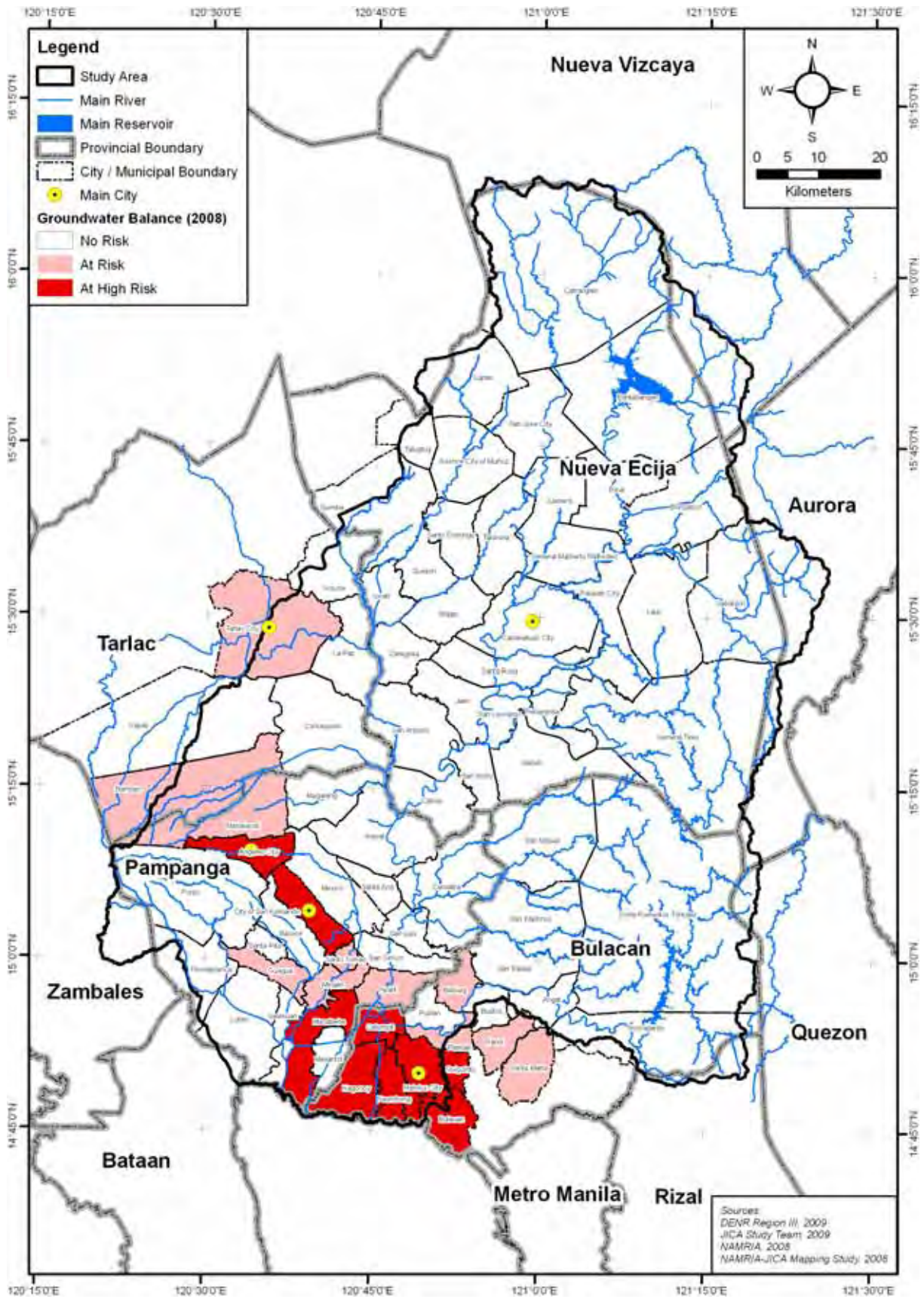

Annex-F H.3.3.1 Evaluation of Groundwater Usage Condition in Present Condition (2008)

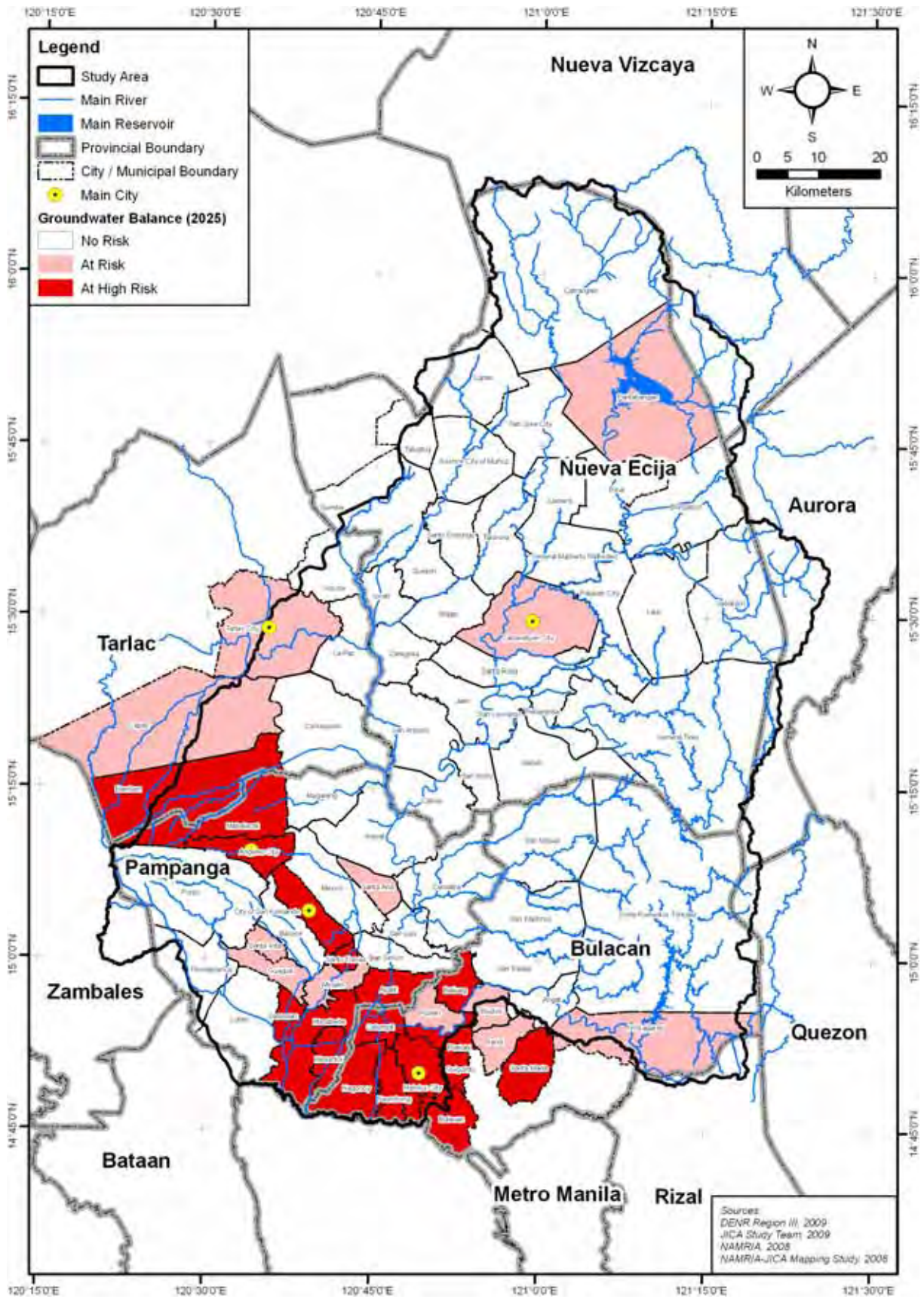

Annex-F H.3.3.2 Evaluation of Groundwater Usage Condition in Future Condition (2025)

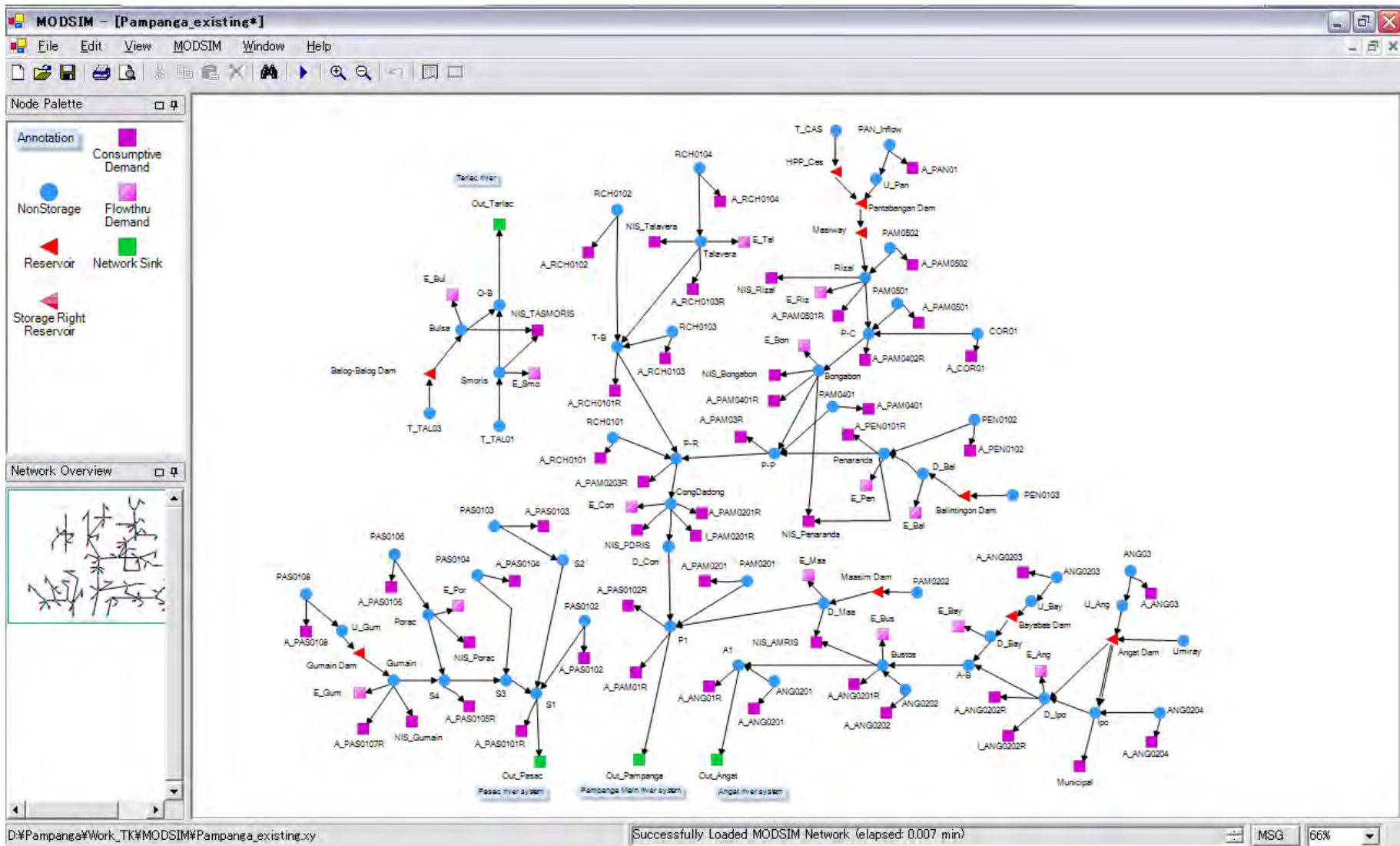

Source: JICA Study Team

Annex-F H.3.3.3 MODSIM Model Setup for Water Balance Simulation for Present Condition (2008)

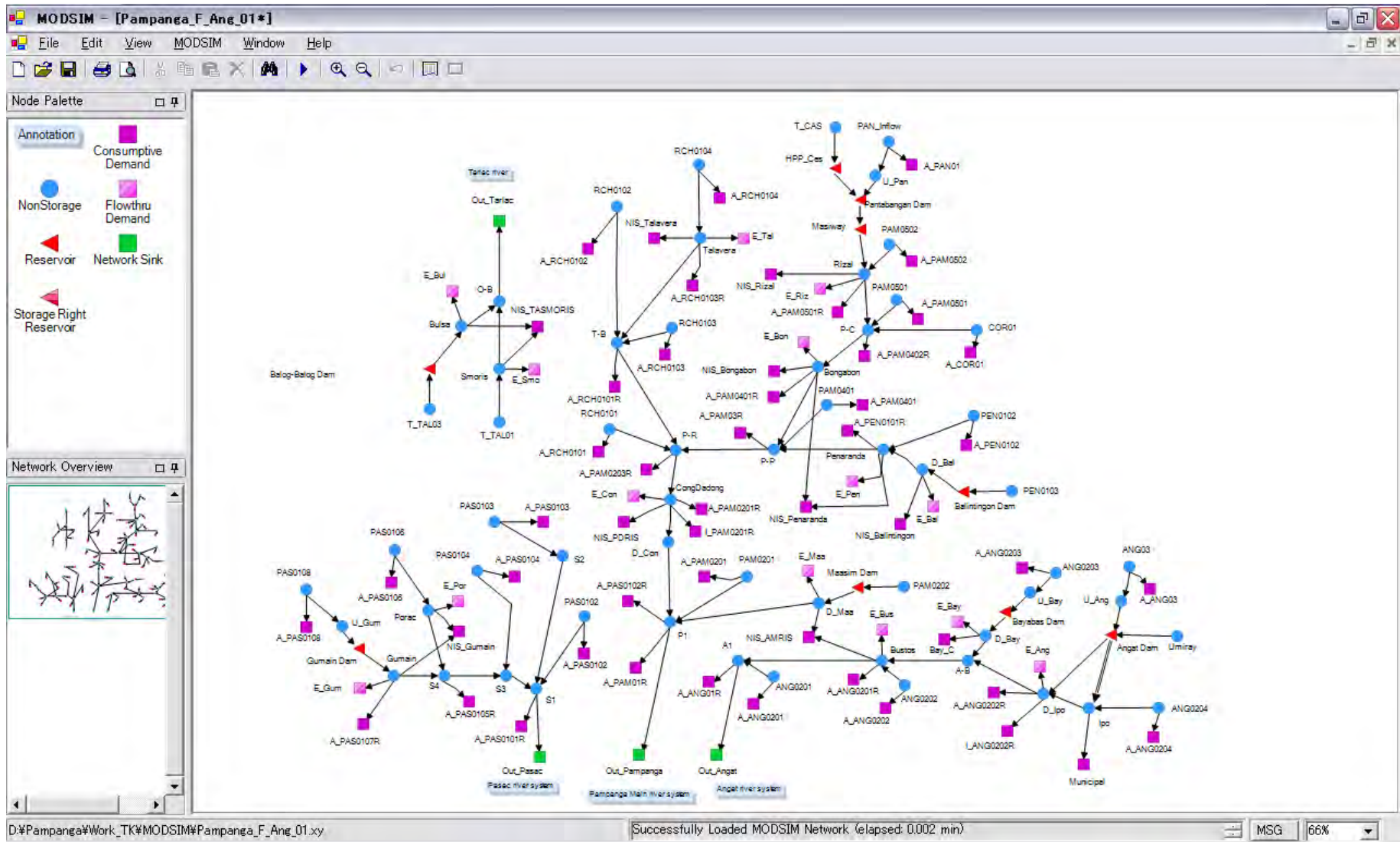

Source: JICA Study Team

Annex-F H.3.3.4 MODSIM Model Setup for Water Balance Simulation for Future Condition (2025)

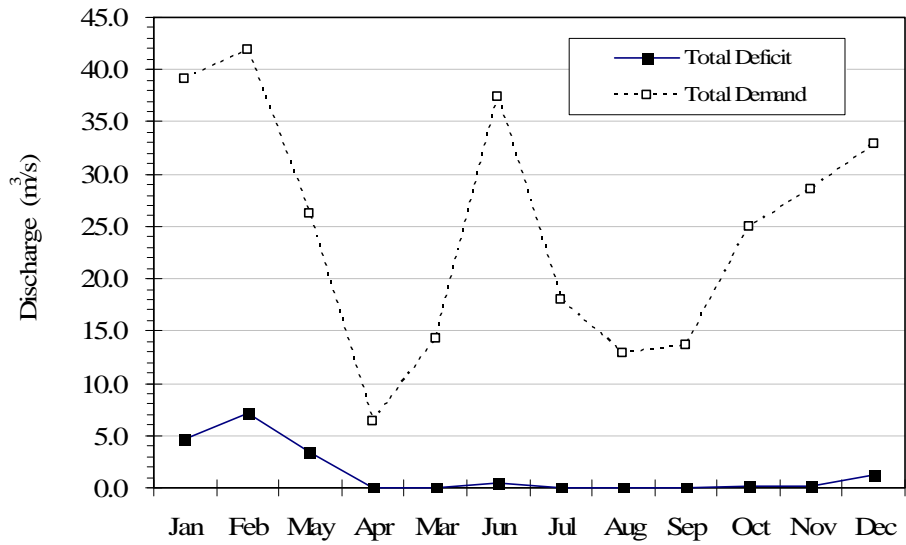

Source: JICA Study Team

Annex-F H.3.3.5 Total Demand and Average Total Deficit for CISs and Other Agricultural Water Use such as Fresh Water Aquaculture in Present Condition

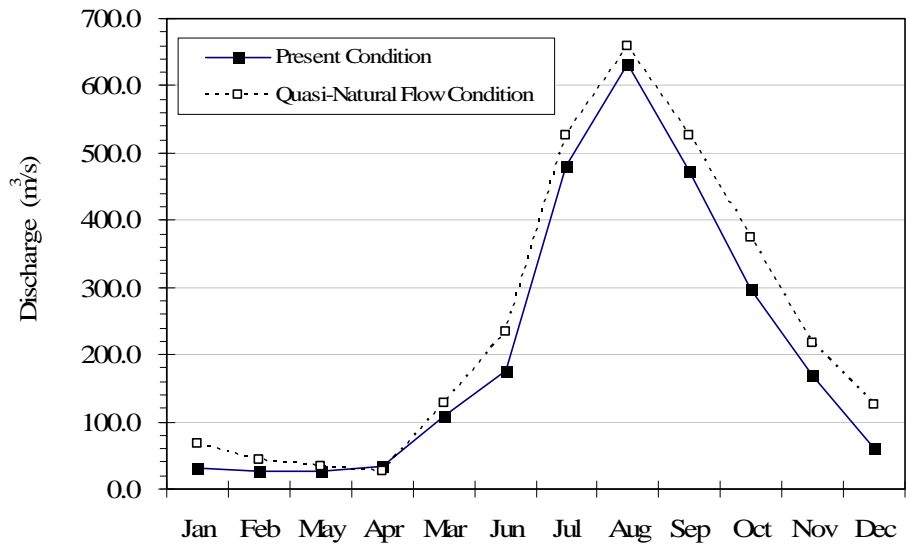

Source: JICA Study Team

Annex-F H.3.3.6 Simulated Average Monthly Flow Pattern in Present Condition and Quasi-Natural Condition at around the Intake of Cong Dadong dam in the Pampanga River

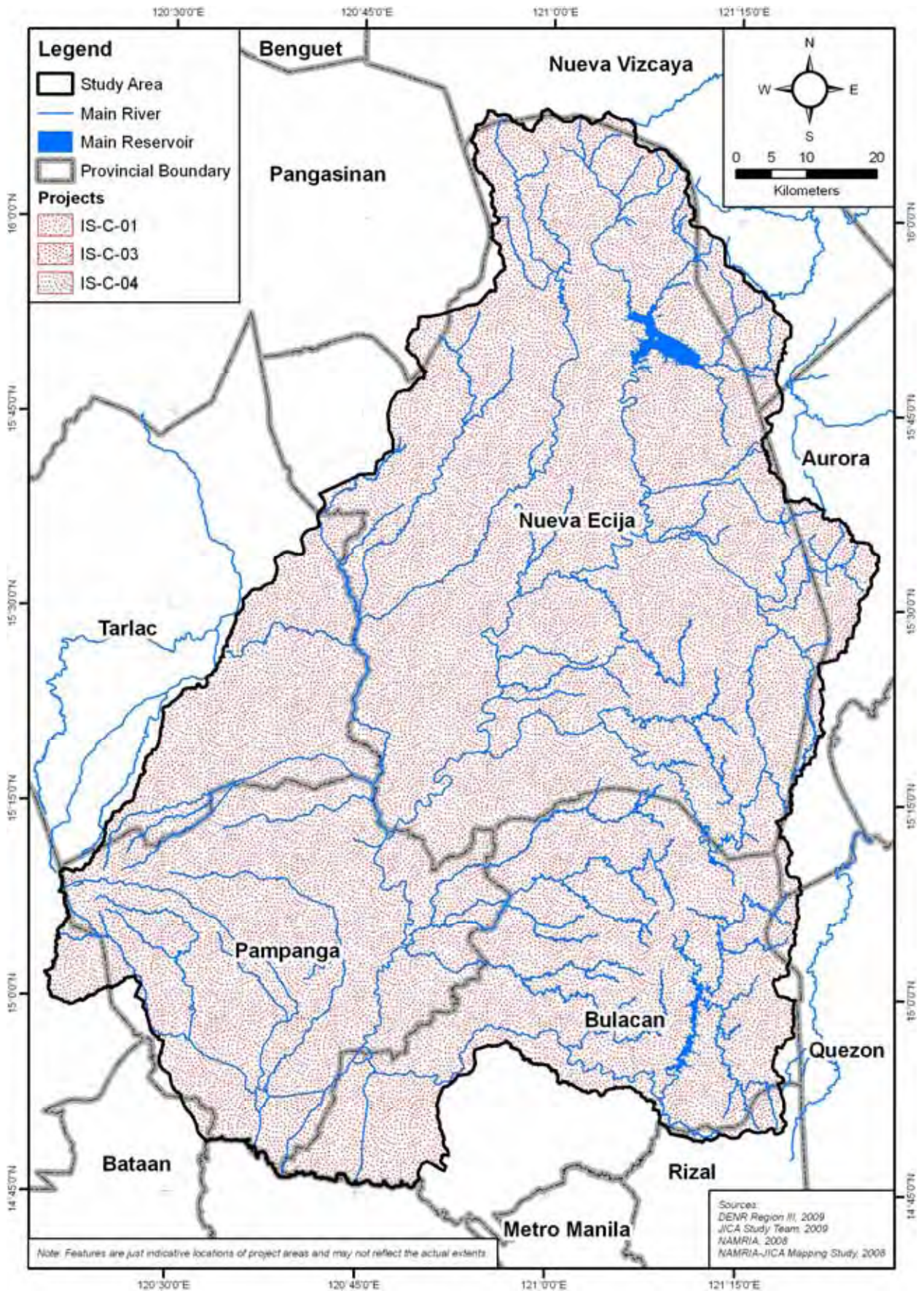

Annex-F H.4.2.1(1/2) Location of Projects in Water Resources Development, Allocation and Distribution

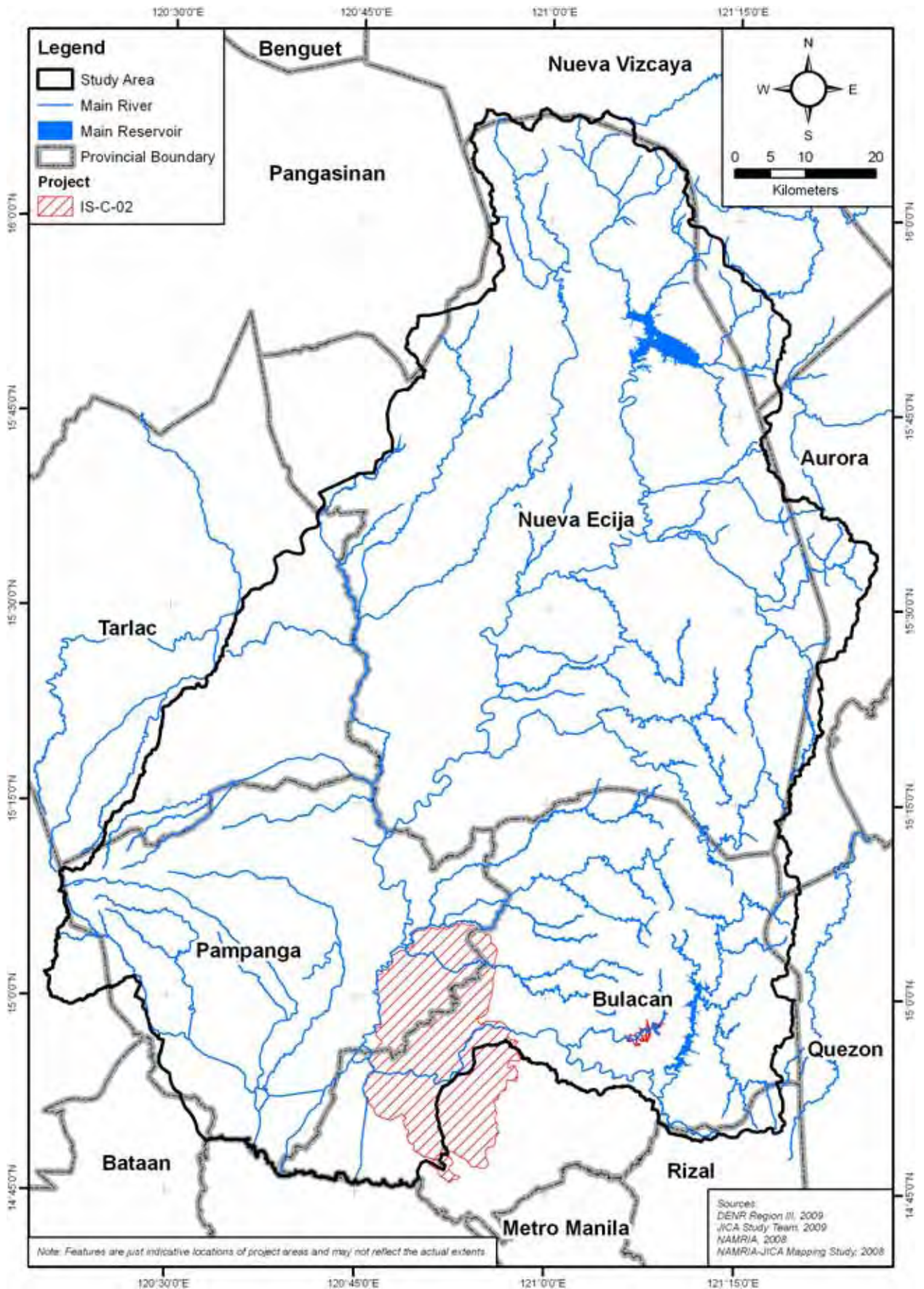

Annex-F H.4.2.1(2/2) Location of Projects in Water Resources Development, Allocation and Distribution



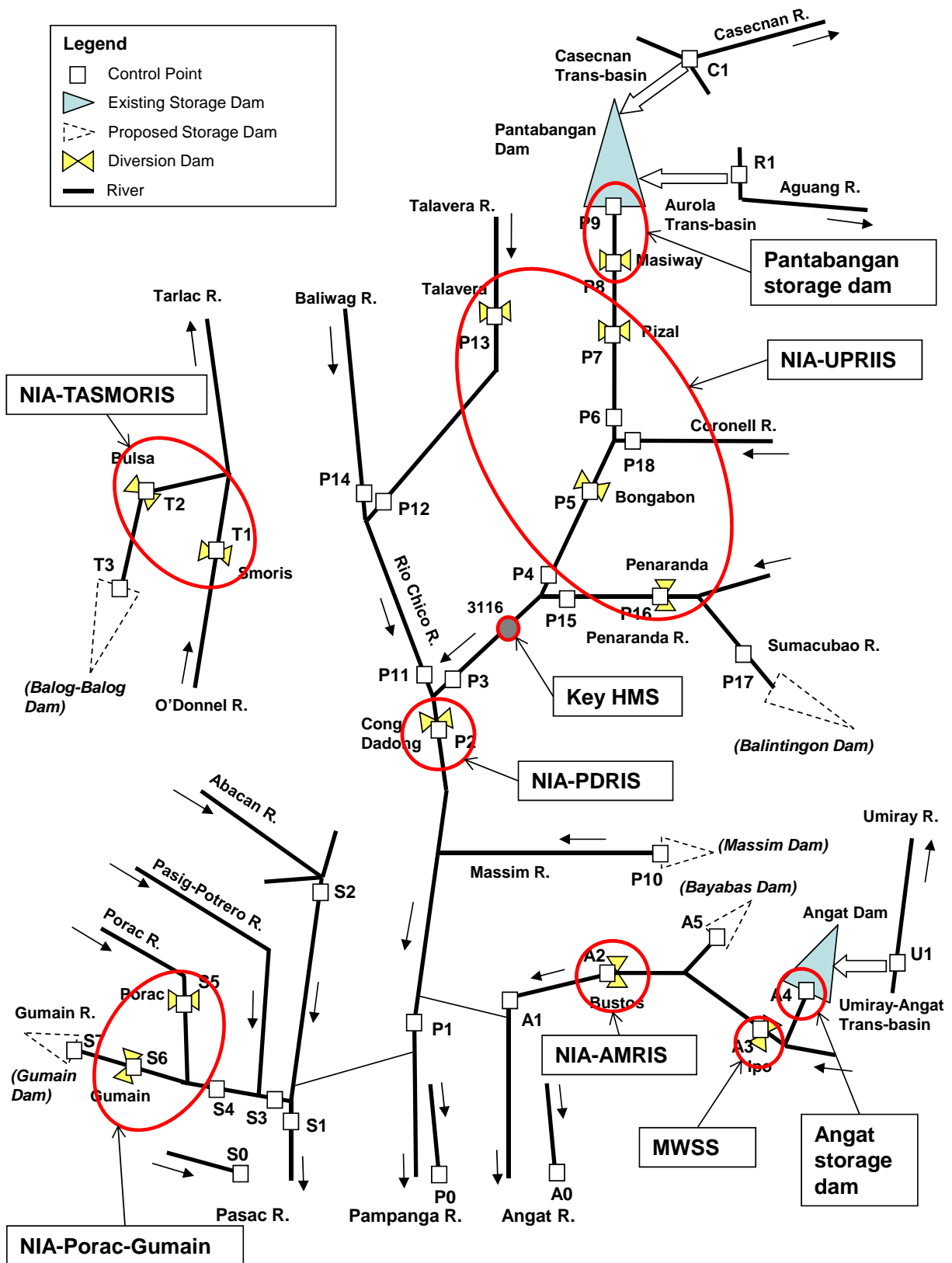

Source: JICA Study Team

Annex-F H.4.3.1 Tentatively Proposed Monitoring Stations for Surface Water