

Attachment 1-4

Minutes of Meeting (3rd Steering Committee)

&

Discussion materials

MOM
OF
PROJECT STEERING COMMITTEE
ON
FEASIBILITY STUDY
FOR
ENHANCED WATER SUPPLY SYSTEM PROJECT

DATE: June 7, 2010

PLACE: Praia, Cape Verde

1. The Government of the Republic of Cape Verde (GoCV), in cooperation with the Government of Japan, intends to develop a structuring and strategic water sector project on the island of Santiago, aiming both at improving the water supply conditions, through the interconnection of water transmission and distribution networks, and at strengthening the production capacities;
2. Given the specific and strategic significance of the project, a diligent and efficient technical follow-up will be needed for the same ;
3. In the scope of implementation of the above mentioned project, there will be a need to guarantee, to the GoCV, reliable technical counsel and assistance;
4. It is much advisable that the project be followed up and supported by all sectors and institutions which are, in one or other way, related to the water sector.
5. In this purpose, a Project Steering Committee has been officially established on 26th of January 2010 by the DISPATCH No. 007 / 2010 issued by MEGC (now MTIE).
6. The Project Steering Committee has met officially for the third time on the 7th of June 2010, in the office of Cape Verde Investment Agency, Praia, Cape Verde. The list of participants is given in ANNEX-2.
7. The main points discussed are based on the presentation by The JICA study team of all results and propositions related to the project at the time of the meeting. This presentation is given in ANNEX-1.
8. The Project Steering Committee members hereby confirmed full understanding of main points discussed as per hereto the Attachment of the Minutes of Meeting.

By Chairman of the Project Steering Committee

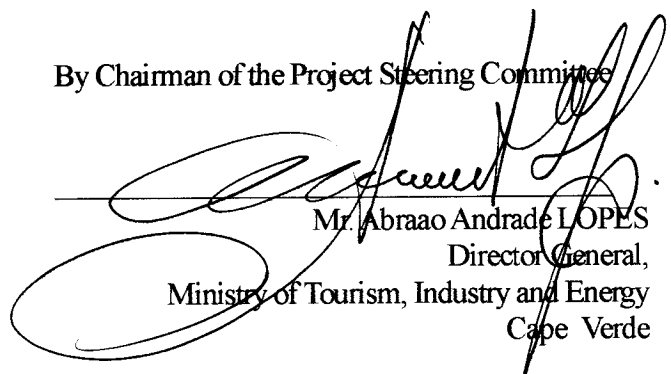
Mr. Abraao Andrade LOPES
Director General,
Ministry of Tourism, Industry and Energy
Cape Verde

ms

MINUTES OF MEETING
ON
DESIGN CONDITION DEFINITION
FOR
THE PREPARATORY SURVEY
ON
WATER SUPPLY SYSTEM DEVELOPMENT PROJECT
IN
THE REPUBLIC OF CAPE VERDE

Praia, June 7, 2010

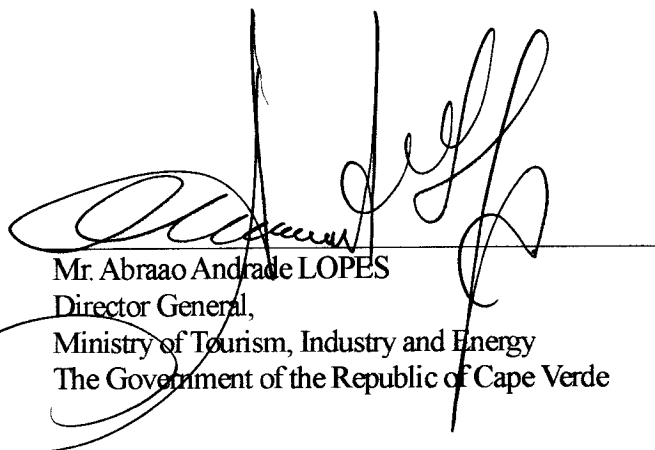

Mr. Abraao Andrade LOPES
Director General,
Ministry of Tourism, Industry and Energy
The Government of the Republic of Cape Verde

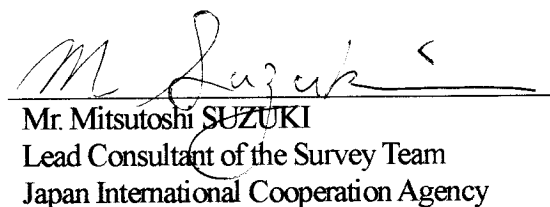

Mr. Mitsutoshi SUZUKI
Lead Consultant of the Survey Team
Japan International Cooperation Agency

Attachment

Japan International Cooperation Agency (hereinafter referred to as "JICA") dispatched a mission (hereinafter referred to as "the JICA Mission") to the Republic of Cape Verde. Since its arrival on May 17th, 2010, the JICA Mission and officials of Government of the Republic of Cape Verde (hereinafter referred to as "the GoCV"), Ministry of Tourism, Industry and Energy, (hereinafter referred to as "MTIE") had detailed discussions on the Progress Report of the Preparatory Survey (hereinafter referred to as "the Survey") for Water Supply System Development Project (hereinafter referred to as "the Project").

In the course of discussions, both sides confirmed the main items described below. The JICA Mission will proceed as planned up to December 2010, when the Survey comes to the end.

1. Conditions of the Survey in general

The JICA Survey Team stated that the results of discussions do not imply any decision or commitment by JICA for its prospective loan for the Project at this moment and the above results should be reported to the higher authority of JICA and the Government of Japan.

2. Major Points Discussed

(Activities of other donors and firms)

(1) As for the activities of other donors and firms the GoCV explained and confirmed the below.

- a. The Survey shall include financial cooperation of Spain (5,000m³/day) and of World Bank (5,000m³/day) to expand the existing desalination plant at Palmarejo in Praia.
- b. The concession contract between GoCV and CAIS is still under discussion. Therefore, the Survey does not need to include CAIS projects to construct desalination plants in Sao Miguel and Santa Cruz.
- c. The Survey shall take note of the construction plan of water transmission line from Calheta de Sao Miguel to Assomada, which was already planned by GoCV.

(Outcomes of the 3rd mission by JICA Survey Team and Design Framework)

(2) As for the Survey conducted by during the 3rd mission, JICA Survey Team explained and all the participants of Steering Committee accepted the below.

- a. JICA Survey Team has conducted the actual Survey based on the option proposed by the internal steering committee held on April 28th and the discussion and result of the 2nd Steering Committee held on May 21st, 2010.
- b. JICA Survey Team reached the conclusion of the most optimal solution through development of survey including cost analysis, which is to produce desalinated water by 2 major plants located within the premises of ELECTRA at Palmarejo and at the proposed site of Calheta de Sao Miguel, each of them having a production capacity of 20,000 m³/day of desalinated water at Horizon 2020, and to transport produced desalinated water with inter-municipality transmission network.
- c. JICA survey team has presented the revised prospective evaluation of water demand in 2020. The JICA Survey Team has actualized the data through the meeting with concerned authorities and institutions of GoCV such as MTIE, INE, INGRH, ELECTRA, etc. for the basic plan and feasibility study.



- d. All participants of the present Steering Committee explained their opinion concerning the revised prospective evaluation of water demand, whose subjects are mainly, 1) household connection ratio target in 2020, 2) leakage ratio target in 2020 of their municipalities in order to finalize the prospective evaluation by JICA Survey Team. Thus all participants of the present Steering Committee confirmed the result of calculation as described in the ANNEX-3 Design Framework, and agreed to start the system design by JICA Survey Team.
- e. JICA Survey Team summarized the design philosophy. In order to follow the agreed initial schedule of feasibility study to be conducted by the JICA Survey Team, the design framework, comprising basic data for water demand volume and design philosophy, discussed by the members of 3rd Steering Committee should not be altered from this date.
- f. GoCV side has shared necessary information, changes and results regarding water supply in the country with the JICA Survey Team. Therefore, it shall be considered that the design framework for the Feasibility Study, attached as ANNEX-3 Design Framework, is accepted by GoCV.

(CNAG Meeting – Ground water and Boron Issues)

- (3) Although the conclusion needs to be determined officially by CNAG in the GoCV level for ground water mixture and boron issues, JICA Survey Team will start the system design in Japan based on the agreed design framework with basic data and design philosophy by the 3rd Steering Committee.
 - a. JICA Survey Team met and explained and discussed on 3rd of June, 2010 with Ministers of GoCV during the 3rd Mission, Ms. Fátima FIALHO - Honorable Minister of Tourism, Industry and Energy, Ms. Cristina DUARTE - Honorable Minister of Finance, Mr. Jose Maria VEIGA Honorable - Minister of Environment Rural Development and Maritime Resources, though CNAG Meeting was not possible to be held before the present 3rd Steering Committee.
 - b. Though GoCV's principal policy of Ground water utilization is orientated to solely agricultural purpose, it shall be utilized for potable water unless the sufficient volume of potable water is supplied to users of each Municipality in Santiago Island. JICA Survey Team will not take into consideration the actual quantity of ground water used for potable water.
 - c. The Ministers recommended to follow EU standard concerning Boron content of drinking water as there is not CV standard. This subject is to be officially reported to JICA Headquarter and JICA Survey Team when GoCV decides this issue by the Ministry in charge.

(IEE Workshop)

- (4) Inter-Municipal Meeting for Environmental Issues was conducted and invited MTIE, DGA, and Chambers of Municipality on 25th of May, 2010 in Praia. Output and Confirmed items are also shown in ANNEX-4.

(Municipality Mayors Workshop)

- (5) Mayors Workshop was conducted and invited Mayors of all municipalities of Santiago island on 31st of May, 2010 for introduction of the JICA Study and its objectives using ANNEX-5. All participants understood the JICA Study.

(Fourth Steering Committee)

- (6) JICA Survey Team proposed the 4th Steering Committee after the submission of Interim Report (IT/R) of Feasibility Study to be held around August 2010.

MS

ohw

(End)

ANNEX-1 Third Steering Committee Presentation
ANNEX-2 Attendants List of the Second Steering Committee
ANNEX-3 Design Framework
ANNEX-4 IEE Workshop
ANNEX-5 Municipality Mayors Workshop

MS

afus

3rd Steering Committee
on
Water Supply System
Development Project in Santiago, Cape Verde
(JICA-II Project)

June 7, 2010 at Praia



Japan International Cooperation Agency

Toyo Engineering Corporation
Ingérosec Corporation
UNICO International Corporation

1

Topics and Modification after 2nd Committee

- 1. Critical Issues**
- 2. Project Work Shop**
- 3. IEE Work Shop**
- 4. Modification after 2nd Steering Committee**
 - 4-1. Water Demand and Frame Work**
 - 4-2. System Development Approach**
 - 4-3. Water Supply System**
 - 4-4. Cost Comparison**
- 5. Ground Water utilization and Boron content**
- 6. Basic Data and Design Philosophy**
- 7. Way Forward to Interim Report**

2

Critical Issues

- To solve the critical issues of the JICA project attending
 - Minister of Tourism, Industry and Energy
 - Minister of Finance
 - Minister of Environment Rural Development and Maritime Resourceswith JICA Study Team on 3rd June, 2010 in Praia.

- Solution of Critical issues:
 1. Desalination will be installed at Calheta Sao Miguel and Palmarejo with inter-municipality network.
 2. Other projects, which are considered regarding JICA Study,
 - Spanish cooperation project (5,000m³/day desalination expansion), and
 - World Bank cooperation project (5,000m³/day newly installed).
 3. Ground water will not be utilized for potable after JICA project completion.
 4. Boron content in potable water will follow to EU standard of less than 1.0mg/l.

3

Project Work Shop

The work shop was conducted inviting MTIE, INGRH, and Camara Municipals on 31st May, 2010 in Praia.

- Topics:
 1. JICA Study, its objective, time schedule, and methodology
 2. Water demand estimation with population horizon in Santiago island
 3. Water supply system with layout, production, reservoir, and transmission
 4. Scope of JICA and GoCV

- Discussion Items:
 1. System development approach was confirmed.
 2. Ground water utilization and Boron removal were discussed.
 3. Main reservoir capacity was discussed.
 4. Holding company idea in Santiago island was discussed.
 5. Production cost and tariff were discussed.

4

IEE Work Shop

● **Output:**

1. **Inter-Municipal Meeting for Environmental Issues was conducted inviting MTIE, DGA, and Camara Municipals on 25th May, 2010 in Praia.**
2. **Subjects discussed:**
 - 1) **Definition of category of JBIC guideline**
 - 2) **EIA mandate based on category.**
 - 3) **General issues to be considered in each municipality for formulation of Project**
 - 4) **Forthcoming EIA study**

● **Confirmed Items:**

1. **JICA will categorize the Project based on IEE.**
2. **Each Municipality Environment Plan shall be considered as the opinion of local stakeholders for F/S and IEE stage.**
3. **GoCV will prepare TORs for EIA based on recommendation of IEE.**

5

-
1. **Critical Issues**
 2. **Project Work Shop**
 3. **IEE Work Shop**
 4. **Modification after 2nd Steering Committee**
 - 4-1. **Water Demand and Frame Work**
 - 4-2. **System Development Approach**
 - 4-3. **Water Supply System**
 - 4-4. **Cost Comparison**
 5. **Ground Water utilization and Boron content**
 6. **Basic Data and Design Philosophy**
 7. **Way Forward to Interim Report**

6

Demand and Frame work at 2nd Committee

		South			Total South	North						Total North	Grand Total
		Praia	Ribeira Grande	Sao Domingos		Tarafal	Sao Miguel	SS do Mundo	Santa Cruz	Sao Lourenco	Santa Catarina		
(a)	Target Year (2020) Population	177,718	9,572	15,542	202,832	31,637	19,110	13,013	35,617	10,986	57,369	167,732	370,564
a-1	Urban	177,007	1,522	2,891	181,420	11,041	7,204	1,835	15,743	2,318	23,751	61,892	243,312
a-2	Rural	711	8,050	12,651	21,412	20,596	11,906	11,178	19,874	8,668	33,618	105,840	127,252
(b)	Service Coverage (%)	100	100	100	100	100	100	100	100	100	100	100	100
(c)	Served Population	177,718	9,572	15,542	202,832	31,637	19,110	13,013	35,617	10,986	57,369	167,732	370,564
c-1	Urban	177,007	1,522	2,891	181,420	11,041	7,204	1,835	15,743	2,318	23,751	61,892	243,312
c-2	Rural	711	8,050	12,651	21,412	20,596	11,906	11,178	19,874	8,668	33,618	105,840	127,252
(d)	Per-Capita Demand (LCD)												
d-1	Urban	100	100	100	100	100	100	100	100	100	100	100	100
d-2	Rural	50	50	50	50	50	50	50	50	50	50	50	50
(e)	Domestic Demand (m ³ /day)	17,736	555	922	19,213	2,134	1,316	742	2,568	665	4,056	11,481	30,694
e-1	Urban	17,701	152	289	18,142	1,104	720	184	1,574	232	2,375	6,189	24,331
e-2	Rural	36	403	633	1,071	1,030	595	559	994	433	1,681	5,292	6,363
(f)	Non-Domestic Demand (m ³ /day)	2,100	0	0	2,100	250	200	0	300	0	1,800	2,550	4,650
f-1	Tourism Demand	600	0	0	600	50	100	0	100	0	300	550	1,150
f-1-1	Number of Tourists (Daily)	2400	0	0	2,400	200	400	0	400	0	1,200	2,200	4,600
f-1-2	Per-Capita Demand (LCD)	250	0	0	250	250	250	0	250	0	250	1,000	1,250
f-2	Others	1500	0	0	1,500	200	100	0	200	0	1,500	2,000	3,500
(g)	Net Water Demand (m ³ /day)	19,836	555	922	21,313	2,384	1,516	742	2,868	665	5,856	14,031	35,344
(h)	Leakage Ratio (%)	24	20	10	23	24	16	20	28	10	28	25	24
(i)	Day Average Demand (m ³ /day)	26,100	693	1,020	27,813	3,137	1,804	928	3,983	736	8,133	18,722	46,535
(j)	Seasonal Peak Factor	1.3	1.3	1.3	1.3	1.3	1.3	1.3	1.3	1.3	1.3	1.3	1.3
(k)	Day Maximum Demand (m ³ /day)	33,930	901	1,325	36,157	4,078	2,346	1,206	5,178	957	10,573	24,338	60,495
					60%							40%	100%

Estimated daily maximum demand: 60,000m³/day.

- Northern area is 24,000m³/day (40% of island), and
- Southern area is 36,000m³/day (60% of island).

7

Demand and Frame work modified

Items	South			South total	North						North total	Total	Source
	Praia	Ribeira Grande	Sao Domingos		Tarafal	Sao Miguel	SS do Mundo	Santa Catarina	Santa Cruz	Sao Lourenco			
a Target Year (2020) Population (person)	177,978	17,992	17,331	188,971	28,377	21,127	13,127	36,871	36,106	11,194	188,448	389,319	Instituto Nacional de Estatística (INE)
a1 = a2	155,605	1,746	2,722	160,127	8,717	7,288	1,776	18,463	14,441	2,231	54,226	214,353	INE
a2	2,369	9,816	14,559	26,744	18,860	13,739	11,381	39,658	21,661	8,923	114,222	149,566	INE
b Overall Pipeline Service Coverage (%)	99.0%	80.0%	80.0%		90.0%	75.0%	60.0%	80.0%	85.0%	70.0%			Study team
b1	47.3%	10.9%	9.9%		64.1%	93.7%	15.4%	48.8%	76.9%	43.9%			INE
c Served Population	Connection ratio in Urban, data by INGRM, 100 %												
c1 = a x b	156,388	9,250	13,855	179,513	25,719	18,853	7,894	46,657	30,687	7,808	134,147	314,130	Connection ratio (Urban Total)
c2 = a1 x CONE %	155,609	1,745	2,722	160,127	9,717	7,988	1,776	18,663	14,441	2,231	54,226	214,353	100%
c3 = c1 - c2	789	7,504	11,093	19,386	16,002	8,485	6,118	27,994	16,246	5,577	79,921	99,777	Connection ratio (Rural Total)
c4 = a - c1	1,580	2,312	3,465	7,358	2,858	5,284	5,263	11,654	5,415	3,346	33,830	41,189	71%
c5 = a1 - c2	0	0	0	0	0	0	0	0	0	0	0	0	
c6 = a2 - c3	1,580	2,312	3,465	7,358	2,858	5,284	5,263	11,654	5,415	3,346	33,830	41,189	
d Per-Capita Average Demand (litter/person/day)													
d1	150	150	150	150	150	150	150	150	150	150	150	150	INGRR
d2	50	50	50	50	50	50	50	50	50	50	50	50	INGRR
d3	50	50	50	50	50	50	50	50	50	50	50	50	INGRR
d4	50	50	50	50	50	50	50	50	50	50	50	50	INGRR
e Domestic demand (m ³ /day)													
e1 = c2 x d1	23,341	262	416	24,019	1,458	1,110	270	2,799	2,166	335	8,134	32,133	
e2 = c3 x d2	63	600	887	1,551	1,280	674	459	2,240	1,300	446	6,431	7,882	
e3 = c5 x d3	0	0	0	0	0	0	0	0	0	0	0	0	
e4 = c6 x d4	79	116	173	368	143	243	263	583	271	167	1,692	2,099	
A = e1+e2+e3+e4	23,483	978	1,477	25,938	2,881	2,050	1,019	5,622	3,737	948	16,257	42,195	
f Tourism Demand													
f1	2,400	150	150	2,600	200	150	0	500	200	0	1,000	3,600	MTBE (Tourism Dept) + Study team
f2	700	700	700	2,100	700	700	700	700	700	700	700	700	Study team
f3	300	300	300	900	300	300	300	300	300	300	300	300	MTBE (Tourism Dept) + Study team
f = f1 + f2 + f3	904	21	21	946	42	21	0	105	42	0	210	796	
g Industries, office, hospital, others (m ³ /day)	3,000	0	0	3,000	50	100	0	500	100	0	750	3,850	MTBE (Industry Dept) + Study team
B = f + g	3,904	21	21	3,996	92	121	0	605	142	0	960	4,596	
C = A + B	26,887	1,000	1,548	29,534	2,973	2,171	1,019	6,227	3,879	948	17,217	46,751	
h Leakage Ratio (%)	15	15	10	15	15	10	15	15	15	10	15	15	Study team
h1	24	20	10	23	24	16	20	28	28	10	28	25	SAAS
D = C / (100% - h)	31,750	1,175	1,682	34,607	3,497	2,413	1,199	7,326	4,563	1,031	20,028	54,633	
E = D x (1 - f) / (100% - h)	237	10	9	256	28	9	0	48	20	0	98	354	Study team
E = D x f	31,997	1,165	1,691	34,963	3,517	2,422	1,199	7,378	4,583	1,031	20,125	54,990	
E = D x f	353	25	25	353	65	25	25	125	25	25	375	1,000	
2. Existing plant, including planned plant													
Existing Treatment Plant	5,000	(Palmarcos)		5,000					500		500	5,000	
Planned plant	5,000	(Palmarcos)		5,000					(Açadeira Nova)		0	5,000	
	5,000	(Spanish fund)		5,000							0	5,000	
	5,000	(Palmarcos)		5,000							0	5,000	
Total	10,000			10,000							0	10,000	
3. Necessary additional plant (1-2)													
Detail figure (m ³ /d)				19,863							19,863	39,490	
Round figure (m ³ /d)				20,000							20,000	40,000	

Estimated daily maximum demand: 55,000m³/day.

- Northern area is 20,000m³/day (36% of island), and
- Southern area is 35,000m³/day (64% of island).

8

System Development Approach modification

- Served population and its distribution
- Natural condition and Power supply condition
- Construction cost and operation cost
- O & M system and organization
- Environment and social consideration



- *Other project impacts of Spanish, WB, and CAIS*
 - *Inter-municipality network*
- were added during this field survey in Cape Verde*

9

Proposed System at 2nd Steering Committee

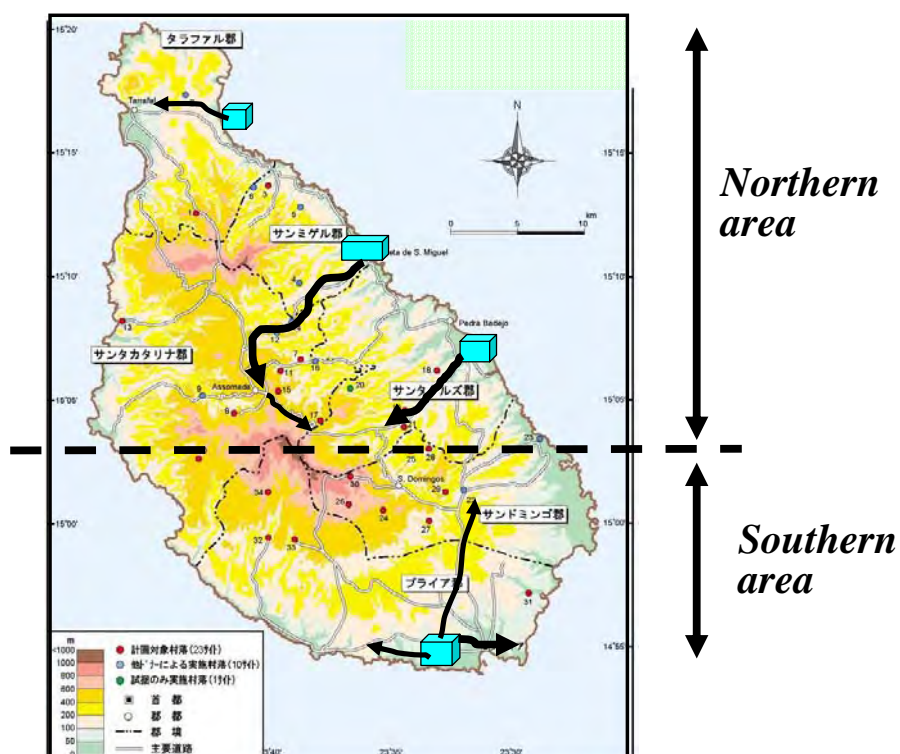

10

Modified System



Altitude levels are indicative
Pumps location and reservoirs locations are indicative

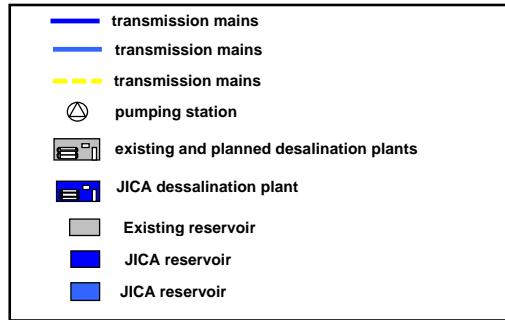

1. Two desalination system will be installed at Palmarejo and Calheta Sao Miguel.
2. Palmarejo Capacity:
 - Total Production 35,000m³/day
 - Existing and fixed plan 15,000m³/day
 - JICA plan 20,000m³/day
3. Calheta Capacity: 20,000m³/day
4. Desalinated water will be supplied to all communities by transmission line to reservoirs.

System Modification after 2nd Steering Committee

before

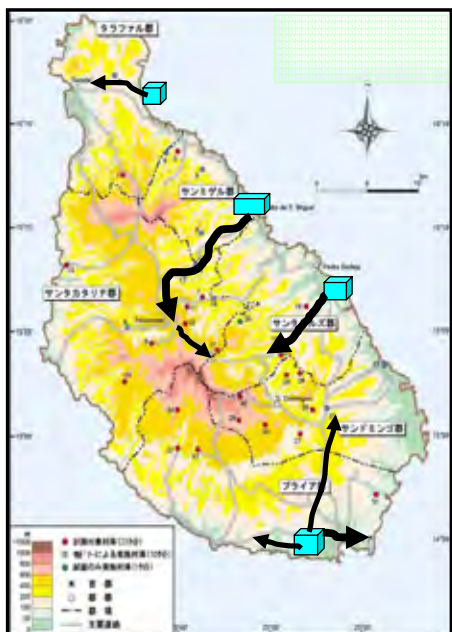

after



Altitude levels are indicative
Pumps location and reservoirs locations are indicative

Cost comparison of 3 + 1 cases on PR/R basis

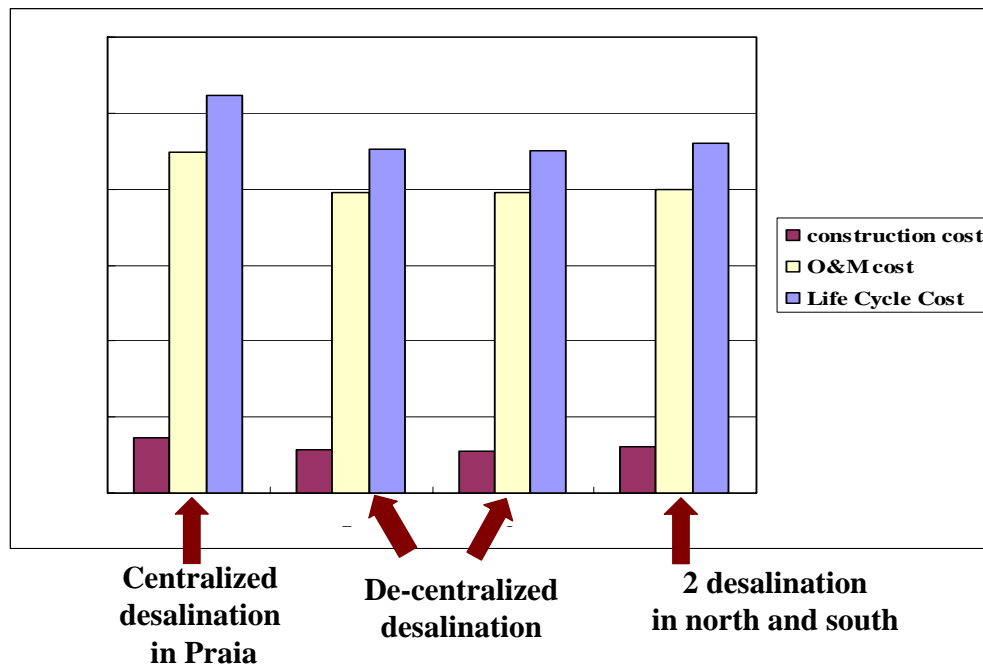

13

1. Critical Issues
2. Project Work Shop
3. IEE Work Shop
4. Modification after 2nd Steering Committee
 - 4-1. Water Demand and Frame Work
 - 4-2. System Development Approach
 - 4-3. Water Supply System
 - 4-4. Cost Comparison
5. Ground Water utilization and Boron content
6. Basic Data and Design Philosophy
7. Way Forward to Interim Report

14

Ground Water Utilization issues

- Major Advantage:
 - Desalination capacity reduction
 - Water tariff reduction
 - Boron content reduction
- Major Disadvantage:
 - Unstable supply
 - Unstable quality
 - Lack of irrigation water
- GoCV Policy

15

Boron Removal Solution for WHO guideline

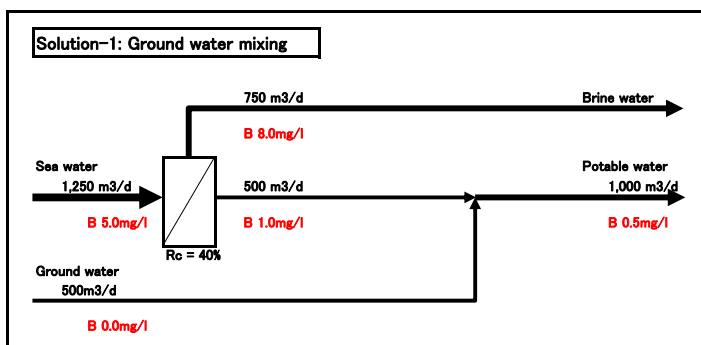

WHO: <0.5mg/l
 EU: <1.0mg/l
 Japan: <1.0mg/l

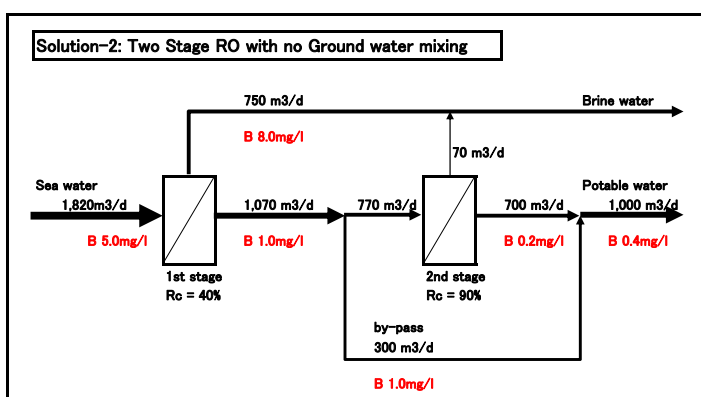

View points of
 - GW availability
 - GW utilization policy
 - Boron content of EU/JPN



EU standard might follow.

16

Basic Data for Design

1.	Unit of Measurement	SI (International System)
2.	Code and Standard	ISO, EN and/or JIS
3.	Sea water specification	To be identified (*)
4.	Product water specification	EU standard
5.	Effluent information	To be identified
6.	Ground water specification	To be identified (*)
7.	Soil information	To be identified (*)
8.	Supplied power	Medium voltage, 20/15/10/6kV

(*) : under analysis

17

Design Philosophy

1.	Desalination Technology	Reverse Osmosis
2.	Power source	Electric power purchased
3.	Major pumps	50% spare
4.	Reservoir capacity	1/2 day for consumer 1/3 day for production
5.	Instrumentation	Flow control for pumping Level control for reservoir
6.	Disinfection system	Chlorination
7.	Major monitoring	pH, Cl⁻, Conductivity

18

Way forward to Interim Report

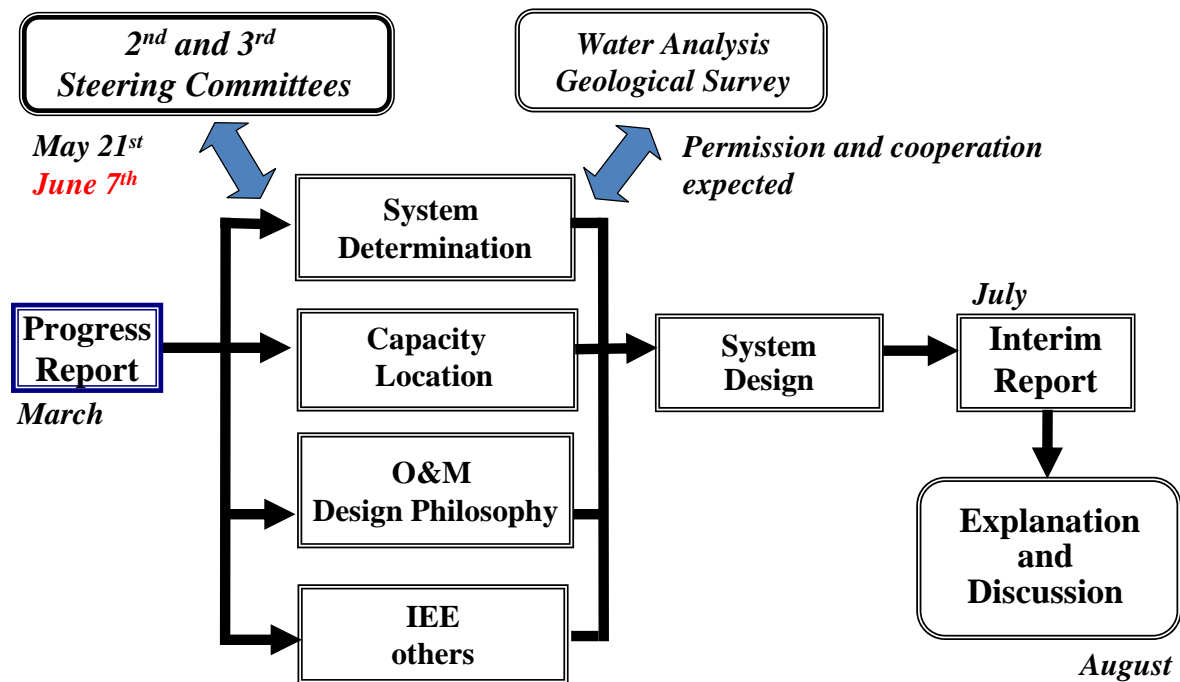

19

Interim Report contents

- **Water supply system specification**
- **Each desalination plant specification**
- **Each reservoir specification**
- **Transmission network specification with pumping**
- **Preparation of project financial analysis**
- **IEE result**
- **EIA study preparation**
- **Sea Water and Ground Water Analysis**
- **Soil Analysis**

Thank you and Obrigado

20

Attachment 1-5

Minutes of Meeting (4th Steering Committee)

&

Discussion materials

MOM
OF
PROJECT STEERING COMMITTEE
ON
FEASIBILITY STUDY
FOR
ENHANCED WATER SUPPLY SYSTEM PROJECT

DATE: August 27th, 2010

PLACE: Praia, Cape Verde

1. The Government of the Republic of Cape Verde (GoCV), in cooperation with the Government of Japan, intends to develop a structuring and strategic water sector project on the island of Santiago, aiming both at improving the water supply conditions, through the interconnection of water transmission and distribution networks, and at strengthening the production capacities;
2. Given the specific and strategic significance of the project, a diligent and efficient technical follow-up will be needed for the same;
3. In the scope of implementation of the above mentioned project, there will be a need to guarantee, to the GoCV, reliable technical counsel and assistance;
4. It is much advisable that the project be followed up and supported by all sectors and institutions which are, in one or other way, related to the water sector.
5. In this purpose, a Project Steering Committee has been officially established on 26th of January 2010 by the DISPATCH No. 007 / 2010 issued by MEGC (now MTIE).
6. The Project Steering Committee has met officially for the fourth time on the 23rd of August 2010, in the office of Cape Verde Stock Exchange (Bolsa-de Valores), Praia, Cape Verde. The list of participants is given in ANNEX-2.
7. During the Project Steering Committee, the JICA study team made a presentation regarding the Interim Report of the study as referred in ANNEX-1.
8. The Project Steering Committee members hereby confirmed full understanding of the Interim Report with main points discussed as per hereto the Attachment of the Minutes of Meeting.

By Chairman of the Project Steering Committee

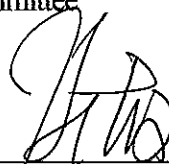

Mr. Pedro Alcantara Silva
MTIE / General Directorate of Energy



MINUTES of MEETING
on
THE INTERIM REPORT
for
THE PREPARATORY SURVEY
on
WATER SUPPLY SYSTEM DEVELOPMENT PROJECT
in
THE REPUBLIC OF CAPE VERDE

Praia, 27th August, 2010



Mr. Pedro Alcantara Silva
Directorate General for Energy,
Ministry of Tourism, Industry and Energy
The Government of the Republic of Cape Verde



Mr. Mitsutoshi SUZUKI
Lead Consultant of the Survey Team
Japan International Cooperation Agency

Attachment

Japan International Cooperation Agency (hereinafter referred to as "JICA") dispatched a mission (hereinafter referred to as "the JICA Mission") to the Republic of Cape Verde. Since their arrival on August 19th, 2010, the JICA Mission and officials of Government of the Republic of Cape Verde (hereinafter referred to as "the GoCV"), Ministry of Tourism, Industry and Energy, (hereinafter referred to as "MTIE") had detailed discussions on the Interim Report of the Preparatory Survey (hereinafter referred to as "the Survey") for Water Supply System Development Project (hereinafter referred to as "the Project").

In the course of discussions, both sides confirmed the main items described below. The JICA Study Team will proceed as planned up to December 2010, when the Survey comes to the end.

1. Conditions of the Survey in general

The JICA Mission stated that the results of discussions do not imply any decision or commitment by JICA for its prospective loan for the Project at this moment and the above results should be reported to the higher authority of JICA and the Government of Japan.

2. Reports submitted

The JICA Mission handed the following reports to MTIE during their staying in Praia

- 1) 7 hard copies of Interim Report
- 2) 1 hard copy and electrical data of Water Analysis Report
- 3) 1 electrical data of Geotechnical Survey Report

3. Major Points Discussed

(1) JICA Mission made a presentation regarding the Interim Report of the study using ANNEX-1 to all attendants listed in ANNEX-2.

(2) After the presentation, all attendants made discussion, question and comment as below:

a. RO core system

2 staged RO system is adopted in order to clear less than 0.5mg/liter of the Boron content in drinking water without ground water utilization as dilute.

CAPEX and OPEX of 2 staged RO system are about 5-10% higher than those of 1 staged RO system accordingly.

In future, when above Boron content become less than 2.4mg/liter, 2nd stage RO may be deleted.

b. Ground water utilization

No ground water will be utilized for drinking water after the system completion, due to the GoCV policy, the small CAPEX and OPEX reduction effect, and Boron removal technology using 2 staged RO system.

c. Transmission line material

Ductile Iron cement lining pipe (DICL) and High Density Polyethylene (HDPE) were proposed. Those materials are well known for water service, and are expected to be high corrosion resistance. The some existing transmission lines in Praia are producing red water due to corrosion during the long service period, and must be repaired or replaced.



d. Implementation Schedule

The proposed schedule is a JICA typical schedule.

Cape Verde side strongly expressed to shorten the schedule, since the water supply issue must be critical.

e. Water analysis

JICA Mission introduced the water analysis result conducted by Inpharma, Cape Verde.

JICA Mission commented that the fresh sea water around the candidate desalination facility construction site has no issue for the facility design.

JICA Mission also commented that some results of ground water analysis should be further investigated on Nitrate, Coliform and Total Hardness in particular. Those data were higher than allowable on the sampling date.

It was proposed that ground water of PT33 well in Santa Cruz should be analyzed, since the well is for potable water. JICA mission commented that purpose of this analysis is to determine the possibility of mixing ground water to RO product water, and ground water is already concluded not to be used, in this situation, further analysis is recommended to be discussed separately.

f. Power supply

JICA Mission commented that power supply might be a medium grade risk for the reliable operation of the water supply system.

The captive power for the system is likely installed for the OPEX reduction and the reliable operation, however the power supply system in Santiago island will be improved shortly.

As a result, the water supply system will have neither the captive power generation system nor the emergency power generation system.

g. Existing 500m³/day SWRO in Santa Cruz

The OPEX including power, fuel and chemicals is very high for Santa Cruz municipality.

Chemicals are high cost and difficult for purchasing in particular.

h. Boron content in drinking water

Boron content in drinking water was newly declared to be less than 1.0mg/liter on July 2010 by the Ministry of Health, the GoCV.

The JICA Mission insisted that keeping Boron content less than 0.5mg/liter was the expected performance and was required proper operation and maintenance of the desalination facility.

JICA Mission will not modify the technical specification regarding Boron in the Interim Report.

i. Water production by sea water desalination or ground water

Each municipality has each financial and geotechnical properties.

Municipalities, who can draw ground water easily with low cost, would like to continue utilizing ground water as potable.

j. Japan's ODA Loan

JICA Mission explained to conduct the preliminary economics study based on the general loan condition such as 1.4% p.a. interest, because STEP is not yet concluded to be applied.

JICA Mission expressed that this project could be applied to STEP loan, in case the requirements for STEP loan application will be satisfied.



k. Economics Study

JICA Mission commented their preliminary economic study on

- 1) the total system (huge CAPEX required) on the Santiago island
 - 2) the separated and phased systems of south and north regions on the island,
- then the project for Praia area (S1 Project) shows the best economics.

For further detail discussion among related parties, JICA Mission agreed to prepare,

- 1) Desalinated water production facility cost, and product water transmission facility cost
- 2) Initial investment cost, and operation & maintenance cost,
- 3) Rough Profit & Loss calculation in each municipality referring to real tariff.

l. O&M Planning

JICA Mission proposed the phased operation and maintenance planning.

The operation and maintenance planning will be further discussed by JICA Mission and the GoCV.

m. IEE and EIA

JICA Study Team conducted IEE, and no critical issue was found.

The GoCV will conduct EIA based on the Interim Report.

(End)

ANNEX-1: Fourth Steering Committee Presentation

ANNEX-2: Attendants List of the Second Steering Committee

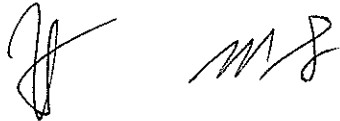

**4th. Steering Committee
on
Water Supply System
Development Project in Santiago, Cape Verde**

August 23, 2010 at Praia



Japan International Cooperation Agency

**Toyo Engineering Corporation
UNICO International Corporation
Ingérosec Corporation**

1

-
- 1. Introduction**
 - 2. Water Analysis and Geotechnical Survey**
 - 3. Basic Plan Development**
 - 4. Project Feasibility Study**
 - 5. Operation and Maintenance**
 - 6. Initial Environmental Examination**
 - 7. Conclusion and Way Forward**

2

1-1 Implementation Schedule of JICA Study

Year	2009			2010								2011										
	10	11	12	1	2	3	4	5	6	7	8	9	10	11	12	1	2	3	4	5	6	
Phase 1	Phase 1			Phase 2																		
Field Work	1st			2nd				3rd				4th				5th						
Submission of JICA Report	▲ IC/R					▲ PR/R					▲ IT/R			▲ DF/R		▲ F/R						
Steering Committee				☆				☆	☆		☆			☆								
Local Consultant	Socio Economica Analysis			water analysis geological survey																		
Phase 1	To analyze the project conditions																					
	To set the project scope, sites and components																					
Phase 2	To define Water Supply System as FS subject																					
	To conduct Conceptual Design with CAPEX/OPEX																					
	To conduct IEE																					
	To develop Financing Plan and conduct Economical Analysis																					

 *We are here.*

1-2 Outline of F/S Project

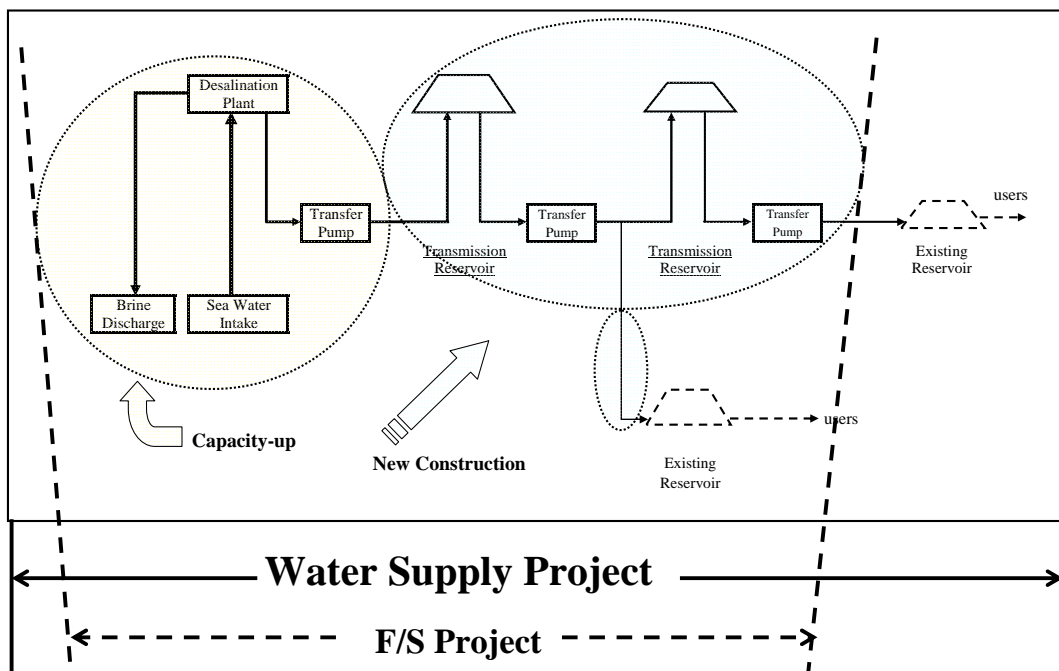

1-3 Each Report Topics

09/2009

IC/R

- KOM
- Methodology
- Approach
- Field Survey

03/2010

PR/R

- Horizon in 2020
- System Planning
- Socio Analysis
- donor projects
- 3 candidates

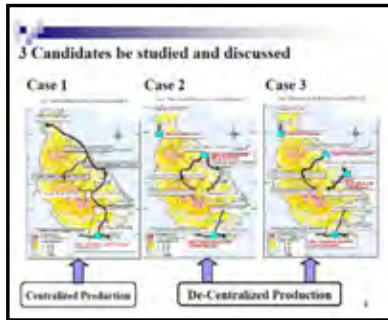

08/2010

IT/R

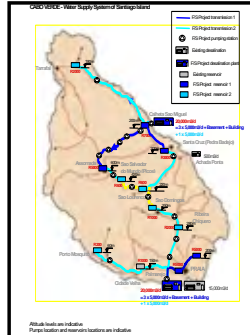

- Water Analysis and Geotechnical Survey
- Basic Plan Development
- Project Feasibility Study including
 - Material Balance of SWRO System
 - Technical Specification Development
 - Project Risk and Pre Economics
- Operation and Maintenance proposal
- Initial Environmental Examination

10/2010

DF/R

- Cost Estimation for JICA scope and GoCV scope
- Economics
- Funding
- ODA loan

12/2010

F/R

- *comments*
- *modification*
- *correction*

2-1 Water Quality Analysis

Water quality analysis was conducted by the local laboratory, Inpharma. Sampling water and its analysis results with some comments are as below:

- Desalinated water from existing facilities in Praia and Santa Cruz
 - Quality is generally within or close to the allowable level as drinking water
 - Cl⁻ and Boron contents in Praia are slightly higher than WHO guideline
- Beach well water for the existing plants in Praia and Santa Cruz
 - No serious issue is found
- Ground water near the candidate sites of the planned water distribution
 - Quality of the water is within allowable level as drinking water
 - Nitrate, Total Coliform and Total Hardness should be further investigated
- Sea water around the candidate sites for the planned desalination facilities
 - No serious issue for RO desalination application is found
 - Ordinary pre-treatment is required for RO desalination
 - Analysis result was applied to the planned facility design

2-2 Sampling Location and Desalinated Water

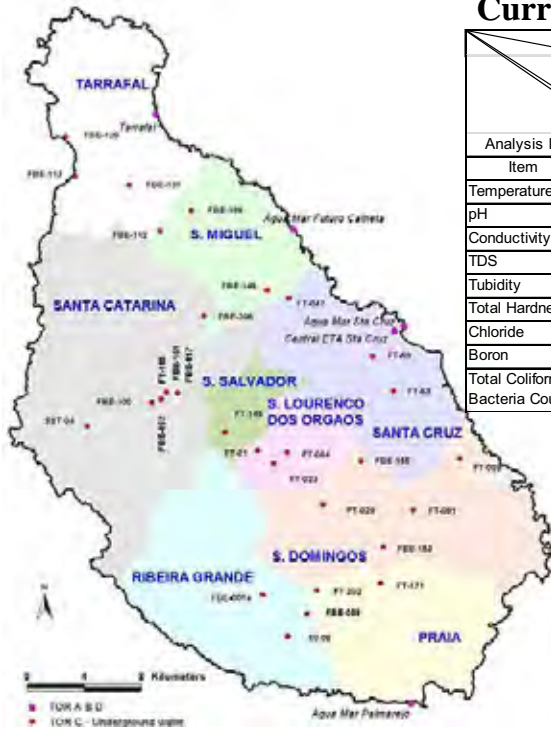

Current Desalinated Water Analysis

Sample Location		Praia	St. Cruz	Drinking Water Regulation		
Sampling No.		SP 1-1 SP 1-2 1-1 1-2	SS 1-1 SS 1-2	WHO	EU	Japan
Analysis Item		Range		WHO	EU	Japan
Item	Unit	Range		WHO	EU	Japan
Temperature	°C	16.4 ~ 19.1				
pH	-	6.4 ~ 7.4 at 21 °C		-	6.5 ~ 9.5	5.8 ~ 8.6
Conductivity	µS (cm)	940 ~ 1,100 at 25 °C			2,500	
TDS	mg/l	770 ~ 790		1,000		200~500
Turbidity	NTU	<0.3 (LQ)		1 (Max 5)	-	<2 deg
Total Hardness	mg(CaCO ₃)/l	71.1		-	-	<300
Chloride	mg (Cl ⁻)/l	320 ~ 800		<250	<250	<200
Boron	mg (B)/l	0.65 ~ 0.69		<0.5	<1.0	<1.0
Total Coliform Bacteria Count	ufc/100ml	0				

7

2-3 Ground Water Analysis

Sample Location		1)Sao Miguel	2) St. Cruz	3) Assomada and Picos	4) Sao Lourenço dos Orgaos	5) Tarrafal	6) Sao Domingos	7) Ribeira Grande de Santiago	8) Praia	Drinking Water Regulation		
Sampling No.		FBE-145 FBE-205 FBE-188 FBE-112	FBE-146 FT-09 FT-47 FT-59 FT-63	FT-186 FBE-116 FBE-161 FBE-100 FT-63 FBE-117	FT-145 SST-04 FT-23 FT-80 FT-84	FBE-129 SST-04 FBE-131 FBE-113 FT-84 FST-24	FBE-153 FBE-156 FT-81 PT-29 FT-208	58-09 58-01	FBE-58 FT-202 FBE-1A FT-171	WHO	EU	Japan
Analysis Item		Range	Range	Range	Range	Range	Range	Range	Range	WHO	EU	Japan
Item	Unit	Range	Range	Range	Range	Range	Range	Range	Range	WHO	EU	Japan
Temperature	°C	26.1~26.8	24.3 ~ 28.8	26.0 ~ 28.7	26.2 ~ 28.1	26.0 ~ 28.4	25.5 ~ 28.2	27.5 ~ 27.8	26.8 ~ 30.6			
pH	-	7.5 ~ 8.5 at 22 °C	7.2 ~ 7.8 at 20 °C	7.2 ~ 8.1 at 20 °C	7.4 ~ 7.7 at 22 °C	7.9 ~ 8.2 at 25 °C	7.0 ~ 8.0 at 23 °C	8.0 ~ 8.2 at 22 °C	8.2 ~ 8.4 at 24 °C	-	6.5~9.5	5.8~8.6
Turbidity	NTU	0.3(LQ) ~ 1.55	<0.3(LQ) ~ 0.62	<0.3 (LQ)	<0.3(LQ) ~ 0.68	<0.3(LQ) ~ 0.79	<0.3(LQ) ~ 0.72	<0.3 (LQ)	<0.3(LQ) ~ 0.41	1(Max 5)	-	<2 deg
Nitrate	mg(NO ₃)/L	1.0(LQ) ~ 73.9	5.6 ~ 54.4	31.0 ~ 71.6	<1.0 ~ 54.4	12.4 ~ 16.6	<1(LQ) ~ 54	12.3 ~ 16.1	10.6 ~ 24.8	<50	<50	<10
Nitrite	mg(NO ₂)/l	<0.01(LQ) ~ 0.02	<0.01 (LQ)	<0.01 (LQ)	<0.01(LQ) ~ 0.21	<0.01 (LQ)	<0.01 (LQ)	<0.01 (LQ)	<0.01 (LQ)	<3	<0.5	<0.05
Chloride	mg (Cl ⁻)/l	78 ~ 220	59 ~ 300	37 ~ 85	96 ~ 200	43 ~ 92	120 ~ 230	42 ~ 85	42 ~ 130	<250	<250	<200
Boron	mg (B)/l	0.05 ~ 0.14	0.06 ~ 0.13	0.05	<0.05 ~ 0.09	<0.05 ~ 0.06	0.07 ~ 0.12	<0.05(LQ)	<0.05(LQ) ~ 0.07	<0.5	<1.0	<1.0
Fluorine	mg (F)/l	<0.5(LQ) ~ 2.2	<0.5(LQ) ~ 0.6	<0.5 (LQ)	<0.5 (LQ)	<0.5 (LQ)	<0.5 (LQ)	<0.5 (LQ)	<0.5 (LQ)	<1.5	<1.5	<0.8
Total Coliform Bacteria Count	ufc/100ml	0 ~ 130	0 ~ 610	92 ~ 3,400	0 ~ 576	0 ~ 3,600	0 ~ 16	38 ~ 1,200	31 ~ 36			
Standard Plate Count Bacteria	ufc/ml	0 ~ >300	0 ~ >300	0 ~ 36	0 ~ 28	0 ~ >300	0 ~ 40	83 ~ 89	0 ~ 82			
Fecal Coliform Bacteria Count	ufc/100ml	0	0 ~ 119	0 ~ 5,800	0 ~ 19	0 ~ 140	0 ~ 35.2	11 ~ 83	0 ~ 40			
Iron	µg (Fe)/l	<60 (LQ)	<60(LQ) ~ 130	<60 (LQ)	<60(LQ) ~ <93(LQ)	<60(LQ) ~ 100	60(LQ) ~ 1,900	<60 (LQ)	<60 (LQ)	<300	<300	<300
Total Hardness	mg(CaCO ₃)/l	11.7 ~ 497.7	189.7 ~ 575	98. ~ 148	149 ~ 418	96 ~ 138	200 ~ 770	111 ~ 136	84.1 ~ 217.1	-	-	<300
Arsenic	µg (As)/l	<1(LQ) ~ 12	<1 (LQ)	<1 (LQ)	<1 (LQ)	<1 (LQ)	<1 (LQ)	<1 (LQ)	<1 (LQ)	<10	<10	<10
Cadmium	µg (Cd)/l	<0.5 (LQ)	<0.5 (LQ)	<0.5 (LQ)	<0.5 (LQ)	<0.5 (LQ)	<0.5 (LQ)	<0.5 (LQ)	<0.5 (LQ)	<3	<5	<10
Mercury	µg (Hg)/l	<0.1 (LQ)	<0.1 (LQ)	<0.1 (LQ)	<0.1 (LQ)	<0.1 (LQ)	<0.1 (LQ)	<0.1 (LQ)	<0.1 (LQ)	<1	<1	<0.5
Cr+6	µg (Cr)/l	<2 (LQ)	<2 (LQ)	<2(LQ) ~ 4	<2 (LQ)	<2 (LQ)	<2(LQ) ~ 6	4	3 ~ 7	<50	<50	<50
Lead	µg (Pb)/l	<5 (LQ)	<5 (LQ)	<5 (LQ)	<5 (LQ)	<5 (LQ)	<5 (LQ)	<5 (LQ)	<5 (LQ)	<10	<10	<10
Manganese	µg (Mn)/l	<4(LQ) ~ 48	<4 (LQ)	<4 (LQ)	<4(LQ) ~ 80	<4 (LQ)	<4 (LQ)	<4 (LQ)	<4 (LQ)	<400	<50	<50

8

2-4 Geotechnical Survey



- 3 bore holes for SWRO facility
- 20 trial pits for Transmission line
- 4 laboratory tests for construction

Survey Results are under review,
But no critical issues are found
at moment.

Actual survey was conducted by
Tecnasol, Portugal.

9

3-1 Population & Water Demand in 2020

Horizon of population in 2020 of the project targeted year was assumed to be about 370,566 persons in Santiago island in PR/R, but the horizon was newly assumed to be 355,319 persons by the latest Instituto Nacional de Estatística (INE).

The ratio of urban area to rural area was also newly assumed to be “60 to 40” instead of “66 to 34” in the island.

Water consumption rate was also re-estimated, and summarized as below:

	Urban	Rural
With public pipeline connection	150	80
Without public pipeline connection	50	50
For hotel user (tourist)	300	300

(unit: liter/day/person)

10

3-2 Water Demand and Production in 2020

Items	South			South total	North						North total	Total	data source
	Praia	Ribeira Grande	Sao Domingos		Tarrafal	Sao Miguel	SS do Mundo	Santa Catarina	Santa Cruz	Sao Lourenco			
a. Target Year (2020) Population (person)	157,978	11,562	17,331	186,871	28,577	21,137	13,157	58,321	36,102	11,154	168,448	355,319	Instituto Nacional de Estatística (INE)
a1 - Urban	155,609	1,746	2,772	160,127	9,717	7,388	1,776	18,663	14,441	2,231	54,226	214,353	INE
a2 - Rural	2,369	9,816	14,559	26,744	18,860	13,739	11,381	39,658	21,661	8,923	114,222	140,966	INE
b. Overall Pipeline Service Coverage (%)	99.0%	90.0%	90.0%		95.0%	90.0%	90.0%	95.0%	95.0%	90.0%			Steering Committee (SAAS)
in 2007	47.3%	10.9%	9.9%		64.1%	53.7%	15.4%	48.8%	76.9%	43.9%			INE
c. Served Population	Connection ratio in Urban, data by INGRH 100 %												
c1 = x x b	156,396	10,400	15,598	182,402	27,148	19,023	10,526	55,405	34,297	10,039	156,438	338,839	Connection ratio (Urban Total)
c2 = a1 x CONE %	155,609	1,746	2,772	160,127	9,717	7,388	1,776	18,663	14,441	2,231	54,226	214,353	100%
c3 = c1 - c2	789	8,660	12,826	22,275	17,431	11,625	8,750	36,742	19,856	7,808	102,212	124,486	Connection ratio (Rural Total)
c4 = a - c1	1,580	1,156	1,733	4,469	1,429	2,114	2,631	2,916	1,805	1,115	12,011	16,480	88%
c5 = a1 - c2	0	0	0	0	0	0	0	0	0	0	0	0	
c6 = a2 - c3	1,580	1,156	1,733	4,469	1,429	2,114	2,631	2,916	1,805	1,115	12,011	16,480	
d. Per-Capita Average Demand (litter/person/day)													
d1 - Urban, with pipe connection	150	150	150		150	150	150	150	150	150			INGRH
d2 - Rural, with pipe connection	80	80	80		80	80	80	80	80	80			INGRH
d3 - Urban, without pipe connection	50	50	50		50	50	50	50	50	50			INGRH
d4 - Rural, without pipe connection	50	50	50		50	50	50	50	50	50			INGRH
e. Domestic demand (m3/day)													
e1 = c2 x d1	23,341	282	416	24,019	1458	1110	266	2799	2166	335	8,134	32,153	
e2 = c3 x d2	63	693	1026	1,782	1394	850	700	2939	1556	625	8,177	9,969	
e3 = c5 x d3	0	0	0	0	0	0	0	0	0	0	0	0	
e4 = c6 x d4	79	58	87	223	71	106	132	146	90	56	601	824	
A = e1+e2+e3+e4	23,483	1,012	1,529	26,024	2,923	2,145	1,098	5,885	3,845	1,015	16,911	42,936	
f. Tourism Demand													
f1 - Number of Beds (beds)	2,400	100	100	2,600	200	100	0	500	200	0	1,000	3,600	MTIE/Tourism dept + Study team
f2 - Expected Average Occupancy	70%	70%	70%		70%	70%	70%	70%	70%	70%			Study team
f3 - Per-Capita Demand (litter/bed/day)	300	300	300		300	300	300	300	300	300			MTIE/Tourism dept + Study team
f = f1 x f2 x f3	504	21	21	546	42	21	0	105	42	0	210	756	
g. Industries, office, hospital, others (m3/day)	3,000	0	50	3,050	50	100	0	500	100	0	750	3,800	MTIE/Industry dept + Study team
B = f + g	3,594	21	71	3,596	92	121	0	605	142	0	960	4,556	
C = A + B	26,987	1,033	1,600	29,620	3,015	2,266	1,098	6,490	3,987	1,015	17,871	47,492	
h. Leakage Ratio (%)	15	15	15		15	15	15	15	15	15			Steering Committee (SAAS)
in 2007	24	20	10		24	16	20	28	28	10			SAAS
D = C / (100% - H)	31,750	1,219	1,882	34,848	3,548	2,666	1,292	7,635	4,690	1,194	21,025	55,873	
i. Seasonal Peak Factor (Tourism)	1.4	1.4	1.4		1.4	1.4	1.4	1.4	1.4	1.4			Study team
J = F x (i - 1) / (100% - H)	237	10	10	257	20	10	0	49	20	0	99	356	
E = D + J	31,987	1,229	1,892	35,105	3,567	2,676	1,292	7,684	4,710	1,194	21,124	56,229	
	57%	2%	3%	62%	6%	5%	2%	14%	8%	2%	38%	100%	
2. Existing plant, including planned plant													
Existing Desalination Plant	5,000	(Palmarco)		5,000					0		0	5,000	
Planned plant													
by Spanish fund	5,000	(Palmarco)		5,000							0	5,000	
by World Bank fund	5,000	(Palmarco)		5,000							0	5,000	
Total				15,000							0	16,000	
3. Necessary additional plant (1-2)													
Detail figure (m3/d)				20,105							21,124	41,229	
Round figure (m3/d)				20,000							20,000	40,000	

11

3-3 F/S Project Production Capacity

For decision of the F/S Project capacity, followings are applied:

- Whole potable water demand in 2020: 56,229m³/day (round 55,000m³/day)
- Existing Desalination Capacity in 2010: 5,000m³/day, in Praia
- Firmly Planned expansion plant: 5,000m³/day by Spain in Praia
- Firmly Planned plant: 5,000m³/day by WB in Praia
- Additional Capacity for whole demand: **40,000m³/day in island**
(= 55,000 - 5,000 x 3units)

It is noted that small desalination plants with capacity of 500 and 1,200m³/day production are already put in service, and some private based desalination projects are planned. Those capacities were not counted due to uncertainty.

3-4 Drinking Water Quality and Boron

- a. The drinking water quality supplied by the F/S Project basically follows WHO guidelines for Drinking Water, 3rd edition, 2008.
- b. Expected Boron content produced by the new desalination facility is less than 0.5mg/liter.
- c. Boron content was declared to be from less than 0.5 to less than 1.0mg/liter at 29-07-2010 by the Ministry of Health, Cape Verde by the Decree Law n° 8/2004 of 02/23/2004, B. O. n° 6.
- d. Though Boron content was declared, The current technical specification will not be changed. 0.5mg/liter is expected performance, the proper operation and maintenance will be required to keep the performance.

13

3-5 Ground Water Utilization

Ground water utilization was studied and discussed from the view points of

- the project investment cost reduction,
- Boron content reduction, and
- drinking water quality improvement.

Due to the following reasons, no utilization of ground water for the study is concluded.

- a. Investment cost impact might be very small if ground water will be utilized. Ground water production is about 4,000m³/day, but demand is about 56,000m³/day.
- b. No ground water is required to reduce Boron content in desalinated water, if 2 stage RO system will be applied,
- c. Cape Verde Government policy, ground water will be utilized for irrigation purpose after completion of enough network of desalinated water.

14

3-6 Material Balance and Boron Removal

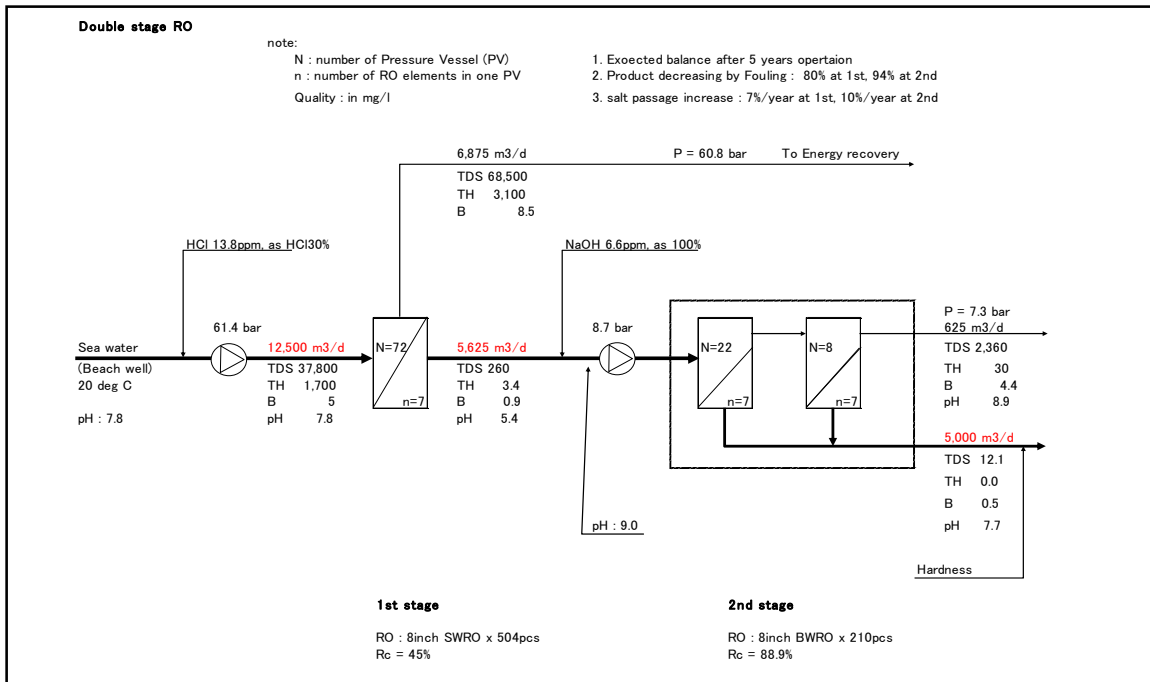

15

4-1 F/S Project Scope

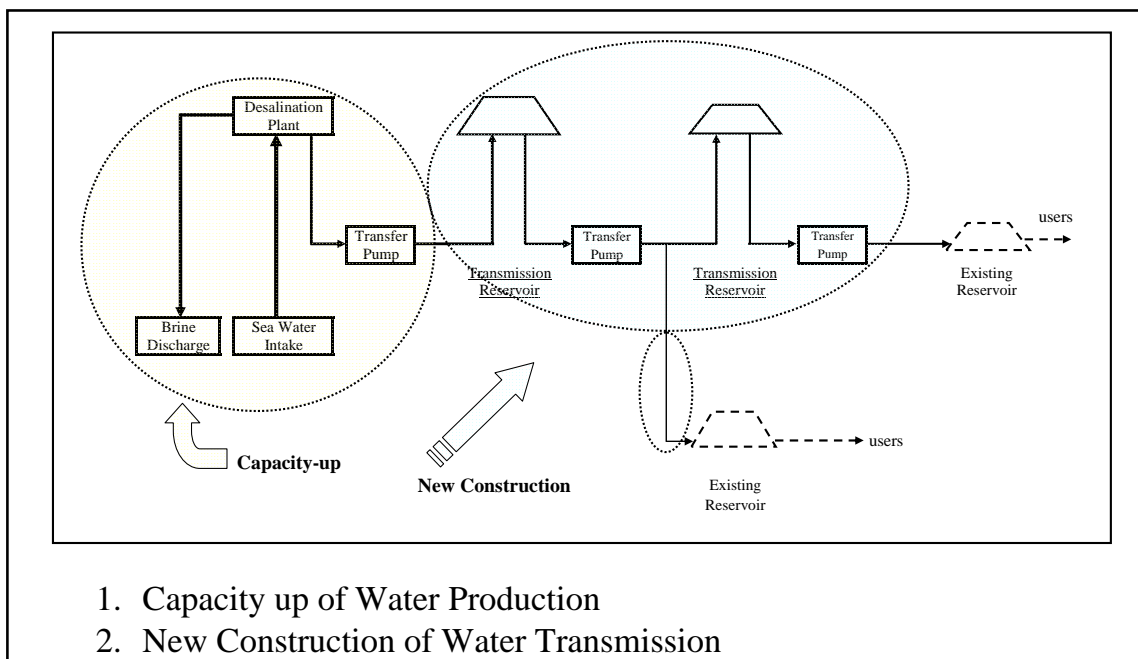

16

4-2 Sea Water Desalination Facility, Flow Sheet

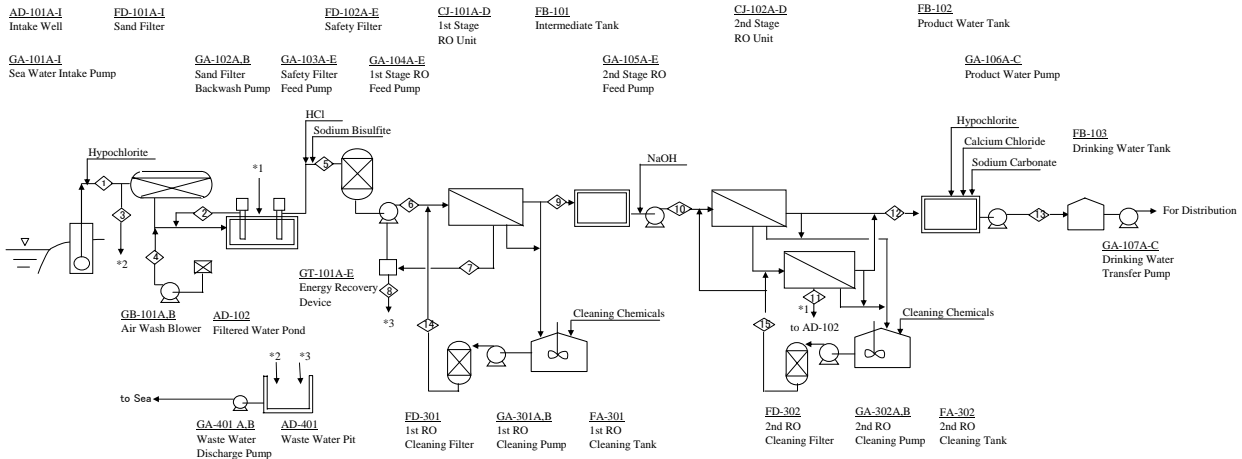

Stream No.	1	2	3	4	5	6	7	8	9	10	11	12	13	14	15
Description	Feed Sea Water	Filter Backwash Water	Backwash Waste to Sea	Filter Backwash Air	Safety Filter Feed	1st RO Feed Water	1st RO Brine	Brine Discharge to Sea	1st RO Permeate	2nd RO Feed Water	2nd RO Brine to Sea	2nd RO Permeate	Product Water	1st RO Cleaning Water	2nd RO Cleaning Water
Flow m ³ /d	50,000	2,083	580	1,180	50,000	50,000	2,083	1,146	27,500	22,500	2,500	20,000	20,000	-	-
Flow m ³ /h		87	24	49	2,083	2,083	87	48	1,146	937	104	833	833	430	180
Operation time	24 h/d	10min x 8 times/d	10min x 8 times/d	3min x 8 times/d	24 h/d	24 h/d	24 h/d	24 h/d	24 h/d	24 h/d	24 h/d	24 h/d	24 h/d	-	-
Temp °C	20	20	20	20	20	20	20	20	20	20	20	20	20	20	20
Pressure kg/cm ² G	3.0	2.0	1.0	0.5	2.0	61.4	60.8	1.0	1.0	11.0	1.0	1.0	5.0	5.5	5.5
TDS mg/l	37,800	37,800	37,800	-	37,800	37,800	68,500	68,500	260	260	2,350	12	12	12	12
Total Hardness mg/l as CaCO ₃	6,368	6,368	6,368	-	6,368	6,368	11,567	11,567	13	13	113	0	15	0	0
pH	7.8	7.8	7.8	-	7.8	7.8	7.5	7.5	5.4	8.7	8.9	7.7	7.7	-	-
Boron mg/l	5.0	5.0	5.0	-	5.0	5.0	8.5	8.5	0.9	0.9	4.0	0.5	0.5	-	-

PROCESS FLOW DIAGRAM
20,000m³/day Desalination Facility in Palmarejo
DWG.NO.

Palmarejo and Calheta are almost same

4-2 Sea Water Desalination Facility, Equipment List

Item No.	Service	No.	Type	Short Specification	Motor kW	Material
AD-101A-I	Intake Well	8+1		14" x 5000mm Depth		
AD-102	Filtered Water Pond	1	Semi-UG	520m ³ , 1000mmW x 4500mmH		Concrete
AD-401	Waste Water Pit	1	AG	240m ³ , 800mmW x 750mmH, x 4500mmH		Concrete
CJ-101A-D	1st Stage RO Unit	4 blocks		72 Pressure Vessels, 7 elements/PV, 8" element 5000mmW x 6000mmH x 6000mmH		
CJ-102A-D	2nd Stage RO Unit	4 blocks		30 Pressure Vessels, 7 elements/PV, 8" element 3000mmW x 6000mmH x 7500mmH		
FA-201	Hypochlorite Tank	1	Cone Roof	10m ³ , 2400mmD x 2600mmH, by Drum		FRP
FA-202	HCl Tank	1	Cone Roof	10m ³ , 2400mmD x 2600mmH, by Lorry		FRP
FA-203A.B	SBS Tank	2	Cone Roof	10m ³ , 2400mmD x 2600mmH, by Bag & Dissolving		FRP
FA-204	NaOH Tank	1	Cone Roof	10m ³ , 2400mmD x 2600mmH, by Lorry		FRP
FA-205A.B	Calcium Chloride Tank	2	Cone Roof	10m ³ , 2400mmD x 2600mmH, by Bag & Dissolving		FRP
FA-206A.B	Sodium Carbonate Tank	2	Cone Roof	10m ³ , 2400mmD x 2600mmH, by Bag & Dissolving		FRP
FA-301	1st RO Cleaning Tank	1	Cone Roof	20m ³ , 2400mmD x 6000mmH		FRP
FA-302	2nd RO Cleaning Tank	1	Cone Roof	10m ³ , 2000mmD x 4000mmH		FRP
FB-101	Intermediate Tank	1	Semi-UG	200m ³ , 4000mmW x 9000mmH x 6000mmH		Concrete
FB-102	Product Water Tank	1	Semi-UG	200m ³ , 4000mmW x 9000mmH x 6000mmH		Concrete
FB-103	Drinking Water Storage Tank	1	Cone Roof	7000m ³ , @Palmarejo, 29000mmD x 12000mmH		CS/Epoxy
FD-101A-E	Sand Filter	8+1		2400mmD x 8000mmL, Sand and Anthracite		CS/Rubber
FD-102A-E	Safety Filter	4+1	Vertical	1200mmD x 3000mmH, 5 micron Cartridge		CS/Rubber
FD-301	1st RO Cleaning Filter	1	Vertical	1200mmD x 3000mmH, Cartridge		CS/Rubber
FD-302	2nd RO Cleaning Filter	1	Vertical	800mmD x 3000mmH, Cartridge		CS/Rubber
GA-101A-I	Sea Water Intake Pump	8+1	Submerged	270m ³ /h x 50mH	55kW	Duplex SS or 316SS
GA-102A.B	Sand Filter Backwash Pump	1+1	Centrifugal	580m ³ /h x 20mH	55kW	Duplex SS or 316SS
GA-103A-E	Safety Filter Feed Pump	4+1	Centrifugal	530m ³ /h x 20mH	45kW	Duplex SS or 316SS
GA-104A-E	1st Stage RO Feed Pump	4+1	Centrifugal	530m ³ /h x 700mH	1400kW	Duplex SS or 316SS
GA-105A-E	2nd Stage RO Feed Pump	4+1	Centrifugal	240m ³ /h x 110mH	110kW	316SS
GA-106A-C	Product Water Pump	2+1	Centrifugal	420m ³ /h x 50mH	90kW	304SS
GA-107A-C	Drinking Water Transfer Pump	2+1	Centrifugal	420m ³ /h x 50mH @Palmarejo	90kW	304SS
GA-201A-E	Hypochlorite Injection Pump	2+2	Diaphragm	40L/h x 20mH	0.4 kW	SS/PTFE
GA-202A.B	HCl Injection Pump	1+1	Diaphragm	40L/h x 20mH	0.4 kW	SS/PTFE
GA-203A.B	SBS Injection Pump	1+1	Diaphragm	60L/h x 20mH	0.4 kW	SS/PTFE
GA-204A.B	NaOH Injection Pump	1+1	Diaphragm	60L/h x 20mH	0.4 kW	SS/PTFE
GA-205A.B	Calcium Chloride Injection Pump	1+1	Diaphragm	250L/h x 20mH	1.1 kW	SS/PTFE
GA-206A.B	Sodium Carbonate Injection Pump	1+1	Diaphragm	500L/h x 20mH	2.2 kW	SS/PTFE
GA-301A.B	1st RO Cleaning Pump	1+1	Centrifugal	420m ³ /h x 55mH	110kW	316SS
GA-302A.B	2nd RO Cleaning Pump	1+1	Centrifugal	180m ³ /h x 55mH	45kW	316SS
GA-401A.B	Waste Water Discharge Pump	1+1	Centrifugal	1400m ³ /h x 20mH	110kW	Duplex SS or 316SS
GB-101A.B	Air Wash Blower	1+1	Roots	1160m ³ /h x 4.5mH	30kW	GI
GD-203A.B	SBS Tank Mixer	2	Vertical		1.1 kW	CS/Rubber
GD-205A.B	Calcium Chloride Tank Mixer	2	Vertical		1.1 kW	CS/Rubber
GD-206A.B	Sodium Carbonate Tank Mixer	2	Vertical		1.1 kW	CS/Rubber
GD-301	1st RO Cleaning Tank Mixer	1	Vertical		1.1 kW	CS/Rubber
GD-302	2nd RO Cleaning Tank Mixer	1	Vertical		1.1 kW	CS/Rubber
GT-101A-E	Energy Recovery Device	4+1				
GF-401	Air Supply Package	1		300Nm ³ /h, with Air Compressor and Dryer	30kW	

Palmarejo and Calheta are almost same

4-2 Sea Water Desalination Facility, *General Layout*

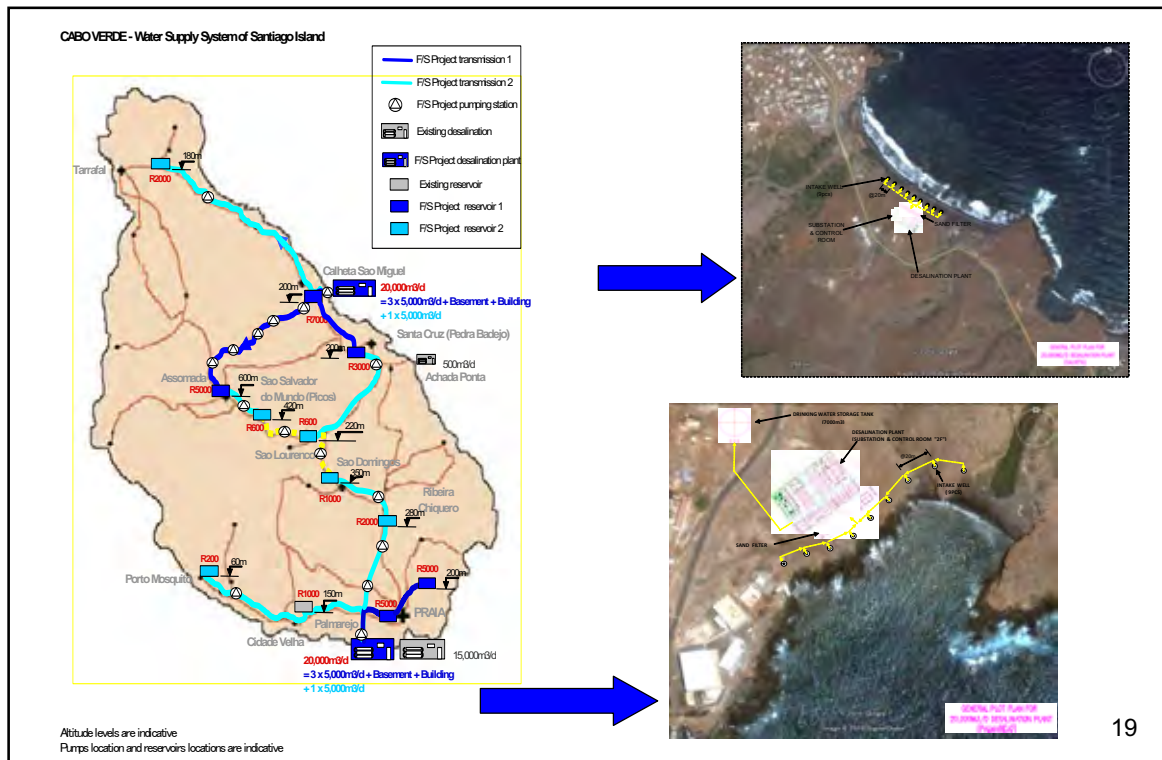

4-2 Sea Water Desalination Facility, *Plot Plan*

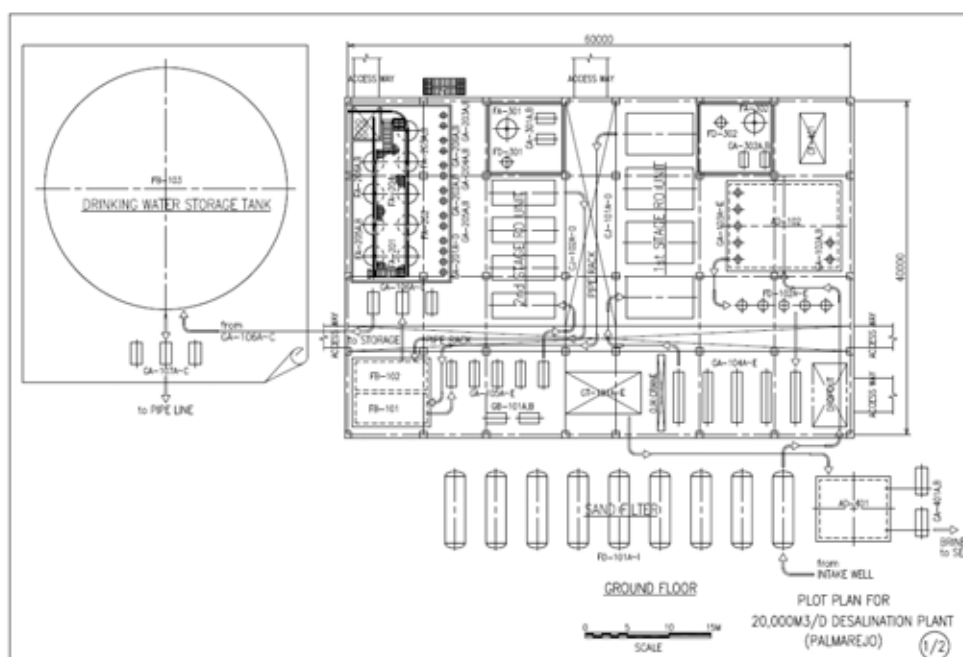

Palmarejo and Calheta are almost same

4-3 Water Transmission Facility, pump & reservoir

Pumping Station

No.	Flow (m3/h)	Pressure (barg)	Total power (kw) CAPEX	Installed power (kw) For	Power consumption (KW) For OPEX
PSS1	1599	16.0	1,661		1,110
PSS2	98	15.7	134		70
PSS3	126	14.1	154		80
PSS4	126	17.6	193		100
PSS5	126	14.7	161		85
PSS6	42	14.0	51		30
PSN1	1056	18.2	1,249		840
PSN2	598	13.3	689		350
PSN3	598	10.4	539		275
PSN4	598	10.6	552		280
PSN5	598	10.2	528		270
PSN6	80	13.7	95		50
PSN7	238	14.6	301		160

Reservoir

Name	Description	Capacity (m3)	Elevation (m)
RS1-5000	Praia – Tira Chapeu	5 x 1000 = 5,000	120
RS2-5000	Praia- Vila Nova	5 x 1000 = 5,000	110
Existing	Existing reservoir Cidade Velha	1 x 1000 = 1,000	150
RS3-200	Porto Mosquito	1 x 200 = 200	60
RS4-2000	Ribeiro Chiquero	2 x 1000 = 2,000	320
RS5-1000	Sao Domingos	1 x 1000 = 1,000	450
RN6-600	Joao Teves	1 x 600 = 600	220
RN5-3000	Pedra Badejo	3 x 1000 = 3,000	120
RN3-600	Picos	1 x 600 = 600	420
RN1-7000	Calheta Sao Miguel	7 x 1000 = 7,000	200
RN2-5000	Assomada	5 x 1000 = 5,000	600
RN4-2000	Tras Os Montes	2 x 1000 = 2,000	220

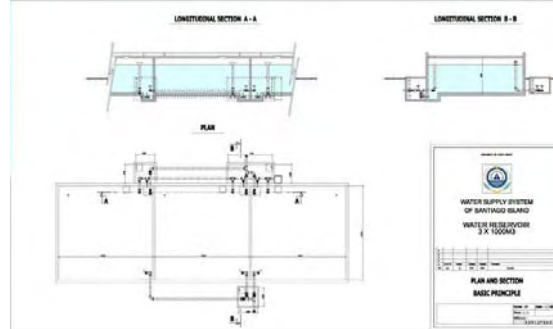
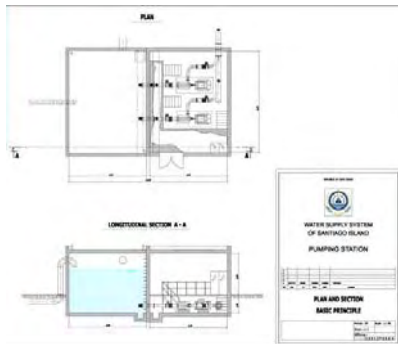

23

4-4 Implementation Planning

- No critical issue of the construction of the system is found.
- Due to the long transmission line construction, plural construction teams would be organized for the effective and reasonable planning.

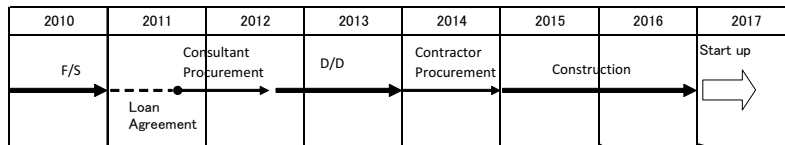

DESCRIPTION	YEAR	2010 2011 2012 2013 2014 2015 2016 2017																																				
		Calendar Mth	Year 1												Year 2												Year 3											
GENERAL SCHEDULE	Construction Team No.	1	2	3	4	5	6	7	8	9	10	11	12	1	2	3	4	5	6	7	8	9	10	11	12	1	2	3	4	5	6	7	8	9	10	11	12	
North Area																																						
N1 Desalination Facility Construction and Installation	2 teams																																					
Water Transition Facility Construction																																						
N2 Desalination Facility Installation	3 teams																																					
Water Transition Facility Construction																																						
Commissioning																																						
South Area																																						
S1 Desalination Facility Construction and Installation	1 team																																					
Water Transition Facility Construction																																						
S2 Desalination Facility Installation	1 team																																					
Water Transition Facility Construction																																						
Commissioning																																						

24

4-5 Project Risk

	Risk Occurrence Possibility			Risk Description	Countermeasure
	low	medium	high		
Technical					
Capacity	✓				
Sea Water Specification	✓				
Potable Water Specification	✓				
Water Transmission		✓		unforeseen obstacle or soil condition	route change will be discussed
Power Supply		✓		emergency failure	emergency generator will be installed
Beach Well Water		✓		water volume decreasing	another well will be newly digged
Regulation	✓				
Commercial					
Funding	✓				
Yen Loan	✓				
Market	✓				
Inflation	✓				
Concession	✓				
Environment					
Regulation	✓				
Permission	✓				
Natural Conditions	✓				
Social Consideration	✓				
others					
Policy	✓				
Human Resources	✓				
Construction Site	✓				
Operation		✓		operation material shortage	material will be purchased
Maintenance		✓		maintenance material shortage	material will be purchased
other projects impact	✓				

25

4-6 (1) Economics Analysis, - *presupposition* -

- Case “Total”, “S1”, “S2”, “N1” and “N2” are studied ... ref 4-6(2)
- Production capacity, in “Total” case ... ref 4-6(3)
 - Production: 40,000m³/d, with 365days/year operation
 - Sales : around 85% (34,500m³/d) of production
 - No safety margin is considered
- Project period
 - Construction : 2 years for EPC, including trial run ... ref 4-4
 - Project life for Economics analysis : 20 years
- Financial condition
 - Equity:15%
 - Loan: 85% (25years Yen loan from Japanese Government, 1.4% p.a. interest)
 - Investment 60% at 1st year, 40% at 2nd year
- Project cost: as per slide 4-6(4)
- Tariff: 5.0US\$/m³ (395CVE/m³) in 2020, in base case ... ref 4-6(5)
- Depreciation
 - Manner of depreciation : Straight-line method, with Zero salvage value
 - Service life : 20 years, for Economics Analysis purpose
- Unit cost for study
 - Electricity: 21CVE/kWh (=0.265US\$/kWh), based on ELECTRA tariff
 - 10,000 US\$/year/person, including overhead
 - Maintenance, including membrane, chemical are considered accordingly

26

4-6 (2) Project Scoping, - each project -

CABO VERDE - Water Supply System of Santiago Island

Project Name	Location	SWRO				Civil work		Transmission and reservoirs for	
		Train capacity (m ³ /d)	trains (unit)	Total quantity (m ³ /d)	Civil work, including equipment base	Building	Service Area	m ³ /d	
S1	Palmarejo	5,000	3	15,000	for all (4 trains)	for all (4 trains)	Praia	15,000	
S2	Palmarejo	5,000	1	5,000	---	---	Ribiera Grande Sao Domingo	5,000	
N1	Calheta	5,000	3	15,000	for all (4 trains)	for all (4 trains)	Sao Miguel Santa Catarina Santa Cruz	15,000	
N2	Calheta	5,000	1	5,000	---	---	Tarrafal SS.Mundo Sao Laurence	5,000	
Total				40,000				40,000	

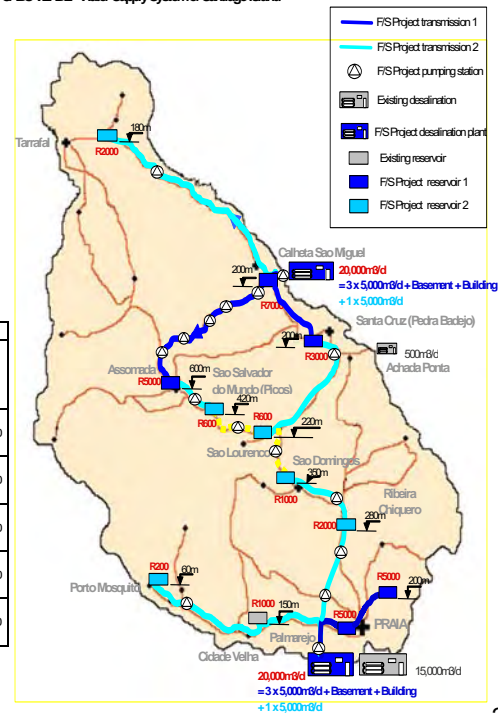

27

Altitude levels are indicative
Pumps location and reservoirs locations are indicative

4-6 (3) Production and Sales Plan (unit: m³/day)

Project name			Delivery (Sales) = Production - Leakage	Leakage = Production x 15%	Production			
Name	Service Area	Population, in 2020 (persons)			Delivery + Leakage	Round figure	F/S Project	Others (Spain, WB)
<i>by others</i>			13,500	2,382	15,882	15,000	---	15,000
S1	Praia	157,978	13,500	2,382	15,882	15,000	15,000	---
S2	Ribiera Grande Sao Domingo	28,893	3,000	529	3,529	5,000	5,000	0
N1	Sao Miguel Santa Catarina Santa Cruz	115,560	13,000	2,294	15,294	15,000	15,000	0
N2	Tarrafal SS.Mundo Sao Laurence	52,888	5,000	882	5,882	5,000	5,000	0
Total (S1+S2 +N1+N2)		355,319	34,500	6,088	40,588	40,000	40,000	0
	<i>Others</i>		13,500					15,000
	Grand Total		48,000				55,000	

28

4-6 (4) F/S Project Cost, - preliminary -

Project name		Plant Cost				Project Cost	
		SWRO		Transmission		Total	(= Plant cost x 1.4)
Name	Service Area	m3/d	mio \$	m3/d	mio \$	mio \$	mio \$
S1	Praia	15,000	23.2	15,000	8.6	31.8	44
S2	Ribiera Grande Sao Domingo	5,000	5.8	5,000	13.7	19.5	27
N1	Sao Miguel Santa Catarina Santa Cruz	15,000	23.2	15,000	24.8	48.0	67
N2	Tarrafal SS.Mundo Sao Laurence	5,000	5.8	5,000	19.3	25.1	35
Connection						0.0	0
Total		40,000	58.0	40,000	66.4	124.4	174

Project cost is calculated by adding project implementation cost in future such as consultant fee, land acquisition fee, detail design fee etc. From in-house data, 1.4 times of Plant cost is applied. 29

4-6 (5) Current Sales Price, tariff

Area	South					North								Total		
	S1	S2			South total	N1				N2					North total	
Municipality	Praia	Ribeira Grande	Sao Domingos	Average		Sao Miguel	Santa Catarina	Santa Cruz	Average	Tarrafal	SS do Mundo	Sao Lourenco	Average			
Tariff in 2008, consumption range of 6m3/month	CVE/m3	333	354	280	309	331	280	120	280	198	134	310	150	175	192	279
	US\$/m3	4.2	4.5	3.5	3.9	4.2	3.5	1.5	3.5	2.5	1.7	3.9	1.9	2.2	2.4	3.5
Sales quantity in 2020 (m3/d)	Normal	26,987	1,033	1,600		29,620	2,266	6,490	3,987		3,015	1,098	1,015		17,871	47,491
	Peak	237	10	10		257	10	49	20		20	0	0		99	356
	Total	27,224	1,043	1,610		29,877	2,276	6,539	4,007		3,035	1,098	1,015		17,970	47,847
	Round Figure	13,500	3,000				13,000				5,000				(18,000)	34,500
	by Others	13,500				(30,000)										

USD 1 = 79.1 CVE
Praia area 333 CVE/m3= 4.2 USD/m3
Other Praia 207 CVE/m3= 2.6 USD/m3

Data source: Electra for Praia, and SAAS for other municipality than Praia

Average tariff in other area than Praia is 207 CVE/m3. According to Social survey in 2009 by JICA study team, these area

may accept tariff increase up to 200-350 CVE/m3 (=1.7 times max). Therefore 1.4 times of average tariff of 279 CVE/m3 (=3.5 US\$/m3) (= 5US\$/m) is set as base case in 2020.

4-6 (6) F-IRR Calculation Results, - preliminary -

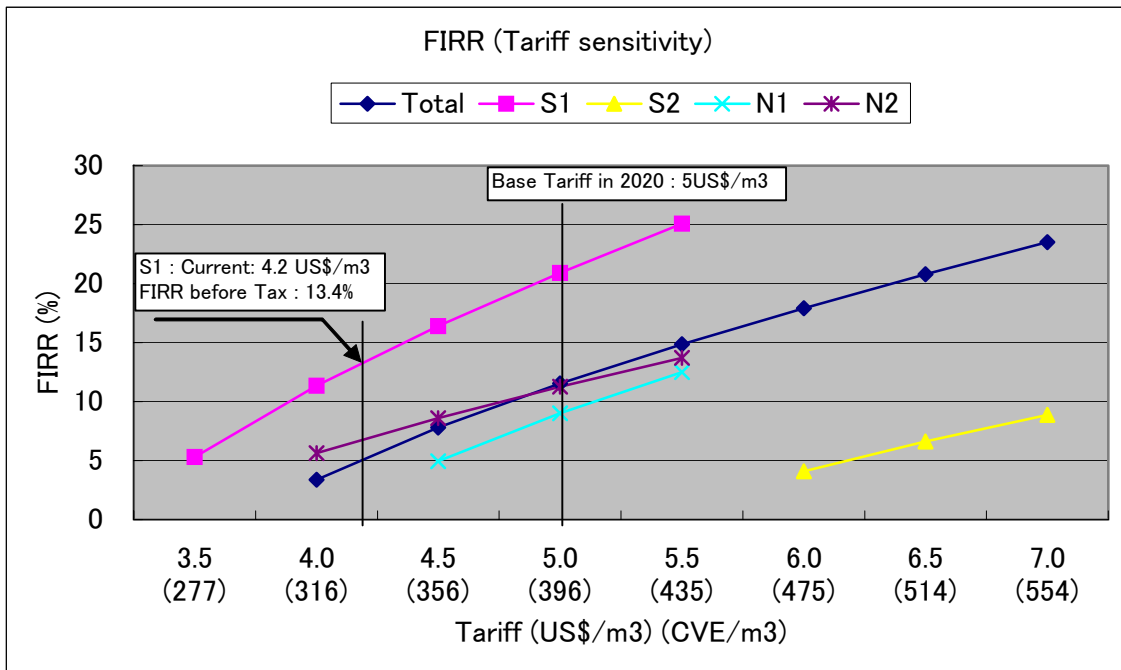

5US\$/m3 is enough feasibility in all cases except "S2".

31

4-6 (7) Economics Analysis, - summary -

(a) Summary of profitability study

S1 shows most stable financial result from view points of F-IRR and DSCR.

F-IRR: 20.9% @ 5.0US\$/m³ at base tariff

13.4% @ 4.2US\$/m³ at current tariff

DSCR: 3.67 and higher @ 1st Operation year and afterward

(b) Tariff of potable water

Sales price is set up only based on the current tariff of potable water.

This tariff shall be politically adjusted.

All cases except "S2" show healthy financial economics.

In case people cannot accept this tariff,

the subsidy application by the GoCV is recommended.

32

5. Operation and Maintenance Planning

There is no organization which comprehensively manages and supervises waterworks and O&M at whole island level.

Considering the current waterworks situation and the project nature, the O&M systems in the transition period and in the future are recommended.

In the transition period, two water supply systems will be established in the south and the north in the island. The desalinated water produced by 2 desalination facilities in the southern and the northern regions will be transmitted and distributed to target municipalities.

As a future scenario, establishing an inter-municipal public holding company will manage and supervise the water supply system comprehensively in southern and northern regions.

5-1 O&M Planning in Transition Period

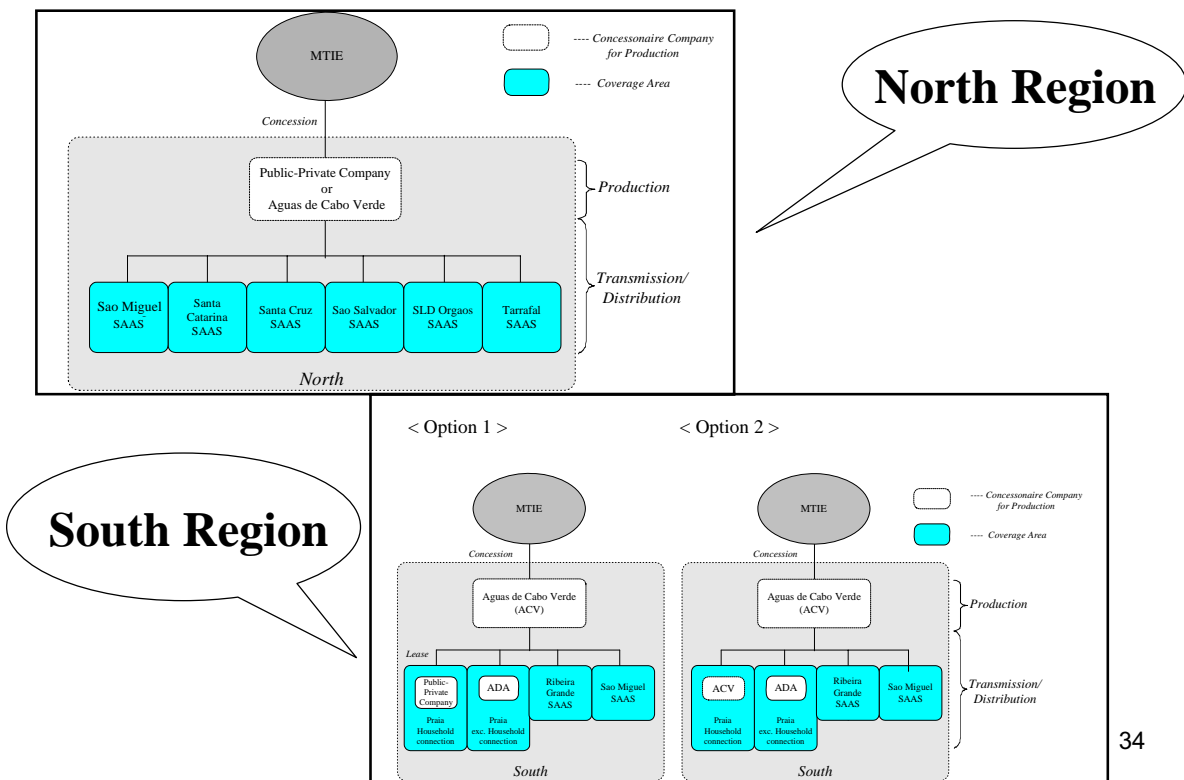

5-2 O&M Planning in Future

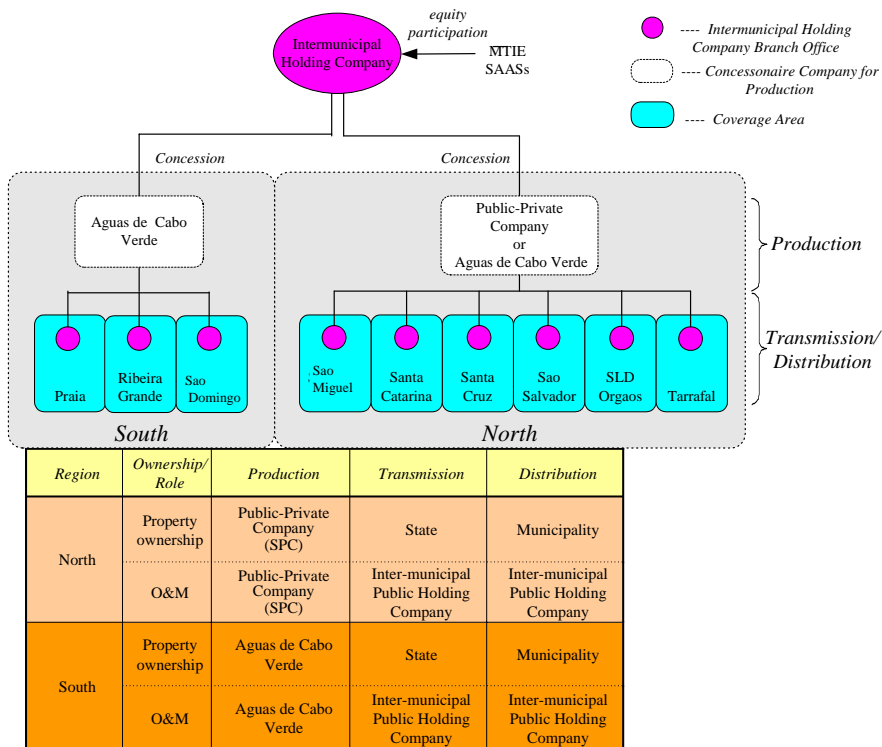

35

6. Initial Environmental Examination, IEE

IEE of the F/S Project took place from October 2009 to July 2010.

IEE has been carried out in accordance with the JBIC Guidelines dated April 2002 and relevant laws of the GoCV.

In IEE stage, general environmental impacts were presumed according to the dialogue with local stake holders for environmental management through “Inter-municipal Meeting for Environmental issues” conducted by the Study team on May 2010 in Praia.

As conclusion, general measures for environmental management are summarized in each municipality’s Municipality Development plan (PDM) and Municipality Environmental plan and those measures should be considered at the stage of the F/S Project formation and IEE and EIA.

36

7-1 Conclusion

1. JICA Study Team developed the Technical Specification of Water Supply System on the Santiago island with MTIE of GoCV, and no specific issue was found.
2. JICA Study Team conducted the preliminary Economics Analysis on the total F/S Project and separated projects of S1, S2, N1, and N2 based on the developed system specification.
All cases except “S2” show healthy financial economics.
3. JICA Study Team proposed the Operation and Maintenance systems in the transition period and in the future, but those systems should be further discussed.
4. JICA Study Team conducted the Initial Environmental Examination, and no specific issue was found.

37

7-2 Way Forward

1. JICA Study Team will conduct the CAPEX and OPEX estimation for their project scope with MTIE of GoCV.
2. MTIE of GoCV will conduct the CAPEX and OPEX estimation for their project scope with JICA Study Team.
3. Draft Final Report will be developed through home office work in Japan and field work in Cape Verde with careful discussion among MITE, JICA, and JICA Study Team based on the Interim Report.
4. Draft Final Report will be prepared by the end of October.
 - 1) Its discussion will be held on November in Praia.
 - 2) Final Report will be developed by the end of this year.
5. The major contents of the (Draft) Final Report are as follows:
 - 1) CAPEX and OPEX estimation
 - 2) Project Economics Study
 - 3) Financing and funding in consideration of Japan’ ODA loan

38