

DETAILS OF PARKING SPACE S=1:200

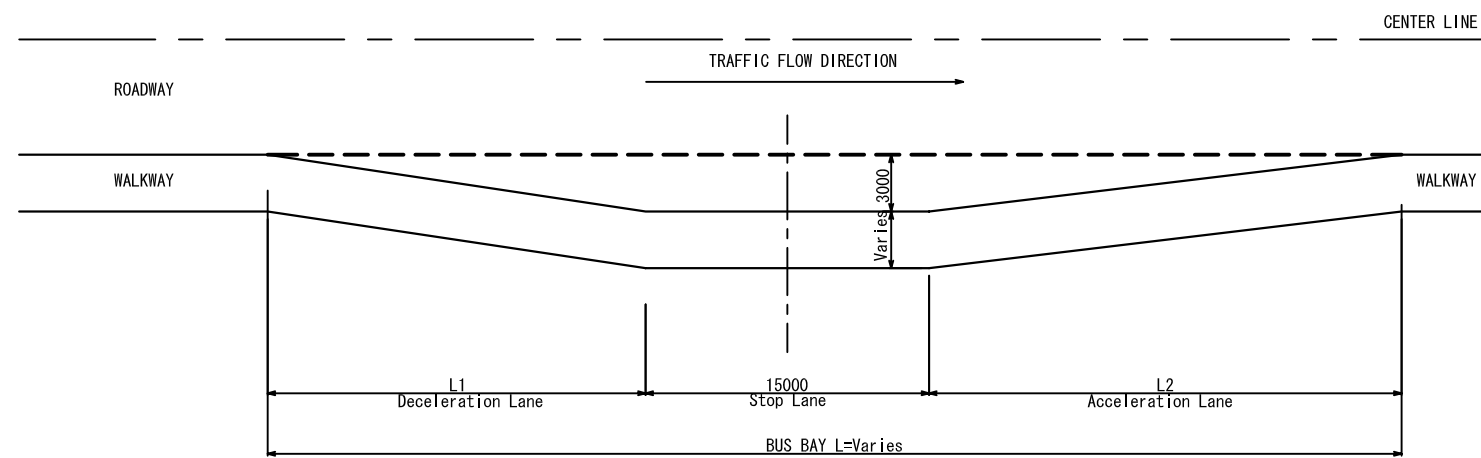

DETAILS OF BUS BAY 1:200

LIST OF PROPOSED BUS BAY LOCATIONS

No	STATION	SIDE		DESIGN SPEED (km/h)	DIMENSION		REMARKS
		L	R		L1	L2	
1	0+037	L	R	40	12	13	Ave. de Lac
2	0+847		R	40	20	25	Ave. de la Plage
3	0+851	L		60	20	25	ditto
4	1+630	L		60	20	25	ditto
5	1+652		R	60	20	25	ditto
6	2+437	L		60	20	25	Ave. de Lac
7	2+448		R	60	20	25	ditto
8	Y0+457	L		50	15	20	Bld. Yaranda
9	Y0+507		R	50	15	20	ditto
10	Y0+972		R	50	15	20	ditto
11	Y1+032	L		50	15	20	ditto

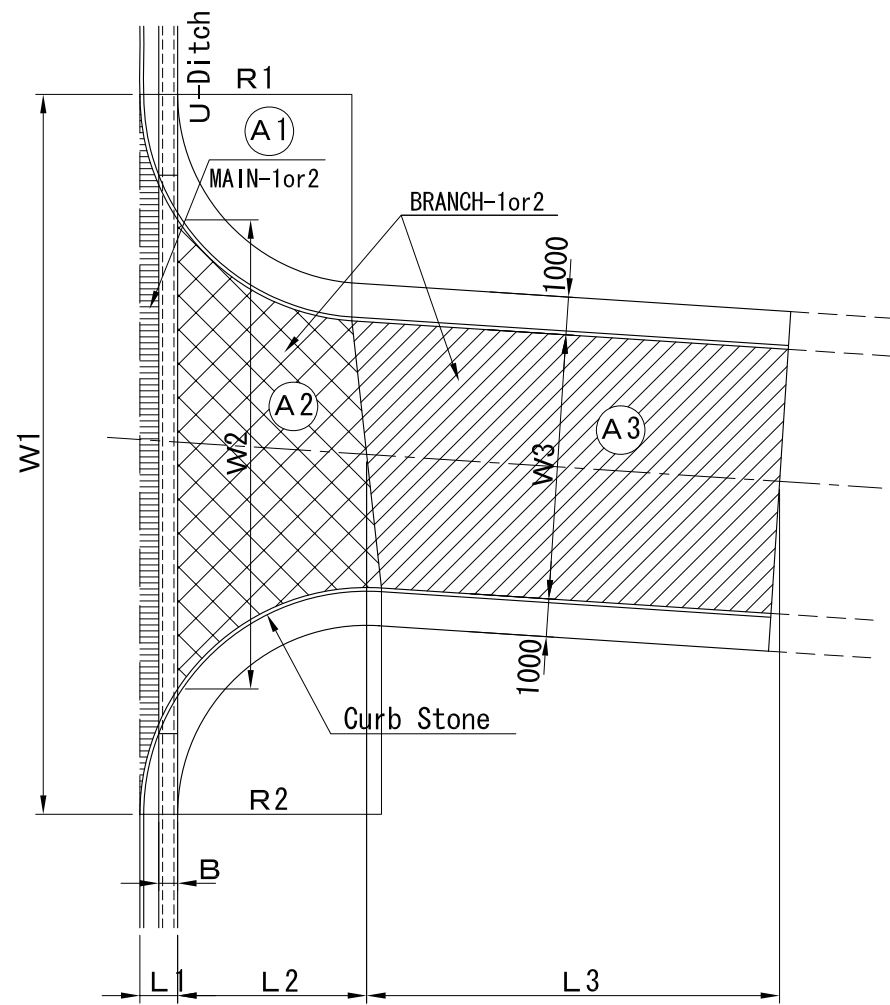

PLAN TYPE-1

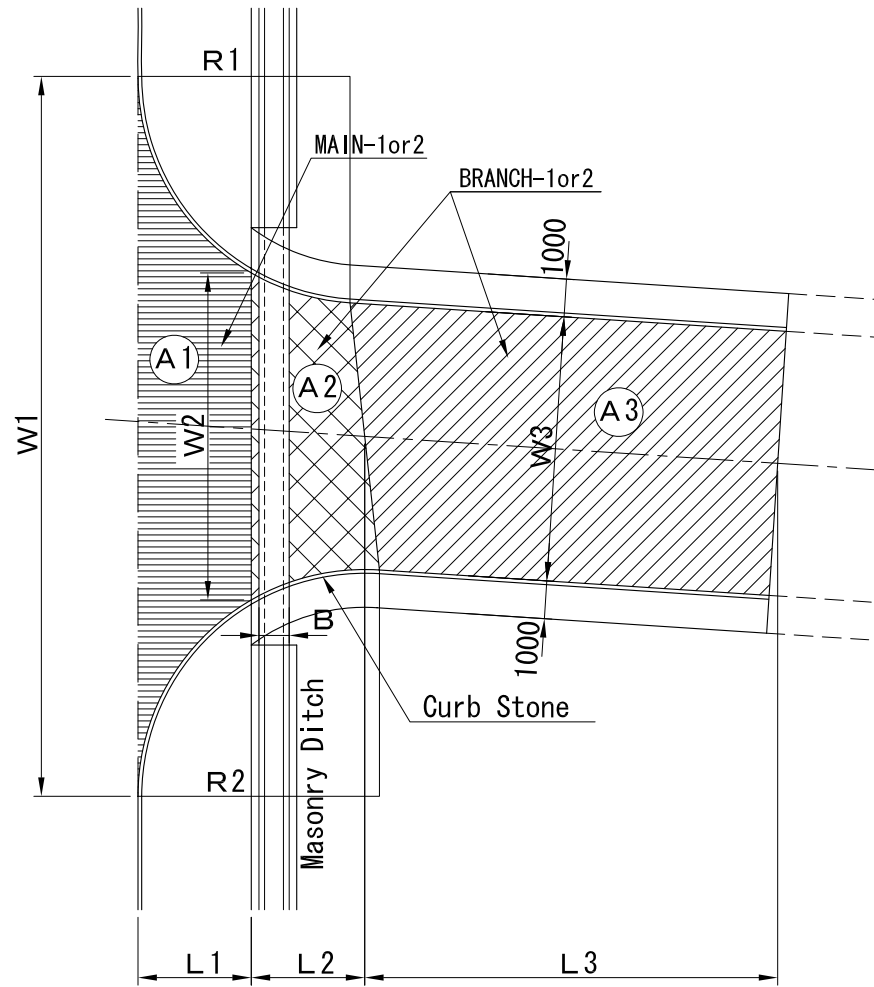

PLAN TYPE-2

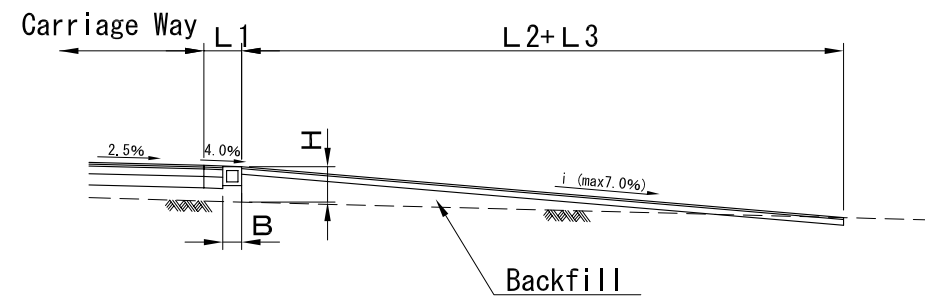

SECTION TYPE-1

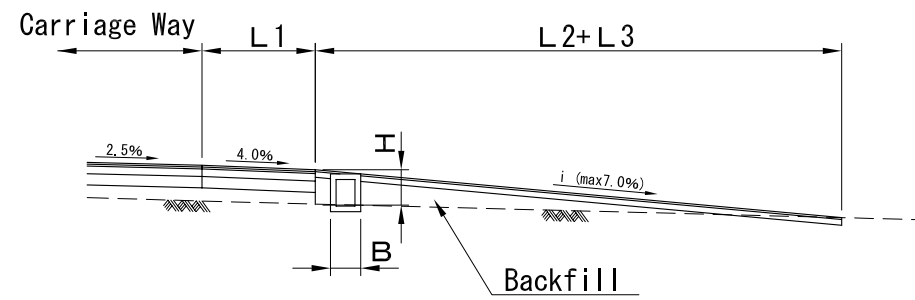

SECTION TYPE-2

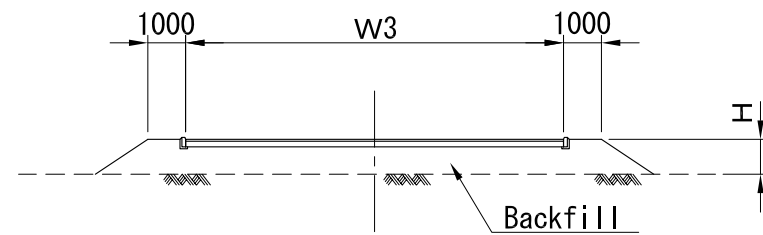

CROSS SECTION TYPE-1&2
INTERSECTION S=1:100

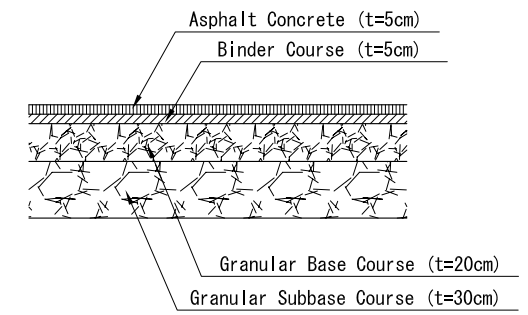

MAIN-1

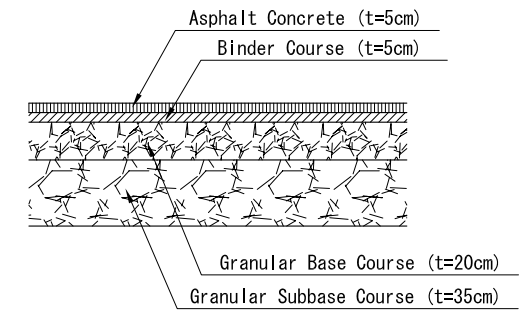

MAIN-2

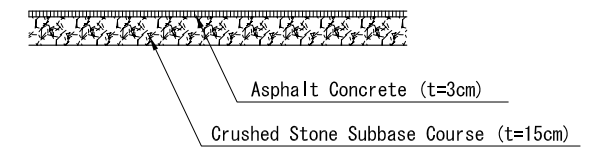

BRANCH-1

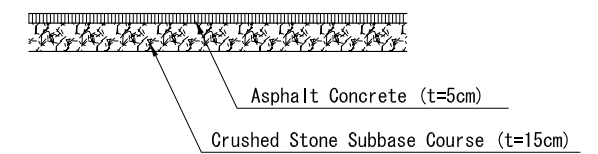

BRANCH-2

PAVEMENT SECTION S=1:20

L'OFFICE DES ROUTES
THE REPUBLIC OF BURUNDI

THE BASIC DESIGN STUDY
ON THE GRANT AID FOR REHABILITATION OF
ROADS AND INFRASTRUCTURE FOR BUJUMBURA CITY
IN THE REPUBLIC OF BURUNDI

JAPAN INTERNATIONAL COOPERATION AGENCY
CTI ENGINEERING INTERNATIONAL CO., LTD.

TITLE :
DETAILS OF INTERSECTION 1/2

SCALE
AS SHOWN

Drawing No.
M-02

LIST OF INTERSECTION (ROUTE-1)																
STA	SIDE (L/R)	TYPE	RADIUS		WIDTH			VERTICAL	LENGTH			PAVEMENT		CULVERT	REMARKS	
			(m)		(m)			INTERVAL	(m)			TYPE		(m)		
			R1	R2	W1	W2	W3	H(m)	L1	L2	L3	A1	A2&A3	B		
0+000			Refer to Intersection 1 Drawing													
0+187	L	TYPE-1	6.0	9.0	44.2	36.8	9.5	0.87	1.0	22.0	4.7	MAIN-1	BRANCH-2	0.70	BC400 × 400	
0+337	L	TYPE-1	3.0	3.0	13.6	9.1	7.6	0.42	1.0	2.0	3.0	MAIN-1	BRANCH-1	0.60	BC300 × 300	
0+454	L	TYPE-1	15.0	13.0	37.8	27.4	9.5	0.87	1.0	14.4	16.0	MAIN-1	BRANCH-2	—		
	R	TYPE-1	6.5	13.0	27.7	20.9	9.9	0.87	1.0	10.7	21.1	MAIN-1	BRANCH-2	—		
0+574	L	TYPE-1	11.0	20.0	38.0	27.2	7.0	0.71	1.0	18.8	8.3	MAIN-1	BRANCH-2	—		
0+794	L	TYPE-1	3.0	3.0	11.6	7.1	5.6	▲0.25	1.0	2.0	5.8	MAIN-1	BRANCH-1	0.60	BC300 × 300	
0+804			Refer to Intersection 2 Drawing													
0+927	L	TYPE-1	9.0	6.0	23.0	15.7	7.2	▲0.24	1.0	10.4	—	MAIN-1	BRANCH-1	0.60	BC300 × 300	
1+183	L	TYPE-1	9.0	6.0	28.2	20.0	12.0	▲0.24	1.0	9.2	—	MAIN-1	BRANCH-1	—		
1+381	L	TYPE-1	6.0	3.0	19.2	13.6	10.5	0.15	1.0	3.2	—	MAIN-1	BRANCH-2	—		
1+732	R	TYPE-1	25.0	—	37.1	17.8	10.4	0.13	1.0	2.3	14.6	MAIN-1	BRANCH-1	—		
1+859	L	TYPE-1	3.0	3.0	12.8	8.3	6.8	0.15	1.0	2.0	3.0	MAIN-1	BRANCH-1	0.60	BC300 × 300	
1+933	L	TYPE-1	3.0	3.0	12.6	8.1	6.6	0.61	1.0	2.0	7.2	MAIN-1	BRANCH-1	0.60	BC300 × 300	
2+000			Refer to Intersection 3 Drawing													
2+245	L	TYPE-2	6.0	9.0	20.9	9.0	6.0	▲0.28	3.0	4.0	9.6	MAIN-1	BRANCH-2	—		
2+359	L	TYPE-2	6.0	6.0	18.0	8.3	5.7	▲0.14	3.0	3.5	3.4	MAIN-1	BRANCH-2	—		
2+428	L	TYPE-2	6.0	6.0	18.2	7.7	5.9	0.16	3.0	4.2	—	MAIN-1	BRANCH-2	—		
	R	TYPE-2	6.0	6.0	17.5	7.2	5.0	▲0.04	3.0	5.2	—	MAIN-1	BRANCH-1	—		
2+545			Refer to Intersection Y1 Drawing													
2+659	L	TYPE-2	6.0	6.0	20.7	10.4	8.4	▲0.53	3.0	2.8	12.1	MAIN-1	BRANCH-2	—		
2+827	L	TYPE-2	6.0	6.0	20.0	9.6	8.0	0.24	3.0	2.8	2.4	MAIN-1	BRANCH-2	0.80	BC500 × 500	
2+896	L	TYPE-2	6.0	3.0	15.3	7.7	6.5	0.31	3.0	3.7	—	MAIN-1	BRANCH-2	—		
2+960	R	TYPE-2	9.0	9.0	31.7	17.9	13.4	▲0.07	3.0	6.0	—	MAIN-1	BRANCH-1	—		
2+980	L	TYPE-2	5.3	4.8	16.0	8.9	6.0	▲0.15	1.5	3.7	—	MAIN-1	BRANCH-2	—		

LIST OF INTERSECTION (ROUTE-2)																
STA	SIDE (L/R)	TYPE	RADIUS		WIDTH			VERTICAL	LENGTH			PAVEMENT		CULVERT	REMARKS	
			(m)		(m)			INTERVAL	(m)			TYPE		(m)		
			R1	R2	W1	W2	W3	H(m)	L1	L2	L3	A1	A2&A3	B		
Y0+000			Refer to Intersection Y1 Drawing													
Y0+058	R	TYPE-2	3.0	3.0	10.5	5.3	4.5	0.53	1.5	1.7	7.3	MAIN-1	BRANCH-1	0.80	BC500 × 500	
Y0+139	L	TYPE-2	6.0	6.0	19.3	10.3	7.3	0.17	3.0	3.1	7.0	MAIN-1	BRANCH-2	—		
	R	TYPE-2	6.0	6.0	19.6	10.6	7.7	0.03	3.0	3.0	—	MAIN-1	BRANCH-2	—		
Y0+395	L	TYPE-2	6.0	6.0	19.0	8.6	7.0	0.10	3.0	3.0	8.1	MAIN-1	BRANCH-2	—		
	R	TYPE-2	6.0	6.0	19.0	8.6	7.0	0.31	3.0	3.0	4.0	MAIN-1	BRANCH-2	—		
Y0+563	L	TYPE-2	6.0	6.0	20.7	10.4	8.7	0.18	3.0	3.0	3.0	MAIN-1	BRANCH-2	—		
	R	TYPE-2	6.0	6.0	19.3	8.9	7.2	0.01	3.0	3.0	5.7	MAIN-1	BRANCH-2	—		
Y0+714	L	TYPE-2	6.0	6.0	21.7	10.9	8.9	0.19	3.0	3.0	12.8	MAIN-1	BRANCH-1	—		
	R	TYPE-2	6.0	6.0	18.5	7.6	6.9	0.06	3.0	3.0	12.0	MAIN-1	BRANCH-1	—		
Y0+824	L		Refer to Intersection Y2 (NR3) Drawing													
Y1+076	L	TYPE-2	9.0	6.0	22.0	10.9	7.2	▲0.10	2.0	5.4	—	MAIN-2	BRANCH-1	0.80	BC500 × 500	
	R	TYPE-2	6.0	6.0	19.7	11.3	7.8	0.00	2.0	3.5	—	MAIN-2	BRANCH-1	0.80	BC500 × 500	
Y1+139	L	TYPE-2	3.0	6.0	15.2	7.7	5.8	▲0.67	2.0	4.5	5.0	MAIN-2	BRANCH-1	0.80	BC500 × 500	
	R	TYPE-2	9.0	6.0	21.8	12.0	7.3	0.03	2.0	6.5	—	MAIN-2	BRANCH-1	0.80	BC500 × 500	
Y1+392			Refer to Intersection Y3 Drawing													

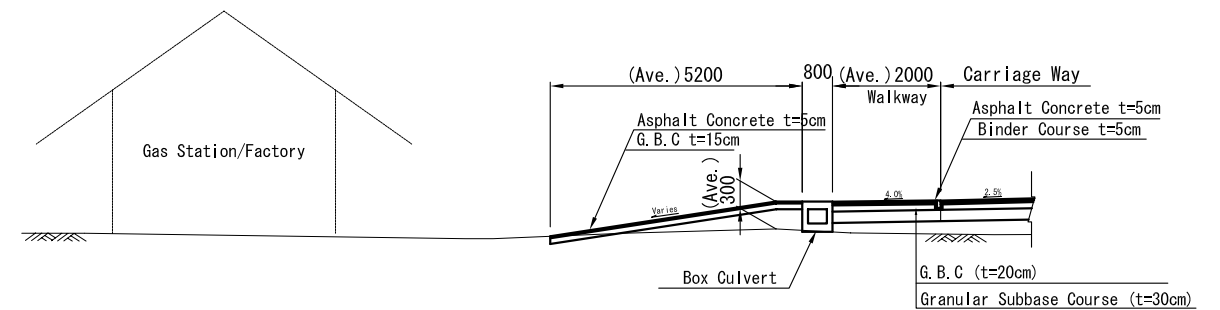
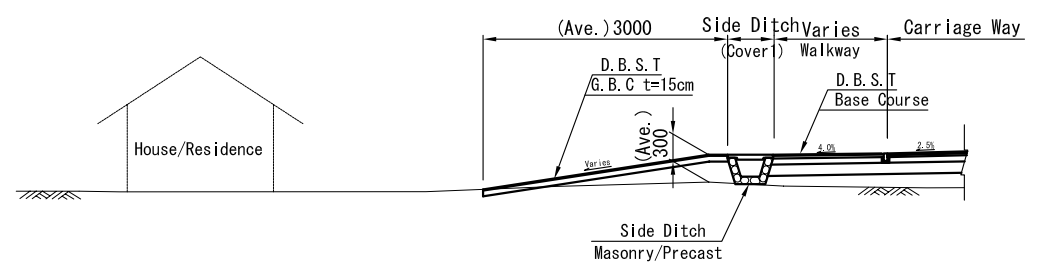
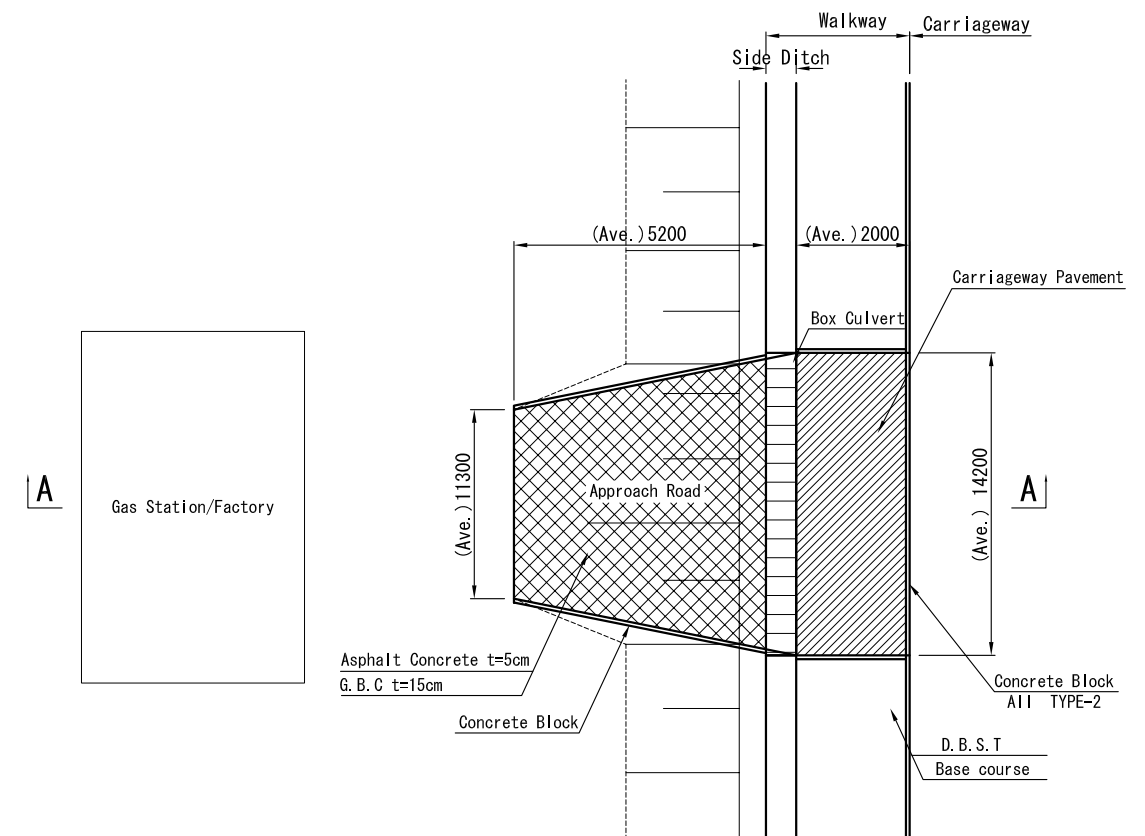
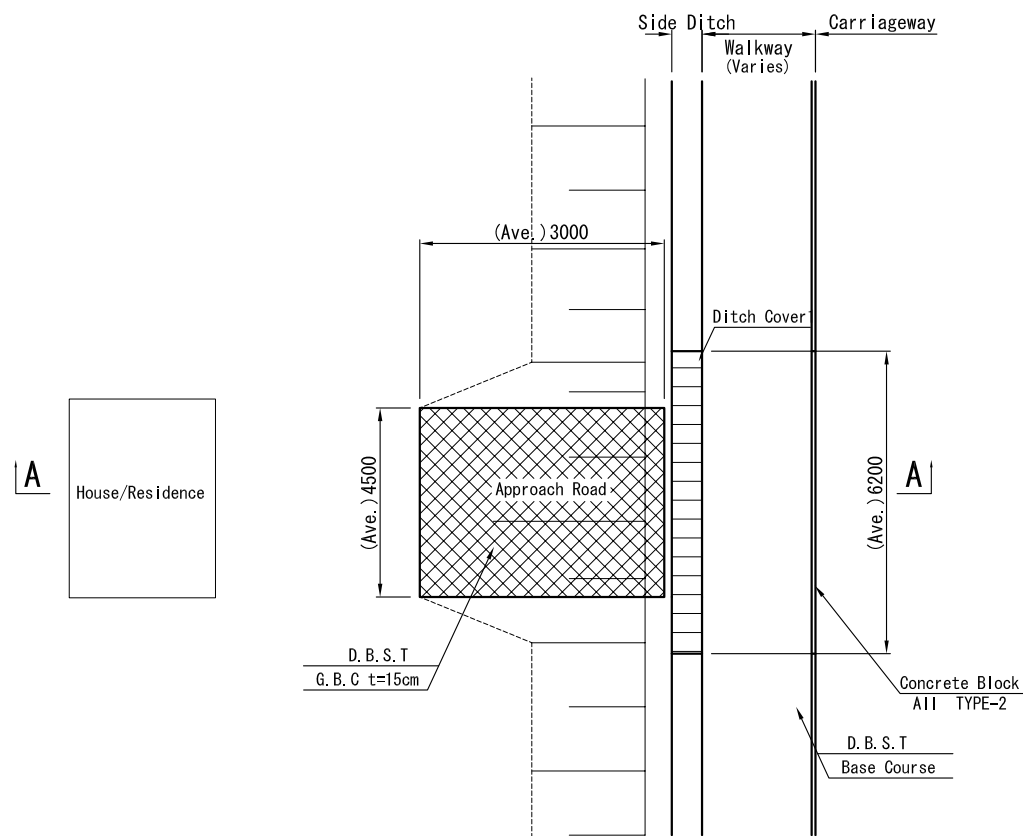

NOTE: G.B.C: Granular Base Course

NOTE: G.B.C: Granular Base Course
G.S.C: Granular Subbase Course
B.C : Box Culvert

TYPE-1 (LIGHT VEHICLES)

TYPE-2 (HEAVY VEHICLES)

HOUSE ACCESS S=1:100

L'OFFICE DES ROUTES THE REPUBLIC OF BURUNDI	THE BASIC DESIGN STUDY ON THE GRANT AID FOR REHABILITATION OF ROADS AND INFRASTRUCTURE FOR BUJUMBURA CITY IN THE REPUBLIC OF BURUNDI	JAPAN INTERNATIONAL COOPERATION AGENCY CTI ENGINEERING INTERNATIONAL CO., LTD.	TITLE : DETAILS OF HOUSE ACCESS	SCALE AS SHOWN	Drawing No. M-04
--	---	---	------------------------------------	-------------------	---------------------

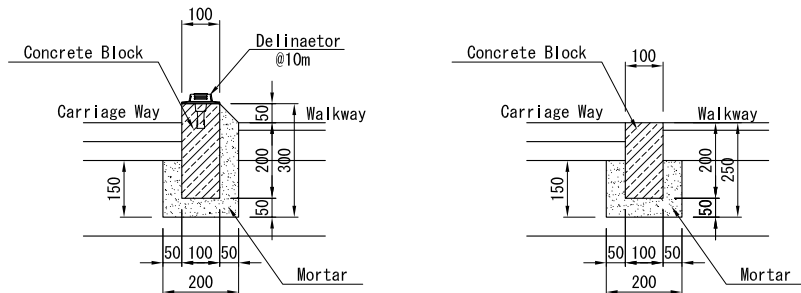

(TYPE-1)

(TYPE-2)

CURB STONE S=1:10

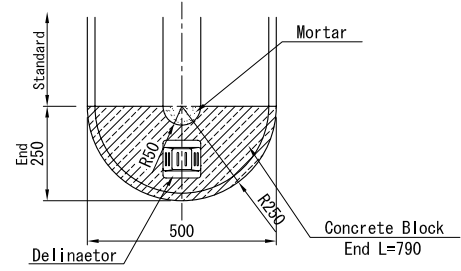

PLAN

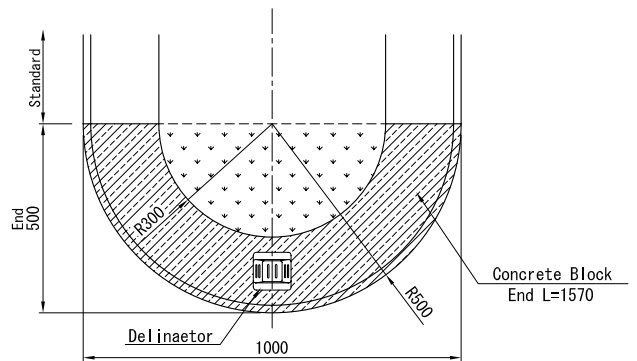

PLAN

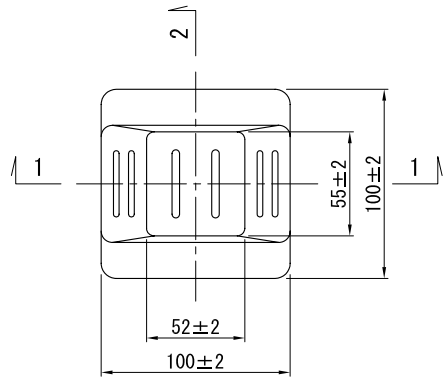

PLAN

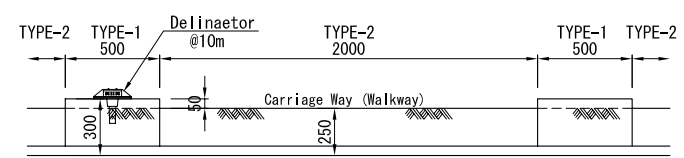

SIDE VIEW S=1:20

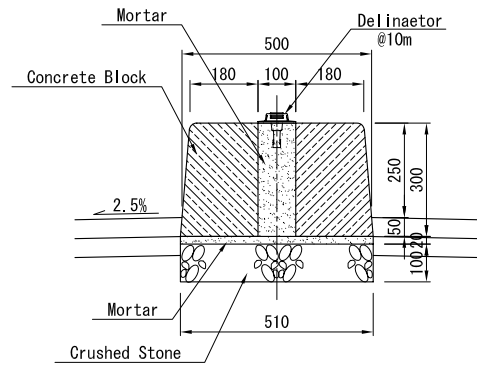

SECTION

MEDIAN (TYPE-1) S=1:10

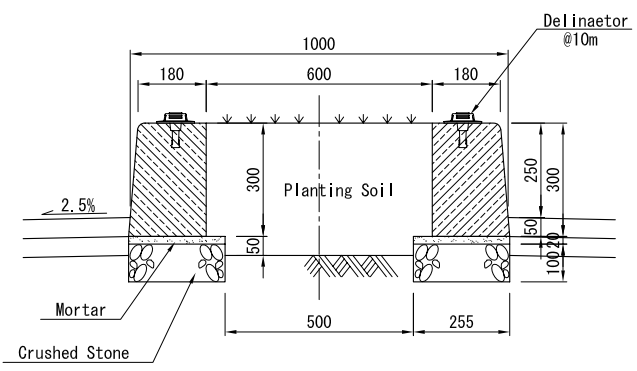

SECTION

MEDIAN (TYPE-2) S=1:10

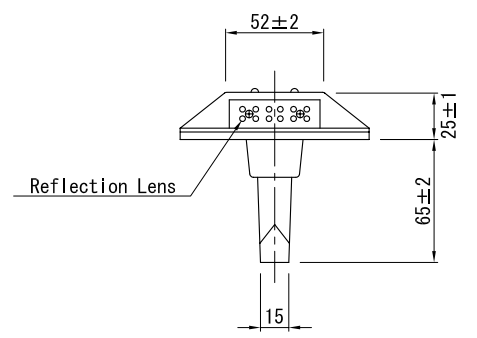

1-1 SECTION

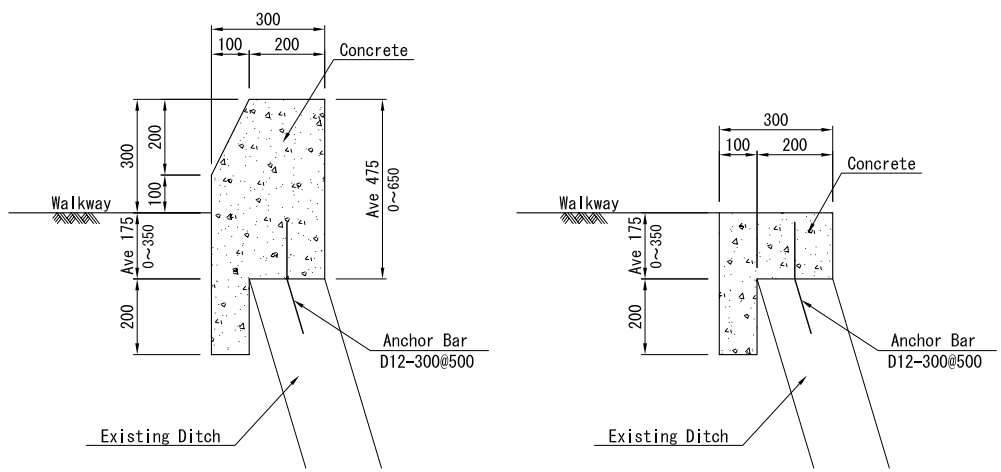

(TYPE-1)

(TYPE-2)

EDGE BLOCK S=1:10

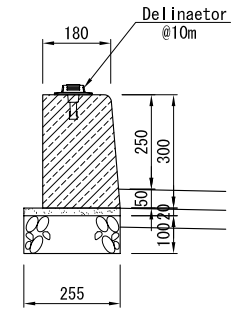

TRAFFIC ISLAND BLOCK S=1:10

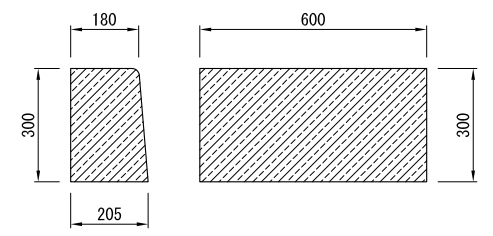

DETAIL OF CONCRETE BLOCK S=1:10

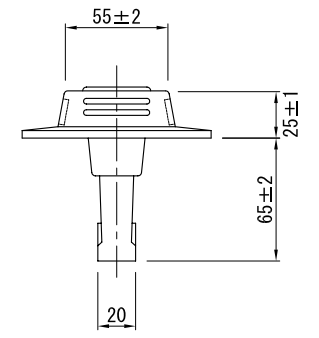

2-2 SECTION

DETAIL OF DELINAETOR S=1:2

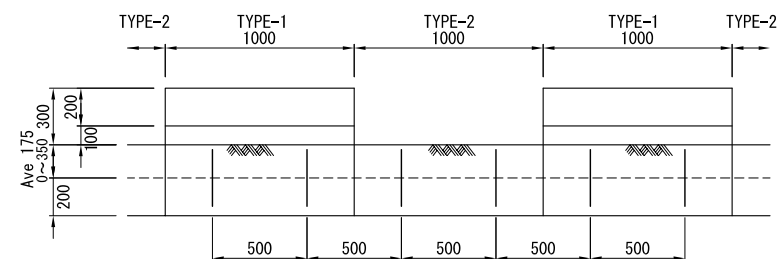

SIDE VIEW S=1:20

L'OFFICE DES ROUTES
THE REPUBLIC OF BURUNDI

THE BASIC DESIGN STUDY
ON THE GRANT AID FOR REHABILITATION OF
ROADS AND INFRASTRUCTURE FOR BUJUMBURA CITY
IN THE REPUBLIC OF BURUNDI

JAPAN INTERNATIONAL COOPERATION AGENCY
CTI ENGINEERING INTERNATIONAL CO., LTD.

TITLE :
DETAILS OF CURB STONE AND BULOCK

SCALE
AS SHOWN

Drawing No.
M-05

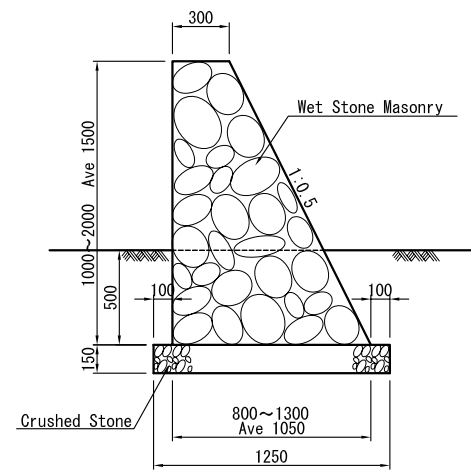

GRAVITY WALL (MASONRY) S=1:20

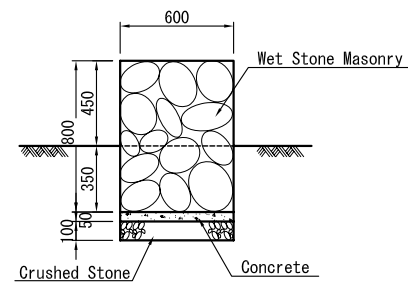

MASONRY WALL S=1:20

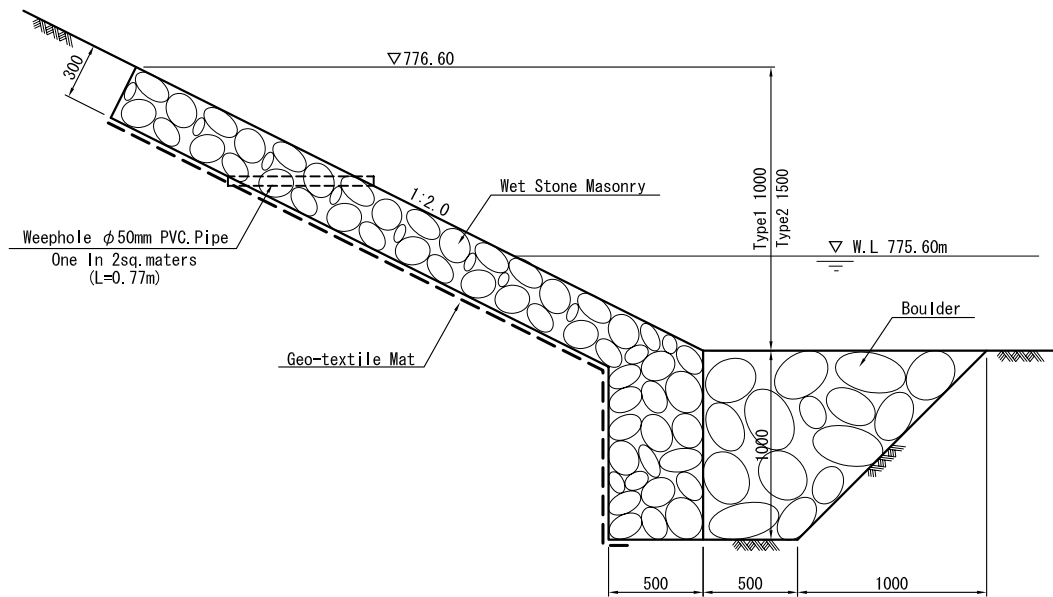

RIPRAP REVETMENT S=1:20

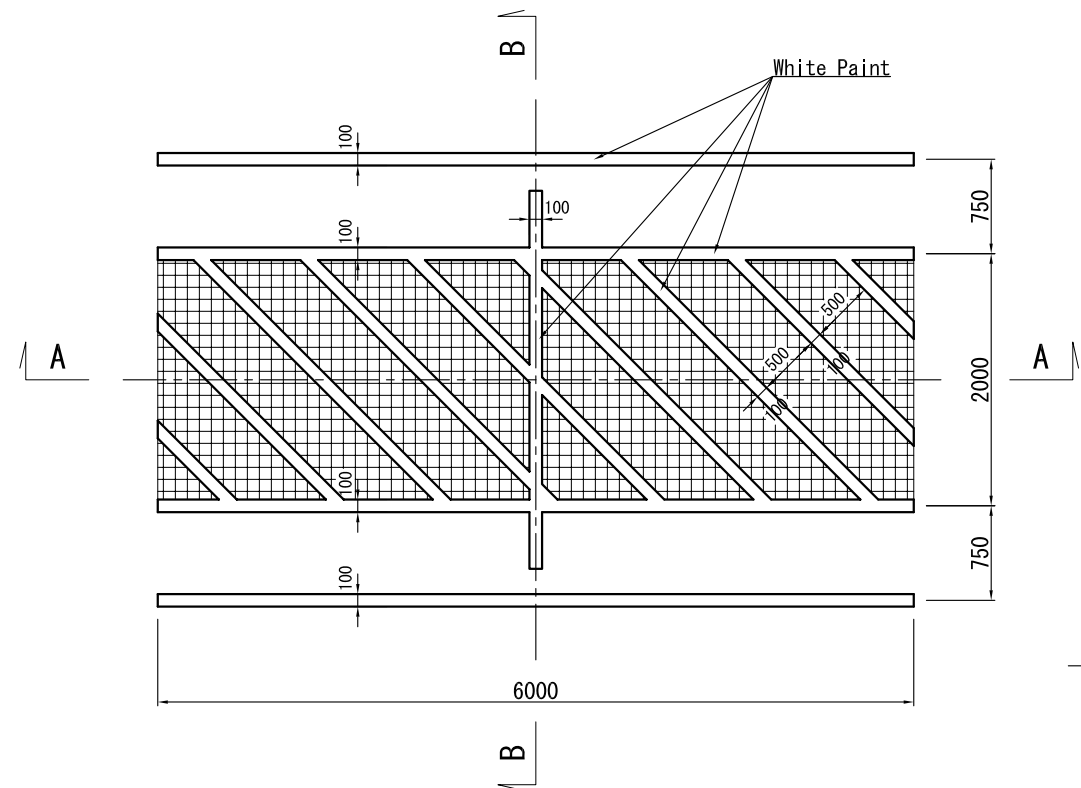

PLAN

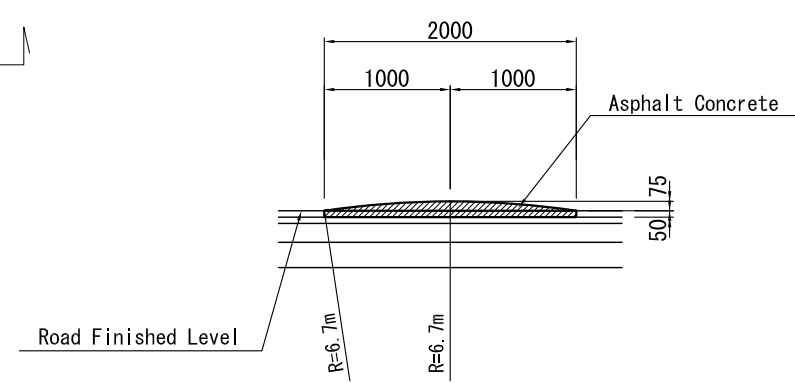

B-B SECTION

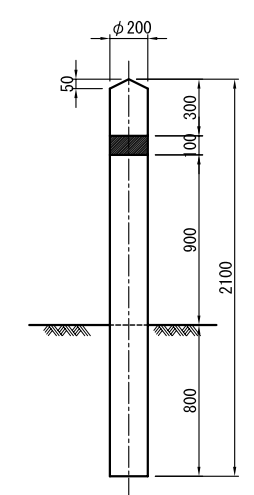

GUARD POST S=1:20

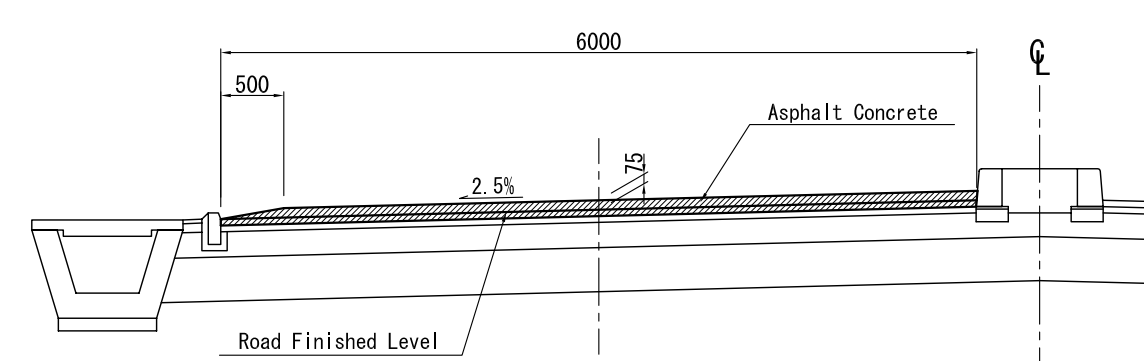

A-A SECTION

LIST OF HUMP

STATION	NUMBER	REMARKS
2+000	2	INTERSECTION 3
Y0+824	4	NR3 CROSSING
TOTAL	6	

DETAILS OF HUMP S=1:30

L'OFFICE DES ROUTES THE REPUBLIC OF BURUNDI	THE BASIC DESIGN STUDY ON THE GRANT AID FOR REHABILITATION OF ROADS AND INFRASTRUCTURE FOR BUJUMBURA CITY IN THE REPUBLIC OF BURUNDI	JAPAN INTERNATIONAL COOPERATION AGENCY CTI ENGINEERING INTERNATIONAL CO., LTD.	TITLE : DETAILS OF HUMP	SCALE	Drawing No.
				AS SHOWN	M-07

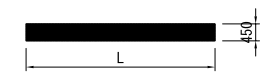
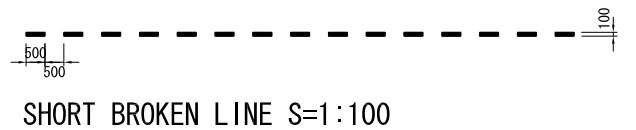
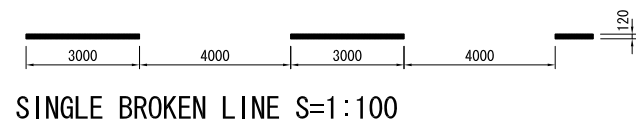
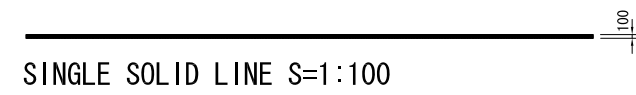

STOP LINE MARKING S=1:100

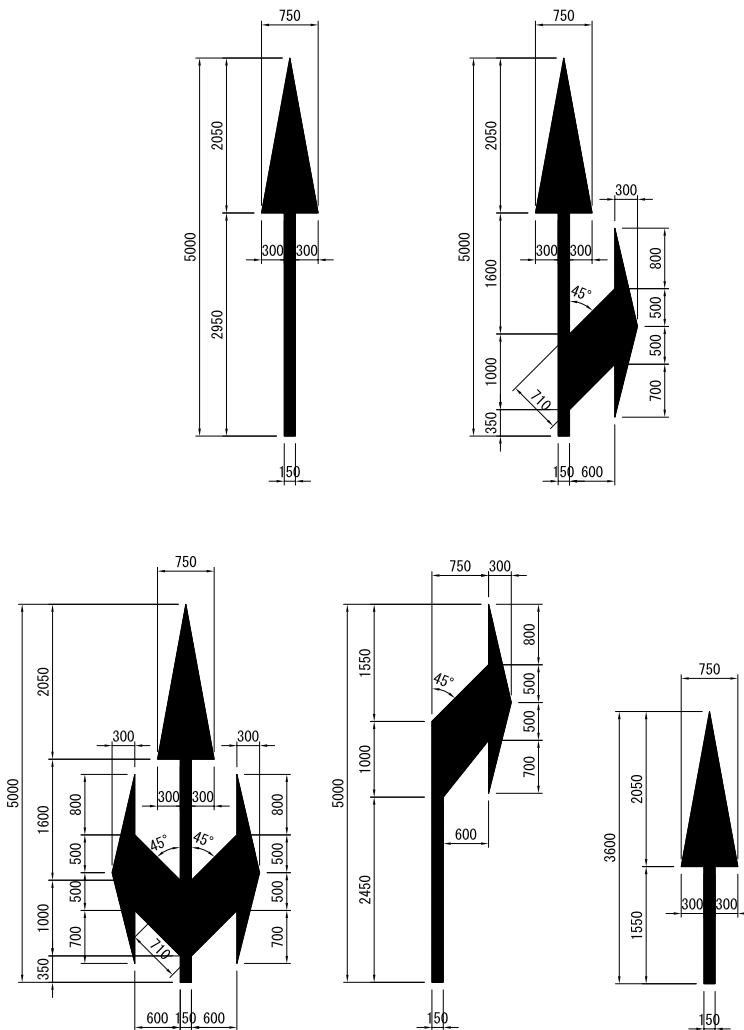

DIRECTIONAL ARROWS S=1:50

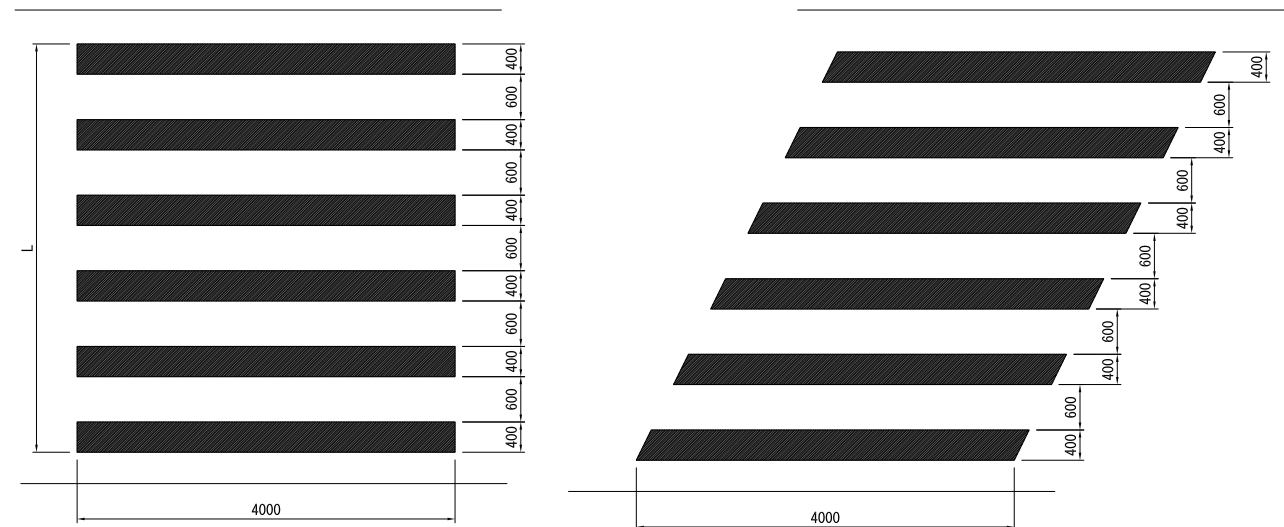

CROSS WALKS S=1:50

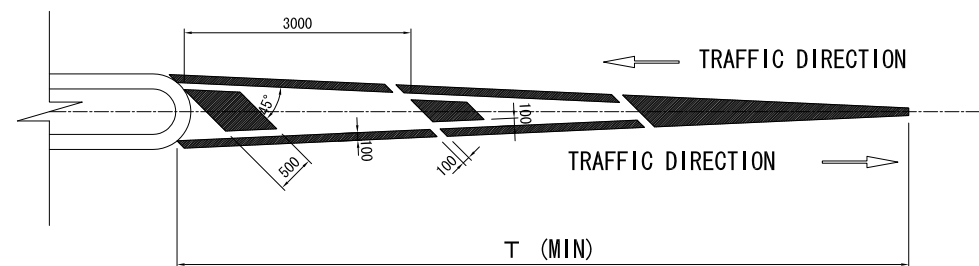

JUNCTION HATCHING MARKING S=1:50

URBAN

DESIGN SPEED (Km/h)	T (m)
20	10
30	10
40	15
50	20
60	30

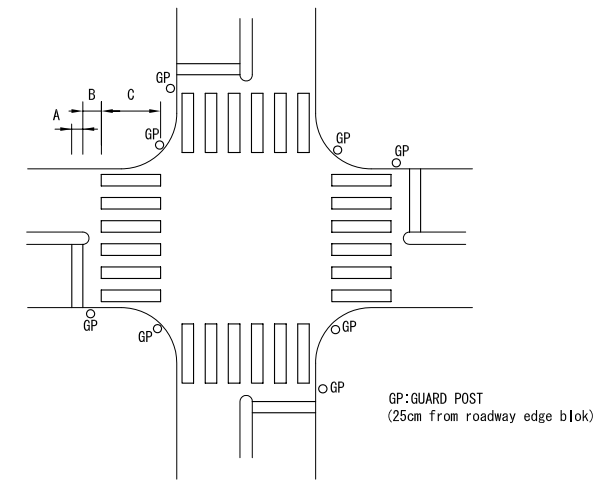

CROSS WALKS AT INTERSECTION

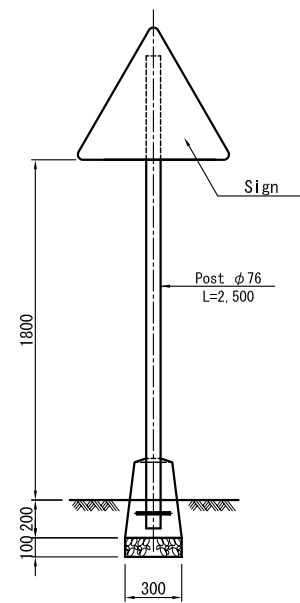
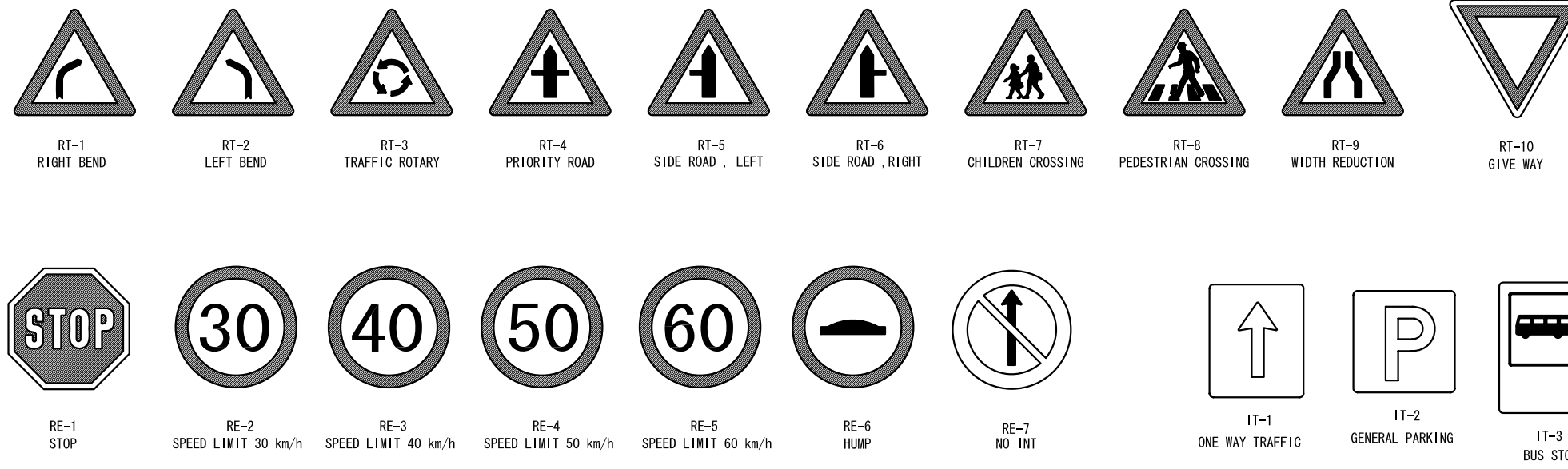

SIGN POST S=1:20

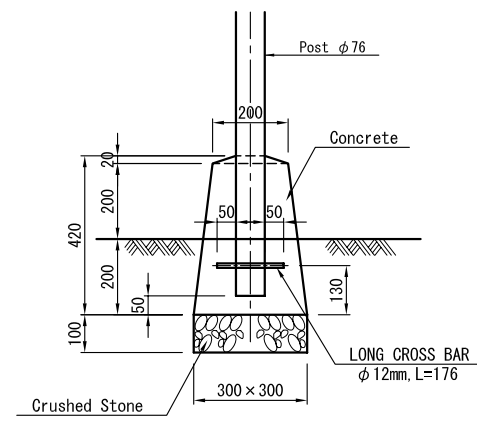

BASE S=1:10

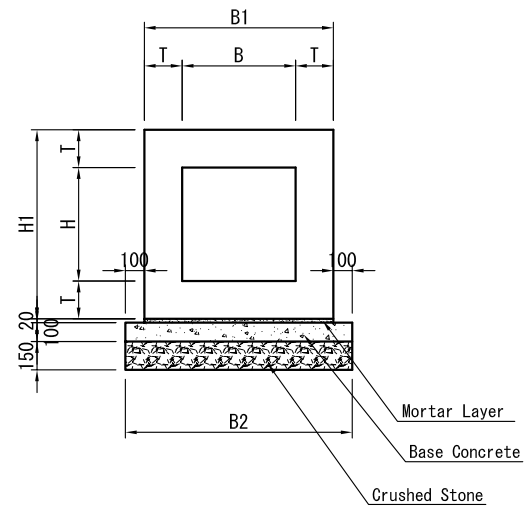

GENERAL DRAWING OF BOX CULVERT (Type1~7) S=1:20

DIMENSION TABLE

Type	B × H	B1	B2	H1	T	b1	b2	b3	n1	h1	h2	h3	n2	t
1	300 × 300	600	800	600	150	75	150	-	-	75	150	-	-	75
2	400 × 400	700	900	700	150	75	200	-	-	75	200	-	-	75
3	500 × 500	800	1000	800	150	75	250	-	-	75	250	-	-	75
4	700 × 600	1100	1300	1000	200	100	225	250	1	100	175	250	1	100
5	800 × 700	1200	1400	1100	200	100	150	500	2	100	225	250	1	100
6	900 × 700	1300	1500	1100	200	100	200	500	2	100	225	250	1	100
7	900 × 900	1300	1500	1300	200	100	200	500	2	100	200	500	2	100

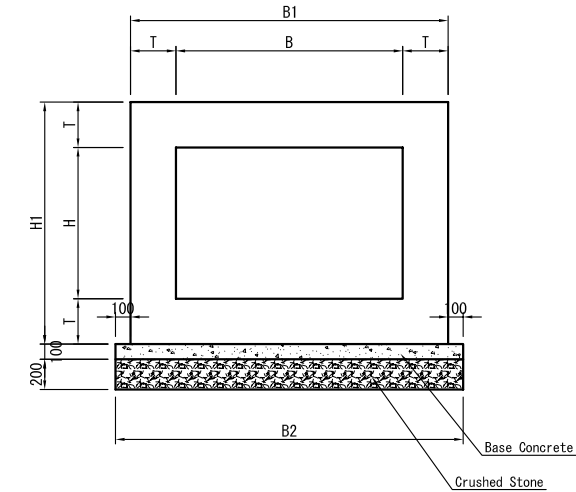

GENERAL DRAWING OF BOX CULVERT (Type8~12) S=1:25

DIMENSION TABLE

Type	B × H	B1	B2	H1	T	b1	b2	b3	n1	h1	h2	h3	n2	t
8	1000 × 600	1500	1700	1100	250	130	185	750	3	130	110	500	2	60
9	1000 × 1000	1500	1700	1500	250	130	185	750	3	130	185	750	3	60
10	1400 × 700	2000	2200	1300	300	140	155	1250	5	140	180	500	2	80
11	1500 × 1000	2100	2300	1600	300	140	205	1250	5	140	205	750	3	80
12	1500/2600 × 1000	2650	2850	1600	300	140	230	1750	7	140	205	750	3	80

※ No. 12 (1500/2600 × 1000) IS REPRESENTED BY ITS AVERAGE DIMENSIONS

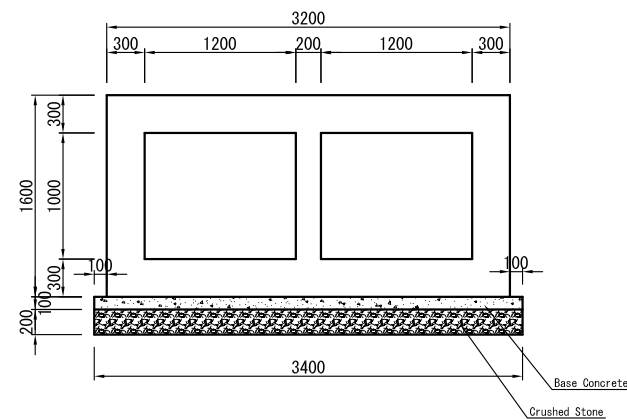

GENERAL DRAWING OF BOX CULVERT (Type13) S=1:30

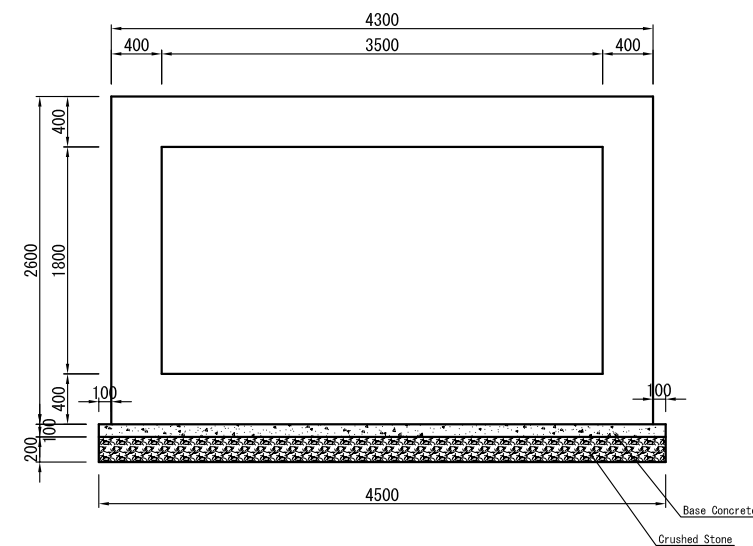

GENERAL DRAWING OF BOX CULVERT (Type14) S=1:30