

添付資料 8 気象庁（フルフレ島）による気象観測データ

Mean relative humidity Hulhule 1998 - 2008

	1998	1999	2000	2001	2002	2003	2004	2005	2006	2007	2008
Jan	79	80	79	78	80	82	79	78	82	77	82
Feb	74	80	74	76	82	81	78	76	79	74	80
Mar	73	79	76	75	78	81	79	77	78	76	80
Apr	77	79	82	80	83	82	79	79	80	78	80
May	79	82	81	81	83	82	80	80	79	82	79
Jun	79	80	81	81	82	83	80	82	80	83	79
Jul	81	79	79	80	81	83	81	80	82	80	80
Aug	79	80	81	78	83	80	79	80	80	80	82
Sep	81	78	83	82	80	81	83	83	81	82	77
Oct	79	81	82	85	82	79	82	82	78	79	79
Nov	81	78	81	81	83	84	83	83	84	76	77
Dec	82	79	77	85	83	77	81	80	84	83	78
Yearly avrg	79	80	80	80	82	81	80	80	81	79	79

Monthly rainfall total Hulhule 1998 - 2008

	1998	1999	2000	2001	2002	2003	2004	2005	2006	2007	2008
Jan	249.3	178.4	232.0	140.0	36.6	184.1	2.7	16.7	147.6	18.9	69.6
Feb	14.1	63.3	10.9	31.4	174.7	93.6	49.4	0	0	0.2	51.3
Mar	10.5	1.6	20.2	13.4	94.0	55.0	4.5	73.0	51.5	22.0	176.7
Apr	65.7	113.3	268.6	215.0	130.0	160.2	175.0	15.7	175.2	199.3	136.5
May	310.5	266.7	80.4	133.8	190.5	124.4	112.7	159.2	87.4	181.9	244.7
Jun	171.8	258.3	288.8	75.4	176.2	224.2	66.5	160.6	176.9	182.3	239.2
Jul	235.3	166.9	109.2	199.8	202.3	398.5	248.7	158.0	192.5	178.2	157.1
Aug	66.2	235.8	111.2	84.0	255.7	143.9	159.6	130.2	326.3	136.3	259.9
Sep	197.6	102.0	291.9	277.3	130.4	398.6	283.4	285.6	432.0	268.3	40.4
Oct	214.4	260.4	124.7	238.4	176.1	62.4	361.2	388.1	169.4	330.0	247.6
Nov	178.4	113.5	119.8	78.6	163.2	562.9	300.8	149.2	568.9	41.6	156.3
Dec	423.0	289.0	110.2	240.4	410.8	65.6	249.0	112.9	383.5	233.1	222.5
yearly total	2136.8	2049.2	1767.9	1727.5	2140.5	2473.4	2013.5	1649.2	2711.2	1792.1	2001.8

Monthly average Maximum temperature 1998 - 2008

	1998	1999	2000	2001	2002	2003	2004	2005	2006	2007	2008
Jan	30.9	30.0	29.9	30.3	30.7	30.1	30.9	31.2	30.4	30.7	30.2
Feb	31.3	30.5	30.1	30.5	30.8	30.9	31.3	32.0	31.0	30.8	30.8
Mar	32.2	31.2	31.1	31.6	31.3	31.5	32.0	32.3	31.5	31.5	30.8
Apr	32.6	31.0	31.2	31.4	31.6	31.9	32.1	32.6	31.8	32.0	31.2
May	32.1	30.3	31.1	31.3	31.6	31.8	31.4	32.1	31.8	31.7	31.3
Jun	31.4	30.2	30.4	30.9	30.9	31.2	31.3	31.0	31.3	31.4	31.2
Jul	30.5	30.5	30.3	30.5	30.8	31.0	30.4	31.1	31.2	31.1	30.8
Aug	30.4	30.1	30.1	30.5	30.2	30.7	30.6	31.2	31.0	31.3	30.8
Sep	30.0	30.4	29.9	30.0	30.5	30.5	30.3	30.7	30.2	30.8	31.3
Oct	30.2	29.8	30.2	29.9	30.4	31.0	30.3	30.2	30.9	30.6	30.8
Nov	29.8	30.1	30.3	30.3	30.2	30.2	30.2	30.1	30.0	30.8	30.6
Dec	29.6	29.9	30.4	30.1	29.7	30.7	30.3	30.2	29.8	30.2	30.6
Yearly avrg	<b>30.9</b>	<b>30.3</b>	<b>30.4</b>	<b>30.6</b>	<b>30.7</b>	<b>31.0</b>	<b>30.9</b>	<b>31.2</b>	<b>30.9</b>	<b>31.1</b>	<b>30.9</b>

Monthly average Minimum temperature 1998 - 2008

	1998	1999	2000	2001	2002	2003	2004	2005	2006	2007	2008
Jan	26.6	25.5	25.1	25.6	26.4	25.4	26.4	26.1	25.5	26.4	25.7
Feb	27.1	25.9	25.6	25.8	25.8	26.3	26.1	26.9	26.2	26.3	26.2
Mar	27.8	27.0	26.8	27.2	26.2	26.8	27.0	27.4	26.7	26.9	26.1
Apr	28.0	26.9	26.4	26.4	26.3	26.8	27.2	27.5	27.2	27.0	26.6
May	27.2	26.0	26.3	26.5	26.6	27.2	26.9	26.6	27.1	26.8	26.2
Jun	26.5	25.9	25.2	25.6	26.3	25.5	26.3	26.4	26.4	26.5	25.7
Jul	25.6	25.7	25.7	25.6	26.2	25.4	25.0	25.9	26.2	25.6	26.1
Aug	26.2	25.1	25.6	25.7	25.7	26.5	25.0	26.1	25.4	26.5	26.0
Sep	25.4	25.6	25.0	24.4	26.0	25.3	25.0	25.2	25.1	26.0	26.8
Oct	25.9	25.4	25.5	25.4	25.4	26.3	25.3	25.1	26.2	25.4	26.1
Nov	25.0	25.5	25.7	25.6	25.2	24.6	25.0	25.7	24.7	26.4	26.1
Dec	25.1	25.1	26.0	25.2	25.1	25.9	25.5	25.7	25.0	25.3	25.8
Yearly avrg	<b>26.4</b>	<b>25.8</b>	<b>25.7</b>	<b>25.8</b>	<b>25.9</b>	<b>26.0</b>	<b>25.9</b>	<b>26.2</b>	<b>26.0</b>	<b>26.2</b>	<b>26.1</b>

Monthly average temperature 1998 - 2008

	1998	1999	2000	2001	2002	2003	2004	2005	2006	2007	2008
Jan	28.8	27.6	27.6	28.1	28.5	27.9	28.5	28.5	27.9	28.3	27.8
Feb	29.1	28.4	27.9	28.4	28.5	28.6	28.7	29.2	28.5	28.3	28.5
Mar	29.9	29.0	28.9	29.4	29.0	29.3	29.5	29.7	29.1	29.1	28.5
Apr	30.4	28.9	29.1	29.1	29.2	29.6	29.7	29.9	29.7	29.5	28.9
May	29.9	28.4	29.1	29.1	29.4	29.8	29.5	29.5	29.6	29.4	28.9
Jun	29.4	28.2	28.4	29.0	28.9	28.9	29.1	28.9	29.0	29.2	28.8
Jul	28.6	28.2	28.2	28.5	28.8	28.7	27.9	28.7	28.8	28.6	28.6
Aug	28.6	27.9	28.0	28.6	28.3	28.8	28.3	28.9	28.4	29.1	28.5
Sep	28.1	28.4	27.8	27.9	28.5	28.3	28.0	28.2	28.1	28.7	29.0
Oct	28.1	27.9	28.2	28.0	28.3	28.6	28.0	28.1	28.5	28.3	28.5
Nov	27.7	27.8	28.2	28.1	27.9	27.4	27.8	27.9	27.6	28.5	28.4
Dec	27.2	27.7	28.2	27.9	27.5	28.3	28.0	28.0	27.6	27.9	28.2
Yearly avrg	<b>28.8</b>	<b>28.2</b>	<b>28.3</b>	<b>28.5</b>	<b>28.6</b>	<b>28.7</b>	<b>28.6</b>	<b>28.8</b>	<b>28.6</b>	<b>28.7</b>	<b>28.5</b>

Monthly total hrs of sunshine Hulhule 1998 - 2008

	1998	1999	2000	2001	2002	2003	2004	2005	2006	2007	2008
Jan	251.4	200.7	228.3	236.7	251.5	245.3	272.9	269.2	243.7	266.7	245.5
Feb	276.3	259.4	279.6	268.3	248.9	266.1	279.9	278.3	259.3	283.0	265.5
Mar	307.9	270.4	275.7	318.9	268.4	276.6	314.7	297.8	276.2	299.8	234.2
Apr	291.4	236.7	245.4	232.5	219.1	233.4	265.0	275.7	293.3	277.4	208.4
May	208.5	194.2	242.3	224.8	253.2	228.7	229.4	232.5	243.2	247.4	269.1
Jun	184.6	231.0	168.8	225.4	208.8	151.5	270.0	221.2	212.6	200.9	219.6
Jul	197.0	230.9	244.1	230.5	247.0	203.4	163.1	218.2	232.4	216.7	194.4
Aug	259.4	219.8	217.4	260.2	237.1	272.4	240.3	259.3	189.2	234.2	223.9
Sep	194.3	210.3	171.7	182.4	254.3	202.1	174.0	196.0	181.6	185.1	295.3
Oct	240.1	211.9	261.3	225.3	234.0	301.5	231.5	220.3	250.4	197.0	207.5
Nov	267.4	255.3	207.7	224.9	149.9	152.9	171.9	244.5	127.9	266.3	223.7
Dec	148.1	219.4	273.9	226.4	168.4	269.8	196.8	250.1	119.2	200.0	234.6
Yearly avrg	<b>235.5</b>	<b>228.3</b>	<b>234.7</b>	<b>238.0</b>	<b>228.4</b>	<b>233.6</b>	<b>234.1</b>	<b>246.9</b>	<b>219.1</b>	<b>239.5</b>	<b>235.1</b>

Monthly average wind speed (knots) Hulhuile 1998 - 2008

	1998	1999	2000	2001	2002	2003	2004	2005	2006	2007	2008
Jan	14	10	11	10	11	12	12	9	11	14	9
Feb	10	9	6	6	11	9	8	11	10	10	7
Mar	8	6	6	6	8	7	7	9	7	7	8
Apr	6	12	10	7	5	5	6	6	8	6	8
May	10	12	10	11	10	10	14	9	10	10	9
Jun	12	9	12	11	12	9	10	10	10	8	8
Jul	13	9	10	11	11	7	10	9	8	9	10
Aug	11	7	10	10	10	10	8	7	7	7	8
Sep	13	9	10	10	8	9	9	9	10	9	8
Oct	10	15	10	12	11	10	6	13	6	12	9
Nov	11	5	8	8	7	7	7	9	7	6	7
Dec	8	10	9	11	9	10	11	11	13	10	9
Yearly avrg	11	9	9	10	9	9	9	9	9	9	8

## Report on Field Survey of PV-Diesel Hybrid System in Mandhoo Island

### 1. Date

May 19, 2009 (1 day)

### 2. Schedule

8:30 – 11:30 Transportation by Boat

11:30 – 15:30 Field Survey

15:30 – 17:30 Transportation by Boat

### 3. Members

Name	Organization
JICA Study Team	
Mr. Tadayuki Ogawa	Team Leader
Mr. Fumikazu Doi	JICA Expert: Grid-connected PV system
Mr. Makoto Abe	Coordinator
MHTE	
Mr. Mohamed Fazeeh	Electrical Engineer
STELCO	
Mr. Ibrahim Nizam	Electrical Engineer

### 4. Purpose of the Field Survey

The first PV-Diesel hybrid system has been installed at Mandhoo Island in 2005 as a collaboration pilot project between SMILES<sup>1</sup> and RETDAP<sup>2</sup>. In order to monitor the present condition of management, operation and maintenance of the system, JICA Study Team conducted the field survey in cooperation with MHTE and STELCO.

### 5. Outline of the Project

Mandhoo Island is located about 100 km South-West of capital Male' in the South Ari Atoll. The island is inhabited by 68 families (373 persons). Before the project, the islands had two diesel generators that were provided by the Ministry of Atolls Development. In order to reduce the fossil fuel consumption, the PV-Diesel system with storage battery has been investigated under the project. The system was designed as a changeover system between PV/Battery system and the diesel generators including the existing generators. (Figure 1)

The PV and diesel generator could not be operated at the same time.

---

<sup>1</sup> Strengthening Maldivian Initiatives for a Long-term Energy Strategy project funded by the French Agency for the Environment and Energy Management (ADEME) and the Utrecht Energy Research of the Netherlands

<sup>2</sup> Renewable Energy Technology Development and Application Project funded by Global Environment Facility (GEF) and United Nations Development Programme (UNDP)

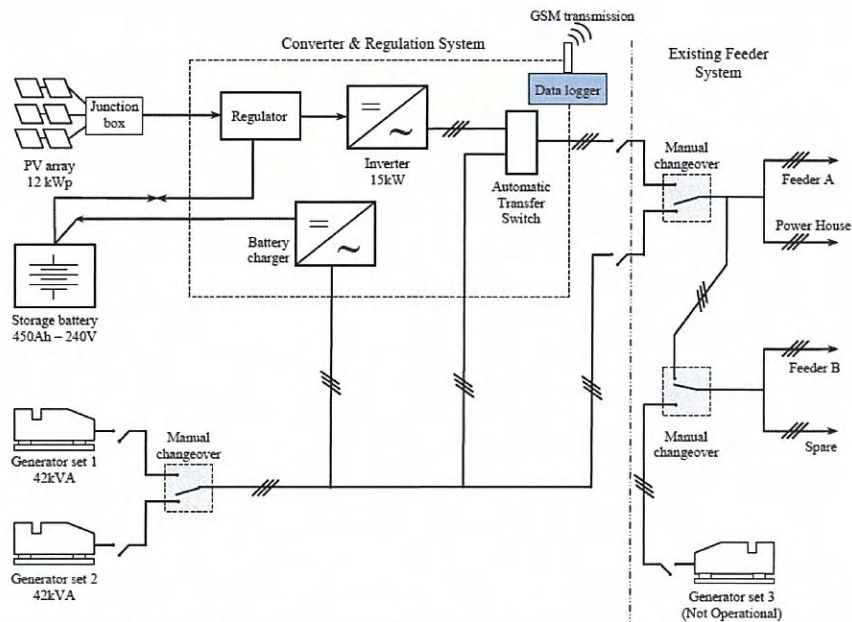

Figure 1: PV and Diesel Hybrid System Introduced in Mandhoo Island

After the completion of the project, the power demand has increased gradually and has tended to over the PV output. Therefore, the storage battery could not be charged enough during daytime. It has resulted in charging by the diesel generator.

In response to this situation, the MEEW (present MHTe) decided to disconnect the battery bank from system and to install a grid-connected type of inverter instead of the converter and regulation system last year. (Fig 2)

The PV and diesel can be operated synchronously. However the PV does not have the stand-alone function. Therefore the PV can not be operated without diesel generator.

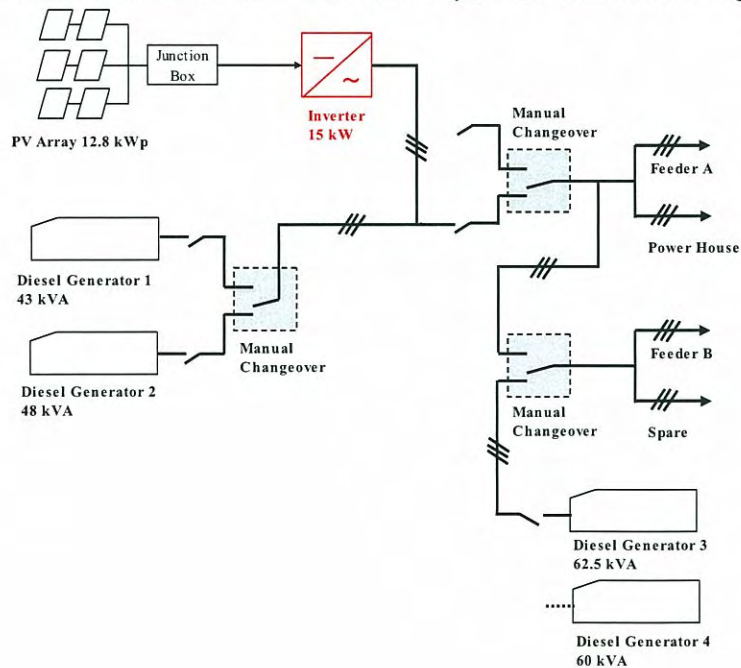

Figure 2: Present PV and Diesel Hybrid System Introduced in Mandhoo Island

## 6. Findings

### 1) Technical Aspect

- ✓ The appearance of PV modules (160 pieces, 80 Wp, BP Solar) is good condition.
- ✓ All diesel generators are maintained well. (ex. cleaning, changing filters, oil and lubricant, etc.)
- ✓ Connection cables for the new inverter are extended or jumped from existing cables. Several parts are thinner than the existing cables. It might cause the over current and/or voltage drop.
- ✓ Battery bank is left without charging. Although the condition seems to be good from the appearance, it causes the sulfation and stratification of the batteries. It results in shorten of the battery life.
- ✓ According to the operator, the peak load is approx. 25 kW in daytime and approx. 35 kW in nighttime. On the condition that PV generates well but demand is low, the diesel load factor will be low. It might affect the efficiency and engine life.

### 2) Management Aspect

- ✓ The system is managed by the Island Community. The community covers the works in accordance with the island development program including cleaning and operation of power house, etc.
- ✓ There is only one operator and his salary is 2,000 Rf/month. His main job is operation and maintenance of diesel generators. He refill the fuel several times a day and switches diesel generators every twelve (12) hours. The small diesel generator is operated during daytime (6 a.m. - 6 p.m.) and large one is operated during night time (6 p.m. – 6 a.m.). He changes consumables such as oil and filters.
- ✓ There is an area where the Hilton resort staff live. The power supply is different from the local area. The resort donated all existing diesel generators. In addition they assist the big maintenance of diesel generator such as overhaul.
- ✓ Most of island people work in the resort. They have many electrical appliances (lightings, fans, TV, iron, etc.)
- ✓ Present tariff is 3.5 Rf/kWh, fix rate even though it was 5 Rf/kWh several years ago. Main reason of decrease the tariff is reflection of fuel price.
- ✓ The community has bank account and their income from electricity is 60,000 – 70,000 Rf/month. The present fuel price is 7.75 Rf/liter. The main expenses are approx. 40,000 Rf/month for the fuel and 5,000 Rf/month for the consumables.
- ✓ The staff of island office collects the electric charge.
- ✓ PV system is owned by government.
- ✓ The power demand will increase gradually because new housings and mosque are

constructing now.

#### 7. Comments/Suggestion/Conclusion

- ✓ As for battery bank, the floating charging is required to prolong its life. It is better to utilize them for the emergency purpose or to transfer them to another island.
- ✓ As for cable size, it is better to check the capacity and to change into proper size depending on the necessity.
- ✓ By appearance, inverters showing the operation status of PV will be preferred. Now the operator is not aware how to open the inverter panel.
- ✓ Technical transfer from present operator to possible future successor is necessary because there is no person who takes over him.
- ✓ Either MHTE or STELCO will have to monitor the system and assist the island community. Periodical reporting and monitoring system may have to be considered.
- ✓ In order to analyze and evaluate the economy and efficiency of the system, it is recommendable to record the operation data such as load curve, fuel consumption and maintenance record.



Photos



PV Array

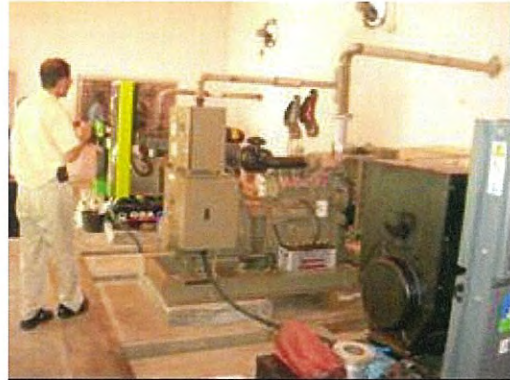

Diesel Generators



Battery Bank



Generator Control and Distribution Panels



Ex and present inverter



User's House



Operator



Main Street

添付資料 10 地方環礁島 (Fanadhoo and Gan Islands) での  
太陽光発電システム運用状況調査結果

Report on Field Survey of PV Systems in Gan and Fonadhoo Islands in Laamu Atoll

1. Date

May 28-29, 2009 (2 day)

2. Schedule

28th

15:00 – 16:00 Transportation by Airplane

29th

9:30 – 18:30 Field Survey (Gan and Fonadhoo Islands)

20:30 – 21:30 Transportation by Airplane

3. Members

Name	Organization
<b>JICA Study Team</b>	
Mr. Tadayuki Ogawa	Team Leader
Mr. Yoshitetsu Fujisawa	JICA Expert: Institutional Framework for PV Grid-connection/DSM
Mr. Tomonori Kondo	Equipment Planning/Detail Design
Mr. Makoto Abe	Coordinator
<b>MHTE</b>	
Mr. Mohamed Fazeeh	Electrical Engineer

4. List of Contact persons regarding the survey

Name	Organization	Contact
<b>Atoll Office</b>		
Mr. Abdul Wahab	Atoll Counselor	7785381
Mr. Mohamed Shifau	Administrative officer	7783462
<b>Island Office, Fanadhoo</b>		
Ibrahim Mohamed	Island Chief	7601897
<b>Power House, Fanadhoo Island</b>		
Mr. Abdul Rasheed	Operator, Power House	7934985
<b>Power House, Gan Island</b>		
Mr. Ahmed Shkeef	Operator, Power House	7798133
<b>Horizon Fisheries L. Mandhoo</b>		
Mr. Mahamed Nasym	Supervisor	7793644



## 5. Purpose of the Field Survey

The PV systems have been installed at Gan and Fonadhoo Islands in November 2006 as an emergency development study in response to the the Tsunami disaster caused by Sumatra earthquake. In order to monitor the present condition of management, operation and maintenance of these systems, JICA Study Team conducted the field survey in cooperation with MHTE.

## 6. Outline of the Project

Gan and Fonafhoo Islands in Laamu Atoll are located about 250 km away from capital Male in the South Ari Atoll. The reconstruction of administrative facilities was conducted in order to support the reconstruction of public infrastructure in these islands and PV systems were installed into Multi-purpose Building and Island Office. These PV systems are connected to the existing 400/230 V low voltage distribution line and power supply for emergency loads (communication system and minimum lightings) can be continued in the event of distribution line fault. (Figure 1)

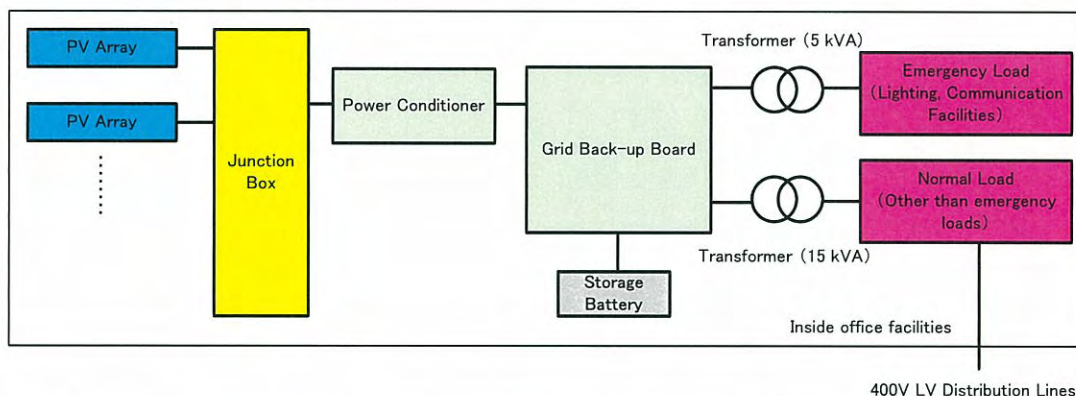

No.	Name of Equipment	Multi-Purpose Building	Island Office
1	Solar array (175 W)	11.2 kW	5.6 kW
2	Power conditioner	10 kW	10 kW
3	Grid backup board	1 set	1 set
4	Storage battery	288V 220Ah	288V 100Ah
5	Transformer	15kVA and 5kVA	15kVA and 5kVA

Source : Study Team

Figure 1: The Block Diagram and the Specifications of the PV Systems Installed into Gan and Fonadhoo Islands

---

---

## 7. Findings

### Multi-Purpose Building in Gan Island

#### 1) Technical Aspect

- ✓ The appearance of PV modules is good condition.
- ✓ The Battery condition seems to be good from the appearance,
- ✓ According to the administrative staff, these facilities have worked well since they were installed in 2006.
- ✓ Output of PV seemed to be consumed by indoor consumption mainly and the remaining seemed to be charged into Battery or sent to the existing grid.

#### 2) Management Aspect

- ✓ This system is owned by the Multi-purpose Building.
- ✓ The system is managed by the Multi-Purpose Building as one of facilities installed into that building. Therefore, the workers in the office also are in charge of O&M of PV system.
- ✓ However, they don't maintain PV system periodically. Instead, technical staffs from power house visit the site, but are not aware how to check the operating condition of PV system.
- ✓ The Excess output from PV system is sent to the existing grid, however, it was not controlled and the excess was sent free.
- ✓ The workers in charge of O&M don't know how to measure the amount of excess power from PV system to the existing grid, therefore, JICA Study Team provided necessary instruction for them.
- ✓ This building was constructed in the same time as installation of PV system, therefore, the reduction of electric tariff by PV system was not measured.
- ✓ The replacement cost of battery system was not collected yet. The cost of replacement of battery is most expensive, therefore, to save money for replacement of Battery was recommended by JICA Study Team.

### Island Office in Fonaldoo Island

#### 1) Technical Aspect

- ✓ The appearance of PV modules is good condition.
- ✓ The Battery condition seems to be good from the appearance,
- ✓ According to the administrative staff, these facilities have worked well since they were installed in 2006.
- ✓ Output of PV seemed to be consumed by indoor consumption mainly and the remaining seemed to be charged into Battery or sent to the existing grid.

---

---

## 2) Management Aspect

- ✓ This system is owned by the Island Office.
- ✓ The system is managed by the Island Office as one of facilities installed into that building. Therefore, The workers in that office also are in charge of O&M of PV system.
- ✓ However, they don't maintain PV system periodically. Instead, technical staffs from power house visit the site, but are not aware how to check the operating condition of PV system.
- ✓ The Excess output from PV system is sent to the existing grid, however, it was not controlled and the excess was sent free.
- ✓ The workers in charge of O&M don't know how to measure the amount of excess power from PV system to the existing grid, therefore, we instructed them.
- ✓ This building was constructed in the same time as installation of PV system, therefore, the reduction of electric tariff by PV system was not measured.
- ✓ The replacement cost of battery was not collected yet. The cost of replacement of battery is most expensive, therefore, to save money for replacement of Battery was recommended by JICA Study Team.

## 8. Comments/Suggestion/Conclusion (for both sites)

- ✓ To make the workers in charge of O&M maintain periodically and measure the meters periodically.
- ✓ To save money for the Replacement of Battery should be recommended by the Central Government.
- ✓ Either MHTE or STELCO will have to monitor the system and assist the Multi-Purpose Building and the Island Office. Periodical reporting and monitoring system may have to be considered.
- ✓ In order to analyze and evaluate the economy and efficiency of the system, it is recommendable to record the operation data such as load curve, fuel consumption and maintenance record.



---

---

## Photos

### Multi-Purpose Building



PV Array

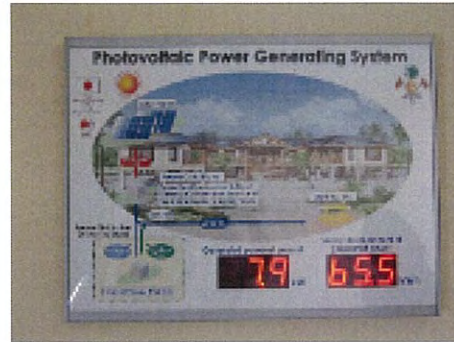

Board



Battery Bank



Meters

### Island Office



PV Array



Board



Battery Bank

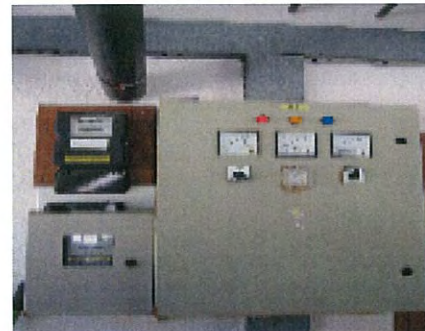

Meters