



The Project for Improvement of Management Capacity of
Operation and Maintenance for SHAPWASCO (Phase-2)

Minutes of Meeting for 9th Project Team Meeting for PH-2
MM-PTM2-9 [07.8.22]

| | | |
|------------|---|---|
| Date | 22 nd August (Wednesday) 2007 | Signature |
| Time | 10:15~10:45 | |
| Place | SHAPWASCO chairman's room | |
| Attendants | [SHAPWASCO : C/P] Eng. Alae El Din Mohamed : Head of UFW/HQ Team |  |
| | [Expert Team : The team] Mr. Masatoshi Seno : UFW Reduction Mr. Noboru Sasaki : SOP Activity Mr. Keizo Kimura : SOP Activity Mr. Mitsuhiro Omori : Network Hydraulic Analysis Dr. Ashraf A. Ahmed : Electric Mr. Mohamed Nagi : Facilitator |  |

1. General

The team reported to C/P that following expert arrived on 18th of August 2007.

Mr. Keizo Kimura : Water Treatment-2/Mechanical Engineer, Expert for SOP activity

2. UFW reduction activity (progress of last week and issues to be addressed)

The team and UFW/HQ team confirmed the progress in last week and actions for the issues raised in the meeting as follows:

2-1. Progress

Actions U2, U3, U4, U9 and U11 have been conducted in the last week and summarized with the progress and the issues to be addressed as follows,

- (1) **Action U2** Conducting leakage (or MNF) survey for candidate sites
- MNF survey for Area-5 of Diarb Nigm has been conducted according to the following conditions:
 - 1) Since the underground water level is extremely high in the excavated holes for installing the flow meter, the sensor of the flow meter will be submerged in water. Therefore, the site for Area-5 of Diarb Nigm was changed from the previous area of "Taha El Marg" to new area of "El Sania" in consultation with C/P.
 - 2) Numbers of house connection is about 850.

MM-PTM2-9 (3/4)

(10.8m³/hr). The leakage was repaired on 20th of August, immediately.

- Leakage detection survey has been continued in Area-4 and Area-1 of Zagazig City East in this week.

2-2. Schedule for this week

Above activity will be continued this week.

3. SOP activity (progress of last week and issues to be addressed)

3-1. Progress

Actions S1, S2, S3, S4, S5, S9 and S10 have been conducted currently and summarized with the issues to be addressed as follows,

- (1) **Action S1** Basic System Drawings
- Three sets of electric single-line diagrams (draft base) of the model facilities were provided to each facility at the Workshop on 21st.
 - SHAPWASCO prepared to appoint a few employees for CAD operators but they need to be trained.
 - Training of the new employ shall be considered.
 - ▲ C/P stated that SHPWASCO is proceeding with the employment of young engineers for the deployment from September 1st and some of them will be assigned as CAD operators but training of these engineers is not prepared.
- (2) **Action S2** Preparation of Unified Forms of O & M Records and Reports
- Issues for implementation of unified forms of O & M Records were discussed in the Workshop on 20th of August and required hardware upgrading will be submitted from the facilities in writing.
 - Budget allocation shall be considered in Urgent Water Supply Improvement Project.
 - ▲ C/P stated that SHPWASCO consider application of the budget from Urgent Water Supply Improvement Project by HCWW.
- (3) **Action S3** Measurement/records of Raw and Treated Water Volume at Seven WTPs
- Contractors of chamber construction/installation contracts for the first five flow meters in Abbasa WTP were determined by SHAPWASCO and field construction work will be started soon.
 - Schedule of implementation of the installation work and measurements by SHAPWASCO shall be clarified.
 - ▲ C/P stated that SHPWASCO will make contract with the civil contractor in these days and finalize construction schedule.
- (4) **Action S4** Development of SOPs for Model Facilities

- Remaining MNF survey are Area-1 & 2 of Zagazig City-West where the permission for cutting new asphalt road is necessary.
 - The letter requesting to issue the permission for cutting new asphalt road in Area 1 and 2 of Zagazig City-West has submitted to the Governorate last week. The date expecting the permission shall be confirmed.
 - ▲ C/P will follow this matter to obtain the permission as soon as possible.

- (2) **Action U3** Determining pilot project site for each pilot project area
- Although Area-4 in Zagazig City-East has been selected as the pilot project area at 7th PTM held on 7th of August, 2007, about 450 pieces of non working water meters shall be replaced. Since SHAPWASCO will replace the non working water meters by using the stock of the water meters, the number of replacement shall be minimized. Then, Team and C/P continue to survey the numbers of non working water meters in the five (5) candidate pilot project areas of Zagazig City-East and will select the adequate pilot area. At this stage, number of non working water meters is expected to be minimum in Area-1.
- (3) **Action U4** Preparing GIS drawings
- The draft of GIS drawings of Area-1 and 2 in Hihya City was delivered on 14th of August to Hihya water network section for check and the person in charge in Hihya continues to check.
 - The inputting works for GIS for Zagazig City-West were begun last week.
 - Total three trainees have joined in GIS training from last week.
- (4) **Action U9** Leakage (MNF) survey
- MNF survey for Area-1 of Zagazig City East has been conducted prior to the leakage detection survey on 18th of August, 2007.
- (5) **Action U11** Conducting leakage detection survey
- Leakage detection survey has been continued in the selected pilot project area (Zagazig City-East, Area-4) since 14th of August. The obvious leakage points were not found for the moment.
 - Leakage detection survey was conducted in the candidate pilot project area Zagazig City-East, Area-1 parallel with Area-4. As the result of survey using sound detecting equipment, one leakage was detected at the street No.11 of Area-1 on 19th of August (Refer to Attachment-U1). The leakage was from the crack of the house connection 50mm lead pipe and the volume of leakage was large quantity about 3 l/sec

MM-PTM2-9 (4/4)

- Step3 Workshop was held on August 20th to 21st with the approved programme. Twenty (20) and twenty four (24) attendants were counted.
 - Progress of transfer of New Faqus WTP from NOPWASD
 - ▲ C/P stated that there is no significant progress.

- (5) **Action S5** SOP activities for Water Distribution Control in the Network
- S5-1 Pilot Project for Distribution Control in Small Areas
- Locations of planned flow meters were examined for the actual field conditions such as road, places of indicators and power supply.
- S5-2 Hydraulic analysis of water supply and distribution network
- Preparation of analysis for Zagazig City East Area-4 was continued.
 - Engineer Mahdy Ahmed was nominated as member of hydraulic analysis and first meeting was held on 19th of August.
- (6) **Action S9** Development of Water Quality Control System
- Data entry of historical analysis results is being conducted.
- (7) **Action S10** Well Monitoring
- Well information regarding GPS data were collected.

3-2. Schedule for this week

Above activity will be continued this week.

4. Next PTM

The team proposed to hold 10th PTM on 28th and attendance of the Chairman is to be arranged.

(End of MM)

Attachment

U1: Location map of leakages detected through UFW reduction activity of this week

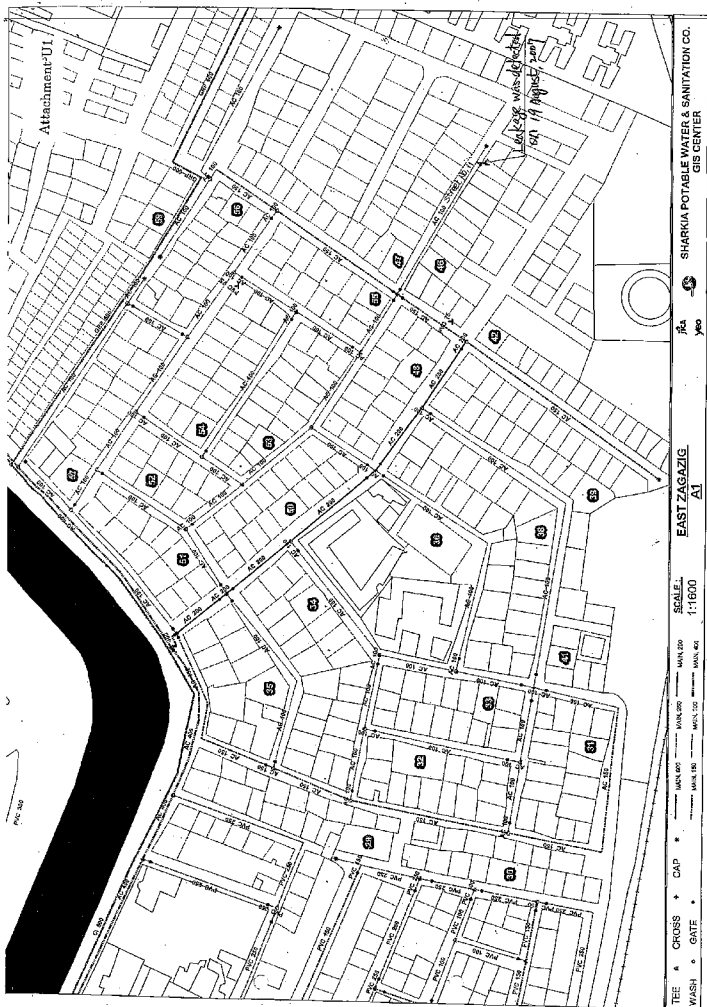

The Project for Improvement of Management Capacity of Operation and Maintenance for SHAPWASCO (Phase-2)

Minutes of Meeting for 10th Project Team Meeting for PH-2
MM-PTM2-10 [07.8.28]

| | | |
|------------|--|---|
| Date | 28 th August (Tuesday) 2007 | Signature |
| Time | 9:30~10:45 | |
| Place | SHAPWASCO chairman's room |  |
| Attendants | <p>[SHAPWASCO : C/P] Eng. Alae El Din Mohamed : Head of UFW/HQ Team Eng. Abdel Shafi Abdel Aziz : Head of SOP/HQ Team Mr. Mohamed Osama Ahmed : Chemist, Head Office</p> <p>[Expert Team : The team] Mr. Masatoshi Seno : UFW Reduction Mr. Akihiko Okazaki : Leakage Detection Mr. Noboru Saeki : SOP Activity Mr. Keizo Kinura : SOP Activity Mr. Mitsuhiro Ozmori : Network Hydraulic Analysis Mr. Mahmoud Khalaf : Senior Engineer (M) for SOP Dr. Ashraf A. Ahmed : Senior Engineer (E) for SOP</p> | |

1. General

The team reported that the following Japanese expert will leave Egypt on the schedule mentioned below:

- ① Mr. Masatoshi Seno : To leave for Tokyo on 29th August 2007

2. UFW reduction activity (progress of last week and issues to be addressed)

2-1. Progress

Actions U2, U3, U4, U9, U10, U11 and U12 have been conducted in the last week and summarized with the progress and the issues to be addressed as follows,

- (1) **Action U2** Conducting leakage (or MNF) survey for candidate sites
 - Remaining MNF survey are Area-1 & 2 of Zagazig City West where the permission for cutting new asphalt road is necessary.
 - The request letter to issue the permission has been prepared but not sent from SHAPWASCO to the governorate yet.
 - ▲ C/P confirmed that this letter will be submitted to the Governorate immediately.

(2) Action U3 Determining pilot project site for each pilot project area

- The data for the registered water meter in the five candidate areas in Zagazig City-East are listed in Table-1. It is recommended to select Area-1 as a pilot area as i) the working pressure inside Area-1 is relatively high and leakages are likely to happen and ii) the number of non working water meters to be replaced is relatively small.

Table-1 Survey on water meters in Zagazig City-East

| Area No. | Total number of water meters | total number of working water meters | total number of non working water meters |
|----------|------------------------------|--------------------------------------|--|
| Area-1 | 1,513 | 1,247 | 266 |
| Area-2 | 1,311 | 848 | 463 |
| Area-3 | 1,357 | 979 | 378 |
| Area-4 | 1,283 | 838 | 445 |
| Area-5 | 1,987 | 1,063 | 924 |

Source: SHAPWASCO Information Center

- The status of the meters in Area-1 shall be checked by SHAPWASCO to secure the required number of new water meters to be installed in replacement of non working meters.
- ▲ It was agreed that the pilot area shall be Area-1 and the number of non working meters to be replaced shall be investigated and confirmed by UFW team of the project by the end of next week.

(3) Action U4 Preparing GIS drawings

- The inputting works for GIS for Zagazig City-West were continued in the last week.

(4) Action U9 Leakage (MNF) survey

- The results of the MNF survey for Area-1 of Zagazig City-East indicated that the MNF was 57.6%. Due to high pressure in the area, it is considered that this MNF ratio is high as the number of persons waiting for night to store water for next day usage is relatively less than Area 4, for example.
- ▲ C/P stated that 57.6% of initial MNF rate in this area shall be clarified in details. Expert team proposed and it was agreed in PTM that i) leakages were detected and repair works were conducted consecutively and this leakage detection survey repair will be continued until next week and ii) after that UFW team shall conduct another MNF survey and see the changes.

(6) Action U10 Water Balance Analysis Before Repair

- According to the UFW action plan, identification of current UFW ratio was tried by "water balance analysis" in Area-4 of Zagazig City-East. However the analysis has been failed due to

unknown water usage resulted from too many non working water meters even though the water consumption was assumed in many cases for non working meters.

- Status of water meters is as shown in the table below.

Table-2 Status of meters in Area-4 of Zagazig City-East

| Item | Number | Percent |
|--|--------|---------|
| Total number of water meter inside network | 1283 | 100% |
| Non working meters | 445 | 34.7% |
| Inaccessible meters | 230 | 17.9% |
| Working Meters | 608 | 47.4% |

- Water balance analysis will be conducted immediately after the replacement of non working water meter in Area-1 of Zagazig City-East and UFW ratio of the area will be identified

- ▲ C/P understood the situation and agreed the change of timing of water balance analysis.

(5) Action U11 Conducting leakage detection survey

- Leakage detection in Area-1 of Zagazig City-East was continued over the last week and two new leakages were detected as mentioned below:

- ① The first leakage was on 2 inch lead pipe feeding Al Naseria School. The leakage which is similar to the leakage found in street No.11 was due to crack of the lead pipe at the bending area of the pipe. The length of crack was about 6cm. The crack was fixed by SHAPWASCO.
- ② The second leakage was detected on Block number 48 on street No. 11. The leakage was due to crack of the 2 inch lead pipe at the bending area of the pipe. The length of crack was about 5cm. The crack was fixed by SHAPWASCO on the same day.
- Another 2 points were detected as the suspect leaking and shall be confirmed in this week.
- The total 5 points including the unconfirmed points have been detected and the locations are shown in the Attachment-U1.

(6) Action U12 Repairing leaking parts

- 3 leakage points detected in Area-1 of Zagazig City-East were repaired by SHAPWASCO immediately.

2-2. Schedule for this week

Above activity will be continued this week.

3. SOP activity (progress of last week and issues to be addressed)

3-1. Progress

Actions S1, S2, S3, S4, S5, S9 and S10 have been conducted currently and summarized with the issues to be addressed as follows,

- (1) **Action S1** Basic System Drawings
 - P&ID and electric single-line diagrams of the model facilities were prepared (draft base) and are to be utilized in Action S4 Development of SOPs for Model Facilities.
 - It is necessary to digitize these drawings for cut-off for the SOP activity of the specific equipment and for the reference to SOP activities in the remaining facilities.
 - SHAPWASCO is preparing to employ a few new employees for CAD operators but they need to be trained.
 - ▲ C/P stated that from September 1st two or three new employees will be assigned to CAD operators but skill is limited and it is appreciated if short period training can be executed in the project.
- (2) **Action S2** Preparation of Unified Forms of O & M Records and Reports
 - Issues for implementation of unified forms of O & M Records were discussed in the Workshop on 20th of August and required hardware upgrading will be submitted from the facilities in writing.
 - Budget allocation shall be considered in Urgent Water Supply Improvement Project.
 - ▲ C/P stated that ordinary budget for the rehabilitation can be applied for this kind of equipment rehabilitations through HCWW and technical corporation by the Expert team is kindly requested.
- (3) **Action S3** Measurement/records of Raw and Treated Water Volume at Seven WTPs
 - Contractors of chamber construction/installation contracts for the first five flow meters in Abbasa WTP were determined by SHAPWASCO and field construction work will be started soon.
 - Schedule of implementation of the installation work and measurements by SHAPWASCO shall be clarified.
 - ▲ C/P confirmed that civil contract was completed and work schedule will be clarified in this week.
- (4) **Action S4** Development of SOPs for Model Facilities
 - Step3 Workshop was held on August 20th to 21st.
 - Preparations of "Headlines of SOP" were started for other model facilities than Abbasa and will be finalized in next week.
 - SOP activities in both mechanical and electrical field started in Abbasa and Zaagazig respectively.

- (5) **Action S5** SOP activities for Water Distribution Control in the Network
 - SS-1 Pilot Project for Distribution Control in Small Areas
 - Outline and Plan of flow meter installations was prepared with the Network Engineer of Hihya Branch (Attachment S1).
 - It contains five points of flow rate measurements and four new chambers are required. After the approval of PTM, drawings for construction and specifications shall be prepared by the Project and SHAPWASCO shall prepare the construction/installation works.
 - SS-2 Hydraulic analysis of water supply and distribution network
 - Preparation of analysis for Zagazig City East Area-4 was continued.
 - Engineer Mahdy Ahmed of Hihya Branch was nominated as member of hydraulic analysis and training was started from 20th of August.
 - ▲ C/P agreed the plan and requested increase of the pilot project members from SHAPWASCO.
 - ▲ Expert team welcomed the new members.
- (6) **Action S9** Development of Water Quality Control System
 - Data entry of historical analysis results is being conducted.
- (7) **Action S10** Well Monitoring
 - Well information regarding GPS data were collected.

3-2. Schedule for this week

Above activity will be continued this week.

4. Attachment

Attachment U1: Results of Leakage Detection in Zagazig City East Area-1 as of August 27
Attachment S1: Plan of "Pilot Project for Distribution Control in Small Areas"

5. Next PTM

The team proposed to hold 11th PTM on Sunday, 9th of September.

(End of MM)

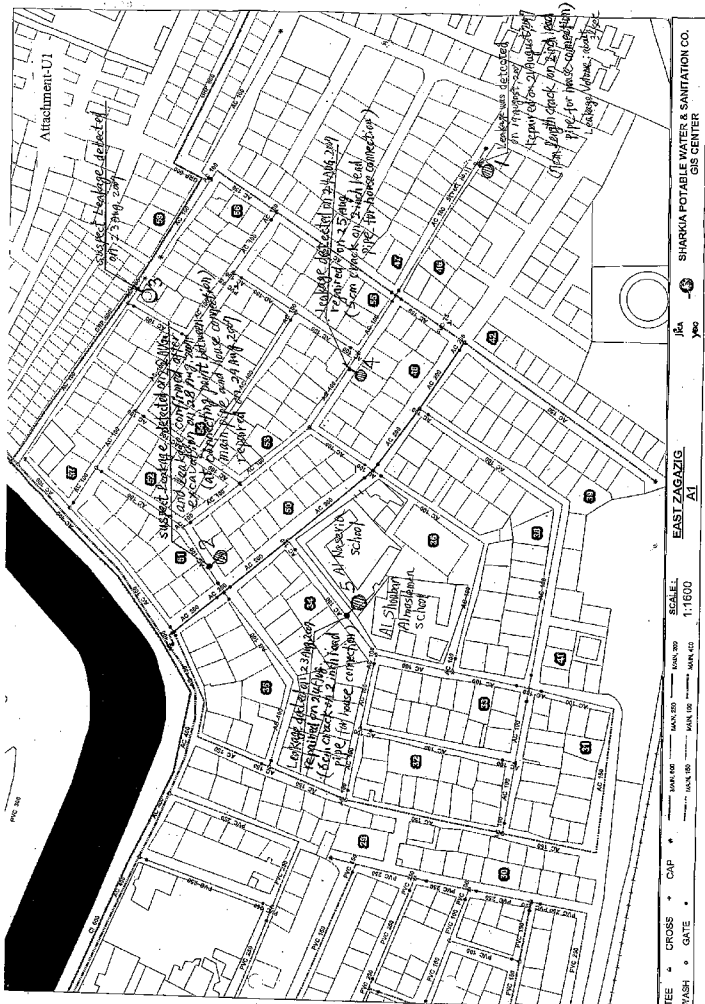

Attachment S1

August 28, 2007

Outline of Proposed Plan of "Pilot Project for Distribution Control in Small Areas" by Action S5-1

Objectives

- ☆ To improve the management capacity of Sector and HQ for distribution control in small areas through actual measurements and analysis of water distribution inside Markaz

Proposed Pilot Area

- ☆ Hihya Markaz was selected as the pilot area for this action due to the following criteria:
 - Decent size for the pilot area
 - Newly constructed WTP with a production recoding and management system
 - Water distribution trunk line based on the Master Plan
- ☆ Hihya Markaz is analyzed in the five small areas as shown attached "General Layout" and five bulk flow meters are located to grasp distribution volumes of four small areas and north area of Hihya City (Q city-N = Q total - Q1 - Q2 - Q3). Total distribution volume to Hihya City can not be calculated by the measurement of these five bulk flow meters due to some other feedings to Hihya City and some estimation are required. Additional flow meter allocations and measurements may be considered when meticulous management will become necessary afterwards.

Activities

- ☆ Workshop in Hihya Branch:
 - Purpose and activities of the pilot project will be explained to the related persons of the Hihya Branch and activity programme will be finalized through discussions/suggestions there.
- ☆ Data collection of the pilot areas:
 - Data regarding population, number of customers, billed water volumes, future development plans and other social conditions will be collected for the basis of the analysis.
- ☆ Preparation of ultra-sonic flow meters:
 - Five ultra-sonic flow meters for this action will be purchased by the Project and will be delivered to Sharquiya.
- ☆ Construction of flow meter chambers:
 - New flow meter chamber will be constructed and flow meters and indicators will be installed by SHAPWASCO.
- ☆ Flow rate and pressure measurements:
 - Flow rates and pressures of the points will be measured and recorded together with the operation/production records of new Hihya WTP and well stations. Method of pressure measurements will be discussed and determined in the workshop above.
- ☆ Analysis and report:
 - Analysis including proposal/recommendation for improvement of distribution system will be made and reported as the output of the pilot project.

Attachment S1

- Current distribution state in each area
- Remedial method of unbalance distribution system, if any
- Necessary upgrading for future development

Collaboration with Action S5-2 Hydraulic Analysis

☆ As one of the model network systems, Hiyia Markaz will be studied by the hydraulic analysis in S5-2 action and collected data and measurements results will be used and results of hydraulic analysis will be reflected in the S5-1 analysis.

Schedule

- ☆ Workshop in Hiyia Branch: September 2007
- ☆ Data collection of the pilot areas: September 2007
- ☆ Arrival of flow meters purchased in Japan: November 2007
- ☆ Construction of flow meter chambers: October 2007
- ☆ Flow rate and pressure measurements: December 2007
- ☆ Analysis and report: February 2008

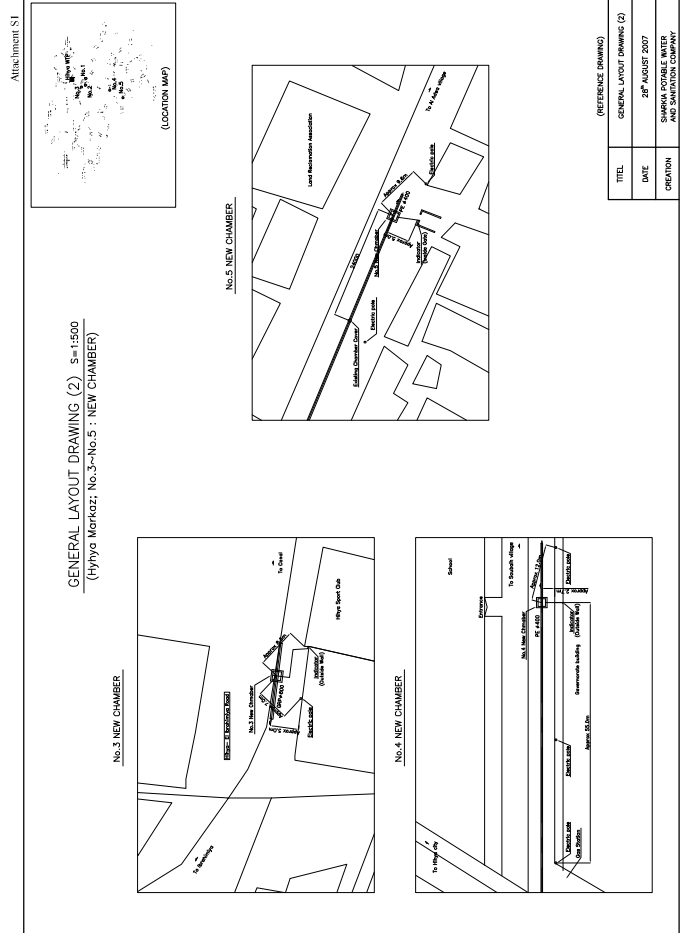
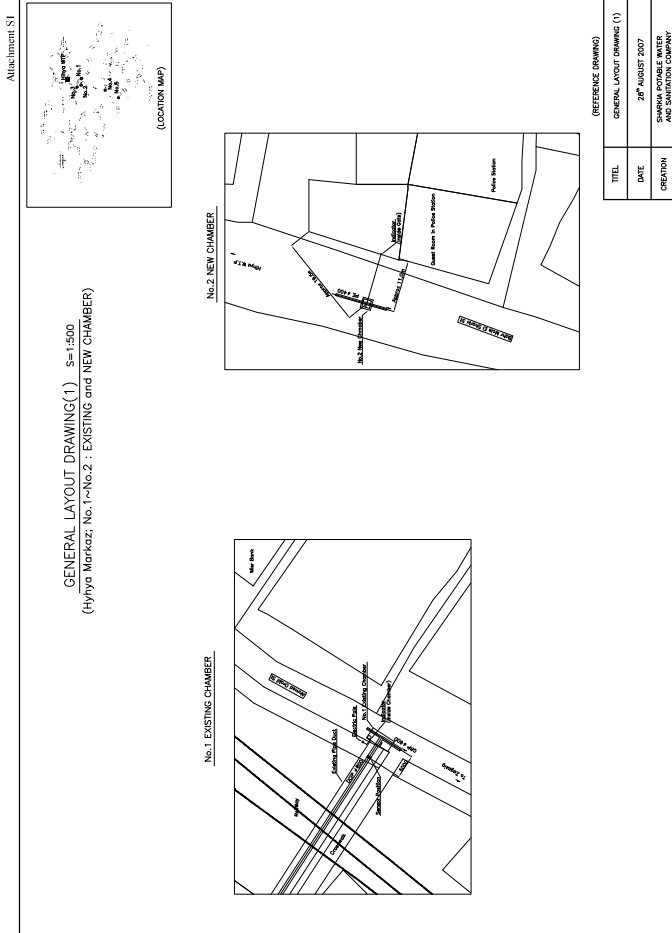

Attachment S1

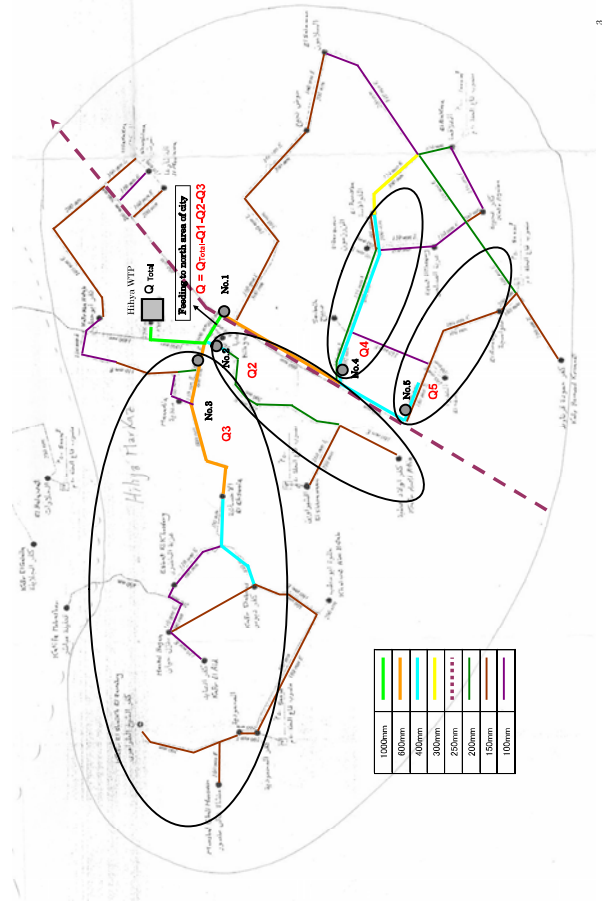

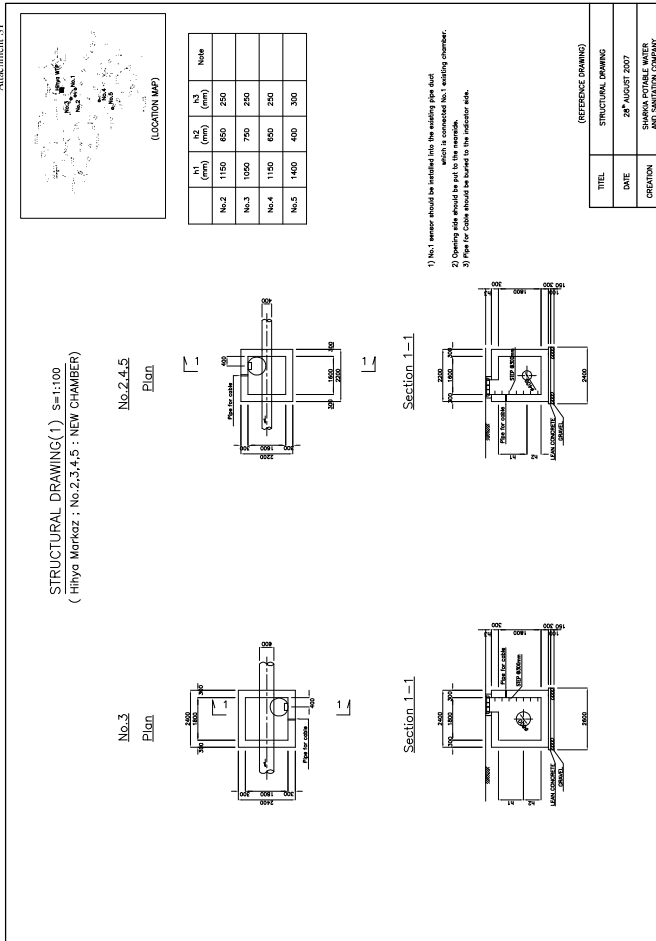

MM-PTM2-11 (2/5)

- SHAPWASCO did not get the permission, yet.
 - A MNF survey has been conducted for Zagazig City West Area-4 (Hassan Saleh). The previous run was not successful due to lack of data for 6 hours around midnight. The reason may be due to misalignment as the sensor is installed inside the tunnel under railway.
 - The MNF was 12.35 l/s with an average ratio of MNF of 72.7% which is considered a high value compared to other measured areas. The average pressure was 2.2 bars at the inlet point and 1.0 bar at the end point in the network. The minimum night flow occurs at 6:23 a.m.
- (2) **Action U3** Determining pilot project site for each pilot project area
- The status of the meters in Area-1 is conducted by SHAPWASCO and the required number of meters to be replaced shall be determined as per schedule.
- (3) **Action U4** Preparing GIS drawings
- The inputting works for GIS for Zagazig City-West were interrupted and the inputting works for Hihya Markaz was started in the last week.
- (4) **Action U8** Meter Error and Wastage in House
- To determine the average wastage in a house, a flow meter was installed on the inlet pipe to a number of houses in area 1. The meter was allowed to register the consumed water over a period of 24 hours.
 - The measurements indicated that a minimum use of about 10 l/h/meter.
 - Considering this average the total MNF could be reduced by an amount of 3.3 l/s and hence reducing the leakage ratio.
 - ▲ It was confirmed that another five (5) sample houses, total ten (10) will be surveyed according to the action plan.
- (5) **Action U9** Leakage (MNF) survey
- A MNF survey has been conducted for Zagazig City East Area-1 after repair. A good improvement has been recorded. The MNF value reduced from 11.56 l/s to 7.82 l/s meaning that the MNF percent has been reduced from 57.64% to 43.98%. This saving in MNF give reduction in total flow from 1706 m³/d to 1500 m³/d with saving of 206 m³ means annual saving of 52,600 L.E. based on actual water cost of 0.70 L.E./m³.

2

MM-PTM2-11 (1/5)

The Project for Improvement of Management Capacity of
Operation and Maintenance for SHAPWASCO (Phase-2)

Minutes of Meeting for 11th Project Team Meeting for PH-2
MM-PTM2-11 [07.9.09]

| | | |
|------------|---|------------------|
| Date | 9 th September (Sunday) 2007 | Signature |
| Time | 9:30 ~ 10:30 | |
| Place | SHAPWASCO chairman's room | |
| Attendants | [SHAPWASCO : C/P] Eng. Alaa El Din Mohamed : Head of UFW/HQ Team Eng. Abdel Shafi Abdel Aziz : Head of SOP/EQ Team | <i>Eng. A.</i> |
| | [Expert Team : The team] Mr. Akihiko Okazaki : Leakage Detection Mr. Noboru Saeki : SOP Activity Mr. Keizo Kimura : SOP Activity Mr. Mitsuhiro Omori : Network Hydraulic Analysis Mr. Mohamed Nagi : Facilitator Dr. Mohamed Sobhy : Senior Engineer (C) for UFW Dr. Ashraf A. Ahmed : Senior Engineer (E) for SOP | <i>Dr. M. S.</i> |

1. General

The team reported that the following Japanese and Egyptian expert will leave Sharquiya on the schedule below:

- ① Dr. Mohamed Sobhy: to leave Sharquiya on 12th September, 2007
 - ② Mr. Noboru Saeki: to leave Sharquiya for Tokyo on 13th September 2007
 - ③ Mr. Akihiko Okazaki: to leave Sharquiya for Tokyo on 16th September 2007
- ▲ C/P requested to prepare a list of UFW reduction activities required during the absence of Mr. Okazaki and Dr. Sobhy. Expert team agreed and informed that Mr. Seno is scheduled to arrive on 2nd of October.

2. UFW reduction activity (progress of last week and issues to be addressed)

2-1. Progress

Actions U2, U3, U4, U8, U9, U11 and U12 have been conducted in the last week and summarized with the progress and the issues to be addressed as follows,

- (1) **Action U2** Conducting leakage (or MNF) survey for candidate sites
- Remaining MNF survey are Area-1 & 2 of Zagazig City West where the permission for cutting new asphalt road is necessary.

1

MM-PTM2-11 (3/5)

- (6) **Action U11** Conducting leakage detection survey
- Leakage detection in Area-1 of Zagazig City-East was completed on the last week. The total number of leakage points were 7 as indicated in attachment-U1.
 - Leakage points No. 3 and 6 are outside the study area. These two points shall be used in the training workshop that shall be held for UFW teams.
 - Leakage point No. 7 was reported by the home owner before leakage detection survey team reached the area.

(7) **Action U12** Repairing leaking parts

- All five leakage points has been repaired by SHAPWASCO in due time. The remaining two points shall be fixed after the training workshop.

2-2. Schedule for this week

Above activity will be continued this week.

- ▲ It was agreed that the training workshop for UFW reduction activities will be held for two days, i.e. 11th and 12th of September, considering the training efficiency for the number of attendants of sixty (60).
- ▲ Contents of the workshop will be 1) Class room explanation using video/pictures by Zagazig East team and; 2) Field experiences at leakage points in Area-1 of Zagazig City-East.

3. SOP activity (progress of last week and issues to be addressed)

3-1. Progress

Actions S1, S2, S3, S4, S5, S9 and S10 have been conducted currently and summarized with the issues to be addressed as follows,

(1) **Action S1** Basic System Drawings

- Eng. Hesham Gamal was nominated as CAD-operator/system information engineer on 1st of September and started digitization of P&ID and electric single-line diagrams of the model facilities.
- Computers at model facilities shall be prepared for utilization of digitized drawings as agreed in the previous PTM.
- ▲ C/P confirmed that computers are under final check and will be delivered until 20th of September.
- ▲ Expert team proposed to transfer prepared digitized drawings and data to them when ready.

(2) **Action S2** Preparation of Unified Forms of O & M Records and Reports

- Required hardware upgrading for implementation of unified forms of O & M Records were reported from Hihya WTP and New Faqus WTP.

3

- Requirements of remaining facilities shall be confirmed.
- (3) **Action S3** Measurement/records of Raw and Treated Water Volume at Seven WTPs
 - Construction of flow meter chambers for the first five flow meters in Abbasa WTP was started. First chamber will be ready to use by the end of September.
 - Schedule of the mechanical/electrical installation work for flow meters shall be clarified.
- (4) **Action S4** Development of SOPs for Model Facilities
 - Preparations of "Headlines of SOP" were finished for model facilities except Bilbais BPS.
 - SOP activities in both mechanical and electrical field were started in Abbasa and Zaagazig respectively.
 - Rehabilitation plan of low voltage panel boards at Bilbais BPS was prepared (Attachment S1)
 - SOP headlines for Bilbais BPS shall be followed.
 - ▲ It was reported that SOP headlines for Bilbais BPS was submitted on 9th of September to SOP/HQ team.
- (5) **Action S5** SOP activities for Water Distribution Control in the Network
 - S5-1 Pilot Project for Distribution Control in Small Areas
 - Outline and Plan of flow meter installations was prepared with the Network Engineer of Hihya Branch and reported in the workshop on 1st of September at Hihya WTP.
 - Drawings for construction and specifications shall be prepared by the Project.
 - SHAPWASCO shall prepare the construction/installation works for five flow meters and four new chambers.
 - ▲ Expert team confirmed the date of finalization of drawings and specifications for the above flow meter installation works will be 16th of September.
 - ▲ C/P agreed to proceed with internal contracting procedures for the works accordingly.
 - S5-2 Hydraulic analysis of water supply and distribution network
 - Preparation of analysis for Zagazig City East Area-4 was continued.
- (6) **Action S9** Development of Water Quality Control System
 - Data entry of historical analysis results is being conducted.
- (7) **Action S10** Well Monitoring
 - Well monitoring was started in Ibrahimiya Markaz.

3-2. Schedule for this week

Above activity will be continued this week. And following special event is considered.

- Visit to Abu Hommos WTP of Beheira Water Company will be arranged as a SOP activity.
- ▲ Date of the visit will be decided later and may not be possible in this week.

4. Attachment

Attachment U1: Location of leak point in Zagazig East Area-1
Attachment S1: Report of Low Voltage panel boards at Belbees BPS

5. Next PTM

The team proposed to hold 12th PTM on Sunday, 16th of September.

(End of MM)

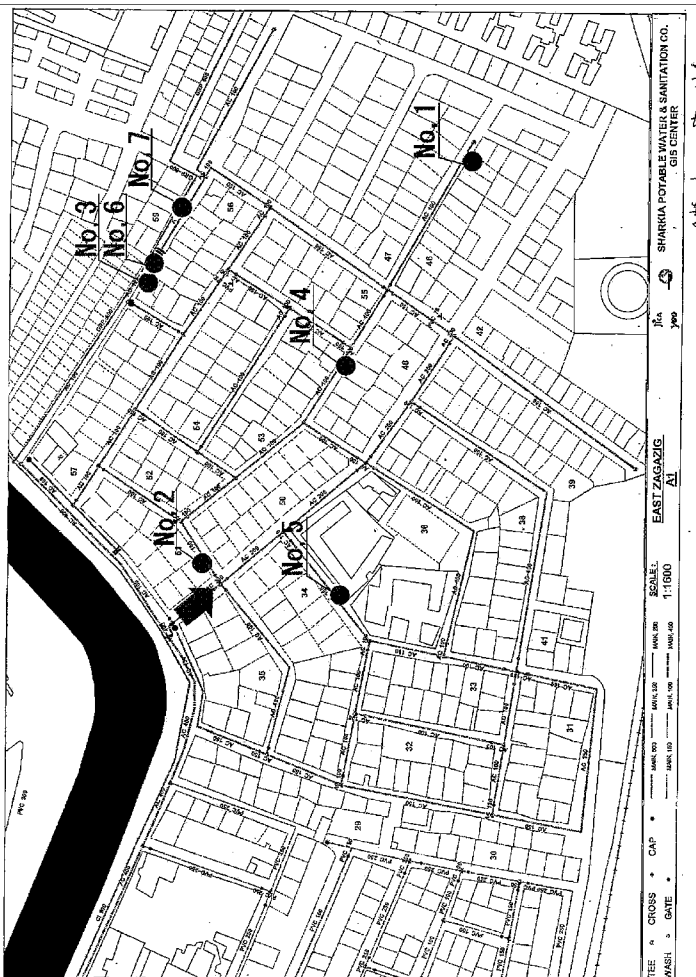

Attachment S-1

Report

Rehabilitation of low voltage panel boards at Belbees booster station

Regarding the main low voltage panel board at Belbees booster station, it is new panel and there is no visual comment on it.

Regarding the ATS (Automatic Transfer Switch) between low voltage mains & Generator electric power output, as seen from the attached photos, the panel is subjected to corrosive environment. Although the ATS panel is a new panel, the metallic conductors and control wires inside the panel were corroded because during installation process the panel was not commissioned and IP65 of the panel were lost.

To rehabilitate the ATS panel, the IP65 of the panel should be kept at the bottom of the panel by proper metallic sheet (from EMGI, the panel manufacturer) which is fixed probably with isolating tape. The power and control cables should penetrate the metallic sheet through proper cable glands.

Also, a complete inspection of the circuit breaker, auxiliary contacts and all other components of the ATS panel should be done.

I recommend the panel manufacturer to do such rehabilitation.

Kind Regards
Dr. Ashraf Ahmed



MM-PTM2-12 (1/4)

The Project for Improvement of Management Capacity of
Operation and Maintenance for SHAPWASCO (Phase-2)

Minutes of Meeting for 12th Project Team Meeting for PH-2
MM-PTM2-12 [07.9.16]

| | | |
|------------|---|---|
| Date | 16 th September (Sunday) 2007 | Signature |
| Time | 9:30~10:30 | |
| Place | SHAPWASCO chairman's room | |
| Attendants | <p>[SHAPWASCO : C/P]</p> <p>Eng. Alse El Din Mohamed : Head of UFW/HQ Team Eng. Abdel Shafi Abdel Aziz : Head of SOP/HQ Team Mr. Mohamed Osama Ahmed : Chemist, Head Office</p> <p>[Expert Team : The team]</p> <p>Mr. Akihiko Okazaki : Leakage Detection Mr. Keizo Kimura : SOP Activity Mr. Mitsuhiro Omori : Network Hydraulic Analysis Dr. Ashraf A. Ahmed : Electric Equipment Mr. Mohamed Nagi : Facilitator</p> | <p><i>Eng. Alse</i></p> <p><i>大森 光仁</i></p> |

1. General

The team reported that the following Japanese expert will leave and arrive at Egypt on the schedule mentioned below:

- ① Mr. Akihiko Okazaki: To leave for Tokyo on 16th September 2007
- ② Mr. Takashi Hara: To arrive at Egypt on 18th September 2007

2. UFW reduction activity (progress of last week and issues to be addressed)

2-1. Progress

Actions U2, U4, U11 and U12 have been conducted in the last week and summarized with the progress and the issues to be addressed as follows,

- (1) **Action U2** Conducting leakage (or MNF) survey for candidate sites
 - Remaining MNF survey are Area-1 & 2 of Zagazig City West where the permission for cutting new asphalt road is necessary.
 - SHAPWASCO did not get the permission, yet.
- (2) **Action U4** Preparing GIS drawings
 - The updating works for Hihya city and inputting works for Hihya Markaz has conducted.



MM-PTM2-12 (2/4)

- (3) **Action U11** Conducting leakage detection survey
 - Work shop was held on 11th and 12th on September. Zagazig team explained the leakage detection in Area-1 of Zagazig City-East. Attendance had field training by support of Zagazig team and Japanese expert.
- (4) **Action U12** Repairing leaking parts
 - Investigation of telephone line for remaining two leaking points of Zagazig city Area-1 was conducted after work shop. These leaking points shall be fixed by SHPWASCO.
 - ▲ SHAPWASCO will proceed repair work after coordination with the Telephone Company.
- (5) List and Schedule of UFW activities
 - Tentative schedule of September and October was prepared.(Attachment U-1)

2-2. Schedule for this week

Activity will be continued this week by above schedule.

3. SOP activity (progress of last week and issues to be addressed)

3-1. Progress

Actions S1, S2, S3, S4, S5, S9 and S10 have been conducted currently and summarized with the issues to be addressed as follows,

- (1) **Action S1** Basic System Drawings
 - Eng. Hesham Gamal has conducted digitization of P&ID, electric single-line diagrams, layout and piping & cable route drawing of the model facilities.
 - Drawing title is prepared and proposed. (Attachment S-1)
 - Expert team will distribute the digitized drawing one by one, when computers become ready.
 - Computer for model facilities will prepare until 20th September according to previous PTM
 - ▲ SHAPWASCO is trying to prepare five computers until 20th September.
- (2) **Action S2** Preparation of Unified Forms of O & M Records and Reports
 - Required hardware upgrading for implementation of unified forms of O & M Records were reported from Hihya WTP and New Faqus WTP.
 - Requirements of remaining facilities shall be confirmed.
 - ▲ Requirements of Bilbais BPS and Zagazig WTP were also reported.
- (3) **Action S3** Measurement/records of Raw and Treated Water Volume at Seven WTPs
 - Construction of flow meter chambers for the first five flow meters in Abbasa WTP was

| | | |
|--|---------------|--------------------|
| 0 | First issue | 12-09-2007 |
| Rev. | Modifications | Date |
|  <p>THE PROJECT FOR Improvement of Management Capacity of Operation and Maintenance for SHAPWASCO by JICA Technical Cooperation</p> <p>Abbasa Water Treatment Plant</p> <p>P&ID for Chlorination Facility</p> | | |
| Prepared by: | Checked by: | Approved by: |
| | | |
| | | September 12, 2007 |
| | DWG No. | ABS-PID-02 |

September 13, 2007

Instruments required electrical SOP activities

- Phase sequence meter
- Avometer voltage upto 1000 and ampere 2-20 amp
- Clamp metre AC upto 2000 amp
- Dial meter strand & filler
- Meger 500V, 2500V and 5000V
- M-V detection prob (3.3KV, 11KV, and 20KV)
- Earthing resistance meter
- LCR
- Vibration and noise instruments
- Tools, pullout tools, torque spanner, press tool for lugs, press tools for terminals

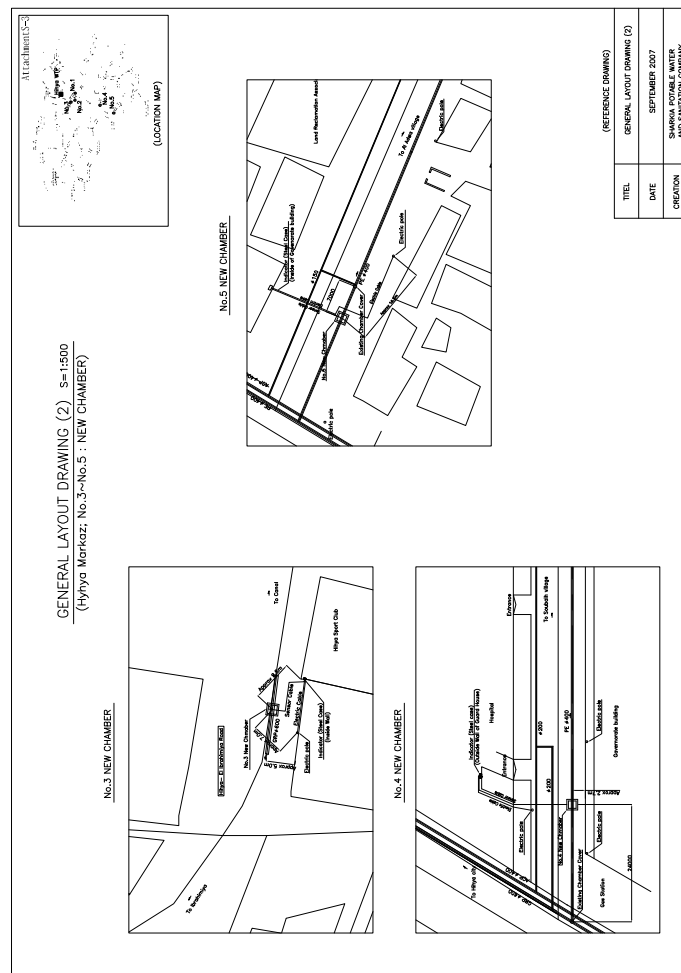
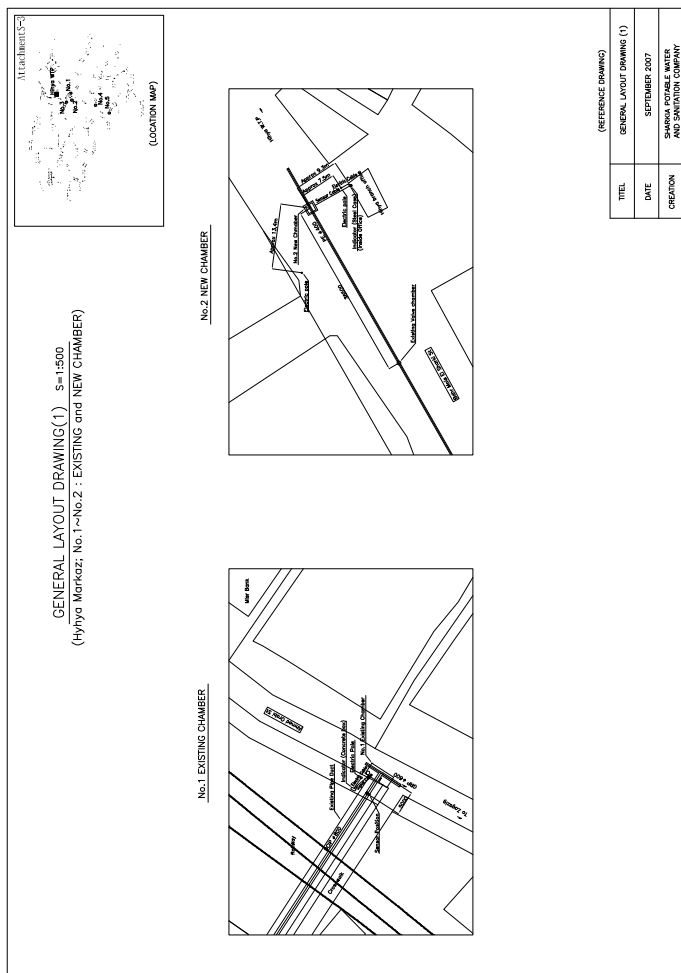

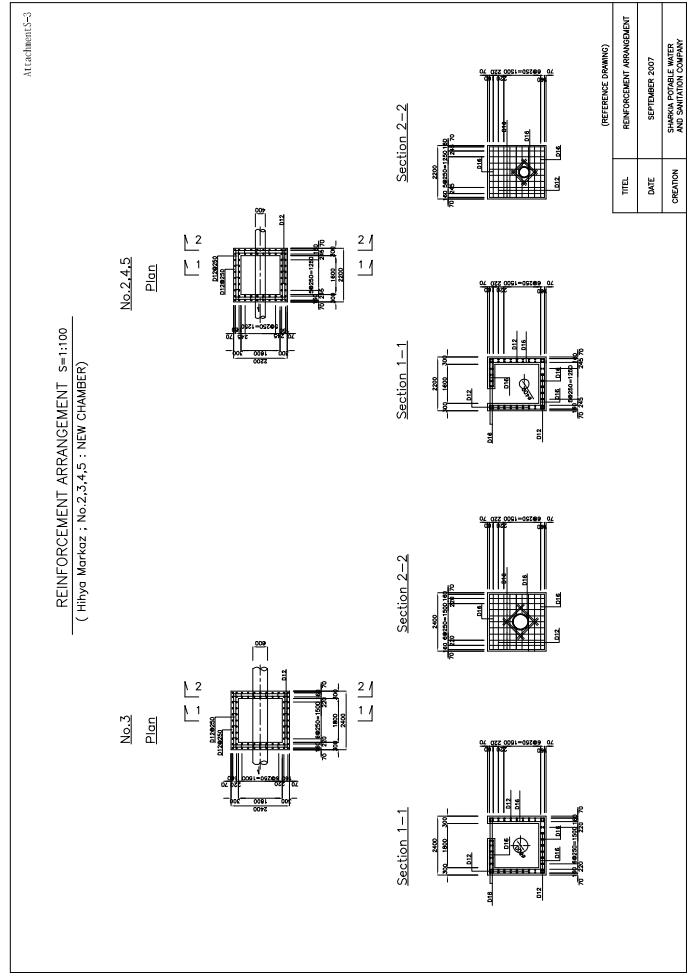
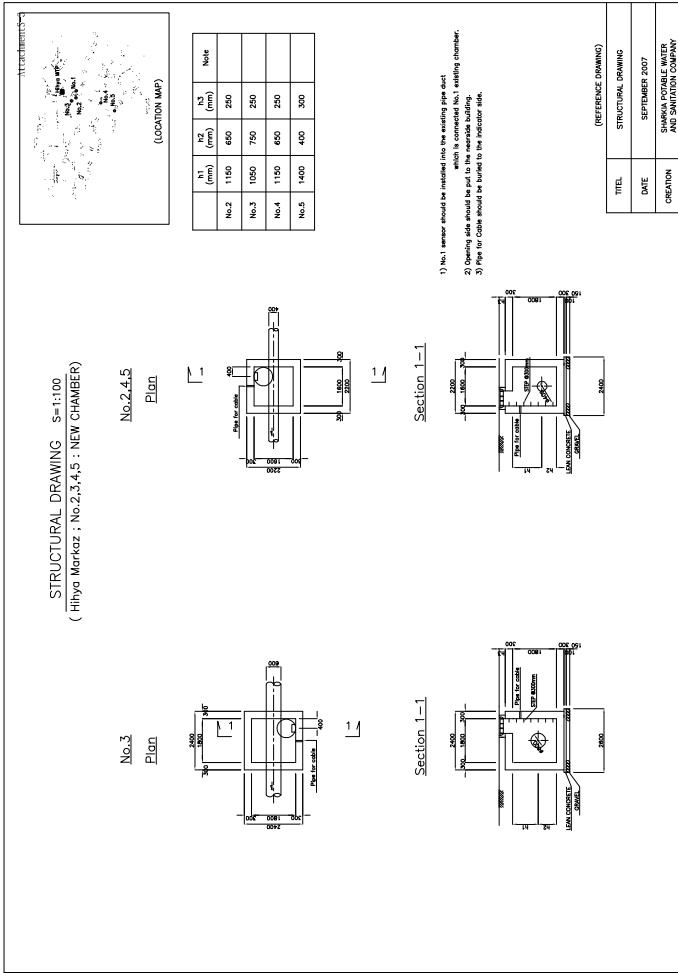
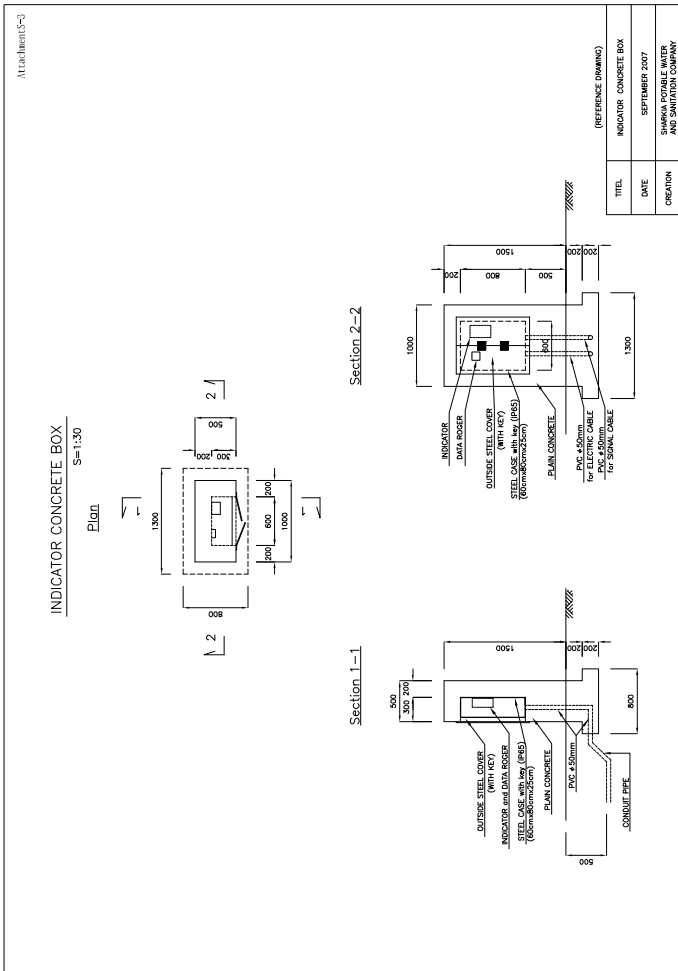

Attachment S-3

SPECIFICATIONS
For
INSTALLATION WORK of FIVE FLOW METERS in HIHYA MARKAZ

This specification covers the works for the construction of manholes and installation of five ultrasonic flow meters in Hihya Markaz.

Scope of the works of the contractor;

1. Construction of four reinforced concrete manholes with manhole cover and steps.
2. Supply and installation of five outdoor panels/boxes for indicators/converters, data loggers and electric power switches.
3. Power supply works between the outdoor panels and power sources designated by SHPWASCO including supply of power switches, power cable and conduit pipes
4. Installation work of five flow meters and five data loggers including preparation of pipe surface (cleaning and polishing), fixation of sensors, installation of signal cables between centers and indicators/converters with conduit pipes and test/calibrations according to the manufacture's installation manual.
5. Pavement for the parts damaged by above works.
6. Five sets of ultra sonic flow meter sensors with fixing devices and indicators/converters with signal cable (cable length is only thirty (30) meters) and data logger with cable are provided by SHAPWASCO.

Specifications

1. General
 - 1) The exact location and depth of the chambers should be decided based on actual situation at site.
 - 2) Contractor has to comply with standard construction specifications of SHPWASCO.
 - 3) Location and structural requirements for manholes and outdoor panels are shown attached drawings.
 - 4) The contractor has to follow the attached installation instructions and specifications of the bulk flow meters.
 - 5) Contractor has to submit as built drawing.
2. Chamber for bulk flow meter
 - 1) The chamber position shall be decided considering that required distances are secured from joints and valves and sensor position is around center of chamber.
 - 2) The minimum distance between the bottom of the pipe and top of concrete base is 200mm as per figure of last page.

- 3) The new chamber should be totally water tight by means of cleaning of laitance at construction joint, sealing at joint of existing pipes, placing wall concrete in one stage and using water tight shattering etc.
 - 4) Signal cable should be sent out in conduit pipe from chamber to indicators/converters in the out door panels.
3. Installing of flow meter
- 1) Installing of the censor should be the "Z" method/single traverse specified in the manual.
 - 2) Outdoor panel should be protected from direct sunlight, rainfall and dust/sandstorm (equivalent to IP65).
 - 3) Basic dimension of outdoor panel is shown by attached drawing. However drawings of outdoor panels shall be submitted to SHAPWASCO for approval before manufacturing, because installation of outdoor panels is outside of water treatment plant and reconfirmation of installation is necessary and the care of stealing is required.
 - 4) Drawings of power supply and control shall be submitted to SHAPWASCO for approval before the work.

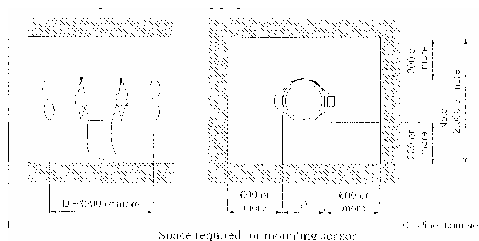

The Project for Improvement of Management Capacity of
Operation and Maintenance for SHAPWASCO (Phase-2)

Minutes of Meeting for 13th Project Team Meeting for PH-2
MM-PTM2-13 [07.10.1]

| | | |
|------------|---|---|
| Date | 1 st October (Monday) 2007 | Signature |
| Time | 9:45~10:30 | |
| Place | SHAPWASCO chairman's room |  |
| Attendants | [SHAPWASCO : C/P] Eng. Alaa El Din Mohamed : Head of UFW/IQ Team Eng. Abdel Shafi Abdel Aziz : Head of SOP/HQ Team Mr. Mohamed Ossama Ahmed : Chemist, Head Office [Expert Team : The team] Mr. Keizo Kimura : SOP Activity Mr. Mitsubishi Omori : Network Hydraulic Analysis Mr. Takashi Hara : Water Quality Control Mr. Mohamed Nagi : Facilitator | |

1. General

(1) Japanese Expert schedule

The team reported that the following Japanese expert will arrive at Egypt on the schedule mentioned below:

- Mr. Masatoshi Sono: To arrive at Egypt on 2nd October 2007

(2) Water conservation education activity

> Water conservation education activity should be conducted in October. Expert team already advised about this activity on 26th June.

- As the first step, SHAPWASCO has to select schools that may participate in the campaign activity.
- Next step, SHAPWASCO has to prepare the necessary materials in corporation with the Expert Team (Pamphlet, Questionnaires, Invitation letter, Sticker etc).

2. UFW reduction activity (progress of last week and issues to be addressed)

2-1. Progress

Actions U2, U4 and U8 have been conducted in the last week and summarized with the progress and the issues to be addressed as follows,

- (1) **Action U2** Conducting leakage (or MNF) survey for candidate sites

1

- > Remaining MNF survey are Area-1 & 2 of Zagazig City West where the permission for cutting new asphalt road is necessary.
- > SHAPWASCO did not get the permission, yet.

(2) Action U4 Preparing GIS drawings

- > The updating works for Hihya city and inputting works for Hihya Markaz has conducted.

(3) Action U8 Measuring meter error of water meter

- The status of the meters had been surveyed and the number of non working meters had been determined according to the schedule which was submitted at previous PTM.

▲ SHAPWASCO did not start yet, and they will start the activity from this week.

2-2. Schedule for this week

Activity will be continued this week.

3. SOP activity (progress of last week and issues to be addressed)

3-1. Progress

Actions S1, S3, S4, S5, S9 and S10 have been conducted currently and summarized with the issues to be addressed as follows,

(1) Action S1 Basic System Drawings

- > Eng. Hesham Gamal has conducted digitization of P&ID, electric single-line diagrams, layout and piping & cable route drawing of the model facilities and digitization of P&ID was finished. (AttachmentU-1)
- > Expert team will distribute digitized drawing of P&ID to be checked by model facilities staff.
- Situation of computer for model facilities which would prepare until 20th September.
- ▲ Hihya branch received the computer and other branch will proceed.

(3) Action S3 Measurement/records of Raw and Treated Water Volume at Seven WTPs

- > Remaining drawings of new sixteen flow meters show the attachment U-2.
- > No.3 flow meter in Abbasa WTP should be changed to one of the next sixteen flow meters which will arrive on December, because the location of Faqus Markaz was decided and this pipe material is asbestos and there is a possibility that next sixteen flow meters cannot measure asbestos pipe.
- > Construction of flow meter chambers for the first five flow meters in Abbasa WTP is continued.
- Schedule of the mechanical/electrical installation work for flow meters shall be clarified.

(4) Action S4 Development of SOPs for Model Facilities

- > Preparation of SOP documents has been conducted.

(5) Action S5 SOP activities for Water Distribution Control in the Network S5-1 Pilot Project for Distribution Control in Small Areas

- SHAPWASCO shall prepare the construction/installation works for five flow meters and four new chambers.
- S5-2 Hydraulic analysis of water supply and distribution network
- > Preparation of analysis in Hihya Markaz has been conducted.
- > Ms. Heba was nominated as member of hydraulic analysis and training was started from today.

(6) Action S9 Development of Water Quality Control System

- > A workshop of auditing system was held on the 27th September. The number of the attendance was 10 persons.
- > Progress for the Water Quality Control Programmes for Abbasa and Zagazig was reported.

(7) Action S10 Well Monitoring

- > Well monitoring was started in Ibrahimiya Markaz.

3-2. Schedule for this week

Above activity will be continued this week.

4. Attachment

Attachment S1: Digitization of P&ID
Attachment S2: Drawing for remaining sixteen flow meters

5. Next PTM

The team proposed to hold 14th PTM on Monday, 8th of October.

(End of MM)

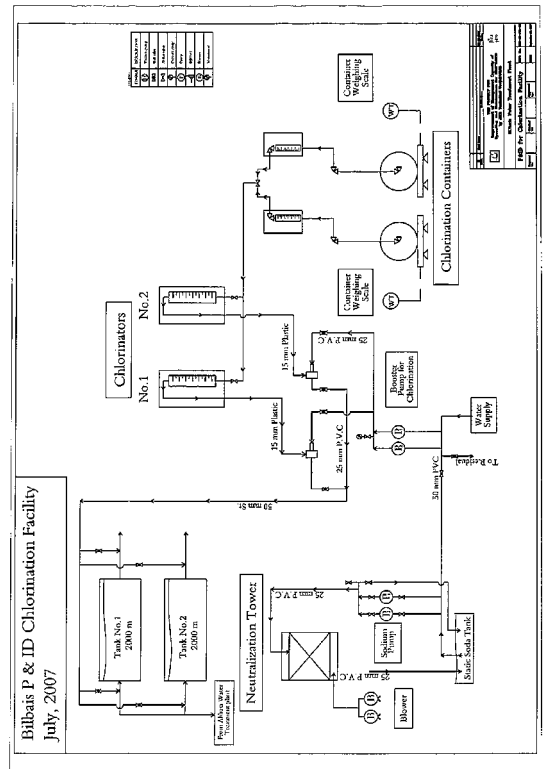
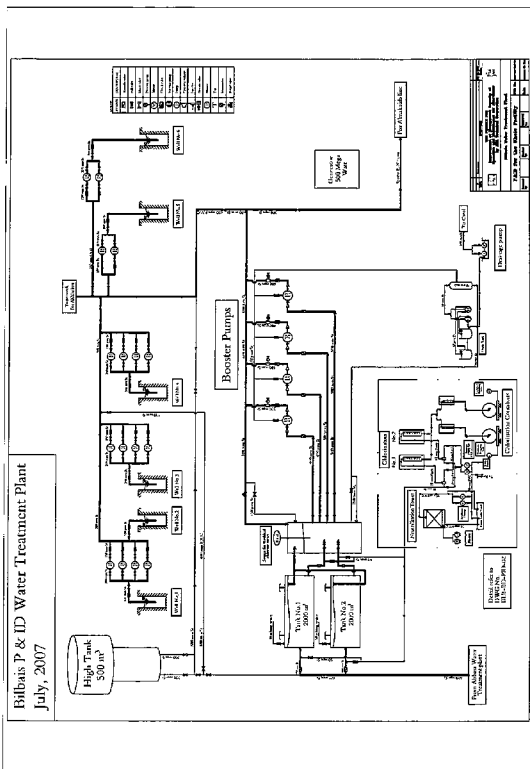
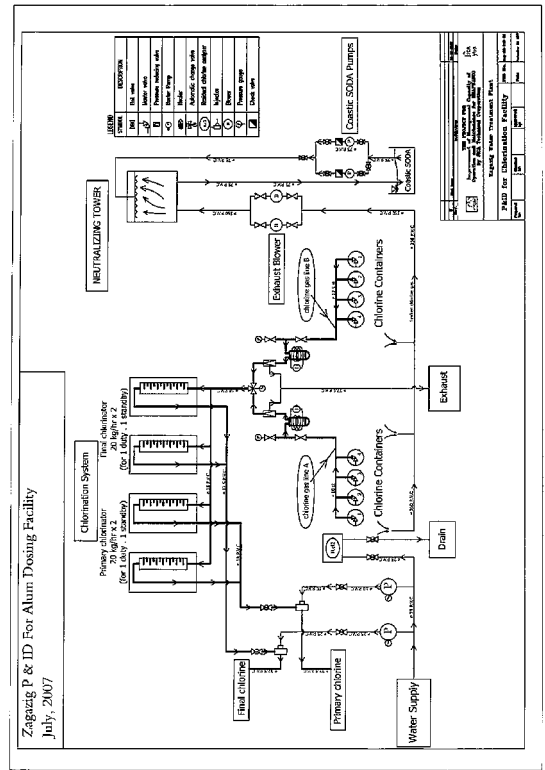
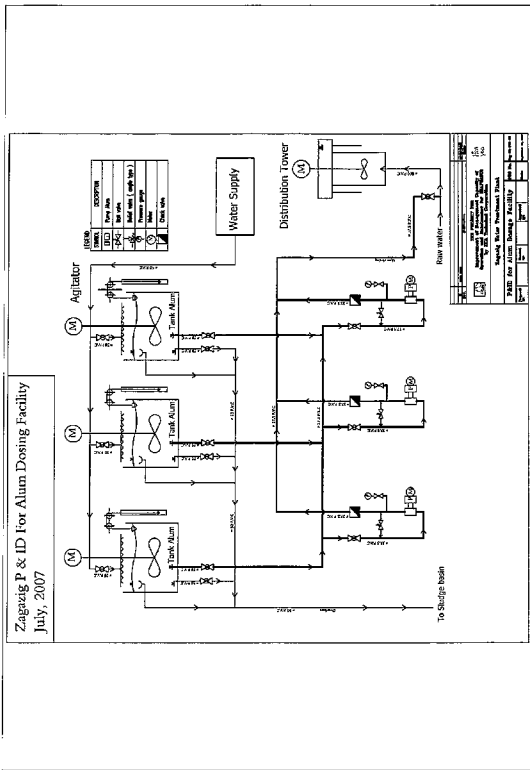

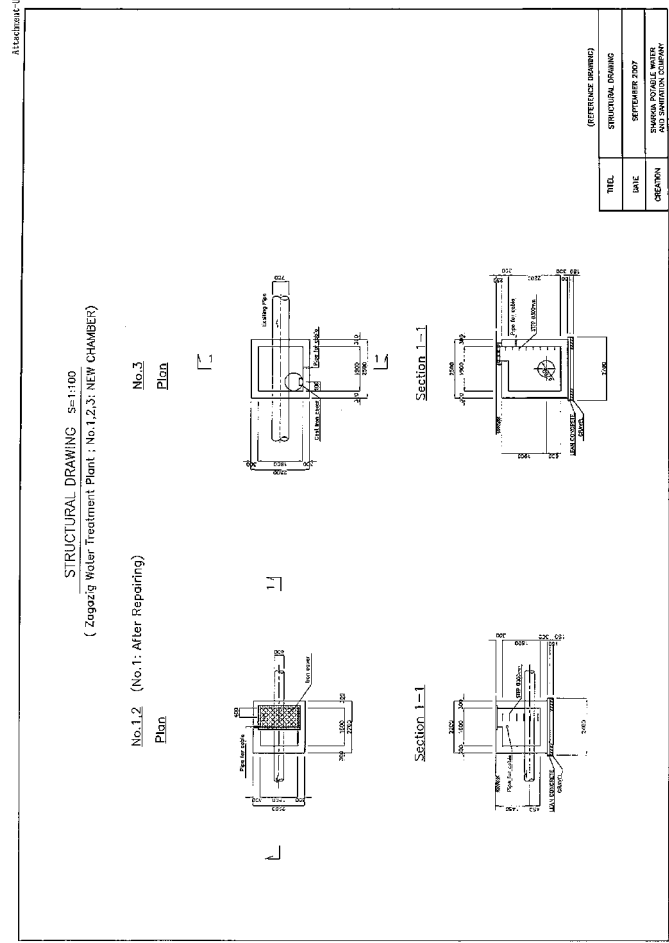
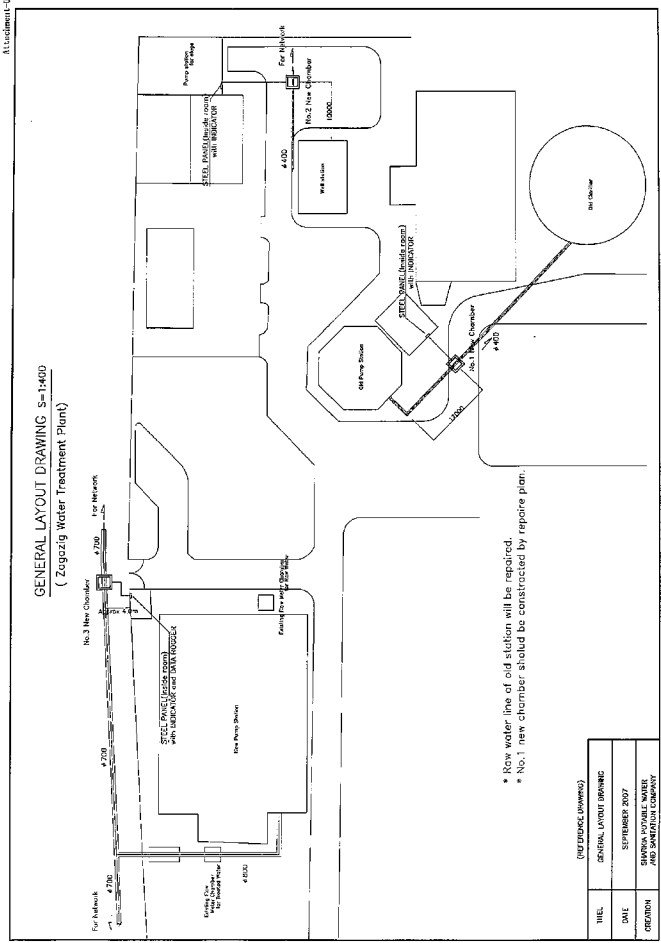
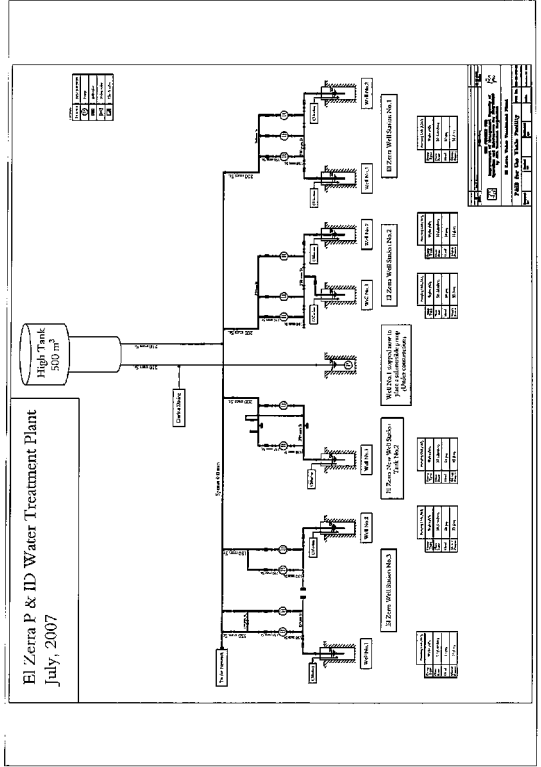
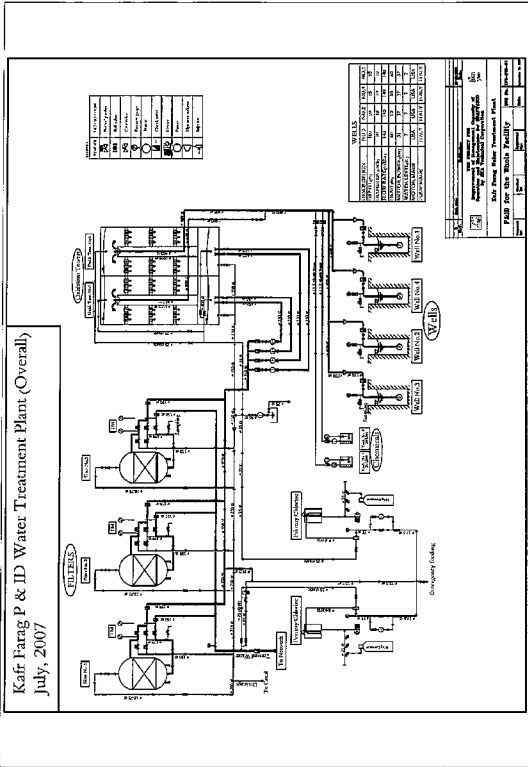

REINFORCEMENT ARRANGEMENT S=1:100
(Zogazig Water Treatment Plant ; No.1,2,3; NEW CHAMBER)

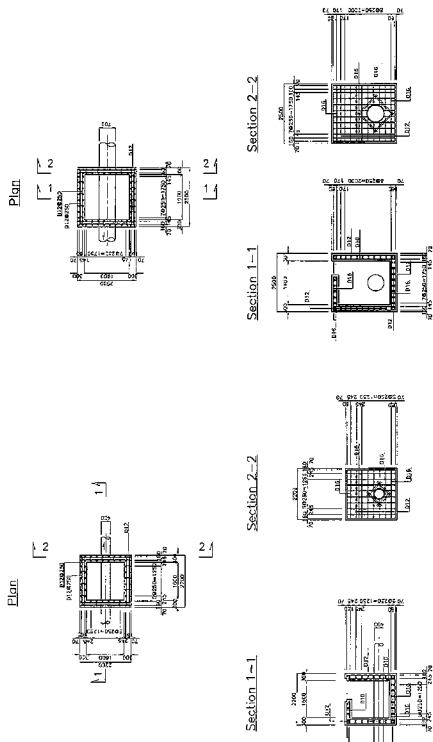

| REFERENCE DRAWING | | | |
|-------------------|---|------|----------------|
| TITLE | REINFORCEMENT DRAWING | DATE | SEPTEMBER 2007 |
| CREATOR | SHAWKA POTABLE WATER AND SANITATION COMPANY | | |

GENERAL DRAWING (2)
(Abbassa Water Treatment Plant and Abu Hommed Markaz)

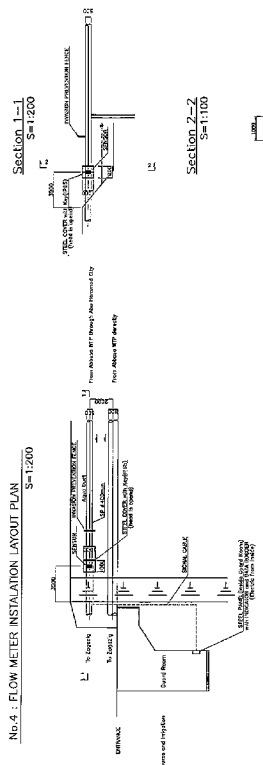

| REFERENCE DRAWING | | | |
|-------------------|---|------|----------------|
| TITLE | GENERAL DRAWING(2) | DATE | SEPTEMBER 2007 |
| CREATOR | SHAWKA POTABLE WATER AND SANITATION COMPANY | | |

GENERAL DRAWING (1)
(Abbassa Water Treatment Plant and Abu Hommed Markaz)

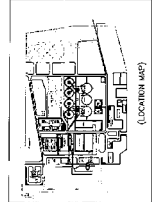

No.3 : FLOW METER INSTALLATION LAYOUT PLAN S=1:200

No.1 & 2 : FLOW METER INSTALLATION LAYOUT PLAN S=1:200

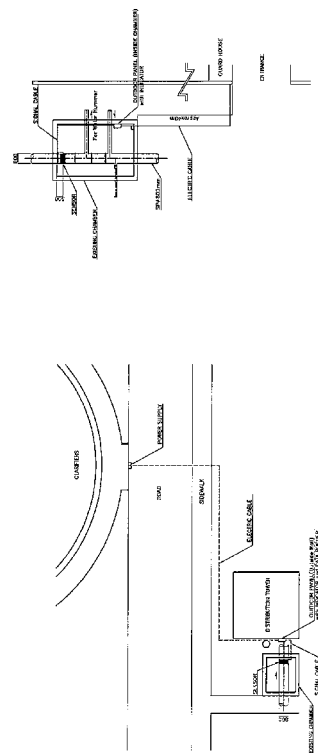

| REFERENCE DRAWING | | | |
|-------------------|---|------|----------------|
| TITLE | GENERAL DRAWING(1) | DATE | SEPTEMBER 2007 |
| CREATOR | SHAWKA POTABLE WATER AND SANITATION COMPANY | | |

GENERAL DRAWING (3)
(Abbassa Water Treatment Plant and Abu Hommed Markaz)

No.5 : FLOW METER INSTALLATION LAYOUT PLAN S=1:200

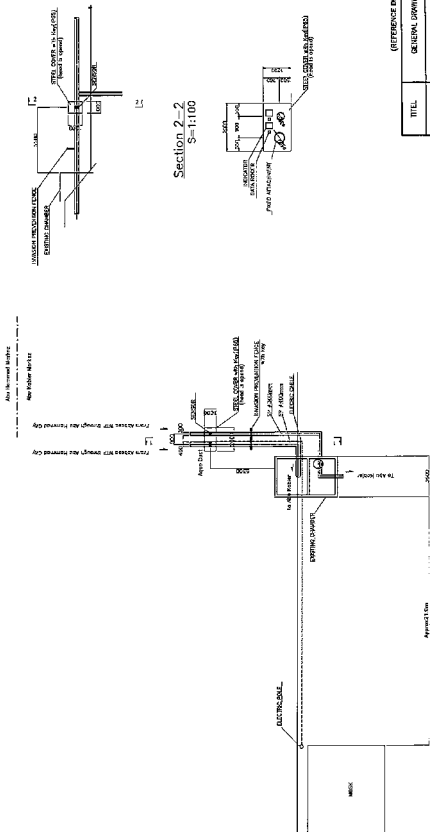

| REFERENCE DRAWING | | | |
|-------------------|---|------|----------------|
| TITLE | GENERAL DRAWING(3) | DATE | SEPTEMBER 2007 |
| CREATOR | SHAWKA POTABLE WATER AND SANITATION COMPANY | | |

GENERAL LAYOUT DRAWING S=1:500
(Husainia Water Treatment Station; No.1 EXISTING CHAMBER, No.2 : NEW CHAMBER)

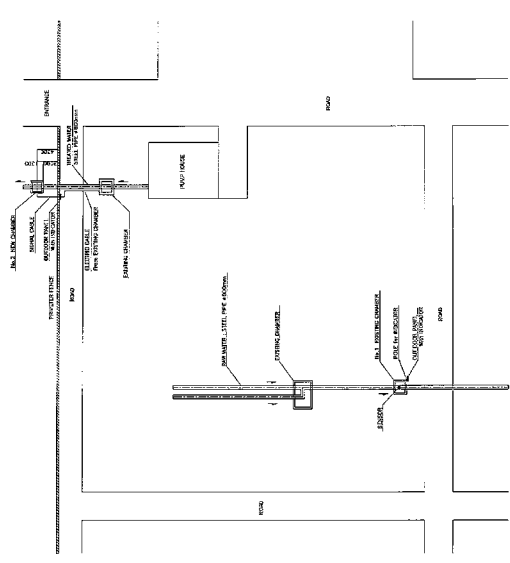

| REFERENCE DRAWING | |
|-------------------|--|
| TITLE | GENERAL LAYOUT DRAWING |
| DATE | SEPTEMBER 2007 |
| ORGANIZATION | SHANAWA POTABLE WATER AND SANITIZATION COMPANY |

GENERAL DRAWING (1)
(Korf Saqr Markoz; No.1 & No.2 :Flow Meter)

No.1 : FLOW METER INSTALLATION LAYOUT PLAN S=1:200

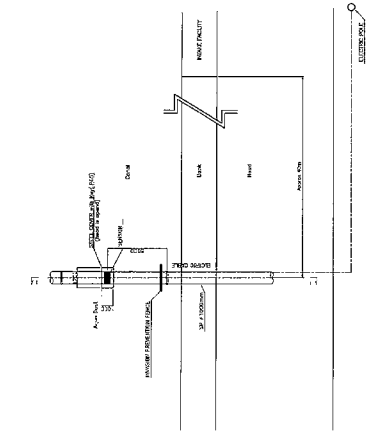

Section 1-1 S=1:200

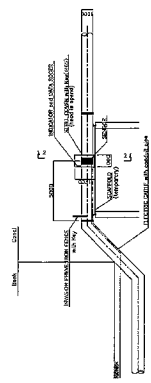

Section 2-2 S=1:100

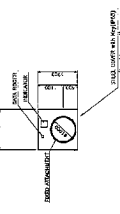

| REFERENCE DRAWING | |
|-------------------|--|
| TITLE | GENERAL DRAWING (1) |
| DATE | SEPTEMBER 2007 |
| ORGANIZATION | SHANAWA POTABLE WATER AND SANITIZATION COMPANY |

STRUCTURAL DRAWING S=1:100
(Husainia Water Treatment Plant; No.2 : NEW CHAMBER)

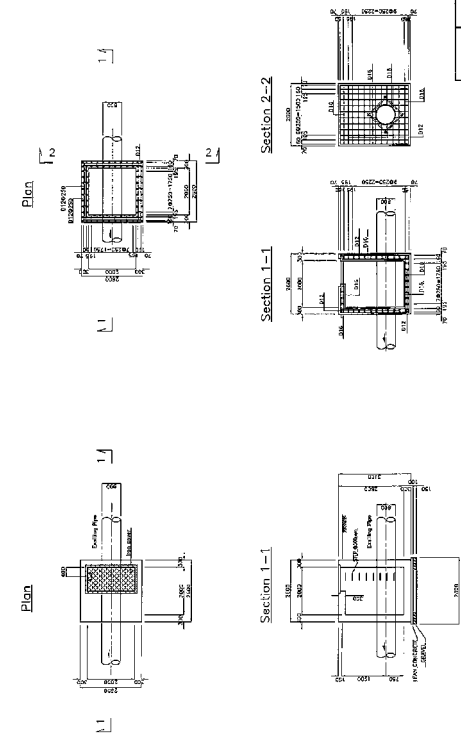

| REFERENCE DRAWING | |
|-------------------|--|
| TITLE | STRUCTURAL DRAWING |
| DATE | SEPTEMBER 2007 |
| ORGANIZATION | SHANAWA POTABLE WATER AND SANITIZATION COMPANY |

GENERAL DRAWING (2)
(Korf Saqr Markoz; No.1 & No.2 :Flow Meter)

No.2 : FLOW METER INSTALLATION LAYOUT PLAN S=1:200

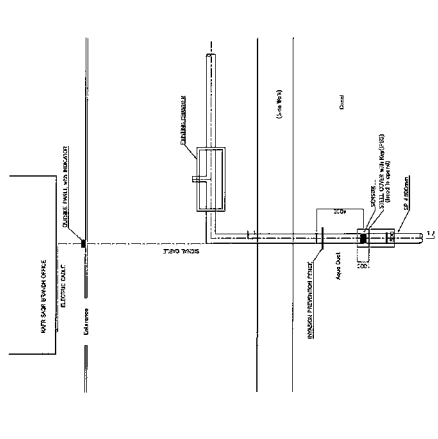

Section 1-1 S=1:200

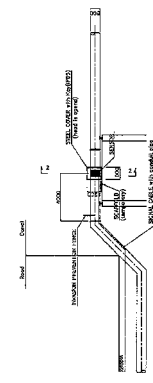

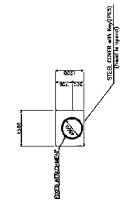

Section 2-2 S=1:100



| REFERENCE DRAWING | |
|-------------------|--|
| TITLE | GENERAL DRAWING (2) |
| DATE | SEPTEMBER 2007 |
| ORGANIZATION | SHANAWA POTABLE WATER AND SANITIZATION COMPANY |

The Project for Improvement of Management Capacity of
Operation and Maintenance for SHAPWASCO (Phase-2)

Minutes of Meeting for 13th Project Team Meeting for PH-2
MM-PTM2-13 [07.10.1]

| | | |
|------------|--|---|
| Date | 1 st October (Monday) 2007 | Signature |
| Time | 9:45~10:30 | |
| Place | SHAPWASCO chairman's room |  |
| Attendants | [SHAPWASCO : C/P] Eng. Alaa El Din Mohamed : Head of UFW/I/Q Team Eng. Abdel Shafi Abdel Aziz : Head of SOP/HQ Team Mr. Mohamed Osama Ahmed : Chemist, Head Office [Expert Team : The team] Mr. Keizo Kimura : SOP Activity Mr. Mitsuhiro Omori : Network Hydraulic Analysis Mr. Takashi Hara : Water Quality Control Mr. Mohamed Nagi : Facilitator | |
| | |  |

1. General

(1) Japanese Expert schedule

The team reported that the following Japanese expert will arrive at Egypt on the schedule mentioned below:

- Mr. Masatoshi Seno: To arrive at Egypt on 2nd October 2007

(2) Water conservation education activity

> Water conservation education activity should be conducted in October. Expert team already advised about this activity on 26th June.

- As the first step, SHAPWASCO has to select schools that may participate in the campaign activity.
- Next step, SHAPWASCO has to prepare the necessary materials in corporation with the Expert Team (Pamphlet, Questionnaires, Invitation letter, Sticker etc).

2. UFW reduction activity (progress of last week and issues to be addressed)

2-1. Progress

Actions U2, U4 and U8 have been conducted in the last week and summarized with the progress and the issues to be addressed as follows,

- (1) **Action U2** Conducting leakage (or MNF) survey for candidate sites

1

- > Remaining MNF survey are Area-1 & 2 of Zagazig City West where the permission for cutting new asphalt road is necessary.
- > SHAPWASCO did not get the permission, yet.

(2) **Action U4** Preparing GIS drawings

- > The updating works for Hihya city and inputting works for Hihya Markaz has been conducted.

(3) **Action U8** Measuring meter error of water meter

- The status of the meters had been surveyed and the number of non working meters had been determined according to the schedule which was submitted at previous PTM.

▲ SHAPWASCO did not start yet, and they will start the activity from this week.

2-2. Schedule for this week

Activity will be continued this week.

3. SOP activity (progress of last week and issues to be addressed)

3-1. Progress

Actions S1, S3, S4, S5, S9 and S10 have been conducted currently and summarized with the issues to be addressed as follows,

(1) **Action S1** Basic System Drawings

- > Eng. Hesham Gamal has conducted digitization of P&ID, electric single-line diagrams, layout and piping & cable route drawing of the model facilities and digitization of P&ID was finished. (Attachment U-1)

> Expert team will distribute digitized drawing of P&ID to be checked by model facilities staff.

- Situation of computer for model facilities which would prepare until 20th September.

▲ Hihya branch received the computer and other branch will proceed.

(3) **Action S3** Measurement/records of Raw and Treated Water Volume at Seven WTPs

- > Remaining drawings of new sixteen flow meters show the attachment U-2.

> No.3 flow meter in Abbasa WTP should be changed to one of the next sixteen flow meters which will arrive on December, because the location of Faqus Markaz was decided and this pipe material is asbestos and there is a possibility that next sixteen flow meters cannot measure asbestos pipe.

> Construction of flow meter chambers for the first five flow meters in Abbasa WTP is continued.

- Schedule of the mechanical/electrical installation work for flow meters shall be clarified.

2

(4) **Action S4** Development of SOPs for Model Facilities

- > Preparation of SOP documents has been conducted.

(5) **Action S5** SOP activities for Water Distribution Control in the Network

S5-1 Pilot Project for Distribution Control in Small Areas

- SHAPWASCO shall prepare the construction/installation works for five flow meters and four new chambers.

S5-2 Hydraulic analysis of water supply and distribution network

- > Preparation of analysis in Hihya Markaz has been conducted.
- > Ms. Heba was nominated as member of hydraulic analysis and training was started from today.

(6) **Action S9** Development of Water Quality Control System

- > A workshop of auditing system was held on the 27th September. The number of the attendance was 10 persons.
- > Progress for the Water Quality Control Programmes for Abbasa and Zagazig was reported.

(7) **Action S10** Well Monitoring

- > Well monitoring was started in Ibrahimiyah Markaz.

3-2. Schedule for this week

Above activity will be continued this week.

4. Attachment

Attachment S1: Digitization of P&ID

Attachment S2: Drawing for remaining sixteen flow meters

5. Next PTM

The team proposed to hold 14th PTM on Monday, 8th of October.

(End of MM)

3

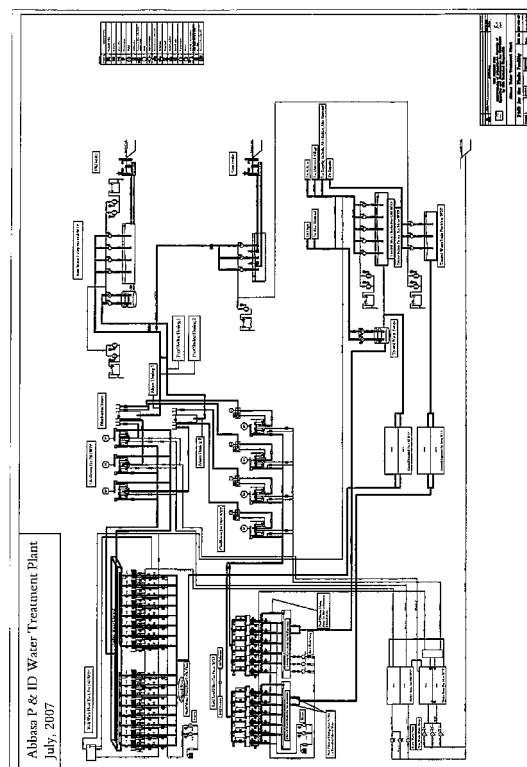

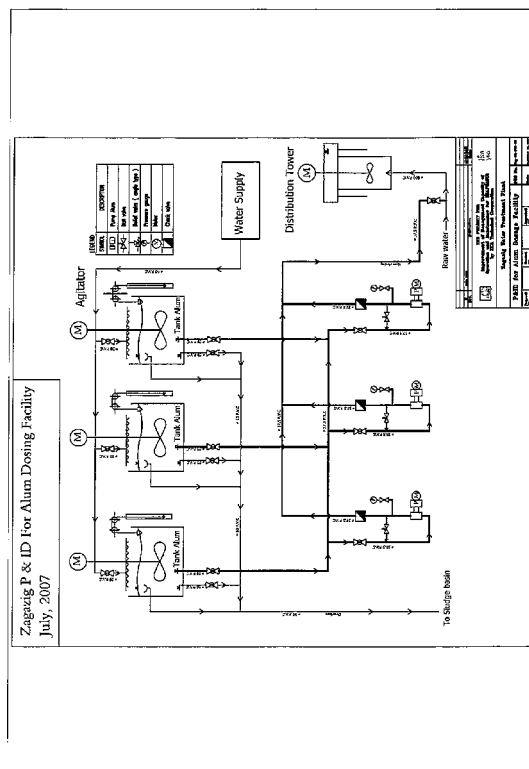
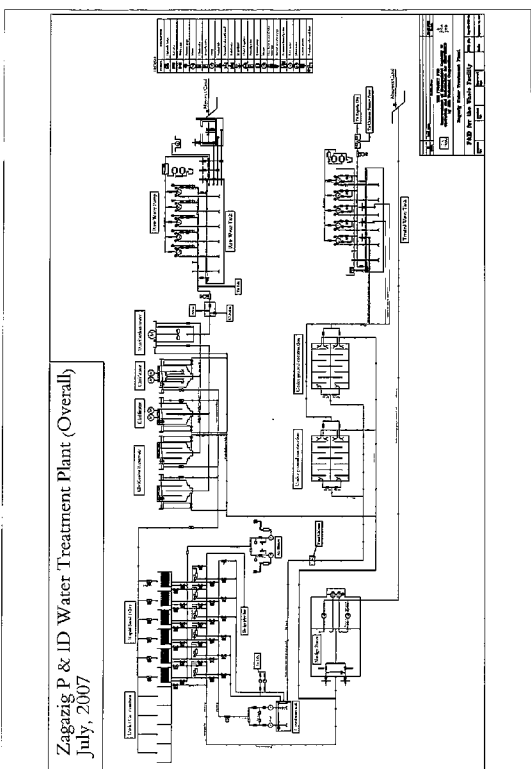
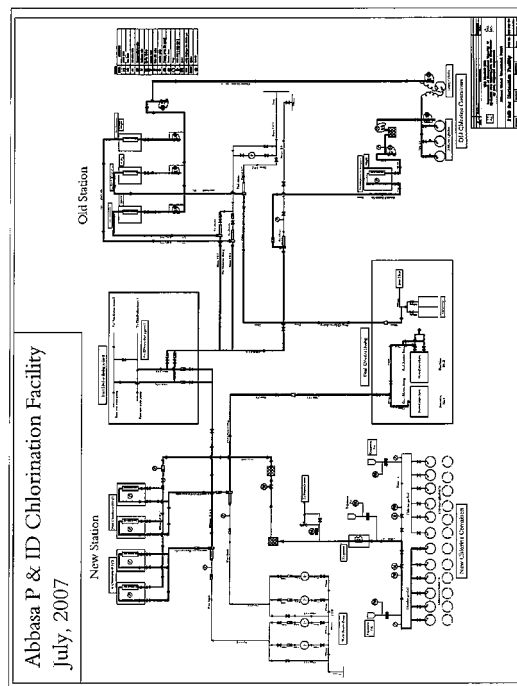
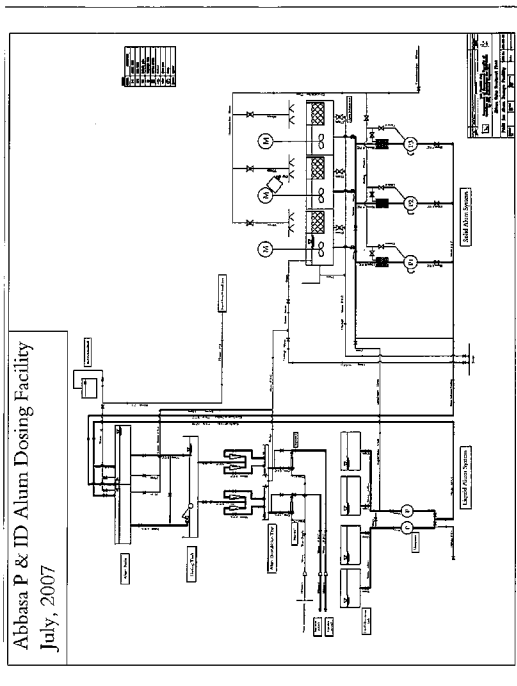

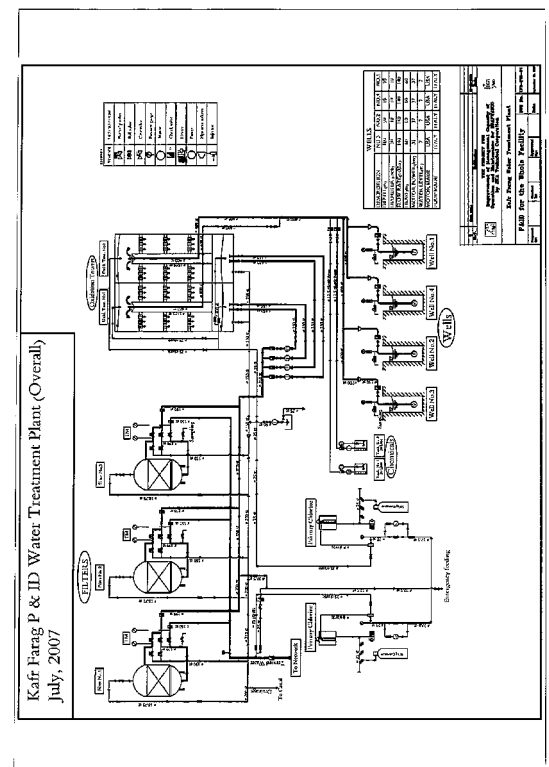
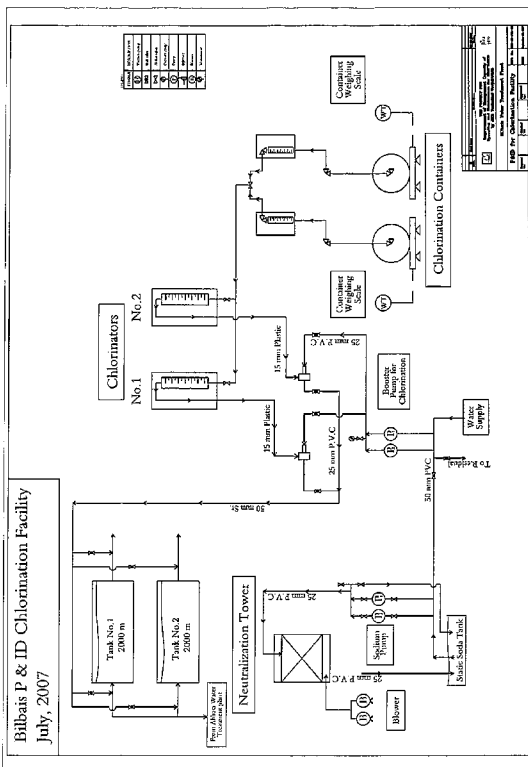
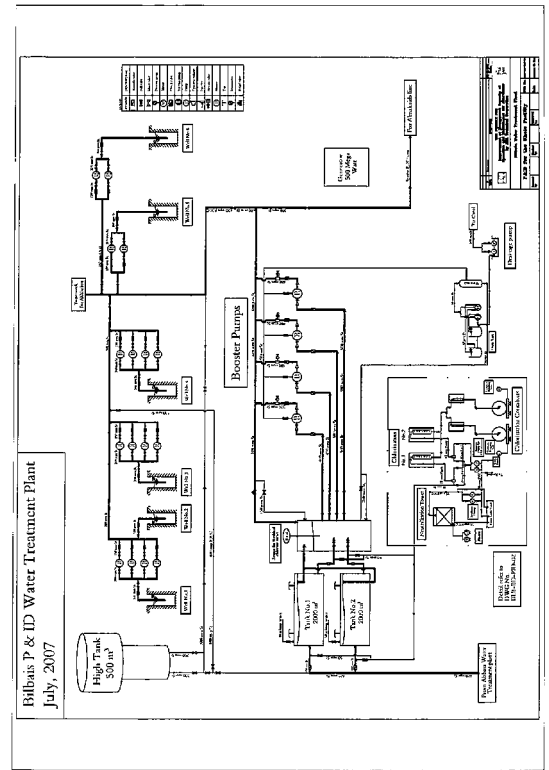
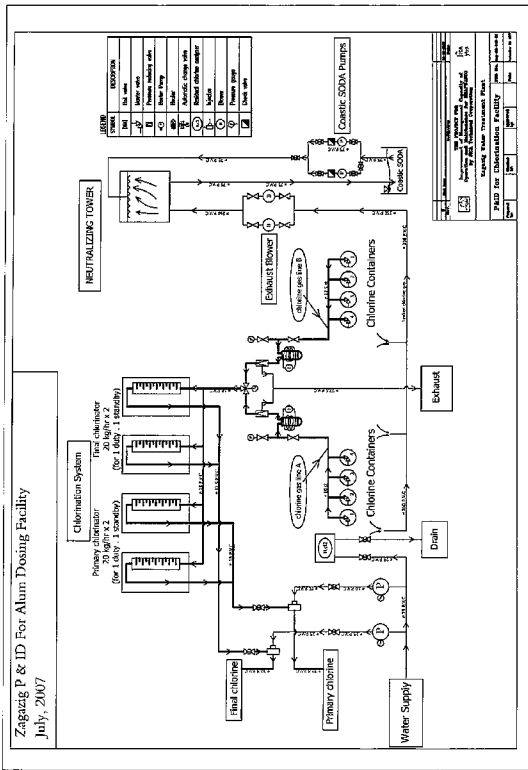

STRUCTURAL DRAWING S-1100
(Zogozig Water Treatment Plant : No.1,2,3: NEW CHAMBER)

No.1,2 (No.1: After Repairing)
Plan

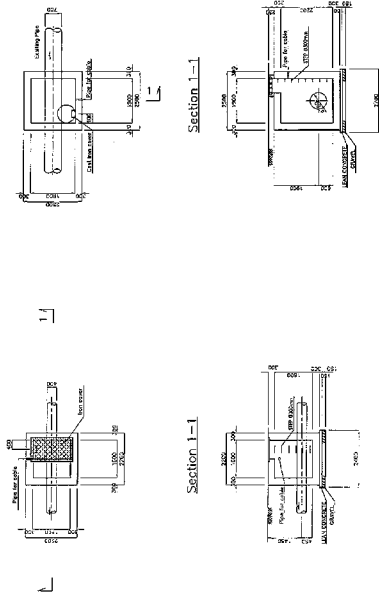

| REFERENCE DRAWING | |
|-------------------|---|
| TITLE | STRUCTURAL DRAWING |
| DATE | SEPTEMBER 2007 |
| DESIGNER | SHANGHAI FOSUN WATER AND SANITATION COMPANY |

No.3
Plan

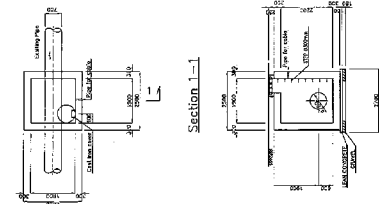

| REFERENCE DRAWING | |
|-------------------|---|
| TITLE | STRUCTURAL DRAWING |
| DATE | SEPTEMBER 2007 |
| DESIGNER | SHANGHAI FOSUN WATER AND SANITATION COMPANY |

REINFORCEMENT ARRANGEMENT S-1100
(Zogozig Water Treatment Plant : No.1,2,3: NEW CHAMBER)

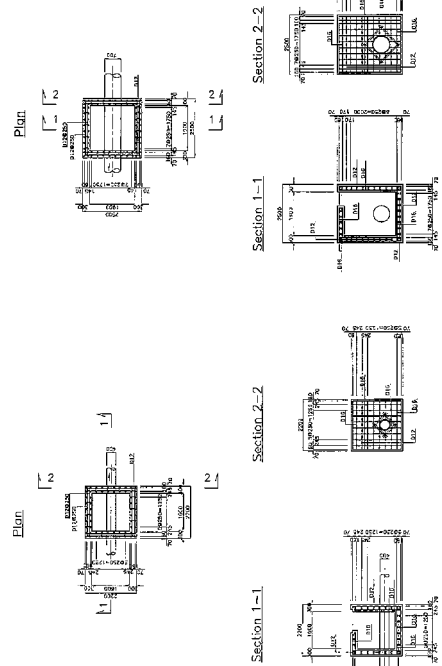

| REFERENCE DRAWING | |
|-------------------|---|
| TITLE | REINFORCEMENT DRAWING |
| DATE | SEPTEMBER 2007 |
| DESIGNER | SHANGHAI FOSUN WATER AND SANITATION COMPANY |

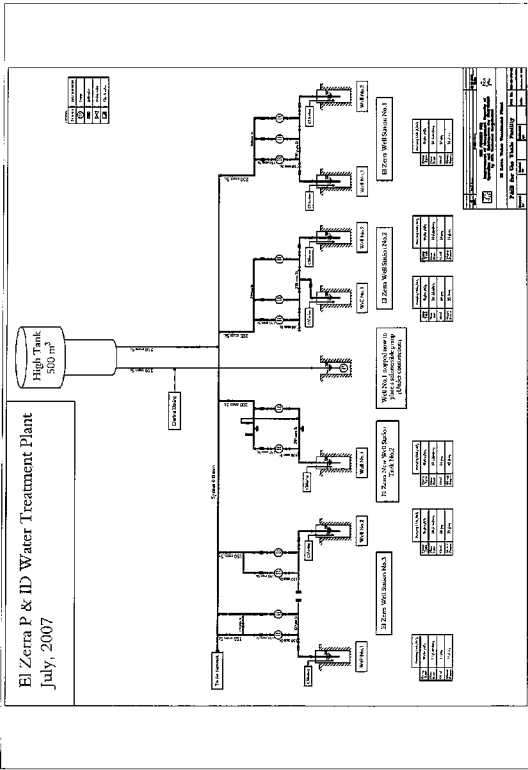

GENERAL LAYOUT DRAWING S-1100
(Zogozig Water Treatment Plant)

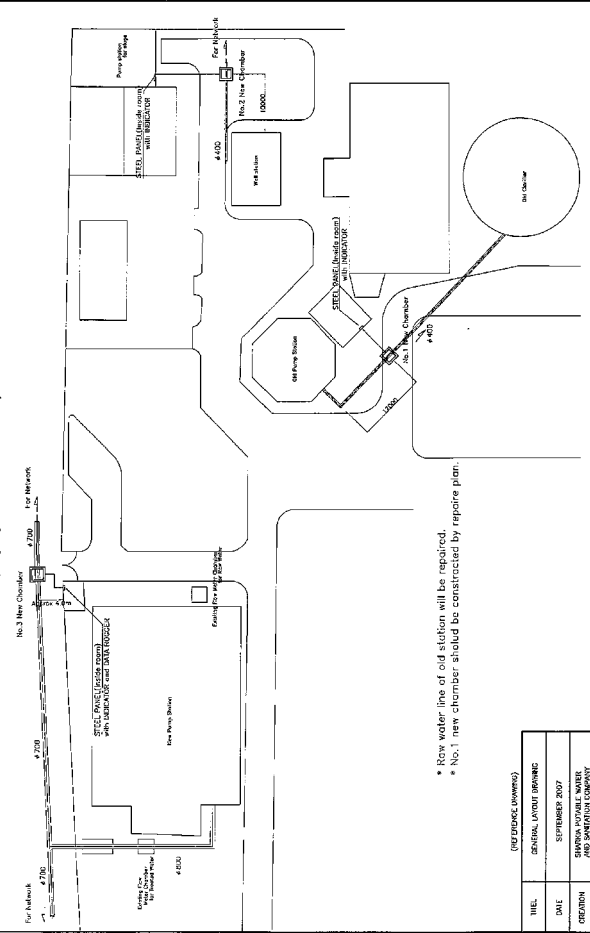

* Raw water line of old station will be repaired.
* No.1 new chamber should be constructed by repairing plan.

| REFERENCE DRAWING | |
|-------------------|---|
| TITLE | GENERAL LAYOUT DRAWING |
| DATE | SEPTEMBER 2007 |
| DESIGNER | SHANGHAI FOSUN WATER AND SANITATION COMPANY |

GENERAL DRAWING (3)
(Abhase Water Treatment Plant and Abu Hammad Markaz)

No.5 : FLOW METER INSTALLATION LAYOUT PLAN
S=1:200

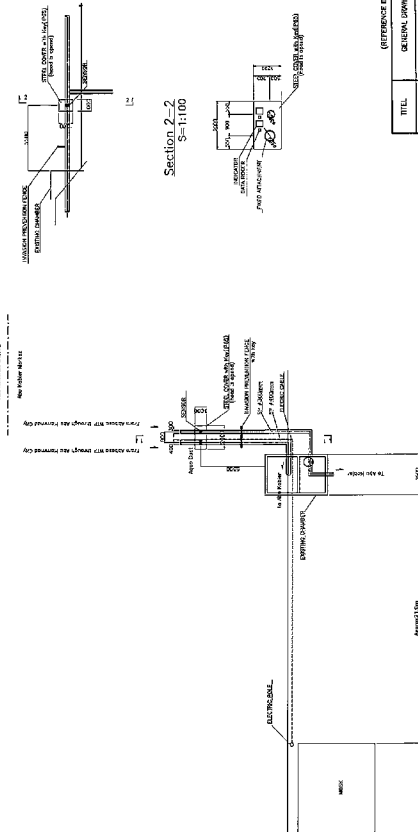

| REFERENCE DRAWING | |
|-------------------|--|
| TITLE | GENERAL DRAWING(3) |
| DATE | SEPTEMBER 2007 |
| CREATION | SHAWA POUSALE WATER AND SANITATION COMPANY |

GENERAL DRAWING (1)
(Abhase Water Treatment Plant and Abu Hammad Markaz)

No.1 & 2 : FLOW METER INSTALLATION LAYOUT PLAN
S=1:200

No.3 : FLOW METER INSTALLATION LAYOUT PLAN
S=1:200

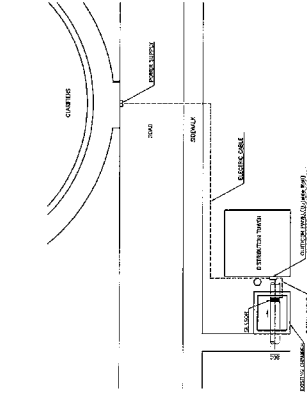

| REFERENCE DRAWING | |
|-------------------|--|
| TITLE | GENERAL DRAWING(1) |
| DATE | SEPTEMBER 2007 |
| CREATION | SHAWA POUSALE WATER AND SANITATION COMPANY |

GENERAL LAYOUT DRAWING (S=1:250)
(Fogus Markaz; No.1 NEW CHAMBER)

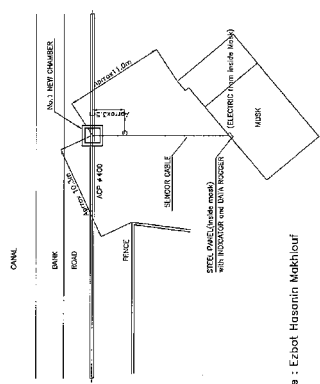

Area Name : Ezabot Hussein Makhloof

| REFERENCE DRAWING | |
|-------------------|--|
| TITLE | GENERAL LAYOUT DRAWING |
| DATE | SEPTEMBER 2007 |
| CREATION | SHAWA POUSALE WATER AND SANITATION COMPANY |

GENERAL DRAWING (2)
(Abhase Water Treatment Plant and Abu Hammad Markaz)

No.4 : FLOW METER INSTALLATION LAYOUT PLAN
S=1:200

Section 1-1
S=1:200

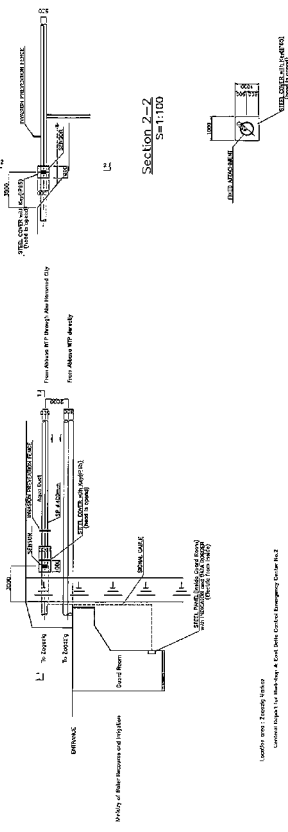

| REFERENCE DRAWING | |
|-------------------|--|
| TITLE | GENERAL DRAWING(2) |
| DATE | SEPTEMBER 2007 |
| CREATION | SHAWA POUSALE WATER AND SANITATION COMPANY |

STRUCTURAL DRAWING S=1:100
(Focus Markaz : No.1: NEW CHAMBER)

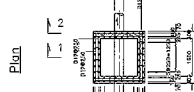
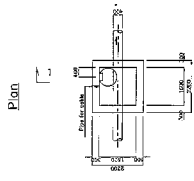

Section 1-1

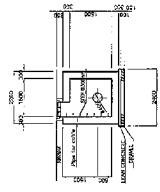

Section 1-1

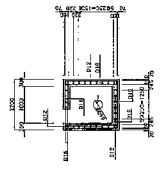

Section 2-2

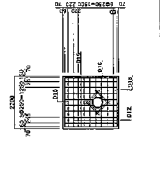

| (REFERENCE DRAWING) | |
|---------------------|---|
| TITLE | STRUCTURAL DRAWING |
| DATE | SEPTEMBER 2007 |
| DESIGNER | SHARAW POKHARE WATER AND SANITATION COMPANY |

1) Piping depth should not be less than 100 mm in the form of slabs.
2) Section which shown is drawn by using scale of 1:100 and depth not by the reference.

STRUCTURAL DRAWING S=1:100
(Old Faouja Water Treatment Plant; No. 1, 2: NEW CHAMBER)

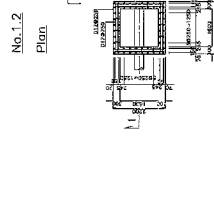
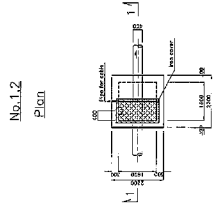

Section 1-1

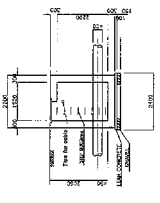

Section 1-1

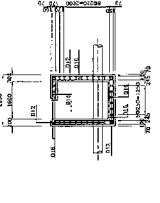

Section 2-2

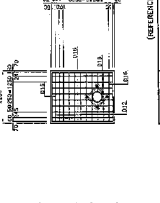

| (REFERENCE DRAWING) | |
|---------------------|---|
| TITLE | STRUCTURAL DRAWING |
| DATE | SEPTEMBER 2007 |
| DESIGNER | SHARAW POKHARE WATER AND SANITATION COMPANY |

1) Piping depth should not be less than 100 mm in the form of slabs.
2) Section which shown is drawn by using scale of 1:100 and depth not by the reference.

GENERAL LAYOUT DRAWING S=1:250
(Old Faouja Water Treatment Station; No.1, No.2 : NEW CHAMBER)

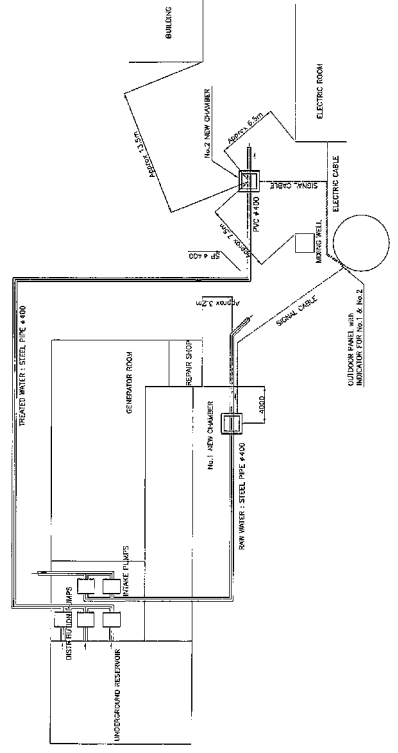

| (REFERENCE DRAWING) | |
|---------------------|---|
| TITLE | GENERAL LAYOUT DRAWING |
| DATE | SEPTEMBER 2007 |
| DESIGNER | SHARAW POKHARE WATER AND SANITATION COMPANY |

GENERAL LAYOUT DRAWING S=1:500
(Husheh'a Water Treatment Station; No.1 EXISTING CHAMBER, No.2: NEW CHAMBER)

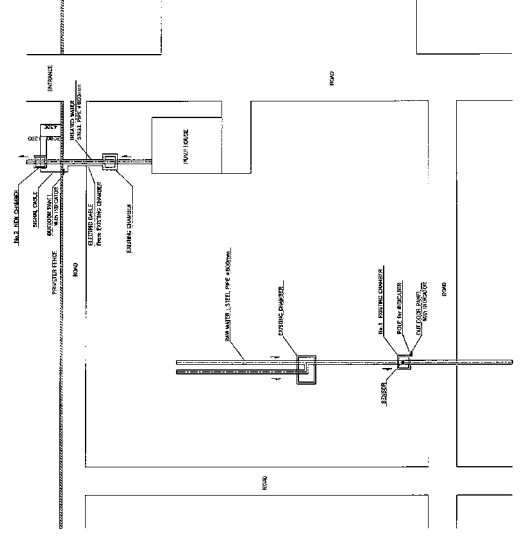

1) Refer to the existing layout drawing.
2) Electric cable should be kept in the existing condition.

| (REFERENCE DRAWING) | |
|---------------------|---|
| TITLE | GENERAL LAYOUT DRAWING |
| DATE | SEPTEMBER 2007 |
| DESIGNER | SHARAW POKHARE WATER AND SANITATION COMPANY |

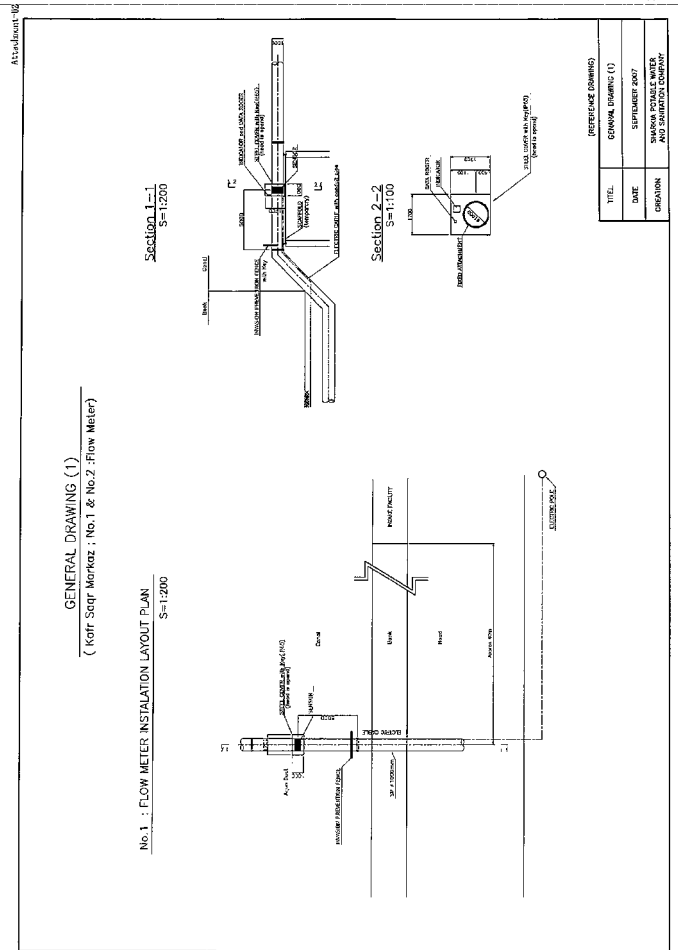
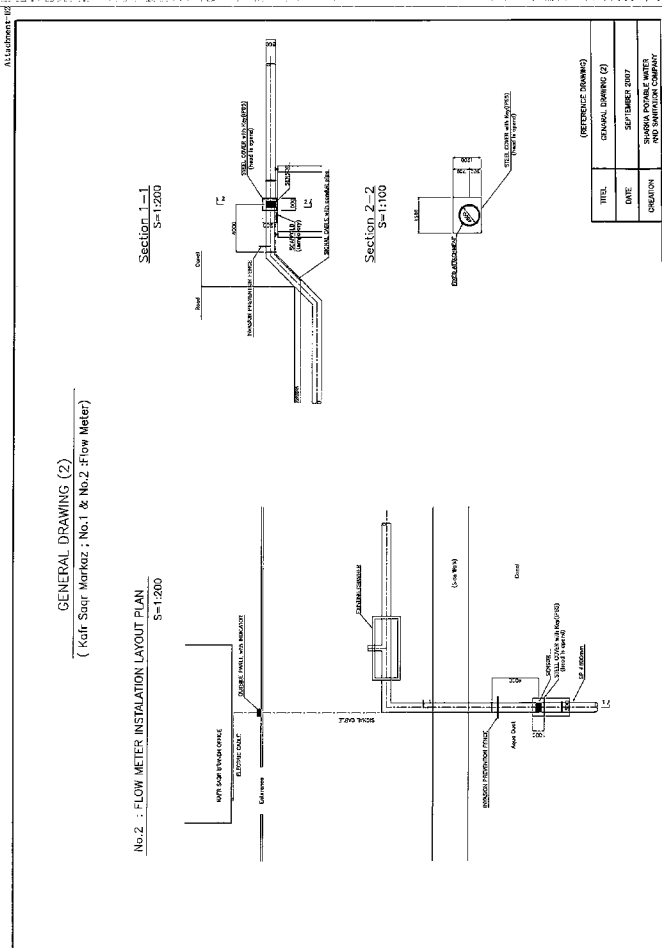
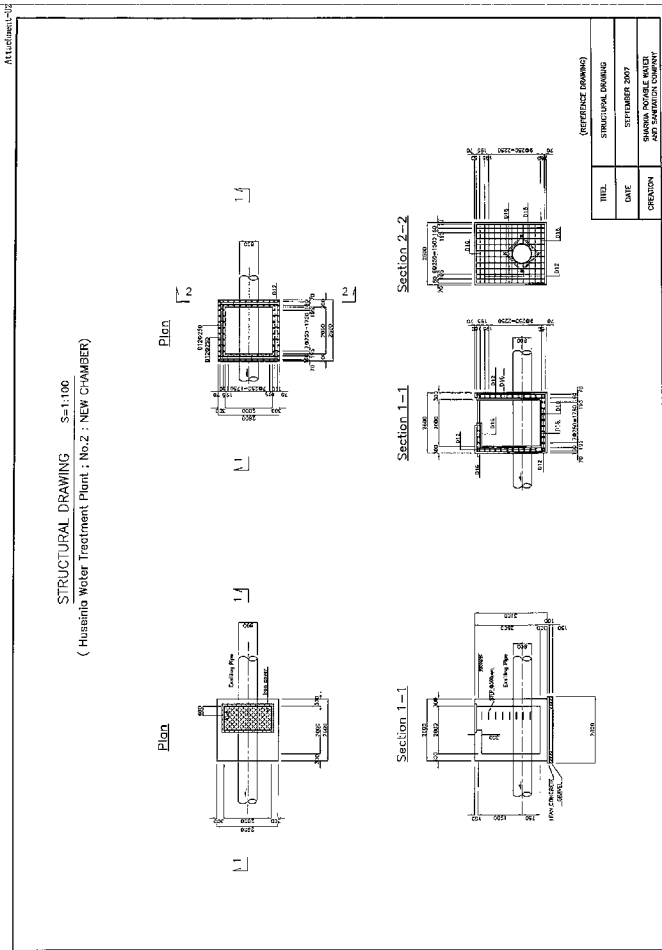

MM-PTM2-14 (1/4)

The Project for Improvement of Management Capacity of Operation and Maintenance for SHAPWASCO (Phase-2)

Minutes of Meeting for 14th Project Team Meeting for PH-2
MM-PTM2-14 [07.10.8]

| | | |
|------------|--|---|
| Date | 8 th October (Monday) 2007 | Signature |
| Time | 10:30~11:30 | |
| Place | SHAPWASCO chairman's room |  |
| Attendants | [SHAPWASCO : C/P] Eng. Alae El Din Mohamed : Head of UFW/HQ Team Eng. Abdel Shafi Abdel Aziz : Head of SOP/HQ Team Mr. Mohamed Osama Ahmed : Chemist, Head Office | |
| | [Expert Team : The team] Mr. Masatoshi Seno : UFW Reduction Mr. Keizo Kimura : SOP Activity Mr. Mitsuhiro Omori : Network Hydraulic Analysis Mr. Takashi Hara : Water Quality Control Mr. Mohamed Nagi : Facilitator | |

I. General

(1) Japanese Expert schedule

The Team reported the schedule of the following Japanese Expert.

- Mr. Masatoshi Seno : Arrived on the 2nd October 2007
- Mr. Mitsuhiro Omori : To leave on the 15th October 2007
- Mr. Masahiro Takeuchi : To arrive on the 17th October 2007

(2) Water Conservation & Education Activity

The Team explained the progress of the water saving & education activity.

- Water conservation & education activity should be conducted in October. The Team advised the course of the activity on the 26th June.
- The Team held a meeting with the person in charge in SHAPWASCO and agreed the following points;
 - SHAPWASCO will select the school before the 11th October.
 - The Team will prepare some materials such as leaflet for assisting SHAPWASCO's activity. The draft version will be submitted before the 11th October.

2. UFW reduction activity (progress of last week and issues to be addressed)

2-1. Progress

The Team explained that Action 6, 7, 8, 9 and 10 for P2 (for Hihya) for the UFW activity shall be commenced from October, 2007, according to the Implementation Schedule (Attachment U1).

Actions U2, U4, U7 and U8 have been conducted in the last week and summarized with the progress and the issues to be addressed as follows,

- (1) **Action U2** Conducting leakage (or MNF) survey for candidate sites
 - The remaining MNF survey is Area-1 & 2 of Zagazig City West where the permission for cutting new asphalt road is necessary.
 - SHAPWASCO did not get the permission, yet. SHAPWASCO is required to clarify the date expected to obtain the permission.
 - ▲ Eng. Alae El Din Mohamed responded he will urgently take any necessary procedure for obtaining the permission through the Chairman.
- (2) **Action U4** Preparing GIS drawings
 - The updating works for Hihya city (Area-1 and Area-2) and inputting works for Hihya Markaz (Area-3, 4 and 5) has been conducted.
 - Expert Team explained that the location of the pipelines for Zagazig Markaz, Ibrahimiya Markaz and Diarb Nigm Marka shall be drawn on the GIS base maps prior to inputting works of GIS drawings, which is necessary to adjust to the sketch of the pipelines
- (3) **Action U7** Surveying installation conditions of water meters
 - The following data for Area-1, 2, 3, 4 and 5 of Hihya have to be surveyed by the Customer Service of Hihya to determine the Pilot Project Area:
 - Numbers of house connection
 - Numbers of working meters
 - Numbers of non working meters
 - ▲ Eng. Alae El Din Mohamed and the person from Hihya Branch responded these data will be prepared by the 11th October (Thursday).
- (4) **Action U8** Measuring meter error of water meter
 - SHAPWASCO is requested to replace non working meters in the Zagazig East Area-1
 - ▲ All replacement shall be commenced by the 25th October (Thursday) under Eng. Alae El Din Mohamed's supervision.

2-2. Schedule for this week

- Activity will be continued this week based on the schedule which was submitted at previous PTM.

3. SOP activity (progress of last week and issues to be addressed)

3-1. Progress

Actions S1, S3, S4, S5, S9 and S10 have been currently conducted and are summarized with the issues to be addressed as follows,

- (1) **Action S1** Basic System Drawings
 - Eng. Hesham Gamal has conducted digitization of P&ID, electric single-line diagrams, layout and piping & cable route drawing of the model facilities.
 - The Team and the Counterpart Team distributed P&ID drawings to model facilities and requested the facility operators to revise them until the end of the 3rd week of October.
 - Activity of digitizing of the general layout drawing has been in progress.
 - The Team distributed the digitized drawings of P&ID to the plant manager of the model facilities. The first version of P&ID for the model facilities will be issued by the Team after revision by the person in the model facilities.
 - The Team will distribute digitized drawings when the computers are supplied.
 - The Team inquired the situation of the computers for the model facilities.
 - ▲ Eng. Abdel Shafi Abdel Aziz explained the supplied computers have already been deployed at the model facilities except Zelaa due to lack of security at the station. For improvement security, some work including equipment of windows and locked doors will be implemented by the 25th October (Thursday) under the supervision by Eng. Abdel Shafi Abdel Aziz. The computer will be deployed after its improvement work.
- (2) **Action S3** Measurement/records of Raw and Treated Water Volume at Seven WTPs
 - The construction work of flow meter chambers for the first five flow meters in Abbasa WTP has been continued.
 - The Team inquired the schedule of the mechanical/electrical installation work for flow meters shall be clarified.
 - ▲ Eng. Abdel Shafi Abdel Aziz explained the contract of the work with a contractor has already been commenced. Eng. Abdel Shafi Abdel Aziz will supervise the progress of the work and report at the next meeting.

(3) Action S4 Development of SOPs for Model Facilities

- Activity of making of SOP documents for ABBASA WTP is in progress.

- (5) **Action S5** SOP activities for Water Distribution Control in the Network
 - S5-1 Pilot Project for Distribution Control in Small Areas
 - SHAPWASCO shall prepare the construction/installation works for five flow meters and four new chambers.
 - S5-2 Hydraulic analysis of water supply and distribution network
 - Ms. Heba studied basic operation for water cad and she has analyzed Zagazig city east.
 - Analysis in Hihya Markaz has been conducted by Mr. Badawi, Mr. Mahady and Ms.Heba.
- (6) **Action S9** Development of Water Quality Control System
 - An internal audit was conducted at Hihya Laboratory to check and assess its laboratory and analytical environment on the 4th October.
 - Auditing for Abbasa Laboratory is scheduled on the 9th October.
 - The date for execution of auditing for Zagazig Laboratory is to be announced soon.
 - Water Quality Control Programmes for Abbasa and Zagazig have been elaborated and their completion is expected in this week.
- (7) **Action S10** Well Monitoring
 - Well monitoring was started in Ibrahimiya Markaz.

3-2. Schedule for this week

Above activity will be continued this week.

4. Attachment

Attachment U1: Implementation Schedule

5. Next PTM

The Team proposed to hold the 15th PTM on Sunday, 21st of October.

(End of MM)

Attachment U1

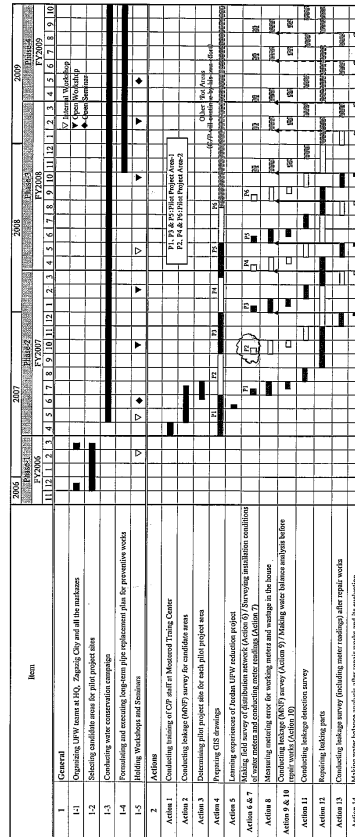

Source : Prepared by CPT team and JICA expert team

- P1:Zagazig East
- P2:Hihya
- P3:Zagazig West
- P4:Ibrahimiya Markaz
- P5:Zagazig Markaz
- P6:Diarb Nigm Markaz

Implementation Schedule for UFW Reduction Activity

- SHAPWASCO shall do tendering procedures for the construction/installation works of four new chambers of flow meters.

S5-2 Hydraulic analysis of water supply and distribution network

- Ms. Heba studied basic operation for water cad and she has analyzed Zagazig city east.
- Analysis in Hihya Markaz has been conducted by Mr. Badawi, Mr. Mahaady and Ms. Heba.

(6) Action S9 Development of Water Quality Control System

- Water Quality Control Programmes for Abassa and Zagazig have been elaborated.

(7) Action S10 Well Monitoring

- Well monitoring was started in Ibrahimiya Markaz. Ms. Heba will assist Mr. Gamal Abd El Hameed in computer data inputting of well monitoring results from the 20th October.

3-2. Schedule for this week

Above activities will be continued this week.

4. Handing-over of New Faqus WTP

The Team inquired the progress for handing over of New Faqus water treatment plant.

- SHAPWASCO explained that handing over of New Faqus will be on January, 2008.

5. Open Workshop

The Team proposed to have an open workshop to make a presentation of the achievements in the activities so far and make discussions with other water company's staff around the end of November 2007.

- C/P agreed with the Team and proposed to have it between 22nd and 26th November in Zagazig.
- ▲ The Team understand C/P proposal and will decide the detailed contents as soon as possible.

6. Next PTM

The Team proposed to hold the 16th PTM on Sunday, 29th of October.

(End of MM)

4

Sector and Stores of SHAPWASCO to take the routine procedures to replace 266 water meters within two weeks.

2-2. Schedule for this week

- Activities will be continued this week based on the schedule which was submitted at previous PTM.

3. SOP activity (progress of last week and issues to be addressed)

3-1. Progress

Actions S1, S3, S4, S5, S9 and S10 are being conducted and the issues are summarized as follows;

(1) Action S1 Basic System Drawings

- Eng. Hesham Gamal has conducted digitization of P&ID, electric single-line diagrams, layout and piping & cable route drawing of the model facilities.
- The Team and the Counterpart Team distributed P&ID drawings to model facilities and requested the facility operators to revise them until the end of the 3rd week of October.
- Activity of digitizing of the general layout drawing has been in progress.
- The Team will distribute digitized drawings when the computers are supplied.
- The Team inquired the situation of the computers for the model facilities.

(2) Action S3 Measurement/records of Raw and Treated Water Volume at Seven WTPs

- The construction work of flow meter chambers for the first five flow meters in Abassa WTP has been continued.
- The schedule of the mechanical/electrical installation work for flow meters shall be clarified.
- ▲ Eng. Abdel Shafi Abdel Aziz explained the content of the work to the contractor. Eng. Abdel Shafi Abdel Aziz will supervise the progress of the work and report at the next PTM.
- ▲ The Chairman issued his instruction to Eng. Abdel Shafi Abdel Aziz to finalize the necessary tendering procedures for the remaining 15 sites. Eng. Abdel Shafi will report the progress at the next PTM.

(3) Action S4 Development of SOPs for Model Facilities

- Activity of preparing SOP documents for Abassa WTP is in progress.

(5) Action S5 SOP activities for Water Distribution Control in the Network

- S5-1 Pilot Project for Distribution Control in Small Areas

3

students (around 30 students) on 28th October and let them understand how drinking water is produced, and distribute the post questionnaire to the students on the same day (after the site tour).

2. UFW reduction activity (progress of last week and issues to be addressed)

2-1. Progress

Actions U2, U4, U7 and U8 have been conducted in the last week and the progress and the issues are summarized as follows,

(1) Action U2 Conducting leakage (or MNF) survey for candidate sites

- The remaining MNF survey is Area-1 & 2 of Zagazig City West where the permission for cutting new asphalt road is necessary.

- SHAPWASCO has not got the permission yet. SHAPWASCO is required to clarify the date expected to obtain the permission.

- ▲ Based on the Chairman arrangements, Eng. Alae El Din Mohamed met with the Head of District on 20th October 2007 and they visited the site. The Head of District agreed to issue the permission for the two sites and requested SHAPWASCO to issue a new request letter. SHAPWASCO prepared the letter and will submit it to the District on 21st October 2007. It is expected for C/P to receive the permission on 23rd October and to start implementation on 24th October. This matter shall be followed by Mr. Alae.

(2) Action U4 Preparing GIS drawings

- Updating works for Hihya city (Area-1 and Area-2) and data inputting works for Hihya Markaz (Area-3, 4 and 5) have been conducted.

(3) Action U7 Surveying installation conditions of water meters

- The following data for Area-1, 2, 3, 4 and 5 of Hihya have to be surveyed by the Customer Service of Hihya to determine the Pilot Project Area:

- Numbers of house connection
- Numbers of working meters
- Numbers of non working meters

- ▲ Eng. Alae El Din Mohamed stated that these data has been prepared as scheduled on 11th October (Thursday).

(4) Action U8 Measuring metering error of water meters

- SHAPWASCO is requested to replace non working meters in the Zagazig East Area-1.

- ▲ The Chairman confirmed that there is enough number of water meters in SHAPWASCO's stores. Instructions have been made on 20th October to Commercial

2

The Project for Improvement of Management Capacity of Operation and Maintenance for SHAPWASCO (Phase-2)

Minutes of Meeting for 15th Project Team Meeting for PH-2

MM-PTM2-15 [07.10.20]

| Date | 20 th October (Saturday) 2007 | Signature |
|------------|--|-----------|
| Time | 8:30~10:00 | |
| Place | SHAPWASCO chairman's room | |
| Attendants | [SHAPWASCO : C/P] Eng. Alae El Din Mohamed : Head of UFW/HQ Team Eng. Abdel Shafi Abdel Aziz : Head of SOP/HQ Team Mr. Mohamed Osama Ahmed : Chemist, Head Office | Eng. Alae |
| | [Expert Team : The team] Mr. Masahiro Takeuchi : Team Leader Mr. Masatoshi Seno : UFW Reduction Mr. Keizo Kimura : SOP Activity Mr. Takashi Hara : Water Quality Control Mr. Mohamed Nagi : Facilitator Mr. Mahmoud Abu Khalaf : Senior Engineer for SOP | |

1. General

(1) Japanese Expert schedule

The Team reported the schedule of the following Japanese Expert.

- Mr. Mitsuhiro Omori : Left on the 15th October 2007
- Mr. Masahiro Takeuchi : Arrived on the 17th October 2007

(2) Water Conservation & Education Activity

The Team explained the progress of the water saving & education activity.

- Water conservation & education activity should be started in October. The Team has been advising the contents of the activity since this May.

- The Team held a meeting with the person in charge in SHAPWASCO and agreed the following points;

- The Team prepared some draft materials such as leaflet, pre questionnaire and post questionnaire for assisting SHAPWASCO's activity. The draft has been approved by SHAPWASCO.

- SHAPWASCO will arrange a visit to a primary school in Abu Hatab village of Hihya Markaz named El Shaheed Nabil Abass on 24th October and distribute the pre questionnaire on the same day.

- SHAPWASCO will arrange a site tour to Hihya water treatment plant by the school

1

The Project for Improvement of Management Capacity of
Operation and Maintenance for SHAPWASCO (Phase-2)

Minutes of Meeting for 16th Project Team Meeting for PH-2
MM-PTM2-16 [07.10.31]

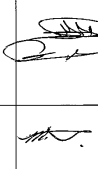
| | | |
|------------|---|---|
| Date | 31 st October (Wednesday) 2007 | Signature |
| Time | 15:00~16:00 | |
| Place | SHAPWASCO chairman's room | |
| Attendants | <p>[SHAPWASCO : C/P]</p> <p>Eng. Alae El Din Mohamed : Head of UFW/HQ Team Eng. Abdel Shafi Abdel Aziz : Head of SOP/HQ Team Mr. Mohamed Osama Ahmed : Chemist, Head Office Eng. Gamal Abd El Hameed Morsi : Well Stations Dept. Eng. Wala Mohamed Ali : UFW/HQ Team</p> <p>[Expert Team : The team]</p> <p>Mr. Masahiro Takeuchi : Team Leader Mr. Masatoshi Seno : UFW Reduction Mr. Mohamed Nagi : Facilitator</p> |  |

1. General

(1) Japanese Expert schedule

The team reported that the following Japanese experts left Egypt as scheduled;

- Mr. Keizo Kimura: 29th October 2007
- Mr. Takashi Hara : 30th October 2007

The team also reported that the following Japanese experts will arrive in Egypt on the schedule mentioned below;

- Mr. Akihiko Okazaki : 6th November 2007
- Mr. Noboru Saeki : 16th November 2007

(2) Water conservation education activity

➢ First activity for water conservation education campaign was done successfully from 24th to 28th October. The students and teachers from El Shaheed Nabil Abass primary school participated in the activity.

➢ Expert team requested C/P to expand their activity to other schools and/or residents in the Governorate from now on.

- SHAPWASCO will make a detailed plan and schedule for further activity within two weeks.

1

2. UFW reduction activity (progress of last week and issues to be addressed)

2-1. Progress

Actions U2, U3, U4, U7 and U8 have been conducted this week. The progress and the issues are summarized as follows,

- (1) **Action U2** Conducting leakage (or MNF) survey for candidate sites
 - The remaining MNF survey is Area-1 & 2 of Zagazig City West where the permission for cutting new asphalt road is necessary.
 - SHAPWASCO has received the permission of the construction of pit on 21st October 2007. The construction of pit has been started from 22nd October and will be completed within this week.
- (2) **Action U3** Determining pilot project site for each pilot project area
 - Action U3 has been conducted for Hihya Markaz (Area-2). 'South-eastern area of Hihya City' has been selected as the pilot area. For the details, see Attachment-1.
- (3) **Action U4** Preparing GIS drawings
 - Updating works for Hihya city (Area-1 and Area-2) have been completed and the draft of networks on GIS drawings for Hihya Markaz (Area-3, 4 and 5) will be delivered to the site office to be checked this week.
- (4) **Action U7** Surveying installation conditions of water meters
 - The following data for Area-1, 2, 3, 4 and 5 of Hihya have been surveyed by the Customer Service of Hihya branch to determine the Pilot Project Area and the result is shown in **Attachment-1**;
 - Numbers of house connection
 - Numbers of working meters
 - Numbers of non working meters
 - Detailed survey of non-working meters for the selected area will be started from 5th November.
- (5) **Action U8** Measuring metering error of water meters and wastage in the house
 - 1) SHAPWASCO is requested to replace non working meters in Zagazig East Area-1.
 - ▲ The number of stocked water meters is about 1,000pcs at SHAPWASCO's stores. Commercial Sector and Stores of SHAPWASCO started necessary procedures to replace about 260 water meters. The replacement of non-working meters will be started next week.
 - 2) The survey for the consumption during midnight hours in the house in Hihya area-2 was started this week.

2-2. Schedule for the next week

UFW reduction activities will be continued in the next week as scheduled.

2

3. SOP activity (progress of last week and issues to be addressed)

3-1. Progress

Actions S1, S3, S4, S5, S9 and S10 have been conducted this week. The progress and the issues are summarized as follows;

(1) Action S1 Basic System Drawings

- Eng. Hesham Gamal has completed digitization of P&ID and layout and piping. Electric single-line diagrams have been conducted for model facilities while cable route drawing of the model facilities not started yet.
- Expert team and counterpart team distributed P&ID drawing to model facilities and asked them to check it until 1st November 2007.
- Activities of digitizing of the general layout drawings for model facilities have been completed.
- The first version of P&ID for the model facility will be issued by expert team after check by the person in the model facility.
- Model Facilities have completed receipt of computers on 30th October 2007. Expert team will distribute digitized drawing one by one.

(2) Action S3 Measurement/records of Raw and Treated Water Volume at Seven WTPs

- Construction of flow meter chambers for the first five flow meters in Abbasa WTP is continued.
- C/P should clarify the schedule of the mechanical/electrical installation work for flow meters.

(3) Action S4 Development of SOPs for Model Facilities

- Activity of making of SOP documents for Abbasa WTP is in progress.

(4) Action S5 SOP activities for Water Distribution Control in the Network S5-1 Pilot Project for Distribution Control in Small Areas

- SHAPWASCO shall proceed tender opening of the construction works for five flow meters on 3rd November 2007. It is expected to start actual construction by the end of November 2007.

(5) Action S9 Development of Water Quality Control System

- An internal audit was conducted at Hihya Laboratory to check and assess its laboratory and analytical environment on 4th October.
- Auditing for Abbasa Laboratory was conducted on 9th October.
- Workshop for Process Control has been conducted on 27th October 2007.
- The date for execution of auditing for Zagazig Laboratory is to be announced soon.
- Water Quality Control Programmes for Abbasa and Zagazig have been elaborated and their completion is expected in this week.
- English version (revision-0) of SOP for laboratories has been completed and

3

translation works is proceeding.

(6) Action S10 Well Monitoring

- Well monitoring was started in Faqus Markaz.
- The remaining works of well monitoring for Hihya and Abu Kabier Markaz will start in the next week.
- Data entry for well monitoring is in progress.

3-2. Schedule for the next week

Above activities will be continued in the next week.

4. Others

(1) Open workshop

- The team proposed to have an open workshop in the following manner;
 - Date : 26th (Monday) November 2007
 - Place : Military Club in Zagazig
 - Program :
 - ↪ Presentation of the achievement of UFW and SOP activities which have been made so far.
 - ↪ Open discussions with other water company's staff on the topic which will be set beforehand.
- The draft is attached to this agenda (**Attachment-2**).
- C/P stated that the open workshop should be held separately on the different date for UFW reduction activity and SOP activity because attendants will be engineers and operators related to those activities and the number will be large.
- The team will examine the C/P comments and propose the revised schedule and program by early next week.

(2) Electrical engineer

- The team requested C/P to allocate, urgently, one electrical engineer for SOP HQ team working for preparation and execution of SOP for electrical facilities.
- C/P will nominate one electrical engineer by early next week.

5. Next PTM

The team proposed to have next PTM on 8th November 2007.

(End of MM)

4

Attachment-1

Selection of Pilot Project Area in Hihya Markaz

The following table indicates the results of the minimum night flow survey and numbers of water meters in Hihya Markaz. The MNF ranged from 25 (%) to 44 (%) with an average of 32 (%).

The four areas except Area-4 have a relatively good average pressure around two bars.

| Area | Number of total water meters | Number of non-working water meters | Date of survey for MNF | MNF Ratio (%) | MNF (L/S) | Ave Pressure on MNF (bar) |
|--------|------------------------------|------------------------------------|------------------------|---------------------------|-----------|---------------------------|
| Area-1 | 2,757 | 357 (12.9%) | 4-5 June, 2007 | 44.0 | 19.39 | 2.2 |
| Area-2 | 1,813 | 149 (8.2%) | 5-6 June, 2007 | 33.6 | 3.96 | 2.3 |
| Area-3 | 781 | 34 (2.0%) | 2-3 June, 2007 | 26.0 | 1.86 | 1.5 |
| Area-4 | 552 | 10 (2.0%) | 5-6 June, 2007 | 5.4 (will be excluded) | 0.12 | 2.0 |
| Area-5 | 2,024 | 154 (7.6%) | 29-30 May, 2007 | 25.3 | 3.86 | 2.5 |

Note: Source for the number of water meter connection and non-working meters is based on SHAPWASCO.

Area-2 "South-eastern area of Hihya city" was selected as the pilot project area in Hihya Markaz for the following reasons;

1- The area is very close to the average value in the all candidate areas.

2- The area has the best pressure level (2.3 bar) and signal.

3- The number of water meter is near the required range (1000-1500 connections).

4- The number of non working water meter is not large.

Open Workshop for Presentation and Discussions on Latest Achievements in the Project



- ◆ Date and Time : 26th (Monday) November 2007
- ◆ Place : Military Club in Zagazig
- ◆ Program : As shown below (draft)

| Time | Program | Speaker |
|---------------|--|---|
| 10:00 – 10:30 | Registration (Taking tea and coffee) | |
| 10:30 – 10:40 | Opening speech | Chairman of Holding Company for Water and Wastewater (HCWW) |
| 10:40 – 10:50 | [Part-1] Progress of the Project | JICA Expert Team |
| 10:50 – 11:10 | [Part-2] Latest achievement for UFW reduction activity | UFW Team of SHAPWASCO |
| 11:10 – 11:20 | Discussion | |
| 11:20 – 11:40 | [Part-3] Latest achievement for SOP activity | SOP Team of SHAPWASCO |
| 11:40 – 11:50 | Discussion | |
| 11:50 – 12:10 | Coffee break | |
| 12:10 – 13:10 | [Part-4] Open discussions for UFW and SOP activities The attendants will be divided into 2 groups each for UFW and SOP. (Topic for discussions will be decided and informed to the attendants beforehand) | Engineers and/or staff of SHAPWASCO and other water companies |
| 13:10 – 13:40 | Preparation of the results from the discussion | Group members |
| 13:40 – 14:20 | Presentation of the results (10minutes for each group) | Representative of each group |
| 14:20 – 14:30 | Closing speech | Chairman of SHAPWASCO |
| 14:30 – 15:30 | Lunch | |

6

The Project for Improvement of Management Capacity of
Operation and Maintenance for SHAPWASCO (Phase-2)

Minutes of Meeting for 17th Project Team Meeting for PH-2 MM-PTM2-17 [07.11.08]

| Date | 8 th November (Thursday) 2007 | Signature |
|------------|---|--|
| Time | 9:30~10:30 | |
| Place | SHAPWASCO chairman's room | |
| Attendants | <p>[SHAPWASCO : C/P] Eng. Alae El Din Mohamed : Head of UFW/HQ Team Eng. Abdel Shafi Abdel Aziz : Head of SOP/HQ Team Eng. Ibrahim Shahin : SOP/HQ Team (Electrical) Mr. Mohamed Osama Ahmed : SOP/HQ Team (Water Quality Control) Eng. Gamal Abd El Hameed Morsi : SOP/HQ Team (Well Monitoring) Eng. Wala Mohamed Ali : UFW/HQ Team</p> <p>[JICA Expert Team : The team] Mr. Masahiro Takeuchi : Team Leader Mr. Masatoshi Seno : UFW Reduction Mr. Akihiko Okazaki : Leak Detection Mr. Mohamed Nagi : Facilitator</p> |   |

1. General

(1) Japanese Expert schedule

The team reported that the following Japanese expert arrived in Egypt as scheduled:
 - Mr. Akihiko Okazaki: 6th November 2007

(2) C/P Electrical engineer

C/P appointed Eng. Ibrahim Shahin as the electrical engineer for SOP/HQ team. Mr. Ibrahim started his activity with the team since 3rd November 2007.

(3) Water conservation education activity

- The team requested C/P to expand their activity to other schools and/or residents in the Governorate from now on.
- The team and C/P discussed on the expansion of the activity and agreed to start it in the Markazes of Zagazig, Ibrahimiya, Diarb Nigm and Zagazig City.
- C/P stated that Mr. Ahmed El Fiki was appointed as the person-in-charge for the activity after Ms. Alia took a long leave.
- SHAPWASCO will make a detailed plan and schedule for further activity within one week.

1

2. UFW Reduction Activity (progress of this week and schedule for the next week)

2-1. Progress of This Week

Actions U2, U4, U7, U9 and U10 have been conducted this week. The progress and the issues are summarized as follows:

- (1) **Action U2** Conducting leakage (or MNF) survey for candidate sites
 - The construction of chambers for portable flow meter setting in Area-1 & 2 of Zagazig City West has been completed this week.
- (2) **Action U4** Preparing GIS drawings
 - Updating works for Area-1 and Area-2 of Hihya City have been completed and the draft of GIS network drawings for Area-3, 4 and 5 of Hihya Markaz was delivered to the site office for checking this week. GIS drawings for Area-3, 4 and 5 of Hihya Markaz will be completed by 10th November 2007.
- (3) **Action U7** Surveying installation conditions of water meters
 - The detailed survey of the installation conditions of water meters in the pilot project area (Area-2) of Hihya Markaz started this week.
- (4) **Action U9** Conducting leakage (MNF) survey (before repair works)
 - Water consumption survey during midnight hours in the selected five (5) houses (or connections) in Area-2 of Hihya Markaz started this week (for the purpose of proper evaluation of the obtained MNF survey results).
 - Out of five houses (or connections), the survey was finished for three houses and will be finished in the next week for the remaining houses.
- (5) **Action U10** Making water balance analysis before repair works
 - C/P has started cleaning and repairing of non working water meters in Area-1 of Zagazig East and the replacement will start from the next week.

2-2. Schedule for the Next Week

- Actions of U4, U7, U8, U9 and U10 will be conducted in the next week.

3. SOP Activity (progress of this week and schedule for the next week)

3-1. Progress of This Week

Actions S1, S3, S4, S5, S9 and S10 have been conducted this week. The progress and the issues are summarized as follows:

(1) Action S1 Basic System Drawings

- Eng. Hesham Gamal has completed digitization of P&ID, layout & piping, electric single-line diagrams and cable route drawing (except cable route for Belbis BPS) for model facilities.

2

- Checking of P&ID for Model facilities have completed and checking of layout & piping drawing (except New Faqus WTP) will be completed on 6th November, 2007.
 - The first version of P&ID, layout and piping will be issued by expert team to the model facilities.
 - Eng. Ibrahim Shahin (electrical engineer) for SOP H/Q team will start checking from 7th November 2007 the electrical single-line diagrams and cable route drawings. These documents have been prepared by the expert team for the model facilities with the participation of the model facilities staff. It is expected to complete the check by 17th November 2007.
- (2) **Action S3** Measurement/records of Raw and Treated Water Volume at Seven WTPs
- Construction of flow meter chambers for the first five flow meters in Abbasa WTP is in progress. These chambers are under construction through direct order contract, while tender opening for the construction works for the remaining chambers for other WTPs together with the chambers for Action S5 was conducted on 3rd November 2007. It is expected for C/P to start actual construction by the end of November 2007
 - Schedule of the civil and electrical work for flow meters to be installed in Abbasa WTP was clarified between C/P, expert team, civil works contractor and electrical installation works contractor as follows:
 - Civil and electrical works for the chambers will be completed by the first week of December 2007. The civil and electrical contractors will submit the detailed schedule in the next week.
- (3) **Action S4** Development of SOPs for Model Facilities
- Activity of making SOP documents for Abbasa WTP is in progress.
- (4) **Action S5** SOP activities for Water Distribution Control in the Network S5-1 Pilot Project for Distribution Control in Small Areas
- C/P has conducted the tender opening of the construction works of flow meter chambers on 3rd November 2007 together with the chambers for Action S3 and will execute contract with the contractor in the next week. It is expected for C/P to start actual construction by the end of November 2007.
- (5) **Action S9** Development of Water Quality Control System
- Water Quality Control Programmes for Abbasa and Zagazig have been completed as scheduled.
 - English version (version-0) of SOP for laboratories has been completed and translation works is in progress.
 - C/P stated that the execution of the auditing for Zagazig Laboratory will be finished on 14th November 2007.

3

- (6) **Action S10** Well Monitoring
- Well monitoring in Faqus and Abu Kabier Markaz has been completed.
 - The remaining works of well monitoring for Hihya Markaz will start in the next week.
 - Data entry for well monitoring is in progress.
 - C/P stated that they will report the progress of data entry in percentage and the remained data entry in detail in the next PTM.

3-2. Schedule for the Next Week

Above activities will be continued in the next week.

4. Open Workshop

- The team proposed to have open workshop for UFW reduction activity and SOP activity separately on the different date as follows:

[Open workshop for UFW reduction activity]

- Date and time : 25th (Sunday) November 2007, from 10:30 to 15:30
- Place : Police Club in Zagazig
- Program :
 - ◆ Presentation of the latest achievement of UFW reduction activity
 - ◆ Open discussions with other water company's staff on the specified topic

[Open workshop for SOP activity]

- Date and time : 26th (Monday) November 2007, from 10:30 to 15:30
- Place : Police Club in Zagazig
- Program :
 - ◆ Presentation of the latest achievement of SOP activity
 - ◆ Open discussions with other water company's staff on the specified topic

The draft is attached to this agenda (**Attachment-1**).

5. Next PTM

The team proposed to have next PTM on 15th November 2007.

(End of agenda)

4

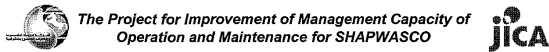

Open Workshop for Presentation and Discussions on Latest Achievements for UFW Reduction Activity in the Project

Attachment-1

- ◆ Date and Time : 25th (Sunday) November 2007, from 10:30 to 15:30
- ◆ Place : Police Club in Zagazig
- ◆ Program : As shown below (draft)

| Time | Program | Speaker |
|---------------|--|---|
| 10:30 – 11:00 | Registration (Taking tea and coffee) | |
| 11:00 – 11:10 | Opening speech for UFW reduction activity | Chairman of SHAPWASCO |
| 11:10 – 11:40 | [Part-1] Latest achievements of UFW reduction activity (Including explanation of the applied leakage survey and detection methods) | UFW/HQ Team of SHAPWASCO |
| 11:40 – 12:00 | Discussion | |
| 12:00 – 12:30 | [Part-2] Results of Pilot Project in Zagazig City and Hihya Markaz | UFW Team of Zagazig City and Hihya Markaz of SHAPWASCO |
| 12:30 – 12:50 | Discussion | |
| 12:50 – 13:50 | [Part-3] Group discussion on the specified topic (Divided into 2 groups) | Engineers and/or staff of SHAPWASCO and other water companies |
| 13:50 – 14:20 | Presentation of the results (15 minutes for each group) | |
| 14:20 – 14:30 | Closing speech | Chairman of SHAPWASCO |
| 14:30 – 15:30 | Lunch | |

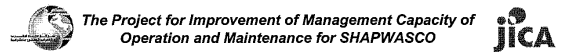



Open Workshop for Presentation and Discussions on Latest Achievements for SOP Activity in the Project

- ◆ Date and Time : 26th (Monday) November 2007, from 10:30 to 15:30
- ◆ Place : Police Club in Zagazig
- ◆ Program : As shown below (draft)

| Time | Program | Speaker |
|---------------|--|---|
| 10:30 – 11:00 | Registration (Taking tea and coffee) | |
| 11:00 – 11:10 | Opening speech for SOP activity | Chairman of SHAPWASCO |
| 11:10 – 11:40 | [Part-1] Latest achievements of SOP activity for Mechanical/Electrical and Well Monitoring | SOP/HQ Team of SHAPWASCO |
| 11:40 – 12:00 | Discussion | |
| 12:00 – 12:30 | [Part-2] Latest achievements of SOP activity for Water Quality Control | SOP/HQ Team of SHAPWASCO |
| 12:30 – 12:50 | Discussion | |
| 12:50 – 13:50 | [Part-3] Group discussion on the specified topic (Divided into 2 groups) | Engineers and/or staff of SHAPWASCO and other water companies |
| 13:50 – 14:20 | Presentation of the results (15 minutes for each group) | |
| 14:20 – 14:30 | Closing speech | Chairman of SHAPWASCO |
| 14:30 – 15:30 | Lunch | |

The Project for Improvement of Management Capacity of
Operation and Maintenance for SHAPWASCO (Phase-2)

Minutes of Meeting for 18th Project Team Meeting for PH-2
MM-PTM2-18 [07.11.17]

| | | |
|------------|--|---|
| Date | 17 th November (Saturday) 2007 | Signature |
| Time | 15:00~16:00 | |
| Place | SHAPWASCO chairman's room | |
| Attendants | [SHAPWASCO : C/P] Dr. Salah Bayoumi : Chairman/Project Manager Eng. Alae El Din Mohamed : Head of UFW/HQ Team Eng. Abdel Shafi Abdel Aziz : Head of SOP/HQ Team Eng. Ibrahim Shahin : SOP/HQ Team (Electrical) Mr. Mohamed Osama Ahmed : SOP/HQ Team (Water Quality Control) Eng. Gamal Abd El Hameed Morsi : SOP/HQ Team (Well Monitoring) |  |
| | [JICA Expert Team : The team] Mr. Masshiro Takeuchi : Team Leader Mr. Masatoshi Seno : UFW Reduction Mr. Noboru Saeki : SOP Activity Mr. Akihiko Okazaki : Leak Detection Mr. Mohamed Nagi : Facilitator Dr. Mohamed Sobhy : Senior Engineer for UFW Mr. Mahmoud Khalaf : Senior Engineer (M) for SOP |  |

1. General

- (1) Japanese Expert schedule
 - The team reported that the following Japanese expert arrived in Egypt as scheduled:
 - Mr. Noboru Saeki : 16th November 2007
- (2) Water conservation education activity
 - > C/P prepared the detailed schedule as shown in **Attachment -1**.
 - > The team and C/P visited El Sedes junior high school for boys and El Saïda Khadiga junior high school for girls in Ibrahimiyah Markaz on 14th November 2007 as scheduled and a site tour by the students to Hihya WTP will be made on 19th November.
2. UFW reduction activity (progress of the last week from 10th to 15th November and schedule for this week from 17th to 22nd November)

2-1. Progress

Actions U4, U7, U8, U9 and U10 were conducted last week. The progress and the issues are

1

summarized as follows:

Common Activity

- (1) **Action U4** Preparing GIS drawings (for network)
 - > Updating works for Hihya city (Area-1, 2, 3, 4 and 5) have been completed and the draft of GIS network drawings for Zagazig City West (Area-1, 2, 3, 4 and 5) was finished last week and will be delivered to the site office for checking this week.

Pilot Project -1 : Zagazig City-East (Area-1)

- (1) **Action U8** Measuring metering error of water meter
 - > Measuring metering error of water meter was started last week and will be completed this week.
- (2) **Action U10** Making water balance analysis before repair works
 - > SHAPWASCO finished cleaning and repairing of non working water meters and about 70 water meters were required to be replaced and the replacement of water meters started and finished last week.
 - > 7 days continuous MNF survey and water meter reading started on 14th November 2007.

Pilot Project -2 : Hihya Markaz (Area-2)

- (1) **Action U7** Surveying installation conditions of water meters
 - > The detailed survey of the installation conditions of water meters was completed last week.
- (2) **Action U9** Conducting leakage (MNF) survey (before repair works)
 - > Water consumption survey during midnight hours in the selected five (5) houses is continued this week (for the purpose of proper evaluation of the obtained MNF survey results).

2-2. Schedule for this week

- Actions of U4, U7, U8, U9 and U10 will be conducted this week.

3. SOP activity (progress of the last week from 10th to 15th November and schedule for this week from 17th to 22nd November)

3-1. Progress

Actions S1, S3, S4, S5, S9 and S10 were conducted last week. The progress and the issues are summarized as follows:

(1) Action S1 Basic System Drawings

- > Eng. Hesham Gamal has finished digitization of P&ID, layout & piping, electric

2

single-line diagrams and cable route drawing for model facilities.

- > Checking of P&ID for Model facilities and checking of layout & piping drawing have been completed.
 - > The first version of P&ID, layout and piping will be issued by the team to the model facilities.
 - > Eng. Ibrahim Shahin has finished checking the electrical single-line diagrams and cable route drawings of the model facilities except Aslougi well station. It is expected to complete Aslougi on 19th November, 2007.
- (2) **Action S3** Measurement/records of Raw and Treated Water Volume at Seven WTPs
 - > Construction of flow meter chambers for the first five flow meters in Abbasa WTP is continued.
 - > C/P has prepared the attached schedule as in **Attachment-2** for the completion of civil works and electrical works. It is expected for the contractor of C/P to complete the whole works by 14th December, 2007.
 - > Tender opening for the construction works of the remaining chambers for sixteen flow meters in other WTP's together with the chambers for the five flow meters in Action S5 was conducted on 3rd November 2007. It is expected for the contractor of C/P to start actual construction by the end of November 2007.
 - > C/P has the intention to shift the installation of two flow meters (one at treated water pipe in Old Zagazig WTP and the other at the treated water pipe in Old Faqus WTP) to new locations at the two outlet pipes in Bilbais BPS because SHAPWASCO has a plan to rehabilitate Old Zagazig WTP and Old Faqus WTP including installation of the above two flow meters.
 - > Expert Team requested C/P to submit construction schedule for the rehabilitation and further details regarding SHAPWASCO plans and intention.
 - (3) **Action S4** Development of SOPs for Model Facilities
 - > Activity of making SOP documents for Abbasa WTP is in progress.
 - (4) **Action S5** SOP activities for Water Distribution Control in the Network
 - S5-1 Pilot Project for Distribution Control in Small Areas
 - C/P has conducted the tender opening of the construction works for five flow meters on 3rd November 2007. It is expected to start actual construction by the end of November 2007.
 - (5) **Action S9** Development of Water Quality Control System
 - > The auditing for Zagazig Laboratory has been completed on 14th November, 2007.
 - > English version (version-0) of SOP for laboratories has been completed and translation works is proceeding. It is expected to complete this work by 14th December, 2007.

3

- (6) **Action S10** Well Monitoring
 - > Well monitoring for Hihya Markaz will be completed on 20th November 2007.
 - > 50% of the data entry for well monitoring has been completed. It is expected to complete the works by the middle of December 2007.
- 3-2. Schedule for this week**
Above activities will be continued this week.
4. **Open Workshop**
The preparation work for open workshop to be held on 25th November for UFW and 26th November for SOP has been done last week and will be continued this week.
 5. **Next PTM**
C/P and the team agreed to have next PTM on 24th November 2007.

(End of MM)

4

3-1. Progress

Actions S1, S2, S3, S4, S5, S9 and S10 were conducted last week. The progress and the issues are summarized as follows:

(1) Action S1 Basic System Drawings

- > The first version of P&ID, layout and piping will be issued by the team to the model facilities on 27th November, 2007 and expected to be completed on 29th November, 2007.
- > Eng. Ibrahim Shahin has finished checking the electrical single-line diagrams and cable route drawings for the model facilities.
- C/P proposed to hire survey company to prepare detailed survey drawings for general layout of the model facilities. These drawings will be used to show the exact locations for piping and cables.

(2) Action S2 Preparation of unified forms for O&M records and reports

- > The PCs for SOP activities were distributed to the model facilities and unified forms of O&M for prior items will be installed to the PCs for trial recording.
- > Expert Team requested C/P to prepare the plans and budget for the necessary measurement equipment for chemical consumption, energy consumption...etc.
- C/P will complete the survey of the required measurement equipment for the model facilities on 11th December 2007. Survey for cost estimation and explanation to the top management for approval and budget allocation will proceed accordingly.

(3) Action S3 Measurement/records of Raw and Treated Water Volume at Seven WTPs

- > Construction of flow meters chambers for the first five flow meters in Abbasa is continued. Manufacturing of flow meter indicator panels have been completed by electro mechanical contractor. It is expected for the contractor of SHAPWASCO to complete the whole works by 14th December, 2007
- > Tender opening for the construction works of the remaining chambers for sixteen flow meters in other WTP's together with the chambers for the five flow meters in Action S5 was conducted on 3rd November 2007. It is expected for the contractor of SHAPWASCO to start actual construction by the end of November 2007.
- > Expert team requested SHAPWASCO to clarify the progress of sites handing over to the contractor to start construction.
- > C/P has the intention to shift the installation of two flow meters (one at treated water pipe in Old Zagazig WTP and the other at the treated water pipe in Old Faqus WTP) to

3

new locations at the two outlet pipes in Bilbais BPS because SHAPWASCO has a plan to rehabilitate Old Zagazig WTP and Old Faqus WTP including installation of the above two flow meters.

- > Expert Team inquired C/P to submit construction schedule for the rehabilitation and further details regarding SHAPWASCO plans and intention

(4) Action S4 Development of SOPs for Model Facilities

- > Activity of making SOP documents for Abbasa WTP is in progress.
- > Expert team requested SHAPWASCO to clarify the progress of purchasing the required testing equipment for the electrical SOP activity (Attachment S1).

(5) Action S5 SOP activities for Water Distribution Control in the Network S5-1 Pilot Project for Distribution Control in Small Areas

- C/P has conducted the tender opening of the construction works for five flow meters on 3rd November 2007. It is expected to start actual construction by the end of November 2007.

- > Expert team requested SHAPWASCO to clarify the progress of sites handing over to the contractor to start construction.

(6) Action S9 Development of Water Quality Control System

- > English version (version-0) of SOP for laboratories has been completed and translation works is proceeding. It is expected to complete this work by 14th December, 2007.

(7) Action S10 Well Monitoring

- > Well monitoring data collection has been completed.
- > 75% of the data entry for well monitoring has been completed. It is expected to complete the works by the middle of December 2007.

3-2. Schedule for this week

Above activities will be continued this week.

4. Additional Three Pilot Areas

- > Based on the Minutes of Meeting (III. Discussions -2. UFW Pilot Project Area), the C/P requested JICA expert team to extend the coverage of UFW for other three more Markazes.
- > SHAPWASCO HQ considers applying the above request in Abu Hamad, Bilbais and Menia Al qamah Markazes.
 - JICA expert team will examine and transfer this request to JICA HQ.

4

MM-PTM2-20 (1/7)

5. Next PTM

The team proposed to have next PTM on 11th December 2007.

(End of agenda)

Minutes of Meeting for 20th Project Team Meeting for PH-2

MM-PTM2-20 [08.2.14]

| Date | 14 th February (Thursday) 2008 | Signature |
|------------|---|-----------|
| Time | 10:00 ~ 12:00 | |
| Place | SHAPWASCO chairman's room | |
| Attendants | <p>[SHAPWASCO : C/P]</p> <p>Dr. Salah Bayoumi : Chairman/Project Manager Eng. Alae El Din Mohamed : Head of UFW/HQ Team Eng. Abdel Shafi Abdel Aziz : Head of SOP/HQ Team Eng. Ibrahim Shahin : SOP/HQ Team (Electrical) Mr. Mohamed Osama Ahmed : SOP/HQ Team (Water Quality Control) Eng. Gamal Abd El Hameed Morsi : SOP/HQ Team (Well Monitoring)</p> <p>[JICA Expert Team : The team]</p> <p>Mr. Masahiro Takeuchi : Team Leader Mr. Masatoshi Seno : UFW Reduction Mr. Keizo Kimura : SOP Activity Dr. Ashraf Ahamed : Electrical Equipment Mr. Nobuyuki Iijima : Hydrogeology Mr. Mohamed Nagi : Facilitator Mr. Mahmoud Khalaf : Senior Engineer (M) for SOP</p> | |

1. General

(1) Japanese Experts' Schedule

The team reported that the following Japanese experts arrived in Egypt and started their activity on 9th February 2008:

- Mr. Masahiro Takeuchi: Chief Advisor
- Mr. Masatoshi Seno: UFW Reduction
- Mr. Nobuyuki Iijima: Hydrogeology

(2) Schedule of JICA Monitoring Mission

- > The team informed C/P that JICA headquarters will dispatch a mission for monitoring the project. The schedule for the mission is not finalized yet. According to the information of JICA/Tokyo, the mission is expected to start their monitoring work from 27th of February and finish on 6th of March 2008.

(3) Public Awareness Campaign

- > It is expected the necessary security permission be issued by the beginning of the next week.
- > New schedule for school visits will be prepared as soon as receiving the security permission.

5

1

(4) Inspection Tour by JICA Egypt Office

- The team informed C/P that JICA Egypt Office will make an inspection tour on 20th February 2008.

2. UFW reduction activity (progress of the previous weeks from 5th of December 2007 to 13th February 2008 and schedule for next week from 16th to 21st February 2008)**2-1. Progress**

Action U4 as the common activity, Actions U6 to U12 for Pilot Project-2 (Hihya Markaz) and Actions U7, U10 and U11 for Pilot Project-3 (Zagazig City-West), have been conducted by the last week. The progress and the issues are summarized as follows:

Common Activity(1) **Action U4** Preparing GIS drawings (for network)

- Preparation of the following GIS network drawings have been completed by the end of January 2008.
 - 1) Zagazig East: 5 candidate areas for pilot project area
 - 2) Zagazig West: 5 candidate areas for pilot project area
 - 3) Hihya Markaz: 5 candidate areas for pilot project area
 - 4) Zagazig Markaz: Area-1 (Kafr Hamam) of pilot project area
- The draft of GIS network drawings for Area-1 (Diarb Nigm City) of pilot project area in Diarb Nigm Markaz will be finished this week and Area-1 (Ibrahimiya City) of pilot project area in Ibrahimiya Markaz will be started next week.

Pilot Project -1: Zagazig City-East (Area-1)

- All activities have been finished by the end of January 2008 and final water balance analysis will be done in February 2008.
- C/P will make further survey to confirm the operation mode of the public entities such as bakeries, hospital, etc at night time.

All locations of leakage points repaired in the past several years shall be input in GIS drawing in order to make the future plans for pipeline rehabilitation.

Pilot Project -2: Hihya Markaz (Area-2)(1) **Action U6** Making field survey of distribution network

- The detailed field survey of the conditions of pipelines and valves has been conducted according to GIS drawings.

(2) **Action U7**: Surveying installation & status conditions of water meters and conducting

2

meter readings

- The survey of the installation conditions of water meters has been completed.
 - 1) 100 non-working meters were repaired until last week.
 - 2) 600 water meters are under checking and final number of non-working meter to be replaced will be fixed this week.
- (3) **Action U8**: Measuring metering error for working meters and water wastage in the house
 - Measuring metering error of 20 water meters has been finished. The result is that the existing meters' reading was 21% more than the reading by the calibrated meter in average. C/P will make a further survey for the causes.
- (4) **Action U9**: Conducting leakage (MNF) survey (before repair works)
 - Water consumption survey during midnight hours in the selected houses has been finished and analysis will be done next week.
- (5) **Action U10**: Making water balance analysis before repair works
 - Seven (7)-day continuous MNF survey and water meter reading have been finished. Water balance analysis will be done next week.
- (6) **Action U11**: Conducting leakage detection survey
 - Leakage detection survey has been finished and total 19 places of leakage have been found. Almost all the leakages were visible on the surface of non-asphalt road. (refer to the attached sketch: **Attachment-1**)
- (7) **Action U12**: Repairing leaking parts
 - Leakage parts have been repaired by SHAPWASCO.

Pilot Project -3: Zagazig City-West (Area-3)(1) **Action U6**: Making field survey of distribution network

- The detailed field survey of the conditions of pipelines and valves has been conducted according to GIS drawings.

(2) **Action U7**: Surveying installation conditions of water meters and conducting meter readings

- The survey of the installation and status conditions of water meters has been completed and final number of non-working meter to be replaced will be fixed this week.

(3) **Action U11**: Conducting leakage detection survey

- Leakage detection survey was conducted last week and continued this week. Six (6) doubtful places for leakage were found.

3

Three (3) places of illegal connection were found during survey and the detail information of these connections is as follows: In spite of SHAPWASCO's request to pay for water charge to the customers in several times, the customers did not pay it. Therefore, SHAPWASCO dismantled water meter to disconnect the line and then customer connected pipe illegally.

2-2. Schedule for next week

- Actions of U4, U7, U10 and U11 will be conducted this week.

3. SOP activity (progress of the previous weeks from 5th of December 2007 to 13th February 2008 and schedule for next week from 16th to 21st February 2008)**3-1. Progress**

Actions S1, S2, S3, S4, S5, S6, S9 and S10 have been conducted by the last week. The progress and the issues are summarized as follows:

(1) **Action S1**: Preparing Basic System Drawings

- The first version of P&ID, layout and piping has been distributed by the team to the model facilities.
- Arabic Translation for P&ID, layout and piping has been requested by the operators of the facilities.
 - It is expected that the translation be completed by the end of February 2008.
 - C/P proposed to hire Survey Company to prepare detailed survey drawings for general layout of the model facilities. These drawings will be used to show the exact locations for piping and cables.
 - The team requested SHAPWASCO to clarify the progress of hiring the survey company.
 - C/P will confirm the situation of preparing the detailed survey drawings with the consultant who is preparing the Water & Sewage Master Plan for SHAPWASCO to avoid work duplication.

(2) **Action S2**: Preparing unified forms of O&M records and reports

- The PCs for SOP activities were distributed to the model facilities and electronic data of unified forms for prioritized O&M items have been filed in the PCs at Abbasa and Zagazig WTPs for trial recording.
 - The team requested SHAPWASCO to precede computer training program for the plant manager, chemists, etc. to assist them in usage of the distributed computers for recording.
- The team requested C/P to prepare the plans and budget for the necessary measurement equipment for chemical consumption, energy consumption, etc.

4

- SHAPWASCO explained that they started to collect offers for the requested equipment and will apply direct order purchasing to avoid long period for tendering procedures. Detailed schedule for the equipment purchasing will be submitted within the next two weeks.

(3) **Action S3**: Measuring Intake/Production Water Volume at Seven (7) WTPs

- The civil works for four (4) new flow meter chambers for five (5) flow meters in Abbasa WTP to measure the treated water have been completed.
- Repair work for the existing two (2) valve chambers in Abbasa WTP to measure raw water is expected to be completed by 18th February 2008.
- Manufacturing of flow meter indicator panels for the remaining flow meters in Abbasa have been completed by electro-mechanical contractor.
- Two (2) flow meters in valve chambers No.1 & No.2 for treated water have been installed at Zagazig and Faqus WTPs and recording started from 15th December 2007.
- Installation works for the remaining flow meters to measure the treated water will start by the next week.
- Construction works (civil works) of the remaining chambers for sixteen (16) flow meters in other WTPs together with the chambers for five (5) flow meters in Action S5 is proceeding. Detailed situation for the construction works of valve chamber for Action S5 will be clarified below in Action S5.
- Civil works for two (2) flow meter chambers were completed: one for New Faqus WTP and the other in Hihya Markaz (Action S5).
- C/P decided to shift the installation of two (2) flow meters (one at treated water pipe in Old Zagazig WTP and the other at the treated water pipe in Old Faqus WTP) to new locations at two (2) outlet asbestos cement pipes in Bilbais BPS because SHAPWASCO has a plan to rehabilitate Old Zagazig WTP and Old Faqus WTP including installation of the above two (2) flow meters.
- Construction works for flow meter valve chambers of raw water at Old Zagazig and Old Faqus WTPs will be postponed until completion of the rehabilitation works of the above said plants. It is expected that the rehabilitation works be completed by June 2008 according to the submitted schedules by SHAPWASCO.

(4) **Action S4**: Developing SOPs for Model Facilities

- Major part of SOP documents for WTP has been completed and distributed to Abbasa and Zagazig WTPs.
- Major part of SOP documents for Fe/Mn plants has been completed and will be distributed to model facilities by 16th February, 2008.

5

- Seven (7) equipments of the required testing equipment for the electrical SOP activity have been delivered to SHAPWASCO stores. Purchasing of the remaining four (4) equipments (dial meter, sound level meter, LCI and vibration meter) are proceeding and expected to be completed by next week except vibration meter that will take longer time because it is not available in the local market.
 - The team will hold OJT for usage of this equipment by 23rd February 2008 using the available vibration meter in Hihya WTP.
- (5) **Action S5:** Examining Water Distribution Control Practice in the Network
S5-1: Pilot Project for Distribution Control in Small Areas
- Civil works for one (1) new flow meter chamber have been completed and C/P is facing problems for the construction of the remaining three (3) new chambers due to road cut permission in the new constructed roads at two (2) sites and main electric and telephone cables at one (1) site.
 - SHAPWASCO is taking the necessary actions to overcome this situation and will inform the team of the final situation by 19th February 2008 to take the necessary actions regarding changing the location of the flow meter chamber.
- (6) **Action S6:** Applying SOPs in O&M
- Applying SOP in O&M started in Zagazig WTP on 3rd February 2008.
 - Applying SOP in O&M started in Abbasa WTP on 9th February 2008.
 - Internal workshop for applying SOP was held at Abbasa WTP on 9th February 2008.
- (7) **Action S9:** Developing Water Quality Control Program
- Arabic translation for revision-0 has been completed.
 - The team requested SHAPWASCO to distribute the translated documents to the laboratories.
 - The team requested SHAPWASCO to prepare SOP for laboratories such as jar test, sampling procedures, break point test, etc.
- (8) **Action S10:** Developing Well Inventory Forms and Monitoring Well Stations
- Data entry for well monitoring has been completed.
 - Location map to show the existing working well stations in Sharkia has been prepared using the existing GIS maps.
 - Contour maps to show TDS, Fe and Mn are under preparation.
 - Contour maps for static water level and ground water elevation are under preparation.

6

3-2. Schedule for next week

Above activities will be continued during the next week.

4. JCC and Open Seminar**4-1. JCC**

The team proposed to have Joint Coordinating Committee (JCC) on 4th March 2008 for getting approval of Project Design Matrix-2 (PDM2), the 2nd revision of PDM0 which was confirmed between the Egyptian side and the Japanese side in the Minutes of Meeting signed on 13th June 2006. Main items for the revision are as follows:

- Setting targets of UFW and leakage ratio for the pilot project areas
- Additional three (3) pilot project areas for UFW reduction activity
- Change of model facility for SOP activity (electrical)

The draft of PDM2 and PO2 will be submitted to C/P next week.

4-2. Open Seminar

The team proposed to have an open seminar on the same day of JCC (4th March 2008). The program (draft) of the seminar is shown in **Attachment-2**.

5. Next PTM

The team proposed to have next PTM on 21st February 2008.

(End of agenda)

7

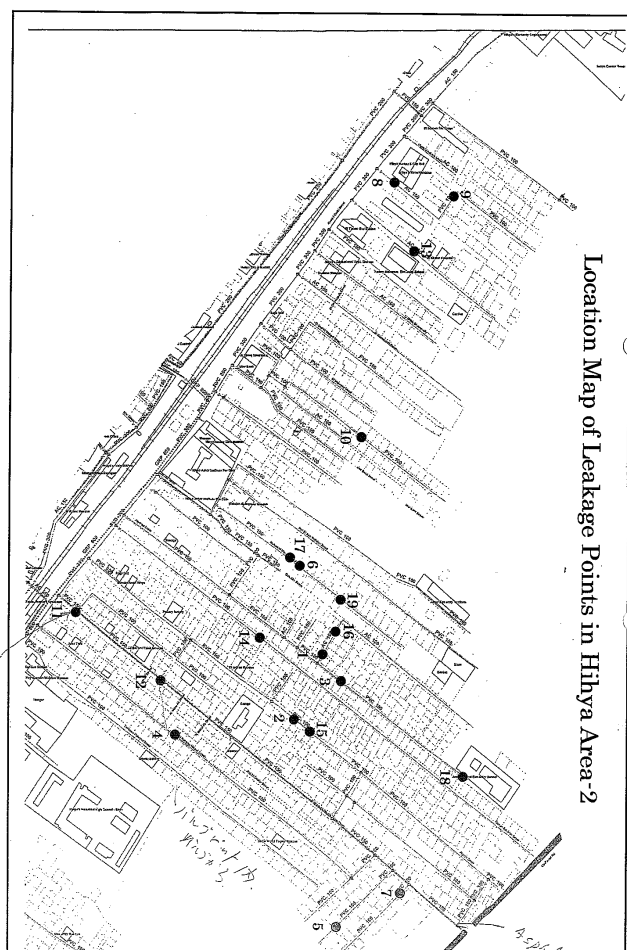

Attachment-2

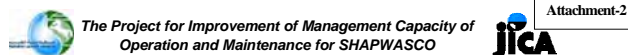

Program of JCC & Seminar
(4th of March 2008 at Grand Hyatt Hotel in Cairo)

DRAFT

| Time | Program | Speaker |
|---|--|---|
| [JCC : Joint Coordinating Committee] | | |
| 9:00 – 9:10 | Opening speech | Chairman of HCWW |
| 9:10 – 9:30 | Progress of the Project and explanation of PDM2 and PO2 PDM : Project Design Matrix PO : Plan of Operation | Mr. Masahiro Takeuchi Chief Advisor of JICA Expert Team |
| 9:30 – 9:50 | Discussion on PDM2 and PO2 | |
| 9:50 – 10:00 | Signing on M/M | |
| 10:00 – 10:30 | Coffee break Registration of attendants in the seminar | |
| [Seminar] | | |
| 10:30 – 10:50 | Opening speech | Chairman of Holding Company for Water and Wastewater (HCWW) |
| 10:50 – 11:00 | [Part-1] Brief of the Project | JICA Expert Team |
| 11:00 – 11:50 | [Part-2] Second stage achievement for UFW reduction activity | Project Manager and UFW Team of SHAPWASCO |
| 11:50 – 12:10 | Q & A | |
| 12:10 – 12:40 | Coffee break | |
| 12:40 – 13:40 | [Part-3] Second stage achievement for SOP activity | Project Manager and SOP Team of SHAPWASCO |
| 13:40 – 14:20 | Q & A and General Discussion | |
| 14:20 – 14:30 | Closing speech | Chairman of SHAPWASCO |
| 14:30 – 15:30 | Lunch | |