

Material informativo

1. Membros das Missões

2. Cronograma de Estudo

3. Pessoas Relacionadas

4. Minuta(M/D)

5. Outros

Número de Escolas Primárias e Graduados da área alvo

Relatório do Estudo de Solos

Mapa Topográfico efectuados por empresa contractada: Matendene

1. Membros das Missões

1-1 Missão do Desenho Esboço (2 de fevereiro~5 de março de 2009)

Líder	Masami Shukunobe	Representante Residente, JICA-Moçambique
Planeamento	Hitoshi Ara	Oficial Senior, Sec.2 Desenv.Urbano e Reg., Dep. de Desen.Econ. e de Infra-estruturas, JICA
Procurador p/ Supervisão e Planeamento	Shoji Hasegawa	Representante do Director Geral, Dep.1 de Administração, JICS
Director/Planeamento de Instalações e Educação	Akihiko Takeuchi	Matsuda Consultants International Co., Ltd.
Plano Arquitetónico 1	Kenji Kawazoe	Matsuda Consultants International Co., Ltd.
Plano de Fornec. e Obras/ Plano de Ope./ Custos	Mitsuhiro Shimada	Matsuda Consultants International Co., Ltd.
Estudo Sócio-ambiental/ Plano de Equipamentos	Akira Maekawa	INTEM Consulting, Inc.
Plano Arquitetónico 2	Tatsuji Tsuchiya	Matsuda Consultants International Co., Ltd.
Intérprete	Sanae Tanabe	Translation Center Pioneer

1-2 Missão do de Explicação do Desenho Esboço (3 de junho~17 de junho de 2009)

Líder	Tetsu Umenaga	Conselheiro,Dep. de Desen.Econ. e de Infra-estruturas, JICA
Director/Planeamento de Instalações e Educação	Akihiko Takeuchi	Matsuda Consultants International Co., Ltd.
Plano Arquitetónico	Kenji Kawazoe	Matsuda Consultants International Co., Ltd.
Intérprete	Sanae Tanabe	Translation Center Pioneer

2.Cronograma de Estudo

2-1Missão do Desenho Esboço

	Membros do Governo			Membros da empresa de consultoria					
	Líder	Planeamento	Aquisição	A. Director (PM)	B. Plano Arquitectónico	C. Construção, Aquisição e Custos	D.Impacto Ambiental, Equipamentos	E.Plano Arquitectónico 2	F. Intérprete
	Masami Shukunobe	Hitoshi Ara	Shoji Hasegawa	Akihiko Takeuchi	Kenji Kawazoe	Mitsuhiro Shimada	Akira Maekawa	Tatsuji Tsuchiya	Sanae Tanabe
1	Fev/2	s		Tóquio-Hong Kong Hong Kong-Johannesburg					←PM
2	Fev/3	t		Johannesburg-Maputo					←PM
3	Fev/4	q		Reunião-JICA					←PM
4	Fev/5	q		Reunião-MEC.DIPLAC, CEE					←PM
5	Fev/6	s		Reunião-MEC.DIPLAC					←PM
6	Fev/7	s		Reunião-CEE					←PM
7	Fev/8	d		Reunião-MEC.DIPLAC					←PM
8	Fev/9	s		Visita de cortesia-DPEC.Maputo					←PM
9	Fev/10	t		Estudo-ESG Quisse Movota					←PM
10	Fev/11	q		Tóquio-Hong Kong H.K-Johannesburg	Estudo-terreno da cid.Maputo	Tóquio-Hong Kong H.K-Johannesburg		Tóquio-Hong Kong H.K-Johannesburg	←PM
11	Fev/12	q		Chegada à Maputo	Reunião interna	Chegada à Maputo		Chegada à Maputo	
12	Fev/13	s		Reunião-JICA-CEE	Reunião-CEE			←B.C	←PM
13	Fev/14	s		MEC.DAF					
14	Fev/15	d		CEE	DPEC cid.Maputo				
15	Fev/16	s		WB.BAD	DPEC prov.Maputo	Visita-consultores	•Saída de Tóquio	←C	←PM
16	Fev/17	t		Visita-consultores	Estudo-terreno de Khongolote			←B	
17	Fev/18	q		Visita-advogado	Estudo-terreno de Cobe	←JICS	•Chegada à Maputo	←B	←PM
18	Fev/19	q		Reunião-CEE	Estudo-ESG Influe		Reunião-DIPLAC		←PM
19	Fev/20	s		Tóquio-Hong Kong	Reunião-DIPLAC	Estudo-Empreiteiros	Reunião-CEE	←PM	←PM
20	Fev/21	s		Chegada à Maputo	Estudo-ESG da cid.Maputo				←PM
21	Fev/22	d		Visita-KfW/consultores	Reunião-JICA	Estudo-terreno de Manjakaze, Gaza	←B	←B	
22	Fev/23	s		deslocação-Maputo-Xai-xai	Estudo-terreno de Chissano e Manjakaze, Gaza	Estudo-terreno de Chissano	←B	←B	←PM
23	Fev/24	t		Estudo-ESG Manjakaze e ESG Xai-Xai	deslocação-Xai-xai-Maputo				
24	Fev/25	q		Reunião-DIPLAC	•Estudo-ESG do bairro 5 de Maputo	•Estudo- estimativa de custos	←PM	←C	←PM
25	Fev/26	q		Reunião-DIPLAC	Preparação da minuta	Maputo→Cuamba		←C	←PM
26	Fev/27	s		Reunião-DIPLAC	Estudo-ESG de Matola		•Estudo-MICOA	←C	←PM
27	Fev/28	s		Assinatura da minuta	Relato-Embaixada JICA		•Estudo-questões ambientais	←C	←PM
28	Mar/1	d		Maputo-Johannesburg	MEC.DINEG		←PM	←C	←PM
29	Mar/2	s		Johannesburg-Hong Kong	DIPLAC(estatística)		MEC. DINEG	←C	←PM
30	Mar/3	t		Hong Kong-Tóquio	Estudo-medição do terreno		•Estudo-fornecedores de equipamentos	←C	←PM
31	Mar/4	q			•organização dos relatórios	Cuamba→Maputo	•organização dos relatórios		
32	Mar/5	q			MEC.DRH		•Estudo-construções	←C	←PM
33	Mar/6	q			•DIPLAC				←PM
34	Mar/7	t			Estudo-ESG da cid.Maputo				
35	Mar/8	q			DIPLAC				←PM
36	Mar/9	s			ESG da cid. Matola	Reunião-CEE		←C	←PM
37	Mar/10	t			Estudo-DPEC Maputo				DIPLAC
38	Mar/11	q			•Reunião CEE	Reunião-CEE	•Visita-consultores	←C	←PM
39	Mar/12	s			visita-KfW				
40	Mar/13	s			visita-AfDB		•Reunião-CEE	←C	←PM
41	Mar/14	s			•Reunião-CEE				
42	Mar/15	s			•organização dos relatórios		•Estudo-custos	←C	←PM
43	Mar/16	d			•organização dos relatórios				←PM
44	Mar/17	s			CEE				
45	Mar/18	s			DIPLAC				
46	Mar/19	t			•Relato-JICA				←PM
47	Mar/20	t			•Relato-Embaixada				←PM
48	Mar/21	q			Maputo-Johannesburg				
49	Mar/22	q			Johannesburg-Hong Kong				
50	Mar/23	q			Hong Kong-Tóquio				

2-2 Missão de Explicação do Desenho Esboço

			Membro do Governo	Membros da empresa de consultoria		
			Líder	Director (PM)	Plano Arquitetónico	Intérprete
			Tetsu Umenaga	Akihiko Takeuchi	Kenji Kawazoe	Sanae Tanabe
1	Jun/3	q		Tóquio-Hong Kong Hong Kong-Johannesburg		
2	Jun/4	q		Johannesburg-Maputo Reunião-DIPLAC		
3	Jun/5	s		Reuniões-JICA, MEC, CEE	Visita-Consultores locais	←PM
4	Jun/6	s		•Organização dos relatórios	•Organização dos relatórios	
5	Jun/7	d	Tóquio-Hong Kong Hong Kong-Johannesburg			
6	Jun/8	s	Hong Kong-Johannesburg	Reuniões-DIPLAC JICA	Visita-Consultores locais	←PM
7	Jun/9	t	Reunião-DIPLAC			
8	Jun/10	q	Estudo-local /ESG da cid. Maputo /ESG de Matola, terreno de Cobe e Congolote			
9	Jun/11	q	Assinatura da minuta com o MEC Relato-JICAJ	•Organização dos relatórios	←PM	
10	Jun/12	s	Maputo-Johannesburg Johannesburg→Singapura	Estudos-DIPLAC, MICOA, CEE	Distribuição do documento de concurso	←PM
11	Jun/13	s	Singapura→Tóquio	Visita-ESG em construção em Gaza /ESG Macia, Escola Especializada		←PM
12	Jun/14	d				
13	Jun/15	s			Distribuição do documento de concurso Relato-Embaixada, JICA	
14	Jun/16	t		Maputo-Johannesburg Johannesburg-Hong Kong		
15	Jun/17	q		Hong Kong-Tóquio		

3. Pessoas Relacionadas

Instituições Moçambicanas

Ministério da Educação e Cultura

Sra. Maria Albelina Bila

MEC

Secretária Permanente

Dir. de Planeamento e Cooperação

Sr.Manuel A.Magalhães Rego

Sr.Cremildo Ricardo Binana

Sra.Zaida Baule

Sr. Antonio José Matlombe

Sr.Ilídio Buduia

Sr.Alberto Siteo

MEC DIPLAC

Director, DIPLAC

Director Adjunto, DIPLAC

Técnica

Técnico

Chefe, Departamento de Estatística

Técnico, Investimento

Construção e Equip.Escolares

Sr.Carlos Chissano

Sr.Adolfo Baltazar Miti

Sr.Rolf Lund

Sr.Vadinho Paulo J. Fernando

Sr. Pedro J. Chale

Sr.Vasco Daniel Chiponde

Sra.Alida Adamo

Sr.João Machaluco

Sr.Filipe David C.Samuel

Sr.Manuel António

DIPLAC-CEE:

Director

Chefe do Departamento

Subst.do Chefe do Departamento

Engenheiro Técnico Civil

Coordenador de Projectos

Arquitecto

Engenheira Civil

Engenheiro Civil

Arquitecto

Eng.Eletrotécnico

Dir. Nac. de Educação Geral

Sra.Palmira Gilda

Sr.Rogério Cossa

Sr. Remane Selimane

Sr.Lúcio Augusto

Sra.Maria Custódia Simeia

Sra.Maria da Glória A. Míambo

Sr.Alberto Somo Parugue

MEC DINEG

Directora

Chefe, Dep.de Ciências,Matemática e Tecnologia

Chefe, Dep.de Comunicações e Ciências Sociais, DNEG

Técnico de Química

Técnica de Biologia

Técnica de Educação Física

Técnico de Educação Física

Dir. de Administração e Finanças

Sra.Maria Celeste O. Chitará

Sr.Mikael Asén

Sr.Abílio Ernesto J. Mabe

Sr.Francisco F. Munguambe

Sr.Manuel Omar Gimo

MEC DAF

Directora, DAF

Assessor de Gestão Financeira

Chefe do Dep. de Gestão Financeiro

Chefe do Dep. de Admin. Interna

Técnico

Dir. de Recursos Humanos

Sr.Ivaldo H. de A. Quincardete

Sr.Joaquim Madavele

Mr. Nanico Regino Icheco

Sr.Samora Rungo

MEC DRH

Director

Director Adjunto p/ Formação de Professores

Chefe da Administração DHR

Técnico

Dir. Provincial da cid. de Maputo

Sr.Gedião João Jamo
 Sr.Samuel Menezes Boque
 Sr.Arlindo Constâncio Matlombe
 Sr.Rafael Chaquísse
 Sr.André Domingos Mucavele
 Sr.Adérito Olimpia Sefane

Dir. Provincial de Maputo

Sr.Fausto Sérgio de Amuldo Nativo
 Sr.Simão Albqani Chibindji
 Sr.Julião A. Simango
 Sra.Elisa Adelino Maruttici
 Sra.Inês Maria Chirine Simbine
 Sr.António Eduardo Mauelele

Dir. Provincial de Gaza

Sra. Gilda Tivane Mazuze
 Mr.Vidal Samuel Bila
 Sr.Manuel Tete
 Mr.Arnaldo Mucavele
 Sr.Octávio Manuel Joaquim
 Sr. Paulo Alberto Batalhão
 Sr.Eduardo Pedro Bila
 Sr. Jossias Nataniee Maisimbe
 Sr. Remilio Silvano Bila
 Sr. Gabriel Joao Guila
 Sr.Carlos Noa Manhumane

ESG da Cidade de Maputo

Sr. Artur Armando Dombo
 Sr.Cardoso Felisberto Ubisse
 Sr. Armindo Húo
 Sr. Jábio S. Chutumbila
 Sr. Emílio Langa
 Sra.Maimuna Amade Ibrahimio
 Sr.Jaime Rodrigues T. Nharimue
 Sr. Orlando José Dina
 Sr.Arone Chibaule

ESG da Cidade de Matola

Sr.João Alberto Pascoal
 Sr.Carlos S. Ezequias Mula
 Sr. Daudo Ussuhale
 Sr.Manuel Nhaule
 Sr.Manuel António Balate
 Sr.Olímpio Lazaro Cuna

DPEC Cidade Maputo

Director
 Chefe da Administração
 Chefe das Construções
 Técnico, Departamento Planificação
 Técnico, Departamento Pedagógico
 Técnico de Construção Civil

DPEC Maputo

Director Adjunto
 Chefe, Dep. de Planificação
 Técnico de Construções
 Técnica, Dep. de Planificação
 Directora, Serviço de Educação Juventude e Técnica SDEJT
 Secretário do Bairro Nkobe

DPEC Gaza

Directora Adjunta
 Chefe, Dep. de Planificação
 Chefe do Depart. De Planificação
 Técnico, Unidade de Construção e Equipamento Escolar
 Técnico de Construções
 Técnico de Planificação
 Director, Serviço de Educação Juventude e Técnica
 Chefe SASRH
 Chefe SAPLA
 Chefe GDM
 Técnico de Topografia

Director, ESG Quisse Mavota
 Director, ESG Zedequias Maganhela
 Director Pedagógico, ESG Magoanine
 Resp. da Secretaria, ESG Malhazine
 Director Pedagógico, ESG Mubukuwane
 Directora, ESG Jossina Machel
 Director Pedagógico, ESG Josina Machel
 Director, ESG Francisco Manyanga
 Director Ped., ESG Francisco Manyanga

Director, ESG Influene
 Director Pedagógico, ESG Matola
 Director, ESG Machava-Sede
 Director, ESG Machava Bedene
 Professor, ESG Damaso
 Director, ESG Zona Verde

ESG da prov. de Gaza

Sr.Domingos Armando Macie
Sr.Raul Augusto Ouana

Director, ESG Chissano
Director, ESG Xai-Xai

Universidade Pedagógica Maputo

Prof. Elias Narciso Matos
Dr. José Luis Barbosa

Chefe do Dep. da Planificação e Avaliação
Chefe do Dep. de Práticas Pedagógicas

Ministério de Coord. e Ambiente

Sr.Felício Fernando
Sra.Rosana Francisco

MICOA-DNAIA

Vice-Director Nacional do Estudo Ambiental
Agrónoma

Instituições internacionais

KfW
Dr.Ralf Orlik
BAD
Ms.Alice Hamer

KfW
Director of KfW Office Maputo
BAD
Resident Representative

Instituições Japonesas**Embaixado do Japão**

Sr. Sussumu Segawa
Sra.Atsuko Negami

Embaixador do Japão
Assessora p/ Cooperação Económica

JICA-Moçambique

Sr.Massami Shukunobe
Sr.Tadanobu Ono
Sr.Kenta Ono
Sra. Kyoko RILEY

Agência Japonesa de Cooperação Internacional
Representante Residente
Assistente do Representante Residente
Assistente do Representante Residente
Assessora de Formulação de Projectos

4. Minuta(M/D)

4-1 Missão do Desenho Esboço

**MINUTES OF DISCUSSIONS
ON
PREPARATORY SURVEY ON
THE PROJECT FOR
CONSTRUCTION OF SECONDARY SCHOOLS
IN MOZAMBIQUE**

Based on the results of the Preliminary Study, the Government of Japan decided to conduct a Preparatory Survey (Outline Design) on Project for construction of Secondary Schools (hereinafter referred to as "the Project") and entrusted the Survey to the Japan International Cooperation Agency (hereinafter referred to as "JICA").

JICA has sent Mozambique the Preparatory Survey Team (hereinafter referred to as "the Team"), which is headed by Mr. Masami SHUKUNOBE, Resident Representative, JICA Mozambique Office, and is scheduled to stay in Mozambique from 3rd February 2009 to 4th March 2009.

The Team held discussions with the officials concerned of the Mozambique Side and conducted field survey.

In the course of discussions and field survey, both parties confirmed the main items described on the attached sheets. The Team will proceed to further works and prepare the Preparatory Survey Report.

Maputo,
February 19, 2009

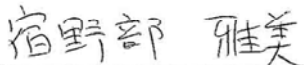

Mr. Masami SHUKUNOBE

Resident Representative,
Mozambique Office
Japan International Cooperation Agency



Ms. Maria Albertina da Conceição Bila

Permanent Secretary
Ministry of Education and Culture
Republic of Mozambique

ATTACHMENT

1. Objectives of the Project

The objective of the Project is to increase accessibility to secondary education by constructing new secondary schools.

2. Project Sites

The Sites of the Project are Maputo City, Maputo Province and Gaza Province.

3. Responsible and Implementing Organization

The responsible and implementing organization of the Project is the Ministry of Education and Culture. The organization chart of implementing organization is shown in ANNEX 1.

4. Items Requested by the Government of Mozambique

After discussions with the Team, the items described in ANNEX 2 were requested by the Mozambique side with their priorities.

JICA will assess the appropriateness of the request and will recommend to the Government of Japan for its approval.

5. Japan's Grant Aid Scheme

5-1. The Mozambique side agreed to implement the Project by the Japan's Grant Aid Scheme for Community Empowerment.

5-2 The Mozambique side understood the Japan's Grant Aid Scheme for Community Empowerment described in ANNEX 3-1 and ANNEX 3-2, which were explained by the Team.

5-3. The Mozambique side assured to take the necessary measures, as described in ANNEX 4, for smooth implementation of the Project.

6. Schedule of the Study

6-1. The Consultant members of the Team will proceed to undertake further studies in Mozambique until 4th March 2009.

6-2. Based on the results of a field survey in Mozambique, the Team will continue the Survey in Japan until May, 2009. JICA will dispatch the draft report explanation mission to Mozambique in May, 2009.

7. Contents of the Survey

Mozambique side understood the contents of the Survey noted in the Inception Report, which submitted by the Team on 4th February 2009.

8. Other Relevant Issues

8-1 Deed Titles

Mozambique side agreed to submit the deed titles of the sites (Chissano and Manjakaze) by 3rd March 2009.

8-2 Laboratories, Information Rooms and Libraries

(1) Both sides agreed that the multi purpose rooms would be designed instead of the laboratories, the information rooms and the libraries.

(2) Mozambique side agreed to allocate appropriate budget and qualified teachers for utilization of the laboratories, the information rooms and the libraries. In case the allocation regarded as insufficient, both sides agreed to reconsider appropriateness of them as the components of the Project.

8-3 Relevant issues on the necessary measures to be taken by Mozambique side

Regarding on the Annex 4 "Major undertakings to be taken by each government", the followings are reconfirmed to be included in them.

(1) Water Supply

➤ Provision of water supply facilities to the receiving tanks in the sites

- Construction of adequate number of boreholes at the sites, where water supply are not in service, before the tenders for the construction works of the Project.
- (2) **Electricity**
 - Provision of distribute lines with adequate capacity to the sites
- (3) **Clearance, leveling and reclamation of the sites**
 - Removal of obstacles such as trees' roots and rocks
- (4) **Access Roads**
 - Construction of access road to the sites
- (5) **Tax Exemption**
 - Allocation of sufficient MEC's budget to substitute internal taxes such as VAT with respect to the supply of the products and services for the Project
- (6) **Others**
 - Preparation of temporary classrooms and other necessary facilities during construction works

8-4 Committee and focal person(s) for implementation of the Project

To implement the project smoothly, both sides agreed to set and facilitate a committee composed of the government of Mozambique, the government of Japan and JICA. Mozambique side also agreed to assign staff in DIPLAC as the focal person(s) of the Project.

8-5 Technical specifications for the school furniture of the Project

Both sides agreed that Mozambique side would prepare the technical specifications of the school furniture and the appointed procurement agent would finalize the tender document for the Project in cooperation with the Mozambique side agencies concerned.

8-6 Technical designs for the school buildings of the Project

Mozambique side mentioned that DIPLAC would review and authorize the references for the tender document prepared in the Survey.

8-7 JICA guidelines for Environmental and Social Considerations

The Team explained outline of the JICA guidelines for Environmental and Social Considerations and the need to comply with it in the implementation of the Project. Both sides confirmed to work together to adopt the approach specified by the regulation of Mozambique and the guideline of JICA.

8-8 Local Consultants

Both sides recognized advantages of continuous involvement of the consultants in detail design and supervision.

8-9 Unified environment as secondary schools

Both sides recognized importance of site plans and facilities such as corridors and gardens to create unified environment as secondary schools.

ANNEX 1: Organization Chart of Ministry of Education and Culture, Mozambique

ANNEX 2: Requested Items and Priority

ANNEX 3-1: The Japan's Grant Aid for Community Empowerment

ANNEX 3-2: Flow of Funds for implementation under the Japan's Grant Aid for Community Empowerment

ANNEX 4: Major Undertakings by each Government

ANNEX 5: Implementation Flow of Grant Aid for Community Empowerment

ANNEX 1: Organization Chart of the Ministry of Education and Culture

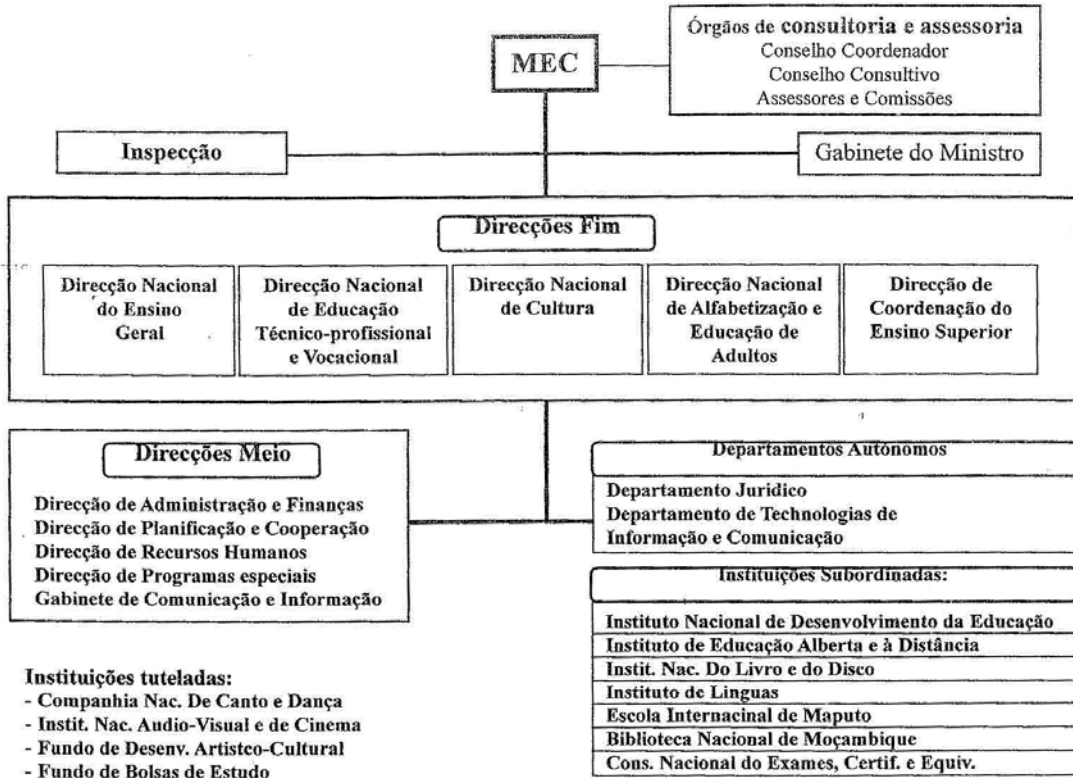

ANNEX 2

Requested Items and Priority

■ 1st Priority

● Construction

Name	Location	Classroom	Multi Purpose Block	Administration Block	Toilet Block
Ndobe (Cobe)	Matola - Machava	15	1	1	1
Kongolote	Matola - Kongolote	20	1	1	1
Chissano	Gaza - Bilene	8	1	1	1
Manjakaze	Gaza - Manjakaze	15	1	1	1

*The multi purpose block is utilized as laboratory, information room and library.

● School Furniture

a. Classroom	<ul style="list-style-type: none"> ✓ Desks and chairs for pupils ✓ Desks and chairs for teachers ✓ Blackboard ✓ Notice board
b. Multi Purpose Block	<ul style="list-style-type: none"> ✓ Tables and chairs for teacher ✓ Work Tables or desks and chairs for pupils ✓ Shelves
c. Administration rooms	<ul style="list-style-type: none"> ✓ Desks, Chairs and Cabinets for director's office ✓ Desks, Chairs and Cabinets for administration office rooms ✓ Desks, Chairs and Cabinets for teachers rooms ✓ Table and chairs for meeting room ✓ Lockers

■ 2nd Priority

● Construction

Sub Priority	Name	Location	Covered Sports Field (with Changing Room)
1	Manjakaze	Gaza - Manjakaze	1
2	Kongolote	Matola - Kongolote	1
3	Ndobe (Cobe)	Matola - Machava	1
4	Chissano	Gaza - Bilene	1

■ 3rd Priority

● Construction

Name	Location	Classroom	Multi Purpose Block	Toilet Block	Administration Block
Matendene	C. Maputo - Magoanine	10	1	1	1

*With school furniture noted in 1st priority

■ 4th Priority

● Construction

Name	Location	Teachers House
Chissano	Gaza - Bilene	6
Manjakaze	Gaza - Manjakaze	6
Ndobe (Cobe)	Matola - Machava	1
Kongolote	Matola - Kongolote	1

Japan's Grant Aid Scheme for Community Empowerment (Tentative)

The Government of Japan (hereinafter referred to as "the GOJ") is implementing the organizational reforms to improve the quality of ODA operations, and as part of this realignment, JICA was reorganized on October 1, 2008. After the reorganization of JICA, following the decision of the GOJ, Grant Aid is extended by JICA.

Grant Aid is non-reimbursable fund to the government of the recipient country to procure the facilities, equipment and services (engineering services and transportation of the products, etc.) for economic and social development of the country under principles in accordance with the relevant laws and regulations of Japan. The Grant Aid is not supplied through the donation of materials as such.

The Grant Aid scheme for Community Empowerment (hereinafter referred to as "GACE") aims toward development of communities by empowering their capability as a whole to assure the sustainable development and overcome various threats, thus seeks to enhance human security. Multiple components can be combined to effectively meet the needs of communities. Contractors, suppliers or consultants are not confined to Japanese firms only, and construction can be done based on the local method, which leads to cost reduction.

1. Grant Aid Procedure

The Japanese Grant Aid is conducted as follows-

- Preparatory Survey (hereinafter referred to as "the Survey")
 - the Survey conducted by JICA
- Appraisal & Approval
 - Appraisal by the GOJ and JICA, and Approval by the Japanese Cabinet
- Determination of Implementation
 - The Notes (hereinafter referred to as "the E/N") exchanged between the GOJ and a recipient country
- Grant Agreement (hereinafter referred to as "the G/A")
 - Agreement concluded between JICA and a recipient country
- Implementation
 - Implementation of the Project on the basis of the G/A

2. Preparatory Survey

1) Contents of the Survey

The aim of the Survey is to provide a basic document necessary for the appraisal of the Project

by JICA and the GOJ. The contents of the Survey are as follows:

- (1) Confirmation of the background, objectives, and benefits of the Project and also institutional capacity of agencies and communities concerned of the recipient country necessary for the implementation of the Project.
- (2) Evaluation of the appropriateness of the Project to be implemented under the GACE from a technical, financial, social and economic point of view;
- (3) Confirmation of items agreed on by both parties concerning the basic concept of the Project.
- (4) Preparation of an outline design of the Project.

(5) Estimation of cost for the Project.

The contents of the original request by the government of the recipient country are not necessarily approved in their initial form as the contents of the Grant Aid project. The Outline Design of the Project is confirmed considering the guidelines of Japan's Grant Aid scheme.

JICA requests the Government of the recipient country to take whatever measures are necessary to ensure its self-reliance in the implementation of the Project. Such measures must be guaranteed even though they may fall outside of the jurisdiction of the organization in the recipient country actually implementing the Project. Therefore, the implementation of the Project is confirmed by all relevant organizations of the recipient country through the Minutes of Discussions.

2) Selection of Consultants

For smooth implementation of the Survey, JICA uses (a) registered consulting firm(s). JICA selects (a) firm(s) based on proposals submitted by interested firms.

3) Result of the Survey

The Report on the Survey is reviewed by JICA, and after The firm(s) selected carry(ies) out the Survey and write(s) a report, based upon terms of reference set by JICA. The appropriateness of the Project is confirmed, JICA recommends to the GOJ to appraise the implementation of the Project.

3. Japan's Grant Aid Scheme

1) The E/N and G/A

After the project approved by the Cabinet of Japan, the E/N will be signed between the GOJ and the Government of the recipient country to make a plea for assistance, which is followed by the conclusion of the G/A between JICA and the Government of the recipient country to define the necessary articles to implement the Project, such as payment conditions, responsibilities of the Government of the recipient country, and procurement conditions.

2) Necessity of "Verification"

The Government of the recipient country or its designated authority will conclude contracts denominated in Japanese yen. Those contracts shall be verified by JICA. This "Verification" is deemed necessary to secure accountability to Japanese taxpayers.

3) Major undertakings to be taken by the Government of the recipient country

In the implementation of the Grant Aid Project, the government of the recipient country is required to undertake such necessary measures as ANNEX 4.

4) "Proper Use"

The Government of the recipient country is required to maintain and use the facilities constructed and the equipment purchased under the Grant Aid properly and effectively and to assign staff necessary for this operation and maintenance as well as to bear all the expenses other than those covered by the Grant Aid.

5) "Export and Re-export"

The products purchased under the Grant Aid should not be exported and re-exported from the recipient country.

6) Banking Arrangements (B/A)

The Government of the recipient country or its designated authority should open an account in the name of the Government of the recipient country in a bank in Japan (hereinafter referred to as "the Bank"). JICA will execute the Grant Aid by making payments in Japanese yen to cover the obligations incurred by the Government of the recipient country or its designated authority under the Verified Contracts.

7) Payment Commission

The Government of the recipient country should bear payment commissions to the Bank for the transfer of the grant funds.

8) Social and Environmental Considerations

The recipient country must ensure the social and environmental considerations for the Project and must follow the environmental regulation of the recipient country and JICA socio-environmental guideline.

4. Implementation of GACE after the E/N and the G/A

1) Procedural details

Essential points to be agreed upon are outlined as follows:

- a) JICA executes the Grant by making payments of the amount agreed upon in the E/N and pays serious attention to ensure the accountability on proper and effective use of the Grant for the Project / the Programme.
- b) The products and services shall be procured and provided in accordance with "Procurement Guidelines for Grant Aid for Community Empowerment".
- c) The Government of the recipient country shall conclude an employment contract with the Agent.
- d) The Government of the recipient country shall designate the Agent as the representative acting in the name of the Government of the recipient country concerning all transfers of funds to the Agent.

2) Focal Points of "Procurement Guidelines for Grant Aid for Community Empowerment"

a) The Agent

The Agent is the organization which provides procurement services of products and services on behalf of the Government of the recipient country according to the Agent Agreement with the Government of the recipient country. The Agent is recommended to the Government of the recipient country by JICA and agreed between the two Governments in the Agreed Minutes (A/M).

b) Agent Agreement

The Government of the recipient country shall conclude an Agent Agreement, within two month after the date of entry into force of the G/A. The scope of the Agent's services shall be clearly specified in the Agent Agreement.

c) Approval of the Agent Agreement

The Agent Agreement, which is prepared as two identical documents, shall be submitted to JICA by the Government of the recipient country through the Agent. JICA confirms whether or not the Agent Agreement is concluded in conformity with the E/N and the G/A and the Procurement Guidelines for Grant Aid for Community Empowerment, and approves the contract.

The Agent Agreement concluded between the Government of the recipient country and the Agent shall become effective after the approval by JICA in a written form.

(M)

(B)

d) Payment Methods

The Agent Agreement shall stipulate that "regarding all transfers of the fund to the Agent, the Government of the recipient country shall designate the Agent to act on behalf of the Government of the recipient country and issue a Blanket Disbursement Authorization ("the BDA") to conduct the transfer of the fund (Advances) to the Procurement Account from the Recipient Account."

The Agent Agreement shall clearly state that the payment to the Agent shall be made in Japanese yen from the Advances and that the final payment to the Agent shall be made when the total Remaining Amount become less than 3 % of the Grant and its accrued interest.

e) Products and Services Eligible for Procurement

Products and services to be procured shall be selected from those defined in the G/A.

f) Firm

In principle, a Firm of any nationality could be contracted as long as the Firm satisfies the conditions specified in the tender documents.

g) Method of Procurement

In implementing procurement, sufficient attention shall be paid so that there is no unfairness among tenderers who are eligible for the procurement of products and services.

For this purpose, competitive tendering shall be employed in principle.

h) Tender Documents

The tender documents should contain all information necessary to enable tenderers to prepare valid offers for the products and services to be procured by GACE.

The rights and obligations of the Government of the recipient country, the Agent and the Suppliers of the products and services should be stipulated in the tender documents to be prepared by the Agent. Besides this, the tender documents shall be prepared in consultation with the the Government of the recipient country.

i) Pre-qualification Examination of Tenderers

The Agent may conduct a pre-qualification examination of tenderers in advance of the tender so that the invitation to the tender can be extended only to eligible firms. The pre-qualification examination should be performed only with respect to whether or not the prospective tenderers have the capability of accomplishing the contracts concerned without fail. In this case, the following points should be taken into consideration:

- (1) Experience and past performance in contracts of a similar kind
- (2) Property foundation or financial credibility
- (3) Existence of offices, etc. to be specified in the tender documents.

j) Tender Evaluation

The tender evaluation should be implemented on the basis of the conditions specified in the tender documents.

Those tenders which substantially conform to the technical specifications, and are responsive to other stipulations of the tender documents, shall be judged in principle on the basis of the submitted price, and the tenderer who offers the lowest price shall be designated as the successful tenderer.

The Agent shall prepare a detailed tender evaluation report clarifying the reasons

for the successful tender and the disqualification and submit it to the Government of the recipient country to obtain confirmation before concluding the contract with the successful tenderer.

The Agent shall, before a final decision on the award is made, furnish JICA with a detailed evaluation report of tenders, giving the reasons for the acceptance or rejection of tenders.

k) Additional Procurement

If there is an additional procurement fund after competitive and / or selective tendering and / or direct negotiation for a contract, and the Government of the recipient country would like an additional procurement, the Agent is allowed to conduct an additional procurement, following the points mentioned below:

(1) Procurement of the same products and services

When the products and services to be additionally procured are identical with the initial tender and a competitive tendering is judged to be disadvantageous, the additional procurement can be implemented by a direct contract with the successful tenderer of the initial tender.

(2) Other procurements

When products and services other than those mentioned above in (1) are to be procured, the procurement should be implemented through a competitive tendering. In this case, the products and services for additional procurement shall be selected from among those in accordance with the E/N and G/A.

l) Conclusion of the Contracts

In order to procure products and services in accordance with the E/N and the G/A, the Agent shall conclude contracts with firms selected by tendering or other methods.

m) Terms of Payment

The contract shall clearly state the terms of payment. The Agent shall make payment from the "Advances", against the submission of the necessary documents from the Firm on the basis of the conditions specified in the contract, after the obligations of the Firm have been fulfilled. When the services are the object of procurement, the Agent may pay certain portion of the contract amount in advance to the firms on the conditions that such firms submit the advance payment guarantee worth the amount of the advance payment to the Agent.

END



ANNEX 3-2 Flow of Funds for implementation under the Japan's Grant Aid for Community Empowerment

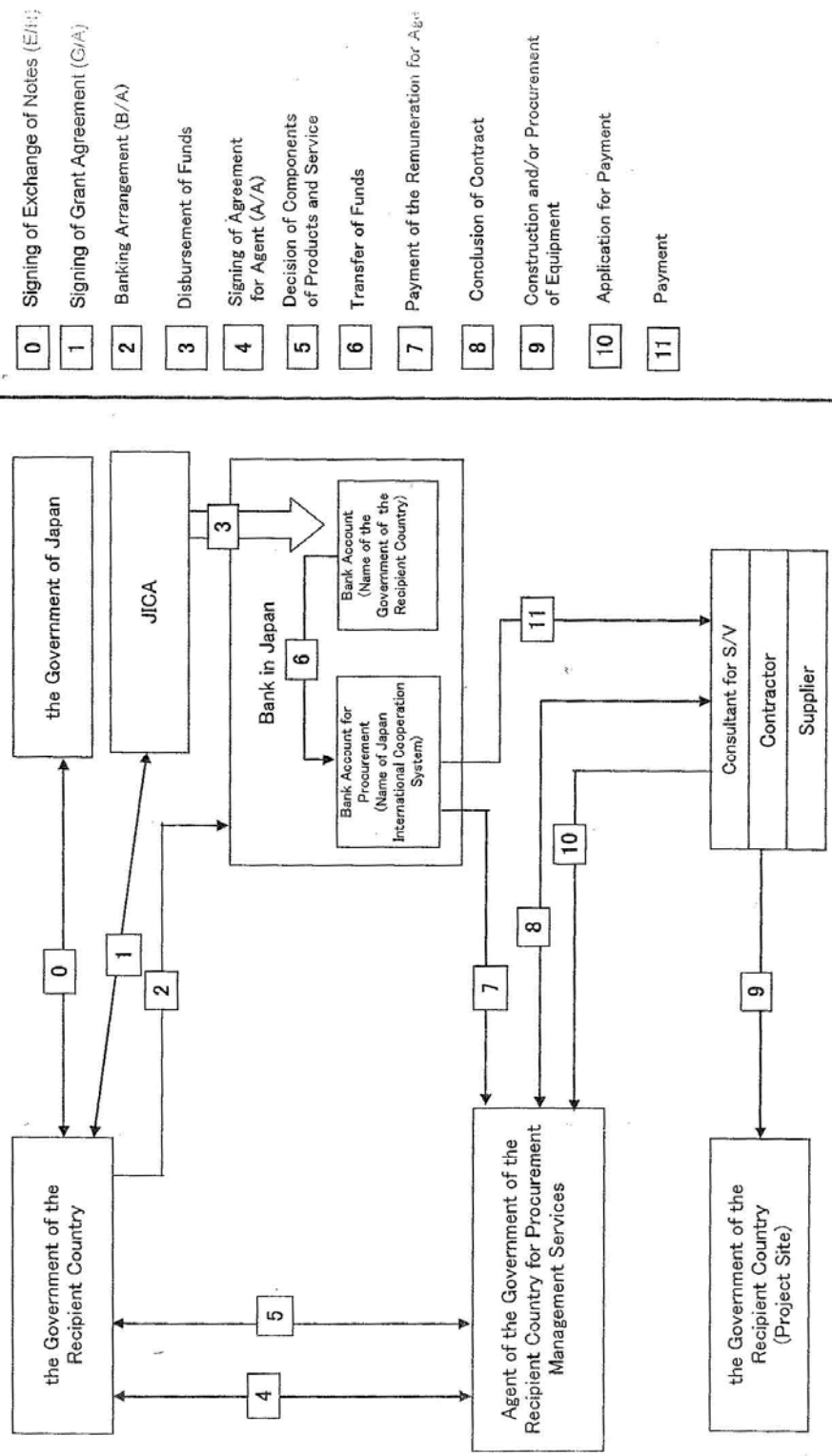

Major Undertakings to be taken by Each Government

No	Items	To be covered by Grant Aid	To be covered by Recipient Side
1	To secure land		●
2	To clear, level and reclaim the site when needed		●
3	To construct gates and fences in and around the site		●
4	To construct the parking lot	●	
5	To construct roads		
	1) Within the Site	●	
	2) Outside the site		●
6	To construct the buildings	●	
7	To provide facilities for the distribution of electricity, water supply, drainage and other incidental facilities		
	1) Electricity		
	a. The distributing line to the site		●
	b. The drop wiring and internal wiring within the site	●	
	c. The main circuit breaker and transformer	●	
	2) Water Supply		
	a. The city water distribution main to the site		●
	b. The supply system within the site (receiving and elevated tanks)	●	
	3) Drainage		
	a. The city drainage main (for storm, sewer and others)		●
	b. The drainage system (for toilet sewer, ordinary waste, storm drainage and others) within the site	●	
	4) Gas Supply		
	a. The city gas main to the site	n.a.	n.a.
	b. The gas supply system within the site	n.a.	n.a.
	5) Telephone System		
	a. The telephone trunk line to the main distribution frame/panel (MDF) of the building		●
	b. The MDF and the extension after the frame/panel	●	
	6) Furniture and Equipment		
	a. General furniture		●
	b. Project equipment (School furniture)	●	
8	To bear the commissions to the Japanese bank for banking services based upon the B/A		●
9	To ensure unloading and customs clearance at port of disembarkation in recipient country		
	1) Marine (Air) transportation of the products from abroad to the recipient country	●	
	2) Tax exemption and custom clearance of the products at the port of disembarkation		●
	3) Internal transportation from the port of disembarkation to the project site	●	
10	To accord Japanese nationals and/or nationals of third countries, including such nationals employed by the Agent or the consultants whose services may be required in connection with the supply of the products and the services under the verified contract such facilities as may be necessary for their entry into the recipient country and stay therein for the performance of their work		●
11	To exempt customs duties, internal taxes and other fiscal levies which may be imposed in the recipient country with respect to the supply of the products and services for the Project		●
12	To maintain and use properly and effectively the facilities constructed and equipment provided under the Grant Aid		●
13	To bear all the expenses, other than those to be borne by the Grant Aid, necessary for the transportation and installation of the equipment.		●

(B/A: Banking Arrangement)

Implementation Flow of Grant Aid for Community Empowerment

1	Conclusion of Exchange of Notes (E/N)	The Government of Recipient Country and the Government of Japan conclude Exchange of Notes (E/N) after approval of the Grant for community empowerment by the Government of Japan.
2	Conclusion of Grant Agreement (G/A)	The Government of Recipient Country and JICA conclude Grant Agreement (G/A) after conclusion of the E/N to define the necessary articles to implement the Project.
3	Conclusion of Banking Arrangement (B/A)	The Recipient Government and a bank in Japan (the Bank of Tokyo-Mitsubishi, UFJ) conclude Banking Arrangement (B/A) to open an account in the name of the Recipient Government. The account is called 'Recipient Account'.
4	Disbursement of Funds	Following the E/N and B/A, the total amount of the grant is transferred into the 'Recipient Account'.
5	Conclusion of Agent Agreement (A/A)	As soon as the Exchange of Notes (E/N) is signed, the appointed procurement agent concludes an Agent Agreement (A/A) with the Recipient Government. The appointed procurement agent will explain about procurement procedures, responsibilities of the Recipient Government and the appointed procurement agent, and remuneration as an Agent.
6	Transfer of the Grant Funds	Before starting procurement services, the grant funds are transferred from the 'Recipient Account' to 'The appointed procurement agent's procurement account'. The appointed procurement agent then takes full responsibility for managing the grant funds until payment is completed for the procurement services. By signing Blanket Disbursement Authorization (BDA), the Recipient Government designates the appointed procurement agent as their representative and gives authorities to transfer all the funds under this project on behalf of the Recipient Government.
7	Payment of Agent's Fee	The Recipient Government shall pay the appointed procurement agent Agent's Fee for its services to be rendered pursuant to the Agent Agreement. Agent's Fee shall be paid to the appointed procurement agent from the fund transferred to 'The appointed procurement agent procurement account'.
8	Selection of a Consultant for Detail Design and Supervision	The appointed procurement agent selects a consultant for Supervision in the proper manner based on the research results of the Outline Design Study.
9	Selection of Contractors	The appointed procurement agent selects contractors, utilizing research results provided by the consultant.
	(1) Tender document preparation	The appointed procurement agent prepares tender documents for selecting contractors based on the results of Outline Design Study and information provided by the consultant.
	(2) General Procurement Notice (GPN) and Pre-qualification of Prospective Tenderers	The appointed procurement agent advertises for tenders by means of GPN in widely read newspapers and the appointed procurement agent website. The appointed procurement agent then assesses the eligibility of registered companies for tender.
	(3) Tender and Tender Evaluation	The appointed procurement agent conducts a tender by International Competitive Bidding (ICB) or other appropriate manners. The tender is evaluated by the appointed procurement agent and a successful tenderer is determined based on agreement made among the concerned parties.
	(4) Conclusion of Contract	Contract is concluded between the appointed procurement agent and the successful tenderer.
10	Procurement of Goods	The appointed procurement agent procures equipment agreed to be procured for the project in the following manner.
	(1) Tender document preparation	Same as No. 8.
	(2) General Procurement Notice (GPN) and Pre-qualification of Prospective Tenderers	

	(3) Tender and Tender Evaluation	
	(4) Conclusion of Contract	
11	School Construction and Delivery of Goods	The appointed procurement agent informs the Recipient Government of the construction and delivery schedule. If any problem should occur, the appointed procurement agent cooperates with the Recipient Government, JICA and Japanese Embassy in order to solve the problem in accordance with the contract. The Recipient Government shall take necessary measures to ensure smooth customs clearance and tax exemption.
12	Payment for Goods and Services	When necessary documents for payment are submitted by a contractant (consultant, supplier, contractor), the appointed procurement agent examines their contents and, if satisfactory, makes payment from the ' The appointed procurement agent T Procurement Account' to the contractant.
13	Implementation of Soft Component Program	In case that a soft component program is implemented, the appointed procurement agent selects NGOs or other agencies for its implementation, concludes a contract and makes a payment.

(Handwritten mark)

(Handwritten mark)