

資料 7-7 設計図面集

## 図面目録

| 図面番号      | 図面名称            | 枚数 |
|-----------|-----------------|----|
| CG-BD-A1  | 目次              | 1  |
| CG-BD-B1  | 位置図             | 1  |
| CG-BD-C1  | 標準断面            | 2  |
| CG-BD-D1  | 平面・縦断図          | 18 |
| CG-BD-D19 | 交差点平面図          | 2  |
| CG-BD-E1  | 排水工 1：U型側溝      | 1  |
| CG-BD-E2  | 排水工 2：集水枿       | 1  |
| CG-BD-E3  | 排水工 3：ボックスカルバート | 1  |
| CG-BD-F1  | 付帯工 1：バス停       | 2  |
| CG-BD-F3  | 付帯工 2：駐車帯       | 1  |
| CG-BD-F4  | 付帯工 3：非常駐車帯     | 2  |
| CG-BD-F6  | 付帯工 4：取付道路      | 3  |
| CG-BD-F9  | 付帯工 5：防護柵       | 1  |
| CG-BD-F10 | 付帯工 6：交通標識      | 2  |
| CG-BD-F12 | 付帯工 7：区画線       | 1  |
| CG-BD-F13 | 付帯工 8：縁石        | 1  |
| CG-BD-F14 | 付帯工 9：擁壁        | 1  |
| CG-BD-F15 | 付帯工 10：鉄道横断     | 2  |
| 合 計       |                 | 43 |

L'ETUDE PREPARATOIRE  
POUR  
LE PROJET DE REHABILITATION ET DE MODERNISATION  
DE L'AVENUE DES POIDS LOURDS A KINSHASA  
EN  
REPUBLIQUE DEMOCRATIQUE DU CONGO

PLANCHES

2009

AGENCE JAPONAISE DE COOPERATION INTERNATIONALE  
INGEROSEC CORPORATION, JAPON

# TABLE DES MATIÈRES

## TITRE DES PLANS

## NO. PLAN

|                |                                       |
|----------------|---------------------------------------|
| CG-BD A1       | TABALE DES MATIERES                   |
| CG-BD B1       | PLAN DE POSITIONNEMENT                |
| CG BD C1       | PROFILS EN TRAVERS TYPE-1             |
| CG BD C3       | PROFILS EN TRAVERS TYPE -2            |
| CG BD C3       | PROFILS EN TRAVERS TYPE -3            |
| CG BD D1 – D18 | PLAN ET PROFIL(1/18)-(18/18)          |
| CG BD D19      | PLAN DU CARREFOUR FORCE NAVAL         |
| CG BD D20      | PLAN DU CARREFOUR 14em RUE            |
| CG BD E1       | DRAINAGE (1)                          |
| CG BD E2       | DRAINAGE (2)                          |
| CG BD E3       | DRAINAGE (3)                          |
| CG BD F1       | PLAN DE ARRET DE BUS (TYPE1)          |
| CG BD F2       | PLAN DE ARRET DE BUS (TYPE2)          |
| CG BD F3       | PLAN DE L'AIRE DE STATIONNEMENT       |
| CG BD F4       | PLAN D'AIRE D'ARRET D'URGENCE (TYPE1) |
| CG BD F5       | PLAN D'AIRE D'ARRET D'URGENCE (TYPE2) |
| CG BD F6       | ROUTE D'ACCES (TYPE1)                 |
| CG BD F7       | ROUTE D'ACCES (TYPE2)                 |
| CG BD F8       | ROUTE D'ACCES (TYPE3)                 |
| CG BD F9       | GARDE BALISE                          |
| CG BD F10      | PANNEAU DE SIGNALISATION (1)          |
| CG BD F11      | PANNEAU DE SIGNALISATION (2)          |
| CG BD F12      | MARQUAGES AU SOL                      |
| CG BD F13      | BORDURE                               |
| CG BD F14      | DETAILS DU PASSAGE A NIVEAU           |
| CG BD F15      | DETAILS DU PASSAGE A NIVEAU           |

|   |                                     |  |                                 |              |  |                  |          |      |          |
|---|-------------------------------------|--|---------------------------------|--------------|--|------------------|----------|------|----------|
| AGENCE JAPONAISE DE<br>COOPERATION INTERNATIONALE | REPUBLIQUE<br>DEMOCRATIQUE DU CONGO | L'ETUDE PREPARATOIRE POUR<br>LE PROJET DE REHABILITATION ET<br>DE MODERNISATION DE L'AVENUE<br>DES POIDS LOURDS A KINSHASA | INGEROSEC CORPORATION,<br>JAPON | DATE:        |  | TABLE DE MATIERE | ECHELLE  | DATE | N°       |
|   |                                     |  |                                 | PREPARE PAR: |  |                  | COMME VU | 2009 | CG-BD-A1 |
|   |                                     |  |                                 | VERIFIE PAR: |  |                  |          |      |          |



AGENCE JAPONAISE DE  
COOPERATION INTERNATIONALE

REPUBLIQUE  
DEMOCRATIQUE DU CONGO

L'ETUDE PREPARATOIRE POUR  
LE PROJET DE REHABILITATION ET  
DE MODERNISATION DE L'AVENUE  
DES POIDS LOURDS A KINSHASA

INGEROSEC CORPORATION,  
JAPON

DATE:  
PREPARE PAR:  
VERIFIE PAR:

PLAN DE POSITIONNEMENT

ECHELLE  
COMME VU

DATE  
2009

N°  
CG-BD-A2

# PROFIL EN TRAVERS TYPE

ECHELLE A1 1:100  
A3 1:200

CAS DU POTEAU ÉLECTRIQUE SUR LE TROTTOIR  
PK3+540 – PK10+330

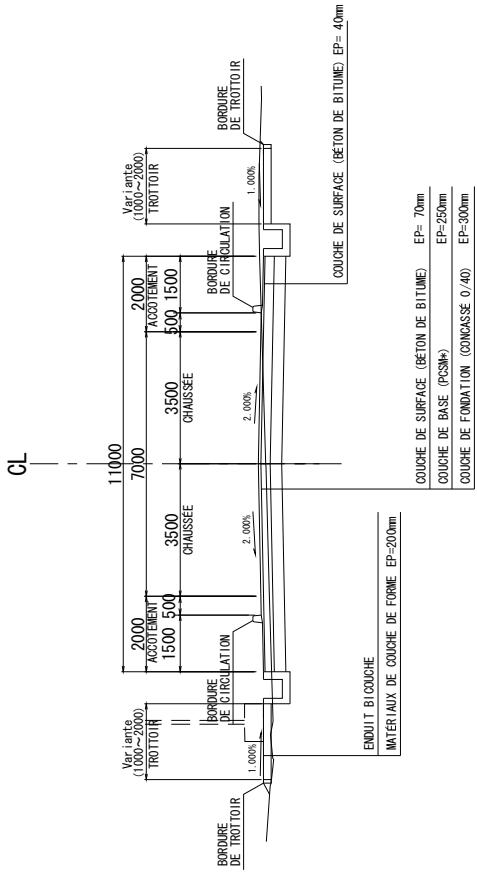

CAS DU POTEAU ÉLECTRIQUE HORS DU TROTTOIR  
PK3+540 – PK10+330

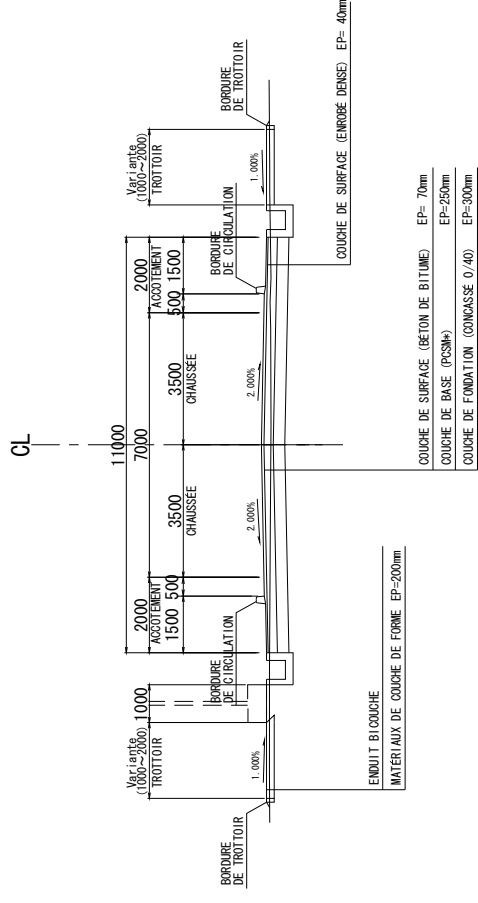

PK0+000 – PK2+900

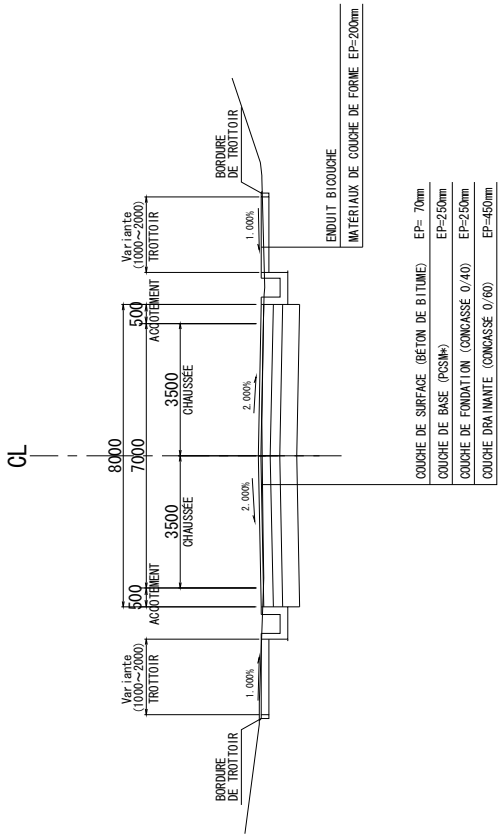

PK2+900 – PK3+540

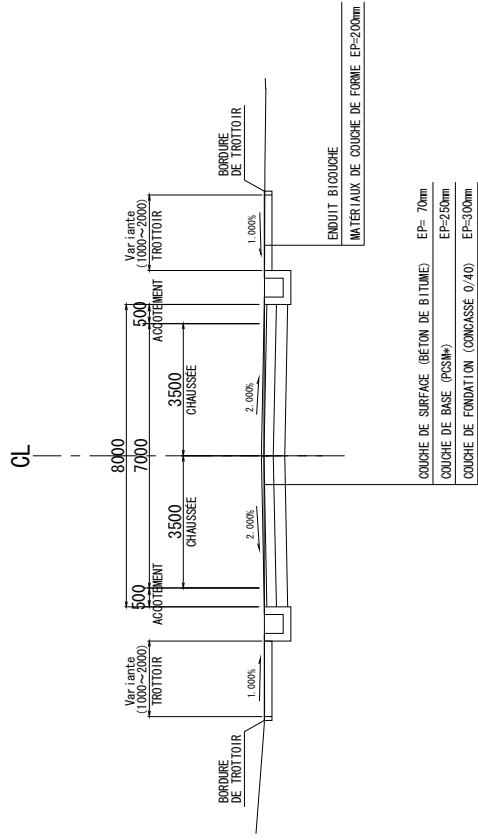

PCSM\* : PIERRES CONCASSÉES POUR STABILISATION MÉCANIQUE

|  |                                  |   |                              |                              |          |      |          |
|--|----------------------------------|---|------------------------------|------------------------------|----------|------|----------|
| AGENCE JAPONAISE DE COOPERATION INTERNATIONALE | REPUBLIQUE DEMOCRATIQUE DU CONGO | L'ETUDE PREPARATOIRE POUR LE PROJET DE REHABILITATION ET DE MODERNISATION DE L'AVENUE DES POIDS LOURDS A KINSHASA | INGEROSEC CORPORATION, JAPON | DATE:                        | ECHELLE  | DATE | N°       |
|  |                                  |   |                              | PREPARE PAR:<br>VERIFIE PAR: | COMME VU | 2009 | CG-BD-C1 |

# PROFIL EN TRAVERS TYPE

ECHELLE A1 1:100  
A3 1:200

PK3+540 - PK10+330

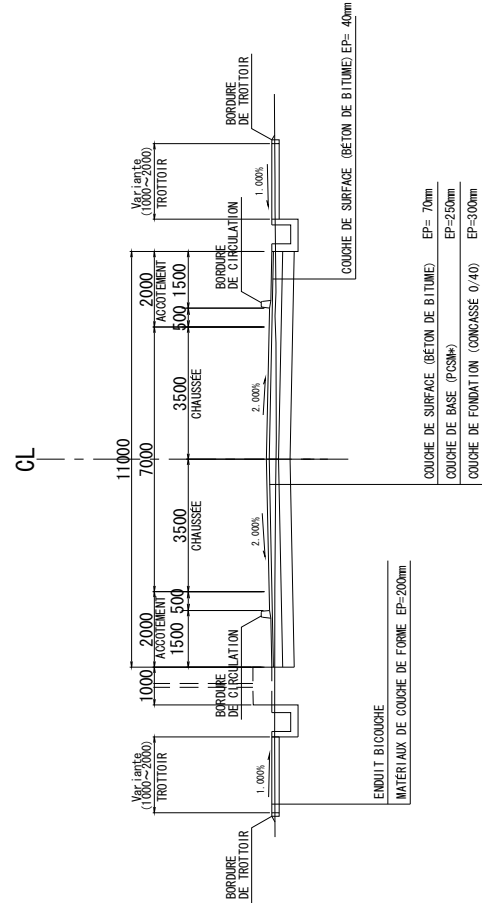

PK10+330 - PK11+327

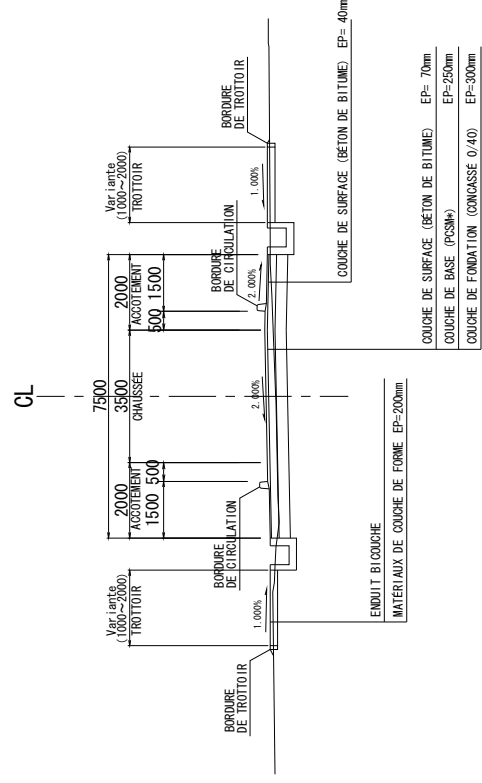

PK0+000 - PK0+602

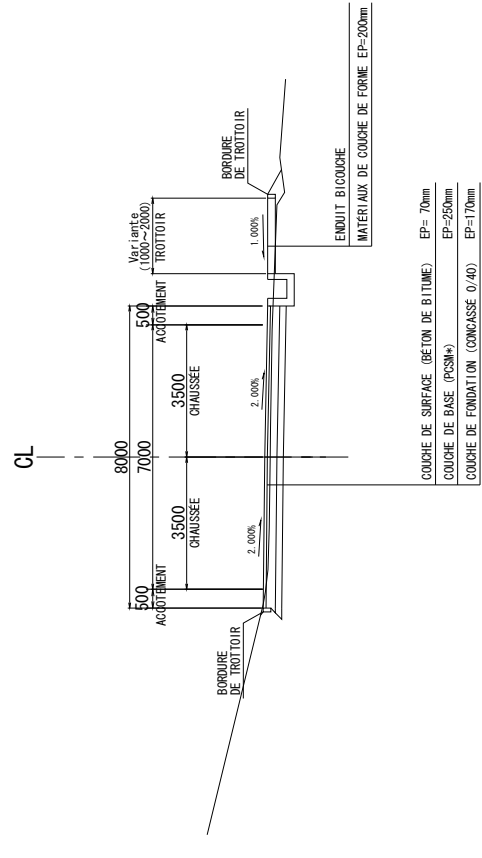

PCSM\* : PIERRES CONCASSES POUR STABILISATION MECANIQUE

|  |                                  |   |                              |                              |          |      |          |
|--|----------------------------------|---|------------------------------|------------------------------|----------|------|----------|
| AGENCE JAPONAISE DE COOPERATION INTERNATIONALE | REPUBLIQUE DEMOCRATIQUE DU CONGO | L'ETUDE PREPARATOIRE POUR LE PROJET DE REHABILITATION ET DE MODERNISATION DE L'AVENUE DES POIDS LOURDS A KINSHASA | INGEROSEC CORPORATION, JAPON | DATE:                        | ECHELLE  | DATE | N°       |
|  |                                  |   |                              | PREPARE PAR:<br>VERIFIE PAR: | COMME VU | 2009 | CG-BD-C2 |

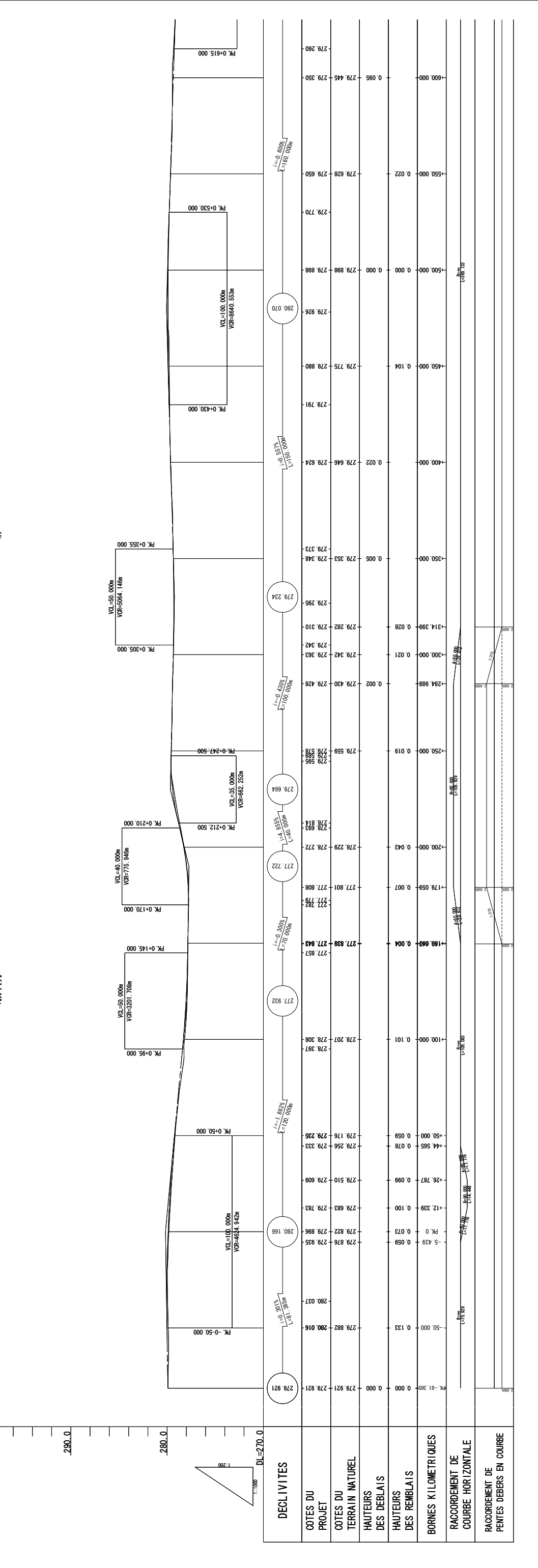
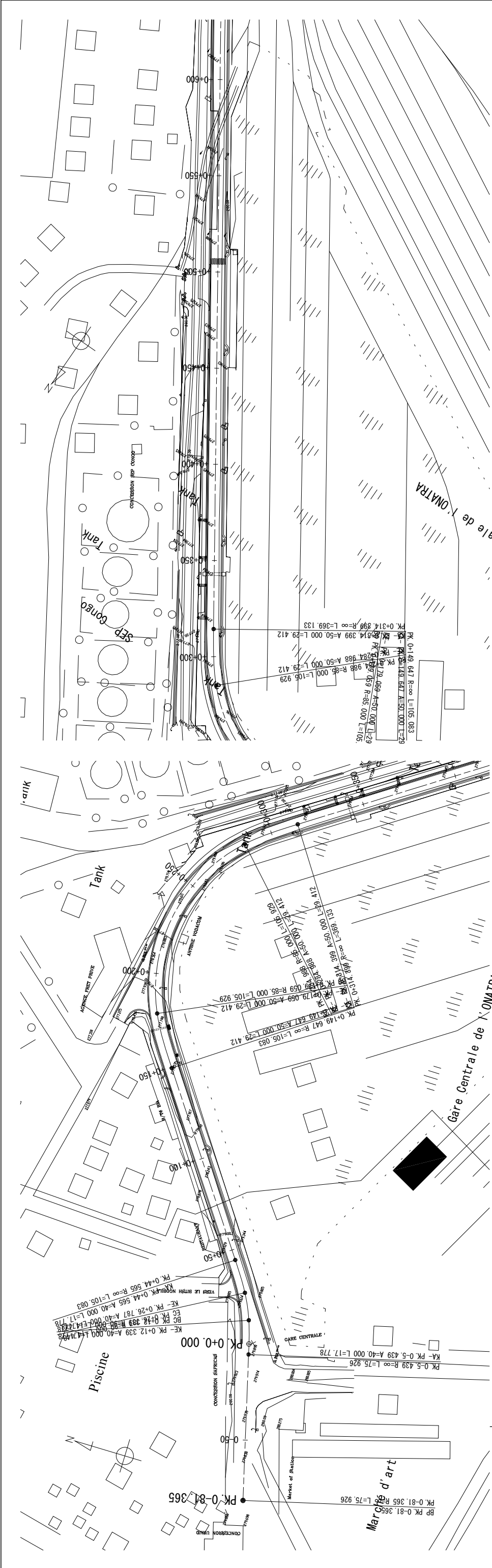

|  |                                  |   |                              |                              |  |                                     |              |                |
|--|----------------------------------|---|------------------------------|------------------------------|--|-------------------------------------|--------------|----------------|
| AGENCE JAPONAISE DE COOPERATION INTERNATIONALE | REPUBLIQUE DEMOCRATIQUE DU CONGO | L'ETUDE PREPARATOIRE POUR LE PROJET DE REHABILITATION ET DE MODERNISATION DE L'AVENUE DES POIDS LOURDS A KINSHASA | INGEROSEC CORPORATION, JAPON | DATE:                        | PLAN ET PROFIL (1/18)<br>PK.0+000 - PK.0+600 | ECHELLE<br>A1-1:1.000<br>A3-1:2.000 | DATE<br>2009 | N°<br>CG-BD-D1 |
|  |                                  |   |                              | PREPARE PAR:<br>VERIFIE PAR: |  |                                     |              |                |



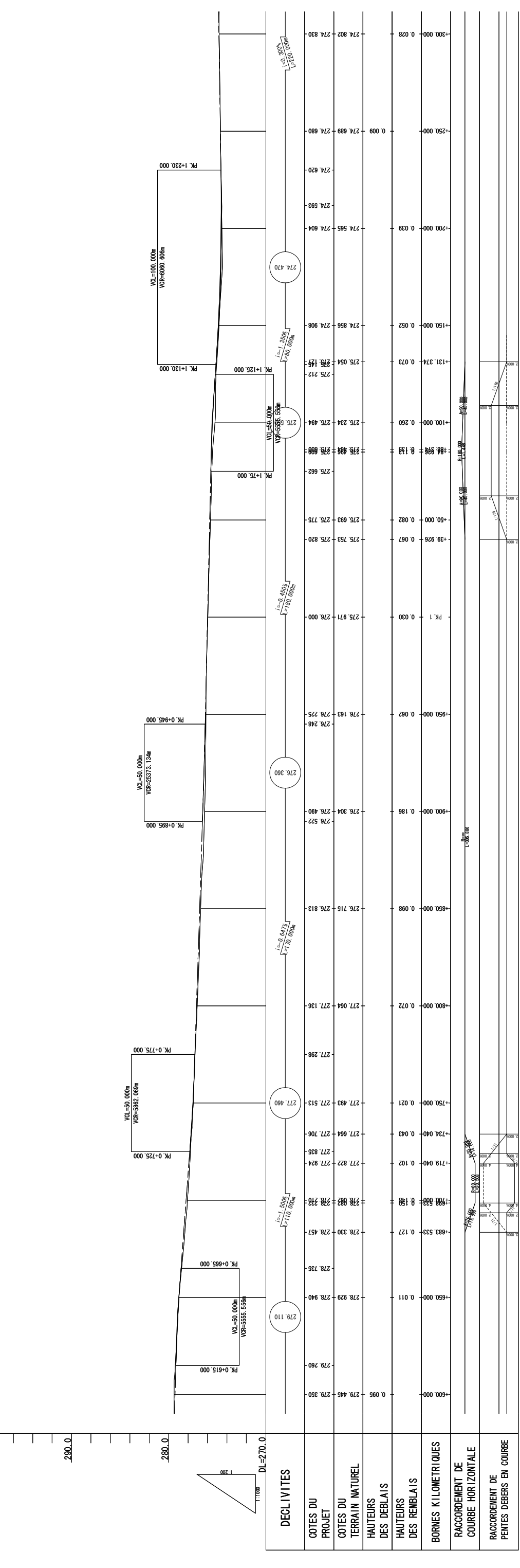
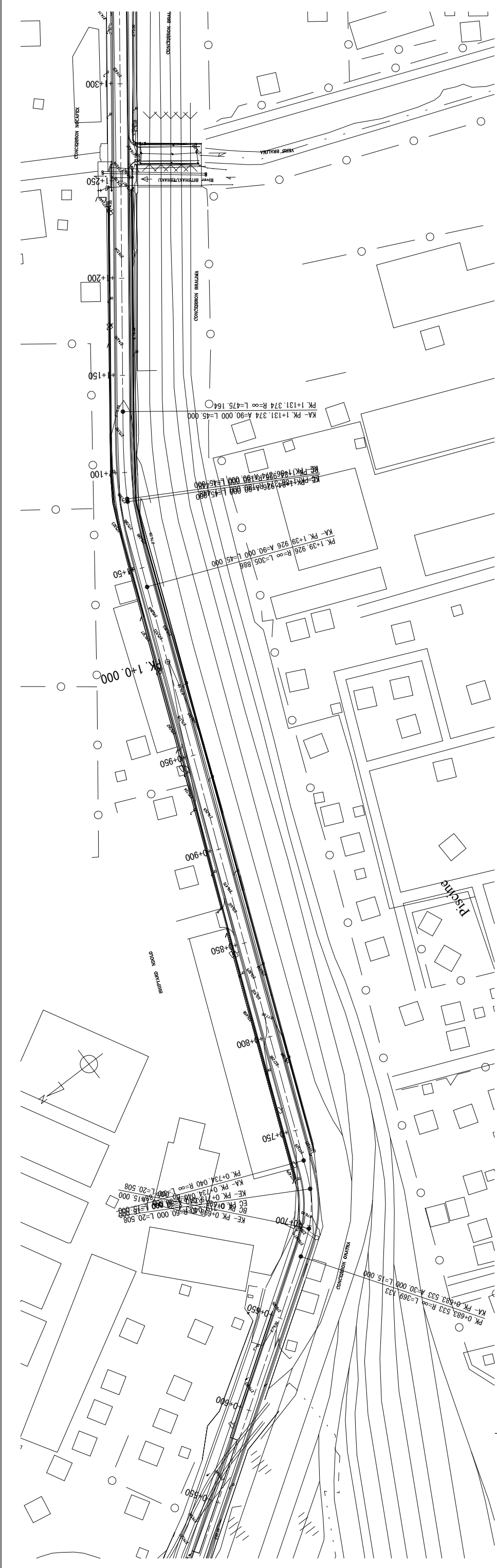

| DECLIVITES                             | 279.110 | 277.460 | 276.360 | 274.470 | 274.700 |
|--|---------|---------|---------|---------|---------|
| COTES DU PROJET                        | 279.110 | 277.460 | 276.360 | 274.470 | 274.700 |
| COTES DU TERRAIN NATUREL               | 278.882 | 277.835 | 276.522 | 275.212 | 274.620 |
| HAUTEURS DES DEBLAIS                   | 0.095   | 0.095   | 0.095   | 0.095   | 0.095   |
| HAUTEURS DES REMBLAIS                  | 0.011   | 0.011   | 0.011   | 0.011   | 0.011   |
| BORNES KILOMETRIQUES                   | 0.095   | 0.095   | 0.095   | 0.095   | 0.095   |
| RACCORDEMENT DE COURBE HORIZONTALE     | 0.011   | 0.011   | 0.011   | 0.011   | 0.011   |
| RACCORDEMENT DE PENTES DEBRS EN COURBE | 0.011   | 0.011   | 0.011   | 0.011   | 0.011   |

|  |                                  |   |                              |              |      |         |                          |
|--|----------------------------------|---|------------------------------|--------------|------|---------|--------------------------|
| AGENCE JAPONAISE DE COOPERATION INTERNATIONALE | REPUBLIQUE DEMOCRATIQUE DU CONGO | L'ETUDE PREPARATOIRE POUR LE PROJET DE REHABILITATION ET DE MODERNISATION DE L'AVENUE DES POIDS LOURDS A KINSHASA | INGEROSEC CORPORATION, JAPON | DATE:        | 2009 | N°      | CG-BD-D2                 |
|  |                                  |   |                              | PREPARE PAR: |      | ECHELLE | A1-1:1.000<br>A3-1:2.000 |

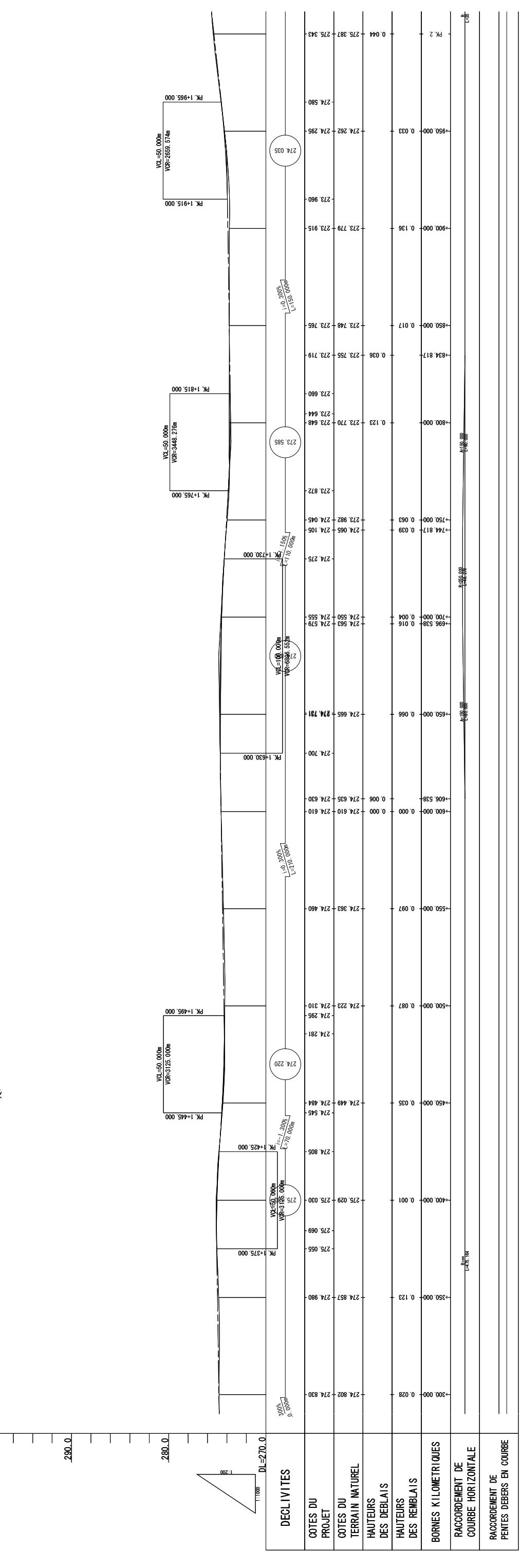

| DECLIVITES | COTES DU PROJET | COTES DU TERRAIN NATUREL | HAUTEURS DES DEBLAIS | HAUTEURS DES REMBLAIS | BORNES KILOMETRIQUES | RACCORDEMENT DE COURBE HORIZONTALE | RACCORDEMENT DE PENTES DEBRS EN COURBE | DATE: | PREPARE PAR: | VERIFIE PAR: | INGEROSEC CORPORATION, JAPON | PLAN ET PROFIL (3/18) |          |          | N° |
|------------|-----------------|--------------------------|----------------------|-----------------------|----------------------|------------------------------------|--|-------|--------------|--------------|------------------------------|-----------------------|----------|----------|----|
|            |                 |                          |                      |                       |                      |                                    |  |       |              |              |                              | PK.1+300              | PK.2+000 | CG-BD-D3 |    |
| 274.802    | 274.830         | 274.830                  | 0.028                | 0.028                 | 274.802              | 274.830                            | 274.830                                | 2009  | A1-1:1.000   | A3-1:2.000   |                              | 2009                  | CG-BD-D3 |          |    |
| 274.857    | 274.980         | 274.980                  | 0.123                | 0.123                 | 274.857              | 274.980                            | 274.980                                |       |              |              |                              |                       |          |          |    |
| 275.055    | 275.055         | 275.055                  | 0.001                | 0.001                 | 275.029              | 275.030                            | 275.055                                |       |              |              |                              |                       |          |          |    |
| 274.805    | 274.805         | 274.805                  | 0.035                | 0.035                 | 274.449              | 274.484                            | 274.805                                |       |              |              |                              |                       |          |          |    |
| 274.295    | 274.295         | 274.295                  | 0.087                | 0.087                 | 274.223              | 274.310                            | 274.295                                |       |              |              |                              |                       |          |          |    |
| 274.610    | 274.610         | 274.610                  | 0.000                | 0.000                 | 274.610              | 274.610                            | 274.610                                |       |              |              |                              |                       |          |          |    |
| 274.635    | 274.630         | 274.630                  | 0.006                | 0.006                 | 274.635              | 274.630                            | 274.630                                |       |              |              |                              |                       |          |          |    |
| 274.665    | 274.781         | 274.665                  | 0.068                | 0.068                 | 274.665              | 274.781                            | 274.665                                |       |              |              |                              |                       |          |          |    |
| 274.696    | 274.579         | 274.696                  | 0.016                | 0.016                 | 274.696              | 274.579                            | 274.696                                |       |              |              |                              |                       |          |          |    |
| 274.700    | 274.700         | 274.700                  | 0.000                | 0.000                 | 274.700              | 274.700                            | 274.700                                |       |              |              |                              |                       |          |          |    |
| 274.982    | 274.105         | 274.982                  | 0.083                | 0.083                 | 274.982              | 274.105                            | 274.982                                |       |              |              |                              |                       |          |          |    |
| 273.922    | 274.045         | 273.922                  | 0.063                | 0.063                 | 273.922              | 274.045                            | 273.922                                |       |              |              |                              |                       |          |          |    |
| 273.779    | 273.915         | 273.779                  | 0.138                | 0.138                 | 273.779              | 273.915                            | 273.779                                |       |              |              |                              |                       |          |          |    |
| 273.748    | 273.765         | 273.748                  | 0.017                | 0.017                 | 273.748              | 273.765                            | 273.748                                |       |              |              |                              |                       |          |          |    |
| 273.834    | 273.719         | 273.834                  | 0.036                | 0.036                 | 273.834              | 273.719                            | 273.834                                |       |              |              |                              |                       |          |          |    |
| 273.660    | 273.644         | 273.660                  | 0.0123               | 0.0123                | 273.660              | 273.644                            | 273.660                                |       |              |              |                              |                       |          |          |    |
| 273.717    | 273.648         | 273.717                  | 0.063                | 0.063                 | 273.717              | 273.648                            | 273.717                                |       |              |              |                              |                       |          |          |    |
| 274.000    | 273.915         | 274.000                  | 0.085                | 0.085                 | 274.000              | 273.915                            | 274.000                                |       |              |              |                              |                       |          |          |    |
| 274.035    | 273.960         | 274.035                  | 0.075                | 0.075                 | 274.035              | 273.960                            | 274.035                                |       |              |              |                              |                       |          |          |    |
| 275.387    | 275.343         | 275.387                  | 0.044                | 0.044                 | 275.387              | 275.343                            | 275.387                                |       |              |              |                              |                       |          |          |    |



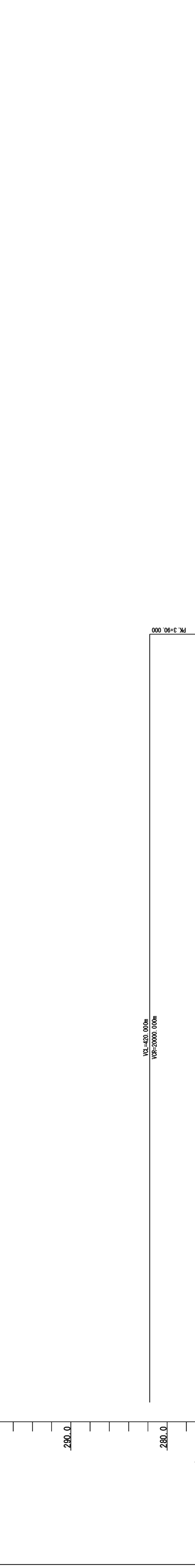

| DECLIVITES                            | L1=1000.000m<br>L=120.000m |         | L1=1000.000m<br>L=120.000m |         | L1=1000.000m<br>L=120.000m |         | L1=1000.000m<br>L=120.000m |         | L1=1000.000m<br>L=120.000m |         | L1=1000.000m<br>L=120.000m |         | L1=1000.000m<br>L=120.000m |         | L1=1000.000m<br>L=120.000m |         | L1=1000.000m<br>L=120.000m |         |
|---------------------------------------|----------------------------|---------|----------------------------|---------|----------------------------|---------|----------------------------|---------|----------------------------|---------|----------------------------|---------|----------------------------|---------|----------------------------|---------|----------------------------|---------|
|                                       | PK                         | E       | PK                         | E       | PK                         | E       | PK                         | E       | PK                         | E       | PK                         | E       | PK                         | E       | PK                         | E       | PK                         | E       |
| COTES DU PROJET                       | 275.89                     | 276.26  | 275.89                     | 276.26  | 275.89                     | 276.26  | 275.89                     | 276.26  | 275.89                     | 276.26  | 275.89                     | 276.26  | 275.89                     | 276.26  | 275.89                     | 276.26  | 275.89                     | 276.26  |
| COTES DU TERRAIN NATUREL              | 275.594                    | 275.594 | 275.594                    | 275.594 | 275.594                    | 275.594 | 275.594                    | 275.594 | 275.594                    | 275.594 | 275.594                    | 275.594 | 275.594                    | 275.594 | 275.594                    | 275.594 | 275.594                    | 275.594 |
| HAUTEURS DES DEBLAIS                  | 0.081                      | 0.081   | 0.081                      | 0.081   | 0.081                      | 0.081   | 0.081                      | 0.081   | 0.081                      | 0.081   | 0.081                      | 0.081   | 0.081                      | 0.081   | 0.081                      | 0.081   | 0.081                      | 0.081   |
| HAUTEURS DES REMBLAIS                 | 0.052                      | 0.052   | 0.052                      | 0.052   | 0.052                      | 0.052   | 0.052                      | 0.052   | 0.052                      | 0.052   | 0.052                      | 0.052   | 0.052                      | 0.052   | 0.052                      | 0.052   | 0.052                      | 0.052   |
| BORNES KILOMETRIQUES                  | 275.594                    | 275.594 | 275.594                    | 275.594 | 275.594                    | 275.594 | 275.594                    | 275.594 | 275.594                    | 275.594 | 275.594                    | 275.594 | 275.594                    | 275.594 | 275.594                    | 275.594 | 275.594                    | 275.594 |
| RACCORDMENT DE COURBE HORIZONTALE     | 0.031                      | 0.031   | 0.031                      | 0.031   | 0.031                      | 0.031   | 0.031                      | 0.031   | 0.031                      | 0.031   | 0.031                      | 0.031   | 0.031                      | 0.031   | 0.031                      | 0.031   | 0.031                      | 0.031   |
| RACCORDMENT DE PENTES DEBRS EN COURBE | 0.059                      | 0.059   | 0.059                      | 0.059   | 0.059                      | 0.059   | 0.059                      | 0.059   | 0.059                      | 0.059   | 0.059                      | 0.059   | 0.059                      | 0.059   | 0.059                      | 0.059   | 0.059                      | 0.059   |

|  |                                  |   |  |                              |                                       |  |                                     |              |                |
|--|----------------------------------|---|--|------------------------------|---------------------------------------|--|-------------------------------------|--------------|----------------|
| AGENCE JAPONAISE DE COOPERATION INTERNATIONALE | REPUBLIQUE DEMOCRATIQUE DU CONGO | L'ETUDE PREPARATOIRE POUR LE PROJET DE REHABILITATION ET DE MODERNISATION DE L'AVENUE DES POIDS LOURDS A KINSHASA |  | INGEROSEC CORPORATION, JAPON | DATE:<br>PREPARE PAR:<br>VERIFIE PAR: | PLAN ET PROFIL (5/18)<br>PK.2+700 - PK.3+400 | ECHELLE<br>A1-1:1.000<br>A3-1:2.000 | DATE<br>2009 | N°<br>CG-BD-D5 |
|--|----------------------------------|---|--|------------------------------|---------------------------------------|--|-------------------------------------|--------------|----------------|

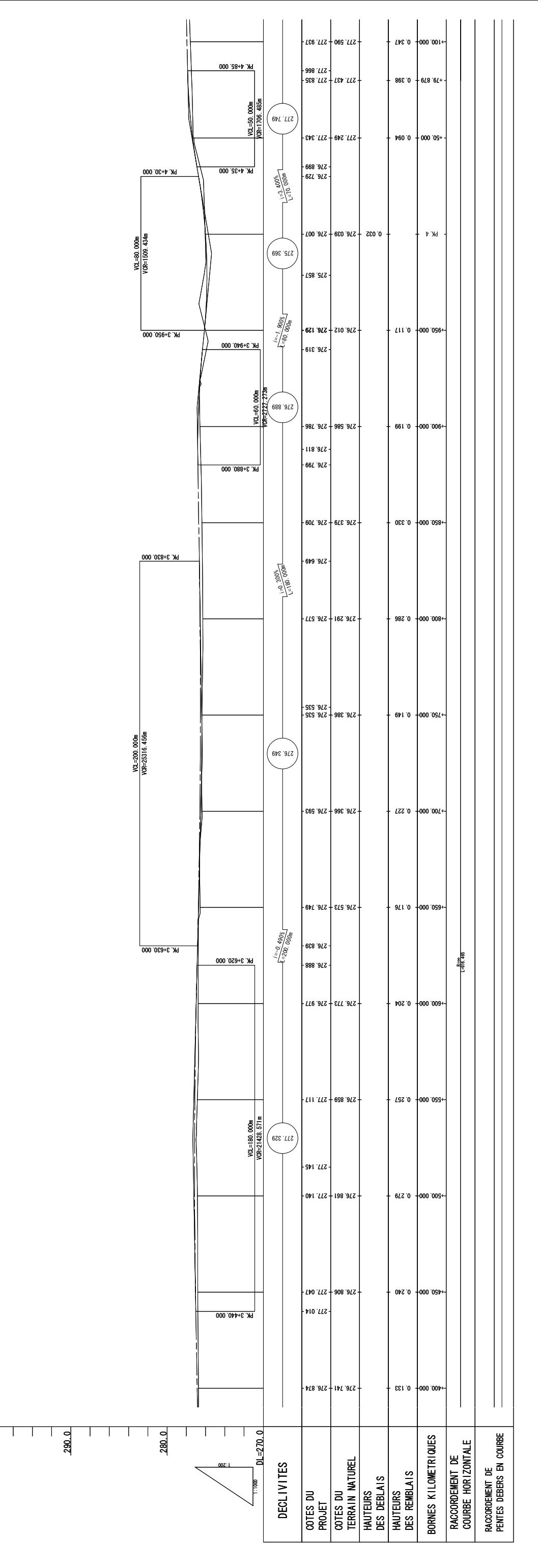
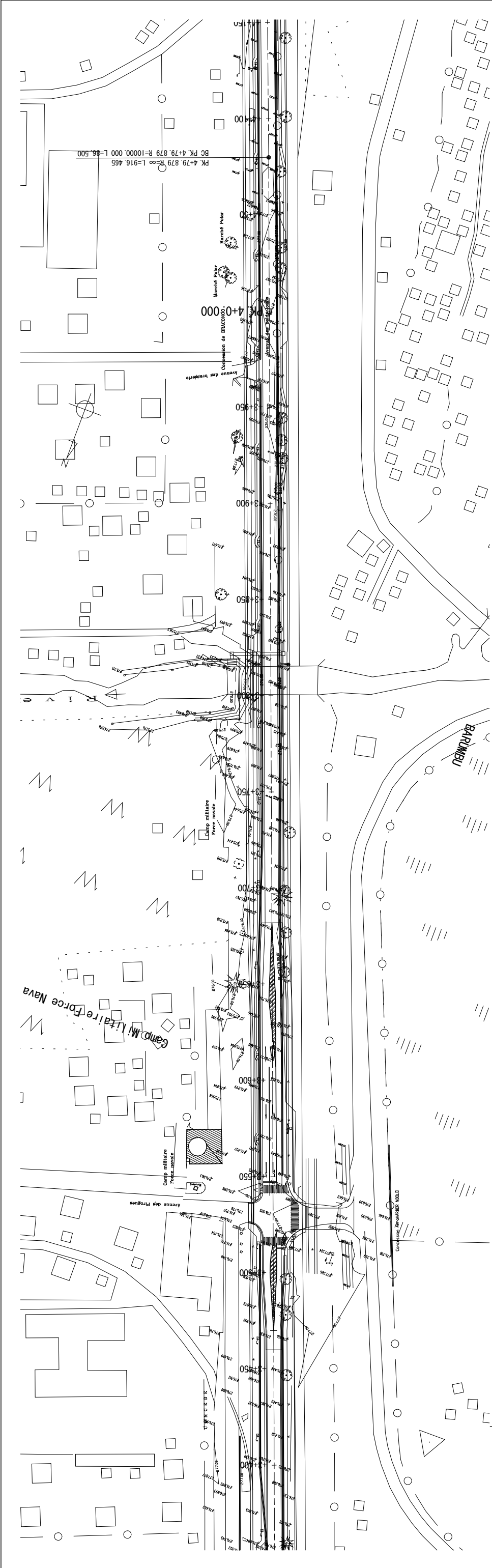

|  |                                  |   |                              |                              |                       |         |      |    |
|--|----------------------------------|---|------------------------------|------------------------------|-----------------------|---------|------|----|
| AGENCE JAPONAISE DE COOPERATION INTERNATIONALE | REPUBLIQUE DEMOCRATIQUE DU CONGO | L'ETUDE PREPARATOIRE POUR LE PROJET DE REHABILITATION ET DE MODERNISATION DE L'AVENUE DES POIDS LOURDS A KINSHASA | INGEROSEC CORPORATION, JAPON | DATE:                        | PLAN ET PROFIL (6/18) | ECHELLE | DATE | N° |
|  |                                  |   |                              | PREPARE PAR:<br>VERIFIE PAR: | PK.3+400 - PK.4+100   |         |      |    |

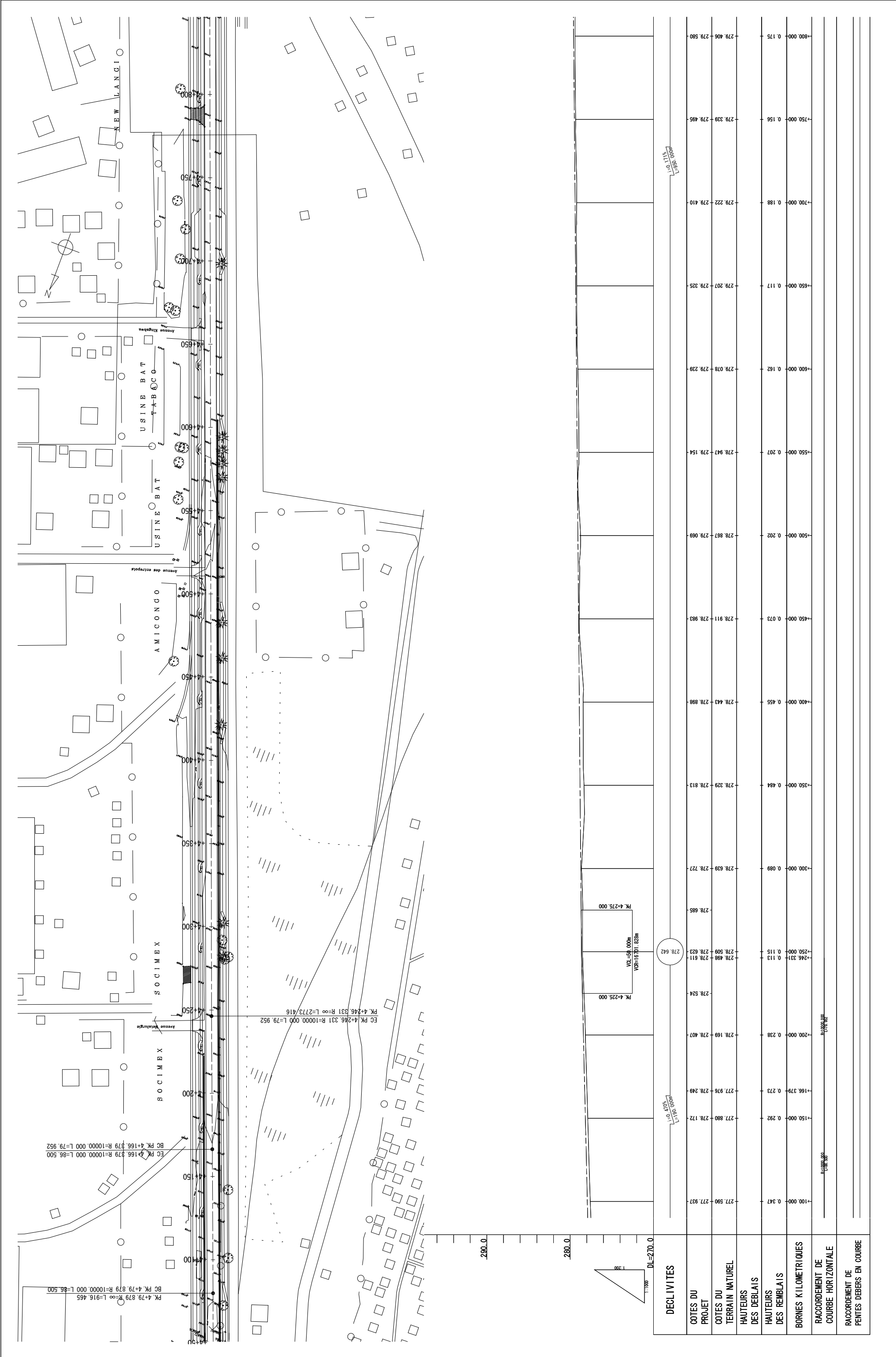

| DECLIVITES                            | 277.590 | 277.937 | 277.880 | 278.172 | 277.976 | 278.249 | 278.169 | 278.407 | 278.524 | 278.498 | 278.611 | 278.509 | 278.623 | 278.642 | 278.639 | 278.727 | 278.329 | 278.813 | 278.443 | 278.898 | 278.887 | 279.069 | 278.947 | 279.154 | 278.078 | 279.239 | 279.207 | 279.325 | 279.222 | 279.410 | 279.339 | 279.495 | 279.406 | 279.580 |       |       |
|---------------------------------------|---------|---------|---------|---------|---------|---------|---------|---------|---------|---------|---------|---------|---------|---------|---------|---------|---------|---------|---------|---------|---------|---------|---------|---------|---------|---------|---------|---------|---------|---------|---------|---------|---------|---------|-------|-------|
| COTES DU PROJET                       | 0.347   | 0.292   | 0.273   | 0.089   | 0.484   | 0.455   | 0.073   | 0.202   | 0.207   | 0.162   | 0.117   | 0.188   | 0.156   | 0.117   | 0.117   | 0.117   | 0.117   | 0.117   | 0.117   | 0.117   | 0.117   | 0.117   | 0.117   | 0.117   | 0.117   | 0.117   | 0.117   | 0.117   | 0.117   | 0.117   | 0.117   | 0.117   | 0.117   | 0.117   | 0.117 |       |
| COTES DU TERRAIN NATUREL              | 0.347   | 0.292   | 0.273   | 0.089   | 0.484   | 0.455   | 0.073   | 0.202   | 0.207   | 0.162   | 0.117   | 0.188   | 0.156   | 0.117   | 0.117   | 0.117   | 0.117   | 0.117   | 0.117   | 0.117   | 0.117   | 0.117   | 0.117   | 0.117   | 0.117   | 0.117   | 0.117   | 0.117   | 0.117   | 0.117   | 0.117   | 0.117   | 0.117   | 0.117   | 0.117 | 0.117 |
| HAUTEURS DES DEBLAIS                  | 0.347   | 0.292   | 0.273   | 0.089   | 0.484   | 0.455   | 0.073   | 0.202   | 0.207   | 0.162   | 0.117   | 0.188   | 0.156   | 0.117   | 0.117   | 0.117   | 0.117   | 0.117   | 0.117   | 0.117   | 0.117   | 0.117   | 0.117   | 0.117   | 0.117   | 0.117   | 0.117   | 0.117   | 0.117   | 0.117   | 0.117   | 0.117   | 0.117   | 0.117   | 0.117 | 0.117 |
| HAUTEURS DES REMBLAIS                 | 0.347   | 0.292   | 0.273   | 0.089   | 0.484   | 0.455   | 0.073   | 0.202   | 0.207   | 0.162   | 0.117   | 0.188   | 0.156   | 0.117   | 0.117   | 0.117   | 0.117   | 0.117   | 0.117   | 0.117   | 0.117   | 0.117   | 0.117   | 0.117   | 0.117   | 0.117   | 0.117   | 0.117   | 0.117   | 0.117   | 0.117   | 0.117   | 0.117   | 0.117   | 0.117 | 0.117 |
| BORNES KILOMETRIQUES                  | 0.347   | 0.292   | 0.273   | 0.089   | 0.484   | 0.455   | 0.073   | 0.202   | 0.207   | 0.162   | 0.117   | 0.188   | 0.156   | 0.117   | 0.117   | 0.117   | 0.117   | 0.117   | 0.117   | 0.117   | 0.117   | 0.117   | 0.117   | 0.117   | 0.117   | 0.117   | 0.117   | 0.117   | 0.117   | 0.117   | 0.117   | 0.117   | 0.117   | 0.117   | 0.117 | 0.117 |
| RACCORDMENT DE COURBE HORIZONTALE     | 0.347   | 0.292   | 0.273   | 0.089   | 0.484   | 0.455   | 0.073   | 0.202   | 0.207   | 0.162   | 0.117   | 0.188   | 0.156   | 0.117   | 0.117   | 0.117   | 0.117   | 0.117   | 0.117   | 0.117   | 0.117   | 0.117   | 0.117   | 0.117   | 0.117   | 0.117   | 0.117   | 0.117   | 0.117   | 0.117   | 0.117   | 0.117   | 0.117   | 0.117   | 0.117 | 0.117 |
| RACCORDMENT DE PENTES DEBRS EN COURBE | 0.347   | 0.292   | 0.273   | 0.089   | 0.484   | 0.455   | 0.073   | 0.202   | 0.207   | 0.162   | 0.117   | 0.188   | 0.156   | 0.117   | 0.117   | 0.117   | 0.117   | 0.117   | 0.117   | 0.117   | 0.117   | 0.117   | 0.117   | 0.117   | 0.117   | 0.117   | 0.117   | 0.117   | 0.117   | 0.117   | 0.117   | 0.117   | 0.117   | 0.117   | 0.117 | 0.117 |

|  |                                  |   |                              |              |      |         |                          |    |          |
|--|----------------------------------|---|------------------------------|--------------|------|---------|--------------------------|----|----------|
| AGENCE JAPONAISE DE COOPERATION INTERNATIONALE | REPUBLIQUE DEMOCRATIQUE DU CONGO | L'ETUDE PREPARATOIRE POUR LE PROJET DE REHABILITATION ET DE MODERNISATION DE L'AVENUE DES POIDS LOURDS A KINSHASA | INGEROSEC CORPORATION, JAPON | DATE:        | 2009 | DATE    | 2009                     | N° | CG-BD-D7 |
|  |                                  |   |                              | PREPARE PAR: |      | ECHELLE | A1-1:1,000<br>A3-1:2,000 |    |          |

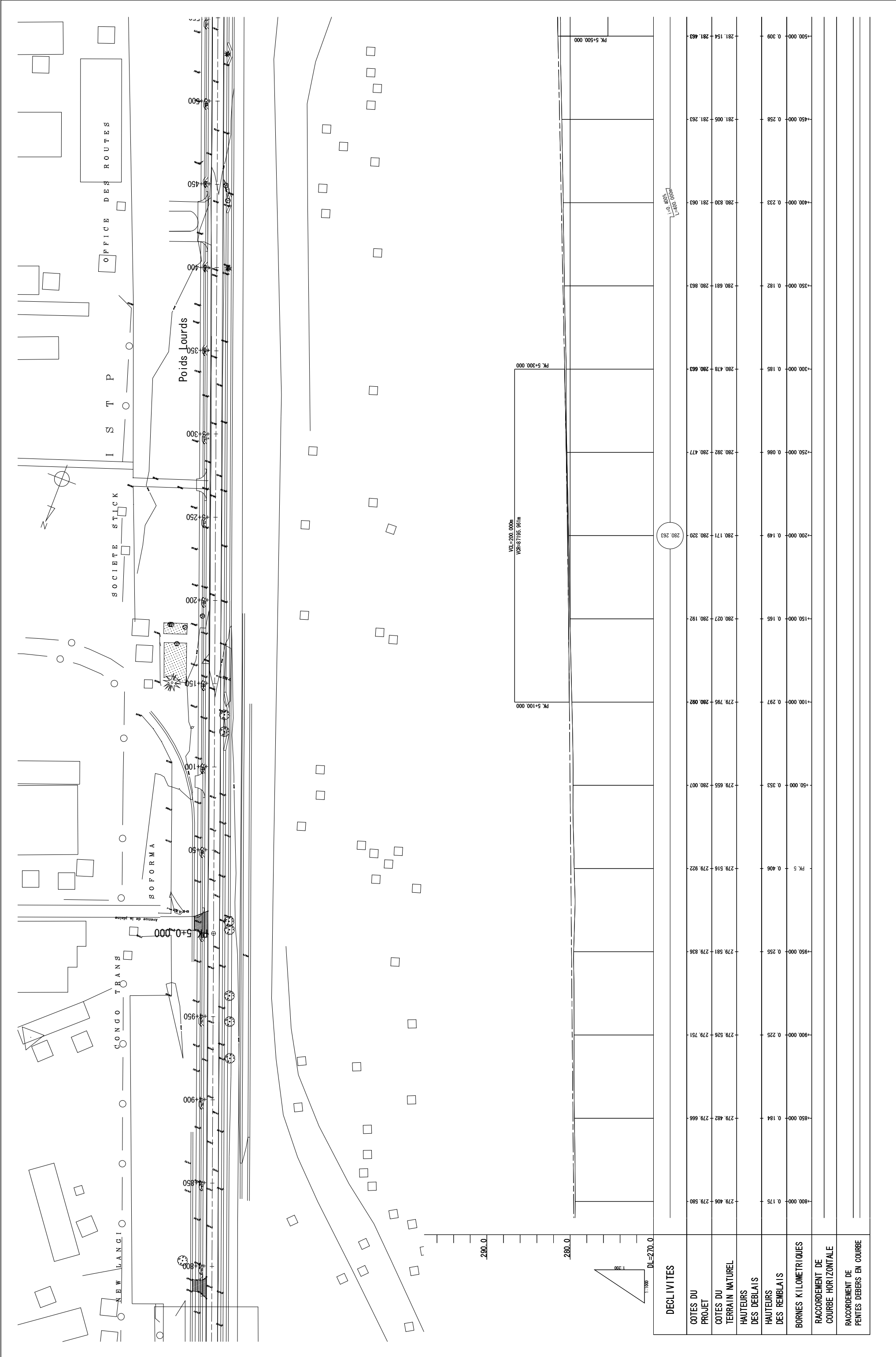

|  |                                  |   |                              |              |                       |         |      |    |
|--|----------------------------------|---|------------------------------|--------------|-----------------------|---------|------|----|
| AGENCE JAPONAISE DE COOPERATION INTERNATIONALE | REPUBLIQUE DEMOCRATIQUE DU CONGO | L'ETUDE PREPARATOIRE POUR LE PROJET DE REHABILITATION ET DE MODERNISATION DE L'AVENUE DES POIDS LOURDS A KINSHASA | INGEROSEC CORPORATION, JAPON | DATE:        | PLAN ET PROFIL (8/18) | ECHELLE | DATE | N° |
|  |                                  |   |                              | PREPARE PAR: | PK.4+800 - PK.5+500   |         |      |    |
|  |                                  |   |                              | VERIFIE PAR: |                       |         |      |    |

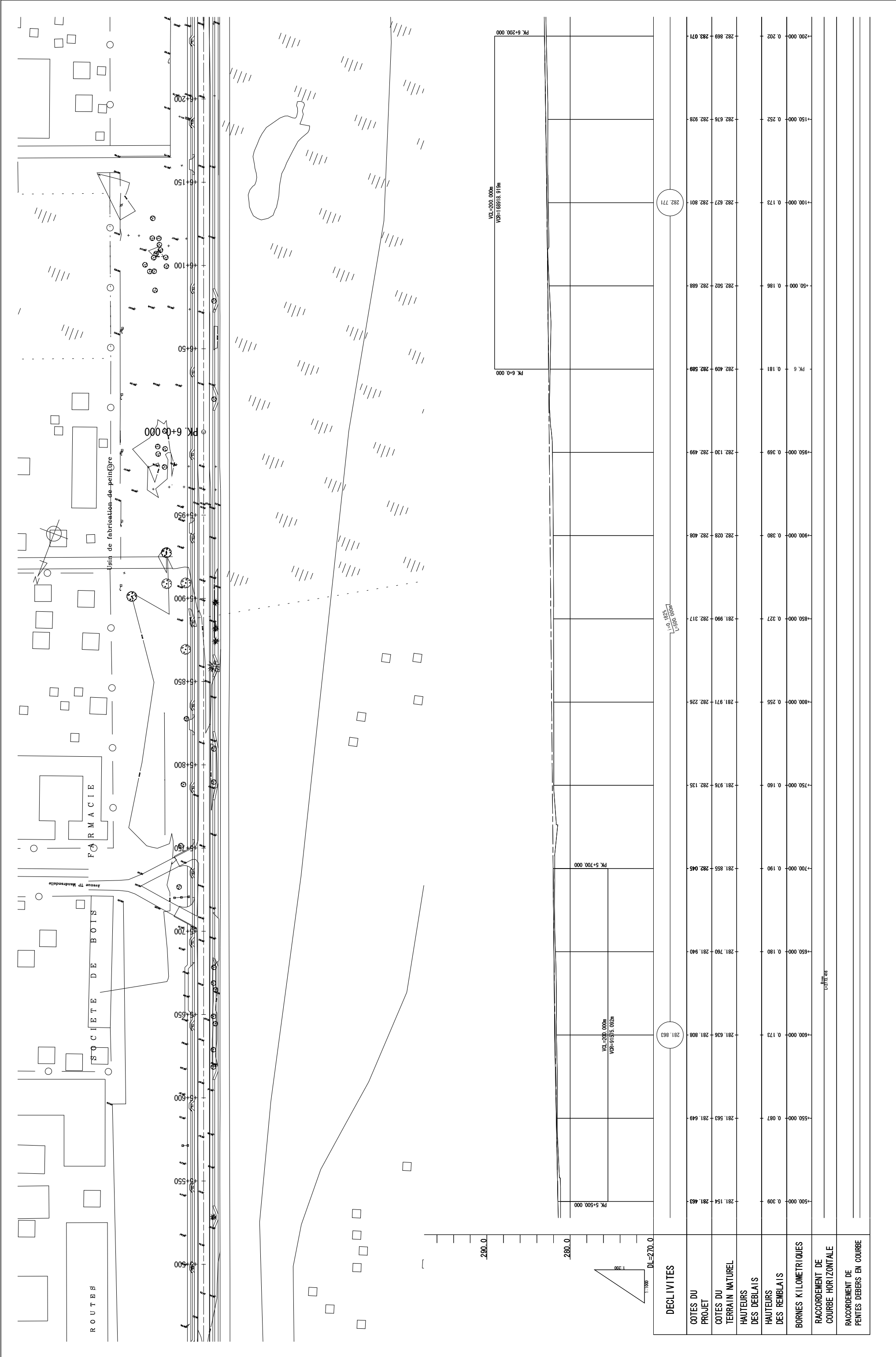

| DECLIVITES                             | 281.863           |                   | 281.990 - 282.317 |                   | 282.028 - 282.408 |                   | 282.130 - 282.499 |                   | 282.409 - 282.589 |                   | 282.502 - 282.688 |                   | 282.627 - 282.801 |                   | 282.676 - 282.928 |       | 282.869 - 283.071 |  |
|--|-------------------|-------------------|-------------------|-------------------|-------------------|-------------------|-------------------|-------------------|-------------------|-------------------|-------------------|-------------------|-------------------|-------------------|-------------------|-------|-------------------|--|
|  | 0.309             | 0.087             | 0.173             | 0.180             | 0.190             | 0.160             | 0.327             | 0.255             | 0.280             | 0.389             | 0.181             | 0.186             | 0.173             | 0.252             | 0.202             | 0.000 | 0.000             |  |
| COTES DU PROJET                        | 281.154 - 281.463 | 281.563 - 281.649 | 281.636 - 281.808 | 281.760 - 281.940 | 281.855 - 282.045 | 281.976 - 282.135 | 281.990 - 282.317 | 282.028 - 282.408 | 282.130 - 282.499 | 282.409 - 282.589 | 282.502 - 282.688 | 282.627 - 282.801 | 282.676 - 282.928 | 282.869 - 283.071 |                   |       |                   |  |
| COTES DU TERRAIN NATUREL               |                   |                   |                   |                   |                   |                   |                   |                   |                   |                   |                   |                   |                   |                   |                   |       |                   |  |
| HAUTEURS DES DEBLAIS                   |                   |                   |                   |                   |                   |                   |                   |                   |                   |                   |                   |                   |                   |                   |                   |       |                   |  |
| HAUTEURS DES REMBLAIS                  |                   |                   |                   |                   |                   |                   |                   |                   |                   |                   |                   |                   |                   |                   |                   |       |                   |  |
| BORNES KILOMETRIQUES                   |                   |                   |                   |                   |                   |                   |                   |                   |                   |                   |                   |                   |                   |                   |                   |       |                   |  |
| RACCORDEMENT DE COURBE HORIZONTALE     |                   |                   |                   |                   |                   |                   |                   |                   |                   |                   |                   |                   |                   |                   |                   |       |                   |  |
| RACCORDEMENT DE PENTES DEBRS EN COURBE |                   |                   |                   |                   |                   |                   |                   |                   |                   |                   |                   |                   |                   |                   |                   |       |                   |  |

|  |                                  |   |                              |              |                       |         |      |    |
|--|----------------------------------|---|------------------------------|--------------|-----------------------|---------|------|----|
| AGENCE JAPONAISE DE COOPERATION INTERNATIONALE | REPUBLIQUE DEMOCRATIQUE DU CONGO | L'ETUDE PREPARATOIRE POUR LE PROJET DE REHABILITATION ET DE MODERNISATION DE L'AVENUE DES POIDS LOURDS A KINSHASA | INGEROSEC CORPORATION, JAPON | DATE:        | PLAN ET PROFIL (9/18) | ECHELLE | DATE | N° |
|  |                                  |   |                              | PREPARE PAR: | PK.5+500 - PK.6+200   |         |      |    |
|  |                                  |   |                              | VERIFIE PAR: |                       |         |      |    |



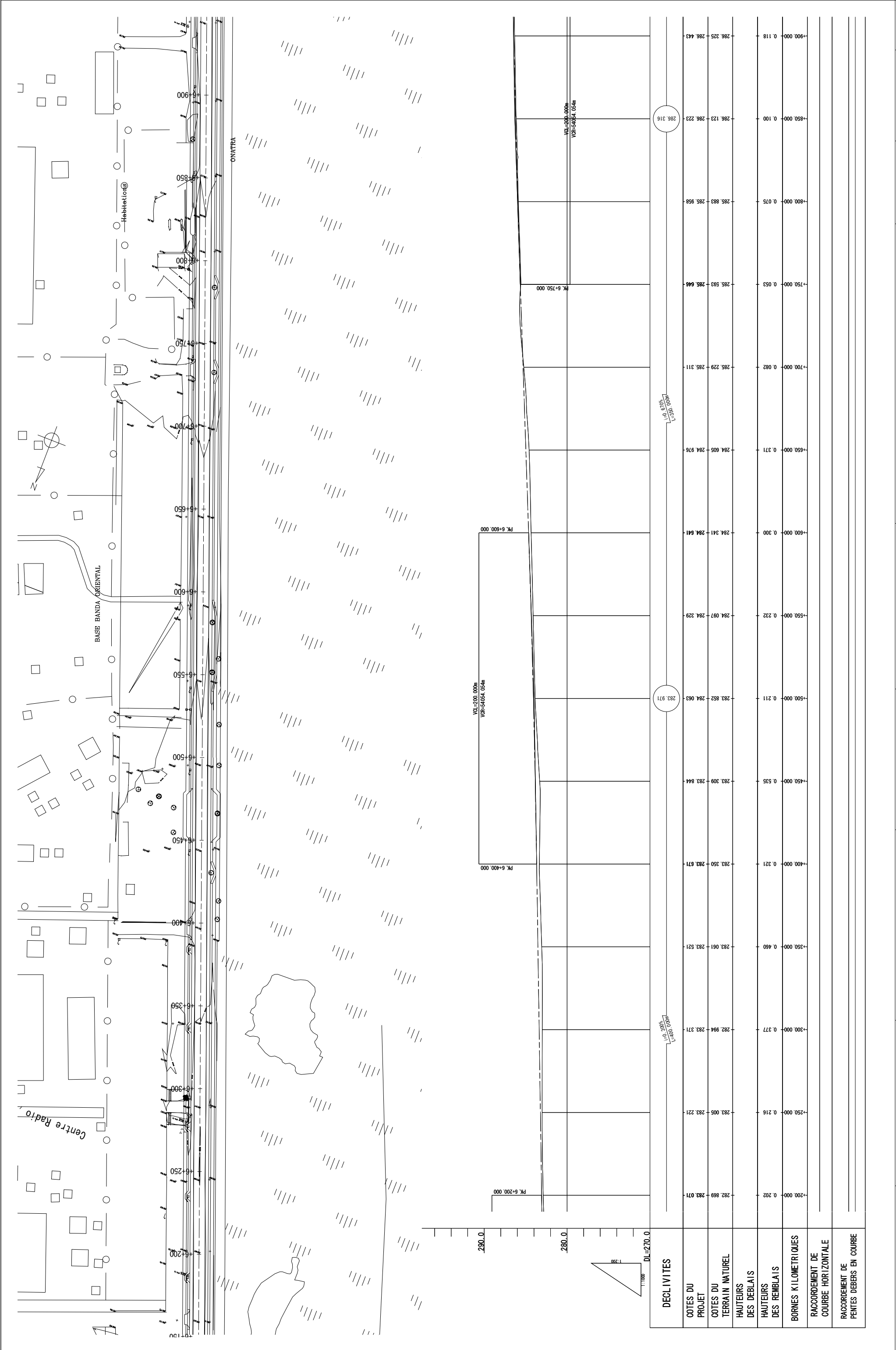

| DECLIVITES                             | 283.971 |         | 286.316 |         |
|--|---------|---------|---------|---------|
| COTES DU PROJET                        | 282.869 | 283.071 | 283.005 | 283.221 |
| COTES DU TERRAIN NATUREL               | 282.994 | 283.371 | 283.061 | 283.521 |
| HAUTEURS DES DEBLAIS                   |         |         | 283.309 | 283.844 |
| HAUTEURS DES REMBLAIS                  |         |         | 283.852 | 284.063 |
| BORNES KILOMETRIQUES                   |         |         | 283.950 | 283.671 |
| RACCORDEMENT DE COURBE HORIZONTALE     |         |         | 284.097 | 284.329 |
| RACCORDEMENT DE PENTES DEBRS EN COURBE |         |         | 284.341 | 284.641 |
|  |         |         | 284.605 | 284.976 |
|  |         |         | 285.229 | 285.311 |
|  |         |         | 285.593 | 285.646 |
|  |         |         | 285.883 | 285.958 |
|  |         |         | 286.123 | 286.223 |
|  |         |         | 286.325 | 286.443 |

|  |                                  |   |  |                              |                                       |   |  |                                     |              |                 |
|--|----------------------------------|---|--|------------------------------|---------------------------------------|---|--|-------------------------------------|--------------|-----------------|
| AGENCE JAPONAISE DE COOPERATION INTERNATIONALE | REPUBLIQUE DEMOCRATIQUE DU CONGO | L'ETUDE PREPARATOIRE POUR LE PROJET DE REHABILITATION ET DE MODERNISATION DE L'AVENUE DES POIDS LOURDS A KINSHASA |  | INGEROSEC CORPORATION, JAPON | DATE:<br>PREPARE PAR:<br>VERIFIE PAR: | PLAN ET PROFIL (10/18)<br>PK.6+200 - PK.6+900 |  | ECHELLE<br>A1-1:1.000<br>A3-1:2.000 | DATE<br>2009 | N°<br>CG-BD-D10 |
|  |                                  |   |  |                              |                                       |   |  |                                     |              |                 |



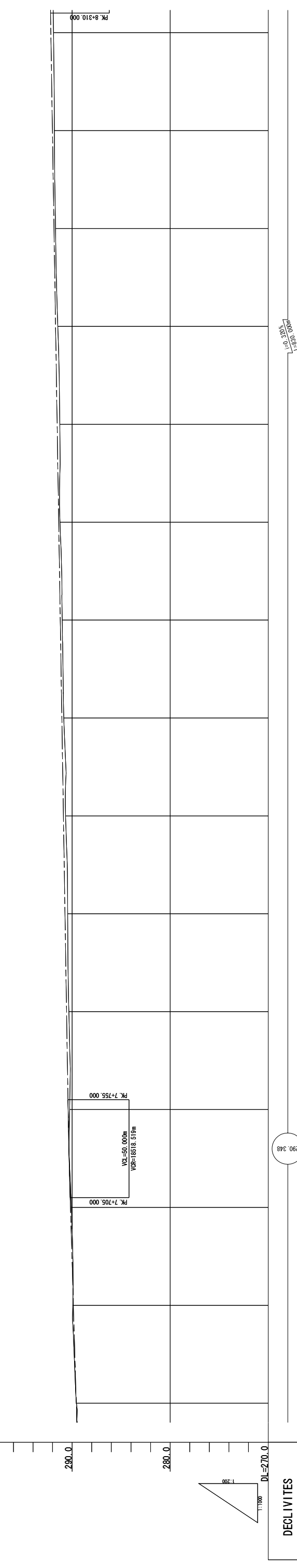
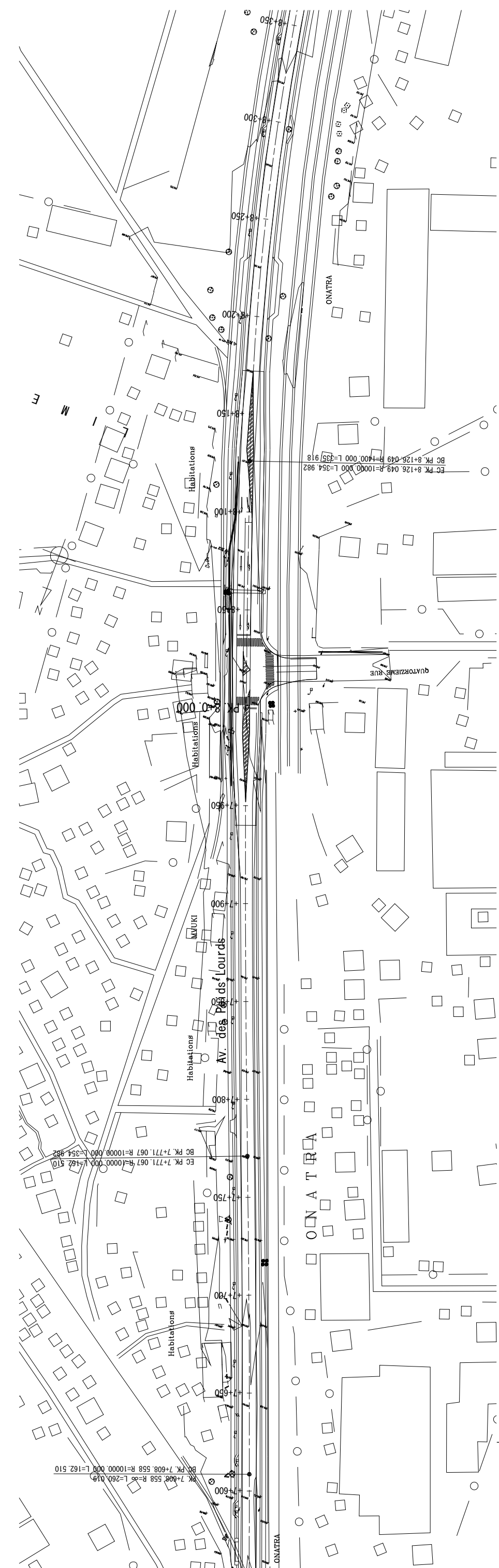

| DECLIVITES | COTES DU PROJET |         | COTES DU TERRAIN NATUREL |         | HAUTEURS DES DEBLAIS | HAUTEURS DES REMBLAIS | BORNES KILOMETRIQUES | RACCORDEMENT DE COURBE HORIZONTALE | RACCORDEMENT DE PENTES DEBRS EN COURBE |
|------------|-----------------|---------|--------------------------|---------|----------------------|-----------------------|----------------------|------------------------------------|--|
|            | PK              | E       | PK                       | E       |                      |                       |                      |                                    |  |
|            | 290.090         | 290.171 | 290.090                  | 290.171 | 0.081                | 0.081                 | 290.090              | 290.171                            |  |
|            | 290.197         | 290.479 | 290.197                  | 290.479 | 0.283                | 0.283                 | 290.197              | 290.479                            |  |
|            | 290.331         | 290.572 | 290.331                  | 290.572 | 0.241                | 0.241                 | 290.331              | 290.572                            |  |
|            | 290.456         | 290.732 | 290.456                  | 290.732 | 0.276                | 0.276                 | 290.456              | 290.732                            |  |
|            | 290.649         | 291.052 | 290.649                  | 291.052 | 0.203                | 0.203                 | 290.649              | 291.052                            |  |
|            | 291.010         | 291.212 | 291.010                  | 291.212 | 0.202                | 0.202                 | 291.010              | 291.212                            |  |
|            | 291.239         | 291.372 | 291.239                  | 291.372 | 0.133                | 0.133                 | 291.239              | 291.372                            |  |
|            | 291.268         | 291.532 | 291.268                  | 291.532 | 0.264                | 0.264                 | 291.268              | 291.532                            |  |
|            | 291.323         | 291.615 | 291.323                  | 291.615 | 0.292                | 0.292                 | 291.323              | 291.615                            |  |
|            | 291.468         | 291.692 | 291.468                  | 291.692 | 0.224                | 0.224                 | 291.468              | 291.692                            |  |
|            | 291.693         | 291.852 | 291.693                  | 291.852 | 0.159                | 0.159                 | 291.693              | 291.852                            |  |
|            | 291.808         | 292.012 | 291.808                  | 292.012 | 0.204                | 0.204                 | 291.808              | 292.012                            |  |
|            | 291.909         | 292.172 | 291.909                  | 292.172 | 0.263                | 0.263                 | 291.909              | 292.172                            |  |
|            | 291.000         | 292.000 | 291.000                  | 292.000 | 0.263                | 0.263                 | 291.000              | 292.000                            |  |

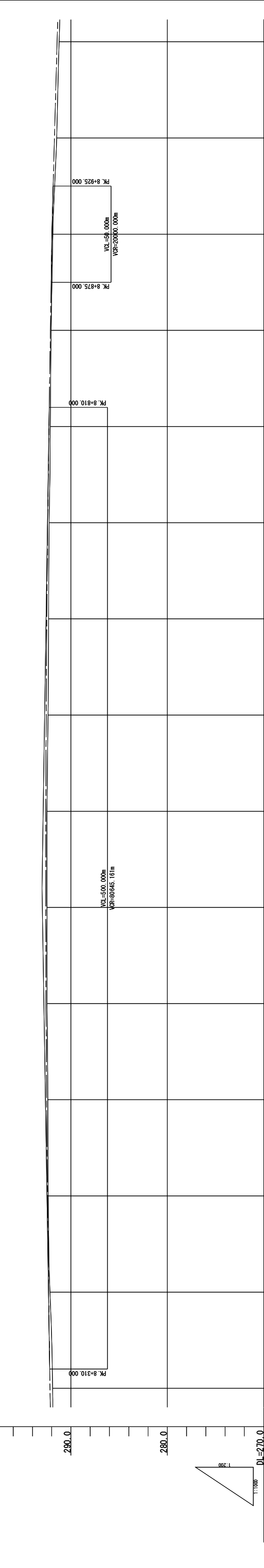

| DECLIVITES                             | 291.984  | 291.846  | 291.968  | 292.059  | 292.134  | 292.186  | 292.254  | 292.283  | 292.251  | 292.412  | 292.308  | 292.482  | 292.319  | 292.509  | 292.387  | 292.575  | 292.486  | 292.611  | 292.617  | 292.486  | 292.615  | 292.478  | 292.588  | 292.415  | 292.547  | 292.402  | 292.530  | 292.354  | 292.442  | 292.175  | 292.322  | 292.204  | 291.909  | 292.172  |  |  |
|--|----------|----------|----------|----------|----------|----------|----------|----------|----------|----------|----------|----------|----------|----------|----------|----------|----------|----------|----------|----------|----------|----------|----------|----------|----------|----------|----------|----------|----------|----------|----------|----------|----------|----------|--|--|
| COTES DU PROJET                        | -291.223 | -291.476 | -291.709 | -291.880 | -291.968 | -292.052 | -292.134 | -292.092 | -292.186 | -292.052 | -292.134 | -292.308 | -292.482 | -292.319 | -292.509 | -292.387 | -292.575 | -292.486 | -292.611 | -292.486 | -292.615 | -292.478 | -292.588 | -292.415 | -292.547 | -292.402 | -292.530 | -292.354 | -292.442 | -292.175 | -292.322 | -292.204 | -291.909 | -292.172 |  |  |
| COTES DU TERRAIN NATUREL               | 0.211    | 0.233    | 0.233    | 0.088    | 0.088    | 0.082    | 0.093    | 0.142    | 0.161    | 0.173    | 0.190    | 0.173    | 0.190    | 0.125    | 0.188    | 0.125    | 0.125    | 0.125    | 0.125    | 0.129    | 0.129    | 0.110    | 0.132    | 0.128    | 0.128    | 0.088    | 0.088    | 0.147    | 0.147    | 0.263    | 0.263    | 0.263    | 0.263    | 0.263    |  |  |
| HAUTEURS DES DEBLAIS                   |          |          |          |          |          |          |          |          |          |          |          |          |          |          |          |          |          |          |          |          |          |          |          |          |          |          |          |          |          |          |          |          |          |          |  |  |
| HAUTEURS DES REMBLAIS                  |          |          |          |          |          |          |          |          |          |          |          |          |          |          |          |          |          |          |          |          |          |          |          |          |          |          |          |          |          |          |          |          |          |          |  |  |
| BORNES KILOMETRIQUES                   | PK 9     |          |          |          |          |          |          |          |          |          |          |          |          |          |          |          |          |          |          |          |          |          |          |          |          |          |          |          |          |          |          |          |          |          |  |  |
| RACCORDEMENT DE COURBE HORIZONTALE     |          |          |          |          |          |          |          |          |          |          |          |          |          |          |          |          |          |          |          |          |          |          |          |          |          |          |          |          |          |          |          |          |          |          |  |  |
| RACCORDEMENT DE PENTES DEBRS EN COURBE |          |          |          |          |          |          |          |          |          |          |          |          |          |          |          |          |          |          |          |          |          |          |          |          |          |          |          |          |          |          |          |          |          |          |  |  |

|  |                                  |   |                              |              |       |    |
|--|----------------------------------|---|------------------------------|--------------|-------|----|
| AGENCE JAPONAISE DE COOPERATION INTERNATIONALE | REPUBLIQUE DEMOCRATIQUE DU CONGO | L'ETUDE PREPARATOIRE POUR LE PROJET DE REHABILITATION ET DE MODERNISATION DE L'AVENUE DES POIDS LOURDS A KINSHASA | INGEROSEC CORPORATION, JAPON | DATE:        | DATE: | N° |
|  |                                  |   |                              | PREPARE PAR: | 2009  |    |
|  |                                  |   |                              | VERIFIE PAR: |       |    |

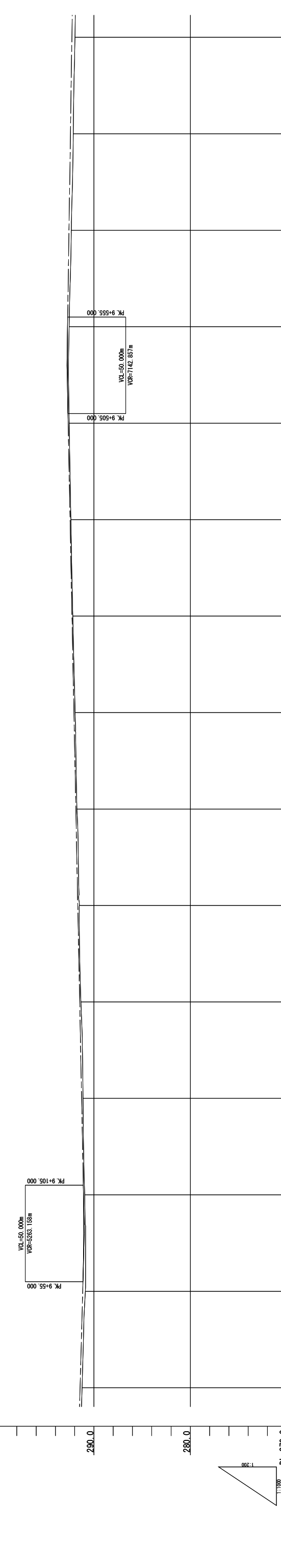
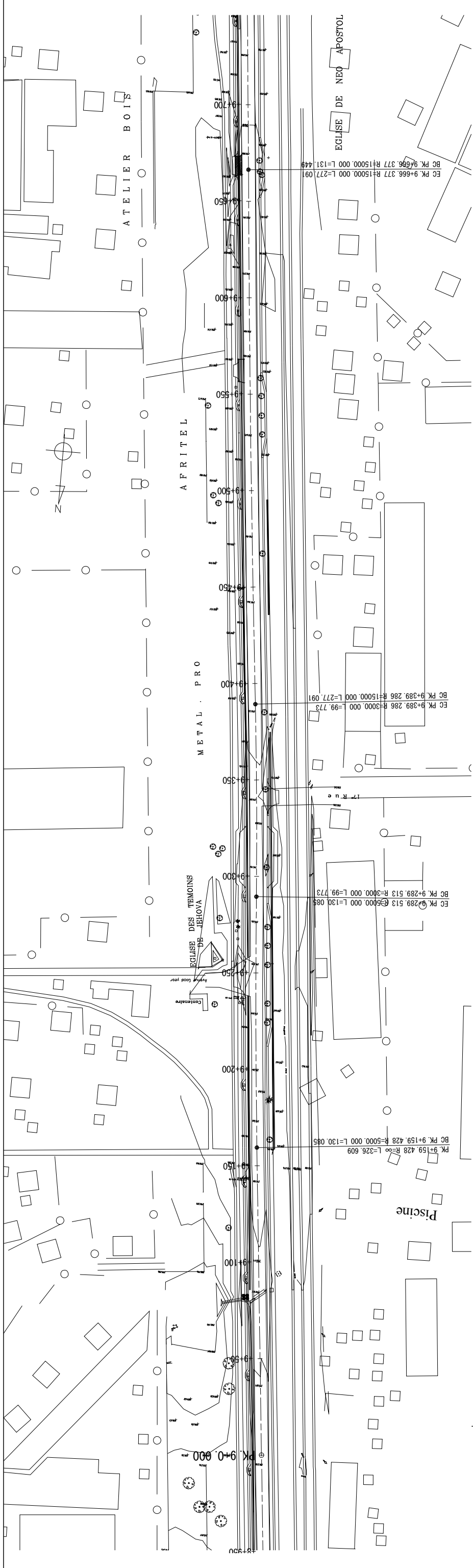

| DECLIVITES                             | 290.0      | 290.2   | 290.4   | 290.6   | 290.8   | 291.0   | 291.2   | 291.4   | 291.6   | 291.8   | 292.0   | 292.2   | 292.4   | 292.6   | 292.8   | 293.0   |
|--|------------|---------|---------|---------|---------|---------|---------|---------|---------|---------|---------|---------|---------|---------|---------|---------|
| COTES DU PROJET                        | 291.132    | 291.159 | 291.199 | 291.232 | 291.274 | 291.312 | 291.351 | 291.392 | 291.436 | 291.482 | 291.530 | 291.579 | 291.630 | 291.682 | 291.736 | 291.792 |
| COTES DU TERRAIN NATUREL               | 291.132    | 291.159 | 291.199 | 291.232 | 291.274 | 291.312 | 291.351 | 291.392 | 291.436 | 291.482 | 291.530 | 291.579 | 291.630 | 291.682 | 291.736 | 291.792 |
| HAUTEURS DES DEBLAIS                   | 0.211      | 0.211   | 0.211   | 0.211   | 0.211   | 0.211   | 0.211   | 0.211   | 0.211   | 0.211   | 0.211   | 0.211   | 0.211   | 0.211   | 0.211   | 0.211   |
| HAUTEURS DES REMBLAIS                  | 0.265      | 0.265   | 0.265   | 0.265   | 0.265   | 0.265   | 0.265   | 0.265   | 0.265   | 0.265   | 0.265   | 0.265   | 0.265   | 0.265   | 0.265   | 0.265   |
| BORNES KILOMETRIQUES                   | PK 9       | 0.211   | 0.422   | 0.633   | 0.844   | 1.055   | 1.266   | 1.477   | 1.688   | 1.899   | 2.110   | 2.321   | 2.532   | 2.743   | 2.954   | 3.165   |
| RACCORDEMENT DE COURBE HORIZONTALE     | L=100.000m |         |         |         |         |         |         |         |         |         |         |         |         |         |         |         |
| RACCORDEMENT DE PENTES DEBRS EN COURBE | L=100.000m |         |         |         |         |         |         |         |         |         |         |         |         |         |         |         |

|  |                                  |   |                              |                                       |   |                                     |              |                 |
|--|----------------------------------|---|------------------------------|---------------------------------------|---|-------------------------------------|--------------|-----------------|
| AGENCE JAPONAISE DE COOPERATION INTERNATIONALE | REPUBLIQUE DEMOCRATIQUE DU CONGO | L'ETUDE PREPARATOIRE POUR LE PROJET DE REHABILITATION ET DE MODERNISATION DE L'AVENUE DES POIDS LOURDS A KINSHASA | INGEROSEC CORPORATION, JAPON | DATE:<br>PREPARE PAR:<br>VERIFIE PAR: | PLAN ET PROFIL (14/18)<br>PK.8+300 - PK.9+000 | ECHELLE<br>A1-1:1.000<br>A3-1:2.000 | DATE<br>2009 | N°<br>CG-BD-D14 |
|--|----------------------------------|---|------------------------------|---------------------------------------|---|-------------------------------------|--------------|-----------------|

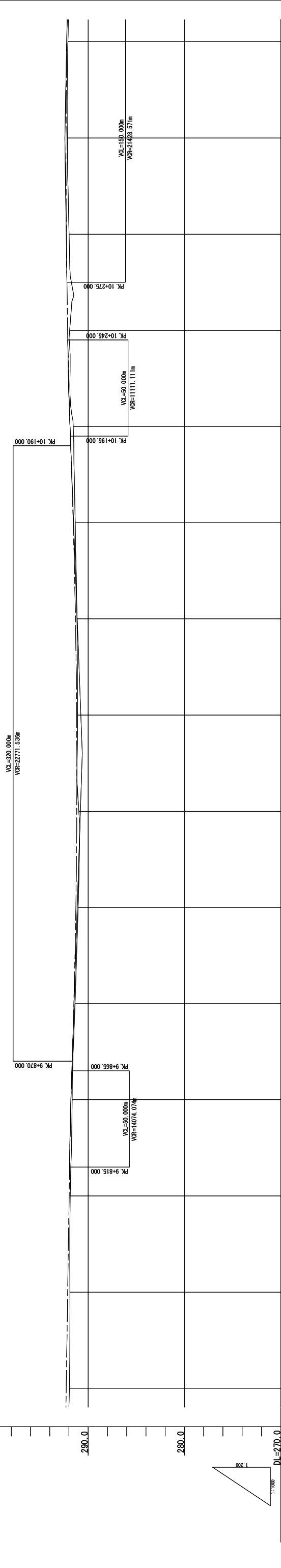
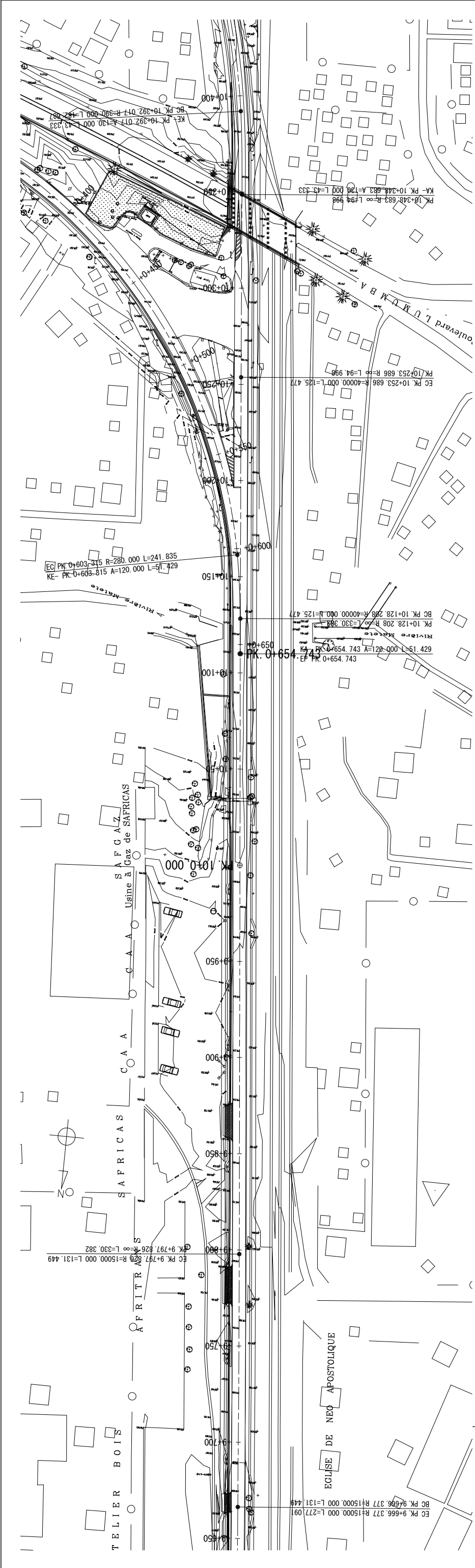

| DECLIVITES                             | 291.864 | 290.619 | 292.434 |
|--|---------|---------|---------|
| COTES DU PROJET                        | 291.700 | 291.179 | 292.305 |
| COTES DU TERRAIN NATUREL               | 291.660 | 291.179 | 292.241 |
| HAUTEURS DES DEBLAIS                   | 291.939 | 291.179 | 292.305 |
| HAUTEURS DES REMBLAIS                  | 291.889 | 291.179 | 292.305 |
| BORNES KILOMETRIQUES                   | 291.908 | 291.179 | 292.241 |
| RACCORDEMENT DE COURBE HORIZONTALE     | 291.908 | 291.179 | 292.241 |
| RACCORDEMENT DE PENTES DEBRS EN COURBE | 291.966 | 291.179 | 292.241 |

| AGENCE JAPONAISE DE COOPERATION INTERNATIONALE | REPUBLIQUE DEMOCRATIQUE DU CONGO | L'ETUDE PREPARATOIRE POUR LE PROJET DE REHABILITATION ET DE MODERNISATION DE L'AVENUE DES POIDS LOURDS A KINSHASA | INGEROSEC CORPORATION, JAPON | DATE:<br>PREPARE PAR:<br>VERIFIE PAR: | PLAN ET PROFIL (15/18)<br>PK.9+700 - PK.10+400 | ECHELLE<br>A1-1:1.000<br>A3-1:2.000 | DATE<br>2009 | N°<br>CG-BD-D15 |
|--|----------------------------------|---|------------------------------|---------------------------------------|--|-------------------------------------|--------------|-----------------|
|--|----------------------------------|---|------------------------------|---------------------------------------|--|-------------------------------------|--------------|-----------------|

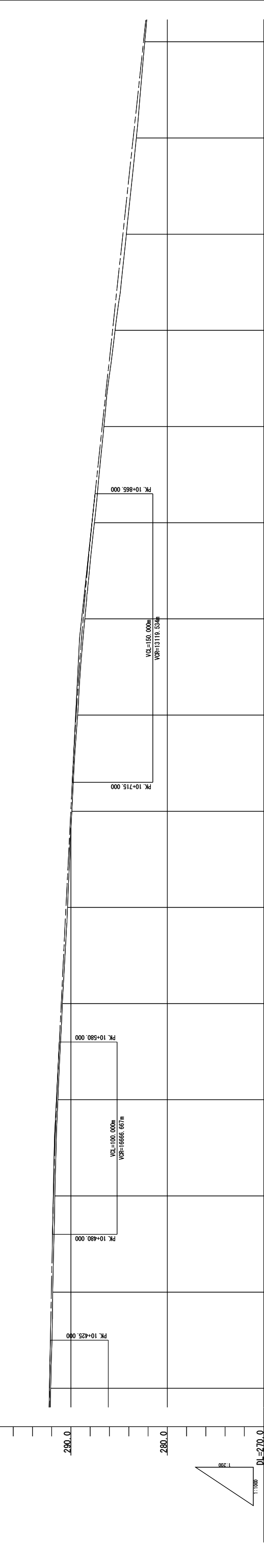
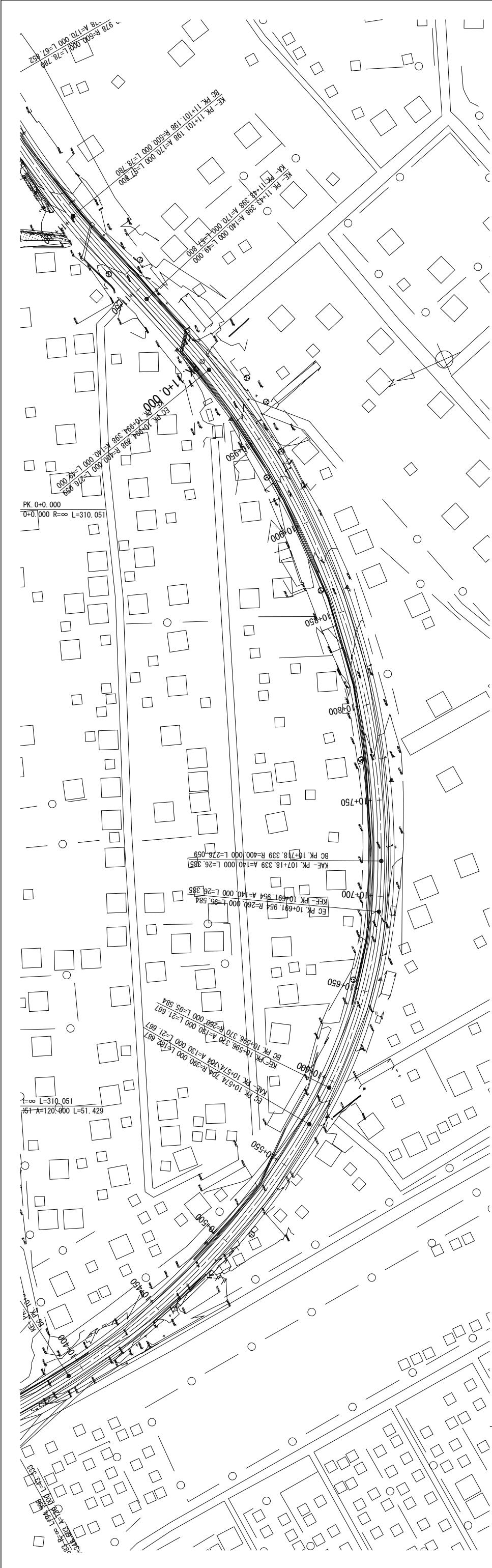

| DECLIVITES                             | 289.114 | 289.114 | 291.714 | 291.714 |
|--|---------|---------|---------|---------|
| COTES DU PROJET                        | 282.339 | 282.428 | 282.349 | 282.428 |
| COTES DU TERRAIN NATUREL               | 283.209 | 283.541 | 283.947 | 283.683 |
| HAUTEURS DES DEBLAIS                   | 0.332   | 0.336   | 0.343   | 0.336   |
| HAUTEURS DES REMBLAIS                  | 0.000   | 0.000   | 0.000   | 0.000   |
| BORNES KILOMETRIQUES                   | 284.253 | 284.613 | 284.970 | 284.733 |
| RACCORDEMENT DE COURBE HORIZONTALE     | 285.434 | 285.685 | 285.936 | 285.685 |
| RACCORDEMENT DE PENTES DEBRS EN COURBE | 286.568 | 286.756 | 286.944 | 286.756 |
|  | 287.506 | 287.819 | 288.094 | 287.819 |
|  | 287.506 | 287.819 | 288.094 | 287.819 |
|  | 288.564 | 288.739 | 289.094 | 288.739 |
|  | 288.564 | 288.739 | 289.094 | 288.739 |
|  | 289.313 | 289.467 | 289.864 | 289.467 |
|  | 289.313 | 289.467 | 289.864 | 289.467 |
|  | 289.719 | 289.830 | 290.014 | 289.830 |
|  | 289.719 | 289.830 | 290.014 | 289.830 |
|  | 289.906 | 290.014 | 290.094 | 290.014 |
|  | 289.906 | 290.014 | 290.094 | 290.014 |
|  | 290.358 | 290.514 | 290.514 | 290.514 |
|  | 290.358 | 290.514 | 290.514 | 290.514 |
|  | 290.886 | 291.050 | 291.050 | 291.050 |
|  | 290.886 | 291.050 | 291.050 | 291.050 |
|  | 291.214 | 291.266 | 291.266 | 291.266 |
|  | 291.214 | 291.266 | 291.266 | 291.266 |
|  | 291.574 | 291.704 | 291.704 | 291.704 |
|  | 291.574 | 291.704 | 291.704 | 291.704 |
|  | 291.914 | 291.914 | 291.914 | 291.914 |
|  | 291.914 | 291.914 | 291.914 | 291.914 |
|  | 291.892 | 292.034 | 292.034 | 292.034 |
|  | 291.892 | 292.034 | 292.034 | 292.034 |
|  | 292.134 | 292.134 | 292.134 | 292.134 |
|  | 292.107 | 292.219 | 292.219 | 292.219 |
|  | 292.107 | 292.219 | 292.219 | 292.219 |
|  | 292.138 | 292.241 | 292.241 | 292.241 |
|  | 292.138 | 292.241 | 292.241 | 292.241 |

|  |                                   |   |  |                              |                                       |   |                                     |              |                 |
|--|-----------------------------------|---|--|------------------------------|---------------------------------------|---|-------------------------------------|--------------|-----------------|
| AGENCE JAPONAISE DE COOPERATION INTERNATIONALE | REPUBLICQUE DEMOCRATIQUE DU CONGO | L'ETUDE PREPARATOIRE POUR LE PROJET DE REHABILITATION ET DE MODERNISATION DE L'AVENUE DES POIDS LOURDS A KINSHASA |  | INGEROSEC CORPORATION, JAPON | DATE:<br>PREPARE PAR:<br>VERIFIE PAR: | PLAN ET PROFIL (16/18)<br>PK.10+400 - PK.11+100 | ECHELLE<br>A1-1:1.000<br>A3-1:2.000 | DATE<br>2009 | N°<br>CG-BD-D16 |
|--|-----------------------------------|---|--|------------------------------|---------------------------------------|---|-------------------------------------|--------------|-----------------|

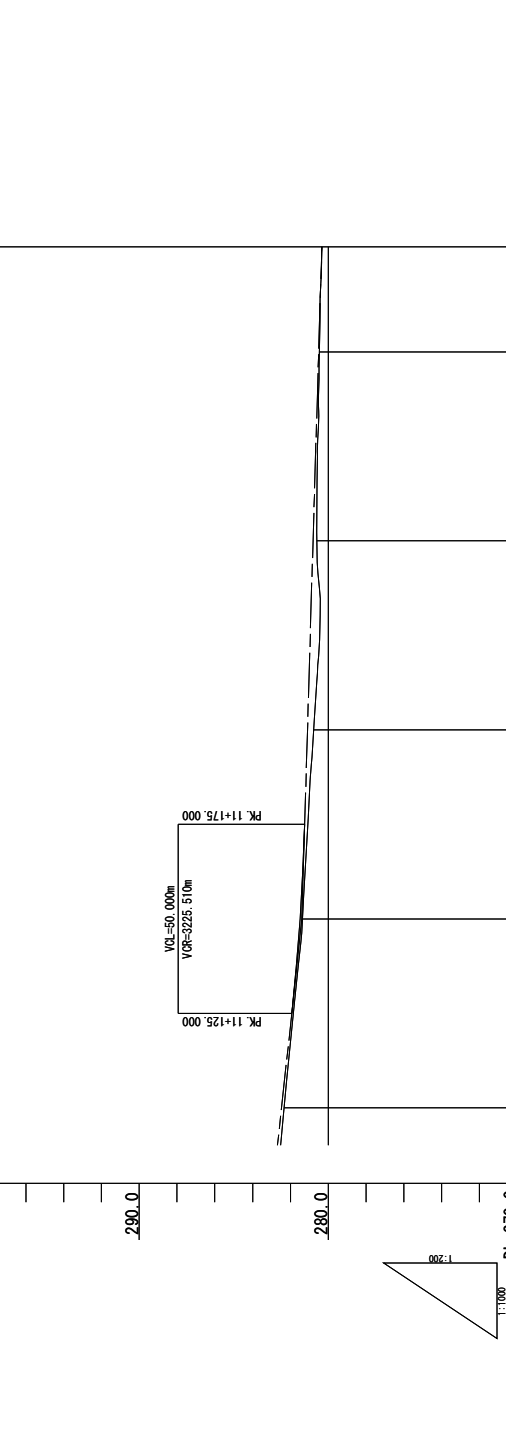
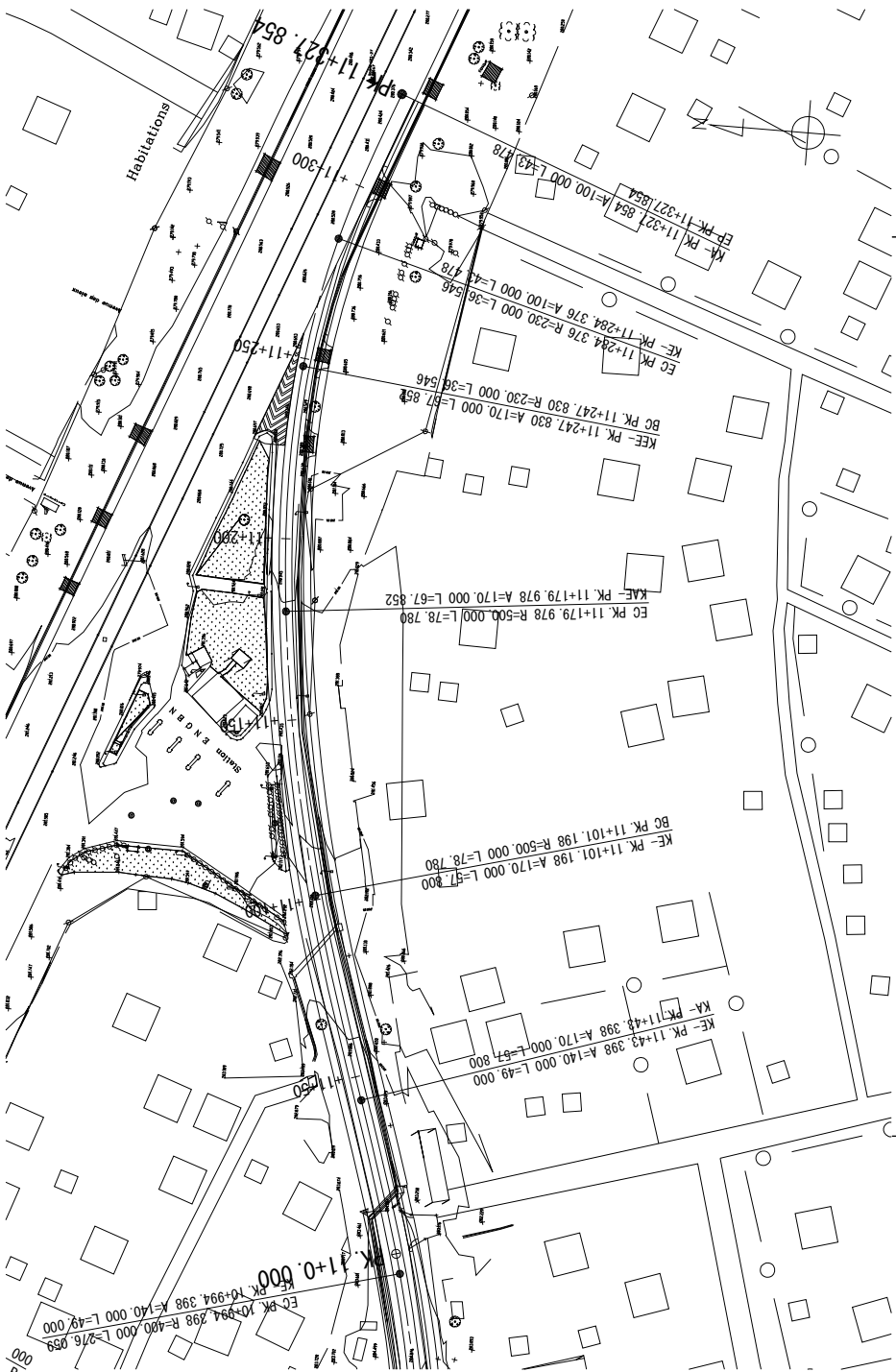

| DECLIVITES                             | 281.934  |         | 281.361 |         | 281.027 |         | 280.774 |         | 280.506 |         | 280.471 |         | 280.343 |         |
|--|--|---------|---------|---------|---------|---------|---------|---------|---------|---------|---------|---------|---------|---------|
| COTES DU PROJET                        | 282.428  | 281.934 | 281.361 | 281.027 | 280.774 | 280.506 | 280.471 | 280.343 |         |         |         |         |         |         |
| COTES DU TERRAIN NATUREL               | 282.428  | 281.934 | 281.361 | 281.027 | 280.774 | 280.506 | 280.471 | 280.343 |         |         |         |         |         |         |
| HAUTEURS DES DEBLAIS                   | 0.133  | 0.133   | 0.133   | 0.133   | 0.133   | 0.133   | 0.133   | 0.133   |         |         |         |         |         |         |
| HAUTEURS DES REMBLAIS                  | 0.133  | 0.133   | 0.133   | 0.133   | 0.133   | 0.133   | 0.133   | 0.133   |         |         |         |         |         |         |
| BORNES KILOMETRIQUES                   | 100.000  | 150.000 | 200.000 | 250.000 | 300.000 | 350.000 | 400.000 | 450.000 | 500.000 | 550.000 | 600.000 | 650.000 | 700.000 | 750.000 |
| RACCORDEMENT DE COURBE HORIZONTALE     | [Diagram showing horizontal curve alignment with stationing markers] |         |         |         |         |         |         |         |         |         |         |         |         |         |
| RACCORDEMENT DE PENTES DEBRS EN COURBE | [Diagram showing vertical curve alignment with stationing markers]   |         |         |         |         |         |         |         |         |         |         |         |         |         |







# PLAN DU CARREFOR DE LA 14<sup>ème</sup>RUE

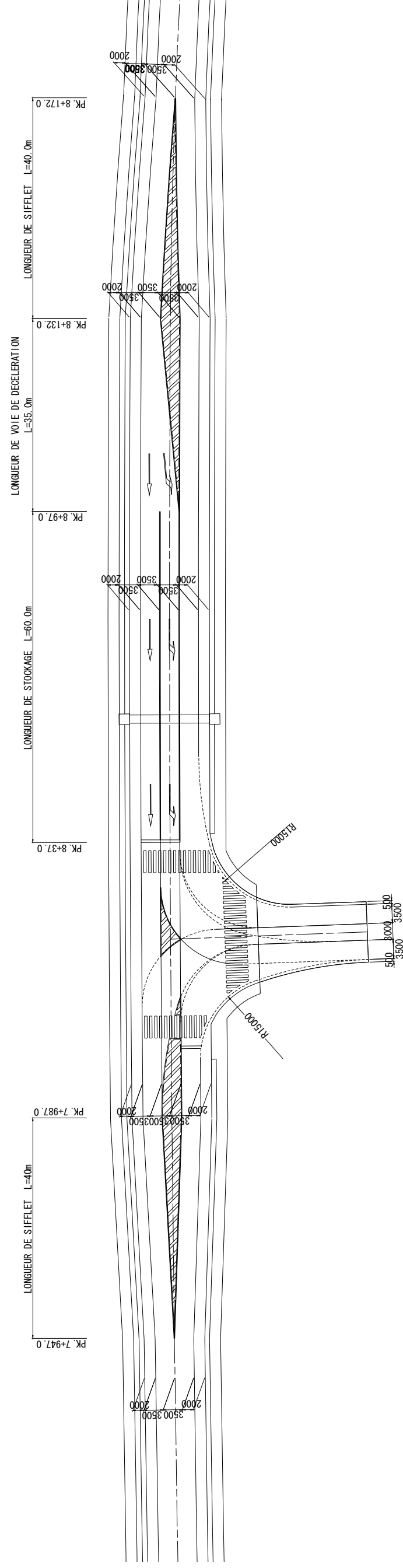

AGENCE JAPONAISE DE  
COOPERATION INTERNATIONALE

REPUBLIQUE  
DEMOCRATIQUE DU CONGO

L'ETUDE PREPARATOIRE POUR  
LE PROJET DE REHABILITATION ET  
DE LA MODERNISATION DE L'AVENUE  
DES POIDS LOURDS A KINSHASA

INGEROSEC CORPORATION,  
JAPON

DATE:  
PREPARE PAR:  
VERIFIE PAR:

PLAN DU CARREFOR DE LA 14<sup>ème</sup>RUE

ECHELLE  
A1-1:400  
A3-1:800

DATE  
2009

N°  
CG-BD-D20

PLAN DE DRAINAGE (1)  
FOSSÉ

ECHELLE A1 1:20  
A3 1:40

FOSSÉ EN "U"

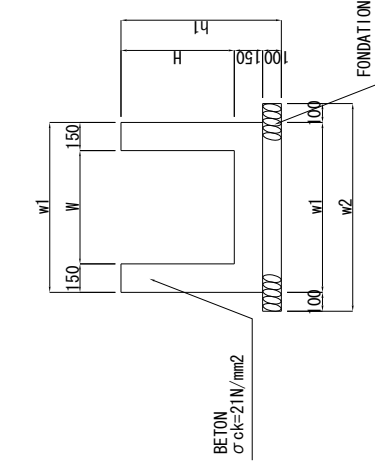

LISTE DES PRINCIPALES

| ARTICLE        | DIMENSIONS |     |      |      | REMARQUES |
|----------------|------------|-----|------|------|-----------|
|                | W          | H   | w1   | w2   |           |
| W 300 - H 400  | 300        | 400 | 600  | 800  | 650       |
| W 400 - H 400  | 400        | 400 | 700  | 900  | 650       |
| W 500 - H 500  | 500        | 500 | 800  | 1000 | 750       |
| W 600 - H 600  | 600        | 600 | 900  | 1100 | 850       |
| W 800 - H 800  | 800        | 800 | 1100 | 1300 | 750       |
| W 900 - H 900  | 900        | 900 | 1200 | 1400 | 1150      |
| W 1100 - H 900 | 1100       | 900 | 1400 | 1600 | 750       |

FOSSÉ EN "U" AVEC COUVERTURE

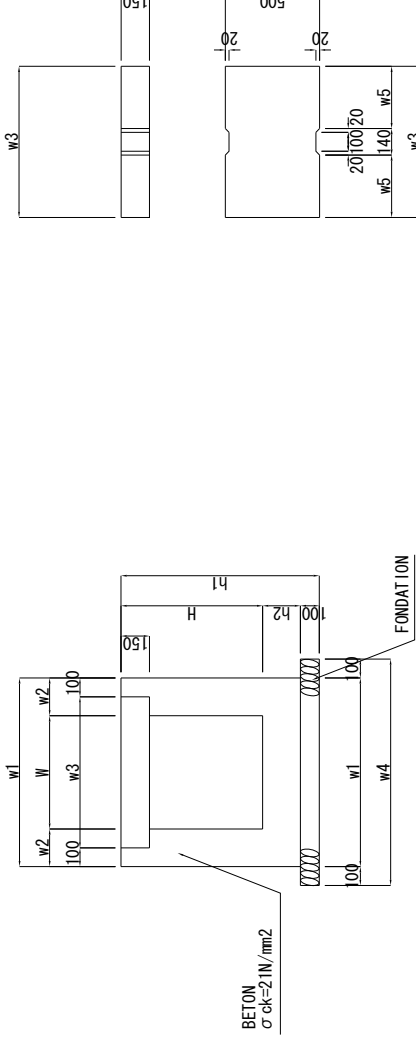

LISTE DES PRINCIPALES

| ARTICLE        | DIMENSIONS |      |      |     | REMARQUES |
|----------------|------------|------|------|-----|-----------|
|                | W          | H    | w1   | w2  |           |
| W 300 - H 550  | 300        | 550  | 600  | 150 | 400       |
| W 500 - H 650  | 500        | 650  | 1000 | 200 | 700       |
| W 600 - H 750  | 600        | 750  | 1000 | 200 | 800       |
| W 800 - H 950  | 800        | 950  | 1200 | 200 | 1000      |
| W 900 - H 1050 | 900        | 1050 | 1300 | 200 | 1100      |

LISTE DES PRINCIPALES

| ARTICLE        | DIMENSIONS |      |     |    | REMARQUES |
|----------------|------------|------|-----|----|-----------|
|                | w3         | w4   | w5  | w6 |           |
| W 300 - H 550  | 400        | 800  | 130 |    |           |
| W 500 - H 650  | 700        | 1100 | 280 |    |           |
| W 600 - H 750  | 800        | 1200 | 330 |    |           |
| W 800 - H 950  | 1000       | 1400 | 430 |    |           |
| W 900 - H 1050 | 1100       | 1500 | 480 |    |           |

PUISARD TYPE 1

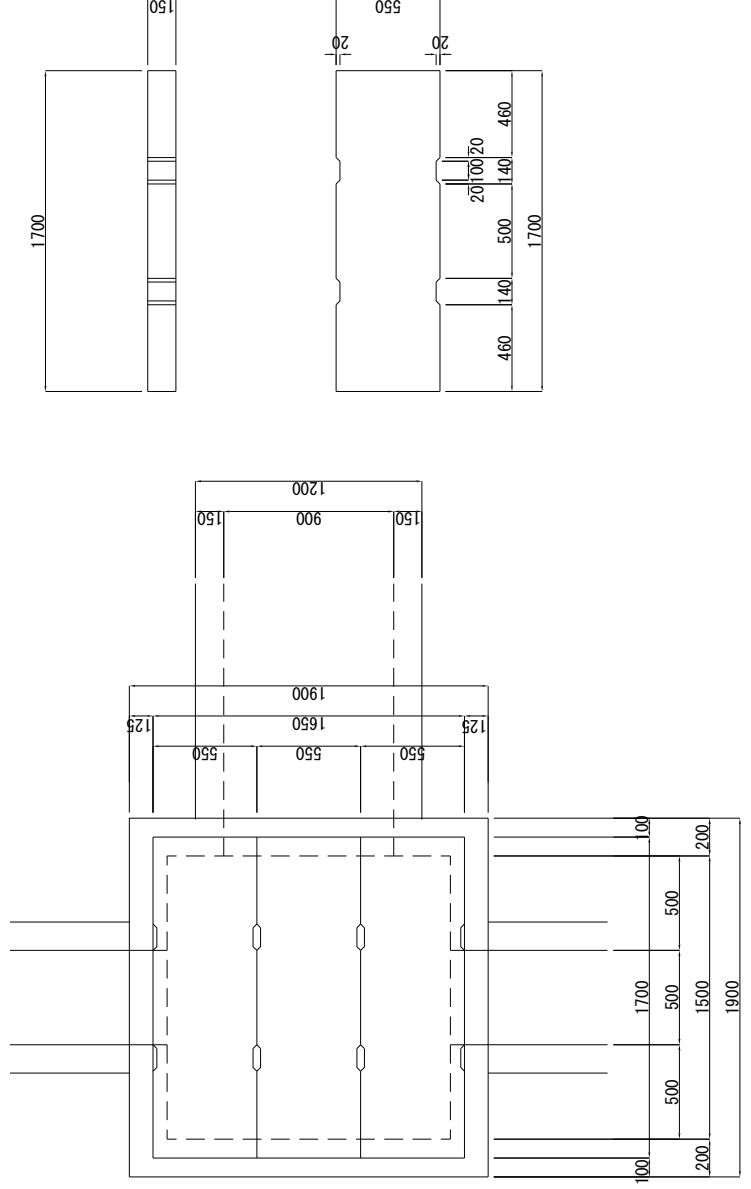
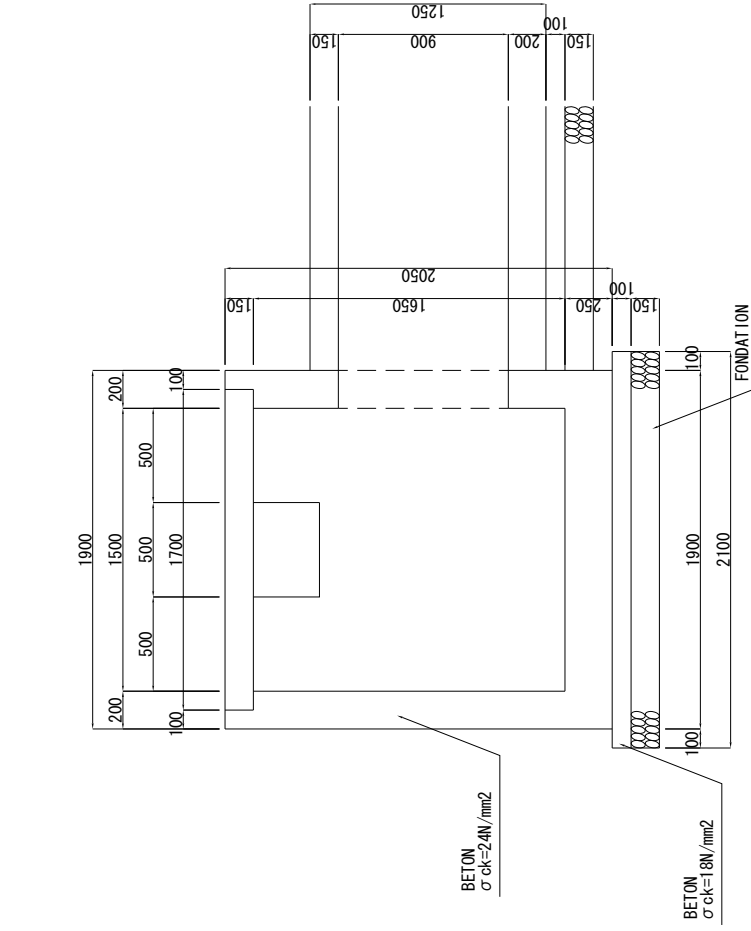

AGENCE JAPONAISE DE  
COOPERATION INTERNATIONALE

REPUBLIQUE  
DEMOCRATIQUE DU CONGO

L'ETUDE PREPARATOIRE POUR  
LE PROJET DE REHABILITATION ET  
DE MODERNISATION DE L'AVENUE  
DES POIDS LOURDS A KINSHASA

INGEROSEC CORPORATION,  
JAPON

DATE:  
PREPARE PAR:  
VERIFIE PAR:

PLAN DE DRAINAGE (1)

ECHELLE  
COMME VU

DATE

N°

2009

CG-BD-E1

# PLAN DE DRAINAGE (2)

ECHELLE A1 1:20  
A3 1:40

## PUISARD TYPE 2

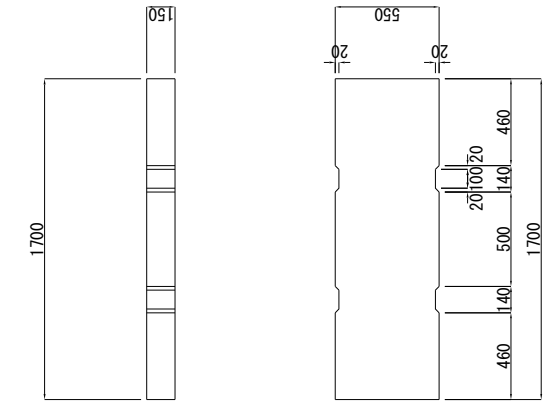
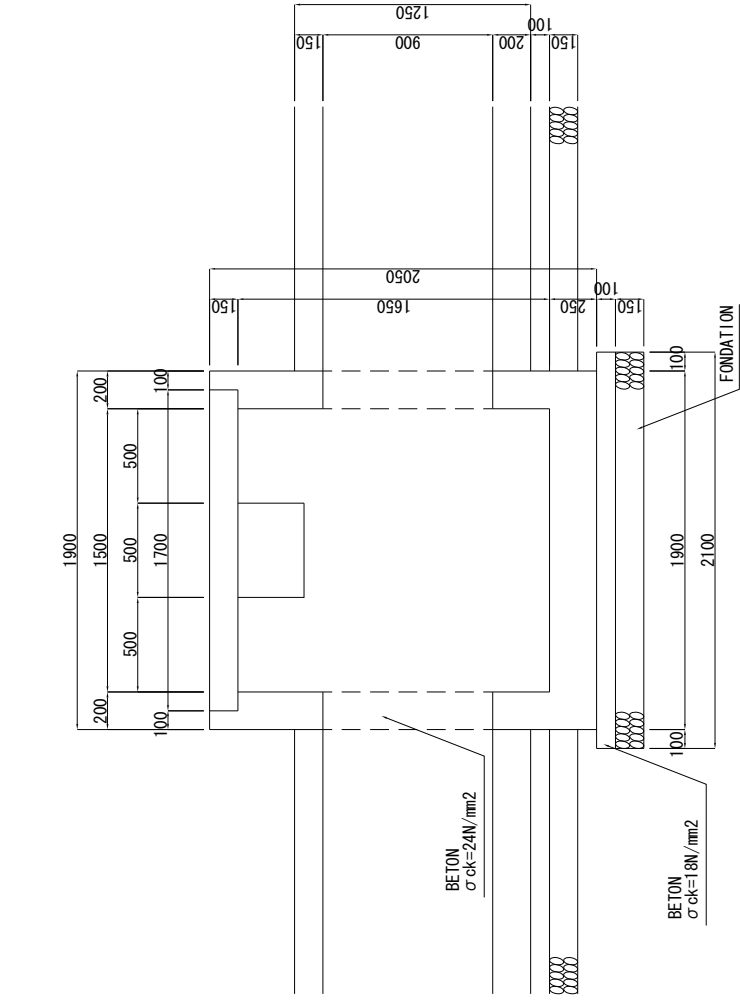

## PUISARD TYPE 3

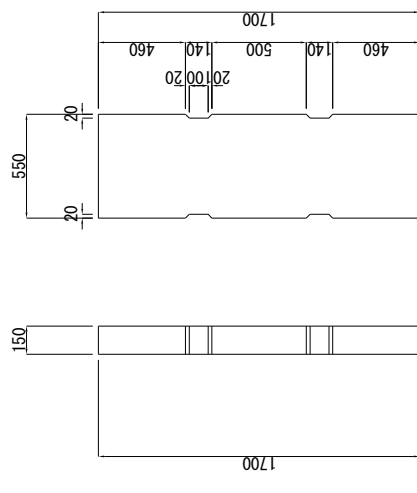
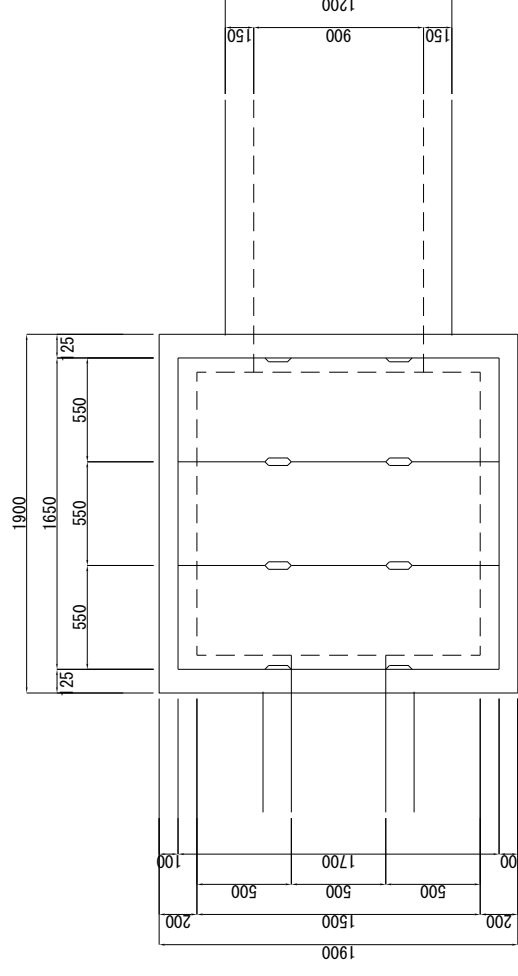
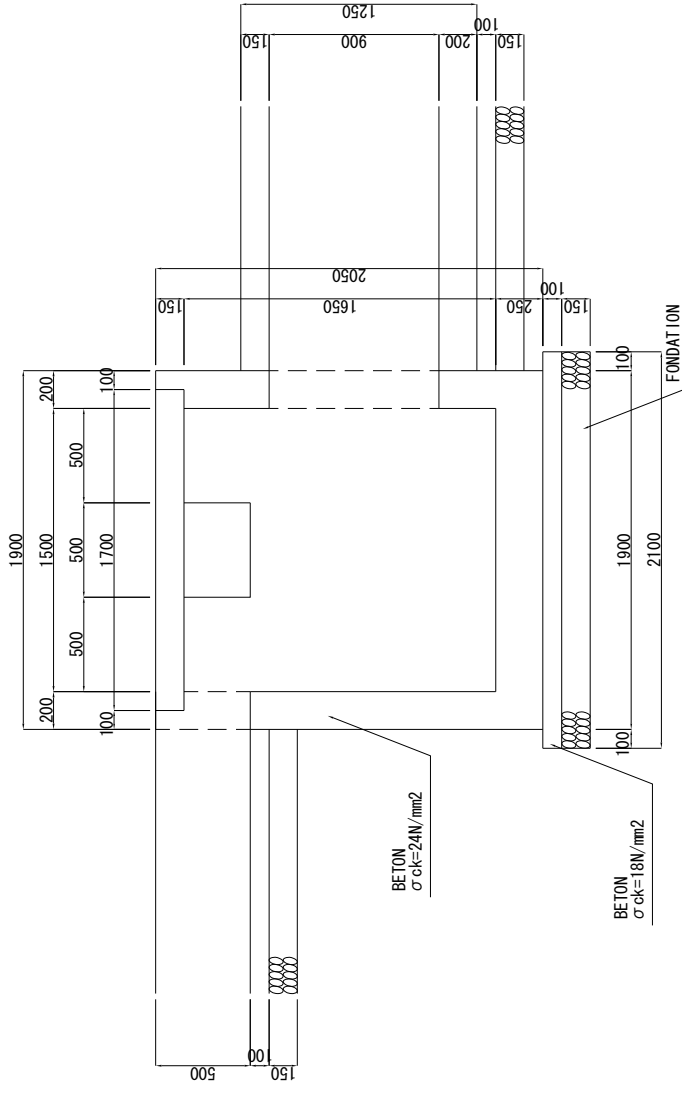

AGENCE JAPONAISE DE  
COOPERATION INTERNATIONALE

REPUBLIQUE  
DEMOCRATIQUE DU CONGO

L'ETUDE PREPARATOIRE POUR  
LE PROJET DE REHABILITATION ET  
DE MODERNISATION DE L'AVENUE  
DES POIDS LOURDS A KINSHASA

INGEROSEC CORPORATION,  
JAPON

DATE:  
PREPARE PAR:  
VERIFIE PAR:

PLAN DE DRAINAGE (2)

ECHELLE  
COMME VU

DATE

N°

2009

CG-BD-E2

# PLAN DE DRAINAGE (3)

## DALOT

ECHELLE A1 1:20  
A3 1:40

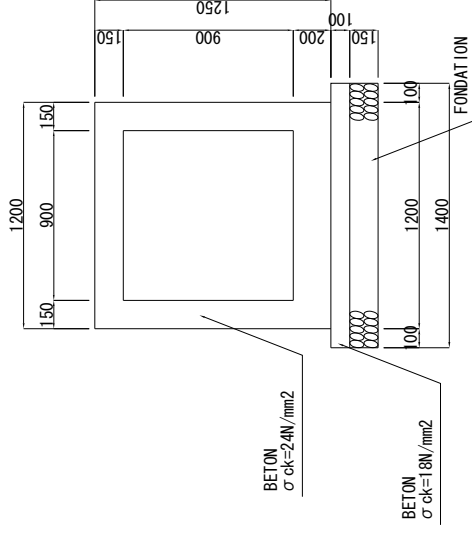

## EXUTOIRE

ECHELLE A1 1:50  
A3 1:100

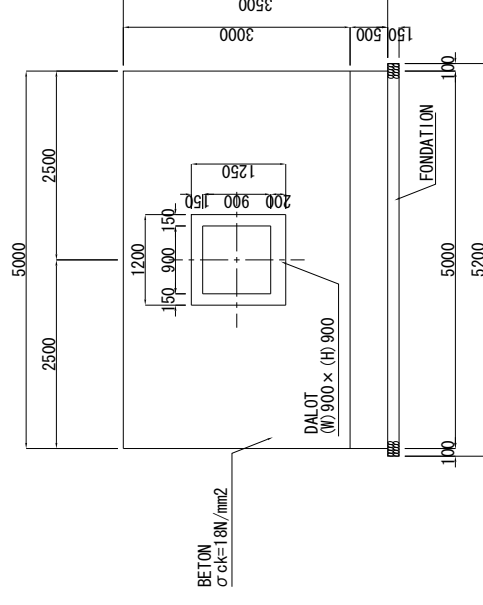
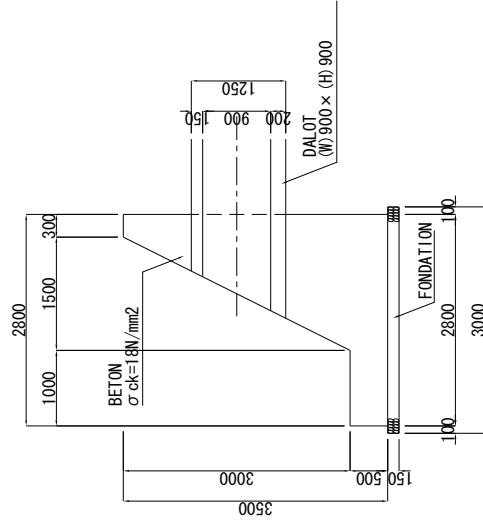

AGENCE JAPONAISE DE  
COOPERATION INTERNATIONALE

REPUBLIQUE  
DEMOCRATIQUE DU CONGO

L'ETUDE PREPARATOIRE POUR  
LE PROJET DE REHABILITATION ET  
DE MODERNISATION DE L'AVENUE  
DES POIDS LOURDS A KINSHASA

INGEROSEC CORPORATION,  
JAPON

DATE:  
PREPARE PAR:  
VERIFIE PAR:

PLAN DE DRAINAGE (3)

ECHELLE  
COMME VU

DATE  
2009

N°  
CG-BD-E3



# PLAN DE ARRÊT DE BUS (TYPE2)

## PLAN

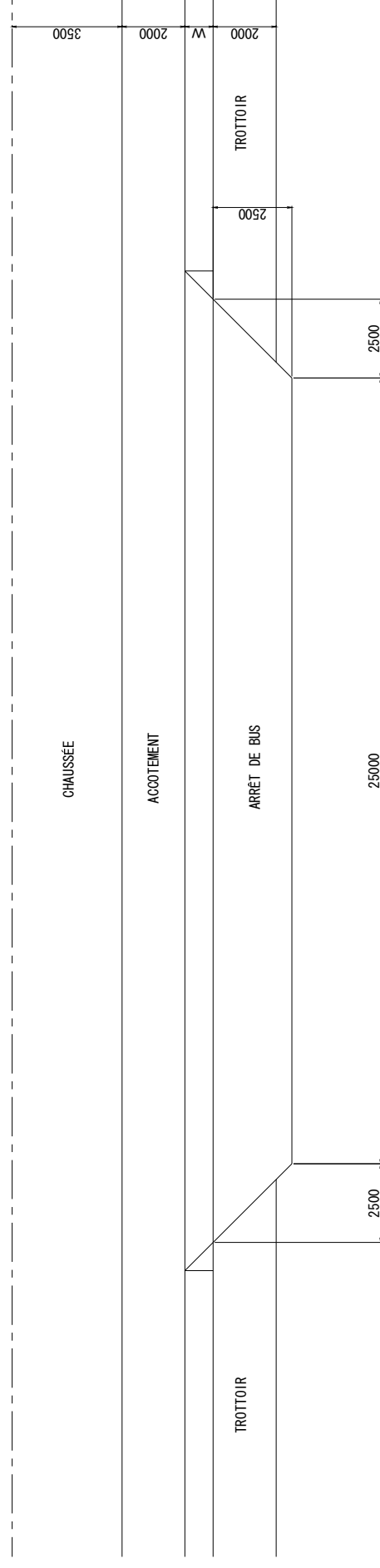

## PROFIL EN TRAVERS

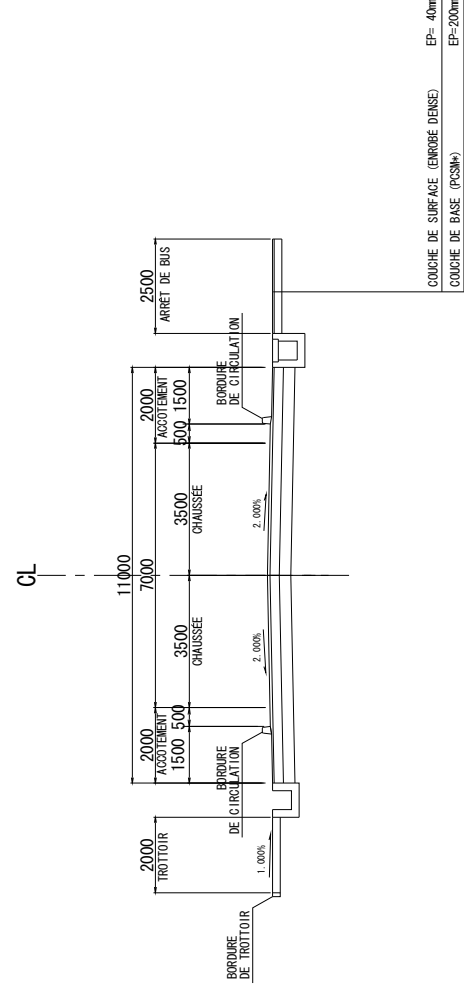

|  |                                  |   |                              |                              |                              |  |                                    |              |                |
|--|----------------------------------|---|------------------------------|------------------------------|------------------------------|--|------------------------------------|--------------|----------------|
| AGENCE JAPONAISE DE COOPERATION INTERNATIONALE | REPUBLIQUE DEMOCRATIQUE DU CONGO | L'ETUDE PREPARATOIRE POUR LE PROJET DE REHABILITATION ET DE MODERNISATION DE L'AVENUE DES POIDS LOURDS A KINSHASA | INGEROSEC CORPORATION, JAPON | DATE:                        | PLAN DE ARRÊT DE BUS (TYPE2) |  | EHELLE<br>A1 1 : 200<br>A3 1 : 400 | DATE<br>2009 | N°<br>CG-BD-F2 |
|  |                                  |   |                              | PREPARE PAR:<br>VERIFIE PAR: |                              |  |                                    |              |                |



# PLAN DE L' AIRE DE STATIONNEMENT

## PLAN

ECHELLE A1 1:200  
A3 1:400

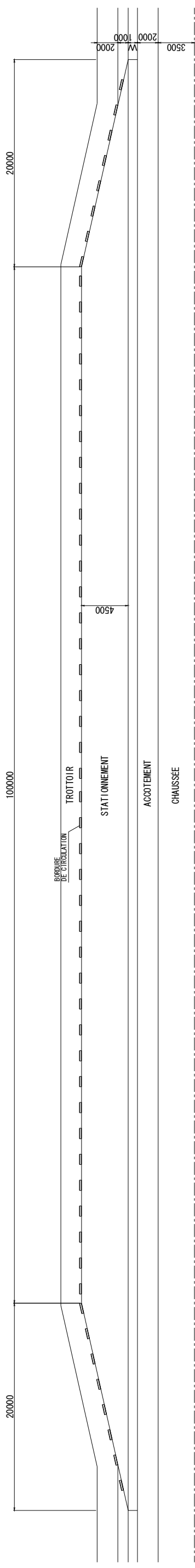

## PROFIL EN TRAVERS

ECHELLE A1 1:100  
A3 1:200

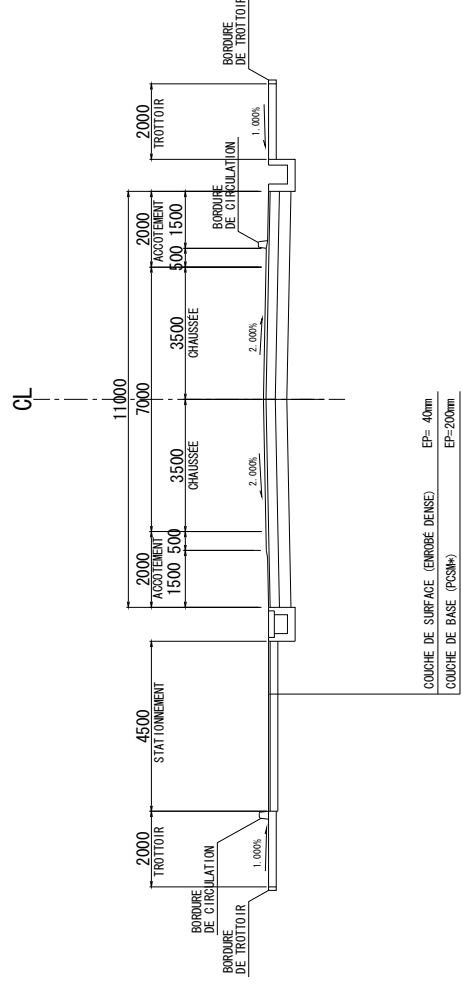

|  |                                  |   |                              |              |                                  |         |          |    |
|--|----------------------------------|---|------------------------------|--------------|----------------------------------|---------|----------|----|
| AGENCE JAPONAISE DE COOPERATION INTERNATIONALE | REPUBLIQUE DEMOCRATIQUE DU CONGO | L'ETUDE PREPARATOIRE POUR LE PROJET DE REHABILITATION ET DE MODERNISATION DE L'AVENUE DES POIDS LOURDS A KINSHASA | INGEROSEC CORPORATION, JAPON | DATE:        | PLAN DE L' AIRE DE STATIONNEMENT | ECHELLE | DATE     | N° |
|  |                                  |   |                              | PREPARE PAR: | COMME VU                         | 2009    | CG-BD-F3 |    |
|  |                                  |   |                              | VERIFIE PAR: |                                  |         |          |    |

# PLAN D' AIRE D' ARRÊT D' URGENCE (TYPE1)

## PLAN

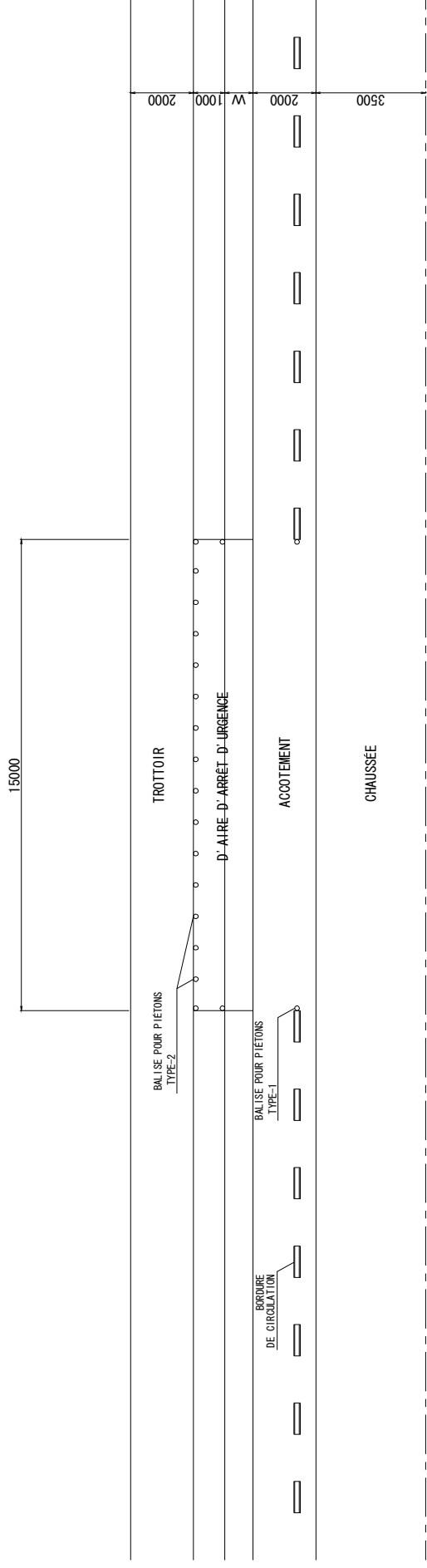

## PROFIL EN TRAVERS

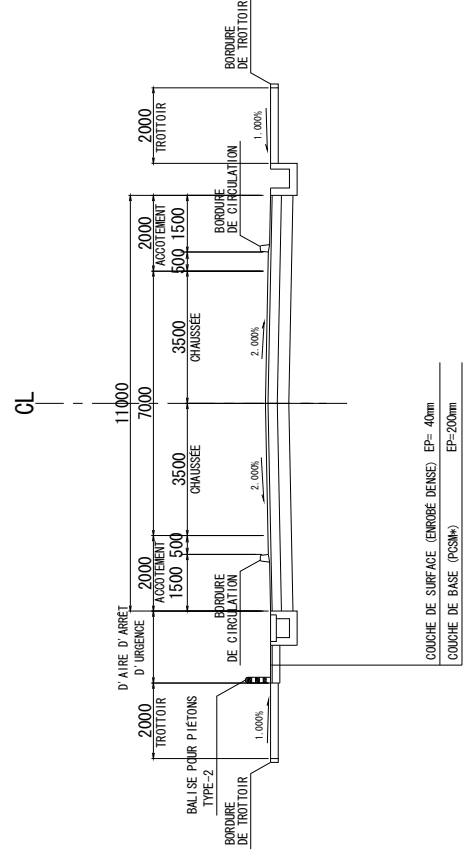

|  |                                  |   |                              |       |              |              |  |                                     |              |                |
|--|----------------------------------|---|------------------------------|-------|--------------|--------------|--|-------------------------------------|--------------|----------------|
| AGENCE JAPONAISE DE COOPERATION INTERNATIONALE | REPUBLIQUE DEMOCRATIQUE DU CONGO | L'ETUDE PREPARATOIRE POUR LE PROJET DE REHABILITATION ET DE MODERNISATION DE L'AVENUE DES POIDS LOURDS A KINSHASA | INGEROSEC CORPORATION, JAPON | DATE: | PREPARE PAR: | VERIFIE PAR: | PLAN D' AIRE D' ARRÊT D' URGENCE (TYPE1) | ECHELLE<br>A1 1 : 200<br>A3 1 : 400 | DATE<br>2009 | N°<br>CG-BD-F4 |
|  |                                  |   |                              |       |              |              |  |                                     |              |                |

# PLAN D' AIRE D' ARRÊT D' URGENCE (TYPE2)

## PLAN

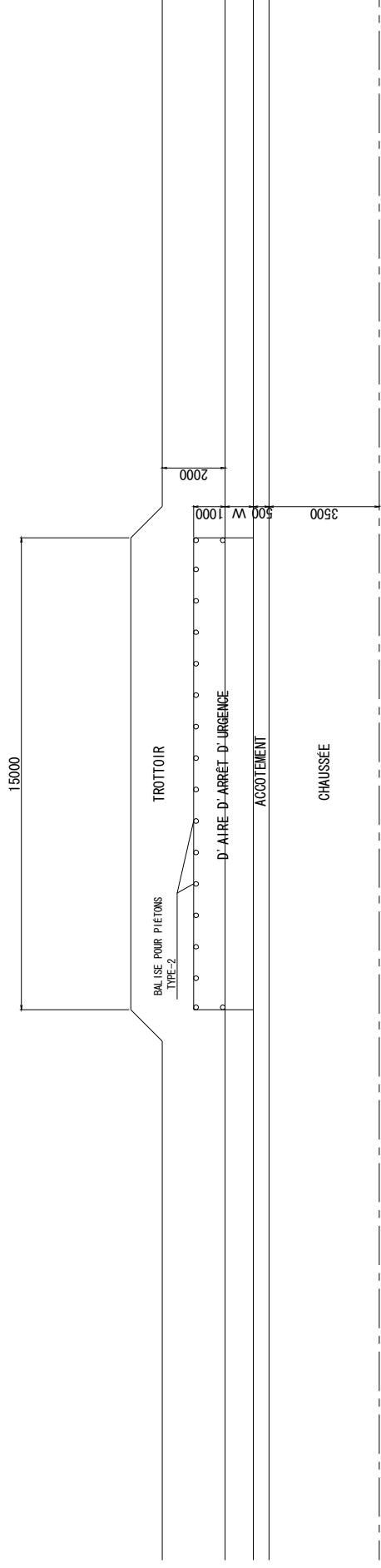

## PROFIL EN TRAVERS

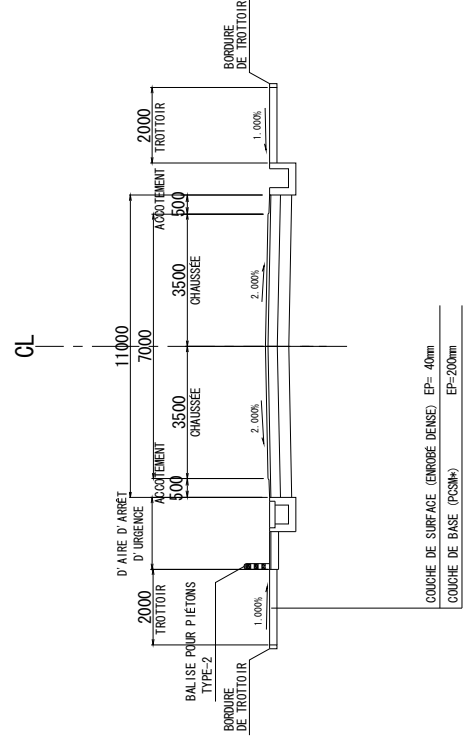

|  |                                  |   |                              |              |              |                                     |                |
|--|----------------------------------|---|------------------------------|--------------|--------------|-------------------------------------|----------------|
| AGENCE JAPONAISE DE COOPERATION INTERNATIONALE | REPUBLIQUE DEMOCRATIQUE DU CONGO | L'ETUDE PREPARATOIRE POUR LE PROJET DE REHABILITATION ET DE MODERNISATION DE L'AVENUE DES POIDS LOURDS A KINSHASA | INGEROSEC CORPORATION, JAPON | DATE:        | DATE:        | ECHELLE<br>A1 1 : 200<br>A3 1 : 400 | N°<br>CG-BD-F5 |
|  |                                  |   |                              | PREPARE PAR: | PREPARE PAR: |                                     |                |
|  |                                  |   |                              | VERIFIE PAR: |              |                                     |                |

# ROUTE D'ACCÈS (TYPE1)

PK0+000 - PK3+540

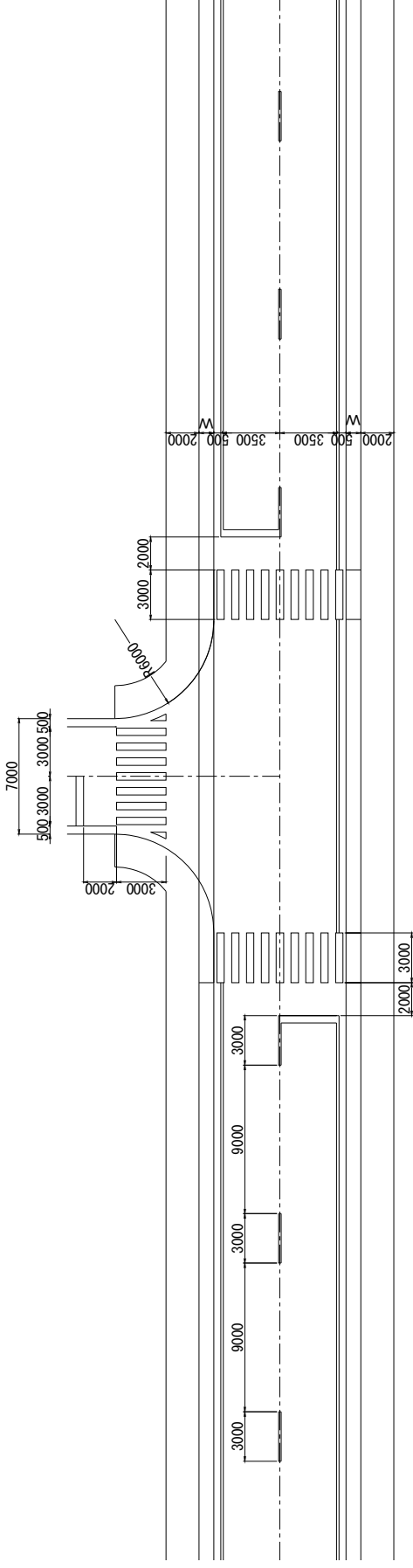

PK3+540 - PK10+330

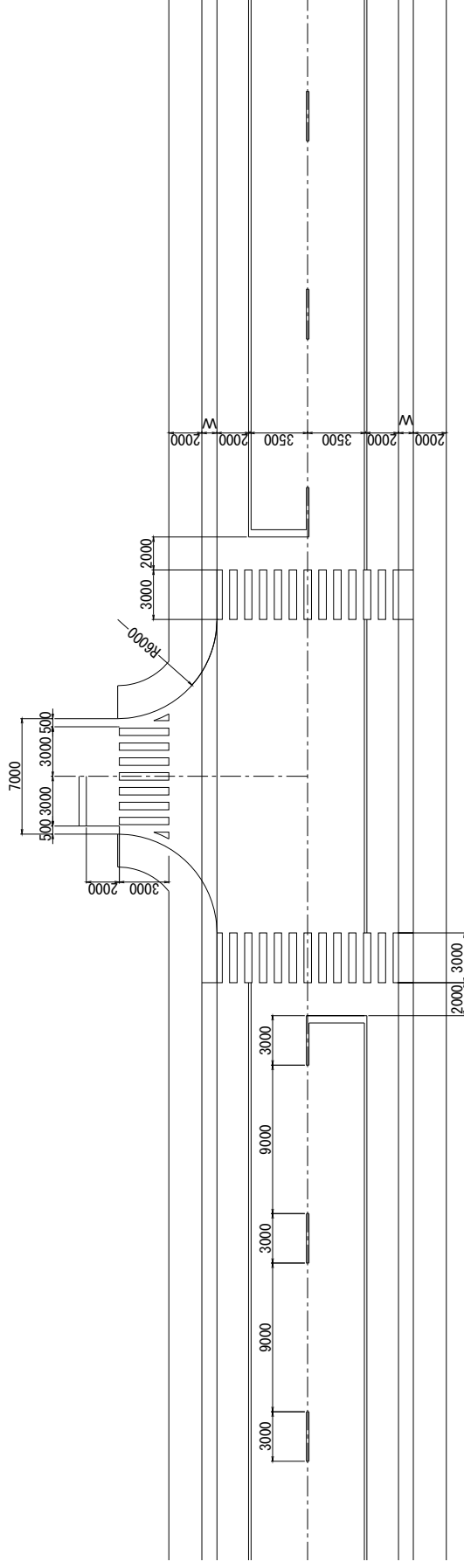

PROFIL EN TRAVERS ECHELLE A1 1:100  
A3 1:200

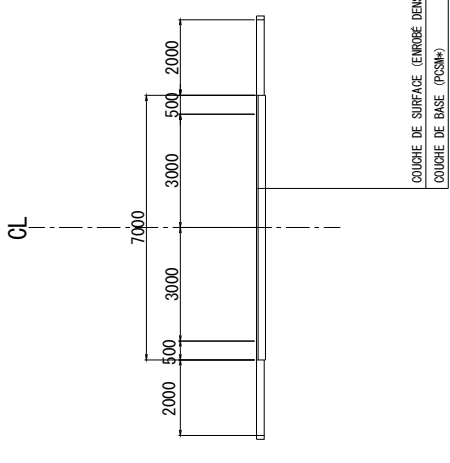

| PK       | CG/CD | Remarks                |
|----------|-------|------------------------|
| 1 0+030  | CG    | Bitish Ngobila         |
| 2 0+200  | CG    |                        |
| 3 1+265  | CD    | Bitshakutshaku         |
| 4 2+660  | CG    | Ave des inflammables   |
| 5 3+970  | CG    | Avenue des brasserie   |
| 6 5+005  | CG    | Avenue de la plaine    |
| 7 5+705  | CG    | Avenue TP Mandrandelle |
| 8 5+745  | CG    | Avenue TP Mandrandelle |
| 9 7+200  | CG    | Yuzam                  |
| 10 7+480 | CG    | Yuzam                  |
| 11 9+250 | CG    | Avenue good year       |
| 12 9+340 | CD    | 17 Rue                 |

|  |                                  |   |                              |                              |                       |                      |      |          |
|--|----------------------------------|---|------------------------------|------------------------------|-----------------------|----------------------|------|----------|
| AGENCE JAPONAISE DE COOPERATION INTERNATIONALE | REPUBLIQUE DEMOCRATIQUE DU CONGO | L'ETUDE PREPARATOIRE POUR LE PROJET DE REHABILITATION ET DE MODERNISATION DE L'AVENUE DES POIDS LOURDS A KINSHASA | INGEROSEC CORPORATION, JAPON | DATE:                        | ROUTE D'ACCÈS (TYPE1) | ECHELLE              | DATE | N°       |
|  |                                  |   |                              | PREPARE PAR:<br>VERIFIE PAR: |                       | A1 1:200<br>A3 1:400 | 2009 | CG-BD-F6 |

# ROUTE D' ACCÈS (TYPE2)

PK0+000 - PK3+540

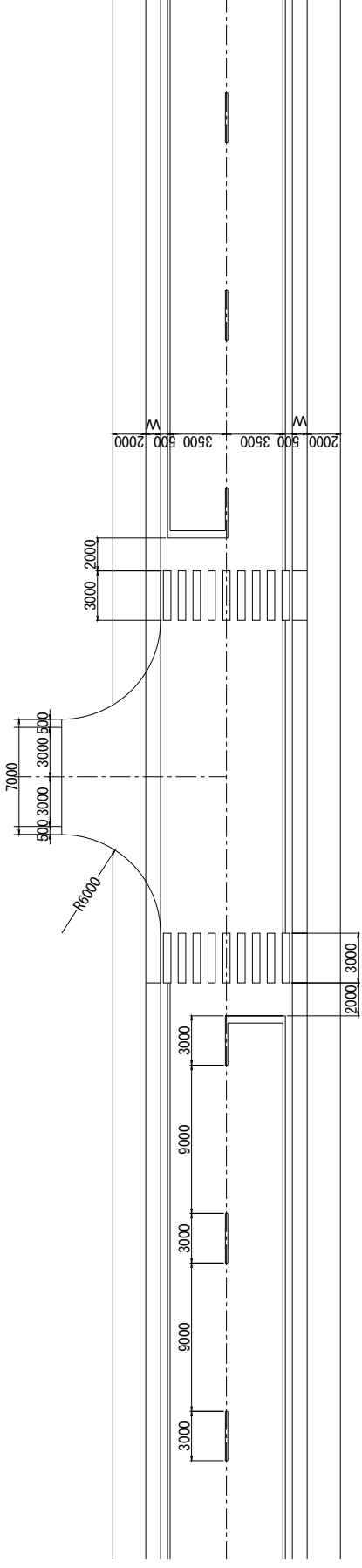

PROFIL EN TRAVERS ECHELLE A1 1:100  
A3 1:200

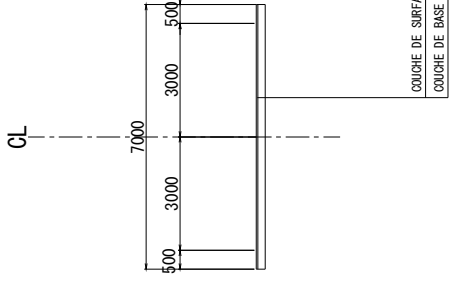

PK3+540 - PK10+330

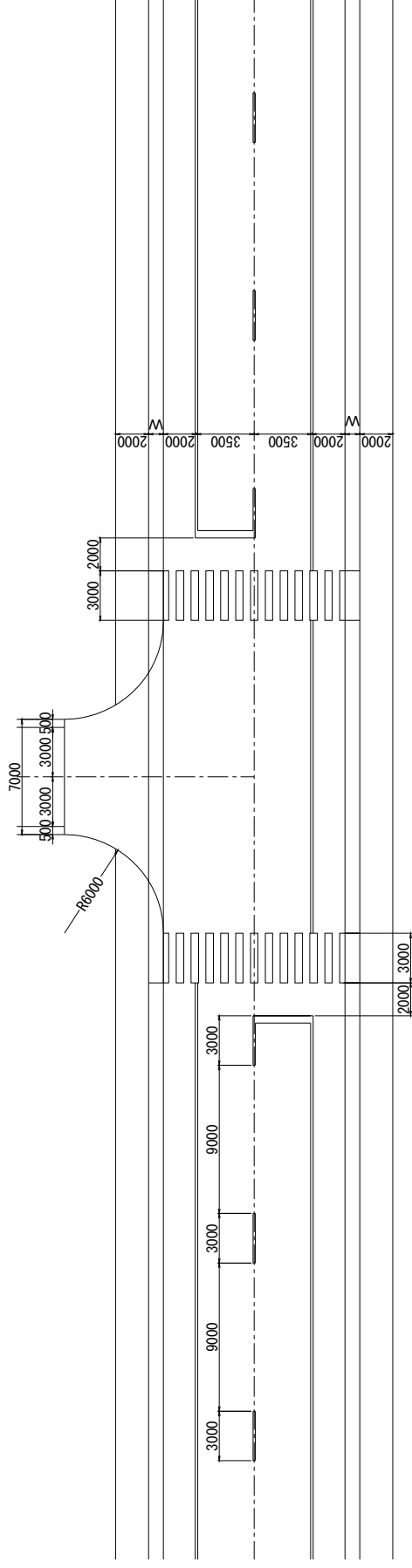

| PK       | CG/CD | Remarks              |
|----------|-------|----------------------|
| 1 0+865  | CG    |                      |
| 2 2+230  | CG    | BRALIMA              |
| 3 3+830  | CG    |                      |
| 4 4+240  | CG    | Avenue metalurgie    |
| 5 4+515  | CG    | Avenue des entrepots |
| 6 4+655  | CG    | Avenue kingabwa      |
| 7 5+090  | CG    |                      |
| 8 5+430  | CG    | Office des route     |
| 9 10+450 | CD    |                      |

|  |                                  |   |                              |                              |                      |      |          |
|--|----------------------------------|---|------------------------------|------------------------------|----------------------|------|----------|
| AGENCE JAPONAISE DE COOPERATION INTERNATIONALE | REPUBLIQUE DEMOCRATIQUE DU CONGO | L'ETUDE PREPARATOIRE POUR LE PROJET DE REHABILITATION ET DE MODERNISATION DE L'AVENUE DES POIDS LOURDS A KINSHASA | INGEROSEC CORPORATION, JAPON | DATE:                        | ECHELLE              | DATE | N°       |
|  |                                  |   |                              | PREPARE PAR:<br>VERIFIE PAR: | A1 1:200<br>A3 1:400 | 2009 | CG-BD-F7 |

# ROUTE D' ACCÈS (TYPE3)

PK0+000 - PK3+540

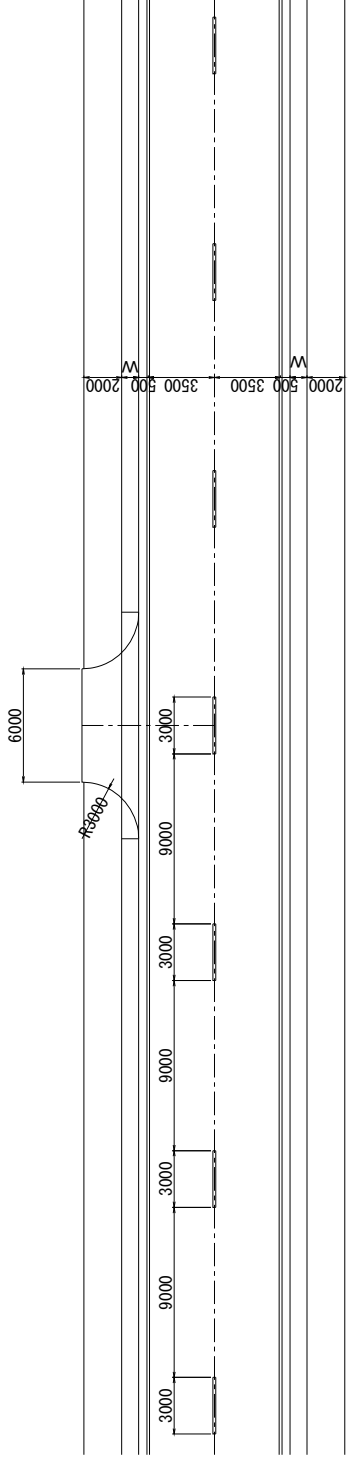

PK3+540 - PK10+330

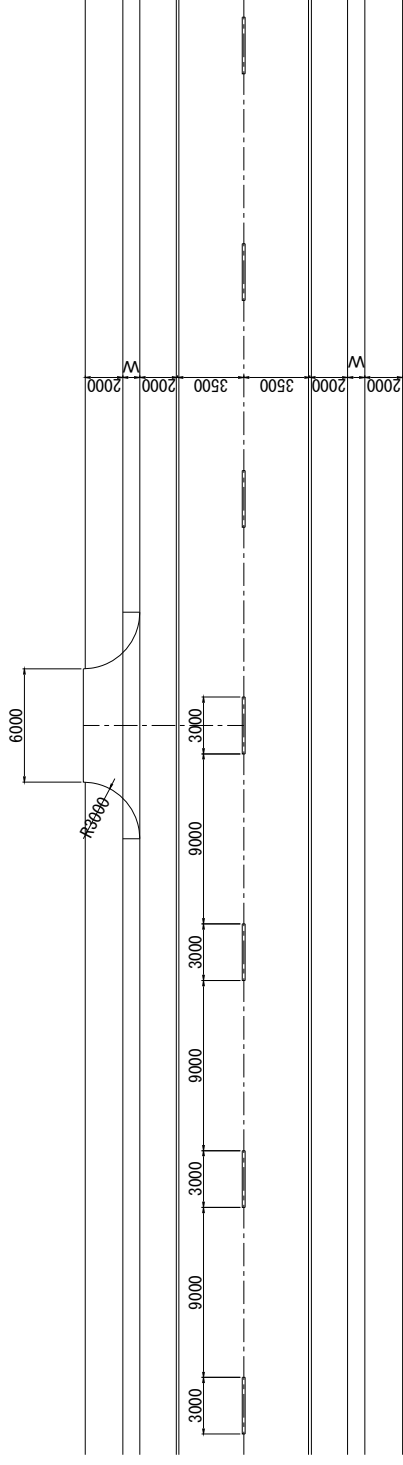

PROFIL EN TRAVERS ECHELLE A1 1:100  
A3 1:200

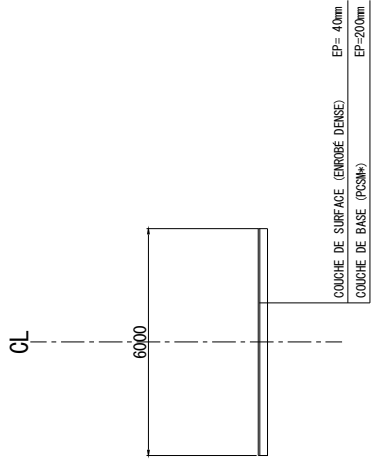

| PK | CG/CD | Remarks                   |
|----|-------|---------------------------|
| 1  | 0+140 | CG BIA                    |
| 2  | 0+490 | CG Sep CONGO              |
| 3  | 0+950 | CG                        |
| 4  | 1+340 | CG                        |
| 5  | 1+370 | CG Harbor Orgaman         |
| 6  | 1+405 | CG Factory Montage Toyota |
| 7  | 1+470 | CG Factory Montage Toyota |
| 8  | 1+515 | CG AMTO Frere             |
| 9  | 1+545 | CG AMTO Frere             |
| 10 | 1+595 | CG                        |
| 11 | 1+610 | CG Harbor TFCE            |
| 12 | 1+700 | CG ENTRIAC                |
| 13 | 1+740 | CG NOGUERA                |
| 14 | 1+750 | CG NOGUERA                |
| 15 | 1+790 | CG NOGUERA                |
| 16 | 1+820 | CG LOMATA                 |
| 17 | 1+850 | CG LOMATA                 |
| 18 | 1+900 | CG BATA                   |
| 19 | 1+970 | CG                        |
| 20 | 2+010 | CG                        |
| 21 | 2+080 | CG BCT                    |
| 22 | 2+145 | CG CTB                    |
| 23 | 2+160 | CG CTB                    |
| 24 | 2+200 | CG                        |
| 25 | 2+330 | CG                        |
| 26 | 2+450 | CG                        |
| 27 | 2+550 | CG                        |
| 28 | 2+725 | CG CEDICIM                |
| 29 | 2+770 | CG INTRAPLAST             |
| 30 | 2+875 | CG                        |
| 31 | 2+890 | CG AGETRAF                |
| 32 | 4+790 | CG New Langi              |
| 33 | 5+270 | CG Societe STICK          |
| 34 | 5+830 | CG Usin de peinture       |
| 35 | 5+940 | CG                        |

| PK | CG/CD  | Remarks         |
|----|--------|-----------------|
| 36 | 6+160  | CG              |
| 37 | 6+290  | CG IVECO        |
| 38 | 6+395  | CG              |
| 39 | 6+750  | CG UN Base      |
| 40 | 6+800  | CG Fuel Stand   |
| 41 | 6+930  | CG              |
| 42 | 7+025  | CG              |
| 43 | 7+050  | CG              |
| 44 | 7+120  | CG              |
| 45 | 7+785  | CG              |
| 46 | 8+585  | CG              |
| 47 | 8+765  | CG              |
| 48 | 8+930  | CG              |
| 49 | 9+560  | CG              |
| 50 | 9+670  | CG Atelier Bois |
| 51 | 9+780  | CG              |
| 52 | 9+870  | CG SAFRICAS     |
| 53 | 11+005 | CD              |
| 54 | 11+225 | CD              |
| 55 | 11+250 | CD              |
| 56 | 11+300 | CD              |
| 57 | 0+0    | CD              |
| 58 | 0+25   | CD              |
| 59 | 0+65   | CD              |
| 60 | 0+170  | CD              |
| 61 | 0+190  | CD              |

CG : Côté gauche  
CD : Côté droit

|  |                                  |   |                              |                              |                        |                                 |      |                |
|--|----------------------------------|---|------------------------------|------------------------------|------------------------|---------------------------------|------|----------------|
| AGENCE JAPONAISE DE COOPERATION INTERNATIONALE | REPUBLIQUE DEMOCRATIQUE DU CONGO | L'ETUDE PREPARATOIRE POUR LE PROJET DE REHABILITATION ET DE MODERNISATION DE L'AVENUE DES POIDS LOURDS A KINSHASA | INGEROSEC CORPORATION, JAPON | DATE:                        | ROUTE D' ACCÈS (TYPE3) | ECHELLE<br>A1 1:200<br>A3 1:400 | DATE | N°<br>CG-BD-F8 |
|  |                                  |   |                              | PREPARE PAR:<br>VERIFIE PAR: |                        |                                 | 2009 |                |

# GARDE BALISE

ECHELLE A1 1:20  
A3 1:40

## BALISE DE SÉ CURITÉ ROUTIÈRE      BALISE POUR PIÉTONS TYPE 1      BALISE POUR PIÉTONS TYPE 2

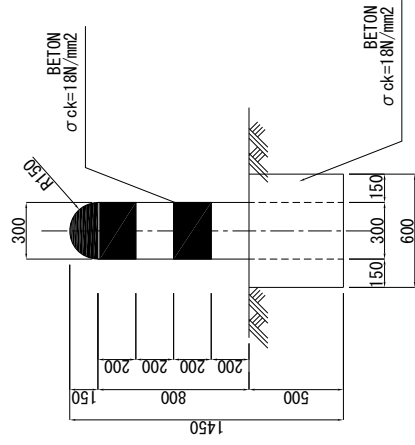

| PK              | CG/CD | Quantité |
|-----------------|-------|----------|
| 1 0+250 - 0+362 | CG    | 56       |
| 2 0+700 - 0+710 | CD    | 5        |

CG : Côté gauche  
CD : Côté droit

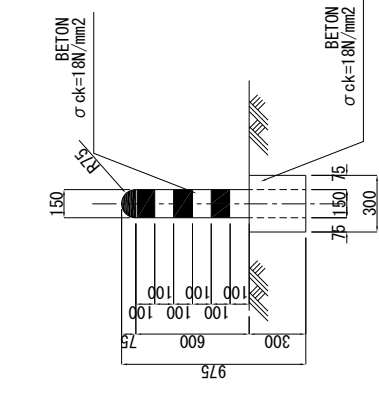

| PK        | CG/CD | Quantité |       |
|-----------|-------|----------|-------|
|           |       | Type1    | Type2 |
| 1 0+470   | CG/CD | 4        | 36    |
| 2 1+300   | CD    | 2        | 18    |
| 3 1+950   | CG/CD | 4        | 36    |
| 4 2+400   | CG    | 2        | 18    |
| 5 2+800   | CG/CD | 4        | 36    |
| 6 3+000   | CG/CD | 4        | 36    |
| 7 3+850   | CG/CD | 4        | 36    |
| 8 4+350   | CG/CD | 4        | 36    |
| 9 4+850   | CG/CD | 4        | 36    |
| 10 5+350  | CG/CD | 4        | 36    |
| 11 5+850  | CG/CD | 4        | 36    |
| 12 6+350  | CG/CD | 4        | 36    |
| 13 6+980  | CG/CD | 4        | 36    |
| 14 7+400  | CG/CD | 4        | 36    |
| 15 7+850  | CG/CD | 4        | 36    |
| 16 8+350  | CG/CD | 4        | 36    |
| 17 8+850  | CG/CD | 4        | 36    |
| 18 9+400  | CG/CD | 4        | 36    |
| 19 9+950  | CG/CD | 4        | 36    |
| 20 10+500 | CD    | 2        | 18    |

CG : Côté gauche  
CD : Côté droit

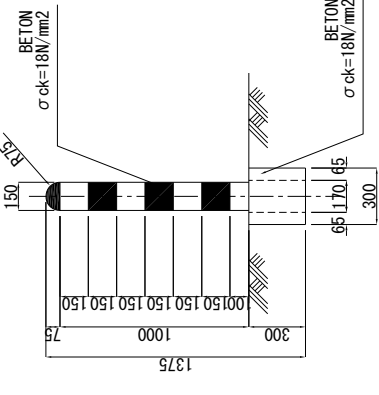

|  |                                  |   |                              |              |              |      |    |
|--|----------------------------------|---|------------------------------|--------------|--------------|------|----|
| AGENCE JAPONAISE DE COOPERATION INTERNATIONALE | REPUBLIQUE DEMOCRATIQUE DU CONGO | L'ETUDE PREPARATOIRE POUR LE PROJET DE REHABILITATION ET DE MODERNISATION DE L'AVENUE DES POIDS LOURDS A KINSHASA | INGEROSEC CORPORATION, JAPON | DATE:        | ECHELLE      | DATE | N° |
|  |                                  |   |                              | PREPARE PAR: |              |      |    |
|  |                                  |   |                              | VERIFIE PAR: | GARDE BALISE |      |    |

# PANNEAU DE SIGNALISATION (1)

ECHELLE A1 1:20  
A3 1:40

## PANNEAU DE SIGNALISATION

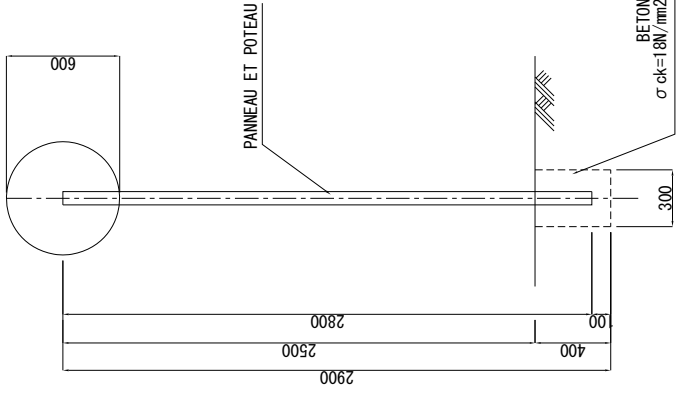

| A1a     | A1b     | A11a    | A22a    | A22b    | A27a    | B2a      | C6      | C14     | C21      | E9      | E13a     | E19     | E23     | D1a      |
|---------|---------|---------|---------|---------|---------|----------|---------|---------|----------|---------|----------|---------|---------|----------|
| 0+400CG | 0+080CD | 3+900CD | 1+370CG | 0+080CD | 0+400CD | 10+220CG | 2+830CD | 0+000CD | 0+370CD  | 5+670CG | 10+300CD | 1+690CD | 7+060CD | 11+150CD |
| 0+400CD |         | 4+200CG | 3+380CG | 0+400CG | 0+700CG | 2+950CG  | 2+830CG | 3+347CG | 0+570CG  |         |          | 2+020CD | 7+200CG | 0+300CG  |
| 0+840CG |         | 7+000CD | 3+700CG | 1+150CD | 1+920CD |          |         | 3+700CD | 1+200CD  |         |          | 2+270CD |         |          |
|         |         | 7+450CG |         | 7+870CD | 2+350CG |          |         | 4+200CG | 1+850CD  |         |          | 2+660CD |         |          |
|         |         | 7+700CD |         | 8+200CG | 7+400CD |          |         | 4+700CD | 2+050CG  |         |          | 3+317CD |         |          |
|         |         |         |         |         |         |          |         | 5+200CG | 2+500CG  |         |          | 3+347CG |         |          |
|         |         |         |         |         |         |          |         | 5+700CD | 2+700CD  |         |          | 3+980CD |         |          |
|         |         |         |         |         |         |          |         | 6+200CG | 2+900CG  |         |          | 4+010CG |         |          |
|         |         |         |         |         |         |          |         | 6+700CD | 2+900CD  |         |          | 4+725CG |         |          |
|         |         |         |         |         |         |          |         | 7+200CG | 3+100CG  |         |          | 4+725CD |         |          |
|         |         |         |         |         |         |          |         | 7+700CD | 3+750CD  |         |          | 5+705CD |         |          |
|         |         |         |         |         |         |          |         | 8+200CG | 3+950CG  |         |          | 6+470CG |         |          |
|         |         |         |         |         |         |          |         | 8+700CD | 4+250CD  |         |          | 6+470CD |         |          |
|         |         |         |         |         |         |          |         | 9+200CG | 4+450CG  |         |          | 7+320CG |         |          |
|         |         |         |         |         |         |          |         | 9+700CD | 4+750CD  |         |          | 7+320CD |         |          |
|         |         |         |         |         |         |          |         |         | 4+950CG  |         |          | 8+225CG |         |          |
|         |         |         |         |         |         |          |         |         | 5+250CD  |         |          | 8+225CD |         |          |
|         |         |         |         |         |         |          |         |         | 5+450CG  |         |          | 8+670CG |         |          |
|         |         |         |         |         |         |          |         |         | 5+750CD  |         |          | 8+670CD |         |          |
|         |         |         |         |         |         |          |         |         | 5+950CG  |         |          | 9+300CG |         |          |
|         |         |         |         |         |         |          |         |         | 6+250CD  |         |          | 9+300CD |         |          |
|         |         |         |         |         |         |          |         |         | 6+450CG  |         |          |         |         |          |
|         |         |         |         |         |         |          |         |         | 6+880CD  |         |          |         |         |          |
|         |         |         |         |         |         |          |         |         | 7+080CG  |         |          |         |         |          |
|         |         |         |         |         |         |          |         |         | 7+300CD  |         |          |         |         |          |
|         |         |         |         |         |         |          |         |         | 7+500CG  |         |          |         |         |          |
|         |         |         |         |         |         |          |         |         | 7+750CD  |         |          |         |         |          |
|         |         |         |         |         |         |          |         |         | 7+950CG  |         |          |         |         |          |
|         |         |         |         |         |         |          |         |         | 8+250CD  |         |          |         |         |          |
|         |         |         |         |         |         |          |         |         | 8+450CG  |         |          |         |         |          |
|         |         |         |         |         |         |          |         |         | 9+300CD  |         |          |         |         |          |
|         |         |         |         |         |         |          |         |         | 9+500CG  |         |          |         |         |          |
|         |         |         |         |         |         |          |         |         | 9+850CD  |         |          |         |         |          |
|         |         |         |         |         |         |          |         |         | 10+050CG |         |          |         |         |          |
|         |         |         |         |         |         |          |         |         | 10+400CD |         |          |         |         |          |

|  |                                  |   |                              |              |                              |          |      |    |
|--|----------------------------------|---|------------------------------|--------------|------------------------------|----------|------|----|
| AGENCE JAPONAISE DE COOPERATION INTERNATIONALE | REPUBLIQUE DEMOCRATIQUE DU CONGO | L'ETUDE PREPARATOIRE POUR LE PROJET DE REHABILITATION ET DE MODERNISATION DE L'AVENUE DES POIDS LOURDS A KINSHASA | INGEROSEC CORPORATION, JAPON | DATE:        | PANNEAU DE SIGNALISATION (1) | ECHELLE  | DATE | N° |
|  |                                  |   |                              | PREPARE PAR: |                              |          | 2009 |    |
|  |                                  |   |                              | VERIFIE PAR: |                              | COMME VU |      |    |



# PANNEAU DE SIGNALISATION (2)

ECHELLE A1 1:20  
A3 1:40

## BORNE KILOMETRIQUES

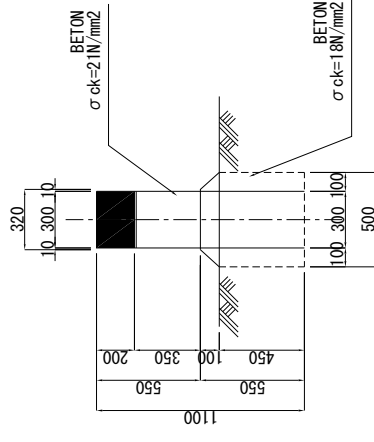
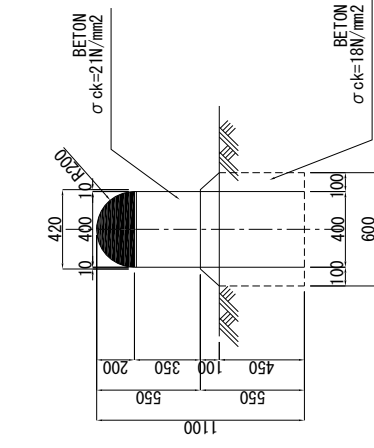

|   | PK      | Quantité |
|---|---------|----------|
| 1 | 0+000 - | 4        |
| 2 | 3+460 - | 5        |
| 3 | 7+940 - | 4        |

## PORTIQUE DE CALIBRAGE

ECHELLE A1 1:50  
A3 1:100

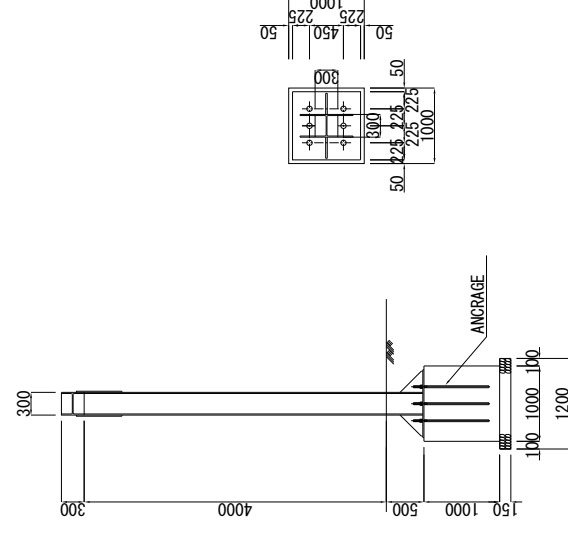
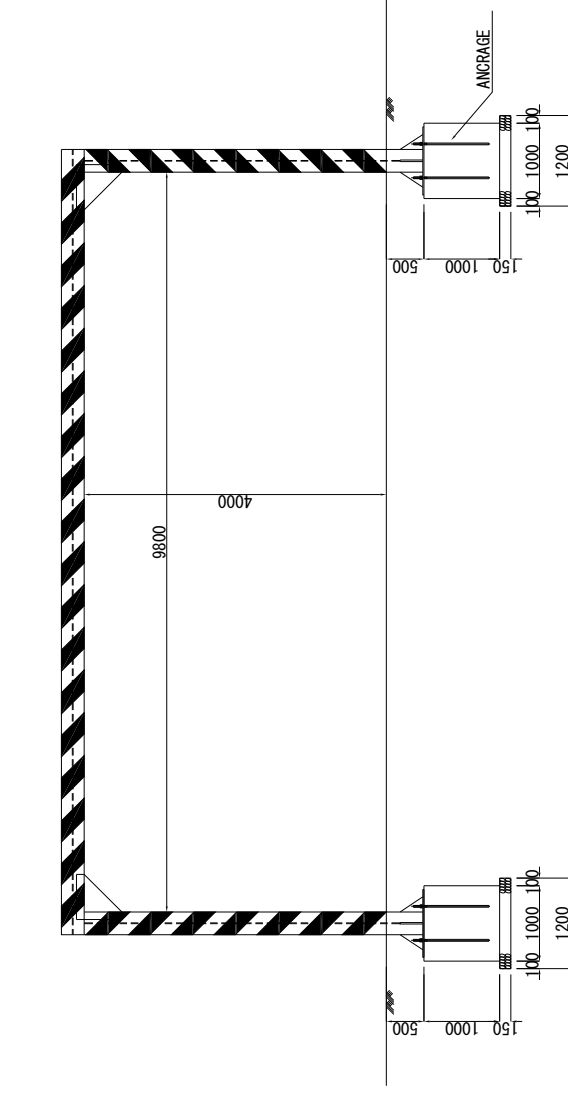

| PK | Quantité |
|----|----------|
| 1  | 2+880    |
| 2  | 2+910    |

AGENCE JAPONAISE DE  
COOPERATION INTERNATIONALE

REPUBLIQUE  
DEMOCRATIQUE DU CONGO

L'ETUDE PREPARATOIRE POUR  
LE PROJET DE REHABILITATION ET  
DE MODERNISATION DE L'AVENUE  
DES POIDS LOURDS A KINSHASA

INGEROSEC CORPORATION,  
JAPON

DATE:  
PREPARE PAR:  
VERIFIE PAR:

PANNEAU DE SIGNALISATION (2)

ECHELLE  
COMME VU

DATE

N°

2009

CG-BD-F11

# MARQUAGES AU SOL

ECHELLE A1 1: 50  
A3 1:100

## LIGNE EXTERIEURE



## LIGNE CENTRALE

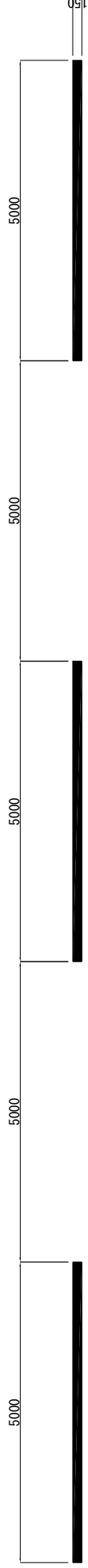

## BANDE D' ARRÊT

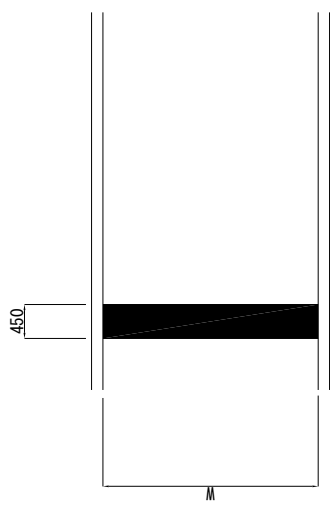

## PASSAGE PIETONS

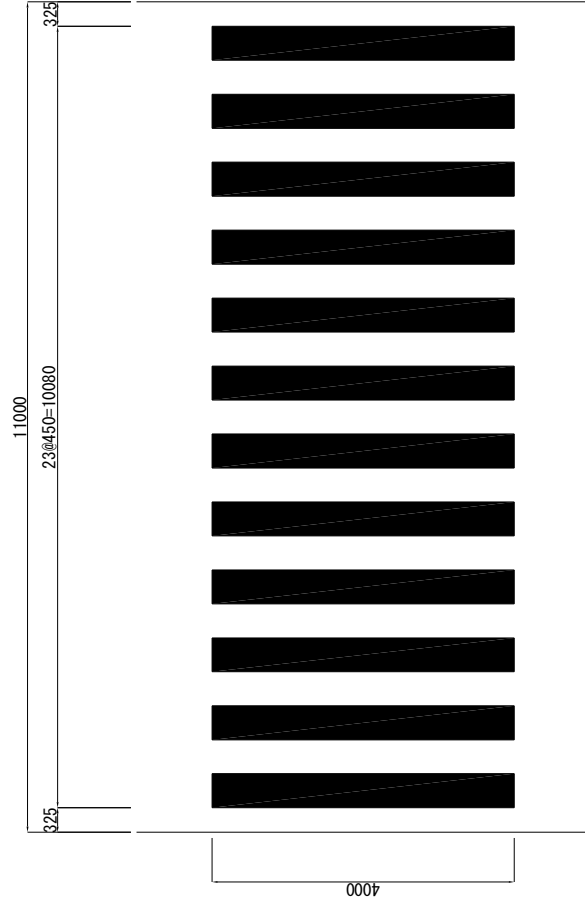

## ZEBRA

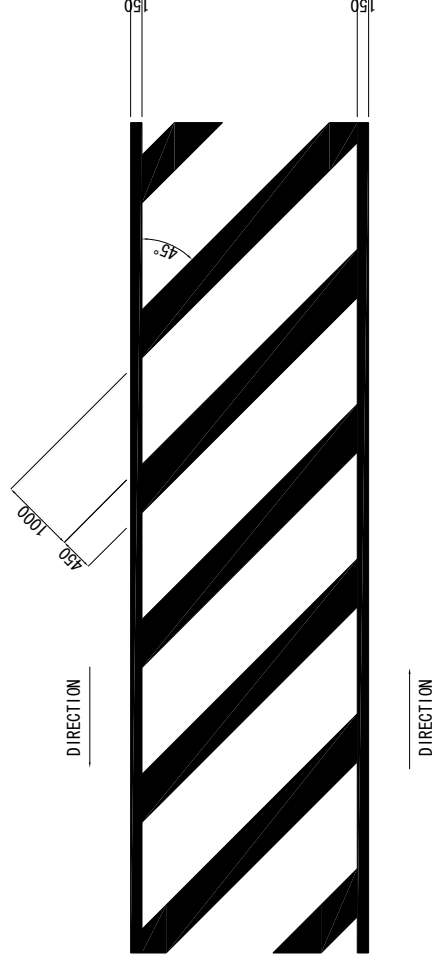

## FLECHES DE PRESIGNALISATION

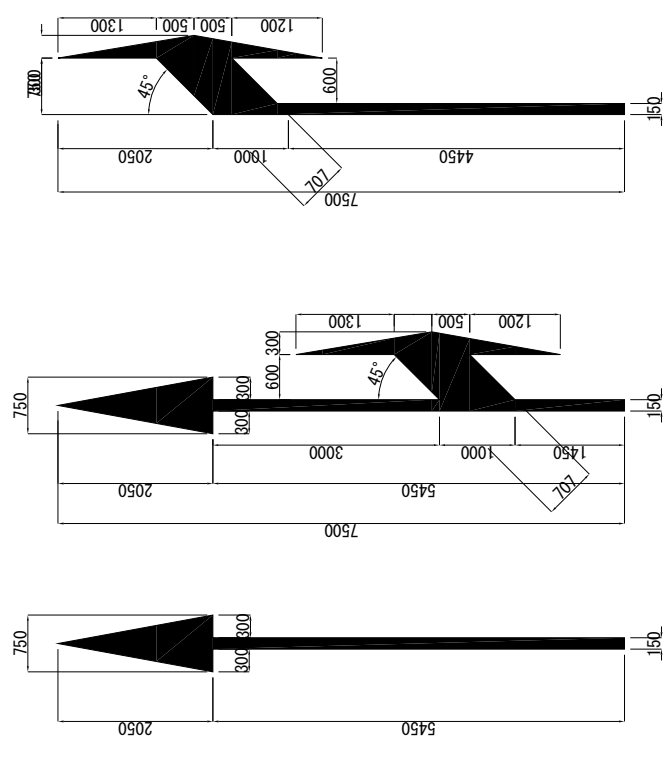

|  |                                  |   |                              |              |                  |         |      |    |
|--|----------------------------------|---|------------------------------|--------------|------------------|---------|------|----|
| AGENCE JAPONAISE DE COOPERATION INTERNATIONALE | REPUBLIQUE DEMOCRATIQUE DU CONGO | L'ETUDE PREPARATOIRE POUR LE PROJET DE REHABILITATION ET DE MODERNISATION DE L'AVENUE DES POIDS LOURDS A KINSHASA | INGEROSEC CORPORATION, JAPON | DATE:        | MARQUAGES AU SOL | ECHELLE | DATE | N° |
|  |                                  |   |                              | PREPARE PAR: |                  |         |      |    |
|  |                                  |   |                              | VERIFIE PAR: |                  |         |      |    |

# BORDURE

ECHELLE A1 1:20  
A3 1:40

# BLOC

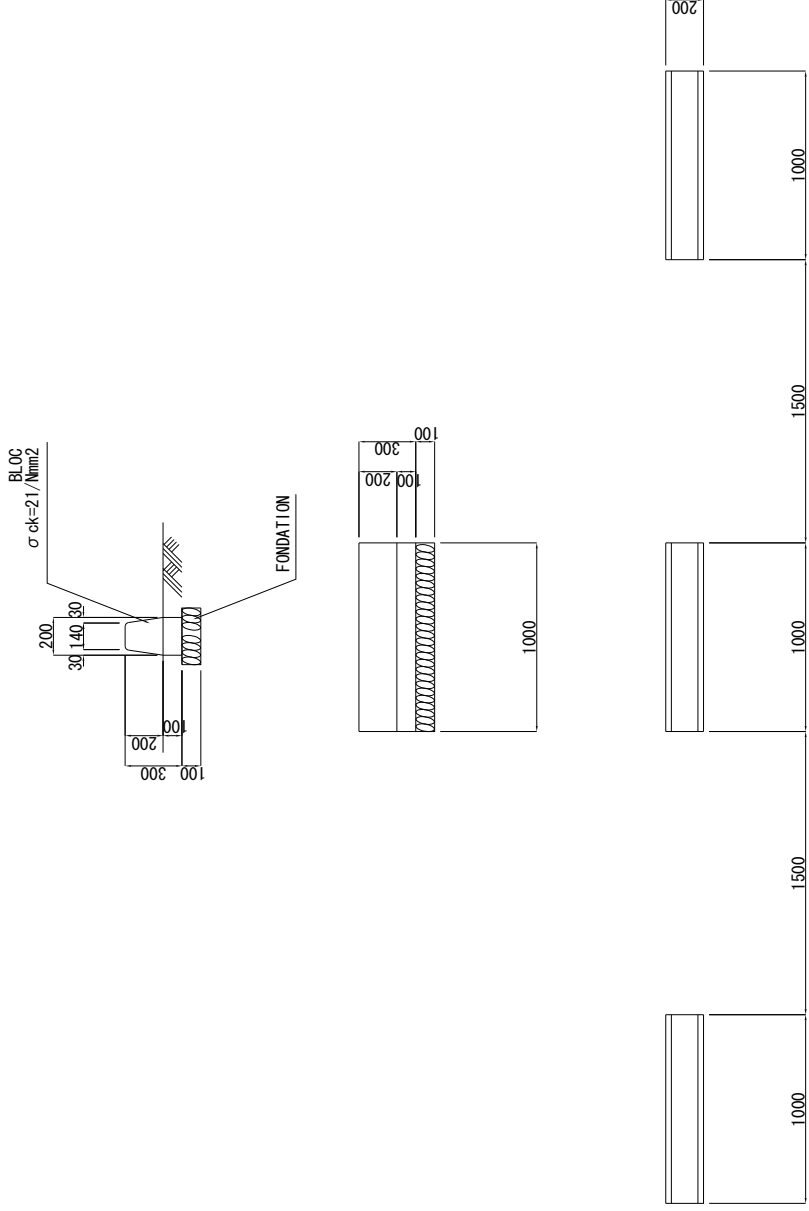

|  |                                  |   |                              |              |         |         |      |    |
|--|----------------------------------|---|------------------------------|--------------|---------|---------|------|----|
| AGENCE JAPONAISE DE COOPERATION INTERNATIONALE | REPUBLIQUE DEMOCRATIQUE DU CONGO | L'ETUDE PREPARATOIRE POUR LE PROJET DE REHABILITATION ET DE MODERNISATION DE L'AVENUE DES POIDS LOURDS A KINSHASA | INGEROSEC CORPORATION, JAPON | DATE:        | BORDURE | ECHELLE | DATE | N° |
|  |                                  |   |                              | PREPARE PAR: |         |         |      |    |
|  |                                  |   |                              | VERIFIE PAR: |         |         |      |    |

# SOUTÈNEMENT

ECHELLE A1 1:20  
A3 1:40

## SOUTÈNEMENT EN MACONNERIE

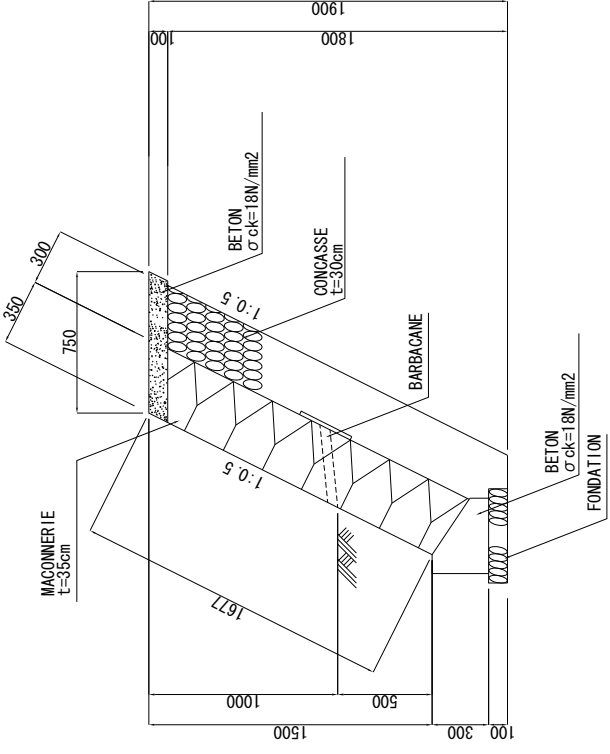

|   | PK     | Quantité(m) |
|---|--------|-------------|
| 1 | 10+100 | 5           |
| 2 | 10+125 | 5           |

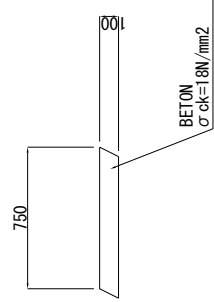
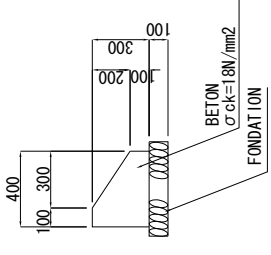

|  |                                  |   |                              |              |             |                     |      |    |
|--|----------------------------------|---|------------------------------|--------------|-------------|---------------------|------|----|
| AGENCE JAPONAISE DE COOPERATION INTERNATIONALE | REPUBLIQUE DEMOCRATIQUE DU CONGO | L'ETUDE PREPARATOIRE POUR LE PROJET DE REHABILITATION ET DE MODERNISATION DE L'AVENUE DES POIDS LOURDS A KINSHASA | INGEROSEC CORPORATION, JAPON | DATE:        | SOUTÈNEMENT | ECHELLE<br>COMME VU | DATE | N° |
|  |                                  |   |                              | PREPARE PAR: |             |                     | 2009 |    |
|  |                                  |   |                              | VERIFIE PAR: |             |                     |      |    |

# PLAN DU PASSAGE A NIVEAU (CARREFOUR DES FORCE NAVALE)

ECHELLE A1 - 1:50  
A3 - 1:100

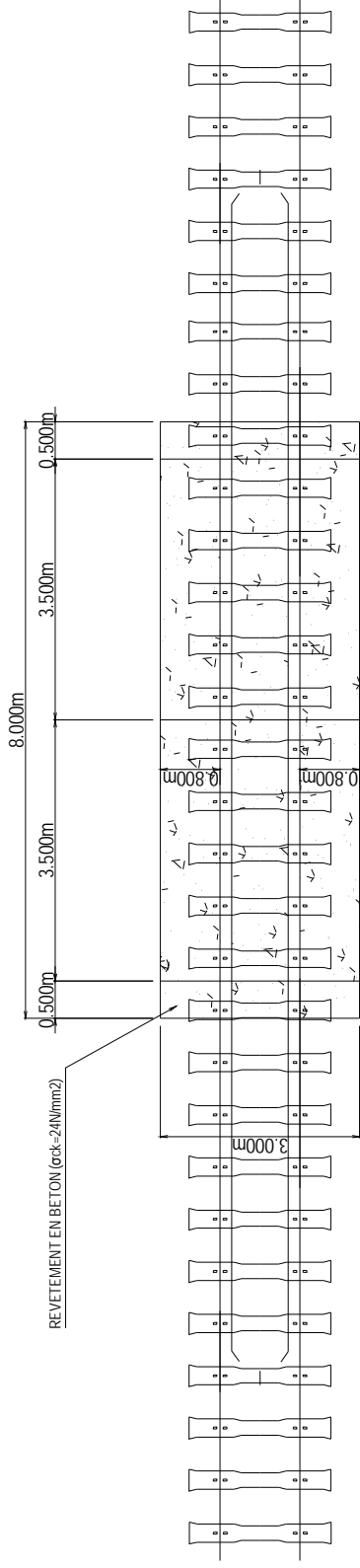

## DETAILS DU PASSAGE A NIVEAU

ECHELLE A1 - 1:10  
A3 - 1:20

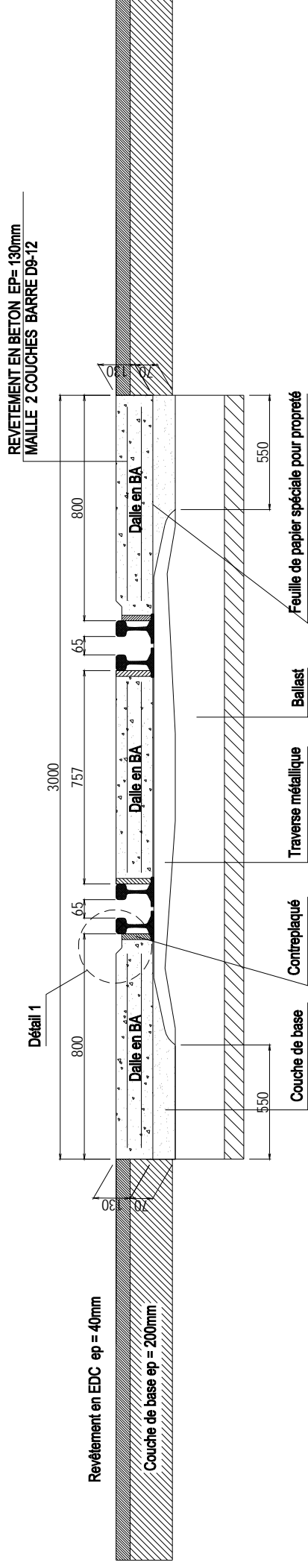

DETAIL 1

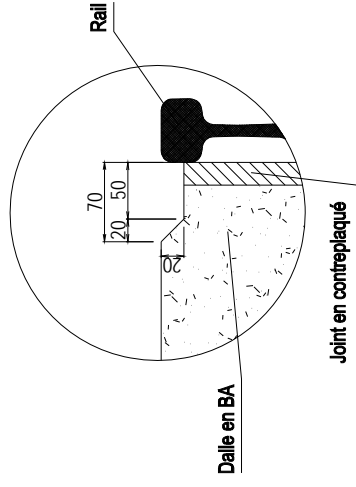

|  |                                  |   |                              |                              |  |         |           |    |
|--|----------------------------------|---|------------------------------|------------------------------|--|---------|-----------|----|
| AGENCE JAPONAISE DE COOPERATION INTERNATIONALE | REPUBLIQUE DEMOCRATIQUE DU CONGO | L'ETUDE PREPARATOIRE POUR LE PROJET DE REHABILITATION ET DE MODERNISATION DE L'AVENUE DES POIDS LOURDS A KINSHASA | INGEROSEC CORPORATION, JAPON | DATE:                        | DETAILS DU PASSAGE A NIVEAU (CARREFOUR DES FORCE NAVALE) | ECHELLE | DATE      | N° |
|  |                                  |   |                              | PREPARE PAR:<br>VERIFIE PAR: | COMME VU   | 2009    | CG-BD-F15 |    |

# PLAN DU PASSAGE A NIVEAU (CARREFOR DE LA 14<sup>ème</sup>RUE )

ECHELLE A1 - 1:50  
A3 - 1:100

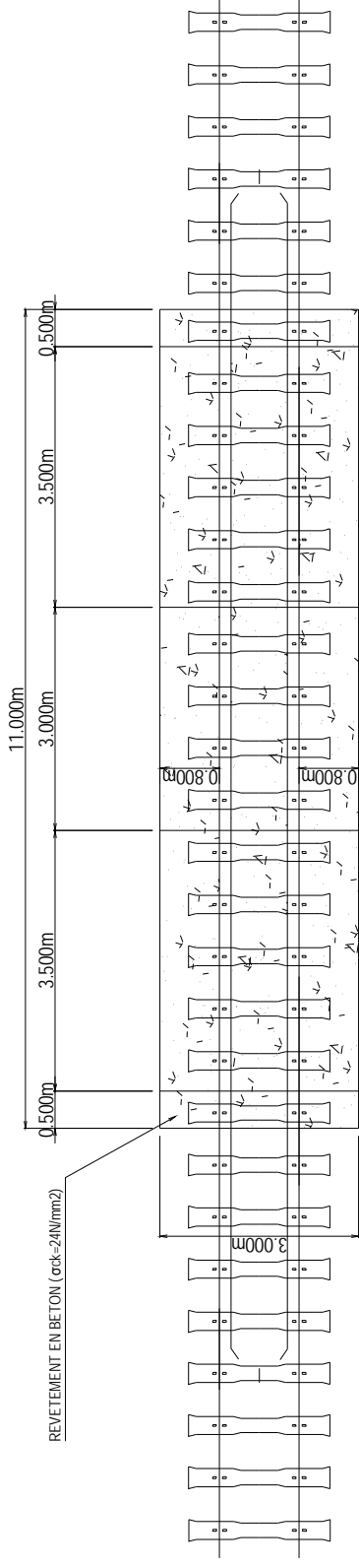

## DETAILS DU PASSAGE A NIVEAU

ECHELLE A1 - 1:10  
A3 - 1:20

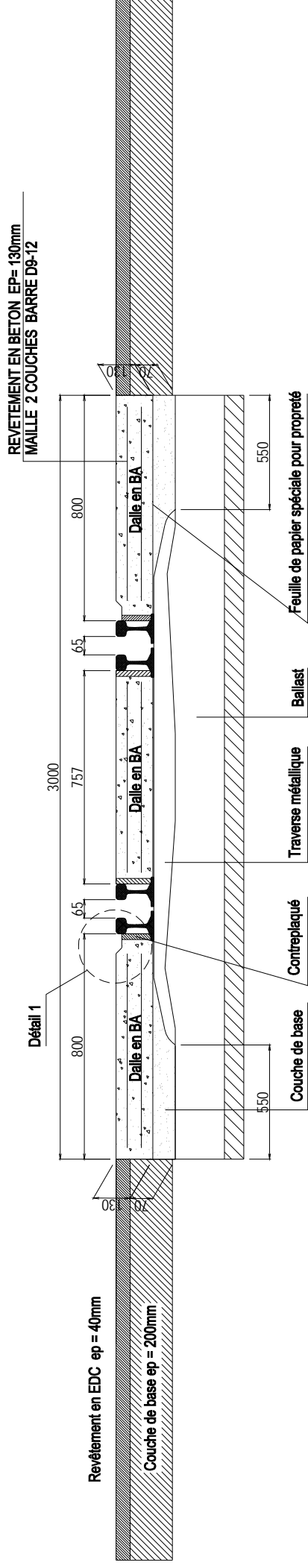

DETAIL 1

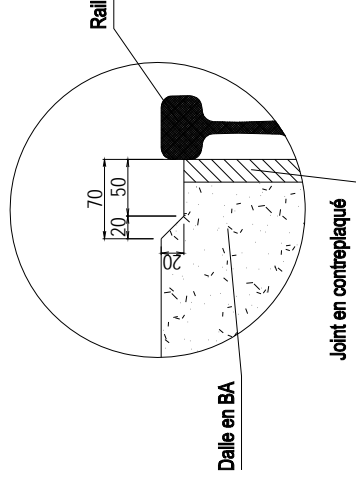

|  |                                  |   |                              |                              |  |         |           |    |
|--|----------------------------------|---|------------------------------|------------------------------|--|---------|-----------|----|
| AGENCE JAPONAISE DE COOPERATION INTERNATIONALE | REPUBLIQUE DEMOCRATIQUE DU CONGO | L'ETUDE PREPARATOIRE POUR LE PROJET DE REHABILITATION ET DE MODERNISATION DE L'AVENUE DES POIDS LOURDS A KINSHASA | INGEROSEC CORPORATION, JAPON | DATE:                        | DETAILS DU PASSAGE A NIVEAU (CARREFOR DE LA 14 <sup>ème</sup> RUE) | ECHELLE | DATE      | N° |
|  |                                  |   |                              | PREPARE PAR:<br>VERIFIE PAR: | COMME VU   | 2009    | CG-BD-F16 |    |