

**INITIAL ENVIRONMENTAL IMPACT
ASSESSMENT REPORT**

**DAMNAK AMPIL REHABILITATION
SUB-PROJECT
PURSAT RIVER BASIN
PURSAT PROVINCE**

December 2008

MINISTRY OF WATER RESOURCES AND METEOROLOGY
SUPPORTED BY JICA STUDY TEAM
ON
BASIN-WIDE BASIC IRRIGATION AND DRAINAGE MASTER PLAN

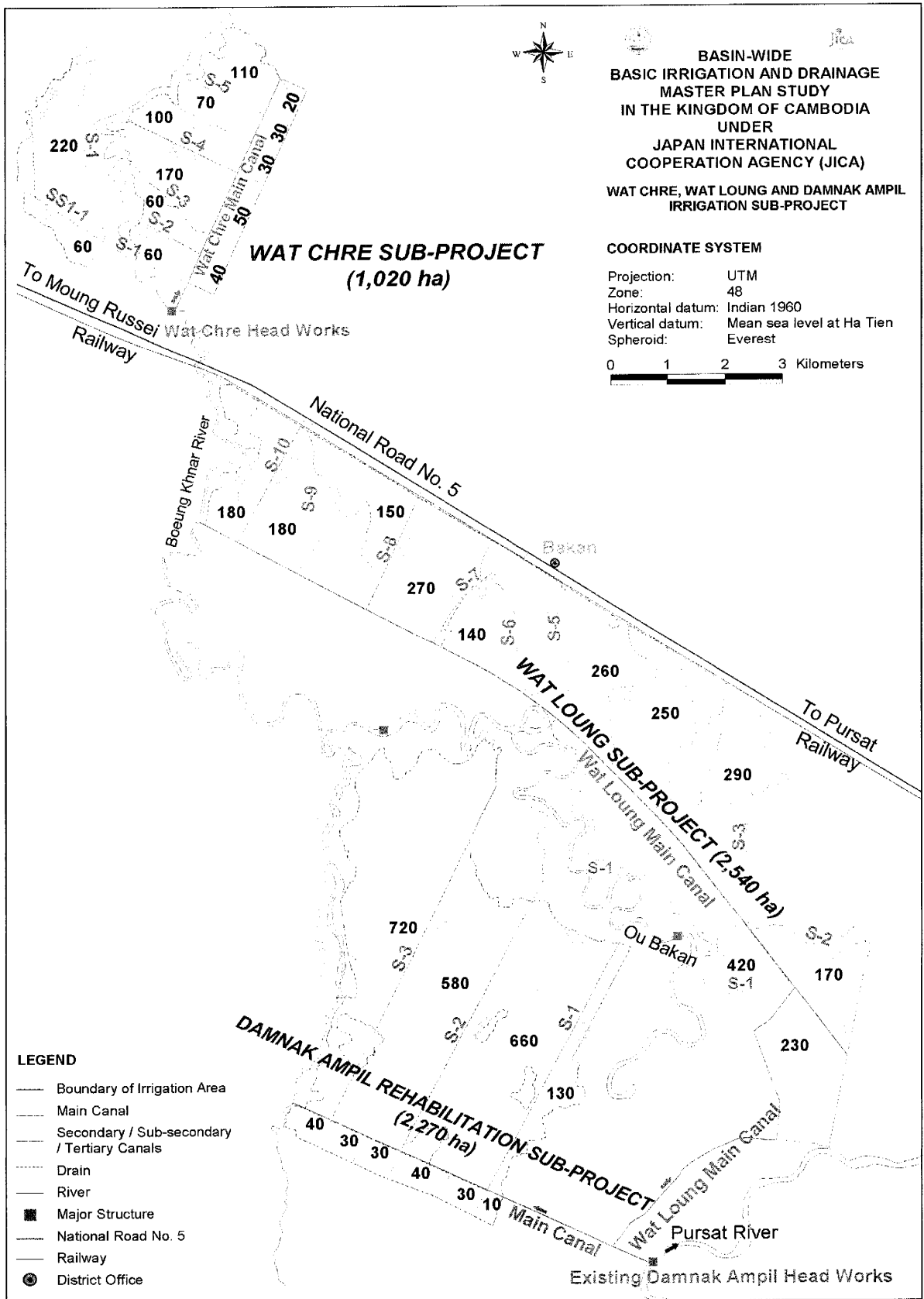

**Irrigation and Drainage Canal Layout of
Damnak Ampil, Wat Loung, and Wat Chre
Rehabilitation Sub-projects**

Environment-Related Features

Damnak Ampil Rehabilitation Sub-Project (Pursat River Basin)



Existing Damnak Ampil Headworks Originally Constructed by MOWRAM in 2006 (February 2nd 2008)



Check Gate on the Main Canal Constructed by MOWRAM in 2006 (February 2nd 2008)

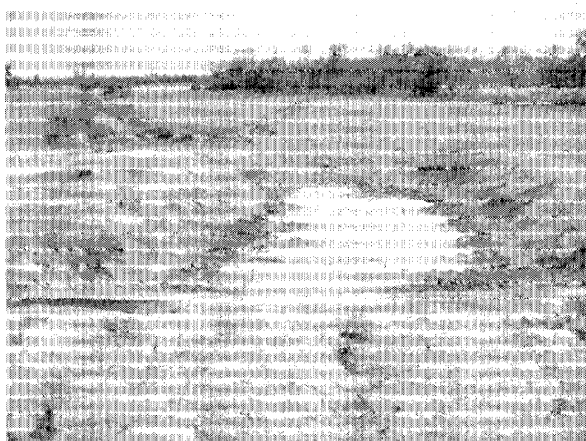

Secondary Canal to be Extended, not Developed at Present (February 2nd 2008)



Supplemental Irrigation Area with no Tertiary Canals Developed (February 2nd 2008)

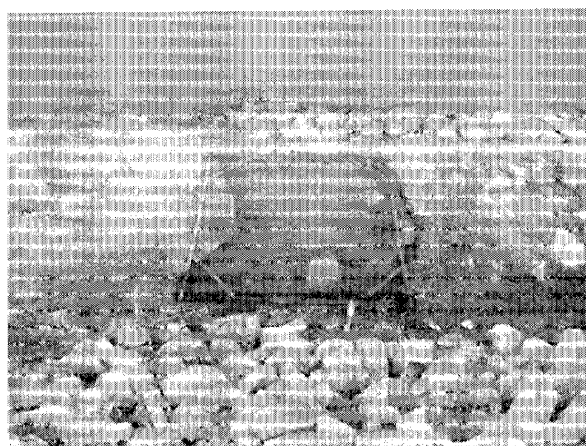

Fish Net Observed along the Main Canal utilized for Fish Farmers (February 2nd 2008)



Community-managed Forest along the Main Canal (February 2nd 2008)

Environment-Related Features Damnak Ampil Rehabilitation Sub-Project (Pursat River Basin)

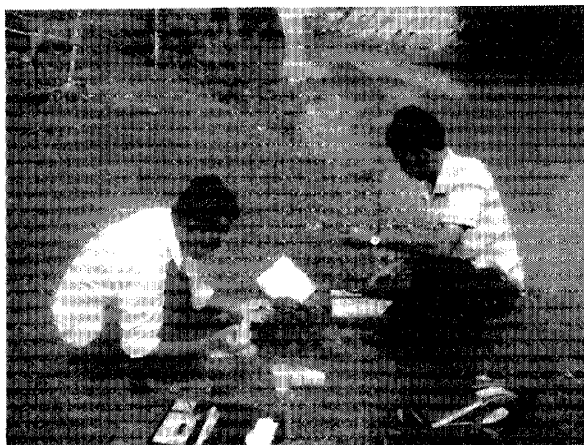

Water Quality Analysis for the Main Canal Water
(June 12th 2008)

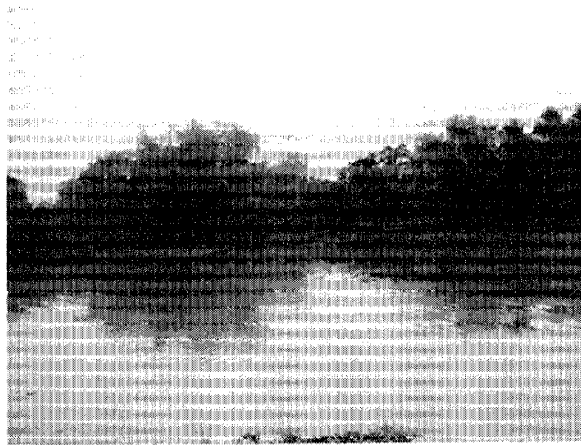

Water Stagnation due to Poor Drainage showing
Lower Level of pH
(June 12th 2008)

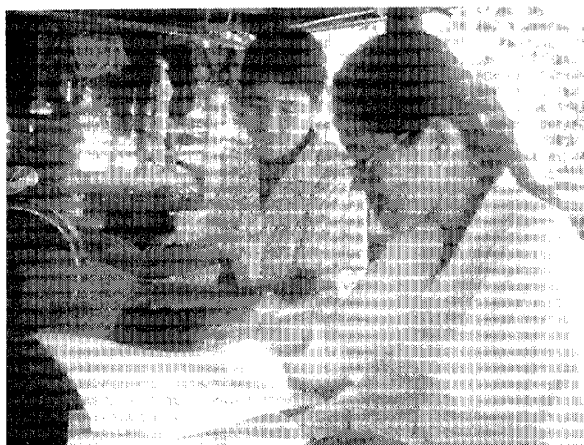

Socio-Economic Survey in the Commune to
Confirm Socio-Economic Conditions as well as
Environmental Constraints (May 30th 2008)

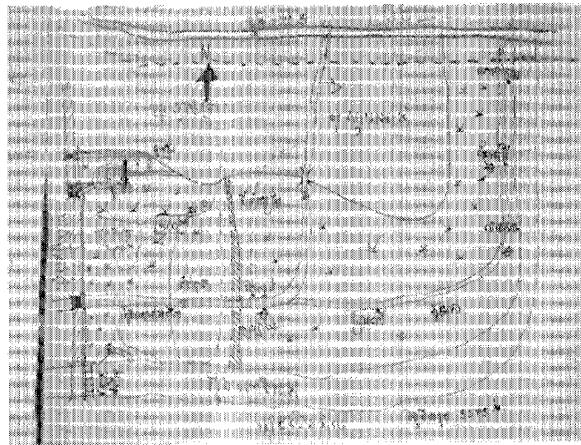

Resource Mapping prepared in the Public
Consultation Meeting by Representative Farmers
(January 31st 2008)



Institutional Linkage Mapping related with
Communities Activities including Environment by
Farmers (January 31st 2008)



Kiosk in the Village as One of the Income Source
of Villagers in addition to Agriculture
(February 2nd, 2008)

EXECUTIVE SUMMARY

Introduction

01. This Initial Environmental Examination Report (IEE Report) for Damnak Ampil Rehabilitation Sub-Project is prepared based on field reconnaissance, discussion with officials, consultation with farmers and quantitative data collected from relevant institutions. The report consist of: (i) environmental impact assessment system in Cambodia, (ii) methodology of IEE study applied, (iii) outline of proposed sub-project, (iv) present environmental conditions, (v) stakeholders' opinions, (vi) result of IEE, (vii) environmental management plan, (viii) comparison between "With" and "Without" conditions, (ix) institutional development plan and (x) conclusion.

Environmental Impact Assessment System in Cambodia

02. The Study has been carried out on the basis of relevant environmental laws and regulations including: (i) law on Environmental Protection and Natural Resource Management and Sub-Decrees, (ii) Environment-related Policies and Plans, (iii) land law and (iv) resettlement policy. Following figure shows procedure of environmental impact assessment stipulated in the Sub-Decree on Environmental Impact Assessment Process.

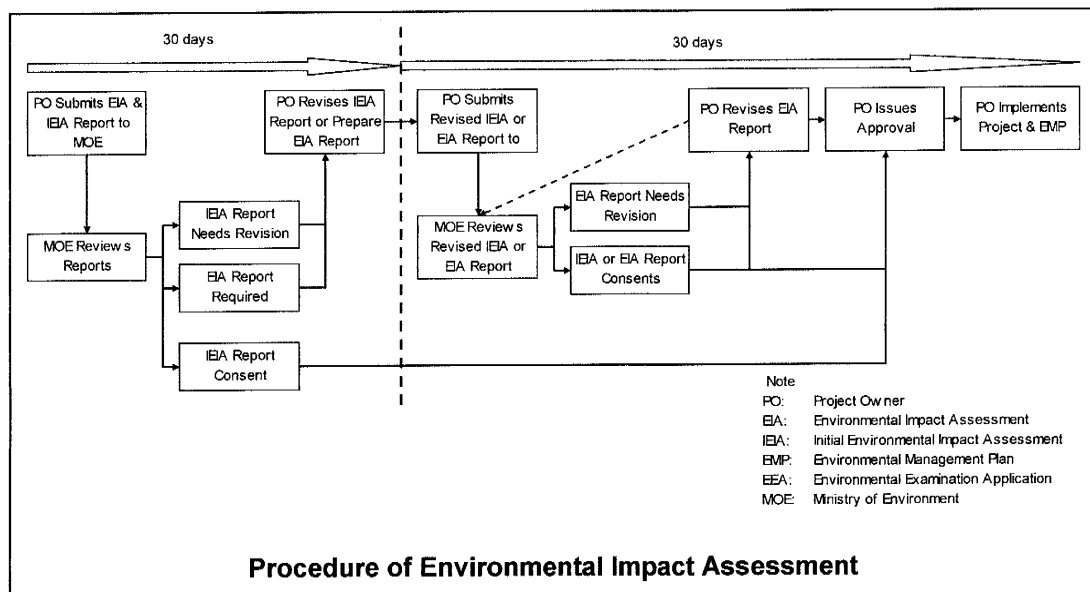

The Sub-Decree instructed that irrigation system with more than 5,000 ha needs IEE for the review and approval by the Ministry of Environment (MOE). Although target area of Damnak Ampil Sub-Project is 2,270 ha, IEE has been carried out through the discussion with relevant agencies assisted by JICA Study Team on Basin-Wide Basic Irrigation and Drainage Master Plan so as to ensure environment sustainability in and around the sub-project areas.

Methodology of IEE Study Applied

03. IEE was carried out through stakeholder consultation primarily consisting of: (i)

Interview Survey and (ii) environmental discussion in the workshop, (iii) field reconnaissance and (iv) analysis of existing data.

Outline of Proposed Sub-Project

04. Location and component of the Damnak Ampil Sub-Project is as follows:

Location of the Sub-Project

Item	Description		
1 Location	District	Commune	Village
	SamPovMeas	LorLokSar	DamNakAmPil
2 River basin/ water source	Pursat river basin/ Pursat river		
3 Target group	1) Number of household = 2,000 (Wet season medium- paddy) 2) Staff of PDOWRAM and PDA		
4 Objective of the project or program	Enhancement of rice production through rehabilitation of existing irrigation system		
5 Type of project or program	1) Improvement of existing automatic gate on Pursat River 2) Rehabilitation of existing irrigation system/ Construction of canals		
6 Objective area	2,270 ha		

The Damnak Ampil Sub-Project is located in Sam Pov Meas District in Pursat Province. Command area spread to 2,270 ha in total. Water is diverted from Pursat River by Damnak Ampil Headworks originally constructed by MOWRAM in 2006.

Irrigation and Drainage Rehabilitation Plan for Damnak Ampil Rehabilitation Sub-Project

No.	Description	Area and/or Number
1.	Sub-project area (ha)	2,270
	(Pump irrigation area included above)	(500)
2.	Annual irrigation area (Ha)	2,364
	- Early wet season paddy (Ha)	94
	- Medium wet season paddy (Ha)	2,270
	- Dry season paddy (Ha)	0
3.	Major water source	Pursat River
	- Name of headworks	Damnak Ampil (Existing)
	- Intake water level (EL. m)	17.00
	- Diversion water requirement at intake (m3/sec)	7.93
4.	Main canals (nos.)	1
	- Total length (km)	7.5
	- Capacity (m3/sec)	1.07 – 7.93
5.	Nos. of secondary canals	3
	- Total length (km)	17.6
	- Capacity (m3/sec)	0.98 – 1.07
6.	Number of Tertiary Blocks (No.)	50
	Total length of tertiary canals (km)	85
7.	Main drains	Ou Bakan / Boeung Khnar River
	- Total length (km)	-
	- Capacity (m3/sec)	Natural Stream
	- Drainage water requirement from paddy field (lit/sec/ha)	6.32
	- Drainage water requirement from other land (lit/sec/ha)	0.025~0.018
8.	Secondary drains (nos.)	4

No.	Description	Area and/or Number
	- Total length of secondary drains (km)	28.2
	- Capacity (m ³ /sec)	1.29 – 8.56
9.	Collector drains (nos.)	0
	- Total length of collector drain (New, km)	0
	- Capacity (m ³ /sec)	-

Prepared by JICA Study Team

Headworks and Major Facilities

Items	Description
- Improvement of Flood gate	Installation of new electric hoist: 7 sets Replacement of bushing: 7 sets
- Improvement of Scouring sluice gate	Replacement with electric hoist: 4 sets
- Construction of Fish Ladder	- width x height x length B:5.0m x H:4.6m x L:46m

Prepared by JICA Study Team

Present Environmental Conditions

05. Sub-project area is a farming community with the dominance of owner farmers. Average land holding is 1.2 ha. No historical and religious sites are there under the command area. Four protected areas: (i) Aural Wildlife Sanctuary, (ii) Phnom Samkos Wildlife Sanctuary, (iii) Tonle Sap Multiple Use Area and (iv) Cardamom Protected Forest situated in the Basin where sub-project is located. As for drinking and domestic water, farmers are largely dependant on tube pipe well. Since existing irrigation facilities particularly intake weir are significantly deteriorated, irrigation water is not provided from the system. Instead, farmers are largely dependent on rainfall and flood water especially in the wet season.

Stakeholder Opinions

06. During the field survey, the Study Team visited PDOWRAM, PDOE, and PDA to receive useful information for the sub-project. Workshop and public meeting shows that social environmental issues rather need to be considered. At present, cultivation and fish pond operation is carried out by farmers in the Pursat River and canal areas where it is stipulated as state property areas. Although farmers have really understood that such activities are drawn up before commencement of the construction works according to the discussion in the workshop, proper steps and mitigation measures are required for consensus building among relevant institutions and farmers.

Result of IEE

07. Sub-project components consist of: (i) rehabilitation of irrigation and drainage facilities, (ii) FWUC establishment and strengthening and (iii) agriculture support. Main subjects of FWUC establishment and strengthening and agriculture support are: (i) awareness program, (ii) module development, (iii) training and (iv) small-scale pilot exercise in agriculture and irrigation rehabilitation, therefore, adverse potential impact toward environment in and around the sub-project area is completely none or negligible or small.

Thus activities (ii) and (iii) are screened out from IEE. IEE in this report concentrates on potential impact from the rehabilitation of irrigation and drainage facilities. Potential negative environmental impacts are tabulated as follows:

Potential Negative Environmental Impact

Item		Stage		
		Preparation	Construction	O&M
Social Environment	Involuntary Resettlement	Land acquisition by the expansion and/or new construction of canals and drains (secondary and tertiary canals)	-	-
	Unequal Distribution of Damage and Benefit	Not all the communes under FWUC covered by the proposed command area	Not all the communes under FWUC covered by the proposed command area	Not all the communes under FWUC covered by the proposed command area
	Local Conflict Over Interest	-	Conflict among construction labors and farmers	Conflict over unequal water use
	Water Use	-	Reduction of drinking, domestic and irrigation water by river diversion	-
	Sanitation	-	Due to inflow of labors from outside	-
	Risk against Infectious Diseases	-	Due to inflow of labors from outside	-
Natural Environment	Coastal area such as Mangrove, Coral Reef and Tidal Area	-	-	Increase in chemicals and fertilizers application
	Flora, Fauna and Biodiversity	-	Disturbance of fish sprawling by construction works	Disturbance of fish sprawling by construction works
Pollution	Air Pollution	-	Emission gas from construction works	-
	Water Pollution	-	Waste water increase from construction works	Acceleration of nutrient load and/or chemical contamination in drainage water due to increase in chemicals and fertilizers application
	Soil Contamination	-	-	Misuse and/or excessive usage of chemicals and fertilizers
	Waste	-	Improper disposal of waste from	-

Item	Stage		
	Preparation	Construction	O&M
		construction works	
	Noise and vibration	-	Due to construction machinery -
	Accidents	-	Due to construction machinery -

Environmental Management Plan

08. Corresponding to the negative impact identified through IEE, seven mitigation measures are proposed as follows: (i) participatory land acquisition planning for main and secondary level facilities, (ii) participatory tertiary development for tertiary level facilities, (iii) education program for construction labor, (iv) construction of fish ladder, (v) environmental consideration in technical specification for construction works, (vi) System O&M and water management improvement and (vii) appropriate application of agricultural input, all of which are effective measures to alleviate environmental impact from the sub-project implementation. Among others, land acquisition is an important and a sensitive matter for irrigation project and the Damnak Ampil sub-project is not left out. It is recommended that mitigation measures be carried out as proposed so as to ensure sub-project sustainability from social environmental point of view.

Comparison between “With” and “Without” conditions

09. Comparison of conditions between “With” and “Without” conditions of the sub-project is made. Without implementing the Damnak Ampil sub-project, the livelihood of the people will most likely continue at their present levels. Each time the fertility of the plot of land comes to unproductive levels excessive intensity of production if future population pressure is considered. The implementation of the sub-project will mitigate the present instability in farming by providing irrigation water through rehabilitated facilities. It will make way for farming in more stabilized manner, improve living standards and provide additional income. It will gradually bring about a balance in resource use and reduce land degradation. Producing sufficient rice for domestic consumption is a priority policy of the government of Cambodia. Food security will be improved through increasing rice production which is one of the more important objectives of the sub-project.

Institutional Development Plan

10. In order to properly carry out EIA, prepare environmental management plan and pursue its implementation for irrigation development in the future, coordination is required between the Resettlement Unit under MOWRAM and EIA unit of MAFF. In addition, out-sourcing

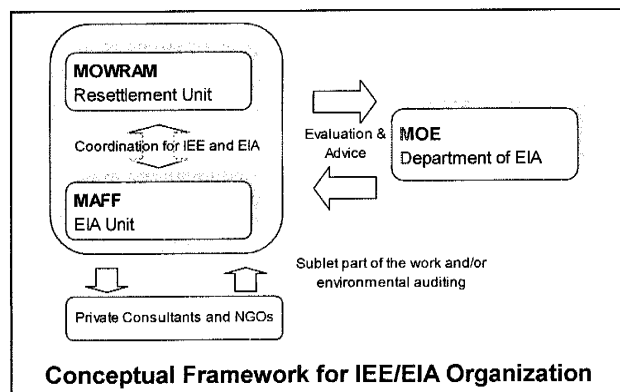

of the part of EIA work to private consulting firm should be also considered. Training programs proposed for environmental management is: (i) On-the-Job Training for IEE and Preparation of TOR for EIA and (ii) Training for Environmental Impact Mitigation and Management Planning.

Conclusion

11. It is concluded that the project will be extremely beneficial to the communities living in the sub-project areas. There will be better productivity and an improved livelihood if the project recommendations were to be implemented. No serious adverse environmental impacts are predicted since the sub-project is existing one and no large scale of expansion and/or new development is included. Those environmental impact identified are of a minor nature. Mitigation and enhancement measures are suggested where necessary and these will bring about an overall improvement in environmental quality. Indeed, once completed, well managed sub-project should enhance the long-term sustainability of the rural environment. In view of the above conclusions arising out of the IEE of the sub-projects, a full scale EIA is not considered necessary.

INITIAL ENVIRONMENTAL IMPACT ASSESSMENT REPORT

DAMNAK AMPIL REHABILITATION SUB-PROJECT

MINISTRY OF WATER RESOURCES AND METEOROLOGY
SUPPORTED BY JICA STUDY TEAM

ON

BASIN-WIDE BASIC IRRIGATION AND DRAINAGE MASTER PLAN

Sub-Project Layout
 Summary

Table of Contents

	<u>Page</u>
CHAPTER 1 INTRODUCTION	
1.1 General	1-1
1.2 Environmental Impact Assessment System	1-1
1.2.1 Environment Related Laws and Regulations	1-1
1.2 Screening of the Projects	1-8
CHAPTER 2 PROCESS OF ENVIRONMENTAL STUDY	
2.1 Interview Survey	2-1
2.2 Field Reconnaissance	2-2
CHAPTER 3 PROJECT BRIEF	
3.1 Background and Justification of the Project	3-1
3.2 Type, Size and Location of the Project	3-1
3.3 Project Component	3-3
CHAPTER 4 PRESENT ENVIRONMENTAL CONDITIONS OF THE PROJECT AREAS	
4.1 Physical Environment	4-1
4.1.1 Climate	4-1
4.1.2 Meteorology and Hydrology	4-1
4.1.3 Soils	4-2
4.1.4 Noise and Air Quality	4-3
4.1.5 Water Quality	4-3
4.2 Biological Environment	4-3
4.2.1 Vegetation and Land Use	4-3
4.2.2 Wild Life	4-4
4.2.3 Protected Areas	4-4
4.3 Social Environment	4-5
4.3.1 Population, Community and Ethnicity	4-5
4.3.2 Education	4-5
4.3.3 Health and Hazard	4-5
4.3.4 Historical and Religious Sites	4-6
4.3.5 Economic Condition	4-6
4.3.6 Present Water Use by Affected Communities	4-9

CHAPTER 5	STAKEHOLDERS OF THE PROJECT	
5.1	Local Authorities and Institutions Involved	5-1
5.2	Opinion of the Public Toward the Project	5-1
5.3	Present Environmental Issue	5-3
CHAPTER 6	INITIAL ENVIRONMENTAL EXAMINATION	
6.1	General	6-1
6.2	Potential Negative Environmental Impact.....	6-2
CHAPTER 7	ENVIRONMENTAL MANAGEMENT PLAN	
7.1	Environmental Impact Mitigation Measures	7-1
7.2	Environmental Management and Monitoring Plan	7-15
CHAPTER 8	COMPARISON BETWEEN WITH AND WITHOUT PROJECT	
8.1	Comparison Between “With” and “Without” Conditions.....	8-1
8.2	Comparison of Potential Negative Impacts Between “With” and “Without” Project	8-1
CHAPTER 9	STRENGTHENING OF INSTITUTIONAL CAPACITY FOR ENVIRONMENTAL MANAGEMENT	
9.1	Organizational Structure.....	9-1
9.2	Capacity Development Plan for Environmental Management	9-1
CHAPTER 10	CONCLUSIONS AND RECOMMENDATIONS	10-1

List of Tables

		<u>Page</u>
Table 4.3.1	Result of Poverty Ranking	T-1
Table 5.2.1	Summary of Discussion on PIMD made in the Public Meeting at Damnak Ampil Rehabilitation Sub-Project.....	T-2
Table 6.1.1	Environmental Impact Matrix of Damnak Ampil Rehabilitation Sub-Project (1/2-2/2).....	T-3

List of Figures

		<u>Page</u>
Figure 4.1.1	Soil Map of the Pursat River Basin.....	F-1
Figure 4.2.1	Protected Areas in the River Basin.....	F-2
Figure 5.1.1	Institutional Linkage Map of Lolok Sar Commune	F-3
Figure 5.1.2	Production-Marketing Flow Process of Lolok Sar Commune	F-4
Figure 5.1.3	Institutional Linkage Map of Snam Preah Commune	F-5
Figure 5.1.4	Production-Marketing Flow Process of Snam Preah Commune.....	F-6

List of Boxes

	<u>Page</u>
Box-1	
Subjects to be considered for environmental impact mitigation for the construction works	7-8

Abbreviations

ACLEDA	Association of Cambodian Local Economic Development Agencies
ADB	Asian Development Bank
AEA	Agro-Ecosystems Analysis
AEO	Agricultural Extension Offices
AEWs	Agricultural Extension Workers
ASEAN	Association of South East Asian Nations
B/C	Benefit-Cost Ratio
CARDI	Cambodian Agricultural Research and Development Institute
CC	Commune Council
CCF	Construction Conversion Factor
CDRI	Cambodia Development Research Institute
CDC	Council for Development of Cambodia
CEA	Cambodian Environment Association
CEC	Cation Exchange Capacity
CEDAC	Centre d'Etude de Development Agricole Cambodgien
CMAC	Cambodia Mine Action Center
CNMC	Cambodian National Mekong Committee
DAFF	Department of Agriculture, Forestry and Fisheries, MAFF
DAE	Department of Agriculture Extension
DAO	District Agricultural Office
DHRW	Department of Hydrology and River Works
ED	Engineering Department, MOWRAM
EDC	Electricite du Cambodia
EIA	Environmental Impact Assessment
EIRR	Economic Internal Rate of Return
EU	European Union
EXCOM	Executing Committee of SEILA
FAO	Food and Agriculture Organization of the United Nations
FFS	Farmer Field School
FG	Farmers Group
FO	Farmer Organization
F/S	Feasibility Study
FWUC	Farmer Water User Community
FWUG	Farmer Water User Group
GDP	Gross Domestic Product
GIS	Geographic Information System
GOC	Government of Cambodia
GOJ	Government of Japan
HH	Household
IEE	Initial Environmental Examination

IEAD	International Fund for Agricultural Development
IEIA	Initial Environmental Impact Assessment
IFAD	International Fund for Agricultural Development
ILO	International Labor Organization
IMF	International Monetary Fund
IMT	Irrigation Management Transfer
IO	International Organization
IPM	Integrated Pest Management
IRC	Inter-Ministerial Resettlement Committee
ISF	Irrigation Service Fee
JICA	Japan International Cooperation Agency
MAFF	Ministry of Agriculture, Forestry and Fisheries
M & E	Monitoring and Evaluation
MIS	Market Information System
MLMUPC	Ministry of Land Management, Urban Planning and Construction
MOE	Ministry of Environment
MOI	Ministry of Interior
MOWRAM	Ministry of Water Resources and Meteorology
M/P	Master Plan Study
MRC	Mekong River Commission
MRD	Ministry of Rural Development
NCCD	National Coordination Committee for Decentralization
NPRS	National Poverty Reduction Strategy
NGO	Non Government Organization
NEC	National Election Committee
O & M	Operation and Maintenance
PDA	Provincial Department of Agriculture
PDE	Provincial Department of Environment
PDLMUPC	Provincial Department of Land Management, Urban Planning and Construction
PDOWRAM	Provincial Department of Water Resources and Meteorology, MOWRAM
PIF	Provincial Investment Fund
PIMD	Participatory Irrigation Management and Development
PO	Project Owner
PRDC	Provincial Rural Development Committee
PRASAC II	Support Program for the Agricultural Sector in Cambodia
PSDD	Project to Support Democratic Development through Decentralization and Deconcentration
PMG	Project Management Group
RGC	Royal Government of Cambodia
RIP	Rural Road Improvement Program
RRA	Rapid Rural Appraisal
SEILA	Foundation Stone in Khmer: This word is used as national rural development program to 1- alleviate poverty and 2- Strengthen local governance and ownership of local government. (The Program ended in 2007)
SLPP	Smallholder Livestock Production Program
SPFS	Special Program for Food Security
SRI	System of Rice Intensification
TOT	Training of Trainers
UN	United Nations
UNDP	United Nations Development Program

UNICEF	United Nations Children’s Fund
UNTAC	United Nations Transitional Authority in Cambodia
UXO	Unexploded Ordnance
VAHW	Village Animal Health Worker Associations
VDC	Village Development Committee
VEW	Village Extension Worker
VLA	Village Livestock Agent
WFP	World Food Program
WMO	World Meteorological Organization
WUG	Water User Group
DOM	Department of Meteorology
DHRW	Department of Hydrology and River Works
TSC	Technical Service Center
PDOWRAM	Provincial Department of Water Resources and Meteorology
MRC	Mekong River Commission

Khmer Words Used in the Report

Khet	Province
Srok	District
Khum	Commune
Phum	Village
Krom	Group or Sub-Group
Krom Samik	Solidarity Group
Provasdai	Mutual Help

INITIAL ENVIRONMENTAL IMPACT ASSESSMENT REPORT DAMNAK AMPIL REHABILITATION SUB-PROJECT

CHAPTER 1 INTRODUCTION

1.1 General

This is an Initial Environmental Impact Assessment (IEIA) Report of Damnak Ampil Rehabilitation Sub-Project prepared on the basis environmental assessment-related regulations, sub-decree and guidelines of Cambodia. The Report describes the environmental assessment system in Cambodia, the present environmental condition, result of the environmental assessment, and environmental management plan of Damnak Ampil Sub-Project. Field reconnaissance was carried out to grasp the natural and social condition of the site.

It shall be noted that in this Pre-Feasibility Study, an emphasis has been given to minimize the probable adverse environmental impacts from natural and social view points in the course of the plan formulation process. In this Report, Chapter 1 describes environmental impact assessment system in Cambodia including environmental laws and regulations, which are the basis of all the environmental assessment under this Report. Project screening is also mentioned in the Chapter. Chapter 2 is the methodology of environmental study applied. From Chapter 3 to Chapter 5, outline of proposed sub-project together with environmental conditions and stakeholders' opinion is delineated.

On the basis of proposed project component, an IEIA is carried out as described in Chapter 6. Chapter 7 shows mitigation measures and environmental monitoring plan corresponding to the impacts identified in the previous chapter. Chapter 8 covers comparison between "with-project-condition" and "without-project-condition" from natural and social aspects. In order to establish workable environmental monitoring and evaluation set-up, institutional development plan is prepared in Chapter 9 so as to contribute to sustainable irrigation development in Damnak Ampil Irrigation Sub-Project. Chapter 10 finally provides overall conclusions of IEIA.

1.2 Environmental Impact Assessment System

1.2.1 Environment Related Laws and Regulations

(1) List of Laws and Regulations

In the 1990s, the Government of Cambodia enacted several key pieces of environment related laws and regulations to establish the legal framework of environmental management. The Ministry of Environment (MOE), established in 1993, is the key agency responsible for environmental management and natural resource conservation. MOE's strategy is on the basis on the execution of both sole and joint responsibilities since environmental management is interdisciplinary and cross-sectoral issues requiring close inter-coordination. MOWRAM and

MAFF also have been playing an important role in environmental management related with irrigated agriculture development in collaboration with MOE.

Relevant laws and regulations with those provisions are summarized as follows:

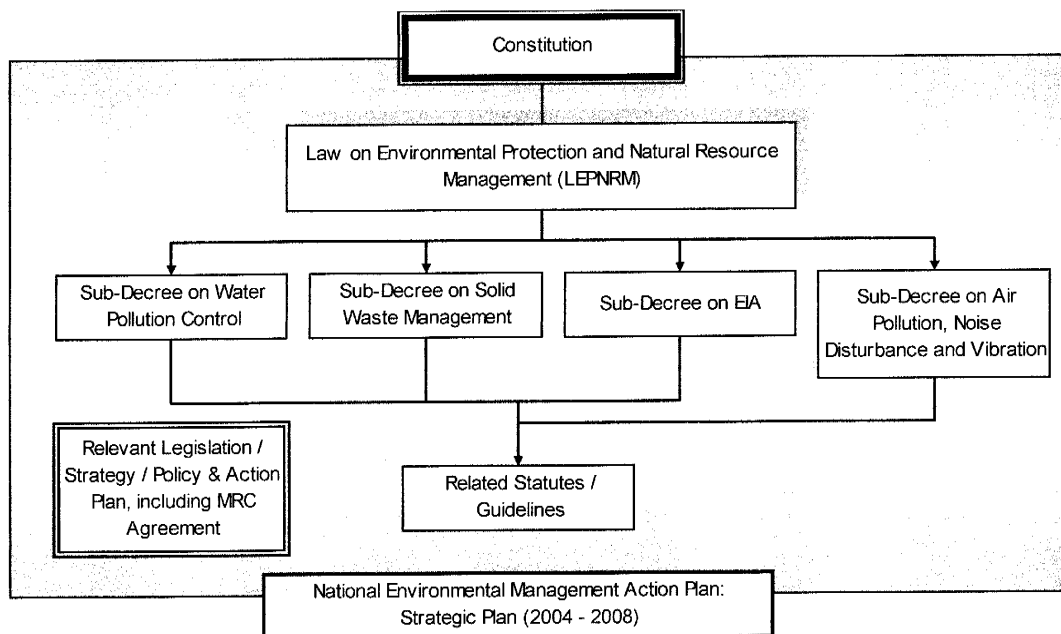

Prepared by JICA Study Team

Legislative Framework in Environmental Protection and Management

(i) Law on Environmental Protection and Natural Resource Management and Sub-Decrees

Under the Constitution, Law on Environmental Protection and Natural Resource Management (LEPNRM) was enacted in 1996, which is the supreme legal instrument controlling environmental protection and natural resource management in the country. The salient feature of LEPNRM is: (i) to protect and promote environmental quality and public health, (ii) to assess the environmental impact of all proposed projects, (iii) to encourage and enable the public to participate in environmental protection, and natural resource management and (iv) to suppress any act that cause harm to the environment. In order to ensure the contents of LEPNRM and supplement for environmental management in practice, four Sub-Decrees have been issued: (i) Sub-Decree on Environmental Impact Assessment Process (1999), (ii) Sub-Decree on Water Pollution Control (1999), (iii) Sub-Decree on Solid Waste Management (1999) and (iv) Sub-Decree on Air Pollution and Noise Disturbance (2000).

(ii) Environment-related Policies and Plans

In terms of environmental management policy, MOE together with line-agencies has prepared National Environmental Action Plan (NEAP) and has been regularly updating Strategic Plan based on the above-explained set of laws and decrees, summary of which are tabulated as follows:

Relevant Environmental Management Policy and Plans

Title	Contents
National Environmental Action Plan	It was firstly prepared by MOE in 1998 with the assistance from World Bank, UNDP, USAID and DANIDA and approved by the Council of Ministries in 1998. It aimed at integrating environmental concerns into national and local development policies, economic decisions making, and investment planning particularly focusing on forest policy, fisheries and floodplain agriculture in Tonle Sap Region, coastal fisheries and so forth.
The Five Year Socio-Economic Development Plan (1996-2000)	It emphasized on conservation, protection and management of country's natural resources and environment in an ecologically sustainable manner outlining long-term management strategies for forest and protected areas, coastal zone, Tonle Sap Great Lake ecosystem, fisheries, water quality, and urban and community environment improvements.
The Second Five Year Socio-Economic Development Plan (2001-2005)	It focuses on social and economic development in rural areas, basic human needs, and poverty alleviation. The plan emphasizes on implementation of natural resource preservation and environmental protection programs particularly in rural areas.
Land Policy 2001	The objective is to ensure that land and natural resources are used in an equitable, sustainable and efficient manner. The Government has set a number of medium term objectives including forest concession management, reduction in urban and industrial pollution, strengthening protected area management, improving management of Tonle Sap ecosystems, and building the environment planning capacity.
Strategic Plan	<p><u>The First Three-Year Strategic Plan (1998 -2000)</u> It was prepared by reviewing all sectors activities including economy, society, culture, infrastructures, and environmental protection. Socio-development was started to be focused which gives adverse impact in environment.</p> <p><u>The Second Three-Year Strategic Plan (2001 – 2003)</u> Awareness on environmental protection was getting to be matured with the understanding that environmental management is consecutive action based on previous lessons. Importance on MOEs' capacity development was also emphasized for sustainable development in any sectors.</p> <p><u>The Third Five-Year Strategic Plan (2004 – 2008)</u> The latest plan prepared in 2003 emphasizes following issues: (i) inter-sectoral coordination within MOE as well as other Ministries, and (ii) public participation in environmental management.</p>

Source: Asian Development Bank (ADB) (2003), Compendium on Environment Statistics 2003 Cambodia
Ministry of Environment (MOE) (2003), Strategic Plan 2004 – 2008

(iii) Development Activities in the Protected Areas

Declaration No. 1033 on Protected Areas (1994) prohibits the following activities in order to conserve those areas:

- Construction of the saw mills, charcoal ovens, brick kilns, tile kilns, limestone ovens, tobacco ovens (Article 1)
- hunt or the placement of hunting traps, the fishing of mammals, amphibians, reptiles and aquatic animals for tusks, bones, feathers, horns, leathers and blood (Article 2)
- Deforestation for land use (Article 3)
- Exploitation of minerals and the use of explosives (Articles 4)
- Bringing of the domestic animals such as dogs (Article 5)

- Water pollution activities such as the use of explosives, poisons, chemicals, electricity and dumping waste into the water surface or onto the land (Article 6)
- Use of machineries and heavy cars which could cause smoke pollution, and use of microphones which could cause noise pollution (Articles 7)

The Article 8 of the Declaration stipulated that *researchers and experiments in protected areas shall be approved by the Ministry of Environment*. Although there are no irrigation systems to be developed in the protected areas, monitoring particularly water quality in the downstream of the system would be required to give adverse environmental impact toward protected areas.

(3) Land Policy and Legal Framework

(i) Land Law

The new Land Law, passed in August 2001, incorporates a number of significant changes and enhancement from previous Land Law 1992. The new Law consists of eight articles shown on the right:

The Law deals with ownership, property rights and compensation which are needs to be considered for irrigation and drainage development. According to the law, state properties are defined as such facilities as social infrastructures involving its land and natural origins, forest, rivers, protected areas and so forth.

Land Law 2001	
General Provisions	
Article 1	Private and Public Ownership
Article 2	Acquisition of Ownership
Article 3	The Regime of Private Ownership
Article 4	The Forms of Ownership
Article 5	Immovable Property Used as Surety
Article 6	Cadastre
Article 7	Penalty Provisions
Articles 8	Final Provisions
Source:	MLMUPC (2002)

This issue can be also supplemented by the Law on Water Resources Management that the beds and banks of rivers, streams, lakes, canals, and reservoirs are owned by the State.

(ii) Land Tenure and Land Registration

Land tenure and registration is not clear at present including agriculture sector. Land distribution particularly in rural areas has been carried out through the *Krom Samiki* (Solidarity Group under community) system. While lands were allocated and private ownership of plots recognized, no clear demarcation was officially made. Since new Land Law 2001 enacted, Ministry of land Management, Urban Planning and Construction (MLMUPC) is the sole institution in charge of land registration, however, understanding in the rural level is still in challenging and customary land tenure is in majority.

(iii) Resettlement Policy

There are no stipulated official documents at present, however, in the irrigation sector, it used to be not compulsory for the Government to compensate farmers land for tertiary development while compensation is supposed to be made to farmers for main and secondary facilities development in irrigation systems with the responsibility of Inter-Ministerial Resettlement Committee (IRC). Resettlement Unit under MOWRAM is currently drafting sub-decree and

guideline on the basis of ADB resettlement policy in order for smooth consensus building and resettlement among stakeholders as shown right.

ADB policy in resettlement¹ emphasized, on the other hand, following points:

- People affected should be at least as well off after resettlement as they were before;
- Social preparation is an important process for reducing tension and obtaining cooperation;
- People affected temporarily are counted and must be compensated and assisted accordingly; and
- All affected persons, including those without title to land, must be compensated for all their losses at replacement cost.

Sub-Decree on Addressing Socio-Economic Impacts caused by Development Projects	
Chapter 1	General Provisions
Chapter 2	General Public Interest and National Interest
Chapter 3	General Principles and Requirements
Chapter 4	Procedure for Determining Specific Nature of a Proposed Project
Chapter 5	Planning to Address Project Social Impacts
Chapter 6	Compensation and Rehabilitation Assistance
Chapter 7	Complaints and Judicial Review
Chapter 8	Budget
Chapter 9	Institutional Arrangements
Chapter 10	Final Provisions
Source: MOWRAM (2007)	

Until now in Cambodia, resettlement matter in irrigation and drainage development is generally dealt with by each project in accordance with the donors' policy and guidelines such as ADB's.

(4) Process of Environmental Impact Assessment

Procedure of EIA is stipulated in the Sub-decree on Environmental Impact Assessment Process enacted in 1999. The decree deals with institutional responsibilities, environmental impact assessment requirements necessary for proposed projects, EIA process for different type of projects and penalties. In addition, list of project with its scale is defined necessary for IEIA or EIA. Within MOE, Department of EIA under Technical General is responsible for the review and the assessment of IEIA and EIA report submitted from Project Owners (POs).

IEIA and EIA process are depicted below, description of which is given afterward:

¹ Asian Development Bank (ADB) (1998), Summary of the Handbook on Resettlement, A Guide to Good Practice

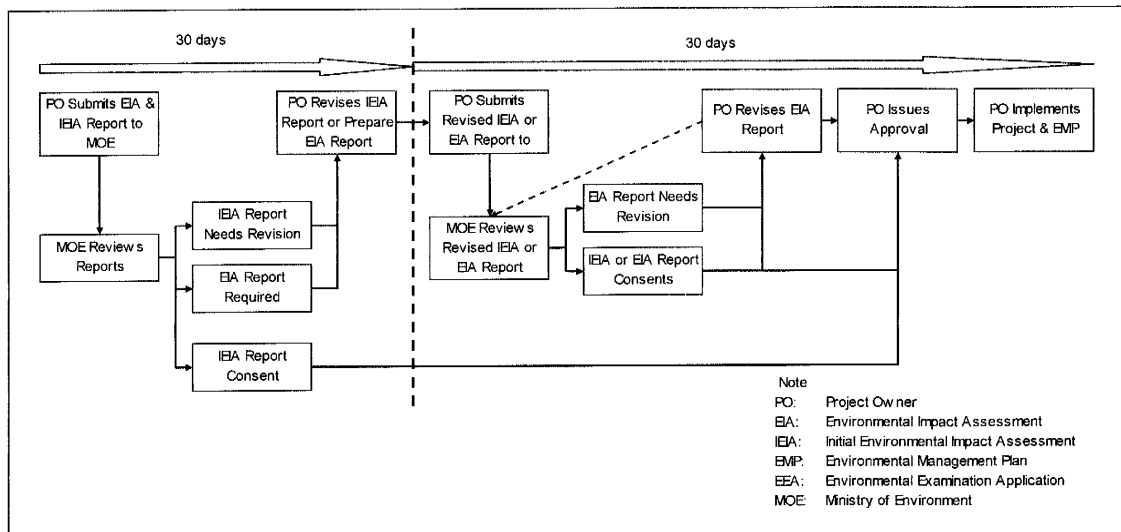

- (1) Project Owner (PO) firstly prepare Initial Environmental Impact Assessment (IEIA) reports based on assessment of existing environmental conditions and identification of environmental impact and its magnitude to be borne by project implementation. PO submits the report to MOE together with an Environmental Examination Application (EEA) and Pre-Feasibility Report.
- (2) MOE reviews reports whether it is acceptable to comply with the Sub-Decree or the project needs full-scale of EIA. The result of review is informed to PO within 30 days after submittal of the reports.
- (3) The PO revises and/or prepares report based on the instruction from MOE and submission again.
- (4) MOE examines the IEIA or EIA report and notify the PO comments, if any, within another 30 days after 2nd submittal. The PO then can receive the approval from MOE for project implementation after all the revision of the report is made.

Source: Sub-Decree on Environmental Impact Assessment Process

Procedure of Environmental Impact Assessment

In addition, format of EIA report is instructed by the Guideline for Conducting Environmental Impact Assessment Report (2000).

Agriculture projects necessary for IEIA or EIA is clearly defined in the Sub-Decree, which is tabulated as follows:

Agriculture Related Projects Requiring an IEIA or an EIA

Type and Activities of Projects		Size / Capacity
1. Agriculture		
(i)	Concession forest	≥ 10,000 ha
(ii)	Logging	≥ 500 ha
(iii)	Land covered by forest	≥ 500 ha
(iv)	Agricultural and agro-industrial land	≥ 10,000 ha
(v)	Flooded and coastal forests	All sizes
(vi)	Irrigation systems	≥ 5,000 ha
(vii)	Drainage systems	≥ 5,000 ha
(viii)	Fishing ports	All sizes
2. Projects Related to Agriculture		
(i)	Food processing and canned goods	≥ 500 ton/year
(ii)	All fruit drinking manufacturing	≥ 1,500 liters/day
(iii)	Fruit manufacturing	≥ 500 ton/year

Type and Activities of Projects		Size / Capacity
(iv)	Orange juice manufacturing	All sizes
(v)	Sugar refinery	≥ 3,000 ton/year
(vi)	Rice mills and cereal grains	≥ 3,000 ton/year
(vii)	Chemical fertilizer plants	≥ 10,000 ton/year
(viii)	Pesticide industry	All sizes
(xi)	Animals food processing	≥ 10,000 ton/year

Source: Annex of Sub-Decree on Environment Impact Assessment Process

In the irrigation sector, it is stated that an IEIA or EIA is required for the projects with more than 5,000 ha.

As decentralization process is being applied at Provincial level also within the administration of environmental management, EIA process is not left out. In the case of projects with the cost of less than US\$ 2 million, Provincial Environmental Department (DOE) is responsible for EIA approval while others with the cost of more than US\$ 2 million must be reviewed and approved by MOE Central.²

(5) Pollution Standard Related with Irrigation

In this section, pollution standard is explained based on Cambodian regulatory framework. In related with irrigation sector, management of “water quality” and “noise,” latter of which is particularly during construction phase of the project, are focused.

(i) Water Quality

Water quality management is stipulated in Sub-Decree on Water Pollution Control issued in 1999. It consists of effluent discharge permit, monitoring of the pollution sources, procedures and penalty. In the irrigation sector, water quality for river, lakes and reservoir are the high concerns; standard of which shown in the Sub-Decree is as tabulated below:

Water Quality Standard in Public Water bodies for Bio-Diversity Conservation			
No	Parameters	Unit	Standard Value
Rivers			
1	pH		6.5 - 8.5
2	BOD	Mg/l	1 - 10
3	Suspended Solids	Mg/l	25 - 100
4	Dissolved Oxygen	Mg/l	2.0 - 7.5
5	Coliform	MPN/100ml	< 5,000
Lakes and Reservoirs			
1	pH		6.5 - 8.5
2	COD	Mg/l	1 - 8
3	Suspended Solids	Mg/l	1 - 15
4	Dissolved Oxygen	Mg/l	2.0 - 7.5
5	Coliform	MPN/100ml	< 1,000
6	Total Nitrogen	Mg/l	0.1 - 0.6
7	Total Phosphorus	Mg/l	0.005 - 0.05

Source; Annex 4 of Sub-decree on Water Pollution Control

Although standard is prepared, monitoring station establishment is still in progress. There is

² Under decentralized mechanism, MOE also focus on devolving to DOE environmental monitoring through technical support and capacity development of DOE as well.

only one water quality monitoring station under MOWRAM, located in Battambang Province. No monitoring is carried out in the Pursat River Basin

(ii) Noise Pollution

Noise pollution standard, which is closely related with irrigation works particularly during construction, is defined in Sub-Decree on Air and Noise Pollution Control enacted in 1998. The maximum permitted level of noise at different locational conditions is as tabulated below:

Maximum Permitted Noise Level in Public and Residential Areas (dB(A))

No	Area	Period of time		
		From 6 am To 6 pm	From 6 pm To 10 pm	From 10 pm To 6 am
1	Quiet Areas, Hospitals, Libraries, Schools, Kindergartens	45	40	35
2	Residential Area, Hotels, Administration offices, Houses	60	50	45
3	Commercial and service area and mix	70	65	50
4	Small industrial factories, intermingling in residential areas	75	70	50

Source; Annex 6 of Sub decree on air and noise pollution

1.3 Screening of the Sub-Projects

IEIA is carried out for the Damnak Ampil Rehabilitation Sub-Project although its command area extends to 2,300 ha which is less than prescript area, 5,000 ha, in the Sub-Decree on EIA process. The sub-project only consists of rehabilitation of existing irrigation systems with no new land development. All the fields are currently cultivated with paddy and partially upland crops. Therefore, its adverse potential environmental impacts on human population or environmentally protected and/or important areas are judged less, which are site-specific and few are irreversible.

Under the Study, therefore, only IEIA is carried out as part of Pre-F/S to confirm potential positive and negative environmental impact to be expected from the Sub-Project, requirement for which is also stipulated in the guideline issued by Japan International Cooperation Agency (JICA). And environmental management plan is prepared so as to ensure sustainability of the sub-project from environmental point of view.

CHAPTER 2 PROCEDURE OF THE ENVIRONMENTAL STUDY

An Initial Environmental Impact Assessment has been carried out for the Sub-Project on the basis of the sub-decrees and guidelines as explained in Chapter 1. The survey was through both qualitative and quantitative manners by means of interview survey, field reconnaissance and preliminary measurement.

2.1 Stakeholder Consultation

Stakeholder consultation was carried out through two methodology: (i) Interview Survey and (ii) Workshop and/or Public Meeting as described as follows:



Interview Survey in Commune
(May 30th, 2008)

(1) Interview Survey

An interview survey was carried out to confirm socio-economic conditions, agriculture practice, and irrigation O&M and water management and to extract opinions of stakeholders as follows:

Contents of Questionnaire	
Part 1	Socio-Economy
Section I	General information about socio-economy
Section II	Living condition
Section III	Income and expenditure
Section IV	Savings and loan
Part 2	Agriculture
Section I	Livestock and fruits trees
Section II	Land holding
Section III	Cropped area & production (crop year 2005/2006)
Section IV	Farming practices (practices adopted by interviewee in the last year)
Section V	Production (crop year 2005/2006)
Section VI	Post-harvest, processing and marketing
Section VII	Agricultural support services
Section VIII	Farming constraints and improvement
Section IX	Livestock Constraints
Section X	Expectation
Section XI	Participation in agricultural support/project activities in the past
Part 3	Irrigation/Drainage & Water Management
Section I	Participatory awareness level for the project
Section II	Negative effect
Section III	Irrigation, water management & farmers water users community (FWUC)
Section IV	Flood damage
Part 4	Crop Budget
	Wet Season Rice Cultivation
	Dry Season Rice Cultivation

(2) Environmental Discussion in the Workshop

Environmental conditions and constraints are confirmed and discussed among stakeholders through questionnaire in the qualitative manner, which would be effective for qualitative assessment of environmental conditions in the sub-project area as well as enhancement of understanding toward environment among stakeholders. The issues discussed are listed as follows:

- **Natural Environment:** deforestation, water quality problem, water contamination, groundwater contamination, soil erosion, water logging, salinity problem, water-borne disease, soil contamination, and salinity problem
- **Irrigation Water Supply:** frequency of irrigation water
- **Social Environment:** conflict of water right with other system, conflict of water distribution within the sub-project, conflict of land allocation, illegal cropping, and flood damage
- **Others:** historical/cultural heritage, protected/conserved area, endangered species, precious ecology, environmental management activities, member of FWUC, and interested in FWUC

2.2 Field Reconnaissance

Field reconnaissance was conducted to confirm natural and ecological environment of the sub-project area. Current condition of O&M and water management of irrigation system was also surveyed so as to prepare improvement plan from the view point of social environment.

Quantitative water quality analysis was carried out for preliminary basis using water quality analysis equipment to supplement water quality data currently being collected by MOWRAM.

CHAPTER 3 SUB-PROJECT BRIEF

3.1 Background and Justification of the Sub-Project

The Lake Tonle Sap and its catchment area have been playing an important role for poverty alleviation as well as economic growth in Cambodia. The main economic activity in the region is agriculture by producing rice as a main crop. Most of the irrigation systems in this region was constructed between 1975 and 1979 during Pol Pot Regime. At present, they are significantly deteriorated, therefore, actual irrigation rate remains only 10 %. Revitalization of those irrigation systems is of critical importance in order to enhance country's food security.

On the basis of such background, the Royal Government of Cambodia (RGC) requested the Government of Japan (GOJ) to carry out technical assistance for the Basin-wide Basic Irrigation and Drainage Master Plan Study in the selected four river basins. In response to this request, the GOJ dispatched a preparatory study team in May 2005 to select river basins for the Study: Battambang, Mounng Russey, Pursat and Boribo. The GOJ in succession dispatched the Mission for the Scope of Work (S/W) in August 2006 to discuss and finally agree the S/W for the Study with the RGC.

The full Study has been being carried out since January 2007 until February 2009 as the schedule illustrated as follows:

Schedule of the Study

Activity	Phase 1												Phase 2														
	2007						2008						2009														
	FY2006			FY2007						FY2008						2009											
	1st Year			2nd Year						3rd Year																	
	J	F	M	A	M	J	J	A	S	O	N	D	J	F	M	A	M	J	J	A	S	O	N	D	J	F	M
Work in Cambodia	■			■						■						■											
Work in Japan	□										□												□				
Report	▲										▲	▲			▲								▲	▲			▲
	IC/R										P/R(1)	IT/R			P/R(2)								P/R(3)	DF/R			F/R

FY: Fiscal year in Japan

In the course of the Study, Damnak Ampil Rehabilitation Sub-Project was selected as one of the priority projects in the Pursat River Basin from the view point of comprehensive set of criteria: (i) resource factor, (ii) economic factor, (iii) social factor, (iv) environmental factor, (v) ease of implementation, and (vi) maturity factor. As evident, implementation of Damnak Ampil sub-project is expected to contribute to the enhancement of food security in Cambodia through technically appropriate, economically sound, sociologically suitable and environmentally friendly ways.

3.2 Type, Size and Location of the Sub-Project

The sub-project aims to revitalize irrigated agriculture primarily by: (i) the rehabilitation of irrigation facilities, (ii) FWUC establishment and strengthening and (iii) agricultural and other support.

Item	Description				
	1 Location	District	Commune	Village	UTM Reference
SamPovMeas		LorLokSar	DamNakAmPil	370829	1380406
2 River basin/ water source	Pursat river basin/ Pursat river				
3 Target group	1) Number of household = 2,000 (Wet season medium- paddy) 2) Staff of PDOWRAM and PDA				
4 Objective of the project or program	Enhancement of rice production through rehabilitation of existing irrigation system				
5 Type of project or program	1) Improvement of existing automatic gate on Pursat River 2) Rehabilitation of existing irrigation system/ Construction of canals				
6 Objective area	2,270 ha				
7 Necessity of project/program	<p>Damnak Ampil weir commenced the service in 2007. The main canal was rehabilitated for 7 km, and remaining main canal section of 13 km, and construction of the whole length of secondary and tertiary canals were left. Although upstream 7km of the main canal was constructed, secondary canal has not been constructed. In addition, automatic gate does not smoothly works as expected. Therefore, project outcome has not been necessarily materialized. The sub-project aims to rehabilitate automatic gate and to construct secondary canals under the command area so as to expedite the effectiveness of irrigation rehabilitation carried out by MOWRAM.</p> <p>In addition, the weir has a high potential to irrigate existing systems located in the downstream area. In order to ensure the potential, improvement of the weir would be necessary.</p>				

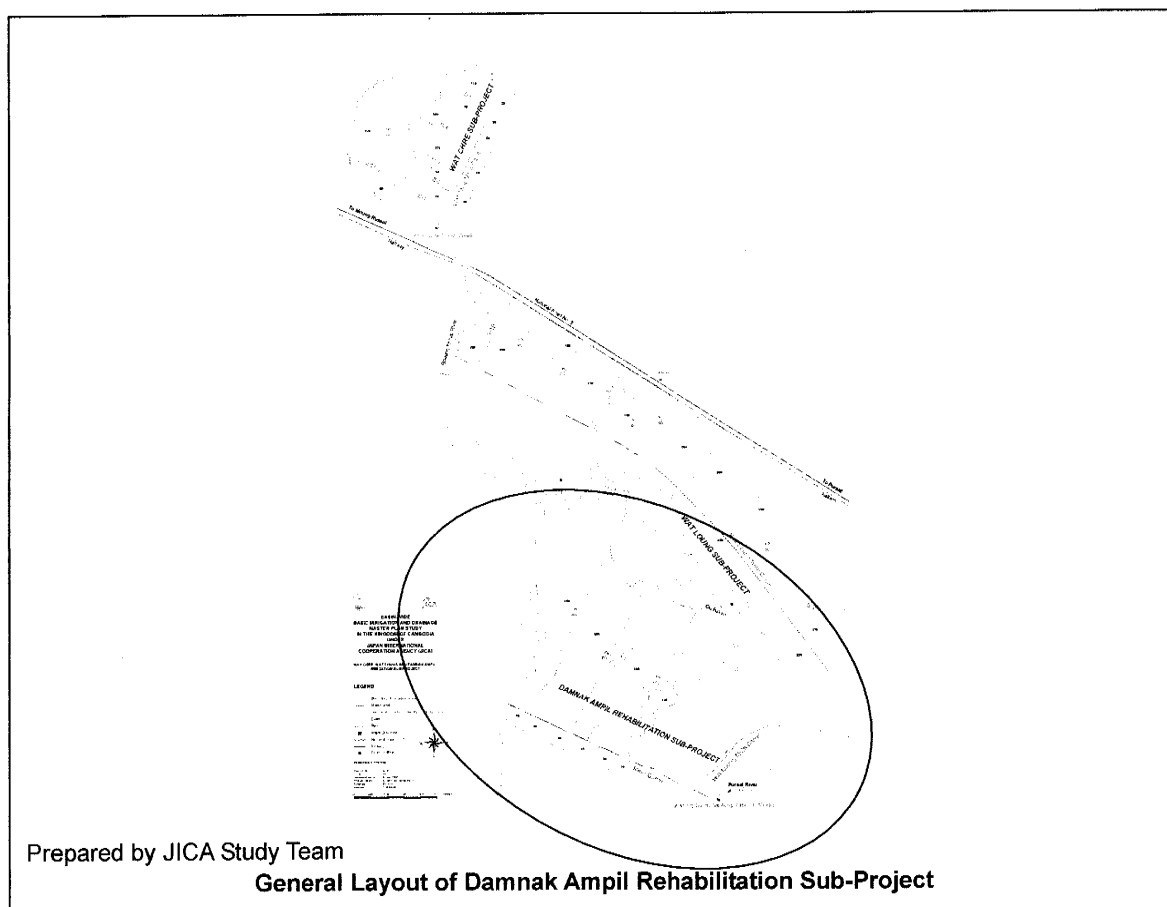

The Damnak Ampil Sub-Project is located in Sam Pov Meas District in Pursat Province. Command area spread to 2,270 ha in total. Water will be diverted from the Pursat River by rehabilitation of automatic gate originally constructed by MOWRAM in 2007. The main canal under the Damnak Ampil Sub-Project are expected to be extended in the future to the Svay Don Keo River so as to irrigate irrigation systems located in the downstream areas using Pursat River water.

3.3. Sub-Project Component

Component of the Sub-project is tabulated as follows:

No.	Description	Area and/or Number
1.	Sub-project area (ha)	2,270
	(Pump irrigation area included above)	(500)
2.	Annual irrigation area (Ha)	2,364
	- Early wet season paddy (Ha)	94
	- Medium wet season paddy (Ha)	2,270
	- Dry season paddy (Ha)	0
3.	Major water source	Pursat River
	- Name of headworks	Damnak Ampil (Existing)
	- Intake water level (EL. m)	17.00
	- Diversion water requirement at intake (m ³ /sec)	7.93
4.	Main canals (nos.)	1
	- Total length (km)	7.5
	- Capacity (m ³ /sec)	1.07 – 7.93
5.	Nos. of secondary canals	3
	- Total length (km)	17.6
	- Capacity (m ³ /sec)	0.98 – 1.07
6.	Number of Tertiary Blocks (No.)	50
	Total length of tertiary canals (km)	85
7.	Main drains	Ou Bakan / Boeung Khnar River
	- Total length (km)	-
	- Capacity (m ³ /sec)	Natural Stream
	- Drainage water requirement from paddy field (lit/sec/ha)	6.32
	- Drainage water requirement from other land (lit/sec/ha)	0.025–0.018
8.	Secondary drains (nos.)	4
	- Total length of secondary drains (km)	28.2
	- Capacity (m ³ /sec)	1.29 – 8.56
9.	Collector drains (nos.)	0
	- Total length of collector drain (New, km)	0
	- Capacity (m ³ /sec)	-

Prepared by JICA Study Team

Headworks and Major Facilities

Items	Description
- Improvement of Flood gate	Installation of new electric hoist: 7 sets Replacement of bushing: 7 sets
- Improvement of Scouring sluice gate	Replacement with electric hoist: 4 sets
- Construction of Fish Ladder	- width x height x length B:5.0m x H:4.6m x L:46m

Prepared by JICA Study Team

CHAPTER 4 PRESENT ENVIRONMENTAL CONDITIONS OF THE SUB-PROJECT AREA

4.1 Physical Environment

4.1.1 River Basin

The Pursat River Basin consist of the Pursat river Basin (4,596 km² at Khum Viel Station) and other small river basins. Main dimensions of the River Basin are summarized below showing that more than 90 % of the River Basin is higher than EL. 30. This River Basin has more mountainous area and narrow plain compared with other three River Basins under the M/P, resulting in surplus water resources in the Basin.

River Basin Dimensions

River Basin	Area (Km ²)	Lower area *1				> EL 30 *2		Highest Point*3 (m, amsl)
		EL 4-13		EL 14-30		(Km ²)	(%)	
		(Km ²)	(%)	(Km ²)	(%)			
Pursat	5,965	957	16	433	7	4,575	77	1,717

Data source: 1/ MOWRAM and “Tonle Sap Lowland Stabilization Project, Report on Water Availability, Sep., 2006”, financed by ADB; Original figure are rounded.

2/ The Study Team

3/ The Study Team from 1:100,000 scale topographic map

Prepared by JICA Study Team

4.1.2 Meteorology and Hydrology

(1) Meteorology

Climate of the Moug Russey River Basin is classified as tropical monsoon or savanna zone. Since there is no meteorological station in the Basin, meteorological values in the basin are estimated using those of Battambang and Pursat stations as tabulated as follows:

Average Monthly Meteorological Values at Pursat River Basin

Monthly	Jan	Feb	Mar	Apr	May	Jun	Jul	Aug	Sep	Oct	Nov	Dec	Annual
Temperature													
Mean (°C)	26.3	28.1	29.5	30.4	30.2	29.9	29.3	29.1	28.4	27.8	26.8	25.9	28.5
Mean max. (°C)	31.7	33.9	35.1	35.6	35.3	34.9	34.1	33.7	32.6	31.6	30.9	30.4	35.6
Mean min. (°C)	20.8	22.2	24.0	25.1	25.2	24.9	24.4	24.5	24.2	24.0	22.8	21.4	20.8
Relative humidity (%)	66	63	65	66	67	68	68	71	74	76	74	71	69
Wind velocity (m/s)	0.80	0.78	0.68	0.60	0.48	0.37	0.40	0.37	0.32	0.48	0.50	0.58	0.53
Sunshine hours (hr/day)	-	-	-	-	-	-	-	-	-	-	-	-	-
Evaporation (mm/day)	3.7	4.5	4.4	4.5	4.2	4.1	3.3	3.5	2.8	3.2	3.1	3.0	3.7
(mm)	115	126	138	135	130	121	102	107	83	98	93	92	1340

(2) Rainfall

Rainfall in the basin extends from 1,200 mm in the northern plain to 1,600 mm in the southern mountains. Annual rainfall at the Damnak Ampil Sub-project is 1,300 mm.

(3) Mean monthly flow

The monthly specific discharges are estimated for the plain or the sub-basins of the Pursat River Basin. The results are shown as follows:

Mean Monthly Discharge of Pursat River Basin

	80 % Dependability											(lit/s/km ²)
	Jan	Feb	Mar	Apr	May	Jun	Jul	Aug	Sep	Oct	Nov	
Pursat River Basin												
(e1) PR-H: Pursat Hill	1.8	1.2	1.0	1.3	1.6	3.8	8.1	17.5	17.7	37.0	11.8	3.5
(e2) Pursat River Basin in Plain	0.0	0.0	0.0	0.0	1.4	3.9	5.8	7.8	16.6	26.0	9.1	0.0
(f) PR-P: Pursat Plain	1.8	1.0	0.9	0.8	3.5	4.2	6.3	7.9	17.8	27.5	20.5	4.6

(4) Flood

Probable flood discharge is calculated as shown below. Since the available data is limited, return period of 5-year, 10 year and 20 year is calculated only.

Probable Flood Discharge

Unit: m³/s

Station	Return Period or Recurrence Interval					Data
	5	10	20	50	100	(Year)
Pursat River Basin						
Khum Viel	520	550	580			9
Bac Trakoun	1,000	1,200	1,390			6

Note: Blank – not calculated due to short data period

Prepared by JICA Study Team

Flood water often overtops the river banks after coming out from the mountainous area to the plain, resulting in reduced flood discharge along the downstream reach. Field survey as well as the river channel meandering scale suggests happening of such phenomenon.

4.1.3 Soils

The soils distributed in the basin are classified at soil sub-unit level following the FAO/UNESCO classification system into 9 soil types (sub-units) as shown in Figure 4.1.1 and in the following table.

Soil Distribution in the Pursat River Basin

Soil Sub-unit	Distribution	
	(ha)	(%)
Gleyic Acrisol/Plinthic Acrisol	168,620	28
Dystric Fluvisol (FLd)	14,940	3
Dystric Gleysol (GLd)	41,940	7
Dystric Leptosol (LPd)	67,920	11
Dystric Leptosol/Dystric Cambisol	303,530	51
Total	596,500	100

Prepared by JICA Study Team

The river basin is characterized by the distribution of medium textured soils in the middle to lower basin and the distribution of fine textured soils in the seasonally inundated lowland areas close to the Tonle Sap Lake. The dominant soil distributed in the paddy fields of the basin is the association of Gleyic Acrisol and Plinthic Acrisol.

4.1.4 Noise and Air Quality

There is no data related with noise and air quality in and around sub-project areas. It is conceivable that no serious noise pollution source exist in this area. In addition, as for air quality, only power generators of the private company and traffic particularly national road No.

5 and access to the command area, distance of which is 10 km from the national road to the command area, would give negative impact to some extent. Those are, however, not serious at present.

4.1.5 Water Quality

Water quality was preliminary assessed through field survey in the wet season, June 12th, 2008. The indicators analyzed are: (i) pH, (ii) Electric Conductivity (EC) and (iii) Total Dissolved Solid (TDS). The results are tabulated as follows:

Result of Water Quality Analysis

Name	Sampling Point	Date	pH	EC (μS/cm)	TDS (mg/l)	Remarks (Coordinate of sampling points, UTM)
Dammak Ampil Rehabilitation	BP of main canal	12-Jun-08	7.6	29.5	14.6	N=1380735, E=0370279
	Mid-stream of secondary canal	12-Jun-08	6.1	51.5	25.9	N=1382289, E=0367706
	EP of existing main canal	12-Jun-08	6.2	36.4	18.1	N=1383801, E=0363705
Water Quality Standard	River		6.5-8.5	None (<70 μS/cm) Slight to Moderate (70-300 μS/cm) Severe (>300μS/cm)	<450	Standard for pH is given from Sub-Decree showing water quality for public water areas while that of EC and TDS is given from FAO specifically for irrigation purpose.

Note: Water quality standard is given from relevant document as follows:

pH: Ministry of Environment (1999), Sub-decree on Water Pollution Control

EC and TDS: FAO (1994), Water Quality for Agriculture, Irrigation and Drainage Paper 29

Prepared by JICA Study Team based on field sampling and analysis

According to the relevant guidelines: (i) MOE, Sub-Decree on Water Pollution Control and (ii) FAO, two points, mid-stream of secondary canal and EP of existing main canal, shows lower level of pH than that in standard. These would be possibly given from water stagnation and inflow of effluent at sample sites.



Water Stagnation in the Command Area due to no Drainage Developed (June 12th, 2008)

4.2 Biological Environment

4.2.1 Vegetation and Land Use

The present land use of the sub-project area is paddy field under different irrigation statuses. Accordingly, the land use of the area has been classified based on current irrigation statuses into 2 sub-categories of : i) paddy fields with normal irrigation, ii) supplemental irrigation paddy field and iii) rainfed paddy field (including field

under rainfed condition). Rainfed paddy field particularly in the wet season is the major land use in the Damnak Ampil command area.

4.2.2 Wild Life

Wildlife are rarely observed in and around the sub-project areas since the areas have been already cleared for agriculture particularly paddy cultivation. All the protected or conserved areas are located in the outside of sub-project areas. There are no detailed information, however, wild animals observed in and around the area include: (i) wild pig, (ii) rabbits, (iii) some species of reptiles such as snakes and turtles in accordance with the field interview.

4.2.3 Protected Areas

Figure 4.2.1 shows protected areas of the Pursat River Basin where the Damnak Ampil sub-project is located. There are four protected areas: (i) Aural Wildlife Sanctuary, (ii) Phnom Samkos Wildlife Sanctuary, (iii) Tonle Sap Multiple Use Area and (iv) Cardamom Protected Forest situated in the Basin, characteristics of which are tabulated as follows:

Protected Area in Pursat River Basin

Protected Area	Province	Total Area (ha) (Area in Basin, %)	Relevance with Basin Irrigation	Some Unique Characteristics
Aural Wildlife Sanctuary	Pursat Province	253,750 (57,900, 22.8 %)	The upstream of irrigation systems in southern basin area	Highest mountain (1743m) in Cambodia with a wide diversity of vegetation ranging from dry Dipterocarpus / Podocarpus forest to medium altitude evergreen forest.
Phnom Samkos Wildlife Sanctuary	Crossing Battambang and Pursat Province	333,750 (98,900, 29.6 %)	The upstream of irrigation systems	High altitude area with a wide diversity of forest types. Supports a range of threatened birds in the area
Tonle Sap Multiple Use Area	Pursat Province	316,250 (26,800, 8.5 %)	The downstream of irrigation systems in northern part of basin	Long-standing ichthyological reserve. Great biological, hydrological and cultural/economic importance.
Cardamom Protected Forest	Pursat Province	401,300 (102,600, 25.6 %)	The upstream of systems in south-east basin area	Known to contain almost all the country's known mammals, birds, reptiles and amphibians. This is partly due to the very high diversity of habitats, some of which occur nowhere else in Cambodia such as large expanses of fire-regulated ferns, upper montane forest, high elevation marshes and blackwater rivers.

Prepared by JICA Study Team based on Ministry of Environment (2004), State of Environment Report and Fauna and Flora International

Aural, Phnom Samkos and Cardamom are located in the upstream of most of irrigation systems in the river basin, therefore, there would be no serious impact through irrigation development in the basin. On the other hand, Tonle Sap Multiple Use Area is in the downstream of the Sub-Project. Increase of usage in fertilizer and pesticide generally seen

through promoting irrigation development would possibly more or less affect water quality, if inappropriate and excessive application is carried out.

There are no protected areas or conserved area within the command area of Damnak Ampil Rehabilitation Sub-Project.

Instead, commune members have been planting trees for the mitigation of soil erosion assisted by the Provincial Department of Environment (DOE), Pursat, along the right side of the main canal. Such awareness among communes would be appreciable for the future community-based environmental management under the sub-project.



Community Forest Managed by the Community (February 2nd, 2008)

4.3 Social Environment

4.3.1 Population, Community and Ethnicity

The Sub-Project covers Sampov Meas and Bakan Districts in Pursat Province primarily covering three communes: (i) Lolok Sar, (ii) Trapeang Chong, (iii) Ta Loas and (iv) Snam Preah. Total household under the command area approximately is 2,000 nos.

The community, in common with the religion in general, is Khmer and Buddhist, with no presence of ethnic minorities or immigrants of other nationalities under the sub-project area.

4.3.2 Education

Educational level of villagers are generally low as tabulate below, as most of farmers in the sub-project area have had only “no formal education” and/or “drop-out at primary school.”

Education Career of Farmers

N=30

Career Number & %	No Formal Education	Drop-out at primary school	Graduate from primary school	Drop-put at junior high school	Graduate from junior high school	Drop-out at high school	Graduate from high school	More than high school	Others
Number	9	10	2	6	2	1	0	0	0
Percentage	30.0%	33.3%	6.7%	20.0%	6.7%	3.3%	-	-	-

Prepared by JICA Study Team based on Interview Survey carried out during the Study

4.3.3 Health and Hazard

According to the interview survey to farmers, dengue, malaria, diarrhea etc. were pointed out as the commonly contracted diseases in the sub-project area. Insufficient knowledge among communities about the diseases is one of the main reasons for expansion of those. On the other hand, lack of water source particularly in dry season would be the reason for diarrhea disease. Situation of access to health and medical services in the sub-project area is shown as follows:

When you/your family get/gets sick, where do you go?

N=30

	Hospital	Clinic	Health Centre	Others
Number	2	3	22	3
Percentage	6.7%	10.0%	73.3%	10.0%

Prepared by JICA Study Team based on Interview Survey carried out during the Study

Health Centre is the major medical facilities accessible to communities. Additionally, results of the interview survey show that no interviewees have some kind of social security service/insurance.

4.3.4 Historical and Religious Sites

There are no archeological and/or historical significance in and/or around the Damnak Ampil Sub-Project area.

4.3.5 Economic Condition

(1) Main Economic Activity

As shown in the following table, all the interviewee under the Damnak Ampil Sub-Project replied that the main economic activity is agriculture. Other activities observed in the community during field survey are: (i) collection of livestock raising, (ii) temporary workers for construction, (iii) kiosk selling vegetables and/or processed products for value-addition.



Kiosk in the Lolok Sar Commune as an Income Source of Female (February 2nd, 2008)

Main Activity of the Household

N=30

	Farmer	On-farm Labor	Non-Farm Labor	Salary Worker	Private Business	Others
Number	30	0	0	0	0	0
Percentage	100.0%	-	-	-	-	-

Prepared by JICA Study Team based on Interview Survey carried out during the Study

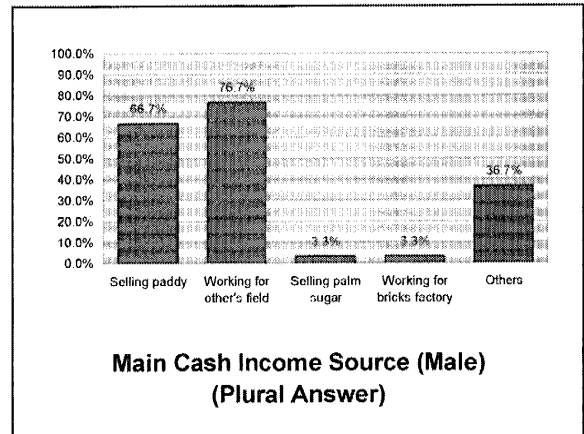
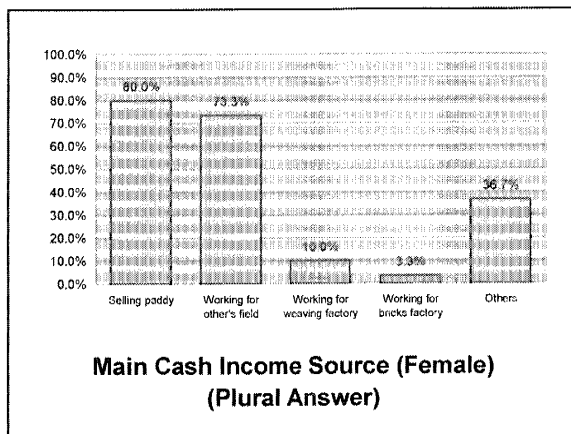

Working for their own farm and for assisting others occupies highest percentage for main cash income in both female and male under the sub-project.

(2) Present Agriculture

Rice production is the most important agricultural activities in the sub-project area and nearly 100 % of farm households in the project communes had engaged in wet season rice cultivation in 2003. Rice production in the area is characterized by low and unstable productivity under rainfed conditions. Rice cultivation in dry season by pumping irrigation is practiced in a limited extent. No other crops are cultivated in the paddy fields in the area.

Prolonged rice cultivation season continuing from July/August to November/December with the cultivation of rice varieties of different growth durations of medium to late and traditional farming practices are other characteristics of the rice production in the area. Major varieties grown are as follows;

Major Varieties Grown in the Sub-project Area

Season	Growth Duration	Variety
Wet Season	Medium	Phka. Rumdoul, Phka Khney, Phka Mulis, Somali
	Late	Neang Pong, CAR 4, CAR 7, CAR 9, Kang Threung
Dry Season	Early	IR, Sen Pidao

Prepared by JICA Study Team

The prevailing cropping calendar in the area estimated based on the interview survey results is illustrated as shown in the following figure.

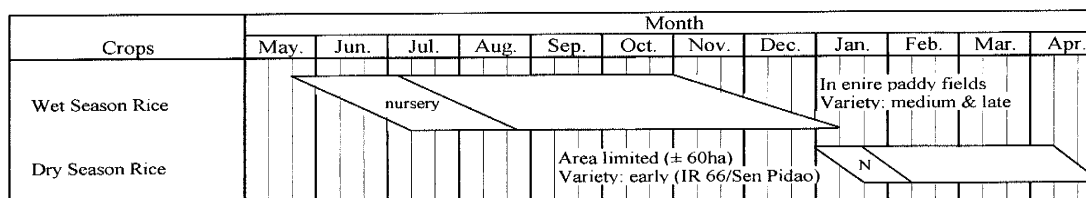

Prepared by JICA Study Team

Prevailing Cropping Calendar in Paddy Fields: Damnak Ampil Sub-project Area

The current cropped areas of rice and other crops in the sub-project area have been estimated as follows.

Estimated Cropped Area & Cropping Intensity in the Sub-project Area

Cropping Season	Cropped Area (ha)		Cropping Intensity (%)
	Rice	Other Crops	
Wet Season	Intensity 100%	-	100
Dry Season	60	-	-
Annual	-	-	-

Note the extent of the sub-project area is being finalized.

Source: JICA Study Team

According to the Commune Survey on Crops & Livestock, 2003 presented by the Ministry of Agriculture, Forestry and Fisheries (MAFF), average cropped area of wet season rice per household is 1.1 ha.

(3) Local Living Standard

Local living standard were rapidly assessed by way of poverty ranking and focal group discussion. Poverty level was classified into four: (i) Destitute (poorest), (ii) Poor, (iii) Fair, and (iv) Rich. Poverty is multi-dimensional, complex, and each local community embraces

different concepts of risks. Classification is, therefore, made from the view point of (i) income level, (ii) asset owned including land, (iii) education level, (iv) satisfaction level of basic human needs, and (v) financial transaction with financial institutions, and levels of each item are determined by the workshop attendants. The result is shown in Table 4.3.1 and summarized as follows showing that “Poor” and “Destitute” occupies 55 % of community members:

Income, its Source and Land Owned by Farmers at Damnak Ampil Rehabilitation Sub-Project

Classification	Number of Family	Percentage	1. Income		2. Asset
			Average Income per day (Riels)	Source of Income (main economic activity)	Land (ha)
Destitute	30 F	1.5 %	0-1,000	Labors	0.5
Poor	1,070 F	53.5%	1,000-3,000	Labor, go to Thai border, garment factory worker	0.5-1
Fair	850 F	42.5%	3,000-5,000	Trader, husbandry, Working on rice field, land owner	1-2
Rich	50 F	2.5%	5,000-8,000	Money lender, Trader, land owner	>2
Total	2,000 F	100%			

Prepared by JICA Study Team based on Workshop carried out during the Study

In relation to local economic conditions, land holding status was surveyed, results of which are as follows:

Status of Land Holding

N=30

	Owner Cultivator	Owner cum Sharecropper	Sharecropper	Owner cum Tenant	Tenant	Not Operating Any Farm
Number	29	0	0	1	0	0
Percentage	96.7%	-	-	3.3%	-	-

Prepared by JICA Study Team based on Interview Survey carried out during the Study

Owner cultivator occupies high percentage that 96.7 % of total farmers are categorized in “Owner Cultivator.”

(4) Community-based Organizations

Community-based organizations are one of the important engines for supporting economic activities. The following table shows community-based organizations in which farmers currently are involved.

Member of Community-based Organization

N=30

	FWUC and/or Water Users' Group	Credit (Gov.)	Credit (NGOs)	Agriculture	Religion	Drinking Water	Market	Youth	Veteran	Women	No
Organization	1	0	1	0	4	0	0	2	0	4	20
Percentage	3.3%	-	3.3%	-	13.3%	-	-	6.7%	-	13.3%	66.7%

Prepared by JICA Study Team based on Workshop carried out during the Study

Religious organization is major under the Damnak Ampil Sub-Project. Although, FWUC has been already established and under processing for registration at PDOWRAM Pursat, awareness among farmers are not necessarily high at present.

4.3.6 Present Water Use by Affected Communities

(1) Drinking and Domestic Water Use

Current sources of drinking and domestic water under the communities of the sub-project based on interview survey are tabulated as follows:

Drinking Water Source (Dry Season)

N=30

	Piped	Tube Pipe Well	Dug Well	Reservoir / Pond	Spring / River	Bought	Rain	Others
Number	0	4	15	9	1	0	0	1
Percentage	-	13.2%	50.0%	30.0%	3.3%	-	-	3.3%

Prepared by JICA Study Team based on Interview Survey carried out during the Study

Drinking Water Source (Wet Season)

N=30

	Piped	Tube Pipe Well	Dug Well	Reservoir / Pond	Spring / River	Bought	Rain	Others
Number	0	1	7	7	1	0	12	2
Percentage	-	3.3%	23.3%	23.3%	3.3%	-	40.0%	6.8%

Prepared by JICA Study Team based on Interview Survey carried out during the Study

Domestic Water Source (Dry Season)

N=30

	Piped	Tube Pipe Well	Dug Well	Reservoir / Pond	Spring / River	Bought	Rain	Others
Number	0	4	15	9	1	0	0	1
Percentage	-	13.3%	50.0%	30.0%	3.3%	-	-	3.4%

Prepared by JICA Study Team based on Interview Survey carried out during the Study

Domestic Water Source (Wet Season)

N=30

	Piped	Tube Pipe Well	Dug Well	Reservoir / Pond	Spring / River	Bought	Rain	Others
Number	0	1	7	9	1	0	10	2
Percentage	-	3.3%	23.3%	30.0%	3.3%	-	33.3%	6.8%

Prepared by JICA Study Team based on Interview Survey carried out during the Study

Main water source for drinking and domestic water among communities is reservoir and/or pond followed by dug well particularly in dry season. People largely depend on rain water in the wet season as generally seen in rural areas.

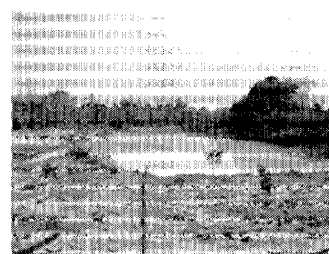

Community-managed Pond as one of the Domestic Water Source (February 2nd, 2008)

(2) Irrigation Water Use

Damnak Ampil gate and main canal with the length of 7 km was constructed by MOWRAM in 2007. However, development of secondary and tertiary canals and drains still lag behind. Irrigation water is, therefore, not stably distributed within the

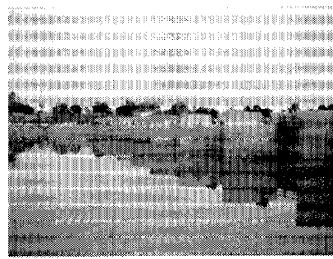

Damnak Ampil Gate on Pursat River Constructed by MOWRAM in 2006 (February 2nd, 2008)

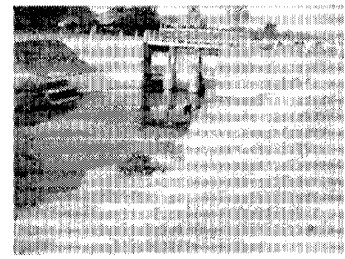

Diversion Structure on Main Canal (February 2nd, 2008)

command area. Instead, farmers are largely dependent on rainfall and flood water especially in the wet season. Interview survey asking for present source of irrigation water and method of irrigation is illustrated as follows showing that 70 % of the farmers primarily rely only on rainfall at present. Others mention some water is provided through irrigation facilities. Therefore, rehabilitation of irrigation facilities particularly promotion of secondary and tertiary canals development will surely contribute to the

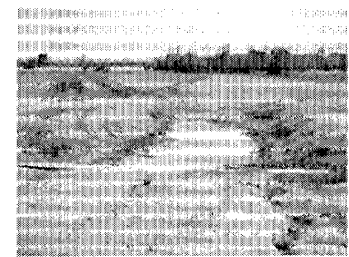

Outlet of Diversion Structure with no Secondary Canal Constructed (February 2nd, 2008)

constancy of irrigation water supply in the Sub-Project command area.

Under such conditions, farmers' groups are not functioning as a group for O&M of irrigation facilities and water management. As mentioned in 4.3.5, FWUC has been established, awareness and/recognition among farmers are quite low. In parallel with

facilities rehabilitation, therefore, FWUC strengthening would be of critical importance for sustainable irrigation development and management.

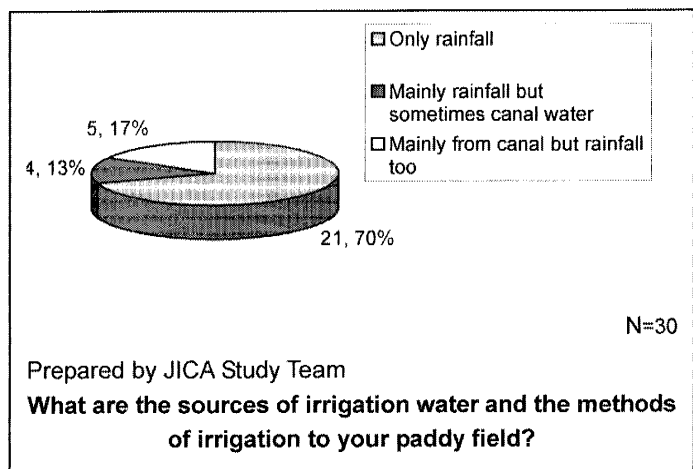

(2) Flood Condition

Although it would be difficult to control and regulate, flood water is also an important source of water for agriculture. Necessity of flood management is huge in any irrigation development. In accordance with the interview survey, current flood condition is illustrated on the right showing that 27 % of the people are suffering from flooding at once a year, water of which comes from the Pursat River. The asset damaged by flood is mostly reported to be paddy field.

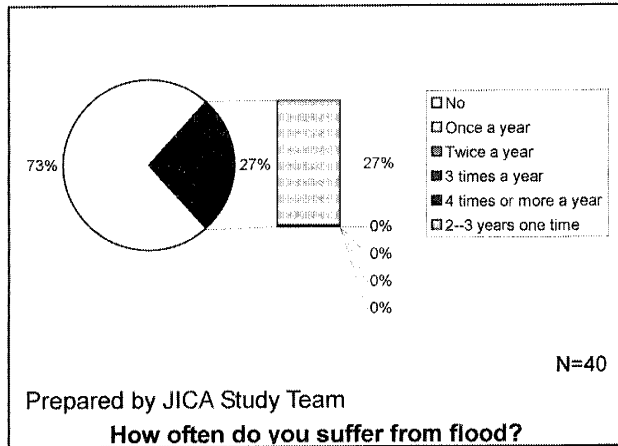

CHAPTER 5 STAKEHOLDERS OF THE PROJECT

5.1 Local Authorities and Institutions Involved

Institutional linkage and production-marketing flow process map was prepared through public meeting in order to identify the “influence/benefit” as well as the “closeness” of institutions in surrounding areas of the sub-project toward two communes: (i) Lolok Sar and (ii) Snam Preah, under the Sub-Project as listed and shown in Figure 5.1.1 to Figure 5.1.4.

Two communes generally pointed out larger influence from PDOWRAM, PDA and Provincial Department of Rural Development (PDRD). In addition, relation with MOE and DOE is also an important. Influence of credit organizations are not necessarily high, which depend upon the availability of collateral of farmers. Among others, ACLEDA and Prasac are the two main credit institutions for farmers as generally observed in rural areas. NGOs’ and/or donors’ activities adhere to each commune rather than Sub-Project unit such as: (i) Racha, (ii) Abdo, (iii) SEILA Program etc. During the field survey, the Study Team visited PDOWRAM, PDOE and PDA to receive useful information for the Sub-Project. Relations with such institutions needs to be fully considered for capacity development plan of environmental management.



Institutional Linkage Explained
by the Participants
(January 31st, 2008)

5.2 Opinion of the Public Toward the Project

Socio-economic survey was carried out for selected farmers at Damnak Ampil sub-project.

Participants of Workshop and Public Consultation

No.	Organization	Participants
1.	National Counterparts and Steering Committee Member	Representative from MOWRAM (Department of Planning)
2.	Provincial Counterparts and Personnel Concerned	Chief of Meteorology Section, PDOWRAM Pursat
3.	Commune Councils	Chiefs and the members of the councils (7 members: Rolok Sar, Snam Preah and Khnar Toteung)
4.	JICA Study Team	Member of the Team
5.	Villagers	Villagers relevant to Damnak Ampil Rehabilitation Sub-Project (12 members: Damnak Ampil, Daob Bath, Khmar, Aren, Cheung Phleung, Thaak Tachab, Koh Krasaing, Krapeu Ro, Koh Wat, Koh Svay, Toul Ankraong and Kamprak Kon)

Prepared by JICA Study Team

As shown below, reasons for limited productivity of crops according to the perception by farmers are primarily related with irrigation and drainage facilities followed by the improvement of farming techniques. Necessity on the rehabilitation of irrigation and drainage facilities are justified from farmers’ view point.

Reasons for Limited Productivity of Crops Perceived by Farmers

N=30

Career Number & %	Relevant to Irrigation and Drainage Facilities				Agriculture				Others
	Drought in Wet Season	Water Shortage in Dry Season	Poor Drainage	Flooding/ Inundatio n	Poor Seed Quality	Poor Soil	Limited Application of Fertilizer	Inadequate Farming Technology	
Number	17	4	2	2	1	2	1	1	0
Percentage	56.7%	13.3%	6.7%	6.7	3.3%	6.7%	3.3%	3.3	-

Prepared by JICA Study Team based on Interview Survey carried out during the Study

Through the discussion, sub-project component consisting of: (i) rehabilitation of irrigation and drainage facilities, (ii) FWUC establishment and strengthening and (iii) agricultural extension activities have been agreed by all the participants.

Level of awareness for participation in irrigation O&M and water management was assessed through questionnaire survey as shown on the right, question contents of which are largely categorized into three: (i) participation in construction of tertiary facilities, (ii) participation in FWUC's activities and (iii) participation in O&M of irrigation system.

A question was raised by the participant whether the sub-project under the Pre-F/S include extension area as proposed in the M/P. The Study Team replied that the necessity of revitalization of existing area needs to be firstly put priority, then the construction of extension area are in the next step which would be in the second phase of the Road Map 2020. The participant agreed to the explanation.



Presentation of Opinion toward the Sub-Project Component at Damnak Ampil (January 31st, 2008)

The result shows that the awareness on participation in construction and FWUC's activities are high among Damnak Ampil community. The construction works of Damnak Ampil gate and the main canal has been carried out in 2006, therefore, the awareness and expectation of the development of on-farm level facilities would be comparatively matured.

MOWRAM is currently promoting Participatory Irrigation Management and Development (PIMD) through transferring responsibility of O&M at tertiary level facilities to farmers. In this connection, farmers' intention toward PIMD is important for sustainable irrigation management. Table 5.2.1 shows the discussion result regarding PIMD with the questions of:

- (i) Who will be a prospective leader of FWUC?
- (ii) Who can be a member of FWUC?
- (iii) If irrigation system covers several communes, how will you organize FWUC?
- (iv) What kind of activities do you think required for FWUC in your project?

To improve efficiency in water resource utilization through the sub-project implementation, such opinions need to be considered for the assistance in the strengthening of FWUC at the

Damnak Ampil Sub-Project.

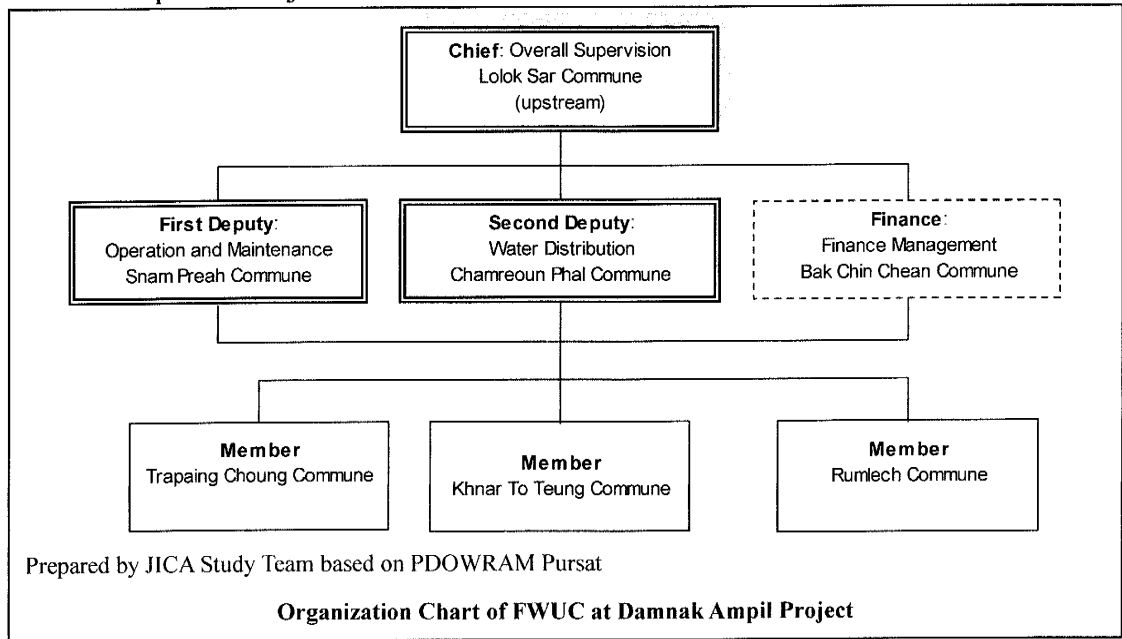

5.3 Present Environmental Issue

As part of the stakeholder consultation, current environmental issues were discussed and confirmed during the workshop from natural, social and other environment-related view points. As a result, it is confirmed that there are currently no serious environmental problems in and around the command area.

Social environmental issues were rather considered in the meeting. At present, no secondary and tertiary level facilities. Instead, the areas for prospective canal alignment are partly utilized for cultivation. Land acquisition Although farmers have really understood that such activities are drawn up before the commencement of the construction works according to the discussion in the workshop, proper steps and mitigation measures are required for consensus building among relevant institutions and farmers. Consensus building for land acquisition is also important to promote development of the tertiary level facilities.

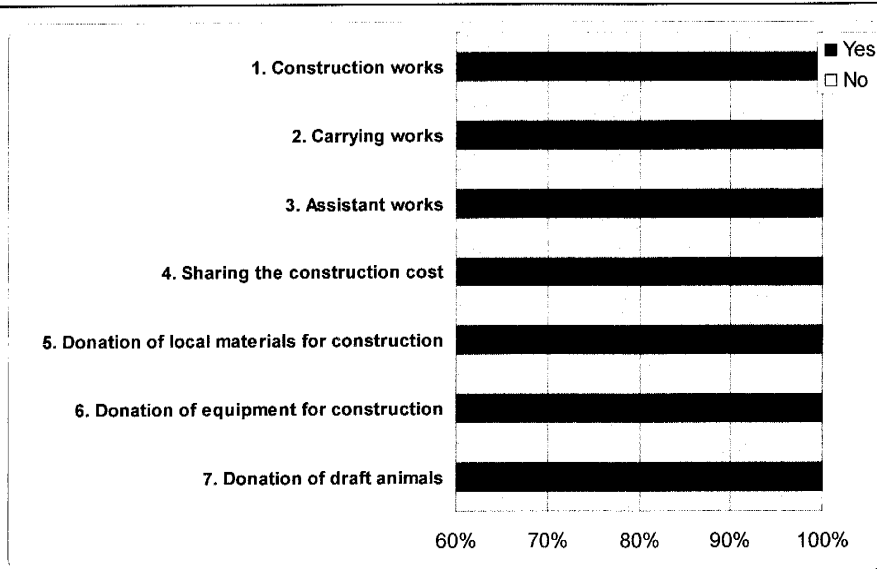

Participation in Construction of Tertiary Facilities

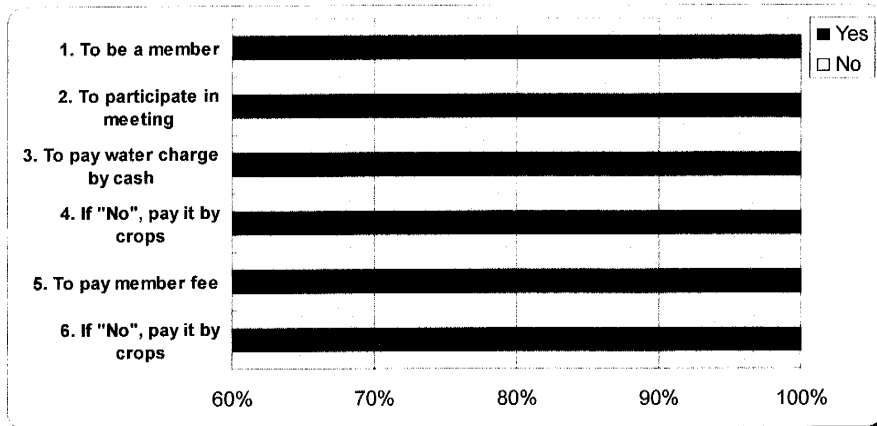

Participation in FWUC's Activities

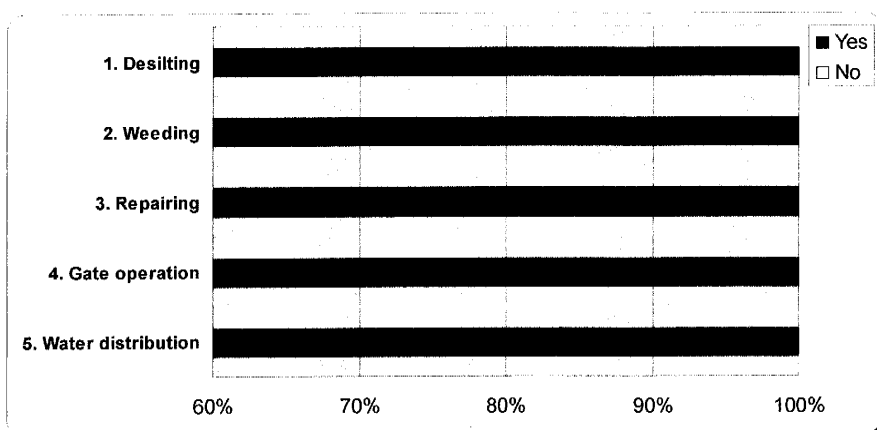

Participation in O&M of Irrigation System

Prepared by JICA Study Team based on Field Interview

Level of Awareness for Participation in Irrigation O&M and Water Management

CHAPTER 6 INITIAL ENVIRONMENTAL IMPACT ASSESSMENT

6.1 General

(1) Screening of the Sub-Project Component

Sub-project components primarily consist of: (i) rehabilitation and improvement of irrigation and drainage facilities, (ii) FWUC establishment and strengthening and (iii) agriculture support. Main subjects of FWUC establishment and strengthening and agriculture support are: (i) awareness program, (ii) module development, (iii) training and (iv) small-scale pilot exercise in agriculture and irrigation rehabilitation, therefore, adverse potential impact toward environment in and around the sub-project area is completely none or negligible or small. Thus activities (ii) and (iii) are screened out from IEIA. IEIA in this report concentrates on potential impact from the rehabilitation and the improvement of irrigation and drainage facilities.

(2) Scoping

An IEIA is carried out using matrix focusing on the aspect of: (i) social environment, (ii) natural environment and (iii) pollution as listed as follows on the basis of proposed component:

Social Environment

1. Involuntary resettlement
2. Local economy (employment and income generation)
3. Land use and resource mobilization
4. Social capital and traditional institution
5. Social infrastructure and services
6. The poor, indigenous and minority group
7. Unequal distribution of damage and benefit
8. Cultural heritage
9. Local conflict over interest
10. Water use
11. Sanitation
12. Risk against infectious diseases

Natural Environment

13. Topography and geographical features
14. Soil erosion
15. Groundwater
16. Hydrology
17. Coastal area such as mangrove, coral reef and tidal area
18. Flora, fauna and biodiversity
19. Meteorology
20. Landscape
21. Global warming

Pollution

22. Air pollution

23. Water pollution
24. Soil Contamination
25. Waste
26. Noise and vibration
27. Ground subsidence
28. Offensive odor
29. Sedimentation
30. Accidents

The result of IEIA is summarized in Table 6.1.1 for: (i) stage-wise impact, (ii) reason, (iii) mitigation measures and (iv) method and timing for monitoring. For the facilitation of understanding, mitigation measures, as detailed in Chapter 7, are also summarized in this matrix so that negative impact and mitigation measures are easily compared as the essence of IEIA.

6.2 Potential Negative Environmental Impact

Prospective negative environmental impacts identified are listed as follows:

Social Environment

- (i) Involuntary resettlement;
- (ii) Unequal distribution of damage and benefit;
- (iii) Local conflict over interest;
- (iv) Water use;
- (v) Sanitation;
- (vi) Risk against infectious diseases;

Natural Environment

- (i) Coastal area such as mangrove, coral reef and tidal area;
- (ii) Flora, fauna and biodiversity;

Pollution

- (i) Air pollution;
- (ii) Water pollution;
- (iii) Soil contamination;
- (iv) Waste;
- (v) Noise and vibration; and
- (vi) Accidents.

Brief description of each negative impact is shown in the following table.

Potential Negative Environmental Impact

Item		Stage		
		Preparation	Construction	O&M
Social Environment	Involuntary Resettlement	Land acquisition by the expansion and/or new construction of canals and drains (secondary and tertiary canals)	-	-
	Unequal Distribution of Damage and Benefit	Not all the communes under FWUC covered by the proposed command area	-	-
	Local Conflict Over Interest	-	Conflict among construction labors and farmers	Conflict over unequal water use
	Water Use	-	Reduction of drinking, domestic and irrigation water by river diversion	-
	Sanitation	-	Due to inflow of labors from outside	-
	Risk against Infectious Diseases	-	Due to inflow of labors from outside	-
Natural Environment	Coastal area such as Mangrove, Coral Reef and Tidal Area	-	-	Increase in chemicals and fertilizers application
	Flora, Fauna and Biodiversity	-	Disturbance of fish sprawling by construction works	Disturbance of fish sprawling by construction works
Pollution	Air Pollution	-	Emission gas from construction works	-
	Water Pollution	-	Waste water increase from construction works	Acceleration of nutrient load and/or chemical contamination in drainage water due to increase in chemicals and fertilizers application
	Soil Contamination	-	-	Misuse and/or excessive usage of chemicals and fertilizers
	Waste	-	Improper disposal of waste from construction works	-
	Noise and vibration	-	Due to construction machinery	-
	Accidents	-	Due to construction machinery	-

Prepared by JICA Study Team

CHAPTER 7 ENVIRONMENTAL MANAGEMENT PLAN

7.1 Environmental Impact Mitigation Measures

Environmental impact from the sub-project is identified from the view point of: (i) social environment, (ii) natural environment and (iii) pollution in the previous chapter. Causal relations of negative environmental impact and possible mitigation measures are shown as follows:

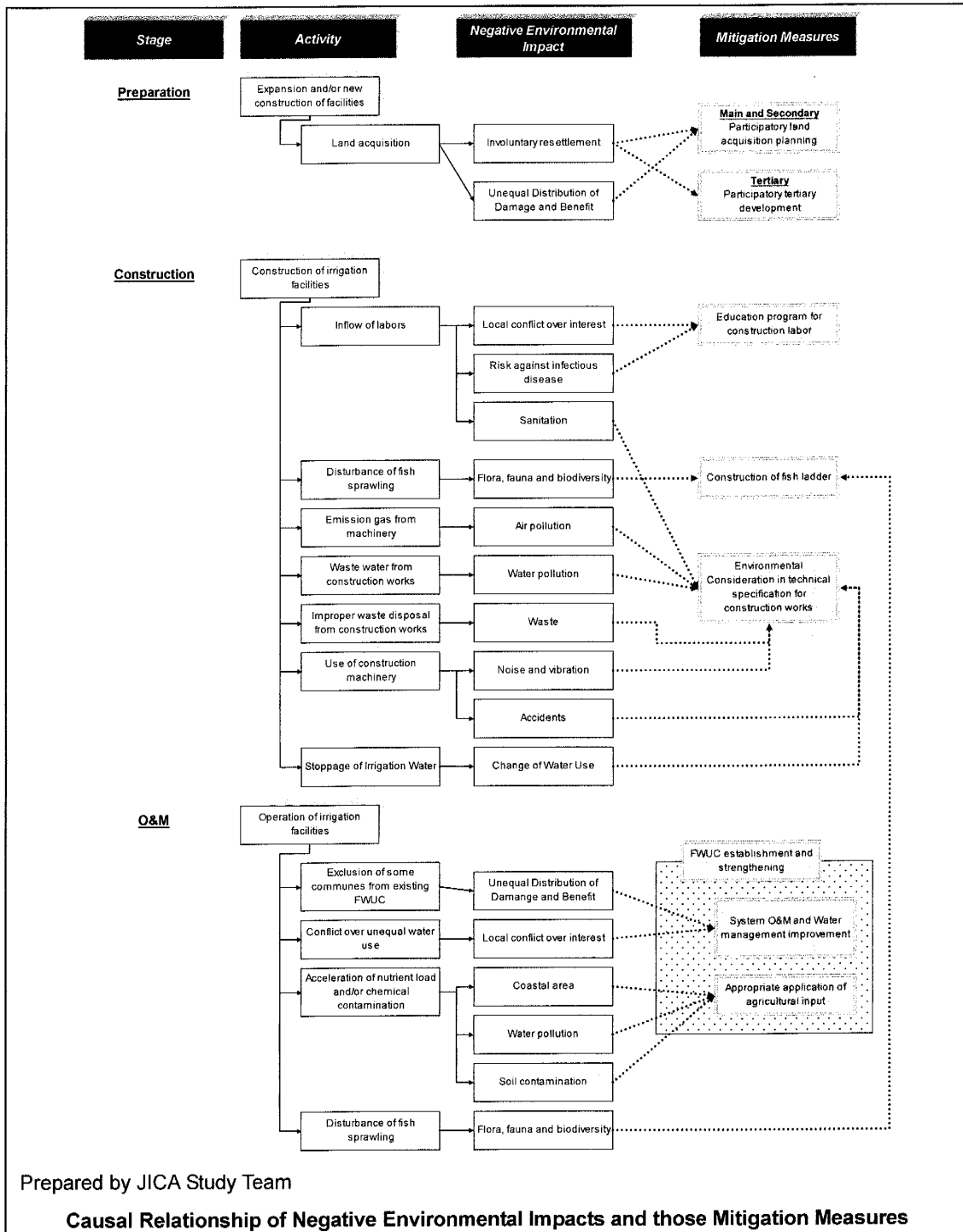

On the basis of the result of IEIA, this chapter outlines proposed mitigation measures required to mitigate or eliminate adverse impacts where identified likely arise in (i) preparation stage, (ii) construction stage and O&M stage. Certain other measures that could enhance environmental quality are also discussed.

(1) Preparation Stage

(i) Involuntary Resettlement and/or Land Acquisition

Land acquisition is an important and a sensitive matter for irrigation project and the Damnak Ampil sub-project is not left out. In general, the sub-project aims at the rehabilitation of existing irrigation and drainage facilities, therefore, there will be no significant resettlement and/or land compensation necessary for its implementation. In addition, the sub-project dose not expect to have specific impacts on ethnic minority under the irrigation command area, therefore, it does not require preparation of the plan for consideration of an ethnic minority.

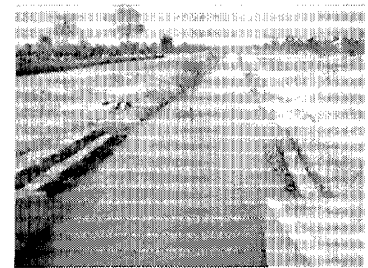

Main Canal Constructed by MOWRAM in 2006, Not Necessary to be Rehabilitated (February 2nd, 2008)

Construction of main canal will not need land acquisition since the canal was newly rehabilitated and constructed by MOWRAM in 2006 having sufficient capacity to cover proposed command area. On the other hand, land acquisition necessary under the sub-project is, in particular, for the construction of: (i) secondary facilities and (ii) tertiary facilities, which needs to consider different approach.

Main and secondary level facilities – Participatory Land Acquisition Planning

Activity
Expansion and/or new construction of facilities (Main, secondary and sub-secondary canals) and those related facilities
Affected area and people
25.3 ha, approximately 444 households along the alighment of main and secondary level facilities
Negative environmental impact anticipated
<u>Involuntary resettlement and/or land acquisition</u>
Land acquisition will be necessary for the expansion and/or new construction of irrigation and drainage facilities as well as inspection roads along main and secondary canals, which will be of varying length and width among the level of canals and drains based on the size of command areas. Preliminary estimate of the necessary areas for the acquisition is as follows:
Main canal: -
Secondary canal: 7.6 ha (approximately 191 households)
Main drain: -
Secondary drain: 17.7 ha (approximately 295 households)
Corrector drain: -

Total	25.3 ha (approximately 444 households) <p>“Unequal distribution of damage and benefit” would be anticipated from the following view point: Damnak FWUC has been established and under registration process in Damnak Ampil sub-project, the organization of which includes downstream communes although there are no activities observed at present. Proposed plan, however, covers only upstream existing portion originally constructed by MOWRAM in 2006, and the downstream will be left for expansion in the future stage.</p>
Mitigation measures	<ul style="list-style-type: none"> ➤ The alignment of the proposed canals should follow the original canals as facilities so as to minimize land acquisition. ➤ It is of necessity to facilitate coordination among Inter-ministerial Resettlement Committee (IRC) and local-based authorities to properly carry out: (i) asset valuation at replacement cost and resettlement cost estimation to be affected through the implementation and (ii) compensation measures. ➤ Compensation rate for land loss and value of land based on field interview carried out in June 2008 is US\$ 0.3/m² for agricultural field. This replacement cost will be updated by MOWRAM prior to the implementation of the sub-project based on market price. ➤ Step-wise consensus building needs to be conducted with affected people and communities through workshop for: (i) canals and drains alignment, (ii) compensation measures and (iii) support necessary for sustainable O&M. ➤ Although not necessarily physical compensation needed in accordance with the land-related laws and regulations, consensus building should be made with farmers currently doing cultivation in the main canal. ➤ Training program would be effective for IRC members, particularly MOWRAM and PDOWRAM staff, curriculum of which primarily consist of: (i) participatory and community development skills, (ii) conflict resolution and mediation, (iii) risk assessment and management, and (iv) resettlement planning. <div style="text-align: right; margin-top: 20px;">  <p style="text-align: center;">Secondary Canal to be Rehabilitated and Extended (February 2nd, 2008)</p> </div>
Stakeholders	<ul style="list-style-type: none"> ➤ Inter-ministerial Coordination Committee (IRC) ➤ MOWRAM ➤ PDOWRAM ➤ Commune Council ➤ Village Development Committee ➤ Representative of farmers ➤ Affected Farmers

Prepared by JICA Study Team

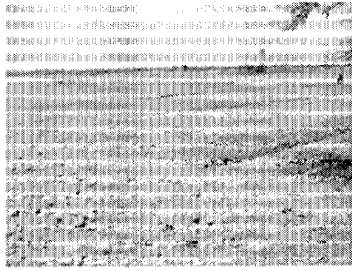

No Tertiary Canals Developed at Present
(February 8th, 2008)

Currently, no tertiary level facilities have been developed in the sub-project command area. In order to materialize effects of facilities rehabilitation and development at the main and secondary level, construction of tertiary canals and drains together with inspection roads needs to be concurrently promoted. Different from main and secondary level facilities, however, tertiary level development is the responsibility of local authorities and communities technically supported by MOWRAM and PDOWRAM. Therefore, local-based consensus building, planning and implementation is of great

importance for the development of tertiary level facilities.

Tertiary level facilities – Participatory Tertiary Development

Activity
Construction of tertiary level facilities (Canals and drains)
Affected area and people
47.7 ha, approximately 681 households along the alignment of tertiary level facilities
Negative environmental impact anticipated
<u>Involuntary resettlement</u>
The necessary land acquisition for the construction of tertiary facilities is estimated as follows:
Tertiary canal: 31.8 ha (approximately 454 households)
Tertiary drains: 15.9 ha (approximately 227 households)
Total 47.7 ha (approximately 681 households)
Note: The area includes inspection roads along the canals.
Mitigation measures
<ul style="list-style-type: none"> ➤ Appropriate procedure for tertiary development is essential including compensation measures for affected farmers. ➤ The canals and drains will be proposed through joint-walk-through survey among engineers of PDOWRAM, affected farmers and local authorities such as commune council and village development committee. The alignment will follow existing bund wherever possible so as to minimize land acquisition. ➤ Cooperation among local communities such as commune council and village development committee needs to be enhanced. ➤ Training program would be required for the members of local authorities particularly commune council, village development committee and representative of farmers, curriculum of which consist of the subjects in mentioned in “the main and secondary facilities” plus: (i) facilitation skills, (ii) preliminary design of tertiary level facilities including canals, drains and appurtenant structures, and (iii) monitoring and evaluation of the activities at the local level.
Stakeholders
<ul style="list-style-type: none"> ➤ MOWRAM

- PDOWRAM
- Commune Council
- Village Development Committee
- Representative of farmers
- Member farmers of tertiary blocks

Prepared by JICA Study Team

(2) Construction Stage

In the construction stage, negative environmental impacts to be expected for sub-project implementation are: (i) local conflict over interest, (ii) risk against infectious disease, (iii) impact to flora, fauna and biodiversity, (iv) air pollution, (v) water pollution, (vi) waste disposal, (vii) noise and vibration and (viii) accidents, those of which are mutually and closely correlated.

(i) Local Conflict Over Interest and Risk Against Infectious Disease

Education Program for Construction Labor

Activity
Construction of Irrigation and Drainage facilities (Canals and drains)
Affected area and people
In and around sub-project area
Negative environmental impact anticipated
Because of the inflow of construction workers from outside of sub-project area, following negative impact is expected: (i) deterioration of security, (ii) deterioration of sanitary condition and (iii) increase of infectious disease.
Mitigation measures
<ul style="list-style-type: none"> ➤ Education program should be carried out for the workers in order to maintain security, sanitary condition and to follow community rules. ➤ Public meeting should be organized for community people so as to explain about construction schedule. ➤ Information on construction works is disseminated to the communities through poster and/or brochure to raise awareness. ➤ Technical specification of the construction works needs to include obligation of contractors for the preparation of appropriate base camp and facility for construction workers.
Stakeholders
<ul style="list-style-type: none"> ➤ Contractors ➤ Construction Workers ➤ Community People



Public Meeting Organized with the Community Members (February 7th, 2008)

- Local Authority]
- MOWRAM
- PDOWRAM

Prepared by JICA Study Team

(ii) Flora, Fauna and Biodiversity

Construction of Fish Ladder

Activity
Rehabilitation of Damnak Ampil Weir
Affected area and people
Fishers presently doing fishing in Pursat River
Negative environmental impact anticipated
The weir was constructed in 2006 by MOWRAM. The weir are not equipped with fish ladder, therefore, there would be concerns to affect fish sprawling in the Pursat River, which would in the future reduce fish yield.
Mitigation measures
<ul style="list-style-type: none"> ➤ In conformity with the rehabilitation of gate, the construction of fish ladder needs to be considered in order to maintain downstream flows and upstream migration to the sustainability of fish catches as well as ecological resources. ➤ Features to be taken into account before implementation of the sub-project include the biological and physiological characteristics of migrating species as well as the course, speed, width and depth of the fish pass. Previous lessons for the effectiveness of fish ladder constructed in other projects needs to be reviewed and assessed such as the fish path constructed for Stung Chinit Reservoir under the Stung Chinit Irrigation and Rural Infrastructure Project (ADB).

No Fish Ladder Equipped with Damnak Ampil Weir (February 2 nd , 2008)
Stakeholders
<ul style="list-style-type: none"> ➤ MOWRAM ➤ PDOWRAM ➤ Community People particularly Fishers ➤ Local Authority

Prepared by JICA Study Team

(iii) Sanitation, Water Use, Air Pollution, Water Pollution, Waste, Noise and Vibration and Accidents

Environmental Consideration in Technical Specification for Construction Works

Activity
Rehabilitation and/or Construction of Irrigation and Drainage facilities

Affected area and people
In and around sub-project area
Negative environmental impact anticipated
<p>All the negative impacts are directly related with the construction works, particularly the operation of construction machinery during construction works. Potential adverse impacts are as described respectively as follows:</p> <p>Sanitation: Inflow of construction labor would increase possibilities on sanitary deterioration in and around sub-project area by disposing of domestic waste.</p> <p>Water Use: Cropping during construction period will be affected if irrigation water supply is completely terminated. In addition, although current percentages are limited as refer to section 4.3.6, community members using river water for drinking and domestic use would be affected when river water flow change due to temporary works such as diversion and coffer dam for canal construction.</p> <p>Air pollution: Emission gas will be exhausted by the transportation of construction machinery such as excavator, bulldozer, watering lorry and so forth.</p> <p>Water pollution: In particular, water in the downstream of the sub-project will be affected by water pollution through improper dumping of construction waste. In addition, poor de-watering from, for example, borrow areas affect water quality in surrounding areas, for which appropriate measures needs to be taken.</p> <p>Waste disposal: Solid waste will be created from waste from construction materials and machinery. There needs to be appropriate management measures put in place for waste to be generated.</p> <p>Noise and vibration: Construction machinery will create noise and vibration during construction. In particular, site of intake and beginning of main canal is the nearest to the village which needs to be considered.</p> <p>Accident: Through the operation of construction machinery, consideration to the mitigation of accidents in and around sub-project areas especially access between national road No. 5 and the sub-project site needs to be carefully carried out.</p>
Mitigation measures
<ul style="list-style-type: none"> ➤ In the technical specification of the construction works, obligation of the contractors for the consideration of: (i) water use for agriculture, drinking and domestic use, (ii) air pollution, (iii) water pollution and treatment, (iv) waste disposal, (v) noise and vibration and (vi) accidents needs to be clearly specified. Sample specification with the preliminary level is introduced afterward. ➤ On the basis of specification, education programs for construction workers should be carried out under the obligation of the contractors. ➤ Periodical patrol and monitoring needs to be carried out by the staffs of PDOWRAM and local authorities to ensure environment-friendly ways in construction works.
Stakeholders
<ul style="list-style-type: none"> ➤ PDOWRAM

- Local Authority
- Contractors
- Community People
- MOWRAM

Prepared by JICA Study Team

Technical specification for the construction works needs to consider matters in the table below to mitigate negative environmental impact in and around the sub-project site during construction period. The contents consist of: (i) general, (ii) earth work, (iii) care of water, (iv) sod facing, (v) site clearing, and (vi) operation of temporary labor camp.

Subjects to be Considered for Environmental Impact Mitigation for the Construction Works

No.	Clause	Sub-Clause
I-01	General	-
I-02	Earth Work	✓ Safeguarding excavated and natural slope ✓ Spoil disposal
I-03	Care of Water	✓ Design ✓ Dewatering during construction ✓ Drinking and irrigation water supply during construction
I-04	Sod Facing	-
I-05	Site Clearing	✓ Disposal of material
I-06	Operation of Temporary Labor Camp	✓ Operation, maintenance and removal of camp

Prepared by JICA Study Team

Box-1: Subjects to be considered for environmental impact mitigation for the construction works

ENVIRONMENTAL CONSIDERATION FOR THE CONSTRUCTION WORKS

I-01 GENERAL

Environmental consideration necessary for the civil works consisting of construction of intake weir, rehabilitation of canals and related structures are specified in this Chapter. The Contractor shall perform the works with environmentally sound as specified or as directed by the Consultant. The Contractor shall prepare and submit to the Consultant for his approval the construction program of this Chapter for respective structures under each work component prior to commencement of the works.

I-02 EARTH WORK

I-02-1 Safeguarding Excavated and Natural Slope

The Contractor shall be responsible for the stability of the excavated slopes and of natural slopes affecting or affected by the Work. Stockpiles shall not be formed within such distances behind excavated or natural slopes as should thereby reduce the stability of the slope. The Contractor shall be responsible for the stability of all slopes to spoil tips and of

natural slopes affected by spoil tips or by borrowing.

The Contractor shall be responsible for carrying out all remedial works including any necessary backfilling and regarding as in the opinion of the Consultant may be necessary to stabilize any incipient or actual failure or to reinstate any actual failure in any excavation, spoil embankment and/or natural slope affected by any temporary or permanent work.

I-02-2 Spoil Disposal

Excavated materials from the works for re-use are to be placed directly in its final position, and may be stacked on site as approved by the Consultant. Spoil unfit for re-use shall be removed to the spoil areas, which may be borrow areas or other areas after extracting earth, approved by the Consultant. All spoil areas shall conform to the following requirements:

- (a) Drainage shall not be polluted or obstructed.
- (b) Debris shall not be left where it may be carried by water to the dam and intake, or into the canal.
- (c) On completion of the Work the spoil areas shall be graded to the profiles and contours as approved by the Consultant, shall be of tidy appearance, and shall be such as will not detract from the general amenity of the surrounding area.
- (d) Any topsoil covering the intended spoil area should be removed and stockpiled for use in the restoration work described in (c).

I-03 CARE OF WATER

I-03-1 Scope of Work

The work specified in this Clause is related with the construction of intake weir, ditches, and sumps and other protective works for the care of surface water during construction to ensure that the Work will be carried out in the dry condition, to mitigate dissemination of water-borne disease through the Project, and to minimize adverse impact on water use by communities in and around the site.

I-03-2 Design

All coffering as well as methods of execution of the Work shall be designed in detail by the Contractor and subject to the approval of the Consultant. The Contractor is fully responsible for a proper design, construction, maintenance, and removal of coffering.

The Contractor shall prepare the program of each cofferdam containing general design drawings, working procedure, time schedule and dewatering, and shall be submitted to the Consultant for his approval at least 7 days prior to commencement of any work under this Clause. These documents shall include but not limited to, the layout and the design calculation of cofferdams.

All works of permanent structures shall be performed in areas free from water, unless otherwise specified, or authorized by the Consultant.

The Contractor shall repair at his expense any damage to foundations, to any structure

shown on the Drawings and to construction facilities for the Work including those in this Clause, which is caused by floods, surface runoff water, or failure of any part of the diversion or protective work in the Project.

I-03-3 Dewatering during Construction

The work shall include the design and construction of pits, trenches, facilities for dewatering equipment including furnishing, installation, operation, maintenance, depreciation, relocations, and removal required for the execution of all works (excavation, embankment, slope protection, concreting, pilling, etc.). The Contractor shall arrange sufficient number of sand pumps and/or so capable pumps for dewatering of the works, particularly intake weir, in considering of the geological constitution and surroundings. The Contractor shall arrange the pump as new as possible in order to avoid trouble during operation which may cause the delay of construction.

As soon as the drainage facilities designed by the Contractor and approved by the Consultant are completed, they can be used by the Contractor who will be responsible for the maintenance of these facilities until the completion of the respective Works or section of Works.

I-03-4 Drinking and Irrigation Water Supply during Construction

All the works shall be performed in consideration of current water use of community members in the site. The Contractor shall prepare mitigation measures for minimization of any adverse impact on current water use by community members in the site incurred by the construction works, as directed by the Consultant.

I-04 SOD FACING

The Contractor shall perform sod facing on the slopes of embankment or excavation if it is shown on the Drawings or directed by the Consultant in order to protect the slopes from erosion.

The sod shall have healthy living stem and roots and obtained from heavy thickly matted soil in the approved locations having similar growing conditions. The sod to be used shall be free of weeds or undesirable plants. When the sods are cut, grass height shall not exceed 10 centimeters and they shall have soil adhering to the roots when planted. The sod shall be planted within 24 hours after cutting in continuous lines on the slopes of the embankment or excavation in close contact and then tamped firmly in place. Immediately after placing, the sodded slopes shall be watered and kept moist until plant growth has been re-established.

The sod facing area of the slope shall be covered more than 80 percent of the area of the slope.

The Contractor shall prepare program of sod facing work basing on his demonstrable background of sod planting and submit it to the Consultant for the approval.

The Contractor shall protect the sodded area during the time when vegetation is becoming

established. If objectionable weeds or other undesirable growths smother the planted species such vegetation shall be removed from the area.

I-05 SITE CLEARING

I-05-1 Scope of Work

This Clause covers all works requiring disposal of waste materials created from the construction works.

I-05-2 Disposal of Material

The material removed in clearing and/or demolishing operations shall be burned, or otherwise disposed of, as approved by the Consultant.

All materials to be burned shall be piled neatly and when in a suitable condition shall be burned completely. Piling for burning shall be carried out in such a manner and in such a locations as to create the least fire risk.

All burning shall be so thorough that the cleared materials will be reduced to ashes. The Contractor shall at all the time take special precautions to prevent fire from spreading and shall have available at all the time suitable equipment and supplies, for use in preventing and fighting fires.

All the materials creating harmful gas, if burned, shall be disposed appropriately. The Contractor shall prepare plans on procedures of disposal and get approval from the Consultant prior to any operations.

I-06 OPERATION OF TEMPORARY LABOR CAMP

I-06-1 Scope of Work

The Clause covers temporary labor camp which the Contractor shall rent or construct as he may require for his own use and for his labor employed for the Works. The Contractor shall operate such camps so as not to disturb any environmental conditions in the project areas.

I-06-2 Operation, Maintenance and Removal of Camp

Operation and maintenance of the Camp including all services and access roads shall be entirely the responsibility of the Contractor and at his expense. The Contractor shall provide all garbage and refuse collection and disposal at appropriate frequency as approved by the Consultant.

Upon completion of the Works, the Contractor shall remove all facilities and temporary structures built by him as part of his camp, fill in all excavated areas, remove all refuse, debris and objectionable material so that the camp areas will be left in clean and neat condition, to the approval of the Consultant.

(3) O&M Stage

Adverse environmental impacts anticipated during O&M stage are related with increased and improved irrigation water use after implementation of the sub-project. Mitigation would be

FWUC establishment and strengthening, which are sub-categorized into two: (i) system O&M and water management improvement and (ii) appropriate application of agricultural input. They are relevant to overall O&M and agricultural support, therefore, activities proposed here should be carried out in comprehensive support programs.

(i) Local Conflict over Interest

System O&M and Water Management Improvement

Activity		
Operation of Rehabilitated and/or Constructed Irrigation and Drainage facilities		
Affected area and people		
In and around sub-project area including downstream areas		
Negative environmental impact anticipated		
<p>Unequal water allocation would be anticipated if proper water management is not carried out in the sub-project command areas. This issue is related not only within command area but also with other irrigation systems particularly located in the downstream of the Damnak Ampil sub-project. In addition, irrigation water is allocated to downstream sub-project: Wat Loung and Wat Chre through main and secondary canals of Damnak Ampil. Conflict among those sub-projects would happen if water distribution is not properly carried out.</p>		
Mitigation measures		
<ul style="list-style-type: none"> ➤ Farmer Water User Community (FWUC) needs to be established and strengthened to carry out appropriate irrigation system O&M and water management. ➤ FWUC establishment should be through stepwise approach as stipulated in PIMD Module: (i) initial Meeting to identify constraints and opportunities within communities, (ii) identify irrigation area and potential members for FWUCs through Participatory Rural Appraisal (RRA), (iii) consensus building among FWUCs for activities plan, (iv) preparation of FWUC statute and by-laws, (v) establishment of FWUCs and selection of leaders, (vi) capacity building of FWUCs for preparation of irrigation service plan, (vii) finalization of irrigation service plan, (viii) preparation and adoption of management transfer agreement, (ix) rehabilitation of systems through FWUCs participation and (x) provision of periodical support services to continue FWUC capacity building based on lessons learned from above activities. ➤ Training on system O&M and water management needs to be carried out, contents of which are briefed as follows: 		
Category	Sub-category	Training Items
System O&M	Community Participatory O&M and Rehabilitation	<ul style="list-style-type: none"> • Community participatory rehabilitation (Awareness program, planning, designing, contract management, financial management and construction management) • Maintenance planning • Establishment of O&M fund
Water Management	Proper Water Management at Tertiary level	<ul style="list-style-type: none"> • Awareness on water management • Preparation of irrigation schedule • Gate operation, monitoring (discharge measurement, recording and reporting), rotational irrigation & role gate operator

	<ul style="list-style-type: none"> • Drainage improvement • Participatory M&E for water management • Conflict resolution with other systems
Stakeholders	
<ul style="list-style-type: none"> ➤ MOWRAM ➤ PDOWRAM ➤ Community People including those of downstream irrigation systems ➤ Local Authority ➤ NGOs, if necessary 	

Prepared by JICA Study Team

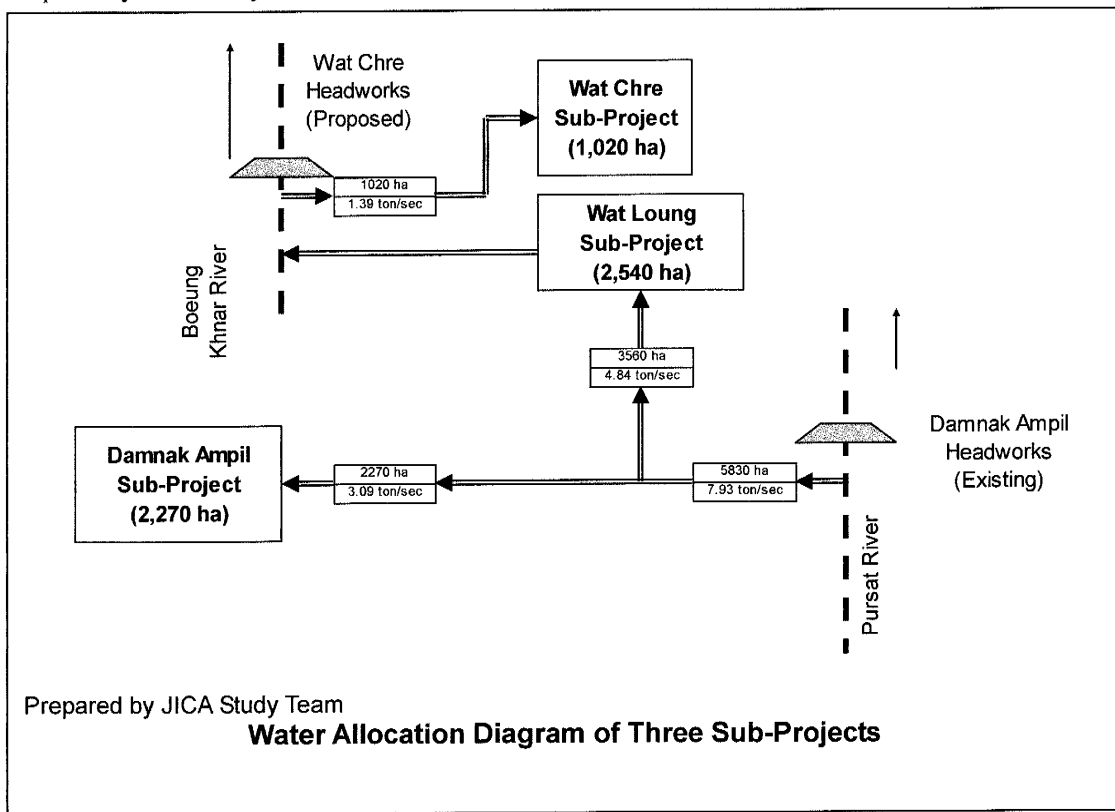

(ii) Coastal Area Pollution, Water Pollution, and Soil Contamination

Appropriate Application of Agricultural Input

Activity
Implementation of irrigated agriculture using Rehabilitated and/or Constructed Irrigation and Drainage facilities
Affected area and people
In and around sub-project area including downstream areas
Negative environmental impact anticipated
Good quantity of the irrigation water (high oxygen levels, low nutrient and dissolved salts concentration) is not conducive to excessive growth of algae and water weeds, and will neither lead to soil salinization problems. Excessive use of these are known to harm the balance of

nature, damage aquatic life, cause eutrophication and create problems to downstream water users as well. With the expected transfer of improved farming technology and the expansion of the arable land based on the rehabilitation of irrigation facilities, it would encourage farmers to use higher level of agro-chemicals and fertilizers so as to ensure higher agricultural productivity at a future point of time. Adverse impacts on water quality in the downstream of irrigation systems needs to be considered, particularly nutrient load and/or chemical contamination in the water.

Mitigation measures

- It is proposed to carry out a support program for appropriate farming particularly chemical and fertilizer application, and processing of compost by farmers.
- Pesticides in Cambodia are classified into three categories: (i) banned, (ii) restricted and (iii) permitted by the announcement of MAFF, the criteria of which is based on WHO.³ An awareness among farmers in the short-term on the hazards of using toxic chemicals will be created. Community-based mutual checking systems should be established among FWUC members for proper chemical and fertilizer application on this guideline basis supported by extension agent.
- Integrated pest management (IPM) will be introduced in a step-wise manner on methodology with the active involvement of relevant organizations (PDA, PDOWRAM and local authorities).
- Periodical water quality monitoring should be carried out within the canals in the command area and downstream areas by PDOWRAM.



On-site Water Quality Analysis along existing Secondary Canal (June 12th, 2008)

Stakeholders

- MOWRAM
- MAFF
- PDOWRAM
- PDA
- Community People including those of downstream irrigation systems
- Local Authority

Prepared by JICA Study Team

(iii) Flora, Fauna and Biodiversity

An impact on flora, fauna and biodiversity is to be caused due to disturbance of fish sprawling in the Pursat River. As having already explained in the previous section, construction of fish ladder needs to be considered during preparation and construction phase in appropriate plan, design and construction process. In addition, effectiveness of fish ladder and fish yield should be monitored and evaluated in the O&M stage by local agencies and communities.

³ The announcement No. 598 (December 15th 2003) issued by MAFF stipulated that there are respectively: (i) 116 nos. of banned, (ii) 40 nos. of restricted and (iii) 136 nos. of permitted pesticides.

7.2 Environmental Management and Monitoring Plan

In the previous sections, seven measures are proposed in order to mitigate adverse environmental impact from social and natural view points:

Preparation Stage

- Participatory land acquisition planning for main and secondary facilities development,
- Participatory tertiary development,

Construction Stage

- Education program for construction labors,
- Construction of fish ladder,
- Environmental consideration in technical specification for construction works,

O&M Stage

- System O&M and water management improvement, and
- Appropriate application of agricultural input.

As for the environmental monitoring, two plans are proposed: (i) participatory land compensation process for tertiary development and (ii) soil and water quality monitoring. Both of them are involved in the mitigation measures under the sub-project implementation. And they should be monitored in the long-term in order to materialize project effect through social and natural environment-friendly manner.

(1) Participatory Land compensation Process for Tertiary Development

Land compensation for the construction of main and secondary level will be the responsibility of the Government with IRC, the role of which is determination of entitlements, value of the lands and follow-up appropriate compensation process through information disclosure, detailed compensation planning and public consultation. The process of land acquisition for tertiary level development, however, has not been stipulated at the Central Government level. Instead, they are the responsibility on local government particularly commune councils.

Land acquisition would be sensitive issues. And there is no official process of land acquisition at tertiary level stipulated in any regulations, therefore, careful design of the process needs to be carried out so as to ensure sustainability of the project in sociologically suitable way. In this process, full public participation and meaningful consultation with the people and communities who may have potential adverse impacts from development activities is one of the important keys to success. Preliminary idea on land acquisition and compensation process at tertiary level is, therefore, illustrated as follows and explained afterward:

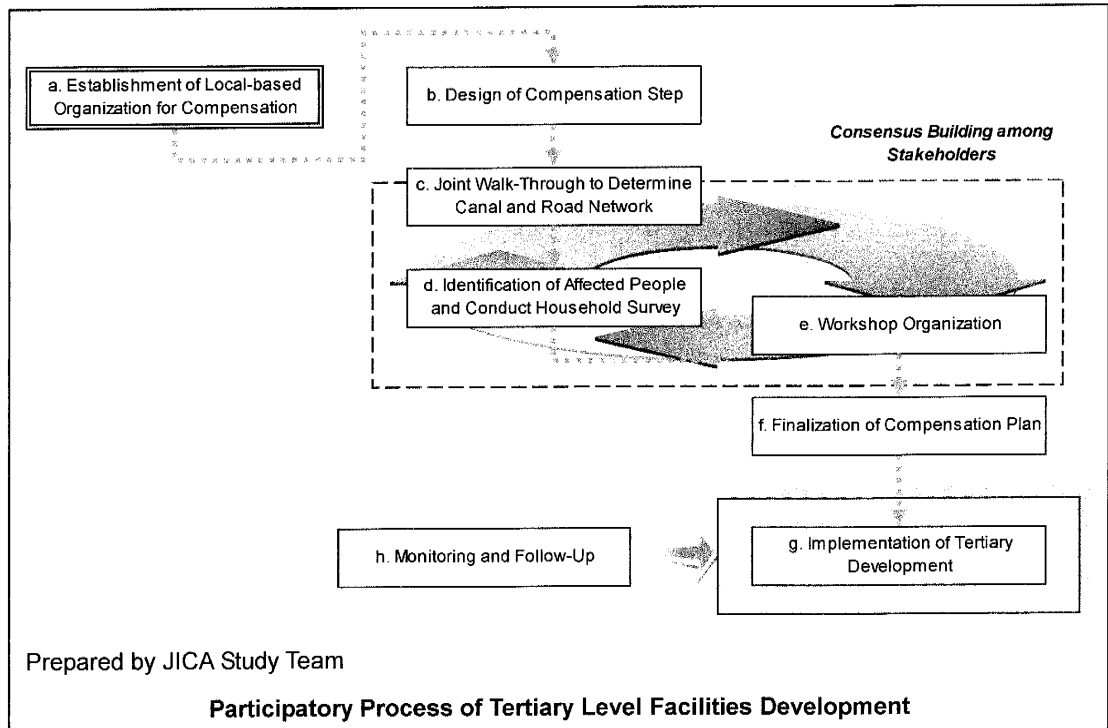

- a. **Establishment of local-based organization for compensation:** Locally-based compensation committee should be established in charge of tertiary level land acquisition consisting of PDOWRAM, PDA, Provincial Department of Land Management, Urban Planning and Construction (PDLMUPC), Commune Council, Village Development Committee, FWUC etc.
- b. **Design of compensation step:** Among committee members, compensation step is discussed and designed taking land tenure and local economic conditions into consideration. Rough idea on tertiary level canal, drain and road alignment is discussed as follows.
- c. **Joint walk-through to determine canal and road network:** Joint walk-through is carried out involving PDOWRAM engineer, representatives from village and farmers to determine optimum canal and road network, process of which needs both social and technical consideration. NGOs familiar to the Damnak Ampil Sub-Project can be also resource persons to facilitate this process.
- d. **Identification of affected people and conduct household survey:** This step is coherent with joint walk-through in the preceding step. Through joint walk-through survey using designed checklist, affected areas are identified, therefore, affected people are confirmed. Socio-economic survey, then, is conducted to collect information on socio-economic conditions, their opinions, impacts by land acquisition etc. Consensus among affected people should be built through this process.
- e. **Workshop organization:** Public consultation and information disclosure would be of critical importance in land acquisition as well as tertiary development planning. Therefore, draft plan is disclosed to get feed-back from stakeholders by organization of

the workshop. Affected asset valuation is also agreed through this process, if any, although physical compensation is not stipulated in the regulation for tertiary development.

- f. **Finalization of compensation plan:** Land acquisition, compensation as well as tertiary development plan are finalized on the basis of stakeholders' opinion in the workshop.
- g. **Implementation of tertiary development:** Based on the implementation plan agreed in the preceding steps, tertiary development is carried out including land acquisition and construction.
- h. **Monitoring and follow-up:** Compensation committee is responsible for the monitoring during the implementation of land acquisition. In particular, progress of tertiary development is periodically monitored by the committee.

(2) Water and Soil Quality Monitoring

In the Battambang Province, water quality monitoring has been carried out only at Bac Plea station of Battambang River since August 2004 by the Water Quality Analysis Office of the Hydrology and River Works Department under MOWRAM. No monitoring has not been conducted by PDOWRAM in and around the sub-projects including the water source, the Moug Russey River.

Training of farmers for appropriate application of chemicals and fertilizer are proposed to be supported under agricultural support program. In addition, a regular monitoring of soil and water quality needs to be concurrently carried out. The index of soil and water quality monitoring framework are tabulated as follows:

Soil and Water Quality Monitoring for the Projects

No.	Indicators	Method	Frequency	In-Charge
1.	pH	pH meter	Two times a year (dry and wet season respectively)	PDOWRAM/PDOE
2.	Electric Conductivity	EC meter		PDOWRAM/PDOE
3.	DO, Coliform, Nitrite, BOD, Total Nitrogen	Gas membrane electrodes		MOWRAM/PDOWRAM/PDOE
4.	Total Phosphorous	Spectrophotometer		MOWRAM/PDOWRAM/PDOE
5.	Metals, Nutrients, COD, Total Organic Carbon	Colorimeters		MOWRAM/PDOWRAM/PDOE

Prepared by JICA Study Team

In this chapter, environmental impact mitigation measures and monitoring plan is described on the basis of negative impact identified. The timeframe of proposed environmental management-related activities is depicted as follows:

	1st Year	2nd Year	3rd Year	4th Year	5th Year	6th Year
Sub-Project Implementation						
Design	▨					
Construction		▨				
O&M					▨	▨
Environment Management Activities						
<i>Participatory Land Acquisition Planning (Main and Secondary Facilities)</i>						
- Preparation of Draft Land Acquisition Plan among MOWRAM through consultation with IRC						
- Stakeholder Workshop	△	△				
- Socio-economic Survey		△				
- Valuation of Affected Asset			△			
- Compensation						
- Monitoring			▨			
<i>Participatory Tertiary Development</i>						
- Establishment of Local-based Organization for Compensation	△					
- Preparation of Draft Land Acquisition Plan		△				
- Socio-economic survey			△			
- Stakeholder Workshop				△		
- Finalization of Compensation					△	
- Implementation of tertiary development						▨
<i>Education Program for Construction Labor</i>						
- Clause for the provision of appropriate base camp						
- Stakeholder Workshop			△			
- Education Program for Labor organized by the Contractor			△	△	△	
- Monitoring						▨
<i>Construction of Fish Ladder</i>						
- Survey of biological and physiological characteristics of migrating species						
- Judgment of Necessity	△					
- Design						
- Construction						
- Monitoring of its Effectiveness and Rectification, if any						▨
<i>Environmental Consideration in Technical Specification for Construction Works</i>						
- Preparation of Tender Document						
- Tendering						
- Monitoring						▨
<i>System O&M and Water Management Improvement</i>						
System O&M						
- Awareness Program		△				
- Establishment of FWUC			△			
- Preparation of FWUC By-Laws				△		
- O&M Planning						
- Establishment of O&M Fund						
- Implementation of System O&M						
- Monitoring						▨
Water Management						
- Awareness Program						
- Training of Water Management through the Application of Improved Water Management						
- Regular Monitoring of Water Management						▨
<i>Appropriate Application of Agricultural Input in parallel with Agricultural Support Activities</i>						
- Agriculture Support Program						
- Water Quality Monitoring			△	△	△	△
- Soil Quality Monitoring					△	△

Prepared by JICA Study Team

General Timeframe of Environment Management Activities (Damnak Ampil Sub-Project)

CHAPTER 8 COMPARISON BETWEEN WITH AND WITHOUT PROJECT

8.1 Comparison Between “With” and “Without” Conditions

Comparison of “With” and “Without” projects proposed is tabulated as follows:

Comparison between “With” and “Without” Conditions

Aspect	Without Projects	With Projects
Resource Mobilization (Water and Land)	<ul style="list-style-type: none"> Irrigation water is quite limited. Ineffective resource utilization for irrigation is practiced through ineffective irrigation water management, poor O&M of facilities with insufficient support. 	<ul style="list-style-type: none"> Irrigation water increase for agriculture through improved headworks and rehabilitated canals. Hydrology and meteorology monitoring system is strengthened to prepare effective irrigation service plan and to effectively carry out river basin management. Overall, effective resource mobilization for irrigation sector is materialized.
Agriculture	<ul style="list-style-type: none"> Cropping area under the Damnak Ampil Sub-project is only 500 ha with limited irrigation water. Paddy yield remains low ranging from 1.5 t/ha (rainfed condition) to 2.5 t/ha (supplemental irrigation-transplanting in the dry season). Upland farming is negligibly small. 	<ul style="list-style-type: none"> Cropping area under the Sub-Project increases to 2,270 ha with irrigated conditions, therefore, agricultural productivity increase. Yield is expected to reach 3.3 t/ha under normal irrigated conditions contributing to increase of farmers’ income. Upland farming is introduced contributing to the promotion of value-added agriculture.
Institution	<ul style="list-style-type: none"> Although FWUC has been established and under registration process, awareness among farmers are still low at present. O&M of irrigation systems through group collaborative action is still weak. 	<ul style="list-style-type: none"> FWUCs are re-organized and strengthened for carrying out O&M through supporting program. Coordination among local organizations is expected to be strengthened to utilize effective resource mobilization.

Prepared by JICA Study Team

8.2 Comparison of Potential Negative Impacts Between “With” and “Without” Project

Potential negative environmental impacts are analyzed under “With” and “Without” Projects implementation as summarized in the table below:

Comparison of Potential Negative Impact between “With” and “Without” Projects

Potential Impact	Without	With	Remarks
Social Environment			
1 Involuntary Resettlement	X	-/C	Land acquisition necessary for construction of main, secondary and tertiary facilities
2 Local Economy (Employment and Income Generation)	-/A	+/A	Effective resource use materialization with better irrigation O&M
3 Land Use and Resource Mobilization	-/A	+/A	Irrigation water increase
4 Social capital and Traditional Institutions	-/A	+/A	Improved by means of FWUC support program

Potential Impact	Without	With	Remarks
5 Social Infrastructure and Services	-/A	+/A	Improved irrigation rehabilitation
6 The poor, indigenous and minority group	-/A	X	Population pressure in future
7 Unequal Distribution of Damage and Benefit	-/A	X	Population pressure in future
8 Cultural Heritage	X	X	No cultural heritage in and/or around the command area
9 Local conflict over interest	-/A	+/A	Effective resource use if mitigation measures are properly carried out
10 Water Use	-/A	+/A	Irrigation water increase by rehabilitated facilities
11 Sanitation	X	X	
12 Risk against infectious diseases	X	X	No significant impact if mitigation measures are carried out
Natural Environment			
13 Topography and Geographical Features	X	X	
14 Soil Erosion	-/C	+/B	Mitigated particularly by regulating water by rehabilitated facilities
15 Groundwater	X	X	
16 Hydrology	X	X	
17 Coastal Area such as Mangrove, Coral Reef and Tidal Area	X	X	
18 Flora, Fauna and Biodiversity	-/C	+/B	Construction of fish ladder to ease fish sprawling
19 Meteorology	X	X	
20 Landscape	X	X	
21 Global Warming	X	X	
Pollution			
22 Air Pollution	X	-/C	During construction although small impact
23 Water Pollution	X	-/C	During construction although small impact
24 Soil Contamination	X	-/C	During construction although small impact
25 Waste	X	-/C	During construction although small impact
26 Noise and Vibration	X	-/C	During construction although small impact
27 Ground Subsidence	X	X	
28 Offensive Odor	X	X	
29 Sedimentation	X	X	
30 Accidents	X	-/C	During construction

Note: - : Adverse Impact X: No Impact +: Positive Impact
A: Great Impact B: Medium Impact C: Small Impact

Prepared by JICA Study Team

Without implementing the Damnak Ampil sub-project, the livelihood of the people will most likely continue at their present levels. Each time the fertility of the plot of land comes to unproductive levels excessive intensity of production if future population pressure is considered. The implementation of the sub-project will mitigate the present instability in farming by providing irrigation water through rehabilitated facilities. It will make way for

farming in more stabilized manner, improve living standards and provide additional income. It will gradually bring about a balance in resource use and reduce land degradation.

Since the Pursat River Basin has abundant water resources, MOWRAM has a plan to extend Damnak Ampil main canal connecting with Svay Don Keo River to irrigate downstream systems that are possible from the view point of water potential. Producing sufficient rice for domestic consumption is a priority policy of the government of Cambodia. Food security will be improved through increasing rice production which is one of the more important objectives of the sub-project.

CHAPTER 9 STRENGTHENING OF INSTITUTIONAL CAPACITY FOR ENVIRONMENTAL MANAGEMENT

9.1 Organizational Structure

The Strategic Development Plan 2006-2010 (Draft) has accentuated the importance of “having a comprehensive capacity to develop and apply procedures for social and environmental impact assessment and mitigation” as shown in MOWRAM Goal 11.⁴ At present, Resettlement Unit is in charge of handling social environmental impact particularly resettlement issues associated with irrigation development projects under MOWRAM.

However, practical knowledge and experience in Environmental Impact Assessment (EIA) and environmental management remains limited.

In order to properly carry out EIA, prepare environmental management plan and pursue its implementation for irrigation development in the future, coordination is required between the Resettlement Unit under MOWRAM and EIA unit of MAFF. In addition, out-sourcing of the part of EIA work to private consulting firm should be also considered.

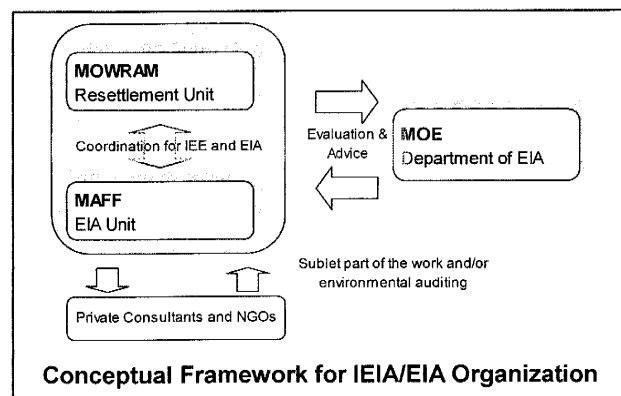

9.2 Capacity Development Plan for Environmental Management

Strengthening the staff capability of MOWRAM, PDOWRAM and village authorities in terms of environmental awareness and practical impact mitigation measures through in-service training and study visits to model areas would be important and beneficial for sustainable irrigation development and management for the Damnak Ampil sub-project. Training models such as cascading style of training where trainees at one level become trainers at the other level, and the mechanism for information shares and feedback from lower to higher levels is evident. These activities will create a different kind of institutional organization and communities which has the capacity to retain its abilities to facilitate, as well as to respond to environmental awareness and management. Training programs proposed for environmental management is as follows:

- (1) On-the-Job Training for IEIA and preparation of TOR for EIA
 - To understand procedure of IEIA and EIA on the basis Sub-Decree on Environmental Impact Assessment Process

⁴ Planning and International Cooperation Department, MOWRAM (2005), Strategic Development Plan 2006-2010 (Draft of 23 May, 2005)

- To carry out basic field environmental survey such as field interview, on-site water and soil sampling and quality analysis etc.
 - To develop IEIA capabilities through case studies of irrigation projects
 - To visit construction sites of irrigation development project
 - To prepare checklist for IEIA and carry out IEIA based on checklist
 - To execute training program and seminar for strengthening staffs' capabilities on the preparation of Terms of Reference (TOR) for EIA
- (2) Training for Environmental Impact Mitigation and Management Planning
- To clarify causal relation of environmental impact from irrigation development
 - To prepare appropriate management plan of adverse environmental impact
 - To prepare environmental monitoring and evaluation plan

CHAPTER 10 CONCLUSIONS

From the field studies, other information gathered and discussion presented in the preceding chapters, it is concluded that the Damnak Ampil Sub-project will be extremely beneficial to the communities living in the command area. There will be a better productivity and an improved livelihood if the project is to be implemented.

No serious adverse environmental impacts are predicted for the Damnak Ampil rehabilitation sub-projects since the sub-project is existing one and no large scale of expansion and/or new development is included under the component. Those adverse environmental impact identified are of a minor nature. Mitigation and enhancement measures are suggested where necessary and these will bring about an overall improvement in environmental quality. Indeed, once completed, well managed sub-project should enhance the long-term sustainability of the rural environment.

In view of the above conclusions arising out of the IEIA of the sub-projects, a full scale Environmental Impact Assessment (EIA) is not considered necessary.

Tables

Table 4.3.1 Poverty Ranking at Damnak Ampil Rehabilitation Sub-Project

Classification	Family	Percentage	1. Income		2. Asset				3. Education Level	4. Basic Human needs Satisfaction (food-rice)	5. Financial Transaction Experience
			Average Income per day (each person/ Riel)	Source of Income (main economic activity)	Land (ha)	Bicycles, motorcycles, cars, trucks, tractors, etc	TV, music, player, video, radio	Livestock			
Destitute	30 F	1.5 %	0-1000	Labors	0.5	bicycle	Small radio	0-5 chicken	Primary school drop out	Enough for 2 or 3 months	Can borrow money from farmer's group, middle men.....
Poor	1,070 F	53.5%	1,000-3,000	Labor, go to Thai border, garment factory worker	0.5-1	Bicycle, cart	Radio,	5-10 chicken	Secondary school drop out	Enough for 3 or 4	Can borrow money from micro finance, middle men
Fair	850 F	42.5%	3,000-5,000	Trader, husbandry, Working on rice field, land owner	1-2	Bicycle, cart	Radio, TV	2 or 3 cows, 1-2 Water buffalos 5-10 chicken	Secondary school drop out	Enough	Can borrow money from bank, have money to lend to neighbor....
Rich	50 F	2.5%	5,000-8,000	Money lender, Trader, land owner	>2	Bicycle, cart Motorbike,	Color TV, Radio, VCD	10-15 chicken, 2-3 pigs, 4-5 cows or buffalos	High school drop out	surplus	Have money to lend to neighbor, can borrow money from bank.....
Total	2,000 F	100%									

Table 5.2.1 Summary of Discussion on PIMD made in the Public Meeting at Damnak Ampil Rehabilitation Sub-Project

Question	Lok Sar Commune	Snam Preah Commune
How will you organize FWUC?		
Who will be a prospective leader of FWUC?	<ul style="list-style-type: none"> A leader of FWUC should be selected from a person with the capacity. The leader should be selected by the election. 	<ul style="list-style-type: none"> A leader of FWUC a person with enough capacity and dedicating himself or herself to work for community. The leader needs to be selected by election in democratic manner.
Who can be a member of FWUC?	<ul style="list-style-type: none"> Members of FWUC would include farmers getting benefit from Damnak Ampil Canal. 	<ul style="list-style-type: none"> Member of FWUC should be farmers with their fields under Damnak Ampil Irrigation Project. Such person can be members of FWUC as having commitment on following FWUC regulation
If irrigation system covers several communes, how will you organize FWUC?	<ul style="list-style-type: none"> It is required to establish general committee as higher organization so as to carry out overall supervision of all communes related with the Project. Sub-committee should be established in each commune. In addition, committee in each village needs to be established for the coordination within the village for water utilization and facilitation of connection with higher organizations. 	<ul style="list-style-type: none"> It is necessary to organize sub-committee in each village.
What kind of activities do you think required for FWUC in your project? Please explain using system layout prepared	<ul style="list-style-type: none"> Preparation of regulation, statue and by-laws of FWUC would be, first and foremost, important for FWUC. FWUC also needs to promote publicity, in order to be approved and recognized by the government. Sign agreement between service provider and water user is one of the necessary activities by FWUC. 	<ul style="list-style-type: none"> In accordance with the policy of the Government, the community members have understood that transferring responsibility on irrigation management at tertiary level from the government to the local authority will be carried out. For example, forest community, people love forest and then get benefit from the forest. Local-based action would foster similar attitude among communities toward irrigation management.

Table 6.1.1 Environmental Impact Matrix of Damnak Ampil Rehabilitation Sub-Project (1/2)

Item	Stage and Impact			Reason	Mitigation Measures	Monitoring	
	Preparation	Construction	O&M			Method	Timing
Social Environment							
1. Involuntary Resettlement	-/C	X	X	<ul style="list-style-type: none"> No significant impact will be expected since there is no large scale new expansion of the area. No land acquisition is required for main facilities while land acquisition is necessary for secondary and tertiary level canals and structures. 	<ul style="list-style-type: none"> This issue must be considered from design phase of the project. Stage-wise discussion is required on canal alignment, reservoir locations, compensation measures, support programs and so forth, which contribute to maintain living condition of farmers. <i>(Main and Secondary Facilities: Participatory Land Acquisition Planning) (Tertiary Facilities: Participatory Tertiary Development)</i> 	<ul style="list-style-type: none"> Workshop, Stakeholder meeting 	<ul style="list-style-type: none"> Preparation, Design and Construction Phase
2. Local Economy (Employment and Income Generation)	X	+/B	+/B	<ul style="list-style-type: none"> New job opportunity from construction works as well as agricultural production increase will give positive impact in the community. 	-	<ul style="list-style-type: none"> Socio-economic survey 	<ul style="list-style-type: none"> O&M Phase
3. Land Use and Resource Mobilization	X	X	+/B	<p><u>Preparation</u></p> <ul style="list-style-type: none"> Land acquisition must be considered for promoting construction of tertiary canals and structures. Consensus building should be carefully carried out. <p><u>O&M</u></p> <ul style="list-style-type: none"> Large scale area-wise expansion is not included in the component of the sub-project, therefore, there will be no significant adverse impact in land use and resource mobilization. Instead, positive impact will be expected by improved water use. 	-	<ul style="list-style-type: none"> Socio-economic survey 	<ul style="list-style-type: none"> O&M Phase
4. Social capital and Traditional Institutions	X	X	X	<ul style="list-style-type: none"> No significant impact will be anticipated. Traditional social institutional system would be carefully considered by the construction of the facilities and the change of water use. 	-	-	-
5. Social Infrastructure and Services	X	X	X	<ul style="list-style-type: none"> No significant impact will be anticipated. 	-	-	-
6. The poor, indigenous and minority group	X	X	X	<ul style="list-style-type: none"> No impact will be expected. 	-	-	-
7. Unequal Distribution of Damage and Benefit	X	X	-/C	<ul style="list-style-type: none"> Although FWUC has been established and under registration process at PDOWRAM Pursat, target area of proposed sub-project does not necessarily include all the communes in the abovementioned FWUC. 	<ul style="list-style-type: none"> Workable organizational structure of FWUC needs to be established by considering existing organization as well as proposed command area under FWUC supporting program. <i>(FWUC Establishment and Strengthening)</i> 	<ul style="list-style-type: none"> Workshop, Stakeholder meeting FWUCs strengthening program 	<ul style="list-style-type: none"> Design, Construction and O&M Phase
8. Cultural Heritage	X	X	X	<ul style="list-style-type: none"> No impact will be expected since no cultural heritages exist in the command area of the sub-project. 	-	-	-
9. Local conflict over interest	X	-/C	-/C	<p><u>Construction</u></p> <ul style="list-style-type: none"> Due to the inflow of construction labors from outside, conflict among labors and farmers are expected leading to security deterioration in the community. <p><u>O&M</u></p> <ul style="list-style-type: none"> Conflict over unequal water use would possibly happen if water distribution is not properly carried out. Three sub-projects: (i) Damnak Ampil, (ii) Wat Loung and (iii) Wat Chre are located in cascading, water of which are provided from the Pusat River. Local conflict over irrigation water would be anticipated among said three sub-projects if proper water management is not carried out. 	<ul style="list-style-type: none"> Education programs are necessary for both labors and community members to raise awareness so as to maintain security in the community during construction. <i>(Education Program for Construction Labor)</i> FWUCs should be established and strengthened to prepare irrigation service plan and to carry out its implementation. Group management skills are also necessary to share common goods in equitable manner. <i>(FWUC Establishment and Strengthening)</i> 	<ul style="list-style-type: none"> Education Programs FWUCs strengthening program 	<ul style="list-style-type: none"> Construction Phase Design, Construction and O&M Phase
10. Water Use	X	-/C	+/A	<p><u>Preparation</u></p> <ul style="list-style-type: none"> Water use for other sectors needs to be considered in the planning stage. <p><u>Construction</u></p> <ul style="list-style-type: none"> Water supply for both drinking and agriculture needs to be considered during construction stage although percentage of users' for canal water is limited. <p><u>O&M</u></p> <ul style="list-style-type: none"> Water resource utilization will be expected to be effectively carried out through the sub-project. 	<ul style="list-style-type: none"> Construction schedule is prepared taking cropping schedule under the command area into account. Drinking water is provided by alternative ways such as water tank truck. Such issues are clearly specified in the technical specification of the construction works. <i>(Environmental Consideration in Technical Specification for Construction Works)</i> 	<ul style="list-style-type: none"> Stakeholder Meeting 	<ul style="list-style-type: none"> Construction Phase
11. Sanitation	X	-/C	X	<ul style="list-style-type: none"> This would happen due to inflow of labors from outside during construction stage. 	<ul style="list-style-type: none"> It is important for Contractors to prepare proper accommodation with sanitary facilities including toilet and water supply for construction labors. Education and training program is also required to raise awareness of labors for the maintenance of sanitary conditions in and around the sub-project site. <i>(Environmental Consideration in Technical Specification for Construction Works) & (Education Program for Construction Labor)</i> 	<ul style="list-style-type: none"> Site Supervision 	<ul style="list-style-type: none"> Construction Phase
12. Risk against infectious	X	-/C	X	<ul style="list-style-type: none"> This would happen due to inflow of labors from outside during construction stage. 	<ul style="list-style-type: none"> This also requires education program to raise awareness among construction labors. <i>(Education Program for Construction Labor)</i> 	<ul style="list-style-type: none"> Stakeholder Meeting 	<ul style="list-style-type: none"> Construction Phase

Table 6.1.1 Environmental Impact Matrix of Damnak Ampil Rehabilitation Sub-Project (2/2)

Item	Stage and Impact			Reason	Mitigation Measures	Monitoring	
	Preparation	Construction	O&M			Method	Timing
diseases						• Site Supervision	
Natural Environment							
13. Topography and Geographical Features	X	X	X	• No impact will be expected in this matter.	-	-	-
14. Soil Erosion	X	X	X	• Soil erosion will be mitigated by drainage improvement.	-	-	-
15. Groundwater	X	X	X	• No impact will be expected in this matter.	-	-	-
16. Hydrology	X	X	X	• No impact will be expected in this matter.	-	-	-
17. Coastal Area such as Mangrove, Coral Reef and Tidal Area	X	X	-/C	• Increase in chemical and fertilizer would affect water quality of Tonle Sap.	• In order to avoid excessive utilization of fertilizer and chemicals, some supporting programs are essential such as introduction of integrated pest management (IPM). <i>(FWUC Establishment and Strengthening)</i>	• Site reconnaissance • Water Quality Sampling and Analysis	• O&M Phase
18. Flora, Fauna and Biodiversity	X	-/C	-/C	• Existing Damnak Ampil gate would be affecting fish migration up and down since there is no fish ladder equipped.	• Although direct beneficiaries of the sub-project are farmers engaging in irrigated agriculture, construction schedule should be prepared considering fish spawning habitat as well as fishing season of fish farmers surrounding sub-project. • In addition, facilities design needs to consider fish habitat. In addition to gate rectification work, construction of fish ladder with intake weir is one of the effective mitigation measures to improve current situation. <i>(Construction of Fish Ladder)</i>	• Site Reconnaissance	• Construction and O&M Phase
19. Meteorology	X	X	X	• No impact will be expected.	-	-	-
20. Landscape	X	X	X	• No impact will be expected.	-	-	-
21. Global Warming	X	X	X	• No impact will be expected.	-	-	-
Pollution							
22. Air Pollution	X	-/C	X	• Not more than serious impact will be expected since structures under the plan are not large scale. But machinery use during the construction shall be considered.	• During earth works, it is effective to provide sprinkling to mitigate dust. In addition, reducing idling time of construction machinery is essential to minimize exhaust gas from construction machinery. <i>(Environmental Consideration in Technical Specification for Construction Works)</i>	• Training of operators for construction machinery	• Construction Phase
23. Water Pollution	X	-/C	-/C	<u>Construction</u> • Increase of waste water will possibly happen due to inflow of labor for construction. <u>O&M</u> • Inappropriate use of chemical and fertilizer, if farming improvement and extension is not properly carried out, would increase to affect water quality.	• Education programs should be carried out for construction labors to raise their awareness on proper disposal treatment. <i>(Education Program for Construction Labor)</i> • In addition, technical specification of the construction works should involve mitigation measures on environmental impact including construction waste disposal. <i>(Environmental Consideration in Technical Specification for Construction Works)</i>	• Water sampling • Quality analysis	• Design and Construction Phase
24. Soil Contamination	X	X	-/C	• Misuse and/or excessive use of fertilizer would contaminate soil in command area under irrigation system.	• In order to avoid excessive utilization of fertilizer and chemicals, some supporting programs are essential such as introduction of integrated pest management (IPM). <i>(FWUC Establishment and Strengthening)</i>	• Soil sampling and analysis	• O&M Phase
25. Waste	X	-/C	X	• Waste from construction would be expected.	• As well as mitigation of water pollution, education programs should be carried out for construction labors to raise their awareness on proper disposal treatment. In addition, technical specification of the construction works should involve mitigation measures on environmental impact including construction waste disposal. <i>(Education Program for Construction Labor)</i>	• Site Supervision	• Construction Phase
26. Noise and Vibration	X	-/C	X	• Noise and vibration through construction works would be expected.	• Working hour needs to be agreed through stakeholder meetings so as not to disturb living condition of communities. <i>(Environmental Consideration in Technical Specification for Construction Works) & (Education Program for Construction Labor)</i>	• Site Supervision	• Construction Phase
27. Ground Subsidence	X	X	X	• No impact will be expected since no large scale new facilities are included under the plan. In addition, scooping up of great amount of groundwater will not be carried out.	-	-	-
28. Offensive Odor	X	X	X	• No impact will be expected.	-	-	-
29. Sedimentation	X	X	X	• No impact will be expected.	-	-	-
30. Accidents	X	-/C	X	• This would be due to increase of vehicle and construction machinery during construction stage.	• This issue would be due to increase of vehicle and construction machinery during construction stage. <i>(Education Program for Construction Labor)</i>	• Site Supervision	• Construction Phase

Note

- : Adverse Impact
- X : No Impact
- + : Positive Impact
- A : Great Impact
- B : Medium Impact
- C : Small Impact

Figures

SOIL MAP OF PURSAT RIVER BASIN

Subsidiary Basin, Irrigation and Drainage Master Plan Study
 JICA Japan International Cooperation Agency (JICA)

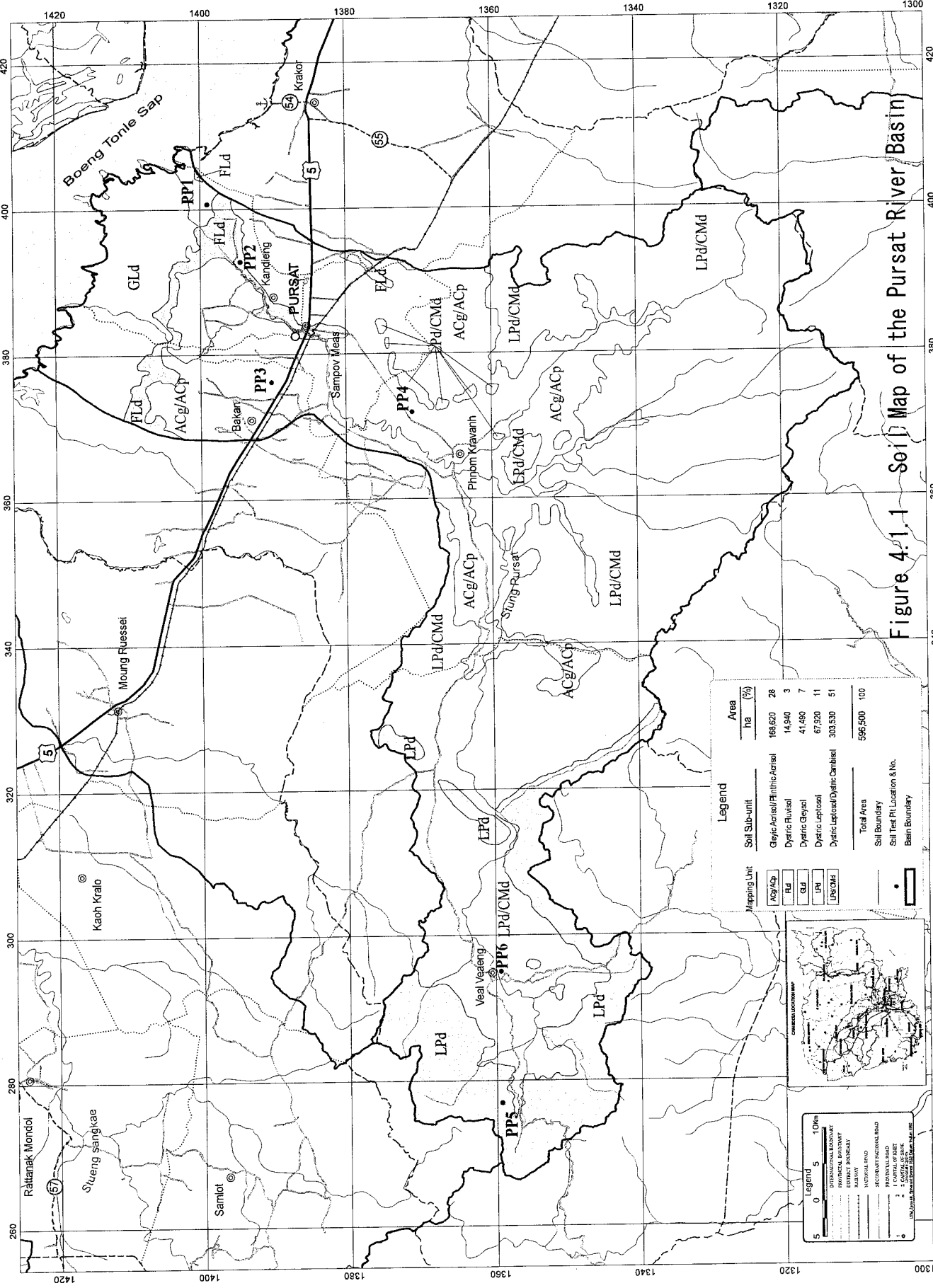

Mapping Unit	Soil Sub-unit	Area
		ha (%)
ACg/ACp	Cleyic Acrisols/Pitolic Acrisols	168,620 28
FLd	Dystric Fluvisols	14,940 3
GLd	Dystric Gleysols	41,480 7
LPr	Dystric Lixisols	67,920 11
LPr/CMd	Dystric Lixisols/Dystric Cambisols	303,530 51
Total Area		596,500 100

Legend
 Soil Boundary
 Soil Text Pt. Location & No.
 Basin Boundary

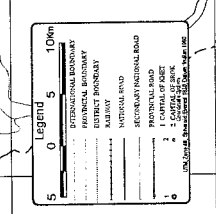
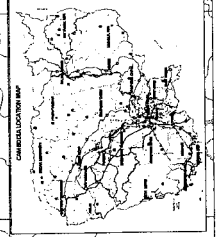
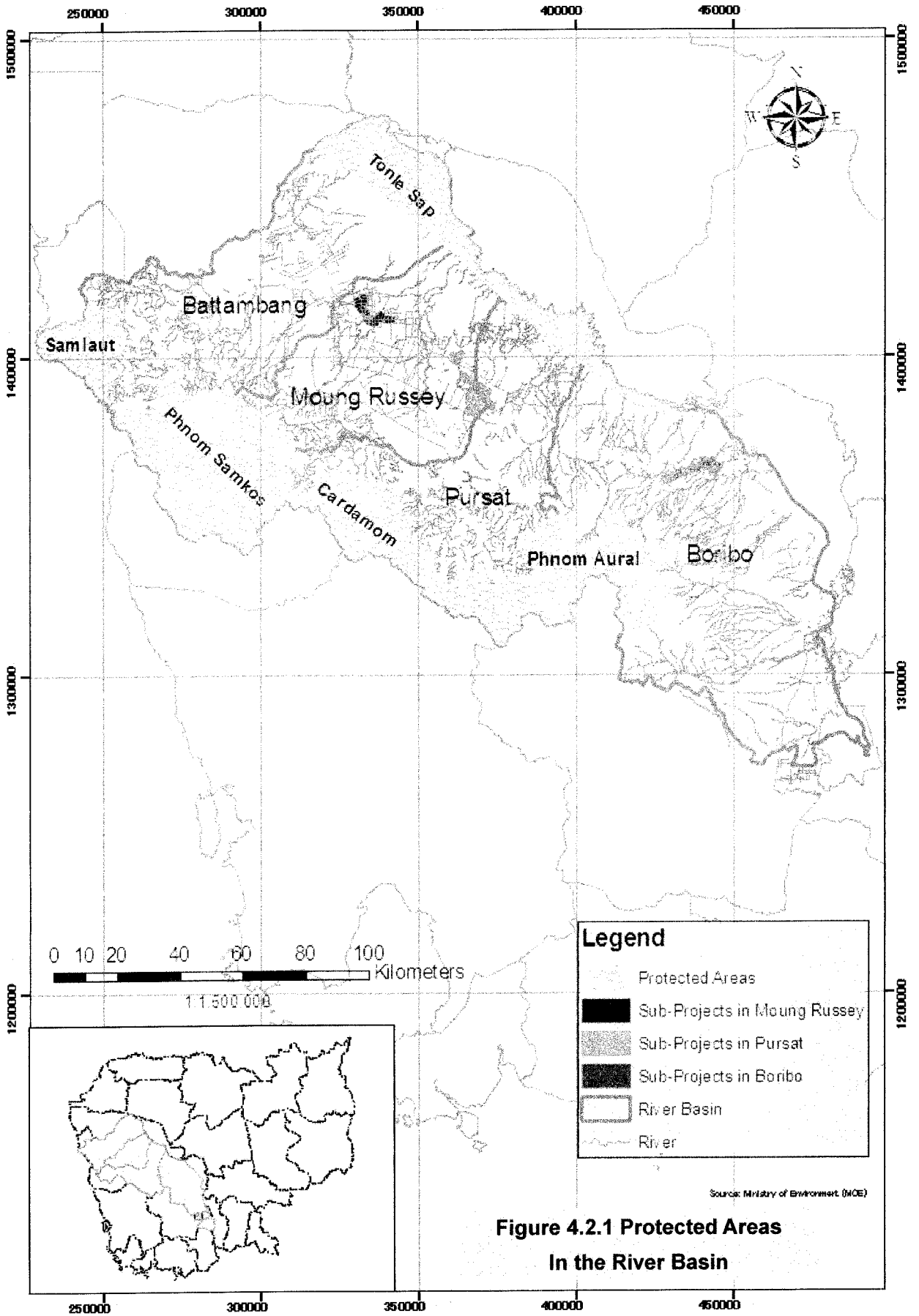

Figure 4.1-1 Soil Map of the Pursat River Basin

Source: Soil map prepared by the Tonle Sap Stabilization project, ADB, 2006



**Figure 4.2.1 Protected Areas
In the River Basin**

**List of institutions, its influence and physical distances, refer following
Table of Rolok Sar Commune Pursat Province of Domnak Ampel Irrigation (Group 1)**

Gov.	Institutional	Influence	Physical distances
		Large, moderate or small	Near, moderate or far
G-1	PDOWRAM	Big	Near
G-2	MOWRAM	Small	Far
G-3	District of Agriculture (DOA)	Big	Moderate
G-4	Provincial of Agriculture (PDOA)	Fair	Moderate
G-5	Provincial of Environment (PDOE)	Fair	Moderate
G-6	Ministry of Environment (MOE)	Small	Far
G-7	District of Land Management (DOLM)	Big	Near
G-8	Provincial of Land Management (PDOLM)	Fair	Far
G-9	District Authority	Big	Moderate
G-10	Provincial of Authority	Fair	Moderate
G-11	Provincial of Rural Development	Fair	Moderate
Private			
P-1	Middlemen	Big	Moderate
P-2	Panshop	Big	Near
P-3	Pursat Market	Fair	Far
Credit			
C-1	ACLIDA	Big	Moderate
C-2	CREDIT	Big	Moderate
C-3	PRASAC	Big	Moderate
C-4	HATHA KASEKO	Big	Moderate
C-5	SEILA FUND	Big	Moderate
C-6	SATHAPNA	Big	Moderate
NGO			
N-1	Pon Leu koma Organization	Big	Near
N-2	Concern abdo Organization	Big	Moderate
N-3	JICA	Big	Far

Institutions Linkage Map of Rolok Sar Commune Domnak ampel Irrigation (Group 1)

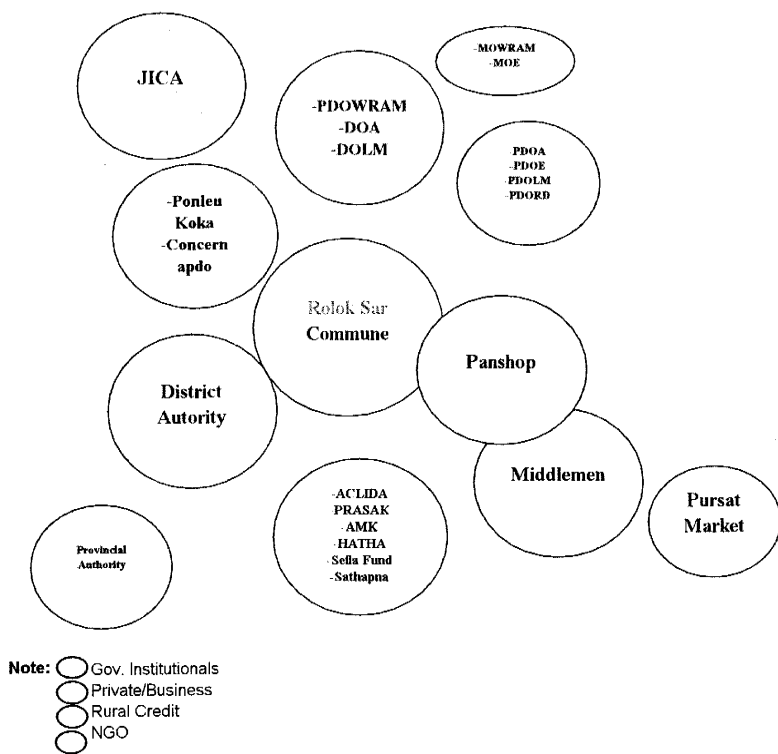

Figure 5.1.1 Institutional Linkage Map of Lolok Sar Commune

Flow Chart on Production Market Process of Rolok Sar Commune Domnak Ampel Irrigation (Group 1)

Gov.	Institutional	Influence	Physical distances	Characteristics and transaction
		Large, moderate or small	Near, moderate or far	
G-1	PDOWRAM	Big	Near	Provide tchnology,breed, plantation,rice cultivation, compost,crop,seed,serching market price for krama 8 places and wat loung and training children supported by NGO
G-2	MOWRAM	Small	Far	
G-3	District of Agriculture (DOA)	Big	Moderate	
G-4	Provincial of Agriculture (PDOA)	Fair	Moderate	
G-5	Provincial of Environment (PDOE)	Fair	Moderate	
G-6	Ministry of Environment (MOE)	Small	Far	
G-7	District of Land Management (DOLM)	Big	Near	
G-8	Provincial of Land Management (PDOLM)	Fair	Far	
G-9	District Authority	Big	Moderate	
G-10	Provincial of Authority	Fair	Moderate	
G-11	Provincial of Rural Development	Fair	Moderate	
Private				
P-1	Middlemen	Big	Moderate	Buy rice 600R-800R/kg ,chicken 10.000R-13.000R/kg , pig 9.000R-10.000R/kg vegetables 1.000R/kg,sell fertilizers 115.000R/50kg
P-2	Rice Mill	Big	Near	Price 800-850/kg they bring by thire won
P-3	Pursat Market	Fair	Far	Sell agriculture instruments, buy beverages, equipments take taxi about 30mn pay fee about 2000R-4000R
Credit				
C-1	ACLIDA	Big	Moderate	Borrowing and Lending Mortgage's rice-field Rate 2-3% per monthBorrower had fidelityHave an agreementEye witnessAuthorized by local authority
C-2	CREDIT	Big	Moderate	
C-3	PRASAC	Big	Moderate	
C-4	HATHA KASEKO	Big	Moderate	
C-5	SEILA FUND	Big	Moderate	
C-6	SATHAPNA	Big	Moderate	
NGO				
N-1	Pon Leu koma Organization	Big	Near	None
N-2	Concern abdo Organization	Big	Moderate	None
N-3	JICA	Big	Far	None

Flow Chart on Production Market Process of Rolok Sar Commune Domnak ampel Irrigation (Group1)

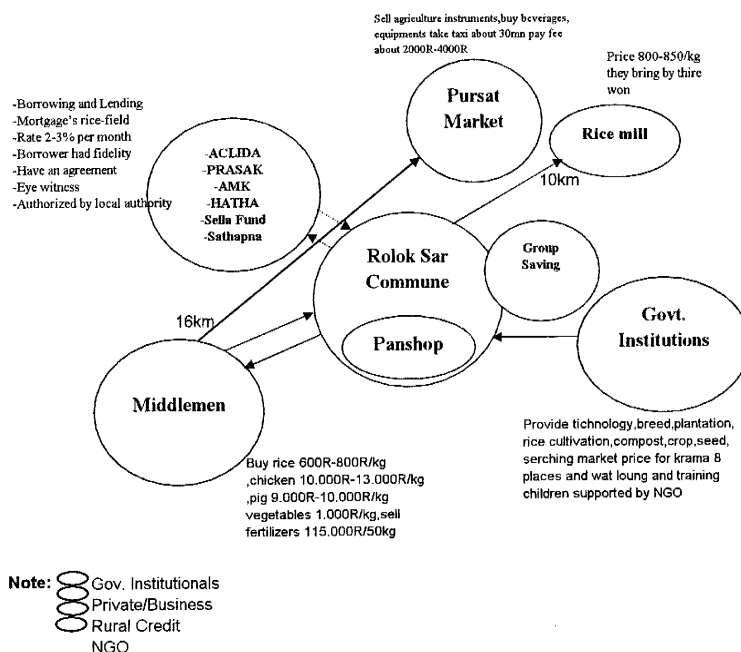

Figure 5.1.2 Production-Marketing Flow Process of Lolok Sar Commune

List of Institutions, its influence and physical distances, refer following Table of Snam Preh Commune Pursat Province of Damnak Ampil Irrigation (Group 3)

Gov.	Institutional	Influence		Physical distances	
		Large, moderate or small	Near, moderate or far	Near, moderate or far	Near, moderate or far
G-1	PDOWRAM	Big	Near		
G-2	Provincial of Rural Development	Fair	Far		
G-3	Provincial of Women Affaire	Fair	Moderate		
G-4	Provincial of Agriculture (PDOA)	Big	Moderate		
G-5	Ministry of Agriculture (MOA)	Big	Moderate		
G-6	Provincial of Education Youth & Sport	Big	Far		
G-7	Provincial of Environment (PMOE)	Big	Near		
G-8	Provincial of Health	Big	Moderate		
G-9	FWUC	Big	Near		
G-10	Community of maintance path	Big	Moderate		
G-11	Forestry Admin	Big	Far		
G-12	Health federal Center	Big	Near		
Private					
P-1	Middlemen	Fair	Near		
P-2	Snam Prah Market	Fair	Near		
P-3	Pursat Market		Moderate		
Credit					
C-1	AMK	Small	Moderate		
C-2	PRASAC	Small	Moderate		
C-3	HATHA KASEKO	Small	Moderate		
C-4	Seila nithuk	Fair	Moderate		
C-5	Racha	Small	Moderate		
NGO					
N-1	Abdo	Fair	Near		
N-2	Pon leu koma	Fair	Near		

Institutions Linkage Map of SNAM PRAH Commune Domnak ampel Irrigation (Group 3)

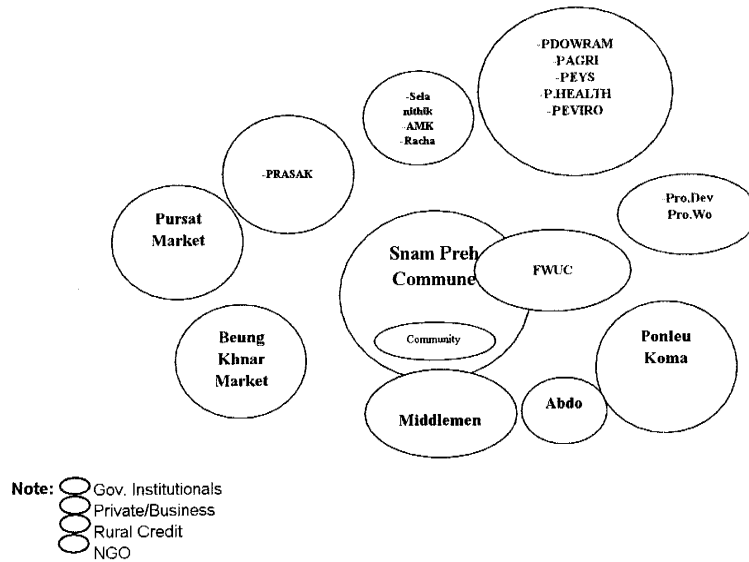

Figure 5.1.3 Institutional Linkage Map of Snam Preh Commune

Flow Chart on Production Market Process of Snam Preh Commune
Dannak Ampil Irrigation (Group 3)

Gov.	Institutional	Influence	Physical distances	Characteristics and transaction
		Large, moderate or small	Near, moderate or far	
G-1	Provincial of Rural Development	Fair	Moderate	Provide dam, canal technologies for cultivation and school, medicine, and 1 project from using chemical fertilizers
G-2	Provincial of Women Affaire	Fair	Moderate	
G-3	PDOWRAM	Big	Near	
G-4	Provincial of Agriculture (PDOA)	Big	Moderate	
G-5	Ministry of Agriculture (MOA)	Big	Moderate	
G-6	Provincial of Education Youth & Sport	Big	Far	
G-7	Provincial of Environment (PMOE)	Big	Near	
G-8	FWUC	Big	Near	To manage water management by village, commune, and to establish federation to maintain water regularity
G-9	Community of maintance path	Big	Moderate	Provide path and maintance path in the community
G-10	Forestry Admin	Big	Far	None
G-11	Provincial of Health	Big	Moderate	Provide medicines and take care of sick persons in community
G-12	Health federal Center	Big	Near	
Private				
P-1	Middlemen	Fair	Near	buy green bean 1.000R/kg, cucumber 800R/kg, rice 800R/kg, chicken 12.000R/kg, sugarcane 3000R/bunches, banana 1.000R/hands, orange 15.000R/forty, eggplant 1.500R/kg
P-2	Snam Prah Market	Fair	Near	Buy and sell all things move back and forth
P-3	Pursat Market		Moderate	buy construction materials, cloths, jewelry, bicycle, moto, waking tractor, pumping machine, fertilizer, deisel, and sell chickens, ducks, plgs, rice, vegetables gains 3% over middlemen.
Credit				
C-1	AMK	Small	Moderate	To lend, but farmer must have land certificate, house, farm land or rice field, charge 3% borrow less then 1.000\$, but have to authorized by chief of commune and references
C-2	PRASAC	Small	Moderate	
C-3	HATHA KASEKO	Small	Moderate	
C-4	Seila nithik	Fair	Moderate	
C-5	Racha	Small	Moderate	
NGO				
N-1	Abdo	Fair	Near	Provide wells, pound, path, breed, school, health care center+medicine
N-2	Pon leu koma	Fair	Near	Provide wells, pound, path, breed, school, health care center+medicine

Flow Chart on Production Market Process of Snam Preh Commune Dannak Ampil Irrigation (Group 3)

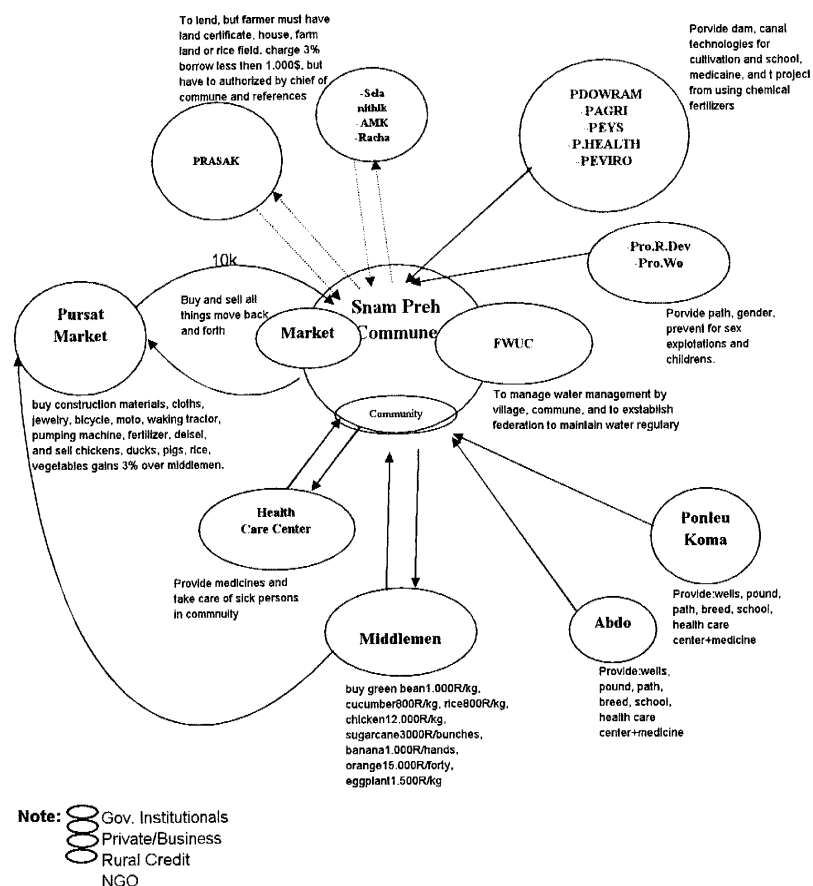

Figure 5.1.4 Production-Marketing Flow Process of Snam Preh Commune