

## 添付資料

- 添付資料-1 ワークショップ配布資料
  - 1.1 1st Workshop (January 2008)
  - 1.2 2nd Workshop (August 26, 2008)
  - 1.3 3rd Workshop (November 5, 2008)
- 添付資料-2 技術移転セミナー
- 添付資料-3 石炭輸送に関する検討概要
- 添付資料-4 Coal Supply to PLN
- 添付資料-5 Operation Record
  - 5.1 Operation Performance Record for the Existing Power Plants of PJB
  - 5.2 Operation Performance Record for the Existing Power Plants of Indonesia Power
- 添付資料-6 WASP IV シミュレーションデータ
  - 6.1 入力データ
  - 6.2 出力データ
- 添付資料-7 General Information of System Planning
- 添付資料-8 Outline of PSS/E Software
- 添付資料-9 Paiton Baru 発電所環境影響評価書
- 添付資料-10 Suralaya 発電所環境モニタリング報告書
- 添付資料-11 Rembang 発電所の環境影響評価に関する PLN 内部文書
- 添付資料-12 帰国報告書
  - 12.1 第一年次 業務完了報告書 (平成 20 年 2 月)
  - 12.2 第二次現地調査 帰国報告書 (平成 20 年 6 月)
  - 12.3 第三次現地調査 帰国報告書 (平成 20 年 9 月)
  - 12.4 第四次現地調査 帰国報告書 (平成 20 年 12 月)

## **添付資料－1 ワークショップ配布資料**

**1.1 1st Workshop (January 2008)**

**1.2 2nd Workshop (August 26, 2008)**

**1.3 3rd Workshop (November 5, 2008)**

## **1.1 1st Workshop (January 2008)**

# STUDY PLAN

**Study on  
Optimal Electric Power Development  
in Java-Madura-Bali  
in the Republic of Indonesia**

January 2008  
NEWJEC Inc.  
The Kansai Electric Power Co., Inc.

## Table of Contents

1. Current issues in Indonesia
2. Policy
3. Work Plan
4. Organization of the Team
5. Works

- ### 1. Current issues in Indonesia
- 1-1. Rising oil fuel prices
  - 1-2. Coal-Fired Crash Program
  - 1-3. Power Generation Facilities
  - 1-4. Java-Sumatra Interconnection

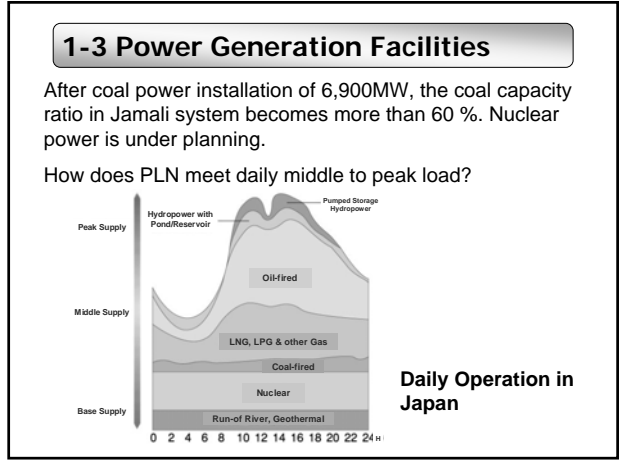
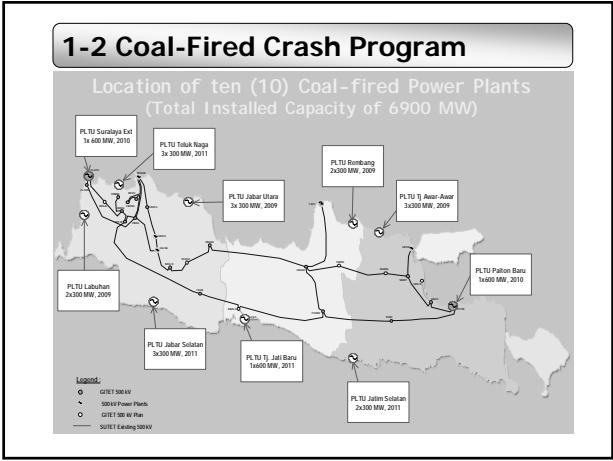
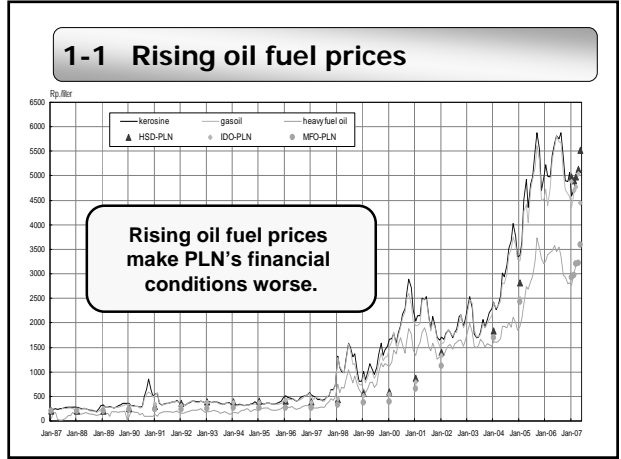

### 1-4 Java-Sumatra Interconnection

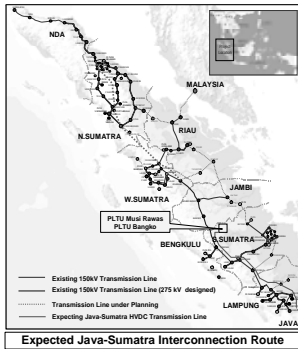

Coal power plants are going to be developed in South Sumatra by IPP and the surplus power is transmitted to Java through under-sea water DC line. The surplus power is expected at 1,200 MW in 2011/12 and 3,000 MW in 2014.

### 2. Policy

- i. To keep consistency with past studies.
- ii. To take into account the peak demand shift in the future.
- iii. To develop the integrated optimal power generation development (best mix) plan reviewing the role of existing power stations.
- iv. To develop the integrated optimal transmission system development plan in terms of economy and reliability.
- v. To propose improvement measures for Jamali system operation and maintenance based on the experience of the KANSAI.

### 3. Work Plan

Fiscal Year 2007			Fiscal Year 2008											
1	2	3	4	5	6	7	8	9	10	11	12			
1	2	3	4	5	6	7	8	9	10	11	12			
Preliminary Study Stage			Study Stage on Optimal Scenario			Conclusion and Recommendation Stage								
1st Field Work			2nd Field Work			3rd Field Work			4th Field Work					
Preparation Work			1st Home Work			2nd Home Work			3rd Home Work			4th Home Work		
▲ I/R			▲ I/R			▲ I/R			▲ D/R			▲ F/R		
▲ WS1 (JKT)						▲ WS2 (SBY) ▲ Seminar			▲ WS3 (JKT)					

### 4. Organization of the Team

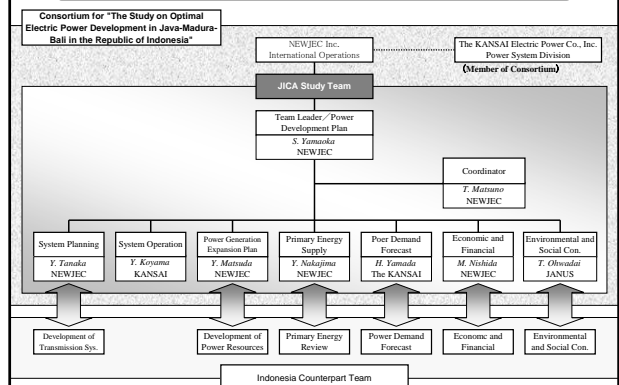

### 5. Works

- 5-1. Power Demand Forecast
- 5-2. Primary Energy Supply
- 5-3. Generation Expansion Plan
- 5-4. Power System Plan
- 5-5. Study on Recommendation for Improvement of Power System Operation
- 5-6. Economic and Financial Study
- 5-7. Environmental and Social Consideration
- 5-8. Power Development Plan
- 5-9. Conclusion

### 5-1. Power Demand Forecast

- ◆ Review of existing demand forecast
- ◆ Review of economic policy, forecast of economic growth rate and regional development plan
- ◆ Evaluation of the possibility of application of DSM
- ◆ Evaluation of the possibility of energy saving measures
- ◆ Update of demand forecast
- ◆ Information to be surveyed

◆ **Review of existing demand forecast**

- (1) Review the existing demand forecast :
  - RUPTL
  - RUKN
  - other documents
- (2) Review the outline of the software for demand forecast which is used in MEMR and PLN

◆ **Review of economic policy, forecast of economic growth rate and regional development plan**

- Review the economic situation in the area which will be considered for demand forecast;
- Population in Jamali area (number and growth)
  - GDP growth rate and energy consumption by sector
  - Regional development plan

◆ **Evaluation of the possibility of application of DSM**

- (1) Review the action plan for DSM which was studied in the past
- (2) Evaluate the possibility of application of DSM considering the situation in Japan
- (3) Present methods for DSM in Japan if necessary

◆ **Evaluation of the possibility of energy saving measures**

- (1) Evaluates the effects of possible measures for energy saving
  - Evaluation of possibility and calculation of effects of measures for energy saving in factories, commercial demands and households.
  - Calculation of the reduction of energy consumption by applying electrical appliances
  - Evaluation of other measures
- (2) In the study, JICA team will have a support from the team of "The Study on Energy Conservation Promotion in Indonesia"

◆ **Update of demand forecast**

In consideration of the review of existing documents and the study, the demand from 2009 to 2028 will be forecasted in following ways;

Micro forecast

Forecast entire demand by accumulation of demands in each area.

- (1) Extract parameters which affect regional demand forecast
- (2) Build a demand forecast model and assume a transition of parameters in the future
- (3) Forecast energy consumption by sector
- (4) Calculate energy consumption by region
- (5) Calculate generated energy by region
- (6) Calculate peak demand by region
- (7) Calculate entire peak demand

Macro forecast

Forecast a entire demand directly.

- (1) Extract parameters which affect entire demand forecast
- (2) Build a demand forecast model and assume a transition of parameters in the future
- (3) Forecast entire energy consumption
- (4) Calculate entire generated energy
- (5) Calculate entire peak demand

Consistency between the result of micro forecast and the one of macro forecast will be checked.

◆ **Information to be surveyed**

Organization to be visited	Information and documents to be surveyed
MEMR, DGEEU PLN, System Planning PLN, P3B	<ul style="list-style-type: none"> <li>• The latest demand forecast and grounds for it. (Peak demand, Energy consumption, Number of customers, load factor, losses, electrification rate, etc.)</li> <li>• Existing capacity and taking-over estimation of captive generators</li> <li>• PLN Statistics, PLN Annual Report</li> <li>• Regional supply and demand</li> <li>• Outline of "DKL" and "Simple-E"</li> </ul>

Other information such as economic index, social development plan and DSM will also be surveyed with other experts.

**5-2. Primary Energy Supply**

- Evaluation of the Possibility of Energy Saving Measures (JICA Study on "Energy Conservation and Efficiency Improvement" is on-going.)

Evaluation of Current Status → Possibility of Power Demand Saving

- Evaluation of Primary Energy Potential

Constrained Condition → Possibility of Each Generation Type Power Development

**Issue: Allocation of Oil, Gas and Coal**

Power Plants	Capacity MW	2006	2007	2008
<b>Gas Demand (mmscfd)</b>				
<b>Existing Power Plant</b>				
PLTGU Gresik	PLTGU: 3 x 523	280	280	280
	PLTU: 3 x 200			
	2 x 100			
PLTGU Grati	PLTGU: 1 x 460	110	110	110
	PLTG: 3 x 100			
<b>Sub Total</b>		390	390	390
<b>New Power Plant</b>				
IPP PLTGU Pasuruan		-	-	-
<b>Sub Total</b>		0	0	0
<b>Demand Total</b>		390	390	390
<b>Gas Supply (mmscfd)</b>				
KODECO		93	93	123
AMERADA HESS			100	100
SANTOS				40
KEI RANCAK + PAGERUNGA		30	10	
EMP T/S/B				130
Potential EMP				
<b>Supply Total</b>		123	203	393
<b>Demand and Supply Balance (Deficit)</b>		(267)	(187)	3

Who or Which Authority can determine the allocation of Oil, Gas and Coal to PLN

Source: "Ketersediaan Energi Primer dan Strategi Pemanfaatannya, Forum Energi Primer 2006"

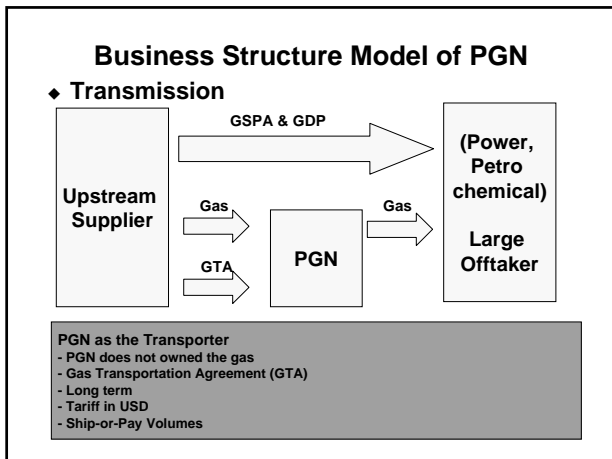

- ### Required Data/Information
- Development Plans for Oil, Gas and Coal including the Related Infrastructures
  - Allocation Mechanism of Oil, Gas and Coal to Power Sector (PLN)
  - Procurement Processes of Primary Energy
  - Development Plans of Gas Pipeline Network
  - Potential Reserve of Hydro and Geothermal

### 5-3. Generation Expansion Plan

#### Purposes

- Feasibility Assessment of the Existing Power Development Plans
- Accomplishment of Optimal Power Development Plan from 2009 to 2028

#### Key Issue: Finding Sites for the Future Power Plants Development

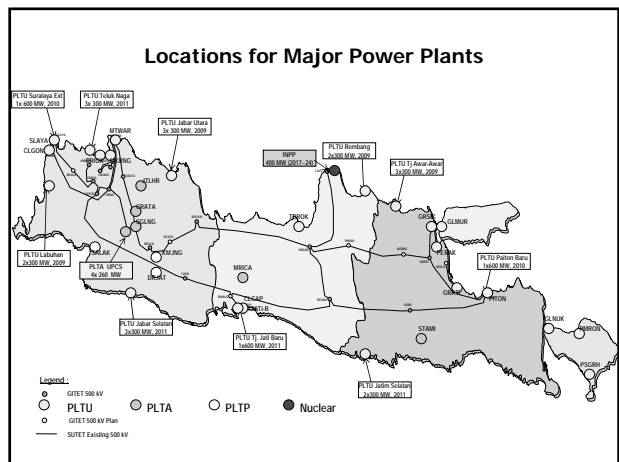

### Key Issue: Finding New Sites

		2007	2010	2015	2020	2025
Peak Demand	MW	16,511	20,247	27,846	37,634	50,454
Reserve Margin	%	35%	35%	35%	30%	30%
Required Capacity	MW	22,290	27,333	37,592	48,924	65,590
Existing Capacity	MW	18,760	19,256	13,152	9,887	7,909
Additional Capacity	MW	3,530	8,077	24,440	39,037	57,681
Crash Program	MW	0	6,900	6,900	6,900	6,900
Java-Sumatra Inter.	MW			3,000	3,000	3,000
Add. Capacity less Crash Program & Java-Sumatra	MW	3,530	1,177	14,540	29,137	47,781
<b>Additional Capacity per Year</b>	MW		1,177	2,673	2,919	3,729
Number of Equivalent Power Plants of 600 MW	Nos		2.0	4.5	4.9	6.2

Reference Data : RUKN 2006 , MEMR

**Alternative Measures against Finding New Sites**

(a) Repowering of the Existing Plants (b) Scrap and Build of the Existing Plants, and (c) Reinforcement of Java-Sumatra connection.

- ### Required Data/Information
- The Latest RUKN (2006. 06 ?) and RUPTL (2006.11?)
  - Current Progress Status of the Crash Program
  - Potential Candidate Sites (Map) for the Future Power Resources Development
  - Operation Performance Data of the Existing Major Power Plans for WASP IV

## 5-4. Power System Plan

### ◆ Data Collection

- Step 1 :
- Collection of Documents related to System study
  - Hearing of Power System Situation

Incorporation of Evaluation Result into Plan

- Main Site Visits & Related documents --
- Site Visit : PLN, P3BPLN, Resional Control Center(4 Sites)
- Related Documents :
- PLN Statistics 2006
  - Power System Development plan
  - Power system Grid Code Criteria
  - Data Required for System Analysis
  - Power development Method of P3B

### ◆ Keen Items

- Step 2 :
- Evaluation of Current Power Development Method

- Change of Power System Plan
  - Sumatera-Java Connection to Jamali System
  - Large Development Plan of Coal-Fired Power Plants

Development  
of  
"Optimum Power System Reinforcement Plan"

### ◆ Main Consideration

- Optimization of System Reinforcement coincide to Power Plants Development

- ★ Affection of Sumatera-Java connection to Jamali system
  - Review of Jakarta Vicinity power system including DC connection point
  - Evaluation of power system stability including DC connection accident
- ★ Power system planning considering following points
  - Incorporation of large development plan of Coal-fired power plants
  - Increase of Capacity of Unclear & Coal power plant to total Capacity
    - \*Base Load supply of Nuclear and large Coal power plants
    - \*Peak Load Supply of Gas turbine & Hydro power plants
- ★ Efficient operation of pumped storage power plant
- ★ Avoiding Expansion of System Accident

### ◆ System Analysis

- Development of the integrated optimal system Reinforcement plan with Criteria of Reliability

- ★ Optimal Plan should be developed up to 2028
  - Key Year of 2010, 2015, 2020 and 2028 should be analyzed
- ★ "PSS/E" soft wear should be used for Analysis
- ★ Reliability Criteria
  - Total power system should be stable in case of any Equipment or Route Down Accident

## INFORMATION REQUIRED (Purpose for System analysis)

- For carrying out the system analysis using PSSE, it would be appreciated if you could provide the following data.
  - Data in detail is listed in Questioner requested -

- ★ Information of Power system
  - The latest power developing program
  - Power system Diagram and power flow
  - Contingency Criteria( Single circuit outage etc)
- ★ Specification of Equipment
  - Power Plant : Capacity , G & Tr Impedance , Diagram of AVR & GOV etc,
  - Substation : Capacity , Tr Impedance etc,
  - Transmission Line : Capacity, Length, Impedance etc.

## Explanation of PSS/E

*PSS/E (Power system Simulation for Engineering) is the program, of which authorized distributor is SIEMENS/PTI, and widely used in many countries. PSS/E provides the following functions ;*

- ◆ Load flow analysis
- ◆ Short circuit current analysis
- ◆ Nominal state stability analysis
- ◆ Transient stability analysis
- ◆ Voltage stability analysis





## 5-5. Study on Recommendation for Improvement of Power System Operation

About KANSAI Electric Power Co., Inc.

### Japanese Electric Power Supply System

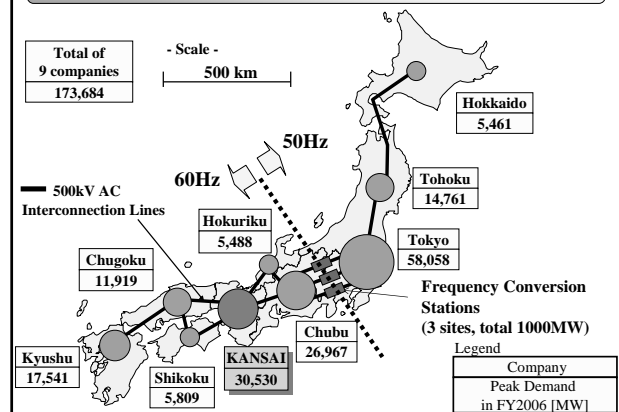

### KANSAI's Electricity Supply Area

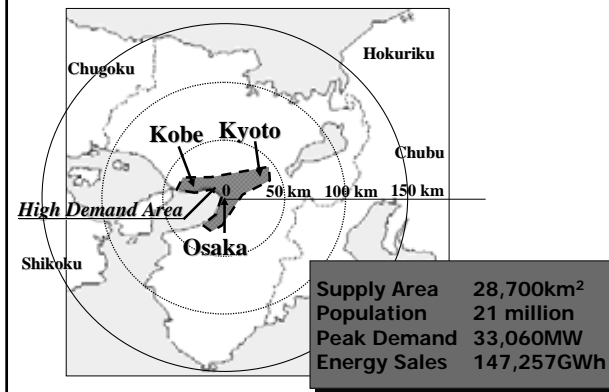

### KANSAI's Power System

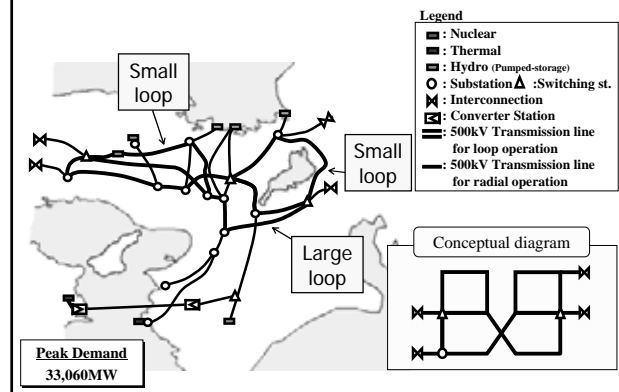

### Comparison of Basic Information in Power Systems

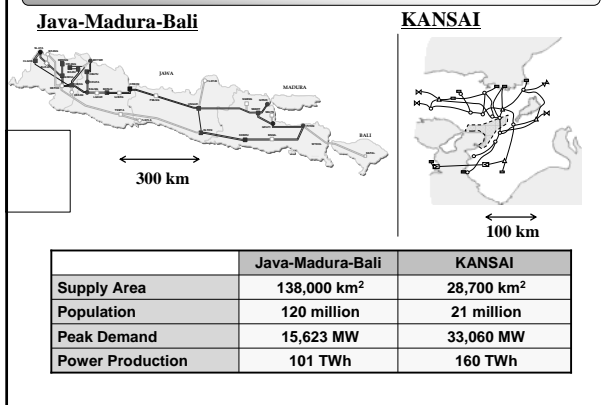

### Transition of Reliability in KANSAI

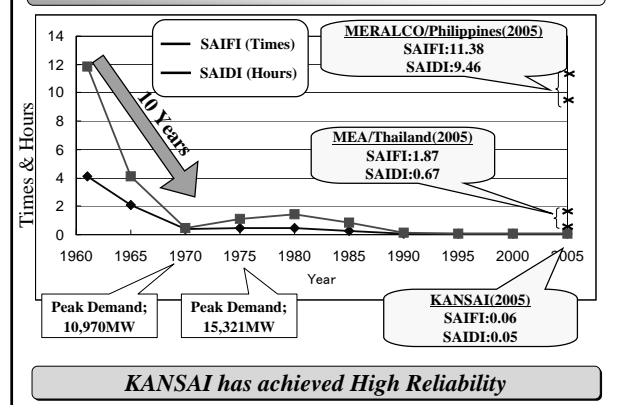

◆ Transition of Loss in KANSAI

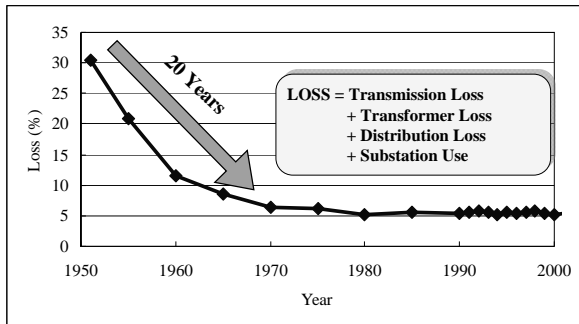

*KANSAI has achieved Small Loss System*

◆ Summary so far;

- Jamali System has enough potential to grow in the future.
- To improve quality of power system, long time and much cost are required.  
**NO MAGIC/SPECIAL WAY**

**You could find an effective way to improve your system from our experience on system operation.**

About Study on System Operation

◆ Schedule for Study on System Operation

Period	2008											
	1	2	3	4	5	6	7	8	9	10	11	12
Study stage	Preliminary Study Stage		Study Stage on Optimal Scenario			Conclusion and Recommendation Stage						
Report	Ic/R						Iu/R			Df/R		F/R
Workshop	1st WS						2nd WS Seminar			3rd WS		
System Operation	1st Field Work			2nd Field Work			3rd Field Work			4th Field Work		
	Visit Pusat, P3B & 4 RCCs to collect data & information						Discuss proposals to improve quality of system					

◆ Survey in the first field work

Organization to be visited	Information and documents to be surveyed
PLN Pusat, P3B, RCC	<ul style="list-style-type: none"> <li>• Framework of system operation</li> <li>• Framework of training and education</li> <li>• Rules for system operation</li> <li>• Method of system analysis</li> <li>• Record on power quality</li> <li>• PLN Statistics</li> <li>• System Operation Plan ,Evaluasi Operasi</li> <li>• Report of individual outage in the past</li> <li>• System diagram and power flow of Jamari system</li> <li>• Rules and manuals for system operation</li> <li>• Documents for training on system operation</li> </ul>

◆ Methodology for Study on Improvement of System Operation

[Flowchart of study]

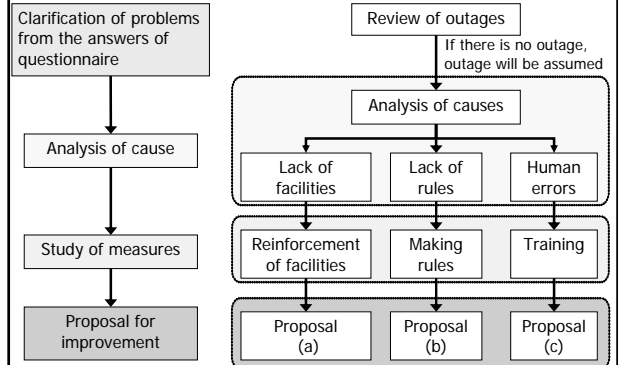

**◆ Possible Countermeasures to Improve System Operation**

possible countermeasures at this moment;

- (a) Reinforcement of facilities  
Reinforcement of facilities such as FACTS device and/or protection relay
- (b) Establishment of rules  
Establishment of rules such as system isolation and/or recovery from outage
- (c) Training  
Training of simulated outage and/or utilization of software for training

**JICA study team will propose countermeasures and discuss them with CP in the second field survey**

**5-6. Economic and Financial Study**

**Tasks**

- A. To find basic Regional Economic and Demographic Conditions for Demand Forecast
- B. To assess Investment Options and Financial Requirements for Optimal Power Development Plan

**◆ Task A : to find basic regional conditions**

**“HAVE BEEN’s” and “WILL BE’s”**

- Economy
  - production (RGDP) by [province x sector]
  - # of business establishments by [province x sector]
- Large Scale Development Plan  
e.g. heavy industry development, commercial complex development, tourism promotion (in Bali), etc
- Demography
  - population, # of households by province

**◆ Task B : to assess Investment Schedule**

- Investment Options
  - policy & prospect of IPP/PPA, joint venture
  - promotion strategy for IPP, joint venture
- Financial Requirements
  - with IPP promotion plan
- Investment Schedule
  - investment schedule for Optimal Power Development Plan

**◆ Information Requested and Schedule**

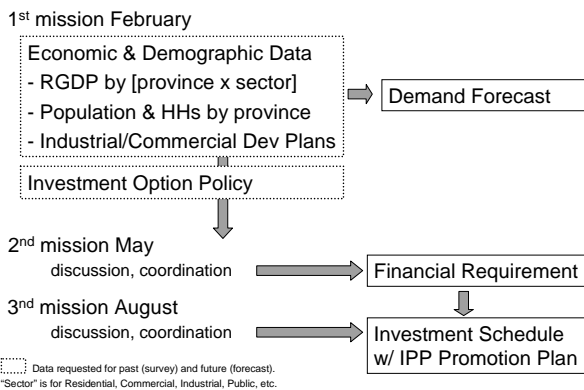

**5-7. Environmental & Social Consideration**

**Objectives**

**Incorporate Environmental & Social Considerations into the Study on Optimal Electric Power Development in Java-Madura-Bali Area through Strategic Environmental Assessment**  
(= Optimal Electric Power Development Scenario should not be identified solely for economic & engineering reasons)

◆ **What is Strategic Environmental Assessment (SEA)?**

Strategic Environmental Assessment (SEA)	Environmental Impact Assessment (EIA)
Applied to Policy, Plans & Programs (Upstream of Decision-Making)	Applied to Individual Projects (Downstream of Decision-Making)
General Assessment	Specific Assessment
Area Basis and/or Long-Term	Site and Project Specific
Can Consider Synergistic Impacts	Difficult to Consider Synergistic Impacts
Can Consider Cumulative Impacts	Difficult to Consider Cumulative Impacts
Greater Flexibility for Alternatives	Constrained to Specific Projects

◆ **What to do in SEA?**

- Identify Potential Environmental Impacts associated with each Type of Electric Power Generation
  - ex. SO<sub>2</sub>+NO<sub>x</sub>+CO<sub>2</sub> from Coal-Fired, Loss of Habitats/Involuntary Resettlement for Hydro, Radiation from Nuclear, H<sub>2</sub>S from Geothermal
- Identify Possible Measures to Prevent/Reduce/Mitigate Potential Environmental Impacts
  - ex. DeSO<sub>x</sub> & DeNO<sub>x</sub> for Coal-Fired, Improved Thermal Efficiency, Nuclear P/S in Unpopulated Area

*(If locations of individual P/Ss are identified in details to allow site assessment)*
- Siting of Individual P/Ss can be Assessed against Environmental Constraints at each Location.
  - ex. Proximity to Nature Conservation Area, Occurrence of Endangered/Precious Species, Closeness to Population Center, Agreement with Land-Use Plan

◆ **SEA for "Coal-Thermal Development Acceleration Program" on Air Quality**

**[Data Requirements]**

1. Total Emissions from 10 Coal-Fired P/Ss for SO<sub>2</sub>, NO<sub>x</sub>, SPM and CO<sub>2</sub> (without DeSO<sub>x</sub>, DeNO<sub>x</sub>, ESP)
2. Total Emissions from 10 Coal-Fired P/Ss for SO<sub>2</sub>, NO<sub>x</sub>, SPM and CO<sub>2</sub> (with DeSO<sub>x</sub>, DeNO<sub>x</sub>, ESP)
3. Total Emissions from All Existing P/Ss in Java for SO<sub>2</sub>, NO<sub>x</sub>, SPM and CO<sub>2</sub>

◆ **What is Output of SEA?**

- Provide Input to Identification of Alternative Electricity Development Scenarios
- Recommend Possible Environmental Protection Measures to the Optimal Electric Power Development Scenario

**5-8. Power Development Plan**

- Review and evaluation of national policies, relevant laws and regulation, and institutional framework on electric power sector
- Review and evaluation of institutional framework for power utility industry consisting of PT. PLN, Indonesia
- Setting up alternative scenarios for power development and identification of optimal scenario
- Finalization of optimal Jamali power development plan

◆ **Information Requested**

- National policies, relevant laws and regulation and institutional framework for electric power sector.
- Institutional framework on power utility industry in Jamali including PT. PLN.

## 5-9. Conclusion

- Accomplish the optimal power development plan, from 2009 to 2028, with the least cost under the conditions of probable power sources, probable site locations and environmental impact.
- Accomplish Jamali transmission system development plan corresponding to the optimal power development plan in terms of economy and reliability.
- Suggest the improvement methods of system operation through seminar based on the experience of the KANSAI and current conditions in Indonesia.
- Support to produce environment-friendly optimal power development plan

## **1.2 2nd Workshop (August 26, 2008)**

2ND WORKSHOP  
OF  
THE STUDY ON  
OPTIMAL ELECTRIC POWER DEVELOPMENT  
IN JAVA-MADURA-BALI  
IN THE REPUBLIC OF INDONESIA

AUGUST 26, 2008

AT

PJB HEAD OFFICE

PRESENTED BY

JICA STUDY TEAM

# THE STUDY ON OPTIMAL ELECTRIC POWER DEVELOPMENT IN JAVA-MADURA-BALI IN THE REPUBLIC OF INDONESIA

## Introduction

In response to the request of the Government of the Republic of Indonesia, the Government of Japan decided to conduct THE STUDY ON OPTIMAL ELECTRIC POWER DEVELOPMENT IN JAVA-MADURA-BALI IN THE REPUBLIC OF INDONESIA.

Accordingly, the Japan International Cooperation Agency (JICA), the official agency responsible for the implementation of the technical cooperation programs of the Government of Japan, will undertake the Study in close cooperation with the authorities concerned with the Government of Indonesia.

NEWJEC Inc. and the KANSAI Electric Power Co., Inc. have been selected as the JICA Study Team to conduct the captioned Study.

The Study will begin in January 2008 and finish in December 2008.

## Study Items

1. Power Demand Forecast
2. Primary Energy Supply
3. Generation Expansion Plan
4. Power System Plan
5. Study on Recommendation for Improvement of Power System Operation
6. Economic and Financial Study
7. Environmental and Social Consideration
8. Power Development Plan

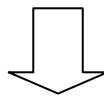











## Conclusion

1. Accomplish the optimal power development plan, from 2009 to 2028, with the least cost under the conditions of probable power sources, probable site locations and environmental impact.
2. Accomplish Jamali transmission system development plan corresponding to the optimal power development plan in terms of economy and reliability.
3. Suggest the improvement methods of system operation through seminar based on the experience of the KANSAI and current conditions in Indonesia.
4. Support to produce environmental friendly optimal power development plan.





## Member List of JICA Study Team

	Team Leader/ Power Development Plan		System Planning
	<b>Satoshi YAMAOKA</b>		<b>Yukao TANAKA</b>
	Group Manager Engineering Group International Operations NEWJEC Inc.		Vice General Manager International Operations NEWJEC Inc.
	System Operation		Generation Expansion Plan
	<b>Yasushi KOYAMA</b>		<b>Yasuharu MATSUDA</b>
	Manager System Planning Group Power System Division The Kansai Electric Power Co., Inc.		Group Manager International Project Group International Operations NEWJEC Inc.
	Primary Energy Supply		Power Demand Forecast
	<b>Yasufumi NAKAJIMA</b>		<b>Hiroaki YAMADA</b>
	Advisor Engineering Group International Operations NEWJEC Inc.		Engineer System Planning Group Power System Division The Kansai Electric Power Co., Inc.
	Economic and Financial Analysis		Environmental and Social Considerations
	<b>Masaru NISHIDA</b>		<b>Takashi OHWADA</b>
	Manager Tokyo-International Team Engineering Group International Operations NEWJEC Inc.		Consultant Environmental Consulting Group JAPAN NUS Co., Ltd.
	Transmission Engineer		Substation Engineer
	<b>Yoshio MARUOKA</b>		<b>Kazuhiro MANABE</b>
	Engineer Transmission Group Power System Technical Center The Kansai Electric Power Co., Inc.		Engineer Electricity Group Power System Technical Center The Kansai Electric Power Co., Inc.
	Coordinator		
	<b>Toshihiro MATSUNO</b>		
	Leader, Plant Team Engineering Group International Operations NEWJEC Inc.		

## The Study on Optimal Electric Power Development in Java-Madura-Bali in the Republic of Indonesia

### The 2nd Workshop Program

Date : 26 August 2008 at 10:00 AM.

Place: PJB Head Office

Subject: Interim Report

Time	Content	Presenter
10:00 - 10:10	Opening Speech by MEMR	
10:10 - 10:20	Opening Speech by JICA	
10:20 - 10:25	Opening Speech by PLN	
10:25 - 10:35	General	Mr.Yamaoka
10:35 - 10:50	Power Demand Forecast	Mr.Yamada
10:50 - 11:10	Primary Energy	Mr.Nakajima
11:10 - 11:40	Generation Expansion Plan	Mr.Matsuda
11:40 - 12:00	Question and Answer for the morning session	
12:00 - 13:00	Lunch Time	
13:00 - 13:30	Power System Operation	Mr.Koyama
13:30 - 14:00	Power System Plan	Mr.Tanaka
14:00 - 14:20	Economic and Financial Study	Mr.Nishida
14:20 - 14:50	Strategic Environmental Assessment	Mr.Ohwada
14:50 - 15:00	Coffee Break	
15:00 - 15:30	Power Development Scenario	Mr.Yamaoka
15:30 - 16:00	Question and Answer	
16:00 - 16:05	Closing Speech by PLN	

## 1. POWER DEMAND FORECAST

SPEAKER: MR. YAMADA HIROAKI,  
KANSAI ELECTRIC POWER CO., Inc.

# 1. Demand Forecast

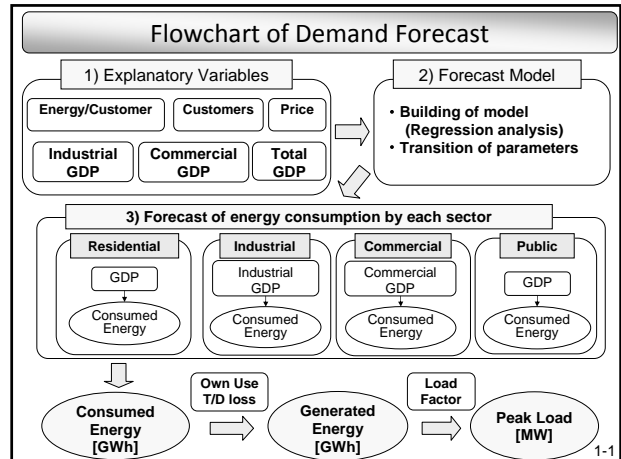
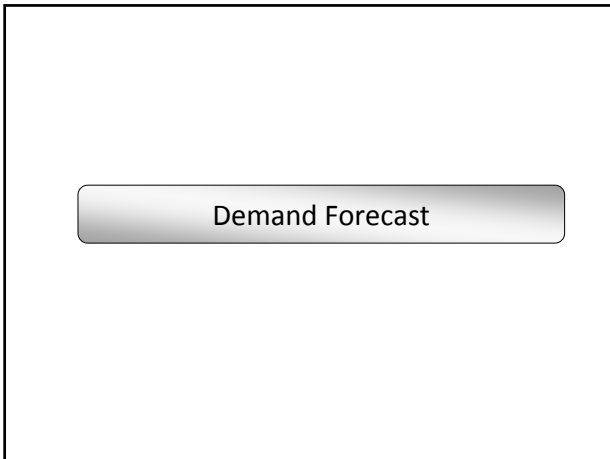

### Demand Forecast Scenarios

<Base Case> Will be used for generation development and system planning.

Index	Assumed Value	Ground
GDP growth	6.0 %/year	Past record and Related parties
Load Factor	Change every year	Load Curve Assumption
Loss Ratio (T&D)	Decrease slightly	Historical trend and Related parties

<High Case>

- Higher GDP growth than Base case (6.5%)
- Regression analysis including data before economic crisis
- Potential Demand (Constrained demand due to lack of supply)

<Low Case>

- GDP growth as same as Base Case (6.0%)
- Effect of energy saving studied by other JICA team (About 30% Reduction of Energy Consumption)

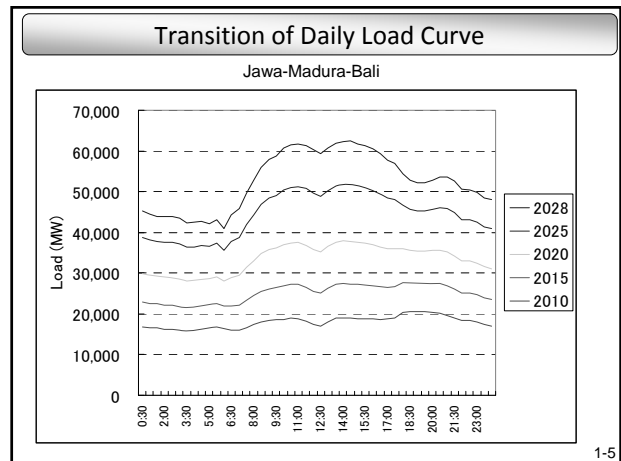
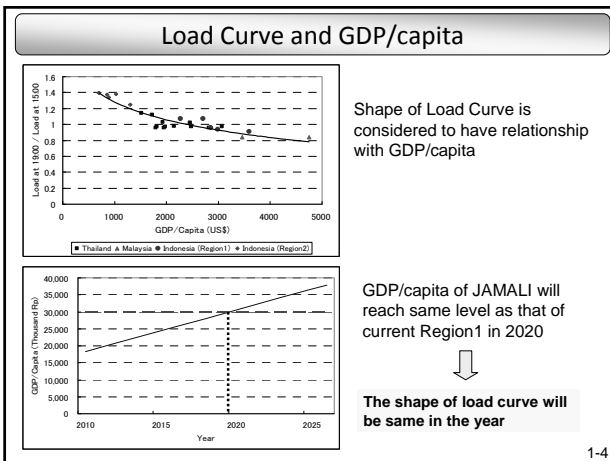
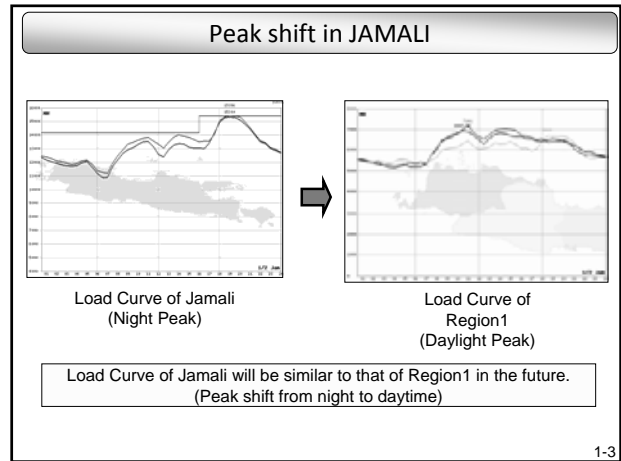

# 1. Demand Forecast

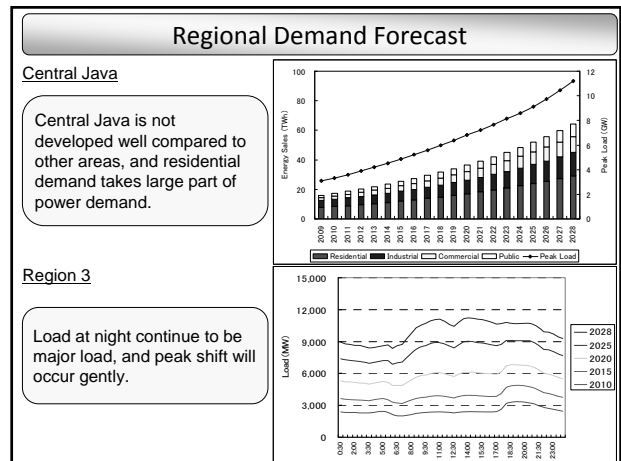
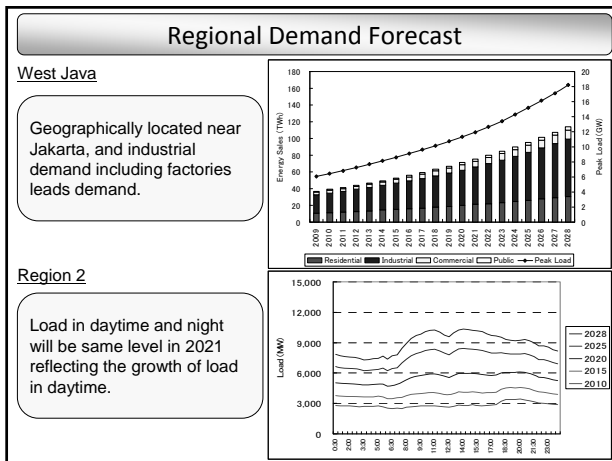
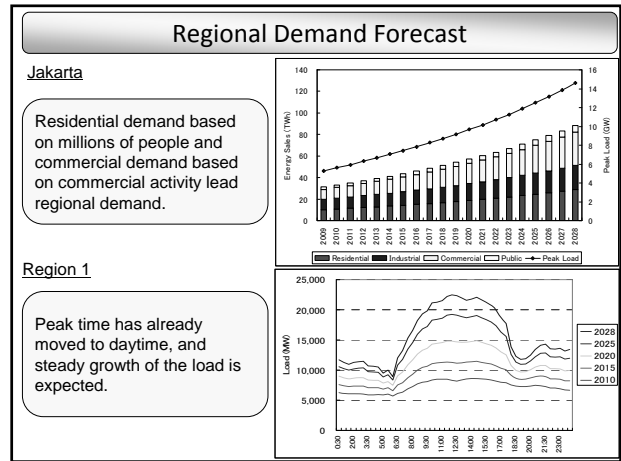
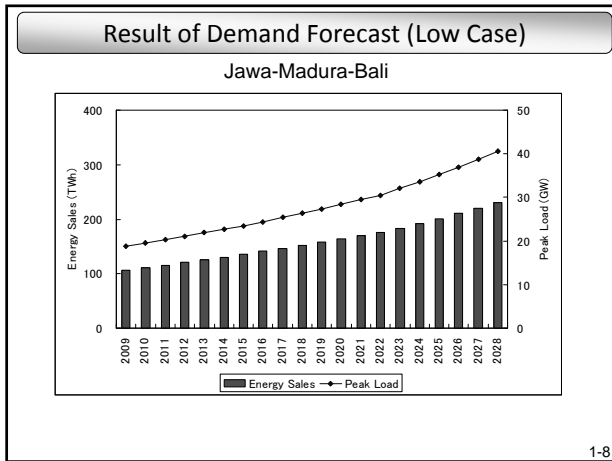
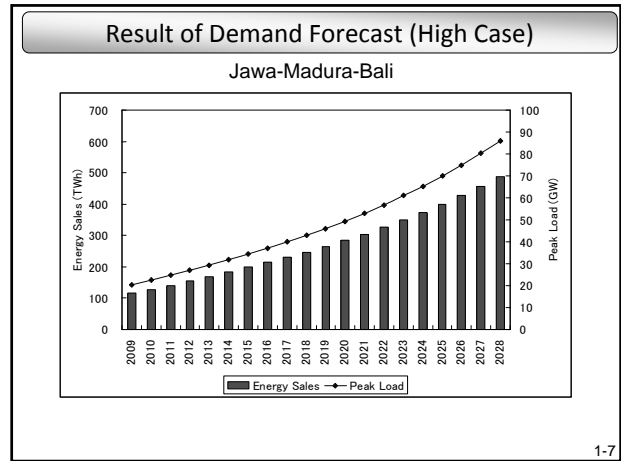
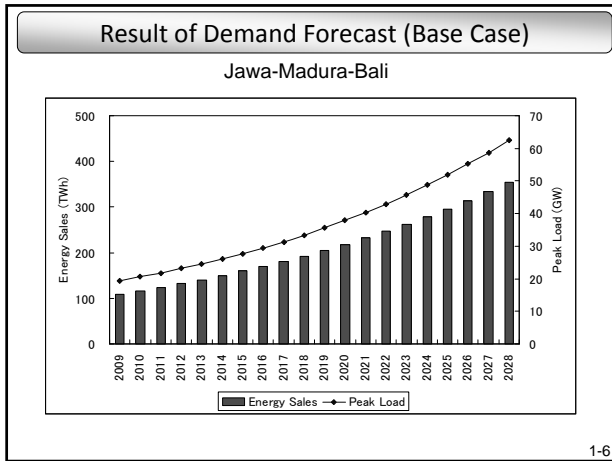

# 1. Demand Forecast

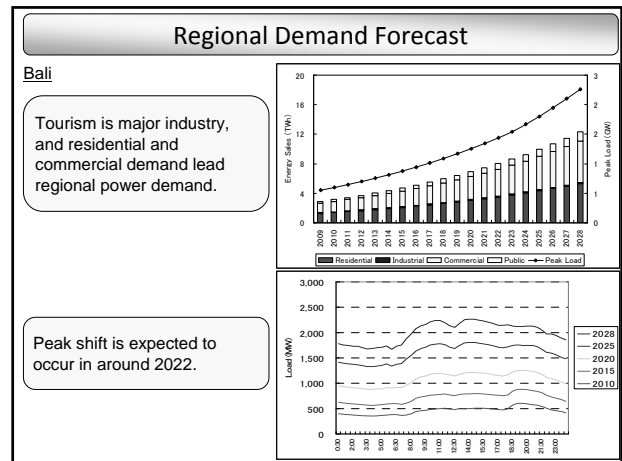
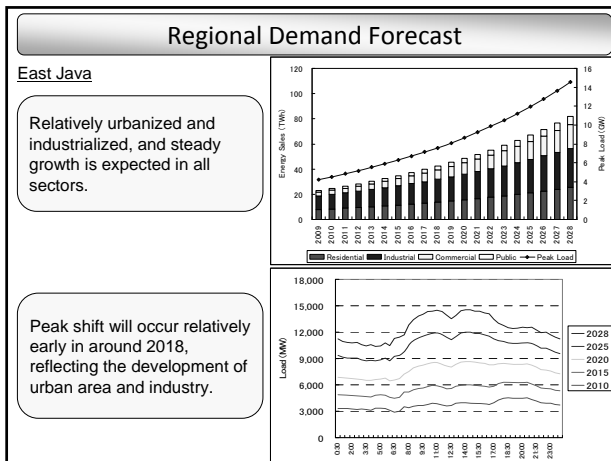

## 2. Primary Energy

SPEAKER: MR. NAKAJIMA YASUFUMI,  
NEWJEC Inc.



## 2. Primary Energy

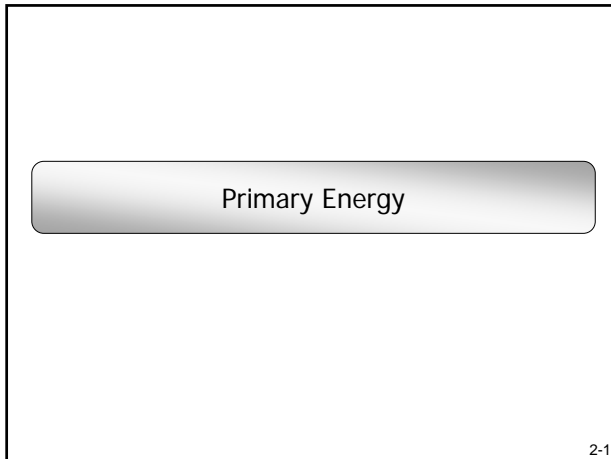

2-1

### 1. "Energy Mix" & Targets Toward 2025

- **Presidential Degree on National Energy Policy** (Jan. '06)
- **Reduce oil share from 55% (2005) to below than 20% in 2025**
- **Up to 2025, the use of :**
  - **Coal** from 15.7% to more than **33%**
  - **Natural gas** from 23% to more than **30%**
  - **Geothermal** from 1.9% to more than **5%**
  - **Bio-fuel** to more than **5%**
  - **Other New and Renewable Energy** from 0.5% to more than **5%**
- **Reduce energy consumption intensity by 1% annually**
- **Improve energy infrastructures condition**

2-2

### 2. Role of Power Plant

Type of PP	Fuel	Operation Mode	Remarks
1. PLTU	Coal	B → B or M	Major power generation
	Gas	B → M & partial P	
	Oil	B, M → X	
2. PLTG	Gas	B or M → B or M & partial P	Convert to PLGTU
	HSD	P	Convert to PLGTU with gas-fired or retire
3. PLTGU	Gas	B → B or M & partial P	Apply LNG or CNG
	HSD	B or P → P	Convert to Gas-fired or retire
4. PLTD	HSD	P or M → P or M	Only in remote area
5. PLTA	Large	M or P → M & partial P or P	Major peak generation
	Small	B → B	
	Pumped	P	
6. PLTP	-	B	Environmentally developed
7. PLTN	-	B	Environmentally developed

Operation Mode ( B ; Base Load M ; Middle Load P ; Peak Load )

2-3

### 3. Resources & Reserves of Coal in Indonesia

Coal Rank	HHV ( kca/kg ) Air Dried Base	Resources		Reserves	
		Billion Ton	%	Billion Ton	%
Low	<5100	14.95	24.4	2.98	44.1
Medium	5100-6100	37.65	61.5	2.44	36.1
High	6100-7100	7.97	13	1.22	18
Very High	>7100	0.67	1.1	0.12	1.8
<b>Total</b>		<b>61.24</b>	<b>100</b>	<b>6.76</b>	<b>100</b>

Coal required for 10,000MW PLTU = 30 Mill.Ton/Year

Low Rank Coal Demand for Power Generation

year	2010	2015	2025
Coal Demand (Mill.ton/y)	53	90	200

2-4

### 4. Coal for PLTU

- **Adoption of Low Rank Coal** for PLTU is the policy of Indonesian Government
- ✓ **Coal Characteristics**
- ✓ **Competitiveness in Domestic Market**
- **Stable Supply of Coal** is the key for stable operations of coal fired PLTU
- ✓ **Production Capacity**
- ✓ **Infrastructures** such as transportation, coal handling, coal storage, etc.

2-5

### 4.1 Typical Analysis of Low Rank Coal

Description	Typical	Rejection
Gross Caloric Value Kcal/kg (AR <sup>1</sup> )	4200	<4000 or >4500
Hardgrove Grindability Index	60	<45 or >65
Total Moisture % (AR)	30	>35
Ash Content % (AR)	5	>6
Sodium Content % (AR)	1.5	>4
Sulphur Content % (AR)	0.33	>0.35
Nitrogen % (AR)	Max. 1.2	>1.2
Slagging Fouling Index	Medium	>Medium
Grain Size through sieve 2.38mm	Max. 20%	>20%
Grain Size through sieve 2.38mm	Max. 80%	>80%
Grain Size through sieve 32mm	Min. 95%	<95%
Grain Size through sieve 2.38mm	100%	<98% (Max. size 10mm)
Ash Fusion Temperature (IDT) °C	1150	<1100

Note: AR=As Received Base

2-6



## 2. Primary Energy

### 5.3 CNG Storage System for Pipeline Gas

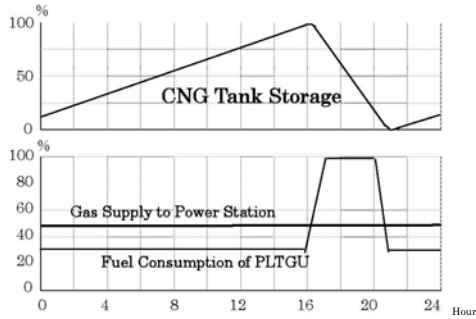

2-13

### 6. More Power and Efficiency Improvement Repowering (PLTG → PLTGU)

- \* Capacity increase; 50%
- \* Efficiency; 27% → 41%
- \* No Additional Fuel

Unit	Available Capacity
GT-1	134 MW
Efficiency	27%

Unit	Available Capacity
GT-1	134 MW
ST-1	66 MW
SUM	200 MW
Efficiency	41%

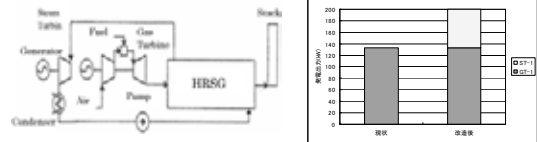

2-14

### 7. Resources of Geothermal

Region	Installed Capacity	Existing Plan	Possible New/Addition I	Total Resource Potential
Sumatra	2	913	3,605	4,520
Java-Bali	835	785	2,015	3,635
Nusa Tenggara	0	9	138	146
Sulawesi	20	140	575	735
Maluku	0	0	40	40
Tootal(MW)	857	1,847	6,373	9,076

Source: JICA; M.P. Study for Geothermal Power Development 2007

2-15

### 8. Potential of Renewable Energy

Non-Fossil Energy	potential	Installed Capacity
Hydro	75,670 MW	4,200 MW
Mini/Micro Hydro	459MW	84 MW
Solar	4.8kWh/m2/day (1203 TW)	8 MW
Wind	3 - 6m/s (9,290 MW)	0.5 MW

2-16

### 3. GENERATION EXPANSION PLAN

SPEAKER: MR. MATSUDA YASUHARU,  
NEWJEC Inc.

### 3. Generation Expansion Plan

## Generation Expansion Plan

## Table of Contents

- 1. Power Business in Jamali**
  - 1.1 Existing Power Generation Facilities
  - 1.2 Existing Power Generation Expansion Plan
  - 1.3 (Power Tariff and) Fuel Prices
- 2. Generation Expansion Plan**
  - 2.1 Candidates for Generation Expansion Plan
  - 2.2 Generation Expansion Model (Draft)

3-2

### 1.1 Existing Power Generation Facilities (1) Installed Capacity

Year	Installed Capacity		Rated Capacity		Total for Jamali	
	PLN	Out of PLN	PLN	Out of PLN	Installed Capacity	Rated Capacity
	MW	MW	MW	MW	MW	MW
Year 2005	16,356	N.A	14,225	N.A	N.A	N.A
Year 2006	18,416	3,895	16,990	3,837	22,311	20,827
**Year 2007	18,416	4,005	16,362	3,947	22,421	20,309

Source: PLN Statistical 2005 & 2006

3-3

### 1.1 Existing Power Generation Facilities (2) Installed Capacity & Generation Energy

Year	Installed Capacity (MW)						PLN Total Installed Capacity MW
	Steam	Gas Turbine	Combined C.	Geothermal	Diesel	Hydro	
	PLTU	PLTG	PLTGU	PLTP	PLTD	PLTA	
Year 2005	6,000	2,065.0	5,403	375	103	2,409	16,355
Year 2006	7,320	2,065.0	6,143	375	103	2,409	18,415

Year	Energy Production by Type of Fuel						PLN Total Production GWh
	HSD	MFO	Coal	Natural Gas	Geothermal	Hydro	
	GWh	GWh	GWh	GWh	GWh	GWh	
Year 2005	18,880	7,133.0	29,439	12,902	2,870	6,247	77,471
Year 2006	16,575	7,717.0	34,526	13,434	2,975	4,682	79,909

3-4

### 1.1 Existing Power Generation Facilities (3) Capacity and Generation Share

Year	Capacity Share by Type of Fuel (%)						PLN Total Installed Capacity %
	Steam	Gas Turbine	Combined C.	Geothermal	Diesel	Hydro	
	PLTU	PLTG	PLTGU	PLTP	PLTD	PLTA	
Year 2005	36.7%	12.6%	33.0%	2.3%	0.6%	14.7%	100.0%
Year 2006	39.8%	11.2%	33.4%	2.0%	0.6%	13.1%	100.0%

Year	Energy Production Share by Type of Fuel						PLN Total Production %
	HSD	MFO	Coal	Natural Gas	Geothermal	Hydro	
	%	%	%	%	%	%	
Year 2005	24.4%	9.2%	38.0%	16.7%	3.7%	8.1%	100.0%
Year 2006	20.7%	9.7%	43.2%	16.8%	3.7%	5.9%	100.0%
2005 -> 2006	↘	↔	↗	↔	↔	↘	

3-5

### 1.1 Existing Power Generation Facilities (4) Fuel Costs as of 2006 for Jamali

Fuel Type	Fuel Cost (Rp/kWh) by Fuel Type for Jamali 2006						
	Generation Energy	Fuel Consumption		Fuel Price		Fuel Cost	
		Unit	Consump.	Unit	Price	Billion Rp.	
HSD	16,574	K.Liter	4,212,302	Rp./Liter	5,556	23,404	1,412.1
MFO	7,717	K.Liter	2,059,781	Rp./Liter	3,521	7,252	939.7
Coal	34,526	Ton	16,821,687	Rp./kg	349	5,871	170.0
Gas	13,434	MMSCF	126,367	Rp./MSCF	24,112	3,047	226.8
Geo	2,975	-	-	Rp./kWh	525.6	1,564	525.6
Total	75,226					41,138	546.9

Source: PLN Statistical 2006

Geothermal (PLTP) is positioned as the average Fuel Cost in Jamali 2006 approximately.

3-6

### 3. Generation Expansion Plan

#### 1.2 Existing Power Generation Expansion Plan (1) Fast Track Program (6,900 MW in Jamali)

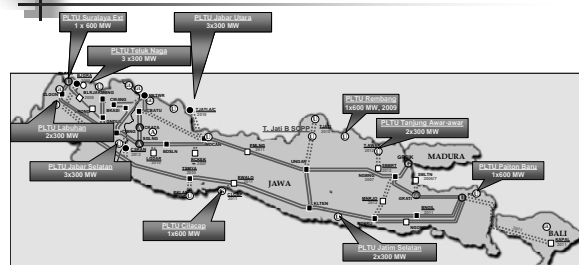

Ten Coal-fired Projects (6,900 MW) of the Fast Track Program are expected to be operation at least in the year of 2011 except Cilacap. 3-7

#### 1.2 Existing Power Generation Expansion Plan (2) Other PLTU (Coal) Projects

Project Name	Ins. Capa. (MW)	Op. Year
IPP Paiton III Extension Project	815	2012

3-8

#### 1.2 Existing Power Generation Expansion Plan (3) PLTP Development (Based on RUPTL and Others)

Project Name	Ins. Capa. (MW)	Op. Year
Kamojang #5	60	2012
IPP Cisolok-Cisukarame *	45	2011
IPP Patuha #1 ~ #3	60 x 3	2010, 11
IPP Wayang – Windu #2	110	2012
IPP Tang. Perahu #1 ~ #2 *	110 x 2	2011
IPP Tamos #1 *	50	2011
IPP Dieng #2 ~ #3	60 x 2	2010
IPP Bedugul #1	10	2010

Note: \* Bid was issued in June 2008 (JKT post 6/07).

9

#### 1.2 Existing Power Generation Expansion Plan (4) PLTGU (Gas) Development/Improvement

Project Name	Add. Capa. (MW)	Op. Year
T. Priok Extension	750	2012
M. Tawar Repowering	225	2011
M. Karang Repowering	750	2011

Above three projects are under going by JBIC finance.

3-10

#### 1.2 Existing Power Generation Expansion Plan (5) Java – Sumatra Interconnection

Project Name	Ins. Capa. (MW)	Op. Year
Java – Sumatra Interconnection	3000	2014, 15

3-11

#### 1.2 Existing Power Generation Expansion Plan (6) LNG – PLTG/GU Development

Project Name	Ins. Capa. (MW)	Op. Year
LNG – Bojanegara (Planning)		2014 (2015)

3-12

### 3. Generation Expansion Plan

#### 1.2 Existing Power Generation Expansion Plan (7) PLTA and Pumped Storage Development

Project Name	Ins. Capa. (MW)	Op. Year
Upper Cisokan Pumped Storage	1000	2013 (2015)
IPP Rajamandala	47	2012
PU Jatigede	55 x 2	2015

3-13

#### 1.3 (Power Tariff and) Fuel Prices

##### (1) Fuel Prices (2000 ~ 2006)

Year	Ex. Rate	HSD	MFO	Coal	Natural Gas	Geothermal
		\$/bbl	\$/bbl	\$/ton	\$/MSC	\$/kWh
2000	8,529 Rp/\$	11.06	7.12	18.02	2.55	0.0260
2001	10,266 Rp/\$	13.61	10.14	19.44	2.54	0.0289
2002	9,261 Rp/\$	24.15	19.35	23.73	2.54	0.0335
2003	8,571 Rp/\$	32.30	29.59	26.93	2.51	0.0369
2004	8,985 Rp/\$	32.37	30.04	25.68	2.37	0.0331
2005	9,751 Rp/\$	45.97	39.43	25.80	2.60	0.0473
2006	9,141 Rp/\$	97.92	61.48	36.74	2.65	0.0553

Source : PLN Statistics 2006, Bank Indonesia (Exchange Rate)

Oil-based fuel prices (HSD & MOF) have been increased by more than 8 times since the year 2000, while those of coal and geothermal have been twice.

3-14

#### 1.3 (Power Tariff and) Fuel Prices (2) Current Trend (Crude Oil)



Crude oil price has been soaring from the year 2007.

3-15

#### 1.3 (Power Tariff and) Fuel Prices (3) Current Trend (Coal)

##### Bukit Asam sells Coal at 80 US\$ a ton (JKT Post 2008.08.12)

- (1) Bukit Asam sold coal to the Tanjung Jati B power plant in Java at 80\$ a ton, its record price for the domestic market.
- (2) Coal prices have more than doubled in a year as demand from Asian utilities increased.
- (3) The record price "will be a reference when we negotiate the price for shipments to Suralaya" power plant next year.
- (4) Coal prices for the power station were raised 13 % starting from July 1, to 617,900 Rp (67 US\$) a ton.
- (5) Coal prices at Australia's Newcastle port, a benchmark for Asia, reached a record 194.79 US\$, in the week ended July 4.

3-16

#### 1.3 (Power Tariff and) Fuel Prices (4) Current Trend (LNG & Gas)

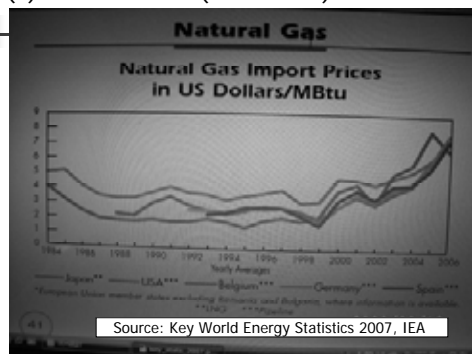

Source: Key World Energy Statistics 2007, IEA

3-17

#### 1.3 (Power Tariff and) Fuel Prices

##### (5) Current Trend

- All fuel prices (Gas, LNG, and Coal) have been increasing in line with the increase of crude oil price.

3-18

### 3. Generation Expansion Plan

#### 2.1 Candidates for Generation Expansion Plan

##### (1) Requirements for Future Candidates

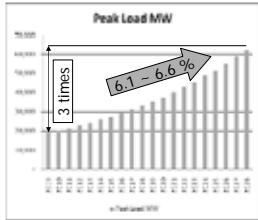

- Future Candidates**
- (1) A large-scaled,
  - (2) Less operation cost,
  - (3) Flexible operation, and
  - (4) Reliable operation
- Power Resources**

3-19

#### 2.1 Candidates for Generation Expansion Plan

##### (2) Fuel Prices for Generation Expansion Plan

Kind of Fuel	Price		Heat Content	
	USD	Cents/mKcal		
Coal	80.0 per Ton	1,509	5,300	Kcal/kg
LNG	10.0 per MMBTU	3,968	252,000	Kcal/mmbtu
Gas	5.0 per MMBTU	1,984	252,000	Kcal/mmbtu
HSD	133.0 per Barrel	9,222	9,070	Kcal/l
MFO	81.0 per Barrel	5,437	9,370	Kcal/l
Geothermal	0.0553 per kWh	6,430		
Nuclear		250		

Note: HSD & MFO prices are derived from Crude Oil Price assuming 95 US\$/bbl.

3-20

#### 2.1 Candidates for Generation Expansion

##### (3) Construction Cost for Generation Expansion Plan

Plant Type	Construction Cost (M.US\$)	Installed Capacity (MW)	Unit Constructi on C. (US\$/kW)	Expected Operatio n Year	Remark / Source
PLTU - Coal	1,400	815	1,718	2012	(1) IPP Palton III Extension Project (2) News release by TEPCO on Aug.04.2008 (3) Super Critical Conventional Coal Thermal (4) 30-year PPA
PLTN			2,083		(1) World Nuclear Association Report, 2005 (2) EIA (2004) used a starting point of 2083 US\$ per kW for its estimates in its "2004 Annual Energy Outlook"

3-21

#### 2.1 Candidates for Generation Expansion Plan

##### (4) Construction Cost for Generation Expansion Plan



Plant Type	Overnights Cost Updated Cost (\$/kW)
C&H	1,250
C10H	1,718
LNG	875
N10H	2,604
G150	500
PS 1&2	697
PS 3	647
PS 4	691
GE55	1,945
U-SIC	1,736

Iron & Steel Prices have been increased by 25 % from 2004 to 2007.

3-22

#### 2.1 Candidates for Generation Expansion Plan

##### (5) Screening Curve for Candidates

Fuel Prices Scenario Index	Medium Scenario							
	PLTU	LNG	PLTN	PLTG	PLTU10	PLTP	Insec.	
Installed Capacity	MW	600	750	1000	150	1000	55	3000
Fuel Type		coal	LNG	nuclear	HSD	coal	Geothermal	HVDC TL
Fuel Price	\$/MMBTU	3.80	10.00	0.63	23.24	3.80	16.20	3.80
Thermal Efficiency	%	35%	47%	33%	30%	35%	86%	35%
Variable O&M	\$/MWh	2.0	1.0	0.4	2.0	2.0	1.0	2.0
Fixed O&M	\$/kW.year	31.32	19.2	55.92	11.64	31.32	30.00	31.68
Investment Cost Inc. IDC	\$/kW	1,481	999	3,296	548	2,036	2,220	2,359

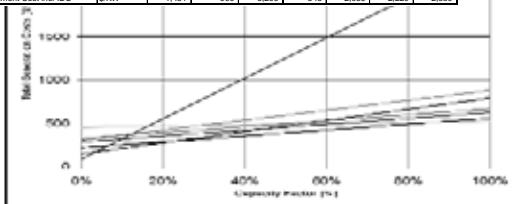

3-23

#### 2.1 Candidates for Generation Expansion Plan

##### (6) Comparison among Candidates

P. Type	Fuel Type	A large-S	Less OPC	Flexible	Reliable
PLTU	Coal(LRC)	⊙	○	△	○
PLTN	-	⊙	⊙	×	⊙
PLTG/GU	HSD/Gas	△ / ○	× / △	○	○ / ×
	LNG	○	△	○	△
PLTP	None	×	△	×	⊙
PLTD	HSD	×	×	⊙	○
PLTA	(RES)	○	⊙	⊙	×
P/S	None	○	△	⊙	○

3-24



### 3. Generation Expansion Plan

#### 2.1 Candidates for Generation Expansion Plan (7) Proposed Candidates and Operation Pattern

Power Plant	Capacity (MW)	Operation Pattern		
		Base L	Middle L	Peak L
PLTN	1,000	↔		
PLTP	55	↔		
PLTU Coal	600/1,000	↔	↔	
LNG TG/GU	150/600		↔	↔
PLTA (RES)	-		↔	↔
P/S	500			↔

3-25

#### 2.2 Generation Expansion Model (Draft) (1) Main Countries' Generation Share 2004

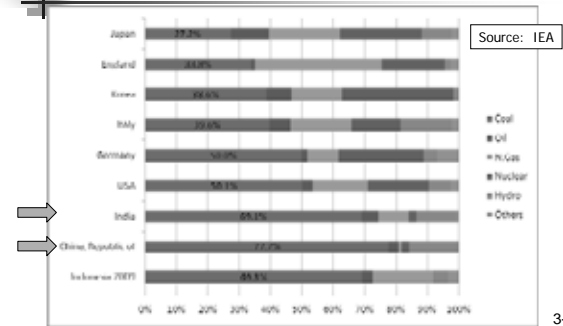

3-26

#### 2.2 Generation Expansion Model (Draft) (2) Comparison with China

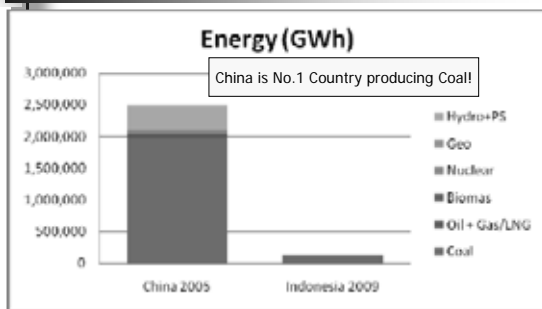

3-27

#### 2.2 Generation Expansion Model (Draft) (2) Comparison with China

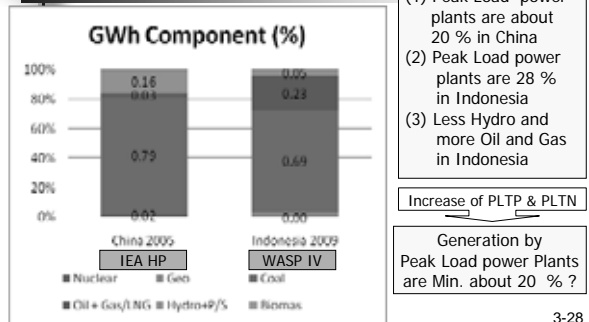

- (1) Peak Load power plants are about 20 % in China
- (2) Peak Load power plants are 28 % in Indonesia
- (3) Less Hydro and more Oil and Gas in Indonesia

Increase of PLTP & PLTN

Generation by Peak Load plants are Min. about 20 % ?

3-28

#### 2.2 Generation Expansion Model (Draft) (3) Indonesia 2028 Model

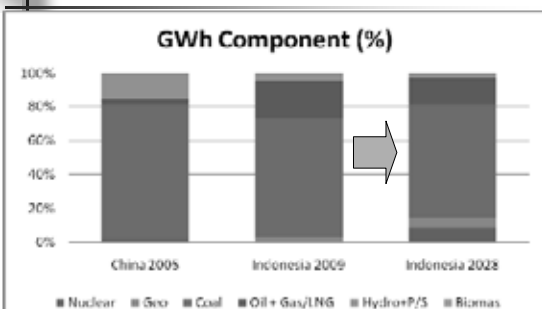

3-29

#### 2.2 Generation Expansion Model (Draft) (4) Generation Expansion Plan

	2009	2010	2011	2012	2013	2014	2015	2016	2017	2018	2019	2020	2021	2022	2023	2024	2025	2026	2027	2028	
C6H PLTU	600																				
C10H PLTU	1000			1	1	1	1	5	5	8	10	12	15	17	18	21	24	27	31		
LNG PLTG	750					1	2	3	4	4	4	4	4	6	6	8	8	10	10		
N10H PLTN	1000							1	1	1	1	2	2	2	3	3	4	4	5		
GE55 PLTP	55		6	6	6	10	12	14	16	18	20	22	24	26	28	30	32	34	36	38	
G150 PLTG	150																				
PS Pumped S.	500						1	2	2	4	6	6	6	6	6	6	6	6	6	6	
CIB3 PLTA	172											1	1	1	1	1	1	1	1	1	
CPSG PLTA	400											1	1	1	1	1	1	1	1	1	
CMDS PLTA	238											1	1	1	1	1	1	1	1	1	
MANG PLTA	360											1	1	1	1	1	1	1	1	1	
PLTA PLTA	300													3	3	6	6	6	7	7	
Java-Sumatra I.C.	600					4	5	5	5	5	5	5	5	5	5	5	5	5	5	5	

3-30

### 3. Generation Expansion Plan

#### 2.2 Generation Expansion Model (Draft) (4) Generation Expansion Plan

##### ■ Pumped Storage (PS)

Name	Installed Capacity	Construction Cost	Annual Generation
Upper Cisokan (PS-1 & 2)	1,000 MW	697 US\$/kW	2,400 GWh
Matenggen* (PS-3)	1,000 MW	647 US\$/kW (585 as of 1999)	905.2 GWh
Grindulu* (PS-4)	1,000 MW	691 US\$/kW (624 as of 1999)	905.2 GWh

\* : Source :Hydro Inventory and Pre-Feasibility Studies, June 1999

3-31

#### 2.2 Generation Expansion Model (Draft) (4) Generation Expansion Plan

##### ■ PLTA

Name	Location	Type	Unit Construction Cost (\$/kW)	Installed Capacity (MW)	Annual Energy (GWh)
Cibuni-3	W.J	RES	2,337	172	568
Cipasang	W.J	RES	1,333	400	751
Cimandiri-3	W.J	RES	1,630	238	600
Maung	C.J	RES	1,572	360	535
PLTA	-	RES	2,337	300	563

Source : Hydro Inventory and Pre-Feasibility Studies, June 1999

3-32

#### 2.2 Generation Expansion Model (Draft) (5) 2028 Model (WASP – Fixed )

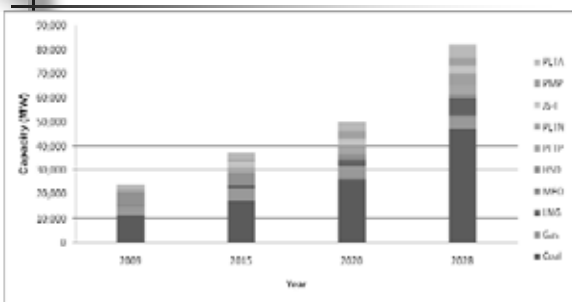

3-33

#### 2.2 Generation Expansion Model (Draft) (5) 2028 Model (WASP – Fixed )

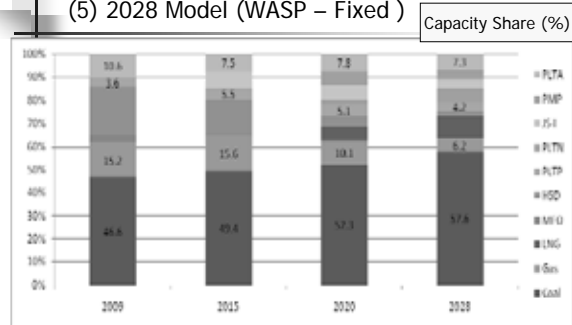

3-34

#### 2.2 Generation Expansion Model (Draft) (5) Indonesia 2028 Model

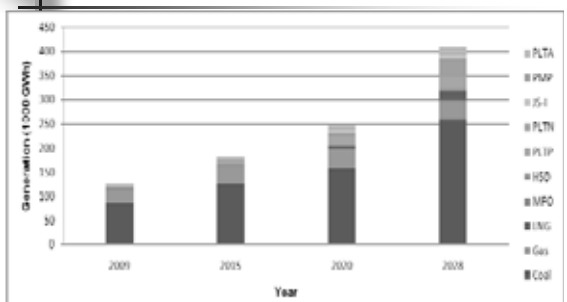

3-35

#### 2.2 Generation Expansion Model (Draft) (5) Indonesia 2028 Model

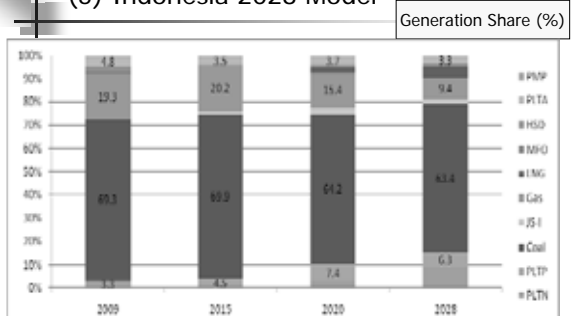

3-36

### 3. Generation Expansion Plan

2.2 Generation Expansion Model (Draft)  
(5) Indonesia 2028 Model

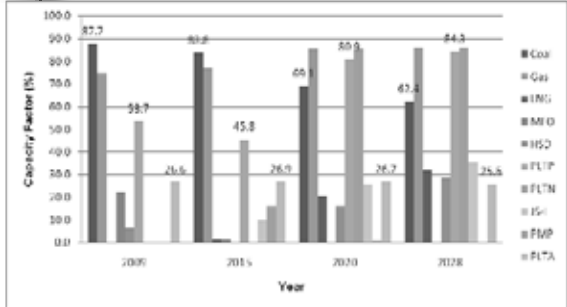

3-37

2.2 Generation Expansion Model (Draft)  
(5) 2028 Model (WASP – Fixed )

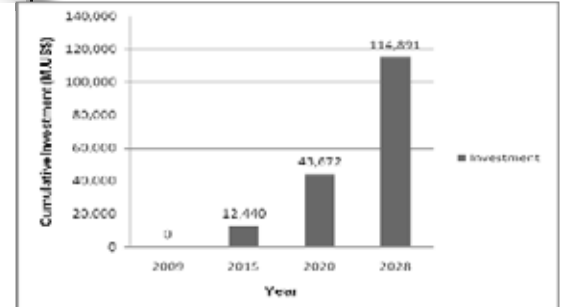

3-38

2.2 Generation Expansion Model (Draft)  
(5) Indonesia 2028 Model

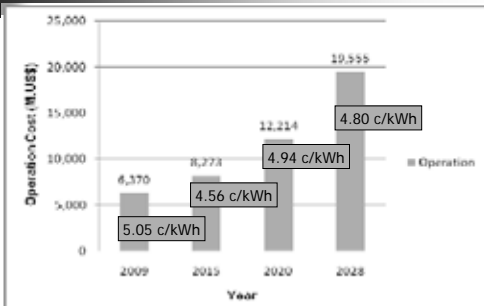

3-39

2.2 Generation Expansion Model (Draft)  
(5) Indonesia 2028 Model

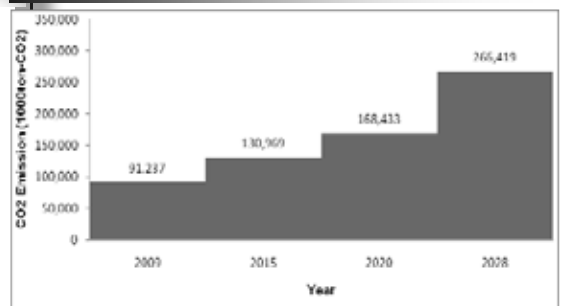

3-40

2.2 Generation Expansion Model (Draft)  
(7) CO2 Emission by Type of Fuel (Japan)

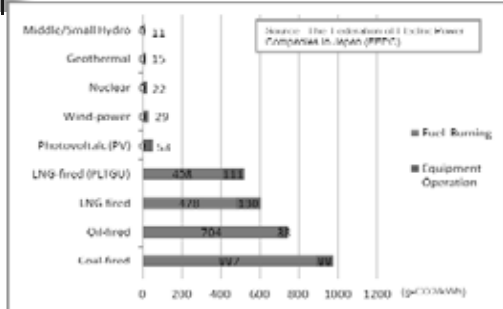

3-41

2.2 Generation Expansion Model (Draft)  
(8) 2028 Model Conclusion

- Cumulative Investment up to 2028 will be 115 Billion US\$.
- Generation by Peak Load Power Plants account for 19 % at 2028.
- Capacity Factor of Coal-fired will be 62.4 % at 2028.
- Annual operation cost at 2028 will be 23 Billion US\$ (5.78 US\$/kWh).
- CO2 emission at 2028 will be 266 M. ton.

3-42

### 3. Generation Expansion Plan

#### 2.2 Generation Expansion Model (Draft) (9) World Trend of Coal-fired Plants (1/2)

- In the U.S. utilities are building 28 coal-fired plants and another 66 are in early planning, as gas price hikes motivate new interest.
- German is building 16 new plants to come on line by 2012.
- In Italy, Enel is converting to coal from oil-fueled power plants.
- Britain has endorsed new coal.

3-43

#### 2.2 Generation Expansion Model (Draft) (9) World Trend of Coal-fired Plants (2/2)

- Over the past three years, China has added each year new coal plants equivalent to Britain's entire electricity-generating capacity.
- India has approved eight "ultra mega" plants which will add nearly half again to its present generating capacity.
- The United Arab Emirates ordered the Gulf's first coal plant last month.

Source: Jakarta Post, August 19, 2008

3-44

## 4. POWER SYSTEM OPERATION

SPEAKER: MR. KOYAMA YASUSHI,  
KANSAI ELECTRIC POWER CO., Inc.

## 4. Power System Operation

### Improvement of Power System Operation

### Today's Topics

In this 2<sup>nd</sup> Workshop

- Our Findings on System Operation
  - Voltage, Frequency, Outage and Losses
- Possible Countermeasures (briefly)
  - Under study for the next workshop

4-1

### Survey and Discussion with JCC and RCCs

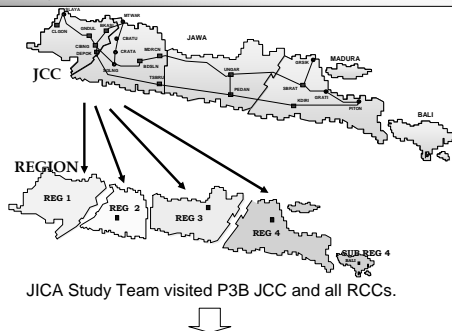

Discussion with P3B JCC and all RCCs  
Review of existing operation documents

4-2

### Condition of System Operation



New SCADA at JCC in 2006



On-line Information System



Rules and Reports

Structure, facilities and rules for operation are well conditioned.  
But, some problems in power quality exist.

4-3

## Voltage

### - Voltage - Current Condition

System voltage shall be maintained within following band

Nominal Voltage	Standard
500kV	+5%, -5%
150kV	+5%, -10%
70kV	+5%, -10%
20kV	+5%, -10%

4-4

4-5

# 4. Power System Operation

### - Voltage - Current Condition

**The number of substation with voltage drop**

Voltage	2002	2003	2004	2005	2006	2007	2008*
500kV (S/S)	103	158	149	145	75	60	23
150kV (S/S)	566	551	407	479	288	153	106
70kV (S/S)	319	248	198	207	169	252	34

\*As of March, 2008

**Assumed voltage drop at the peak time (night time) in 2008**

Voltage	RCC1	RCC2	RCC3	RCC4	Total
500kV (S/S)	0	0	0	0	0
150kV (S/S)	1	11	0	0	12
70kV (S/S)	4	0	0	6	10

Although there is a tendency to decline in recent years, the number of voltage drop is still quite large.

4-6

### - Voltage - Current Condition

Example of voltage profile at a 150 kV bus in Region 1.

Problem exists at day time rather than night time in Region1.

4-7

### - Voltage - Probable Reasons

Voltage problem is fundamentally due to the lack of reactive power supply

**Static Capacitors and Shunt Reactors**

Lack of long-term reactive balance study and installation plan

**Reactive output from generators**

Shortage of functional requirement in the grid code  
Generators not able to follow operational orders

4-8

### - Voltage - Possible Countermeasures

**Short-term Countermeasure**

Raise of standard voltage  
Raise of standard voltage at extra high voltage system  
Ex. 500kV -> 515kV

Incentives and penalties on reactive power supply  
Rules and structures so that IPPs follow operation order from P3B

**Long-term Countermeasures**

Installation plan of reactive supply equipment  
Installation based on long term reactive demand and supply balance  
(This will be explained in Technical Transfer Seminar)

Installation of on-load tap changer to step-up transformer  
On-load tap changer utilizes reactive output from generator

Installation of Power System Voltage Regulator (PSVR)  
PSVR utilizes reactive output from generator

4-9

# Frequency

4-10

### - Frequency - Current Condition

4-11

# 4. Power System Operation

**- Frequency - Current Condition**

**Governor Free (GF) Capacity**  
All generator shall be operated as GF mode, but no description for amount to be secured.

**LFC Capacity**  
Be determined through P3B meeting. 5% of the load is required for 2008.

**Reserve Margin**

Classification	Shall be operated within	Amount to be secured
Spinning reserve	10 minutes	Maximum unit
Spinning reserve + Cold reserve	4 hours	Maximum unit x 2
Spinning reserve + Cold reserve + Capacity reserve		Maximum unit x 2 + Margin

**UFR**  
Be set considering system frequency characteristics calculated from the record of frequency drop in the past.

4-12

**- Frequency - Current Condition**

**Deviation of Standard Frequency**

Year	2002	2003	2004	2005	2006	2007	2008*
The number of deviation	108	361	338	239	741	510	296

\*As of March, 2008

**[Record of 2007]**  
**F > 50.5 Hz (189 times)**  
 179 times of them were caused by load fluctuation  
**F < 49.5 Hz (321 times)**  
 252 times of them were caused by load fluctuation  
 69 times of them were caused by generator outage

↓ ↓

Lack of generation ability to respond to load fluctuation

4-13

**- Frequency - Current Condition**

**Generation Outage in 2007**

Item	Energy of generation outage (GWh)
Forced Outage	8,959
Maintenance Outage	2,987
Forced Derating	6,553
Scheduled Derating	434
<b>Total</b>	<b>18,933</b>

About 20% of annual generation

Generation outage and derating is one reason for fundamental lack of supply

4-14

**- Frequency - Probable Reasons**

**Lack of Governor Free (GF) Capacity (4-16)**  
GF Capacity seems to be insufficient.

**Lack of LFC Capacity (4-16)**  
LFC Capacity seems to be insufficient.

**Lack of generators of middle and peak type (4-17)**  
Proper amount of middle and peak type generators isn't secured.

**Operation order to IPP generators (4-17)**  
Difficult for JCC to order IPPs to change output.

**Output change of natural gas generators**  
Natural gas generator with pipeline is difficult to change output.

**Low ramp rate (4-18)**  
Actual ramp rate is lower than designed value.

**Inadequate calculation of System Frequency Characteristics (4-19)**  
System Frequency Characteristics may not be appropriate.

4-15

**GF Capacity and LFC Capacity**

No.	Plant	Capacity (MW)	LFC Capacity (MW)	Notes
1	PLTU Suralaya	1800	3 x 10	Normal
2	PLTA Saguling	700	4 x 25	Normal
3	PLTA Cirata	1000	8 x 20	Normal
4	PLTGU Gresik	1030	2 x 10	Normal
5	PLTU Paiton	800	0	Out of Control
6	PLTGU Grati	300	15	Normal
7	PLTGU Muara Tawar	400	0	Not Operated
8	PLTGU Priok Baru	1100	2 x 10	Out of Control
9	PLTGU Muara Karang Baru	400	10	Normal
10	PLTGU Tambak Lorok	208	2 x 7.5	Normal
11	PLTGU Gresik Baru	500	10	Normal
12	PLTU Tanjung Jati B	1320	2 x 15	Normal
13	PLTU PEC	1290	0	Not Operated
14	PLTU Java Power	1220	0	Not Operated
15	PLTGU Cilegon	740	0	Not Operated
16	PLTU Citacap	562	0	Not Operated
<b>Total</b>			<b>410</b>	

**GF Capacity**  
Generators without LFC control are mainly coal fired and operate with full output all the time.  
> No GF Capacity

**LFC Capacity**  
Required 850MW  
> Planned 410MW  
> Actual

Fundamental Lack of GF Capacity and LFC Capacity

4-16

**Breakdown of Generators in JAMALI**

Type	Owner					Ratio (%)
	IP	PJB	PLN	IPP	Total	
Hydro	1,103	1,283		150	2,536	11.5
Thermal (Steam)	7,498	5,209	1,598	4,520	18,825	85.1
(Combined Cycle)	3,900	2,100		4,370	10,370	46.9
(Gas Turbine)	2,676	2,727	740		6,143	27.8
(Diesel)	846	382	858	150	2,236	10.1
Geothermal	76				76	0.3
	360			405	765	3.5
<b>Total</b>	<b>8,961 (40.5%)</b>	<b>6,492 (29.3%)</b>	<b>1,598 (7.2%)</b>	<b>5,075 (22.9%)</b>	<b>22,126 (100%)</b>	

Many base load type (Lack of peak and middle)

Generators with gas pipeline (Difficult to change output)

20% owned by IPP (Difficult to order)

4-17



# 4. Power System Operation

### Ramp rate of generators

Some generators have lower ramp rate than designed value.

↓

Low ability to change output in accordance with load change.

No	Name	Ramping Rate (MW/min)	
		Designed Value	Status of Actual Value
1	PLTP DRAJAT	0.55	same
2	PLTP KAMOJANG	1	same
3	PLTP SALAK	1	same
7	PLTGU TAMBAKLOROK	2	same
8	PLTGU GRESIK 1&2	1	same
9	PLTGU GRESIK 3&4	2	same
10	PLTU MUARAKARANG 1 - 3	2	-
11	PLTU MUARAKARANG 4 & 5	3	-
12	PLTU SURALAYA 1 - 4	5	-
13	PLTU PRIOK	2	-
14	PLTU PERAK	1	-
15	PLTU PAITON 1-2	4	-
16	PLTU PAITON 5-6	10	Slower
17	PLTU PAITON 7-8	10	Slower
18	PLTU Tanjung Jati	20	Slower
19	PLTG GILTIMUR	2	-
20	PLTG MUARATAWAR	5	-
21	PLTG GRESIK	5	-
23	PLTA CIRATA	120	Faster
24	PLTA SUTAMI	22.5	Faster
25	PLTA SAGULING	12	Faster
26	PLTA MRICA	4.5	same

4-18

### System Frequency Characteristics

#### System Frequency Characteristics (System Stiffness)

Year	2002	2003	2004	2005	2006	2007
System frequency constant (MW/Hz)	569	540	543	608	613	696

System capacity is not considered  
⇒ Constant shall be represented as (%MW/Hz)

Data is processed through root mean square (RMS)

System Frequency Characteristics may not be appropriate.

It is used to determine required amount for load shedding.

4-19

### - Frequency - Possible Countermeasures

[Frequency control under normal condition]

Application of penalty for generators  
Penalty for generators not complied with requirements and/or violation of operation orders

Bidding classified by operation type ← Induction for investment of peak/middle type  
Bidding considering peak and middle type generators

Introduction of specific price schedule for IPPs ←  
Capacity fee based on contracted and available capacity  
Specific tariff considering peak and middle type operation

[Frequency control under emergency condition]

Proper calculation of system frequency characteristics

Detailed analysis of system frequency characteristics

4-20

# Outage

4-21

### - Outage - Current Condition (1)

#### SAIDI and SAIFI in Java (excluding Bali)

Item	2001	2002	2003	2004	2005	2006
SAIDI (minutes/customer/year)	510.0	499.2	322.2	250.2	224.4	164.4
SAIFI (times/customer/year)	12.24	9.26	7.90	6.67	5.88	4.23

**SAIDI and SAIFI in Japan**

**SAIDI in Developed Countries**

4-22

### - Outage - Current Condition (2)

#### Main reason for outages by year

	2002	2003	2004	2005	2006	2007	2008*
Nature	68	48	51	54	42	28	44
Defect of Facility	130	136	114	113	108	95	55
Animals	16	19	7	9	9	9	3
HF	3	4	11	3	10	3	1
Kite	21	18	13	7	10	9	4
Overloading	9	13	6	16	3	0	0
Trees	3	2	3	1	1	3	1
Relay malfunction	1	16	11	9	8	9	0
Others	50	29	31	24	11	3	1
<b>Total</b>	<b>301</b>	<b>285</b>	<b>247</b>	<b>236</b>	<b>202</b>	<b>159</b>	<b>109</b>
<b>Load Curtailment</b>	<b>18</b>	<b>9</b>	<b>9</b>	<b>26</b>	<b>29</b>	<b>9</b>	<b>0</b>
<b>Manual Load Shedding</b>	<b>19</b>	<b>10</b>	<b>10</b>	<b>34</b>	<b>19</b>	<b>61</b>	<b>17</b>
<b>*OLS</b>	<b>0</b>	<b>13</b>	<b>6</b>	<b>16</b>	<b>3</b>	<b>9</b>	<b>2</b>
<b>Automatic load shedding</b>	<b>42</b>	<b>6</b>	<b>15</b>	<b>25</b>	<b>21</b>	<b>15</b>	<b>7</b>
<b>Total</b>	<b>79</b>	<b>38</b>	<b>40</b>	<b>101</b>	<b>72</b>	<b>94</b>	<b>26</b>

OLS : Load shedding system against over load \*As of March, 2008

Many outages are caused by the problem of facilities

4-23

## 4. Power System Operation

**- Outage - Current Condition (3)**

**Load shedding and load curtailment in 2007**

Item	Region						Total
	Region1		Region2	Region3	Region4		
	Jakarta	West Jawa			East Jawa	Bali	
Automatic Load Shedding	162	50	562	135	110	100	1,120
Manual Load Shedding	11,284	1,396	2,131	198	734	57	15,800
Load Curtailment	0	0	161	1,276	464	0	1,901
<b>Total</b>	<b>11,446</b>	<b>1,446</b>	<b>2,854</b>	<b>1,609</b>	<b>1,308</b>	<b>157</b>	<b>18,821</b>

MWh

Quite a large outage are caused by load shedding and load curtailment

4-24

**- Outage - Current Condition (4)**

The process for report and countermeasures after occurrence of outages is conditioned.

4-25

**- Outage - Probable Reasons**

Aged Deterioration  
Aged deterioration  
Lack of spare parts

Bad quality of equipment and manufacturers  
Suppliers with bad equipment  
Insufficient support from manufacturers  
Too many manufactures

Supply Shortage  
Load curtailment cannot be avoided because of shortage of power supply

Violation of N-1 Criteria  
Some outages are caused by OLS because of violation of N-1 Criteria

Calculation of required amount of load shedding  
System frequency characteristics shall be calculated in proper manner

4-26

**- Outage - Possible Countermeasures**

Measure for same type of equipment  
Defect of equipment tends to occur on same type of equipment  
Detailed analysis of cause of failure  
Countermeasure to same type of equipment

Enhancement of Quality Management System  
Reinforcement of technical standard (SPLN)  
Quality Management System involving procurement department

Cooperation with Manufacturers  
Priority of procurement from local manufacturers  
Joint technical development and research with manufacturers

Planned installation of facilities based on N-1 Criteria

Appropriate calculation of system frequency characteristics

4-27

Losses

4-28

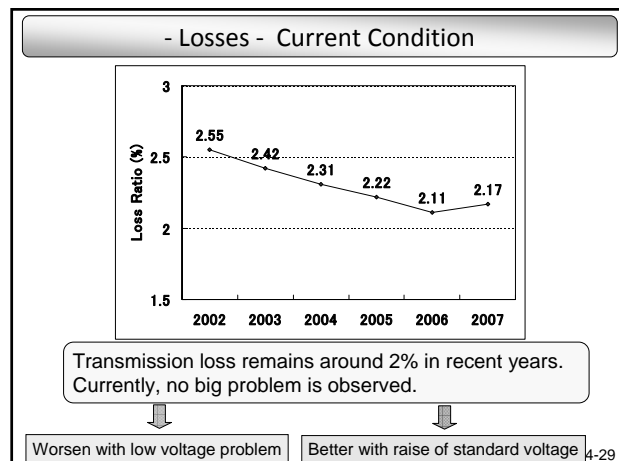

## 4. Power System Operation

### **SUMMARY**

JICA study team has found...

- Sophisticated Operation Systems
  - New SCADA, RAPSODI
- Well-established Rules
  - Aturan Jaringan, ROT, EOB, EOT etc.
- Some difficulties on System Operation
  - Voltage Drop, Frequency Deviation and Outage
    - Basically due to lack of adequate facilities
- Possible Countermeasures
  - will be explained in detail in the 3<sup>rd</sup> Workshop

4-30

## 5. POWER SYSTEM PLAN

SPEAKER: MR. TANAKA YUKAO,  
NEWJEC INC.

## 5. Power System Plan

### Java-Bali Power System



**★ Characteristics**

- Long distance of about 1,000 km to west –east direction.
- Large Power flow toward west direction
- Mainly Depending on long-distance Northern AC 500 kV transmission Line
- System has stability Problem

**★ Change of Situation**

- Coal fire plants under crash program
- UP Cisokan Pumped Storage power Station
- Interconnection with Java- Sumatra
- Introduction of new type Large Power Plant(Nuclear)

**★ Review of System Study**

- Study based on reviewed data using PSS/E
- Reliability of the hole power system with respect to stability of frequency and voltage 5-1

### Proposal of System study for System Planning

Confirmation and/or derive the followings, taking into account future projects in the Cambodian and neighboring countries' power system.

- ◆ Reliability of the Indonesian power system with respect to stability of frequency and voltage
- ◆ Reactive support requirements at substations at peak and off-peak times
- ◆ Capacity of such components as conductors, transformers, circuit breakers, etc.

5-2

### Example of System Reliability Criteria

In accordance with the above, the Consultant will carry out power flow analysis and clarify the followings:

- Sufficient capacity of main components such as conductors and transformers to ensure that power flow does not exceed capacity limits under normal conditions or disturbance situations (N-1 rule)
- Sufficient capacity of reactive compensation equipment, such as shunt reactance and/or capacitance to ensure that voltages at substations, do not exceed voltage
- Sufficient capacity of circuit breakers to ensure that short circuit currents do not exceed their capacity, in three-phase short circuit faults.

5-3

### Power System development (System Analysis)

◆ Development of the integrated optimal system Reinforcement plan with Criteria Reliability

- ★ Optimal Plan should be developed up to 2028
  - ◆ Key Year of 2010,2015 ,2020 and 2028 should be analyzed
- ★ "PSS/E" soft wear should be used for Analysis
- ★ Reliability Criteria
  - ◆ Total power system should be stable in case of any Equipment or Root Down Accident

5-4

### Expected Output from System Study

- Suitable Reinforcement of the 500kV trunk transmission line with economic
  - > Recommendation for Introduction of new methods
- Enhancement of Reliability of Whole Java- Bali system
  - > Recommendation of Simple Protection Method for avoiding large Power- Drop Out

5-5

### JAVA BALI 500kV SYSTEM year 2028

-System Capacity : Around 60,000MW - ( Just for reference)

At least, Two Routs of 500kV T/L might be required

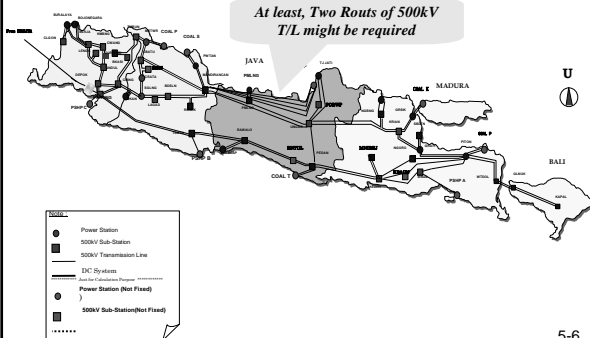

Legend:

- Power Station
- 500kV Sub-Station
- 500kV Transmission Line
- DC Systems
- Power Station (Not Filled)
- 500kV Sub-Station(Not Filled)

5-6

# 5. Power System Plan

## Power System development (Main Concept)

Comparison of several reinforcements measure mainly from the View point of Installation Cost, Flexibility and Realization

	Cost	Flexibility	Technical	O&M
DC	⊙	⊙[BTB]	○	○
Ultra High Voltage	△	○	△[Loss]	△
500kV T/L	○	○	⊙	⊙

★ Introduction of Method for enhancing Local Demand for achieving Block Balance 5-7

## Situation of DC System

### User Need of long distance bulk power Sending

- Previous Generation -

	Reliability	Cost	Technical	Capacity	O&M
DC	△	△	○	△	△
AC(HV)	○	○	○	⊙	○

⇒ AC(KV) : Russia(750), Korea(1000) and Japan(1000kV Design) etc  
 ⇒ DC : Baltic and FennoScan etc (Mainly Cable)

- Current Generation -

	Reliability	Cost	Technical	Capacity	O&M
DC	○	⊙	○	⊙	○
AC(UHV)	○	△	○	⊙	△

⇒ DC : Adaption of DC System for main Projects  
 ⇒ AC : Significance of Environmental Impact (Large Size based on Saturation of Insulator function, EMS & Corona Loss)

5-8

## Rough Comparison of AC/DC

Picture of AC Tower and DC Tower

5-9

## World's Main DC Facilities

5-10

## Relation between Transmission Capacity and DC Voltage in the World HVDC Project

5-11

## JAVA BALI 500kV SYSTEM year 2028

-System Capacity : Around 60,000MW - (Just for reference)

5-12

# 5. Power System Plan

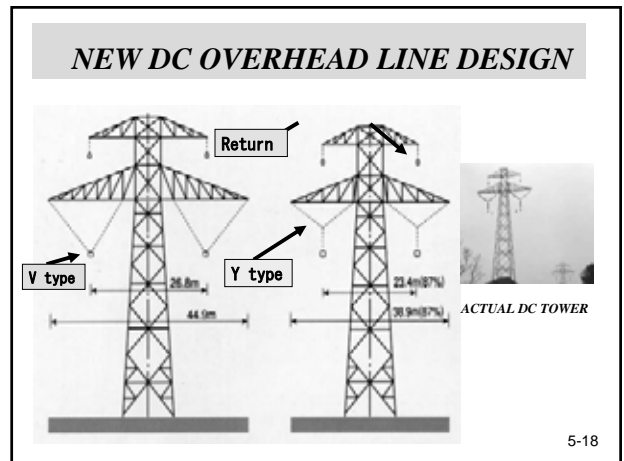
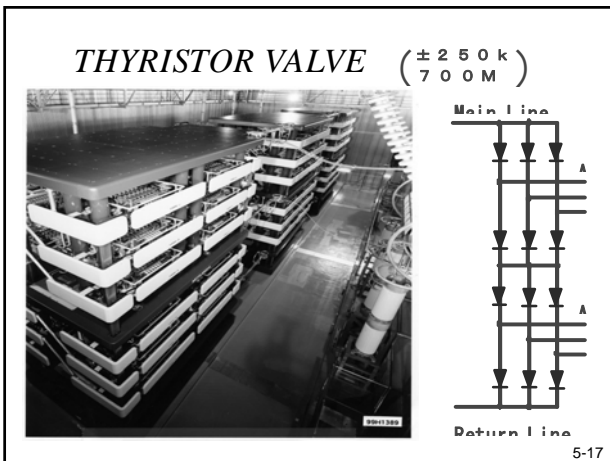
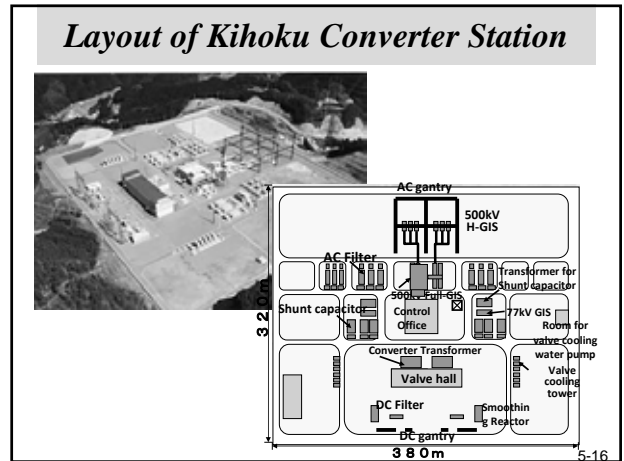
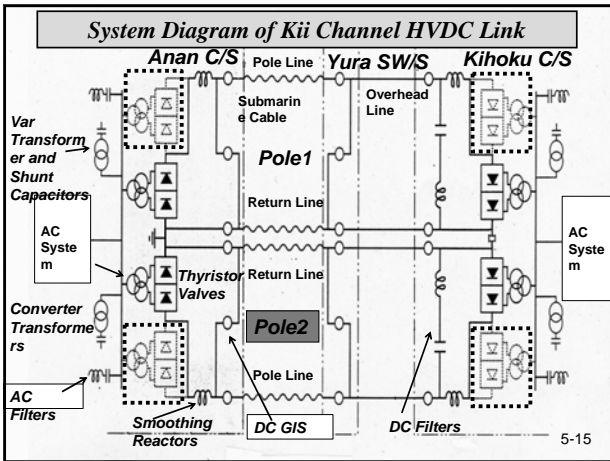
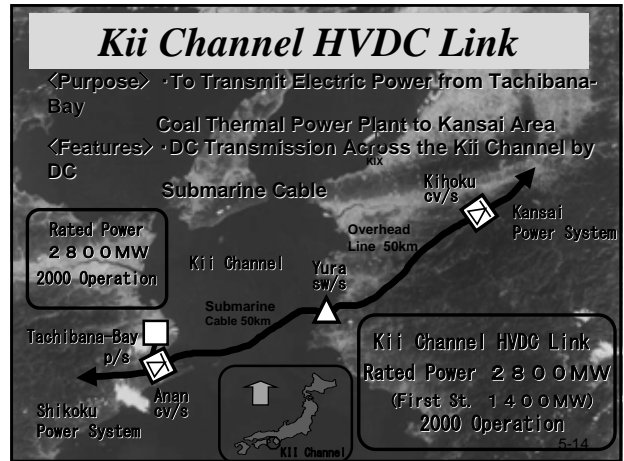
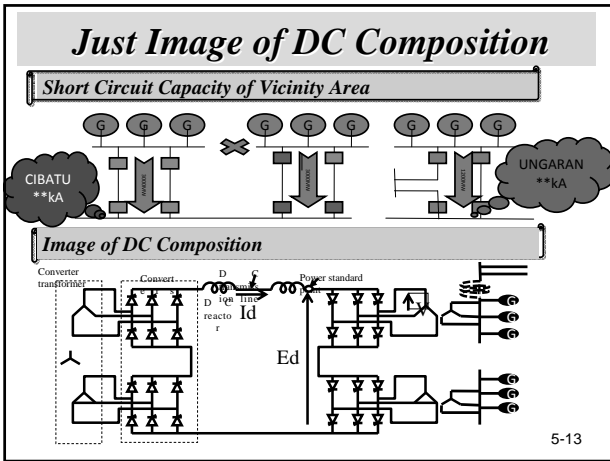

## 5. Power System Plan

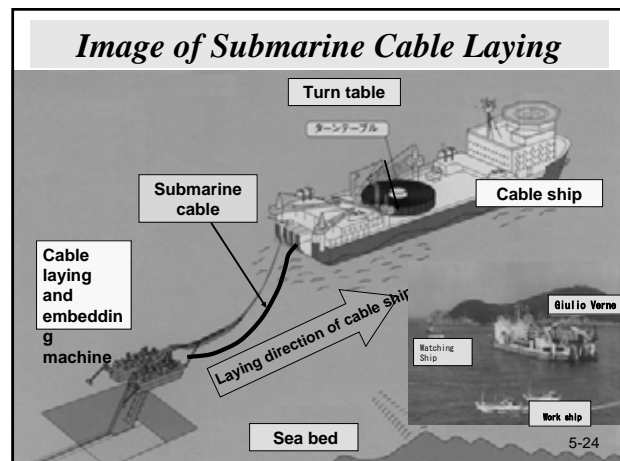
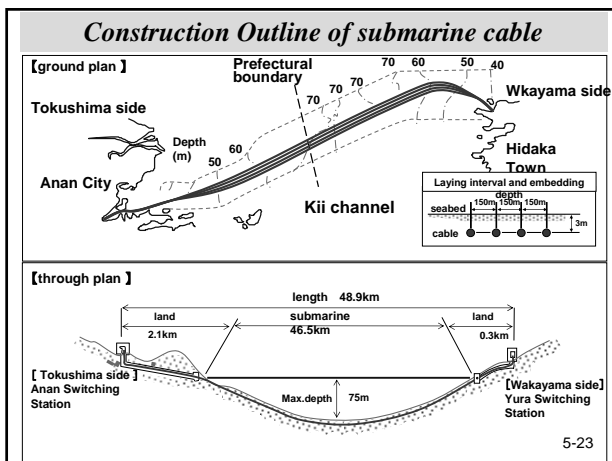
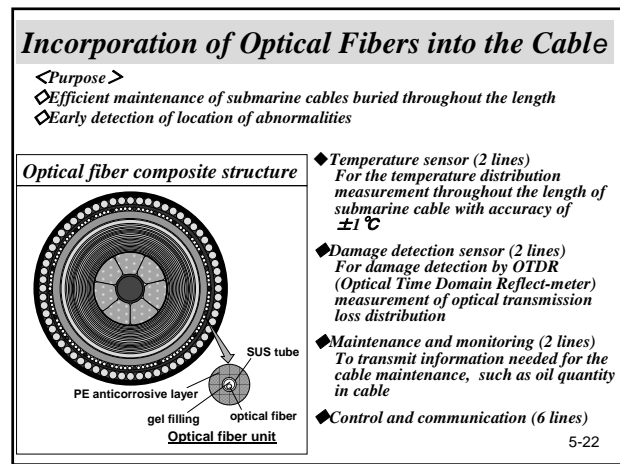
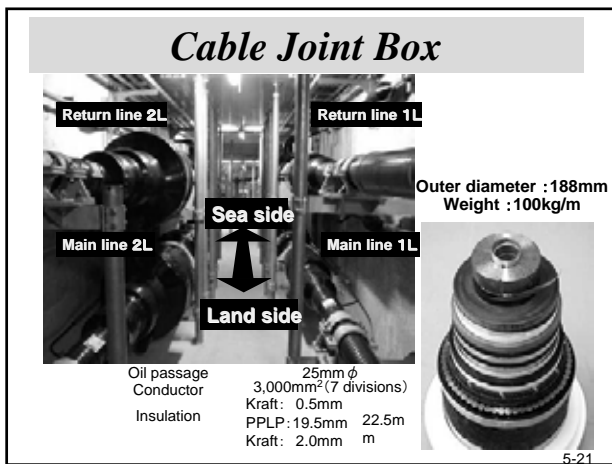
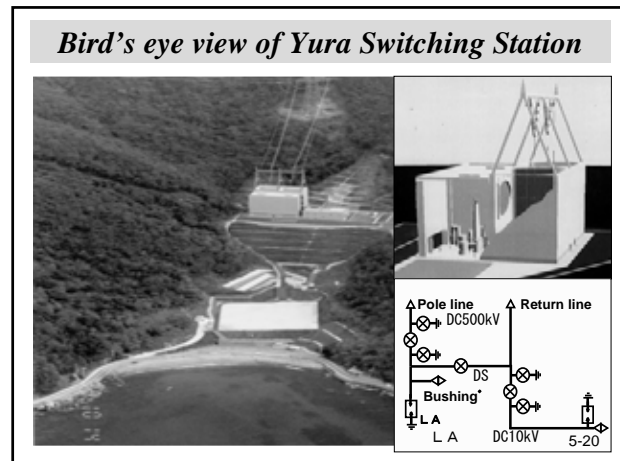
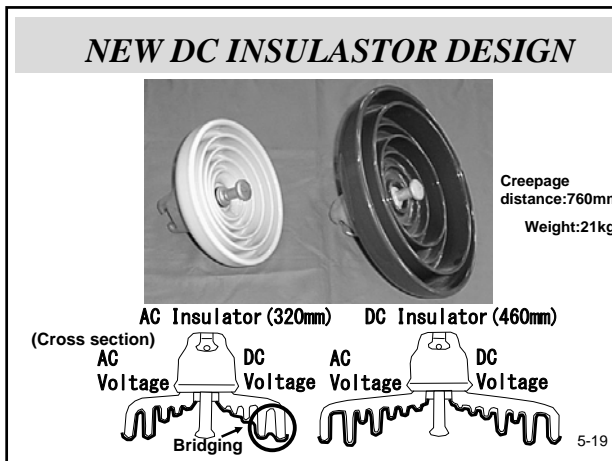



# 5. Power System Plan

## Uncoiling of Submarine Cable



Length and weight of cable coiled around turntable: 50km, 5,000t

5-25

## Cable Unloading (for $\Omega$ measurement)

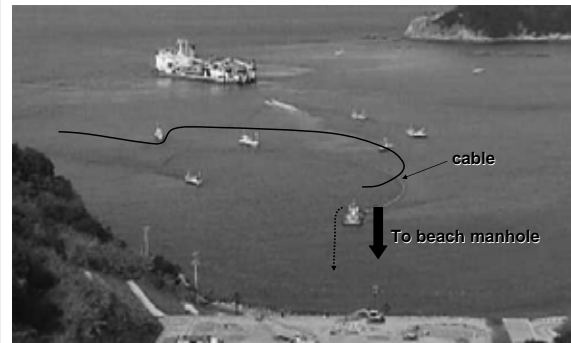

5-26

## Evaluation of Radio Noise Radiation

- 1/400 Scale Reduction Model -

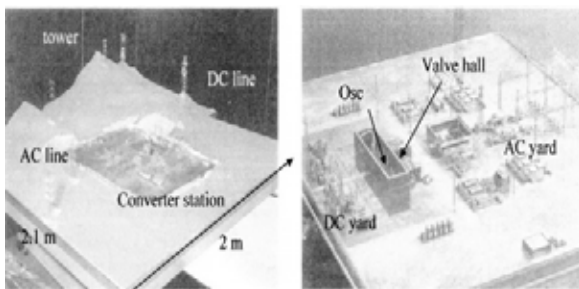

General view of model

Partial view of converter station

5-27

## Commutation of inverter operation

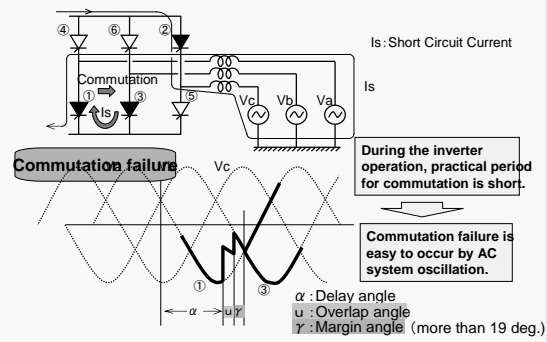

5-28

## Developed continuous operation system

Adaptation  $A\gamma R$  Calculation of  $\gamma$  margin angle from current and voltage wave Correction of conventional control Control  $\gamma$  margin angle

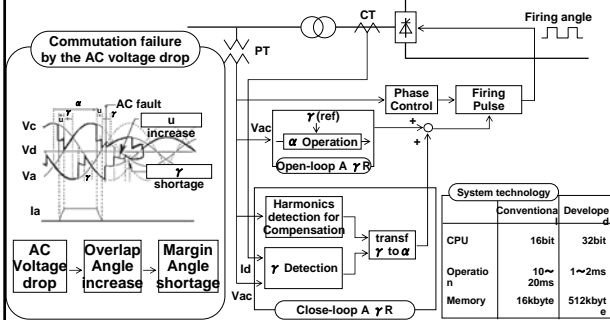

5-29

## Performance Record of DC-System Continuous Operation Control

### Result of DC Continuous Operation Control

No.	Date	Location	Power (MW)	Current (kA)	Voltage (kV)
1	7/4/00	Kita-Yamato2L	1033	117	0.22
2	7/4/00	Kita-Yamato2L	0.33	12	0.85
3	7/4/00	Kita-Yamato2L	0.33	13	0.85
4	8/5/00	Mitsui-Yamato2L	0.33	14	0.80
5	8/8/00	Ohshu	0.65	15	0.65
6	8/8/00	Kita-Ohshu2L	0.65	16	0.78
7	8/7/00	Osoboh	0.75	17	0.75
8	8/7/00	Kita-Yamato2L	0.22	18	0.80
9	8/10/00	Saiki-Kanama2L	0.85	19	0.85
10	8/17/00	Mitsui-Yamato2L	0.22		

### Response of DC-System Continuous Operation Control

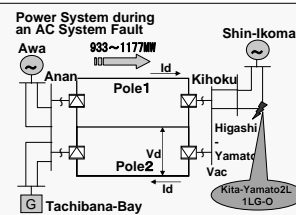
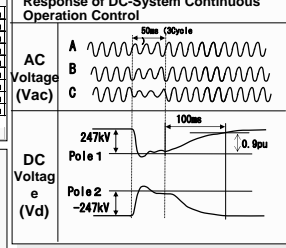

**DC voltage recovers in 100ms after fault removal**

5-30

## 5. Power System Plan

Stabilization of power system by HVDC		
	Contents of control	Effect
<b>PM</b> Power Modulation	Inputting frequency deviation of both converter station. ↓ Extraction of power oscillation element. ↓ Control DC power to restrict power oscillation.	Restraint of power oscillation
<b>EFC</b> Emergency Frequency control	Inputting frequency deviation of both converter station when power system is divided. ↓ Controlling DC power to decrease frequency deviation.	Frequency improvement
<b>EPPS</b> Emergency Power Preset Switch	Receiving EPPS signal from power stability system in Shikoku. ↓ Controlling DC power.	Frequency improvement

5-31

### Lightning Attacked the Neutral Line Removal of the Fault by MRTB Operation

**<Situation >**  
 •Date : Aug. 5. 2000  
 •Action Rely : Current Differential Relay (87NL) MRTB (close → open)  
**<Before Fault >**  
 •Monopolar Operation  
 •Transmission Power : 680MW

**<Operation >**  
 •Lightning Attacked the Neutral Line  
 •Protection Device (87NL) Detect the Fault Current.  
 •MRTB was Closed and Transferred the Fault Current.  
 •MRTB was Opened and Cut Off the Fault Current.

5-32

### CONSTRUCTION SCHEDULE

Year		1995	'96	'97	'98	'99	2000
Anan Converter Station	Civil Engineering Works		Land, Base				
	Electric Works				Tower, Equipment Installation		
Kihoku Converter Station	Civil Engineering Works		Land, Base				
	Electric Works				Tower, Equipment Installation		
Yura Switching Station	Civil Engineering, Electric Works		Land, Building, Truss				
Submarine and Land Cables	Civil Engineering Works		Tunnel				
Overhead Lines	Towers			Base, Assembly			
	Lines						
Commissioning Test							July

5-33

### Image of Tentative Protection System

**Protection for Frequency Drop**  
 ⇒ Stiffness: Around 2,000MW [=60,000MW\*Gap Rate(0.6)\*6%] NPP

**Protection for Whole System Collapse**  
 Step 1: Send Trip Signal for Load Shedding  
 Step 2: Detection of Step out Forces → CB Trip

5-34

### Example of Countermeasures

★ **First Countermeasure : Sending trip signal to Dispatch Feeder**

$$LS(MW) = RP(MW) - SS(MW)$$

Where RP: Sending Power / SS: System Stiffness or Stable restriction / LS: Load Shedding

→ For instance, Load Shedding might be set based on three condition taking the flowing condition into account

- \* Assumption of the savior case
- \* Consideration of the upper side limit of Frequency
- \* Avoidance of large fluctuation of Frequency

- **Level one:** Power flow is between BMW- A MW > Load Trip Signal of B-AMW
- **Level second:** Power flow is between CMW-BMW > addition trip of C-A MW
- **Level third:** Power flow is between DMW- CMW > additional trip of D-A MW

5-35

### Middle Power System for Dispatching

- Sample Concept for reference-

◆ **Base on the preposition, rough study was carried out for the possibility for introduction of higher middle system voltage compared to current 150kV voltage.**

ovinsi	Residence	Industry	Commercial	Social	Gov't Offices	Public	Total	Area	kW/km <sup>2</sup>
Bali	951.93	87.38	938.67	38.83	60.42	47.80	2125.03	5449.37	59
Java Timur	6574.85	8737.33	2016.17	408.41	169.62	416.72	18323.11	46689.64	60
Ira Tengah dan Yogyakarta	6121.55	4040.69	1274.14	384.02	118.4	475.01	12415.81	35932.86	53
Java Barat dan Banten	9343.1	17761.26	2363.94	398.34	186.15	246.01	30298.80	45943.69	100
Jaya Raya & Jenggerang	8655.1	8029.36	7480.28	735.6	730.85	279.71	25880.91	740.29	5321
JaMali Total	31646.53	38656.02	14043.2	1965.2	1265.44	1465.25	89043.66	134755.85	101

The Current Demand Density by Area

◆ **Rough Assumption of heavy load demand area in Indonesia Demand Density and possible length of dispatching line**  
 [Tolerable Current of Dispatching line - > 300A]

Density(Length)	Current	Future
	5MVA/km <sup>2</sup> (6km)	20MVA/km <sup>2</sup> (3km)

5-36

## 5. Power System Plan

### Example of Dispatching System

First considering the above mentioned demand density and based on the dispatching theme to uniform demand density area as mentioned in Figure 4.3.4-1, optimal bank combination was calculated taking the following items into consideration roughly:-

- \*Reduction of install cost including additional distribution substation and dispatching feeders-
- \*Evaluation of related system losses-

Figure 4.3.4-1 : Example of Dispatching system-  
Maximum Current of one Feeder (F) : 500A (Precondition)

Light Load Area: F=2 → F=4 → F=10 → Heavy Load Area

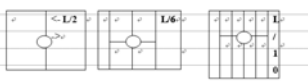

5-37

### Optimal Bank Combination

#### 1. Precondition

\*Cost of Distribution Tr:  $T_n$  (MVA) 10, 20, 30, 50, 100

$$P(T_n) = (0.3 + 0.7(T_n/10)^{0.3/4}) * 10^{**2} + 1.5T_n(10^{**3})$$

\*Loss of Tr

$$LI(T_n) = 3.6812(T_n)^{**0.6879364} \quad \text{Charge Loss}$$

$$LC(T_n) = 14.3645(T_n)^{**0.6986798} \quad \text{Current Loss}$$

\*Construction Cost for Substation (Excluding Tr)

$$\text{Land Price} = 750000d + 51000(\$)$$

$$\text{Required Space } 30000m^2 \quad Z(\$ / m^2) = 25d + 1.7 \quad d = \text{Demand density (MW/km}^2)$$

$$\text{House Building} = 587000(\$)$$

\*Equipment Cost

$$150KV \text{ Line Bay} : 487000(\$) \quad 150KV \text{ Bus coupler} : 420000(\$)$$

$$150KV \text{ Tr bay} : 326000(\$)$$

-20KV Switchgear-

$$\text{Tr } 2^{nd} : 21533(\$) \quad \text{PD, Ar} : 37400(\$) \quad \text{Bus sect} : 19267(\$)$$

$$\text{H.Tr} : 17000(\$) \quad \text{Feeder} : 20400(\$)$$

5-38

### Optimal Bank Combination

#### 1. Substation for Distribution

\*Optimal Bank Combination

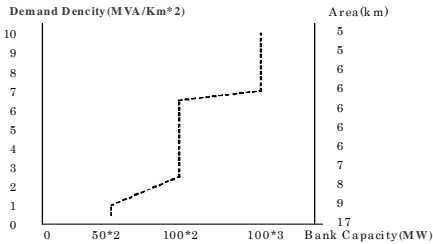

5-39

### Introduction of Higher Middle system Voltage(1)

◆ Maximum length of middle dispatching system between trunk substation and dispatching substation.

-> Considering protection relay, tolerable voltage drop etc, maximum voltage drop of 5% was assumed with the capacity of 100MVA, 3Bank, L.F: 90% for dispatching substation and Maximum dispatching length was calculated roughly.

Base on these assumption, the result of rough comparison of each medium system voltage is shown in Table 4.3.4-2.

Middle System Voltage (Kv)	Sending Capacity [Impedance Base 1000MVA]	Max Length (Km)	Bank Combination of Trunk Substation	Number of Dispatching Substation for Trunk Substation	Rough Line Length [Km]	Required Trunk Substation	Syst Loss
150	760MVA [0.08+j0.9]	50	500MVA * 3 Unit	5	6-9	Many (Around 25)	Large
220	MVA [0.05+j0.6]	70	750MVA * 3 Unit	8	9-12	Middle (Over 10)	Medium
275	1360MVA [0.04+j0.5]	90	1000MVA * 3 Unit	10	9-15	Little (Under 10)	Small

5-40

### Introduction of Higher Middle system Voltage(2)

◆ In addition, sending capacity rate of each voltage is as follows

-Sending Capacity rate of 220kV system voltage :

$$\text{Twice of the capacity of 150kV, one fifth of capacity of 500kV} \\ (220/150)^{**2}; (500/220)^{**2} = 2.15 : 5.17$$

-Sending Capacity rate of 275kV system voltage :

$$\text{Three times of the capacity of 150kV, one thirds of capacity of 500kV} \\ (275/150)^{**2}; (500/275)^{**2} = 3.36 : 3.31$$

⇒ Therefore, from the sending capacity ratio of existing voltage level, 275kV system would be suitable for next higher middle voltage as well.

⇒ As summary, 275kV should be recommended to introduce as higher middle system voltage in the future from the above consideration, simplification of system voltage level, install cost reduction and reduction of system losses as well.

⇒ In addition, regarding to extreme heavy demand density Area, more higher voltage such as 500kV should be considered to introduce directory from the view point of economic and technical based on more realistic demand density condition for further study.

5-41

### Other Main Recommendation Issues for further study

⇒ Utilization of DC System as BTB Operation

⇒ F/S for DC connection with Kalimantan

⇒ Consideration of applicable stability criteria

⇒ Enhancing the Supply-Demand Balance of Block areas

⇒ Elaboration of previous recommended issues

- Introduction of DC & new Medium system Voltage - 5-42

## 5. Power System Plan

*Just For your reference*

### Operation of Converters and Control of DC Transmission

5-43

### Operation of Rectifiers

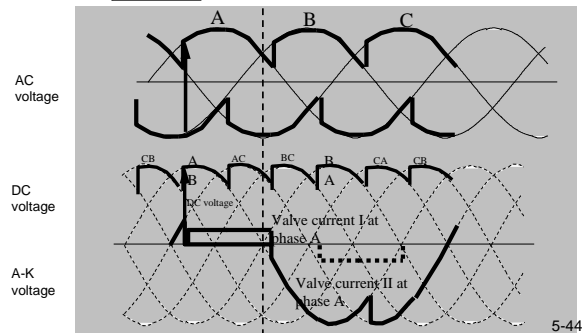

### Operation of converters

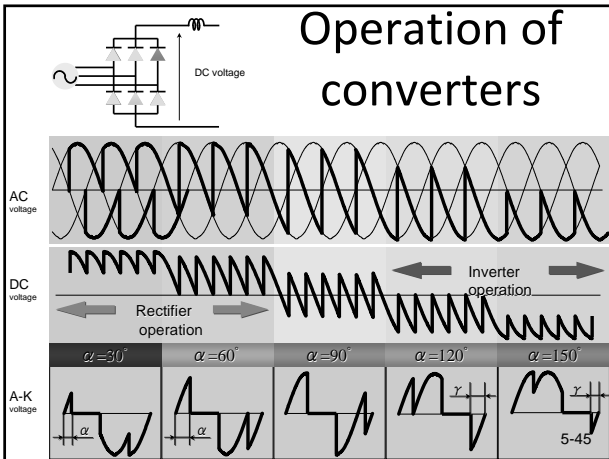

### Control Characteristics of Converters(3)

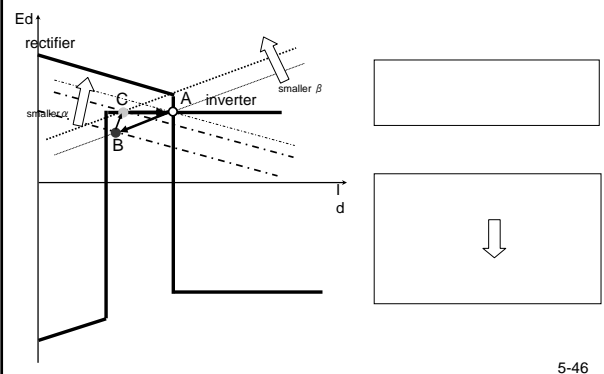

*Just For your reference*

### Sub-Marine Cable Design

5-47

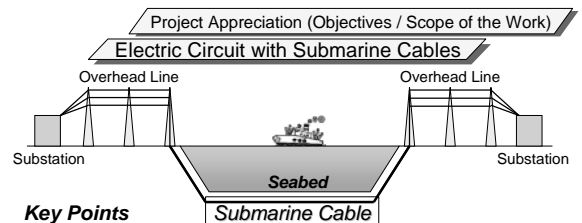

#### Key Points

1. Capabilities against the electrical stress:  
**Less than other equipment**
2. Maintenance:  
**Not be possible after having been laid in the sea**
3. Cost:  
**High** (Submarine Cable and Cable-laying Work)

5-48

# 5. Power System Plan

### Collection of Data and Information

**Seabed conditions**

- Fault
- Geology
- Topography
- Irregularity
- Obstacles

**Others**

- Traffic
- Meteorology
- Regulations
- Others

**Sea conditions**

- Water depth
- Ocean current
- Tidal current
- Wave height

**Side Scanning Sonar**

Output of Sono-Prove

5-49

### Project Appreciation (Site Survey)

(Example: Kii Channel HVDC)

**Side Scanning Sonar**

**Rough Survey**

Depth of Fish: Shallow

**Detail Survey**

Depth of Fish: Deep

**Check Survey**

Depth of Fish: Deep

**More Distinct**

5-50

### 2 Analysis Study

Collected Data/Information

Preparation of united map

5-51

### Project Appreciation (Condition of Malacca Strait)

Outline of Condition and Concern in Malacca Strait

	Outline	Concern
Seabed condition	Non major fault Sand or Mud (in large area)	Sand bank Sand/Reef wave (height:4 – 7 m or more)
Sea condition	Water depth: less than 50 m Ocean current: slow	Tidal current: fast
Others	Wind: Gentle (on the average)	Squall / Thunderstorm Bush (around the seashore) Fishing bank Seabed mine

5-52

### 3 Scenario of the Site Survey

Step -1: Decision of Area for Cable-laying Work

Requirements for Cable-laying Work

✓Water depth	: Shallow
✓Ocean/ Tidal current	: Slow
✓Wave height	: Calm
✓Geological formation (Cable laying stratum)	: Sand or Mud
✓Fault	: Non major fault
✓Surface of Seabed	: Flat
✓Obstacles	: Non
✓Meteorological phenomena	: Calm
✓Connection to overhead line	: Easy

5-53

### Project Appreciation (Submarine cable)

Characteristic of each Submarine Cable

	Solid	OF	XLPE	
Experience (Submarine cable)	DC	○ many	△ few	× non
	AC	△ few	○ many	△ few
Electrical Performance	○ less than OF	◎	? lack data	
Mechanical Performance	○ less than OF	◎	? lack data	
Applicability for long length	◎	○ upper length 50 – 100 km	? lack data	
	longest length (experience)	250 km Baltic Channel	50 km Kii Channel	

5-54

## 6. ECONOMIC AND FINANCIAL STUDY

SPEAKER: MR. NISHIDA MASARU,  
NEWJEC INC.

## 6. ECONOMIC AND FINANCIAL STUDY

### Financial Consideration on Power Development Plan

### Table of Contents

#### Capital Requirement of Investment

- Power Plant
- Transmission

#### Operating Expenses

- Power Plant
- Transmission

#### Issues of Financing Power Development for Next 20 Years

- Financing Sources
- Issues of BPP
- Strategy for Financing Power Development

6-1

### Capital Requirement of Investment

### Assumptions for Estimation

- Power plant development plan is after Generation Expansion Model (Draft), incl. Capital and O/M costs, as discussed in Sec.4
- Investment cost with IDC is shown on the year in which the plant (unit) is put in operation
- IPPs are included, while Jawa-Sumatra Interconnection does not include power plant (coal-fired) development cost
- Projects listed in RUPTL2007-16 are separated from those considered in Generation Expansion Model (Draft)

6-2

6-3

### Capital Requirement for Power Plant Development

### Asset Formation shown by Cumulative Investment

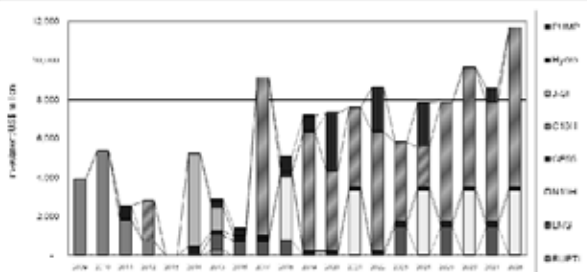

Not to be quoted

6-4

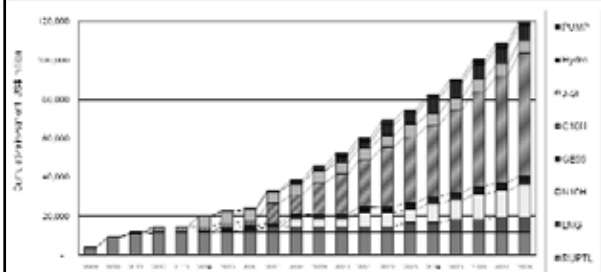

Not to be quoted

6-5

## 6. ECONOMIC AND FINANCIAL STUDY

### Asset Formation shown by Depreciation

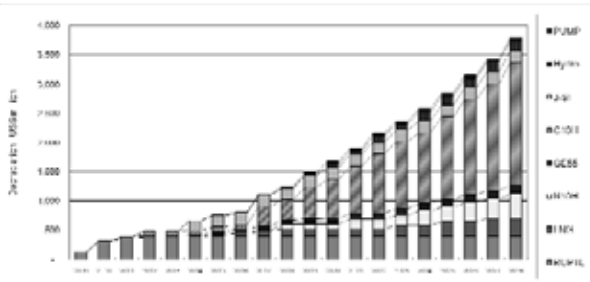

Not to be quoted

6-6

### Capital Investment for Transmission Lines

Tentatively show plan in RUPTL

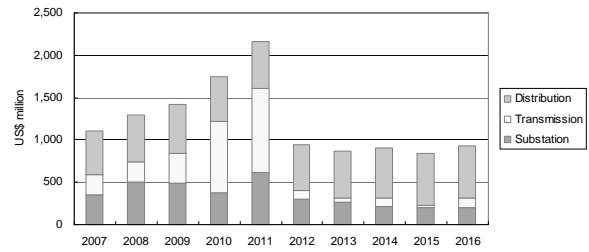

Not to be quoted

## Operation Expenses

### Assumptions for Estimation of Operation Expenses

- Depreciation and interest of current assets and debts are constant
- T/L, D/L, SS investment and related costs are after RUPTL and assumed constant after 2016
- Management overhead is not included
- Loan conditions are assumed as below

	RUPTL	LNG	NUC	GEO	COAL	J-SI	CC60	HYDRO
rep period	10	20	30	20	15	20	20	30
interest r.	8%	6%	6%	10%	8%	6%	8%	6%

6-8

6-9

### Estimated Operation Expenses

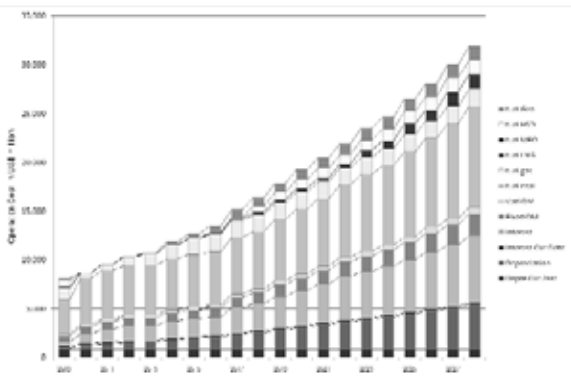

Not to be quoted

6-10

### Estimated Operation Expenses

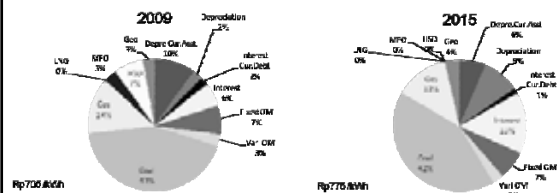

Not to be quoted

6-11



## 6. ECONOMIC AND FINANCIAL STUDY

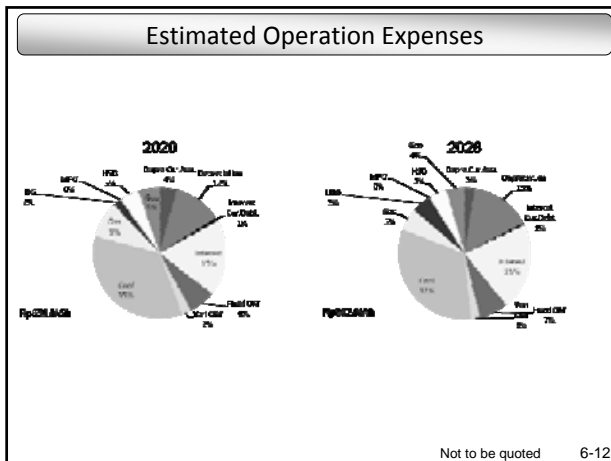

## Issues of Financing Power Development for Next 20 Years

6-13

**What We Understand**

**On Income Side**

- Electricity Tariff will be "Full Cost" level, except for R-1 ("Full Cost" being BPP)
- Subsidy will be in place for foreseeable future
- Regional Tariff and Regional Subsidy will possibly be determined by Regional Government

**On Expense Side**

- Operation expenses will decrease by "Fuel Shift"
- Diversification of primary energy works in the Opposite
- Future investment requirement will increase progressively

6-14

**PLN's Financing Source for Power Plant Development**

- Own resources
- Loan (Two-step, Gov't, Commercial)
- Bond (and Guaranteed Notes)
- Lease
- IPP (PPA & ESC)
- Fast Track Program, a new approach?

6-15

**PLN's Financing for Power Plant Development 1**

**Own resources**

- Limited by nature
- Mostly for T/L and local currency portion

**Loan (Two-step, Gov't, Commercial)**

- Huge capital requirement may exhaust ODA resources
- Environmentally friendly PJs have advantages (+CDM)
- Possibility of commercial bank loan can be explored more : Market Confidence in PLN is the key

**Bonds and Guaranteed Notes**

- Market Confidence in PLN is the key

6-16

**PLN's Financing for Power Plant Development 2**

**Lease**

- Relatively expensive choice
- Successful case of Tanjung Jati-B should be studied

**IPP (PPA & ESC)**

- For base-load plant development (upper limit?)
- Competition among bidders should be encouraged

**Fast Track Program?**

- Unique in Exporter Credit + Commercial Loan with Gov't Guarantee
- Demonstrating Gov't determination to solve power shortage?

6-17

## 6. ECONOMIC AND FINANCIAL STUDY

### Issues of BPP 1

#### Current BPP

- Being Basis of Tariff, determines PLN's Income
- Including only Depreciation cost as capital expense component
- Only value of depreciating (= existing) facilities
- Does not allow for the cost of rapidly expanding future facilities

6-18

### Issues of BPP 2

#### Change to New BPP

- Raising level of BPP to allow for future investment, realizing "Consumer Supported Financing"
- Amendment to regulations on PLN's accounting is necessary, e.g., "accelerated depreciation" for definite period
- Another way of showing Government determination
- Market confidence would be bolstered, which may ease difficulties of seeking finance from commercial banks

6-19

### Strategy for Financing Power Development

- ODA loans for environmentally friendly projects (low CO2 emission + due consideration on social/ environmental impacts)
- Possibility and benefit of CDM must be exploited
- Improving investment climate (environment) for both domestic and foreign capital, to encourage IPP
- Revising BPP to allow for future investment need
- Operation cost must be minimized to gain consumers support for raised tariff(BPP) by introduction of better facility management schemes (eg.asset management)
- Other possibility, Lease and Fast Track, should be studied for further applications

6-20

## 7. STRATEGIC ENVIRONMENT ASSESSMENT

SPEAKER: MR. OHWADA TAKASHI,  
JAPAN NUS Co., LTD

## 7. Environmental & Social Considerations

### Environmental & Social Considerations

#### Objective

#### Incorporate Environmental & Social Considerations into the Study on the Optimal Electric Power Development in Java-Madura-Bali Area through Strategic Environmental Assessment (SEA)

(= Optimal Electric Power Development Scenario should not be identified solely for economic & engineering reasons)

7-1

#### ◆ What is Strategic Environmental Assessment (SEA)?

Strategic Environmental Assessment (SEA)	Environmental Impact Assessment (EIA)
Applied to Policy, Plans & Programs (Upstream of Decision-Making)	Applied to Individual Projects (Downstream of Decision-Making)
General Assessment	Specific Assessment
Area Basis and/or Long-Term	Site and Project Specific
Can Consider Synergistic Impacts	Difficult to Consider Synergistic Impacts
Can Consider Cumulative Impacts	Difficult to Consider Cumulative Impacts
Greater Flexibility for Alternatives	Constrained to Specific Projects

7-2

#### ◆ What to do in SEA of Power Sector?

##### ■ Identify Potential Environmental Impacts associated with each Type of Power Generation

ex. SO<sub>2</sub>, NO<sub>x</sub>, PM, CO<sub>2</sub> from Coal-Fired,  
Loss of Habitats/Involuntary Resettlement for Hydro,  
Radiation from Nuclear,  
H<sub>2</sub>S from Geothermal

##### ■ Recommend Measures to Prevent/Reduce/Mitigate Potential Environmental Impacts

ex. FGD, Low-NO<sub>x</sub> Burner, ESP for Coal-Fired,  
Cooling Tower to reduce Thermal Effluents from Thermal,  
Information Disclosure to obtain Consent for Resettlement for Hydro

7-3

#### ◆ What is Outcome of SEA?

##### ■ Provide Input to Identification of Alternative Electricity Development Scenarios to Avoid Significant Environmental Impacts

##### ■ Recommend Environmental Protection Measures to the Optimal Electric Power Development Scenario to Make it Environment-Friendly

7-4

#### ◆ Can SEA suggest the maximum capacity of coal-fired power generation to be allowed in Jamali ?

##### [Unfounded Upper Limits in Several Reports]

##### 1. How can we assess impacts on air quality when we do not know locations of individual P/Ss?

Extension of existing P/Ss may deteriorate local air quality down to unacceptable levels, while construction of the same capacity at new locations as new P/Ss may not pose threats to the health.

7-5

#### ◆ Can SEA suggest the maximum capacity of coal-fired power generation to be allowed in Jamali ?

##### [Unfounded Upper Limits in Several Reports]

##### 2. How can we assess impacts of coal-fired P/S when we do not know the present level of air pollution?

We can not accommodate coal-fired P/S at location with serious air pollution.

7-6

## 7. Environmental & Social Considerations

### ◆ How to predict local air quality under operation of new P/S?

Acceptable Increase =  
Air Quality Standard – Present Air Quality

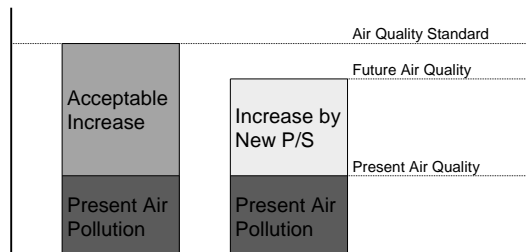

7-7

### ◆ Can SEA suggest the maximum capacity of coal-fired power generation to be allowed in Jamali ?

[Unfounded Upper Limits in Several Reports]

3. How can we assess impacts on air quality when we do not know efficiency of ESP at each P/S?

We can accommodate more P/Ss in Jamali, if more efficient ESP is introduced to them (This is also the case for FGD and Low-NOx burner).

7-8

### ◆ Can SEA suggest the maximum capacity of coal-fired power generation to be allowed in Jamali ?

[Unfounded Upper Limits in Several Reports]

4. How can we set a limit on CO<sub>2</sub> emission from P/Ss when Indonesia does not have a legally-binding target for its CO<sub>2</sub> emission reduction under Kyoto Protocol?

Indonesia reserves a right to emit CO<sub>2</sub> for its industrial development. We can not limit the maximum CO<sub>2</sub> emission from power generation.

7-9

### ◆ How can we “reduce” CO<sub>2</sub> emission from thermal power generation?

[Efficient use of fuel]

- 1) Improvement of generation efficiency.
- 2) Natural gas than oil. Oil than coal.

[Recovery of CO<sub>2</sub>]

- 1) CCS (Carbon Capture & Storage)
- 2) CO<sub>2</sub> sequestration by forests

7-10

### ◆ Can SEA suggest the maximum capacity of coal-fired power generation to be allowed in Jamali ?

[To Justify the Maximum Acceptable Capacity]

We need to know;

- 1) Locations of individual P/Ss, and
- 2) Present level of air pollution, and
- 3) Efficiency of ESP, FGD and Low-NOx Burner, or
- 4) CO<sub>2</sub> emission reduction target for the power sector.

7-11

### ◆ Does hydroelectric power generation suppress global warming?

[HEPPs may NOT be “clean” as we thought]

1. All reservoirs of HEPPs release CH<sub>4</sub> into the atmosphere.

Influx of excessive nutrients to reservoir → Proliferations of phytoplankton/floating plants → Anaerobic decomposition → CH<sub>4</sub> emission

7-12

## 7. Environmental & Social Considerations

### ◆ Does hydroelectric power generation suppress global warming?

[HEPPs are NOT always friendly to the earth]

2. CH<sub>4</sub> has GWC (Global Warming Coefficient) of 21.

(1 ton of CH<sub>4</sub> = 21 tons of CO<sub>2</sub>)

Too much CH<sub>4</sub> emission from reservoir →  
Offset CO<sub>2</sub> emission reduction by HEPP →  
HEPP will be an emission source of GHG

7-13

### ◆ Does hydroelectric power generation suppress global warming?

[Some HEPPs may be emission source of GHG]

As results,

- We can not rely CO<sub>2</sub> emission reduction solely on HEPP.
- HEPP with a large reservoir can not be registered as CDM project.

7-14

### ◆ Is geothermal power generation environment-friendly?

[No emission of SO<sub>2</sub>, NO<sub>x</sub>, PM and CO<sub>2</sub> from geothermal power generation]

But,

- H<sub>2</sub>S emission → Offensive odor, corrosion of metal, negative impacts on local vegetation.
- As and Hg effluent → Toxic to aquatic fauna.

7-15

### ◆ Why is geothermal power generation promoted?

[Geothermal power generation is not necessarily environment-friendly]

- Geothermal power generation has its specific environmental problems, and it is promoted because geothermal energy is domestic energy.

7-16

## 8. POWER DEVELOPMENT SCENARIO

SPEAKER: MR. YAMAOKA SATOSHI,  
NEWJEC INC.

# 8. Power Development Scenario

## Power Development Scenario

8-1

### Contents

- 1 Concept
- 2 Base scheme
- 3 Optimization study
- 4 Suggestion for follow-up projects

8-2

### 1. Concept

```

graph TD
    A[Demand forecast] --> B[Power source development scenario]
    B --> C[Transmission system development scenario]
    B --> D[Strategic environmental assessment]
    C --> E[Power development Base scheme scenario]
    D --> E
    E --> F[Alternative scenario and optimization]
            
```

**Flow chart for Alternative Scenario and optimization**

8-3

### Target

- ◆ Oil free to avoid high oil fuel price
- ◆ Annual demand increase 6.5 %
- ◆ Reserve margin 30 %
- ◆ More capacity:  
22.3 GW in 2006 to 81.2 GW in 2028, 3.64 times
- ◆ More production energy:  
104.8 TWh in 2006 to 406.6 TWh in 2028, 3.88 times

8-4

### Elements

**Best Mix of Power Sources**

8-5

### Power sources

**Current players**

Sources	Base	Middle	Peak
Coal	↔		
Geothermal	↔		
Small hydro	↔		
Gas	↔	↔	
Oil		↔	↔
Reservoir hydro		↔	↔

8-6



## 8. Power Development Scenario

Power Sources			
Future players			
Sources	Base	Middle	Peak
Coal	←→		
Geothermal	←→		
Small hydro	←→		
Reservoir hydro		←→	
Gas (LNG)		←→	
Oil			←- - - - ->
Pumped Storage			←→
Nuclear	←→		
Solar, wind, biomass	←→		
Transmit from Sumatra	←→		

8-7

Plan	
Sources	Development Plan
Coal	Main substitution for oil, but base load
	FTP is on-going, 6,900 MW in Jamali by 2010/11
	Low rank domestic coal will be applied.
	<b>Issues</b>
	Procurement is uncertain.
	Logistics shall be established.
	Common use of existing infrastructure is economic in extension of running plants. Environmental impact, air pollution is anticipated.

8-8

Plan	
Sources	Development Plan
Natural Gas	LNG enables peak load supply.
	Three gas plants, MK, MT, TP, total 1,678 MW are on going.
	Bojanegara CC, 4@750 MW, is planned.
	<b>Issues</b>
	Procurement is uncertain.
	LNG logistics shall be established.
	Less air pollution than coal.

8-9

Plan	
Sources	Development Plan
Geothermal	To be advanced in policy, 5 % on energy basis.
	Existing 835 MW , prioritized 785 MW, and feasible 2,015 MW, total 3,635 MW.
	Capacity ratio 5 % will be attainable in 2025.
	IPPs are expected more than PLN's own development.
	<b>Issues</b>
	High initial cost, but fuel is domestic.
	Sites are in protected areas. No CO <sub>2</sub> emission.

8-10

Plan	
Sources	Development Plan
Hydro	Large potential of reservoir type and run-of-river.
	No reservoir type constructed after Cirata II, 1998.
	Potential studies executed before 1998.
	<b>Issues</b>
	High initial cost, but no fuel cost.
	LARAP is essential.
	Clean energy, no CO <sub>2</sub> emission.

8-11

Plan	
Sources	Development Plan
Pumped Storage	Large potential of pumped storage in Jamali.
	Upper Cisokan PS, 1000MW is ready for construction.
	Next PS shall be studied more.
	<b>Issues</b>
	Coal thermal power will be used for pumping.
	Economic in combination with coal or nuclear.
	LARAP is essential. Clean energy, no CO <sub>2</sub> emission. Sea water PS has more environmental issues.

8-12

## 8. Power Development Scenario

Plan	
Sources	Development Plan
Nuclear	Base load supply with a large unit.
	About 4,000 MW is assumed by 2028.
	Delay from road map, first unit operation later than 2018.
	<b>Issues</b>
	High initial cost, but low fuel cost.
	Safety assessment is essential.
	Clean energy, no CO <sub>2</sub> emission.

8-13

Plan	
Sources	Development Plan
Biomass	Future base load supply.
	Bio fuel or phylogenetic waste
	Primary energy target 5 % by 2025.
	<b>Issues</b>
	High fuel cost.
	Logistics of fuel is challenging.
	Clean energy, no CO <sub>2</sub> emission.

8-14

Plan	
Sources	Development Plan
Renewable; small hydro, solar & wind	Future base load supply.
	Primary energy target 3 % by 2025.
	More studies needed for site identification.
	<b>Issues</b>
	High initial cost, but no fuel cost.
	Clean energy, no CO <sub>2</sub> emission.

8-15

Plan	
Sources	Development Plan
Transmission from Sumatra	Future base load supply.
	Capacity 3,600 MW in mine-mouth coal in Sumatra.
	Transmit 3,000 MW to Jamali in 2015.
	<b>Issues</b>
	Future expansion plan of DC transmission line.
	High initial cost.
	No air pollution in Jamali.

8-16

2. Base Scheme	
Long term target:	Follow primary energy policy or power generation development plan that Indonesian government or PLN has announced.
Short term target :	Oil fuel use is suppressed.

8-17

Target of Primary Energy Consumption for Power Sector					
Description	RUKN	RUPTL	Energy Outlook	Estimation in Base Scheme	Modification in Base Scheme
Target year	2010	2016	2025	2028	2028
Oil	2	0.2	3.1	0.2-3	0.2-3
Coal	71	72.1	64.9	65-72	56-66
Gas	12	18.6	18.8	12-19	12-19
Geothermal	7	9.1	13.1	5-7	5-7
Hydro	8			4-8	4-8
Others (Nuclear, etc)	0	0		4-9	4-9
Transmit from Sumatera	0	0	0	0	6-9
Total (%)	100	100	100	100	100

8-18

# 8. Power Development Scenario

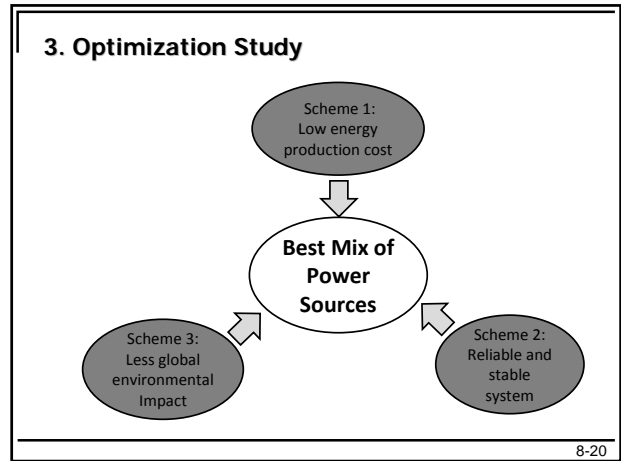
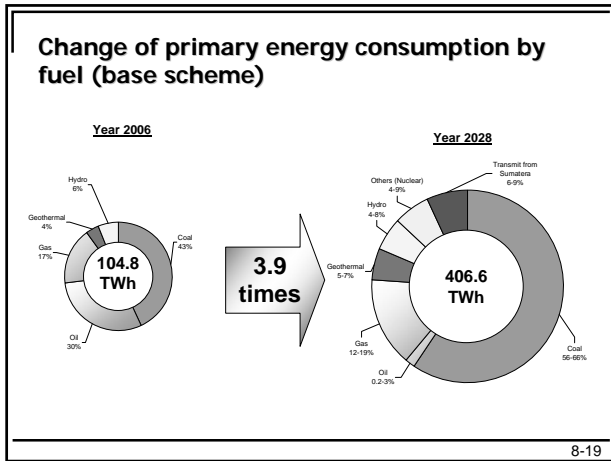

### Power development target (2028) for Base scheme

Scenario	Sources	Oil	Coal	Gas	Geo-thermal	Hydro	Pumped storage	Nuclear	Renew-able
Present 2006	Capacity rate 2006(%)	29	39	17	3.5	11.5	0	0	0
	Energy rate 2006 (%)	30.4	43.2	3.7	3.7	5.9	0	0	0
Base Scheme		Energy rate 0.2 % due to PLN target.	Energy rate 56-66 % due to policy.	Energy rate 12 % due to policy and on-going projects.	Energy rate 5 % due to policy and feasible capacity.	Energy rate 4-8 % due to policy.	Due capacity developed for peak according to WASP.	Capacity rate 5-7 % 4-5 GW due to roadmap.	Negligible.

8-21

### Power development target (2028) in Scheme 1: lower generation cost (Priority to coal)

Sources	Oil	Coal	Gas	Geo-thermal	Hydro	Pumped storage	nuclear	Renew-able
Target	Energy rate 0.2 % due to PLN target.	Energy rate 70 % because of cheap fuel. <b>Positively developed.</b>	Capacity rate 10 % because of expensive fuel. <b>Not positive.</b>	Capacity 1,620 MW, 2% added with <b>feasible 785 MW.</b>	Energy rate down to 2 % due to high initial cost. <b>Not positive.</b>	Due capacity developed for peak according to WASP.	Capacity up to 5 GW (7%) due to cheap production cost.	<b>Negligible</b> due to expensive production cost.

8-22

### Power development target (2028) in Scheme 2: Reliable and stable power supply system

Sources	Oil	coal	Gas	Geo-thermal	hydro	Pumped storage	nuclear	Renew-able
Target	Energy rate 2-3 % to keep a source.	<b>Cover power shortage.</b>	Energy rate 19 %, <b>positively developed using LNG</b>	Available capacity 3.6 GW, 5 %, <b>positively developed.</b>	Energy rate 4-8 %, <b>storage type developed.</b>	Due capacity developed for peak according to WASP.	Capacity 5 GW (7%) to diversify sources.	Energy rate 4 %, solar, wind and biomass, <b>to diversify sources.</b>

8-23

### Power development target (2028) in Scheme 3: Less global environmental impact

Sources	Oil	coal	Gas	Geo-thermal	hydro	Pumped storage	nuclear	Renew-able
Target	Energy rate 2-3 % to keep a source.	Cover shortage, at least 18 % capacity after FTP.	Energy rate 19 %, <b>positively developed using LNG.</b>	Available capacity 3.6 GW, 5 %, <b>positively developed.</b>	Energy rate 4-8 %, <b>to be developed.</b>	Due capacity developed for peak according to WASP.	Capacity 5 GW (7%) to reduce CO <sub>2</sub> emission.	<b>Energy rate 5 % by solar and wind, and 2 % by biomass.</b>

8-24

## 8. Power Development Scenario

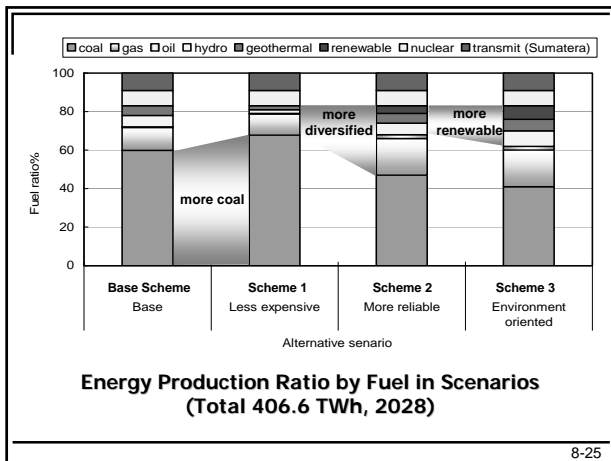

### 4. Suggestion for Follow-up Project

- ◆ gas storage; LNG or CNG,
  - ◆ infrastructure to procure coal,
  - ◆ hydropower plants including pumped storage,
  - ◆ Java-Kalimantan interconnection,
  - ◆ direct current transmission line project in Jamali region.
- 8-26