

南アフリカ共和国  
南アフリカ国農業省  
リンポポ農業局

南アフリカ共和国  
リンポポ州スククネ郡スクノード地域  
農村総合開発計画調査 最終報告書

別冊

平成19年3月  
(2007年)

独立行政法人  
国際協力機構 (JICA)

アイ・シー・ネット株式会社  
太陽コンサルタンツ株式会社

農村

JR

07 - 19

## 別冊の内容

1. パン焼きビジネスモデルの提案書
2. 「実践農家訓練プロジェクト」研修運営ガイドライン
3. 一反複合農業技術マニュアル集
4. 参加型土壌保全実施ガイドライン・メンテナンスマニュアル
5. センターオブエクセレンス・プロジェクト（CEP）のワークブレイクダウン  
ストラクチャー（WBS）
6. C D
  - 報告書一式電子ファイル
  - パイロットプロジェクト紹介ビデオ（2007年改訂版）

## 1 . パン焼きビジネスモデルの提案書

# Proposal on standard business plan of village bakery

## 1. INTRODUCTION

PRIDE in Sekhukhune (PRIDE), a rural development project in Sekhukhune District implemented by Limpopo Department of Agriculture (LDA) with a support from Japan International Cooperation Agency, has conducted a pilot project of “Women business Promotion.” Main purpose of this pilot project is to establish an appropriate model of small and micro enterprise in a context of the poverty situations.

This bakery project has following uniqueness:

- 1) Home-made style product of this bakery has a comparative advantage over existing bread produced by large commercial bakery companies;
- 2) This bakery introduces a “traditional production method” using a mad or a brick oven, ordinal flour, ordinal yeast, and fire wood. This enables a product to have a unique characteristic, and ordinal poor residents to start this business with a low initial and low running cost. At the same time, this low-tech baking method is easy for poor residents to learn and manage;
- 3) Main market of the product is local markets, including sale at pension-pay-points, neighboring schools and so on.
- 4) Combined the unique characteristic of the product, the low initial and recurrent const, and the exploration of local market, this business model has a low risk of failure, and is easily adopted by less experienced residents in rural areas.

Based on the experience of this pilot project, PRIDE team has a reasonable confidence that this business model is effective for rural development and poverty alleviation in the province. However, due to the limitation of administrative jurisdiction of LDA, continuation of expansion and promotion of this business model will not be covered by activities of LDA after the completion of PRIDE.

PRIDE team has been looking for any institutions, which would be suitable for taking over of the promotion of this business model, and expected Department of Health and Welfare (DHW) might be the one. Accordingly, PRIDE team has prepared this proposal to DHW to seek for a possibility of continuous support for promotion of this village bakery business.

## 2. VILLAGE BAKERY BUSINESS MODEL

### (1) Target population

Community groups of about five (5) people are appropriate.

### (2) Initial input

Items	Detail	Input items	Amount	Expenditure
Basic infrastructure	One brick oven	Brick	100	R100 = R1/piece x 100 pieces
		Cement	1 bag	R55 = R55/bag x 1bag/50kg
		Colgate iron	2 plates	R100 = R50/plate x 2 plates
		Labor		By the group
	Roof over the ovens	Colgate iron Poles, etc	1 set	R1,500
	Bread pans	Pan	30	R600 = R20/piece x 30 pieces
	Dish for mixing	Dish	1	R100 = R100/dish
	Packaging bags	Plastic bag	1 pack	R30 = R30/1,000 bags
Other input to start production	Ingredients for first 300 loaves (30 loaves/time x 10 times)	Flour	10 bags (1bag/time)	R500 =R50/12.5kg x 1bag x 10times
		Yeast	40 bags (4bags/time)	R80 = R2/10g x 4 bags x 10times
		Vegetable oil	1 bottle (2 L)	R20 = R20/2L x 1 bottle
		Sugar	1 bag	R60=R60/12.5kg x 1bag
		Salt	15 bag	R15 = R5/1kg x 3 bags
		Margarine	2,500 g (250g/time)	R50 = R10/500g x 5 pieces
	Fuel	Fire wood		Collected by the group
Total Initial Input				R3,210

### **(3) Production**

With two brick ovens and enough amounts of ingredients, a group can bake up to 60 loaves of bread a day. On top of this, groups may be able to diversify their products including buns and donuts.

### **(4) Marketing**

Sale of the product can be started from direct selling in the village. Main expected consumer of bread is house wives in the village, and that of buns and donuts are school students. Once a group gains a good reputation on their product, they may be able to secure regular customers.

Next possibility is selling at pension-pay-points. In order to make this sale possible, group should be confident that their product is enough both for sale at the village and pension-pay-points.

Further possibility is contract supply of bread to neighboring schools and hospitals. This is an advanced level, and a group should have enough management skill for procurement, production, quality control, accounting, and have knowledge on business contract.

### **(5) Sale and Benefit**

Price of one loaf of bread should be determined according to existing price range of commercial bread in the area in order to maintain competitiveness. According to the experience of PRIDE, price of a loaf is R3.20, and gross benefit out of one loaf is about R1.20. Assuming a group produces 60 loaves a day for 25 days a month, they earn gross benefit of R72.00 per day, or R1,800.00 per month. Given a group consists of 5 members, monthly income for one person is R360.00. As a precondition to gain this net benefit, the group has to accumulate about R3,000.00 for procurement of ingredients for next month, therefore, a group may have to wait for two (2) months to actually gain the net benefit.

### **(6) Preparation for Future Needs of Fire Wood**

Main fuel of this bakery business is fire wood. A bakery group collects free access fire wood from its surrounding area. This has two difficulties including 1) possible environmental destruction, and 2) shortage of fuel wood once production increases. As a precaution to these problems, bakery group should be strongly recommended to plant trees around their premise. Tree seedlings may be included in the initial input support

from the government, however, considering ownership and responsibility of seedling care, it is more recommendable that the government should only facilitate discussions on the necessity of plantation among a group, and tree seedlings should be paid by a group.

### **3. NECESSARY SUPPORT FROM THE GOVERNMENT**

This section explains necessary external support to make the village bakery business successful. Standardized schedule of external support in accordance with development of business development by a bakery group is attached as Attachment 1 and 2.

#### **(1) Financial Assistance**

One of critical lessons learnt from the experience of PRIDE is that external support including financial support should be given to target groups in a small scale and continual manner, rather than a large scale one-shot manner. Usually poor residents do not have experience of handling a large amount of money in their past, and giving a large amount of money often results in creating a suspicious atmosphere among a group, and sometimes actual miss-management of the money. Initial stage of business development is a very sensitive period for a group to build a trust among members, gaining confidence on their capability of production and business management. Therefore, external support should be very much careful so that any interventions will not create any negative impact to the group.

Consequently, in order to support this business model, PRIDE team recommend that financial support should be given to a group bit by bit according to development of the group's skill and confidence on the business.

#### **(2) Technical Assistance**

On top of the financial assistance, following technical support are indispensable to secure a success of the promotion of the village bakery business.

##### **1) Group Formation**

If a target group is newly established for a purpose of starting this bakery business, formation of a group should be guided by external support. Selection of chairperson and other necessary positions should be properly done, a constitution should be prepared, and work/responsibility of the members should be clearly defined. Extension officers of

DHW may be able to assist this.

## **2) Technical Training on Oven Construction and Bread Baking**

Once a group is ready, they should be trained on how to build ovens and how to bake bread. Existing bakery groups, which participated in PRIDE, are capable of providing this training. Therefore, extension officers of DHW may be able to organize a training sessions for the new groups together with the existing bakery groups. List of the existing bakery groups participated in PRIDE is attached as Attachment 3.

## **3) Accounting and Basic Financial Management**

Sometime after a new group started producing bread, supplemental training especially on accounting and on basics of financial management should be provided. This kind of training may be organized by collaboration with Department of Labor.

## **4) Diversification of Product**

Once a new group is capable of managing daily production of bread, they may be interested in producing other baking products. Once again, some the existing bakery groups participated in PRIDE have already producing other products than bread successfully, and they are capable of providing technical training. Extension officers of DHW may be able to organize, based on request from the new groups, training sessions for diversification of their products.

## **5) Mediation for Group Management**

Another lessons learnt from PRIDE experience is that most common reason of collapse of a business is not an economical failure, but difficulties in group management. Therefore, continual external support to mediate conflicts within a group is crucial for a success. It is recommendable that extension officer of DWH should keep this in mind during their intervention to groups.



**Attachment 1: Standard of Business Development and Necessary External Support**

Time	Process	Activity	Input	Profit
1 1 <sup>st</sup> week	Group forming	<ul style="list-style-type: none"> <li>- Collect the members, and form the committee</li> <li>- Appoint the positions of the committee (chairperson, secretary, treasurer)</li> <li>- Draw the group's constitution</li> </ul>	Monitoring	NA
2 2 <sup>nd</sup> week	Orientation	<ul style="list-style-type: none"> <li>- Discuss the future activities among the group</li> <li>- Invite the dept of health to the discussion</li> <li>- Form the consensus among the group</li> </ul>	Monitoring	NA
3 3 <sup>rd</sup> week	Workshop	<ul style="list-style-type: none"> <li>- Attend the Bread baking workshop</li> <li>- Learn how to construct mud oven</li> <li>- Learn how to bake the bread</li> <li>- Share and confirm the lessons among the group</li> </ul>	Transportation cost (Arrange hiring the taxi)	NA
4 4 <sup>th</sup> week	Planning	<ul style="list-style-type: none"> <li>- Draw the annual schedule of the activities</li> <li>- Find the supplier of the ingredients and baking pans</li> <li>- Allocate the responsibility to each member</li> <li>- Make the marketing plan of the bread</li> <li>- Collect the jointing fee from each members</li> <li>- Open the account for the group</li> </ul>	Monitoring	NA

5 2 <sup>nd</sup> month 1 <sup>st</sup> – 2 <sup>nd</sup> week	Oven making	<ul style="list-style-type: none"> <li>- Collect the cow dung and making the heap</li> <li>- Collect the cardboard paper for covering</li> <li>- Plaster the heap using the mud mixed by the water and cardboard paper</li> <li>- Burn the plastered mud oven</li> </ul>	Monitoring	NA
6	Oven trial	<ul style="list-style-type: none"> <li>- Collect the firewood</li> <li>- Burn the firewood inside the mud oven</li> </ul>	Monitoring	NA
7	Procurement of the ingredients	<ul style="list-style-type: none"> <li>- Purchase the ingredients for bread (Flour, sugar, yeast, salt, sunflower oil, etc)</li> <li>- Purchase the baking pans according to the plan</li> </ul>	Cost for ingredients (R2,000) Cost for baking pans	NA
8 2 <sup>nd</sup> month 3 <sup>rd</sup> -4 <sup>th</sup> week	Bread Baking trail	<ul style="list-style-type: none"> <li>- Prepare the dough and bake the bread according to the recipe</li> <li>- Learn the adjustment of the fire and baking time</li> <li>- Repeat the trial until it keep on good result</li> </ul>	Monitoring	NA
9	Marketing	<ul style="list-style-type: none"> <li>- Door to door campaign</li> <li>- Market the people's gathering point</li> <li>- Promote the sales at pension pay point</li> </ul>	Monitoring Adviseing	R2.0 per loaf → 30 loaves / day → R60 / day → R1,800 / month
10 3 <sup>rd</sup> month	Carry out the activities	<ul style="list-style-type: none"> <li>- Set up the each member's responsibility</li> <li>- Repeat the daily activities and try to expand the marketing</li> </ul>	Monitoring	

11	Storming	<ul style="list-style-type: none"> <li>- Hesitant members will drop out</li> <li>- The surviving members will continue the activities</li> <li>- Try to solve the problems</li> </ul>	Monitoring (Less advising)	
12	Norming	<ul style="list-style-type: none"> <li>- The surviving members agree on procedures and rules within group to limit problems</li> <li>- Carry out the activities</li> </ul>	Monitoring Advising	
13	Performing	<ul style="list-style-type: none"> <li>- Expand the door to door campaign</li> <li>- Try to negotiate with the school nearby for supplying the bread to the lunch scheme</li> <li>- Construct the roof over the oven against rain</li> </ul>	Cost for roof	R2.0 per loaf → 60 loaves / day → R120 / day → R3,600 / month
14	Enhancing (Skill development)	<ul style="list-style-type: none"> <li>- Develop the necessary skill for expansion (Bookkeeping, marketing, new techniques, new product rather than bread, etc)</li> <li>- Suggest to construct the second mud oven, purchase the additional baking pans to increase the production</li> </ul>	Training Cost for additional baking pans	

## **Attachment 2: Tips for External Assistance**

### **1. Group forming**

- Advertise its assistance to the small-scale business, and collect the application
- Identify the potential group
- Join the group meeting and guide them to appoint the positions and draw the constitution (defining the responsibility of the each member)

### **2. Orientation**

- Guide the group discussion (Not taking over the leadership)

### **3. Workshop**

- Assist the group to arrange the transportation to join the workshop in the distance

### **4. Planning**

### **5. Oven making**

### **6. Oven trial**

- Guide the group discussion (Not taking over the leadership)

### **7. Procurement of the ingredients and baking pans**

- Not providing the money, but arranging the procurement with the shops together with the group members, and share the information of the procurement

### **8. Bread Baking trials**

### **9. Marketing**

### **10. Carry out the activities**

- Provide the advise if needed, but limit intervention to suggestion the idea for production, marketing, and accounting (not aggressively promoting or financially rewarding)

### **11. Storming**

- keep away and don't have to persuade hesitant members to remain or to resolve outstanding issues for the group. It is up to them, and it is better to allow a group to fail at this stage, than 'artificially' to keep it alive so that it fails later when far more is at stake.

## **12. Norming**

- can help with advice on procedures, responsibilities and regulation. The outsiders must only advise and not take over, but he can offer valuable advice at this stage, when the group is ready to regularize its affairs.

## **13. Performing**

- Once a group is performing, it should be strong enough to make use of outside assistance without being taking over. The '11. Storming' may be necessary for the establishment of a strong group.

## **14. Enhancing the group capability**

- Assist the group to develop them further by providing them with the opportunity to attend the training in production techniques, marketing, accounting, group management, advertisement etc. Type of the training should be decided based on the request from the group, but suggestions from outsiders also can be appreciated.

**Attachment 3: Standard Production Procedure (From Bakery Demonstration Workshop on December 15th, 2005, at Ga-Nnchabeleng)**

1. Boil 9 liters of water.
2. Put 12.5kg flour into a dish. Add 250g margarine and mix them together.
3. Add 2 handful sugar, 1 handful salt, 40g yeast.
4. Mix them together .
5. Mix boiled water with cold water.
6. Add water to the dry ingredients.



7. Wash 2 buckets (20 liter size). Rinse the buckets with warm water.
8. Divide the dough into 2 buckets. Put lids on the buckets, cover with maize bags and keep them in warm place.



9. When the dough raises, mix the dough so it goes down. When the dough raises again, mix the dough again.
10. When the dough rises for the third time, put the dough into baking pans. Cover the baking pans with maize bags. Let the dough to rise in the baking pan.

11. Prepare fire in the oven
12. Wait for dough to raise
13. Adjust fire in the oven
14. Put bread in oven
15. Check the bread after 15 minutes.

Check the bread again after another 15 minutes.

16. After taking the bread out of the oven, put bread on maize bag for cooling.



## 2 . 「 実 践 農 家 訓 練 プ ロ ジ ェ ク ト 」 研 修 運 営 ガ イ ド ラ イ ン

**Guideline Manual**  
**for Practical Farmer Training Project**



**PRIDE in Sekhukhune**  
*Japan International Cooperation Agency (JICA)*  
*and Limpopo Province Department of Agriculture*

2005-2006





## ? What is Practical Farmer Training Project

Practical Farmer Training (PFT) Project aims to train young people in agriculture. A new method of training is established to foster keen interest in agriculture among youth. PFT Project puts emphasis on youth who are likely to become emerging farmers. It also stresses the basic concepts of learn-by-doing and farmer-to-farmer experience sharing.

## ? What is the difference between PFT Project and past training projects

Most of the past agricultural training courses were conducted either in colleges or experimental farms where conditions are different from what is happening on real farms. In PFT Project, the youth will be first trained by mentor farmers on their farm. The mentors are practicing relatively advanced farming, and have substantial experiences in farming already. Advantages of training by mentor farmer are that youth can be inspired through training by a farmer in their own community and they have opportunity to experience real challenges and effort required for farming.

## ? What are trainees going to do in the Project

The trainees of PFT Project will first attend on-farm training at selected mentor farmer's. The on-farm training will commence in August and end in January of following year. After getting practical experiences on farm, some selected trainees will then attend a vegetable production course at agricultural college from February to May. A study tour will also be conducted, an opportunity for the trainees to meet other emerging farmers and learn more about farming methods and commercial farming.

## ? How to implement the Project

### **Plan of operation for PFT Project**

Plan of operation for PFT Project along with its annual schedule are also shown in Annexure 1.

1. **Hold orientation session for technicians** to explain about PFT Project, to designate responsibilities and confirm schedules for the Project.

## 2. Identification of mentor farmers

a. *Locate potential mentor farmers* with agricultural technicians.

b. *Make a list of potential mentor farmers with characteristics* of each mentor farms. Consider some of the followings:

- Size of the farming land
- Source of water
- Available facilities (pump, tractor and so on)
- Crops being cultivated and use of agrochemicals.
- Number of years the farmer has been practicing agriculture
- Location



c. *Select mentor farmers* based on the list and discussion among technicians and project manager.

### ***Practical Words 1:***

Mentor farmers are expected to train the youth as well as to give young people inspiration and to orient them in farming career. Hence, mentor farmers should not be just anybody practicing farming but someone who have substantial experience in farming and agricultural businesses.

d. *Discuss with selected mentor farmers* about PFT Project and rewards given to mentor farmers. Also discuss with mentor farmers the content of the training. Some of the mentor farmers may have never taught agriculture to others and are worried about what they have to teach and how they have to teach. Agree on the first day of training.

e. *Sign agreement* with mentor farmers for participating in the Project.

## 3. Selection of trainees

a. *Establish selection criteria.*

The example of selection criteria:

- Minimum age of 18



- Access to land to practice farming after the completion of the training
  - Strong interest in agriculture
  - Must be able to commute on their own to farm of the mentor farmer
  - Agree to the conditions that no wage will be paid and no lunch will be provided
- b. ***Inform the communities/tribal authorities*** where the PFT Project will take place.

***Practical Words 2:***

In 2004-2005, one of the mentor farmers was connected with a local agricultural cooperative. The cooperative sent some of their young members for the training. Partnership with local organization is one option to find potential trainees. The advantage of working with local organizations is that trainees have backup support from the organization they belong.

- c. ***Make advertisement material*** for calling application from the interested youth. The advertisement must include information on:
- Project information (Location, duration etc)
  - Eligibility
  - How to apply
  - Location and date of interview
- d. ***Advertise*** the programme and call for application. Use word-of-mouth through agricultural technicians, post advertisement in tribal offices and community centers, and use Mobile Information Unit.
- e. ***Develop interview sheets***. During the interview, confirm that the candidates are meeting the selection criteria. Refer to Annexure 2 for a sample of interview sheet.
- f. ***Conduct interviews***.
- g. ***Select trainees*** using the result of interviews.
- h. ***Inform selected trainees***. Inform them also the date and time of first training.
- i. ***Sign agreement*** with trainees about their participation in the Project as well as their responsibilities.

#### 4. On-farm training

- a. *Conduct on-farm training.*
- b. *Monitor on-farm training.* Check the attendants of each trainees, monitor their progress and commitment to agriculture.



#### 5. Study tour

- a. *Select date and place* for a study tour. Ideally, the tour should take place within the District and last for only one day. Consider why you want to take them to the particular place and its relevance to their training.
- b. *Make arrangements* for the study tour. Transportation, picking up trainees, programme and lunch.
- c. *Conduct study tour.*

#### 6. Training at agricultural college

- a. *Discuss with Tompi Seleka* agricultural college about short-term vegetable course. Determine how many trainees from PFT Project they can accept.
- b. If necessary, make selection for trainees going to Tompi Seleka.
- c. *Inform trainees about course* at Tompi Seleka.
  - Duration of the training
  - Things to bring (toiletry, bedding, eating utensils)
- d. *Make arrangements* for transporting trainees between their village and Tompi Seleka.
- e. *Training at Tompi Seleka* Agricultural College.
- f. *Monitor the training* at Tompi Seleka.



#### 7. Closing ceremony

- a. *Determine the date and place* for closing ceremony.
- b. *Print certificate* to award trainees for completing the trainings as

well as to appreciate mentor farmers who have provided on-farm training for the trainees. For the example of certificates refer to Annexure 3.

- c. *Inform trainees and mentor farmers* about the ceremony and transportation arrangement.
- d. *Conduct closing ceremony.*



#### **8. Evaluation of the Project**

- a. *Develop evaluation questionnaire* for both mentor farmers and trainees who participated in the Project.
- b. *Distribute the questionnaire* and ask mentor farmers and trainees to fill the forms. Responses on the questionnaire will help the Project improve its operation following year. See Annexure 4 and 5 for questionnaires used for the evaluation of PFT Project 2004-2005.

### **Beyond just implementing the Project**



#### **What do we have to do for the trainees and mentor farmers**

*After-care for the trainees:* Although the Project only trains interested youth in on-farm training and in vegetable production course, it is important to address the trainees concerns regarding their plans after the Project. Many youths are not sure how to start farming because of limited available resources. After PFT Project 2004-2005, some of the former trainees were interviewed and selected for PRIDE in Sekhukhune's another project, 0.1ha Integrated Farming Project where the farmers supported by PRIDE practice small-scale integrated farming. Tying up the former trainees with existing projects is one of the ways to help the former trainees. Kinds of assistance and programmes available through LDA should be explained to the trainees.

*Reward for the mentor farmers:* Mentor farmers who provide on-farm training to the youth are not paid for their effort. However, other means of rewarding their effort should be taken into consideration. In 2004-2005, the project implementation body considered followings as reward for the

mentor farmers:

- Agricultural hotline: Direct technical support from LDA District Office to the mentor farmers and needs-oriented training course at Tompi Seleka Agricultural College.
- Issuing certificate of “advanced farmers”: Issue special certificate from LDA to officially recognize the mentor farmers’ advancement in agriculture business.
- Better loan conditions from Land Bank: To provide favorable conditions for small scale loan.



*“I want to supply my community with vegetables. Agriculture is our future.”*

Trainee



This manual was prepared as part of the PRIDE in Sekhukhune's Practical Farmer Training Project to assist agricultural technicians, communities and other stakeholders in implementing the Project. The manual provides guidelines for implementing the Project with the hope that it will help improve the Project.



*For Contact and information*

Sekhukhune District  
Department of Agriculture  
Private Bag X01  
Chuenespoort  
Tel: 015 632 4147  
Fax: 015 632 4387









### Monitoring Sheet for Practical Farmer Training Project

Phase	Activities	Last date	Responsible person(s)	Person to report to	Finished date	Remarks
	Information session is conducted	1-Jul	Project Manager			
Selection of mentor farmers	List of mentor farmer with their characteristics is submitted	15-Jul	Technicians	Project Manager		
	Names of selected mentor farmer is given to Sub-District	20-Jul	Project Manager	Sub-District Managers		
	Scientist visited each mentor farmer and designed on-farm training	26-Aug	Scientist	Project Manager		
	Agreements signed by mentor farmers	26-Aug	Technicians	Project Manager		
Selection of trainees	Criteria and interview date are established at information session	1-Jul	Project Manager			
	Selected communities are informed about Project	27-Jul	Technicians	Sub-District Managers		
	Advertisement is printed and given to MIU and technicians	27-Jul	Project Manager			
	Advertising for the training	10-Aug	Technicians, MIU	Project Manager		
	Interview sheets are developed	27-Jul	Project Manager			
	Interviews conducted	17-Aug	Technicians	Project Manager		
	Trainees are selected	19-Aug	Technicians	Project Manager		
	Interview sheets and results submitted	19-Aug	Technicians	Project Manager		
	Successful candidates are informed	26-Aug	Technicians			
	Agreements signed by selected trainees	26-Aug	Technicians	Project Manager		
On-Farm training	Inform first day of training	26-Aug	Technicians			
	On-farm training takes place	13-Jan	Mentor Farmers			
	Training is monitored	13-Jan	Mentor Farmers	Technicians		

Study tour	People at study tour site is informed	30-Nov	Project Manager			
	Date and time is agreed	15-Dec	Project Manager	Sub-District Managers		
	Transportation and lunch are arranged	20-Jan	Project Manager			
	Trainees are informed	13-Jan	Technicians	Project Manager		
	Conduct study tour	27-Jan	Project Manager			
Training at agricultural college	Arrangement for short-term course is discussed with Tompi Seleka	15-Dec	Project Manager			
	Trainees are selected	13-Jan	Mentor Farmers	Technicians		
	Trainees are informed	13-Jan	Technicians			
	Transportation is arranged	27-Jan	Project Manager			
	Training at agricultural college takes place	Beginning Feb	Tompi Seleka			
	Training is monitored	Apr	Tompi Seleka	Project Manager		
Closing ceremony	Date and venue for closing ceremony is selected	7-Apr	Project Manager			
	Certificates are printed	7-Apr	Project Manager			
	Trainees and mentor farmers are informed	28-Apr	Technicians			
	Closing ceremony is conducted	26-May	Project Manager			
	Project evaluation	May	Project Manager			

**Interview Sheet for PFT Candidates**

Name of the trainee : .....  
Place : ..... Venue : .....  
Date : ..... Time : .....

Question 1: Explain in short why are you interested in this program?

Question 2: According to you why are most youth not interested in agriculture?

Question 3: Do you have a piece of land where you can practice farming, or can someone close to you give you one?

Question 4: Give three criteria mentioned in the advertisement letter.

Question 5: Why do you think is necessary for you to abide by the stipulated criteria on the advertisement letter?

Question 6: Do you have experience on crop, fruit or vegetable production?

Question 7: May you please tell us what you know about one of the three mentioned areas above?

Question 8: If you can be given this opportunity to be one of the selected trainees, what will you do to make this program a success?

Question 9: What should the department do to you if they invest money in training you, and you decided not to go on with the program?

Question 10: According to you what should the department do to make this program a success?

Question 11: When do you think you can start with this program if selected?

Total score:..... Name of the interviewer.....

**CERTIFICATE  
OF  
APPRECIATION**

May 2005

*This is to certify that Mr./Ms.....  
..... has given on-farm training for youth  
trainees selected by Limpopo Province Department of Agriculture and Japan  
International Cooperation Agency as a mentor farmer. This is part of the Pilot  
Projects on Participatory Rural Integrated Development - "PRIDE in  
SEKHUKHUNE," a collaborative project of Government of South Africa and  
Government of Japan.*

For Japan International  
Cooperation Agency

For Limpopo Province  
Department of Agriculture



**CERTIFICATE  
OF  
COMPELTION**

May 2005

*This is to certify that Mr./Ms.....  
..... has successfully completed on-farm  
training as an youth trainee selected by Limpopo Province Department of  
Agriculture and Japan International Cooperation Agency under the supervision  
of a mentor farmer. This is part of the Pilot Projects on Participatory Rural  
Integrated Development - "PRIDE in SEKHUKHUNE," a collaborative project  
of Government of South Africa and Government of Japan.*

For Japan International  
Cooperation Agency

For Limpopo Province  
Department of Agriculture



**PRIDE in Sekhukhune  
Practical Farmer Training Project 2004-2005**

Trainees Feedback Questionnaire

Please answer following questions to help us improve the Project in the future. Any additional comments and suggestions are appreciated.

1. Was on-farm training with mentor farmer helpful? Yes / No / Maybe

2. How would you rate your mentor farmer?

Excellent      Good      Bad      Don't know

3. Was vegetable production course at Tompi Seleka College of Agriculture helpful? Yes / No / Maybe

4. Would you like to continue agriculture after this Project? Yes / No

If yes, please tell us your plans.

5. In your opinion, what can we do to improve the Project in the future?

**PRIDE in Sekhukhune  
Practical Farmer Training Project 2004-2005**

Mentor Farmers Feedback Questionnaire

Please answer following questions to help us improve the Project in the future. Any additional comments and suggestions are appreciated.

Name: .....

1. Do you think that the number of trainees attended training on your farm was appropriate?

Yes / Could be more / Could be less

2. Do you think it was appropriate season to conduct on-farm training?

Yes / No

3. Do you think the trainees are now capable of farming on their own?

4.

Yes / No

5. What would you improve if you are training the youth again?

6. Would you train the youth as part of the Project again? Yes / No

If no, please explain why?

If yes, what kind of assistance do you expect from LDA?

### 3 . 一反複合農業技術マニュアル集



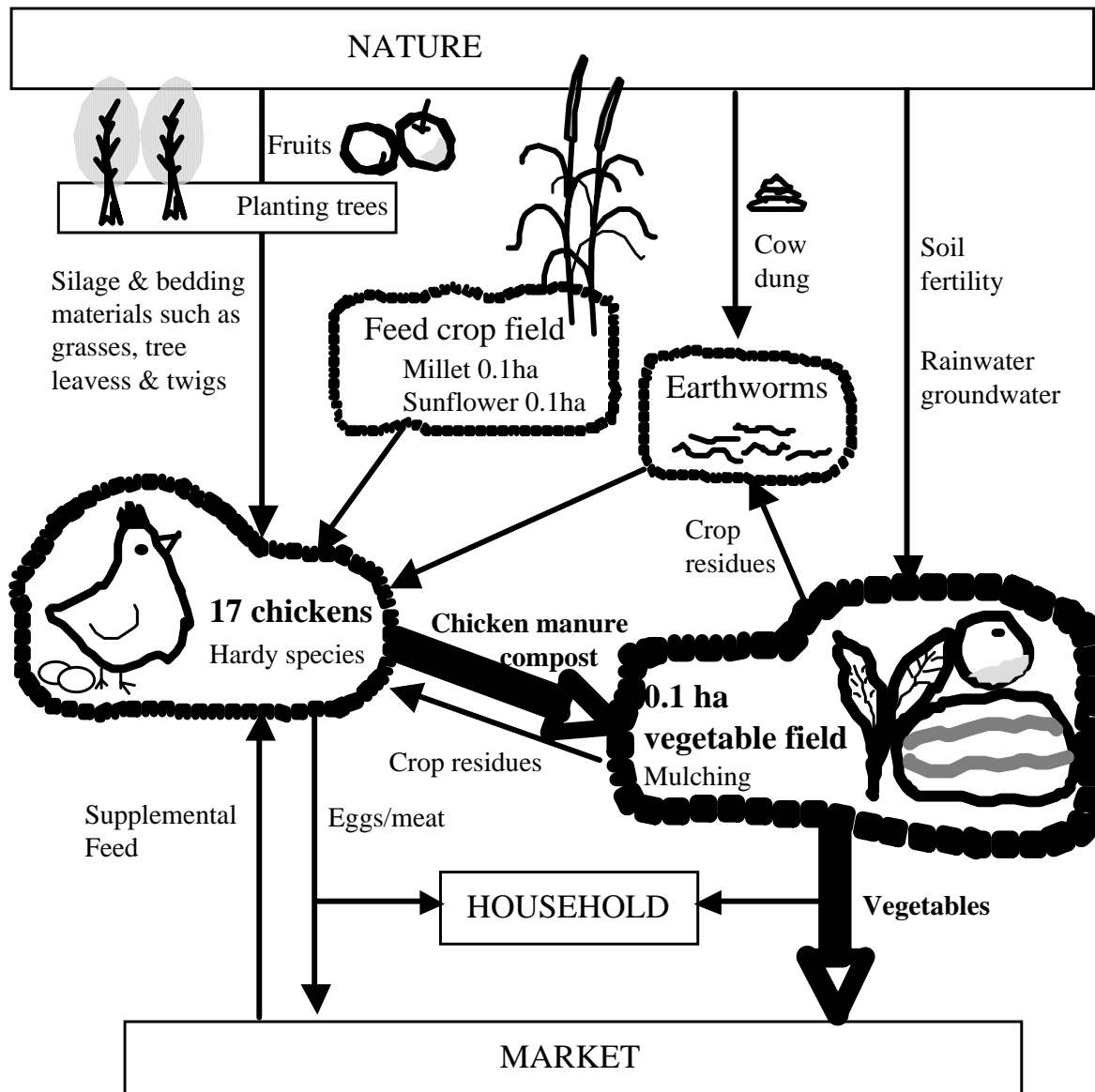

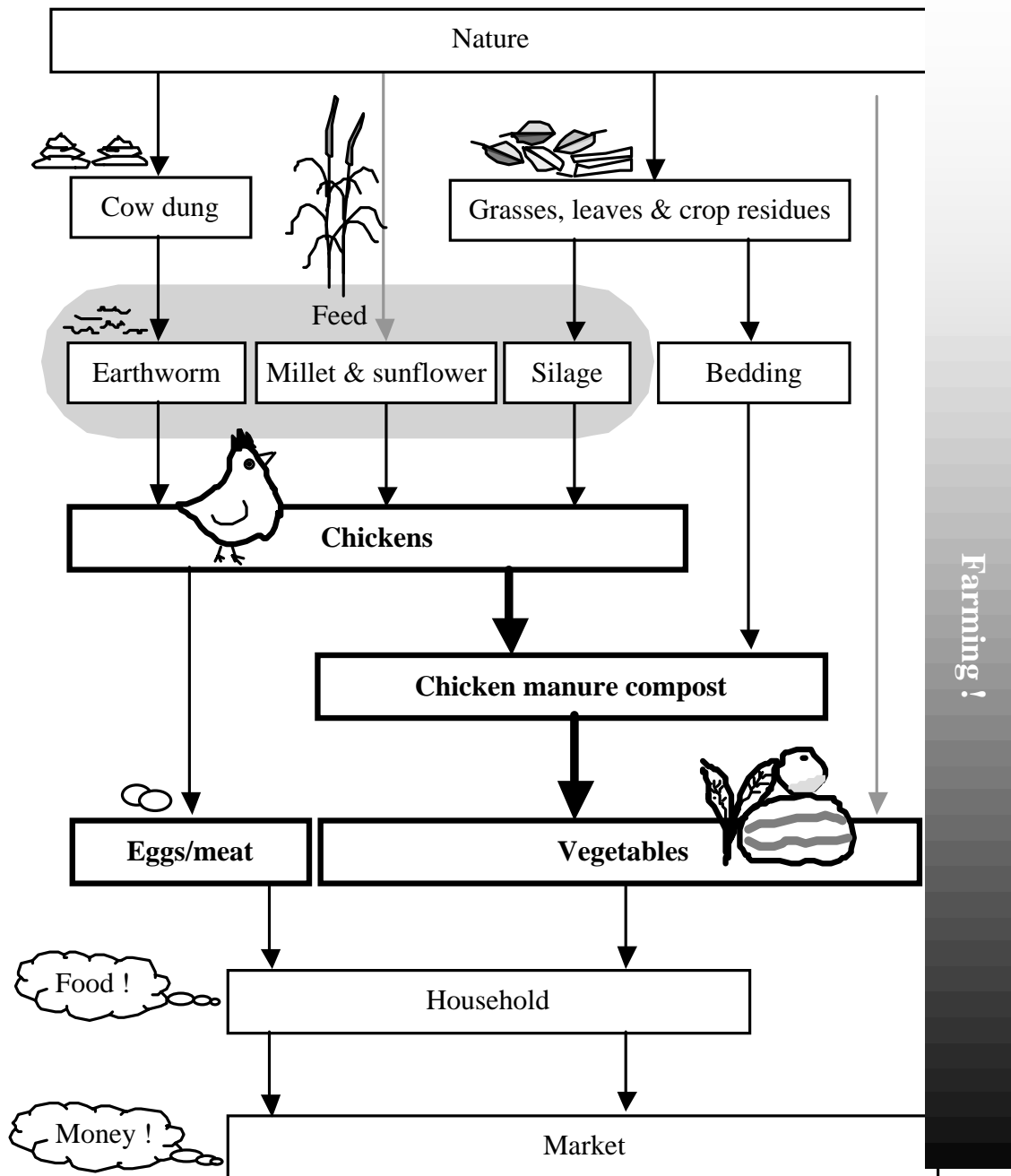

**Farming is the process of converting "cow dung" into "food & money."**

**Upper components provide "nutrients" for lower components.**

## Silage Production

ver. 3

1. Feed for indigenous chicken should be made on your own. Purchased feed is expensive. You may lose money if you buy daily feed from outside.
2. What is available around your field? Unused grasses in rainy season can be utilized as chicken feed. It contains carbohydrate, vitamins and minerals. You may need to plant some grasses. Some leguminous plants contain much nitrogen. The point is that those grasses are available only in rainy season. In dry season, you have to use preserved grasses.
3. Ensilaging is a method to preserve grasses for a long time. Lactic acid bacteria fermentation makes raw grasses into silage, which lasts more than a year **under anaerobic condition**.
4. Cut fresh grasses and fresh crop leaves into 10 cm length. Pack them into a drum (200kg). Standing on the top of the grasses and using your weight, push them well and pack them again and again. Lastly put a flat board on the top of the packed grasses (within the drum, not on the drum) and put heavy stone on it. The day after, packed grasses goes down. Pack grasses again. Put the flat board and stones again, cover over the stone by plastic sheet and fix it with elastic bands to prevent rainwater, insects and animals from getting into it.
5. The most important tip to make good silage is to **push air out of the grasses completely**. If some air remains among grasses, undesirable microbes become active and grasses decay. When you push out air perfectly, sound lactic acid bacteria fermentation occurs and good quality silage can be produced.
6. After a month in summer and 2 months in winter, you can feed it to chicken. The surface of the silage in a drum will decay. Take it out (and feed for soil microbes in the fields) and use the next layer for chicken.

Grasses, leaves and crop residue

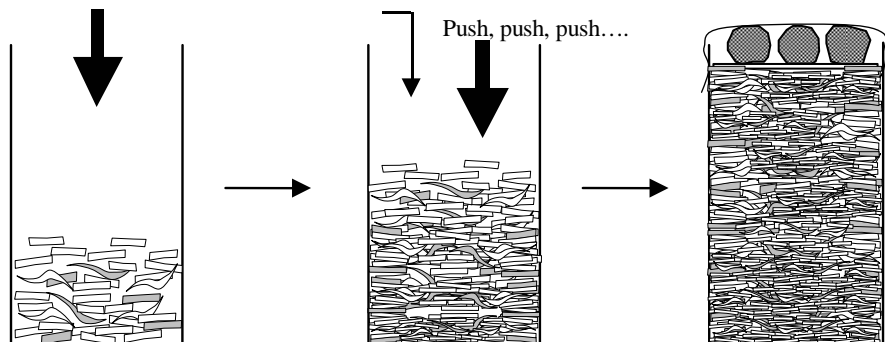

## Earthworm culture

Ver.3

1. **Construct shade**, as earthworms prefer cool, dark, breezing and quiet place. Measure 4 m by 3 m on the ground and stand 4 corner poles. Cover the top, sides and back with black shade net and fix it.
2. Place plastic sheet on the ground. Mix 2 wheelbarrows of soil and 1 bucket of 2 liter bucket of cow dung or goat manure. The ratio of kraal manure should be less than 7% because kraal manure often contains very high level of nitrogen. Apply water to 60-70% of moisture level. When you grab bed mixture tightly and release it, the mixture should be fixed but should be broken immediately if you touch it with your fingers. Put the mixture 0.5m by 1m and make a mound. The center will be 20 cm high. Put 1 tea cup (500g) of earthworms in it. Worms go down into the bed seeking water, darkness and feed if bed condition is good. Too low worm population density hinders sound reproduction. Cover the culture bed with shade net on the surface.

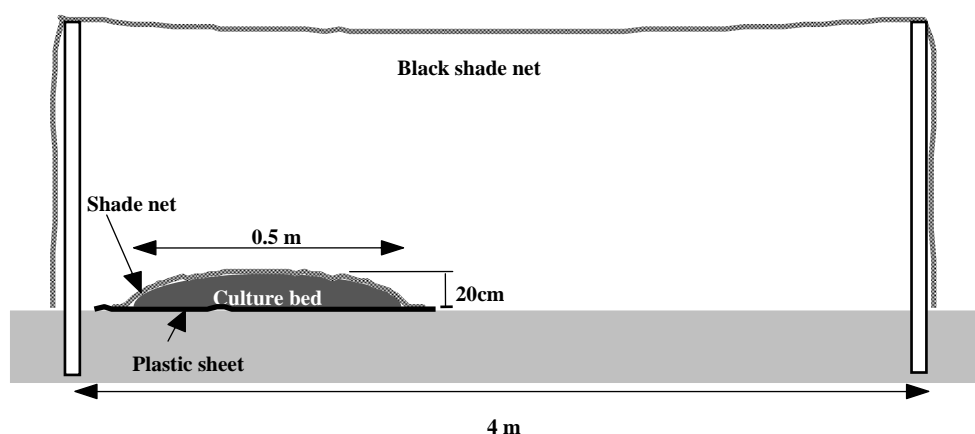

3. **Keep bed moisture level at 60-70%**. As soil is sandy and air is very dry, check the water level at least twice a week. Once a week, **plow by a hoe or a fork to keep aeration**. If earthworms are scattering evenly in the bed, their condition is OK.
4. Feed both plant-derived stuff such as vegetable and fruit residue and small amount of animal manure. **Once a week, feed 2-3 kg of plant derived stuff and 1/2 tea cup of cow dung or goat manure**. Mix the feedstuff with bed.
5. Worms grow and the part of 1/3 from the end of the body becomes swell and white. Eggs grow in it. New generation is born after 3-4 months from the introduction. When the second generation becomes big, population density will be too high. Remove half of the bed with worms into separate place. For each bed, add 1 wheelbarrows of soil with 1/2 bucket of 2 liter bucket cow dung or goat manure and shape 2 mounds.
6. Essential factors on earthworm culture are (1) medium temperature by shading (2) 60-70% moisture level of bed (3) aeration by plowing and (4) balanced and sufficient feed.

### Chicken shed construction

#### 1. Poles

- Measure 3 m by 2.5 m on the ground and make it flat.
- Dig 4 corner holes and a door hole of 30 cm in diameter and 40 cm deep.
- The interval of the door pole and the nearest corner pole should be 80 cm to allow a wheelbarrow to go through.
- Stand straight up 5 poles.
- Fill the holes up with cement and leave them a day.

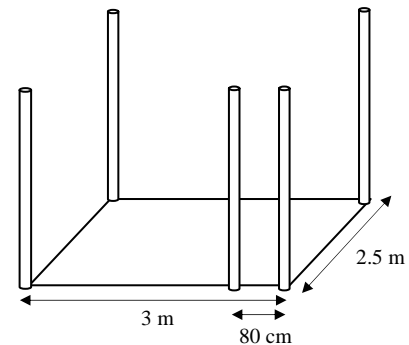

#### 2. Frame

- Bind the 5 poles with horizontal timbers.
- Fix a roof frame timber (3m long) at the center of 2.5 m sides.
- Make sure that three timbers (3 m long) are fixed in a slightly tilted line to make roof slightly tilted.

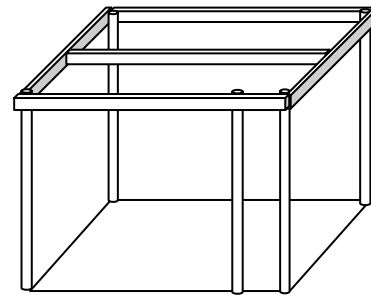

#### 3. Roof

- Fix corrugated irons on the roof frame with special nails.

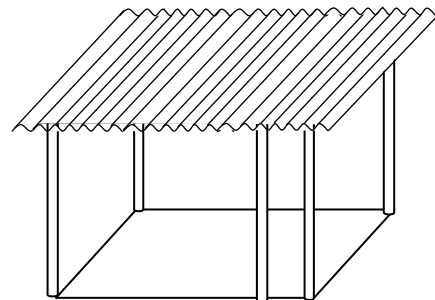

#### 4. Wall

- Make bricks with mixing soil and cement.
- Construct the wall part using bricks up to half height of the shed.
- Fix meshed wire to the upper part of the shed.
- When it is cold and windy, cover the meshed wire part with plastic sheet.

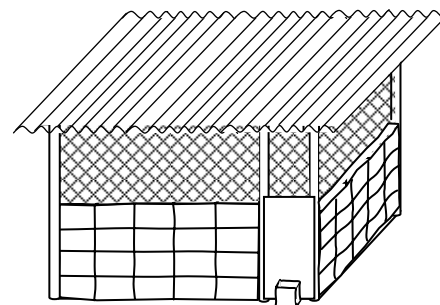

## Bedding Preparation

Ver.2

1. The quality of bedding in chicken housing is crucial. If bedding microbial ecology lose its balance and pathogens increase in it, birds suffer from them. In contrast, good quality bedding contains good nutrients for chickens, pathogens are suppressed by beneficial microorganisms and there is no smell from it. Also, good quality bedding becomes good compost and it is very effective when it is applied to vegetable field as it improves soil quality substantially.
2. How to create good quality bedding? First, put dried leaves, grasses and twigs in 10 cm deep. Then introduce chickens. A week after the introduction, add the same materials in another 10 cm deep. After that add 5 cm of the bedding materials every month.
3. An important point is the difference of required period of time of bedding materials to be decomposed. Dried sorghum leaves and tree leaves, for example, are broken down rapidly. In contrast, twigs need more time to be decomposed. As bedding materials, both rapidly decomposed materials and slowly decomposed materials are needed. So do not forget to mix twigs into the bedding.

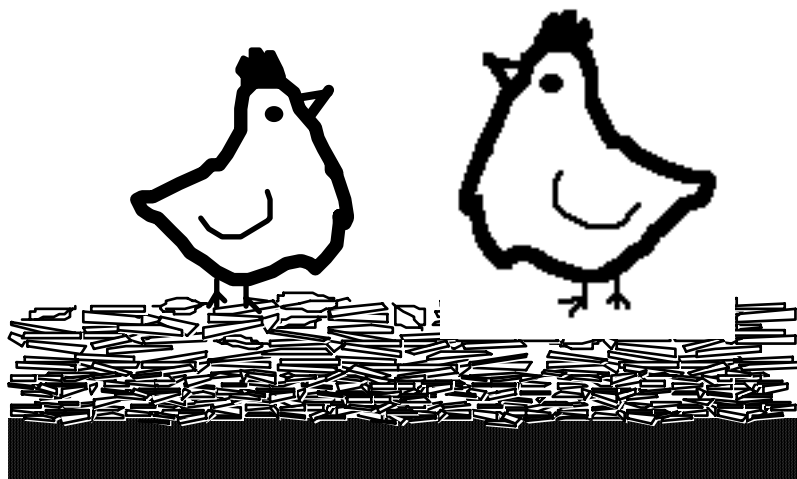

Chickens live on the bedding

### Baby chick introduction

Ver.1

1. Prepare both warm places and cool places in the shed for baby chicks as follows and let them make decisions in the selection of comfortable places.

2. Prepare 2 simple growing boxes using paper cardboard boxes. Fold down 4 wings on one of the largest parts inside. Cut 10 cm high x 20 cm wide as the entrance. Put it upside down on the bedding. There is no paper floor inside.

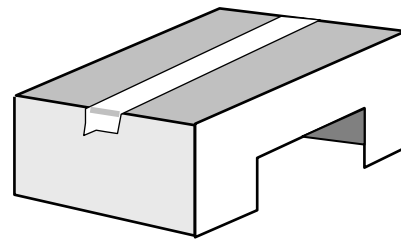

Growing box

3. Prepare a warm bedding point with composting technique. Collect half bucket of raw cow dung. Mix the cow dung with a bucket of dried bedding materials. Dig a hole with 20 cm in diameter and 20 cm deep at about the center of the chicken shed. Put the mixed cow dung with bedding materials into the hole and cover the surface with bedding materials. This point becomes warm after several days. Cover the point with a growing box.

4. Baby chicks always require fresh air but do not like wind. When you have strong wind, cover meshed wire wall with black plastic sheet.

5. After a month, most of them no longer need the growing box. Put perch as their new place to stay. Growing boxes can be removed when no baby chick use them, staying on the perch.

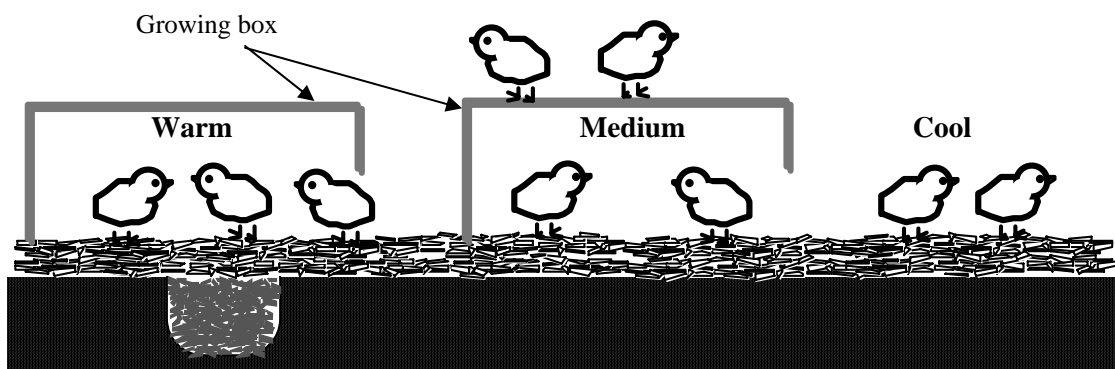

Cow dung with bedding materials produces heat.

## Feeding

Ver.2

Feeding program is divided into 2 phases. Phase I is 8 months from September 2005 to May 2006 and Phase II is after June 2006. In Phase I, the PRIDE team supplies most feedstuff because self-produced feed is not ready. In Phase II, farmers feed self-produced stuff mostly, just buying small amount of supplemental mixed feed from market.

Feedstuff shown below should be mixed well before feeding. Before laying stage, lime can be eliminated from ration. Feeding tips in the chick introduction stage are as follows:

- In the beginning of introduction, the feeding amount shown below is too much because it is for chickens more than 4 weeks. Thus start with less than half amount shown below, observe real consumption by chicks and feed that amount. Increase the amount gradually along with birds' growth. Do not forget to keep the proportion among different feedstuff.
- Even for baby chick whole grains can be fed. They can consume them and their digestive capacity is trained.
- But do not feed silage at the first month of introduction. It is too strong for baby chicks. From the second month, mix a hand of silage (0.1 kg=100 g). If chick shows strong preference for silage, increase the mixing amount gradually.

In the Phase II, earthworms should not be mixed with other stuff. After birds finish almost all feed, earthworms should be fed in the shed, being scattered at least 5 different places within the shed.

### Phase I September 2005 – May 2006

	<u>17 birds/day</u>	<u>month</u>	<u>procurement</u>
Silage	0.5 kg	16 kg	self produced in 1 drum
Sunflower seeds	0.3 kg	9 kg	supplied by PRIDE team
Soya cake	0.4 kg	12 kg	supplied by PRIDE team
Lime	0.1 kg	3 kg	supplied by PRIDE team
Mixed feed	0.5 kg	15 kg	supplied by PRIDE team

### Phase II After June 2006

	<u>17 birds/day</u>	<u>month</u>	<u>procurement</u>
Silage	2.0 kg	60 kg	self produced in 4 drums
Millet	0.4 kg	12 kg	self produced in another 0.1 ha field
Sunflower seeds	0.3 kg	9 kg	self produced in another 0.1 ha field
Earthworm	0.05 kg	1.5 kg	self produced on farm
Mixed feed	0.2 kg	6 kg	purchased from market



## Bedding management

Ver.2

How should you deal with bedding and manure? After manure coming out of birds, composting process starts immediately in the bedding. Bedding should be managed properly for sound composting, in which pathogens decrease and beneficial microorganisms increase.

1. **Stir bedding** sometimes. The first half of composting process is aerobic in upper layer. Aeration is crucial. Birds stir bedding but do partially. You need to stir in parts where composting does not go well. Problem bedding parts give off smell and/or become hard.
2. **Move a perch** sometimes to change the place where manure falls. Birds frequently stay on the perch, including sleeping time in the night. During the stay on the perch, they excrete a lot of manure. You can see more manure under the perch than other places in the shed. Place the perch where you want to have more manure.
3. **Take out necessary amount of bedding** to apply to vegetable fields. After taking out the compost, **add new bedding materials**. Sound composting can proceed in the balance between carbon mainly in bedding materials and nitrogen in manure. As fresh manure is supplied by birds everyday, new bedding materials also should be supplied from outside to keep the carbon-nitrogen balance.
4. **Take out 100% of bedding once a year** to clean inside perfectly.

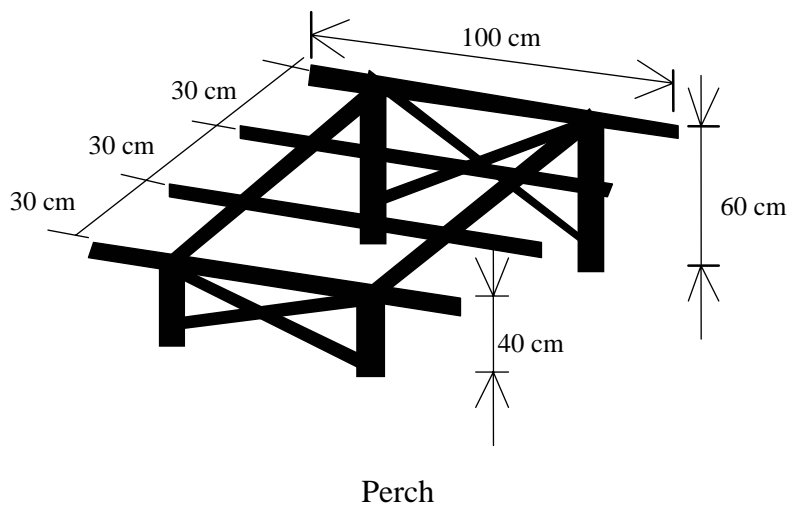

## Soil Building and Compost

Ver.3

1. Soil in the field should be like soil in the forest. Leaves fall down on the surface of forest soil and are decomposed gradually. Leaves are supplied constantly and decomposed downwards constantly to be humus finally. Consequently soil in the forest becomes fertile. Slash and burn shifting cultivation is done based on this rationale.
2. Likewise you can build your soil putting leaves on the surface of your field again and again. But it takes long time for the materials to be decomposed from soil surface. Moreover it is difficult to realize this situation under very dry condition in Sekhukhune.
3. To make soil fertile and healthy practically, mixing compost with soil is very effective. Compost is decomposed organic matters such as leaves, stalks, twigs and kraal manure. Practical compost production is done as follows:
  - a) Collect a couple of 80 kg bags of plant derived materials such as leaves, stalks, crop residues and twigs.
  - b) Collect 1-2 liter of kraal manure and mix it with the plant derived materials.
  - c) Mix a wheelbarrow of field soil.
  - d) Form a heap of 1 m high with the mixed materials
  - e) Cover the surface by plastic sheet to prevent rainwater.
  - f) Keep water level of the heap at 60-70%.
  - g) Turning over once a week by a folk for sufficient aeration.
  - h) It will be matured after a month in summer and 2 months in winter.

Mix matured compost with field soil as base dressing before 2-3 weeks of planting.

3. The essential factors for high-quality compost are as follows:
  - a) Sufficient aeration
  - b) Large portion of plant derived materials with small portion of animal manure
  - c) 60-70% of moisture level
  - d) Mixing soil of the field to which the compost will eventually be applied

## Chicken manure compost

Ver.3

1. In the 0.1 ha integrated farming project, chicken unit has two major products. One is egg and the other is chicken manure compost. The calculation on chicken manure nutrients below shows that 17 chickens produce nitrogen equivalent to 0.4 bag of 20 kg "2:3:2" chemical fertilizer per month. The value of the 0.4 bags of fertilizer is R35 excluding transportation. A farmer can get 4.8 bags or R424 from a chicken shed a year accordingly. Chicken manure compost is no longer "by-product." Utilizing this chicken manure compost, you can grow vegetables very well in the 0.1 ha field.



17 chickens produce nitrogen equivalent to 4.8 bags of "2:3:2" (20kg) a year

2. Semi-automatic composting system in bedding in a chicken shed reduces both composting labor and bad smell. Additionally nutrient balance is improved when chicken manure is composted in bedding. As showed below, phosphorus (P<sub>2</sub>O<sub>5</sub>) and potassium (K<sub>2</sub>O) proportion goes up during composting process.

	water%	N%	P%	K%
Raw chicken manure	74	1.30	1.22	0.60
Composted chicken manure	39	1.76	3.13	1.63

## Laying management

Ver. 2

1. Hens start laying eggs from around 4 - 4.5 months after birth in general. Our hens in the first introduction may start laying at the end of February and hens in the second introduction may start laying eggs at the end of April or in the beginning of May.
2. Let hens to lay eggs in a laying box. Some hens may lay eggs directly on the bedding but those eggs are often eaten by birds themselves. Bottom of the laying box is made slope, on which eggs roll down automatically to the opposite side. You should put small amount of cut grasses on and at the end of the slope. Hens like to lay eggs on the grasses.
3. Hens lay eggs mainly in the morning. Do not wash eggs. When they are dirty, wipe it with soft cloth or paper gently.
4. Inside of the box should be kept dark. Hens do not like dark place except when they are laying. If inside of the box is not dark enough, they stay there even after finishing laying, excreting and making the laying place dirty. Through minimizing staying time in the box, you can keep it relatively clean. Put some new cut grasses on the slope everyday.

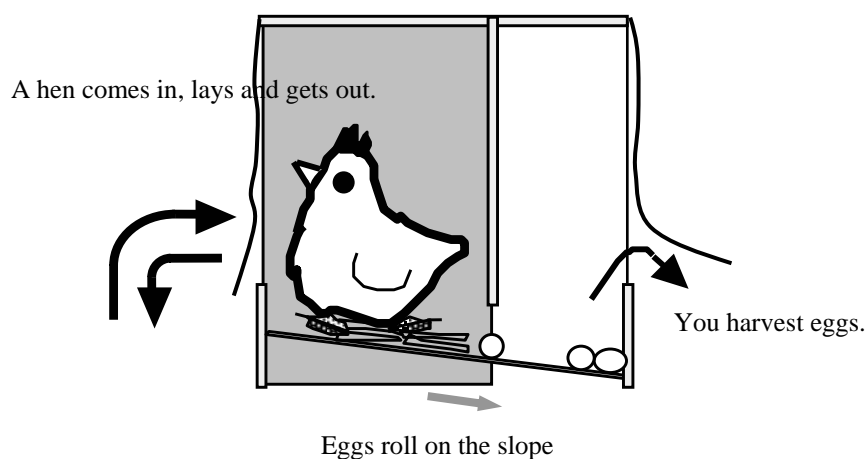

## Indigenous meat chicken management

Ver. 2

1. Indigenous chickens, primarily for meat production, are scavenging around the house. But nutrition may not be sufficient especially in dry season and predators sometimes attack chickens. Semi-confining to a chicken shed from evening to next morning with some supplemental feed is recommended.

2. The strength of indigenous meat chicken production is that they are still keeping broodiness. Most indigenous hens can hatch on her own while commercial layers and broilers have already lost their broodiness. Common propagation cycle is as follows:

- i) A hen lay 10 – 13 eggs in 2 – 3 weeks
- ii) They stop laying and sit on the eggs to hatch for 3 weeks
- iii) Baby chicks take 20 – 22 weeks to be matured for marketing.

3. Even hens that are keeping broodiness, they hatch in summer more than in winter because they know if they hatch in dry winter, baby chicks cannot survive due to lack of feed in nature. As a result, a hen hatches once or twice a year mainly in summer though she lay eggs even in winter.

4. For example, when you keep 4 hens and a cock, you can expect 6 clutches, which is 1.5 times of hatching per hen per year in average. If a hen hatches 10 chicks as a clutch, you can get 60 chickens for marketing in total.

5. A simple nest box is recommended. If you have a 20 liters plastic container, cut the 70 % of front part as an entrance and put dried grasses or leaves in it. Put the nest box in relatively dark and cool places in the shed. Put feed and water outside of the box to allow the hatching hen to eat and drink twice a day. In very dry weather, sprinkle water on eggs every other day to add moisture.

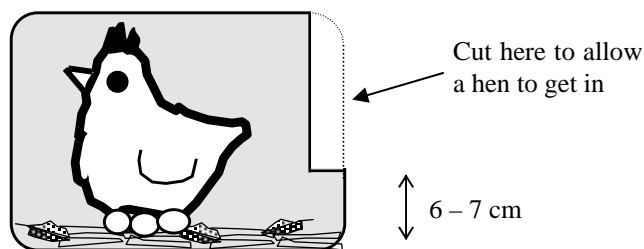

20 liters plastic container

## 4 .参加型土壌保全実施ガイドライン・ メンテナンスマニュアル

**Limpopo Province  
Republic of South Africa**

**Management Guideline  
for  
Project Staff Members from  
LDA, Districts, Sub-districts and Municipalities  
To Implement  
Community Soil Conservation Project**

**March 2007**

**Limpopo Province Department of Agriculture**

**JICA Study Team**

**For the Study on the Integrated Holistic Rural Development  
and Soil Conservation Programme in Schoonoord Area, Sekhukhune  
District, Limpopo Province in Republic of South Africa**

**Management Guideline for Project Staff Members  
from LDA, Districts, Sub-districts and Municipalities to Implement  
Community Soil Conservation Project**

**Table of Contents**

<i>1. Introduction</i>	-----	<i>1</i>
<i>1.1 Objectives and contents of this guideline</i>	-----	<i>1</i>
<i>1.2 Logical framework of the project</i>	-----	<i>2</i>
<i>1.3 Typical layout plan of the project</i>	-----	<i>4</i>
<i>1.4 Overview of processes of the project</i>	-----	<i>6</i>
<i>1.5 Implementing system</i>	-----	<i>8</i>
<i>2. Implementation of community soil conservation activities</i>	-----	<i>10</i>
<i>2.1 Preparation</i>	-----	<i>10</i>
<i>2.2 Participatory planning</i>	-----	<i>13</i>
<i>2.3 Construction and construction supervision</i>	-----	<i>17</i>
<i>2.4 Planting work</i>	-----	<i>18</i>
<i>2.5 Construction of nurseries</i>	-----	<i>24</i>
<i>3. Monitoring and evaluation</i>	-----	<i>29</i>
<i>3.1 Monitoring of inputs and outputs</i>	-----	<i>29</i>
<i>3.2 Sample evaluation grid</i>	-----	<i>31</i>
<i>3.3 Sample form of evaluation</i>	-----	<i>33</i>



## **1. Introduction**

### **1.1 Objectives and contents of this guideline**

This guideline aims at providing a project staff team, in charge of the implementation of the community soil conservation project in cooperation of target communities, with a guide to plan, implement, monitor and evaluate the project.

This guideline is divided into three sections. The first section “Introduction” contains the outline of the project and the description of the implementing system for the project. The second section “Implementation of soil conservation activities” contains the standard methods of the implementation of the project. The third section “Monitoring and evaluation” contains the standard format of the monitoring and the evaluation of the project.

This guideline will be modified and updated in accordance with accumulated experiences of the project in the future.

## 1.2 Logical framework of the project

The logical framework indicates the relationships of inputs, activities, outputs and outcomes, that is, what inputs bring what activities, what activities bring what outputs, and what outputs bring what outcomes. The logical framework is useful for understanding the characteristics of the project. Also, it is a basis for the monitoring and the evaluation of the project because it mentions the indicators for measuring the outputs and outcomes, and because the relationships of inputs, activities, outputs and outcomes are the bases of the evaluation of the project.

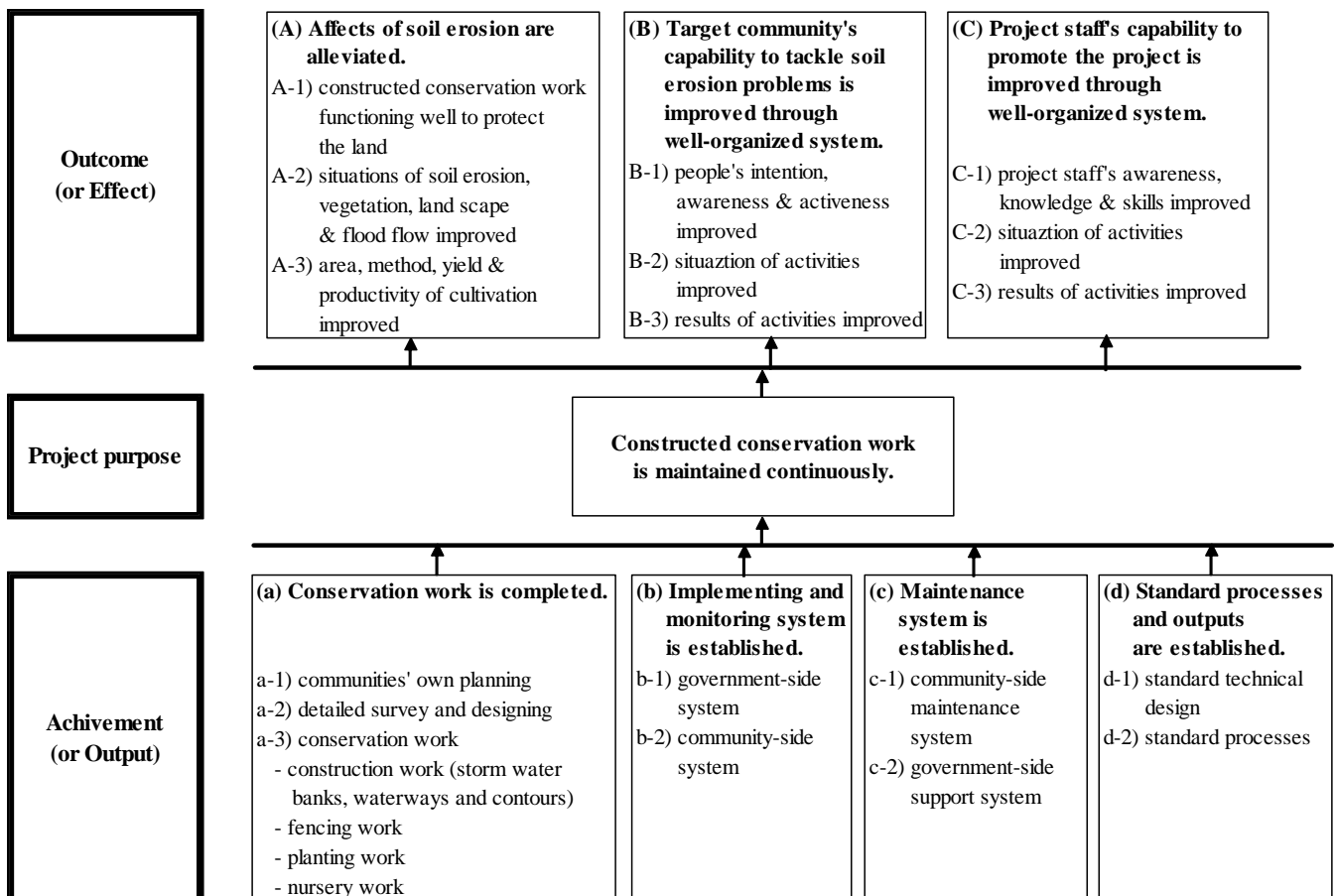

**Relationships of outputs and outcomes indicated in logical framework**

### Logical framework of community soil conservation project

Project Summary	Indicators	External conditions
<p><b>Overall Goal</b></p> <p>A) Impact of soil erosion is alleviated.</p> <p>B) Ability of the target communities to address soil erosion problems is improved.</p> <p>C) Ability of project staff to carry out soil conservation projects is enhanced.</p>	<p>A) Condition of soil erosion, floods, vegetation, area of land with farm crops and crop yields.</p> <p>B) Changes in awareness, initiative, technical knowledge and management skills.</p> <p>C) Changes in awareness, initiative, technical knowledge and management skills.</p>	<p>There is no flood damage so severe that it exceeds the capacity of soil conservation structures to withstand it.</p>
<p><b>Project Purpose</b></p> <p>The soil conservation structures built in the project are maintained regularly and sustain their necessary functions.</p>	<p>Maintenance status, sustainability of functions of soil conservation structures, sustainability of maintenance system.</p>	<p>There is no flood damage so severe that it exceeds the capacity of soil conservation structures to withstand it.</p>
<p><b>Output</b></p> <p>a) Soil conservation structures are completed.</p> <p>b) An implementation and monitoring system is built up on both LDA and community sides.</p> <p>c) Maintenance system is devised on both LDA and community sides.</p> <p>d) A model is established, including a standard design, a standard implementation process and a standard implementation system.</p>	<p>a) Functionality of soil conservation structures.</p> <p>b) Functionality of implementation and monitoring systems.</p> <p>c) Functionality of maintenance systems.</p> <p>d) Model's technical completion and effectiveness.</p>	<p>There is no severe flood damage before the output created in this project brings about a good effect.</p> <p>There is no vandalism by neighboring communities.</p>
<p><b>Activities</b></p> <p>a-1) Planning, surveying and designing</p> <p>a-2) Civil engineering and construction work</p> <p>a-3) Fence construction</p> <p>a-4) Forestation and planting</p> <p>a-5) Create nursery garden (option)</p> <p>a-6) Monitoring and evaluation</p> <p>a-7) Maintenance</p> <p>b,c-1) Organize community residents and organize administration's project staff</p> <p>b,c-2) Participation of community and project staff in activities a-1) – a-7)</p> <p>b,c-3) Prepare and distribute guidelines and manuals</p> <p>d-1) Create model based on existing criteria, lessons from cases in the past, and project experience and achievements</p> <p>d-2) Verify effectiveness of model in project implementation</p> <p>d-3) Prepare and distribute guidelines and manuals</p>	<p><b>Input</b></p> <p>Materials: Used tires, vetiver, nursery trees, and others</p> <p>Equipment: Bulldozers, graders and others</p> <p>Staff: Local consultants Surveyors Builders Community residents Project staff</p> <p>Funding: JICA R 454,000 LDA R 15,476,000 <u>District R 230,000</u> Total R 16,160,000</p> <p>(Please refer to "3.6.2 Input" for details.)</p>	<p>There is no severe flood damage before the soil conservation structures are completed.</p> <p>There is no vandalism by neighboring communities.</p> <p><b>Prerequisite</b></p> <p>The administrative side provides financial support.</p>

### **1.3 Typical layout plan of the project**

The project consists of the following basic components, which are expected to produce synergic effects.

#### **a. Construction work**

Damage caused by floods and soil runoffs is minimized and erosion aggravation is prevented through the construction of storm water banks, waterways, and contours. In addition, waterways are protected from flood-caused erosion through the construction of waterway protection structures.

Storm water banks catch the flood flow from the mountain side, leading the flow into waterways. Also, contours catch the rain water inside the target area, leading it into waterways. Thus, the flood flows downwards safely

#### **b. Planting work**

Storm water banks, contours, waterways and other structures are protected from flood-caused erosion through forestation and planting. In order to secure long-term continuity of these activities, local people's awareness of the need for environment protection is raised through their participation in forestation and planting works.

#### **c. Fencing work**

Fences are built in order to protect the vegetation from cattle and to contribute to its recovery.

#### **d. Nursery work (optional)**

Construction works for tree nurseries may be added optionally when target communities wish to produce seedlings as a way of contributing to soil conservation and greening activities in neighboring areas, or as a way of earning additional income.

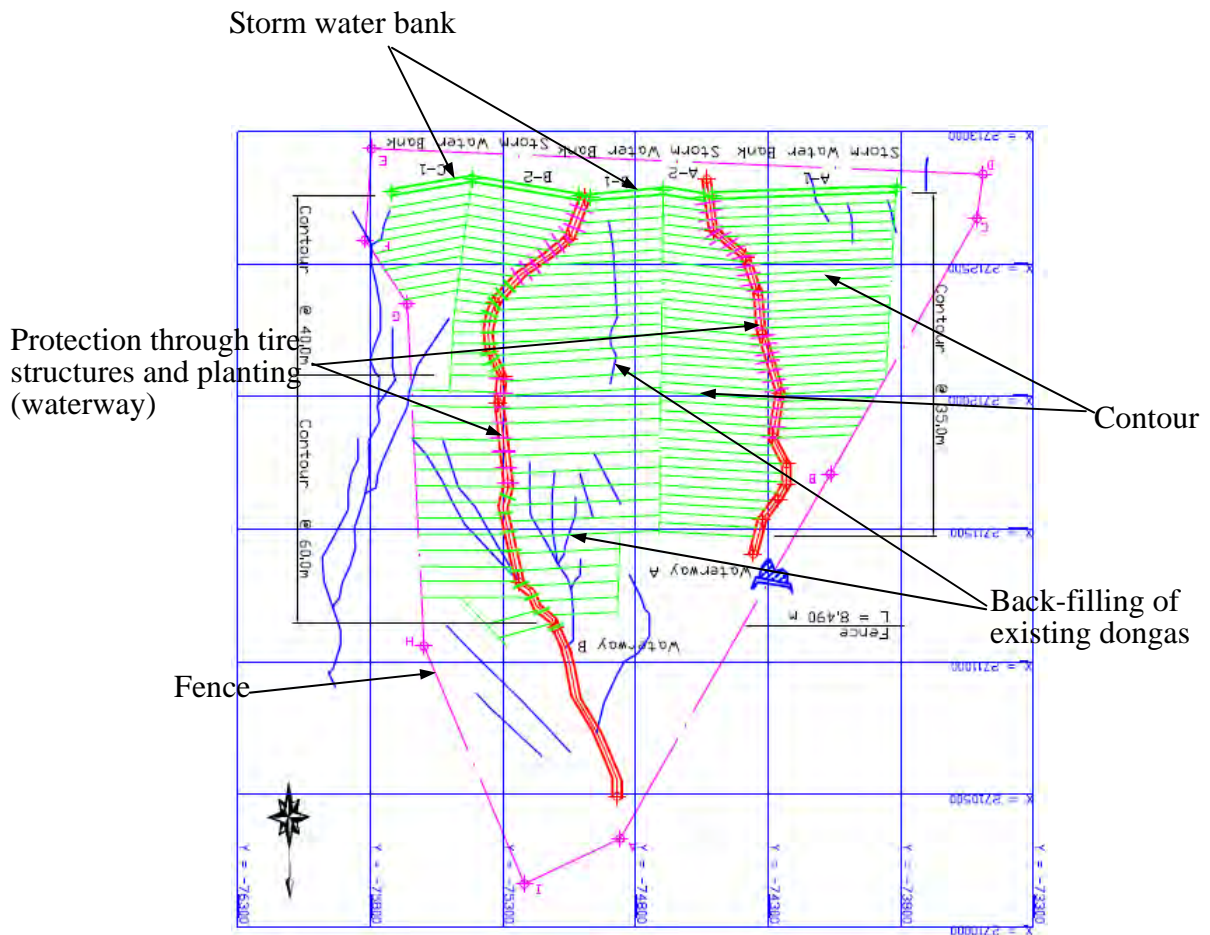

**Typical layout plan of the project**

## **1.4 Overview of processes of the project**

The processes of the project are described below:

- 1st year – Preparation phase: Applications from communities, screening, and selection.
  
- 2nd and 3rd year – Implementation phase:
  - 2nd year: Creation of participatory plans; completion of waterways and waterway protection.
  - 3rd year: Storm water banks, contours, forestation and planting, and fence completion.
  
- From the 4th year - Maintenance phase: Maintenance of completed structures, planted trees and grasses.

With regard to implementation phase processes, the construction of waterways and waterway protection structures in the 2nd year should be completed in the first half of the rainy season (November and December), when precipitation is still moderate, in order to avoid the possibility of flood damage during the construction. Planting for waterway protection should also be completed during the first half of the rainy season, in order to achieve vegetation growth from the early stages of the works.

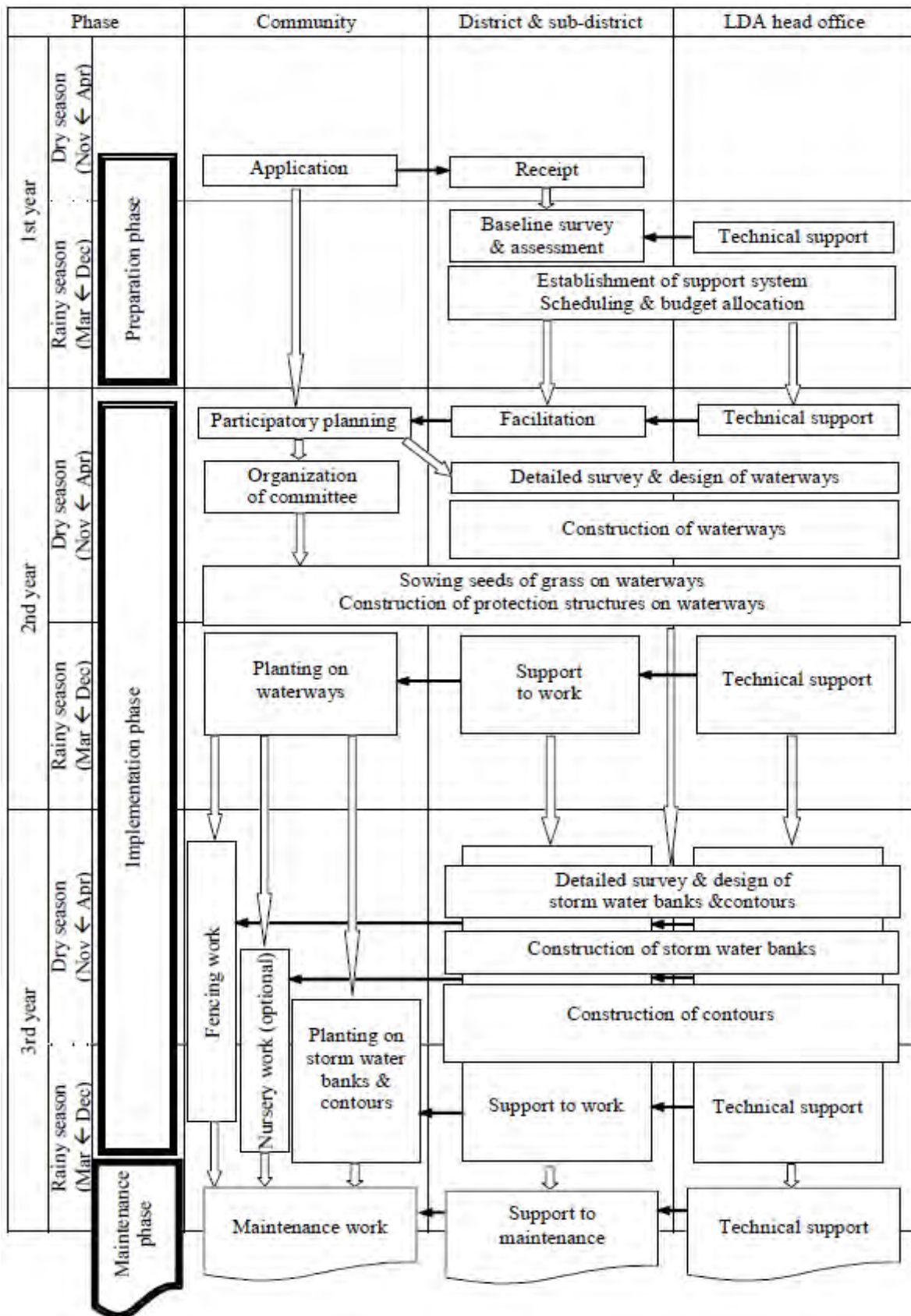

Standard processes of the project

## 1.5 Implementing system

As a system for the implementation of activities in the master plan, LDA forms “activity units” composed of 1 Head Office member, 1 district office member and several extension officers. These activity units act as implementation units for promoting community soil conservation activities.

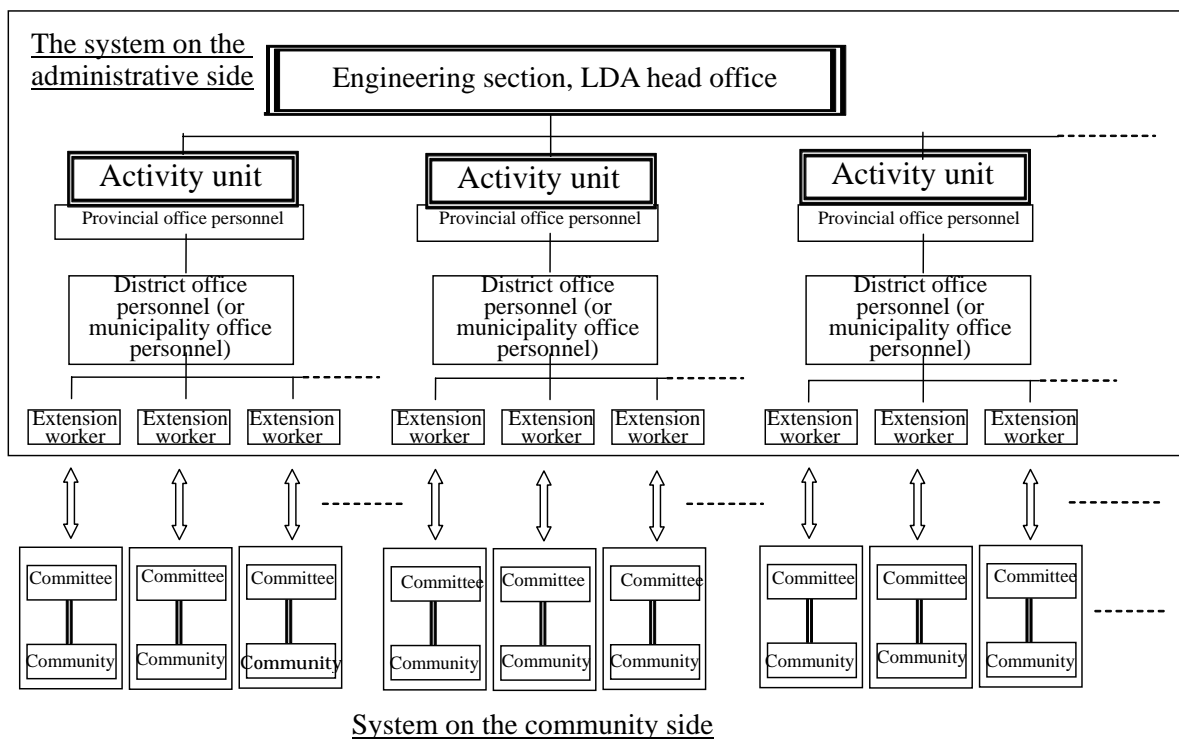

**Proposed implementing system for the project**



### Demarcation of roles

Related parties	Division of roles
Community members	<p><b>Actors of planning, implementation, and management activities</b></p> <ul style="list-style-type: none"> <li>- Applications for project implementation</li> <li>- Participation in activities of participatory planning</li> <li>- Organization of committees</li> <li>- Participation in construction activities, forestation and planting activities</li> <li>- Implementation of sustainable maintenance activities</li> </ul>
Extension officers	<p><b>Instructions and guidance to residents</b></p> <ul style="list-style-type: none"> <li>- Communication with communities</li> <li>- Facilitation of the community activities</li> <li>- Instructions and support to the community activities</li> <li>- Assistance to the activities of district office personnel</li> </ul>
District office	<p><b>Arrangements for various activities</b></p> <ul style="list-style-type: none"> <li>- Support to the activities of the extension officers</li> <li>- Coordination of various project activities</li> <li>- Assistance to the activities of Head Office personnel</li> </ul>
Head Office	<p><b>Technical and financial support</b></p> <ul style="list-style-type: none"> <li>- Screening and selection of target communities</li> <li>- Coordination within the Head Office and with relevant institutions</li> <li>- Detail survey and designing</li> <li>- Procurement of constructors</li> <li>- Supervision of works executed by constructors and the communities</li> <li>- Support for the procurement of materials and machines</li> </ul>

## **2. Community soil conservation activities**

### **2.1 Preparation**

Applications are received from communities, and target communities are selected based on the following screening criteria.

- Objective of the soil conservation project
- Situation of candidate target areas – inclination, water availability, soil, vegetation, and farming
- Community organization
- Local people's willingness

## Sample application form from communities

**LIMPOPO PROVINCE  
REPUBLIC OF SOUTH AFRICA**

### **ELEMENT: Community Soil Conservation Project**

#### **PARTICULARS OF APPLICANT**

Name of Organised farmers / Association / Union:

\_\_\_\_\_

Name of Village: \_\_\_\_\_

Postal address: \_\_\_\_\_

\_\_\_\_\_

\_\_\_\_\_

Municipal Area: \_\_\_\_\_

Farm name: \_\_\_\_\_

#### **APPLICATION**

At a project meeting held on \_\_\_\_\_ the following was resolved:

1. All the members are desirous to apply for the implementation of the community soil conservation project on the farm(s) as indicated above.
2. All the members will accept ownership of the conservation works and activities of the pilot project.
3. All the members have committed themselves to maintain and develop the activities initiated by the pilot project throughout and after the completion of the pilot project.
4. All the members have committed themselves to participate in the project implementation process either in kind or financially or both. More specifically, all the members have committed to the following activities:
  - Establishing a project committee for managing the pilot project
  - Participating in planning and design of conservation works
  - Work of planting trees and grasses
  - Work of taking care of trees and grasses
  - Maintenance work of conservation works, such as work of removing silts, repair work when damaged
5. It is also resolved by the full committee that \_\_\_\_\_ is authorized to sign on behalf of the committee all documentation relevant to soil conservation.

Signed (number of necessary signatures can be changed according to necessity of the pilot projects)

1.	_____	_____	_____	_____
		Name in Block Letters	Designation	Date
2.	_____	_____	_____	_____
		Name in Block Letters	Designation	Date
3.	_____	_____	_____	_____
		Name in Block Letters	Designation	Date
4.	_____	_____	_____	_____
		Name in Block Letters	Designation	Date
5.	_____	_____	_____	_____
		Name in Block Letters	Designation	Date
6.	_____	_____	_____	_____
		Name in Block Letters	Designation	Date
7.	_____	_____	_____	_____
		Name in Block Letters	Designation	Date
8.	_____	_____	_____	_____
		Name in Block Letters	Designation	Date
9.	_____	_____	_____	_____
		Name in Block Letters	Designation	Date
10.	_____	_____	_____	_____
		Name in Block Letters	Designation	Date
11.	_____	_____	_____	_____
		Name in Block Letters	Designation	Date
12.	_____	_____	_____	_____
		Name in Block Letters	Designation	Date
13.	_____	_____	_____	_____
		Name in Block Letters	Designation	Date
14.	_____	_____	_____	_____
		Name in Block Letters	Designation	Date
15.	_____	_____	_____	_____
		Name in Block Letters	Designation	Date
16.	_____	_____	_____	_____
		Name in Block Letters	Designation	Date
17.	_____	_____	_____	_____
		Name in Block Letters	Designation	Date

## 2.2 Participatory planning

A participatory planning is conducted using PRA method, with Head Office, district office and extension officers acting as facilitators.

- Grasping the situation based on transect work and resource mapping
- Discussion of problems and possible solutions
- Discussion of the soil conservation plan
- Creation of the soil conservation map

We follow the following procedure in the PRA activities:

1. to select a task team of around 10 to 15 members as participants of the activities.
2. to select a target area, the size of which is as big as illustrated on the right.
3. to draw a base map which covers the whole area of (A), (B), (C) and (D), and which indicates the location of major roads, rivers, houses, gardens, farmland and other landmarks.
4. to conduct a transect walk and resource mapping of a model area (A).

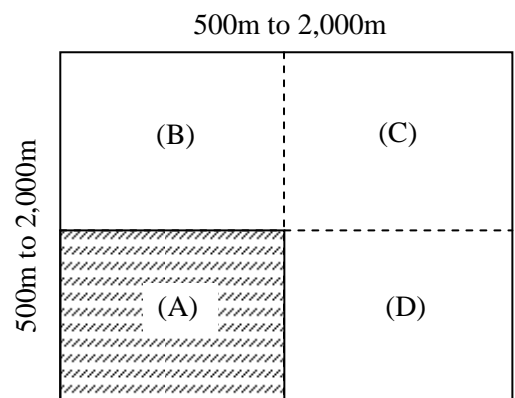

All the team members join the activity in the model area, and the field staff acts as facilitator. They are supposed to learn the method of survey and mapping.

The points of observation in this activity are:

- location, size and direction of soil erosion
  - situation of vegetation and possible reason of its degradation
  - predicted extent of soil erosion
5. to subdivide the task team into three small groups composing of 3 to 5 members.
  6. to conduct a transect walk and resource mapping of other areas (B), (C) and (D). Each subdivided group is assigned to the survey and mapping of the area of (B), (C) or (D).
  7. to hold a session in which each subdivided group make presentations on their own findings.

The purpose of the session is to have a common understanding among the task team and other community members.

Through these activities, a soil conservation map illustrating the plan of structures is drawn by the community. In addition, the project staff team conducts a detailed survey and designing work based on the community's soil conservation map with the assistance of a local consultant.

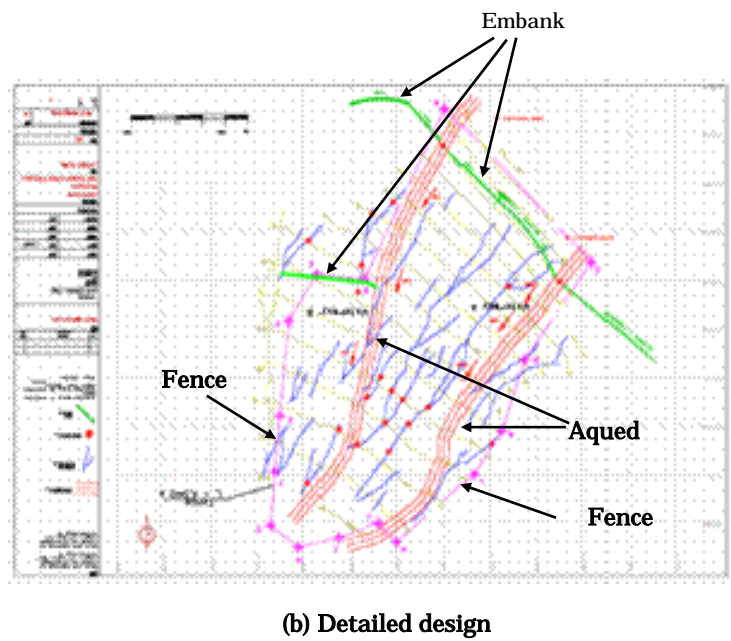
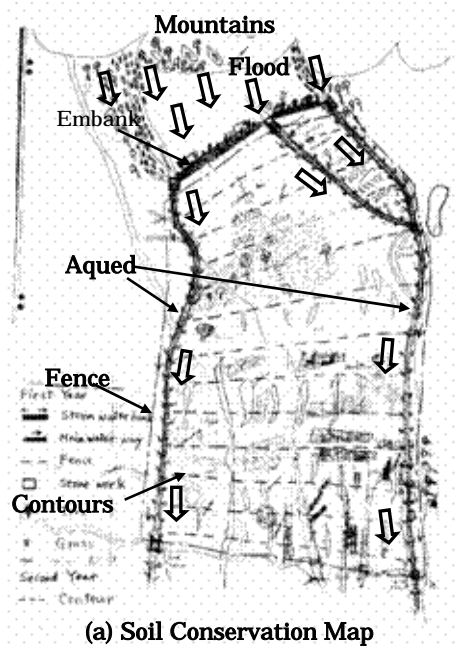

## Design of waterways and their protection structures

The waterway cross section is indicated below. Waterway flow rate, depth and width are determined in such a way as to ensure safety against flood flow.

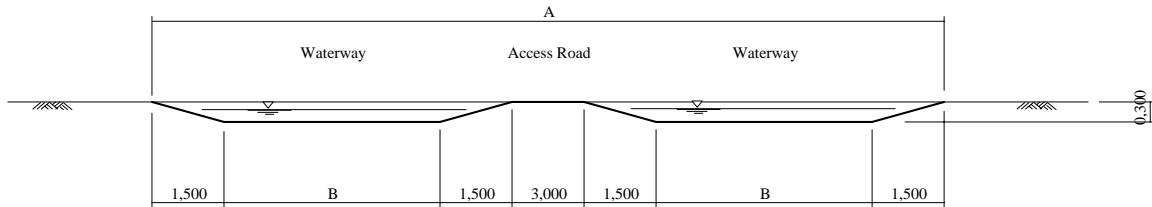

The following waterway protection methods need to be used in order to prevent waterway surface from being deteriorated through erosion.

- Waterway protection structures built at regular intervals along waterway  
Materials such as stones and waste tires are used to build these structures. As the vegetation cover protects the waterways even when it is not fully grown or when its growth is uneven, it should be used as a complementary protection form.
- Development of a vegetation cover across the entire surface of the waterways  
Before building the waterway protection structures, seeds of bermuda, tef and other herbaceous plants are sown over the waterway area, and fertilizer is applied. After the waterway protection structures are build, the vegetation cover starts to form gradually over the waterways, protecting them from erosion.
- Planting vetiver grass on waterway slopes and at the top of the slopes  
Vetiver grass is planted on waterway slopes and slope tops in order to protect them. Special attention is given to the places such as storm water banks, and where contours flow in.

As shown in the figure below, waterway protection structures are built at regular intervals along the waterways in order to prevent deep erosion of the bottom of the waterway.

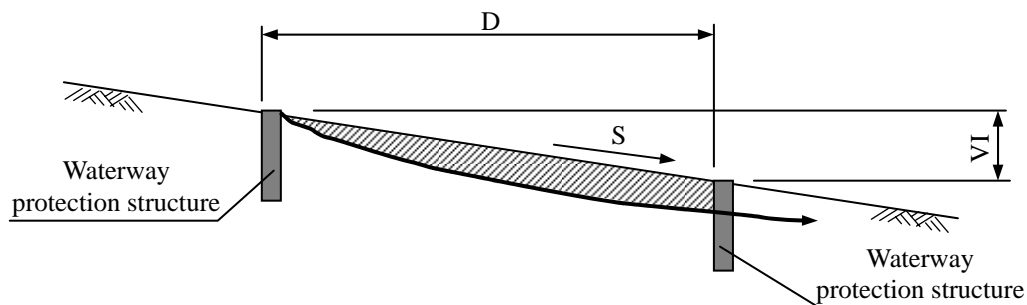

The next figure shows the cross-section of waterway structures. Materials such as stone and waste tires are used. Structures made of waste tires can consist either of a

combination of tires placed horizontally and vertically, or of tires placed only horizontally, in the case of gentle slopes.

Type 1

- Using stone materials

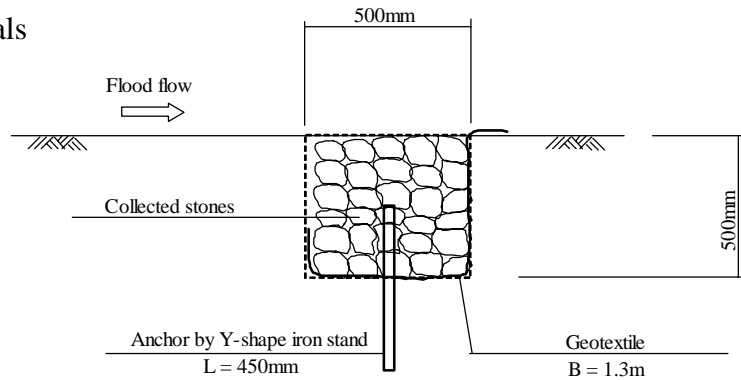

Type 2

- using waste tires

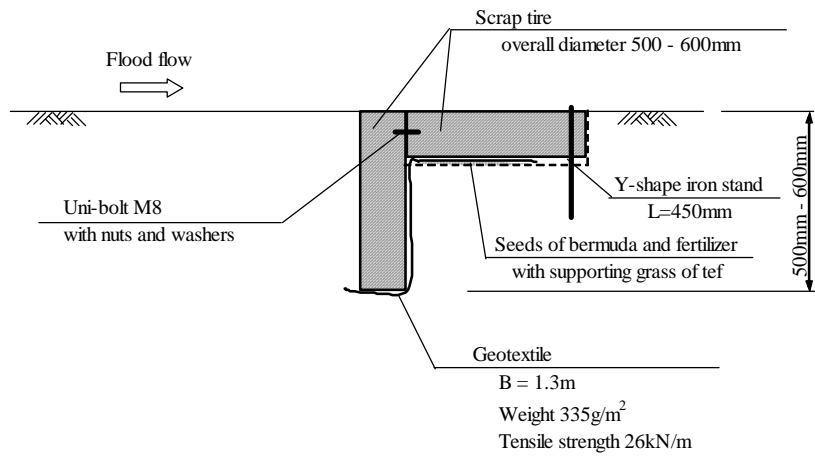

Design of storm water banks and contours

The cross-section of storm water banks and contours is shown below.

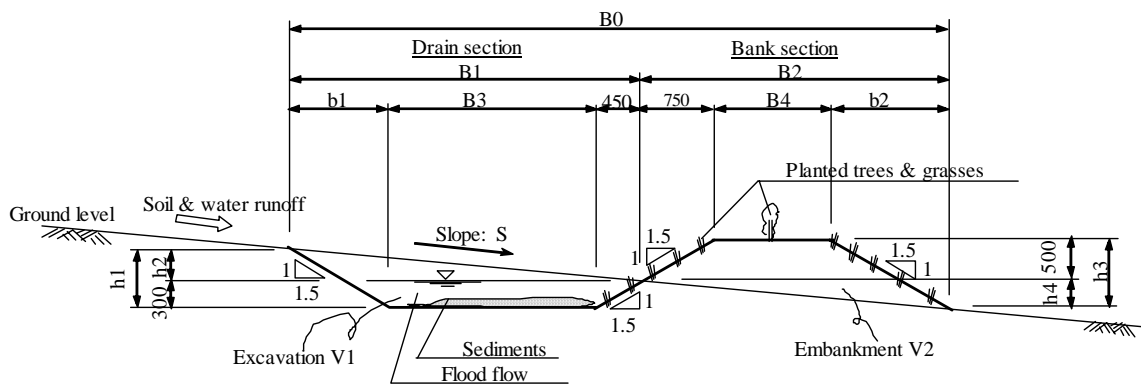



### **2.3 Construction and construction supervision**

The project staff team provides support in the following areas.

- a. Detail survey and designing
- b. Procurement of contractors
- c. Supervision of construction work and planting work with the residents' participation

Important issues in the construction and the construction supervision are:

- Each member of the project staff team visits the project site at least two or three times a week, and inspect and confirm the progress and the quality of the work, if the actual work follows the design..
- The project staff team holds a meeting with the contractor and the committee of the target community at least once a month about the progress, the quality of the work, and any measures to be taken if there are any problems.
- The project staff plays a key role in communication between the contractor and the community, assistance and arrangements of procurement of labor from the community, assistance and arrangements of procurement of particular materials, such as tires, seeds of grasses, vetiver grasses and tree seedlings, and particular equipment, such as tractors from neighboring farmers.

## 2.4 Planting work

### 2.4.1 Procurement of materials

#### 1) Seedlings

Some characteristics required for tree species to be planted in project sites are drought resistant, useful for local people, fast growing, and easy to propagate. Appendix VII provides the recommending list of some indigenous species for this purpose.

The list of nurseries in and around Sekhukhune and the price of a seedling in each nursery are shown in the next page. If the detail of planting activities is decided, contact those seedling producers to secure enough number of seedlings. Some nurseries are ready to provide seedlings by ordering in advance.

#### 2) Equipments and tools

Basic equipments and tools necessary for planting activities at project sites are listed below. Average unit prices are also shown below, although the prices vary from shop to shop. The number of equipments to be required depends on the size of activities.

Name of equipment	Unit price
A water tank (JoJo tank) (0.5 ton)	R1,300.00
A set of connecting parts to a tank	R120.00
A thick watering hose with 30m long	R585.00
A concrete bucket	R70.00
A shovel	R60.00
A watering can	R23.00
A panga	R16.00

#### 3) Transporting materials

If your own transports are not available, some carriers must be hired for transporting materials such as seedlings.

Mean of transport	Cost per day
1 lorry (2 ton)	R
1 trailer for a car	R300.00

List of Nursery in and around Sukhukhune

Name	Status	Location/Address	Contact	Availability	Price	Remarks
1 Radlwana Nursery	JICA pilot project	Radlwana	Ms. Onishi (Supporting staff of JICA Study Team, Tel 072-437-0379)	Manula, Papaya, Orange, Coral tree, Acacia, etc	R1 0.00	Started In late 2004
2 Ga-Kopane Nursery	JICA pilot project	Ga-Kopane	Ms. Onishi (Supporting staff of JICA Study Team, Tel 072-437-0379)	Peach, Guava, Papaya, etc	R1 0.00	Started In late 2004
3 Ruesclass Nursery	DWAF nursery	near Labolekgoro	Office (Tel 015-632-5181), Mr Willard Sefara (Manager Tel 088-640-5576), Mr. Obat (Forester at the nursery)	Manula, Guava, Mango, etc	R4 00 – 8 000	Seeds can be provided by ordering
4 Eula mahlo Nursery	Eulamaho Project (NAD)	before Tzaneen (from Polokwane on your right)	Association "Thusanang" Karin boyang (Secretary? Tel 015-267-1100), Maria muliba (Nursery manager? Tel 073-231-2748)	Many indigenous species (Manula, Acacia karoo, Diospyros whyteana, Acacia anthelmintica etc	R1 0.00	Open Thu-Sat
5 Magoetsekoof Indigenous Plant	Private	Tzaneen (from Polokwane on your left)	Mark Hamman (Owner or manager Tel 084-402-8708), Piet (Employee, Tel 083-437-6516)	Many indigenous species but not large number	R27.00	Price will be discounted if purchased many, Other seedlings might be stocked in another place
6 Wheelbarrow Nursery	Private	Tzaneen (from Polokwane on your left)	Tel 015-905-8088	Indigenous trees and fruit trees, but not in large number	R15.00 – 150.00	Mainly for gardening. Price is rather expensive. Probably difficult to obtain large number of seedlings
7 Bergsig Nursery	Private	Polokwane	LW Tenblanche (Owner. Tel 015-288-8174, 086-407-2368)	25 species of indigenous trees	R25.00	
8 Wonderboom Training Center	LDA	Axel (near Olfants River)	Mr. Mphahle (Tel 082-852-7822)	Vetiver grass	-	Vetiver grass only

## **2.4.2 Managing planting work (1) – Planting vetiver grasses**

### **1) Digging up vetiver slips**

To remove a clump of vetiver grass from the nursery, dig it out with a spade or fork. Even agricultural machines are useful for digging if they are available. The root system is too massive and strong for the grass to be pulled out by hand. Next, tear a handful of the grass, roots and all from the clump (Figure A). The resulting piece, the slip, is what gets planted in the field.

### **2) Preparing vetiver slips**

Before transplanting, cut the top of each slip off about 15-20 centimeters above the base, and roots 10 centimeters below the base. This will improve the slips' chances of survival after planting by reducing transpiration level and thereby preventing them from drying out. The Finished planting piece is shown in figure B in the next page.

### **3) Planting vetiver slips**

The slips must be planted at the beginning of the wet season to ensure that they get full benefit of the rains. Make a hole at first. Push the slip into the hole, taking care not to bend the roots upward. Then, firm the slip in the soil. 10 - 15 centimeter from the slip, plant the next slip, and so on (Figure C). Watering is sometimes required just after planting, if the ground moisture seems to be low.

(Reference: Vetiver grass (World bank; 1990, ISBN 0-8213-1405-X) )

**Figure A Digging up vetiver grasses**

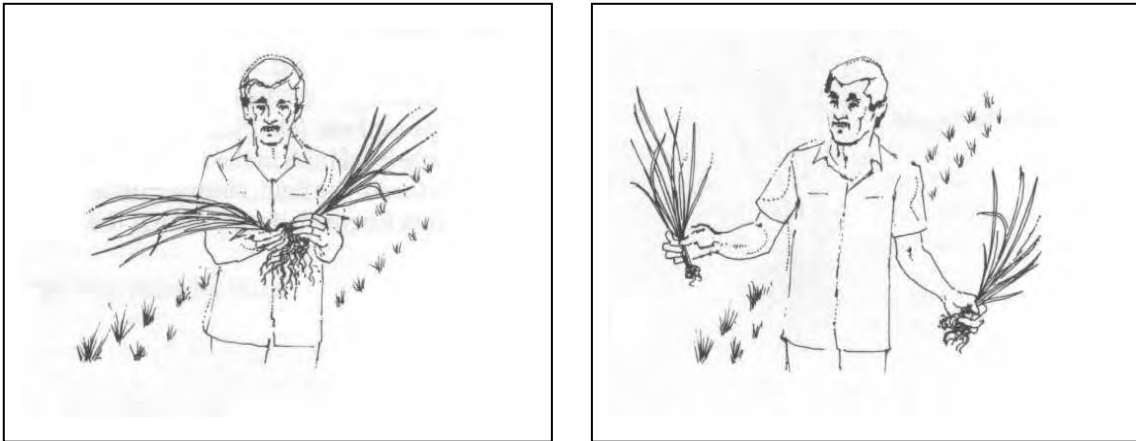

**Figure B Preparation of vetiver slip**

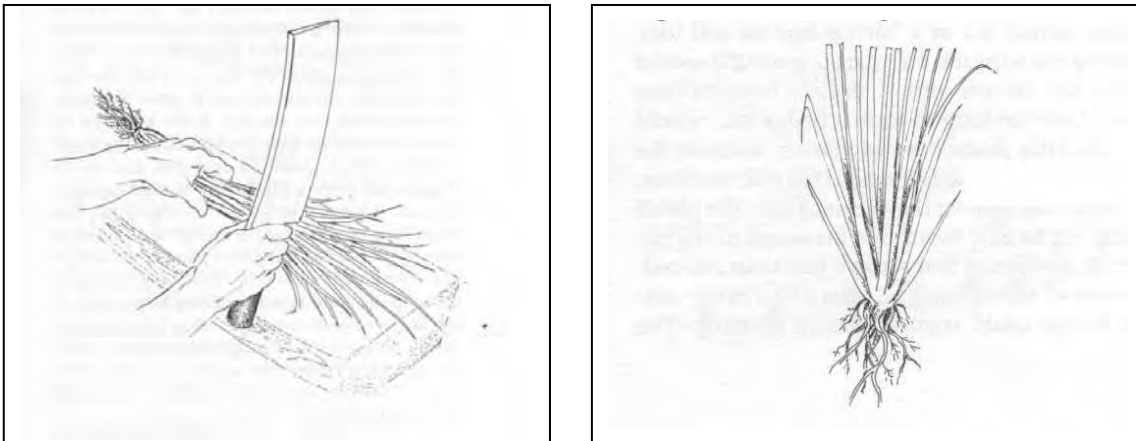

**Figure C Planting vetiver slips**

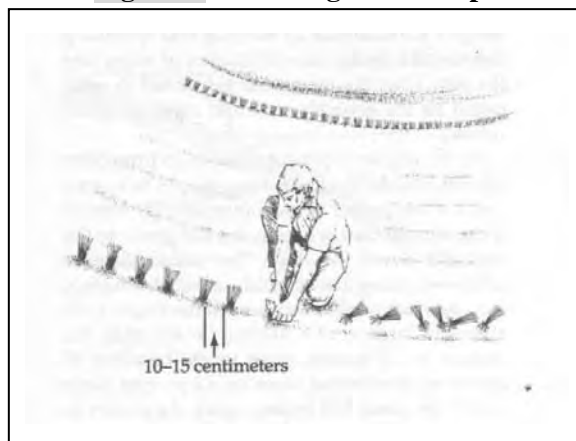

(Reference: Vetiver grass (World bank; 1990, ISBN 0-8213-1405-X) )

### 2.4.3 Managing planting work (2) – Planting tree seedlings

#### 1) Required quality of seedling

Seedlings with good quality must be selected if possible. Some checking points for choosing good seedlings are as followings:

- Having thick and straight stem
- Bearing many leaves of dark greenish color
- Having well developed root system (inside pot is filled with rootlets)
- The size of stem is balanced with the size of pot
- Not having disease or harmful insects

#### 2) Treatment of seedlings before transplanting

Usually seedlings are produced under shading nets in nurseries. Before transplanting, seedlings must be grown under direct sun light for a month for adapting themselves to the harsh environment of a field. However, those seedlings must be watered enough until those are planted in a field.

#### 3) Planting seedlings

Ideally, planting is carried out at the beginning of the rainy season.

##### a. Preparation of planting pits

- Dig a pit for planting tree. The size should be 40cm × 40cm in length and 40cm in depth in minimum case. ( ) (This space is important for young trees to secure the space of developing their root systems at the initial stage of growing, as natural earth ground is often very hard for their roots to penetrate.)
- Fill up a pit with dug up soil a little, to provide soft soil even underneath of seedling's roots. ( )

##### b. Planting a seedling

- Dip a seedling with plastic bag into water and soak water into its soil.
- Cut and open one side of a plastic bag and remove it from soil “cylinder” with care not to break the clump of soil around roots.
- Place a seedling with soil “cylinder” at the center bottom of a planting pit. The level of collar region (the base of a seedling stem) should be slightly lower than the ground level, which allows water (rain) to flow in and remain around the planted tree longer. ( )
- Fill up a pit with soil to the height of collar region, and compact the soil. ( )
- Give bucketful water (about 15 liters) to the planted “basin” (to the bottom of seedling).

### Characteristics of seedling

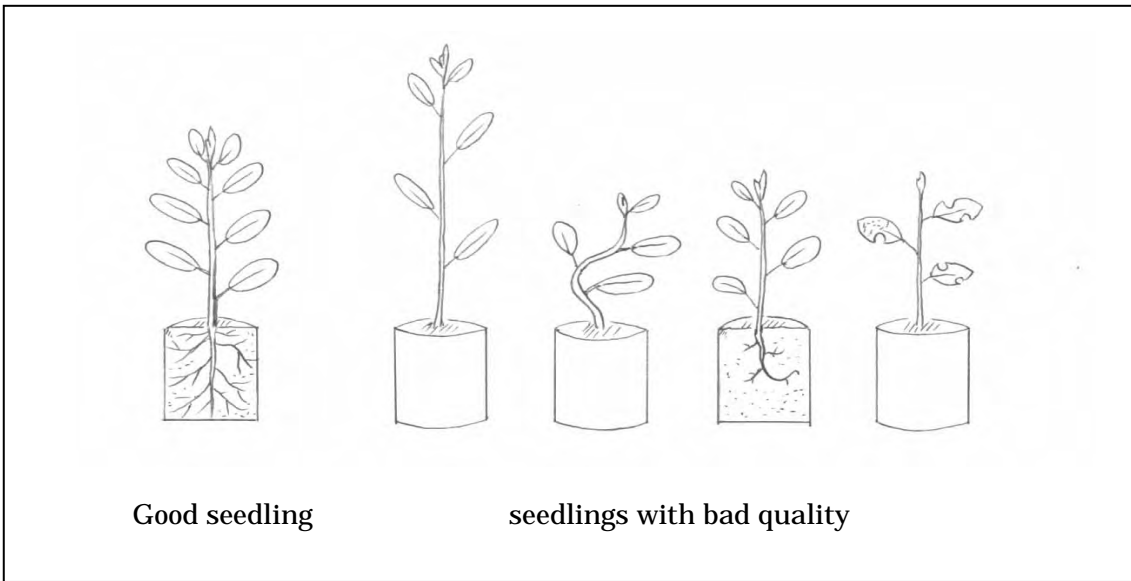

### Planting seedlings

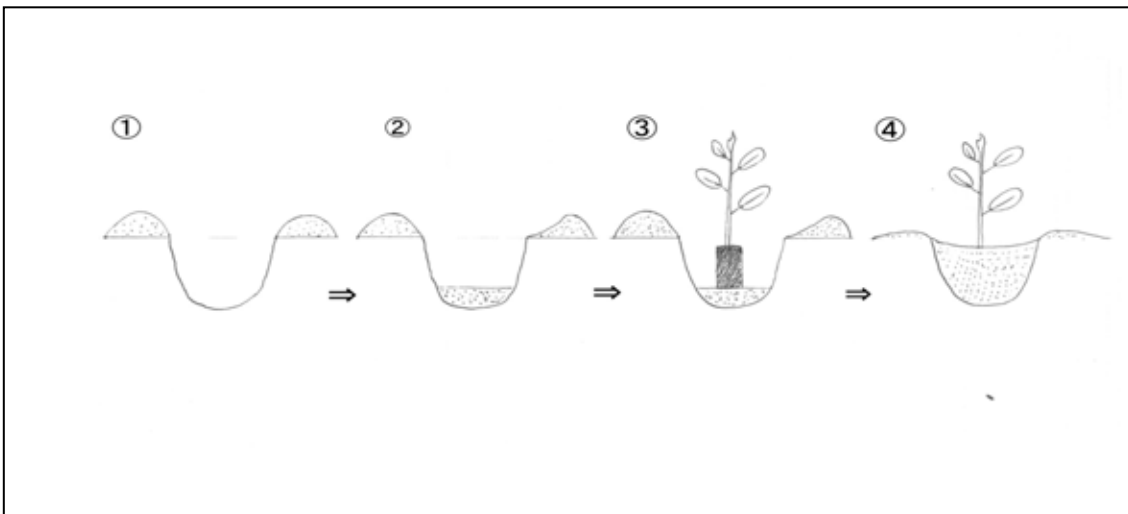

## **2.5 Construction of nurseries**

### **2.5.1 Site selection and design**

#### 1) Site selection

The site of nurseries should be carefully selected with some consideration mentioned below. Both physical and socio-economical aspects are considered.

##### a) Physical conditions necessary for the site of nurseries

- Easy access to water: watering is one of the heaviest duties among nursery works. For reducing such burden, nurseries should be located near water sources.
- Safe from natural disaster: irregular precipitation pattern with low water retentivity of soil often causes flooding and sedimentation in some areas. These areas should be avoided for the location of nurseries.
- Flat or gentle slope: as same as other outdoor works, working in flat ground is easier than that on slopes and it reduces the risk of accidents.

##### b) Socio-economic conditions

- Easy access from the residential area of workers: this condition increases the possibility of closer care of a nursery by workers.
- Easy access for consumers (or easy access to markets): nurseries should have and/or develop easier access to customers for promoting a market of products (seedlings).

#### 2) Design of nursery

After the decision of the site, ground design is drawn. The main items are the allocation of entrance and passages, nursery beds, and probably resting place. The amount of materials needed can be estimated from this design. The location and distance between poles should be carefully decided considering the length/width of beams and nets.



**Example of a plan of nursery**



**Example of allocation in a nursery**

**(Rusplass Nursery)**



**(Bulamahlo Nursery)**



## 2.5.2 Procurement of materials and equipment

### 1) Materials for building nursery

Materials and equipments necessary for constructing nursery are shown in the table below. The amount of materials needed depends on the size of nursery, which would be estimated during designing process. Then, the amount of money to be spent is calculated.

Besides those materials listed below, some materials for fencing might be required.

Name of materials	Unit	Quantity	Unit price	Amount
Treated pole (75mm, 4m long)	no			
Treated pole (75mm, 3m long)	no			
Treated pole (75mm, 2.4m long)	no			
Clamps	bag			
Nails	bag			
Cement	bag			
Shading net	roll			
Total	-	-	-	

### 2) Equipments and materials needed for running nursery

Some equipment and materials which might be necessary for running a nursery are listed below. Some of them are also utilized for construction. Each quantity should be estimated in accordance with a plan and their availability. Then, the amount of money to be spent is calculated.

Name of equipment	Unit	Quantity	Unit price	Amount
Polythene bag	no			
Fertilizer	bag			
Seeds of several species	no			
Wheel barrow	no			
Watering can	no			
Bucket	no			
Shovel	no			
Pick	no			
Hoe	no			
Small shovel	no			
Small rake	no			
Hammer	no			
Measuring tape (30m long)	no			
Saw	no			
Total	-	-	-	

**Poles**



**Beams and poles**



**Shading net**



## List of useful trees and shrubs in and around Sekhukhune

Name (Scientific)	Name (English)	Name (local)	Size	Main Usage	Growth Rate (maximum per year)	Propagation	Remarks
<i>Sclerocarya birrea</i>	Marula	Morula	Tree (up to 18m)	Fruits, nuts	Fast (1.5m)	Easy	Young trees are frost-sensitive, Sexes on separate trees, takes 8 years to bear fruits
<i>Mimusops zeyheri</i>	Transvaal red milkwood	Mmupudu	Tree (up to 15m)	Fruits	Moderate (80cm)		Evergreen, Frost tender
<i>Acacia tortilis</i>	Umbrella thorn	Mosu	Tree (up to 20m)	Fodder, Fuelwoods	Moderate (50-60cm)	Easy	
<i>Dovyalis caffra</i>	Kei-apple	Mothono	Tree (up to 9m)	Fruits, hedge	Moderate (60cm)		Evergreen, Frost tender when young
<i>Pertophorum africanum</i>	African wattle	Mosehla	Tree (up to 15m)	Fodder, timber, medicine, fuelwoods	Fast (1-1.5m)		Good for avenue trees, Frost sensitive in first two or three years
<i>Dombeya rotundifolia</i>	Wild pear	Mohlabaphala	Tree (up to 10m)	Fodder, furniture, timber, Fuelwoods	Fast (1.5m)	Easy (seeds and cuttings)	Good for avenue trees
<i>Rhus chirindensis</i>	Red currant	Monotlou	Tree (up to 20m)	Furniture, Fuelwoods	Fast (1m)	Easy (seeds and cuttings)	It takes 5-8 weeks for seeds to germinate
<i>Carissa edulis</i>	Simple-spined num-num	Mothokolo	Small tree or scrambler (up to 6m)	Hedge	Fast (1-1.2m)	Easy	Evergreen, Seedlings and young plants are frost tender
<i>Ehretia rigida</i>	Puzzle bush	Morobe	Tree (up to 9m)	Fodder, Fruits	Moderate (60-70cm)	Easy (seeds and cuttings)	
<i>Ficus burkei</i> ( <i>Ficus thonningii</i> )	Common wild fig	Mouno	Tree (up to 15m)	Shade, Fodder, Fruits	-	Easy (cutting)	Evergreen, Sensitive to cold winds
<i>Acacia caroo</i>	Sweet thorn	Mookana	Tree (up to 20m)	Fodder, apiculture	Fast (1m)	Easy	Evergreen
<i>Harpephyllum caffrum</i>	Wild plum	Mothekele	Tree (up to 20m)	Furniture, Timber, Fruits, medicine	Fast (1-1.5m)	Easy	Evergreen, Withstand light frost and short period of drought
<i>Rhus rancea</i>	Karee	Mokalabata	Tree (up to 9m)	Fodder, Fruits	Fairly fast (80cm)	Easy	Evergreen
<i>Bauhinia galpinii</i>	Pride of De Kaap	Motshwiriri	Small tree (Up to 5m)	Craft	-		Evergreen, Young plant must protect against frost for the first year
<i>Cassine transvaalensis</i>	Transvaal saffron		Shrub or small tree	Medicine, Fodder	-		
<i>Croton gratissimus</i>	Lavender fever-berry		Shrub or small tree	Cosmetics, Fodder	-		
<i>Dodonaea angustifolia</i>	Sand olive		Shrub or small tree	Medicine	-		one of the most important traditional medicine
<i>Euclea undulata</i>	Common guarri		Shrub or small tree	Medicine, Fodder	-		Evergreen
<i>Leonotis leonurus</i>			Shrub (?)	Medicine	-		
<i>Olea europaea</i>	Wild olive	Mohlware	Tree (up to 14m)	Medicine, Furniture, Craft, Fruits	Fairly fast (80cm)		Evergreen, Seedling must protect against cold winds for the first two years
<i>Schotia brachypetala</i>	Weeping boer-bean	Molope	Tree (up to 25m)	Medicine, Fodder	Fairly fast (70cm)		
<i>Ziziphus mucronata</i>	Buffalo thorn	Mokgalo	Tree (up to 17m)	Medicine, Fuelwoods, Fruits	Fast (1-1.5m)	Easy	
<i>Aloe spp.</i>	Aloe		Shrub or small tree	Medicine	-		Several species of aloe are used

Conditions to be considered: Drought resistant, Usefull, Fast growing, Easy to propagate, Indegenous in the region

References: Making the most of indegenous trees  
Field guide to trees of southern Africa

### 3. Monitoring and evaluation

#### 3.1 Monitoring of inputs and outputs

Monitoring means 1) to check the input and the progress of the work, 2) to measure the output and the performances of the work, periodically, and 3) to find out measures to be taken if there are any problems observed.

The outputs and the performances of the project are measured by the indicators indicated in the logical framework.

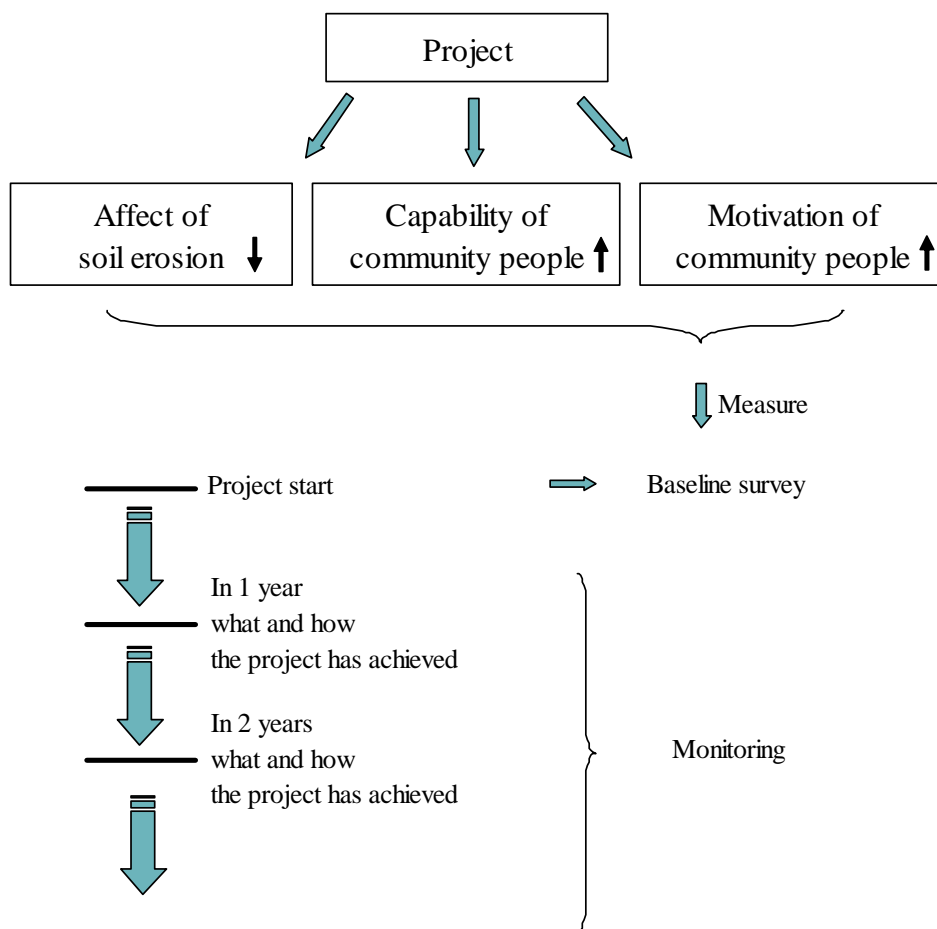

**Concept of the monitoring**

### Indicators for the monitoring from the logical framework

Project Summary	Indicators
<p><b>Overall Goal</b></p> <p>D) Impact of soil erosion is alleviated.</p> <p>E) Ability of the target communities to address soil erosion problems is improved.</p> <p>F) Ability of project staff to carry out soil conservation projects is enhanced.</p>	<p>D) Condition of soil erosion, floods, vegetation, area of land with farm crops and crop yields.</p> <p>E) Changes in awareness, initiative, technical knowledge and management skills.</p> <p>F) Changes in awareness, initiative, technical knowledge and management skills.</p>
<p><b>Project Purpose</b></p> <p>The soil conservation structures built in the project are maintained regularly and sustain their necessary functions.</p>	<p>Maintenance status, sustainability of functions of soil conservation structures, sustainability of maintenance system.</p>
<p><b>Output</b></p> <p>e) Soil conservation structures are completed.</p> <p>f) An implementation and monitoring system is built up on both LDA and community sides.</p> <p>g) Maintenance system is devised on both LDA and community sides.</p> <p>h) A model is established, including a standard design, a standard implementation process and a standard implementation system.</p>	<p>e) Functionality of soil conservation structures.</p> <p>f) Functionality of implementation and monitoring systems.</p> <p>g) Functionality of maintenance systems.</p> <p>h) Model's technical completion and effectiveness.</p>

### 3.2 Sample evaluation grid

Evaluation means 1) to evaluate the whole process and the performance of the project, and 2) to evaluate the results of the projects, in order to obtain lessons and other useful information for future projects and other similar projects. A sample evaluation grid is shown below:

Evaluation criteria	Sub-criteria	Indicator	Necessary Data	Data Collection	Summary of Evaluation Results
<b>Category A: Measuring outputs ( “Effectiveness” in the five evaluation criteria )</b>					
(A-1) Validity of the model	Design	Comparison with target values  Comparison with past examples	Evaluation results in Categories B and C	Reviewing evaluation results	
	Process  Organization /system	Comparison with target values  Comparison between pre-implementation and post-implementation  Comparison with past examples	Evaluation results in Categories B and C	Reviewing evaluation results	
<b>Category B: Measuring effectiveness ( “Effectiveness” and “Impact” in the five evaluation criteria )</b>					
(B-1) Functions of constructed structures	Turning flood into safe flow	Comparison with target values	Extent of impact of erosion	Observation	
	Prevention of further erosion				
(B-1) Functions of constructed structures	Promotion of vegetation recovery	Comparison with target values	Extent of vegetation recovery	Observation	
	Prevention of soil and water discharge				
(B-2) Improvement of agricultural production		Comparison between pre-implementation and post-implementation	Changes in amount of cultivated areas and harvest	Questionnaire	
(B-3) Communities’ capacity building		Comparison between pre-implementation and post-implementation	Changes in awareness, motivation, knowledge and capacity	Questionnaire Observation	
(B-4) Project staff’s capacity building		Comparison between	Changes in awareness,	Questionnaire Observation	

Evaluation criteria	Sub-criteria	Indicator	Necessary Data	Data Collection	Summary of Evaluation Results
		pre-implementation and post-implementation	motivation, knowledge and capacity		
(B-5) Economic effects/outcomes		Comparison with target values	Input, benefit, negative impact	Reviewing references on outcomes	
<b>Category C: Comparison with past examples ( “Efficiency”, “Effectiveness”, “Impact” and “Sustainability” in the five evaluation criteria )</b>					
(C-1) Comparison with past examples in terms of economical efficiency, sustainability and effects/outcomes	Efficiency	Comparison with past examples	Input, benefit, negative impact	<ul style="list-style-type: none"> <li>● Observation</li> <li>● Reviewing LDA references</li> </ul>	
	Sustainability	Comparison with past examples	Maintenance situation Whether structure functions are sustained Whether maintenance system is sustained	<ul style="list-style-type: none"> <li>● Observation</li> <li>● Reviewing LDA references</li> </ul>	
	Effects / outcomes	Comparison with past examples	Emergence of effects/outcomes	<ul style="list-style-type: none"> <li>● Observation</li> <li>● Reviewing LDA references</li> </ul>	



### 3.3 Sample form of evaluation

Sample questionnaires for the committee, the community and the project staff for evaluation of the motivation and the capacity building of them are shown below.

#### Sample questionnaire for committee and community for baseline and monitoring surveys

---

##### Interview to community people

– for small group ( male / female, under / over 30 years old )

##### I. Basic information

- 1) Date of interview: \_\_\_\_\_
- 2) Name of community: \_\_\_\_\_
- 3) Profile of interviewees:

Name	Age	Gender	Income source	Annual income
		M / F		
		M / F		
		M / F		
		M / F		
		M / F		

##### II. Agriculture

##### 1) Crop production

Name of farmer	Name of crop	Year	Area (ha)	Amount of harvest	Application of fertilizer, manure, chemicals, etc.	% of self-consumption / selling
						% / %
						% / %
						% / %
						% / %
						% / %
						% / %
						% / %
						% / %
						% / %
						% / %
						% / %
						% / %
						% / %
						% / %
						% / %
						% / %

- 2) Did you have any problems or damages due to inappropriate method of cultivation, e.g. cultivation in parallel with contours, cultivation in depression?

**III. Domestic animals**

1) Number of animals and area of pasturage

Name of farmer	Name of animal	Number of animal	Area of pasturage

2) Do you have any rules in grazing?

e.g. In whose land do you graze animals? – animal owner’s land, your kgosi’s land, other kgosi’s land, getting permission of kgosi or not?

Who controls grazing? – animal owner by him/herself or requesting other people

Any rules in the case of grazing in other people’s land or in other kgosi’s land?

**IV. Fuel wood gathering**

1) Species of plants: \_\_\_\_\_

2) Frequency of gathering: \_\_\_\_\_

3) Amount of gathering per household: \_\_\_\_\_

4) Amount of consumption per household: \_\_\_\_\_

**V. Plant species used for other purposes than fuel**

Species of plants	Purpose of usage	Amount of consumption



5) What have you achieved from your activities so far?

6) What have you not achieved from your activities so far?

7) How has your motivation for soil conservation activities changed?

8) What activities do you think are necessary in the future?

**Interview to committee members**

**I. Basic information**

- 1) Date of interview: \_\_\_\_\_
- 2) Name of community: \_\_\_\_\_
- 3) Name of interviewees:

Name	Position	Age	Gender
			M / F
			M / F
			M / F
			M / F
			M / F
			M / F
			M / F
			M / F
			M / F

**II. Situation of committee meeting in July to November 2004**

- 1) How often have you had committee meetings on the soil conservation project?
  
  
  
  
  
  
  
  
  
  
- 2) What was the contents of committee meetings? Give us examples.
  
  
  
  
  
  
  
  
  
  
- 3) What was the decisions made in committee meetings? Give us examples.
  
  
  
  
  
  
  
  
  
  
- 4) Have you kept records of the results of committee meetings? If yes, who keeps records, and what is recorded in committee meetings, e.g. date, name of participants, agenda, conclusions?

- 5) How did you inform community people of the results of committee meetings?

### **III. Situation of mass meeting with community people in July to November 2004**

- 1) Have you had mass meetings with community people on the soil conservation project? If yes, how often?
  
  
  
  
  
  
  
  
  
  
- 2) How is the number of participants in mass meetings?
  
  
  
  
  
  
  
  
  
  
- 3) What was the contents of mass meetings? Give us examples.
  
  
  
  
  
  
  
  
  
  
- 4) What was the decisions made in mass meetings? Give us examples.
  
  
  
  
  
  
  
  
  
  
- 5) Have you kept records of the results of mass meetings? If yes, who keeps records, and what is recorded in mass meetings, e.g. date, number of participants, name of participants, agenda, conclusions?

**IV. Situation of rules of committee and community**

- 1) Do you have a written constitution? yes / no
- 2) If yes, does the constitution stipulate the followings?
  - (a) purpose of committee yes / no
  - (b) role of persons yes / no
  - (c) process of decision making, communication and action yes / no

**Sample questionnaire for project staff members for baseline and monitoring surveys**

---

**Questionnaire for the project staff**

Please answer the following questions after discussing among the staff members.

**1. What are the advantages and the disadvantages in the following aspects of the activities in these two years?**

Aspect	Advantages	Disadvantages
Arrangements of activities		
Communication with target communities and/or committees		



Communication among staff members		
-----------------------------------	--	--

**2. What are the success and the failure in the activities in these two years?**

Success	
Failure	

**3. What did you learn from the activities in these two years?**

--

**4. How have your awareness and skills changed in these two years?**

Awareness of importance and necessity of soil conservation	
--	--

Technical knowledge and skills on soil conservation projects	
Management skills for project implementation	

**5. Would you like to participate in other community soil conservation projects or other type of projects in the future? What type of projects would you like to participate in in the future?**

A large, empty rectangular box with a thin black border, intended for a written response.

**6. In case you participate in other projects in the future, how are you going to utilize your experiences of these two years?**

A large, empty rectangular box with a thin black border, intended for a written response.

**Limpopo Province  
Republic of South Africa**

**Maintenance Manual  
for  
Target Communities  
of  
Community Soil Conservation Program**

**March 2007**

**Limpopo Province Department of Agriculture**

**JICA Study Team**

**For the Study on the Integrated Holistic Rural Development  
and Soil Conservation Programme in Schoonoord Area,  
Sekhukhune District, Limpopo Province  
in Republic of South Africa**

**Maintenance Manual for Target Communities  
of Community Soil Conservation Program**

**Table of Contents**

1. <i>Understanding of the project</i>	-----	1
2. <i>Maintenance of planted trees and grasses</i>	-----	3
2.1 <i>Conditions and functions to be targeted</i>	-----	3
2.2 <i>Required aftercare (1) – Treating planted trees and grasses</i>	-	4
2.3 <i>Required aftercare (2) – Replanting vetiver grasses</i>	-----	5
2.4 <i>Required aftercare (3) – Replanting tree seedlings</i>	-----	6
3. <i>Method of cultivation</i>	-----	7
3.1 <i>Practices prohibited and recommended</i>	-----	7
3.2 <i>Good land use</i>	-----	8

## **1. Understanding of the project**

The project consists of the following basic components, which are expected to produce synergic effects.

### **a. Construction work**

Damage caused by floods and soil runoffs is minimized and erosion aggravation is prevented through the construction of storm water banks, waterways, and contours. In addition, waterways are protected from flood-caused erosion through the construction of waterway protection structures.

Storm water banks catch the flood flow from the mountain side, leading the flow into waterways. Also, contours catch the rain water inside the target area, leading it into waterways. Thus, the flood flows downwards safely

### **b. Planting work**

Storm water banks, contours, waterways and other structures are protected from flood-caused erosion through forestation and planting. In order to secure long-term continuity of these activities, local people's awareness of the need for environment protection is raised through their participation in forestation and planting works.

### **c. Fencing work**

Fences are built in order to protect the vegetation from cattle and to contribute to its recovery.

### **d. Nursery work (optional)**

Construction works for tree nurseries may be added optionally when target communities wish to produce seedlings as a way of contributing to soil conservation and greening activities in neighboring areas, or as a way of earning additional income.

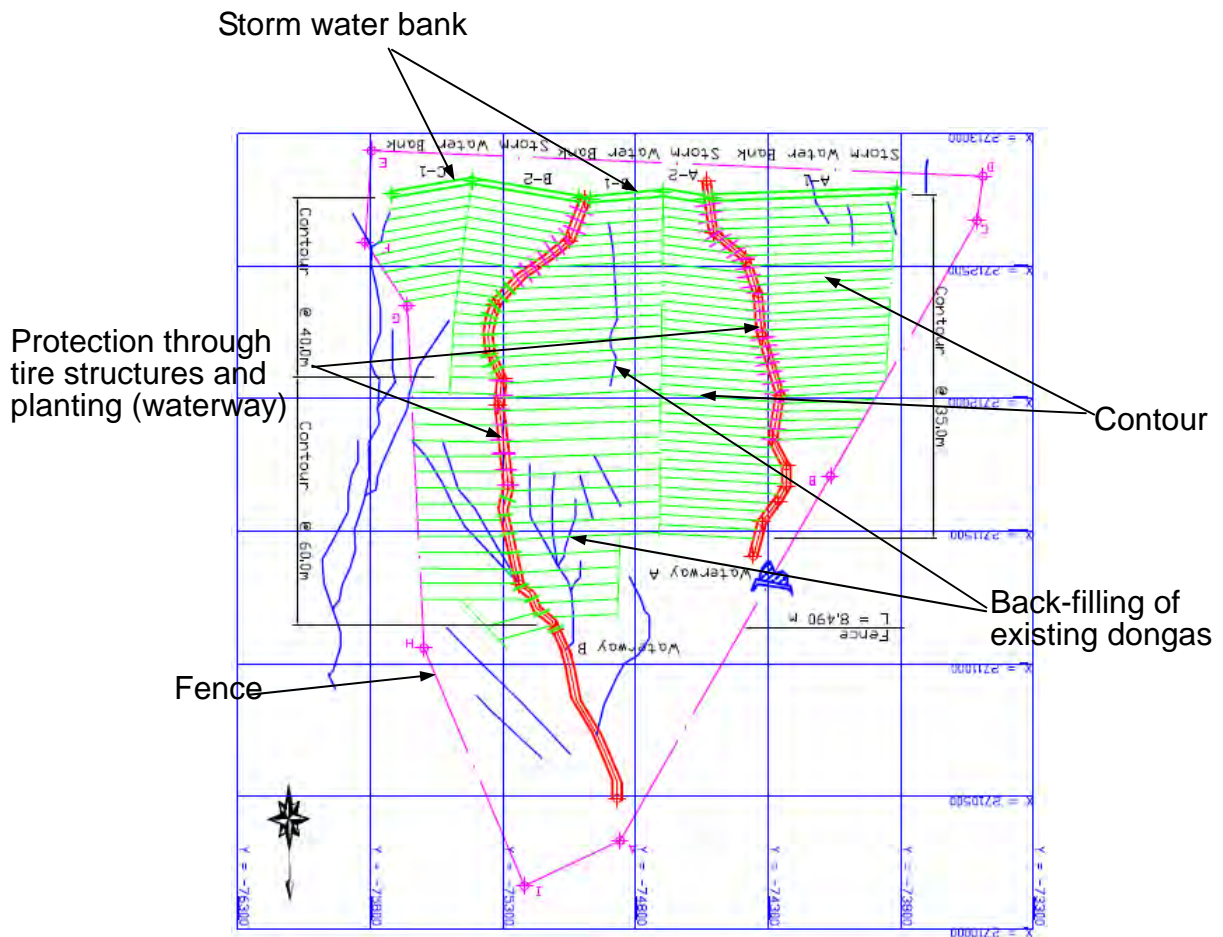

Typical layout plan of the project



## 2. Maintenance of planted trees and grasses

### 2.1 Conditions and functions to be targeted

Planted trees and grasses are expected to work for protecting soil against erosion. However, this function does not take effect immediately. We need to raise those plants carefully until they form continuous hedgerows illustrated below.

#### Effective tree lines and grass hedges against soil erosion

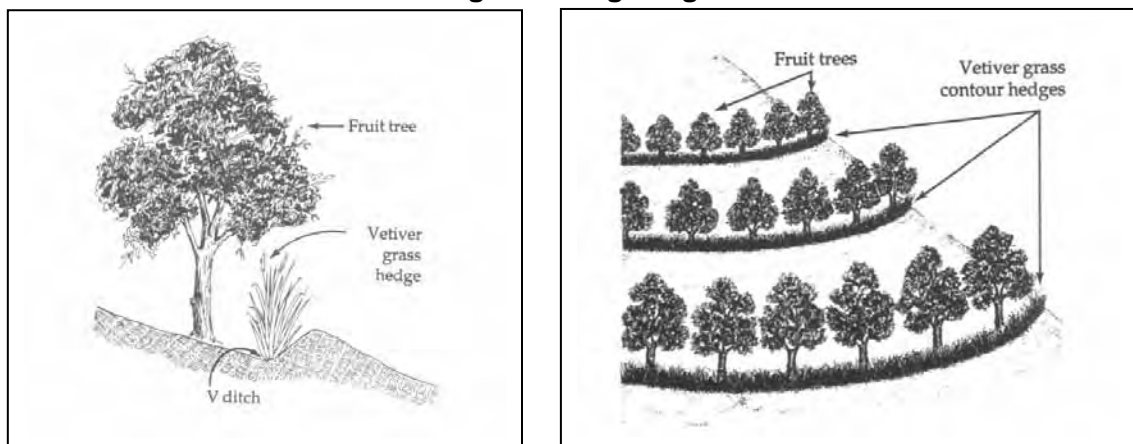

(Source: Vetiver grass (World bank; 1990, ISBN 0-8213-1405-X) )

## 2.2 Required aftercare (1) – Treating planted trees and grasses

For raising those plants well, we need some aftercare works as follows.

- Watering
- Putting fertilizer
- Controlling grazing
- Controlling bush fire
- Patrolling

We need some tools for carrying out the maintenance works. Those tools and materials listed below are basic lineup which might be used for maintenance works of planted trees and grasses.

<b>Name of tools and materials</b>	<b>Unit price</b>
Water tank (JoJo tank) (0.5 ton)	R1,300.00
A set of connecting parts on tank	R120.00
Thick watering hose with 30m long	R585.00
Concrete bucket	R70.00
Shovel	R60.00
Watering can	R23.00
Panga	R16.00
Seedling (for replanting)	R10.00

### 2.3 Required aftercare (2) – Replanting vetiver grasses

If planted grasses dried up, we need to replace them. Ideally, this activity should be carried out at the beginning of rainy season.

**Vetiver grass:** Before transplanting, cut the top of each slip off about 15-20 centimeters above the base, and roots 10 centimeters below the base (see illustrations below). When planting, make a hole at first. Push the slip into the hole, taking care not to bend the roots upward. Then, firm the slip in the soil. Watering is sometimes required just after planting if the ground moisture seems to be low.

#### Preparation of vetiver slips

1



2



3

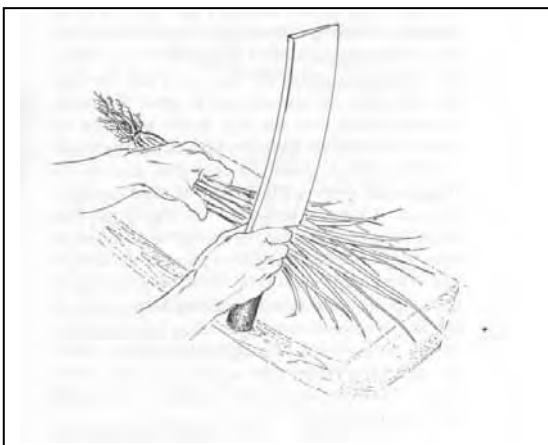

4

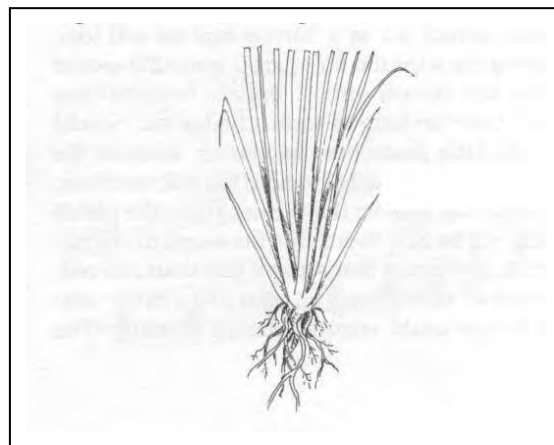

## 2.4 Required aftercare (3) – Replanting tree seedlings

If planted trees dried up, we need to replace them. Ideally, this activity should be carried out at the beginning of rainy season.

### Digging planting pit

- Dig a pit for planting tree. The size should be 40cm×40cm in length and 40cm in depth in minimum case. ( )
- Fill up a pit with dug up soil a little, to provide soft soil even underneath of seedling's roots. ( )

### Planting a seedling

- Dip a seedling with plastic bag into water and soak water into its soil.
- Cut and open one side of a plastic bag and remove it from soil “cylinder”.
- Place a seedling with soil “cylinder” at the center bottom of a planting pit. ( )
- Fill up a pit with soil to the height of collar region (the base of a seedling stem), and compact the soil. ( )
- Give bucketful water (about 15 liters) to the planted “basin”.

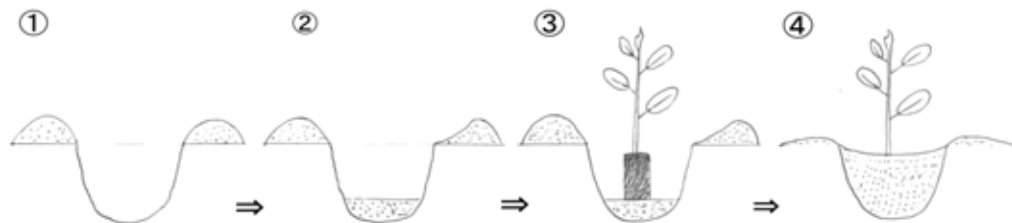

### Aftercare for planted seedlings

- If tree seedlings are planted in dry season, give bucketful water to the planted seedling once a week when it's hot, or twice a month when it's not so hot for about four to six month until plant is fully established.

**If seedlings are not planted soon**, those seedlings must be put under shade and give water daily. Otherwise those seedlings will die before long.

### 3. Method of cultivation

#### 3.1 Practices prohibited and recommended

By plowing just straight up and down the slope one farmer (illustrated above) is encouraging the rainfall to run off his farm, taking irreplaceable layer of topsoil away. The rainwater runs off so quickly it does not have a chance to soak into the soil.

The other farmer (illustrated below) has protected his land against soil erosion by planting vegetative hedges on the contour and using the hedgerows as guidelines to plow and plant on the contour. The furrows will hold rainfall and store extra moisture in the soil.

#### Two ways of cultivation

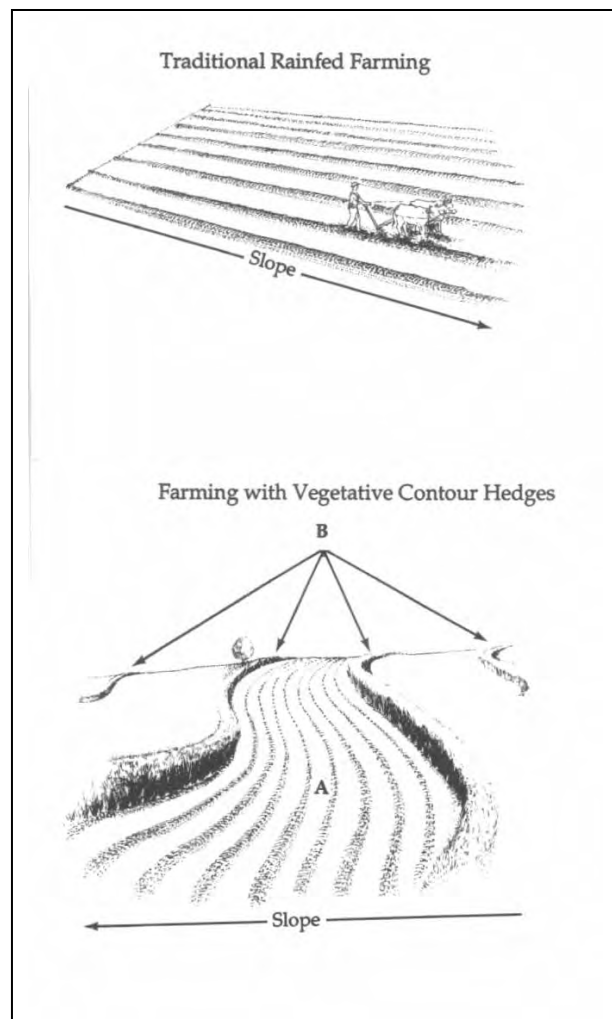

(Source: Vetiver grass (World bank; 1990, ISBN 0-8213-1405-X) )

### 3.2 Good land use

A: All suitable arable land which is cultivated must be cultivated by using contour planting ridges.

B: The fairly steep slopes must only be utilized for grazing or tree plantation.

C: We must maintain grass cover over our steep slopes and we must prevent the grass from over grazing.

#### Good land use

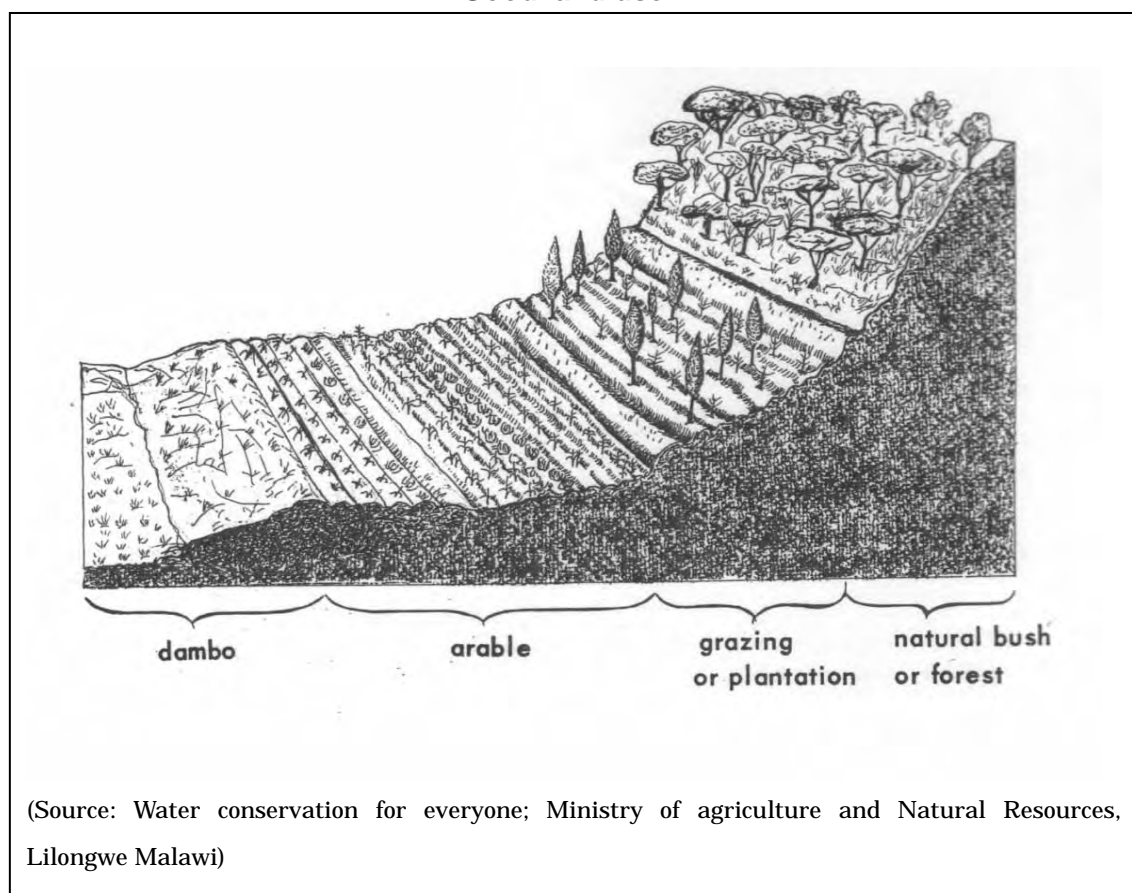

## 5 . センターオブエクセレンス・プロジェクト ( CEP ) のワークブレイクダウンストラクチャー ( WBS )

Work Breakdown Structure for the Center of Excellence Project (WBS/CEP)

	1st Level	2nd Level
<b>1 SMALL AGRICULTURE</b>	<b>1.1 School Training of Farmers</b>	1.1.1 Training Plan at TAC
		1.1.2 Invitation of Applicants
		1.1.3 Training at TAC
	<b>1.2 Initial Farm Support</b>	1.2.1 On-farm Appraisal
		1.2.2 Material Support
	<b>1.3 On-Farm Consultation</b>	1.3.1 On-farm Consultation
	<b>1.4 Officials Training</b>	1.4.1 Plan of Officials Training
		1.4.2 Training Implementation
<b>2 LIVESTOCK PRODUCTION</b>	<b>2.1 School Training of Farmers</b>	2.1.1 Training Plan at TAC
		2.1.2 Invitation of Group Applications
		2.1.3 Training at TAC
	<b>2.2 Initial Group Support</b>	2.2.1 Group Needs Appraisal
		2.2.2 Material Support
	<b>2.3 On-Farm Consultation</b>	2.3.1 On-farm Consultation
	<b>2.4 Training of Officials</b>	2.4.1 Plan of Officials Training
		2.4.2 Training Implementation
<b>3 COMMUNITY CONSERVATION</b>	<b>3.1 Community Nursery</b>	3.1.1 Implementation Plan
		3.1.2 Invitation of Group Applications
		3.1.3 Field Visit
		3.1.4 Group Needs Assessment
		3.1.5 Group Support
	<b>3.2 Community Forest</b>	3.2.1 Social Preparation
		3.2.2 Construction of Forest
<b>4 OTHER ACTIVITIES</b>	<b>4.1 Micro-Credit</b>	4.1.1 Implementation Plan
		4.1.2 Lending
		4.1.3 Other Activities



**1 SMALL AGRICULTURE**

1st Level	2nd Level	3rd Level		Output	Prpgress (%)	Person in charge	Starting Date	Deadline	Super- vison by	Budgets	
<b>1.1 School Training of Farmers</b>	1.1.1 Training Plan at TAC	1.1.1.1	Working out a draft training plan	Draft plan	3						
		1.1.1.2	Finalizing the training plan	Final plan	1						
		5 1.1.1.3	Informing the training plan to relevant sections	Memorandum	1						
	20 1.1.2 Invitation of Applicants	1.1.2.1	Printing pamphlet with application format	Pamphlet	1						
		1.1.2.2	Distributing to Municipality and LDA offices	Distribution	1						
		5 1.1.2.3	Holding seminars for potential applicants	Seminars	1						
		1.1.2.4	Receiving applications	Applications	1						
		1.1.2.5	Screening applicants	Report	1						
	1.1.3 Training at TAC	1.1.3.1	Arranging transportation & lodges for trainees	Ride/Lodge	1						
		1.1.3.2	Implementing training courses for 2 weeks	Training	3						
		10 1.1.3.3	Visiting excellent small farms	Visit	3						
		1.1.3.4	Evaluating trainees and trainers	Evaluation Report	2						
		1.1.3.5	Accepting application for initial farm support	Applications	1						
	<b>1.2 Initial Farm Support</b>	1.2.1 On-farm Appraisal	1.2.1.1	Selecting applicants	Report	1					
			1.2.1.2	Assessing support needs with individual reports	Appraisal Report	2					
4 1.2.1.3			Approving appraisal reports	Approval	1						
10 1.2.2 Material Support		1.2.2.1	Delivering materials	Delivered materials	2						
		6 1.2.2.2	Assisting setting up farm	Farms set up	4						
<b>1.3 On-Farm Consultation</b>	1.3.1 On-farm Consultation	1.3.1.1	Visiting regularly for technical assistance (TA)	TA	24						
		1.3.1.2	Farmer-to-farmer training at excellent farms	TA	24						
		50 1.3.1.3	Preparing the end-of-the-year report	Report	2						
<b>1.4 Officials Training</b>	20 1.4.1 Plan of Officials Training	1.4.1.1	Profiling of poteintial trainees (taring needs assessment)	Draft Plan	3						
		1.4.1.2	Working out a draft training plan	Draft Plan	3						
		10 1.4.1.3	Finalizing the training plan	Final Plan	1						
		1.4.1.4	Informing the training plan to relevant sections	Memorandum	1						
		1.4.1.5	Accepting applicants	Applications	1						
		1.4.1.6	Selection of trainees		1						
	1.4.2 Training Implementation	1.4.2.1	Implementing training for 4 days	Training	5						
1.4.2.2		Preparing individual action plans after training	Action Plans	3							
10 1.4.2.3		Evaluating trainees and trainers	Evaluation Report	2							

Total 100 %

Total RSA

1st Level	2nd Level	3rd Level	4th Level		Output	Progress (%)	Person in charge	Starting Date	Deadline	Supervision by	Budgets
<b>1.2 Initial Farm Support</b>	1.2.1 On-farm Appraisal	1.2.1.1	Selecting applicants		Report						
		1.2.1.2	Assessing support needs with individual reports		Appraisal Report						
		1.2.1.3	Approving appraisal reports		Approval						
	1.2.2 Material Support	1.2.2.1 Delivering materials	1.2.2.1.1	Ordering chicks to ARC	Order						
			1.2.2.1.2	Collecting quotations for other materials	Quotations						
			1.2.2.1.3	Approving procurement documents	Approval						
			1.2.2.1.4	Ordering other materials	Order						
			1.2.2.1.5	Delivering fencing materials	Delivered materials						
			1.2.2.1.6	Delivering seedling nursery materials	Delivered materials						
			1.2.2.1.7	Delivering chicken shed materials	Delivered materials						
			1.2.2.1.8	Delivering silage & earthworm prod. materials	Delivered materials						
			1.2.2.1.9	Delivering molinga seedlings	Delivered seedlings						
			1.2.2.1.10	Delivering chicks	Delivered chicks						
		1.2.2.2 Assisting setting up farm	1.2.2.2.1	Monitoring fencing	Fence						
			1.2.2.2.2	Monitoring and assisting composting	Compost						
			1.2.2.2.3	Monitoring and seedling nursery construction	Seedling nursery						
			1.2.2.2.4	Monitoring chicken shed construction	Chicken shed						
1.2.2.2.5	Monitoring earthworm bed construction		Earthworm bed								
1.2.2.2.6	Monitoring molinga seedling planting		Planted Molinga								
1.2.2.2.7	Monitoring silage production		Silage								
<b>1.3 On-Farm Consultation</b>	1.3.1 On-farm Consultation	1.3.1.1 Visiting regularly for technical assistance (TA)	1.3.1.1.1	Monitoring and assisting seedling production	Vege seedlings						
			1.3.1.1.2	Monitoring and assisting earthworm culture	Earthworms						
			1.3.1.1.3	Monitoring and assisting chicken rearing	Chickens						
			1.3.1.1.4	Assisting ND vaccination every 3 months	Vaccinated chickens						
			1.3.1.1.5	Monitoring and assisting vegetable production	Vegetables						
			1.3.1.1.6	Assisting vegetable and chicken marketing	Sales						
			1.3.1.1.7	Collecting production and marketing record twice a year	Record						
	1.3.1.2 Farmer-to-farmer training at excellent farms	1.3.1.2.1	Planning farmer-to-farmer training program	Program							
		1.3.1.2.2	Arranging transport, food and accommodation	Arrangement							
		1.3.1.2.3	Implementing farmer-to-farmer training program	Training							
		1.3.1.2.4	Evaluating farmer-to-farmer training program	Evaluation report							
1.3.1.3	Preparing the end-of-the-year report		Report								

**2 LIVESTOCK PRODUCTION**

1st Level	2nd Level	3rd Level	Output	Progress (%)	Person in charge	Starting Date	Deadline	Super- vision by	Budgets	
<b>2.1 School Training of Farmers</b>	2.1.1 Training Plan at TAC	2.1.1.1	Working out a draft training plan	Draft plan	3					
		2.1.1.2	Finalizing the training plan	Final plan	1					
		5 2.1.1.3	Informing the training plan to relevant sections	Memorandum	1					
	20 2.1.2 Invitation of Group Applications	2.1.2.1	Printing pamphlet with application format	Pamphlet	1					
		2.1.2.2	Distributing to Municipality and LDA offices	Distribution	1					
		2.1.2.3	Holding village seminars for potential applicants	Seminars	1					
		5 2.1.2.4	Receiving group applications	Applications	1					
		2.1.2.5	Screening group applications	Report	1					
	2.1.3 Training at TAC	2.1.3.1	Arranging transportation and lodges for trainees	Ride/Lodge	1					
		2.1.3.2	Implementing training courses for 2 weeks	Training	3					
		10 2.1.3.3	Visiting excellent livestock groups	Visit	3					
		2.1.3.4	Evaluating trainees and trainers	Evaluation Report	2					
		2.1.3.5	Accepting application for initial group support	Applications	1					
	<b>2.2 Initial Group Support</b>	2.2.1 Group Needs Appraisal	2.2.1.1	Criteria for village selection	Criteria	2				
			2.2.1.2	Selection and identification of villages	Identified villages	3				
30 2.2.1.3			Awareness creation and community mobilisation	Mobilization	7					
2.2.1.4			Approval from tribal authority	Approval	3					
2.2.1.5			Formation of interest groups	Formation	10					
2.2.1.6			Assesing support needs with individual groups	Assessment	2					
2.2.1.7			Approving appraisal reports	Approval	1					
2.2.1.8			Establish collaboration with other programmes(CASP)	Collaboration	2					
2.2.2 Material Support		2.2.2.1	Delivering materials	Delivered materials	2					
		5 2.2.2.2	Assisting setting up group facilities	Facility set up	3					
<b>2.3 On-Farm Consultation</b>	2.3.1 On-farm Consultation	2.3.1.1	Visiting regularly for technical assistance (TA)	TA	20					
		2.3.1.2	Farmer-to-farmer training at excellent groups	TA	4					
		25 2.3.1.3	Preparing the end-of-the-year report	Report	1					
<b>2.4 Officials Training</b>	1.4.1 Plan of Officials Training	1.4.1.1	Profiling of poteintial trainees (taring needs assessment)	Draft Plan	3					
		1.4.1.2	Working out a draft training plan	Draft Plan	3					
		10 1.4.1.3	Finalizing the training plan	Final Plan	1					
		1.4.1.4	Informing the training plan to relevant sections	Memorandum	1					
		1.4.1.5	Accepting applicants	Applications	1					
		1.4.1.6	Selection of trainees		1					
	1.4.2 Training Implementation	1.4.2.1	Implementing training for 4 days	Training	5					
		1.4.2.2	Preparing individual action plans after training	Action Plans	3					
		10 1.4.2.3	Evaluating trainees and trainers	Evaluation Report	2					

Total 100%

Total RSA

b	2nd Level	3rd Level		4th Level		Output	Progress (%)	Person in charge	Starting Date	Deadline	Supervision by	Budgets
<b>2.2 Initial group support</b>	2.2.1 Groups Needs Appraisal	2.2.1.1	Criteria for village selection		Criteria							
		2.2.1.2	Selection and identification of villages		Identified villages							
		2.2.1.3	Awareness creation and community mobilisation		Mobilization							
		2.2.1.4	Approval from tribal authority		Approval							
		2.2.1.5	Formation of interest groups		Formation							
		2.2.1.6	Assesing support needs with individual groups		Assessment							
		2.2.1.7	Approving appraisal reports		Approval							
		2.2.1.8	Establish collaboration with other programmes(CASP)		Collaboration							
	2.2.2 Material Support	2.2.2.1 Delivering materials	2.2.2.1.1	Quantity survey	Order							
			2.2.2.1.2	Purchasing procedure	Quotations							
			2.2.2.1.3	Delivering of material	Approval							
			2.2.2.1.4	Construction of facilities	Order							
		2.2.2.2 Assisting setting up group facilities	2.2.2.2.1	Technical capacity building	Fence							
			2.2.2.2.2	Monitoring and assisting with construction	Compost							
2.2.2.2.3	Social mobilisation for collective utilisation		Seedling nursery									
<b>2.3 On-Farm Consultation</b>	2.3.1 On-farm Consultation	2.3.1.1 Visiting regularly for technical assistance (TA)	2.3.1.1.1	Principles rangeland management	Vege seedlings							
			2.3.1.1.2	Implementation rangeland management	Earthworms							
			2.3.1.1.3	Practical problem solving	Chickens							
			2.3.1.1.4	Demonstration of benefits	Vaccinated chickens							
			2.3.1.1.5	Reflection and replanning	Vegetables							
		2.3.1.2 Farmer-to-farmer training at excellent farms	2.3.1.2.1	Identification of collaborators	Program							
			2.3.1.2.2	Logistical arrangements	Arrangement							
			2.3.1.2.3	Implementation of training programme	Training							
			2.3.1.2.4	Reflection and replanning	Evaluation report							
		2.3.1.3	Preparing the end-of-the-year report		Report							

3 COMMUNITY CONSERVATION

1st Level	2nd Level	3rd Level		Output	Progress (%)	Person in charge	Starting Date	Deadline	Supervision by	Budgets
<b>3.1 Community Nursery</b>	3.1.1 Implementation Plan	3.1.1.1	Working out a detailed draft implementation plan	Draft plan	4					
		5 3.1.1.2	Finalizing the a detailed implementation plan	Final plan	1					
	65 3.1.2 Invitation of Group Applications	3.1.2.1	Printing pamphlet with application format	Pamphlet	1					
		3.1.2.2	Distributing to Municipality and LDA offices	Distribution	1					
		3.1.2.3	Holding village seminars for potential applicants	Seminars	1					
		6 3.1.2.4	Receiving group applications	Applications	1					
		3.1.2.5	Screening group applications	Report	2					
	3.1.3 Field Visit	3.1.3.1	Visiting excellent conservation groups	Visit	4					
		5 3.1.3.2	Accepting application for initial group support	Applications	1					
	3.1.4 Group Needs Assessment	3.1.4.1	Selecting group application	Selection Report	2					
		3.1.4.2	Appraising support needs of individual groups	Appraisal Report	3					
		6 3.1.4.3	Approving appraisal reports	Approval	1					
	3.1.5 Group Support	3.1.5.1	Delivering materials	Delivered materials	2					
		43 3.1.5.2	Assisting setting up group facilities	Facility set up	10					
		3.1.5.3	Visiting regularly for technical assistance (TA)	TA	30					
3.1.5.4		Preparing the-end-of-year report	Report	1						
<b>3.2 Community Forest</b>	3.2.1 Social Preparation	3.2.1.1	Discussing with community leaders	Consensus	2					
		22 3.2.1.2	Holding community meeting for forest management	Consensus	20					
	35 3.2.2 Construction of Forest	3.2.1.3	Constructing community forest	Forest	3					
		13 3.2.1.4	Visiting Regularly for TA	TA	10					

Total 100%

Total RSA

4 OTHER ACTIVITIES

1st Level	2nd Level	3rd Level		Output	Progress (%)	Person in charge	Starting Date	Deadline	Super- vision by	Budgets
<b>4.1 Micro-Credit</b>  <b>100</b>	4.1.1 Implementation  Plan	41	4.1.1.1	Discussing with NGOs engaging micro-credit	Consensus	20				
			4.1.1.2	Assessing credit needs among CEP beneficiaries	Report	10				
			4.1.1.3	Working out a detailed draft implementation plan	Draft plan	10				
			4.1.1.4	Finalizing the a detailed implementation plan	Final plan	1				
	4.1.2 Lending	52	4.1.2.1	Holding village seminars for potential applicants	Seminars	5				
			4.1.2.2	Receiving applications	Applications	2				
			4.1.2.3	Lending credit	Credit	5				
			4.1.2.4	Monitoring Borrower Enterprises	Report	40				
	4.1.3 Other Activities	7	4.1.3.1	Visiting excellent borrower groups	Visit	5				
			4.1.3.2	Preparing the-end-of-year report	Report	2				

Total	100%
-------	------

Total	
-------	--

RSA