

Example of TEPCO

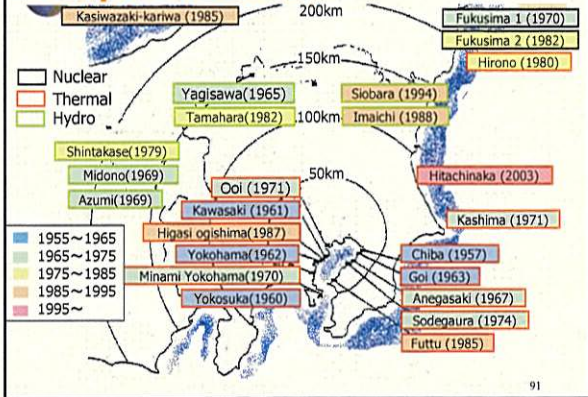

91

Location of Power Stations

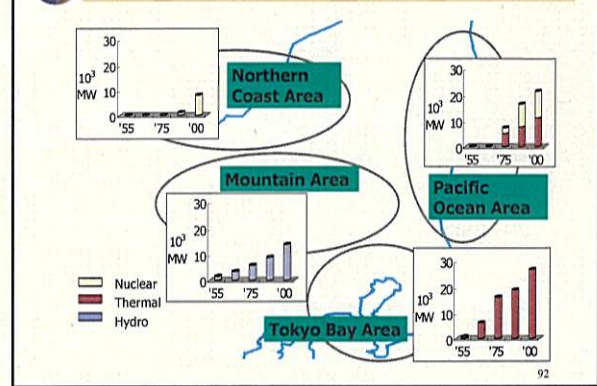

92

TEPCO's Transmission System Developments

Year	Social Events	Maximum Demand	Transmission System Development	
			Bulk Transmission	Metropolitan Supply
1955		2.6 GW	154kV	66kV
1960		4.8 GW		
1965	The Olympic Games	8.4 GW	275kV	154kV
1970		15.7 GW		
1975	Oil Crisis	23.0 GW		
1980	Oil Crisis	28.3 GW		
1985		36.8 GW	500kV	275kV
1990		49.3 GW		
1995		58.7 GW		
2000		59.2 GW		500kV
2005				

93

1955 (2.6GW)

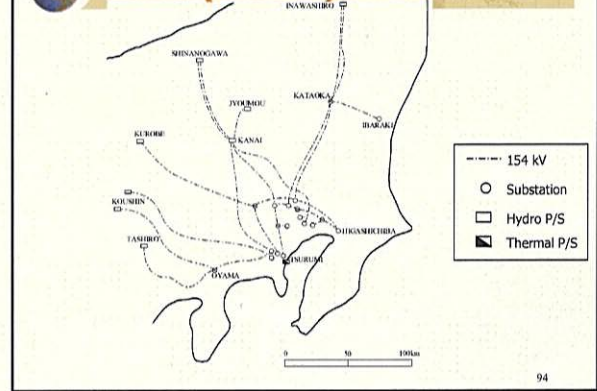

94

1965 (8.4GW)

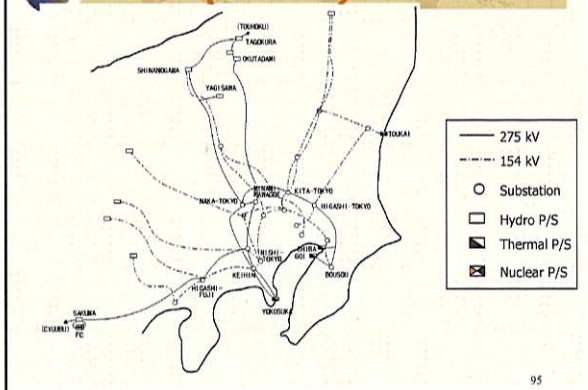

95

1975 (23GW)

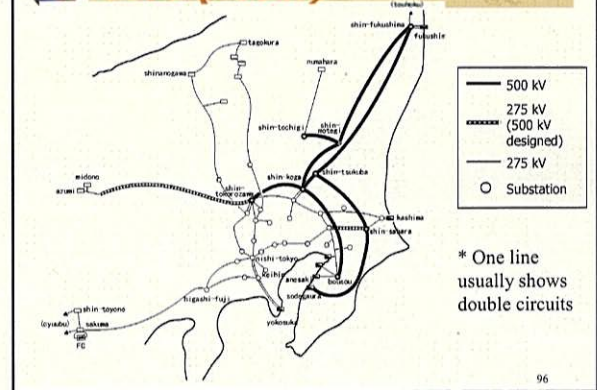

96

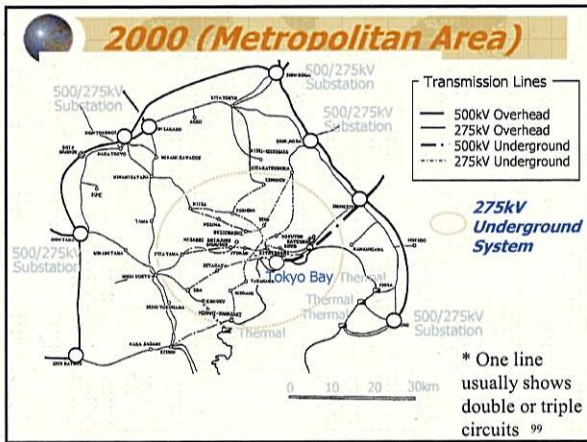
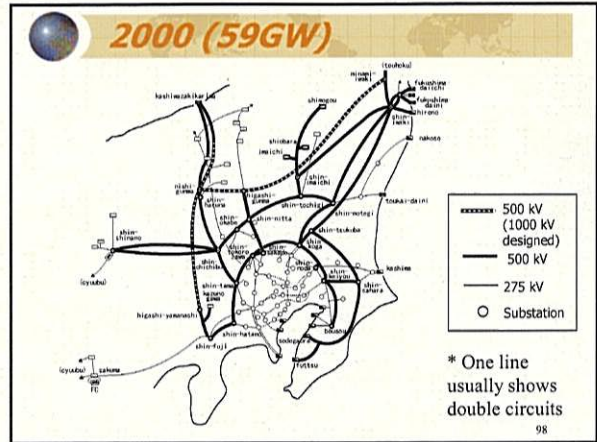
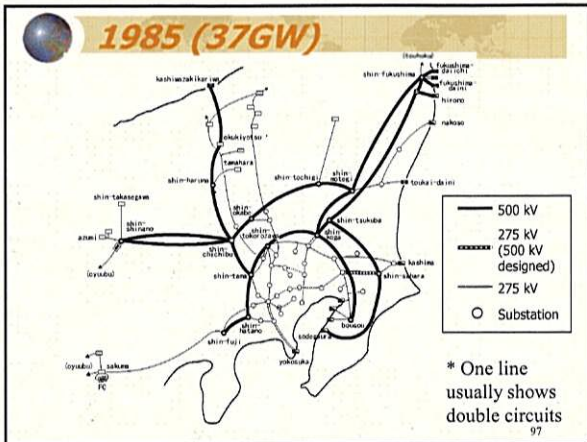

Standard Conductor

TEPCO

Voltage (kV)	Type	Number of Conductors
500	410, 610, 810	4, 6
	1,520	4
275	410, 610, 810, 1520	2, 4

EVN planning applied in the 6th MP

Voltage (kV)	Type	Number of Conductors
500	410, 610	4
220	610, 810	2

100

Standard Substation

TEPCO

Voltage	Capacity	Number of Transformers at final stage
500/275	1,500 (1,000)	4
500/154	750	4
275/154	450 (300)	4
275/66	300 (200)	4
154/66	200 (100)	4

EVN planning applied in the 6th MP

Voltage (kV)	Capacity	Number of Transformers
500/220	900, 600, 450	1-3
220/110	250, 125, 63	1-3

101

Countermeasures Against Increases in Fault Current

- Split operation of the system
 - Example

- Adopting the circuit breakers with high fault breaking ability
 - 63 KA
- Application of high impedance transformers
 - TEPCO 500 kV usually 14 % but high case 23%

102



From North to C & S in Vietnam

- ❖ Choice of location of power plants
 - ❑ Transmission lines reinforced or not
 - ❑ Power generation patterns limited or not
 - ❑ Power loss
 - The power loss from north to south can reach about 10% at most and about 6% on the average

103



From Center to South in Vietnam

- ❖ Nuclear power plants Center regions
- ❖ Coal thermal power plants
- ❖ Power import from large hydro power plants in Laos



- ❖ **Much reinforcement of 500 kV transmission lines required from center to south**

104



Higher Voltage Transmission Lines

- ❖ In Japan, when the large reinforcement of 500 kV system with many circuits was predicted for the future, the introduction of 1,000 kV system was examined for economical system configuration because of reducing the route of the lines
 - ❑ Now in china, 1000 kV AC transmission system is also considered
- ❖ For future Vietnamese network system, it would be valued to study such an alternatives if high scenario about power generation development in center to south

105



Voltage Maintenance

- ❖ Difficult to be adjusted only by static reactive power sources
- ❖ Automatic reactive power sources controllers will be required such as automatic switching operation of capacitors or shunt reactors and SVC (Thyristor controlling reactive power sources) or synchronous condensers
 - ❑ The annual planning of reactive power sources is preferable
 - ❑ Reactive power compensator for the 500 kV transmission lines

106



Series Capacitors

- ❖ Installation of series capacitors causes electrical series resonance with low frequency levels. When the frequency becomes equal to the frequency of turbine mechanical resonance of nuclear power plants or thermal power plants, power generators would vibrate and have a possibility of dropping from the system and causing black out. If many series capacitors are installed, it would be difficult to grasp the resonance frequencies.
- ❖ The installation of series capacitors should be limited in such a case of north – south transmission lines.

107



EVN Power Network Planning

- ❖ Regional power supply/demand balance
- ❖ Application of larger size facilities in/around Ho Chi Min City
- ❖ N-1 criteria
 - ❑ Power system analysis

108

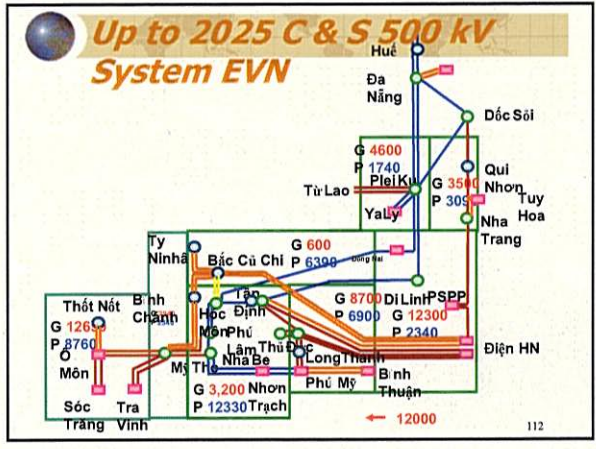
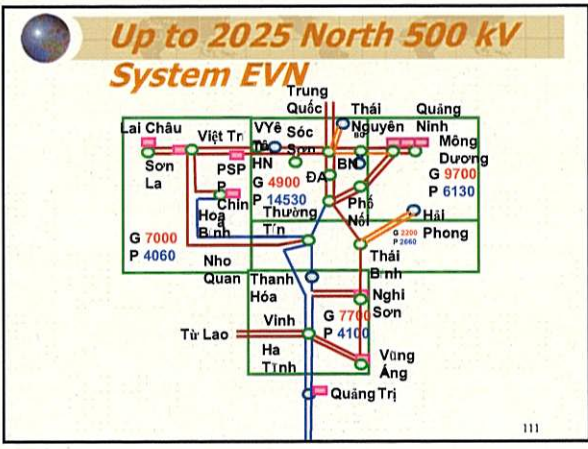
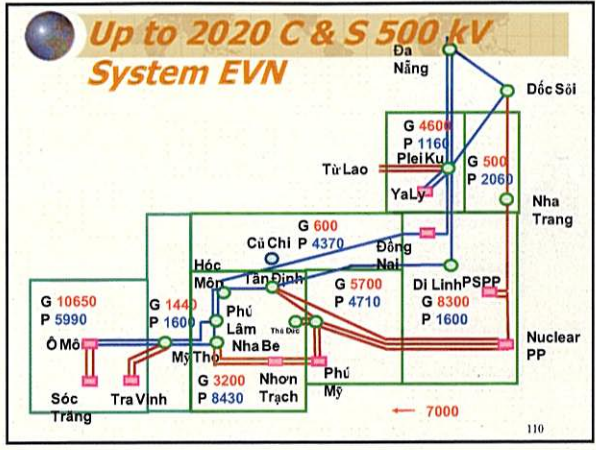
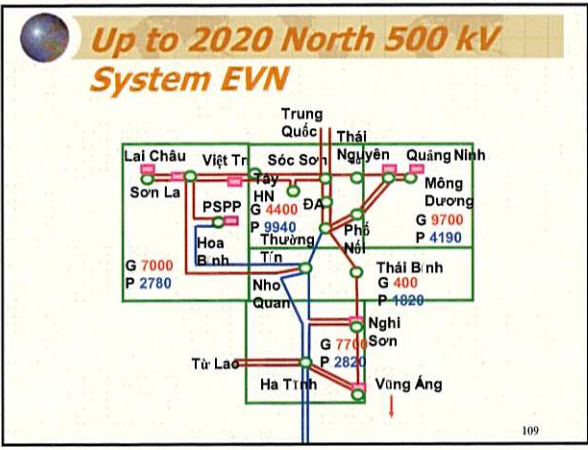

End of Session
Thank you for your attention!

113

The Study on National Power Development Plan for the period of 2006-2015, perspective up to 2025 in Vietnam

Economic/Financial analysis

(CONTENTS)

1. Approach
2. Basic parameters
3. Precondition of the calculation
4. Analysis result

December 2005

Approach

- The financial projections have been conducted following approach.
 - Period... from 2005 to 2025
 - Statements...
 - 1) Income Statement
 - 2) Balance Sheet
 - 3) Cash Flow Statement
 - Units... Following EVN group
 - 1) Independent accounting units
 - 2) Dependent accounting units
 - 3) Project management units

115

Basic Parameters

- Exchange rate
 - 1US\$ = 15,800 VND (fixed)

116

Basic Parameters

Investment items

```

    graph TD
      A((Annual investment cost)) -- "Investment activity (cash out)" --> B[Cash flow statement]
      A --> C[Work in progress (asset)]
      C --> D[Balance sheet]
      C -- "Operating" --> E[Working fixed assets (asset)]
      E --> F[Balance sheet]
      E -- "Decrease in value by the use" --> G[Depreciation cost]
      G --> H[Income statement]
  
```

117

Basic Parameters

- Depreciation rate
(Decrease rate in value by the use)

The kind of Property	rates
Hydro	6.5%
Thermal	8.5%
Gas turbine	9.0%
Nuclear power plan	5.0%
Transmission	8.5%
Distribution	10.0%
Current assets	10.0%

118

Basic Parameters

Borrowing items

```

    graph TD
      A((Annual Borrowing)) -- "Financing activity (cash in)" --> B[Cash flow statement]
      A --> C[Long term debt (liability)]
      C --> D[Balance sheet]
      C -- "Payment of Interest" --> E[Financing activity (cash out)]
      E --> F[Cash flow statement]
      E --> G[Interest cost]
      G --> H[Income statement]
  
```

119

Basic Parameters

Borrowing items

```

    graph TD
      A((Repayment of Borrowing)) -- "Financing activity (cash out)" --> B[Cash flow statement]
      A --> C["(decrease) Long term debt"]
      C --> D[Balance sheet]
  
```

120



Basic parameters

Borrowing conditions

Donor	Grace Period	Repaymnt Period	Interest Rate
From the Gov.	4year	8year	2.4%
WB	5year	20year	6.9%
JBIC (OECE)	5year	25Year	2.2%
ADB	5year	15year	7.0%
International loan	3year	13year	4.5%
Long term local loan	3year	13year	8.0%
Short term local loan	3year	13year	10.0%
Exinting loan	3year	10year	5.4.0%

121



Basic Parameters

Revenue items

- ◆ Sales of electricity ... Power demand × Selling price
- ◆ Other revenue ...
 - 1) Power construction
 - 2) Mechanical service
 - 3) Wiring and connection
 - 4) Investigation and design
 - 5) Electricity testing and repairing
 - 6) Telecommunication services
 - 7) Other
(increase every year 3%)

122



Basic parameters

Expense items

- ◆ Operational & maintenance cost
- ◆ Salaries
- ◆ Depreciation cost
- ◆ Electricity purchase cost
- ◆ Fuel cost
- ◆ Interest expenses
- ◆ Management cost
- ◆ Other

123



Basic parameters

Tax items

The kind of tax	rates
Natural resource tax	2.0%
VAT	10.0%
Import tax	7.0%
Income tax	28.0%

124



Precondition of the calculation

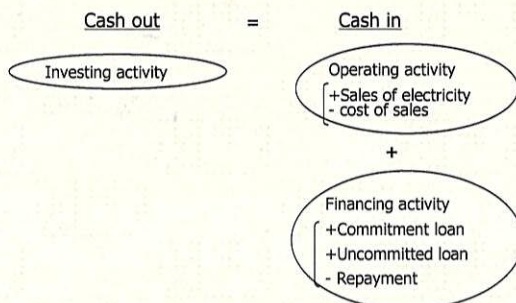

125



Analysis Results (Case 1)

Based on PDP 6

- Investment cost (2005-2025)
- Power demand (2005-2025)
- Sales price increase until 7 ¢
(without VAT 6.3 ¢)

126

Analysis Result

Income Statement

Unit: Billion VND

	2005	2010	2015	2020	2025
Revenue	35724	97278	165244	257703	381816
Expenses	(34633)	(96527)	(163325)	(256501)	(363691)
Net income before tax	1091	751	1919	1202	18125
Income tax	305	210	537	337	5075
Net income after tax	785	541	1382	866	13050

127

Analysis results

Balance sheet

Unit: Billion VND

	2005	2010	2015	2020	2025
Total Assets	123,196	298,003	432,248	552,329	496,276
Non-current assets	94,461	265,759	391,904	512,565	463,989
Current assets	28,735	32,243	40,345	39,765	32,287
Shares	41,099	39,080	47,489	32,546	46,894
Liabilities	82,096	258,922	384,759	519,783	449,382

128

Analysis Result

Cash Flow Statement

Unit: Billion VND

	2005	2010	2015	2020	2025
Operating activities	20,262	31,889	60,650	92,524	127,639
Investing activities	(29,041)	(51,007)	(64,243)	(91,940)	(36,375)
Financing activities	18,015	16,917	4,261	(774)	(99,832)
Net increase in cash	9,236	(2,200)	668	(190)	(8,568)
Bank balance and cash at beginning of the year	12,232	17,900	13,515	2,365	(10,202)
Bank balance and cash at end of the year	21,468	15,700	14,183	2,175	(18,770)

129

Analysis Result

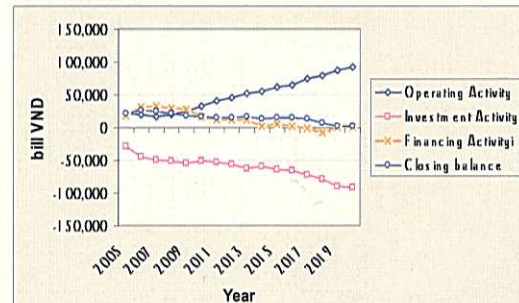

130

Analysis Result

Cash Flow Items

- Simulated the funding plan to avoid cash crises.

Result

- Closing balance will be able to maintain almost the same amount until 2020.
- On the other hand, heavy borrowings will be needed.

131

Analysis Result

Cash Flow Items

Unit: Billion VND

	2006	2007	2008	2009	2010
Commitment loan	14,079	16,919	17,019	19,763	14,744
Uncommitted loan	23,951	27,430	34,875	36,660	39,077
Total loan	38,030	44,350	51,894	56,423	53,821

Uncommitted loan means the amount of money shortage.

132

Analysis results (Case 2)

- Based on PDP 6
- The following supposition is added.
- Investment cost decrease two-third until 2011 of PDP6.

133

Analysis Result

Cash Flow Statement

Unit: Billion VND

	2005	2010	2015	2020	2025
Operating activities	16,503	27,486	51,083	84,573	122,974
Investing activities	(16,617)	(23,151)	(48,493)	(68,492)	(6,275)
Financing activities	5,975	(5,406)	(2,416)	(14,919)	(87,444)
Net increase in cash	5,862	(1,071)	174	1,162	29,255
Bank balance and cash at beginning of the year	12,232	9,366	10,039	(4,838)	(14,795)
Bank balance and cash at end of the year	18,094	8,295	10,213	(3,676)	14,460

134

Analysis Result

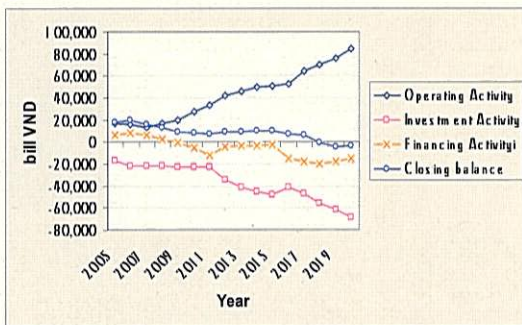

135

Analysis Result

Cash Flow Items

- Borrowings will decrease until 2011.

136

Analysis Result

Cash Flow Items

Unit: Billion VND

	2006	2007	2008	2009	2010
Commitment loan	14,124	15,935	15,269	16,716	12,181
Uncommitted loan	4,758	5,601	4,815	2,733	4,256
Total loan	2,822	3,318	4,327	3,675	7,520

Burden of uncommitted loan will decreased.

137

Recommendation

- New loans should be committed for avoiding the cash shortage (2005-2010) or
- Investment cost should be decreased (2005-2010)

Increase of power sales can investment cost after 2011.

138

End of Session

Thank you for your attention!

139

The Study on National Power Development Plan for the period of 2006-2015, perspective up to 2025 in Vietnam

Sector Reform and Electricity tariffs

December 2005

Japan International Cooperation Agency (JICA)

Tokyo Electric Power Co., Inc. (TEPCO)
Tokyo Electric Power Service Co., Ltd. (TEPCO)

Sector Reform Progress

Legal framework and reform

In November 2004, the Electricity law of Vietnam was passed by National Assembly and effective from the 1st July 2005. According to the Law, the Power market will be gradually established in Vietnam. The competitive power market will be developed through following four stages.

- ◆ **2005-2007 : Preparation stage for establishing power market**
- ◆ **2008-2013 : Competitive generation market**
- ◆ **2014-2018 : Competitive whole sale market**
- ◆ **After 2018 : Full competitive retail market**

141

Policy Targets and Priorities

- ◆ To reduce electricity price by introducing competition
gain of end user's profit → risk of volatility
- ◆ To vitalize the economy by introducing competition
abolition of government regulation → validity of unbundling
- ◆ Stable supply on supply side : "best fuel mix"
Making long - term demand forecasts
Implementing long - term investment in facilities
- ◆ Stable supply on demand side : "universal service"
Reasonable price Fairness between customers and regions

142

