

APPENDIX 3.2

DESCRIPTION OF SURVEY TASKS

APPENDIX 3.2 DESCRIPTION OF SURVEY TASKS

1. Preparatory Work

The candidate survey locations were visited several times to:

- Select a suitable location for each survey station.
- Determine the required manpower of surveyors and supervisors
- Sketch the site and its surrounding features.

The following precautions were considered when selecting the survey locations:

- The survey site has to be on a straight part of the road to provide sufficient sight distance for the surveyor to see the coming vehicles and to secure the safety of the survey team.
- The survey site should be on a level road section to avoid the increase in vehicle speed in the down-grade direction which may increase the hazards possibility against the survey team.
- The survey site has to be on an illuminated section as possible to provide adequate vision to the survey team during dark periods of the survey works and maintain safety aspects to the survey team.
- The survey site has to be easily accessible by optimizing the transport process of the survey team to/from each site.
- A detailed sketch for each survey station site should be prepared by the site supervisors.

(1) Locations of Traffic Count Survey

A total of 17 traffic count stations were, originally, selected to carry out the manual classified count (MCC) for two days during 18 hours starting from 6:00 A.M. till 12:00 A.M. These count stations can be classified into two major categories. The first category (10 bridges) is represented by a screenline along the Nile River. The traffic of the second category represented by the remaining 7 count stations enter/exit the study area within the Ring Road

Based on the discussion with the Steering Committee, it was concluded to modify the survey program by conducting the traffic count survey for only one day, while increasing the total number of count stations and maintaining the same cost of traffic

count survey. Additional 11 count stations were added to the planned 17 locations, which yields a total of 28 count stations. The addition of new count stations were selected to be on the route of the proposed expressway network. Moreover, the survey period was reduced to 16 hours instead of 18 hours for security and safety considerations.

Figure A3.2-1 illustrates the location map of the following three categories:

- Ten (10) bridges across the Nile River, connecting Cairo Governorate with Giza Governorate, which are compatible with the locations counted during the screenline survey of CREATS Phase 1.
- Seven (7) count stations crossing the Ring Road, which are selected from the traffic count stations of major arterials of CREATS Phase 1.
- Eleven (11) new count stations located on the route of the proposed expressway network.

The count stations are denoted with different symbols; ellipse, triangle and star for Nile bridges, major arterials and new (additional) count stations, respectively.

Table A3.2-1 presents the category, number, code, site name and description of each count station. It is the intention to present the results of traffic count survey and its related issues based on the aforementioned three categories; Bridges (B), Arterials (A) and New sites (NW).

Appendix 3.3 illustrates the photos, satellite images, schematic sketches and cross-sections for different count stations by direction.

(2) Locations of Willingness-to-Pay Survey

Locations of the willingness-to-pay survey were selected to be in convenient places to avoid any interruption of the traffic flow on the main corridors in Greater Cairo Region. Therefore, the road users were interviewed at thirteen (13) different locations including five gas stations, one shopping mall, two parking garages, four shared taxi terminals and some terminals of light truck (pickup). Moreover, the decision makers in nine (9) different companies working in the fields of passenger public transport, tourist service and freight transport were interviewed. Table A3.2-2 gives a description of different willingness-to-pay survey locations for road users, while Table A3.2-3 shows the list of different types of interviewed companies

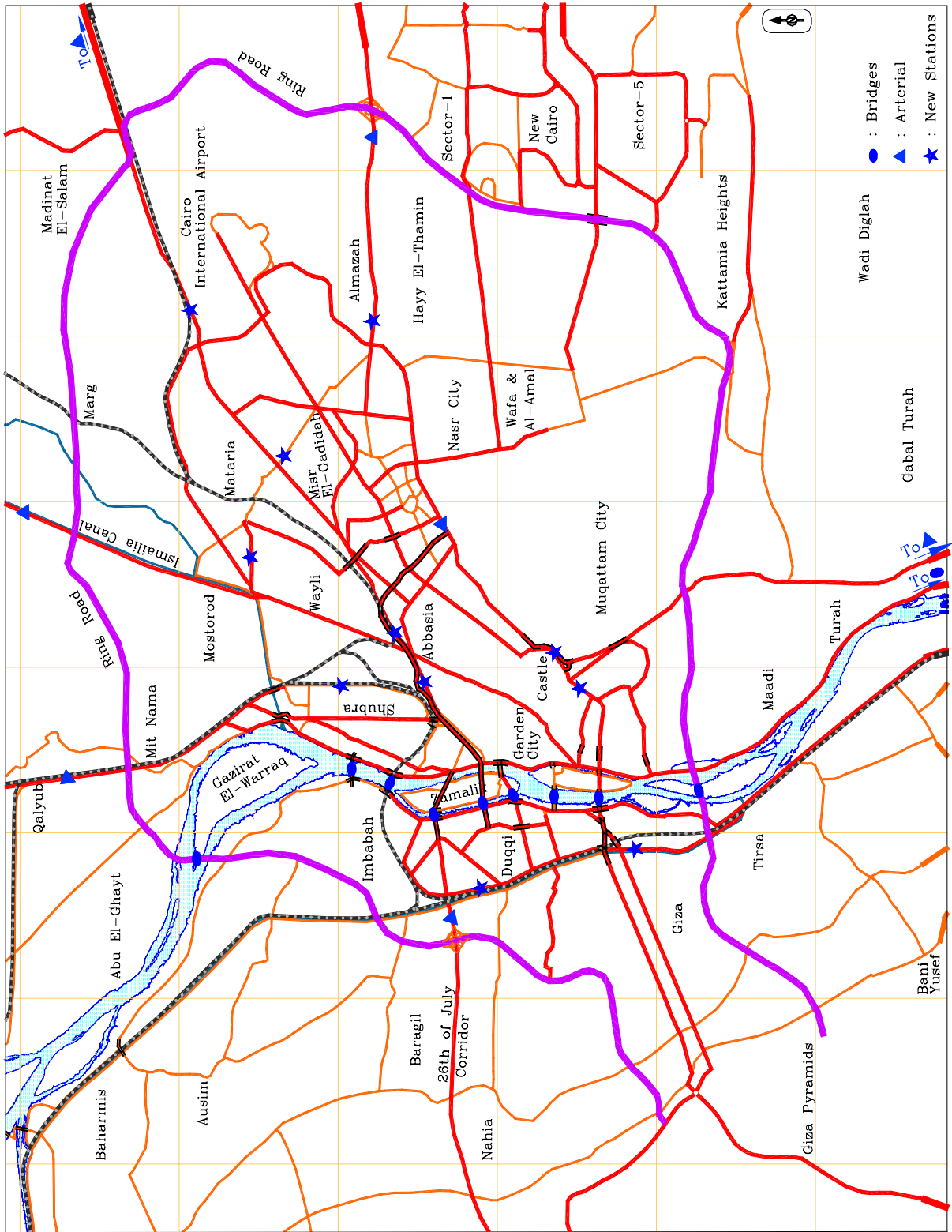

Figure A3.2-1 Location Map of Traffic

Table A3.2-1 Description of Traffic Count Locations

Type	No.	Code	Site Name	Description of Count Location
BRIDGES	1	B01	Warraq Bridge	Middle of the Bridge (over the Nile River)
	2	B02	Rodh El Farag Bridge	Middle of the Bridge
	3	B03	Imbaba Bridge	Middle of the Bridge
	4	B04	15 th of May Bridge	Middle of the Bridge (Zamalek – Kit Kat)
	5	B05	6 th of October Bridge	Middle of the Bridge (Zamalek - Agoosa)
	6	B06	Galaa Bridge	Middle of the Bridge
	7	B07	Gamah Bridge	Middle of the Bridge
	8	B08	Giza Bridge	Middle of the Bridge
	9	B09	Moneeb Bridge	Middle of the Bridge (before Moneeb Exit)
	10	B10	Marazeeq Bridge	Middle of the Bridge
ARTERIALS	11	A18	26th of July Corridor	Between Railway Line and Ring Road
	12	A21	Suez Desert Road	Between Km 4.5 and the Ring Road
	13	A35	Alex. Agriculture Road	Qalyobeya – Ring Road
	14	A36	Ismailia Agriculture Road	2 to 3 km North to Ring Road
	15	A39	Ismailia Desert Road	Between Ring Road and NH No. 45
	16	A42	Autostrade	3 to 5 Km South of NH No. 23
	17	AC20	Nasr Road	Between Ramsis St. and Fangary St. (ENIT)
EXPRESSWAY ROUTES	18	NW01	Gesr El-Suez St.	Between Ring Road and Ain Shams St.
	19	NW02	Suez Desert Road	Near the intersection with Autostrade
	20	NW03	Abo Bakr El-Sedeeq St.	Between Tagneed Square and Orooba Road
	21	NW04	Kablat Street	Between Ismailia Canal and Mataria Square
	22	NW05	Lotfy El-Sayed	Near Abbassia Square
	23	NW06	Autostrade Road	Between Mansheyet Naser and Citadel
	24	NW07	Ahmed Helmy St.	Between Ramsis Square and Abood Tunnel
	25	NW08	Ramsis St.	Between Ramsis Square and Ghamra
	26	NW09	Salah Salem Road	Before Magra El-Oyoon Street
	27	NW10	Tereat El-Zomor Road	South of Haram St.
	28	NW11	Sudan St.	Between 26 July Corridor and Gameat El-Dowal El-Arabia St.

Table A3.2-2 Description of Willingness-to-Pay Survey Locations for Road Users

Type	No.	Site	Site Description
Gas Station	1	Abbas El-Aqqad Gas Station	Intersection of Abbas El-Aqqad & Autostrade
	2	Autostrad Gas Station (Esso)	In front of Arab Contractors Sporting Club
	3	Ismailia Desert Road Gas Station	After Airport Bridge on Ismailia Desert Road
	4	Dokky Gas Station	Near Dokky square
	5	Bahr El-Aazam Gas Station	Before the intersection with Ring Road
Mall	6	In front of City Mall	Makram Ebeid Street
Garages	7	Opera Garage	Opera Square
	8	Bostan Garage	Tahrir Street
Terminal	9	Ramsis Microbus Terminal	Ramsis Square
	10	Abdel-Moniem Reyad Microbus Terminal	Abdel-Moniem Riyad Square
	11	Giza Microbus Terminal	Giza Square
	12	In front of Cairo Railway Station	Ramsis Square
	13	Different Light Truck (pickup) Terminals	Nasr City Area

Table A3.2-3 Description of Willingness-to-Pay Survey Locations for Transport Companies

Type	No.	Company Name	Type of Transport Service
Passenger	1	Lebanon for Passenger Transportation	Public Passenger Transportation Company
	2	Transportation Facilities Industry for Passenger Transportation	Public Passenger Transportation Company
	3	SOOT Company for Passenger Transportation	Public Passenger Transportation Company
Tourist	4	EASTMAR Tourist	Tourist Transportation Company
	5	National Travel Service	Tourist Transportation Company
Freight	6	Nile for Direct Transport	Freight Transportation Company
	7	Nile for Freight Transportation	Freight Transportation Company
	8	Alexandria for Furniture Transportation	Freight Transportation Company
	9	El-Mustafa for Furniture Transportation	Freight Transportation Company

(3) Preparation of the Survey Program and Mobilization Plan

The survey time schedule of the traffic survey tasks, outlined in section 3.2, is shown in Table A3.2-4.

Table A3.2-4 Time Schedule of Traffic Survey

Tasks	Time Span (Weeks)					
	1 7/5/05	2 14/5/05	3 21/5/05	4 28/5/05	5 4/6/05	6 11/6/05
Preparation of work plan	————					
Recruiting of surveyors and supervisors	————					
Training of surveyors and supervisor		————				
Arrangement of work plan with police, traffic departments and other relevant authorities	————	————				
Conducting of field survey			————	————		
Computer data entry				————	————	
Checking of data quality					————	
Data processing, tabulation and preliminary analysis					————	————
Preparation of survey report					————	————

(4) Preparation of the Survey Forms

Different survey forms were designed to accommodate different types of field survey.

1) Survey Form of Manual Classified Count

As for the survey form of traffic count, twelve (12) vehicle types were chosen to be counted manually to be in accordance with the same vehicle types counted in CREATS Phase 1 in 2001. This will facilitate the comparison between the traffic volumes of the current survey in 2005 with survey results of 2001. The twelve vehicle types are listed below:

- Passenger Car
- Taxi (metered taxi and intercity taxi).

- Microbuses (shared taxi)
- Public Transport minibus
- Public Transport bus
- Private Bus (school bus, company bus, tourist bus, etc.)
- Light commodity vehicle (pickup and vans)
- 2-Axles truck
- 3-Axles truck
- Heavy truck (more than 3-axle, trailer, semi-trailer).
- 2-wheeler (bicycle and motorcycle)
- Others (military, police, ambulance, etc.)

The English version of manual classified traffic count survey form is shown in Appendix 3.3-1.

2) Willingness-to-Pay Survey Forms

The interview survey form (1) of road-user, which is shown in Appendix 3.3-2, was designed to include general information, personal data and trip data as outlined below:

- General information such as location code, sample ID, date, time and type of the interviewed vehicle.
- Personal information such as gender, age, occupation, car availability, monthly income and the amount of monthly electricity bill.
- Trip information such as trip origin, trip destination, travel time, trip frequency, trip purpose and the toll monetary value the interviewee is willing to pay for a reduction of 25% and 50% of his/her travel time.

The interview survey form (2) of road-user, which is shown in Appendix 3.3-3, included stated preference questionnaire regarding his/her willingness-to-pay different toll values in accordance with different levels of travel time savings in case of work trips.

Regarding the interview with the companies, the following information was collected using the interview survey form shown in Appendix 3.3-4:

- Company type
- Total number of staff and workers
- Fleet size
- Total transport volume
- Vehicle routes and their relevant data
- Toll value the company is willing to pay for 25% and 50% of travel time savings.

(5) Coordination of Traffic Survey

To achieve a successful and smooth operation of traffic survey, a full coordination had to be made with several authorities and organizations such as:

- Ministry of Interior.
- Ministry of Transport.
- National Institute of Transport (ENIT).
- General Department for Traffic Police.
- Local Traffic Police Departments of Cairo and Giza.
- Managers of garages, gas stations and terminals of shared taxi and light trucks.

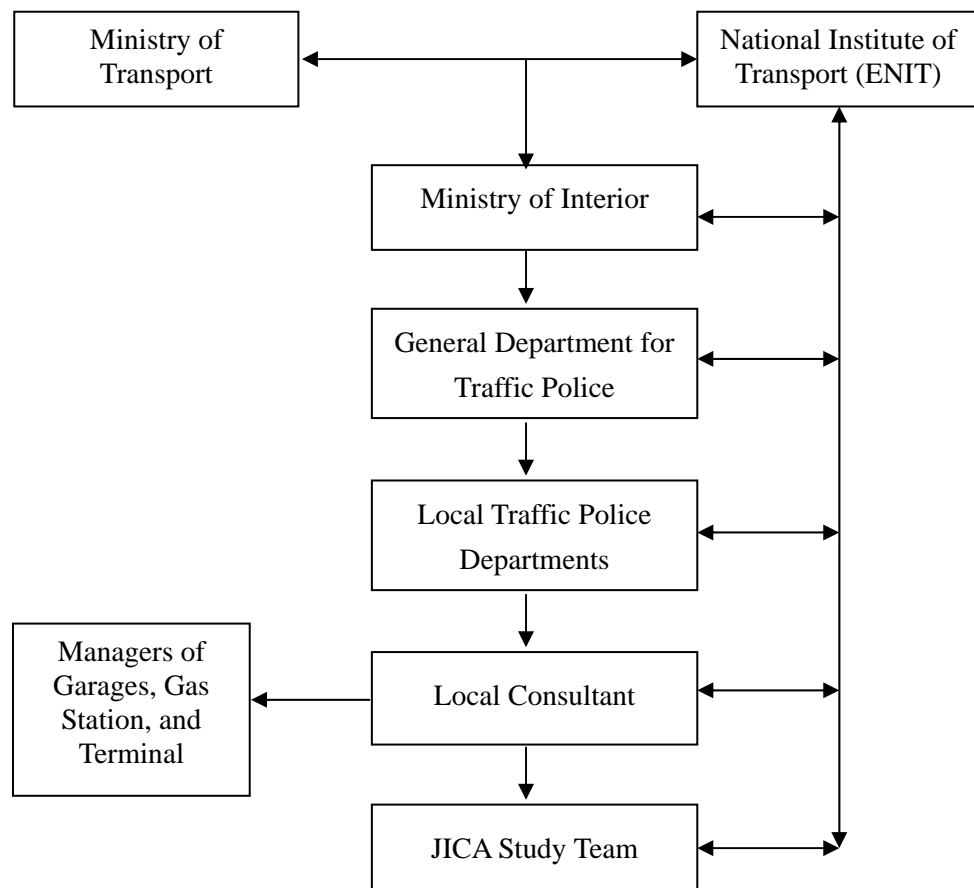

Figure A3.2-2 Coordination Relationship between Different Authorities

2. Execution of Field Survey

(1) Manual Classified Traffic Count Survey

The classified traffic count was carried out for all vehicles for both traffic directions for 16 hours from 6.00 AM to 10:00 PM during typical weekdays (Monday through Wednesday). The survey was performed manually using the statistical tally system for 15-minute count interval. The count program started on Monday 23/5/ 2005 and ended on Monday 30/5/2005. The traffic count survey for all bridges was performed in the same day to maintain the consistency among the collected data. Table A3.2-5 presents the survey schedule of the classified traffic count survey for different sites by traffic direction. Figure A3.2-3 depicts the code of different traffic count stations and the definition of the first direction of travel. The Study Team sets a rule for defining the direction of travel to be unified as much as possible. Direction 1 is defined by the movement toward the North or East, except for only one count station (NW05: Lotfy El-Sayed St.), which is a one-way street toward the West direction. This implies that Direction 2 is the opposite of that shown on Figure A3.2-3.

The number of surveyors for each location was determined based on traffic volume and site investigation for each count station. In case of heavy traffic, three surveyors were assigned to count each direction; private cars by one surveyor, taxi and shared taxi vehicles by a second surveyor and other vehicle types by the third surveyor.

It should be noted that traffic count survey was carried with full coordination and permission of the General Traffic Administration and the Traffic Department of each Governorate. One police officer was assigned to secure two or three count stations.

Quality check of traffic count data was performed through counting the same vehicle type at the same period by a supervisor and the standby surveyor(s) in separate sheets. This operation was repeated periodically during the survey period. Based on this quality check process, there were three count results for some period, which could be used as check values.

(2) Willingness-to-Pay Survey

Initially, a sample size of 1500 road users were planned to be interviewed, who are using different modes of transport. The Roadside Interview sample was proportionally divided among different vehicle types based on the modal share within the traffic stream. Five vehicle types were selected including private car, taxi, shared taxi, light truck, bus, and heavy truck. However, it was decided to exclude the bus and heavy truck from Road Side Interview because neither the driver nor the passenger (in case of bus) is a decision maker who can decide the willingness to pay a toll for a certain amount of time saving. Therefore, the Study Team decided to conduct this kind of

survey by interviewing the decision makers (Owner or General Manager) of 3 bus companies, 2 tourist companies and 4 freight companies.

Table A3.2-6 shows the planned and achieved sample size for each vehicle type. The last row in the Table A3.2-6 indicates that an overall achievement factor (achieved sample divided by planned sample) is 1.66 was obtained for road side interview survey.

Table A3.2-5 Schedule of Traffic Survey for Different Sites by Direction

Site	No.	Code	Site Name	Dir 1: To	Dir 2: To	Survey Date
BRIDGES	1	B01	Warraq Bridge	Qalyobeya	Giza	23/5/2005
	2	B02	Rodh El-Farag Bridge	Cairo	Giza	23/5/2005
	3	B03	Imbaba Bridge	Cairo	Giza	23/5/2005
	4	B04	15 th of May Bridge	Cairo	Giza	23/5/2005
	5	B05	6 th of October Bridge	Cairo	Giza	23/5/2005
	6	B06	Galaa Bridge	Cairo	Giza	23/5/2005
	7	B07	Gamah Bridge	Cairo	Giza	23/5/2005
	8	B08	Giza Bridge	Cairo	Giza	23/5/2005
	9	B09	Moneeb Bridge	Cairo	Giza	23/5/2005
	10	B10	Marazeeq Bridge	Cairo	Giza	23/5/2005
ARTERIALS	11	A18	26th of July Corridor	Lebanon Sq.	6th of October City	24/5/2005
	12	A21	Suez Desert Road	Suez	Cairo	24/5/2005
	13	A35	Alex. Agriculture Road	Alexadria	Cairo	24/5/2005
	14	A36	Ismailia Agriculture Road	Ismailia	Cairo	25/5/2005
	15	A39	Ismailia Desert Road	Ismailia	Cairo	25/5/2005
	16	A42	Autostrade	Cairo Airport	Helwan	30/5/2005
	17	AC20	Nasr Road	Cairo Airport	Helwan	30/5/2005
EXPRESSWAY ROUTES	18	NW01	Gesr El-Suez St.	Ismailia	CBD	24/5/2005
	19	NW02	Suez Desert Road	Suez	Cairo	25/5/2005
	20	NW03	Abo Bakr El-Sedeeq St.	Orooba St.	Tagneed Sq.	24/5/2005
	21	NW04	Kablat St.	Mataria Sq.	Ismailia Canal	30/5/2005
	22	NW05	Lofy El-Sayed St.	Ramsis Sq.	**	30/5/2005
	23	NW06	Autostrade	Cairo Airport	Helwan	24/5/2005
	24	NW07	Ahmed Helmy St.	Qalyob	CBD	30/5/2005
	25	NW08	Ramsis St.	Abbassia Sq.	Ramsis Sq.	30/5/2005
	26	NW09	Salah Salem Road	Cairo Airport	Giza Sq.	24/5/2005
	27	NW10	Tereat El-Zomor Road	Haram St.	Ring Road	24/5/2005
	28	NW11	Sudan St.	Imbaba	Haram St.	24/5/2005

** Note: One-way Street

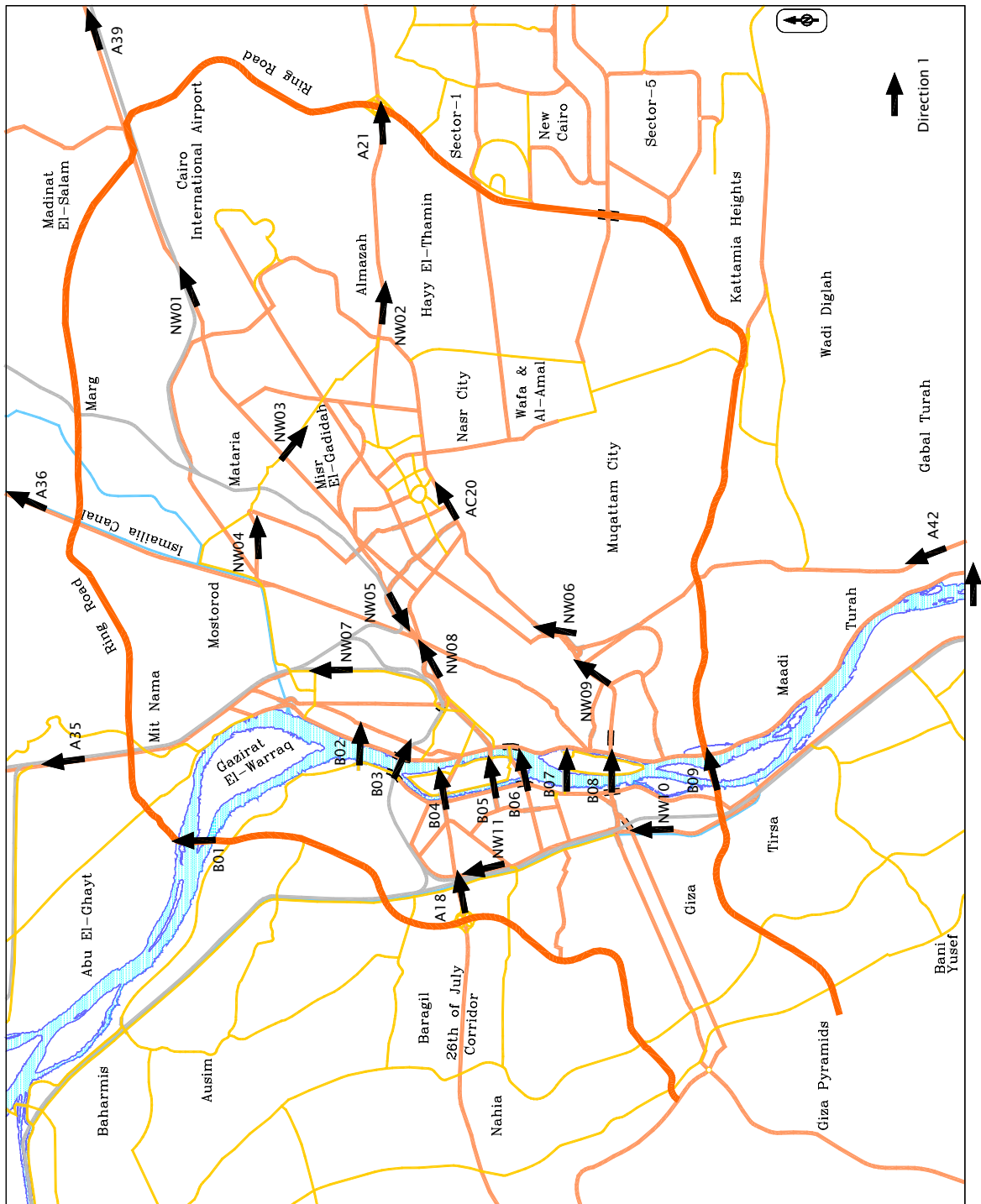

Figure A3.2-3 Definition of Code and Direction of Travel for Different Count

Table A3.2-6 Planned and Achieved Interview Sample Size for Different Vehicle Types

Vehicle Type	Private Car	Taxi	Shared Taxi	Light Truck	Bus	Heavy Truck	Total
Planned	704	243	146	140	NA*	NA*	1233
Achieved	1122	408	241	278	Five Bus Companies	Four Truck Companies	2049
Factor	1.59	1.68	1.65	1.99	NA*	NA*	1.66

* NA: Not Applicable

The willingness to pay survey was carried out in two weeks started on Sunday 22/5/2005. Roadside Interview survey ended on Wednesday 25/5/ 2005, while the interview with transport companies of buses and heavy truck was extended for another week. Tables A3.2-7 and A3.2-8 show the schedule of interview survey for the selected sites.

Table A3.2-7 Schedule of Willingness-to-Pay Survey for Road Users

Type	No.	Site	Sunday 22/5/05	Monday 23/5/05	Tuesday 24/5/05	Wednesday 25/5/05
Gas Station	1	Abbas El-Aqqad Gas Station	√	√		
	2	Autostrad Gas Station (Esso)	√		√	
	3	Ismaillia Desert Road Gas Station			√	√
	4	Dokky Gas Station	√	√		
	5	Bahr El-Aazam Gas Station		√		√
Mall	6	In front of City Mall				
Garages	7	Opera Garage		√	√	
	8	Bostan Garage		√	√	
Terminal	9	Ramsis Microbus Terminal	√			√
	10	Abdel-Moniem Reyad Microbus Terminal			√	√
	11	Giza Microbus Terminal		√	√	
	12	In front of Cairo Railway Station	√			√
	13	Different Light Truck (pickup) Terminals	√			√

Table A3.2-8 Schedule of Willingness-to-Pay Survey for Transport Companies

Type	No.	Company Name	Starting Date	Ending Date
Passenger	1	Lebanon for Passenger Transport	22/5/2005	31/5/2005
	2	Transport Facilities Industry for Passenger Transport	23/5/2005	5/6/2005
	3	SOOT Company for Passenger Transport	22/5/2005	2/6/2005
Tourist	4	EASTMAR Tourist	24/5/ 2005	4/6/2005
	5	National Travel Service	22/5/2005	4/6/2005
Freight	6	Nile for Direct Transport	23/5/2005	6/6/2005
	7	Nile for Freight Transport	23/5/2005	6/6/2005
	8	Alexandria for Furniture Transport	22/5/2005	1/6/2005
	9	El-Mustafa for Furniture Transport	24/5/ 2005	6/6/2005

3. Data Processing

Data processing procedure for traffic count and willingness to pay surveys can be summarized as follows:

- The field survey forms were prepared with the pre-specified numbers and delivered to the survey coordinator, who delivered them to the field supervisors. Each set of forms had a cover page which indicates the survey code, site code and name, number of sheets and survey date and time. The number of the interview sheets for transport companies was nine sheets divided into five sheets for public passenger and tourist transport companies and four sheets for freight transport companies.
- The field survey forms were distributed to the surveyors, who filled them and returned them back to the field supervisors. The supervisors reviewed the field survey forms to check their numbers and to make sure that they were completely filled without any missing data.
- The survey coordinator received the forms from the field surveyors and reviewed them again. In case of any missing data, they were checked by the field survey group to complete these data under the supervision of the leader of this group.

- The data processing coordinators received the field data forms from the survey coordinator and reviewed their completeness. In case of any missing data, they were checked by the survey coordinator and the field surveyors to complete these data, under the supervision of the survey group leader.
- For traffic count survey, the data processing staff counts the tally marks for manual counts and calculates the net count for each vehicle type of each counting interval. The net counts were entered into the field survey forms and reviewed.
- Data entry forms were prepared on computers and were checked with the field survey forms to ensure their complete coincidence.
- Pre-data-entry checks were conducted by the leader of survey group and the leader of data processing.
- The data were entered into the computer and reviewed. A draft was printed and reviewed with the field survey forms to correct any errors.
- Errors checks were conducted by the data processing staff. A random sample of the field survey forms was reviewed with the computer files. Moreover, all computer files were examined for possible source of error, indicated by any outliers' readings.
- The field survey forms were archived in a closed cabinet
- Data validation was conducted by the leader of survey group and the leader of data processing group to find out any invalid data and correct it.
- Preliminary analysis was carried out and a final print out of both the survey data and the results of the preliminary analysis were printed.
- All computer files of survey data were copied on another partition of the hard desk and on CD's.

The following two sections present the outcomes of traffic count and willingness to pay surveys, respectively.

APPENDIX 3.3

TRAFFIC SURVEY FORMS









Ain Shams University
 Faculty of Engineering
 Engineering
 Consultancy Center

Classified Traffic Volume Count
 Form
 15 Minutes interval

Ministry of Transport
 Egyptian National Institute of
 Transport (ENIT)
 Japan International Cooperation
 Agency (JICA)

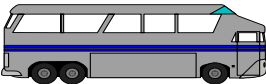
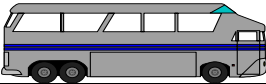
Location:
 Site Code:
 Direction:
 Date:

Surveyor:
 Supervisor:
 Starting Time:
 Form Number:

Vehicle Class	Number of Vehicles
Passenger Car 	
Taxi 	
Shared Taxi 	
Public Minibuses 	
Public Buses 	
Private Buses 	
Pick-up and Vans 	
2-Axles Truck 	
3-Axles Truck 	
>3-Axle Truck 	
2-wheeler (motorcycle)	
Others (military, police, ambulance and etc.)	

Appendix 3.3-1 Survey Form of Manual Classified Traffic Count

Ain Shams University
Faculty of Engineering

Engineering Consultancy Center

Ministry of Transport

Egyptian National Institute of Transport (ENIT)

Japan International Cooperation Agency (JICA)

CREATES SURVEY ON WILLINGNESS-TO-PAY ATTITUDE OF VEHICLE USERS

General Info.	Sample ID	<input type="text"/>	Date (month/day)	<input type="text"/>		
	Location	<input type="text"/>	Time	<input type="text"/>		
	1- Vehicle Type	<input type="checkbox"/> 1- Passenger car	<input type="checkbox"/> 2- Taxi	<input type="checkbox"/> 4- Shared Taxi (Microbus)	<input type="checkbox"/> 4- Bus	<input type="checkbox"/> 5- Truck

Personal Information	2- Gender	<input type="checkbox"/> 1-Male	<input type="checkbox"/> 2-Female	3- Age	<input type="checkbox"/> 1)20-29	<input type="checkbox"/> 2)30-39	<input type="checkbox"/> 3)40-49	<input type="checkbox"/> 4)50-59	<input type="checkbox"/> 5)>60	
	4- Car availability	<input type="checkbox"/> 1-Always	<input type="checkbox"/> 2-Often	5- Occupation	<input type="checkbox"/> 1- Admin.	<input type="checkbox"/> 2- Professional	<input type="checkbox"/> 3- Tech./assist.	<input type="checkbox"/> 4- Clerk	<input type="checkbox"/> 5- Sale/Services	<input type="checkbox"/> 6- Farmer/fisher
		<input type="checkbox"/> 3-Occasionally	<input type="checkbox"/> 4-Seldom	<input type="checkbox"/> 5-Not available	<input type="checkbox"/> 7- Craftman	<input type="checkbox"/> 8- Production	<input type="checkbox"/> 9- Unskilled	<input type="checkbox"/> 10- Student	<input type="checkbox"/> 11- House wife	<input type="checkbox"/> 12- Retired
	6- Monthly Income (L.E.)	<input type="text"/>	7- Electricity Bill	<input type="text"/> L.E.						
		<input type="checkbox"/> 1) <300	<input type="checkbox"/> 2) 301-500	<input type="checkbox"/> 3) 501-1000	<input type="checkbox"/> 4) 1001-2000	<input type="checkbox"/> 5) 2001-5000	<input type="checkbox"/> 6) >5000	<input type="checkbox"/> 7) No income	<input type="checkbox"/> 8) Refuse	

Trip Information	8- Trip O-D	Where did you start this trip?	<input type="text"/>	<input type="text"/>								
		Landmark	<input type="text"/>	<input type="text"/>								
		Where do you go this trip?	<input type="text"/>	<input type="text"/>								
		Landmark	<input type="text"/>	<input type="text"/>								
	9- Travel Time	How long does it take?	<input type="text"/>	Minutes								
	10- Frequency	How often do you use a car for this trip purpose and OD per week?	<input type="text"/>	<input type="text"/>								
	11- Trip purpose	<input type="checkbox"/> 1. Work	<input type="checkbox"/> 7. Sending/ Fetching	<input type="checkbox"/> 2. Education	<input type="checkbox"/> 8. Recreation	<input type="checkbox"/> 3. Selling/Delivering	<input type="checkbox"/> 9. Medical treatment	<input type="checkbox"/> 4. Meeting/business	<input type="checkbox"/> 10. Social	<input type="checkbox"/> 5. Return to work place	<input type="checkbox"/> 11. Other	<input type="checkbox"/> 6. Shopping/Eating
	12- How much would you pay for travel time reduction of this trip by Urban Expressway ?	<input type="checkbox"/> 1) By 25% of travel time of this trip	<input type="checkbox"/> 2) By 50% of travel time of this trip	<input type="checkbox"/> 3) Nothing	<input type="text"/>	<input type="text"/>	<input type="text"/>	<input type="text"/>	<input type="text"/>			

Appendix 3.3-2 Willingness-to-Pay Survey Form (1) for Road User

Willingness-To-Pay For Travel Time Reduction

14-Given the conditions stated in the cases below for Ordinary Road and Toll Expressway, which would prefer to use for "to work" trip purpose - one way direction (Please indicate choice Case A, B and C)

	Road Type	Travel Time (min)	Travel Cost (LE)	Choice (pls. Check)	
A	Ordinary Road	90	0	<input type="checkbox"/>	1
	Toll Expressway	50	20	<input type="checkbox"/>	
B	Ordinary Road	60	0	<input type="checkbox"/>	
	Toll Expressway	30	15	<input type="checkbox"/>	
C	Ordinary Road	30	0	<input type="checkbox"/>	
	Toll Expressway	10	8	<input type="checkbox"/>	
A	Ordinary Road	90	0	<input type="checkbox"/>	2
	Toll Expressway	50	15	<input type="checkbox"/>	
B	Ordinary Road	60	0	<input type="checkbox"/>	
	Toll Expressway	30	10	<input type="checkbox"/>	
C	Ordinary Road	30	0	<input type="checkbox"/>	
	Toll Expressway	10	8	<input type="checkbox"/>	
A	Ordinary Road	90	0	<input type="checkbox"/>	3
	Toll Expressway	50	10	<input type="checkbox"/>	
B	Ordinary Road	60	0	<input type="checkbox"/>	
	Toll Expressway	30	8	<input type="checkbox"/>	
C	Ordinary Road	30	0	<input type="checkbox"/>	
	Toll Expressway	10	5	<input type="checkbox"/>	
A	Ordinary Road	90	0	<input type="checkbox"/>	4
	Toll Expressway	50	8	<input type="checkbox"/>	
B	Ordinary Road	60	0	<input type="checkbox"/>	
	Toll Expressway	30	5	<input type="checkbox"/>	
C	Ordinary Road	30	0	<input type="checkbox"/>	
	Toll Expressway	10	3	<input type="checkbox"/>	
A	Ordinary Road	90	0	<input type="checkbox"/>	5
	Toll Expressway	50	5	<input type="checkbox"/>	
B	Ordinary Road	60	0	<input type="checkbox"/>	
	Toll Expressway	30	2	<input type="checkbox"/>	
C	Ordinary Road	30	0	<input type="checkbox"/>	
	Toll Expressway	10	2	<input type="checkbox"/>	

That's All. Thank You Very Much for Your Cooperation.

Appendix 3.3-3 Willingness-to-Pay Survey Form (2) for Road User

CREATES SURVEY ON WILLINGNESS-TO-PAY ATTITUDE OF VEHICLE USERS (COMPANIES)

General Info.

Sample ID

Date (month/day)

Company Name:

Company Info.

1- Company Type 1-Passenger Transport 2-Tourists Transport 3-Freight Transport

2- Total Number of Company Staff and Workers

3- No. of Fleet Vehicles

4- Total Transport Volume
 Passenger/day Ton/year

5- Vehicles Routes and Properties

Route		No. of Vehicles	Vehicle* Type	Daily Trips (2 directions)	Trip Time per Direction (min)	Tariff or ton Trans. cost	Actual Cost per ton or person
From	To						

6- How much would you pay for travel time reduction of this trip by Urban Expressway ?

- 1) By 25% of travel time of this trip L.E.
- 2) By 50% of travel time of this trip L.E.
- 3) Nothing

* In case of trucks mention the load and no. of axles, and in case of bus, minibus, or microbus mention the no. of seats and vehicle type

Appendix 3.3-4 Willingness-to-Pay Survey Form for Passenger/Freight Transport Companies

APPENDIX 3.4

TRAFFIC FLOW DATA

Appendix 3.4-1: Manual Classified Traffic Count Data at Warraq Bridge

Site : Warraq Bridge							Code: B01								
Dir 1: Qalyobeya							Date: 23/5/2005								
Start Hour	Number of Vehicles												Total		
	Car		Taxi		Bus				Truck					Motorcycle	
					Shared Taxi	Mini	Public	Private	Pickup	2-Axle	3-Axle	> 3 Axle			
06:00	136	23	124	0	3	101	252	91	2	97	4	0	833		
7:00	432	42	221	0	6	80	246	265	6	94	17	2	1,411		
8:00	448	44	244	0	2	35	286	296	5	82	19	0	1,461		
9:00	355	32	154	0	2	9	176	173	4	59	9	3	976		
10:00	318	43	186	0	1	5	283	297	11	77	11	3	1,235		
11:00	408	90	228	6	8	25	297	265	17	103	6	3	1,456		
12:00	324	62	128	1	2	31	343	252	35	109	20	16	1,323		
13:00	351	46	145	0	2	5	316	310	44	89	11	7	1,326		
14:00	440	108	171	0	6	8	328	336	20	98	11	17	1,543		
15:00	478	148	241	1	18	18	362	353	4	176	10	16	1,825		
16:00	565	65	413	0	14	38	425	403	8	155	18	13	2,117		
17:00	646	61	345	0	5	56	302	389	16	196	21	23	2,060		
18:00	598	78	316	0	3	57	306	460	17	336	8	13	2,192		
19:00	450	60	232	0	1	47	294	299	1	167	19	9	1,579		
20:00	499	82	269	0	3	35	285	264	8	118	12	3	1,578		
21:00	483	70	215	0	0	37	550	398	2	137	10	3	1,905		
Total	6,931	1,054	3,632	8	76	587	5,051	4,851	200	2,093	206	131	24,820		
%	27.9	4.2	14.6	0.0	0.3	2.4	20.4	19.5	0.8	8.4	0.8	0.5	100		

Site : Warraq Bridge							Code: B01								
Dir 2: Giza							Date: 23/5/2005								
Start Hour	Number of Vehicles												Total		
	Car		Taxi		Bus				Truck					Motorcycle	
					Shared Taxi	Mini	Public	Private	Pickup	2-Axle	3-Axle	> 3 Axle			
06:00	156	24	248	9	1	76	168	326	2	90	6	4	1,110		
7:00	584	36	562	1	0	165	477	88	6	67	26	13	2,025		
8:00	635	56	467	0	0	103	631	97	5	64	36	31	2,125		
9:00	408	20	120	0	1	54	537	77	1	65	21	18	1,322		
10:00	265	24	131	1	1	31	509	140	2	93	18	9	1,224		
11:00	306	26	108	0	0	12	430	228	8	54	14	10	1,196		
12:00	345	19	61	30	0	17	287	315	1	50	11	10	1,146		
13:00	288	37	54	0	1	28	329	394	14	82	14	3	1,244		
14:00	308	37	38	0	1	21	303	224	3	67	8	8	1,018		
15:00	523	73	147	27	5	24	144	225	19	125	1	0	1,313		
16:00	563	65	190	8	2	43	182	236	0	127	3	0	1,419		
17:00	607	46	147	1	1	68	162	222	21	129	3	0	1,407		
18:00	531	127	246	0	9	29	155	196	0	90	1	2	1,386		
19:00	327	85	191	3	1	39	185	205	84	164	9	0	1,293		
20:00	279	81	104	0	0	26	217	232	2	119	1	0	1,061		
21:00	186	74	102	0	1	33	185	185	1	109	5	2	883		
Total	6,311	830	2,916	80	24	769	4,901	3,390	169	1,495	177	110	21,172		
%	29.8	3.9	13.8	0.4	0.1	3.6	23.1	16.0	0.8	7.1	0.8	0.5	100		

Appendix 3.4-2: Manual Classified Traffic Count Data at Rodh El-Farag Bridge

Site : Rodh El-Farag Bridge							Code: B02								
Dir 1: Cairo							Date: 23/5/2005								
Start Hour	Number of Vehicles												Total		
	Car		Taxi		Bus				Truck					Motorcycle	
					Shared Taxi	Mini	Public	Private	Pickup	2-Axle	3-Axle	> 3 Axle			
06:00	264	313	209	29	19	93	31	36	42	37	40	44	1,157		
7:00	818	963	657	22	39	91	143	92	1	5	153	14	2,998		
8:00	1,290	836	786	1	24	16	121	95	0	1	152	77	3,399		
9:00	1,232	937	636	0	29	15	98	69	0	6	71	39	3,132		
10:00	1,286	1,073	879	5	31	11	166	52	46	14	25	16	3,604		
11:00	688	646	367	1	40	24	221	180	4	19	111	16	2,317		
12:00	488	602	265	6	38	26	497	96	23	7	207	14	2,269		
13:00	835	801	688	9	33	42	234	60	7	4	7	3	2,723		
14:00	1,263	925	855	7	28	20	199	132	6	4	81	24	3,544		
15:00	962	896	779	7	36	89	355	86	1	7	125	21	3,364		
16:00	625	613	389	0	24	162	386	139	3	6	135	8	2,490		
17:00	755	608	345	0	18	56	318	96	5	7	98	9	2,315		
18:00	664	726	447	3	19	75	492	153	5	4	175	4	2,767		
19:00	876	985	383	0	17	51	359	145	1	6	154	5	2,982		
20:00	747	666	361	0	18	37	228	110	10	2	101	1	2,281		
21:00	813	826	415	2	17	53	290	169	2	4	178	2	2,771		
Total	13,606	12,416	8,461	92	430	861	4,138	1,710	156	133	1,813	297	44,113		
%	30.8	28.1	19.2	0.2	1.0	2.0	9.4	3.9	0.4	0.3	4.1	0.7	100		

Site : Rodh El-Farag Bridge							Code: B02								
Dir 2: Giza							Date: 23/5/2005								
Start Hour	Number of Vehicles												Total		
	Car		Taxi		Bus				Truck					Motorcycle	
					Shared Taxi	Mini	Public	Private	Pickup	2-Axle	3-Axle	> 3 Axle			
06:00	180	226	197	110	61	83	58	26	3	4	6	9	963		
7:00	431	272	314	124	95	144	145	57	23	7	18	26	1,656		
8:00	455	270	335	38	52	99	145	47	11	0	27	16	1,495		
9:00	592	400	349	8	65	53	193	56	8	8	23	31	1,786		
10:00	199	331	222	34	37	24	154	239	8	23	122	65	1,458		
11:00	406	346	323	11	113	82	281	144	4	1	84	21	1,816		
12:00	476	388	301	22	162	127	317	201	13	6	42	10	2,065		
13:00	615	648	341	0	81	87	251	69	36	28	34	26	2,216		
14:00	618	475	520	39	98	126	318	187	6	8	76	8	2,479		
15:00	827	801	510	33	314	252	437	99	42	27	57	56	3,455		
16:00	688	600	424	44	70	82	372	62	7	5	102	26	2,482		
17:00	686	774	625	4	32	54	396	80	5	5	128	49	2,838		
18:00	932	1,023	826	7	72	109	391	139	8	3	64	20	3,594		
19:00	1,275	1,033	916	4	29	49	508	153	21	1	133	12	4,134		
20:00	1,327	1,349	631	0	30	95	773	190	16	18	106	37	4,572		
21:00	750	838	386	0	32	21	288	126	39	0	60	4	2,544		
Total	10,457	9,774	7,220	478	1,343	1,487	5,027	1,875	250	144	1,082	416	39,553		
%	26.4	24.7	18.3	1.2	3.4	3.8	12.7	4.7	0.6	0.4	2.7	1.1	100		

Appendix 3.4-3: Manual Classified Traffic Count Data at Imbaba Bridge

Site : Imbaba Bridge							Code: B03								
Dir 1: Cairo							Date: 23/5/2005								
Start Hour	Number of Vehicles												Total		
	Car		Taxi		Bus				Truck					Motorcycle	
					Shared Taxi	Mini	Public	Private	Pickup	2-Axle	3-Axle	> 3 Axle			
06:00	50	68	55	0	0	0	12	14	0	0	34	22	255		
7:00	120	79	96	0	0	1	16	21	0	0	87	15	435		
8:00	240	219	127	0	0	0	48	24	0	0	142	17	817		
9:00	218	214	104	0	0	0	56	31	0	0	114	9	746		
10:00	157	160	79	0	0	0	44	27	0	0	94	8	569		
11:00	143	159	63	0	0	0	49	37	0	0	76	7	534		
12:00	149	153	61	0	0	1	40	27	0	0	68	4	503		
13:00	146	153	73	0	0	0	40	28	0	0	77	12	529		
14:00	154	169	93	0	0	0	51	42	0	0	68	10	587		
15:00	137	109	79	0	0	0	51	26	0	0	47	12	461		
16:00	159	118	82	0	0	1	40	36	0	0	57	12	505		
17:00	191	157	81	0	0	3	56	42	0	0	45	5	580		
18:00	135	140	77	0	0	3	45	35	0	0	54	4	493		
19:00	131	136	79	0	0	4	36	24	1	0	66	4	481		
20:00	136	190	89	0	0	3	27	31	0	0	44	6	526		
21:00	110	151	123	0	0	0	18	22	0	0	49	6	479		
Total	2,376	2,375	1,361	0	0	16	629	467	1	0	1,122	153	8,500		
%	28.0	27.9	16.0	0.0	0.0	0.2	7.4	5.5	0.0	0.0	13.2	1.8	100		

Site : Imbaba Bridge							Code: B03								
Dir 2: Giza							Date: 23/5/2005								
Start Hour	Number of Vehicles												Total		
	Car		Taxi		Bus				Truck					Motorcycle	
					Shared Taxi	Mini	Public	Private	Pickup	2-Axle	3-Axle	> 3 Axle			
06:00	71	77	202	0	0	1	19	3	0	0	32	6	411		
7:00	33	59	365	0	0	0	14	5	0	0	25	12	513		
8:00	80	122	421	0	0	1	23	8	0	0	33	10	698		
9:00	81	158	331	2	0	0	33	7	0	0	23	15	650		
10:00	115	155	308	0	0	0	55	7	0	0	41	11	692		
11:00	136	203	241	0	0	0	54	11	0	0	49	13	707		
12:00	149	156	219	0	0	0	58	13	0	0	69	6	670		
13:00	156	205	235	0	0	0	90	13	0	0	87	11	797		
14:00	231	221	273	0	0	5	73	9	0	0	101	14	927		
15:00	276	211	261	0	0	11	94	11	0	0	121	11	996		
16:00	282	189	265	0	0	8	82	12	0	0	101	14	953		
17:00	197	193	255	0	0	0	70	11	0	0	84	6	816		
18:00	205	218	273	0	0	0	68	4	0	0	76	9	853		
19:00	210	261	311	0	0	0	69	10	0	0	93	7	961		
20:00	316	340	436	0	0	3	102	43	0	0	80	27	1,347		
21:00	239	282	343	0	0	3	83	12	0	0	109	12	1,083		
Total	2,777	3,050	4,739	2	0	32	987	179	0	0	1,124	184	13,074		
%	21.2	23.3	36.2	0.0	0.0	0.2	7.5	1.4	0.0	0.0	8.6	1.4	100		

Appendix 3.4-4: Manual Classified Traffic Count Data at 15th of May Bridge

Site : 15 th of May Bridge							Code: B04								
Dir 1: Cairo							Date: 23/5/2005								
Start Hour	Number of Vehicles												Total		
	Car		Taxi		Bus				Truck					Motorcycle	
					Shared Taxi	Mini	Public	Private	Pickup	2-Axle	3-Axle	> 3 Axle			
06:00	304	241	328	71	26	80	55	5	0	0	3	1	1,114		
7:00	1,044	654	627	69	13	145	74	5	0	0	108	1	2,740		
8:00	1,128	622	593	120	16	88	55	2	0	0	210	1	2,835		
9:00	1,013	700	762	71	16	117	70	3	0	0	115	0	2,867		
10:00	1,187	691	581	87	14	91	84	3	1	0	201	42	2,982		
11:00	1,629	849	754	167	30	126	82	11	1	0	135	3	3,787		
12:00	1,654	1,444	633	122	23	71	121	18	4	1	198	11	4,300		
13:00	2,098	1,251	402	49	20	83	95	23	7	0	176	10	4,214		
14:00	1,271	787	277	35	6	33	35	0	0	0	60	15	2,519		
15:00	1,338	701	340	41	9	25	18	0	0	0	81	22	2,575		
16:00	1,514	866	500	44	12	83	86	1	0	0	100	4	3,210		
17:00	1,506	831	477	60	9	109	125	6	0	0	94	3	3,220		
18:00	1,481	893	442	56	5	40	22	0	0	0	53	6	2,998		
19:00	1,792	861	296	53	3	24	30	0	0	0	57	5	3,121		
20:00	973	708	293	37	10	34	30	0	0	0	18	1	2,104		
21:00	1,528	856	432	17	6	11	6	0	0	0	13	1	2,870		
Total	21,460	12,955	7,737	1,099	218	1,160	988	77	13	1	1,622	126	47,456		
%	45.2	27.3	16.3	2.3	0.5	2.4	2.1	0.2	0.0	0.0	3.4	0.3	100		

Site : 15 th of May Bridge							Code: B04								
Dir 2: Giza							Date: 23/5/2005								
Start Hour	Number of Vehicles												Total		
	Car		Taxi		Bus				Truck					Motorcycle	
					Shared Taxi	Mini	Public	Private	Pickup	2-Axle	3-Axle	> 3 Axle			
06:00	591	337	155	135	47	117	76	16	2	0	12	1	1,489		
7:00	1,822	831	406	335	53	139	115	17	1	0	78	0	3,797		
8:00	2,177	1,020	324	302	34	146	212	17	0	0	87	0	4,319		
9:00	1,881	1,058	507	577	49	223	287	94	3	0	222	13	4,914		
10:00	1,438	667	601	563	78	293	570	114	12	1	222	1	4,560		
11:00	1,918	974	756	662	255	325	461	293	12	0	198	0	5,854		
12:00	2,754	1,244	754	578	231	283	586	205	0	0	227	0	6,862		
13:00	2,344	1,154	177	120	16	51	278	60	0	0	189	0	4,389		
14:00	1,845	1,196	257	162	35	54	257	32	0	0	163	0	4,001		
15:00	2,092	993	162	152	34	143	201	38	6	1	174	8	4,004		
16:00	2,606	1,286	159	101	35	134	219	36	0	0	156	0	4,732		
17:00	4,123	1,174	171	81	34	162	232	30	9	2	188	12	6,218		
18:00	1,759	1,254	139	60	25	188	309	31	1	1	177	0	3,944		
19:00	2,414	1,252	140	41	7	90	281	27	0	0	160	0	4,412		
20:00	2,061	1,257	103	82	23	71	187	19	0	0	154	1	3,958		
21:00	1,797	1,149	134	95	24	128	150	1	1	1	159	0	3,639		
Total	33,622	16,846	4,945	4,046	980	2,547	4,421	1,030	47	6	2,566	36	71,092		
%	47.3	23.7	7.0	5.7	1.4	3.6	6.2	1.4	0.1	0.0	3.6	0.1	100		

Appendix 3.4-5: Manual Classified Traffic Count Data at 6th of October Bridge

Site : 6th of October Bridge		Code: B05											
Dir 1: Cairo		Date: 23/5/2005											
Start Hour	Number of Vehicles												Total
	Car	Taxi	Bus				Truck				Motorcycle	Other	
			Shared Taxi	Mini	Public	Private	Pickup	2-Axle	3-Axle	> 3 Axle			
06:00	5,243	897	235	49	100	124	167	30	0	7	31	12	6,895
7:00	6,623	843	402	72	88	342	141	50	2	1	97	9	8,670
8:00	10,401	1,578	282	65	86	398	277	113	0	0	179	21	13,400
9:00	9,770	2,024	277	56	154	292	354	123	1	0	199	14	13,264
10:00	8,303	1,881	295	34	220	299	381	236	1	0	280	29	11,959
11:00	9,253	1,766	94	55	203	441	590	323	2	0	372	32	13,131
12:00	5,201	1,449	31	54	179	396	495	326	0	0	267	23	8,421
13:00	2,312	1,866	89	46	145	417	698	376	0	0	375	29	6,353
14:00	4,596	2,024	113	0	51	69	396	23	6	12	77	10	7,377
15:00	6,536	1,290	113	0	45	103	262	25	0	0	56	8	8,438
16:00	7,614	1,420	153	2	55	61	239	29	0	0	43	2	9,618
17:00	6,393	1,376	131	2	69	78	225	23	0	0	46	1	8,344
18:00	5,458	1,247	222	0	55	64	210	17	0	0	27	2	7,302
19:00	7,328	1,505	274	0	77	115	293	47	0	0	124	18	9,781
20:00	5,532	1,190	189	18	76	69	236	15	0	0	110	11	7,446
21:00	3,663	645	35	1	27	42	120	9	0	0	34	11	4,587
Total	104,226	23,001	2,935	454	1,630	3,310	5,084	1,765	12	20	2,317	232	144,986
%	71.9	15.9	2.0	0.3	1.1	2.3	3.5	1.2	0.0	0.0	1.6	0.2	100

Site : 6th of October Bridge		Code: B05											
Dir 2: Giza		Date: 23/5/2005											
Start Hour	Number of Vehicles												Total
	Car	Taxi	Bus				Truck				Motorcycle	Other	
			Shared Taxi	Mini	Public	Private	Pickup	2-Axle	3-Axle	> 3 Axle			
06:00	549	274	304	2	68	268	13	3	0	0	0	7	1,488
7:00	2,525	618	606	2	87	288	51	15	0	0	27	32	4,251
8:00	2,812	1,876	1,163	1	88	181	66	20	0	0	104	60	6,371
9:00	4,001	1,638	857	0	73	101	116	25	0	0	144	25	6,980
10:00	4,833	1,569	735	1	84	68	235	58	1	0	197	0	7,781
11:00	7,594	954	476	0	82	52	241	72	0	0	276	0	9,747
12:00	4,725	1,131	674	5	89	99	326	74	0	0	297	0	7,420
13:00	6,009	817	516	3	82	144	247	90	3	1	283	1	8,196
14:00	5,618	892	319	71	75	68	467	7	1	6	24	1	7,549
15:00	4,492	1,062	284	149	75	108	446	2	2	6	12	0	6,638
16:00	3,755	1,049	272	89	38	52	241	1	4	4	117	3	5,625
17:00	4,915	1,800	381	96	78	32	292	9	2	0	82	1	7,688
18:00	4,438	2,046	380	87	71	18	296	8	1	5	135	3	7,488
19:00	5,804	1,677	434	78	53	11	303	24	1	2	200	3	8,590
20:00	5,969	2,251	544	47	63	8	282	27	0	0	147	1	9,339
21:00	6,472	2,149	496	61	49	18	254	29	0	0	131	2	9,661
Total	74,511	21,803	8,441	692	1,155	1,516	3,876	464	15	24	2,176	139	114,812
%	64.9	19.0	7.4	0.6	1.0	1.3	3.4	0.4	0.0	0.0	1.9	0.1	100

Appendix 3.4-6: Manual Classified Traffic Count Data at Galaa Bridge

Site : Galaa Bridge							Code: B06								
Dir 1: Cairo							Date: 23/5/2005								
Start Hour	Number of Vehicles											Total			
	Car		Taxi		Bus				Truck				Motorcycle		
					Shared Taxi	Mini	Public	Private	Pickup	2-Axle	3-Axle				> 3 Axle
06:00	176	188	85	20	68	48	27	12	2	0	27	1	654		
7:00	883	414	126	26	92	103	37	7	0	0	77	2	1,767		
8:00	1,368	925	85	28	92	35	45	2	0	0	106	0	2,686		
9:00	1,528	1,019	114	39	82	50	56	1	0	0	60	13	2,962		
10:00	718	495	60	34	79	17	57	2	0	0	91	1	1,554		
11:00	767	636	53	29	57	12	47	6	0	0	63	2	1,672		
12:00	773	557	50	14	65	16	92	9	2	0	89	5	1,672		
13:00	842	700	36	12	67	23	100	1	0	0	98	2	1,881		
14:00	851	884	65	16	51	41	66	1	0	0	62	1	2,038		
15:00	997	724	64	21	53	42	89	2	0	0	70	2	2,064		
16:00	1,044	656	86	13	39	41	47	7	1	10	35	0	1,979		
17:00	1,069	479	46	15	35	45	54	1	0	0	37	1	1,782		
18:00	621	387	121	19	60	23	82	7	0	0	63	8	1,391		
19:00	853	553	198	211	210	60	95	0	0	0	81	0	2,261		
20:00	628	481	97	23	65	26	43	4	0	0	41	8	1,416		
21:00	530	550	47	14	40	19	47	2	1	0	31	9	1,290		
Total	13,648	9,648	1,333	534	1,155	601	984	64	6	10	1,031	55	29,069		
%	47.0	33.2	4.6	1.8	4.0	2.1	3.4	0.2	0.0	0.0	3.5	0.2	100		

Site : Galaa Bridge							Code: B06								
Dir 2: Giza							Date: 23/5/2005								
Start Hour	Number of Vehicles											Total			
	Car		Taxi		Bus				Truck				Motorcycle		
					Shared Taxi	Mini	Public	Private	Pickup	2-Axle	3-Axle				> 3 Axle
06:00	81	108	57	27	72	43	11	5	0	2	5	4	415		
7:00	383	292	118	48	76	53	5	19	0	0	16	7	1,017		
8:00	1,130	714	91	44	82	15	10	9	0	2	21	4	2,122		
9:00	1,025	675	55	26	94	18	19	10	0	0	39	11	1,972		
10:00	1,010	717	40	23	96	13	25	17	0	0	52	4	1,997		
11:00	574	676	31	36	77	21	32	21	0	0	56	7	1,531		
12:00	1,042	895	56	56	84	41	54	15	0	0	45	7	2,295		
13:00	1,208	906	70	76	196	64	104	38	0	0	136	5	2,803		
14:00	571	480	55	19	86	22	45	4	0	0	53	3	1,338		
15:00	712	518	57	20	69	55	65	2	0	0	51	5	1,554		
16:00	688	384	35	26	47	12	48	8	0	0	47	5	1,300		
17:00	539	297	187	152	140	73	48	0	1	0	60	30	1,527		
18:00	803	624	206	105	210	46	113	0	0	0	87	0	2,194		
19:00	878	618	44	17	42	13	29	2	0	0	34	3	1,680		
20:00	829	393	28	20	23	20	19	0	0	0	29	0	1,361		
21:00	688	848	73	37	31	9	16	0	0	0	24	1	1,727		
Total	12,161	9,145	1,203	732	1,425	518	643	150	1	4	755	96	26,833		
%	45.3	34.1	4.5	2.7	5.3	1.9	2.4	0.6	0.0	0.0	2.8	0.4	100		

Appendix 3.4-7: Manual Classified Traffic Count Data at Gamah Bridge

Site : Gamah Bridge							Code: B07								
Dir 1: Cairo							Date: 23/5/2005								
Start Hour	Number of Vehicles												Total		
	Car		Taxi		Bus				Truck					Motorcycle	
					Shared Taxi	Mini	Public	Private	Pickup	2-Axle	3-Axle	> 3 Axle			
06:00	161	130	36	13	46	67	40	1	0	2	23	7	526		
7:00	688	491	219	25	80	78	48	0	0	1	57	5	1,692		
8:00	1,714	1,022	310	22	91	38	67	0	0	1	91	1	3,357		
9:00	923	620	85	16	83	31	71	2	0	0	56	2	1,889		
10:00	1,085	606	70	23	78	34	63	2	0	0	36	5	2,002		
11:00	1,064	700	79	16	84	44	76	2	0	1	55	12	2,133		
12:00	1,129	588	69	30	59	18	96	3	0	0	37	3	2,032		
13:00	1,510	708	69	26	79	37	84	0	0	0	27	2	2,542		
14:00	1,210	645	48	8	49	22	75	2	0	0	44	6	2,109		
15:00	1,354	687	52	28	65	32	66	8	0	0	43	14	2,349		
16:00	1,295	599	57	23	56	28	67	7	0	0	35	16	2,183		
17:00	1,085	458	52	6	39	24	72	0	0	0	66	2	1,804		
18:00	1,042	683	68	21	52	33	88	0	0	0	40	2	2,029		
19:00	1,073	638	107	34	48	76	90	0	0	0	30	3	2,099		
20:00	1,212	687	97	34	61	36	91	0	0	0	31	10	2,259		
21:00	875	580	94	23	60	40	100	0	0	0	28	2	1,802		
Total	17,420	9,842	1,512	348	1,030	638	1,194	27	0	5	699	92	32,807		
%	53.1	30.0	4.6	1.1	3.1	1.9	3.6	0.1	0.0	0.0	2.1	0.3	100		

Site : Gamah Bridge							Code: B07								
Dir 2: Giza							Date: 23/5/2005								
Start Hour	Number of Vehicles												Total		
	Car		Taxi		Bus				Truck					Motorcycle	
					Shared Taxi	Mini	Public	Private	Pickup	2-Axle	3-Axle	> 3 Axle			
06:00	111	113	32	46	49	35	25	6	0	0	7	8	432		
7:00	632	319	49	21	74	66	50	10	0	0	25	15	1,261		
8:00	1,562	981	245	43	89	59	44	15	0	0	51	31	3,120		
9:00	1,760	1,209	518	45	68	45	47	25	0	0	50	33	3,800		
10:00	1,280	771	232	52	80	52	61	39	0	1	59	28	2,655		
11:00	1,420	1,106	495	29	61	21	100	23	0	1	72	18	3,346		
12:00	1,394	1,020	339	54	94	64	64	28	0	0	52	37	3,146		
13:00	1,488	1,221	156	66	96	70	80	31	0	0	68	28	3,304		
14:00	1,051	661	82	43	90	36	59	14	0	1	47	10	2,094		
15:00	1,140	587	163	64	109	10	133	25	1	1	91	3	2,327		
16:00	1,275	970	101	36	59	74	127	7	1	1	79	2	2,732		
17:00	1,205	875	90	26	46	39	91	20	0	0	67	6	2,465		
18:00	982	700	76	37	64	24	120	13	0	1	88	11	2,116		
19:00	995	700	86	38	72	28	94	22	0	0	79	2	2,116		
20:00	595	475	100	85	78	56	76	21	0	0	69	5	1,560		
21:00	695	455	128	98	79	69	88	18	0	0	72	8	1,710		
Total	17,585	12,163	2,892	783	1,208	748	1,259	317	2	6	976	245	38,184		
%	46.1	31.9	7.6	2.1	3.2	2.0	3.3	0.8	0.0	0.0	2.6	0.6	100		

Appendix 3.4-8: Manual Classified Traffic Count Data at Giza Bridge

Site : Giza Bridge							Code: B08								
Dir 1: Cairo							Date: 23/5/2005								
Start Hour	Number of Vehicles												Total		
	Car		Taxi		Bus				Truck					Motorcycle	
					Shared Taxi	Mini	Public	Private	Pickup	2-Axle	3-Axle	> 3 Axle			
06:00	383	232	285	3	31	207	90	58	3	2	38	43	1,375		
7:00	1,127	511	358	7	45	254	137	39	0	2	81	55	2,616		
8:00	938	530	234	0	38	59	121	32	0	1	89	19	2,061		
9:00	1,198	577	314	4	47	27	132	50	1	1	80	23	2,454		
10:00	1,041	519	259	1	43	27	150	56	2	0	61	21	2,180		
11:00	1,000	600	292	2	40	28	189	70	0	3	72	10	2,306		
12:00	1,081	434	223	2	36	24	208	81	0	0	25	9	2,123		
13:00	809	504	269	6	43	53	178	64	1	1	61	19	2,008		
14:00	1,325	1,029	326	9	28	36	242	62	0	1	43	17	3,118		
15:00	1,369	933	343	0	41	105	202	128	0	0	110	28	3,259		
16:00	1,029	742	400	3	43	101	229	132	0	2	130	39	2,850		
17:00	798	612	276	1	27	71	181	64	0	0	88	44	2,162		
18:00	1,120	720	334	0	16	80	173	60	0	0	92	25	2,620		
19:00	987	657	315	1	24	38	210	50	0	0	131	18	2,431		
20:00	944	810	378	0	29	29	196	70	0	1	86	21	2,564		
21:00	1,380	956	238	85	25	32	178	54	0	0	126	8	3,082		
Total	16,529	10,366	4,844	124	556	1,171	2,816	1,070	7	14	1,313	399	39,209		
%	42.2	26.4	12.4	0.3	1.4	3.0	7.2	2.7	0.0	0.0	3.3	1.0	100		

Site : Giza Bridge							Code: B08								
Dir 2: Giza							Date: 23/5/2005								
Start Hour	Number of Vehicles												Total		
	Car		Taxi		Bus				Truck					Motorcycle	
					Shared Taxi	Mini	Public	Private	Pickup	2-Axle	3-Axle	> 3 Axle			
06:00	312	277	411	9	42	213	55	27	6	1	17	33	1,403		
7:00	589	552	489	2	47	187	85	27	3	0	49	47	2,077		
8:00	1,074	718	260	6	20	28	53	10	0	0	57	24	2,250		
9:00	1,194	910	380	4	35	28	112	29	1	0	91	42	2,826		
10:00	1,061	868	336	1	53	22	145	54	0	2	86	25	2,653		
11:00	970	754	333	1	40	11	203	58	0	1	102	23	2,496		
12:00	1,398	810	312	1	50	20	198	52	0	1	104	23	2,969		
13:00	1,411	937	305	2	42	48	208	43	0	0	107	23	3,126		
14:00	1,145	899	292	2	52	51	154	36	0	3	110	16	2,760		
15:00	1,389	739	295	72	31	129	142	21	4	2	48	10	2,882		
16:00	1,329	859	375	94	111	88	132	56	26	17	100	44	3,231		
17:00	1,508	957	383	141	74	56	88	43	22	5	90	66	3,433		
18:00	1,153	656	270	44	15	41	100	14	1	1	48	20	2,363		
19:00	1,019	626	296	11	23	26	114	30	0	2	70	21	2,238		
20:00	1,509	1,052	319	31	38	13	129	7	0	0	101	27	3,226		
21:00	1,693	1,052	278	10	18	16	92	12	0	0	101	11	3,283		
Total	18,754	12,666	5,334	431	691	977	2,010	519	63	35	1,281	455	43,216		
%	43.4	29.3	12.3	1.0	1.6	2.3	4.7	1.2	0.1	0.1	3.0	1.1	100		

Appendix 3.4-9: Manual Classified Traffic Count Data at Moneeb Bridge

Site : Moneeb Bridge							Code: B09								
Dir 1: Cairo							Date: 23/5/2005								
Start Hour	Number of Vehicles											Total			
	Car		Taxi		Bus				Truck				Motorcycle		
					Shared Taxi	Mini	Public	Private	Pickup	2-Axle	3-Axle				> 3 Axle
06:00	289	72	149	1	5	130	99	126	24	45	18	10	968		
7:00	920	242	286	0	3	244	320	138	49	43	32	19	2,296		
8:00	1,530	374	271	4	6	209	442	217	57	40	57	14	3,221		
9:00	1,673	465	230	5	19	28	264	151	41	44	49	18	2,987		
10:00	1,366	279	261	3	16	17	254	140	32	39	50	21	2,478		
11:00	1,746	315	303	0	9	102	347	260	47	71	55	16	3,271		
12:00	2,890	390	253	0	6	241	333	192	55	50	87	19	4,516		
13:00	2,660	320	324	0	10	13	341	249	87	72	22	3	4,101		
14:00	1,903	750	80	28	12	20	107	61	46	35	7	7	3,056		
15:00	1,950	498	91	51	10	27	139	77	60	50	21	5	2,979		
16:00	1,731	469	101	45	9	15	83	73	52	52	18	3	2,651		
17:00	1,945	256	132	51	7	40	112	55	69	52	33	2	2,754		
18:00	1,923	362	124	27	2	24	106	74	36	38	20	4	2,740		
19:00	1,578	432	81	29	7	16	68	36	42	24	17	0	2,330		
20:00	1,378	327	102	20	3	20	101	31	38	24	4	1	2,049		
21:00	740	247	66	9	1	18	143	44	24	16	2	0	1,310		
Total	26,222	5,798	2,854	273	125	1,164	3,259	1,924	759	695	492	142	43,707		
%	60.0	13.3	6.5	0.6	0.3	2.7	7.5	4.4	1.7	1.6	1.1	0.3	100		

Site : Moneeb Bridge							Code: B09								
Dir 2: Giza							Date: 23/5/2005								
Start Hour	Number of Vehicles											Total			
	Car		Taxi		Bus				Truck				Motorcycle		
					Shared Taxi	Mini	Public	Private	Pickup	2-Axle	3-Axle				> 3 Axle
06:00	360	83	164	8	21	138	92	86	17	35	5	15	1,024		
7:00	1,319	282	346	2	5	278	203	122	21	31	22	13	2,644		
8:00	3,613	449	289	5	13	180	207	123	42	32	48	39	5,040		
9:00	4,620	543	366	3	20	129	300	153	15	24	36	13	6,222		
10:00	2,140	214	316	0	1	132	403	234	24	26	58	13	3,561		
11:00	2,100	1,150	290	2	6	64	357	146	55	68	33	27	4,298		
12:00	2,870	1,063	146	0	4	39	433	302	51	60	38	22	5,028		
13:00	1,390	415	171	1	5	126	389	250	52	41	53	36	2,929		
14:00	1,638	515	141	2	2	55	347	172	12	45	23	13	2,965		
15:00	1,952	523	232	5	9	143	442	257	14	33	45	34	3,689		
16:00	2,122	514	290	3	5	88	538	207	53	71	75	24	3,990		
17:00	2,300	480	348	2	5	55	543	268	39	55	55	30	4,180		
18:00	2,207	368	323	0	3	36	395	109	50	38	51	20	3,600		
19:00	2,205	392	260	0	4	23	397	286	44	60	27	18	3,716		
20:00	2,419	372	294	3	7	43	307	199	26	71	46	26	3,813		
21:00	2,340	361	368	0	5	48	342	107	16	51	18	4	3,660		
Total	35,595	7,724	4,344	36	115	1,577	5,695	3,021	531	741	633	347	60,359		
%	59.0	12.8	7.2	0.1	0.2	2.6	9.4	5.0	0.9	1.2	1.0	0.6	100		

Appendix 3.4-10: Manual Classified Traffic Count Data at Marazeeq Bridge

Site : Marazeeq Bridge							Code: B10								
Dir 1: Cairo							Date: 23/5/2005								
Start Hour	Number of Vehicles												Total		
	Car		Taxi		Bus				Truck					Motorcycle	
					Shared Taxi	Mini	Public	Private	Pickup	2-Axle	3-Axle	> 3 Axle			
Other															
06:00	45	4	83	5	17	41	45	46	9	8	1	48	352		
7:00	125	5	151	6	27	100	131	52	3	15	0	89	704		
8:00	133	2	84	1	6	35	135	80	4	7	12	50	549		
9:00	95	2	62	0	1	13	123	52	6	18	0	20	392		
10:00	85	7	64	0	0	4	154	53	3	11	1	9	391		
11:00	64	4	47	0	0	5	141	74	3	20	3	4	365		
12:00	66	7	68	0	2	8	147	57	1	19	1	2	378		
13:00	76	7	54	0	0	25	131	55	1	12	3	3	367		
14:00	73	3	70	3	1	17	160	53	3	25	1	3	412		
15:00	55	1	79	0	0	45	109	56	4	18	5	3	375		
16:00	85	2	77	0	0	38	86	49	3	13	1	5	359		
17:00	68	3	70	0	7	24	86	58	0	16	2	0	334		
18:00	77	3	77	0	1	24	80	87	4	18	5	3	379		
19:00	83	6	60	2	2	8	90	84	1	16	4	4	360		
20:00	79	2	47	0	0	5	77	84	3	7	5	1	310		
21:00	83	3	31	0	0	29	52	56	0	3	3	1	261		
Total	1,292	61	1,124	17	64	421	1,747	996	48	226	47	245	6,288		
%	20.5	1.0	17.9	0.3	1.0	6.7	27.8	15.8	0.8	3.6	0.7	3.9	100		

Site : Marazeeq Bridge							Code: B10								
Dir 2: Giza							Date: 23/5/2005								
Start Hour	Number of Vehicles												Total		
	Car		Taxi		Bus				Truck					Motorcycle	
					Shared Taxi	Mini	Public	Private	Pickup	2-Axle	3-Axle	> 3 Axle			
Other															
06:00	29	1	63	1	1	23	61	26	3	4	2	3	217		
7:00	76	0	119	2	4	37	89	44	0	14	3	3	391		
8:00	61	2	122	0	0	49	78	48	0	11	3	4	378		
9:00	59	1	92	0	0	12	104	55	3	5	6	7	344		
10:00	71	8	67	0	0	7	132	63	7	8	4	18	385		
11:00	65	3	51	0	0	5	115	56	0	23	6	9	333		
12:00	75	4	58	0	0	13	131	68	2	26	6	23	406		
13:00	91	2	43	0	0	13	148	80	7	28	6	24	442		
14:00	81	2	57	0	0	24	128	55	1	18	5	28	399		
15:00	84	6	72	0	5	82	108	69	2	35	6	27	496		
16:00	75	5	72	0	1	108	91	70	6	37	9	28	502		
17:00	71	3	71	0	0	50	87	65	1	27	5	20	400		
18:00	107	0	71	0	0	13	128	70	1	16	3	13	422		
19:00	115	2	57	0	0	23	112	58	1	18	7	13	406		
20:00	79	3	58	0	0	11	118	58	1	14	5	11	358		
21:00	68	2	50	0	0	19	86	49	9	40	2	2	327		
Total	1,207	44	1,123	3	11	489	1,716	934	44	324	78	233	6,206		
%	19.4	0.7	18.1	0.0	0.2	7.9	27.7	15.0	0.7	5.2	1.3	3.8	100		

Appendix 3.4-11: Manual Classified Traffic Count Data at 26th of July Corridor

Site : 26 th of July Corridor							Code: A18								
Dir 1: Lebanon Sq.							Date: 24/5/2005								
Start Hour	Number of Vehicles												Total		
	Car		Taxi		Bus				Truck					Motorcycle	
					Shared Taxi	Mini	Public	Private	Pickup	2-Axle	3-Axle	> 3 Axle			
Other															
06:00	280	64	217	0	7	62	22	24	0	1	1	2	680		
7:00	1,651	201	501	0	11	88	32	17	0	0	11	3	2,515		
8:00	3,260	142	371	1	11	64	50	3	0	0	31	13	3,946		
9:00	3,223	171	323	2	18	62	32	11	0	0	13	4	3,859		
10:00	3,285	180	332	0	22	38	48	9	5	0	10	0	3,929		
11:00	1,980	162	299	0	19	29	43	19	1	0	12	2	2,566		
12:00	1,890	218	236	0	11	29	31	8	0	0	1	5	2,429		
13:00	2,120	214	211	2	21	46	50	10	2	0	14	7	2,697		
14:00	1,623	160	239	1	27	67	9	11	0	0	3	1	2,141		
15:00	2,030	249	172	3	15	89	18	11	0	0	1	0	2,588		
16:00	3,405	314	321	21	15	104	12	5	0	0	2	5	4,204		
17:00	2,475	126	377	5	14	244	22	10	2	0	7	2	3,284		
18:00	2,112	66	282	2	12	131	15	3	2	0	8	0	2,633		
19:00	1,743	139	248	0	15	128	30	7	0	0	16	0	2,326		
20:00	1,575	110	244	0	16	110	42	9	1	0	9	0	2,116		
21:00	940	66	91	0	6	34	29	12	0	1	4	0	1,183		
Total	33,592	2,582	4,464	37	240	1,325	485	169	13	2	143	44	43,096		
%	77.9	6.0	10.4	0.1	0.6	3.1	1.1	0.4	0.0	0.0	0.3	0.1	100		

Site : 26 th of July Corridor							Code: A18								
Dir 2: 6 th of October City							Date: 24/5/2005								
Start Hour	Number of Vehicles												Total		
	Car		Taxi		Bus				Truck					Motorcycle	
					Shared Taxi	Mini	Public	Private	Pickup	2-Axle	3-Axle	> 3 Axle			
Other															
06:00	385	31	150	44	30	63	76	10	6	8	3	1	807		
7:00	1,415	79	314	7	27	330	89	28	1	2	1	1	2,294		
8:00	1,998	126	379	1	20	237	146	19	0	10	4	0	2,940		
9:00	2,250	140	207	2	25	48	117	28	5	5	12	0	2,839		
10:00	2,565	144	199	36	20	4	153	32	19	1	3	0	3,176		
11:00	2,265	130	224	20	20	15	134	36	14	0	13	4	2,875		
12:00	1,455	169	176	31	26	11	145	30	3	0	21	0	2,067		
13:00	1,221	222	208	57	32	10	138	38	7	1	20	0	1,954		
14:00	1,130	219	230	50	13	6	171	37	3	2	12	0	1,873		
15:00	1,707	194	229	77	34	6	171	31	4	6	25	0	2,484		
16:00	1,433	261	240	55	18	23	137	27	2	8	14	0	2,218		
17:00	1,290	222	329	71	29	26	189	51	5	0	10	2	2,224		
18:00	1,440	124	263	18	17	29	127	37	6	0	20	2	2,083		
19:00	1,090	156	224	73	19	12	104	29	7	0	28	0	1,742		
20:00	1,100	305	259	45	21	12	93	37	3	1	11	0	1,887		
21:00	1,140	196	282	71	19	7	100	43	5	2	15	0	1,880		
Total	23,884	2,718	3,913	658	370	839	2,090	513	90	46	212	10	35,343		
%	67.6	7.7	11.1	1.9	1.0	2.4	5.9	1.5	0.3	0.1	0.6	0.0	100		

Appendix 3.4-12: Manual Classified Traffic Count Data at Suez Desert Road

Site : Suez Desert Road							Code: A21								
Dir 1: Suez							Date: 24/5/2005								
Start Hour	Number of Vehicles												Total		
	Car		Taxi		Bus				Truck					Motorcycle	
					Shared Taxi	Mini	Public	Private	Pickup	2-Axle	3-Axle	> 3 Axle			
06:00	170	7	48	1	3	57	29	21	9	11	1	9	366		
7:00	706	29	261	5	4	142	68	15	2	4	6	22	1,264		
8:00	998	54	384	1	3	99	90	13	8	8	5	29	1,692		
9:00	968	31	44	0	10	62	61	19	1	6	12	25	1,239		
10:00	802	29	31	0	8	27	79	21	0	9	10	43	1,059		
11:00	705	38	33	0	11	42	76	35	1	7	9	13	970		
12:00	610	17	34	6	0	35	77	20	0	9	6	9	823		
13:00	537	17	42	0	3	32	72	13	3	9	3	3	734		
14:00	638	18	34	1	2	38	71	17	2	6	3	6	836		
15:00	1,095	24	72	0	8	47	76	30	1	27	5	0	1,385		
16:00	1,036	24	44	0	4	72	68	33	0	13	3	5	1,302		
17:00	1,013	25	17	0	7	50	68	23	0	8	2	10	1,223		
18:00	989	15	23	0	7	29	61	33	0	3	2	9	1,171		
19:00	910	17	18	0	3	49	56	16	1	14	3	8	1,095		
20:00	818	18	20	0	4	21	49	9	3	12	0	4	958		
21:00	828	7	26	0	2	20	43	12	0	27	2	1	968		
Total	12,823	370	1,131	14	79	822	1,044	330	31	173	72	196	17,085		
%	75.1	2.2	6.6	0.1	0.5	4.8	6.1	1.9	0.2	1.0	0.4	1.1	100		

Site : Suez Desert Road							Code: A21								
Dir 2: Cairo							Date: 24/5/2005								
Start Hour	Number of Vehicles												Total		
	Car		Taxi		Bus				Truck					Motorcycle	
					Shared Taxi	Mini	Public	Private	Pickup	2-Axle	3-Axle	> 3 Axle			
06:00	179	10	34	1	34	31	21	12	1	11	2	25	361		
7:00	1,007	23	64	1	13	94	33	24	3	3	3	9	1,277		
8:00	1,335	20	53	1	2	54	37	9	5	14	4	6	1,540		
9:00	751	15	53	1	1	36	62	20	2	5	9	11	966		
10:00	729	37	67	0	0	28	89	44	8	3	7	19	1,031		
11:00	762	45	141	0	5	43	73	31	8	7	8	30	1,153		
12:00	823	44	166	0	4	67	88	44	10	11	5	16	1,278		
13:00	940	25	44	2	9	106	92	43	1	14	6	23	1,305		
14:00	1,001	26	52	2	4	114	82	38	3	4	4	39	1,369		
15:00	1,429	28	44	0	7	157	108	29	1	2	7	39	1,851		
16:00	769	25	69	0	1	100	86	20	0	6	6	14	1,096		
17:00	665	26	38	1	2	93	62	21	4	3	4	8	927		
18:00	888	10	57	0	5	41	77	25	0	13	10	1	1,127		
19:00	922	14	41	0	3	36	83	25	0	21	5	0	1,150		
20:00	1,115	16	19	0	8	50	59	25	3	11	0	5	1,311		
21:00	893	14	16	0	6	32	42	20	2	9	2	3	1,039		
Total	14,208	378	958	9	104	1,082	1,094	430	51	137	82	248	18,781		
%	75.7	2.0	5.1	0.0	0.6	5.8	5.8	2.3	0.3	0.7	0.4	1.3	100		

Appendix 3.4-13: Manual Classified Traffic Count Data at Alex. Agriculture Road

Site : Alex. Agriculture Road							Code: A35								
Dir 1: Alexandria							Date: 24/5/2005								
Start Hour	Number of Vehicles												Total		
	Car		Taxi		Bus				Truck					Motorcycle	
					Shared Taxi	Mini	Public	Private	Pickup	2-Axle	3-Axle	> 3 Axle			
06:00	189	48	342	20	27	68	196	241	6	141	9	0	1,287		
7:00	506	30	706	106	30	66	246	263	5	103	18	0	2,079		
8:00	966	30	920	156	45	26	290	237	6	97	36	2	2,811		
9:00	1,101	42	728	152	56	18	301	260	2	98	14	2	2,774		
10:00	1,117	50	724	150	52	16	364	373	2	66	19	0	2,933		
11:00	965	76	691	145	47	13	403	499	5	89	23	1	2,957		
12:00	920	85	761	122	63	16	377	427	2	87	16	0	2,876		
13:00	966	80	710	126	61	33	371	390	6	83	16	3	2,845		
14:00	683	60	732	104	43	22	368	421	6	80	26	3	2,548		
15:00	571	61	906	165	110	68	481	504	7	101	31	1	3,006		
16:00	913	72	998	161	139	155	869	344	130	125	49	20	3,975		
17:00	789	95	807	153	97	76	348	131	66	246	32	33	2,873		
18:00	738	171	807	88	75	79	535	209	142	171	8	2	3,025		
19:00	587	200	803	102	75	78	432	382	37	141	24	4	2,865		
20:00	519	161	769	128	79	38	444	379	44	169	17	10	2,757		
21:00	550	96	600	122	48	52	328	158	117	246	12	19	2,348		
Total	12,080	1,357	12,004	2,000	1,047	824	6,353	5,218	583	2,043	350	100	43,959		
%	27.5	3.1	27.3	4.5	2.4	1.9	14.5	11.9	1.3	4.6	0.8	0.2	100		

Site : Alex. Agriculture Road							Code: A35								
Dir 2: Cairo							Date: 24/5/2005								
Start Hour	Number of Vehicles												Total		
	Car		Taxi		Bus				Truck					Motorcycle	
					Shared Taxi	Mini	Public	Private	Pickup	2-Axle	3-Axle	> 3 Axle			
06:00	266	48	918	0	18	737	213	306	87	167	38	0	2,798		
7:00	687	92	1,268	0	36	842	246	328	76	124	80	1	3,780		
8:00	953	144	1,076	1	71	197	479	354	108	138	95	5	3,621		
9:00	992	71	977	0	70	129	558	288	101	101	58	1	3,346		
10:00	923	69	742	2	52	91	435	296	7	83	32	17	2,749		
11:00	708	56	669	0	61	82	366	254	15	116	21	9	2,357		
12:00	682	70	537	0	61	98	369	245	6	121	31	0	2,220		
13:00	775	75	512	2	42	141	321	207	7	71	26	1	2,180		
14:00	933	96	381	0	34	131	405	167	74	78	26	22	2,347		
15:00	601	49	575	1	64	181	444	179	114	124	20	10	2,362		
16:00	599	26	565	0	56	144	617	297	160	182	7	2	2,655		
17:00	1,144	183	568	0	51	146	673	336	124	147	15	2	3,389		
18:00	892	145	738	1	84	288	541	471	31	152	1	2	3,346		
19:00	956	105	621	0	40	168	371	464	3	99	1	2	2,830		
20:00	1,210	187	531	0	64	159	290	332	3	74	10	1	2,861		
21:00	656	87	586	9	67	147	306	342	6	48	24	2	2,280		
Total	12,977	1,503	11,264	16	871	3,681	6,634	4,866	922	1,825	485	77	45,121		
%	28.8	3.3	25.0	0.0	1.9	8.2	14.7	10.8	2.0	4.0	1.1	0.2	100		

Appendix 3.4-14: Manual Classified Traffic Count Data at Ismailia Agriculture Road

Site : Ismailia Agriculture Road							Code: A36									
Dir 1: Ismailia							Date: 25/5/2005									
Start Hour	Number of Vehicles												Total			
	Car		Taxi		Bus				Truck					Motorcycle		Other
					Shared Taxi	Mini	Public	Private	Pickup	2-Axle	3-Axle	> 3 Axle				
06:00	27	9	73	0	32	11	55	39	1	17	3	1	268			
7:00	82	38	165	2	80	16	104	44	2	15	5	6	559			
8:00	175	36	210	2	46	22	154	60	1	15	22	8	751			
9:00	183	45	139	0	24	21	168	78	1	12	19	7	697			
10:00	146	46	123	1	23	4	168	106	2	12	12	7	650			
11:00	158	65	115	1	17	2	220	140	4	7	18	10	757			
12:00	140	65	102	1	11	5	216	135	0	12	27	7	721			
13:00	140	47	100	4	15	1	223	89	0	11	29	6	665			
14:00	189	41	99	5	12	12	196	113	0	30	27	6	730			
15:00	200	36	173	1	69	26	294	142	3	23	40	12	1,019			
16:00	220	64	193	1	110	60	276	290	12	26	30	8	1,290			
17:00	256	28	189	1	33	55	248	142	3	37	24	10	1,026			
18:00	281	31	235	0	17	31	296	140	0	15	26	5	1,077			
19:00	188	57	236	0	26	24	320	181	5	31	16	8	1,092			
20:00	211	36	275	1	14	19	300	258	0	84	31	12	1,241			
21:00	203	10	260	0	4	11	268	238	0	70	12	4	1,080			
Total	2,799	654	2,687	20	533	320	3,506	2,195	34	417	341	117	13,623			
%	20.5	4.8	19.7	0.1	3.9	2.3	25.7	16.1	0.2	3.1	2.5	0.9	100			

Site : Ismailia Agriculture Road							Code: A36									
Dir 2: Cairo							Date: 25/5/2005									
Start Hour	Number of Vehicles												Total			
	Car		Taxi		Bus				Truck					Motorcycle		Other
					Shared Taxi	Mini	Public	Private	Pickup	2-Axle	3-Axle	> 3 Axle				
06:00	74	32	106	70	82	10	76	119	15	41	23	15	663			
7:00	188	72	230	31	93	4	236	99	2	17	60	35	1,067			
8:00	150	87	165	4	21	5	211	97	4	3	44	15	806			
9:00	172	80	155	3	12	2	259	105	4	14	32	6	844			
10:00	162	66	173	0	15	1	198	92	6	6	41	5	765			
11:00	144	51	123	1	5	0	220	109	6	11	23	9	702			
12:00	124	64	84	0	9	1	224	87	5	14	33	5	650			
13:00	134	57	100	3	14	0	168	72	10	13	18	9	598			
14:00	145	55	103	7	17	2	168	99	4	25	25	12	662			
15:00	195	43	100	4	44	16	186	130	3	13	30	6	770			
16:00	186	77	185	15	39	10	183	167	7	21	30	10	930			
17:00	171	55	212	11	40	18	255	126	1	24	25	17	955			
18:00	196	71	163	16	29	20	210	122	2	9	22	9	869			
19:00	194	95	181	0	40	26	240	182	4	19	33	9	1,023			
20:00	220	80	205	13	44	65	220	200	70	86	30	22	1,255			
21:00	240	26	161	8	18	37	229	143	14	86	14	11	987			
Total	2,695	1,011	2,446	186	522	217	3,283	1,949	157	402	483	195	13,546			
%	19.9	7.5	18.1	1.4	3.9	1.6	24.2	14.4	1.2	3.0	3.6	1.4	100			

Appendix 3.4-15: Manual Classified Traffic Count Data at Ismailia Desert Road

Site : Ismailia Desert Road							Code: A39									
Dir 1: Ismailia							Date: 25/5/2005									
Start Hour	Number of Vehicles												Total			
	Car		Taxi		Bus				Truck					Motorcycle		Other
					Shared Taxi	Mini	Public	Private	Pickup	2-Axle	3-Axle	> 3 Axle				
06:00	396	27	398	2	72	61	89	91	17	56	0	16	1,225			
7:00	543	5	569	0	130	138	253	299	32	74	0	9	2,052			
8:00	1,540	242	545	1	180	291	361	330	30	80	7	6	3,613			
9:00	2,030	137	380	0	162	281	315	269	111	125	5	17	3,832			
10:00	1,660	70	191	0	91	173	206	190	71	66	2	6	2,726			
11:00	1,600	116	182	1	47	63	385	236	79	43	6	6	2,764			
12:00	1,050	89	124	0	29	62	461	296	57	77	3	23	2,271			
13:00	900	160	139	0	56	74	475	359	12	44	2	10	2,231			
14:00	640	78	239	0	105	133	505	328	14	54	12	31	2,139			
15:00	913	58	333	0	70	79	465	354	34	74	12	26	2,418			
16:00	634	82	258	1	35	12	413	400	30	85	4	26	1,980			
17:00	1,186	117	396	0	40	61	395	370	15	50	3	18	2,651			
18:00	1,864	89	290	0	31	56	389	269	13	47	9	6	3,063			
19:00	1,025	51	302	1	61	62	305	231	17	31	4	12	2,102			
20:00	1,420	17	283	0	26	42	206	172	32	41	7	12	2,258			
21:00	1,220	17	33	0	23	40	148	90	22	36	0	6	1,635			
Total	18,621	1,355	4,662	6	1,158	1,628	5,371	4,284	586	983	76	230	38,960			
%	47.8	3.5	12.0	0.0	3.0	4.2	13.8	11.0	1.5	2.5	0.2	0.6	100			

Site : Ismailia Desert Road							Code: A39									
Dir 2: Cairo							Date: 25/5/2005									
Start Hour	Number of Vehicles												Total			
	Car		Taxi		Bus				Truck					Motorcycle		Other
					Shared Taxi	Mini	Public	Private	Pickup	2-Axle	3-Axle	> 3 Axle				
06:00	281	75	174	1	11	55	94	129	8	43	2	36	909			
7:00	883	96	563	1	36	4	266	142	15	47	2	38	2,093			
8:00	1,293	93	669	0	79	46	360	128	30	87	14	18	2,817			
9:00	921	66	522	0	88	72	420	203	25	108	5	17	2,447			
10:00	1,130	325	586	0	95	111	410	380	68	86	4	18	3,213			
11:00	1,216	78	353	1	37	21	567	731	86	204	2	3	3,299			
12:00	1,456	94	416	1	24	24	535	589	68	85	4	1	3,297			
13:00	1,528	61	489	0	51	103	501	533	32	26	4	0	3,328			
14:00	877	79	296	0	59	51	453	756	43	46	1	0	2,661			
15:00	1,205	83	244	0	32	25	408	434	10	61	2	2	2,506			
16:00	886	80	300	0	62	97	522	691	42	71	1	8	2,760			
17:00	1,001	40	216	1	55	88	470	244	35	87	4	1	2,242			
18:00	577	35	154	0	39	80	484	367	70	90	0	8	1,904			
19:00	1,165	93	161	0	37	59	440	383	22	62	2	2	2,426			
20:00	1,001	113	217	0	46	138	507	447	59	45	1	8	2,582			
21:00	791	40	142	0	71	84	462	390	31	77	1	1	2,090			
Total	16,211	1,451	5,502	5	822	1,058	6,899	6,547	644	1,225	49	161	40,574			
%	40.0	3.6	13.6	0.0	2.0	2.6	17.0	16.1	1.6	3.0	0.1	0.4	100			

Appendix 3.4-16: Manual Classified Traffic Count Data at Autostrade

Site : Autostrade							Code: A42									
Dir 1: Cairo Airoport							Date: 30/5/2005									
Start Hour	Number of Vehicles												Total			
	Car		Taxi		Bus				Truck					Motorcycle		Other
					Shared Taxi	Mini	Public	Private	Pickup	2-Axle	3-Axle	> 3 Axle				
06:00	411	74	289	0	4	16	146	127	14	113	0	0	1,194			
7:00	534	77	382	0	3	13	99	102	60	108	5	11	1,394			
8:00	816	76	179	0	5	50	108	95	53	41	9	11	1,443			
9:00	516	222	191	0	4	10	80	88	20	28	1	2	1,162			
10:00	363	48	120	0	0	2	88	137	13	37	5	9	822			
11:00	312	36	73	0	1	0	106	125	16	32	2	14	717			
12:00	401	53	97	0	1	8	94	123	7	51	1	8	844			
13:00	380	49	188	0	1	5	86	97	20	42	2	7	877			
14:00	318	80	91	0	1	5	64	118	9	54	1	3	744			
15:00	271	57	87	1	3	8	107	72	1	74	5	9	695			
16:00	261	47	91	0	1	40	105	70	11	65	0	7	698			
17:00	350	67	136	1	3	25	117	84	3	87	4	1	878			
18:00	331	37	106	0	1	17	106	95	0	133	3	0	829			
19:00	296	48	113	0	1	4	85	102	6	165	2	0	822			
20:00	235	56	96	1	0	2	84	65	0	108	5	2	654			
21:00	247	36	84	0	2	0	60	113	49	81	0	0	672			
Total	6,042	1,063	2,323	3	31	205	1,535	1,613	282	1,219	45	84	14,445			
%	41.8	7.4	16.1	0.0	0.2	1.4	10.6	11.2	2.0	8.4	0.3	0.6	100			

Site : Autostrade							Code: A42									
Dir 2: Helwan							Date: 30/5/2005									
Start Hour	Number of Vehicles												Total			
	Car		Taxi		Bus				Truck					Motorcycle		Other
					Shared Taxi	Mini	Public	Private	Pickup	2-Axle	3-Axle	> 3 Axle				
06:00	247	36	84	0	2	0	60	113	49	81	0	0	672			
7:00	393	51	168	1	1	15	83	101	63	47	0	6	929			
8:00	454	60	214	0	0	17	80	132	26	76	7	5	1,071			
9:00	244	41	131	0	3	18	135	188	26	55	7	5	853			
10:00	341	49	155	3	3	9	148	181	20	53	6	10	978			
11:00	346	71	148	0	0	15	92	137	14	102	5	3	933			
12:00	333	71	90	0	3	19	135	161	20	84	4	12	932			
13:00	426	82	126	0	2	1	116	109	5	63	21	1	952			
14:00	415	59	144	0	5	13	121	106	11	123	3	12	1,012			
15:00	478	70	163	0	8	46	104	94	16	91	6	21	1,097			
16:00	438	54	173	0	4	72	155	242	11	115	0	2	1,266			
17:00	648	124	225	0	3	69	104	356	9	87	4	0	1,629			
18:00	799	68	333	0	4	74	134	476	17	93	15	5	2,018			
19:00	411	67	217	0	6	17	117	279	13	85	2	0	1,214			
20:00	359	70	145	0	5	25	133	207	20	98	2	0	1,064			
21:00	527	77	432	0	4	8	128	133	62	135	4	4	1,514			
Total	6,859	1,050	2,948	4	53	418	1,845	3,015	382	1,388	86	86	18,134			
%	37.8	5.8	16.3	0.0	0.3	2.3	10.2	16.6	2.1	7.7	0.5	0.5	100			

Appendix 3.4-17: Manual Classified Traffic Count Data at Nasr Road (Autostrade)

Site : Nasr Road (Autostrade)							Code: AC20									
Dir 1: Cairo Airport							Date: 30/5/2005									
Start Hour	Number of Vehicles												Total			
	Car		Taxi		Bus				Truck					Motorcycle		Other
					Shared Taxi	Mini	Public	Private	Pickup	2-Axle	3-Axle	> 3 Axle				
06:00	548	267	306	49	145	316	136	64	18	51	20	57	1,977			
7:00	2,488	989	645	50	213	228	200	74	1	7	76	43	5,014			
8:00	4,799	1,446	808	109	125	315	213	88	15	11	106	15	8,050			
9:00	3,023	1,815	736	146	178	29	405	11	10	4	12	38	6,407			
10:00	4,093	1,215	696	159	215	107	233	146	26	4	75	42	7,011			
11:00	3,484	1,182	1,174	151	198	16	635	162	16	3	31	20	7,072			
12:00	3,373	1,117	1,190	167	264	18	1,078	52	11	1	71	22	7,364			
13:00	3,142	1,158	988	200	300	126	616	83	20	2	101	28	6,764			
14:00	3,131	829	542	38	133	180	210	66	4	8	60	10	5,211			
15:00	3,120	975	587	31	103	420	266	69	0	8	52	2	5,633			
16:00	3,543	942	701	37	119	150	235	125	4	12	0	0	5,868			
17:00	3,202	932	822	37	136	82	332	109	4	13	0	0	5,669			
18:00	2,999	1,004	786	49	112	63	470	126	0	15	0	0	5,624			
19:00	3,270	1,011	760	50	141	21	324	112	3	26	9	4	5,731			
20:00	2,391	884	638	51	111	26	312	91	1	17	30	4	4,556			
21:00	2,666	907	558	34	112	78	258	37	0	19	38	16	4,723			
Total	49,272	16,673	11,937	1,358	2,605	2,175	5,923	1,415	133	201	681	301	92,674			
%	53.2	18.0	12.9	1.5	2.8	2.3	6.4	1.5	0.1	0.2	0.7	0.3	100			

Site : Nasr Road (Autostrade)							Code: AC20									
Dir 2: Helwan							Date: 30/5/2005									
Start Hour	Number of Vehicles												Total			
	Car		Taxi		Bus				Truck					Motorcycle		Other
					Shared Taxi	Mini	Public	Private	Pickup	2-Axle	3-Axle	> 3 Axle				
06:00	462	341	242	3	129	188	121	87	21	13	22	58	1,687			
7:00	1,787	686	268	7	210	662	168	50	4	1	66	133	4,042			
8:00	2,736	1,093	402	57	373	272	206	98	0	2	39	75	5,353			
9:00	3,596	1,120	451	107	381	143	251	129	1	12	47	67	6,305			
10:00	3,110	998	556	234	508	89	261	166	5	14	42	48	6,031			
11:00	2,590	1,209	641	398	749	51	359	187	11	13	46	31	6,285			
12:00	2,867	1,067	811	416	496	89	480	171	16	8	68	40	6,529			
13:00	2,860	1,334	630	322	315	47	331	269	6	10	50	32	6,206			
14:00	1,385	908	371	143	271	166	316	147	1	2	90	33	3,833			
15:00	2,153	1,016	420	170	136	310	351	93	2	3	57	50	4,761			
16:00	1,805	865	550	159	196	280	353	226	3	4	73	63	4,577			
17:00	1,402	821	508	143	252	196	282	194	3	1	56	58	3,916			
18:00	2,625	1,424	554	168	219	107	403	153	6	1	57	39	5,756			
19:00	2,162	981	565	72	145	57	391	134	0	3	86	63	4,659			
20:00	1,640	731	250	41	86	44	289	58	2	0	49	23	3,213			
21:00	1,500	937	629	129	209	45	294	53	0	1	61	29	3,887			
Total	34,680	15,531	7,848	2,569	4,675	2,746	4,856	2,215	81	88	909	842	77,040			
%	45.0	20.2	10.2	3.3	6.1	3.6	6.3	2.9	0.1	0.1	1.2	1.1	100			

Appendix 3.4-18: Manual Classified Traffic Count Data at Gesr El-Suez St.

Site : Gesr El-Suez St.							Code: NW01									
Dir 1: Ismailia							Date: 24/5/2005									
Start Hour	Number of Vehicles												Total			
	Car		Taxi		Bus				Truck					Motorcycle		Other
					Shared Taxi	Mini	Public	Private	Pickup	2-Axle	3-Axle	> 3 Axle				
06:00	390	123	169	4	53	104	172	35	8	2	15	10	1,085			
7:00	573	277	360	0	81	200	212	25	18	11	46	15	1,818			
8:00	683	333	477	0	159	300	120	19	8	19	64	51	2,233			
9:00	464	207	464	0	140	154	248	36	24	17	49	26	1,829			
10:00	405	195	672	0	127	134	211	54	22	16	45	46	1,927			
11:00	799	249	278	10	57	13	309	210	14	8	30	18	1,995			
12:00	993	247	279	3	62	40	387	179	8	15	25	25	2,263			
13:00	1,030	412	265	10	36	10	328	146	7	28	18	10	2,300			
14:00	1,191	365	160	2	40	152	308	107	6	12	41	11	2,395			
15:00	1,330	367	195	1	50	153	299	158	4	10	26	26	2,619			
16:00	1,207	354	208	1	39	113	327	231	5	8	50	16	2,559			
17:00	1,492	180	198	2	41	51	266	83	9	6	34	15	2,377			
18:00	1,250	291	212	1	34	62	260	89	2	9	43	10	2,263			
19:00	1,325	172	187	3	46	54	185	78	7	9	30	13	2,109			
20:00	982	338	182	0	39	24	196	88	2	5	32	7	1,895			
21:00	1,175	523	148	0	36	28	193	72	4	11	30	10	2,230			
Total	15,289	4,633	4,454	37	1,040	1,592	4,021	1,610	148	186	578	309	33,897			
%	45.1	13.7	13.1	0.1	3.1	4.7	11.9	4.7	0.4	0.5	1.7	0.9	100			

Site : Gesr El-Suez St.							Code: NW01									
Dir 2: CBD							Date: 24/5/2005									
Start Hour	Number of Vehicles												Total			
	Car		Taxi		Bus				Truck					Motorcycle		Other
					Shared Taxi	Mini	Public	Private	Pickup	2-Axle	3-Axle	> 3 Axle				
06:00	342	203	225	30	64	174	114	31	9	5	15	13	1,225			
7:00	638	227	258	15	54	131	80	44	8	9	4	56	1,524			
8:00	619	219	308	13	65	150	169	80	10	9	15	15	1,672			
9:00	555	211	277	6	53	51	238	133	7	5	22	11	1,569			
10:00	554	239	201	5	41	23	261	166	4	9	26	11	1,540			
11:00	641	279	195	5	55	34	286	139	4	14	31	12	1,695			
12:00	722	310	219	5	40	49	290	169	4	9	49	16	1,882			
13:00	635	340	201	6	57	63	239	124	6	9	27	15	1,722			
14:00	820	491	152	64	87	17	422	196	20	7	52	21	2,349			
15:00	1,105	738	526	5	44	105	473	209	73	20	40	8	3,346			
16:00	1,173	890	140	63	58	56	165	62	13	19	49	23	2,711			
17:00	729	483	261	12	34	28	282	166	26	16	36	12	2,085			
18:00	789	312	356	3	18	33	369	115	21	20	74	10	2,120			
19:00	1,269	628	421	1	38	41	597	132	23	16	49	21	3,236			
20:00	1,228	756	283	57	67	35	279	74	7	7	42	6	2,841			
21:00	684	325	452	0	18	25	396	67	9	6	50	8	2,040			
Total	12,503	6,651	4,475	290	793	1,015	4,660	1,907	244	180	581	258	33,557			
%	37.3	19.8	13.3	0.9	2.4	3.0	13.9	5.7	0.7	0.5	1.7	0.8	100			

Appendix 3.4-19: Manual Classified Traffic Count Data at Suez Desert Road

Site : Suez Desert Road							Code: NW02						
Dir 1: Suez							Date: 25/5/2005						
Start Hour	Number of Vehicles												Total
	Car	Taxi	Bus				Truck				Motorcycle	Other	
			Shared Taxi	Mini	Public	Private	Pickup	2-Axle	3-Axle	> 3 Axle			
06:00	245	53	65	6	10	68	39	30	8	2	12	14	552
7:00	1,248	108	137	5	16	381	93	33	5	3	20	21	2,070
8:00	1,361	161	106	21	14	110	96	31	3	11	2	17	1,933
9:00	1,433	166	74	4	11	91	86	34	3	4	18	7	1,931
10:00	1,017	261	142	5	10	38	156	67	5	3	11	8	1,723
11:00	1,079	144	64	5	10	51	141	44	8	4	22	14	1,586
12:00	1,388	153	77	5	5	56	114	41	12	7	14	14	1,886
13:00	975	142	74	10	10	70	121	39	4	4	25	7	1,481
14:00	945	137	58	9	12	63	153	40	3	4	20	5	1,449
15:00	1,115	133	69	6	7	71	120	36	1	5	19	10	1,592
16:00	1,065	142	61	7	15	110	132	58	4	5	27	14	1,640
17:00	1,339	193	72	7	5	82	105	46	0	6	25	7	1,887
18:00	1,502	185	91	7	14	74	127	25	0	1	18	4	2,048
19:00	1,380	130	79	6	10	51	78	30	2	5	28	4	1,803
20:00	1,849	171	69	3	11	31	85	20	3	3	9	4	2,258
21:00	1,319	145	86	5	11	27	69	12	1	0	8	3	1,686
Total	19,260	2,424	1,324	111	171	1,374	1,715	586	62	67	278	153	27,525
%	70.0	8.8	4.8	0.4	0.6	5.0	6.2	2.1	0.2	0.2	1.0	0.6	100

Site : Suez Desert Road							Code: NW02						
Dir 2: Cairo							Date: 25/5/2005						
Start Hour	Number of Vehicles												Total
	Car	Taxi	Bus				Truck				Motorcycle	Other	
			Shared Taxi	Mini	Public	Private	Pickup	2-Axle	3-Axle	> 3 Axle			
06:00	131	36	58	22	14	75	16	19	6	5	2	16	400
7:00	805	158	147	28	53	88	42	61	15	2	8	18	1,425
8:00	1,380	99	97	5	21	84	44	78	0	5	4	1	1,818
9:00	920	230	140	4	14	53	55	47	8	2	7	2	1,482
10:00	1,121	217	118	6	11	42	106	41	21	2	21	0	1,706
11:00	876	137	128	16	15	44	112	45	15	4	13	11	1,416
12:00	786	205	157	4	17	59	100	64	5	4	4	12	1,417
13:00	636	130	105	4	9	68	81	37	1	3	7	11	1,092
14:00	621	196	130	33	11	36	89	17	25	5	16	15	1,194
15:00	1,060	311	180	66	12	41	145	27	16	6	15	10	1,889
16:00	988	417	228	88	37	75	181	51	27	3	23	2	2,120
17:00	688	338	223	104	27	47	162	70	23	15	31	19	1,747
18:00	820	370	250	82	19	46	165	53	23	13	33	6	1,880
19:00	680	275	175	71	19	57	140	35	20	5	21	9	1,507
20:00	501	150	145	63	16	42	102	25	12	6	23	18	1,103
21:00	778	215	265	169	89	113	260	77	92	23	42	28	2,151
Total	12,791	3,484	2,546	765	384	970	1,800	747	309	103	270	178	24,347
%	52.5	14.3	10.5	3.1	1.6	4.0	7.4	3.1	1.3	0.4	1.1	0.7	100

Appendix 3.4-20: Manual Classified Traffic Count Data at Abo Bakr El-Sedeeq St.

Site : Abo Bakr El-Sedeeq St.							Code: NW03									
Dir 1: Orooba St.							Date: 24/5/2005									
Start Hour	Number of Vehicles												Total			
	Car		Taxi		Bus				Truck					Motorcycle		Other
					Shared Taxi	Mini	Public	Private	Pickup	2-Axle	3-Axle	> 3 Axle				
06:00	148	56	40	12	12	32	4	4	12	0	4	0	324			
7:00	344	228	65	24	42	34	47	0	1	0	31	6	822			
8:00	721	426	90	10	50	40	72	3	0	1	32	4	1,449			
9:00	848	499	107	0	45	47	97	2	0	1	55	7	1,708			
10:00	811	637	185	30	92	51	196	20	6	2	118	14	2,162			
11:00	1,104	772	110	63	87	71	162	12	1	2	38	13	2,435			
12:00	1,320	830	160	56	91	78	115	20	13	10	47	13	2,753			
13:00	1,230	785	127	42	67	56	103	35	21	3	35	12	2,516			
14:00	615	420	88	28	37	25	96	1	0	0	41	5	1,356			
15:00	925	485	80	13	35	44	102	2	0	0	39	3	1,728			
16:00	510	275	97	9	27	49	88	0	0	0	33	2	1,090			
17:00	575	345	102	9	23	32	64	0	3	2	42	5	1,202			
18:00	730	460	106	54	68	55	111	25	3	1	56	35	1,704			
19:00	690	320	111	27	31	19	26	6	1	0	22	0	1,253			
20:00	485	250	91	17	22	18	53	3	0	1	32	7	979			
21:00	559	150	87	40	58	46	66	32	0	0	21	5	1,064			
Total	11,615	6,938	1,646	434	787	697	1,402	165	61	23	646	131	24,545			
%	47.3	28.3	6.7	1.8	3.2	2.8	5.7	0.7	0.2	0.1	2.6	0.5	100			

Site : Abo Bakr El-Sedeeq St.							Code: NW03									
Dir 2: Tagneed Sq.							Date: 24/5/2005									
Start Hour	Number of Vehicles												Total			
	Car		Taxi		Bus				Truck					Motorcycle		Other
					Shared Taxi	Mini	Public	Private	Pickup	2-Axle	3-Axle	> 3 Axle				
06:00	127	43	82	2	45	31	22	2	0	8	20	0	382			
7:00	690	277	120	0	33	77	50	3	1	4	7	1	1,263			
8:00	997	455	110	0	35	36	63	1	0	1	8	1	1,707			
9:00	817	507	87	9	35	17	65	1	0	0	12	9	1,559			
10:00	536	340	72	6	35	19	81	1	0	1	28	7	1,126			
11:00	485	260	47	5	36	19	100	2	0	0	36	10	1,000			
12:00	620	345	69	11	40	48	117	12	2	0	62	7	1,333			
13:00	515	290	34	8	22	29	93	13	0	0	61	2	1,067			
14:00	1,005	480	53	0	42	36	103	1	1	0	63	2	1,786			
15:00	992	532	53	14	23	49	100	2	0	0	48	2	1,815			
16:00	873	401	57	8	36	42	87	13	2	1	80	6	1,606			
17:00	1,184	566	104	8	34	59	119	12	0	0	89	21	2,196			
18:00	1,354	783	62	2	28	23	96	30	0	0	73	7	2,458			
19:00	1,338	899	63	23	15	11	21	0	0	0	33	6	2,409			
20:00	1,286	594	47	3	23	11	82	7	0	0	56	7	2,116			
21:00	797	177	32	6	14	13	38	2	0	0	17	0	1,096			
Total	13,616	6,949	1,092	105	496	520	1,237	102	6	15	693	88	24,919			
%	54.6	27.9	4.4	0.4	2.0	2.1	5.0	0.4	0.0	0.1	2.8	0.4	100			

Appendix 3.4-21: Manual Classified Traffic Count Data at Kablat St.

Site : Kablat St.							Code: NW04						
Dir 1: Mataria Sq.							Date: 30/5/2005						
Start Hour	Number of Vehicles												Total
	Car	Taxi	Bus				Truck				Motorcycle	Other	
			Shared Taxi	Mini	Public	Private	Pickup	2-Axle	3-Axle	> 3 Axle			
06:00	45	91	68	3	47	102	13	28	0	1	3	2	403
7:00	216	230	120	0	33	100	38	7	0	1	1	4	750
8:00	238	234	143	0	27	35	45	15	0	3	2	10	752
9:00	204	191	124	0	25	22	51	31	6	2	32	7	695
10:00	179	162	97	0	40	23	72	30	11	0	28	7	649
11:00	313	260	209	1	25	12	71	37	6	0	32	14	980
12:00	195	253	57	1	24	9	99	24	1	2	30	17	712
13:00	151	201	64	1	16	20	52	17	4	1	20	12	559
14:00	213	225	89	3	20	37	137	25	0	1	38	5	793
15:00	246	239	85	0	19	65	130	29	0	2	47	8	870
16:00	278	212	100	1	24	69	97	28	0	2	53	6	870
17:00	220	209	109	0	21	73	113	33	0	1	49	4	832
18:00	192	252	91	0	23	36	96	20	0	0	40	3	753
19:00	232	317	81	0	18	21	83	25	0	1	46	2	826
20:00	205	377	107	1	20	22	76	24	0	0	34	4	870
21:00	267	340	108	0	26	18	78	19	0	1	36	7	900
Total	3,394	3,793	1,652	11	408	664	1,251	392	28	18	491	112	12,214
%	27.8	31.1	13.5	0.1	3.3	5.4	10.2	3.2	0.2	0.1	4.0	0.9	100

Site : Kablat St.							Code: NW04						
Dir 2: Ismailia Canal							Date: 30/5/2005						
Start Hour	Number of Vehicles												Total
	Car	Taxi	Bus				Truck				Motorcycle	Other	
			Shared Taxi	Mini	Public	Private	Pickup	2-Axle	3-Axle	> 3 Axle			
06:00	51	54	45	0	15	83	10	4	1	1	6	4	274
7:00	179	137	151	1	32	71	43	4	1	0	8	6	633
8:00	263	155	146	1	22	10	23	13	1	0	1	20	655
9:00	275	178	106	0	24	13	43	20	2	5	13	10	689
10:00	218	172	77	0	23	7	46	18	0	0	2	7	570
11:00	224	183	77	0	21	21	78	20	3	4	14	8	653
12:00	188	162	82	1	14	18	62	21	10	1	18	6	583
13:00	158	105	80	0	23	43	67	27	10	2	30	21	566
14:00	219	214	72	0	23	32	88	23	0	1	26	4	702
15:00	245	193	74	2	15	68	106	25	0	3	38	13	782
16:00	208	175	57	0	22	71	93	21	0	1	39	8	695
17:00	277	221	84	0	14	61	84	27	0	1	48	11	828
18:00	197	208	61	0	17	55	97	18	0	2	36	8	699
19:00	207	180	53	0	23	31	80	20	0	2	39	9	644
20:00	231	238	67	0	17	18	58	30	0	1	38	3	701
21:00	234	209	68	0	13	14	75	19	0	0	41	4	677
Total	3,374	2,784	1,300	5	318	616	1,053	310	28	24	397	142	10,351
%	32.6	26.9	12.6	0.0	3.1	6.0	10.2	3.0	0.3	0.2	3.8	1.4	100

Appendix 3.4-22: Manual Classified Traffic Count Data at Lotfy El-Sayed St.

Site : Lotfy El-Sayed St.		Code: NW05											
Dir 1: Ramsis Sq.		Date: 30/5/2005											
Start Hour	Number of Vehicles											Total	
	Car	Taxi	Bus				Truck				Motorcycle		Other
			Shared Taxi	Mini	Public	Private	Pickup	2-Axle	3-Axle	> 3 Axle			
06:00	600	187	366	43	65	161	35	18	1	0	11	3	1,490
7:00	1,870	381	464	60	59	282	70	16	1	0	16	16	3,235
8:00	1,960	596	613	53	62	153	92	18	0	0	35	7	3,589
9:00	1,960	786	621	63	62	192	120	26	4	0	37	11	3,882
10:00	2,100	668	685	62	71	197	189	38	3	1	59	5	4,078
11:00	1,900	542	499	50	61	163	208	40	0	0	74	9	3,546
12:00	2,120	445	392	53	52	131	232	39	1	1	76	12	3,554
13:00	1,680	520	500	51	40	162	173	32	3	0	69	13	3,243
14:00	1,230	537	493	49	51	202	189	31	0	0	101	12	2,895
15:00	1,740	373	264	53	43	297	166	42	0	1	48	21	3,048
16:00	1,370	276	282	59	46	253	188	32	0	0	46	16	2,568
17:00	1,640	300	321	63	30	202	178	24	0	0	60	16	2,834
18:00	1,760	458	475	52	39	178	238	32	0	0	47	18	3,297
19:00	1,900	756	385	65	53	150	207	35	0	0	66	13	3,630
20:00	1,660	535	443	53	40	122	110	25	0	0	41	5	3,034
21:00	1,580	456	1,190	50	41	113	103	29	0	0	38	10	3,610
Total	27,070	7,816	7,993	879	815	2,958	2,498	477	13	3	824	187	51,533
%	52.5	15.2	15.5	1.7	1.6	5.7	4.8	0.9	0.0	0.0	1.6	0.4	100

** Note: Direction of traffic is only one way

Appendix 3.4-23: Manual Classified Traffic Count Data at Autostrade

Site : Autostrade							Code: NW06									
Dir 1: Cairo Airport							Date: 24/5/2005									
Start Hour	Number of Vehicles												Total			
	Car		Taxi		Bus				Truck					Motorcycle		Other
					Shared Taxi	Mini	Public	Private	Pickup	2-Axle	3-Axle	> 3 Axle				
06:00	212	53	78	9	13	55	29	42	9	25	8	8	541			
7:00	826	95	171	27	18	103	88	67	2	2	13	13	1,425			
8:00	1,327	335	187	26	26	62	154	39	2	0	28	21	2,207			
9:00	1,188	264	204	28	17	17	154	90	0	0	18	7	1,987			
10:00	849	216	181	8	16	7	195	121	2	3	22	3	1,623			
11:00	1,172	376	133	12	8	16	198	34	5	4	18	2	1,978			
12:00	1,249	596	109	4	13	20	250	8	2	2	20	6	2,279			
13:00	1,345	587	71	4	21	25	241	8	0	2	46	3	2,353			
14:00	1,249	249	111	15	15	50	165	83	3	3	25	15	1,983			
15:00	1,413	265	101	17	14	89	187	90	8	6	41	23	2,254			
16:00	1,450	351	113	20	12	100	156	82	10	3	40	17	2,354			
17:00	1,360	290	117	8	12	51	122	62	9	2	43	10	2,086			
18:00	1,140	238	88	20	9	22	182	47	3	1	35	11	1,796			
19:00	1,061	296	97	10	11	10	144	82	3	0	30	7	1,751			
20:00	1,304	295	77	11	7	14	98	47	3	3	32	7	1,898			
21:00	1,237	200	66	8	10	5	86	44	6	5	34	9	1,710			
Total	18,382	4,706	1,904	227	222	646	2,449	946	67	61	453	162	30,225			
%	60.8	15.6	6.3	0.8	0.7	2.1	8.1	3.1	0.2	0.2	1.5	0.5	100			

Site : Autostrade							Code: NW06									
Dir 2: Hewan							Date: 24/5/2005									
Start Hour	Number of Vehicles												Total			
	Car		Taxi		Bus				Truck					Motorcycle		Other
					Shared Taxi	Mini	Public	Private	Pickup	2-Axle	3-Axle	> 3 Axle				
06:00	233	52	145	1	9	103	112	39	3	5	7	4	713			
7:00	580	212	535	9	14	148	163	63	10	3	10	13	1,760			
8:00	1,253	235	438	9	16	57	252	65	8	7	20	1	2,361			
9:00	1,810	295	296	2	9	45	288	15	3	11	22	6	2,802			
10:00	982	259	200	4	5	20	157	15	3	2	19	3	1,669			
11:00	863	194	320	20	13	18	270	96	5	6	18	8	1,831			
12:00	877	220	359	32	24	25	200	175	6	0	31	7	1,956			
13:00	972	259	355	15	38	19	256	257	0	10	37	10	2,228			
14:00	1,053	378	234	22	22	10	258	197	4	2	19	5	2,204			
15:00	1,842	421	230	22	25	58	313	131	4	1	40	35	3,122			
16:00	1,175	319	229	15	22	71	344	125	4	7	66	17	2,394			
17:00	1,315	365	253	23	7	55	291	105	5	2	46	14	2,481			
18:00	1,165	314	260	7	12	36	302	96	5	5	45	8	2,255			
19:00	1,101	424	202	9	12	18	226	116	5	5	47	3	2,168			
20:00	930	276	217	15	11	12	205	80	7	0	33	3	1,789			
21:00	1,036	272	204	20	14	10	165	61	7	0	34	4	1,827			
Total	17,187	4,495	4,477	225	253	705	3,802	1,636	79	66	494	141	33,560			
%	51.2	13.4	13.3	0.7	0.8	2.1	11.3	4.9	0.2	0.2	1.5	0.4	100			

Appendix 3.4-24: Manual Classified Traffic Count Data at Ahmed Helmy St.

Site : Ahmed Helmy St.							Code: NW07									
Dir 1: Qalyob							Date: 30/5/2005									
Start Hour	Number of Vehicles												Total			
	Car		Taxi		Bus				Truck					Motorcycle		Other
					Shared Taxi	Mini	Public	Private	Pickup	2-Axle	3-Axle	> 3 Axle				
06:00	35	49	177	22	17	22	14	3	1	2	1	4	347			
7:00	71	80	322	36	21	29	19	5	0	0	3	10	596			
8:00	95	103	347	15	22	23	27	12	1	1	4	10	660			
9:00	103	151	384	2	16	36	40	15	0	0	9	4	760			
10:00	144	217	423	6	21	24	34	18	1	0	20	6	914			
11:00	201	257	491	2	23	19	51	23	10	1	23	6	1,107			
12:00	292	286	370	10	23	23	86	11	1	2	22	10	1,136			
13:00	404	490	539	14	25	25	94	12	1	0	17	3	1,624			
14:00	345	182	290	8	28	33	111	20	1	1	34	16	1,069			
15:00	400	183	299	18	27	77	122	31	0	0	39	26	1,222			
16:00	350	231	321	5	18	92	135	14	4	0	35	7	1,212			
17:00	327	203	283	1	15	60	98	11	2	0	35	5	1,040			
18:00	346	220	306	2	18	41	115	13	2	0	30	3	1,096			
19:00	333	227	294	2	17	31	115	11	0	0	29	2	1,061			
20:00	221	220	413	3	10	20	98	20	1	0	26	1	1,033			
21:00	194	129	295	2	14	38	108	11	1	0	25	6	823			
Total	3,861	3,228	5,554	148	315	593	1,267	230	26	7	352	119	15,700			
%	24.6	20.6	35.4	0.9	2.0	3.8	8.1	1.5	0.2	0.0	2.2	0.8	100			

Site : Ahmed Helmy St.							Code: NW07									
Dir 2: CBD							Date: 30/5/2005									
Start Hour	Number of Vehicles												Total			
	Car		Taxi		Bus				Truck					Motorcycle		Other
					Shared Taxi	Mini	Public	Private	Pickup	2-Axle	3-Axle	> 3 Axle				
06:00	126	97	214	0	17	90	20	9	1	1	12	12	599			
7:00	571	281	400	2	25	128	81	27	1	0	30	15	1,561			
8:00	1,028	467	479	3	23	32	102	17	6	0	48	18	2,223			
9:00	514	320	351	8	20	12	101	17	0	0	47	16	1,406			
10:00	509	292	306	4	26	14	68	24	1	0	22	8	1,274			
11:00	537	271	240	2	17	15	74	18	0	6	34	9	1,223			
12:00	501	263	238	4	29	12	61	17	2	0	38	8	1,173			
13:00	400	253	215	4	21	18	71	22	1	8	37	7	1,057			
14:00	433	258	243	4	16	26	99	30	0	1	47	15	1,172			
15:00	437	252	273	0	15	32	109	20	0	10	52	10	1,210			
16:00	415	305	207	0	19	25	77	14	0	0	32	23	1,117			
17:00	338	311	266	3	20	23	75	6	1	0	32	16	1,091			
18:00	199	201	235	2	14	17	84	7	2	0	34	8	803			
19:00	428	429	261	1	38	30	114	3	1	0	32	12	1,349			
20:00	509	436	215	1	13	28	98	1	0	0	40	5	1,346			
21:00	428	365	104	2	19	22	76	7	2	0	32	19	1,076			
Total	7,373	4,801	4,247	40	332	524	1,310	239	18	26	569	201	19,680			
%	37.5	24.4	21.6	0.2	1.7	2.7	6.7	1.2	0.1	0.1	2.9	1.0	100			

Appendix 3.4-25: Manual Classified Traffic Count Data at Ramsis St.

Site : Ramsis St.							Code: NW08									
Dir 1: Abbassia Sq.							Date: 30/5/2005									
Start Hour	Number of Vehicles												Total			
	Car		Taxi		Bus				Truck					Motorcycle		Other
					Shared Taxi	Mini	Public	Private	Pickup	2-Axle	3-Axle	> 3 Axle				
06:00	173	308	245	109	100	66	23	10	6	0	4	1	1,045			
7:00	528	417	294	163	152	165	36	14	5	0	26	4	1,804			
8:00	650	492	155	91	111	91	50	13	4	0	40	7	1,704			
9:00	488	472	131	139	87	38	64	24	0	0	41	4	1,488			
10:00	785	700	117	145	110	28	126	21	0	4	55	2	2,093			
11:00	638	1,010	151	122	84	25	137	27	0	1	52	4	2,251			
12:00	1,220	1,175	147	128	100	22	166	23	1	3	77	5	3,067			
13:00	908	718	217	71	84	61	108	27	0	3	86	6	2,289			
14:00	795	517	296	94	81	62	127	39	0	1	95	14	2,121			
15:00	1,077	555	244	69	83	90	145	47	3	1	82	14	2,410			
16:00	854	491	263	169	82	60	186	31	0	0	52	10	2,198			
17:00	1,164	876	308	154	119	82	141	23	0	1	38	9	2,915			
18:00	1,150	796	285	86	54	55	113	57	0	4	90	34	2,724			
19:00	1,065	729	329	119	106	80	212	accue discussio	0	10	120	37	2,807			
20:00	734	731	301	125	95	69	197	93	0	0	118	22	2,485			
21:00	715	712	190	143	78	25	146	59	0	0	88	17	2,173			
Total	12,944	10,699	3,673	1,927	1,526	1,019	1,977	508	19	28	1,064	190	35,574			
%	36.4	30.1	10.3	5.4	4.3	2.9	5.6	1.4	0.1	0.1	3.0	0.5	100			

Site : Ramsis St.							Code: NW08									
Dir 2: Ramsis Sq.							Date: 30/5/2005									
Start Hour	Number of Vehicles												Total			
	Car		Taxi		Bus				Truck					Motorcycle		Other
					Shared Taxi	Mini	Public	Private	Pickup	2-Axle	3-Axle	> 3 Axle				
06:00	183	305	276	46	101	187	23	18	0	3	25	5	1,172			
7:00	988	732	338	55	130	156	35	11	0	1	51	17	2,514			
8:00	2,050	1,310	462	76	209	175	115	89	0	0	117	65	4,668			
9:00	1,400	1,050	417	136	162	135	157	79	0	1	91	36	3,664			
10:00	793	561	296	54	118	119	103	13	4	0	48	13	2,122			
11:00	1,388	921	611	129	218	176	168	61	4	0	78	27	3,781			
12:00	1,083	818	632	160	292	333	265	63	4	17	90	9	3,766			
13:00	1,630	1,120	665	179	457	599	251	100	3	0	84	15	5,103			
14:00	565	438	232	133	107	65	156	31	0	1	58	4	1,790			
15:00	929	648	277	90	68	132	144	24	0	0	46	11	2,369			
16:00	376	323	298	41	102	127	102	23	0	0	29	2	1,423			
17:00	576	518	302	44	79	133	119	26	2	0	48	7	1,854			
18:00	563	380	368	83	207	317	119	57	10	0	80	6	2,190			
19:00	740	537	282	135	109	37	112	18	0	0	58	2	2,030			
20:00	1,250	695	206	118	67	40	60	10	0	1	23	4	2,474			
21:00	935	634	174	90	75	28	4	0	0	0	16	1	1,957			
Total	15,449	10,990	5,836	1,569	2,501	2,759	1,933	623	27	24	942	224	42,877			
%	36.0	25.6	13.6	3.7	5.8	6.4	4.5	1.5	0.1	0.1	2.2	0.5	100			

Appendix 3.4-26: Manual Classified Traffic Count Data at Salah Salem Road

Site : Salah Salem Road							Code: NW09									
Dir 1: Cairo Airport							Date: 24/5/2005									
Start Hour	Number of Vehicles												Total			
	Car		Taxi		Bus				Truck					Motorcycle		Other
					Shared Taxi	Mini	Public	Private	Pickup	2-Axle	3-Axle	> 3 Axle				
06:00	353	179	278	12	57	66	85	9	0	0	15	23	1,077			
7:00	1,020	352	586	6	116	83	147	7	5	0	61	8	2,391			
8:00	1,080	349	527	10	60	55	144	43	4	3	19	15	2,309			
9:00	1,159	269	643	7	48	10	278	113	5	0	37	9	2,578			
10:00	1,123	278	352	19	57	18	254	99	1	2	97	17	2,317			
11:00	1,345	924	417	5	52	13	392	118	3	3	121	16	3,409			
12:00	1,323	567	353	8	46	18	286	24	2	2	88	15	2,732			
13:00	1,173	292	589	15	126	30	328	13	4	1	41	19	2,631			
14:00	1,420	577	291	11	43	70	282	94	0	0	0	91	2,879			
15:00	1,640	815	327	13	20	123	383	84	0	0	76	6	3,487			
16:00	1,985	587	412	20	51	121	340	114	3	0	72	14	3,719			
17:00	1,600	635	405	8	35	127	399	191	0	0	79	4	3,483			
18:00	1,351	628	385	7	31	61	347	70	2	0	90	4	2,976			
19:00	1,585	455	382	2	30	47	336	139	3	1	79	2	3,061			
20:00	1,705	680	360	0	27	37	322	61	1	0	81	3	3,277			
21:00	1,375	630	326	0	27	44	235	37	1	0	68	3	2,746			
Total	21,237	8,217	6,633	143	826	923	4,558	1,216	34	12	1,024	249	45,072			
%	47.1	18.2	14.7	0.3	1.8	2.0	10.1	2.7	0.1	0.0	2.3	0.6	100			

Site : Salah Salem Road							Code: NW09									
Dir 2: Giza Sq.							Date: 24/5/2005									
Start Hour	Number of Vehicles												Total			
	Car		Taxi		Bus				Truck					Motorcycle		Other
					Shared Taxi	Mini	Public	Private	Pickup	2-Axle	3-Axle	> 3 Axle				
06:00	1,031	147	250	9	63	88	80	53	4	0	2	8	1,735			
7:00	1,126	323	461	3	133	221	138	80	1	1	2	1	2,490			
8:00	2,145	481	582	1	82	102	201	74	7	1	10	0	3,686			
9:00	1,666	499	787	1	93	48	238	83	7	3	59	3	3,487			
10:00	2,200	468	629	4	78	35	250	54	8	6	67	5	3,804			
11:00	1,171	653	298	11	40	33	276	91	0	2	45	6	2,626			
12:00	2,000	845	284	7	38	23	220	51	0	1	33	8	3,510			
13:00	2,055	716	244	8	73	27	193	39	0	3	30	6	3,394			
14:00	1,110	890	277	12	67	41	225	53	1	2	30	4	2,712			
15:00	1,569	872	257	33	39	63	170	63	0	2	27	46	3,141			
16:00	1,203	254	309	35	53	51	297	10	4	6	34	12	2,268			
17:00	1,232	323	375	14	31	49	250	56	0	0	64	20	2,414			
18:00	977	316	367	12	41	29	212	92	0	0	53	12	2,111			
19:00	1,450	716	368	16	41	36	271	88	0	0	60	5	3,051			
20:00	1,279	568	242	11	39	14	236	27	2	4	43	10	2,475			
21:00	1,376	418	571	11	55	21	386	107	3	1	68	6	3,023			
Total	23,590	8,489	6,301	188	966	881	3,643	1,021	37	32	627	152	45,927			
%	51.4	18.5	13.7	0.4	2.1	1.9	7.9	2.2	0.1	0.1	1.4	0.3	100			

Appendix 3.4-27: Manual Classified Traffic Count Data at Tereat El-Zomor Road

Site : Tereat El-Zomor Road							Code: NW10									
Dir 1: Haram St.							Date: 24/5/2005									
Start Hour	Number of Vehicles												Total			
	Car		Taxi		Bus				Truck					Motorcycle		Other
					Shared Taxi	Mini	Public	Private	Pickup	2-Axle	3-Axle	> 3 Axle				
06:00	118	145	146	75	5	59	44	12	3	1	60	32	700			
7:00	535	430	360	14	20	49	65	20	0	0	164	114	1,771			
8:00	775	495	350	0	15	14	71	20	0	0	113	55	1,908			
9:00	645	440	395	2	10	34	72	33	0	0	97	36	1,764			
10:00	342	393	369	0	13	69	117	49	2	0	171	28	1,553			
11:00	253	315	352	0	16	107	173	59	5	0	158	20	1,458			
12:00	334	334	425	0	9	6	73	1	1	10	66	5	1,264			
13:00	448	416	267	0	12	11	73	1	0	0	43	1	1,272			
14:00	459	383	418	2	9	32	112	15	0	0	94	10	1,534			
15:00	398	343	386	3	7	37	132	2	0	0	128	9	1,445			
16:00	309	300	362	0	8	46	106	2	1	0	78	12	1,224			
17:00	470	336	380	0	6	19	144	3	1	0	112	10	1,481			
18:00	397	334	365	0	21	9	116	15	0	0	78	10	1,345			
19:00	705	554	285	0	7	3	118	19	0	1	86	11	1,789			
20:00	893	817	280	1	24	14	126	11	0	0	70	62	2,298			
21:00	908	696	275	0	9	14	53	6	0	0	45	8	2,014			
Total	7,989	6,731	5,415	97	191	523	1,595	268	13	12	1,563	423	24,820			
%	32.2	27.1	21.8	0.4	0.8	2.1	6.4	1.1	0.1	0.0	6.3	1.7	100			

Site : Tereat El-Zomor Road							Code: NW10									
Dir 2: Ring Road							Date: 24/5/2005									
Start Hour	Number of Vehicles												Total			
	Car		Taxi		Bus				Truck					Motorcycle		Other
					Shared Taxi	Mini	Public	Private	Pickup	2-Axle	3-Axle	> 3 Axle				
06:00	52	76	46	3	13	56	48	9	5	1	46	12	367			
7:00	161	152	218	1	13	50	27	5	0	0	65	19	711			
8:00	310	167	328	0	11	10	40	3	0	0	44	14	927			
9:00	277	226	248	0	11	5	46	4	1	0	47	8	873			
10:00	250	207	288	0	11	7	87	0	0	0	30	3	883			
11:00	435	305	560	0	8	3	77	21	2	0	65	7	1,483			
12:00	376	320	354	0	0	1	57	27	0	0	67	3	1,205			
13:00	290	230	315	3	9	1	53	7	0	0	55	7	970			
14:00	407	364	503	2	4	5	29	5	1	0	58	11	1,389			
15:00	485	310	670	0	5	9	37	4	0	0	82	12	1,614			
16:00	278	267	570	1	14	35	52	21	0	0	83	19	1,340			
17:00	367	239	224	0	11	11	64	12	1	1	37	26	993			
18:00	408	298	295	0	6	13	58	13	0	0	42	24	1,157			
19:00	556	393	256	0	7	5	56	18	0	0	56	7	1,354			
20:00	443	264	322	0	10	7	66	23	0	0	63	8	1,206			
21:00	649	385	421	0	6	16	87	24	4	0	91	18	1,701			
Total	5,744	4,203	5,618	10	139	234	884	196	14	2	931	198	18,173			
%	31.6	23.1	30.9	0.1	0.8	1.3	4.9	1.1	0.1	0.0	5.1	1.1	100			

Appendix 3.4-28: Manual Classified Traffic Count Data at Sudan St.

Site : Sudan St. Dir 1: Imbaba							Code: NW11 Date: 24/5/2005									
Start Hour	Number of Vehicles												Total			
	Car		Taxi		Bus				Truck					Motorcycle		Other
					Shared Taxi	Mini	Public	Private	Pickup	2-Axle	3-Axle	> 3 Axle				
06:00	41	96	41	64	20	53	10	7	1	1	4	3	341			
7:00	120	138	101	176	20	117	13	16	1	0	10	6	718			
8:00	250	172	158	25	24	152	19	18	1	0	17	12	848			
9:00	306	315	172	9	23	147	31	25	0	0	31	10	1,069			
10:00	271	309	123	33	31	89	54	28	1	0	19	4	962			
11:00	363	294	79	138	29	64	59	31	1	0	22	8	1,088			
12:00	396	263	66	147	35	60	53	27	1	0	58	5	1,111			
13:00	330	257	110	49	23	76	66	20	0	0	39	5	975			
14:00	358	234	150	3	26	147	77	32	0	0	46	11	1,084			
15:00	356	228	152	7	20	189	78	26	0	0	55	11	1,122			
16:00	525	306	145	8	21	152	57	15	1	0	44	7	1,281			
17:00	432	217	136	5	22	120	50	14	1	0	45	6	1,048			
18:00	490	307	117	3	19	110	57	11	0	31	6	3	1,154			
19:00	394	217	138	5	16	119	43	12	0	0	50	6	1,000			
20:00	448	285	115	3	18	95	41	10	0	11	27	4	1,057			
21:00	495	283	109	6	18	87	17	6	0	0	67	16	1,104			
Total	5,575	3,921	1,912	681	365	1,777	725	298	8	43	540	117	15,962			
%	34.9	24.6	12.0	4.3	2.3	11.1	4.5	1.9	0.1	0.3	3.4	0.7	100			

Site : Sudan St. Dir 2: Haram St.							Code: NW11 Date: 24/5/2005									
Start Hour	Number of Vehicles												Total			
	Car		Taxi		Bus				Truck					Motorcycle		Other
					Shared Taxi	Mini	Public	Private	Pickup	2-Axle	3-Axle	> 3 Axle				
06:00	96	124	96	31	32	182	58	13	1	0	19	5	657			
7:00	309	257	159	10	25	309	57	8	1	0	54	2	1,191			
8:00	503	368	119	6	15	174	55	9	0	1	67	2	1,319			
9:00	532	478	151	4	24	163	76	30	1	1	46	8	1,514			
10:00	385	325	136	3	24	118	67	25	0	0	49	3	1,135			
11:00	443	421	129	3	24	117	125	58	1	0	47	7	1,375			
12:00	471	389	111	4	19	100	55	19	1	0	35	1	1,205			
13:00	418	344	120	3	25	114	60	29	3	0	30	3	1,149			
14:00	480	303	111	2	20	100	102	28	1	0	53	6	1,206			
15:00	448	325	82	5	17	94	75	18	1	0	39	0	1,104			
16:00	451	319	115	41	19	93	61	35	1	0	23	10	1,168			
17:00	424	248	101	5	19	93	73	14	0	0	42	4	1,023			
18:00	516	395	128	3	24	120	75	16	2	0	34	5	1,318			
19:00	635	440	104	3	21	98	44	11	1	0	35	12	1,404			
20:00	613	443	89	2	14	80	65	13	1	0	26	2	1,348			
21:00	598	415	114	26	17	114	35	13	0	0	32	0	1,364			
Total	7,322	5,594	1,865	151	339	2,069	1,083	339	15	2	631	70	19,480			
%	37.6	28.7	9.6	0.8	1.7	10.6	5.6	1.7	0.1	0.0	3.2	0.4	100			

APPENDIX 3.5

TRAFFIC FLOW CHARTS

Appendix 3.5-1: Fluctuation and Composition of Traffic Volume at Warraq Bridge (B01)

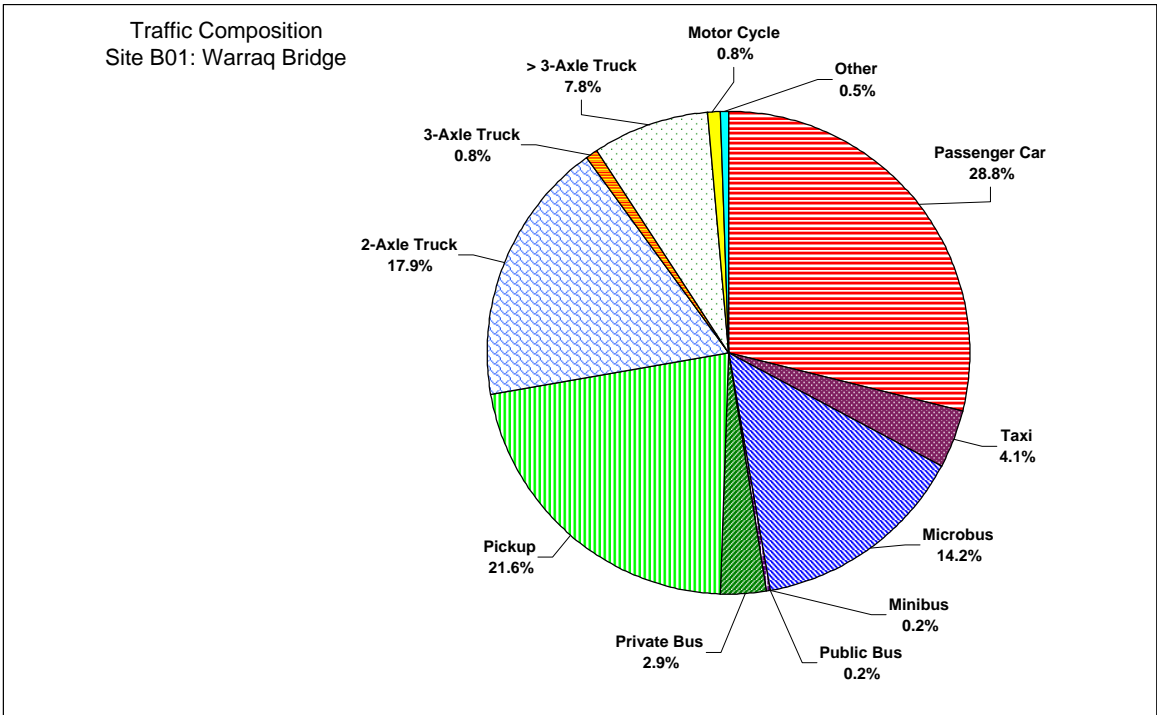
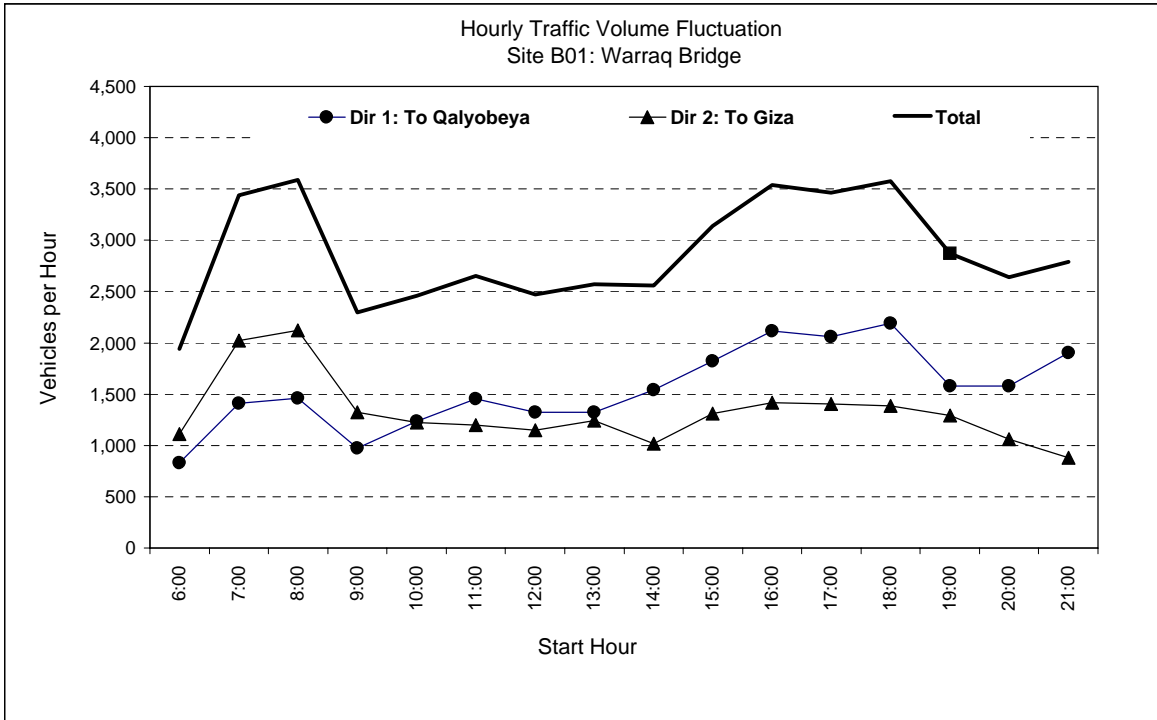

Appendix 3.5-2: Fluctuation and Composition of Traffic Volume at Rod El Farag Bridge (B02)

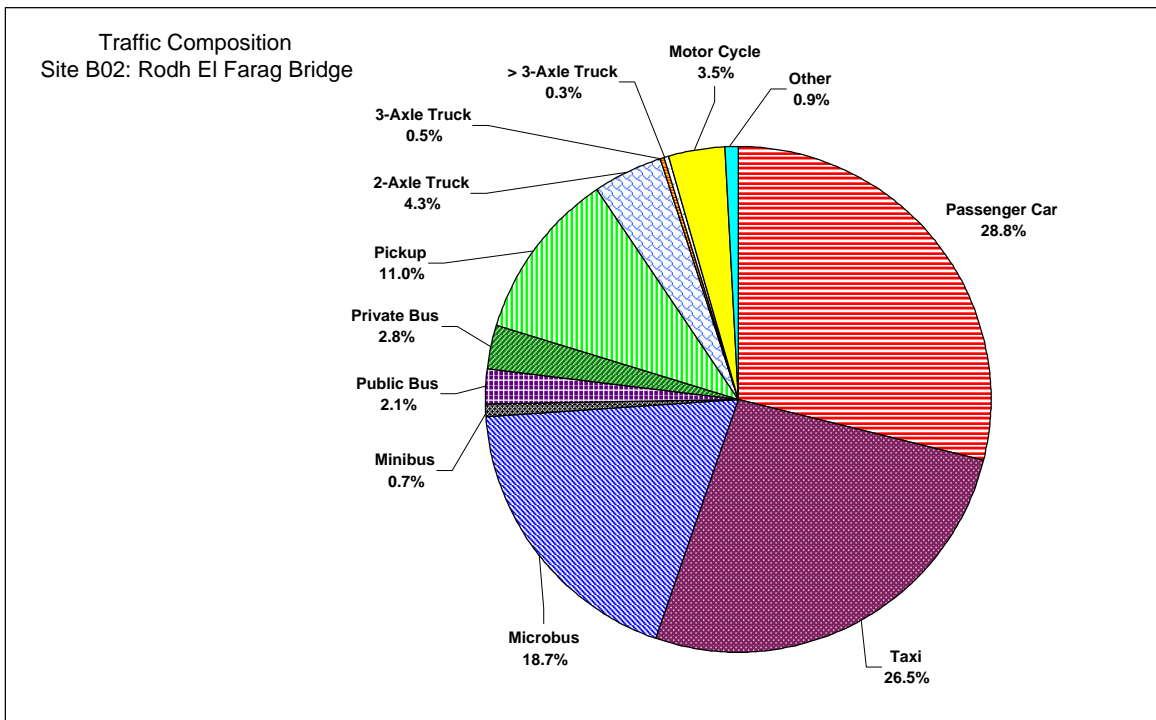
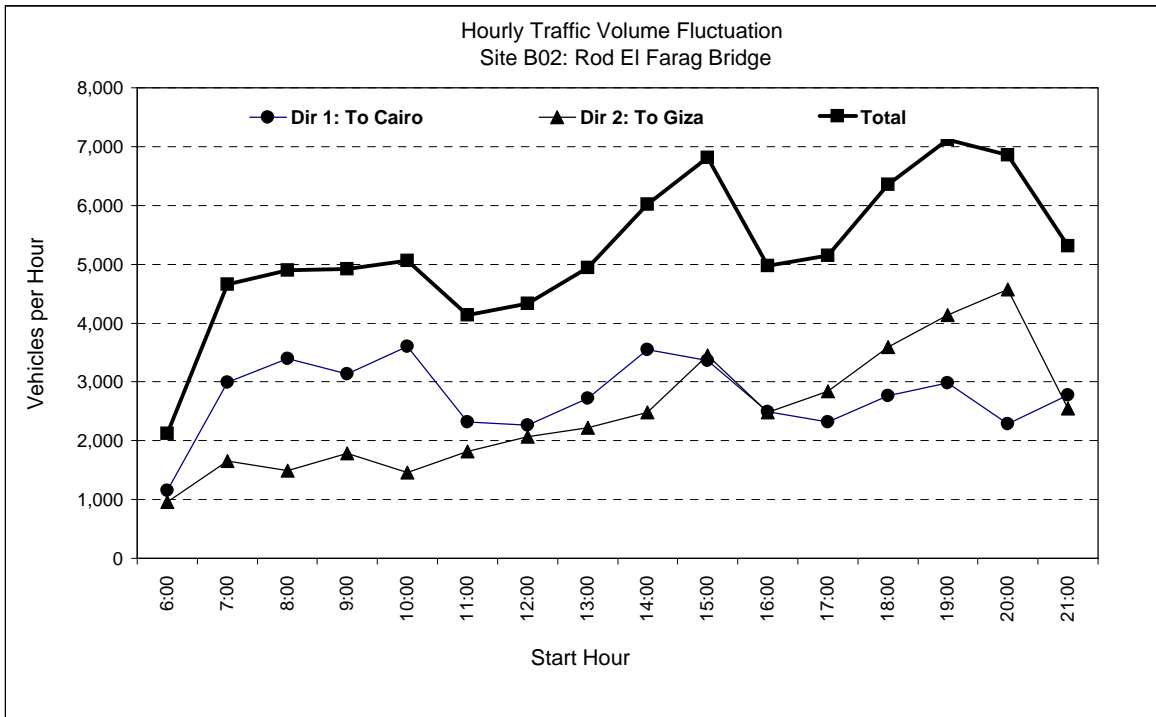

Appendix 3.5-3: Fluctuation and Composition of Traffic Volume at Imbaba Bridge (B03)

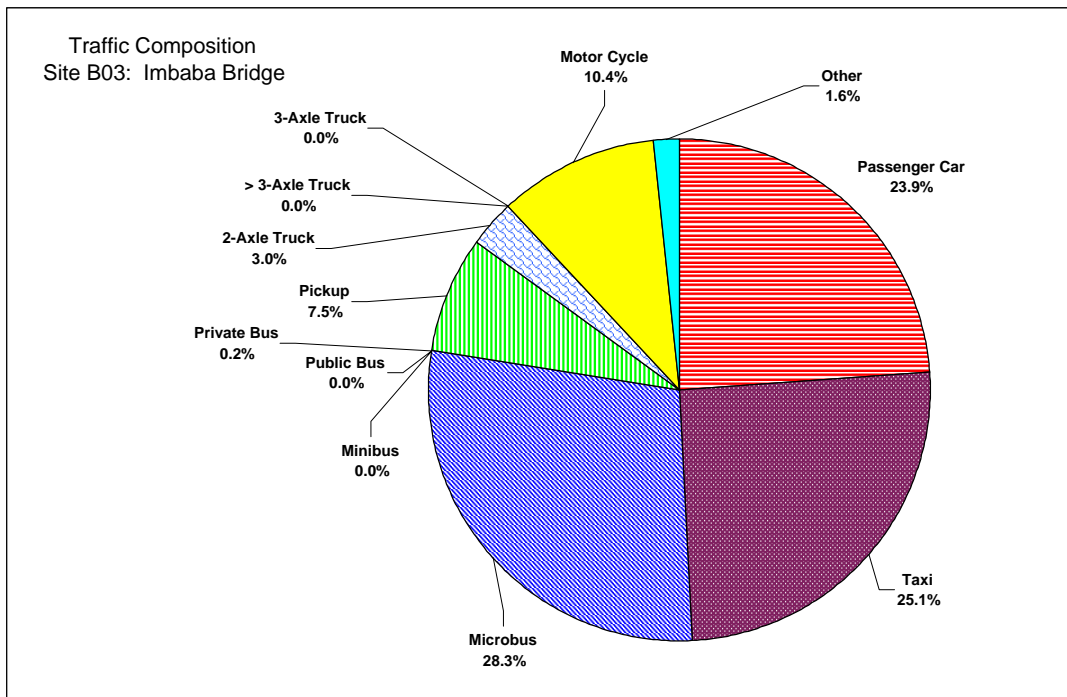
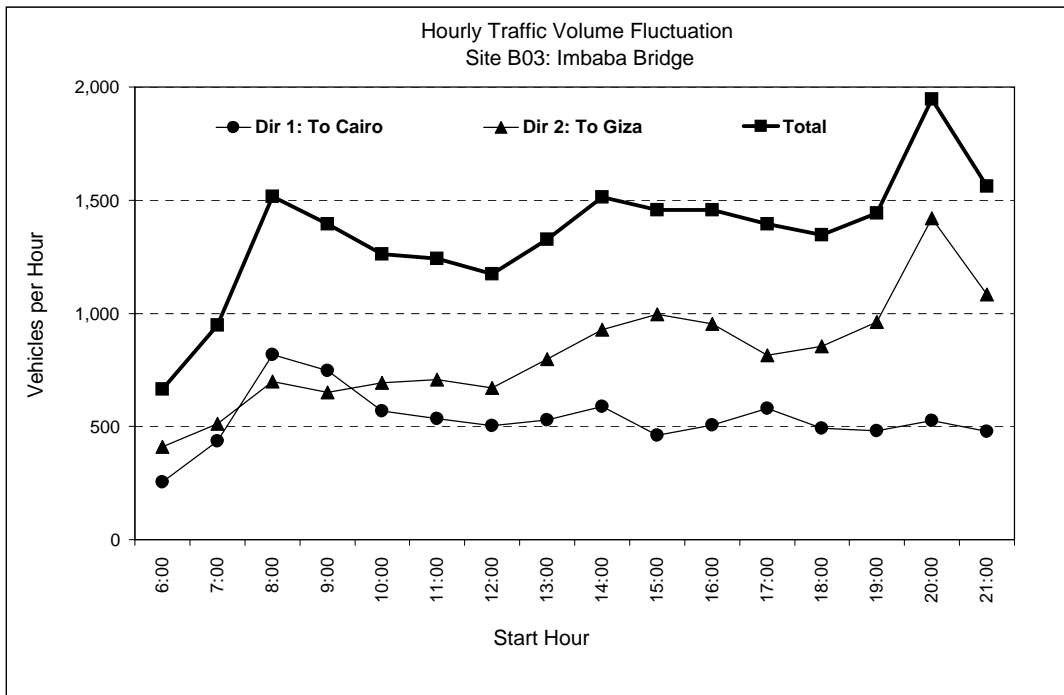

Appendix 3.5-4: Fluctuation and Composition of Traffic Volume at 15th of May Bridge (B04)

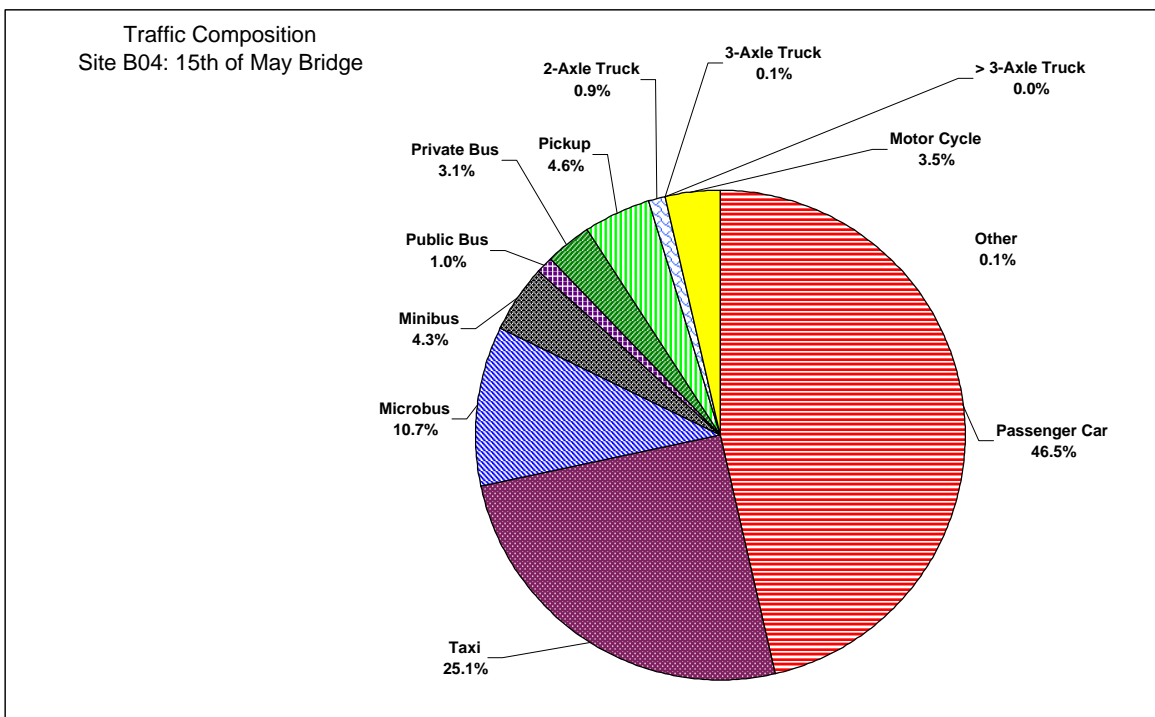
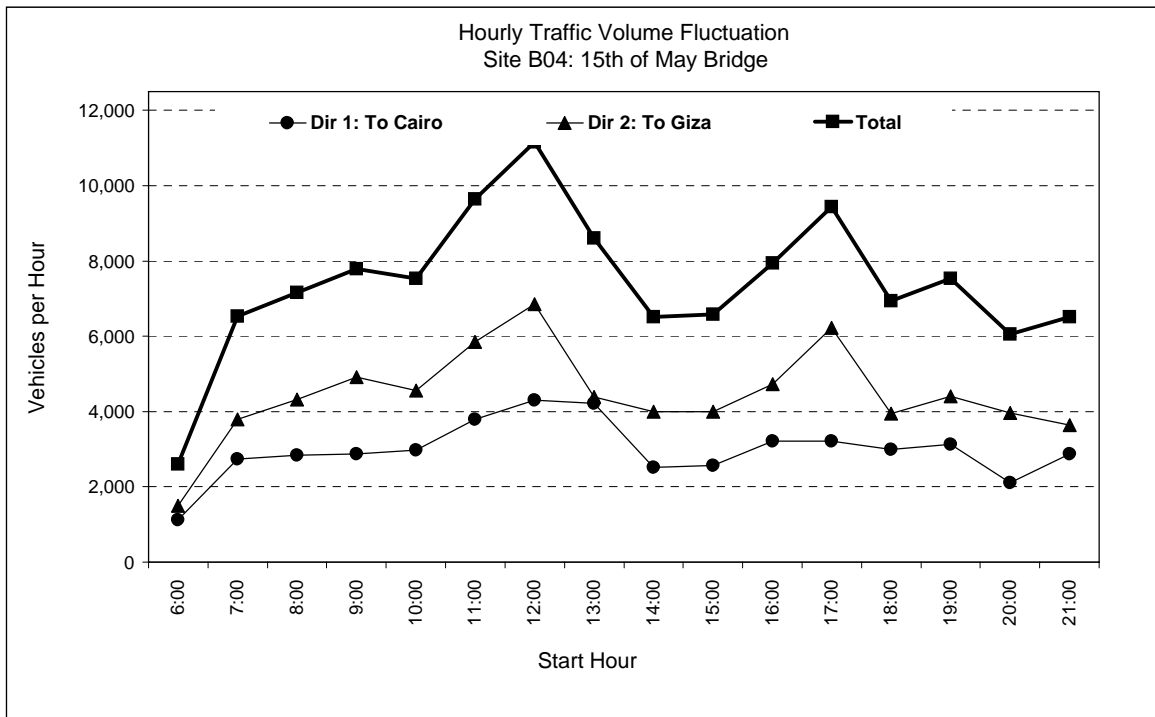

Appendix 3.5-5: Fluctuation and Composition of Traffic Volume at 6th of October Bridge (B05)

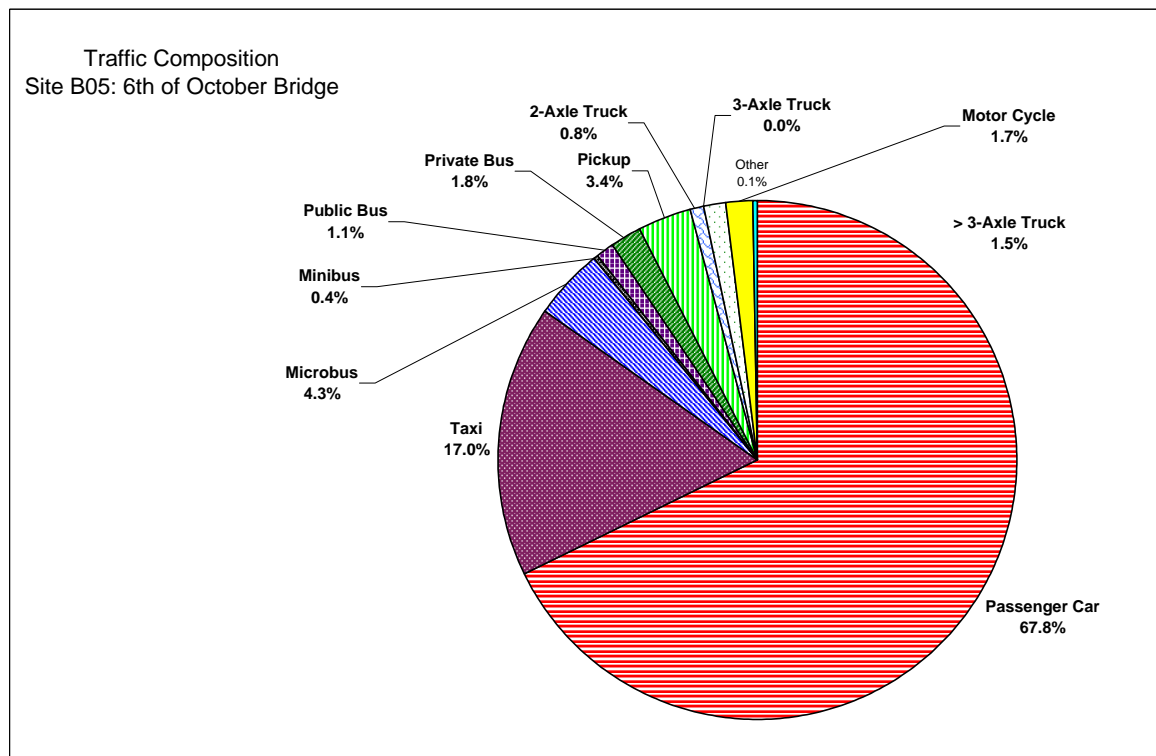
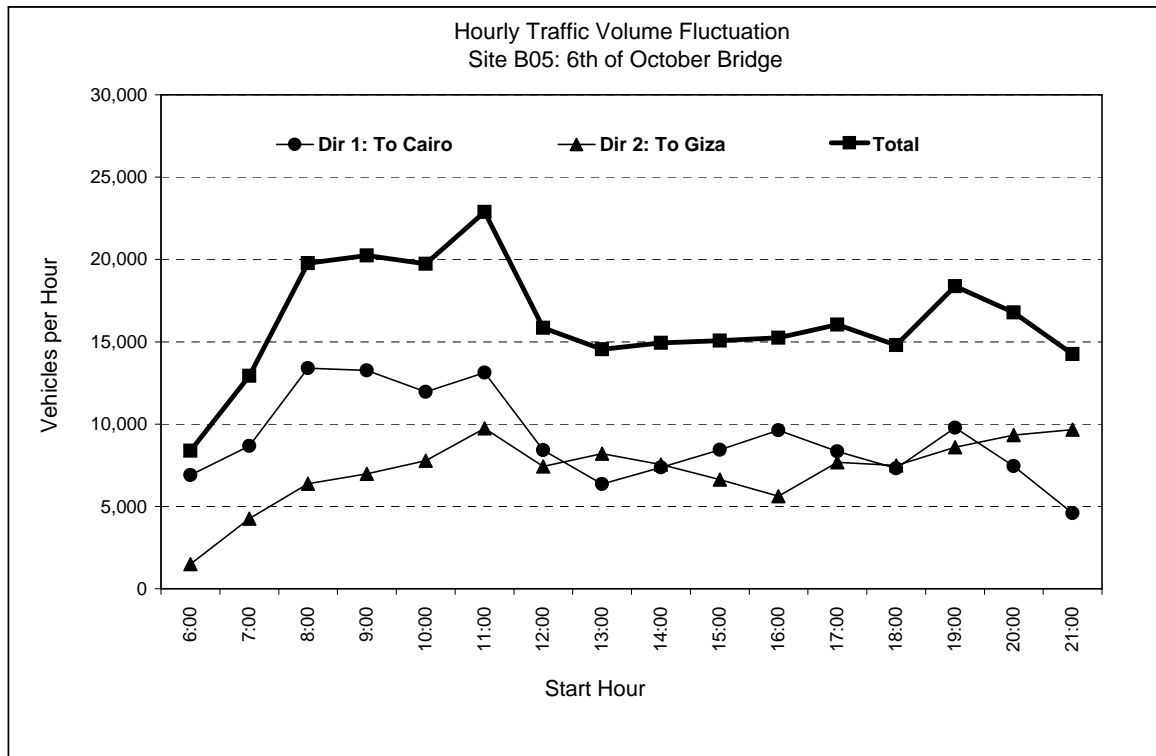

Appendix 3.5-6: Fluctuation and Composition of Traffic Volume at Galaa Bridge (B06)

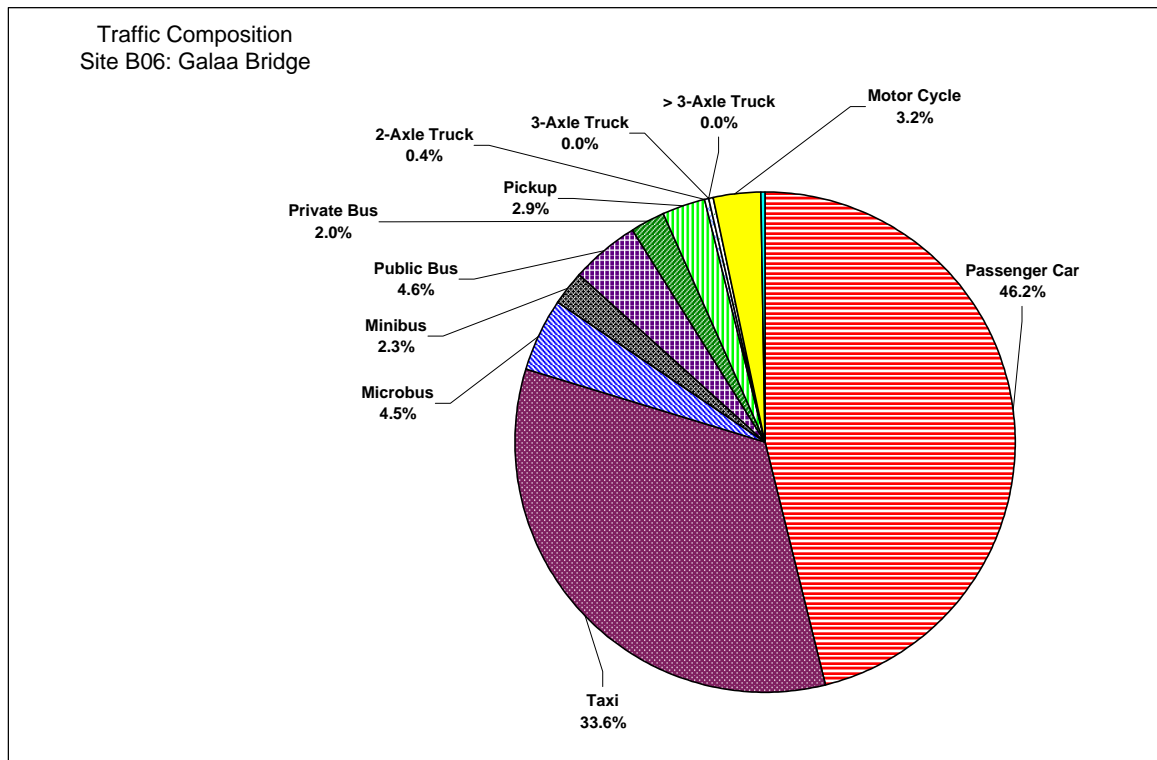
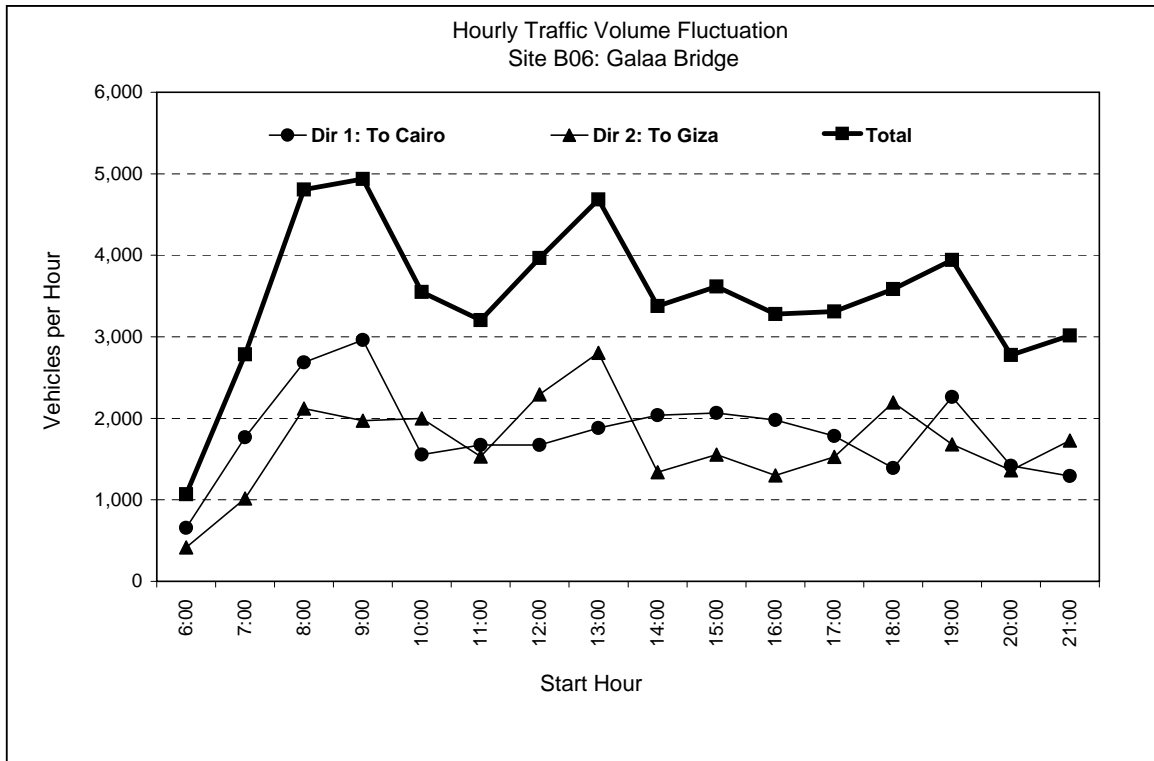

Appendix 3.5-7: Fluctuation and Composition of Traffic Volume at Gamaa Bridge (B07)

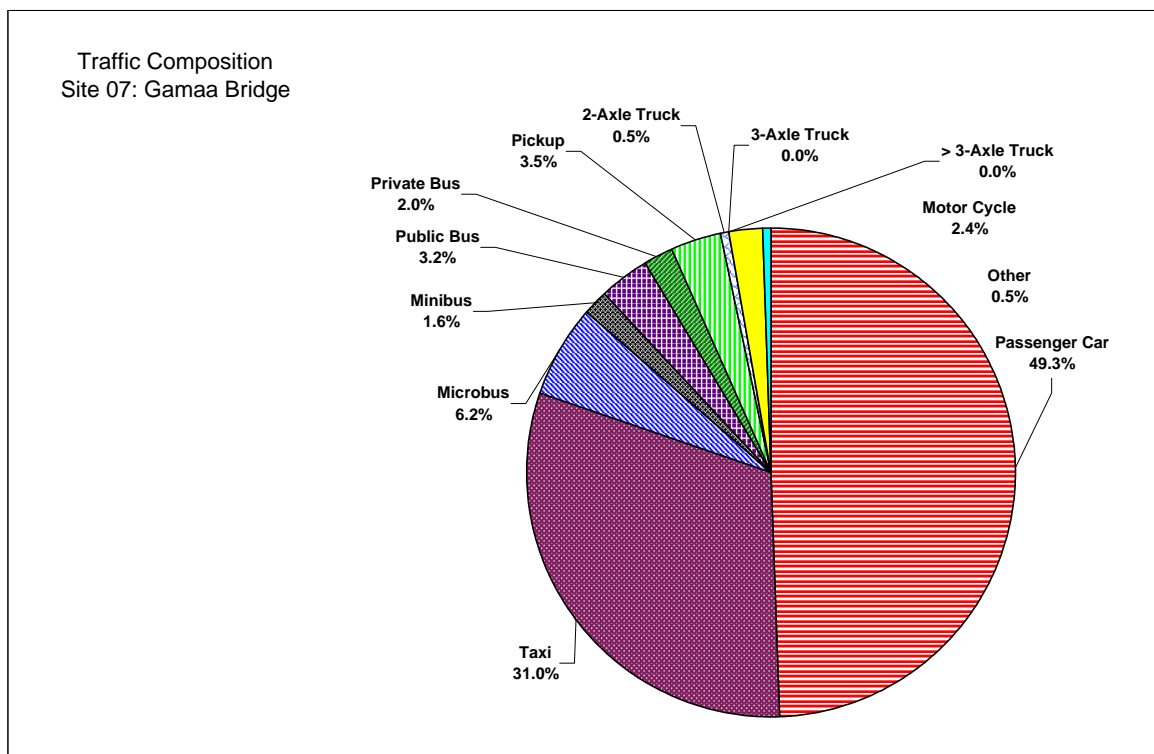
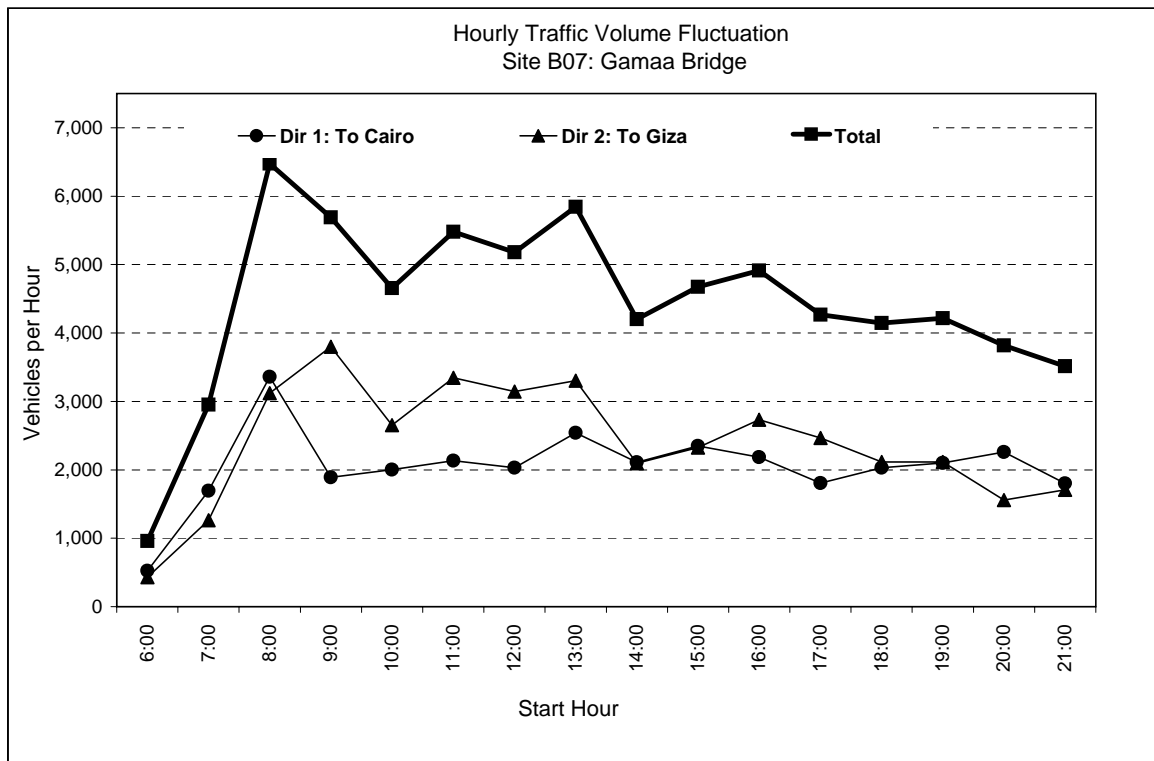

Appendix 3.5-8: Fluctuation and Composition of Traffic Volume at Giza Bridge (B08)

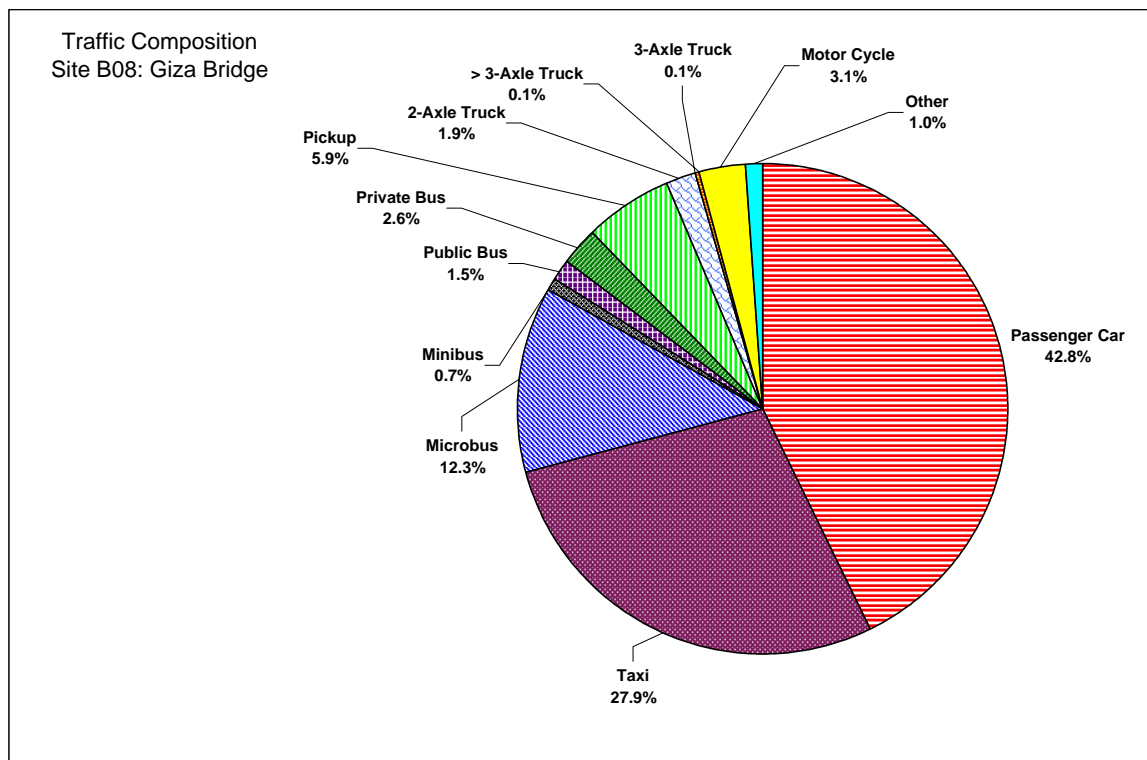
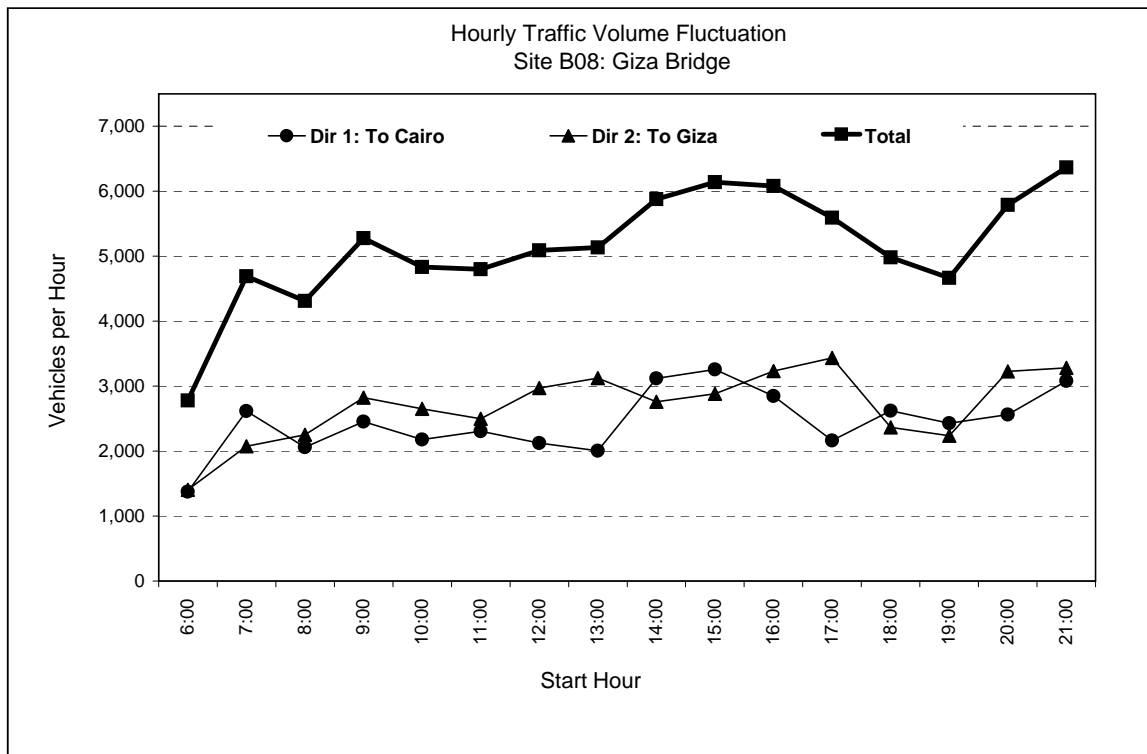

Appendix 3.5-9: Fluctuation and Composition of Traffic Volume at Moneeb Bridge (B09)

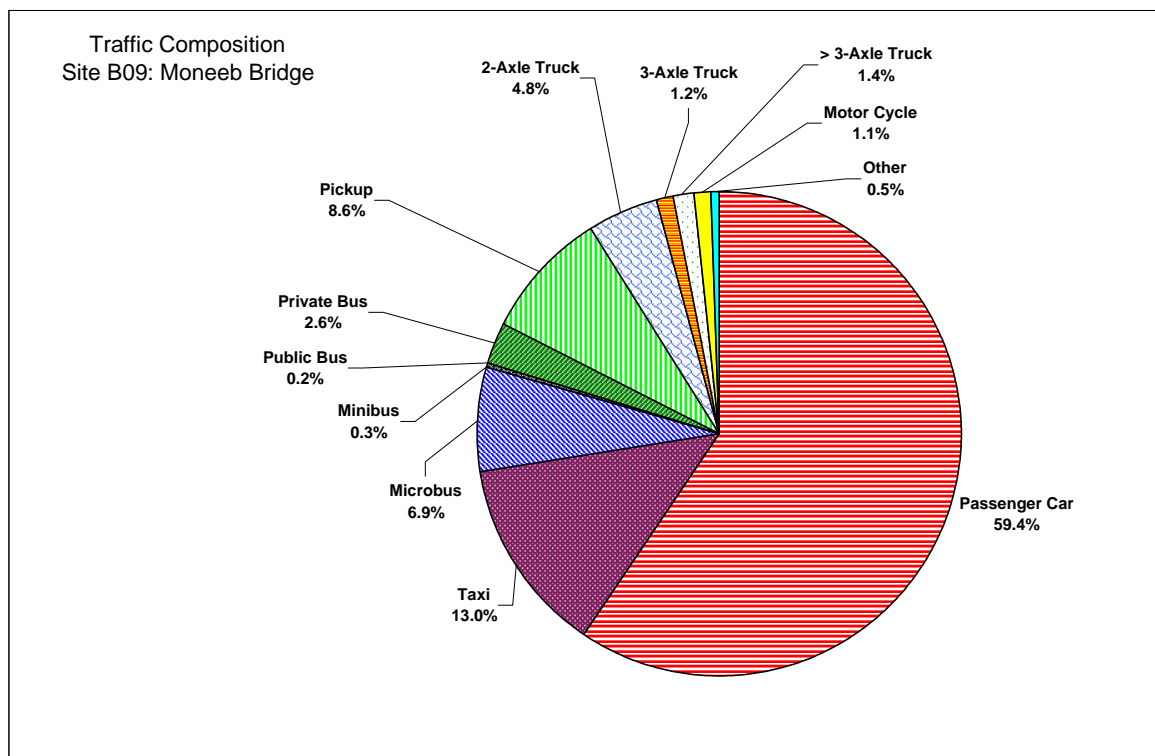
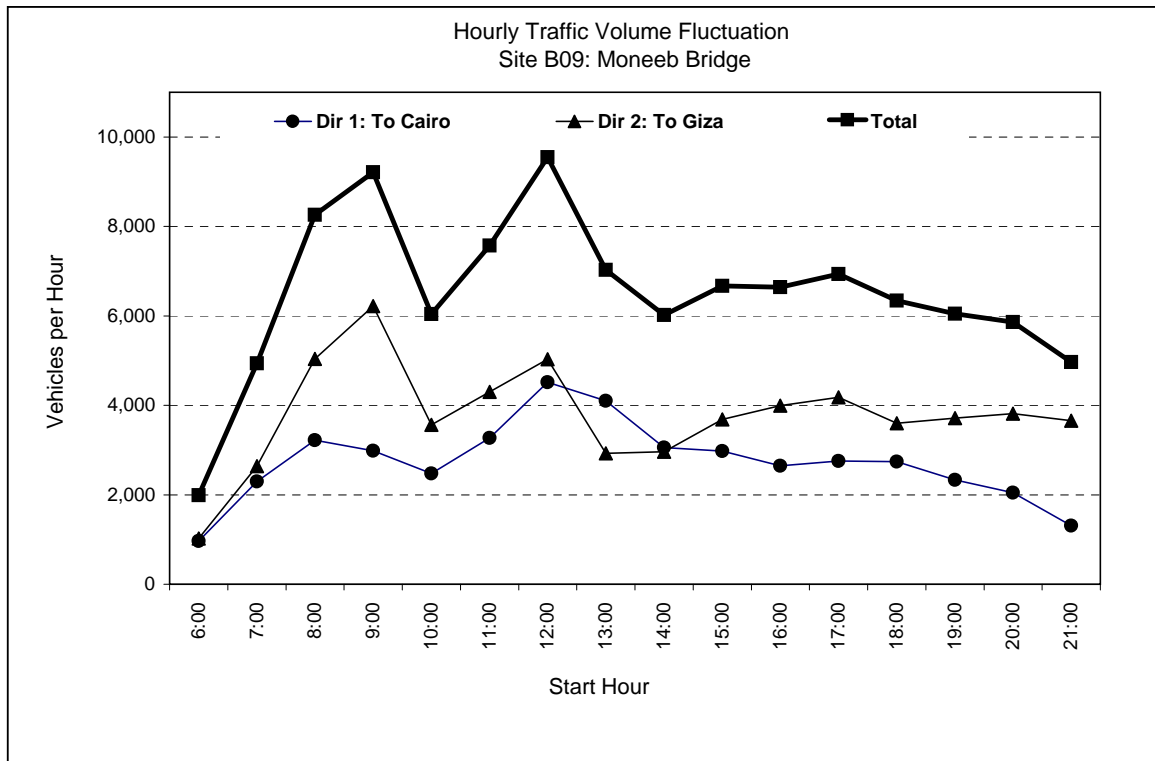

Appendix 3.5-10: Fluctuation and Composition of Traffic Volume at Marazeeq Bridge (B10)

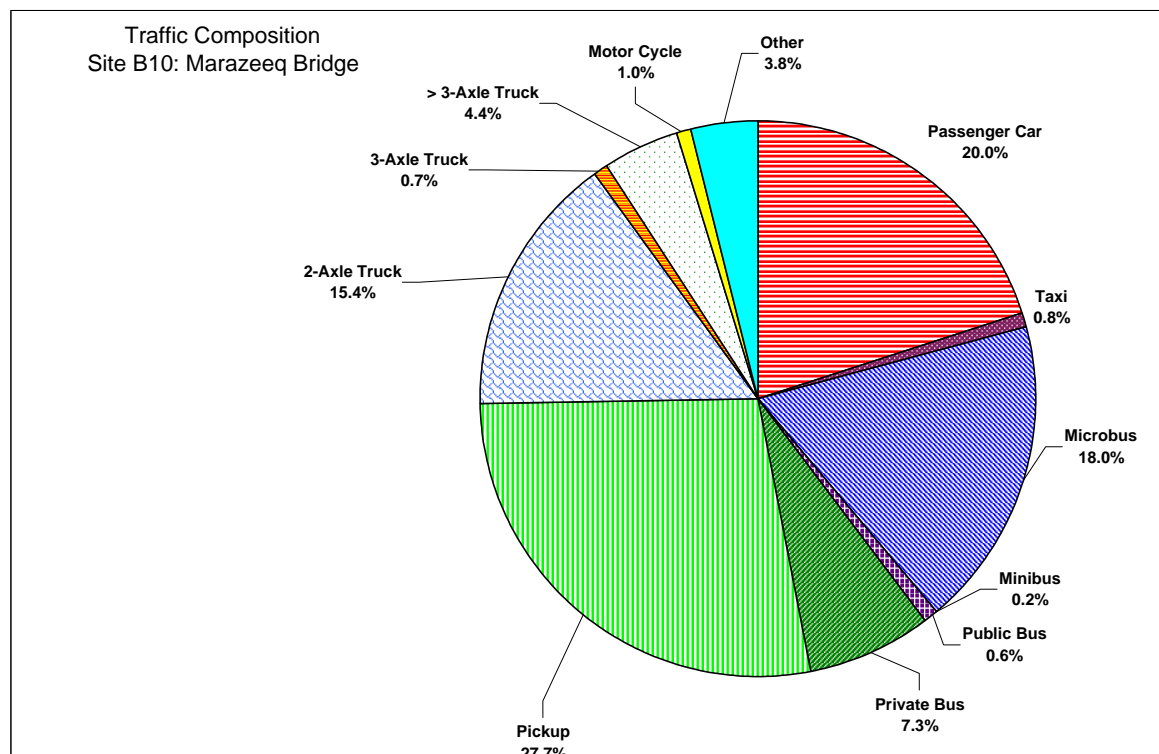
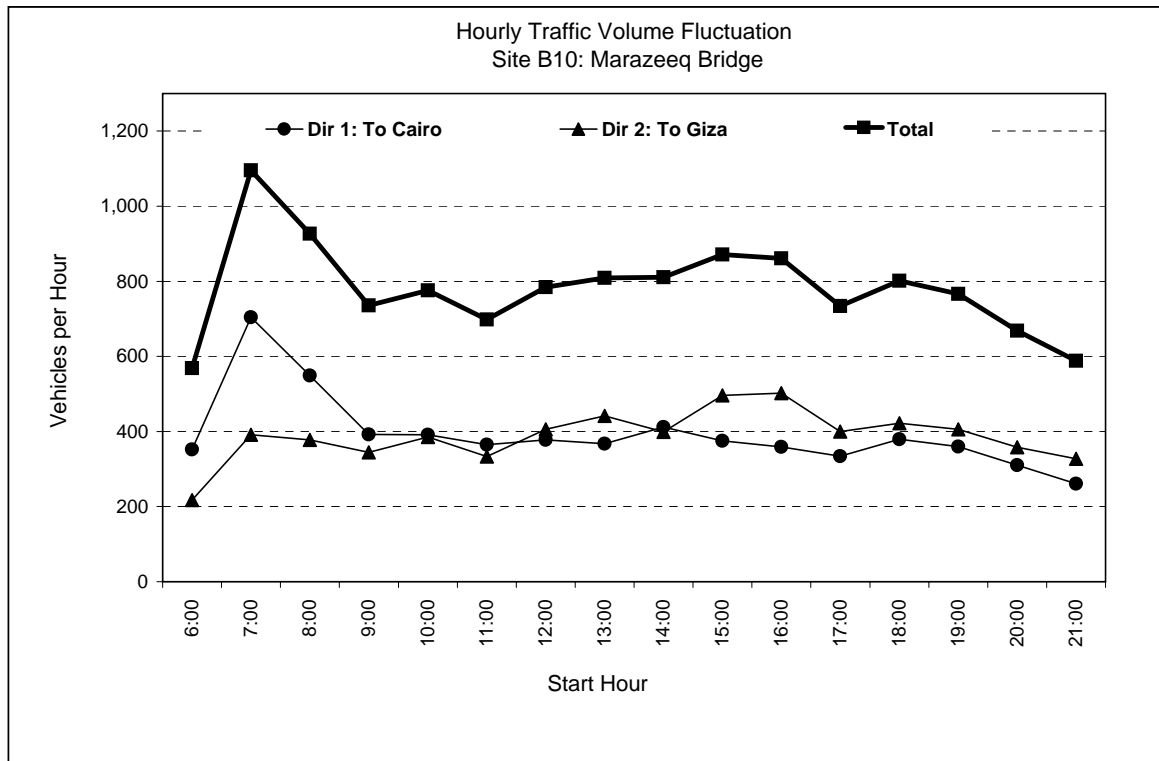

Appendix 3.5-11: Fluctuation and Composition of Traffic Volume at 26th of July Corridor (A)

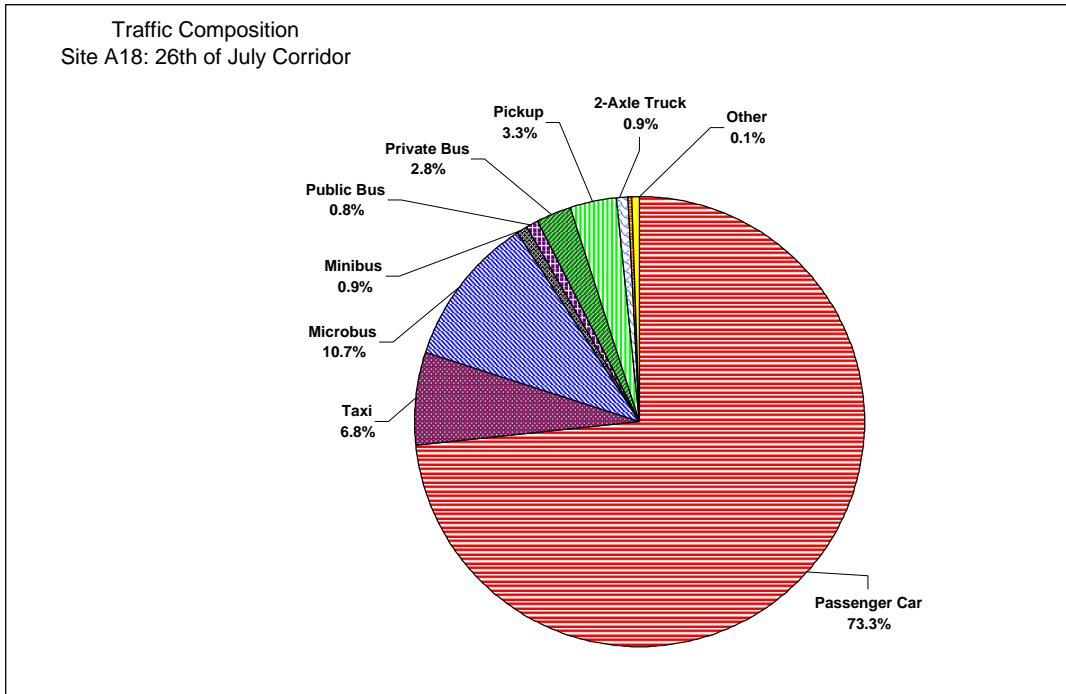
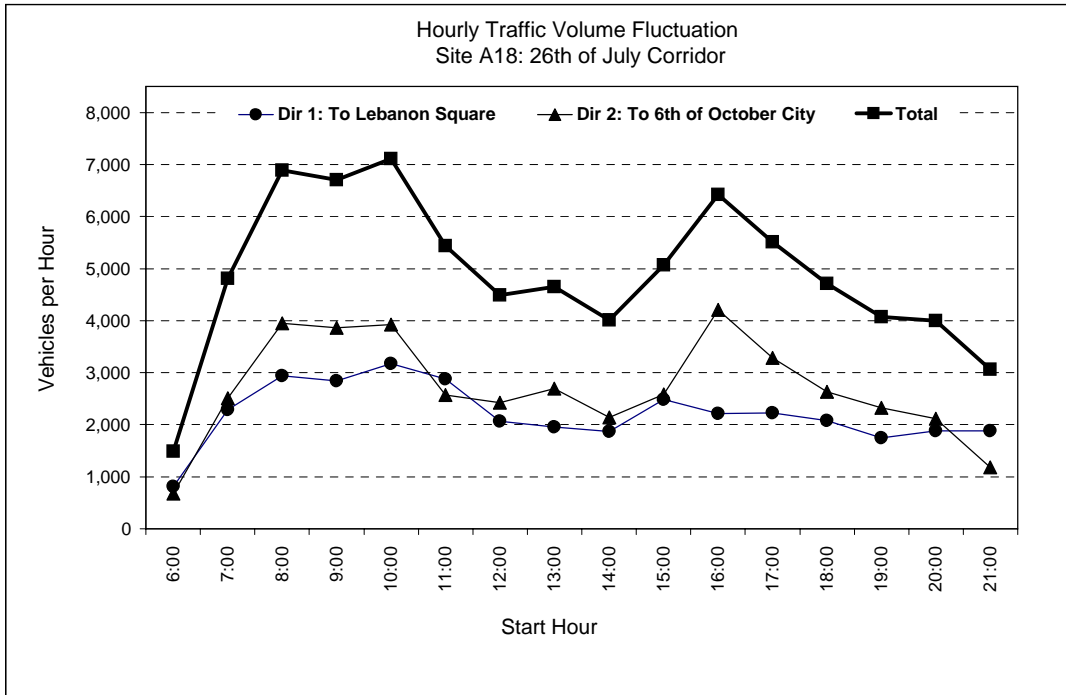

Appendix 3.5-12: Fluctuation and Composition of Traffic Volume at Suez Desert Road (A21)

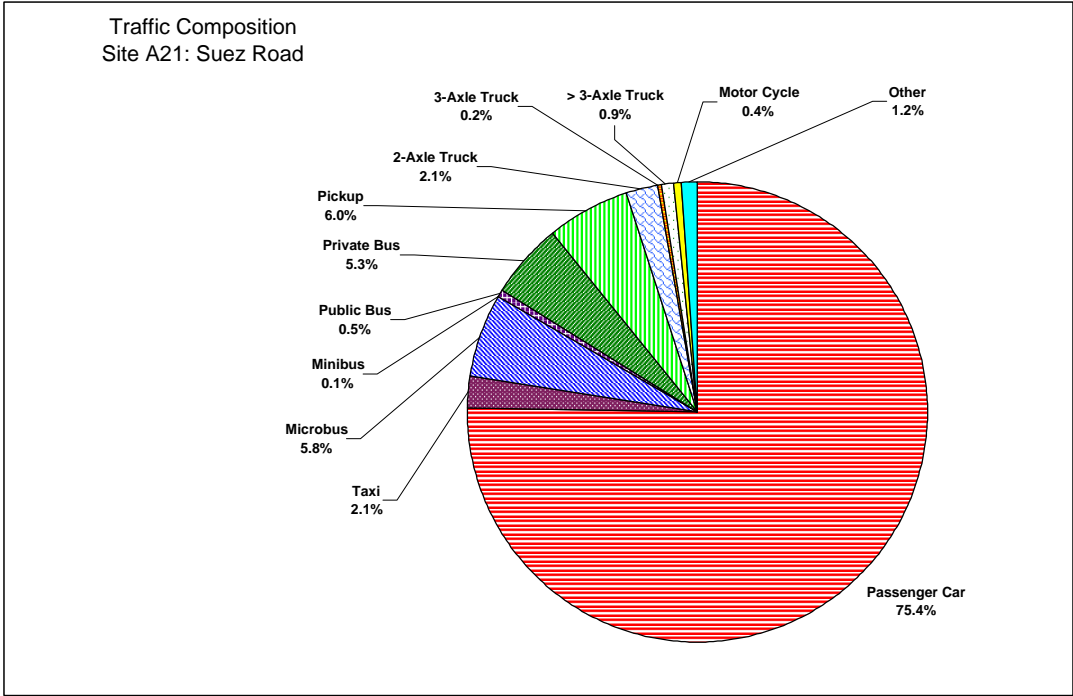
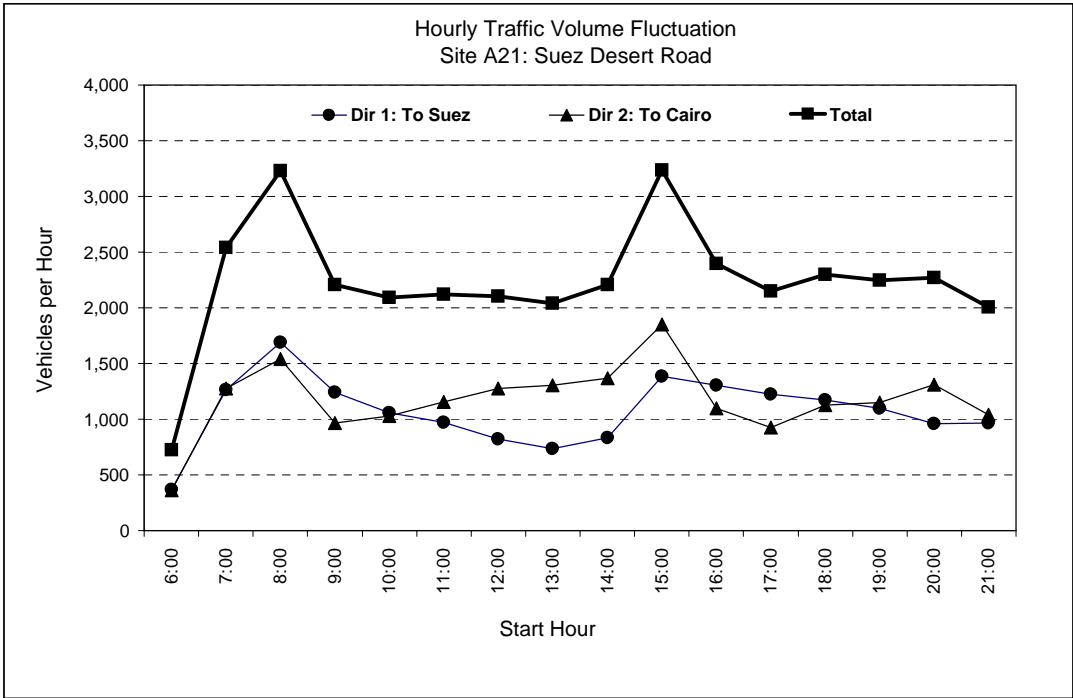

Appendix 3.5-13: Fluctuation and Composition of Traffic Volume at Alexandria Agriculture Road (A35)

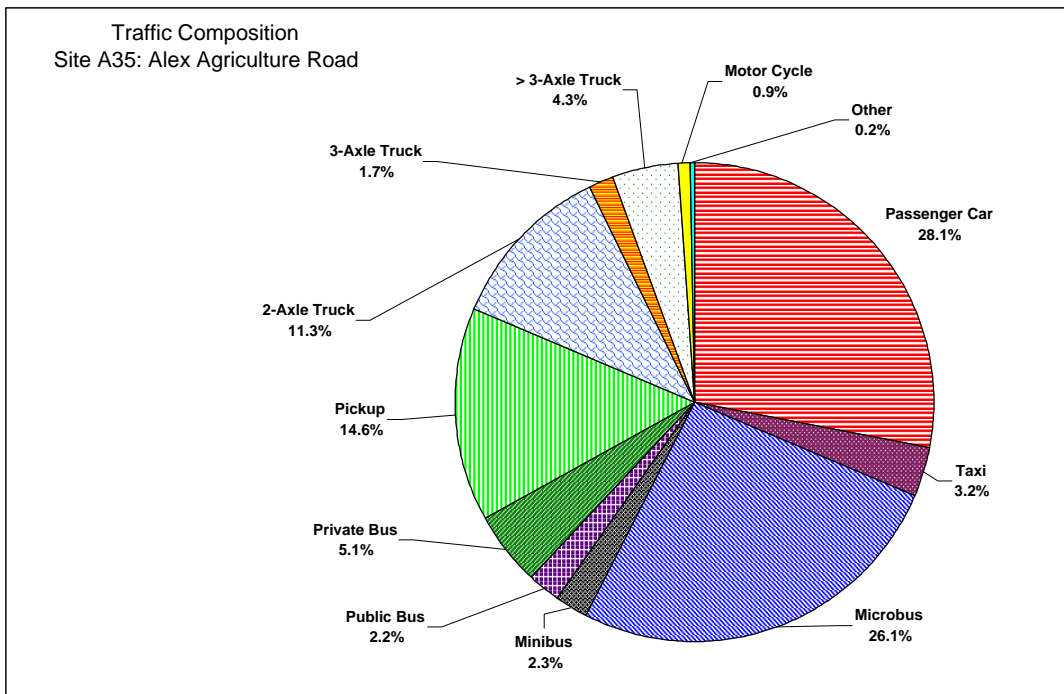
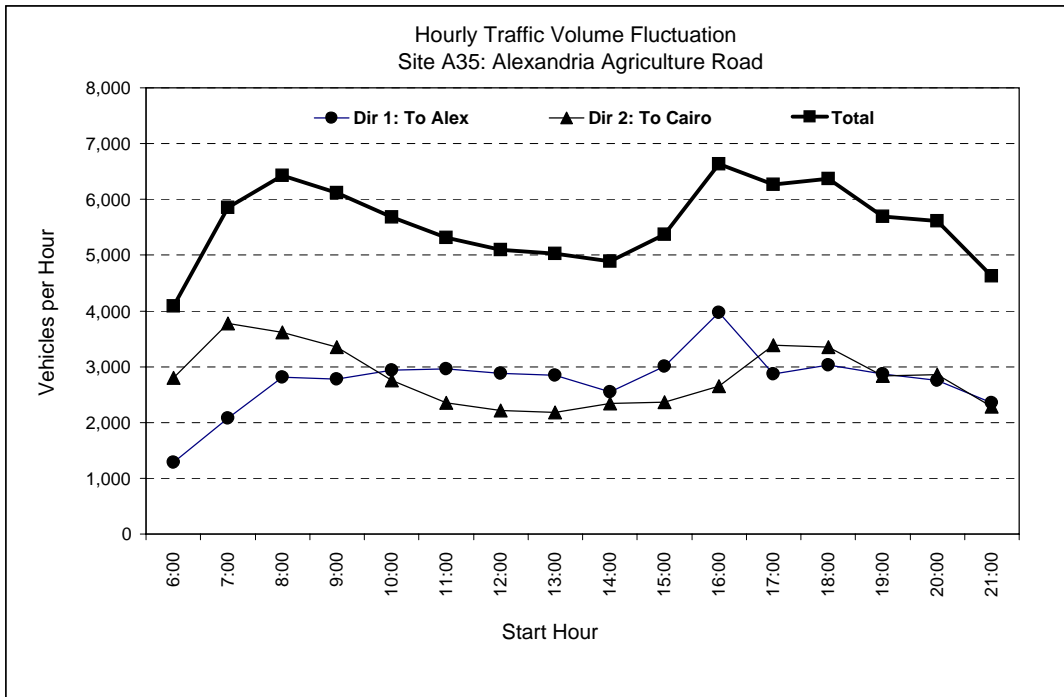

Appendix 3.5-14: Fluctuation and Composition of Traffic Volume at Ismailia Agriculture Road (A36)

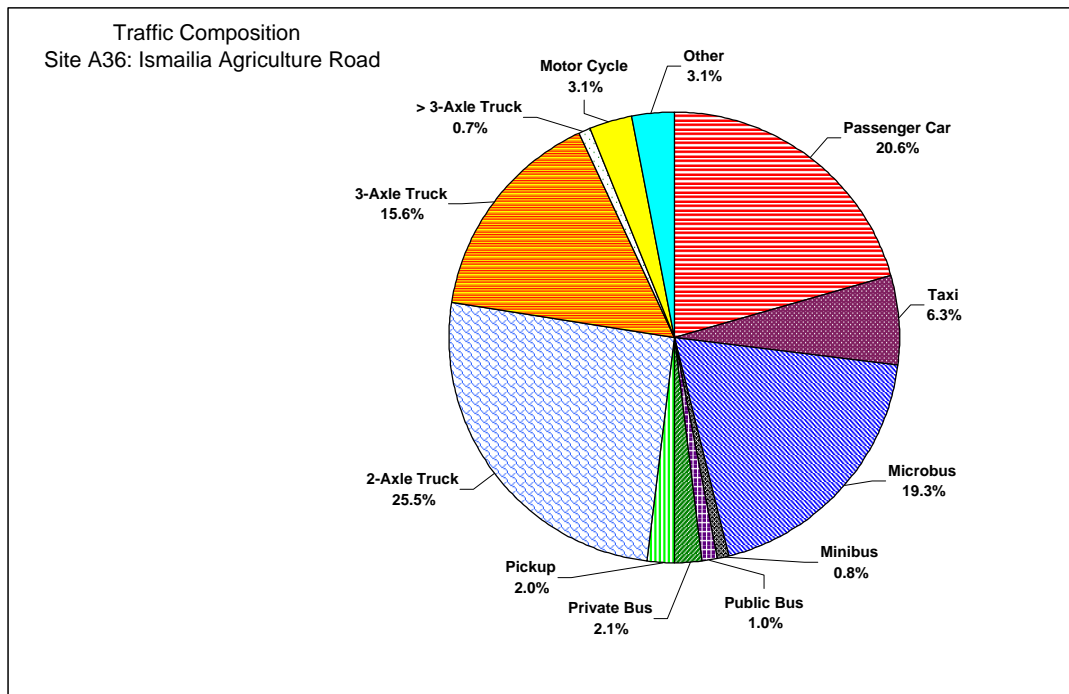
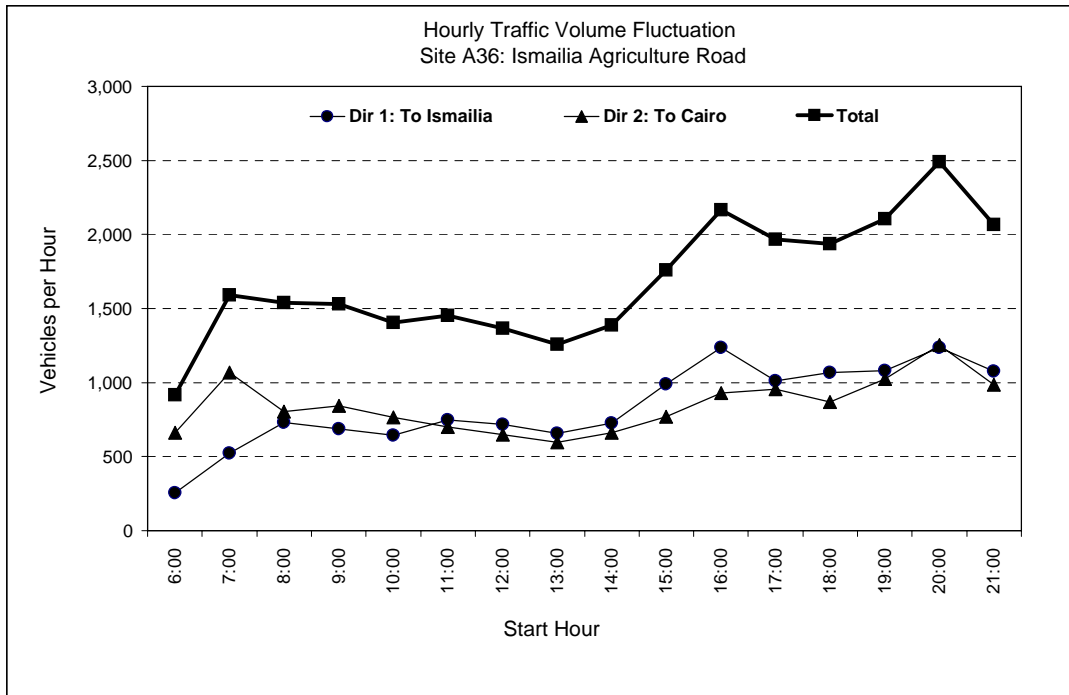

Appendix 3.5-15: Fluctuation and Composition of Traffic Volume at Ismailia Desert Road (A39)

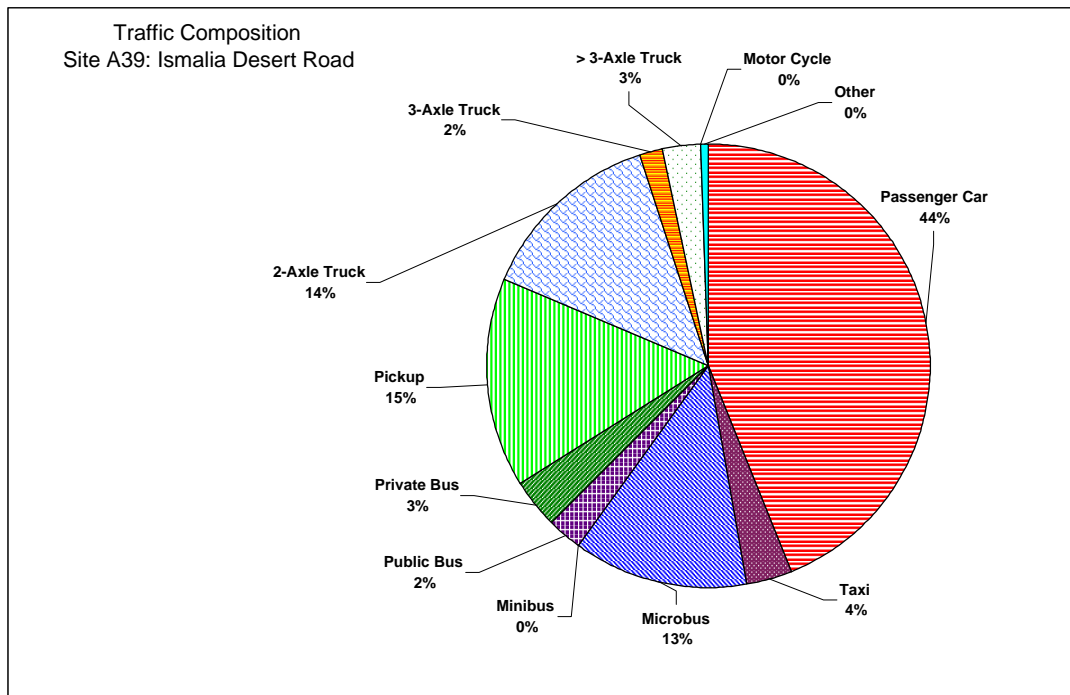
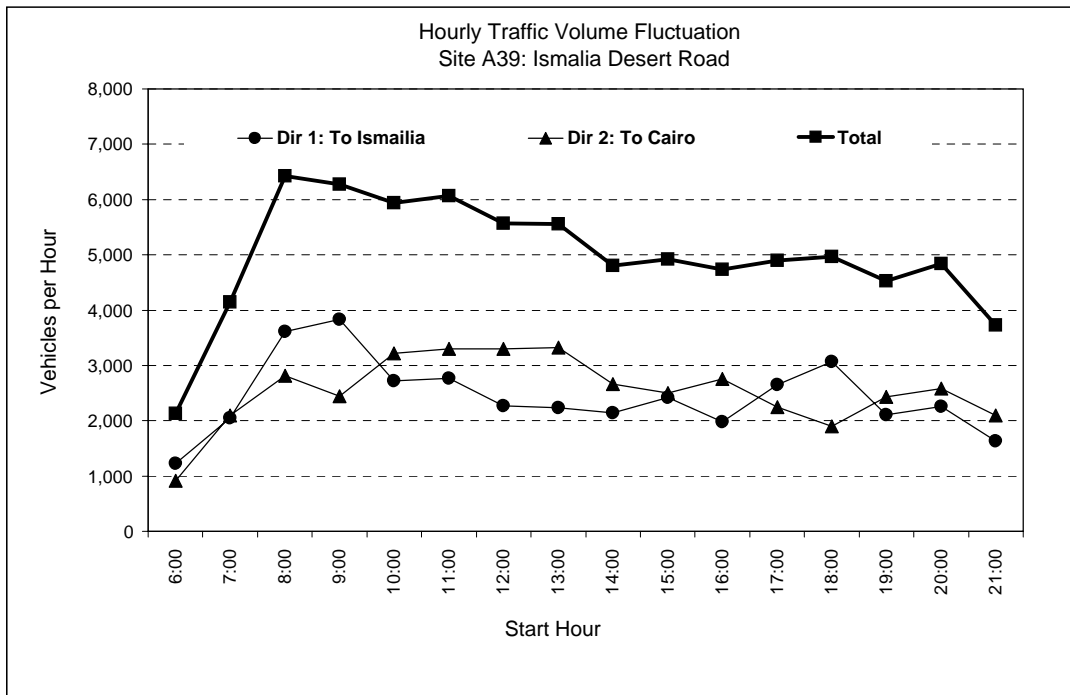

Appendix 3.5-16: Fluctuation and Composition of Traffic Volume at Autostrade (A42)

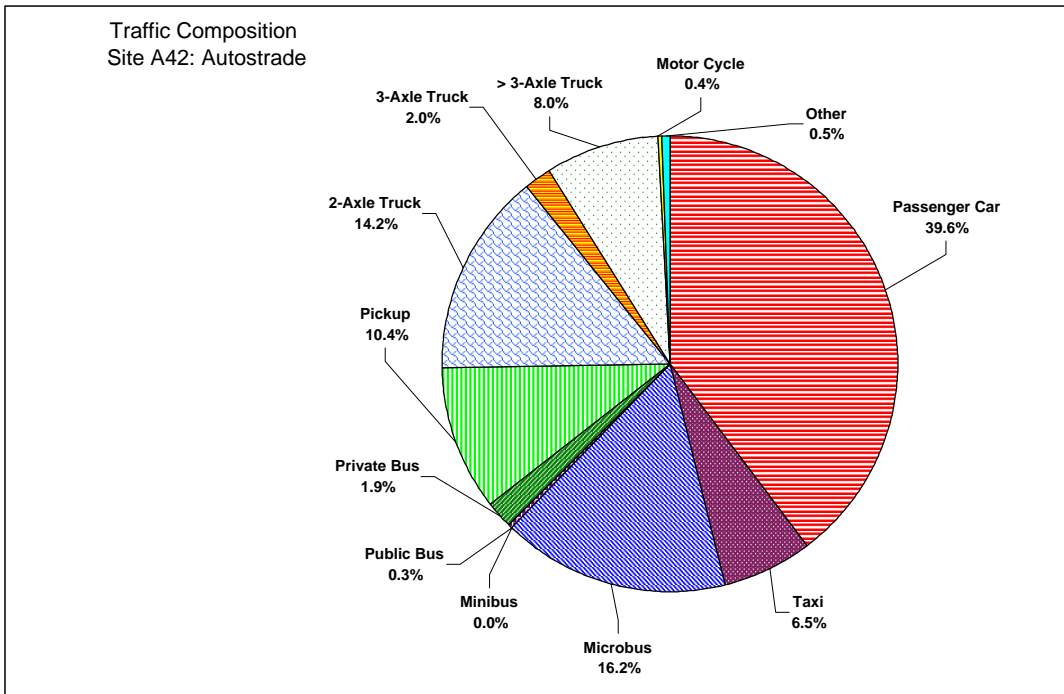
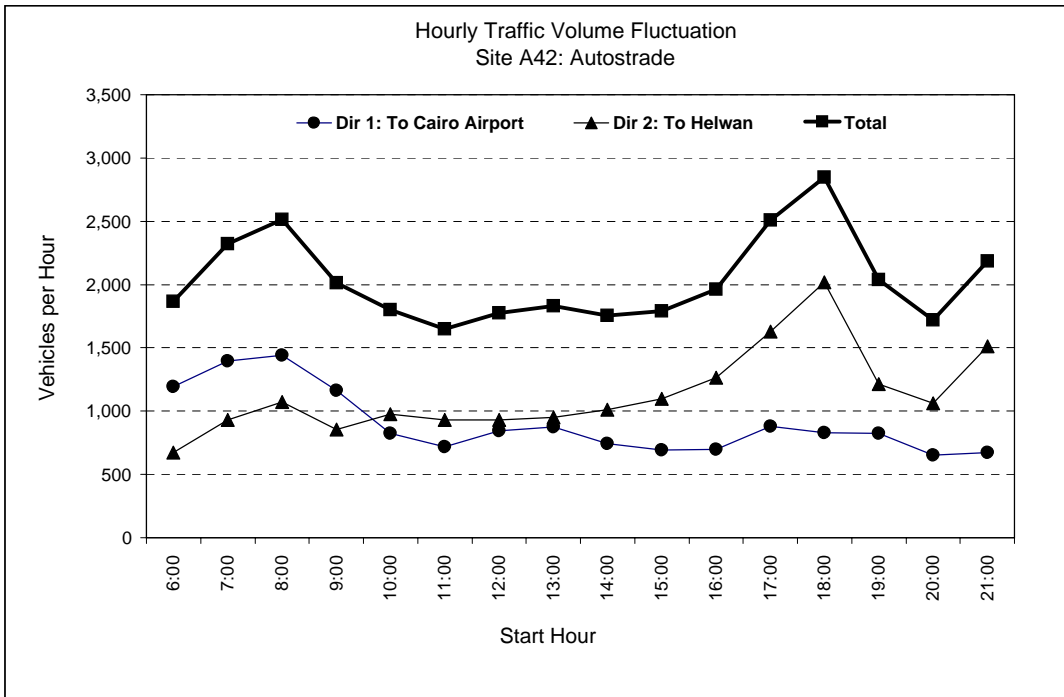

Appendix 3.5-17: Fluctuation and Composition of Traffic Volume at Nasr Road (AC20)

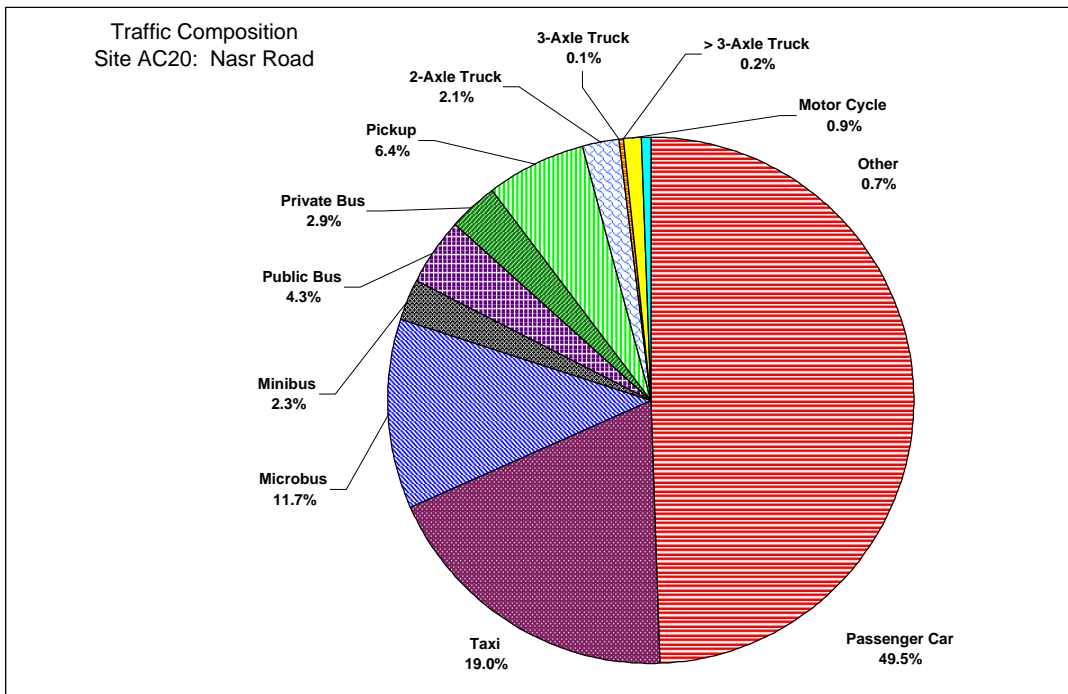
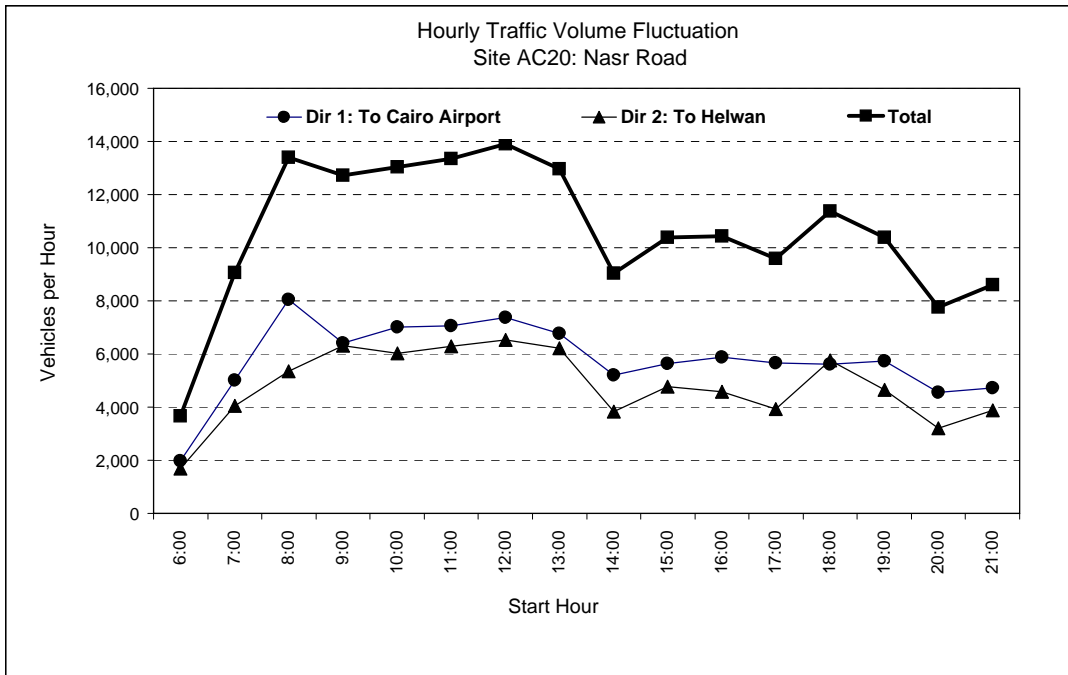

Appendix 3.5-18: Fluctuation and Composition of Traffic Volume at Gesr El-Suez St. (NW01)

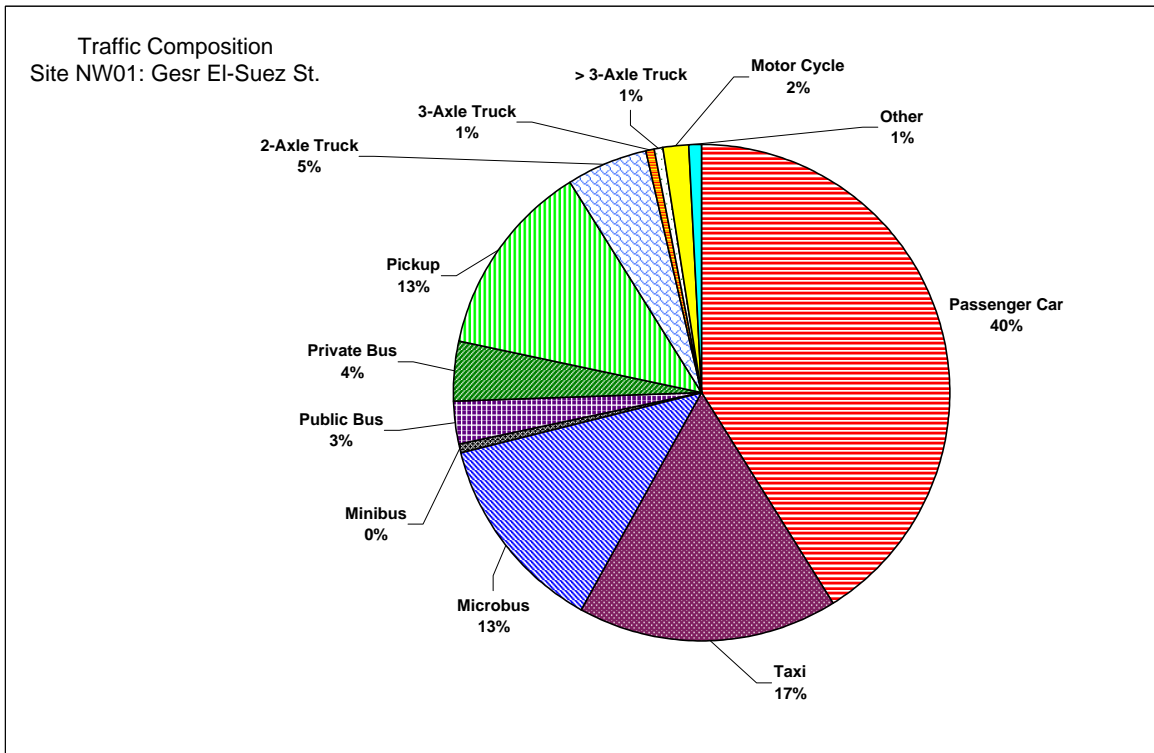
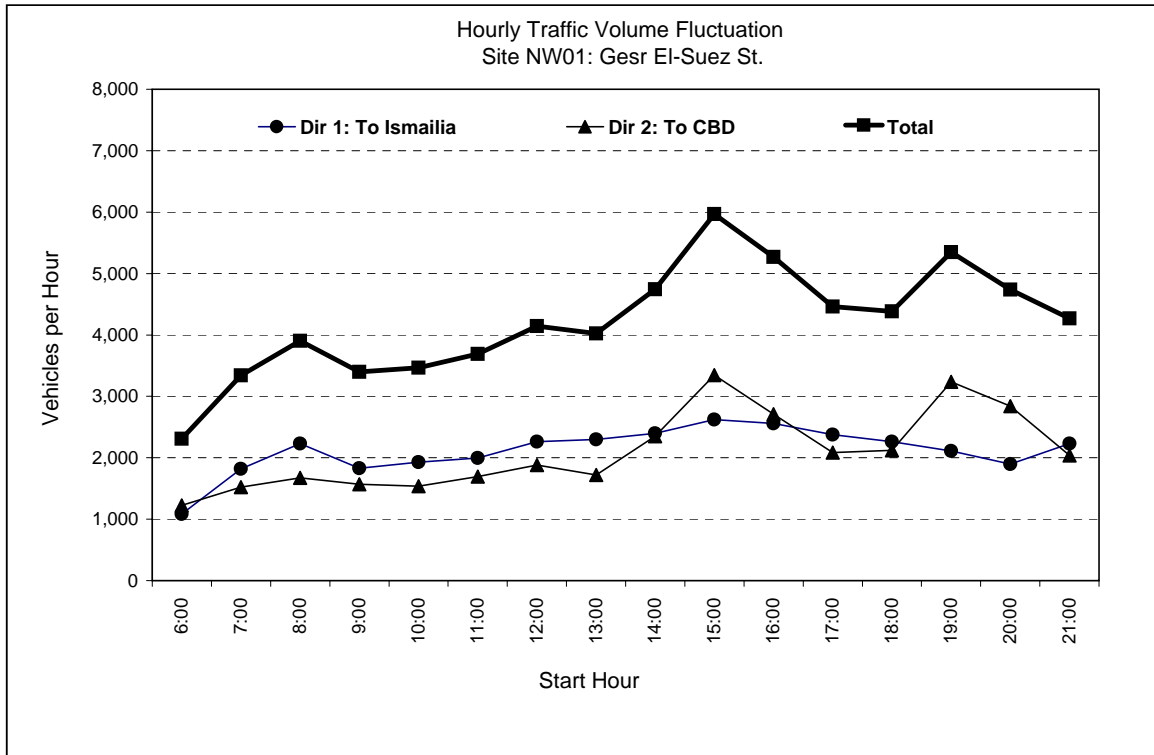

Appendix 3.5-19: Fluctuation and Composition of Traffic Volume at Suez Desert Road (NW02)

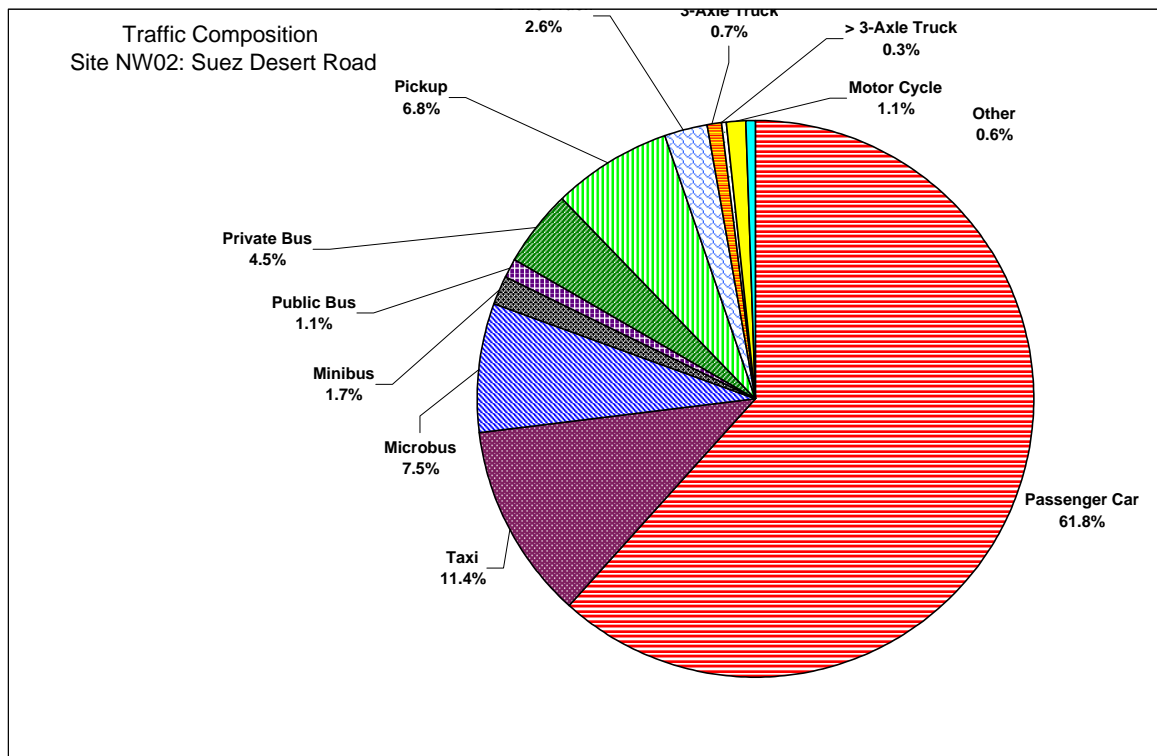
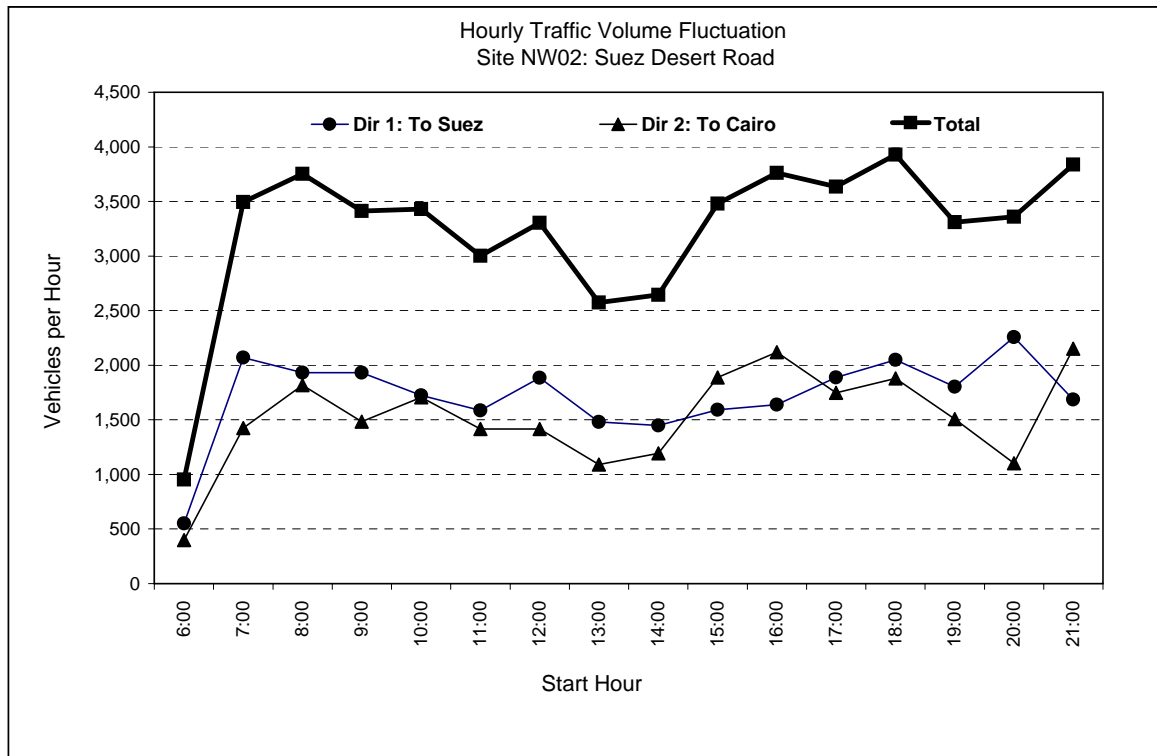

Appendix 3.5-20: Fluctuation and Composition of Traffic Volume at Abo Bakr El-Sedeeq St. (NW03)

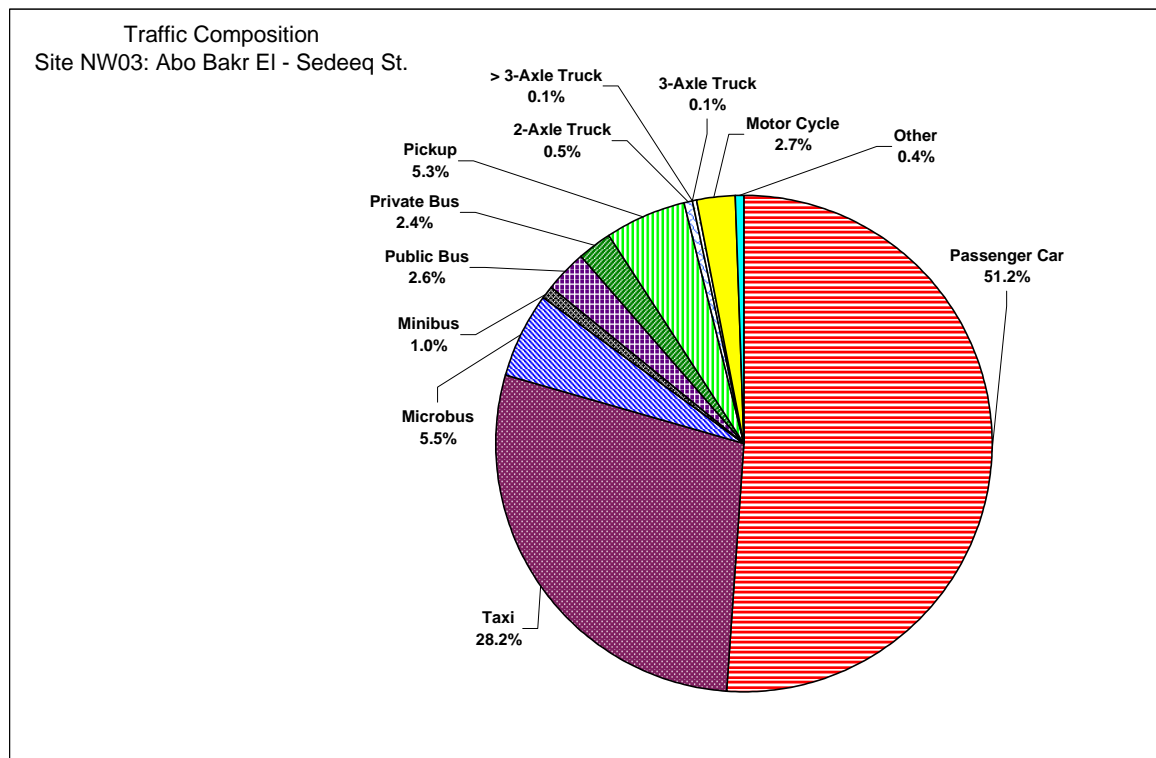
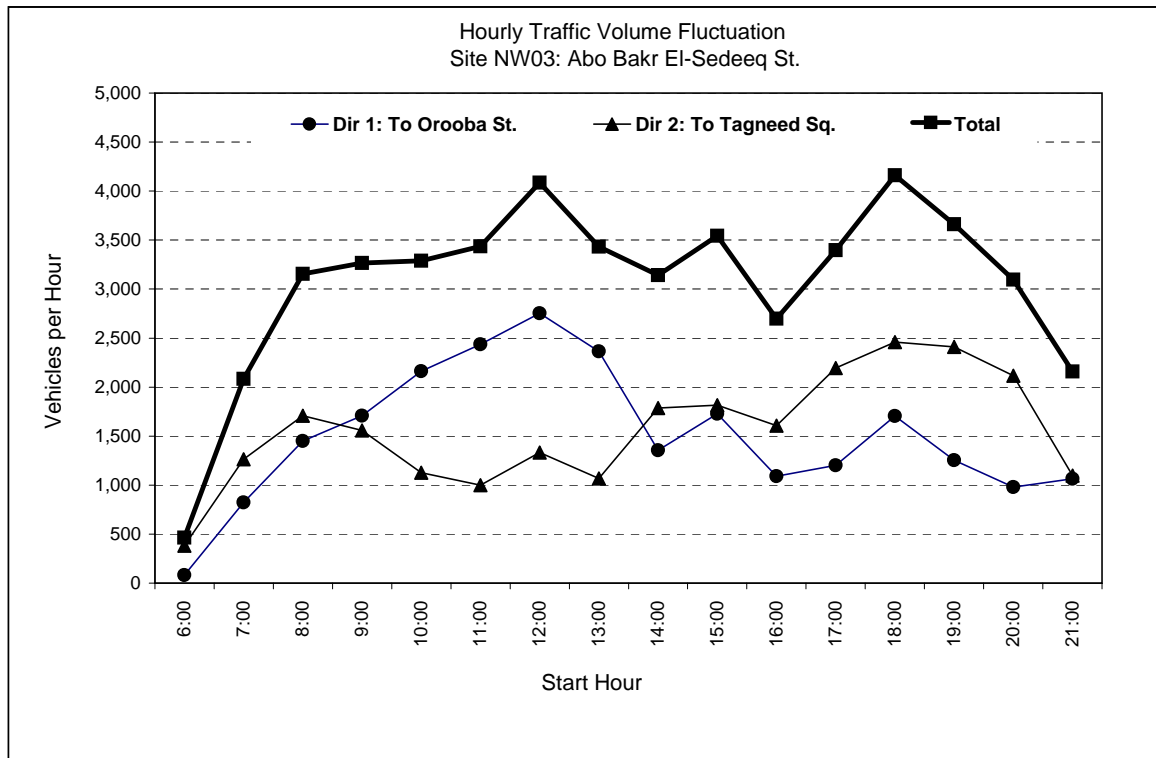

Appendix 3.5-21: Fluctuation and Composition of Traffic Volume at Kablat St. (NW04)

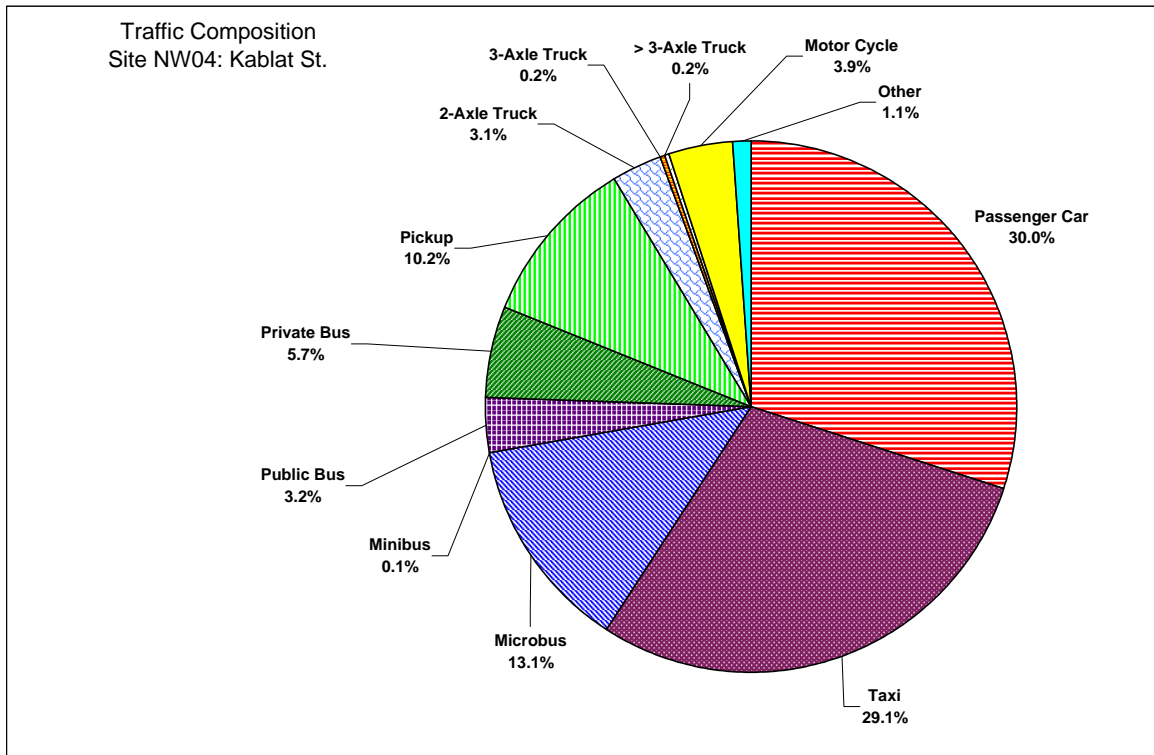
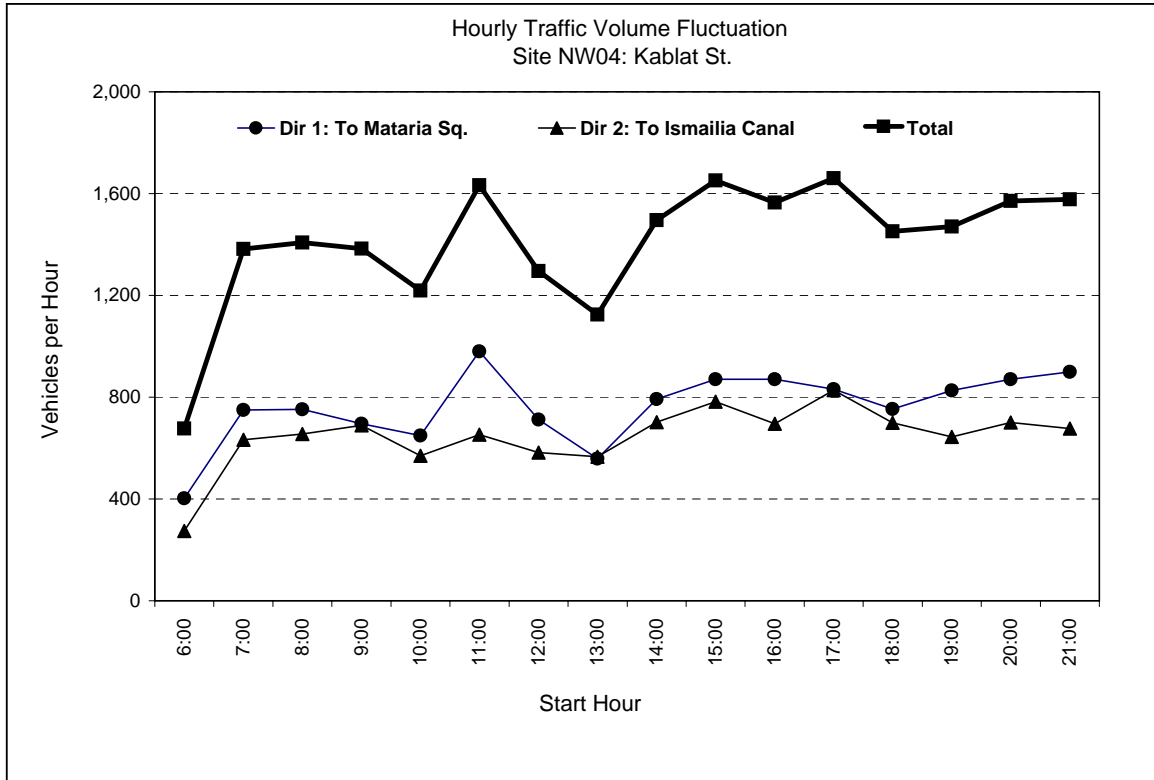

Appendix 3.5-22 Fluctuation and Composition of Traffic Volume at Lotfy El-Sayed St. (NW05)

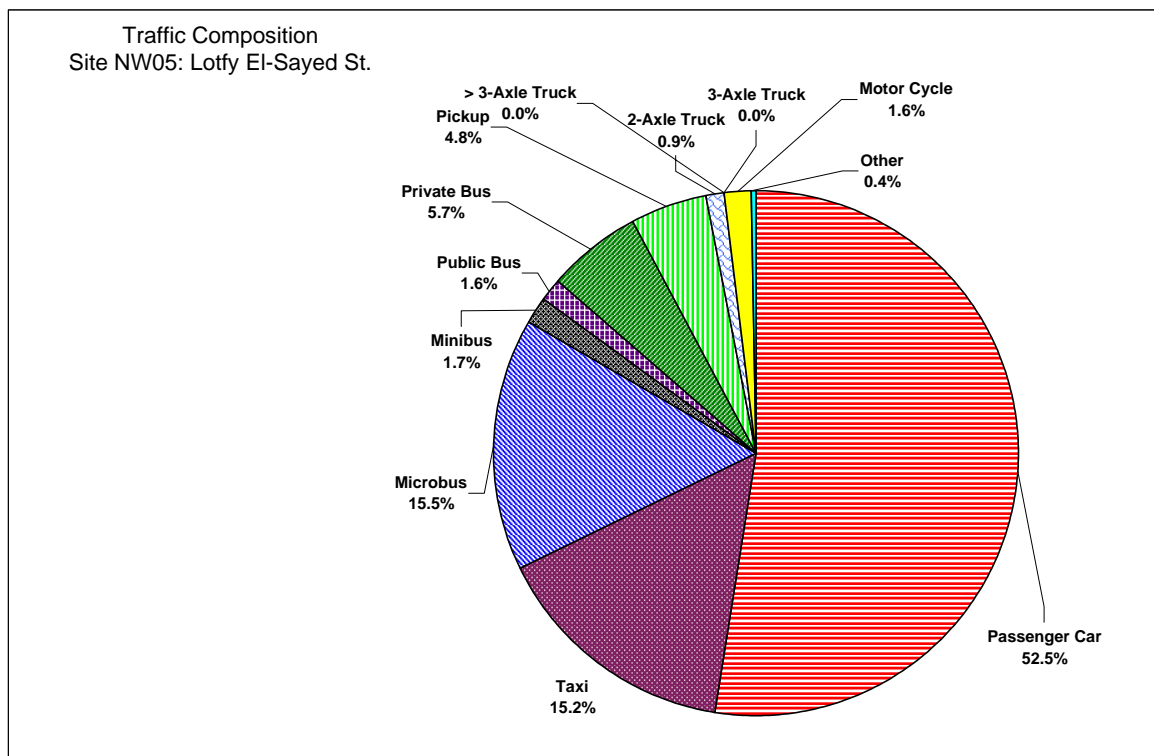
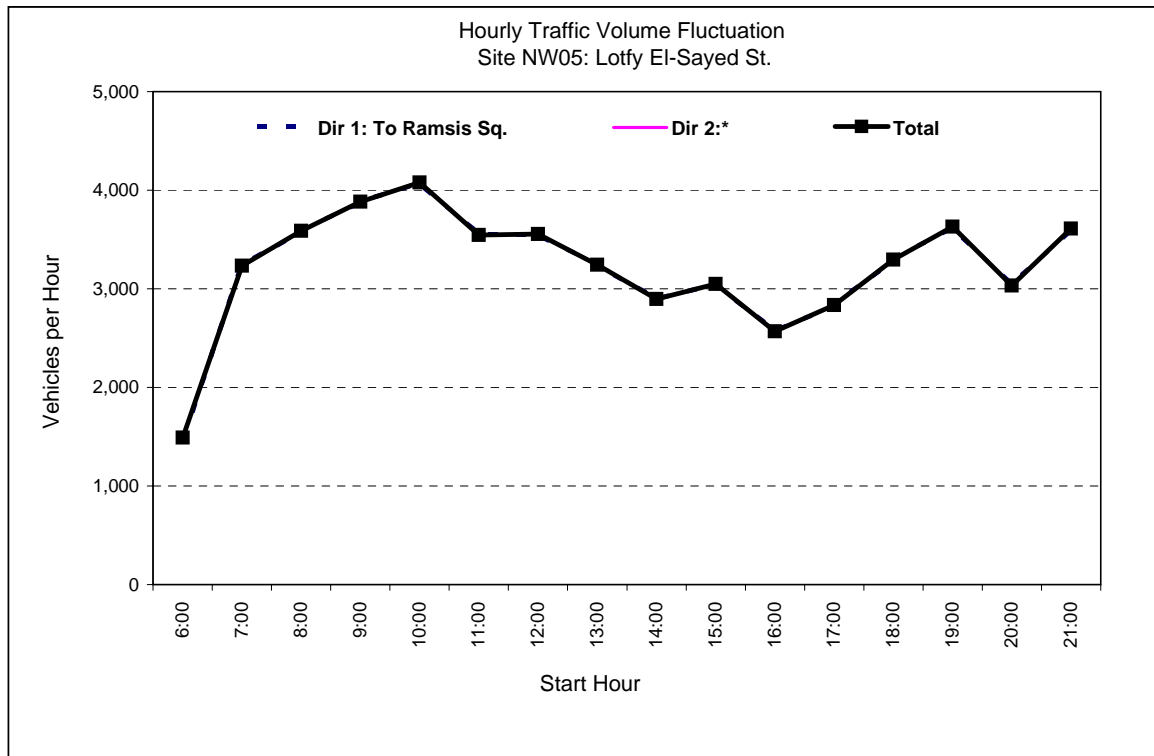

Appendix 3.5-23 Fluctuation and Composition of Traffic Volume at Autostrade (NW06)

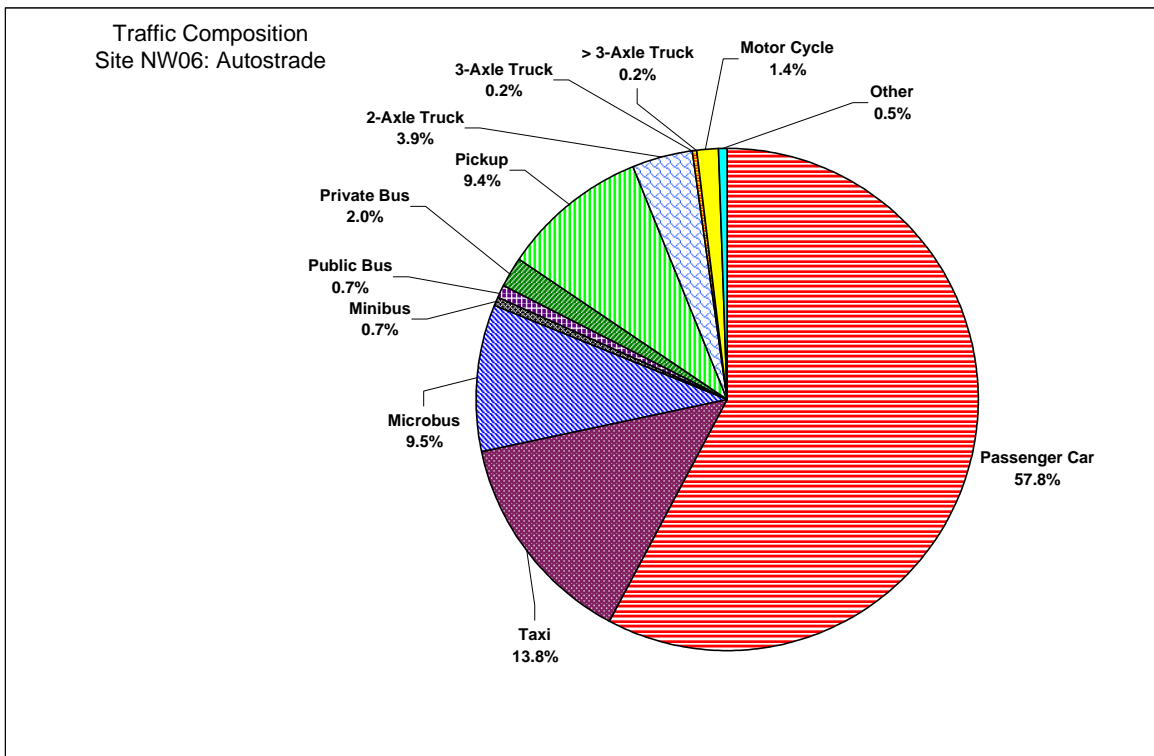
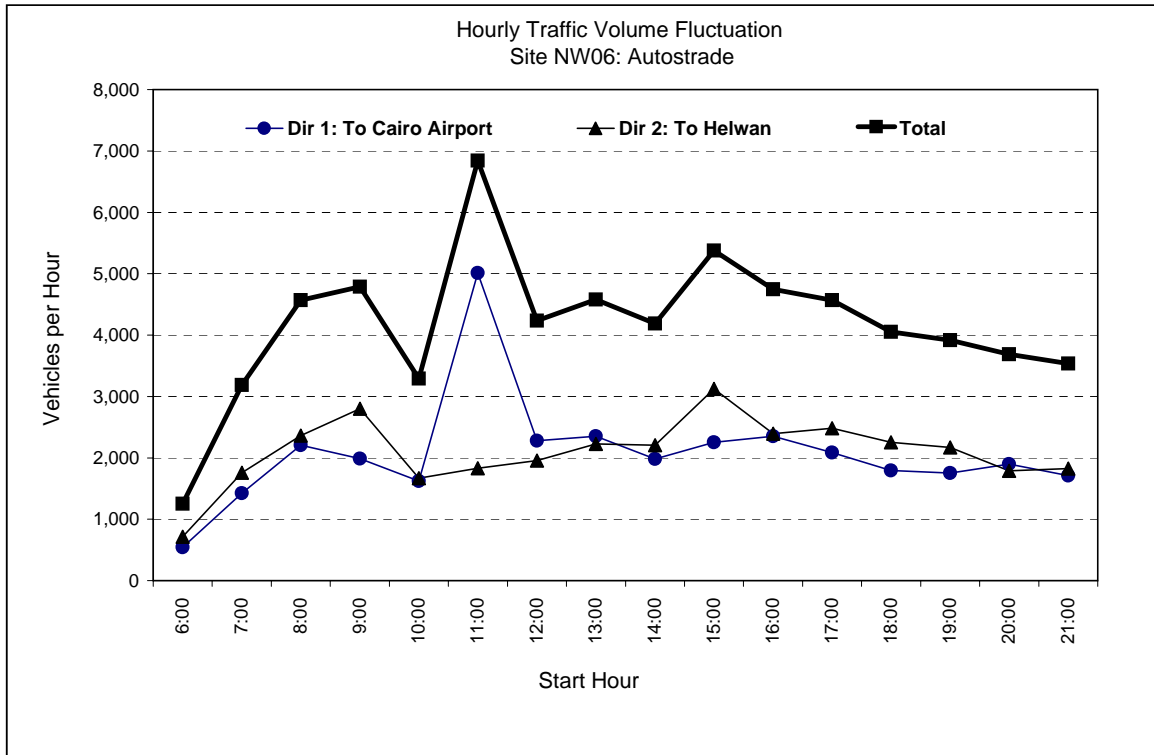

Appendix 3.5-24 Fluctuation and Composition of Traffic Volume at Ahmed Helmy St. (NW07)

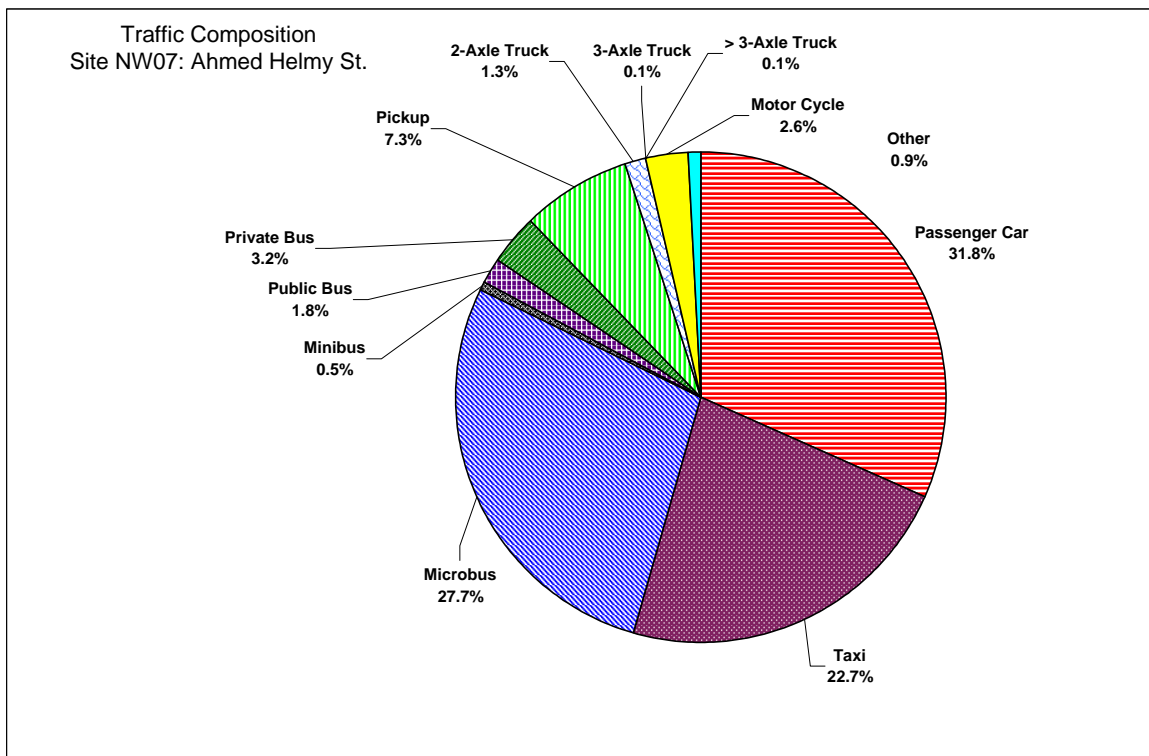
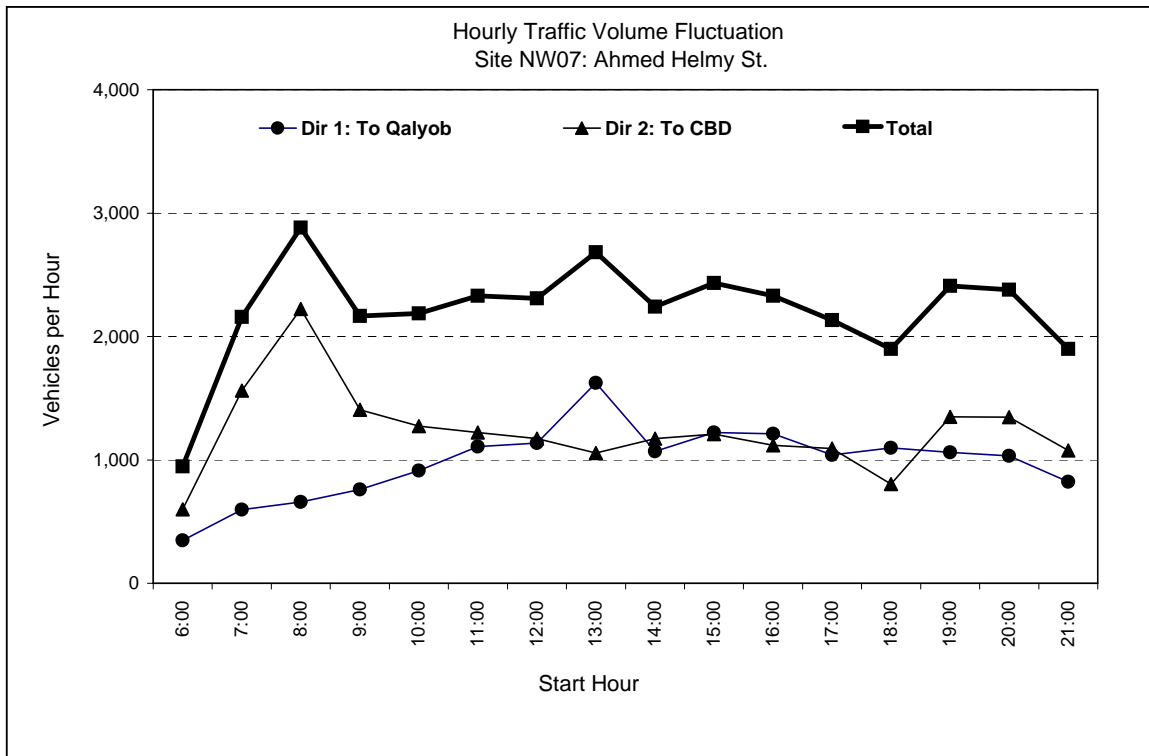

Appendix 3.5-25 Fluctuation and Composition of Traffic Volume at Ramsis St. (NW08)

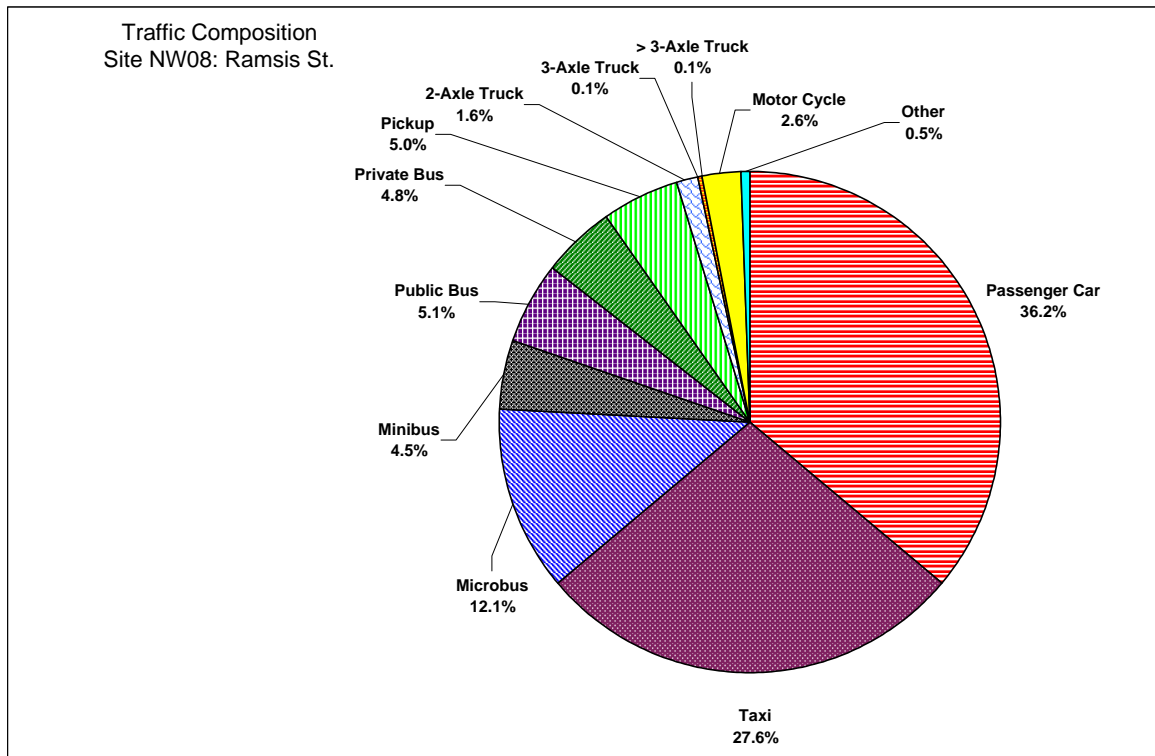
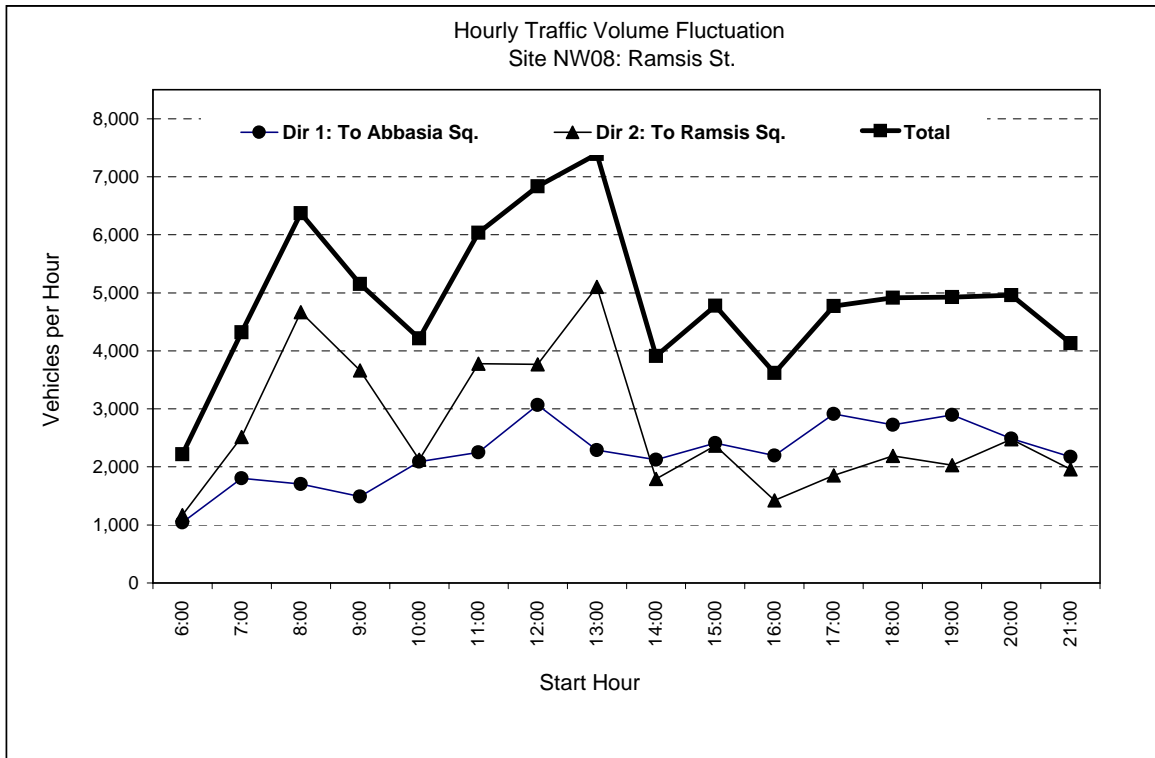

Appendix 3.5-26 Fluctuation and Composition of Traffic Volume at Salah Salem Road (NW09)

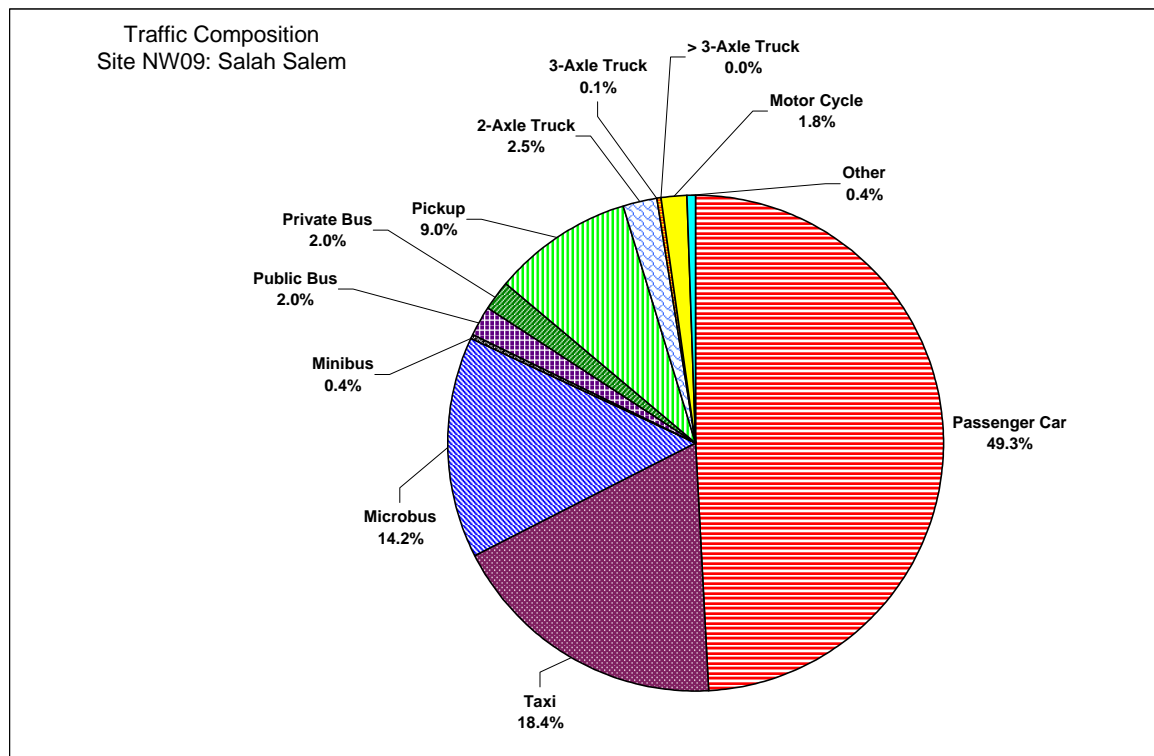
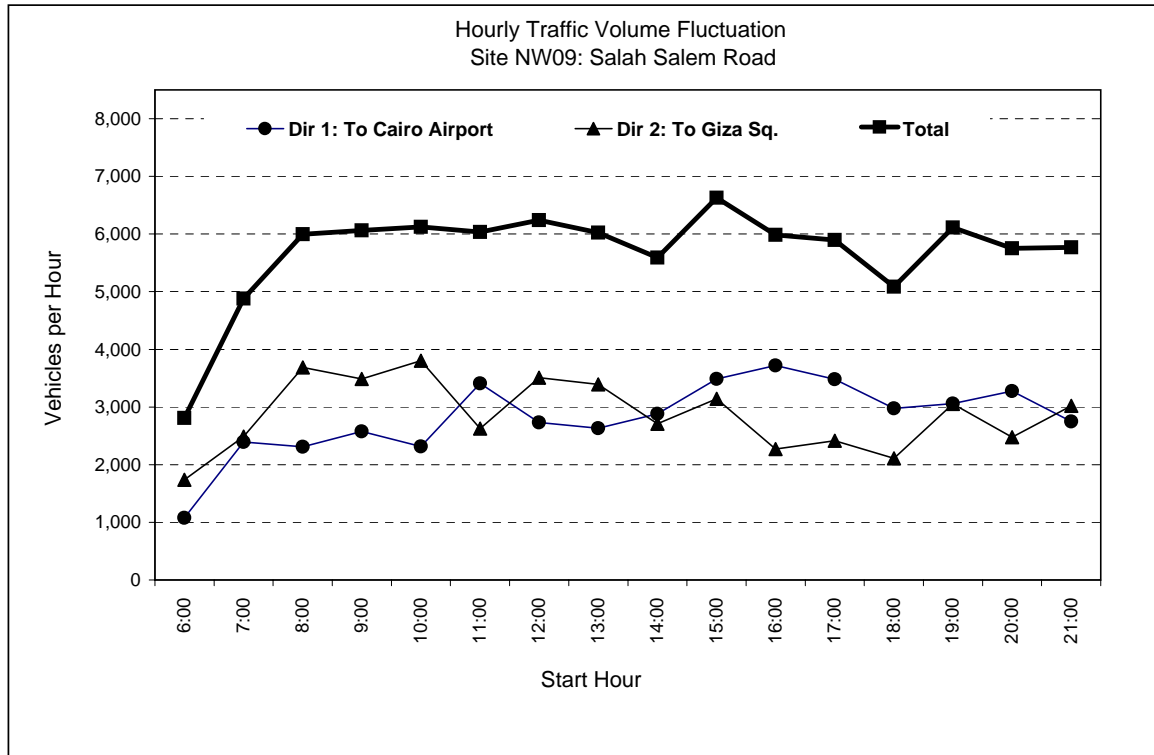

Appendix 3.5-27 Fluctuation and Composition of Traffic Volume at Tereat El-Zomor St. (NW10)

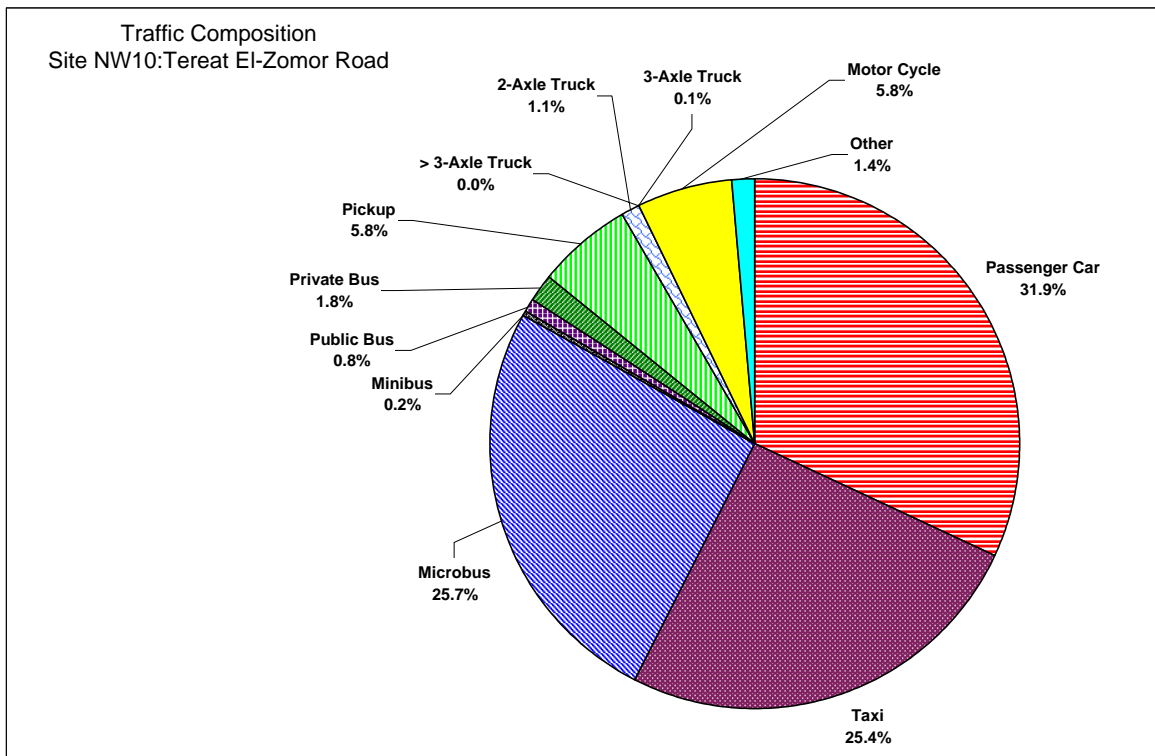
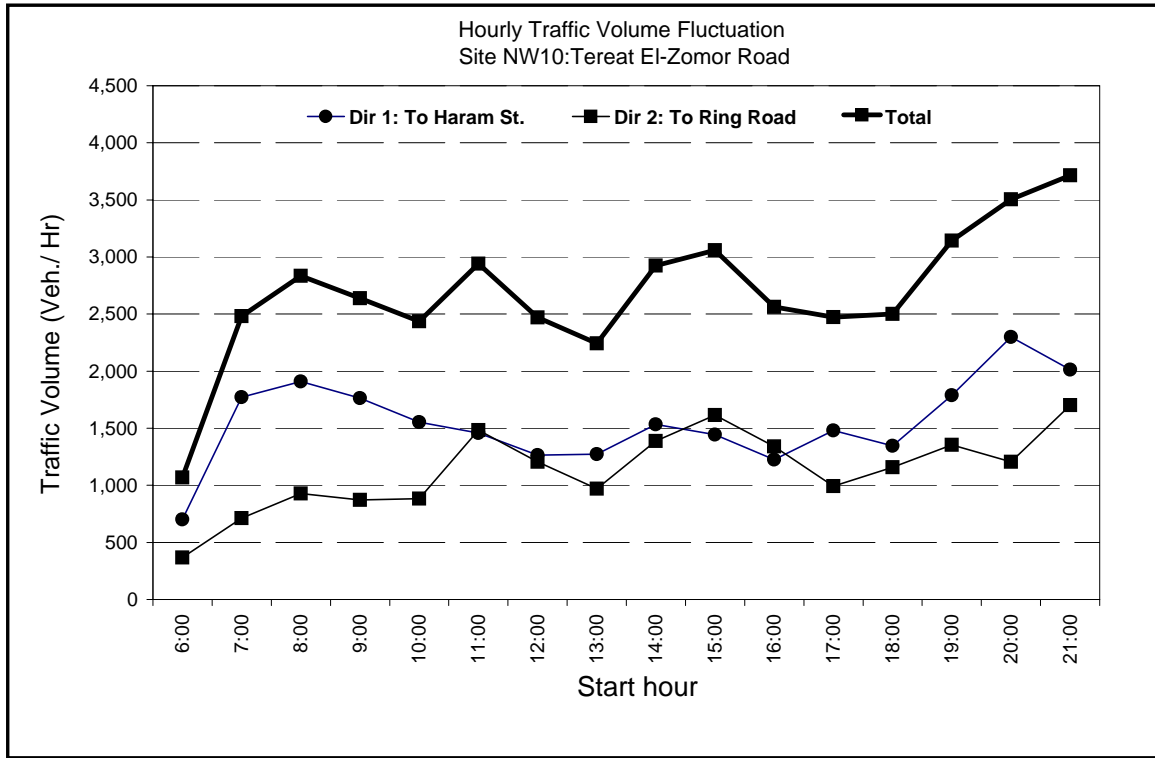

Appendix 3.5-28 Fluctuation and Composition of Traffic Volume at Sudan St. (NW11)

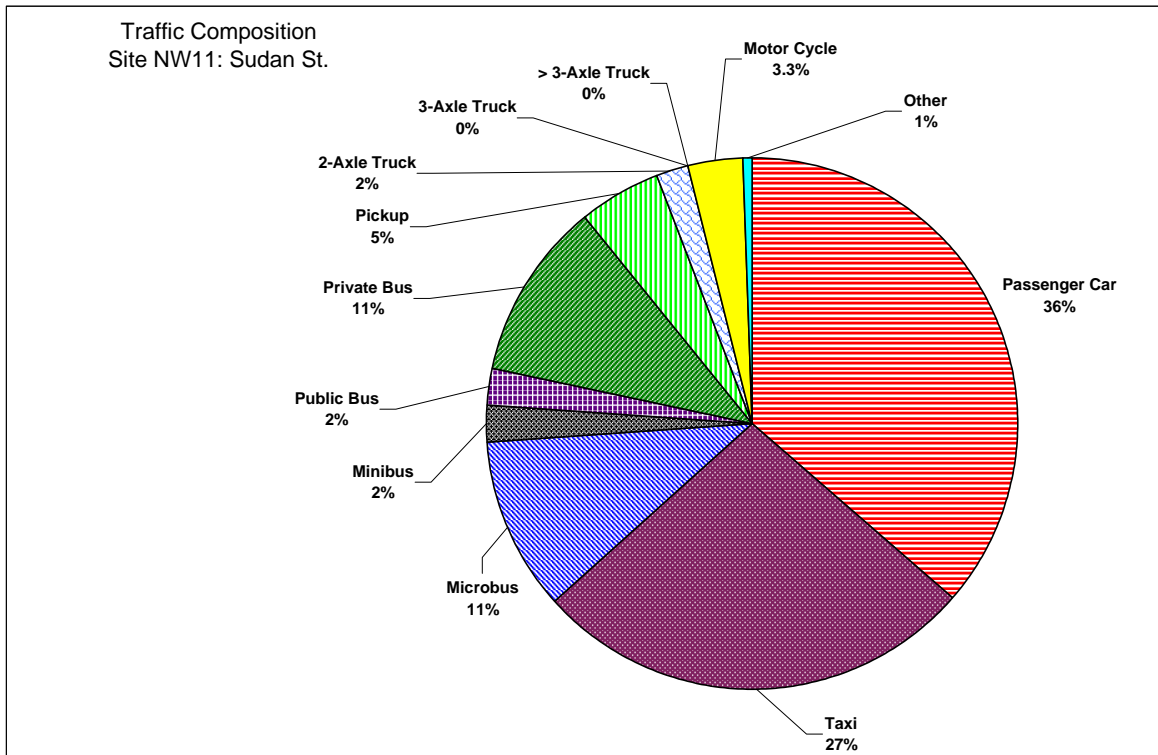
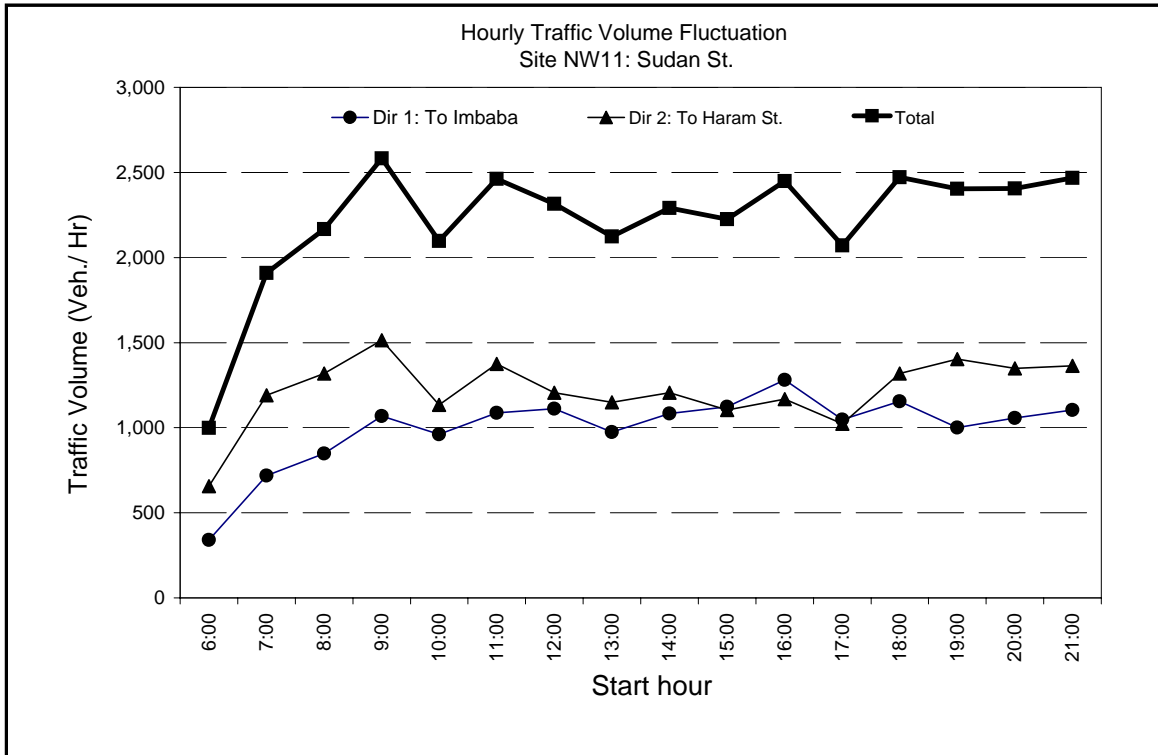

APPENDIX 3.6

SUMMARY OF TRAFFIC COUNT DATA

Appendix 3.6-1: Summary of Traffic Count Data for Bridges in 2005 (Unit: Vehicles)

Site	Direction	Duration	Number of Vehicles												Total
			Car	Taxi	Bus				Truck				Motorcycle	Other	
					Shared Taxi	Mini	Public	Private	Pickup	2-Axle	3-Axle	> 3 Axle			
B01	1	16	6,931	1,054	3,632	8	76	587	5,051	4,851	200	2,093	206	131	24,820
	2	16	6,311	830	2,916	80	24	769	4,901	3,390	169	1,495	177	110	21,172
	Total		13,242	1,884	6,548	88	100	1,356	9,952	8,241	369	3,588	383	241	45,992
	24 Hours		15,899	2,317	7,792	98	113	1,464	11,629	10,282	496	5,343	451	278	56,161
	Percent		28.3	4.1	13.9	0.2	0.2	2.6	20.7	18.3	0.9	9.5	0.8	0.5	100.0
B02	1	16	13,606	12,416	8,461	92	430	861	4,138	1,710	156	133	1,813	297	44,113
	2	16	10,457	9,774	7,220	478	1,343	1,487	5,027	1,875	250	144	1,082	416	39,553
	Total		24,063	22,190	15,681	570	1,773	2,348	9,165	3,585	406	277	2,895	713	83,666
	24 Hours		28,892	27,286	18,660	633	2,003	2,536	10,710	4,473	545	412	3,406	822	100,379
	Percent		28.8	27.2	18.6	0.6	2.0	2.5	10.7	4.5	0.5	0.4	3.4	0.8	100.0
B03	1	16	2,376	2,375	1,361	0	0	16	629	467	1	0	1,122	153	8,500
	2	16	2,777	3,050	4,739	2	0	32	987	179	0	0	1,124	184	13,074
	Total		5,153	5,425	6,100	2	0	48	1,616	646	1	0	2,246	337	21,574
	24 Hours		6,187	6,671	7,259	2	0	52	1,888	806	1	0	2,643	389	25,898
	Percent		23.9	25.8	28.0	0.0	0.0	0.2	7.3	3.1	0.0	0.0	10.2	1.5	100.0
B04	1	16	21,460	12,955	7,737	1,099	218	1,160	988	77	13	1	1,622	126	47,456
	2	16	33,622	16,846	4,945	4,046	980	2,547	4,421	1,030	47	6	2,566	36	71,092
	Total		55,082	29,801	12,682	5,145	1,198	3,707	5,409	1,107	60	7	4,188	162	118,548
	24 Hours		66,135	36,644	15,092	5,711	1,354	4,004	6,321	1,381	81	10	4,928	187	141,847
	Percent		46.6	25.8	10.6	4.0	1.0	2.8	4.5	1.0	0.1	0.0	3.5	0.1	100.0
B05	1	16	104,226	23,001	2,935	454	1,630	3,310	5,084	1,765	12	20	2,317	232	144,986
	2	16	74,511	21,803	8,441	692	1,155	1,516	3,876	464	15	24	2,176	139	114,812
	Total		178,737	44,804	11,376	1,146	2,785	4,826	8,960	2,229	27	44	4,493	371	259,798
	24 Hours		214,604	55,093	13,537	1,272	3,147	5,212	10,470	2,781	36	66	5,287	428	311,933
	Percent		68.8	17.7	4.3	0.4	1.0	1.7	3.4	0.9	0.0	0.0	1.7	0.1	100.0
B06	1	16	13,648	9,648	1,333	534	1,155	601	984	64	6	10	1,031	55	29,069
	2	16	12,161	9,145	1,203	732	1,425	518	643	150	1	4	755	96	26,833
	Total		25,809	18,793	2,536	1,266	2,580	1,119	1,627	214	7	14	1,786	151	55,902
	24 Hours		30,988	23,109	3,018	1,405	2,915	1,209	1,901	267	9	21	2,102	174	67,118
	Percent		46.2	34.4	4.5	2.1	4.3	1.8	2.8	0.4	0.0	0.0	3.1	0.3	100.0
B07	1	16	17,420	9,842	1,512	348	1,030	638	1,194	27	0	5	699	92	32,807
	2	16	17,585	12,163	2,892	783	1,208	748	1,259	317	2	6	976	245	38,184
	Total		35,005	22,005	4,404	1,131	2,238	1,386	2,453	344	2	11	1,675	337	70,991
	24 Hours		42,029	27,058	5,241	1,255	2,529	1,497	2,866	429	3	16	1,971	389	85,284
	Percent		49.3	31.7	6.1	1.5	3.0	1.8	3.4	0.5	0.0	0.0	2.3	0.5	100.0
B08	1	16	16,529	10,366	4,844	124	556	1,171	2,816	1,070	7	14	1,313	399	39,209
	2	16	18,754	12,666	5,334	431	691	977	2,010	519	63	35	1,281	455	43,216
	Total		35,283	23,032	10,178	555	1,247	2,148	4,826	1,589	70	49	2,594	854	82,425
	24 Hours		42,363	28,321	12,112	616	1,409	2,320	5,639	1,983	94	73	3,052	985	98,967
	Percent		42.8	28.6	12.2	0.6	1.4	2.3	5.7	2.0	0.1	0.1	3.1	1.0	100.0
B09	1	16	26,222	5,798	2,854	273	125	1,164	3,259	1,924	759	695	492	142	43,707
	2	16	35,595	7,724	4,344	36	115	1,577	5,695	3,021	531	741	633	347	60,359
	Total		61,817	13,522	7,198	309	240	2,741	8,954	4,945	1,290	1,436	1,125	489	104,066
	24 Hours		74,222	16,627	8,566	343	271	2,960	10,463	6,170	1,733	2,138	1,324	564	125,381
	Percent		59.2	13.3	6.8	0.3	0.2	2.4	8.3	4.9	1.4	1.7	1.1	0.4	100.0
B10	1	16	1,292	61	1,124	17	64	421	1,747	996	48	226	47	245	6,288
	2	16	1,207	44	1,123	3	11	489	1,716	934	44	324	78	233	6,206
	Total		2,499	105	2,247	20	75	910	3,463	1,930	92	550	125	478	12,494
	24 Hours		3,000	129	2,674	22	85	983	4,047	2,408	124	819	147	551	14,989
	Percent		20.0	0.9	17.8	0.1	0.6	6.6	27.0	16.1	0.8	5.5	1.0	3.7	100.0
Sub-Tot	Total		436,690	181,561	78,950	10,232	12,236	20,589	56,425	24,830	2,324	5,976	21,510	4,133	855,456
	24 Hours		524,320	223,254	93,951	11,358	13,827	22,236	65,936	30,980	3,122	8,898	25,310	4,766	1,027,957
	Percent		51.0	21.7	9.1	1.1	1.3	2.2	6.4	3.0	0.3	0.9	2.5	0.5	100.0

Appendix 3.6-2: Summary of Traffic Count Data for Some Major Arterials in 2005 (Unit: Vehicles)

A3-6-2

Site	Direction	Duration	Number of Vehicles												
					Bus				Truck						Total
			Car	Taxi	Shared Taxi	Mini	Public	Private	Pickup	2-Axle	3-Axle	> 3 Axle	Motorcycle	Other	
A18 26th of July Corridor	1	16	33,592	2,582	4,464	37	240	1,325	485	169	13	2	143	44	43,096
	2	16	23,884	2,718	3,913	658	370	839	2,090	513	90	46	212	10	35,343
	Total		57,476	5,300	8,377	695	610	2,164	2,575	682	103	48	355	54	78,439
	24 Hours		69,010	6,517	9,969	771	689	2,337	3,009	851	138	71	418	62	93,843
	Percent		73.5	6.9	10.6	0.8	0.7	2.5	3.2	0.9	0.1	0.1	0.4	0.1	100.0
A21 Suez Road	1	16	12,823	370	1,131	14	79	822	1,044	330	31	173	72	196	17,085
	2	16	14,208	378	958	9	104	1,082	1,094	430	51	137	82	248	18,781
	Total		27,031	748	2,089	23	183	1,904	2,138	760	82	310	154	444	35,866
	24 Hours		32,455	920	2,486	26	207	2,056	2,498	948	110	462	181	512	42,861
	Percent		75.7	2.1	5.8	0.1	0.5	4.8	5.8	2.2	0.3	1.1	0.4	1.2	100.0
A35 Alex Agriculture Road	1	16	12,080	1,357	12,004	2,000	1,047	824	6,353	5,218	583	2,043	350	100	43,959
	2	16	12,977	1,503	11,264	16	871	3,681	6,634	4,866	922	1,825	485	77	45,121
	Total		25,057	2,860	23,268	2,016	1,918	4,505	12,987	10,084	1,505	3,868	835	177	89,080
	24 Hours		30,085	3,517	27,689	2,238	2,167	4,865	15,176	12,581	2,021	5,760	983	204	107,287
	Percent		28.0	3.3	25.8	2.1	2.0	4.5	14.1	11.7	1.9	5.4	0.9	0.2	100.0
A36 Ismailia Agriculture Road	1	16	2,799	654	2,687	20	533	320	3,506	2,195	34	417	341	117	13,623
	2	16	2,695	1,011	2,446	186	522	217	3,283	1,949	157	402	483	195	13,546
	Total		5,494	1,665	5,133	206	1,055	537	6,789	4,144	191	819	824	312	27,169
	24 Hours		6,596	2,047	6,108	229	1,192	580	7,933	5,170	257	1,220	970	360	32,662
	Percent		20.2	6.3	18.7	0.7	3.6	1.8	24.3	15.8	0.8	3.7	3.0	1.1	100.0
A39 Ismailia Desert Road	1	16	18,621	1,355	4,662	6	1,158	1,628	5,371	4,284	586	983	76	230	38,960
	2	16	16,211	1,451	5,502	5	822	1,058	6,899	6,547	644	1,225	49	161	40,574
	Total		34,832	2,806	10,164	11	1,980	2,686	12,270	10,831	1,230	2,208	125	391	79,534
	24 Hours		41,822	3,450	12,095	12	2,237	2,901	14,338	13,514	1,652	3,288	147	451	95,907
	Percent		43.6	3.6	12.6	0.0	2.3	3.0	15.0	14.1	1.7	3.4	0.2	0.5	100.0
A42 Autostrade	1	16	6,042	1,063	2,323	3	31	205	1,535	1,613	282	1,219	45	84	14,445
	2	16	6,859	1,050	2,948	4	53	418	1,845	3,015	382	1,388	86	86	18,134
	Total		12,901	2,113	5,271	7	84	623	3,380	4,628	664	2,607	131	170	32,579
	24 Hours		15,490	2,598	6,272	8	95	673	3,950	5,774	892	3,882	154	196	39,984
	Percent		38.7	6.5	15.7	0.0	0.2	1.7	9.9	14.4	2.2	9.7	0.4	0.5	100.0
AC20 Nasr Road	1	16	49,272	16,673	11,937	1,358	2,605	2,175	5,923	1,415	133	201	681	301	92,674
	2	16	34,680	15,531	7,848	2,569	4,675	2,746	4,856	2,215	81	88	909	842	77,040
	Total		83,952	32,204	19,785	3,927	7,280	4,921	10,779	3,630	214	289	1,590	1,143	169,714
	24 Hours		100,799	39,599	23,544	4,359	8,226	5,315	12,596	4,529	287	430	1,871	1,318	202,874
	Percent		49.7	19.5	11.6	2.1	4.1	2.6	6.2	2.2	0.1	0.2	0.9	0.6	100.0
Sub-Tot	Total		246,743	47,696	74,087	6,885	13,110	17,340	50,918	34,759	3,989	10,149	4,014	2,691	512,381
	24 Hours		296,257	58,649	88,164	7,642	14,814	18,727	59,500	43,368	5,358	15,112	4,723	3,103	615,417
	Percent		48.1	9.5	14.3	1.2	2.4	3.0	9.7	7.0	0.9	2.5	0.8	0.5	100.0

Appendix 3.6-3: Summary of Traffic Count Data for New Sites in 2005 (Unit: Vehicles)

Site	Direction	Duration	Number of Vehicles												
			Car		Bus				Truck				Motorcycle	Other	Total
			Shared Taxi	Mini	Public	Private	Pickup	2-Axle	3-Axle	> 3 Axle					
NW01 Gesr El-Suez St.	1	16	12,503	6,651	4,475	290	793	1,015	4,660	1,907	244	180	581	258	33,557
	2	16	15,289	4,633	4,454	37	1,040	1,592	4,021	1,610	148	186	578	309	33,897
	Total		27,792	11,284	8,929	327	1,833	2,607	8,681	3,517	392	366	1,159	567	67,454
	24 Hours		33,369	13,875	10,626	363	2,071	2,816	10,144	4,388	527	545	1,364	654	80,741
	Percent		41.3	17.2	13.2	0.4	2.6	3.5	12.6	5.4	0.7	0.7	1.7	0.8	100.0
NW02 Suez Desert Road	1	16	19,260	2,424	1,324	111	171	1,374	1,715	586	62	67	278	153	27,525
	2	16	12,791	3,484	2,546	765	384	970	1,800	747	309	103	270	178	24,347
	Total		32,051	5,908	3,870	876	555	2,344	3,515	1,333	371	170	548	331	51,872
	24 Hours		38,483	7,265	4,605	972	627	2,532	4,107	1,663	498	253	645	382	62,032
	Percent		62.0	11.7	7.4	1.6	1.0	4.1	6.6	2.7	0.8	0.4	1.0	0.6	100.0
NW03 Abo Bakr El-Sedeeg St.	1	16	11,615	6,938	1,646	434	787	697	1,402	165	61	23	646	131	24,545
	2	16	13,616	6,949	1,092	105	496	520	1,237	102	6	15	693	88	24,919
	Total		25,231	13,887	2,738	539	1,283	1,217	2,639	267	67	38	1,339	219	49,464
	24 Hours		30,294	17,076	3,258	598	1,450	1,314	3,084	333	90	57	1,576	253	59,382
	Percent		51.0	28.8	5.5	1.0	2.4	2.2	5.2	0.6	0.2	0.1	2.7	0.4	100.0
NW04 Kablat St.	1	16	3,394	3,793	1,652	11	408	664	1,251	392	28	18	491	112	12,214
	2	16	3,374	2,784	1,300	5	318	616	1,053	310	28	24	397	142	10,351
	Total		6,768	6,577	2,952	16	726	1,280	2,304	702	56	42	888	254	22,565
	24 Hours		8,126	8,087	3,513	18	820	1,382	2,692	876	75	63	1,045	293	26,991
	Percent		30.1	30.0	13.0	0.1	3.0	5.1	10.0	3.2	0.3	0.2	3.9	1.1	100.0
NW05 Lotfy El-Sayed St.	1	16	27,070	7,816	7,993	879	815	2,958	2,498	477	13	3	824	187	51,533
	2	16	0	0	0	0	0	0	0	0	0	0	0	0	0
	Total		27,070	7,816	7,993	879	815	2,958	2,498	477	13	3	824	187	51,533
	24 Hours		32,502	9,611	9,512	976	921	3,195	2,919	595	17	4	970	216	61,437
	Percent		52.9	15.6	15.5	1.6	1.5	5.2	4.8	1.0	0.0	0.0	1.6	0.4	100.0
NW06 Autostrade	1	16	18,382	4,706	1,904	227	222	646	2,449	946	67	61	453	162	30,225
	2	16	17,187	4,495	4,477	225	253	705	3,802	1,636	79	66	494	141	33,560
	Total		35,569	9,201	6,381	452	475	1,351	6,251	2,582	146	127	947	303	63,785
	24 Hours		42,707	11,314	7,593	502	537	1,459	7,305	3,221	196	189	1,114	349	76,486
	Percent		55.8	14.8	9.9	0.7	0.7	1.9	9.6	4.2	0.3	0.2	1.5	0.5	100.0
NW07 Ahmed Helmy St.	1	16	3,861	3,228	5,554	148	315	593	1,267	230	26	7	352	119	15,700
	2	16	7,373	4,801	4,247	40	332	524	1,310	239	18	26	569	201	19,680
	Total		11,234	8,029	9,801	188	647	1,117	2,577	469	44	33	921	320	35,380
	24 Hours		13,488	9,873	11,663	209	731	1,206	3,011	585	59	49	1,084	369	42,328
	Percent		31.9	23.3	27.6	0.5	1.7	2.9	7.1	1.4	0.1	0.1	2.6	0.9	100.0
NW08 Ramsis St.	1	16	12,944	10,699	3,673	1,927	1,526	1,019	1,977	595	19	28	1,064	190	35,661
	2	16	15,449	10,990	5,836	1,569	2,501	2,759	1,933	623	27	24	942	224	42,877
	Total		28,393	21,689	9,509	3,496	4,027	3,778	3,910	1,218	46	52	2,006	414	78,538
	24 Hours		34,091	26,670	11,316	3,881	4,551	4,080	4,569	1,520	62	77	2,360	477	93,653
	Percent		36.4	28.5	12.1	4.1	4.9	4.4	4.9	1.6	0.1	0.1	2.5	0.5	100.0
NW09 Salah Salem Road	1	16	21,237	8,217	6,633	143	826	923	4,558	1,216	34	12	1,024	249	45,072
	2	16	23,590	8,489	6,301	188	966	881	3,643	1,021	37	32	627	152	45,927
	Total		44,827	16,706	12,934	331	1,792	1,804	8,201	2,237	71	44	1,651	401	90,999
	24 Hours		53,822	20,542	15,391	367	2,025	1,948	9,583	2,791	95	66	1,943	462	109,037
	Percent		49.4	18.8	14.1	0.3	1.9	1.8	8.8	2.6	0.1	0.1	1.8	0.4	100.0
NW10 Tereat El-Zomor Road	1	16	7,989	6,731	5,415	97	191	523	1,595	268	13	12	1,563	423	24,820
	2	16	5,744	4,203	5,618	10	139	234	884	196	14	2	931	198	18,173
	Total		13,733	10,934	11,033	107	330	757	2,479	464	27	14	2,494	621	42,993
	24 Hours		16,489	13,445	13,129	119	373	818	2,897	579	36	21	2,935	716	51,556
	Percent		32.0	26.1	25.5	0.2	0.7	1.6	5.6	1.1	0.1	0.0	5.7	1.4	100.0
NW11 Sudan St.	1	16	5,575	3,921	1,912	681	365	1,777	725	298	8	43	540	117	15,962
	2	16	7,322	5,594	1,865	151	339	2,069	1,083	339	15	2	631	70	19,480
	Total		12,897	9,515	3,777	832	704	3,846	1,808	637	23	45	1,171	187	35,442
	24 Hours		15,485	11,700	4,495	924	796	4,154	2,113	795	31	67	1,378	216	42,151
	Percent		36.7	27.8	10.7	2.2	1.9	9.9	5.0	1.9	0.1	0.2	3.3	0.5	100.0
Sub-Tot	Total		265,565	121,546	79,917	8,043	13,187	23,059	44,863	13,903	1,256	934	13,948	3,804	590,025
	24 Hours		318,856	149,457	95,101	8,928	14,901	24,904	52,425	17,346	1,687	1,391	16,412	4,386	705,795
	Percent		45.2	21.2	13.5	1.3	2.1	3.5	7.4	2.5	0.2	0.2	2.3	0.6	100.0

A3-6-3

Appendix 3.6-4: Summary of Traffic Count Data for Bridges in 2005 (Unit: PCU)

Site	Direction	Duration	Number of PCU's												
			Car		Bus				Truck				Motorcycle	Other	Total
			Car	Taxi	Shared Taxi	Mini	Public	Private	Pickup	2-Axle	3-Axle	> 3 Axle			
B01 Warraq	1	16	6,931	1,054	5,448	16	190	1,174	5,051	9,702	500	6,279	68	131	36,544
	2	16	6,311	830	4,374	160	60	1,538	4,901	6,780	423	4,485	58	110	30,030
	Total		13,242	1,884	9,822	176	250	2,712	9,952	16,482	923	10,764	126	241	66,574
	24 Hours		15,899	2,317	11,688	195	283	2,929	11,629	20,564	1,239	16,028	149	278	83,198
	Percent		19.1	2.8	14.0	0.2	0.3	3.5	14.0	24.7	1.5	19.3	0.2	0.3	100.0
B02 Rodh El-Farag	1	16	13,606	12,416	12,692	184	1,075	1,722	4,138	3,420	390	399	598	297	50,937
	2	16	10,457	9,774	10,830	956	3,358	2,974	5,027	3,750	625	432	357	416	48,956
	Total		24,063	22,190	23,522	1,140	4,433	4,696	9,165	7,170	1,015	831	955	713	99,892
	24 Hours		28,892	27,286	27,991	1,265	5,009	5,072	10,710	8,946	1,363	1,237	1,124	822	119,716
	Percent		24.1	22.8	23.4	1.1	4.2	4.2	8.9	7.5	1.1	1.0	0.9	0.7	100.0
B03 Imbaba	1	16	2,376	2,375	2,042	0	0	32	629	934	3	0	370	153	8,913
	2	16	2,777	3,050	7,109	4	0	64	987	358	0	0	371	184	14,903
	Total		5,153	5,425	9,150	4	0	96	1,616	1,292	3	0	741	337	23,817
	24 Hours		6,187	6,671	10,889	4	0	104	1,888	1,612	3	0	872	389	28,619
	Percent		21.6	23.3	38.0	0.0	0.0	0.4	6.6	5.6	0.0	0.0	3.0	1.4	100.0
B04 15th of May	1	16	21,460	12,955	11,606	2,198	545	2,320	988	154	33	3	535	126	52,922
	2	16	33,622	16,846	7,418	8,092	2,450	5,094	4,421	2,060	118	18	847	36	81,021
	Total		55,082	29,801	19,023	10,290	2,995	7,414	5,409	2,214	150	21	1,382	162	133,943
	24 Hours		66,135	36,644	22,637	11,422	3,384	8,007	6,321	2,762	201	31	1,626	187	159,359
	Percent		41.5	23.0	14.2	7.2	2.1	5.0	4.0	1.7	0.1	0.0	1.0	0.1	100.0
B05 6th of October	1	16	104,226	23,001	4,403	908	4,075	6,620	5,084	3,530	30	60	765	232	152,933
	2	16	74,511	21,803	12,662	1,384	2,888	3,032	3,876	928	38	72	718	139	122,050
	Total		178,737	44,804	17,064	2,292	6,963	9,652	8,960	4,458	68	132	1,483	371	274,983
	24 Hours		214,604	55,093	20,306	2,544	7,868	10,424	10,470	5,562	91	197	1,745	428	329,331
	Percent		65.2	16.7	6.2	0.8	2.4	3.2	3.2	1.7	0.0	0.1	0.5	0.1	100.0
B06 Galaa	1	16	13,648	9,648	2,000	1,068	2,888	1,202	984	128	15	30	340	55	32,005
	2	16	12,161	9,145	1,805	1,464	3,563	1,036	643	300	3	12	249	96	30,476
	Total		25,809	18,793	3,804	2,532	6,450	2,238	1,627	428	18	42	589	151	62,481
	24 Hours		30,988	23,109	4,527	2,811	7,289	2,417	1,901	534	24	63	694	174	74,528
	Percent		41.6	31.0	6.1	3.8	9.8	3.2	2.6	0.7	0.0	0.1	0.9	0.2	100.0
B07 Gamah	1	16	17,420	9,842	2,268	696	2,575	1,276	1,194	54	0	15	231	92	35,663
	2	16	17,585	12,163	4,338	1,566	3,020	1,496	1,259	634	5	18	322	245	42,651
	Total		35,005	22,005	6,606	2,262	5,595	2,772	2,453	688	5	33	553	337	78,314
	24 Hours		42,029	27,058	7,861	2,511	6,322	2,994	2,866	858	7	49	650	389	93,595
	Percent		44.9	28.9	8.4	2.7	6.8	3.2	3.1	0.9	0.0	0.1	0.7	0.4	100.0
B08 Giza	1	16	16,529	10,366	7,266	248	1,390	2,342	2,816	2,140	18	42	433	399	43,989
	2	16	18,754	12,666	8,001	862	1,728	1,954	2,010	1,038	158	105	423	455	48,153
	Total		35,283	23,032	15,267	1,110	3,118	4,296	4,826	3,178	175	147	856	854	92,142
	24 Hours		42,363	28,321	18,168	1,232	3,523	4,640	5,639	3,965	235	219	1,007	985	110,297
	Percent		38.4	25.7	16.5	1.1	3.2	4.2	5.1	3.6	0.2	0.2	0.9	0.9	100.0
B09 Moneeb	1	16	26,222	5,798	4,281	546	313	2,328	3,259	3,848	1,898	2,085	162	142	50,881
	2	16	35,595	7,724	6,516	72	288	3,154	5,695	6,042	1,328	2,223	209	347	69,192
	Total		61,817	13,522	10,797	618	600	5,482	8,954	9,890	3,225	4,308	371	489	120,073
	24 Hours		74,222	16,627	12,848	686	678	5,921	10,463	12,339	4,332	6,415	437	564	145,532
	Percent		51.0	11.4	8.8	0.5	0.5	4.1	7.2	8.5	3.0	4.4	0.3	0.4	100.0
B10 Marazeeq	1	16	1,292	61	1,686	34	160	842	1,747	1,992	120	678	16	245	8,873
	2	16	1,207	44	1,685	6	28	978	1,716	1,868	110	972	26	233	8,872
	Total		2,499	105	3,371	40	188	1,820	3,463	3,860	230	1,650	41	478	17,744
	24 Hours		3,000	129	4,011	44	212	1,966	4,047	4,816	309	2,457	49	551	21,591
	Percent		13.9	0.6	18.6	0.2	1.0	9.1	18.7	22.3	1.4	11.4	0.2	2.6	100.0
Sub-Tot	Total		436,690	181,561	118,425	20,464	30,590	41,178	56,425	49,660	5,810	17,928	7,098	4,133	969,962
	24 Hours		524,320	223,254	140,926	22,715	34,567	44,472	65,936	61,959	7,804	26,695	8,352	4,766	1,165,766
	Percent		45.0	19.2	12.1	1.9	3.0	3.8	5.7	5.3	0.7	2.3	0.7	0.4	100.0

Appendix 3.6-5: Summary of Traffic Count Data for Some Major Arterials in 2005 (Unit: PCU)

A3-6-5

Site	Direction	Duration	Number of PCU's												
			Car	Taxi	Bus				Truck				Motorcycle	Other	Total
					Shared Taxi	Mini	Public	Private	Pickup	2-Axle	3-Axle	> 3 Axle			
A18 26th of July Corridor	1	16	33,592	2,582	6,696	74	600	2,650	485	338	33	6	47	44	47,147
	2	16	23,884	2,718	5,870	1,316	925	1,678	2,090	1,026	225	138	70	10	39,949
	Total		57,476	5,300	12,566	1,390	1,525	4,328	2,575	1,364	258	144	117	54	87,096
	24 Hours		69,010	6,517	14,953	1,543	1,723	4,674	3,009	1,702	346	214	138	62	103,891
	Percent		66.4	6.3	14.4	1.5	1.7	4.5	2.9	1.6	0.3	0.2	0.1	0.1	100.0
A21 Suez Road	1	16	12,823	370	1,697	28	198	1,644	1,044	660	78	519	24	196	19,279
	2	16	14,208	378	1,437	18	260	2,164	1,094	860	128	411	27	248	21,233
	Total		27,031	748	3,134	46	458	3,808	2,138	1,520	205	930	51	444	40,512
	24 Hours		32,455	920	3,729	51	517	4,113	2,498	1,896	275	1,385	60	512	48,411
	Percent		67.0	1.9	7.7	0.1	1.1	8.5	5.2	3.9	0.6	2.9	0.1	1.1	100.0
A35 Alex Agriculture Road	1	16	12,080	1,357	18,006	4,000	2,618	1,648	6,353	10,436	1,458	6,129	116	100	64,300
	2	16	12,977	1,503	16,896	32	2,178	7,362	6,634	9,732	2,305	5,475	160	77	65,331
	Total		25,057	2,860	34,902	4,032	4,795	9,010	12,987	20,168	3,763	11,604	276	177	129,630
	24 Hours		30,085	3,517	41,533	4,476	5,418	9,731	15,176	25,163	5,054	17,279	324	204	157,960
	Percent		19.0	2.2	26.3	2.8	3.4	6.2	9.6	15.9	3.2	10.9	0.2	0.1	100.0
A36 Ismailia Agriculture Road	1	16	2,799	654	4,031	40	1,333	640	3,506	4,390	85	1,251	113	117	18,958
	2	16	2,695	1,011	3,669	372	1,305	434	3,283	3,898	393	1,206	159	195	18,620
	Total		5,494	1,665	7,700	412	2,638	1,074	6,789	8,288	478	2,457	272	312	37,577
	24 Hours		6,596	2,047	9,162	457	2,980	1,160	7,933	10,341	641	3,659	320	360	45,657
	Percent		14.4	4.5	20.1	1.0	6.5	2.5	17.4	22.6	1.4	8.0	0.7	0.8	100.0
A39 Ismailia Desert Road	1	16	18,621	1,355	6,993	12	2,895	3,256	5,371	8,568	1,465	2,949	25	230	51,740
	2	16	16,211	1,451	8,253	10	2,055	2,116	6,899	13,094	1,610	3,675	16	161	55,551
	Total		34,832	2,806	15,246	22	4,950	5,372	12,270	21,662	3,075	6,624	41	391	107,291
	24 Hours		41,822	3,450	18,143	24	5,594	5,802	14,338	27,027	4,130	9,863	49	451	130,693
	Percent		32.0	2.6	13.9	0.0	4.3	4.4	11.0	20.7	3.2	7.5	0.0	0.3	100.0
A42 Autostrade	1	16	6,042	1,063	3,485	6	78	410	1,535	3,226	705	3,657	15	84	20,305
	2	16	6,859	1,050	4,422	8	133	836	1,845	6,030	955	4,164	28	86	26,416
	Total		12,901	2,113	7,907	14	210	1,246	3,380	9,256	1,660	7,821	43	170	46,721
	24 Hours		15,490	2,598	9,409	16	237	1,346	3,950	11,548	2,230	11,646	51	196	58,716
	Percent		26.4	4.4	16.0	0.0	0.4	2.3	6.7	19.7	3.8	19.8	0.1	0.3	100.0
AC20 Nasr Road	1	16	49,272	16,673	17,906	2,716	6,513	4,350	5,923	2,830	333	603	225	301	107,643
	2	16	34,680	15,531	11,772	5,138	11,688	5,492	4,856	4,430	203	264	300	842	95,195
	Total		83,952	32,204	29,678	7,854	18,200	9,842	10,779	7,260	535	867	525	1,143	202,838
	24 Hours		100,799	39,599	35,316	8,718	20,566	10,629	12,596	9,058	719	1,291	617	1,318	241,226
	Percent		41.8	16.4	14.6	3.6	8.5	4.4	5.2	3.8	0.3	0.5	0.3	0.5	100.0
Sub-Tot	Total		246,743	47,696	111,131	13,770	32,775	34,680	50,918	69,518	9,973	30,447	1,325	2,691	651,666
	24 Hours		296,257	58,649	132,245	15,285	37,036	37,454	59,500	86,735	13,395	45,336	1,559	3,103	786,554
	Percent		37.7	7.5	16.8	1.9	4.7	4.8	7.6	11.0	1.7	5.8	0.2	0.4	100.0

Appendix 3.6-6: Summary of Traffic Count Data for New Sites in 2005 (Unit: PCU)

Site	Direction	Duration	Number of PCU's											Total	
			Car		Bus				Truck				Motorcycle		Other
			Car	Taxi	Shared Taxi	Mini	Public	Private	Pickup	2-Axle	3-Axle	> 3 Axle			
NW01	1	16	12,503	6,651	6,713	580	1,983	2,030	4,660	3,814	610	540	192	258	40,533
	2	16	15,289	4,633	6,681	74	2,600	3,184	4,021	3,220	370	558	191	309	41,130
	Total		27,792	11,284	13,394	654	4,583	5,214	8,681	7,034	980	1,098	382	567	81,662
	24 Hours		33,369	13,875	15,938	726	5,178	5,631	10,144	8,776	1,316	1,635	450	654	97,693
	Percent		34.2	14.2	16.3	0.7	5.3	5.8	10.4	9.0	1.3	1.7	0.5	0.7	100.0
NW02	1	16	19,260	2,424	1,986	222	428	2,748	1,715	1,172	155	201	92	153	30,555
	2	16	12,791	3,484	3,819	1,530	960	1,940	1,800	1,494	773	309	89	178	29,167
	Total		32,051	5,908	5,805	1,752	1,388	4,688	3,515	2,666	928	510	181	331	59,722
	24 Hours		38,483	7,265	6,908	1,945	1,568	5,063	4,107	3,326	1,246	759	213	382	71,264
	Percent		54.0	10.2	9.7	2.7	2.2	7.1	5.8	4.7	1.7	1.1	0.3	0.5	100.0
NW03	1	16	11,615	6,938	2,469	868	1,968	1,394	1,402	330	153	69	213	131	27,549
	2	16	13,616	6,949	1,638	210	1,240	1,040	1,237	204	15	45	229	88	26,511
	Total		25,231	13,887	4,107	1,078	3,208	2,434	2,639	534	168	114	442	219	54,060
	24 Hours		30,294	17,076	4,887	1,197	3,624	2,629	3,084	666	225	170	520	253	64,624
	Percent		46.9	26.4	7.6	1.9	5.6	4.1	4.8	1.0	0.3	0.3	0.8	0.4	100.0
NW04	1	16	3,394	3,793	2,478	22	1,020	1,328	1,251	784	70	54	162	112	14,468
	2	16	3,374	2,784	1,950	10	795	1,232	1,053	620	70	72	131	142	12,233
	Total		6,768	6,577	4,428	32	1,815	2,560	2,304	1,404	140	126	293	254	26,701
	24 Hours		8,126	8,087	5,269	36	2,051	2,765	2,692	1,752	188	188	345	293	31,791
	Percent		25.6	25.4	16.6	0.1	6.5	8.7	8.5	5.5	0.6	0.6	1.1	0.9	100.0
NW05	1	16	27,070	7,816	11,990	1,758	2,038	5,916	2,498	954	33	9	272	187	60,539
	2	16	0	0	0	0	0	0	0	0	0	0	0	0	
	Total		27,070	7,816	11,990	1,758	2,038	5,916	2,498	954	33	9	272	187	60,539
	24 Hours		32,502	9,611	14,268	1,951	2,302	6,389	2,919	1,190	44	13	320	216	71,725
	Percent		45.3	13.4	19.9	2.7	3.2	8.9	4.1	1.7	0.1	0.0	0.4	0.3	100.0
NW06	1	16	18,382	4,706	2,856	454	555	1,292	2,449	1,892	168	183	149	162	33,248
	2	16	17,187	4,495	6,716	450	633	1,410	3,802	3,272	198	198	163	141	38,664
	Total		35,569	9,201	9,572	904	1,188	2,702	6,251	5,164	365	381	313	303	71,912
	24 Hours		42,707	11,314	11,390	1,003	1,342	2,918	7,305	6,443	490	567	368	349	86,196
	Percent		49.5	13.1	13.2	1.2	1.6	3.4	8.5	7.5	0.6	0.7	0.4	0.4	100.0
NW07	1	16	3,861	3,228	8,331	296	788	1,186	1,267	460	65	21	116	119	19,738
	2	16	7,373	4,801	6,371	80	830	1,048	1,310	478	45	78	188	201	22,802
	Total		11,234	8,029	14,702	376	1,618	2,234	2,577	938	110	99	304	320	42,540
	24 Hours		13,488	9,873	17,495	417	1,828	2,413	3,011	1,170	148	147	358	369	50,717
	Percent		26.6	19.5	34.5	0.8	3.6	4.8	5.9	2.3	0.3	0.3	0.7	0.7	100.0
NW08	1	16	12,944	10,699	5,510	3,854	3,815	2,038	1,977	1,190	48	84	351	190	42,699
	2	16	15,449	10,990	8,754	3,138	6,253	5,518	1,933	1,246	68	72	311	224	53,955
	Total		28,393	21,689	14,264	6,992	10,068	7,556	3,910	2,436	115	156	662	414	96,654
	24 Hours		34,091	26,670	16,974	7,761	11,376	8,160	4,569	3,039	154	232	779	477	114,283
	Percent		29.8	23.3	14.9	6.8	10.0	7.1	4.0	2.7	0.1	0.2	0.7	0.4	100.0
NW09	1	16	21,237	8,217	9,950	286	2,065	1,846	4,558	2,432	85	36	338	249	51,298
	2	16	23,590	8,489	9,452	376	2,415	1,762	3,643	2,042	93	96	207	152	52,316
	Total		44,827	16,706	19,401	662	4,480	3,608	8,201	4,474	178	132	545	401	103,614
	24 Hours		53,822	20,542	23,087	735	5,062	3,897	9,583	5,582	238	197	641	462	123,850
	Percent		43.5	16.6	18.6	0.6	4.1	3.1	7.7	4.5	0.2	0.2	0.5	0.4	100.0
NW10	1	16	7,989	6,731	8,123	194	478	1,046	1,595	536	33	36	516	423	27,698
	2	16	5,744	4,203	8,427	20	348	468	884	392	35	6	307	198	21,032
	Total		13,733	10,934	16,550	214	825	1,514	2,479	928	68	42	823	621	48,730
	24 Hours		16,489	13,445	19,694	238	932	1,635	2,897	1,158	91	63	968	716	58,325
	Percent		28.3	23.1	33.8	0.4	1.6	2.8	5.0	2.0	0.2	0.1	1.7	1.2	100.0
NW11	1	16	5,575	3,921	2,868	1,362	913	3,554	725	596	20	129	178	117	19,958
	2	16	7,322	5,594	2,798	302	848	4,138	1,083	678	38	6	208	70	23,084
	Total		12,897	9,515	5,666	1,664	1,760	7,692	1,808	1,274	58	135	386	187	43,041
	24 Hours		15,485	11,700	6,742	1,847	1,989	8,307	2,113	1,590	77	201	455	216	50,721
	Percent		30.5	23.1	13.3	3.6	3.9	16.4	4.2	3.1	0.2	0.4	0.9	0.4	100.0
Sub-Tot	Total		265,565	121,546	119,876	16,086	32,968	46,118	44,863	27,806	3,140	2,802	4,603	3,804	689,176
	24 Hours		318,856	149,457	142,652	17,855	37,253	49,807	52,425	34,693	4,218	4,172	5,416	4,386	821,191
	Percent		38.8	18.2	17.4	2.2	4.5	6.1	6.4	4.2	0.5	0.5	0.7	0.5	100.0

Appendix 3.6-7: Summary of Traffic Count Data for Bridges in 2001 (Unit: Vehicles)

Site	Direction	Duration	Number of Vehicles												
					Bus				Truck						Total
			Car	Taxi	Shared Taxi	Mini	Public	Private	Pickup	2-Axle	3-Axle	> 3 Axle	Motorcycle	Other	
B01 Warraq	1	24	7,196	750	830	670	5	352	4,784	5,796	367	2,113	231	79	23,173
	2	24	7,466	692	730	576	12	301	3,974	5,160	446	1,806	157	86	21,406
	Total		14,662	1,442	1,560	1,246	17	653	8,758	10,956	813	3,919	388	165	44,579
	24 Hours		14,662	1,442	1,560	1,246	17	653	8,758	10,956	813	3,919	388	165	44,579
	Percent		32.9	3.2	3.5	2.8	0.0	1.5	19.6	24.6	1.8	8.8	0.9	0.4	100.0
B02 Rodh El-Farag	1	24	19,099	18,050	7,958	1,065	581	828	5,661	3,738	97	187	3,076	305	60,645
	2	24	12,297	10,360	4,754	666	437	479	3,995	2,390	83	94	2,045	158	37,758
	Total		31,396	28,410	12,712	1,731	1,018	1,307	9,656	6,128	180	281	5,121	463	98,403
	24 Hours		31,396	28,410	12,712	1,731	1,018	1,307	9,656	6,128	180	281	5,121	463	98,403
	Percent		31.9	28.9	12.9	1.8	1.0	1.3	9.8	6.2	0.2	0.3	5.2	0.5	100.0
B03 Imbaba	1	24	2,647	3,130	1,960	62	0	10	747	174	11	0	1,069	186	9,996
	2	24	2,458	3,175	4,274	50	0	44	856	176	0	0	1,222	201	12,456
	Total		5,105	6,305	6,234	112	0	54	1,603	350	11	0	2,291	387	22,452
	24 Hours		5,105	6,305	6,234	112	0	54	1,603	350	11	0	2,291	387	22,452
	Percent		22.7	28.1	27.8	0.5	0.0	0.2	7.1	1.6	0.0	0.0	10.2	1.7	100.0
B04 15th of May	1	24	34,611	20,567	5,931	1,770	121	702	2,480	493	18	27	2,491	239	69,450
	2	24	31,213	21,494	4,724	1,738	145	536	2,731	600	48	17	2,359	242	65,847
	Total		65,824	42,061	10,655	3,508	266	1,238	5,211	1,093	66	44	4,850	481	135,297
	24 Hours		65,824	42,061	10,655	3,508	266	1,238	5,211	1,093	66	44	4,850	481	135,297
	Percent		48.7	31.1	7.9	2.6	0.2	0.9	3.9	0.8	0.0	0.0	3.6	0.4	100.0
B05 6th of October	1	24	79,972	21,634	4,179	1,518	1,500	1,126	3,197	1,334	171	7	2,239	619	117,496
	2	24	87,764	26,876	3,776	1,807	1,198	1,043	3,884	1,206	6	1	2,509	373	130,443
	Total		167,736	48,510	7,955	3,325	2,698	2,169	7,081	2,540	177	8	4,748	992	247,939
	24 Hours		167,736	48,510	7,955	3,325	2,698	2,169	7,081	2,540	177	8	4,748	992	247,939
	Percent		67.7	19.6	3.2	1.3	1.1	0.9	2.9	1.0	0.1	0.0	1.9	0.4	100.0
B06 Galaa	1	24	16,837	12,647	1,282	643	1,497	447	671	367	43	0	1,236	124	35,794
	2	24	12,839	9,829	1,200	778	1,577	203	513	239	3	0	1,304	113	28,598
	Total		29,676	22,476	2,482	1,421	3,074	650	1,184	606	46	0	2,540	237	64,392
	24 Hours		29,676	22,476	2,482	1,421	3,074	650	1,184	606	46	0	2,540	237	64,392
	Percent		46.1	34.9	3.9	2.2	4.8	1.0	1.8	0.9	0.1	0.0	3.9	0.4	100.0
B07 Gamah	1	24	17,462	10,458	1,050	519	1,542	149	1,293	437	15	24	1,372	157	34,478
	2	24	20,604	11,890	1,116	575	1,582	153	1,850	557	9	55	1,466	164	40,021
	Total		38,066	22,348	2,166	1,094	3,124	302	3,143	994	24	79	2,838	321	74,499
	24 Hours		38,066	22,348	2,166	1,094	3,124	302	3,143	994	24	79	2,838	321	74,499
	Percent		51.1	30.0	2.9	1.5	4.2	0.4	4.2	1.3	0.0	0.1	3.8	0.4	100.0
B08 Giza	1	24	22,218	11,220	4,982	874	686	476	3,097	900	34	81	1,314	480	46,362
	2	24	20,950	13,500	5,093	997	844	570	2,296	886	63	56	1,700	565	47,520
	Total		43,168	24,720	10,075	1,871	1,530	1,046	5,393	1,786	97	137	3,014	1,045	93,882
	24 Hours		43,168	24,720	10,075	1,871	1,530	1,046	5,393	1,786	97	137	3,014	1,045	93,882
	Percent		46.0	26.3	10.7	2.0	1.6	1.1	5.7	1.9	0.1	0.1	3.2	1.1	100.0
B09 Moneeb	1	24	16,768	2,905	739	720	105	340	3,920	2,402	110	499	561	318	29,387
	2	24	25,507	4,167	653	722	65	383	4,494	1,812	109	626	516	349	39,403
	Total		42,275	7,072	1,392	1,442	170	723	8,414	4,214	219	1,125	1,077	667	68,790
	24 Hours		42,275	7,072	1,392	1,442	170	723	8,414	4,214	219	1,125	1,077	667	68,790
	Percent		61.5	10.3	2.0	2.1	0.2	1.1	12.2	6.1	0.3	1.6	1.6	1.0	100.0
B10 Marazeeq	1	24	1,380	165	921	100	11	448	1,449	1,434	254	509	157	256	7,084
	2	24	1,493	142	1,112	83	7	450	1,576	1,854	179	501	119	215	7,731
	Total		2,873	307	2,033	183	18	898	3,025	3,288	433	1,010	276	471	14,815
	24 Hours		2,873	307	2,033	183	18	898	3,025	3,288	433	1,010	276	471	14,815
	Percent		19.4	2.1	13.7	1.2	0.1	6.1	20.4	22.2	2.9	6.8	1.9	3.2	100.0
Sub-Tot	Total		440,781	203,651	57,264	15,933	11,915	9,040	53,468	31,955	2,066	6,603	27,143	5,229	865,048
	24 Hours		440,781	203,651	57,264	15,933	11,915	9,040	53,468	31,955	2,066	6,603	27,143	5,229	865,048
	Percent		51.0	23.5	6.6	1.8	1.4	1.0	6.2	3.7	0.2	0.8	3.1	0.6	100.0

A3-6-7

Appendix 3.6-8: Summary of Traffic Count Data for Some Major Arterials in 2001 (Unit: Vehicles)

Site	Direction	Duration	Number of Vehicles												
					Bus				Truck						Total
			Car	Taxi	Shared Taxi	Mini	Public	Private	Pickup	2-Axle	3-Axle	> 3 Axle	Motorcycle	Other	
A18 26th of July Corridor	1	16	33,592	2,582	1,325	37	4,464	240	485	169	13	2	143	44	43,096
	2	16	23,884	2,718	839	658	3,913	370	2,090	513	90	46	212	10	35,343
	Total		57,476	5,300	2,164	695	8,377	610	2,575	682	103	48	355	54	78,439
	24 Hours		69,010	6,517	2,575	771	9,466	659	3,009	851	138	71	418	62	93,548
	Percent		73.8	7.0	2.8	0.8	10.1	0.7	3.2	0.9	0.1	0.1	0.4	0.1	100.0
A21 Suez Road	1	16	6,551	657	1,164	454	173	349	820	416	32	50	99	185	10,950
	2	16	6,068	656	1,102	431	226	442	946	418	26	41	106	198	10,660
	Total		12,619	1,313	2,266	885	399	791	1,766	834	58	91	205	383	21,610
	24 Hours		15,151	1,615	2,697	982	451	854	2,064	1,041	78	136	241	442	25,750
	Percent		58.8	6.3	10.5	3.8	1.8	3.3	8.0	4.0	0.3	0.5	0.9	1.7	100.0
A35 Alex Agriculture Road	1	16	12,049	4,250	5,430	2,389	687	1,439	7,071	7,398	424	3,557	651	220	45,565
	2	16	9,737	2,928	4,646	1,447	432	1,165	6,618	7,278	149	2,724	803	201	38,128
	Total		21,786	7,178	10,076	3,836	1,119	2,604	13,689	14,676	573	6,281	1,454	421	83,693
	24 Hours		26,158	8,826	11,990	4,258	1,264	2,812	15,996	18,311	770	9,353	1,711	485	101,935
	Percent		25.7	8.7	11.8	4.2	1.2	2.8	15.7	18.0	0.8	9.2	1.7	0.5	100.0
A36 Ismailia Agriculture Road	1	16	1,835	790	1,956	170	64	190	2,166	1,450	70	186	371	134	9,382
	2	16	1,809	720	2,202	180	64	198	2,394	1,369	84	247	422	149	9,838
	Total		3,644	1,510	4,158	350	128	388	4,560	2,819	154	433	793	283	19,220
	24 Hours		4,375	1,857	4,948	389	145	419	5,329	3,517	207	645	933	326	23,089
	Percent		18.9	8.0	21.4	1.7	0.6	1.8	23.1	15.2	0.9	2.8	4.0	1.4	100.0
A39 Ismailia Desert Road	1	16	15,026	1,375	2,621	2,223	400	1,300	6,474	5,775	312	1,832	282	212	37,832
	2	16	15,022	1,448	2,427	2,824	606	1,075	6,102	5,146	222	1,157	149	340	36,518
	Total		30,048	2,823	5,048	5,047	1,006	2,375	12,576	10,921	534	2,989	431	552	74,350
	24 Hours		36,078	3,471	6,007	5,602	1,137	2,565	14,696	13,626	717	4,451	507	637	89,493
	Percent		40.3	3.9	6.7	6.3	1.3	2.9	16.4	15.2	0.8	5.0	0.6	0.7	100.0
A42 Autostrade	1	16	6,629	818	1,315	453	14	235	2,322	2,133	308	653	266	377	15,523
	2	16	6,664	982	1,410	410	21	248	2,221	2,420	328	780	250	348	16,082
	Total		13,293	1,800	2,725	863	35	483	4,543	4,553	636	1,433	516	725	31,605
	24 Hours		15,961	2,213	3,243	958	40	522	5,309	5,681	854	2,134	607	836	38,356
	Percent		41.6	5.8	8.5	2.5	0.1	1.4	13.8	14.8	2.2	5.6	1.6	2.2	100.0
AC20 Nasr Road	1	16	49,936	10,110	6,215	1,419	1,582	867	3,474	1,540	62	56	909	314	76,484
	2	16	52,863	13,303	5,809	1,871	1,342	983	4,733	1,677	103	82	1,281	546	84,593
	Total		102,799	23,413	12,024	3,290	2,924	1,850	8,207	3,217	165	138	2,190	860	161,077
	24 Hours		123,428	28,789	14,309	3,652	3,304	1,998	9,590	4,014	222	205	2,577	992	193,079
	Percent		63.9	14.9	7.4	1.9	1.7	1.0	5.0	2.1	0.1	0.1	1.3	0.5	100.0
Sub-Tot	Total		241,665	43,337	38,461	14,966	13,988	9,101	47,916	37,702	2,223	11,413	5,944	3,278	469,994
	24 Hours		290,160	53,289	45,769	16,612	15,806	9,829	55,992	47,040	2,986	16,994	6,994	3,780	565,251
	Percent		51.3	9.4	8.1	2.9	2.8	1.7	9.9	8.3	0.5	3.0	1.2	0.7	100.0

A3-6-8

Appendix 3.6-9: Summary of Traffic Count Data for Bridges in 2001 (Unit: PCU)

Site	Direction	Duration	Number of PCU's												
			Car		Bus				Truck				Motorcycle	Other	Total
			Car	Taxi	Shared Taxi	Mini	Public	Private	Pickup	2-Axle	3-Axle	> 3 Axle			
B01 Warraq	1	24	7,196	750	1,245	1,340	13	704	4,784	11,592	918	6,339	76	79	35,035
	2	24	7,466	692	1,095	1,152	30	602	3,974	10,320	1,115	5,418	52	86	32,002
	Total		14,662	1,442	2,340	2,492	43	1,306	8,758	21,912	2,033	11,757	128	165	67,037
	24 Hours		14,662	1,442	2,340	2,492	43	1,306	8,758	21,912	2,033	11,757	128	165	67,037
	Percent		21.9	2.2	3.5	3.7	0.1	1.9	13.1	32.7	3.0	17.5	0.2	0.2	100.0
B02 Rodh El-Farag	1	24	19,099	18,050	11,937	2,130	1,453	1,656	5,661	7,476	243	561	1,015	305	69,585
	2	24	12,297	10,360	7,131	1,332	1,093	958	3,995	4,780	208	282	675	158	43,268
	Total		31,396	28,410	19,068	3,462	2,545	2,614	9,656	12,256	450	843	1,690	463	112,853
	24 Hours		31,396	28,410	19,068	3,462	2,545	2,614	9,656	12,256	450	843	1,690	463	112,853
	Percent		27.8	25.2	16.9	3.1	2.3	2.3	8.6	10.9	0.4	0.7	1.5	0.4	100.0
B03 Imbaba	1	24	2,647	3,130	2,940	124	0	20	747	3,940	28	0	353	186	10,522
	2	24	2,458	3,175	6,411	100	0	88	856	352	0	0	403	201	14,044
	Total		5,105	6,305	9,351	224	0	108	1,603	700	28	0	756	387	24,567
	24 Hours		5,105	6,305	9,351	224	0	108	1,603	700	28	0	756	387	24,567
	Percent		20.8	25.7	38.1	0.9	0.0	0.4	6.5	2.8	0.1	0.0	3.1	1.6	100.0
B04 15th of May	1	24	34,611	20,567	8,897	3,540	303	1,404	2,480	986	45	81	822	239	73,974
	2	24	31,213	21,494	7,086	3,476	363	1,072	2,731	1,200	120	51	778	242	69,826
	Total		65,824	42,061	15,983	7,016	665	2,476	5,211	2,186	165	132	1,601	481	143,800
	24 Hours		65,824	42,061	15,983	7,016	665	2,476	5,211	2,186	165	132	1,601	481	143,800
	Percent		45.8	29.2	11.1	4.9	0.5	1.7	3.6	1.5	0.1	0.1	1.1	0.3	100.0
B05 6th of October	1	24	79,972	21,634	6,269	3,036	3,750	2,252	3,197	2,668	428	21	739	619	124,584
	2	24	87,764	26,876	5,664	3,614	2,995	2,086	3,884	2,412	15	3	828	373	136,514
	Total		167,736	48,510	11,933	6,650	6,745	4,338	7,081	5,080	443	24	1,567	992	261,098
	24 Hours		167,736	48,510	11,933	6,650	6,745	4,338	7,081	5,080	443	24	1,567	992	261,098
	Percent		64.2	18.6	4.6	2.5	2.6	1.7	2.7	1.9	0.2	0.0	0.6	0.4	100.0
B06 Galaa	1	24	16,837	12,647	1,923	1,286	3,743	894	671	734	108	0	408	124	39,374
	2	24	12,839	9,829	1,800	1,556	3,943	406	513	478	8	0	430	113	31,914
	Total		29,676	22,476	3,723	2,842	7,685	1,300	1,184	1,212	115	0	838	237	71,288
	24 Hours		29,676	22,476	3,723	2,842	7,685	1,300	1,184	1,212	115	0	838	237	71,288
	Percent		41.6	31.5	5.2	4.0	10.8	1.8	1.7	1.7	0.2	0.0	1.2	0.3	100.0
B07 Gamah	1	24	17,462	10,458	1,575	1,038	3,855	298	1,293	874	38	72	453	157	37,572
	2	24	20,604	11,890	1,674	1,150	3,955	306	1,850	1,114	23	165	484	164	43,378
	Total		38,066	22,348	3,249	2,188	7,810	604	3,143	1,988	60	237	937	321	80,951
	24 Hours		38,066	22,348	3,249	2,188	7,810	604	3,143	1,988	60	237	937	321	80,951
	Percent		47.0	27.6	4.0	2.7	9.6	0.7	3.9	2.5	0.1	0.3	1.2	0.4	100.0
B08 Giza	1	24	22,218	11,220	7,473	1,748	1,715	952	3,097	1,800	85	243	434	480	51,465
	2	24	20,950	13,500	7,640	1,994	2,110	1,140	2,296	1,772	158	168	561	565	52,853
	Total		43,168	24,720	15,113	3,742	3,825	2,092	5,393	3,572	243	411	995	1,045	104,318
	24 Hours		43,168	24,720	15,113	3,742	3,825	2,092	5,393	3,572	243	411	995	1,045	104,318
	Percent		41.4	23.7	14.5	3.6	3.7	2.0	5.2	3.4	0.2	0.4	1.0	1.0	100.0
B09 Moneeb	1	24	16,768	2,905	1,109	1,440	263	680	3,920	4,804	275	1,497	185	318	34,163
	2	24	25,507	4,167	980	1,444	163	766	4,494	3,624	273	1,878	170	349	43,814
	Total		42,275	7,072	2,088	2,884	425	1,446	8,414	8,428	548	3,375	355	667	77,977
	24 Hours		42,275	7,072	2,088	2,884	425	1,446	8,414	8,428	548	3,375	355	667	77,977
	Percent		54.2	9.1	2.7	3.7	0.5	1.9	10.8	10.8	0.7	4.3	0.5	0.9	100.0
B10 Marazeeq	1	24	1,380	165	1,382	200	28	896	1,449	2,868	635	1,527	52	256	10,837
	2	24	1,493	142	1,668	166	18	900	1,576	3,708	448	1,503	39	215	11,875
	Total		2,873	307	3,050	366	45	1,796	3,025	6,576	1,083	3,030	91	471	22,712
	24 Hours		2,873	307	3,050	366	45	1,796	3,025	6,576	1,083	3,030	91	471	22,712
	Percent		12.6	1.4	13.4	1.6	0.2	7.9	13.3	29.0	4.8	13.3	0.4	2.1	100.0
Sub-Tot	Total		440,781	203,651	85,896	31,866	29,788	18,080	53,468	63,910	5,165	19,809	8,957	5,229	966,600
	24 Hours		440,781	203,651	85,896	31,866	29,788	18,080	53,468	63,910	5,165	19,809	8,957	5,229	966,600
	Percent		45.6	21.1	8.9	3.3	3.1	1.9	5.5	6.6	0.5	2.0	0.9	0.5	100.0

Appendix 3.6-10: Summary of Traffic Count Data for Some Major Arterials in 2001 (Unit: PCU)

Site	Direction	Duration	Number of PCU's												
			Car	Taxi	Bus				Truck				Motorcycle	Other	Total
					Shared Taxi	Mini	Public	Private	Pickup	2-Axle	3-Axle	> 3 Axle			
A18 26th of July Corridor	1	24	33,592	2,582	1,988	74	11,160	480	485	338	33	6	47	44	50,828
	2	24	23,884	2,718	1,259	1,316	9,783	740	2,090	1,026	225	138	70	10	43,258
	Total		57,476	5,300	3,246	1,390	20,943	1,220	2,575	1,364	258	144	117	54	94,086
	24 Hours		69,010	6,517	3,863	1,543	23,665	1,318	3,009	1,702	346	214	138	62	111,386
	Percent		62.0	5.9	3.5	1.4	21.2	1.2	2.7	1.5	0.3	0.2	0.1	0.1	100.0
A21 Suez Road	1	24	6,551	657	1,746	908	433	698	820	832	80	150	33	185	13,092
	2	24	6,068	656	1,653	862	565	884	946	836	65	123	35	198	12,891
	Total		12,619	1,313	3,399	1,770	998	1,582	1,766	1,668	145	273	68	383	25,983
	24 Hours		15,151	1,615	4,045	1,965	1,127	1,709	2,064	2,081	195	407	80	442	30,878
	Percent		49.1	5.2	13.1	6.4	3.7	5.5	6.7	6.7	0.6	1.3	0.3	1.4	100.0
A35 Alex Agriculture Road	1	16	12,049	4,250	8,145	4,778	1,718	2,878	7,071	14,796	1,060	10,671	215	220	67,850
	2	16	9,737	2,928	6,969	2,894	1,080	2,330	6,618	14,556	373	8,172	265	201	56,122
	Total		21,786	7,178	15,114	7,672	2,798	5,208	13,689	29,352	1,433	18,843	480	421	123,973
	24 Hours		26,158	8,826	17,986	8,516	3,161	5,625	15,996	36,622	1,924	28,058	565	485	153,921
	Percent		17.0	5.7	11.7	5.5	2.1	3.7	10.4	23.8	1.3	18.2	0.4	0.3	100.0
A36 Ismailia Agriculture Road	1	16	1,835	790	2,934	340	160	380	2,166	2,900	175	558	122	134	12,494
	2	16	1,809	720	3,303	360	160	396	2,394	2,738	210	741	139	149	13,119
	Total		3,644	1,510	6,237	700	320	776	4,560	5,638	385	1,299	262	283	25,614
	24 Hours		4,375	1,857	7,422	777	362	838	5,329	7,034	517	1,934	308	326	31,079
	Percent		14.1	6.0	23.9	2.5	1.2	2.7	17.1	22.6	1.7	6.2	1.0	1.0	100.0
A39 Ismailia Desert Road	1	16	15,026	1,375	3,932	4,446	1,000	2,600	6,474	11,550	780	5,496	93	212	52,984
	2	16	15,022	1,448	3,641	5,648	1,515	2,150	6,102	10,292	555	3,471	49	340	50,233
	Total		30,048	2,823	7,572	10,094	2,515	4,750	12,576	21,842	1,335	8,967	142	552	103,216
	24 Hours		36,078	3,471	9,011	11,204	2,842	5,130	14,696	27,252	1,793	13,352	167	637	125,632
	Percent		28.7	2.8	7.2	8.9	2.3	4.1	11.7	21.7	1.4	10.6	0.1	0.5	100.0
A42 Autostrade	1	16	6,629	818	1,973	906	35	470	2,322	4,266	770	1,959	88	377	20,612
	2	16	6,664	982	2,115	820	53	496	2,221	4,840	820	2,340	83	348	21,781
	Total		13,293	1,800	4,088	1,726	88	966	4,543	9,106	1,590	4,299	170	725	42,393
	24 Hours		15,961	2,213	4,864	1,916	99	1,043	5,309	11,361	2,136	6,401	200	836	52,339
	Percent		30.5	4.2	9.3	3.7	0.2	2.0	10.1	21.7	4.1	12.2	0.4	1.6	100.0
AC20 Nasr Road	1	16	49,936	10,110	9,323	2,838	3,955	1,734	3,474	3,080	155	168	300	314	85,386
	2	16	52,863	13,303	8,714	3,742	3,355	1,966	4,733	3,354	258	246	423	546	93,502
	Total		102,799	23,413	18,036	6,580	7,310	3,700	8,207	6,434	413	414	723	860	178,888
	24 Hours		123,428	28,789	21,463	7,304	8,260	3,996	9,590	8,028	554	616	850	992	213,870
	Percent		57.7	13.5	10.0	3.4	3.9	1.9	4.5	3.8	0.3	0.3	0.4	0.5	100.0
Sub-Tot	Total		241,665	43,337	57,692	29,932	34,970	18,202	47,916	75,404	5,558	34,239	1,962	3,278	594,154
	24 Hours		290,160	53,289	68,653	33,225	39,516	19,658	55,992	94,079	7,465	50,983	2,308	3,780	719,107
	Percent		40.4	7.4	9.5	4.6	5.5	2.7	7.8	13.1	1.0	7.1	0.3	0.5	100.0

A3-6-10

APPENDIX 3.7

RESULTS OF WILLINGNESS-TO-PAY SURVEY

Appendix 3.7 Crosstabulation of Toll Value with Other Variables within the Sample

Vehicle Type * Payment for 25% Reduction of Travel Time Crosstabulation

% within Vehicle Type

		Payment for 25% Reduction of Travel Time						Total
		1 LE/Trip	2 LE/Trip	3 LE/Trip	4 LE/Trip	5 LE/Trip	> 5 LE/Trip	
Vehicle Type	Passenger Car	62.6%	23.6%	5.8%	0.9%	4.9%	2.1%	100%
	Taxi (B/W)	37.9%	20.0%	10.5%	4.2%	14.7%	12.6%	100%
	Shared Taxi (Microbus)	95.2%	4.8%					100%
	Light Truck (Pickup)	78.8%	11.3%	5.0%	2.5%	1.3%	1.3%	100%
Total		64.3%	19.2%	5.9%	1.6%	5.5%	3.6%	100%

Vehicle Type * Payment for 50% Reduction of Travel Time Crosstabulation

% within Vehicle Type

		Payment for 50% Reduction of Travel Time						Total
		1 LE/Trip	2 LE/Trip	3 LE/Trip	4 LE/Trip	5 LE/Trip	> 5 LE/Trip	
Vehicle Type	Passenger Car	50.2%	29.9%	7.1%	2.7%	5.6%	4.4%	100%
	Taxi (B/W)	22.1%	25.0%	12.5%	2.9%	13.5%	24.0%	100%
	Shared Taxi (Microbus)	78.8%	18.3%	1.9%		1.0%		100%
	Light Truck (Pickup)	56.1%	27.2%	6.1%	2.6%	4.4%	3.5%	100%
Total		51.1%	27.4%	7.0%	2.4%	5.9%	6.3%	100%

Gender * Payment for 25% Reduction of Travel Time Crosstabulation

% within Gender

		Payment for 25% Reduction of Travel Time						Total
		1 LE/Trip	2 LE/Trip	3 LE/Trip	4 LE/Trip	5 LE/Trip	> 5 LE/Trip	
Gender	Male	66.7%	19.0%	4.3%	1.6%	5.1%	3.3%	100%
	Female	47.9%	20.5%	16.4%	1.4%	8.2%	5.5%	100%
Total		64.3%	19.2%	5.9%	1.6%	5.5%	3.6%	100%

Gender * Payment for 50% Reduction of Travel Time Crosstabulation

% within Gender

		Payment for 50% Reduction of Travel Time						Total
		1 LE/Trip	2 LE/Trip	3 LE/Trip	4 LE/Trip	5 LE/Trip	> 5 LE/Trip	
Gender	Male	53.2%	27.6%	6.8%	2.6%	4.5%	5.3%	100%
	Female	32.9%	25.6%	8.5%		18.3%	14.6%	100%
Total		51.1%	27.4%	7.0%	2.4%	5.9%	6.3%	100%

Age Class * Payment for 25% Reduction of Travel Time Crosstabulation

% within Age Class

		Payment for 25% Reduction of Travel Time						Total
		1 LE/Trip	2 LE/Trip	3 LE/Trip	4 LE/Trip	5 LE/Trip	> 5 LE/Trip	
Age Class	20 - 29 years	64.8%	20.5%	5.7%	0.8%	5.7%	2.5%	100%
	30 - 39 years	64.1%	20.9%	5.3%	1.9%	5.8%	1.9%	100%
	40 - 49 years	66.4%	17.4%	6.7%	2.0%	2.7%	4.7%	100%
	50 - 59 years	62.5%	12.5%	5.4%	1.8%	10.7%	7.1%	100%
	> 60 years	56.7%	23.3%	6.7%		6.7%	6.7%	100%
Total		64.3%	19.2%	5.9%	1.6%	5.5%	3.6%	100%

Appendix 3.7 Crosstabulation of Toll Value with Other Variables within the Sample

Age Class * Payment for 50% Reduction of Travel Time Crosstabulation

% within Age Class

		Payment for 50% Reduction of Travel Time						Total
		1 LE/Trip	2 LE/Trip	3 LE/Trip	4 LE/Trip	5 LE/Trip	> 5 LE/Trip	
Age Class	20 - 29 years	55.6%	23.4%	7.0%	1.8%	6.4%	5.8%	100%
	30 - 39 years	48.3%	31.3%	6.8%	1.9%	6.0%	5.7%	100%
	40 - 49 years	51.8%	26.1%	6.9%	3.2%	6.9%	5.0%	100%
	50 - 59 years	52.8%	27.4%	6.6%	0.9%	3.8%	8.5%	100%
	> 60 years	42.5%	25.0%	10.0%	7.5%	2.5%	12.5%	100%
Total		51.1%	27.4%	7.0%	2.4%	5.9%	6.3%	100%

Occupation * Payment for 25% Reduction of Travel Time Crosstabulation

% within Occupation

		Payment for 25% Reduction of Travel Time						Total
		1 LE/Trip	2 LE/Trip	3 LE/Trip	4 LE/Trip	5 LE/Trip	> 5 LE/Trip	
Occupation	Legislature, Administrative and Management Workers	48.6%	17.1%	7.1%	1.4%	20.0%	5.7%	100%
	Professional Workers	61.6%	19.8%	7.0%	2.3%	5.8%	3.5%	100%
	Technicians and Assistants	40.0%	60.0%					100%
	Clerks and related Workers	61.9%	19.0%	4.8%	4.8%	9.5%		100%
	Sale and Service Workers	54.7%	30.2%	5.7%	1.9%		7.5%	100%
	Farmers, Fishers and Hunters		100.0%					100%
	Craftsmen and related Workers	86.8%	8.6%	2.0%	0.7%	1.3%	0.7%	100%
	Production Workers and related Workers	50.0%	50.0%					100%
	Student	41.7%	25.0%	16.7%	4.2%	4.2%	8.3%	100%
	Housewife	37.5%	12.5%	37.5%		12.5%		100%
	Retired	80.0%	20.0%					100%
	Jobless	50.0%		50.0%				100%
	Others	65.2%	13.0%	4.3%		4.3%	13.0%	100%
Total		64.3%	19.2%	5.9%	1.6%	5.5%	3.6%	100%

Occupation * Payment for 50% Reduction of Travel Time Crosstabulation

% within Occupation

		Payment for 50% Reduction of Travel Time						Total
		1 LE/Trip	2 LE/Trip	3 LE/Trip	4 LE/Trip	5 LE/Trip	> 5 LE/Trip	
Occupation	Legislature, Administrative and Management Workers	34.8%	30.3%	6.7%	1.1%	10.1%	16.9%	100%
	Professional Workers	46.3%	32.9%	7.5%	2.0%	4.7%	6.7%	100%
	Technicians and Assistants	27.3%	45.5%	18.2%		9.1%		100%
	Clerks and related Workers	56.7%	23.3%	3.3%	6.7%	3.3%	6.7%	100%
	Sale and Service Workers	45.0%	26.7%	10.0%	3.3%	10.0%	5.0%	100%
	Farmers, Fishers and Hunters		100.0%					100%
	Craftsmen and related Workers	67.6%	23.0%	3.1%	1.6%	3.5%	1.2%	100%
	Production Workers and related Workers	36.4%	27.3%	18.2%	18.2%			100%
	Student	28.6%	14.3%	21.4%		17.9%	17.9%	100%
	Housewife	14.3%	28.6%	14.3%		28.6%	14.3%	100%
	Retired	50.0%	30.0%	10.0%	10.0%			100%
	Jobless			50.0%			50.0%	100%
	Others	62.1%	17.2%	3.4%		6.9%	10.3%	100%
Total		51.1%	27.4%	7.0%	2.4%	5.9%	6.3%	100%

Appendix 3.7 Crosstabulation of Toll Value with Other Variables within the Sample

Trip Purpose * Payment for 25% Reduction of Travel Time Crosstabulation

		% within Trip Purpose						Total
		Payment for 25% Reduction of Travel Time						
		1 LE/Trip	2 LE/Trip	3 LE/Trip	4 LE/Trip	5 LE/Trip	> 5 LE/Trip	
Trip Purpose	Work	71.9%	18.3%	4.1%	0.5%	3.6%	1.6%	100%
	Education	25.0%	50.0%	12.5%		6.3%	6.3%	100%
	Selling/Delivering	44.4%	27.8%	5.6%	5.6%		16.7%	100%
	Meeting/Business	46.3%	24.4%	4.9%	2.4%	17.1%	4.9%	100%
	Return to Work Place	25.0%	16.7%	16.7%	8.3%	16.7%	16.7%	100%
	Shopping/Eating	64.7%	11.8%	5.9%	5.9%	5.9%	5.9%	100%
	Sending/Fetching	70.0%	25.0%		5.0%			100%
	Recreational	50.0%	7.1%	7.1%		21.4%	14.3%	100%
	Medical Treatmentl	57.1%	14.3%	14.3%		14.3%		100%
	Social	60.7%	17.9%	7.1%	3.6%	3.6%	7.1%	100%
Other	50.0%	8.3%	25.0%	4.2%	8.3%	4.2%	100%	
Total		64.3%	19.2%	5.9%	1.6%	5.5%	3.6%	100%

Trip Purpose * Payment for 50% Reduction of Travel Time Crosstabulation

		% within Trip Purpose						Total
		Payment for 50% Reduction of Travel Time						
		1 LE/Trip	2 LE/Trip	3 LE/Trip	4 LE/Trip	5 LE/Trip	> 5 LE/Trip	
Trip Purpose	Work	53.5%	30.8%	6.4%	2.2%	4.2%	2.8%	100%
	Education	17.6%	17.6%	35.3%		11.8%	17.6%	100%
	Selling/Delivering	44.0%	20.0%	8.0%	4.0%	12.0%	12.0%	100%
	Meeting/Business	46.8%	23.4%	3.9%	5.2%	10.4%	10.4%	100%
	Return to Work Place	33.3%	16.7%	8.3%	8.3%		33.3%	100%
	Shopping/Eating	47.8%	17.4%	17.4%	4.3%	4.3%	8.7%	100%
	Sending/Fetching	65.9%	22.0%	2.4%		7.3%	2.4%	100%
	Recreational	41.2%	17.6%	5.9%		5.9%	29.4%	100%
	Medical Treatmentl	54.5%	18.2%	9.1%			18.2%	100%
	Social	33.3%	39.4%	6.1%	3.0%	9.1%	9.1%	100%
Other	57.4%	14.9%	6.4%		10.6%	10.6%	100%	
Total		51.1%	27.4%	7.0%	2.4%	5.9%	6.3%	100%

Monthly Income (L.E.) * Payment for 25% Reduction of Travel Time Crosstabulation

		% within Monthly Income (L.E.)						Total
		Payment for 25% Reduction of Travel Time						
		1 LE/Trip	2 LE/Trip	3 LE/Trip	4 LE/Trip	5 LE/Trip	> 5 LE/Trip	
Monthly Income (L.E.)	Less than 300 LE	62.5%	12.5%	25.0%				100%
	301-500 LE	83.1%	12.3%	1.5%	1.5%	1.5%		100%
	501-1000 LE	72.0%	19.0%	4.0%	1.0%	2.0%	2.0%	100%
	1001-2000 LE	57.4%	21.3%	10.2%	1.9%	5.6%	3.7%	100%
	2001-5000 LE	36.4%	36.4%	7.6%		16.7%	3.0%	100%
	> 5000 LE	12.5%	37.5%	8.3%	8.3%	16.7%	16.7%	100%
	No Income	37.5%	25.0%	21.9%	3.1%	6.3%	6.3%	100%
Refuse	81.3%	10.0%	0.6%	1.3%	3.1%	3.8%	100%	
Total		64.3%	19.2%	5.9%	1.6%	5.5%	3.6%	100%

Appendix 3.7 Crosstabulation of Toll Value with Other Variables within the Sample

Monthly Income (L.E.) * Payment for 50% Reduction of Travel Time Crosstabulation

% within Monthly Income (L.E.)

		Payment for 50% Reduction of Travel Time						Total
		1 LE/Trip	2 LE/Trip	3 LE/Trip	4 LE/Trip	5 LE/Trip	> 5 LE/Trip	
Monthly Income (L.E.)	Less than 300 LE	50.0%	37.5%			6.3%	6.3%	100%
	301-500 LE	57.7%	29.5%	7.7%	2.6%	2.6%		100%
	501-1000 LE	59.2%	23.1%	7.7%	1.5%	6.2%	2.3%	100%
	1001-2000 LE	44.7%	32.2%	6.6%	2.6%	7.2%	6.6%	100%
	2001-5000 LE	30.4%	34.8%	8.7%	4.3%	9.8%	12.0%	100%
	> 5000 LE	16.1%	22.6%	9.7%	9.7%	12.9%	29.0%	100%
	No Income	17.6%	20.6%	23.5%		17.6%	20.6%	100%
	Refuse	64.4%	24.3%	4.1%	1.5%	2.2%	3.4%	100%
Total		51.1%	27.4%	7.0%	2.4%	5.9%	6.3%	100%

Travel Time (Min) * Payment for 25% Reduction of Travel Time Crosstabulation

% within Travel Time (Min)

		Payment for 25% Reduction of Travel Time						Total
		1 LE/Trip	2 LE/Trip	3 LE/Trip	4 LE/Trip	5 LE/Trip	> 5 LE/Trip	
Travel Time (Min)	1 - 10 Min	69.7%	24.2%			6.1%		100%
	11 - 20 Min	72.0%	17.1%	3.7%		4.9%	2.4%	100%
	21 - 30 Min	66.1%	18.8%	7.1%	2.7%	4.5%	0.9%	100%
	31 - 40 Min	59.1%	28.8%	4.5%		1.5%	6.1%	100%
	41 - 50 Min	73.6%	14.5%	5.5%		4.5%	1.8%	100%
	51 - 60 Min	52.2%	26.1%	7.2%	2.9%	10.1%	1.4%	100%
	61 - 70 Min	50.0%	30.0%	10.0%		10.0%		100%
	71 - 80 Min	28.6%	14.3%	28.6%		14.3%	14.3%	100%
	81 - 90 Min	65.8%	15.8%	2.6%	5.3%		10.5%	100%
	91 - 100 Min		100.0%					100%
	101 - 110 Min	100.0%						100%
	111 - 120 Min	63.6%		4.5%	9.1%	18.2%	4.5%	100%
	121 - 130 Min	100.0%						100%
	131 - 140 Min			100.0%				100%
	141 - 150 Min	33.3%		33.3%		33.3%		100%
	> 150 Min"	14.3%	14.3%	14.3%			57.1%	100%
Total		64.3%	19.2%	5.9%	1.6%	5.5%	3.6%	100%

Appendix 3.7 Crosstabulation of Toll Value with Other Variables within the Sample

Travel Time (Min) * Payment for 50% Reduction of Travel Time Crosstabulation

		% within Travel Time (Min)						Total
		Payment for 50% Reduction of Travel Time						
		1 LE/Trip	2 LE/Trip	3 LE/Trip	4 LE/Trip	5 LE/Trip	> 5 LE/Trip	
Travel Time (Min)	1 - 10 Min	54.0%	30.0%	2.0%	8.0%	2.0%	4.0%	100%
	11 - 20 Min	57.1%	31.7%	2.4%	0.8%	5.6%	2.4%	100%
	21 - 30 Min	55.3%	26.8%	7.8%	2.2%	3.9%	3.9%	100%
	31 - 40 Min	55.6%	18.9%	13.3%	2.2%	5.6%	4.4%	100%
	41 - 50 Min	55.7%	29.7%	3.8%	1.3%	3.8%	5.7%	100%
	51 - 60 Min	36.7%	34.7%	13.3%	4.1%	6.1%	5.1%	100%
	61 - 70 Min	44.4%	22.2%		11.1%	11.1%	11.1%	100%
	71 - 80 Min	12.5%	12.5%	12.5%		37.5%	25.0%	100%
	81 - 90 Min	43.9%	22.0%	9.8%		12.2%	12.2%	100%
	91 - 100 Min				100.0%			100%
	101 - 110 Min		100.0%					100%
	111 - 120 Min	41.7%	16.7%	4.2%		12.5%	25.0%	100%
	121 - 130 Min	100.0%						100%
	131 - 140 Min					100.0%		100%
	141 - 150 Min	33.3%				33.3%	33.3%	100%
> 150 Min"	20.0%	10.0%	10.0%		10.0%	50.0%	100%	
Total		51.1%	27.4%	7.0%	2.4%	5.9%	6.3%	100%

No. of Trips per Week * Payment for 25% Reduction of Travel Time Crosstabulation

		% within No. of Trips per Week						Total
		Payment for 25% Reduction of Travel Time						
		1 LE/Trip	2 LE/Trip	3 LE/Trip	4 LE/Trip	5 LE/Trip	> 5 LE/Trip	
No. of Trips per Week	1 - 2 Trips/Week	54.0%	17.3%	10.0%	4.0%	6.0%	8.7%	100%
	3 - 4 Trips/Week	65.4%	21.8%	2.6%		7.7%	2.6%	100%
	5 - 6 Trips/Week	49.5%	27.8%	5.2%	2.1%	12.4%	3.1%	100%
	7 - 8 Trips/Week	58.8%	21.6%	11.8%		5.9%	2.0%	100%
	9 - 10 Trips/Week	66.7%	25.9%	7.4%				100%
	11 - 12 Trips/Week	77.2%	17.5%	1.8%	1.8%		1.8%	100%
	13 - 15 Trips/Week	72.7%	21.2%	6.1%				100%
	15 - 20 Trips/Week	80.0%	20.0%					100%
	21 - 30 Trips/Week	86.7%	6.7%			6.7%		100%
	31 - 40 Trips/Week	100.0%						100%
	41 - 50 Trips/Week	100.0%						100%
	51 - 60 Trips/Week	100.0%						100%
	61 - 70 Trips/Week	100.0%						100%
	> 70 Trips/Week	88.9%	11.1%					100%
Total		64.3%	19.2%	5.9%	1.6%	5.5%	3.6%	100%

Appendix 3.7 Crosstabulation of Toll Value with Other Variables within the Sample

No. of Trips per Week * Payment for 50% Reduction of Travel Time Crosstabulation

% within No. of Trips per Week

		Payment for 50% Reduction of Travel Time						Total
		1 LE/Trip	2 LE/Trip	3 LE/Trip	4 LE/Trip	5 LE/Trip	> 5 LE/Trip	
No. of Trips per Week	1 - 2 Trips/Week	49.0%	25.3%	4.9%	2.4%	8.2%	10.2%	100%
	3 - 4 Trips/Week	38.5%	29.7%	12.1%	1.1%	9.9%	8.8%	100%
	5 - 6 Trips/Week	33.3%	32.5%	11.4%	6.1%	7.0%	9.6%	100%
	7 - 8 Trips/Week	39.0%	33.9%	11.9%	1.7%	8.5%	5.1%	100%
	9 - 10 Trips/Week	63.6%	21.2%	9.1%	3.0%	3.0%		100%
	11 - 12 Trips/Week	56.0%	34.5%	3.6%	2.4%	2.4%	1.2%	100%
	13 - 15 Trips/Week	56.9%	27.5%	9.8%	2.0%	2.0%	2.0%	100%
	15 - 20 Trips/Week	61.5%	30.8%	7.7%				100%
	21 - 30 Trips/Week	77.8%	11.1%			5.6%	5.6%	100%
	31 - 40 Trips/Week	75.0%	25.0%					100%
	41 - 50 Trips/Week	85.2%	14.8%					100%
	51 - 60 Trips/Week	84.2%	15.8%					100%
	61 - 70 Trips/Week	93.8%	6.3%					100%
	> 70 Trips/Week	61.1%	33.3%	5.6%				100%
Total		51.1%	27.4%	7.0%	2.4%	5.9%	6.3%	100%

APPENDIX 5.1

TRAFFIC ZONING SYSTEM

Traffic Zoning System

Appendix 5-1

ZONE	ZONE NAME	QISM	QISM NAME	SECTOR	SECTOR NAME
1	Tebeen al-Qebleyya	101	Tebeen	6	Helwan
2	Hekr al-Tebeen				
3	Madinat al-Solb				
4	Masaken al-Tebeen al-Shaebey				
5	al-Masaken al-Eqtesadeyya	102	Helwan		
6	al-Maesara al-Balad				
7	al-Maesara al-Mahata				
8	Helwan al-Bahareyya				
9	Helwan al-Balad				
10	Helwan al-Sharqeyya				
11	Helwan al-Gharbeyya				
12	Helwan al-Qebleyya				
13	Kafr al-Olw				
14	Monshaet Naser (Qism Helwan)				
15	Ain Helwan inserted by LJ	103	15th of May City		
16	Sheyakha 1				
17	Sheyakha 2				
18	Sheyakha 3	104	Maadi	7	Maadi
19	Maeady al-Khobeiry al-Sharqe				
20	Maeady al-Khobeiry al-Gharbe				
21	Maeady al-Khobeiry al-Wosta				
22	Maeady al-Sarayal al-Sharqey				
23	Maeady al-Sarayal al-Gharbey				
24	Tora al-Hegara	105	Tora		
25	Tora al-Balad				
26	Tora al-Heit				
27	Tora al-Asmant				
28	Mansheyet al-Masry				
29	al-Zaharaa				
30	Abou al-Soeod & al-Madabegh				
31	Athar al-Naby				
32	al-Anwar & Eshash al-Baroud				
33	al-Khokha & al-Qanaya				
34	al-Dayoura				
35	al-Roda & al-Meqyas				
36	al-Kofour & Saei al-Bahr				
37	al-Manyal al-Sharqy				
38	al-Manyal al-Gharby				
39	Ain al-Seera				
40	Fom al-Khaleeg & Deir al-Nah				
41	Kom Ghorab	107	Sayeda Zeinab		
42	al-Ensha & al-Moneera				
43	al-Baghala				
44	al-Hanafy				
45	al-Darb al-Gadeed				
46	al-Sabbaein				
47	al-Sayeda				
48	al-Atrees				
49	al-Ainy				
50	al-Kabsh				
51	Hadayeq Zeinhom				
52	Khayrat				
53	Darb al-Gamameez				
54	Zeinhom				
55	Sonqor				
56	Toloun				
57	al-Abageya				

Traffic Zoning System

ZONE	ZONE NAME	QISM	QISM NAME	SECTOR	SECTOR NAME
58	al-Emamein				
59	al-Baqly				
60	al-Tonsy	108	Khaleefa	8	Khaleefa
61	al-Hattaba				
62	al-Helmeya				
63	Darb al-Hosr				
64	Darb Ghozeya				
65	al-Saleeba				
66	al-Qadreya				
67	al-Mahgar				
68	Arab al-Yasar				
69	al-Balaqsa	109	Abdeen	9	CBD
70	al-Sheikh Abdallah				
71	al-Dawaween				
72	al-Fawala				
73	al-Saqqayeen				
74	Bab al-Looq				
75	Rahbat Abdeen				
76	Gheit al-Edda				
77	al-Ramly	110	Mosky		
78	al-Nouby				
79	al-Lewae Ameen al-Shereef				
80	al-Manasra				
81	Darb al-Geneina				
82	Safey al-Deen				
83	Kom al-Sheikh Salama				
84	al-Ismaileya	111	Qasr El Neel		
85	Garden City				
86	Qasr al-Dobara				
87	Maeroof				
88	Abou al-Ela	112	Boolaq		
89	al-Khoutery				
90	al-Qallaya				
91	Eshash al-Nahl				
92	al-Sabtaya				
93	al-Aleemy				
94	Sharkas				
95	Houdh al-Zohour				
96	Sooq al-Asr				
97	al-Adaweya				
98	al-Rehany	113	Azbakeya		
99	al-Qolaly				
100	al-Fagala				
101	al-Qebleyya				
102	Oraby (Tawfeeqeya)				
103	Klot Bek				
104	Darb Shaghlan	114	Darb El Ahmar		
105	al-Dawoudeya				
106	al-Sorougeyya				
107	al-Amry				
108	Haret al-Room				
109	Darb Saeada				
110	al-Mogharbeleen				
111	Bab al-Wazeer & al-Ghareeb				
112	Sooq al-Selah				
113	al-Azhar	115	Gamaleya		
114	al-Beiraqdar				
115	Bab al-Fotooh				
116	al-Hamzawy				

Traffic Zoning System

ZONE	ZONE NAME	QISM	QISM NAME	SECTOR	SECTOR NAME
117	Qasr al-Shouq				
118	al-Kordy				
119	al-Darrasa	115	Gamaleya	9	CBD
120	al-Shaerany				
121	Gawhar al-Qaed				
122	al-Mansoureyya				
123	al-Banhawy	116	Bab El Shaareya		
124	al-Shomboky				
125	al-Sawaby				
126	Beket al-Ratly				
127	al-Mansy				
128	al-Nasr				
129	Bab al-Bahr				
130	Bab al-Sheareya				
131	Sidi Madyan				
132	Abou Khouda	117	Daher		
133	al-Ganzoury				
134	al-Sakakeeny				
135	al-Zaher				
136	al-Qoubeisy				
137	Ghamra				
138	al-Sharabeyya	118	Sharabeya	10	Shobra
139	al-Azab				
140	al-Zaweyya al-Hamra al-Balad				
141	Mahmasha				
142	al-Terah al-Boulaqeyya	119	Shobra		
143	al-Shamashergy				
144	al-Attar				
145	Gesr Shoubra				
146	Ibn al-Rasheed	120	Rod El Farag		
147	al-Mabbeyadha				
148	Gazeerat Badran				
149	Rodh al-Farag al-Balad				
150	Tosoun				
151	Qasouret al-Shawwam				
152	Asead	121	Sahel		
153	al-Barrad				
154	al-Khazendara				
155	al-Sahel				
156	Borham				
157	Shereef				
158	Menyet al-Serg				
159	al-Mohammady	122	Wayly	11	Masr El Gedeeda
160	al-Zaefarany				
161	al-Sarayat				
162	al-Abbaseya al-Bahareyya				
163	al-Abbaseya al-Sharqeyya				
164	al-Abbaseya al-Gharbeyya				
165	al-Abbaseya al-Qebleyya				
166	Bein al-Ganayen				
167	Ganayen al-Wayleyya				
168	Kobry al-Qobbah				
169	al-Hadaeq	123	Hadaeq El Qoba		
170	al-Khassah				
171	al-Qobba				
172	al-Wayly al-Kabeer Sharq				
173	al-Wayly al-Kabeer Gharb				
174	Hadaeq al-Qobbah				
175	Masaken al-Ameereyya al-Gano				

Traffic Zoning System

ZONE	ZONE NAME	QISM	QISM NAME	SECTOR	SECTOR NAME
176	Mansheyat al-Sadr				
177	al-Zaytoon al-Bahareyya	124	Zaytoon		
178	al-Zaytoon al-Sharqeyya	124	Zaytoon	11	Masr El Gedeeda
179	al-Zaytoon al-Gharbeyya				
180	al-Zaytoon al-Qebleyya				
181	Masaken al-Ameereyya al-Sham				
182	al-Arab (Tal al-Hesn)	125	Matareya	13	Ain Shams
183	al-Matareyya al-Bahareyya				
184	al-Matareyya al-Gharbeyya				
185	al-Matareyya al-Qebleyya				
186	Shagaret Maryam				
187	Arab al-Tawayla				
188	Arab al-Hesn				
189	Ain Shams al-Gharbeyya				
190	Rabeah al-Adaweyya	126	Nasr City	12	Nasr City
191	al-Sharekat				
192	al-Golf				
193	al-Nady al-Ahly				
194	al-Manteqah al-Aashra (10)				
195	al-Hayy al-Aasher (10)				
196	al-Manteqah al-Ola (1)				
197	al-Manteqah al-Sadsa (6)				
198	al-Manteqah al-Thamna (8)				
199	al-Wafae & al-Amal				
200	al-Hadeeqa al-Dawleyya				
201	al-Manteqah al-Sabeah (7)				
202	Sharq al-Manteqah al-Sadsa				
203	Ezbet al-Haggana (Kilo 4.5)				
204	Masaken al-Mohandseen				
205	Manteqat al-Senema				
206	al-Hayy al-Sabei (7)	127	Nasr City - Qism 2	11	Masr El Gedeeda
207	al-Hayy al-Sades (6)				
208	al-Estad				
209	al-Sarayat al-Sharqeyya				
210	Gameat al-Azhar				
211	Ezbet al-Arab				
212	Hady al-Sekkah al-Hadeed				
213	al-Bostan	128	Masr El Gedeeda		
214	Almaza				
215	al-Montazah				
216	Mansheyat al-Bakry				
217	al-Nozha	129	Nozha	12	Nasr City
218	al-Haykesteb				
219	al-Matar				
220	Sheraton al-Matar				
221	Madinat Badr data inserted b	130	Badr City		
222	al-Zaharaa & Masaken al-Helm	131	Ain Shams	13	Ain Shams
223	Helmeyyat al-Zaytoun				
224	Helmeyyat al-Naeam				
225	Tolombat Ain Shams				
226	Ain Shams al-Sharqeyya				
227	Mansheyyet al-Tahreer				
228	Masaken al-Zaweyya al-Hamra	132	Zawya El Hamra	10	Shobra
229	al-Ameereyya				
230	al-Salam al-Sharqeyya	133	Salam City	14	Salam City
231	al-Salam al-Gharbeyya				
232	al-Assarah al-Gadeedah				
233	Beket al-Nasr				
234	al-Nahdha				

Traffic Zoning System

ZONE	ZONE NAME	QISM	QISM NAME	SECTOR	SECTOR NAME
235	Mohammad Mazhar	134	Zamalek	9	CBD
236	al-Gabalayah				
237	Omar al-Khayyam				
238	al-Khazzan	135	Monshaet Naser	8	Khaleefa
239	al-Maedasa				
240	al-Mahager				
241	al-Soltan Barqooq				
242	Qayetbay				
243	Monshaet Naser				
244	al-Basteen al-Sharqeyya				
245	al-Basteen al-Gharbeyya				
246	al-Esaweyya				
247	Dar al-Salam				
248	Ezbet Gebreel				
249	Ezbet Fahmy				
250	Ezbet Nafeh				
251	al-Marg al-Bahareyya	138	Marg	14	Salam City
252	al-Marg al-Qebleyya				
253	Berket al-Hag				
254	Ezbet al-Nakhl				
255	Kafr al-Basha				
256	Kaft al-Shorafae				
257	Madinat 10th of Ramadan	1309	10th of Ramadan City	18	10th of Ramadan City
258	al-Khankah	1403	Khanka (Markaz)	17	Qanater
259	Madeenat al-Oboor				
260	Abou Zaebal				
261	al-Khosoos				
262	al-Qalag				
263	al-Manayel				
264	al-Menyah				
265	Seryaqous				
266	Sendewah				
267	Arab al-Abaydah				
268	Arab al-Olayqat				
269	al-Gabal al-Asfar				
270	Thalatha wa Eshreen Yolya (2				
271	Kafr Hamzah				
272	Kafr Obyan				
273	Mazraet al-Gabal al-Asfar				
274	Madeenat al-Qanater al-Khayr				
275	Abou al-Gheit				
276	Aghoor al-Soghra				
277	al-Akhmeyyeen				
278	al-Baradeah & Khelwateha				
279	al-Kharqaneyya				
280	Shoubra Shehab				
281	al-Moneera				
282	Basoos				
283	Behada				
284	Sandabees				
285	Shalaqan				
286	Qarnafeel				
287	Kafr Seleem				
288	Kafr al-Shourafaa al-Gharby				
289	Kafr Aleem	1405	Shebeen El Qanater (Markaz)	17	Qanater
290	Madinat Shebeen al-Qanater				
291	al-Ahraz				
292	al-Gaeafra				
293	al-Qalzam				

Traffic Zoning System

ZONE	ZONE NAME	QISM	QISM NAME	SECTOR	SECTOR NAME
294	al-Hesaneyya				
295	al-Hasafa				
296	al-Zahweyyeen	1405	Shebeen El Qanater (Markaz)	17	Qanater
297	al-Salmaneyya				
298	al-Shoubak				
299	al-Attara				
300	al-Qasheesh				
301	al-Kom al-Ahmar				
302	al-Mareeg				
303	al-Ghareezy				
304	Tal Beni Tameem				
305	Tahanoub				
306	Tahooreyya				
307	Arab al-Shaeara				
308	Arab al-Sawalha				
309	Kafr al-Deir				
310	Kafr Saad Beheiry				
311	Kafr al-Shoubak				
312	Kafr al-Sahby				
313	Kafr Sandowa				
314	Kafr Shebeen				
315	Kafr Taha				
316	Kafr Tahooreyya				
317	Kafr al-Samn				
318	Kafr Solayman				
319	Monsheat al-Keram				
320	Menyet Shebeen				
321	Nazlet Arab Gohayna				
322	Noub Taha				
323	Nawa				
324	Shoubra al-Kheima	1406	Shobra El Kheima (1)	15	Shobra El Kheima
325	Begam				
326	Damanhour Shoubra				
327	Bahteem	1407	Shobra El Kheima (2)		
328	Mostorod				
329	Madinat Qalyob	1409	Qalyob (Qism)	16	Qalyob
330	Nayy	1410	Qalyob (Markaz)		
331	al-Eslah al-Zraey				
332	al-Sadd				
333	al-Sabah				
334	Belqas				
335	Halabah & Kafr al-Seil				
336	Zaweyyat al-Naggar				
337	Sandyon				
338	Sanafeer				
339	Tanan				
340	Qalma				
341	Kafr Abou Gomah				
342	Kafr Ramada & al-Torgoman				
343	Kom Ashfeen				
344	Mantay				
345	Meet Halfa				
346	Meet Nama				
347	al-Moneera	2101	Imbaba	3	Doqi
348	Kafr al-Sheikh Ismaeel				
349	Gezeeret Imbaba				
350	Abdel Naeem				
351	Kafr al-Shawam				
352	al-Tahreer				

Traffic Zoning System

ZONE	ZONE NAME	QISM	QISM NAME	SECTOR	SECTOR NAME
353	Madinat al-Ommal				
354	Matar Imbaba				
355	Meet Kerdek				
356	al-Houteyya	2102	Agoosa		
357	Gezeeret Meet Oqba				
358	al-Agouza				
359	Meet Oqba				
360	Madinat al-Awqaf				
361	al-Doqqy	2103	Doqy		
362	al-Moneeb	2104	Giza	4	Giza
363	Gazeerat al-Dahab				
364	Harra Ola (1)				
365	Harra Thanya (2)				
366	Harra Thaltha (3)				
367	Harra Rabeah (4)				
368	Saqeyyet Mekky				
369	Abou Qatadah	2105	Boolaq El Dakroor	3	Doqi
370	Bolaq al-Dakroor				
371	Zeneen				
372	Kafr Taharmas				
373	Mansheyyet Alyan				
374	Nazlet Khalaf				
375	Nazlet Bahgat				
376	Ghataty	2106	Ahram	4	Giza
377	Kafret al-Gabal				
378	Kafret Nassar & Fondoq Meena				
379	Monshaet al-Bakary				
380	Nazlet al-Batran				
381	Nazlet al-Samman				
382	Madinat 6th of October	2107	6th of October City	1	6th of October City
383	Madinat al-Hawamdeyya	2108	Hawamdeya	5	South Giza
384	Omm Khenan				
385	Abou al-Nomros	2109	Giza (Markaz)	4	Giza
386	al-Harraneyya				
387	al-Manawat				
388	Tersa				
389	Zaweyyat Abou Moslem				
390	Shoubramant				
391	Tammoh				
392	Manyal Sheeha				
393	Meet Shamas				
394	Meet Qadoos				
395	Nazlet al-Ashtar				
396	Bani Yousof				
397	Madinat al-Badrasheen	2110	Badrasheen (Markaz)	5	South Giza
398	Abou Ragrwan al-Qebly				
399	Abou Ragrwan al-Bahary				
400	Abou Seir				
401	al-Shenbab				
402	al-Shobak al-Gharby				
403	al-Tarfaya				
404	al-Azeezeyya				
405	Qaleit al-Marazeeq				
406	Dahshoor				
407	Zawyyet Dahshoor				
408	Zahran & Gaber				
409	Saqqara				
410	Mazghoona				
411	Monshaet Dahshoor				

Traffic Zoning System

ZONE	ZONE NAME	QISM	QISM NAME	SECTOR	SECTOR NAME
412	Monshaet Kaseb				
413	Meet Raheena				
414	Nazlet al-Shobak	2110	Badrasheen (Markaz)	5	South Giza
415	Abou Rawwash	2113	Imbaba (Markaz)	2	Imbaba Markaz
416	al-Akhsas				
417	al-Galatma				
418	al-Hesaneyyeen				
419	al-Rahawy				
420	al-Sabeel				
421	al-Moatamadeyya				
422	al-Manashy				
423	al-Mansoureyya				
424	Omm Deenar				
425	Beqash				
426	Berak al-Khayyam				
427	Bani Magdool				
428	Baharmas				
429	Gezzaya				
430	Zat al-Kom				
431	Saft al-Laban				
432	Kerdasa				
433	Kafr Hegazy				
434	Kafr Hakeem				
435	Kombara				
436	Mansheyet al-Qanater				
437	Mansheyet Radhwan				
438	Mahmood Abdel Samad				
439	Nahya				
440	Nekla				
441	Madinat Oseem	2116	Oseem (Markaz)		
442	al-Barageel				
443	al-Zaydeyya				
444	al-Qeratteyyeen				
445	al-Kom al-Ahmar				
446	Baratss				
447	Shenbary				
448	Saqeel				
449	Sayyeda				
450	Bashteel	2117	Waraq		
451	Gezeeret Mohammad				
452	Gezeeret Warraq al-Hadhar				
453	Warraq al-Hadhar & Ambooba &				
454	Warraq al-Arab				
455	Tanash & Nazlet al-Zomor				
456	al-Talbeyya al-Qebleyya	2118	Omraneya	4	Giza
457	al-Omraneyya al-Sharqeyya				
458	al-Omraneyya al-Gharbeyya				
459	al-Konayyesa				
460	al-Kom al-Akhdhar				
461	al-Haram				
462	al-Qattameyya	127	Nasr City - Qism 2	11	Masr El Gedeeda
463	Shorouq City inserted by LJ	129	Nozha	12	Nasr City
464	New Cairo inserted by LJ	139	New Cairo		
465	Hykisteb	129	Nozha	12	Nasr City
466	Al Obour Market	1403	Khanka (Markaz)	14	Salam City
467	Madinat 6th of October	2107	6th of October City	1	6th of October City
468	Madinat 6th of October				
469	Madinat 10th of Ramadan	1309	10th of Ramadan City	18	10th of Ramadan City
470	Madinat 10th of Ramadan				

Traffic Zoning System

ZONE	ZONE NAME	QISM	QISM NAME	SECTOR	SECTOR NAME
471	Abou Rawwash	2113	Imbaba (Markaz)	2	Imbaba Markaz
472	Abou Rawwash				
473	Spare Zone				
474	Spare Zone				
475	Intercity Bus Terminal (Al Moneeb)		Special Generator Zones		Special Generator Zones
476	Intercity Bus Terminal (Al Torgoman)				
477	Intercity Bus Terminal (Almaza)				
478	Intercity Bus Terminal (New Al Marg)				
479	Intercity Bus Terminal (Aboud)				
480	Ramsis Square (Rail Station)				
481	Cairo Airport				
482	Giza Sub-urban Station				
483	Spare Zone				
484	Ain Shams ENR Station				
485	Upper Egypt Agricultural Road		External Zones		External Zones
486	Giza Asyout Desert Road				
487	Cairo Fayoum Road				
488	Cairo Wahaat Road				
489	Cairo Alexandria Desert Road				
490	Qanater El Khairyiah Khataba Road				
491	Qanater El Shbeen El Koum Road				
492	Shatanouf Ashmoun Road				
493	Qanater El Khairyiah				
494	Cairo Alexandria Agricultural Road				
495	Shbeen El Qanater Tokh Road				
496	Shbeen El Qanater Belbeis Road				
497	Cairo Ismalia Road				
498	Haiksteb Belbeis Road				
499	10th of Ramadan Belbies Road				
500	Cairo Ismalia Desert Road				
501	Cairo Suez Desert Road				
502	Qattammia Ain El Sokhna Road				
503	Giza El Saf Road				
504	al-Zaefarany	122	Wayly	11	Masr El Gedeeda
505	al-Zaefarany				
506	al-Zaytoon al-Qebleyya	124	Zaytoon		
507	al-Zaytoon al-Qebleyya				
508	Mansheyat al-Bakry	128	Masr El Gedeeda		
509	Mansheyat al-Bakry				
510	Mansheyat al-Bakry				
511	al-Montazah				
512	al-Golf	126	Nasr City	12	Nasr City
513	al-Manteqah al-Ola (1)				
514	al-Estad	127	Nasr City - Qism 2	11	Masr El Gedeeda
515	al-Manteqah al-Sadsa (6)	126	Nasr City	12	Nasr City
516	al-Manteqah al-Thamna (8)				
517	Sharq al-Manteqah al-Sadsa				
518	al-Manteqah al-Aashra (10)				
519	Ezbet al-Haggana (Kilo 4.5)				
520	New Cairo inserted by LJ	139	New Cairo		
521	New Cairo inserted by LJ				
522	al-Hayy al-Aasher (10)	126	Nasr City		
523	al-Hayy al-Aasher (10)				
524	Spare Zone				
525	Spare Zone				

In year 2005, zone no.464-474 is spare zone

APPENDIX 5.2

OD MATRIX FOR ALL VEHICLES 2005

OD Matrix for All Vehicles 2005

	6th of October	Imbaba Markaz	Dokki	Giza	South Giza	Helwan	Maaadi	Khaleefa	CBD	Shoubra	Masr El Gadida	Nasr City	Ain Shams	Salam City	Shoubra El Khima	Qalioub	Qanater	10th of Ramadan	Total
6th of October	2,782	1,018	1,200	2,094	211	235	377	719	2,145	655	433	661	192	374	306	94	108	1	13,605
Imbaba Markaz	1,018	38,493	28,858	20,750	1,349	1,424	3,874	5,210	14,839	6,219	5,939	4,322	3,349	3,549	5,544	5,834	3,201	529	154,301
Dokki	1,200	28,858	78,707	46,278	5,371	5,559	12,970	17,628	37,733	18,896	17,885	12,025	8,007	5,835	13,577	7,311	5,178	518	323,536
Giza	2,094	20,751	46,278	90,628	11,526	6,357	16,661	20,632	27,149	9,691	11,802	9,638	4,351	2,849	5,890	2,770	1,945	412	291,424
South Giza	211	1,349	5,371	11,526	21,130	6,206	2,665	2,750	3,365	955	1,582	1,927	407	266	674	282	233	174	61,073
Helwan	235	1,424	6,206	6,357	6,206	69,216	17,211	6,347	10,290	3,157	6,494	7,828	2,473	1,836	1,497	525	841	628	148,125
Maaadi	377	3,874	12,971	16,661	2,665	17,211	42,831	16,155	19,211	5,706	11,428	11,075	3,772	2,562	2,674	1,143	1,537	356	172,209
Khaleefa	719	5,210	17,628	20,632	2,750	6,348	16,156	19,270	20,483	7,997	14,181	12,000	5,831	3,698	3,793	1,145	1,585	345	159,771
CBD	2,145	14,840	37,734	27,149	3,364	10,290	19,212	20,484	41,106	27,784	29,863	20,421	14,549	9,476	15,158	5,939	5,090	696	305,300
Shoubra	655	6,219	18,896	9,691	955	3,157	5,706	7,997	27,783	28,155	23,143	13,509	10,151	6,551	13,506	5,135	4,300	652	186,161
Masr El Gadida	433	5,940	17,885	11,802	1,582	6,494	11,428	14,181	29,864	23,143	56,556	37,083	27,032	16,339	13,996	5,222	8,039	1,325	288,344
Nasr City	661	4,322	12,025	9,638	1,927	7,828	11,075	12,000	20,420	13,509	37,083	57,781	19,310	16,750	9,517	4,625	8,584	3,005	250,060
Ain Shams	192	3,349	8,007	4,351	407	2,472	3,772	5,831	14,549	10,151	27,032	19,310	24,124	12,747	8,239	3,923	6,397	828	155,681
Salam City	374	3,549	5,835	2,849	266	1,836	2,563	3,698	9,476	6,551	16,339	16,750	12,747	21,735	7,656	6,346	11,138	1,084	130,792
Shoubra El Khima	306	5,544	13,577	5,890	674	1,497	2,674	3,793	15,158	13,506	13,996	9,517	8,239	7,656	27,236	9,238	8,463	398	147,362
Qalioub	94	5,835	7,311	2,770	282	525	1,143	1,145	5,940	5,135	5,221	4,625	3,923	6,346	9,239	31,554	6,893	407	98,388
Qanater	108	3,201	5,178	1,945	233	841	1,537	1,584	5,090	4,300	8,037	8,584	6,397	11,139	8,463	6,892	43,071	841	117,441
10th of Ramadan	1	529	518	412	174	628	356	345	696	652	1,325	3,005	828	1,084	398	407	841	7,795	19,994
Total	13,605	154,305	323,539	291,423	61,072	148,124	172,211	159,769	305,297	186,162	288,339	250,061	155,682	130,792	147,363	98,385	117,444	19,994	3,023,567

OD Matrix for All Vehicles 2012

	6th of October	Imbaba Markaz	Dokki	Giza	South Giza	Helwan	Maaadi	Khaleefa	CBD	Shoubra	Masr El Gadida	Nasr City	Ain Shams	Salam City	Shoubra El Khima	Qalioub	Qanater	10th of Ramadan	Total
6th of October	29,825	7,509	10,364	23,486	1,621	1,473	2,067	3,516	7,453	2,022	2,009	1,790	1,128	826	1,629	1,968	591	1,446	100,723
Imbaba Markaz	7,509	87,405	39,329	23,712	1,480	2,162	4,188	6,343	18,574	6,074	8,625	6,841	2,674	2,006	3,592	3,783	1,341	866	226,504
Dokki	10,364	39,329	101,622	53,440	5,237	8,865	15,522	20,526	44,622	21,171	26,450	19,716	9,641	6,955	14,984	7,819	5,652	1,276	413,191
Giza	23,486	23,712	53,440	125,543	13,599	7,799	16,638	23,648	34,575	11,777	15,967	13,483	5,188	3,790	7,621	4,293	2,958	891	388,409
South Giza	1,621	1,480	5,237	13,599	39,130	7,389	2,847	3,324	4,740	1,248	2,319	2,142	571	408	814	421	326	228	87,844
Helwan	1,473	2,162	7,797	7,388	94,905	21,893	7,371	7,371	11,798	3,464	7,477	5,775	2,331	1,784	2,655	1,364	1,236	940	190,678
Maaadi	2,067	4,188	15,522	16,637	2,847	21,893	59,397	18,809	22,729	7,014	14,836	12,372	3,904	2,961	4,152	2,381	1,990	651	214,350
Khaleefa	3,516	6,343	20,527	23,647	3,324	7,371	18,809	26,599	25,970	10,625	21,105	18,215	6,028	4,316	5,557	2,354	2,232	651	207,189
CBD	7,454	18,574	44,621	34,576	4,740	11,797	22,728	25,972	49,113	31,487	35,854	31,418	16,020	11,720	17,729	8,760	7,427	2,018	382,008
Shoubra	2,022	6,073	21,171	11,777	1,248	3,464	7,014	10,625	31,487	44,329	28,288	19,505	11,483	7,316	16,028	7,897	6,119	1,427	237,273
Masr El Gadida	2,009	8,624	26,451	15,966	2,319	7,477	14,836	21,106	35,854	28,288	91,145	70,927	37,755	25,718	19,409	8,896	13,452	3,139	433,371
Nasr City	1,790	6,843	19,718	13,483	2,141	5,775	12,372	18,215	31,419	19,503	70,925	136,502	28,659	29,267	14,849	7,860	11,988	11,918	443,227
Ain Shams	1,128	2,674	9,641	5,188	571	2,331	3,904	6,028	16,047	11,483	37,755	28,659	30,724	16,463	10,787	4,876	7,869	3,156	199,284
Salam City	826	2,005	6,955	3,790	408	1,784	2,961	4,316	11,720	7,316	25,718	29,267	16,463	34,934	8,138	5,292	11,293	2,919	176,105
Shoubra El Khima	1,629	3,592	14,984	7,621	814	2,655	4,152	5,557	17,729	16,028	19,409	14,849	10,787	8,138	33,434	12,818	9,362	3,086	186,644
Qalioub	1,968	3,783	7,819	4,293	421	1,364	2,381	2,354	8,760	7,897	8,896	7,861	4,876	5,292	44,485	44,485	8,080	2,381	135,729
Qanater	591	1,341	5,652	2,957	325	1,236	1,990	2,232	7,427	6,119	13,450	11,988	7,869	11,294	8,081	8,081	81,387	1,722	175,023
10th of Ramadan	1,446	866	1,276	891	228	940	651	651	2,018	1,427	3,139	11,918	3,156	2,919	3,086	2,381	1,722	36,083	74,798
Total	100,724	226,504	413,194	388,403	87,841	190,680	214,350	207,192	382,035	237,272	433,367	443,228	199,257	176,107	186,644	135,729	175,025	74,798	4,272,350

OD Matrix for All Vehicles 2022

	6th of October	Imbaba Markaz	Dokki	Giza	South Giza	Helwan	Maaadi	Khaleefa	CBD	Shoubra	Masr El Gadida	Nasr City	Ain Shams/Salam City	Shoubra El Khima	Qalioub	Qanater	10th of Ramadan	Total
6th of October	47,154	28,149	25,850	76,323	5,679	5,022	9,752	17,787	27,585	7,289	8,825	6,041	2,732	1,826	3,851	1,694	2,531	284,815
Imbaba Markaz	28,149	121,150	54,306	32,719	1,570	3,267	5,366	8,744	26,335	8,568	11,604	10,965	3,832	2,938	6,321	2,255	1,413	334,272
Dokki	25,850	54,306	138,109	72,619	6,513	13,975	19,946	27,232	61,434	29,398	35,036	35,881	14,190	11,177	8,975	9,375	3,553	587,437
Giza	76,323	32,721	72,619	168,834	16,184	9,753	17,817	29,633	46,307	15,350	22,521	19,482	7,644	5,770	5,309	5,143	1,674	563,987
South Giza	5,679	1,570	6,513	16,184	69,139	11,547	2,753	3,386	5,664	1,368	2,770	2,523	707	500	449	482	331	132,628
Helwan	5,024	3,270	13,975	9,753	11,547	144,362	25,104	10,598	19,940	6,082	13,289	10,669	3,904	3,041	1,863	2,693	1,455	290,961
Maaadi	9,587	5,254	19,710	17,254	2,665	23,120	85,089	23,111	27,099	8,702	18,850	20,233	5,000	3,903	2,641	2,942	921	281,819
Khaleefa	17,737	8,745	26,995	29,461	3,321	9,962	23,912	43,462	37,056	13,385	28,713	27,248	8,449	6,408	3,080	4,021	1,670	301,968
CBD	27,569	26,341	61,414	46,307	5,664	19,940	27,974	38,045	75,057	42,030	48,000	56,417	22,462	18,573	11,612	13,628	7,078	574,079
Shoubra	7,145	8,534	29,350	15,323	1,368	6,034	8,771	13,323	40,905	70,349	37,535	28,702	14,010	8,814	10,985	8,802	2,364	335,418
Masr El Gadida	8,832	11,605	35,037	22,522	2,770	13,289	19,325	28,964	48,025	38,144	126,236	117,982	51,622	32,919	11,743	20,440	8,648	623,726
Nasr City	6,044	10,966	35,881	19,481	2,523	10,667	21,129	27,590	56,449	28,834	118,213	256,811	44,359	42,546	9,960	19,504	30,701	760,618
Ain Shams	2,542	3,731	13,941	7,612	703	3,772	5,122	8,270	21,943	14,008	51,224	43,639	45,089	21,957	6,614	11,781	3,832	279,105
Salam City	1,313	2,395	10,653	5,665	489	2,601	3,759	6,092	17,843	8,289	32,249	39,093	21,797	51,787	6,369	18,898	3,479	241,185
Shoubra El Khima	6,725	4,770	19,868	10,903	1,063	4,392	5,762	8,343	26,169	23,142	25,623	18,960	13,361	9,054	17,663	11,589	4,059	256,541
Qalioub	3,851	6,321	8,975	5,309	449	1,863	2,679	3,080	11,612	11,129	11,990	9,960	6,874	6,630	83,392	15,177	2,979	209,933
Qanater	1,694	2,254	9,374	5,143	482	2,693	3,396	4,311	13,860	8,871	21,134	19,503	11,861	19,212	15,177	123,405	5,097	279,056
10th of Ramadan	2,531	1,413	3,553	1,674	331	1,454	1,149	1,797	7,067	2,558	8,645	30,654	4,511	4,833	2,871	4,919	35,756	119,593
Total	283,549	333,495	586,123	563,086	132,460	287,713	288,805	303,768	570,350	337,496	622,457	754,763	282,404	251,888	208,875	276,748	117,541	6,457,141

OD Matrix for Passenger Car 2005

	6th of October	Imbaba Markaz	Dokki	Giza	South Giza	Helwan	Maadi	Khaleefa	CBD	Shoubra	Masr El Gadida	Nasr City	Ain Shams	Salam City	Shoubra El Khima	Qalioub	Qanater	10th of Ramadan	Total
6th of October	1,997	215	472	1,165	95	52	159	176	273	89	113	97	37	24	51	24	13	1	5,053
Imbaba Markaz	215	25,703	20,607	14,533	1,010	1,108	3,010	3,902	10,840	4,570	4,812	3,541	2,498	2,396	4,100	4,419	2,275	79	109,618
Dokki	472	20,607	56,498	33,626	4,085	4,108	10,184	13,241	28,546	14,431	14,476	9,966	6,425	4,631	10,026	5,778	4,071	213	241,384
Giza	1,165	14,534	33,626	62,560	8,111	4,709	12,187	14,519	20,364	7,449	9,115	7,131	3,485	2,214	4,079	2,052	1,367	92	208,759
South Giza	95	1,010	4,085	8,111	14,311	4,065	2,008	1,914	2,693	826	1,137	948	359	232	471	185	113	8	42,571
Helwan	52	1,108	4,109	4,709	4,065	47,937	11,498	4,429	7,010	2,419	4,698	4,921	1,678	1,092	1,054	371	543	47	101,740
Maadi	159	3,010	10,184	12,187	2,008	11,498	29,649	11,266	14,986	4,493	8,276	7,756	2,861	1,853	2,042	967	1,166	100	124,461
Khaleefa	176	3,902	13,241	14,519	1,914	4,430	11,267	12,891	14,073	5,875	10,179	8,849	3,992	2,681	2,894	941	1,089	66	112,979
CBD	273	10,840	28,546	20,364	2,692	7,010	14,987	14,074	22,782	19,785	21,510	16,202	10,857	7,133	10,950	4,087	3,843	136	216,071
Shoubra	89	4,570	14,431	7,449	826	2,419	4,493	5,875	19,784	20,025	16,783	10,192	7,564	4,590	9,413	3,827	3,055	132	135,517
Masr El Gadida	113	4,813	14,476	9,115	1,137	4,698	8,276	10,179	21,510	16,783	42,147	28,467	20,079	11,945	10,185	4,042	6,132	493	214,590
Nasr City	97	3,541	9,966	7,131	948	4,921	7,756	8,849	16,201	10,192	28,467	43,828	14,485	12,729	6,829	3,550	6,447	2,110	188,047
Ain Shams	37	2,498	6,425	3,485	359	1,677	2,861	3,992	10,857	7,564	20,079	14,485	17,001	9,024	5,976	3,116	4,876	285	114,597
Salam City	24	2,396	4,631	2,214	232	1,092	1,854	2,681	7,133	4,590	11,945	12,729	9,024	14,778	5,568	4,611	8,131	413	94,046
Shoubra El Khima	51	4,100	10,026	4,079	471	1,054	2,042	2,894	10,950	9,413	10,185	6,829	5,976	5,568	17,967	6,682	6,094	191	104,572
Qalioub	24	4,420	5,778	2,052	185	371	967	941	4,088	3,827	4,041	3,550	3,116	4,611	6,683	22,155	5,030	126	71,965
Qanater	13	2,275	4,071	1,367	113	543	1,166	1,088	3,843	3,055	6,130	6,447	4,876	8,132	6,094	5,029	29,805	470	84,517
10th of Ramadan	1	79	213	92	8	47	100	66	136	132	493	2,110	285	413	191	126	470	-	4,962
Total	5,053	109,621	241,385	208,758	42,570	101,739	124,464	112,977	216,069	135,518	214,586	188,048	114,598	94,046	104,573	71,962	84,520	4,962	2,175,449

OD Matrix for Passenger Car 2012

	6th of October	Imbaba Markaz	Dokki	Giza	South Giza	Helwan	Maadi	Khaleefa	CBD	Shoubra	Masr El Gadida	Nasr City	Ain Shams	Salam City	Shoubra El Khima	Qalioub	Qanater	10th of Ramadan	Total
6th of October	21,212	4,151	6,386	17,483	1,247	1,108	1,608	2,618	5,114	1,330	1,473	982	684	471	1,011	729	443	13	68,063
Imbaba Markaz	4,151	61,759	27,722	16,718	1,157	1,719	3,401	4,965	14,079	4,676	7,061	5,779	2,071	1,348	2,828	2,947	911	153	163,445
Dokki	6,386	27,722	72,910	39,307	4,154	7,029	12,516	16,028	34,768	15,790	21,293	16,778	7,707	5,419	10,552	6,329	4,550	565	309,803
Giza	17,483	16,717	39,307	89,254	9,994	5,993	12,787	17,479	27,466	9,312	12,722	10,639	4,262	3,080	5,716	3,420	2,244	395	288,270
South Giza	1,247	1,157	4,154	28,085	4,329	2,126	3,847	1,086	3,847	1,086	1,810	1,557	505	354	627	336	218	40	63,821
Helwan	1,108	1,719	7,029	67,824	4,328	6,824	14,456	5,107	8,988	2,818	5,692	4,309	1,769	1,251	1,951	1,137	843	149	136,471
Maadi	1,608	3,401	12,516	12,787	2,126	14,456	42,105	13,824	18,351	5,685	11,615	9,549	3,119	2,323	3,281	2,039	1,550	298	160,633
Khaleefa	2,618	4,965	16,028	17,478	2,349	5,107	13,824	18,924	18,645	8,251	15,043	14,521	4,520	3,358	4,356	2,004	1,683	272	153,946
CBD	5,115	14,079	34,767	27,467	3,847	8,987	18,350	18,646	29,367	23,506	27,709	26,643	12,364	9,218	13,500	6,671	5,871	392	286,499
Shoubra	1,330	4,675	15,790	9,312	1,086	2,818	5,685	8,251	23,506	32,165	21,444	15,730	8,877	5,271	11,757	5,950	4,393	388	178,428
Masr El Gadida	1,473	7,060	21,294	12,721	1,810	5,692	11,615	15,043	27,709	21,444	69,267	56,592	28,393	19,671	14,616	6,566	10,060	1,375	332,401
Nasr City	982	5,780	16,778	10,639	1,557	4,309	9,549	14,521	26,644	15,728	56,591	103,996	22,444	21,402	11,419	5,475	9,103	7,641	344,558
Ain Shams	684	2,071	7,707	4,262	505	1,769	3,119	4,520	12,364	8,877	28,393	22,444	22,215	12,189	8,080	3,635	5,947	1,595	150,376
Salam City	471	1,347	5,419	3,080	354	1,251	2,323	3,358	9,218	5,271	19,671	21,402	12,189	24,876	5,886	4,033	8,484	1,397	130,030
Shoubra El Khima	1,011	2,828	10,552	5,716	627	1,951	3,281	4,356	13,500	11,757	14,616	11,419	8,080	5,886	19,080	9,462	6,629	493	131,244
Qalioub	729	2,947	6,329	3,420	336	1,137	2,039	2,004	6,671	5,950	6,566	5,476	3,635	4,033	9,462	31,891	5,430	178	98,233
Qanater	443	911	4,550	2,243	218	843	1,551	1,683	5,871	4,393	10,058	9,103	5,947	8,485	6,629	5,431	57,537	715	126,611
10th of Ramadan	13	153	565	395	40	149	298	272	392	388	1,375	7,641	1,595	1,397	493	178	715	17,276	33,335
Total	68,064	163,442	309,803	288,269	63,820	136,471	160,633	153,948	286,500	178,427	332,399	344,560	150,376	130,032	131,244	98,233	126,611	33,335	3,156,167

OD Matrix for Passenger Car 2022

	6th of October	Imbaba Markaz	Dokki	Giza	South Giza	Helwan	Maadi	Khaleefa	CBD	Shoubra	Masr El Gadida	Nasr City	Ain Shams Salam City	Shoubra El Khima	Qalioub	Qanater	10th of Ramadan	Total
6th of October	22,432	20,126	18,070	58,964	4,583	4,158	8,256	14,655	21,844	5,680	7,224	4,324	1,858	1,162	1,754	1,322	102	201,641
Imbaba Markaz	20,126	86,037	39,772	23,934	1,251	2,670	4,428	7,066	20,662	6,819	9,784	9,441	3,057	2,083	5,088	1,495	379	247,974
Dokki	18,070	39,772	101,483	54,655	5,280	11,273	16,341	21,629	48,549	22,469	28,651	30,589	11,562	8,878	7,467	7,557	2,230	450,873
Giza	58,964	23,935	54,655	122,354	12,050	7,631	13,868	22,238	37,485	12,379	18,218	15,524	6,349	4,720	4,320	3,795	894	427,725
South Giza	4,583	1,251	5,280	12,050	52,093	7,323	2,041	2,358	4,656	1,225	2,172	1,810	642	441	356	314	63	99,498
Helwan	4,158	2,671	11,273	7,631	7,323	106,628	16,660	7,571	15,653	5,036	10,424	8,287	3,118	2,250	1,575	1,704	364	215,707
Maadi	8,256	4,428	16,341	13,868	2,041	16,660	63,167	17,859	22,704	7,290	15,363	16,668	4,211	3,213	2,326	2,454	597	222,069
Khaleefa	14,655	7,066	21,630	22,238	2,358	7,570	17,859	32,046	27,909	10,761	21,185	22,426	6,624	5,140	2,659	3,222	1,062	233,091
CBD	21,844	20,664	48,549	37,485	4,656	15,653	22,705	27,911	46,626	32,076	37,394	47,822	17,631	14,921	9,021	10,964	3,964	440,366
Shoubra	5,680	6,819	22,469	12,379	1,225	5,036	7,290	10,762	32,075	52,982	29,715	23,822	11,284	6,830	8,660	6,260	1,070	261,971
Masr El Gadida	7,224	9,784	28,652	18,218	2,172	10,424	15,363	21,185	37,394	29,715	98,045	95,291	40,034	19,905	9,115	15,862	5,237	489,527
Nasr City	4,324	9,440	30,589	15,523	1,810	8,287	16,668	22,426	47,822	23,822	95,291	200,028	35,610	15,125	7,096	14,967	22,379	603,397
Ain Shams	1,858	3,057	11,562	6,349	642	3,118	4,211	6,624	17,631	11,283	40,034	35,610	33,775	17,090	5,279	9,173	2,439	220,148
Salam City	1,162	2,083	8,878	4,720	441	2,250	3,213	5,141	14,921	6,830	17,090	32,190	17,090	38,787	5,245	14,928	2,702	193,217
Shoubra El Khima	5,127	3,882	14,418	8,346	840	3,381	4,623	6,681	20,480	17,613	19,905	15,125	10,413	26,275	13,578	8,204	686	186,306
Qalioub	1,754	5,088	7,467	4,320	356	1,575	2,326	2,659	9,021	8,660	9,115	7,096	5,279	62,985	10,509	330	330	157,363
Qanater	1,322	1,494	7,557	3,795	314	1,704	2,454	3,222	10,965	6,260	15,861	14,967	9,173	14,928	84,272	1,855	1,855	198,856
10th of Ramadan	102	379	2,230	894	63	364	597	1,062	3,964	1,070	5,237	22,379	2,439	686	330	1,855	22,160	68,513
Total	201,641	247,976	450,875	427,723	99,498	215,705	222,070	233,095	440,361	261,970	489,525	603,399	220,149	186,306	157,363	198,857	68,513	4,918,242

OD Matrix for Taxi 2005

	6th of October	Imbaba Markaz	Dokki	Giza	South Giza	Helwan	Maadi	Khaleefa	CBD	Shoubra	Masr El Gadida	Nasr City	Ain Shams Salam City	Shoubra El Khima	Qalioub	Qanater	10th of Ramadan	Total
6th of October	698	48	89	285	14	5	25	19	23	7	6	5	3	1	2	1	-	1,240
Imbaba Markaz	48	10,859	6,109	4,617	184	175	627	887	2,431	1,124	990	618	576	570	1,233	519	12	32,836
Dokki	89	6,109	17,917	8,903	812	723	2,137	2,948	5,725	3,528	2,749	1,554	1,403	987	1,254	800	27	60,425
Giza	285	4,617	8,903	20,110	2,363	981	3,075	3,724	3,962	1,805	1,706	1,167	755	455	377	240	11	55,642
South Giza	14	184	812	2,363	5,547	1,094	402	321	345	117	113	88	47	26	16	10	-	11,581
Helwan	5	175	723	981	1,094	16,976	3,188	938	1,102	458	836	947	335	209	32	65	7	28,293
Maadi	25	627	2,138	3,075	402	3,188	9,412	2,965	2,823	928	1,733	1,586	606	353	113	164	10	30,612
Khaleefa	19	887	2,948	3,724	321	938	2,965	3,792	2,868	1,302	2,204	1,711	896	551	104	161	9	26,155
CBD	23	2,432	5,726	3,962	345	1,102	2,823	2,868	5,876	4,673	3,948	2,367	2,268	1,424	691	662	14	44,142
Shoubra	7	1,124	3,528	1,805	117	458	928	1,302	4,673	6,793	4,431	2,166	2,147	1,157	887	636	21	35,279
Masr El Gadida	6	990	2,749	1,706	113	836	1,733	2,204	3,949	4,431	11,066	6,092	5,784	3,190	751	1,327	106	49,979
Nasr City	5	618	1,554	1,167	88	947	1,586	1,711	2,367	2,166	6,092	10,516	3,584	3,182	622	1,418	455	39,786
Ain Shams	3	576	1,403	755	47	335	606	896	2,268	2,147	5,784	3,584	6,142	2,867	758	1,316	70	31,487
Salam City	1	570	987	455	26	209	353	551	1,424	1,157	3,190	3,182	2,867	5,398	1,308	2,580	105	26,125
Shoubra El Khima	9	1,257	2,760	1,106	82	222	464	755	2,938	3,099	2,946	1,708	1,930	1,762	2,240	1,971	53	32,932
Qalioub	2	1,233	1,254	377	16	32	113	104	691	887	751	622	758	1,308	8,194	1,400	29	20,011
Qanater	1	519	800	240	10	65	164	161	662	636	1,327	1,418	1,316	1,400	11,458	152	152	24,880
10th of Ramadan	-	12	27	11	-	7	10	9	14	21	106	455	70	105	29	152	6,905	7,986
Total	1,240	32,837	60,427	55,642	11,581	28,293	30,611	26,155	44,141	35,279	49,978	39,786	31,487	26,125	20,011	24,880	7,986	559,391

OD Matrix for Taxi 2012

	6th of October	Imbaba Markaz	Dokki	Giza	South Giza	Helwan	Maadi	Khaleefa	CBD	Shoubra	Masr El Gadida	Nasr City	Ain Shams Salam City	Shoubra El Khima	Qalioub	Qanater	10th of Ramadan	Total
6th of October	5,448	929	1,172	4,073	272	192	274	428	721	216	204	118	96	65	172	51	-	14,533
Imbaba Markaz	929	22,743	7,642	4,771	193	283	618	1,060	2,976	979	1,413	948	377	217	677	135	34	46,735
Dokki	1,172	7,642	22,939	9,956	762	1,293	2,507	3,443	6,940	3,589	4,128	2,626	1,606	1,088	2,681	844	138	74,643
Giza	4,073	4,773	9,956	28,197	2,812	1,151	2,904	4,157	5,195	2,001	2,210	1,548	838	592	1,417	378	121	72,961
South Giza	272	193	762	2,812	9,568	1,064	364	402	536	153	216	159	64	47	109	25	6	16,786
Helwan	192	283	1,293	1,149	1,064	22,619	3,750	945	1,387	461	910	595	295	198	417	110	37	35,848
Maadi	274	618	2,507	2,903	364	3,750	12,950	3,450	3,371	1,124	2,307	1,650	582	411	731	206	58	37,547
Khaleefa	428	1,060	3,444	4,157	402	945	3,450	5,684	3,823	1,794	3,190	2,649	897	639	1,082	256	63	34,242
CBD	721	2,976	6,940	5,195	536	1,387	3,371	3,824	7,952	5,311	4,960	3,718	2,431	1,801	3,328	1,047	77	56,756
Shoubra	216	979	3,589	2,001	153	461	1,124	1,794	5,311	10,502	5,268	3,163	2,272	1,217	3,536	983	90	44,036
Masr El Gadida	204	1,413	4,128	2,210	216	910	2,307	3,191	4,960	5,268	18,066	11,770	7,731	5,118	3,988	2,331	387	75,458
Nasr City	118	949	2,628	1,548	158	595	1,650	2,649	3,718	3,163	11,769	26,046	5,148	5,012	2,722	1,899	2,089	72,729
Ain Shams	96	377	1,606	838	64	295	582	897	2,431	2,272	7,731	5,148	7,529	3,575	2,407	1,551	574	38,802
Salam City	65	217	1,088	592	47	198	411	639	1,801	1,217	5,118	5,012	3,575	8,514	1,626	2,435	442	33,988
Shoubra El Khima	172	677	2,681	1,417	109	417	731	1,082	3,328	3,536	3,988	2,722	2,407	1,626	2,929	1,948	150	42,013
Qalioub	102	740	1,289	638	34	143	291	279	1,181	1,377	1,260	868	829	11,219	1,460	40	40	25,670
Qanater	51	135	844	378	24	110	205	256	1,047	983	2,331	1,899	1,551	1,460	19,898	187	187	35,742
10th of Ramadan	-	34	138	121	6	37	58	63	77	90	387	2,089	574	442	40	187	16,926	21,419
Total	14,533	46,738	74,646	72,956	16,784	35,850	37,547	34,243	56,755	44,036	75,456	72,728	38,802	33,988	42,013	35,744	21,419	779,908

OD Matrix for Taxi 2022

	6th of October	Imbaba Markaz	Dokki	Giza	South Giza	Helwan	Maadi	Khaleefa	CBD	Shoubra	Masr El Gadida	Nasr City	Ain Shams Salam City	Shoubra El Khima	Qalioub	Qanater	10th of Ramadan	Total
6th of October	17,547	3,982	2,857	13,696	895	536	1,143	2,229	2,905	772	965	519	246	149	217	149	8	49,586
Imbaba Markaz	3,982	31,242	9,490	5,920	155	379	718	1,260	3,666	1,209	1,634	1,356	485	300	1,101	194	67	63,929
Dokki	2,857	9,490	29,215	12,507	817	1,913	2,965	4,196	8,997	4,597	5,041	4,787	2,178	1,668	1,293	1,341	522	97,613
Giza	13,696	5,921	12,507	36,035	3,101	1,329	2,745	4,685	6,238	2,368	2,885	2,270	1,171	898	709	653	227	99,358
South Giza	895	155	817	3,101	14,947	1,542	271	298	521	131	200	168	61	48	29	26	8	23,336
Helwan	536	379	1,913	1,329	31,760	3,821	3,821	1,327	2,313	773	1,636	1,202	475	638	178	226	69	50,456
Maadi	1,143	718	2,965	2,745	271	3,821	17,710	4,023	3,888	1,291	2,740	2,849	721	955	294	344	116	47,121
Khaleefa	2,229	1,260	4,196	4,685	298	1,327	4,023	8,862	5,299	1,991	4,040	3,823	1,173	1,507	335	503	241	46,705
CBD	2,905	3,666	8,997	6,238	521	2,313	3,888	5,299	12,164	6,386	6,334	7,114	3,121	4,529	1,443	1,897	865	80,356
Shoubra	772	1,209	4,597	2,368	131	773	1,291	1,991	6,386	15,379	6,375	4,247	2,448	4,603	1,787	1,187	233	57,098
Masr El Gadida	965	1,633	5,041	2,885	200	1,636	2,740	4,040	6,334	6,376	23,251	19,260	9,634	4,736	1,595	3,394	1,496	101,126
Nasr City	519	1,356	4,787	2,270	168	1,202	2,849	3,823	7,114	4,247	19,260	47,243	7,306	3,018	2,956	2,956	5,447	121,053
Ain Shams	246	485	2,178	1,171	61	475	721	1,173	3,121	2,448	9,634	7,306	10,104	2,640	1,079	2,143	705	50,028
Salam City	149	300	1,668	898	48	339	527	913	2,676	1,321	5,909	6,517	4,338	1,570	1,063	3,650	644	44,355
Shoubra El Khima	771	771	3,229	1,920	118	638	955	1,507	4,530	4,603	4,736	3,018	2,640	15,934	3,606	2,021	164	52,731
Qalioub	217	1,101	1,293	709	29	178	294	335	1,443	1,787	1,595	971	1,079	3,606	2,458	49	36,611	
Qanater	149	194	1,340	653	26	226	343	503	1,897	1,187	3,394	2,956	2,143	2,458	30,629	425	54,194	
10th of Ramadan	8	67	522	227	8	69	116	241	865	233	1,496	5,447	705	49	425	10,910	22,196	
Total	49,586	63,929	97,612	99,357	23,336	50,456	47,120	46,705	80,357	57,099	101,125	121,053	50,028	44,356	36,611	54,196	22,196	1,097,852

OD Matrix for Special Bus 2005

	6th of October	Imbaba Markaz	Dokki	Giza	South Giza	Helwan	Maadi	Khaleefa	CBD	Shoubra	Masr El Gadida	Nasr City	Ain Shams	Salam City	Shoubra El Khima	Qalioub	Qanater	10th of Ramadan	Total	
6th of October	87	2	5	24	-	-	-	-	-	-	-	-	-	-	-	-	-	-	-	118
Imbaba Markaz	2	1,276	581	479	10	5	43	55	141	80	58	32	38	40	120	95	39	-	-	3,094
Dokki	5	581	1,552	853	48	36	148	177	246	278	153	58	98	69	293	94	51	1	1	4,741
Giza	24	479	853	2,131	218	61	275	269	180	147	98	51	56	33	104	22	13	1	1	5,015
South Giza	-	10	48	218	646	105	18	15	9	2	2	1	1	-	5	-	-	-	-	1,080
Helwan	-	5	36	61	105	2,137	327	52	38	24	36	67	22	14	17	-	3	-	-	2,944
Maadi	-	43	148	275	18	327	1,018	234	135	54	116	116	43	22	35	-	5	-	-	2,589
Khaleefa	-	55	177	269	15	52	234	218	55	70	110	74	54	29	51	-	6	-	-	1,469
CBD	-	141	246	180	9	38	135	55	17	238	106	36	121	68	232	29	37	-	-	1,688
Shoubra	-	80	278	147	2	24	54	70	238	660	365	141	197	97	345	51	48	1	1	2,798
Masr El Gadida	-	58	153	98	2	36	116	110	106	365	854	400	556	278	298	35	96	9	9	3,570
Nasr City	-	32	58	51	1	67	116	74	36	141	400	786	289	255	161	35	119	50	50	2,671
Ain Shams	-	38	98	56	1	22	43	54	121	197	556	289	689	302	216	49	114	6	6	2,851
Salam City	-	40	69	33	-	14	22	29	68	97	278	255	302	618	203	109	250	9	9	2,396
Shoubra El Khima	-	120	293	104	5	17	35	51	232	345	298	161	216	203	1,090	237	205	6	6	3,618
Qalioub	-	95	94	22	-	-	-	-	29	51	35	35	49	109	237	874	118	1	1	1,749
Qanater	-	39	51	13	-	3	5	6	37	48	96	119	114	250	205	118	1,269	21	21	2,394
10th of Ramadan	-	-	1	1	-	-	-	-	-	1	9	50	6	9	6	1	21	803	803	908
Total	118	3,094	4,741	5,015	1,080	2,944	2,589	1,469	1,688	2,798	3,570	2,671	2,851	2,396	3,618	1,749	2,394	908	908	45,693

OD Matrix for Special Bus 2012

	6th of October	Imbaba Markaz	Dokki	Giza	South Giza	Helwan	Maaadi	Khaleefa	CBD	Shoubra	Masr El Gadida	Nasr City	Ain Shams	Salam City	Shoubra El Khima	Qalioub	Qanater	10th of Ramadan	Total
6th of October	2,049	59	84	392	18	10	15	19	28	11	10	3	4	3	12	4	2	-	2,723
Imbaba Markaz	59	2,478	619	373	10	15	31	51	138	50	82	39	15	9	40	52	3	-	4,064
Dokki	84	619	1,908	847	42	85	167	197	291	241	237	98	113	63	227	85	50	5	5,359
Giza	392	373	847	2,791	228	59	202	274	217	131	94	45	49	32	116	37	21	5	5,913
South Giza	18	10	42	228	1,049	80	14	16	15	3	3	1	-	-	5	1	1	-	1,486
Helwan	10	15	85	59	80	2,513	346	44	56	18	35	17	13	9	32	5	3	1	3,341
Maaadi	15	31	167	202	14	346	1,291	253	156	54	128	73	26	17	62	11	8	-	2,854
Khaleefa	19	51	197	274	16	44	253	358	66	73	145	113	37	25	71	8	13	-	1,763
CBD	28	138	291	217	15	56	156	66	67	262	101	45	114	80	233	52	51	-	1,972
Shoubra	11	50	241	131	3	18	54	73	262	992	362	181	170	72	326	78	62	3	3,089
Masr El Gadida	10	82	237	94	3	35	128	145	101	362	1,331	748	676	426	336	60	138	18	4,930
Nasr City	3	39	98	45	1	17	73	113	45	181	748	2,194	369	350	207	33	113	143	4,772
Ain Shams	4	15	113	49	-	13	26	37	114	170	676	369	794	327	227	48	114	47	3,143
Salam City	3	9	63	32	-	9	17	25	80	72	426	350	327	900	139	67	203	30	2,752
Shoubra El Khima	12	40	227	116	5	32	62	71	233	326	336	207	227	139	1,564	284	164	8	4,053
Qalioub	4	52	85	37	1	5	11	8	52	78	60	33	48	67	284	1,186	105	-	2,116
Qanater	2	3	50	21	1	3	8	13	51	62	138	113	114	203	164	105	2,116	10	3,177
10th of Ramadan	-	-	5	5	-	1	-	-	-	3	18	143	47	30	8	-	10	1,695	1,965
Total	2,723	4,064	5,359	5,913	1,486	3,341	2,854	1,763	1,972	3,089	4,930	4,772	3,143	2,752	4,053	2,116	3,177	1,965	59,472

OD Matrix for Special Bus 2022

	6th of October	Imbaba Markaz	Dokki	Giza	South Giza	Helwan	Maadi	Khaleefa	CBD	Shoubra	Masr El Gadida	Nasr City	Ain Shams	Salam City	Shoubra El Khima	Qalioub	Qanater	10th of Ramadan	Total
6th of October	4,012	253	141	1,008	51	19	38	92	77	29	36	9	5	2	32	5	3	-	5,812
Imbaba Markaz	253	3,200	714	436	3	18	31	56	148	58	80	49	18	12	41	74	6	2	5,199
Dokki	141	714	2,277	1,009	30	156	180	218	353	314	281	214	153	107	264	68	78	25	6,582
Giza	1,008	436	1,009	3,380	232	82	165	297	234	147	118	83	66	47	148	34	34	11	7,531
South Giza	51	3	30	232	1,504	99	8	7	9	2	2	-	-	-	5	-	-	-	1,952
Helwan	19	18	156	82	99	3,375	340	92	146	45	92	49	24	12	50	8	7	2	4,616
Maadi	38	31	180	165	8	340	1,688	296	175	68	151	140	33	19	81	8	16	3	3,440
Khaleefa	92	56	218	297	7	92	296	617	97	77	184	176	59	38	97	8	22	7	2,440
CBD	77	148	353	234	9	146	175	97	112	293	126	201	139	120	265	46	82	25	2,648
Shoubra	29	58	314	147	2	45	68	77	293	1,407	404	207	164	65	391	95	62	7	3,835
Masr El Gadida	36	80	281	118	2	92	151	184	126	404	1,636	1,269	788	433	363	74	200	88	6,325
Nasr City	9	49	214	83	-	49	140	176	201	207	1,269	4,041	487	386	195	23	163	329	8,021
Ain Shams	5	18	153	66	-	24	33	59	139	164	788	487	999	369	215	56	147	47	3,769
Salam City	2	12	107	47	-	12	19	38	120	65	433	386	369	1,175	115	61	270	36	3,267
Shoubra El Khima	32	41	264	148	5	50	81	97	265	391	363	195	215	115	2,004	309	142	8	4,725
Qalioub	5	74	68	34	-	8	8	8	46	95	74	23	56	61	309	1,795	163	-	2,827
Qanater	3	6	78	34	-	7	16	22	82	62	200	163	147	270	142	163	3,201	23	4,619
10th of Ramadan	-	2	25	11	-	2	3	7	25	7	88	329	47	36	8	-	23	2,394	3,007
Total	5,812	5,199	6,582	7,531	1,952	4,616	3,440	2,440	2,648	3,835	6,325	8,021	3,769	3,267	4,725	2,827	4,619	3,007	80,615

OD Matrix for Truck 2005

	6th of October	Imbaba Markaz	Dokki	Giza	South Giza	Helwan	Maaadi	Khaleefa	CBD	Shoubra	Masr El Gadida	Nasr City	Ain Shams	Salam City	Shoubra El Khima	Qalioub	Qanater	10th of Ramadan	Total
6th of October	-	753	634	620	102	178	193	524	1,849	559	314	559	152	349	246	68	94	-	7,194
Imbaba Markaz	753	655	1,561	1,121	145	136	194	366	1,427	445	79	131	237	543	67	87	368	438	8,753
Dokki	634	1,561	2,740	2,896	426	692	501	1,262	3,216	659	507	447	81	148	498	185	256	277	16,986
Giza	620	1,121	2,896	5,827	834	606	1,124	2,120	2,643	290	883	1,289	55	147	601	319	325	308	22,008
South Giza	102	145	426	834	626	942	237	500	318	10	330	890	-	8	116	81	110	166	5,841
Helwan	178	136	692	606	942	2,166	2,198	928	2,140	256	924	1,893	438	521	204	122	230	574	15,148
Maaadi	193	194	501	1,124	237	2,198	2,752	1,690	1,267	231	1,303	1,617	262	334	133	63	202	246	14,547
Khaleefa	524	366	1,262	2,120	500	928	1,690	2,369	3,487	750	1,688	1,366	889	437	93	100	329	270	19,168
CBD	1,849	1,427	3,216	2,643	318	2,140	1,267	3,487	12,431	3,088	4,299	1,816	1,303	851	1,038	1,132	548	546	43,399
Shoubra	559	445	659	290	10	256	231	750	3,088	677	1,564	1,010	243	707	649	370	561	498	12,567
Masr El Gadida	314	79	507	883	330	924	1,303	1,688	4,299	1,564	2,489	2,124	613	926	567	394	484	717	20,205
Nasr City	559	131	447	1,289	890	1,893	1,617	1,366	1,816	1,010	2,124	2,651	952	584	819	418	600	390	19,556
Ain Shams	152	237	81	55	-	438	262	889	1,303	243	613	952	292	554	117	-	91	467	6,746
Salam City	349	543	148	147	8	521	334	437	851	707	926	584	554	941	123	318	177	557	8,225
Shoubra El Khima	246	67	498	601	116	204	133	93	1,038	649	567	819	117	123	549	79	193	148	6,240
Qalioub	68	87	185	319	81	122	63	100	1,132	370	394	418	-	318	79	331	345	251	4,663
Qanater	94	368	256	325	110	230	202	329	548	561	484	600	91	177	193	345	539	198	5,650
10th of Ramadan	-	438	277	308	166	574	246	270	546	498	717	390	467	557	148	251	198	87	6,138
Total	7,194	8,753	16,986	22,008	5,841	15,148	14,547	19,168	43,399	12,567	20,205	19,556	6,746	8,225	6,240	4,663	5,650	6,138	243,034

OD Matrix for Truck 2012

	6th of October	Imbaba Markaz	Dokki	Giza	South Giza	Helwan	Maaadi	Khaleefa	CBD	Shoubra	Masr El Gadida	Nasr City	Ain Shams	Salam City	Shoubra El Khima	Qalioub	Qanater	10th of Ramadan	Total
6th of October	1,116	2,370	2,722	1,538	84	163	170	451	1,590	465	322	687	344	287	434	1,133	95	1,433	15,404
Imbaba Markaz	2,370	425	3,346	1,850	120	145	138	267	1,381	369	69	75	211	432	47	44	292	679	12,260
Dokki	2,722	3,346	3,865	3,330	279	458	332	858	2,623	1,551	792	214	215	385	1,524	116	208	568	23,386
Giza	1,538	1,850	3,330	5,301	565	596	745	1,738	1,697	333	941	1,251	39	86	372	198	315	370	21,265
South Giza	84	120	279	565	428	1,916	343	557	342	6	290	425	2	7	73	50	82	182	5,751
Helwan	163	145	458	596	1,916	1,949	3,341	1,275	1,367	167	840	854	254	326	255	79	280	753	15,018
Maaadi	170	138	332	745	343	3,341	3,051	1,282	851	151	786	1,100	177	210	78	40	226	295	13,316
Khaleefa	451	267	858	1,738	557	1,275	1,282	1,633	3,436	507	2,727	932	574	294	48	63	280	316	17,238
CBD	1,590	1,381	2,623	1,697	342	1,367	851	3,436	11,727	2,408	3,084	1,012	1,111	621	668	856	458	1,549	36,781
Shoubra	465	369	1,551	333	6	167	151	507	2,408	670	1,214	431	164	756	409	492	681	946	11,720
Masr El Gadida	322	69	792	941	290	840	786	2,727	3,084	1,214	2,481	1,817	955	503	469	1,010	923	1,359	20,582
Nasr City	687	75	214	1,251	425	854	1,100	932	1,012	431	1,817	4,266	698	2,503	501	1,484	873	2,045	21,168
Ain Shams	344	211	215	39	2	254	177	574	1,138	164	955	698	186	372	73	364	257	940	6,963
Salam City	287	432	385	86	7	326	210	294	621	756	503	2,503	372	644	487	201	171	1,050	9,335
Shoubra El Khima	434	47	1,524	372	73	255	78	48	668	409	469	501	73	487	697	143	621	2,435	9,334
Qalioub	1,133	44	116	198	50	79	40	63	856	492	1,010	1,484	364	201	143	189	1,085	2,163	9,710
Qanater	95	292	208	315	82	280	226	280	458	681	923	873	257	171	621	1,085	1,836	810	9,493
10th of Ramadan	1,433	679	568	370	182	753	295	316	1,549	946	1,359	2,045	940	1,050	2,435	2,163	810	186	18,079
Total	15,404	12,260	23,386	21,265	5,751	15,018	13,316	17,238	36,808	11,720	20,582	21,168	6,936	9,335	9,334	9,710	9,493	18,079	276,803

OD Matrix for Truck 2022

	6th of October	Imbaba Markaz	Dokki	Giza	South Giza	Helwan	Maaadi	Khateefa	CBD	Shoubra	Masr El Gadida	Nasr City	Ain Shams	Salam City	Shoubra El Khima	Qalioub	Qanater	10th of Ramadan	Total
6th of October	3,163	3,788	4,782	2,655	150	309	315	811	2,759	808	600	1,189	623	513	795	1,875	220	2,421	27,776
Imbaba Markaz	3,788	671	4,330	2,429	161	200	189	362	1,859	482	106	119	272	543	76	58	560	965	17,170
Dokki	4,782	4,330	5,134	4,448	386	633	460	1,189	3,535	2,018	1,063	291	297	524	1,957	147	399	776	32,369
Giza	2,655	2,429	4,448	7,065	801	711	1,039	2,413	2,350	456	1,300	1,605	58	105	489	246	661	542	29,373
South Giza	150	161	386	801	595	2,583	433	723	478	10	396	545	4	11	100	64	142	260	7,842
Helwan	311	202	633	711	2,583	2,599	4,283	1,608	1,828	228	1,137	1,131	287	440	323	102	756	1,020	20,182
Maaadi	150	77	224	476	345	2,299	2,524	933	332	53	596	576	35	144	79	13	128	205	9,189
Khateefa	761	363	951	2,241	658	973	1,734	1,937	3,751	556	3,304	823	593	317	58	78	274	360	19,732
CBD	2,543	1,863	3,515	2,350	478	1,828	1,206	4,738	16,155	3,275	4,146	1,280	1,571	856	894	1,102	685	2,224	50,709
Shoubra	664	448	1,970	429	10	180	122	493	2,151	581	1,041	426	114	598	497	443	1,293	1,054	12,514
Masr El Gadida	607	108	1,063	1,301	396	1,137	1,071	3,555	4,171	1,649	3,304	2,162	1,166	669	619	959	984	1,827	26,748
Nasr City	1,192	121	291	1,605	545	1,129	1,472	1,165	1,312	558	2,393	5,499	956	3,453	622	1,870	1,418	2,546	28,147
Ain Shams	433	171	48	26	-	155	157	414	1,052	113	768	236	211	160	57	200	318	641	5,160
Salam City	-	-	-	-	-	-	-	-	126	73	-	-	-	-	-	-	50	97	346
Shoubra El Khima	795	76	1,957	489	100	323	103	58	894	535	619	622	93	640	882	170	1,222	3,201	12,779
Qalioub	1,875	58	147	246	64	102	51	78	1,102	587	1,206	1,870	460	261	170	208	2,047	2,600	13,132
Qanater	220	560	399	661	142	756	583	564	916	1,362	1,679	1,417	398	364	1,222	2,047	5,303	2,794	21,387
10th of Ramadan	2,421	965	776	542	260	1,019	433	487	2,213	1,248	1,824	2,499	1,320	1,451	3,019	2,492	2,616	292	25,877
Total	26,510	16,391	31,054	28,475	7,674	16,936	16,175	21,528	46,984	14,592	25,482	22,290	8,458	11,049	11,859	12,074	19,076	23,825	360,432

APPENDIX 5.3

TRIP-ENDS TABLE FOR ALL VEHICLE

Appendix 5-3

Trip-ends Table for All Vehicle

	Sector	2005	2012	2022	Growth Rate	
					2005-2012	2012-2022
1	6th of October	27,210	201,447	568,364	33.1%	10.9%
2	Imbaba Markaz	308,606	453,008	667,767	5.6%	4.0%
3	Dokki	647,075	826,385	1,173,560	3.6%	3.6%
4	Giza	582,847	776,812	1,127,073	4.2%	3.8%
5	South Giza	122,145	175,685	265,088	5.3%	4.2%
6	Helwan	296,249	381,358	578,674	3.7%	4.3%
7	Maadi	344,420	428,700	570,624	3.2%	2.9%
8	Khaleefa	319,540	414,381	605,736	3.8%	3.9%
9	CBD	610,597	764,043	1,144,429	3.3%	4.1%
10	Shoubra	372,323	474,545	672,914	3.5%	3.6%
11	Masr El Gadida	576,683	866,738	1,246,183	6.0%	3.7%
12	Nasr City	500,121	886,455	1,515,381	8.5%	5.5%
13	Ain Shams	311,363	398,541	561,509	3.6%	3.5%
14	Salam City	261,584	352,212	493,073	4.3%	3.4%
15	Shoubra El Khima	294,725	373,288	512,161	3.4%	3.2%
16	Qalioub	196,773	271,458	418,808	4.7%	4.4%
17	Qanater	234,885	350,048	555,804	5.9%	4.7%
18	10th of Ramadan	39,988	149,596	237,134	20.7%	4.7%
Total		6,047,134	8,544,700	12,914,282	5.1%	4.2%

Trip-ends Table for Passenger Car

	Sector	2005	2012	2022	Growth Rate	
					2005-2012	2012-2022
1	6th of October	10,106	136,127	403,282	45.0%	11.5%
2	Imbaba Markaz	219,239	326,887	495,950	5.9%	4.3%
3	Dokki	482,769	619,606	901,748	3.6%	3.8%
4	Giza	417,517	576,539	855,448	4.7%	4.0%
5	South Giza	85,141	127,641	198,996	6.0%	4.5%
6	Helwan	203,479	272,942	431,412	4.3%	4.7%
7	Maadi	248,925	321,266	444,139	3.7%	3.3%
8	Khaleefa	225,956	307,894	466,186	4.5%	4.2%
9	CBD	432,140	572,999	880,727	4.1%	4.4%
10	Shoubra	271,035	356,855	523,941	4.0%	3.9%
11	Masr El Gadida	429,176	664,800	979,052	6.5%	3.9%
12	Nasr City	376,095	689,118	1,206,796	9.0%	5.8%
13	Ain Shams	229,195	300,752	440,297	4.0%	3.9%
14	Salam City	188,092	260,062	386,433	4.7%	4.0%
15	Shoubra El Khima	209,145	262,488	372,612	3.3%	3.6%
16	Qalioub	143,927	196,466	314,726	4.5%	4.8%
17	Qanater	169,037	253,222	397,713	5.9%	4.6%
18	10th of Ramadan	9,924	66,670	137,026	31.3%	7.5%
Total		4,350,898	6,312,334	9,836,484	5.5%	4.5%

Trip-ends Table for Taxi

	Sector	2005	2012	2022	Growth Rate	
					2005-2012	2012-2022
1	6th of October	2,480	29,066	99,172	42.1%	13.1%
2	Imbaba Markaz	65,672	93,473	127,858	5.2%	3.2%
3	Dokki	120,850	149,289	195,225	3.1%	2.7%
4	Giza	111,284	145,917	198,715	3.9%	3.1%
5	South Giza	23,162	33,570	46,672	5.4%	3.4%
6	Helwan	56,586	71,698	100,912	3.4%	3.5%
7	Maadi	61,224	75,094	94,241	3.0%	2.3%
8	Khaleefa	52,310	68,485	93,410	3.9%	3.2%
9	CBD	88,284	113,511	160,713	3.7%	3.5%
10	Shoubra	70,558	88,072	114,197	3.2%	2.6%
11	Masr El Gadida	99,958	150,914	202,251	6.1%	3.0%
12	Nasr City	79,572	145,457	242,106	9.0%	5.2%
13	Ain Shams	62,974	77,604	100,056	3.0%	2.6%
14	Salam City	52,250	67,976	88,711	3.8%	2.7%
15	Shoubra El Khima	65,864	84,026	105,461	3.5%	2.3%
16	Qalioub	40,022	51,340	73,222	3.6%	3.6%
17	Qanater	49,760	71,486	108,390	5.3%	4.3%
18	10th of Ramadan	15,972	42,838	44,392	15.1%	0.4%
Total		1,118,782	1,559,816	2,195,704	4.9%	3.5%

Trip-ends Table for Special Bus (Company bus and Tourist bus)

	Sector	2005	2012	2022	Growth Rate	
					2005-2012	2012-2022
1	6th of October	236	5,446	11,624	56.6%	7.9%
2	Imbaba Markaz	6,188	8,128	10,398	4.0%	2.5%
3	Dokki	9,482	10,718	13,164	1.8%	2.1%
4	Giza	10,030	11,826	15,062	2.4%	2.4%
5	South Giza	2,160	2,972	3,904	4.7%	2.8%
6	Helwan	5,888	6,682	9,232	1.8%	3.3%
7	Maadi	5,178	5,708	6,880	1.4%	1.9%
8	Khaleefa	2,938	3,526	4,880	2.6%	3.3%
9	CBD	3,376	3,944	5,296	2.2%	3.0%
10	Shoubra	5,596	6,178	7,670	1.4%	2.2%
11	Masr El Gadida	7,140	9,860	12,650	4.7%	2.5%
12	Nasr City	5,342	9,544	16,042	8.6%	5.3%
13	Ain Shams	5,702	6,286	7,538	1.4%	1.8%
14	Salam City	4,792	5,504	6,534	2.0%	1.7%
15	Shoubra El Khima	7,236	8,106	9,450	1.6%	1.5%
16	Qalioub	3,498	4,232	5,654	2.8%	2.9%
17	Qanater	4,788	6,354	9,238	4.1%	3.8%
18	10th of Ramadan	1,816	3,930	6,014	11.7%	4.3%
Total		91,386	118,944	161,230	3.8%	3.1%

Trip-ends Table for Truck

	Sector	2005	2012	2022	Growth Rate	
					2005-2012	2012-2022
1	6th of October	14,388	30,808	54,286	11.5%	5.8%
2	Imbaba Markaz	17,506	24,520	33,561	4.9%	3.2%
3	Dokki	33,972	46,772	63,423	4.7%	3.1%
4	Giza	44,016	42,530	57,848	-0.5%	3.1%
5	South Giza	11,682	11,502	15,516	-0.2%	3.0%
6	Helwan	30,296	30,036	37,118	-0.1%	2.1%
7	Maadi	29,094	26,632	25,364	-1.3%	-0.5%
8	Khaleefa	38,336	34,476	41,260	-1.5%	1.8%
9	CBD	86,798	73,589	97,693	-2.3%	2.9%
10	Shoubra	25,134	23,440	27,106	-1.0%	1.5%
11	Masr El Gadida	40,410	41,164	52,230	0.3%	2.4%
12	Nasr City	39,112	42,336	50,437	1.1%	1.8%
13	Ain Shams	13,492	13,899	13,618	0.4%	-0.2%
14	Salam City	16,450	18,670	11,395	1.8%	-4.8%
15	Shoubra El Khima	12,480	18,668	24,638	5.9%	2.8%
16	Qalioub	9,326	19,420	25,206	11.0%	2.6%
17	Qanater	11,300	18,986	40,463	7.7%	7.9%
18	10th of Ramadan	12,276	36,158	49,702	16.7%	3.2%
	Total	486,068	553,606	720,864	1.9%	2.7%

APPENDIX 6.1

TYPICAL CROSS SECTIONS

APPENDIX 6.1 TYPICAL CROSS SECTIONS

Table A6.1–1 List of Typical Cross Sections

Type No.	Name	Fig. No.	Description (Usage)
1	Standard Viaduct	A6.1 – 1	Ordinary section
2	At-Grade	A6.1 – 2	In the vicinity of existing flyovers
3	Half-Underground	A6.1 – 3	Minimize obstruction of view
4	Separated Viaduct	A6.1 – 4	Where space is available on both sides of the existing carriageway and the space above the centerline of existing street need to be open
5	Gantry-Pier Viaduct	A6.1 – 5	Same as above; where expressway cannot be constructed on sidewalks
6	Single-Pier Double Deck	A6.1 – 6	Where ROW of the street is limited
7	Gantry-Pier Double-Deck	A6.1 – 7	Same as above; where piers cannot be constructed along the median of the street
8	Transition 1	A6.1 – 8	Transition between the Standard Viaduct (Type 1) and the At-Grade (Type 2)
9	Transition 2	A6.1 – 9	Transition between the At-Grade (Type 2) and Half-Underground (Type 3)
10	Ramp 1	A6.1 – 10	Ramp on Type 1 section
11	Ramp 2	A6.1 – 11	Ramp on Type 2 section

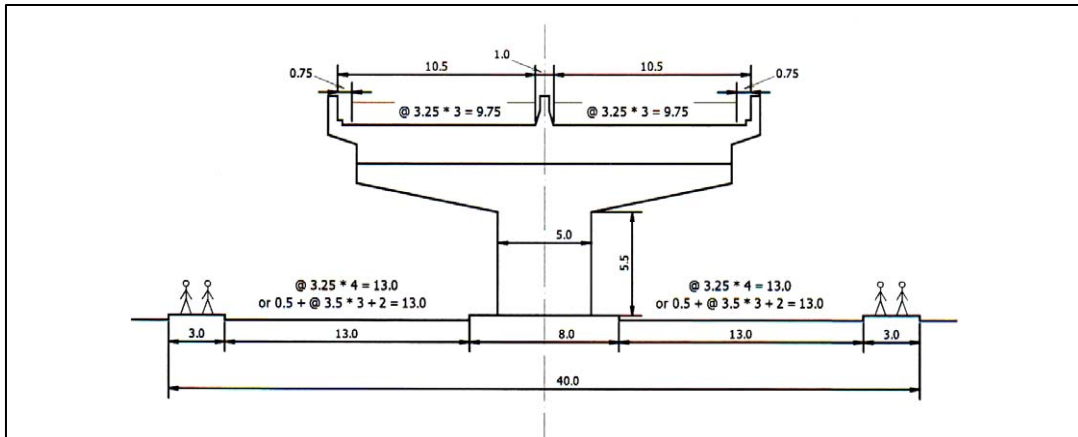

Figure A6.1-1 Typical Cross Section 1 (Standard Viaduct)

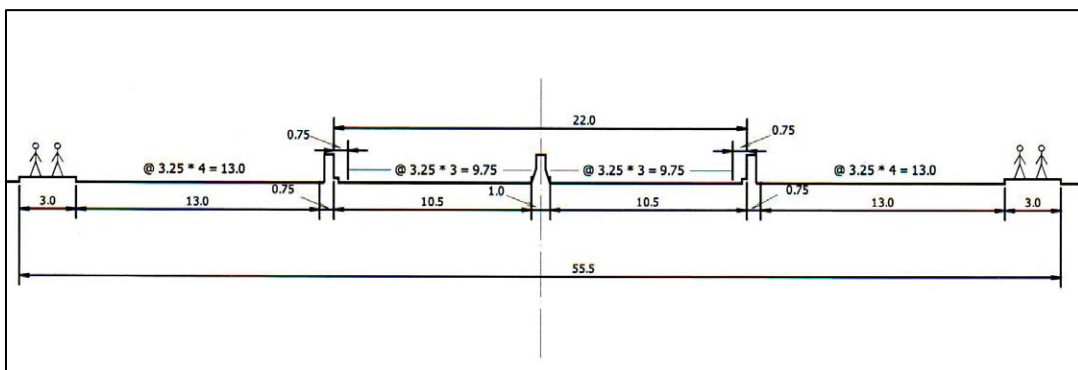

Figure A6.1-2 Typical Cross Section 2 (At - Grade)

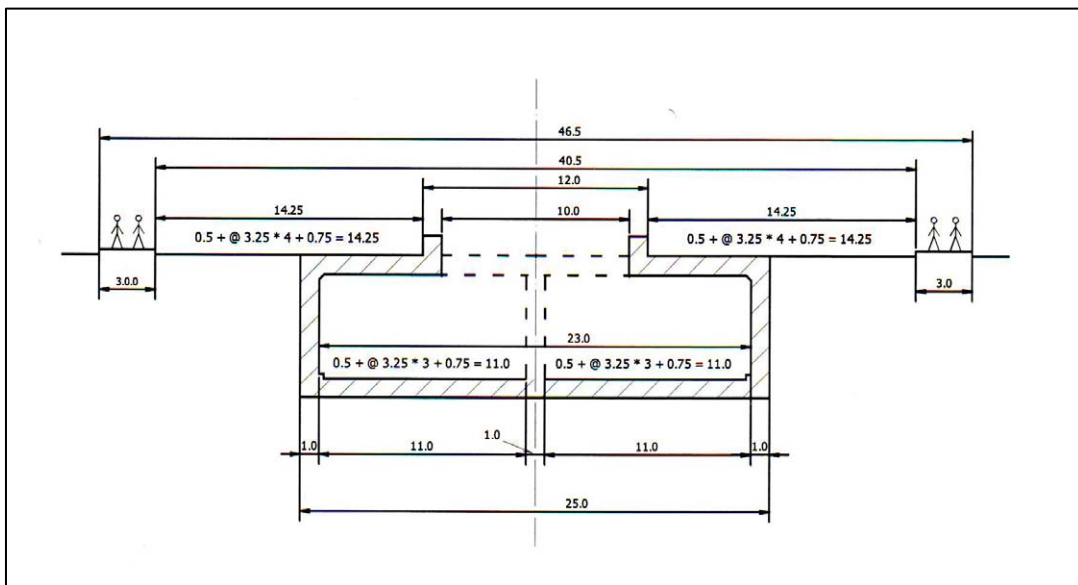

Figure A6.1-3 Typical Cross Section 3 (Half - Underground)

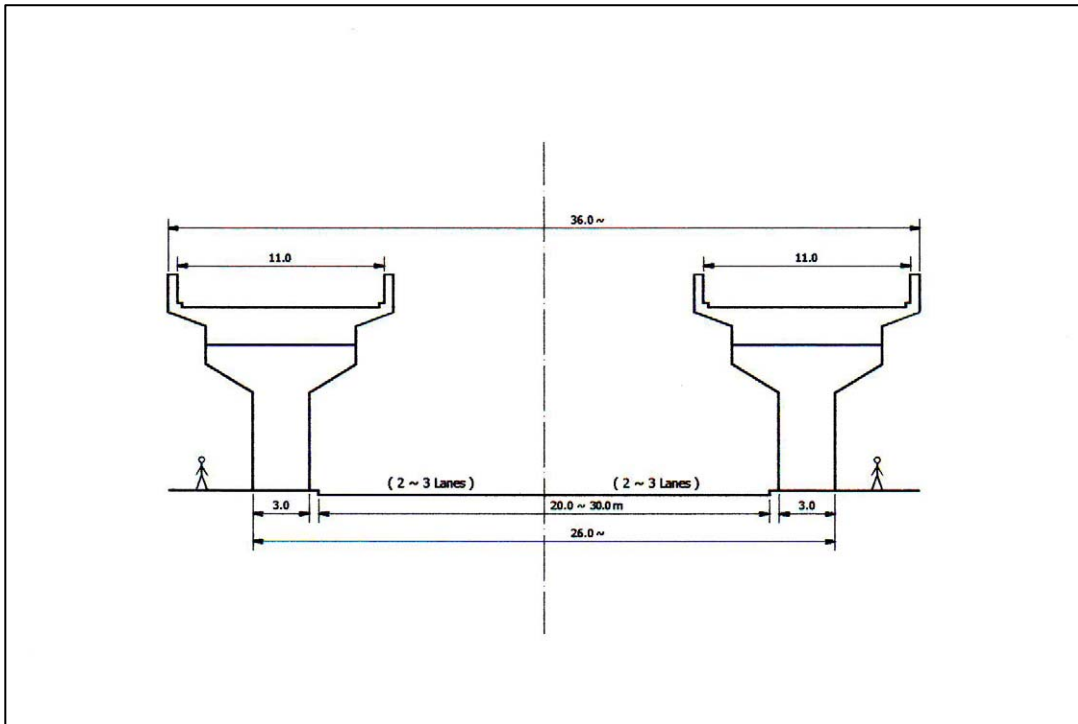

Figure A6.1-4 Typical Cross Section 4 (Separated Viaduct)

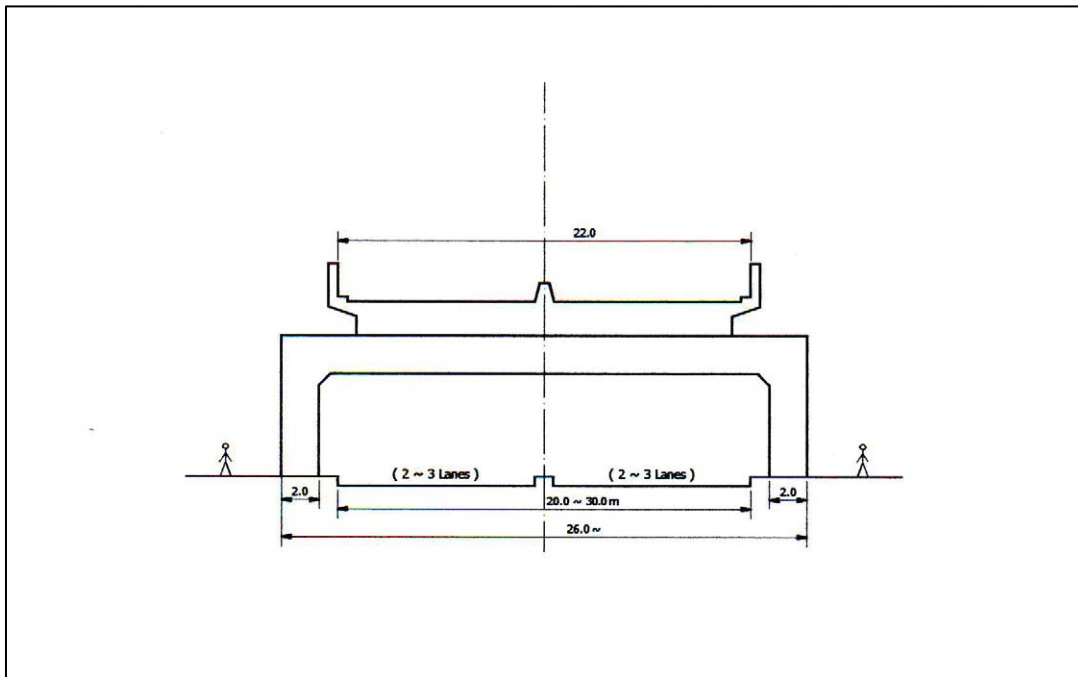

Figure A6.1-5 Typical Cross Section 5 (Gantry - Pier Viaduct)

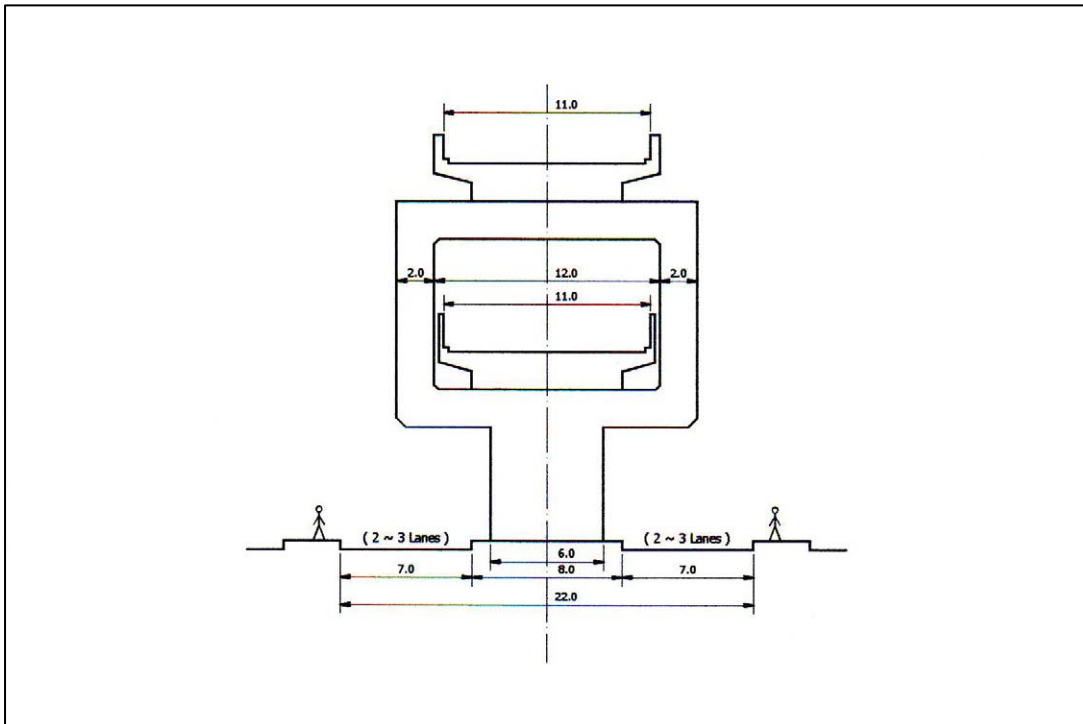

Figure A6.1-6 Typical Cross Section 6 (Double Deck, Single Pier)

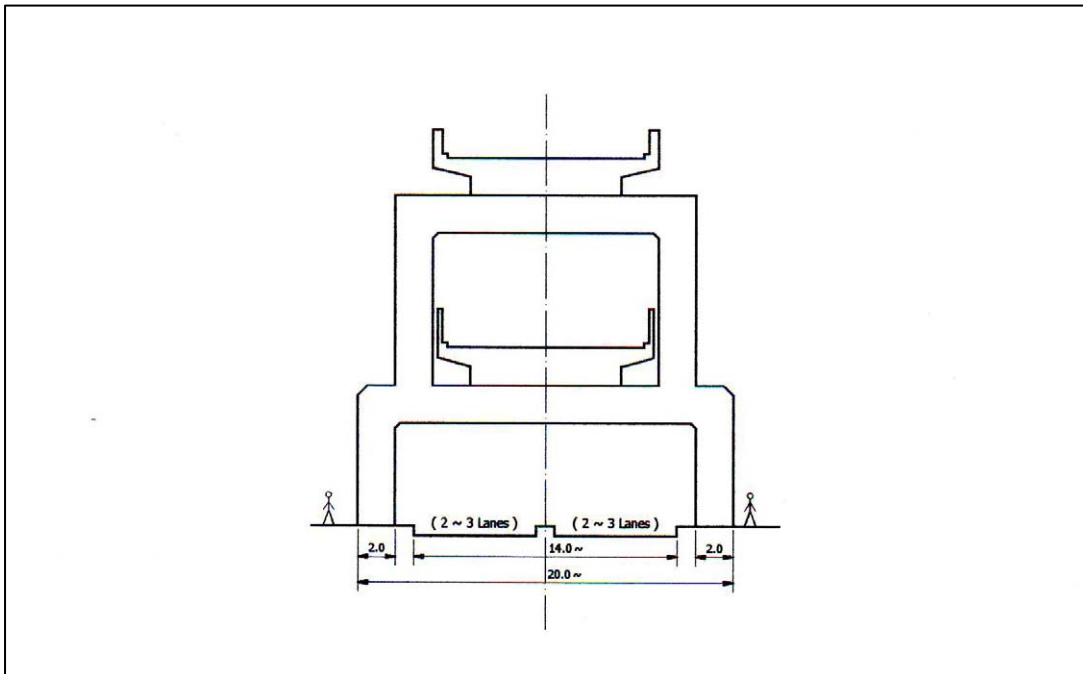

Figure 6.1-7 Typical Cross Section 7 (Double Deck, Gantry Pier)

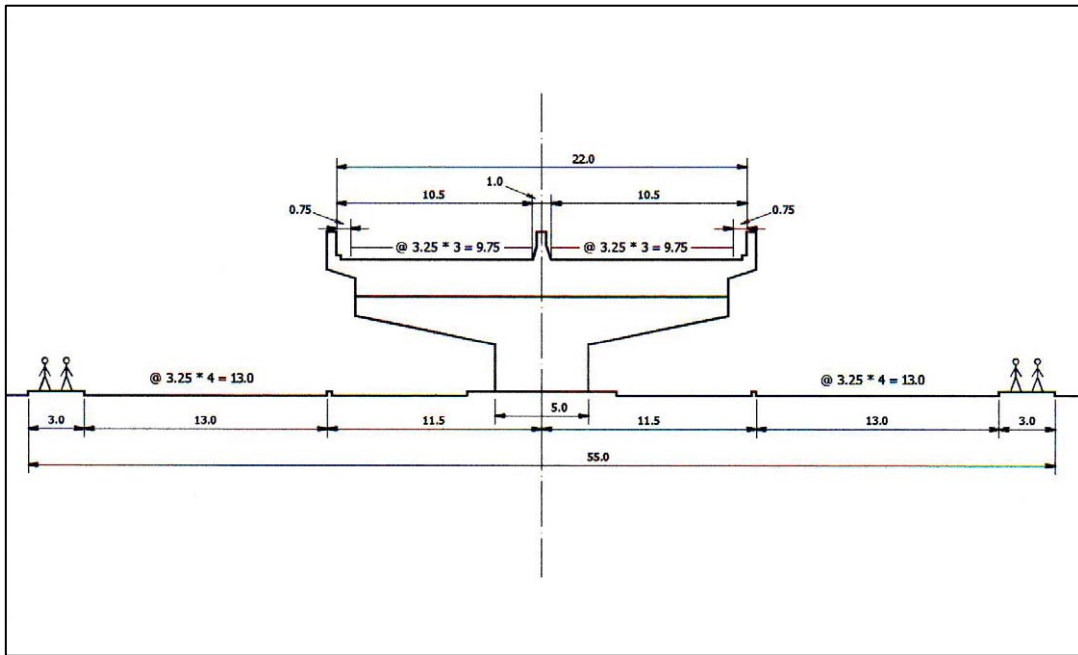

Figure A6.1-8 Typical Cross Section 8 (Transition Between Viaduct & At – Grade)

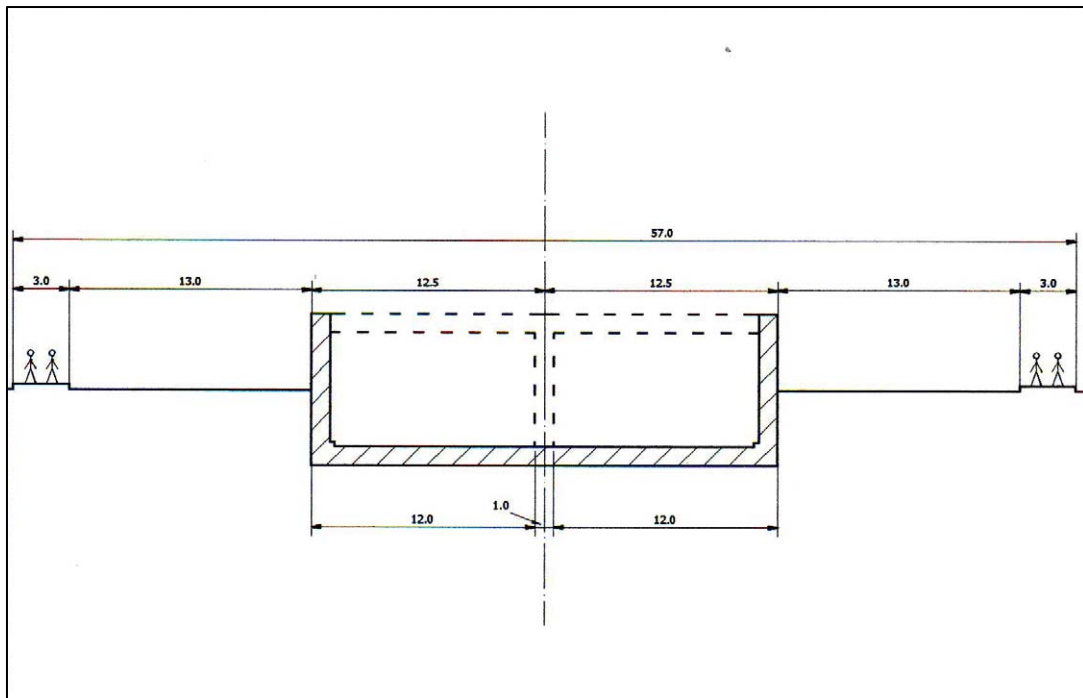

Figure A6.1-9 Typical Cross Section 9 (Transition Between At – Grade & Underground)

