

1-1-7) Group Electric Shop

Item No.

Qty

1) Electric Universal Tester

1

Drive shaft speed: 300 - 2,800 r.p.m.

Motor: 2.2KW

Tachometer: 0 - 5,000, 0 - 10,000 r.p.m.

Dimension: 1,500 x 1,400 x 800mm

Type ETB-500

2) Commutator Mica Cutter & Lathe

1

Bed size: 800 x 130mm

Suring over bed: 240mm

Max. distance between centers: 340mm

Motor: 465W

Type F-180

3) Dry Oven

1

Temperature: 50 - 300°C

Internal dimension: 450 x 400 x 400mm

Type DX-58

4) Working Table

3

Dimension: 1,780(W) x 600(D) x 750(H)mm

with two drawers

Type T-1000

Refer to 1-1-1, Item No.2

5) Auto Megger

1

Resistance: 1 - 1,000 M-Ohm/500V

Type E-17-4

Item No.

6) Circuit Tester

DC: 0 - 2,5/5/10/25/50V

AC: 0 - 10/50/250/1,000V

Type TH-20

Refer to 1-1-3, Item No.45

7) Battery Charger

DC Output: 6 - 12V

AC Input : Single phase

Power/Current/Factor: 1.4KVA/14A/97%

Type HRC-7520 (M)

8) Table

Size: 1,000(W) x 700(D) x 700(H)mm

with seat

Type 3628ZL/2218ZZ

9) Rack

Size: 1,800(H) x 900(W) x 450(D)mm

Type 6367BB

10) Vice

Jaw width: 150mm

Jaw opening: 155mm

Type UV-150

Refer to 1-1-1, Item No.3

11) Mechanic Set

Consist of: open end wrench

6 x 7, 8 x 9, 10 x 11, 11 x 13, 12 x 14,

14 x 17, 19 x 21mm each 1 pc.

Item No.

Qty

box wrench
8 x 9, 10 x 11, 11 x 13, 12 x 14, 17 x 19,
19 x 21, 22 x 24mm each 1 pc,
flare nut wrench: 10 x 11, 12 x 14mm each 1 pc,
socket wrench for 9,5mm
8, 9, 10, 11, 12, 13, 14, 17, 19, 21, 22, 23,
24mm each 1 pc.
ratchet handle, nut spinner handle, sliding T
handle, extension bars, universal joint, plug
wrench for 9,5mm, adjustable wrench 250mm,
plier 200, 150mm, nipper 150mm, hammer 450g
- driver 75, 100, 150, 200mm
+ driver 75, 100, 150mm: stubby driver -, +
integral handle driver 280mm, thickness gauge,
plug gap gauge, flat chisel, center punch,
needle file set, point file with case

Type CU-305

Refer to 1-1-1, Item No.12

12) Mechanic Set

3

Consist of: open end wrench
6 x 7, 8 x 9, 10 x 12, 11 x 13, 12 x 14, 14 x 17,
19 x 21mm each 1 pc,
box wrench
8 x 9, 10 x 12, 11 x 13, 12 x 14, 14 x 17,
17 x 19, 19 x 21, 22 x 24mm each 1 pc.
flare nut wrench: 10 x 11, 12 x 14mm each 1 pc,
socket wrench for 12,7mm
8, 9, 10, 11, 12, 13, 14, 17, 19, 21, 22, 23,
24mm each 1 pc.
ratchet handle, nut spinner handle, sliding T
handle, extension bars, universal joint, plug
wrench for 12,7mm, adjustable wrench 250mm,

Item No.

plier 200, 150mm, nipper 150mm, hammer 450g
- driver 75, 100, 150, 200mm
+ driver 75, 100, 150mm: stubby driver -, +
integral handle driver 280mm, thickness gauge,
plug gap gauge, flat chisel, center punch,
needle file set, point file with case

Type CU-405

13) Copper Hammer

Weight: 650g

Type CH-24

Refer to 1-1-2, Item No.9

14) Impact Driver

With (-) bit and (+) bit each 3 pcs.

Type #2600

Refer to 1-1-3, Item No,41

15) Snap Ring Plier Set

Range: 0 - 60mm for stem

0 - 55mm for groove

Type SPS-4

Refer to 1-1-2, Item No.11

16) Cutting Plier

Overall length: 150mm

Type No.205

17) Battery Hydrometer

Hydrometer, Thermometer, Syringe

Type HM-100

Item No.		Qty
18)	Solderless Terminal Kit Case dimension: 255 x 150 x 25mm Type ST-140	3
19)	Hexagon Wrench 1,25 - 3.0mm 5 pcs./set Type AW-50 Refer to 1-1-6, Item No.30	1
20)	Hexagon Wrench 3 - 17mm 9 pcs./set Type AW-90 Refer to 1-1-6, Item No.31	1
21)	Hexagon Wrench 5/32 - 5/8 inch 9 pcs./set Type AW-100 Refer to 1-1-6, Item No.32	1
22)	Air Drill Capacity: 6.5mm Revolution: 2,900 r.p.m. with PS coupler - nipple and hose 5m Type AD-65A	2
23)	Air Grinder Wheel dia.: 100mm Revolution: 10,500 - 11,500 r.p.m. with PS coupler - nipple and hose 5m Type M-22S Refer to 1-1-1, Item No.11	1

Item No.

24) Air Grinder

Disc-paper dia.: 100mm

Revolution: 12,000 r.p.m.

with PS coupler - nipple and hose

Type M-18S

25) Air Grinder

Capacity: 6mm

Revolution: 25,000 r.p.m.

with 8 stones, PS coupler - nipple and hose 5m

Type L-25S

26) Electric Soldering Iron

Capacity: 200W, 1 - phase

Overall length: 365mm

Iron size: 16 ϕ x 125mm

Type EI-20

27) Electric Soldering Iron

Capacity: 550W

Overall length: 470mm

Iron size: 25 ϕ x 170mm

Type EI-50

28) Solder

Combination Tin 50%, Lead 50%

0.5kg per roll

Type ROS

29) Soldering Paste Flux

Type P-1B 500g/can

Item No.

Qty

30) Electric Pencil

1

Power: 1 - phase

Type EPA

Refer to 1-1-3, Item No.40

31) Letter Punch

1

Size: 6mm

Type LET-6

32) Figure Punch

1

Size: 6mm

Type FIG-6

33) Punch Set

1

20 pcs. of punch and chisel

Type 320

Refer to 1-1-2, Item No.27

34) Air Gun

2

Weight: 800g Length: 76 x 80mm

with pg coupler and nipple

Type AGB-320

Refer to 1-1-2, Item No.12

35) Vacuum Cleaner

1

Motor: 950W, 1 - phase

Dimension: 580(H) x 360 ϕ mm

Type MC-2000

1-1-7

Item No. 1

Name Electric Universal Tester

Type ETB-500

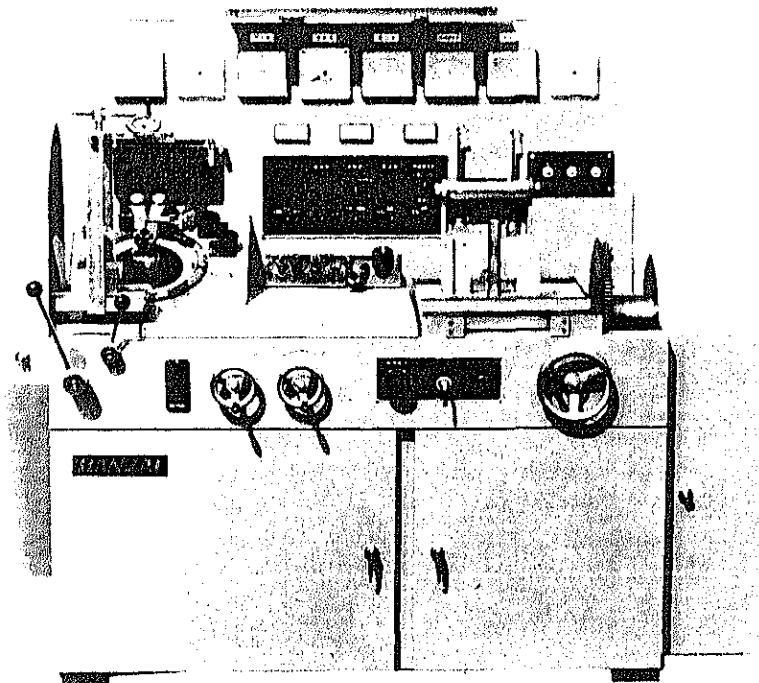

CONSTRUCTION PROJECT OF AUTOMOBILE REPAIR & MAINTENANCE WORKSHOP IN BANGLADESH	DATE
	SCALE
TITLE OF DRAWING	ORG. NO. —
JAPAN INTERNATIONAL COOPERATION AGENCY	

1-1-7

Item No. 2

Name Commutator Mica Cutter
& Lathe

Type F-180

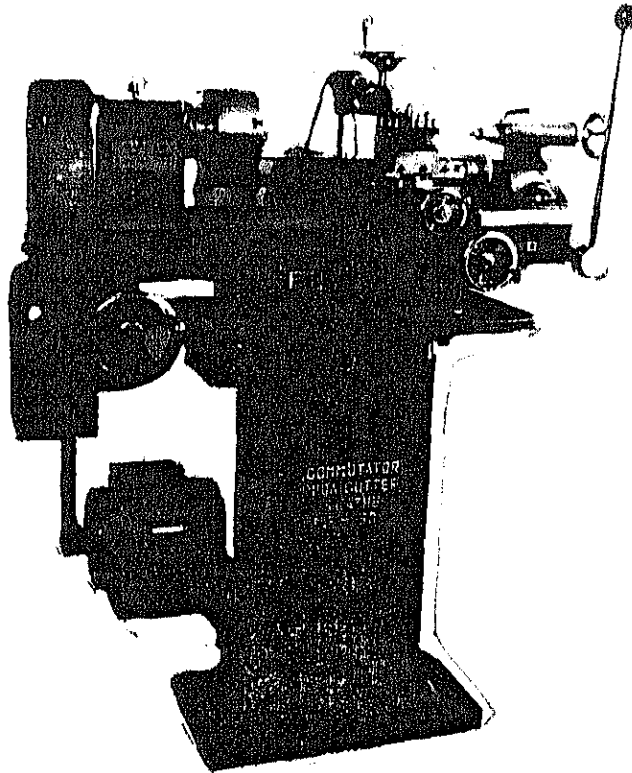

CONSTRUCTION PROJECT OF AUTOMOBILE REPAIR & MAINTENANCE WORKSHOP IN BANGLADESH	DATE
	SCALE
TITLE OF DRAWING	ORG. NO. -
JAPAN INTERNATIONAL COOPERATION AGENCY	

1-1-7

Item No. 3

Name Dry Over

Type DX-58

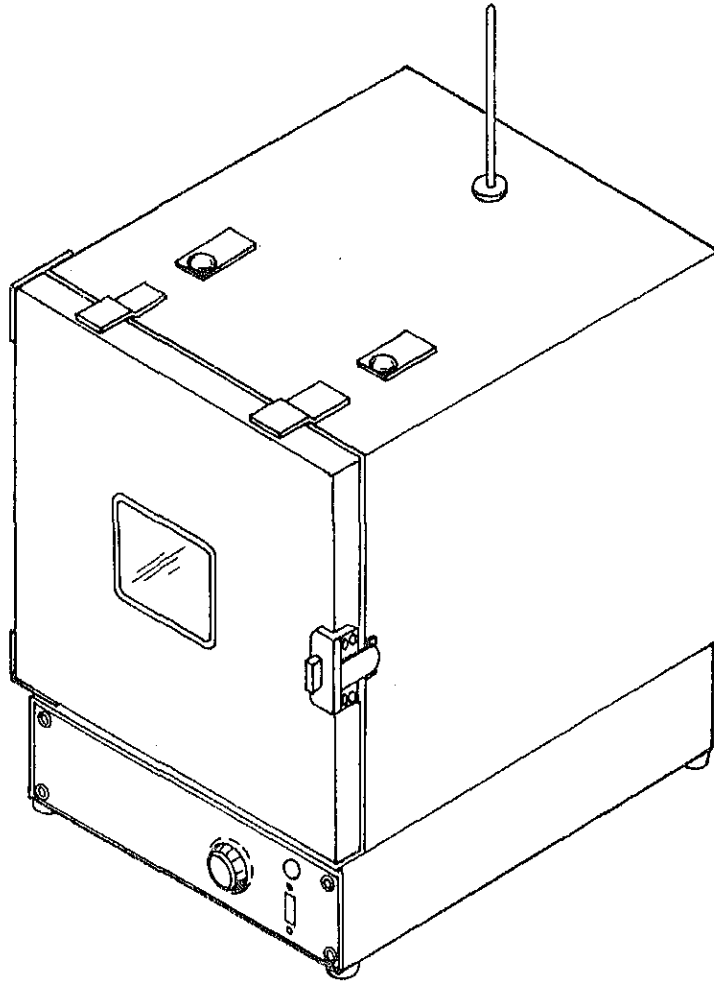

CONSTRUCTION PROJECT OF AUTOMOBILE REPAIR & MAINTENANCE WORKSHOP IN BANGLADESH	DATE
	SCALE
TITLE OF DRAWING	DRG. NO. —
JAPAN INTERNATIONAL COOPERATION AGENCY	

1-1-7
Item No. 5
Name Auto Megger
Type E-17-4

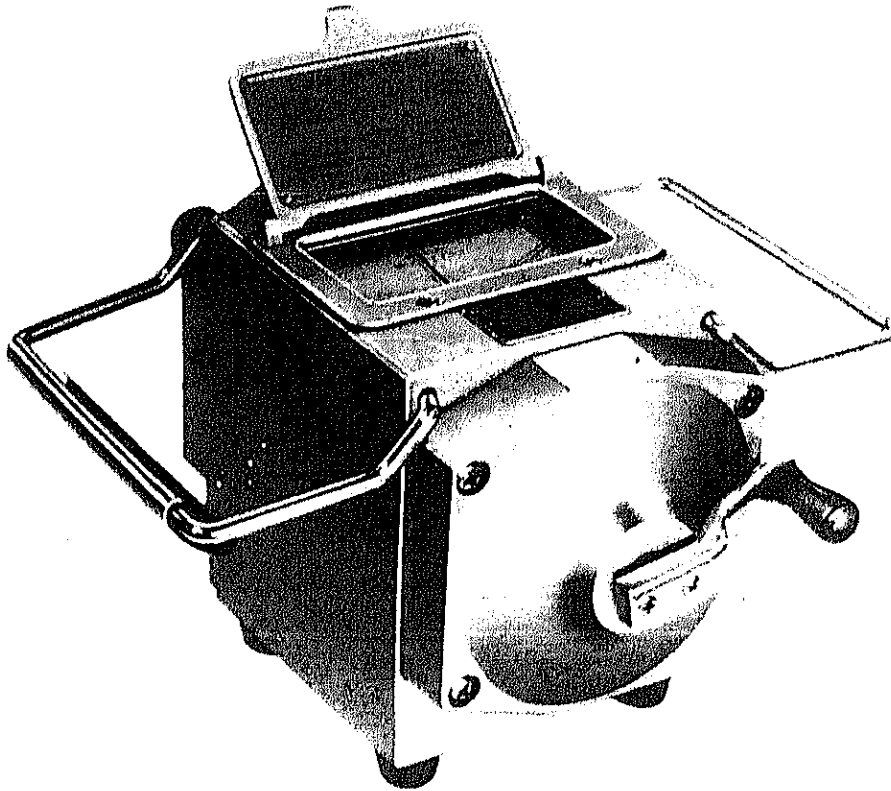

CONSTRUCTION PROJECT OF AUTOMOBILE REPAIR & MAINTENANCE WORKSHOP IN BANGLADESH	DATE
	SCALE
TITLE OF DRAWING	DRG. NO. —
JAPAN INTERNATIONAL COOPERATION AGENCY	

1-1-7

Item No. 7

Name Battery Charger

Type HRC-7520

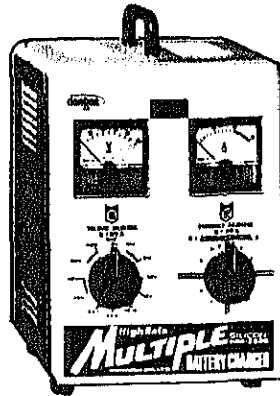

CONSTRUCTION PROJECT OF AUTOMOBILE REPAIR & MAINTENANCE WORKSHOP IN BANGLADESH	DATE
	SCALE
TITLE OF DRAWING	ORG. NO. —
JAPAN INTERNATIONAL COOPERATION AGENCY	

1-1-7

Item No. 8

Name Table

Type 3628ZL/2218ZZ

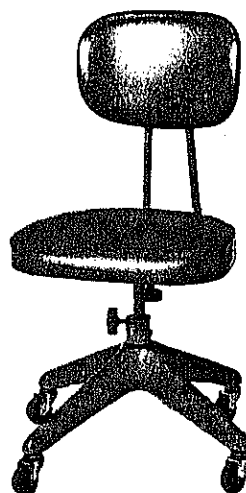
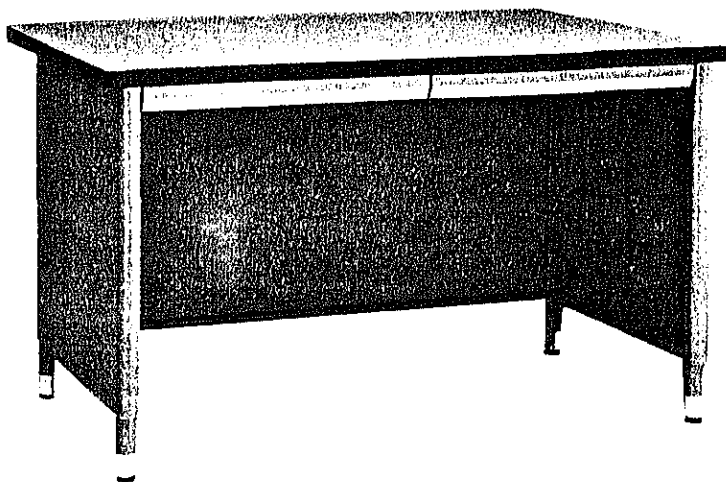

CONSTRUCTION PROJECT OF AUTOMOBILE REPAIR & MAINTENANCE WORKSHOP IN BANGLADESH	DATE
	SCALE
TITLE OF DRAWING	DRG. NO. —
JAPAN INTERNATIONAL COOPERATION AGENCY	

1-1-7

Item No. 9

Name Rack

Type 6367BB

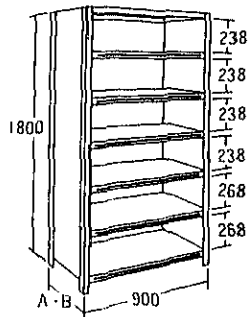

CONSTRUCTION PROJECT OF AUTOMOBILE REPAIR & MAINTENANCE WORKSHOP IN BANGLADESH	DATE
	SCALE
TITLE OF DRAWING	ORG. NO. —
JAPAN INTERNATIONAL COOPERATION AGENCY	

__1-1-7__

Item No. 12

Name Mechanic Set

Type CU-405

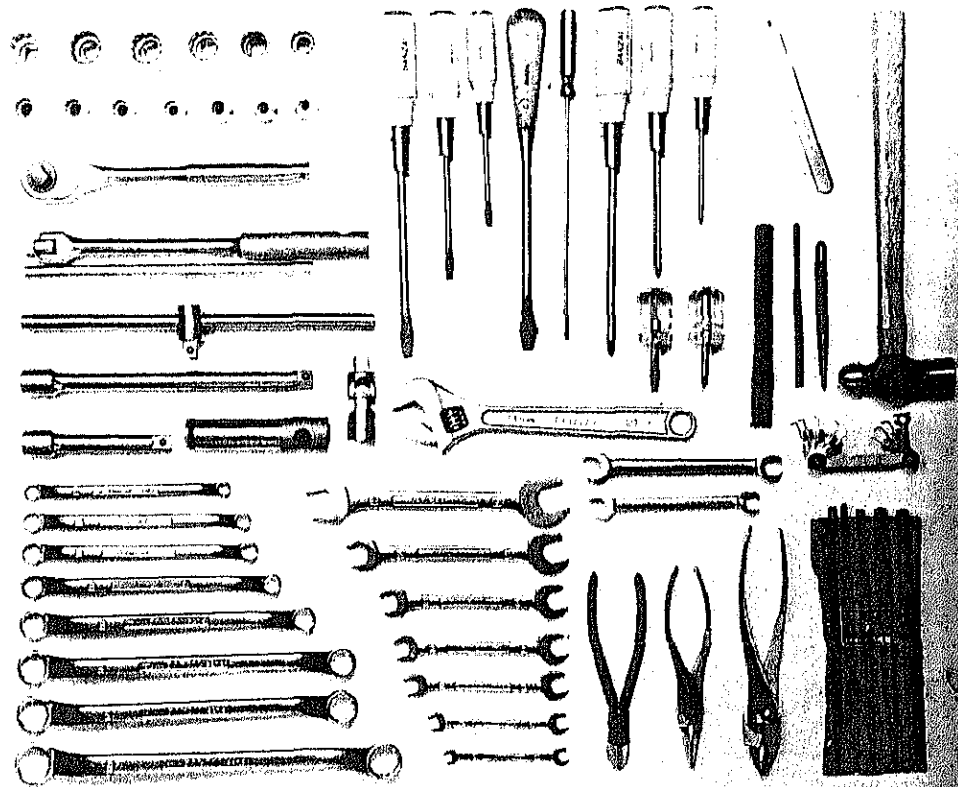

CONSTRUCTION PROJECT OF AUTOMOBILE REPAIR & MAINTENANCE WORKSHOP IN BANGLADESH	DATE
	SCALE
TITLE OF DRAWING	ORG. NO. —
JAPAN INTERNATIONAL COOPERATION AGENCY	

1-1-7

Item No. 16

Name Cutting Plier

Type No.205

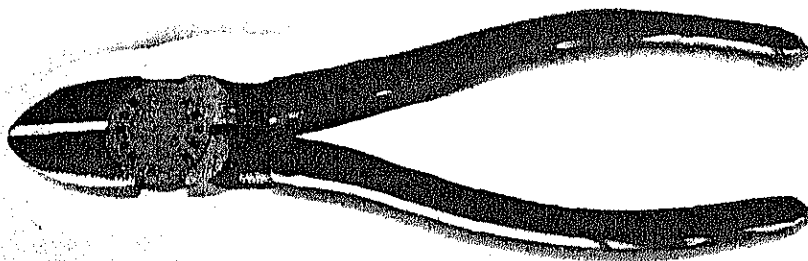

CONSTRUCTION PROJECT OF AUTOMOBILE REPAIR & MAINTENANCE WORKSHOP IN BANGLADESH	DATE
	SCALE
TITLE OF DRAWING	DRG. NO. —
JAPAN INTERNATIONAL COOPERATION AGENCY	

1-1-7

Item No. 17

Name Battery Hydrometer

Type HM-100

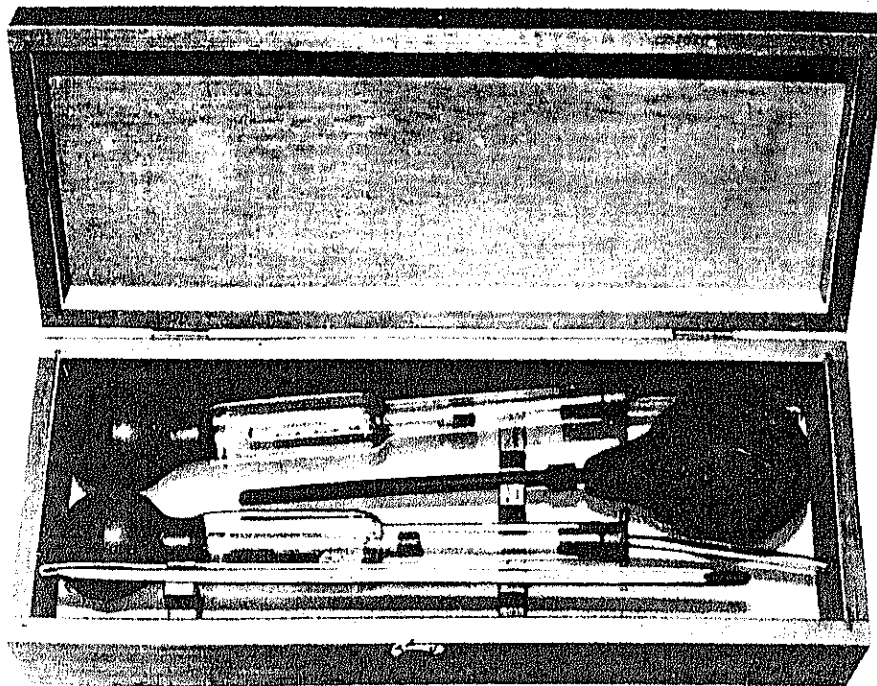

CONSTRUCTION PROJECT		DATE
OF		SCALE
AUTOMOBILE REPAIR & MAINTENANCE WORKSHOP		
IN BANGLADESH		
TITLE OF DRAWING		ORG. NO.
		—
JAPAN INTERNATIONAL COOPERATION AGENCY		

1-1-7

Item No. 18

Name Solderless Terminal Kit

Type ST-140

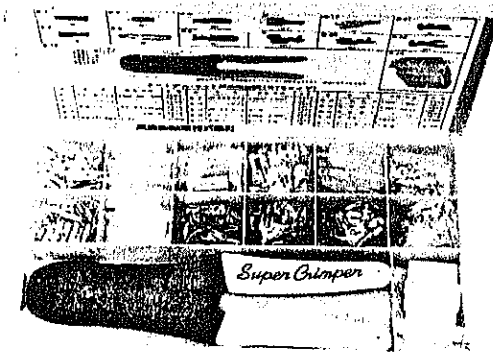

CONSTRUCTION PROJECT OF AUTOMOBILE REPAIR & MAINTENANCE WORKSHOP IN BANGLADESH		DATE
TITLE OF DRAWING		SCALE
		ORG. NO. —
JAPAN INTERNATIONAL COOPERATION AGENCY		

1-1-7
Item No. 22

Name Air Drill

Type AD-65A

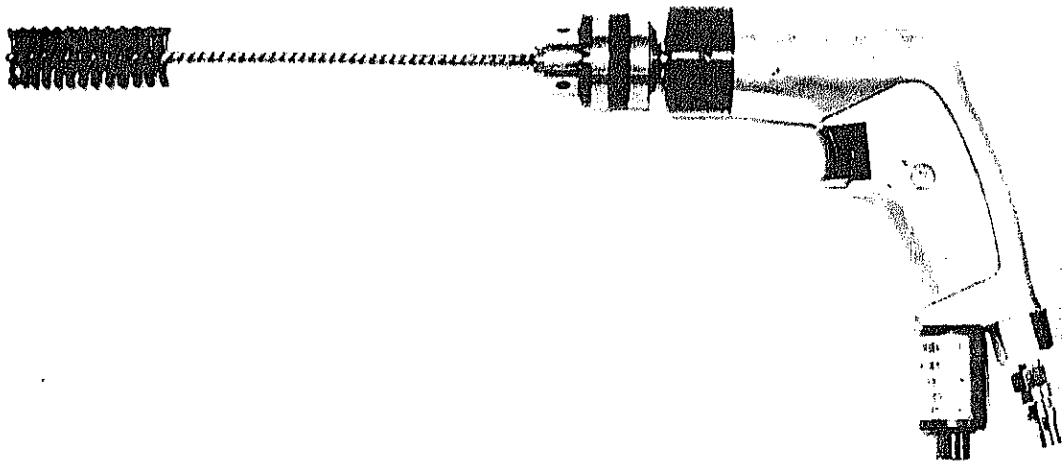

CONSTRUCTION PROJECT OF		DATE
AUTOMOBILE REPAIR & MAINTENANCE WORKSHOP IN BANGLADESH		SCALE
TITLE OF DRAWING		ORG. NO.
JAPAN INTERNATIONAL COOPERATION AGENCY		-

1-1-7

Item No.	24
Name	Air Grinder
Type	M-18S

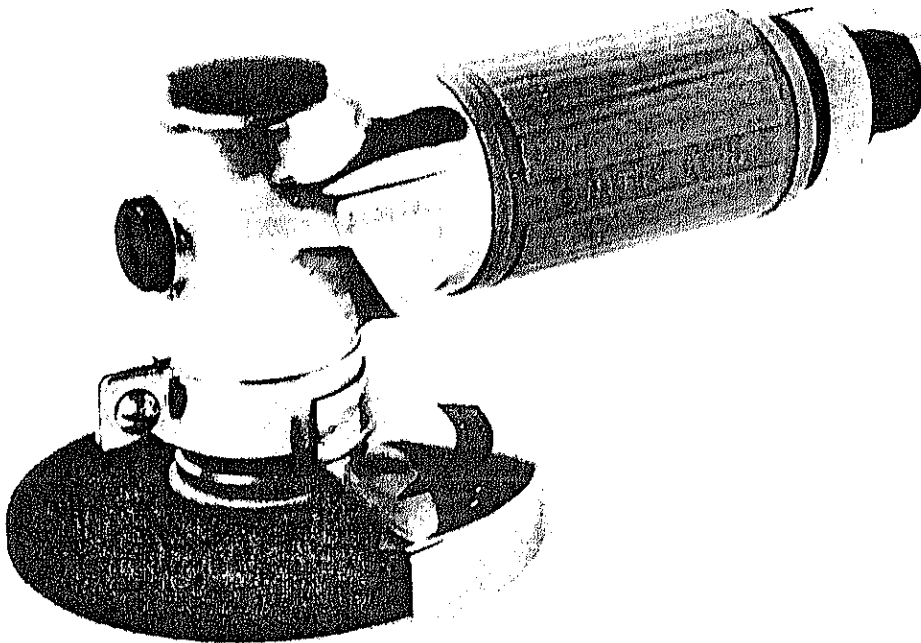

CONSTRUCTION PROJECT OF AUTOMOBILE REPAIR & MAINTENANCE WORKSHOP IN BANGLADESH	DATE
	SCALE
TITLE OF DRAWING	ORG. NO. -
JAPAN INTERNATIONAL COOPERATION AGENCY	

1-1-7

Item No. 25

Name Air Grinder

Type L-25S

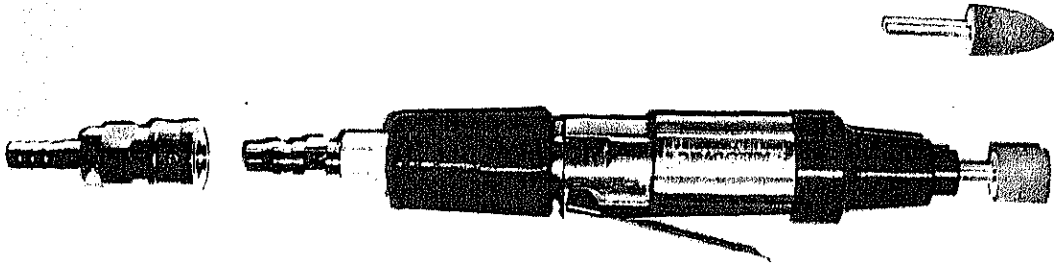

CONSTRUCTION PROJECT OF AUTOMOBILE REPAIR & MAINTENANCE WORKSHOP IN BANGLADESH		DATE
TITLE OF DRAWING		SCALE
		ORG. NO. —
JAPAN INTERNATIONAL COOPERATION AGENCY		

1-1-7

Item No. 26

Name Electric Soldering Iron

Type EI-20

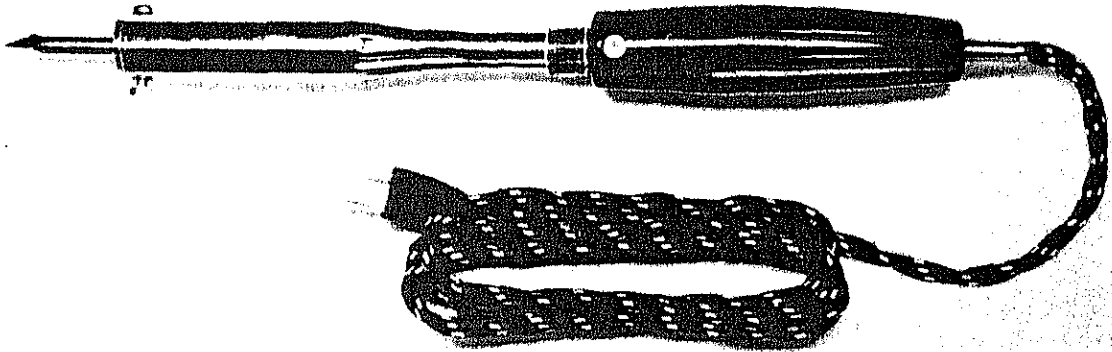

CONSTRUCTION PROJECT OF AUTOMOBILE REPAIR & MAINTENANCE WORKSHOP IN BANGLADESH	DATE
	SCALE
TITLE OF DRAWING	DRG. NO. —
JAPAN INTERNATIONAL COOPERATION AGENCY	

1-1-7

Item No. 27

Name Electric Soldering Iron

Type EI-50

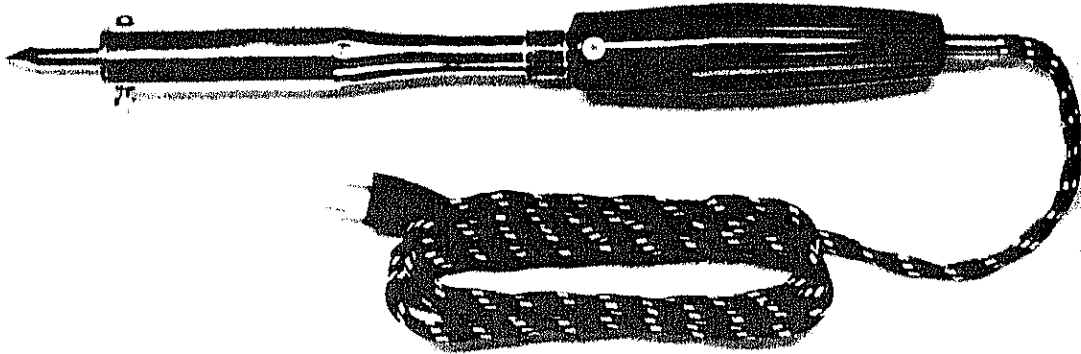

CONSTRUCTION PROJECT OF AUTOMOBILE REPAIR & MAINTENANCE WORKSHOP IN BANGLADESH	DATE
	SCALE
TITLE OF DRAWING	DRG. NO. —
JAPAN INTERNATIONAL COOPERATION AGENCY	

1-1-7

<u>Item No.</u>	<u>28</u>
<u>Name</u>	<u>Solder</u>
<u>Type</u>	<u>ROS</u>

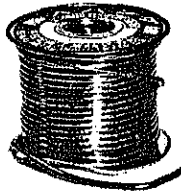

CONSTRUCTION PROJECT OF AUTOMOBILE REPAIR & MAINTENANCE WORKSHOP IN BANGLADESH	DATE
	SCALE
TITLE OF DRAWING	ORG. NO. —
JAPAN INTERNATIONAL COOPERATION AGENCY	

1-1-7

Item No. 29

Name Soldering Paste Flux

Type P-1B



CONSTRUCTION PROJECT OF AUTOMOBILE REPAIR & MAINTENANCE WORKSHOP IN BANGLADESH		DATE
TITLE OF DRAWING		SCALE
		ORG. NO. -
JAPAN INTERNATIONAL COOPERATION AGENCY		

1-1-7

Item No. 31

Name Letter Punch

Type LET-6

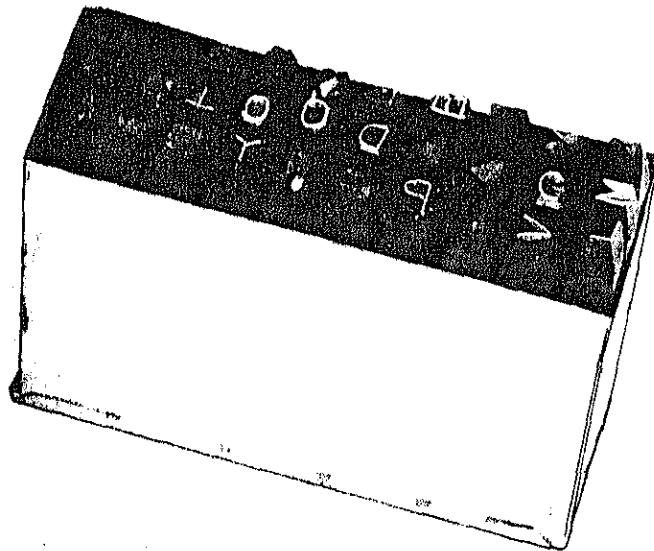

CONSTRUCTION PROJECT OF AUTOMOBILE REPAIR & MAINTENANCE WORKSHOP IN BANGLADESH	DATE
	SCALE
TITLE OF DRAWING	ORG. NO. -
JAPAN INTERNATIONAL COOPERATION AGENCY	

---1-1-7---

Item No. 32

Name Figure Punch

Type FIG-6

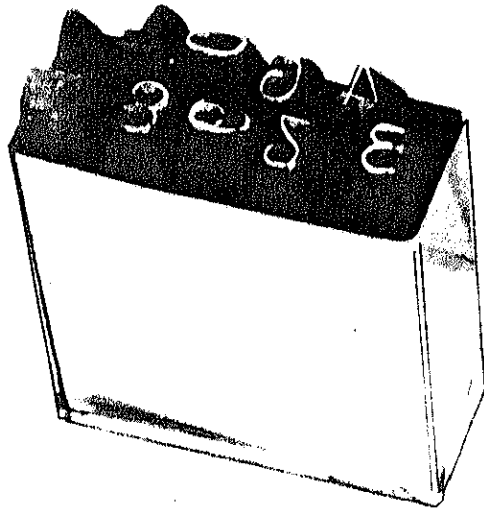

CONSTRUCTION PROJECT OF AUTOMOBILE REPAIR & MAINTENANCE WORKSHOP IN BANGLADESH	DATE
	SCALE
TITLE OF DRAWING	ORG. NO. —
JAPAN INTERNATIONAL COOPERATION AGENCY	

1-1-7

Item No. 35

Name Vacuum Cleaner

Type MC-2000

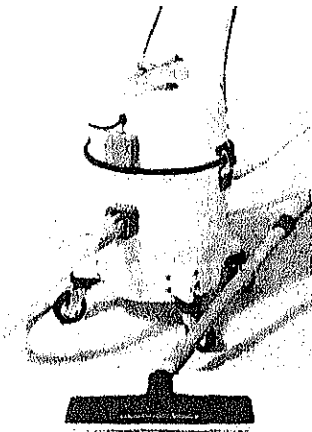

CONSTRUCTION PROJECT OF AUTOMOBILE REPAIR & MAINTENANCE WORKSHOP IN BANGLADESH	DATE
	SCALE
TITLE OF DRAWING	ORG. NO.
JAPAN INTERNATIONAL COOPERATION AGENCY	

1-1-8) Group Pump Shop

Item No.

Qty

1) Fuel Injection Pump Test Bench

3

Motor: 7.5KW & 0.75KW

Speed control: 2 step; 0 - 1,000 r.p.m.

0 - 3,000 r.p.m.

Measuring cylinder: 45cc x 12 pcs.

Stroke setting device: between 100 - 1,200 stroke
every 100 strokes

with AB kit and feed pump tester

Type 5760-050

Drawing No. G-002

2) Nozzle Tester

3

Pressure gage: 0 - 500kg/cm²

Fuel reservoir: 600cc

with flow - control valve and adaptor

Type DT-60V

3) Injection Pump Stand

3

Overall height: 360mm

Type DT-65B

4) Injection Pump Special Tool Set

3

Consist of 35 pcs. tools

Type DT-105A

5) Working Bench

6

Size: 1,780(L) x 600(W) x 750(H)mm

with two drawers

Type T-1000

Refer to 1-1-1, Item No.2

Item No.

6) Vice

Jaw opening: 155mm

Jaw width: 150mm

Type UV-150

Refer to 1-1-1, Item No.3

7) Parts Washing Stand

Motor: 200W

Tank capacity: 55 lit - oil

45 lit - water

Discharge : 14 lit/min.

with air outlet

Type WS-25

Refer to 1-1-2, Item No.5

8) Table

Size: 1,200(W) x 800(D) x 700(H)mm

with seat

Type 3616DE/2218ZZ

9) Open End Wrench Set

Size: 8 x 9, 10 x 12, 12 x 14, 14 x 17, 19 x 21, 23 x 26mm

Type BT-5

10) Open Eng Wrench Set

Size: 1/4 x 5/16, 3/8 x 7/16, 1/2 x 9/16, 5/8 x 11/16,

3/4 x 13/16, 7/8 x 15/16

Type BT-6A

Qty

3

2

1

1

1

1-1-8

Item No. 1-1/2

Name Fuel Injection Pump Test

Bench

Type 5760-050

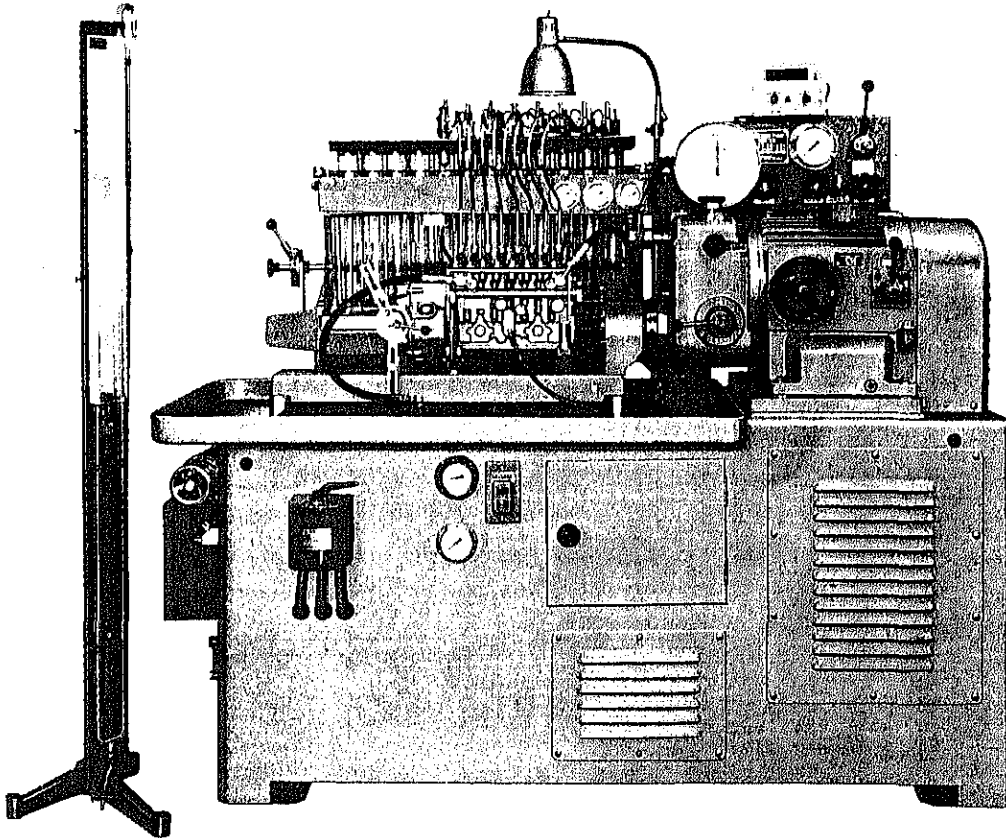

CONSTRUCTION PROJECT OF AUTOMOBILE REPAIR & MAINTENANCE WORKSHOP IN BANGLADESH		DATE
TITLE OF DRAWING		SCALE
		ORG. NO.
JAPAN INTERNATIONAL COOPERATION AGENCY		—

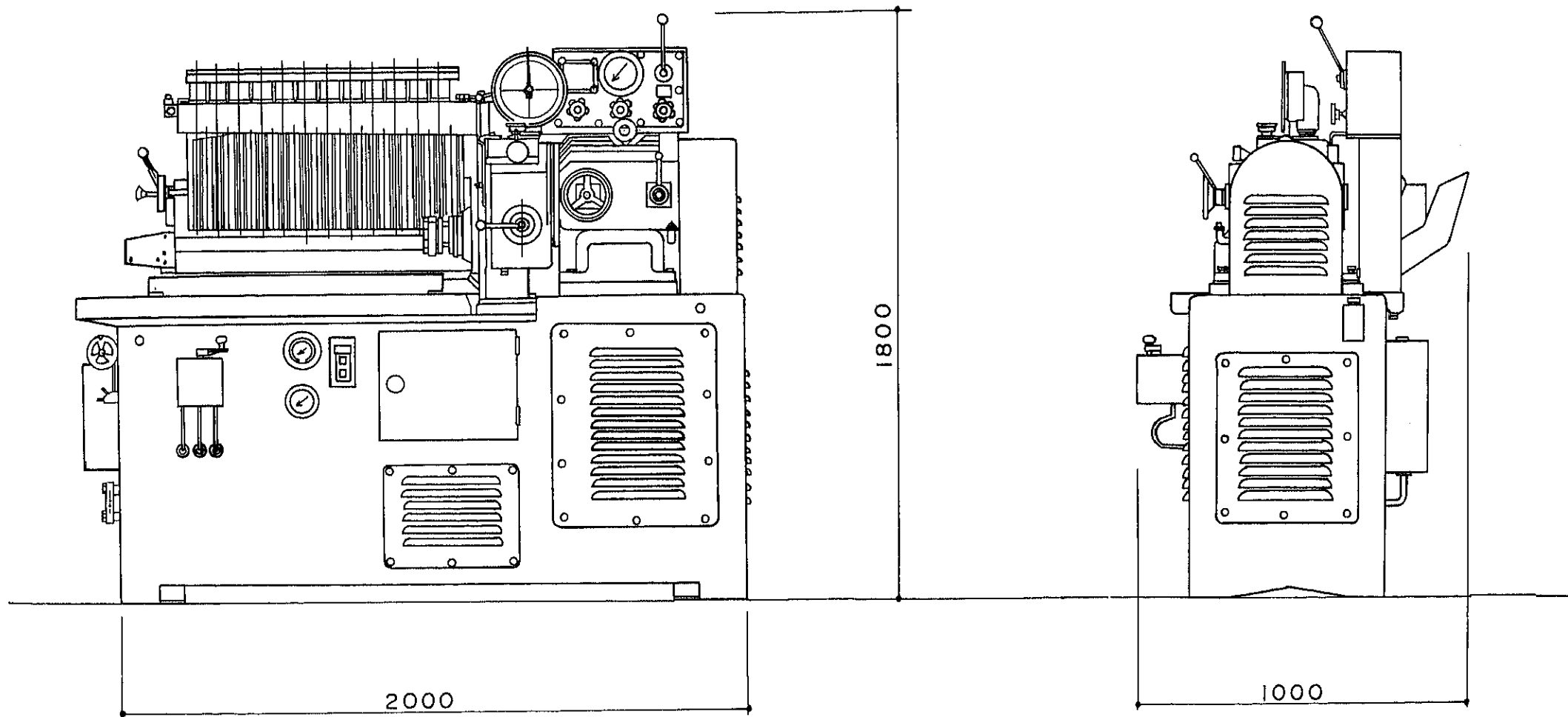

1-1-8
 Item NO. 1-2/2
 Name Fuel Injection Pump Test Bench
 Type 5760-050

CONSTRUCTION PROJECT OF AUTOMOBILE REPAIR & MAINTENANCE WORKSHOP IN BANGLADESH		DATE
TITLE OF DRAWING INJECTION PUMP TESTER		SCALE
		DRG. NO G - 002
JAPAN INTERNATIONAL COOPERATION AGENCY		

1-1-3
Item No. 2
Name Nozzle Tester
Type DT-60V

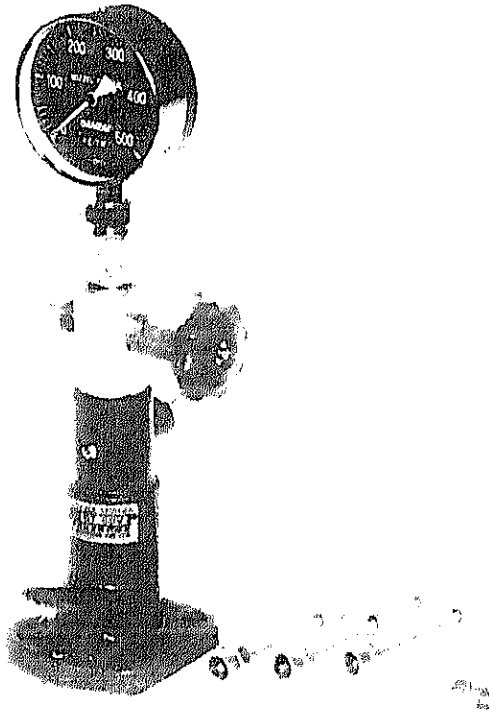

CONSTRUCTION PROJECT OF AUTOMOBILE REPAIR & MAINTENANCE WORKSHOP IN BANGLADESH	DATE
	SCALE
TITLE OF DRAWING	ORG. NO.
	—
JAPAN INTERNATIONAL COOPERATION AGENCY	

1-1-8

Item No. 3

Name Injection Pump Stand

Type DT-65B

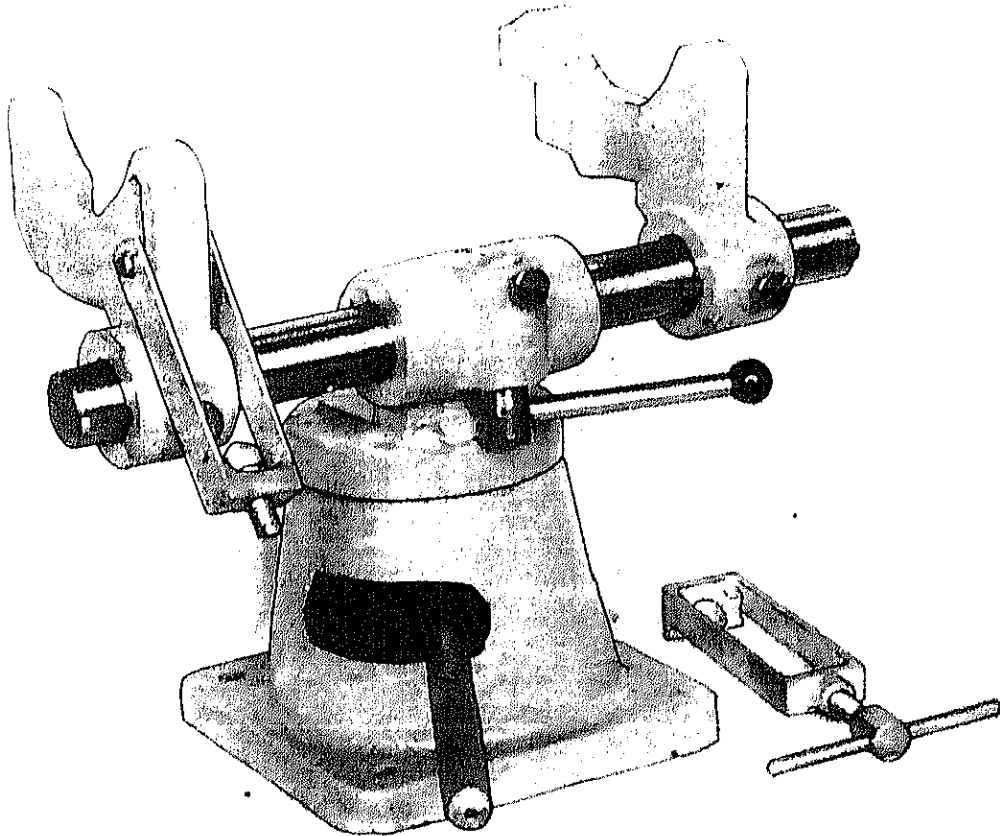

CONSTRUCTION PROJECT OF AUTOMOBILE REPAIR & MAINTENANCE WORKSHOP IN BANGLADESH	DATE
	SCALE
TITLE OF DRAWING	DRG. NO. —
JAPAN INTERNATIONAL COOPERATION AGENCY	

1-1-8

Item No. 4

Name Injection Pump Special

Tool Set

Type DT-105A

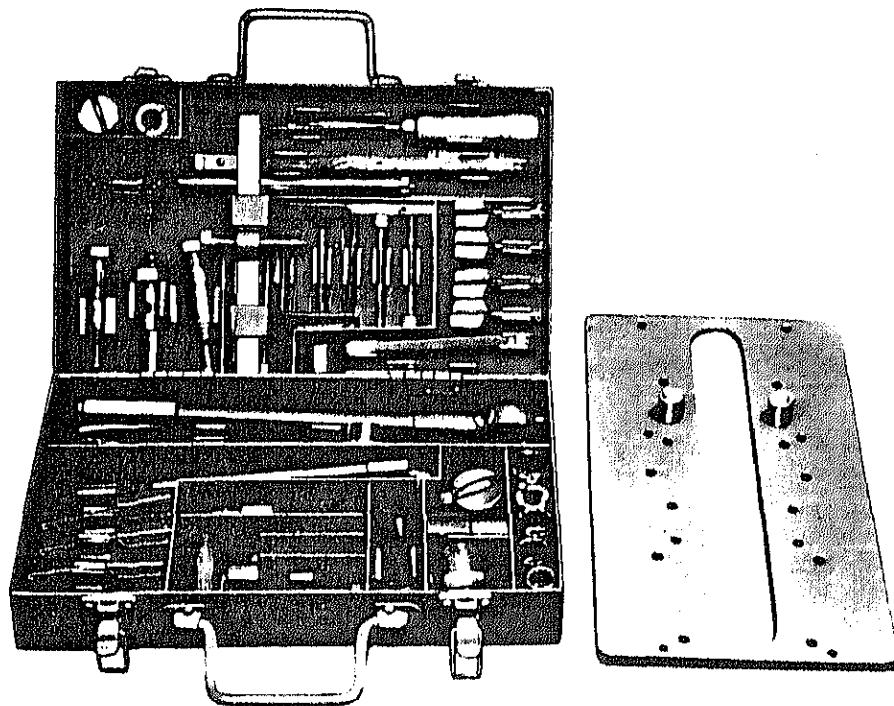

CONSTRUCTION PROJECT OF AUTOMOBILE REPAIR & MAINTENANCE WORKSHOP IN BANGLADESH	DATE
	SCALE
TITLE OF DRAWING	DRG. NO. —
JAPAN INTERNATIONAL COOPERATION AGENCY	

1-1-8

Item No. 8

Name Table

Type 3616DE/2218ZZ

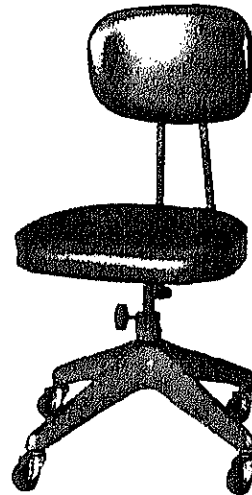
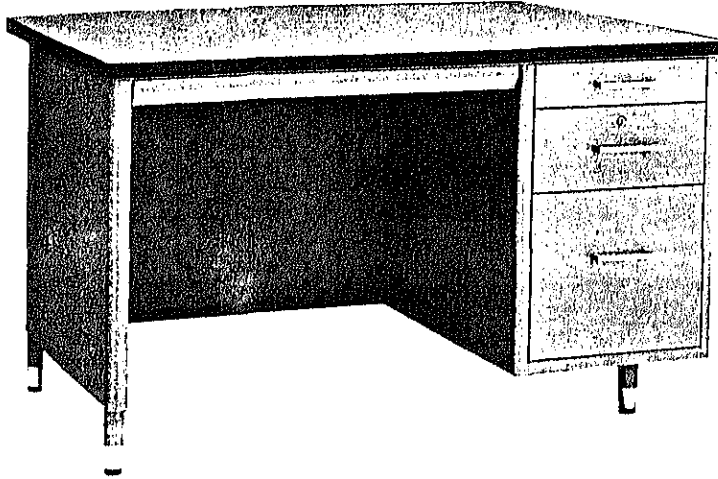

CONSTRUCTION PROJECT OF		DATE
AUTOMOBILE REPAIR & MAINTENANCE WORKSHOP IN BANGLADESH		SCALE
TITLE OF DRAWING		DRG. NO.
JAPAN INTERNATIONAL COOPERATION AGENCY		

1-1-8

Item No. 9

Name Open End Wrench Set

Type BT-5



CONSTRUCTION PROJECT OF		DATE
AUTOMOBILE REPAIR & MAINTENANCE WORKSHOP IN BANGLADESH		SCALE
TITLE OF DRAWING		ORG. NO. -
JAPAN INTERNATIONAL COOPERATION AGENCY		

1-1-8

Item No. 10

Name Open End Wrench Set

Type BT-6A



CONSTRUCTION PROJECT OF AUTOMOBILE REPAIR & MAINTENANCE WORKSHOP IN BANGLADESH	DATE
	SCALE
TITLE OF DRAWING	ORG. NO. —
JAPAN INTERNATIONAL COOPERATION AGENCY	

1-1-9) Group General Machine Shop

(Item No.

1) Crankshaft Grinder

Dual head drive system

Max. length of crankshaft: 2,100mm

Max. swing of crankshaft: 700mm

Max. crankshaft weight: 1,000kg

Wheel dimension: 915 x 32 x 279.4mm

Grinding wheel motor: 7.5KW

Table quick travers motor: 0.75KW

with accessories

Type MG-2100

Drawing No.G-003

2) Cylinder Boring Machine

Capacity bore: 80 - 165mm

stroke: 500mm

Moror: 0.25 & 0.6KW

with stand

Type NWA-No.2

3) Cylinder Honing Machine

Honing capacity: 54 - 110mm ϕ

Spinable stroke: 0 - 330mm

Main motor: 1.5KW

Type MS-902

Drawing No.G-004

4) Valve Refacer

Chuck capacity: 6 - 14.5mm

Chuck revolution: 350 r.p.m.

Grinding angle graduated: 0, 15, 30, 45, 60, 75, 90

with stand

Type MB-145

Item No.

5) Valve Seat Cutter Set

Cutter: 22 - 60mm ϕ

Pilot: 5.5 - 12mm ϕ

Type R-2500

6) Valve Seat Grinder, Eccentric Type

Capacity valve seat: 38 - 160mm

valve stem: 10 - 25 mm

Driving motor: 250W

Grinding wheel: 10 pcs. with stand

Type EC-160

7) Hexagon Wrench Set

Size: 1.27 - 3.0mm 5 pcs./set

Type AW-50

Refer to 1-1-6, Item No.30

8) Hexagon Wrench Set

Size: 3 - 17mm 9 pcs./set

Type AW-90

Refer to 1-1-6, Item No.31

9) Hexagon Wrench Set

Size: 5/32 - 5/8" 9 pcs./set

Type AW-100

Refer to 1-1-6, Item No.32

10) Socket Wrench Set

12.7mm Aq.dr. Socket: 3/8 - 1 inch 13 pcs.

Type No.30

(Item No.

11) Socket Wrench Set

12.7mm Aq. dr. Socket: 8 - 32mm 13 pcs.
Type No.33S

12) Screw Tap & Dies Set

Metric; 28 medium tap; 26 dies
Type M-320

13) Screw Tap & Dies Set

NF(SAE) 8 medium taps; 8 dies
Type T-412

14) Adjustable Reamer Set

Adjustable range: 12 - 38mm
Contents: 12 pcs.
Type PL-44

15) Combination Milling Machine

Ram type

Table size: 1,200 x 270mm

Longindinal travers: 800mm

Cross traverse: 310mm

Vertical traverse: 420mm

Spindle speed: 16 steps

45, 100, 125, 160, 200, 260, 330, 390, 420, 800, 1,050,
1,300, 1,700, 2,150, 2,700, 3,500 r.p.m.

Spindle automatic feed: 0.05, 0.08, 0.15mm per rev.

Spindle motor: 1.5, 1.1KW 3 phase

Type FX-800

Drawing No.G-005

Item No.

(6) Lathe

Specifications

Swing over bed: : 510mm
Swing over cross slide: 300mm
Distance between center: 2,000mm
Swing in gap : 710mm
Spindle nose : A1-6"
Hole thru spindle : 52mm
Spindle center : MT No.4
Spindle speed number & range: 12, 25 - 1,500 r.p.m.
English threads number & range: 32, 4 - 56t p.i.
Metric threads number & range : 21, 0.5 - 7mm
Longitudinal feeds number & range: 32, 0.035 - 0.5mm/rev.
Cross feeds : 1/2 of longitudinal feeds
Tailstock spindle dia. : 65mm
- do - center : MT No.4
- do - travel : 150mm
Main motor : 5.5KW
Type TAL 510 x 2000
Drawing No.G-006

(7) Radial Drilling Machine

Working area of base : 1,270 x 760mm
Spindle speed : 30 - 1,500 r.p.m. 6 steps
Spindle feed : 0.06 - 1.0mm 6 steps
Drilling capacity : 50mm - cast iron
45mm - steel
Spindle head longitudinal travel: 805mm
Vertical arm travel : 610mm
Spindle travel : 300mm
Motor : 2.2KW, 0.75KW
0.4KW, 0.075KW
3 phase

Item No.

Qty

Table size : 450 x 550 x 360mm
Type HOR-1100

(18) Turret Lathe

1

Swing over bed : 400mm
Swing over carriage : 220mm
Spindle speed : 4 steps
Collect capacity : 50 ϕ mm
Saddle feed : 0.06 - 0.64 6 steps
Motor : 3.7KW
Bed length : 1,350mm
Distance between spindle & turret : 460mm
Cutting length of turret : 210mm
Turret feed : 0.08 - 0.75mm/rev. 6 steps
Type HTL-50E
Drawing No.G-007

(19) Surface Grinder

1

Table surface : 95 x 220mm
Grinding range : 450 x 250 x 350mm
Motor : 1.5KW x 0.75KW 3 phase
Grinding wheel speed : 2,600 r.p.m.
Grinding wheel size : 205 x 19 x 50.8mm
Longitudinal travel : 470mm
Longitudinal tank feed : 2 - 20mm/min.
Cross travel : 270mm
Vertical wheel head travel : 350mm
Type SGW-4
Drawing No.G-008

Item No.

20) Cutting Grinder

Cutting capacity : 115mm
Grinding wheel dia. : 405mm
Motor : 2.2KW
Type HCW-16M

21) Tool Cabinet Set

Consist of: No.26 Thickness gauge
BAG-32C Brake adjustable gauge
No.22M Spark plug gap gauge
315 Screw pitch gauge
SR-1B Stainless holding rule
BSC-20 Vernier caliper
No.30M Socket wrench set without case
long socket
14, 17, 19, 21, 23, 26, 29mm
BT-42 Offset box wrench set
BT-41 - do -
BT-62 - do -
BT-52 - do -
UB-2326 U bolt nut wrench
UBI-3034 - do -
T-20 Terminal gear puller
T-24 Gear puller
T-26 - do -
80H High tension test driver
250 Stubby driver
GF Tire gauge
V-12 Hacksaw frame
engineers file: flat 200/300mm
round 200mm with handle
PW-14 Pipe wrench

Item No.

BH-24	Ball plain hammer
TH-2	Test hammer
PH-2	Plastic hammer
	ratcheting spanner; 10, 12, 14, 17, 19, 21mm
E-10	Extension bar
TH-11	T handle
UJ-4	Universal joint
L-120M	Socket wrench set without case offset box wrench set (BT-9/BT-6A/BT-5/BT-1)
T-106M	Tappet wrench set
T-32HMF	Wheel nut wrench
T-32E	Wheel nut wrench
T-126M	Cross rim wrench
	plastic screwdriver; 50, 75, 100, 125, 150mm
	plastic cross driver; #1, 2, 3, 4
H-26	Combination plier
H-28	- do -
L-26	Thin straight nose plier
M-26	Long nose plier
J-26	Thin bent nose plier
MG-210	Water pump wrench plier
CT-7	Cutting plier
	adjustable wrench (BS-6/8/10)

Cabinet dimension: 1,020 x 440 x 210mm

Type D-3000

Refer to 1-1-3, Item No.46

Item No.

22) Brake Drum Lathe

Capacity drum dia. : 250 - 650mm ϕ

Drum width up to: 250mm

Motor : 0.75KW

Type BDL-250N

23) Bench Grinder

Wheel size: 205 x 19 x 15.88mm

Motor : 400W 3 phase

with stand

Type SGK-T/PFK

24) Surface Plate

Size: 1,000 x 750 x 180mm

Weight: 280kg

Type SPA-28

25) Working Bench

Size: 1,780(W) x 600(D) x 750(H)mm

with two drawers

Type T-1000

Refer to 1-1-1, Item No.2

26) Engineers File Set

Length: 300mm

Consist of flat, half-round, round, square, triangles

Type F-300S

27) Outside Micrometer Set

Range: 0 - 150mm

Type 1525MB

Item No.

28) Magnetic Flaw Detector

Electric cable: 2 core 5m long
Type MP-1

29) Pin Hole Honing Machine

Capacity bore : 13 - 52mm ϕ
stroke: 40 - 120mm
Motor : 0.2KW with stand
Type PH-No.1D

30) Shaping Machine

Stroke : 700mm
Table size : 520 x 400 x 350mm
Stroke rate : 6.5 - 113 8 steps
Vice : 350 x 400mm
Motor : 3.7KW 3 phase
Type NS-700
Drawing No.G-009

31) Vice

Jaw width : 150mm
Jaw opening : 155mm
Type UV-150
Refer to 1-1-1, Item No.3

32) Writing Table

Dimension : 100(W) x 700(D) x 700(H)mm
with seat
Type 3616DL/2218ZZ
Refer to 1-1-1, Item No.8

Item No.

33) Hydraulic Press

Capacity : 35 ton
Ram stroke : 140mm
Distance between frames : 675mm
Distance between tables : 185mm
Vertical travel of table : 720mm
with two correcting block
Type HP-50E

34) Snap Ring Plier

Range : 10 - 60mm for stem
10 - 55mm for groove
Type SPS-4

Refer to 1-1-2, Item No.11

35) Bush Inserter & Remover

Consist of attachment : 18 - 40mm 13 pcs.
push rod : 3 pcs.
Type T-130

Refer to 1-1-1, Item No.9

36) V Block

Size: 100 x 55 x 38mm
Type B-100B

37) Torque Wrench

Graduation : 0 - 2,800kgf./cm (50kgf.cm/unit)
Wrench size : 19mm
Type 2800F

Refer to 1-1-4, Item No.7

Item No.

38) Cylinder Gauge Set

Range : 50 - 150mm

Type BC-58

39) Piston Feeler Gauge

Thickness : 0.05 - 0.38mm

Type No.208

40) Valve Lapper

Air pressure : 6 - 8kg/cm²

Type T-510C

41) Valve Lifter

Range : 50 - 225mm

Type VL-500

Refer to 1-1-5, Item No.17

42) Parts Washing Stand

Motor : 200W 1 phase

Tank capacity : 55 lit - oil

45 lit - water

Type WS-25

Refer to 1-1-2, Item No.5

43) Screw - Extractor

Capacity : 6.5 - 19mm

Type No.1816

44) Stud Remover

Capacity : 11mm

Type SB-34A

Item No.

45) Stud Remover

Capacity : 19mm

Type SB-34B

46) Stud Remover

Capacity : 24mm

Type SB-34D

47) Air Drill

Capacity : 6.5 ϕ mm

Revolution : 2,900 r.p.m.

Air pressure required : 6kg/cm²

Type AD-65A

Refer to 1-1-7, Item No.22

48) Carbon Brush

Brush dia. : 30mm

Type 771

49) Carbon Brush

Brush dia. : 50mm

Type 772

50) Carbon Brush

Brush dia. : 40mm

Type 773

51) Carbon Cleaning Set

Consist of wire brush, wire wheel brush

Carbon removing brush and valve guide

Brush 7, 8, 9, 10mm each 1 pc.

Type 750

Qty

2

2

3

3

3

3

3

Item No.	Qty
52) Wire Brush 3 row with scraper Type 765 Refer to 1-1-5, Item No.18	10
53) Wire Brush 5 row packed head waved Type 766 Refer to 1-1-5, Item No.19	10
54) Scraper Overall length : 190mm Type SB-19 Refer to 1-1-5, Item No.20	10
55) Electric Pencil Dimension : 180 x 120 x 270mm Type EPA Refer to 1-1-3, Item No.40	1
56) Figure Punch Size : 5mm Type FIG-5	1
57) Letter Punch Size : 5mm Type LET-5	1
58) Oil Stone, Alandum Dimension : 200 x 50 x 25mm Type OSA-200	5

Item No.

- 59) Oil Stone, White
Dimension : 200 x 50 x 25mm
Type OSW-200
- 60) Copper Hammer
Nominal weight : 1,300g
Type CH-48
- 61) Hand Tachometer
Revolution short pointer: 10,000 r.p.m.
long pointer : 1,000 r.p.m.
Type HL
- 62) Hand Spring Balance
Capacity : 0.5kg
Type ST-0.5
- 63) Hand Spring Balance
Capacity : 2kg
Type ST-2
- 64) Hand Spring Balance
Capacity : 10kg
Type ST-10
- 65) Hand Spring Balance
Capacity : 20kg
Type ST-20
- 66) Scale Spring Balance
Capacity : 2kg
Type SB-2

Qty

5

5

3

2

2

2

2

2