

1-1-4) Group Front & Rear Axle Shop

Item No.

Qty

1) Chassis Spring Changer

3

Spring capacity: 3,000kg

Spring saddle height: min. 540mm

max. 650mm

Type SJ-1

2) Differential Jack

5

Capacity: 500kg

Saddle height: 140 - 600mm

Lift: 460mm

Type DJ-50

Refer to 1-1-3, Item No,21

3) Working Bench

3

Size: 1,780(W) x 600(D) x 750(H)mm

with two drawers

UV-150; Vice are equipped

Type T-1000

Refer to 1-1-1, Item No,2

4) Vice

3

Jaw width: 150mm

Jaw opening: 150mm

Type UV-150

Refer to 1-1-1, Item No,3

5) Tool Stand

1

Size: 620(W) x 460(D) x 800(H)mm

Interchangeable tray: 4 - steps

Type TS-34

Refer to 1-1-1, Item No,10

Item No.	Qty
<p>6) Hydraulic Press</p> <p>Capacity: 100 ton</p> <p>Ram stroke: 220mm</p> <p>Distance between frames: 1,150mm</p> <p>Distance between tables: 670mm</p> <p>Vertical travel of tables: 500mm</p> <p>Type EHP-200</p>	1
<p>7) Torque Wrench</p> <p>Range: 500 - 2,800kgf.cm²</p> <p>Size: 19mm</p> <p>Range: 50kgf.cm²</p> <p>Type 2800F</p>	3
<p>8) Surface Plate</p> <p>Size: 1,200 x 900mm</p> <p>with table</p> <p>Type SPB-46</p>	1
<p>9) Universal Puller Set</p> <p>Consist of 150HD puller set, T-75 wheel puller, T-26, T-28 gear puller, T-20 terminal puller, G-61 slide hammer puller, 101S gear puller each 1 pc, for bus</p> <p>Type UP-5000</p> <p>Refer to 1-1-2, Item No.2</p>	1
<p>10) Parts Washing Stand</p> <p>Tank capacity: 55 lit - oil</p> <p>45 lit - water</p> <p>Discharge: 14 lit/min.</p> <p>Motor: 200W, 1 - phase</p> <p>Type WS-25</p> <p>Refer to 1-1-2, Item No.5</p>	3

Item No.

Qty

11) King Pin Press Set

1

Consist of shaft 1 pc., attachment 7 pcs.
corss bar 1 pc., side shaft 2 pcs., holder 2 pcs.,
bearing 1 pc., bearing washer 2 pcs., punch 2 pcs.
Type KD-500

12) Bushing Inserter & Remover

1

Gun metal & steel bushing
Adapters: 18 - 43mm
Rubber adapters: 25 - 43mm
Case dimension: 430 x 290 x 58mm
Type SDE-1000

13) Hand Spring Balance

1

Capacity: 2kg, 5kg
For torque check of bearing
Type HSB-20
Refer to 1-1-2, Item No.3

14) Writing Table

2

Dimension: 1,000(W) x 700(D)x700(H)mm
with seat
Type 3616DL/2218ZZ
Refer to 1-1-1, Item No.8

15) Double Face Hammer

3

Nominal weight: 5.4kg
Type DSH-12

16) Housing Dies

1

For Isuzu
Type HP

Item No.	Qty
(7) Housing Dies For Mitsubishi Type HP	1
(8) Air Grinder Wheel size: 180mm Revolution: 7,000 r.p.m. Air pressure required: 6kg/cm ² Type M-70S Refer to 1-1-3, Item No,10	2
(9) Magnetic Base Overall height: 208mm Support Angle Adjustable Type YM-1	3
(10) Dial Gauge Range: 0 - 5mm Type 1044	3
(11) Dial Gauge Range: 0 - 0.3mm Type No.2	3
(12) Mechanic Set Consist of: open end wrench 6 x 7, 8 x 9, 10 x 12, 11 x 13, 12 x 14, 14 x 17, 19 x 21mm each 1 pc. box wrench 8 x 9, 10 x 12, 11 x 13, 12 x 14, 14 x 17, 17 x 19, 19 x 21, 22 x 24mm each 1 pc. flare nut wrench: 10 x 11, 12 x 14mm each 1 pc.	13

Item No.

Qty

socket wrench for 9,5mm
8, 9, 10, 11, 12, 13, 14, 17, 19, 21, 22, 23,
24mm each 1 pc.
ratchet handle, nut spinner handle, sliding T
handle, extension bars, universal joint, plug
wrench for 9.5mm, adjustable wrench 250mm,
plier 200, 150mm, nipper 150mm, hammer 450g
- driver 75, 100, 150, 200mm
+ driver 75, 100, 150mm; stubby driver -, +
integral handle driver 280mm, thickness gauge
plug gap gauge, flat chisel, center punch, needle
file set, point file with case

Type CU-305

Refer to 1-1-1, Item No,12

23) Punch Set

Consist of 20 pcs., punch & chisel

Type 320

Refer to 1-1-2, Item No.27

24) Air Gun Set

Weight: 800g

Length: 76 x 80mm

with PS coupler, nipple and hose 10m

Type AGB-320

Refer to 1-1-2, Item No,12

1

3

1-1-4

Item No. 1

Name Chassis Spring Changer

Type SJ-1

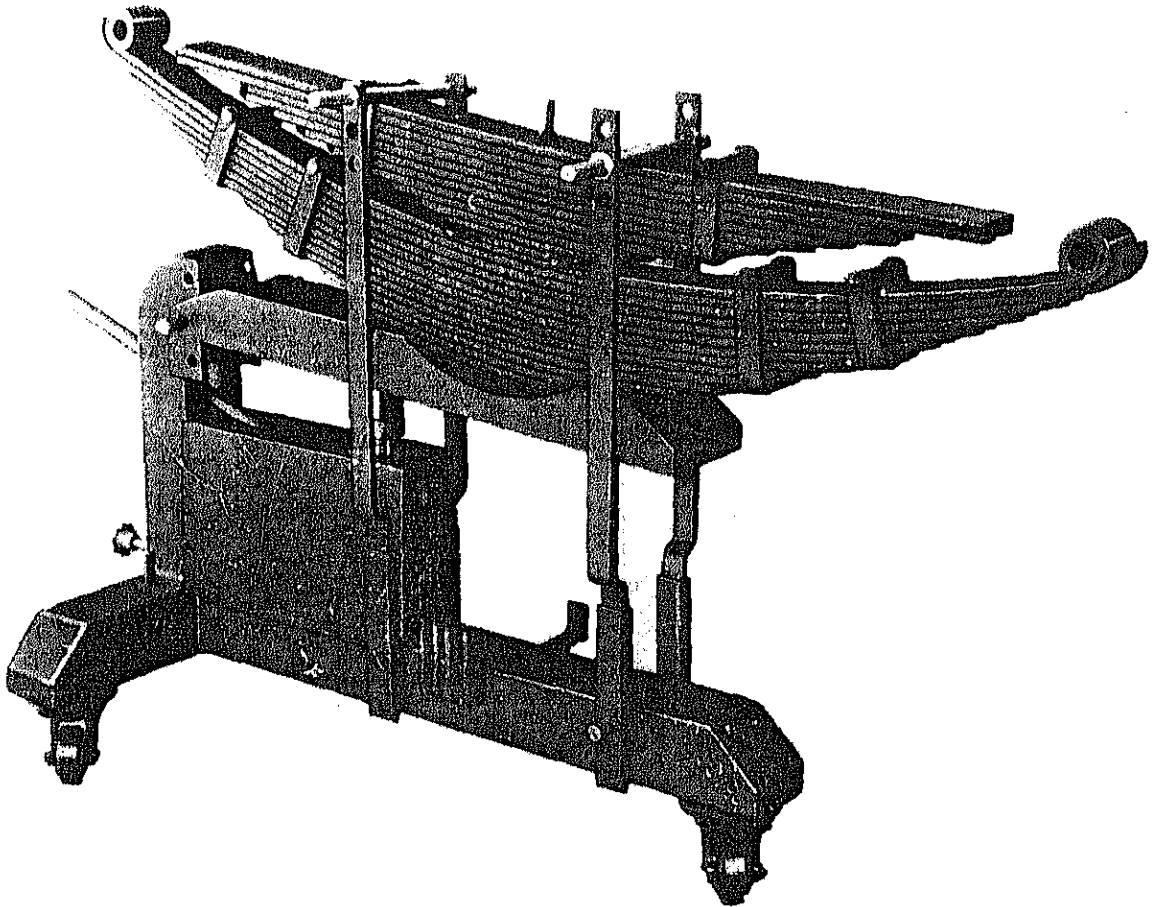

CONSTRUCTION PROJECT OF AUTOMOBILE REPAIR & MAINTENANCE WORKSHOP IN BANGLADESH	DATE
	SCALE
TITLE OF DRAWING	ORG. NO.
JAPAN INTERNATIONAL COOPERATION AGENCY	

1-1-4

Item No. 6

Name Hydraulic Press

Type EHP-200

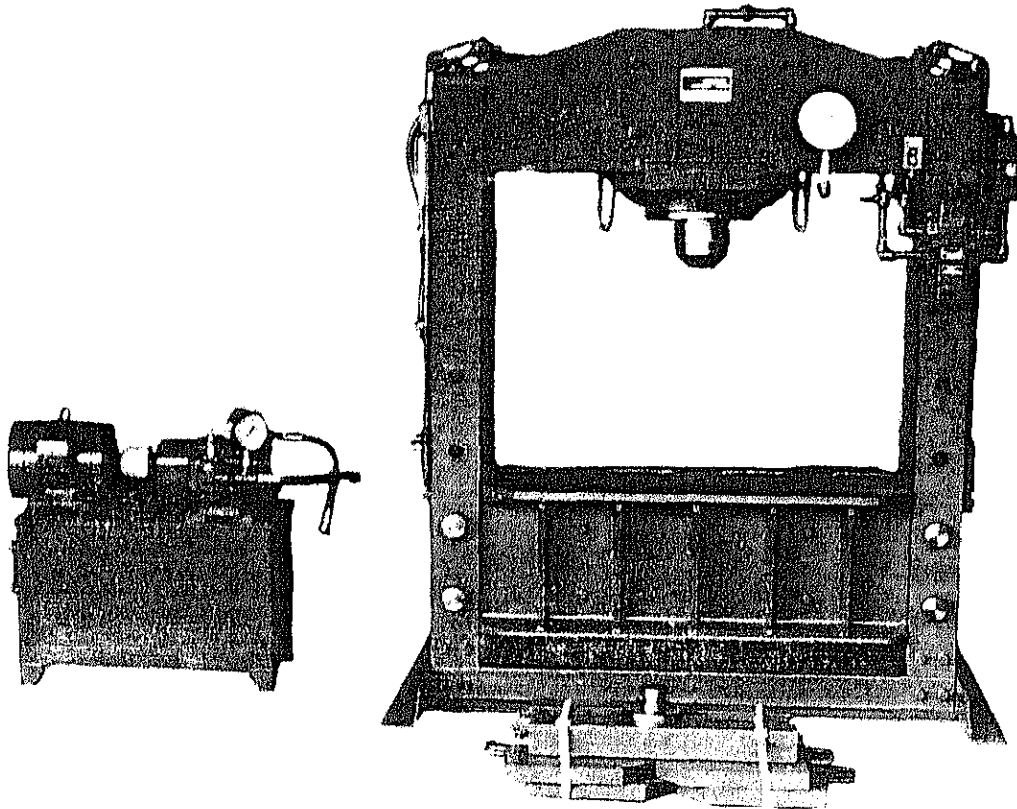

CONSTRUCTION PROJECT OF AUTOMOBILE REPAIR & MAINTENANCE WORKSHOP IN BANGLADESH	DATE
TITLE OF DRAWING	SCALE
	ORG. NO.
JAPAN INTERNATIONAL COOPERATION AGENCY	

1-1-4
Item No. 7
Name Torque Wrench
Type 2800F

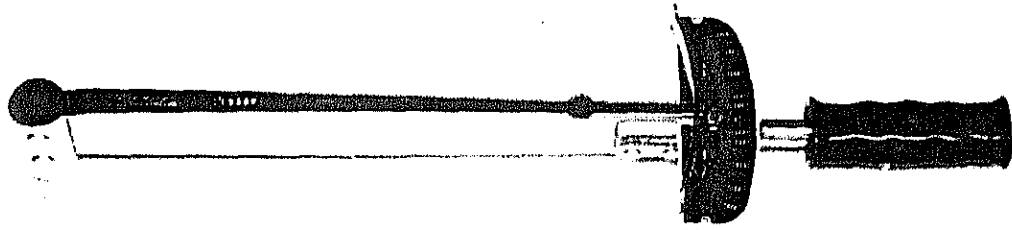

CONSTRUCTION PROJECT OF		DATE
AUTOMOBILE REPAIR & MAINTENANCE WORKSHOP IN BANGLADESH		SCALE
TITLE OF DRAWING		ORG. NO.
		—
JAPAN INTERNATIONAL COOPERATION AGENCY		

1-1-4

Item No.	8
Name	Surface Plate
Type	SPB-46



CONSTRUCTION PROJECT OF AUTOMOBILE REPAIR & MAINTENANCE WORKSHOP IN BANGLADESH	DATE
	SCALE
TITLE OF DRAWING	ORG. NO. —
JAPAN INTERNATIONAL COOPERATION AGENCY	

1-1-4

Item No. 11

Name King Pin Press Set

Type KP-500

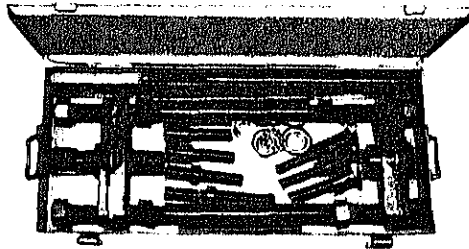

CONSTRUCTION PROJECT OF AUTOMOBILE REPAIR & MAINTENANCE WORKSHOP IN BANGLADESH	DATE
	SCALE
TITLE OF DRAWING	ORG. NO. —
JAPAN INTERNATIONAL COOPERATION AGENCY	

1-1-4

<u>Item No.</u>	<u>12</u>
<u>Name</u>	<u>Bushing Inserter & Remover</u>
<u>Type</u>	<u>SDE-1000</u>

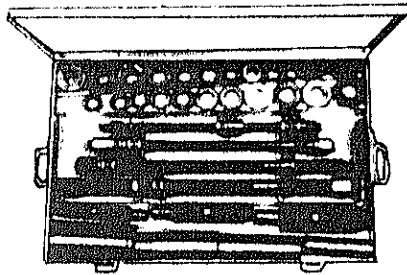

CONSTRUCTION PROJECT OF AUTOMOBILE REPAIR & MAINTENANCE WORKSHOP IN BANGLADESH	DATE
	SCALE
TITLE OF DRAWING	ORG. NO. -
JAPAN INTERNATIONAL COOPERATION AGENCY	

1-1-4

<u>Item No.</u>	<u>15</u>
<u>Name</u>	<u>Double Face Hammer</u>
<u>Type</u>	<u>DSH-12</u>

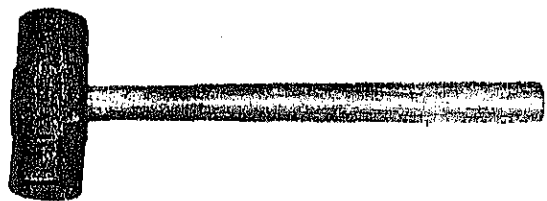

CONSTRUCTION PROJECT OF AUTOMOBILE REPAIR & MAINTENANCE WORKSHOP IN BANGLADESH	DATE
	SCALE
TITLE OF DRAWING	DRG. NO. —
JAPAN INTERNATIONAL COOPERATION AGENCY	

1-1-4

Item No. 16

Name Housing Dies

Type DP

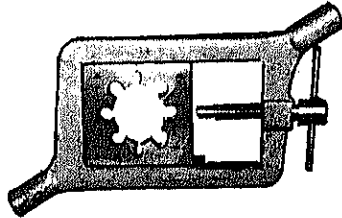

CONSTRUCTION PROJECT OF AUTOMOBILE REPAIR & MAINTENANCE WORKSHOP IN BANGLADESH	DATE
	SCALE
TITLE OF DRAWING	ORG. NO. —
JAPAN INTERNATIONAL COOPERATION AGENCY	

1-1-4
Item No. 17
Name Housing Dies
Type DP

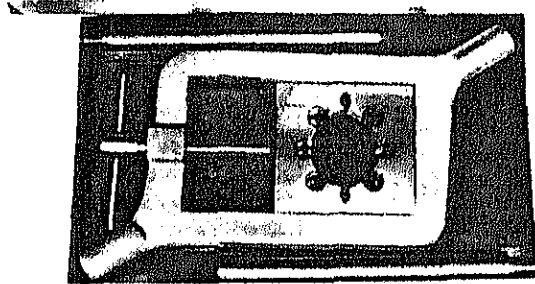

CONSTRUCTION PROJECT OF AUTOMOBILE REPAIR & MAINTENANCE WORKSHOP IN BANGLADESH		DATE
		SCALE
TITLE OF DRAWING		ORG. NO.
		-
JAPAN INTERNATIONAL COOPERATION AGENCY		

1-1-4

Item No. 19

Name Magnetic Base

Type YM-1

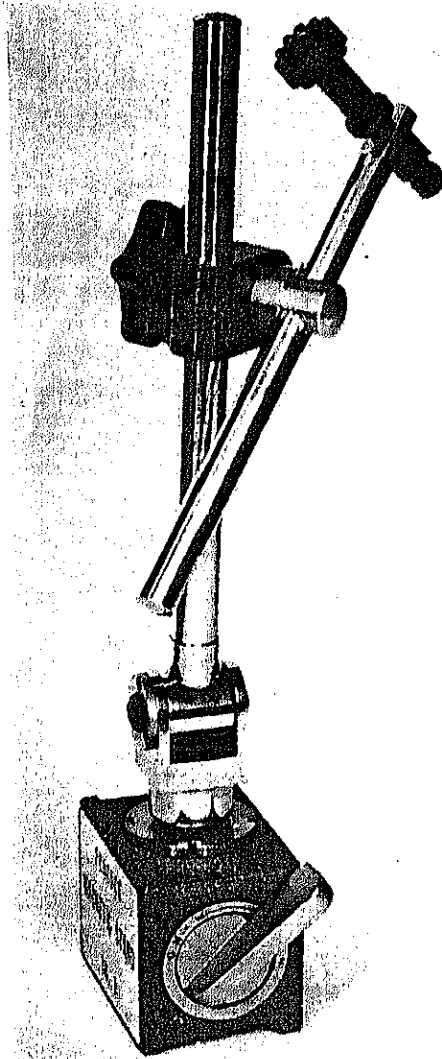

CONSTRUCTION PROJECT OF AUTOMOBILE REPAIR & MAINTENANCE WORKSHOP IN BANGLADESH	DATE
	SCALE
TITLE OF DRAWING	ORG. NO.
JAPAN INTERNATIONAL COOPERATION AGENCY	

1-1-4

Item No. 20

Name Dial Gauge

Type 1044

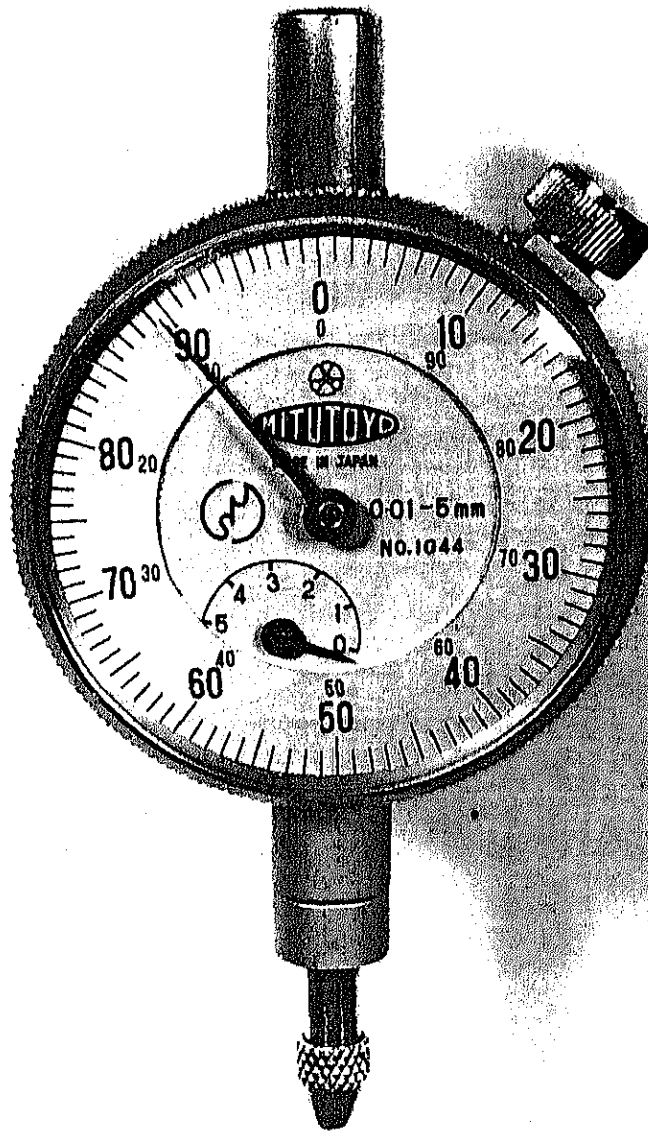

CONSTRUCTION PROJECT OF		DATE
AUTOMOBILE REPAIR & MAINTENANCE WORKSHOP IN BANGLADESH		SCALE
TITLE OF DRAWING		ORG. NO.
		-
JAPAN INTERNATIONAL COOPERATION AGENCY		

--- 1-1-4 ---

Item No. 21

Name Dial Gauge

Type No.2

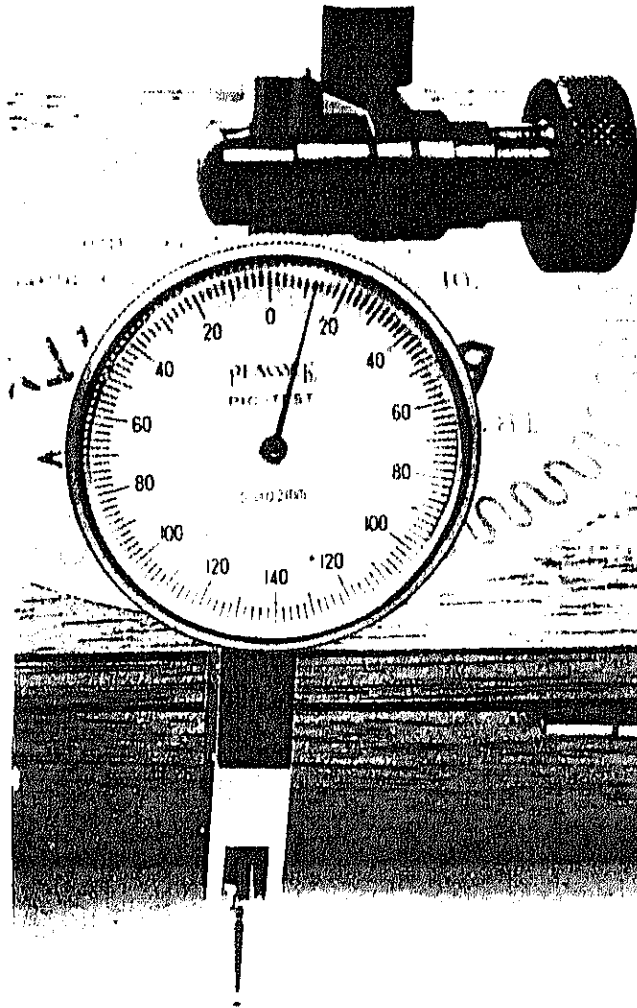

CONSTRUCTION PROJECT OF AUTOMOBILE REPAIR & MAINTENANCE WORKSHOP IN BANGLADESH	DATE
TITLE OF DRAWING	SCALE
	ORG. NO. —
JAPAN INTERNATIONAL COOPERATION AGENCY	

1-1-5) Group Engine Washing Shop & Engine Disassembling Shop

Item No.

1) Parts Washing Stand

Tank capacity: 55 lit - oil
45 lit - water
Discharge : 14 lit/min.
Motor : 200W, 1 - phase
Type WS-25
Refer to 1-1-2, Item No,5

2) Snap Ring Plier

Range: 10 - 60mm for stem
10 - 55mm for groove
Type SPS-4
Refer to 1-1-2, Item No,11

3) Steam Cleaner

Discharge: 1,600 lit/hour
Pressure : nominal 10 - 13kg/cm²
max. 20kg/cm²
Fuel consumption: 15 - 17 lit/hour
Motor: 1.5KW, 3 - phase
Fuel tank: 74 lit
Detergent tank: 100 lit
Capability of high pressure steam, cold water, hot water,
cleanings and low pressure steam and hot water cleanings
Type 1600

4) Air Impact Wrench

Bolt capacity: 16mm
Square drive: 12.7mm
Air pressure required: kg/cm²
with hose 10m, coupler and sockets for Mitsubishi and Isuzu
Type AW-1600 Refer to 1-1-3, Item No,34

Item No.	Qty
5) Hose With coupler and washing nozzle Type PWN-04	2
6) Auto Lift Capacity: 4 +4 ton Lifting: 1,500mm Air pressure required: 10kg/cm ² over Type WSL-80 Drawing No. G-001	4
7) Air Gun Weight: 800g Length: 76 x 80mm Type ABG-320 Refer to 1-1-2, Item No.12	7
8) Coupler Type PS-20	7
9) Hose Length: 10m Type CH-210	16
10) Air Impact Wrench Bolt capacity: 14mm Square drive: 12.7mm Air pressure required: with hose 10m, couple, sockets for Mitsubishi and Isuzu Type AW-1200	7

Item No.

Qty

11) Brush

16

Dimension: 250(W) x 1,350(L)mm
Type 250N

12) Engine Jack

10

Dimension: 1,600 x 1,400 x 1,000mm
with attachment for engine mounts
Type EOT-180

13) Tool Rack

3

Upper drawer: 290 x 320 x 50mm x 2
Middle drawer: 615 x 320 x 100mm
Low drawer: 615 x 320 x 120mm
Dimension: 740 x 400 x 840mm
Type TBC-32

14) Work Bench

1

Dimension: 1,780(W) x 600(D) x 750(H)mm
with two drawers
Type T-1000
Refer to 1-1-1, Item No.2

15) Vice

1

Jaw width: 150mm
Jaw opening: 155mm
Type UV-150
Refer to 1-1-1, Item No,3

16) Socket Wrench Set

1

Socket: 9 - 26mm 13 pcs.
Square drive: 12,7mm
with cross bar, extension bar and handles
Type No.30M

Item No.

Qty

17) Valve Lifter

6

Range: 50 - 225mm

Pinion rack type

Type VL-500

18) Wire Brush

10

Length: 310mm

with scraper

Type 765

19) Wire Brush

10

Length: 230mm

Type 766

20) Scraper

10

Length: 190mm

Type SB-19

21) Electric Pencil

1

Power: 1 - phase

Type EP-A

Refer to 1-1-3, Item No.40

22) Hand Tool

9

Consist of: open end wrench

6 x 7, 8 x 9, 10 x 12, 11 x 13, 12 x 14, 14 x 17,
19 x 21mm each 1 pc,

box wrench

8 x 9, 10 x 12, 11 x 13, 12 x 14, 14 x 17,
17 x 19, 19 x 21, 22 x 24mm each 1 pc,

flare nut wrench: 10 x 11, 12 x 14mm each 1 pc,

Item No.

Qty

socket wrench for 9.5/12.7mm
8, 9, 10, 11, 12, 13, 14, 17, 19, 21, 22, 23,
24mm each 1 pc.
ratchet handle, nut spinner handle, sliding T
handle, extension bars, universal joint, plug
wrench for 9.5/12.7mm, adjustable wrench 250mm,
plier 200, 150mm, nippler 150mm, hammer 450g
- driver 75, 100, 150, 200mm
+ driver 75, 100, 150mm: stubby driver -, +
integral handle driver 280mm; thickness gauge,
plug gap gauge, flat chisel, center punch, needle
file set, point file with case
socket wrench (No.44S)
8 - 32mm 21 pcs. for 12.7mm
ratchet handle, extension bars, sliding T handle,
universal joint, speeder handle with case

Type CU-405/CU-305/No.44S

23) Engine Trolley

10

Dimension: 1,700(L) x 900(W) x 700(H)mm

Load: 800kg

Type EC-1000

24) Impact Driver

3

With (-) bit and (+) bit each 3 pcs.

Type #2600

Refer to 1-1-3, Item No.41

25) Pin Punch

1

Tip dia.: 3.2mm

Length: 130mm

Type C-25

Item No.	Qty
26) Pin Punch Tip dia.: 4mm Length: 150mm Type C-26	1
27) Pin Punch Tip dia.: 4.5mm Length: 150mm Type C-27	1
28) Pin Punch Tip dia.: 6.3mm Length: 150mm Type C-28	1
29) Pin Punch Tip dia.: 8mm Length: 180mm Type C-29	1
30) Impact Driver With (-) bit and bit each 3 pcs. Type #2600 Refer to 1-1-3, Item No.41	3
31) Writing Table Dimension: 1,000(W) x 700(D) x 700(H)mm with seat Type 3616DL/2218ZZ Refer to 1-1-1, Item No.8	1

1-1-5

Item No. 3

Name Steam Cleaner

Type 1600

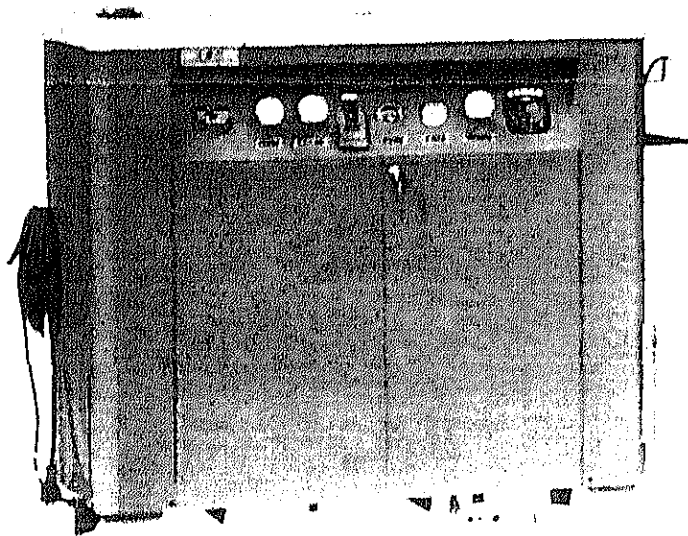

CONSTRUCTION PROJECT OF AUTOMOBILE REPAIR & MAINTENANCE WORKSHOP IN BANGLADESH	DATE
	SCALE
TITLE OF DRAWING	ORG. NO. —
JAPAN INTERNATIONAL COOPERATION AGENCY	

1-1-5

Item No. 5

Name Hose

Type PWN-04

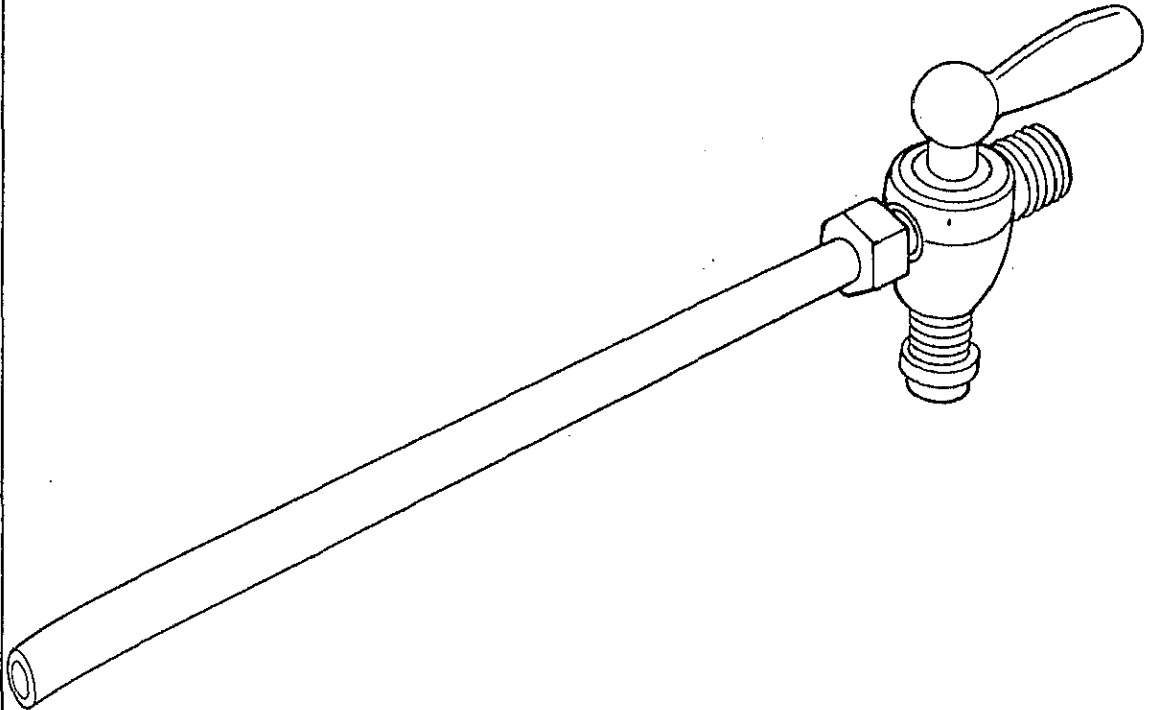

CONSTRUCTION PROJECT OF		DATE
AUTOMOBILE REPAIR & MAINTENANCE WORKSHOP IN BANGLADESH		SCALE
TITLE OF DRAWING		DRG. NO. —
JAPAN INTERNATIONAL COOPERATION AGENCY		

1-1-5

Item No. 6-1/2

Name Auto Lift

Type WSL-80

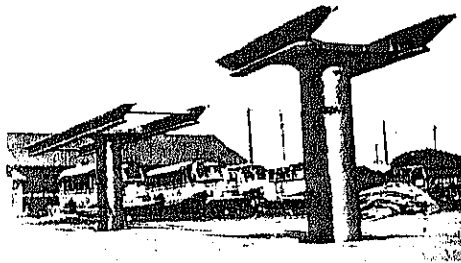
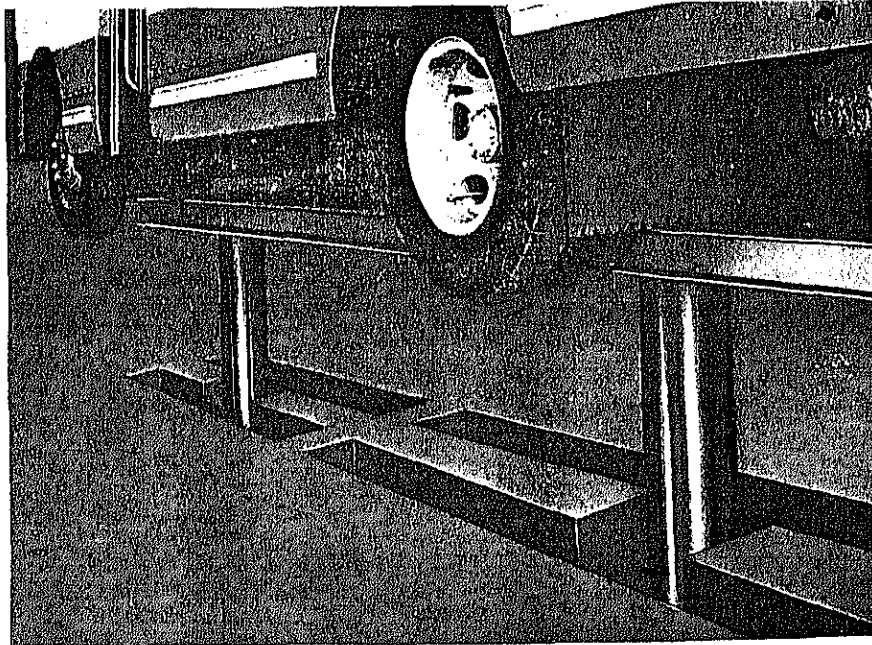

CONSTRUCTION PROJECT OF AUTOMOBILE REPAIR & MAINTENANCE WORKSHOP IN BANGLADESH	DATE
	SCALE
TITLE OF DRAWING	ORG. NO. —
JAPAN INTERNATIONAL COOPERATION AGENCY	

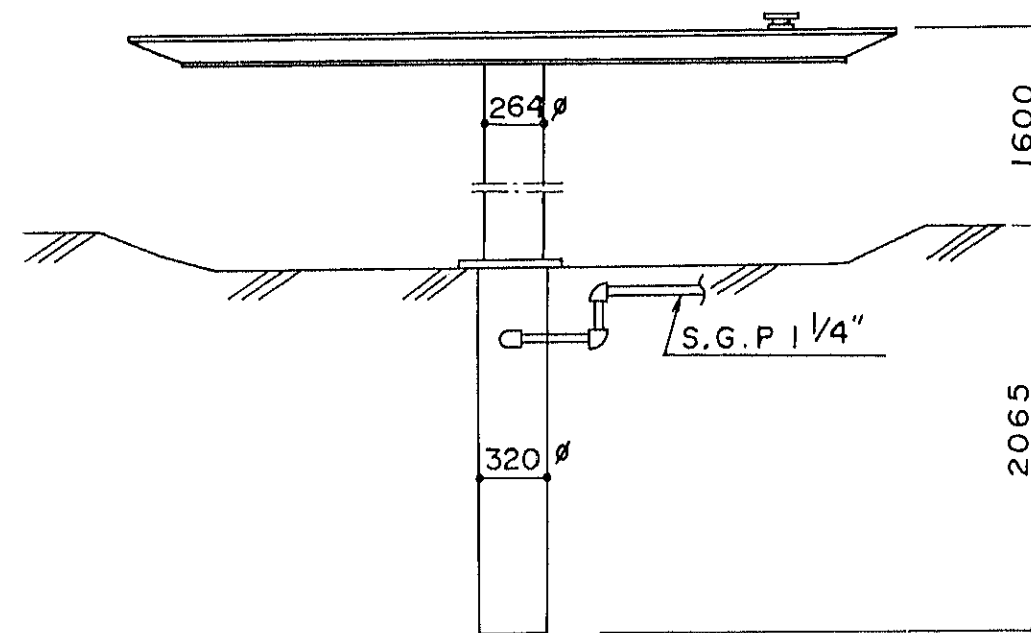
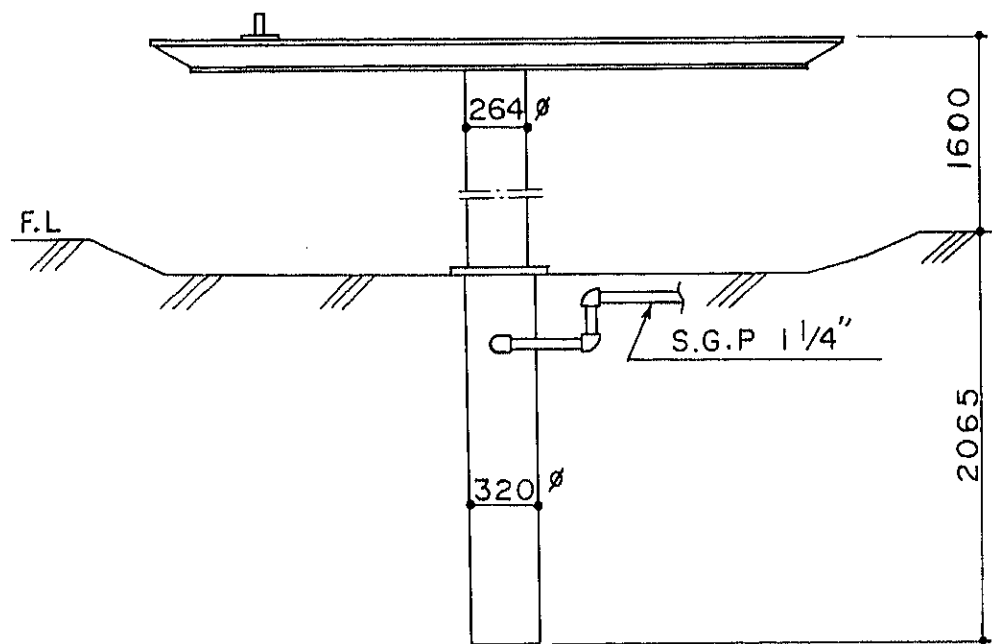
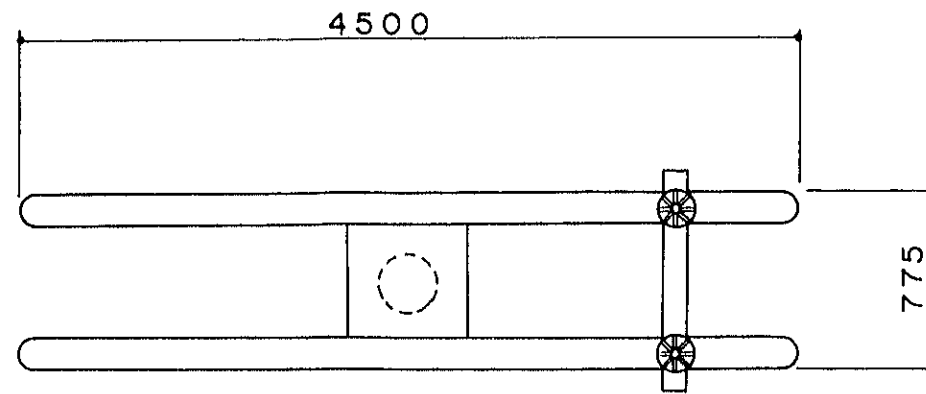
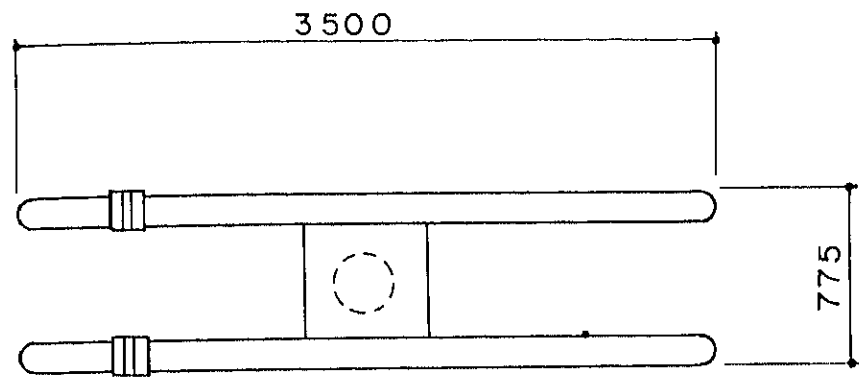

1-1-5
 Item NO. 6-2/2
 Name Auto Lift
 Type WSL-80

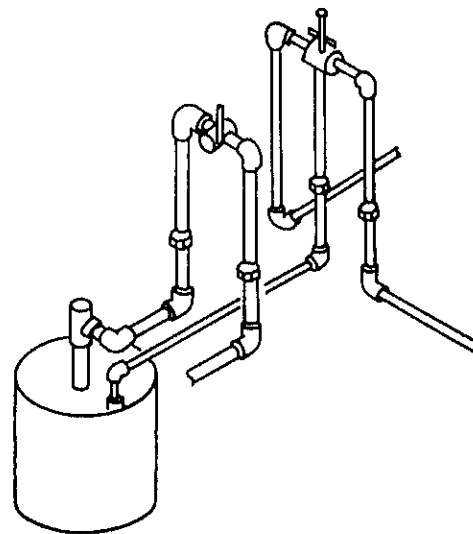

OIL TANK AND CONTROL VALVE

CONSTRUCTION PROJECT OF AUTOMOBILE REPAIR & MAINTENANCE WORKSHOP IN BANGLADESH		DATE
TITLE OF DRAWING AUTO LIFT		SCALE
		DR G. NO G - 001
JAPAN INTERNATIONAL COOPERATION AGENCY		

1-1-5

Item No.	8
Name	Coupler
Type	PS-20

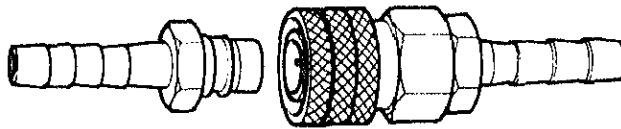

CONSTRUCTION PROJECT OF AUTOMOBILE REPAIR & MAINTENANCE WORKSHOP IN BANGLADESH	DATE
	SCALE
TITLE OF DRAWING	ORG. NO.
JAPAN INTERNATIONAL COOPERATION AGENCY	

1-1-5

Item No.	9
Name	Hose
Type	CH-210

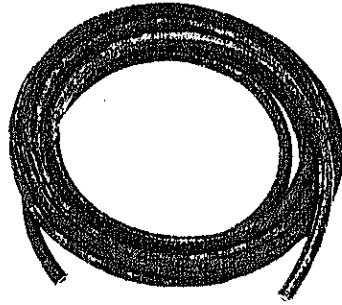

CONSTRUCTION PROJECT OF AUTOMOBILE REPAIR & MAINTENANCE WORKSHOP IN BANGLADESH	DATE
	SCALE
TITLE OF DRAWING	DRG. NO. —
JAPAN INTERNATIONAL COOPERATION AGENCY	

1-1-5

Item No. 10

Name Air Impact Wrench

Type AW-1200

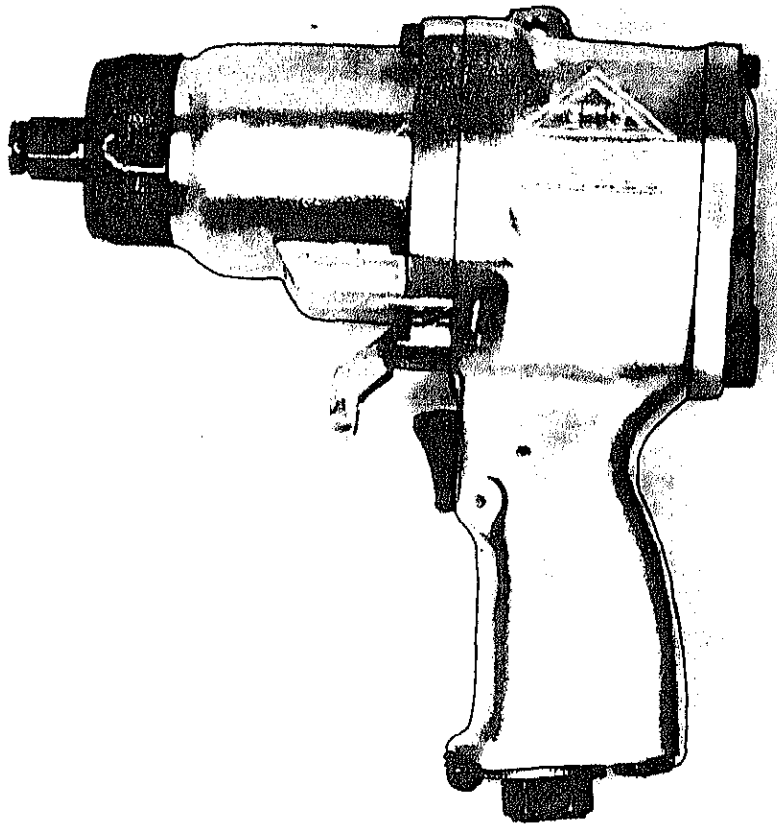

CONSTRUCTION PROJECT OF		DATE
AUTOMOBILE REPAIR & MAINTENANCE WORKSHOP IN BANGLADESH		SCALE
TITLE OF DRAWING		ORG. NO.
		-
JAPAN INTERNATIONAL COOPERATION AGENCY		

1-1-5

Item No. 11

Name Brush

Type 250N



CONSTRUCTION PROJECT OF AUTOMOBILE REPAIR & MAINTENANCE WORKSHOP IN BANGLADESH	DATE
	SCALE
TITLE OF DRAWING	DRG. NO. —
JAPAN INTERNATIONAL COOPERATION AGENCY	

1-1-5

Item No.	12
Name	Engine Jack
Type	EOT-180

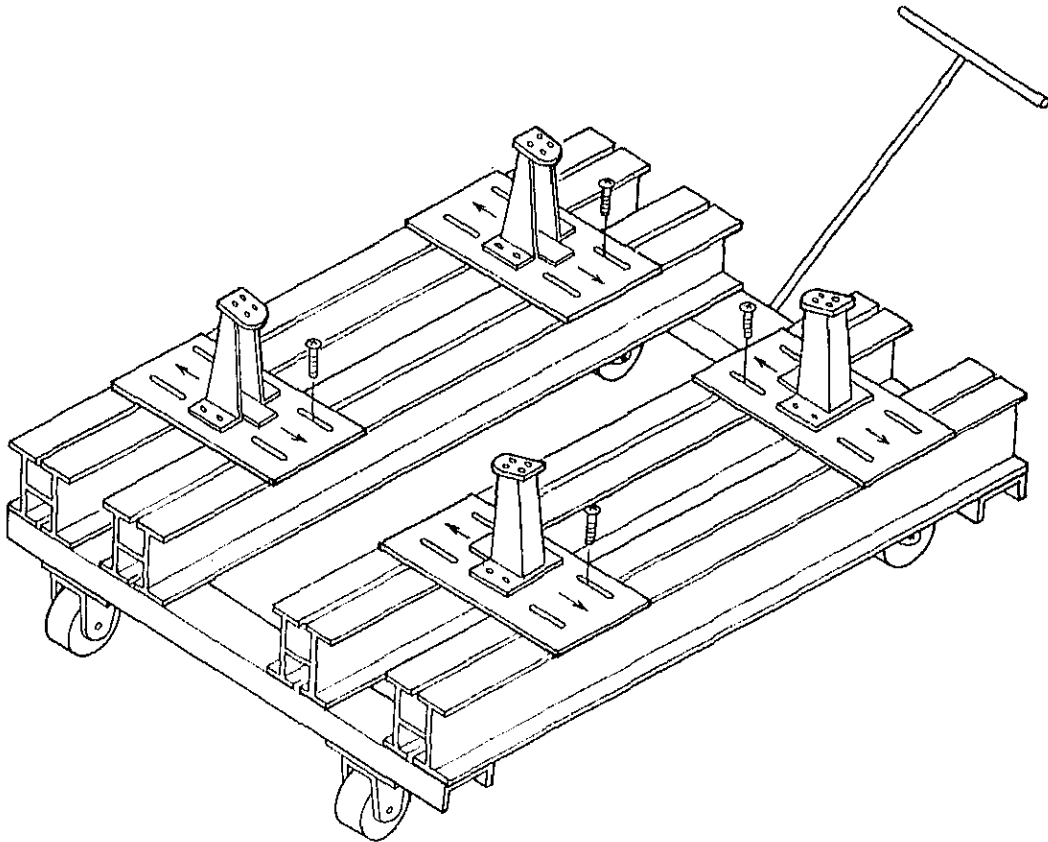

CONSTRUCTION PROJECT OF AUTOMOBILE REPAIR & MAINTENANCE WORKSHOP IN BANGLADESH	DATE
	SCALE
TITLE OF DRAWING	ORG. NO. —
JAPAN INTERNATIONAL COOPERATION AGENCY	

1-1-5

Item No.	13
Name	Tool Rack
Type	TBC-32

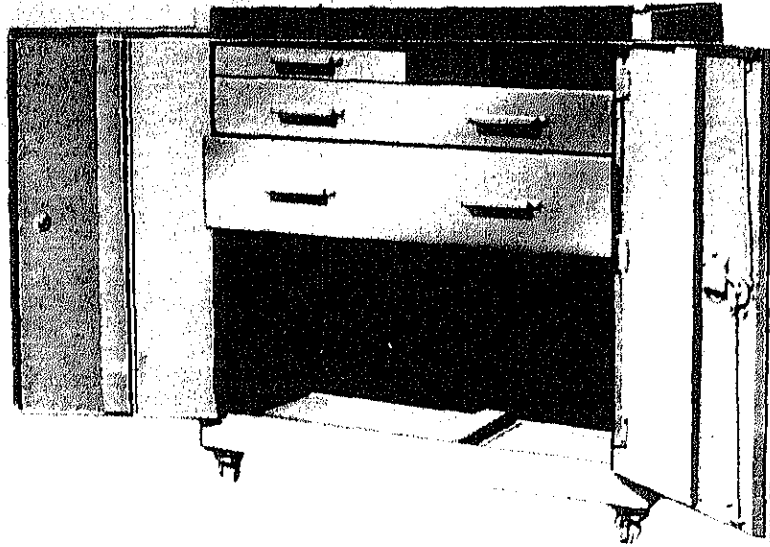

CONSTRUCTION PROJECT OF AUTOMOBILE REPAIR & MAINTENANCE WORKSHOP IN BANGLADESH	DATE
	SCALE
TITLE OF DRAWING	ORG. NO. —
JAPAN INTERNATIONAL COOPERATION AGENCY	

1-1-5

Item No. 16

Name Socket Wrench Set

Type No.30M

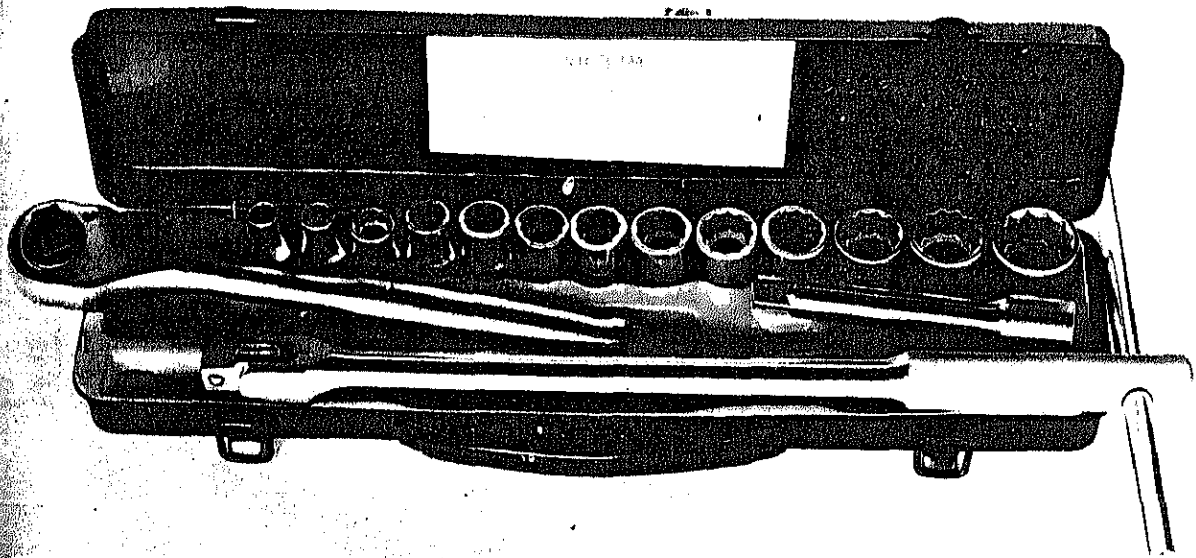

CONSTRUCTION PROJECT OF AUTOMOBILE REPAIR & MAINTENANCE WORKSHOP IN BANGLADESH	DATE
	SCALE
TITLE OF DRAWING	ORG. NO. —
JAPAN INTERNATIONAL COOPERATION AGENCY	

---1-1-5---

Item No. 17

Name Valve Lifter

Type VL-500

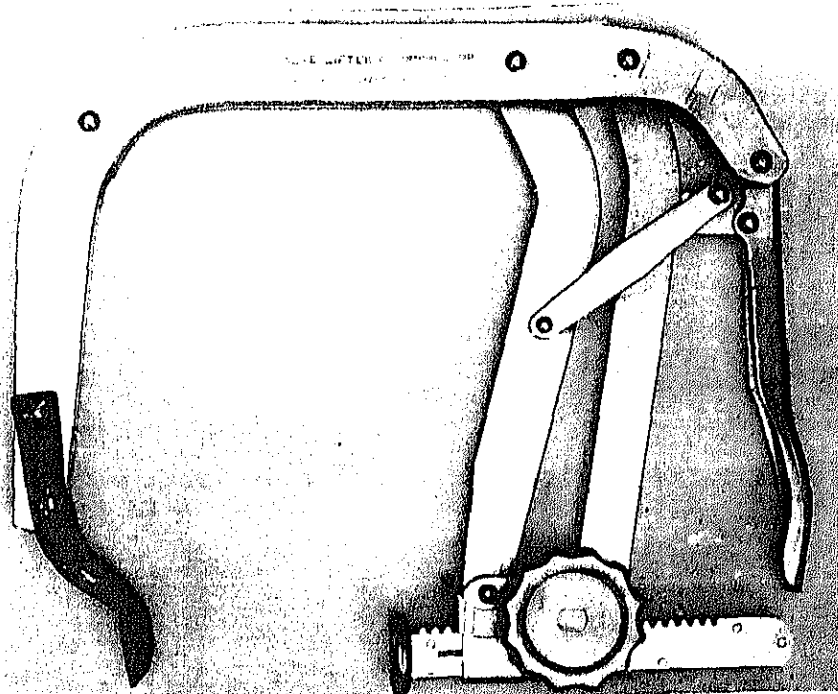

CONSTRUCTION PROJECT OF AUTOMOBILE REPAIR & MAINTENANCE WORKSHOP IN BANGLADESH		DATE
TITLE OF DRAWING		SCALE
		DRG. NO. —
JAPAN INTERNATIONAL COOPERATION AGENCY		

1-1-5

Item No. 18

Name Wire Brush

Type 765

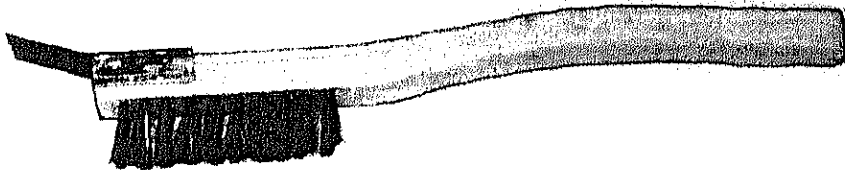

CONSTRUCTION PROJECT OF AUTOMOBILE REPAIR & MAINTENANCE WORKSHOP IN BANGLADESH	DATE
	SCALE
TITLE OF DRAWING	DRG. NO. —
JAPAN INTERNATIONAL COOPERATION AGENCY	

1-1-5

Item No. 19

Name Wire Brush

Type 766

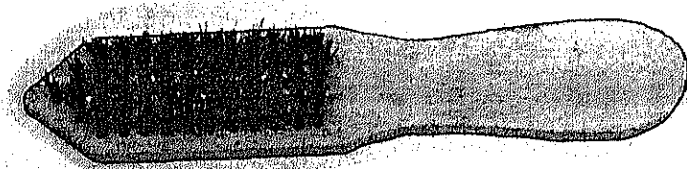

CONSTRUCTION PROJECT OF AUTOMOBILE REPAIR & MAINTENANCE WORKSHOP IN BANGLADESH	DATE
	SCALE
TITLE OF DRAWING	ORG. NO. —
JAPAN INTERNATIONAL COOPERATION AGENCY	

1-1-5

Item No. 20

Name Scraper

Type SB-19

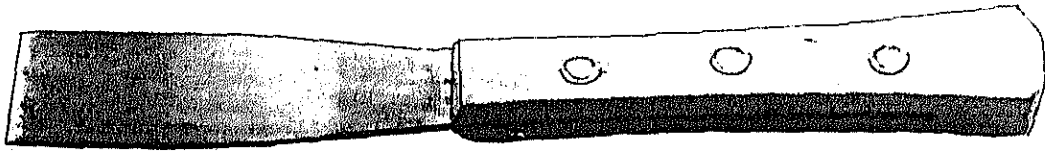

CONSTRUCTION PROJECT OF		DATE
AUTOMOBILE REPAIR & MAINTENANCE WORKSHOP IN BANGLADESH		SCALE
TITLE OF DRAWING		ORG. NO.
JAPAN INTERNATIONAL COOPERATION AGENCY		

--- 1-1-5 ---

Item No. 22

Name Hand Tool

Type CU-405/CU-305/No.44S

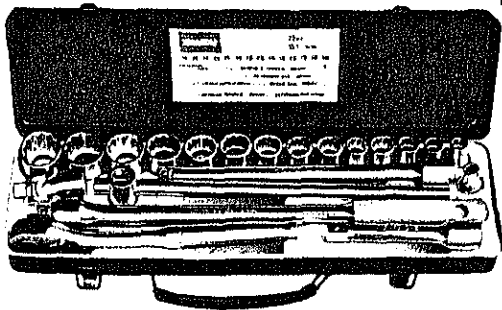
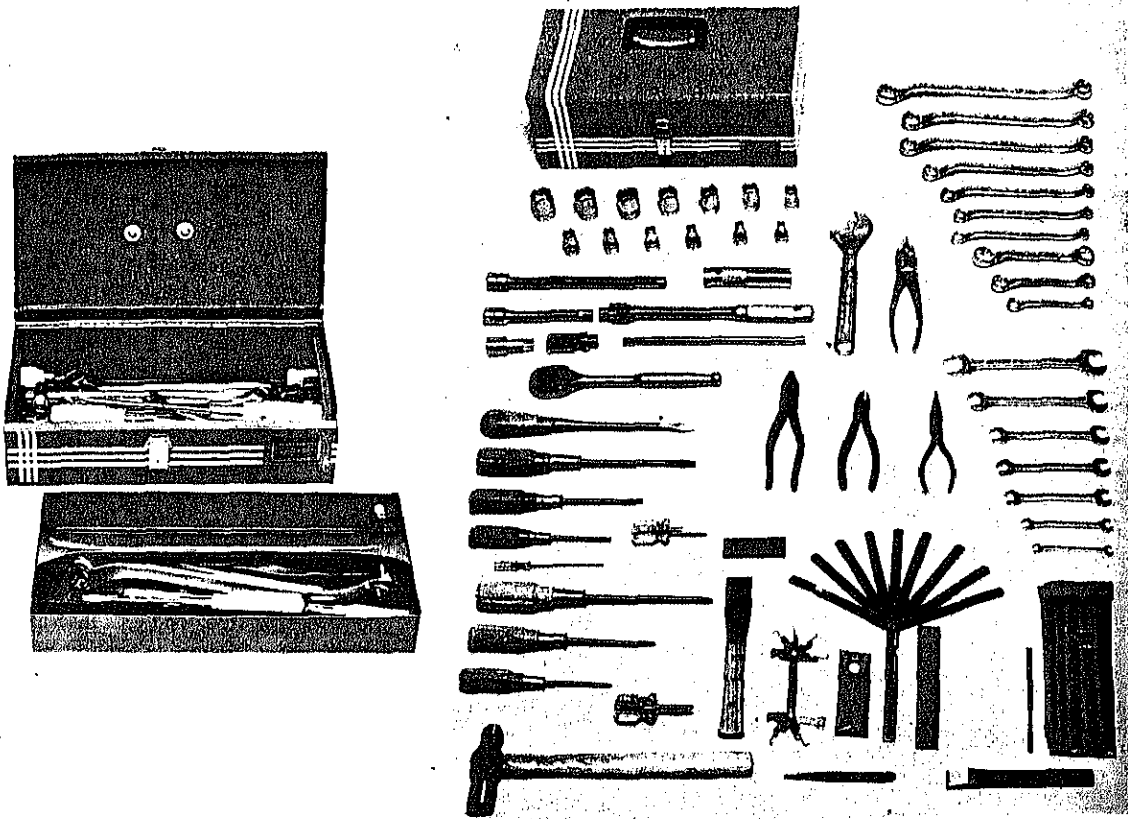

CONSTRUCTION PROJECT OF		DATE
AUTOMOBILE REPAIR & MAINTENANCE WORKSHOP IN BANGLADESH		SCALE
TITLE OF DRAWING		ORG. NO.
JAPAN INTERNATIONAL COOPERATION AGENCY		

1-1-5

Item No. 23

Name Engine Trolley

Type EC-1000

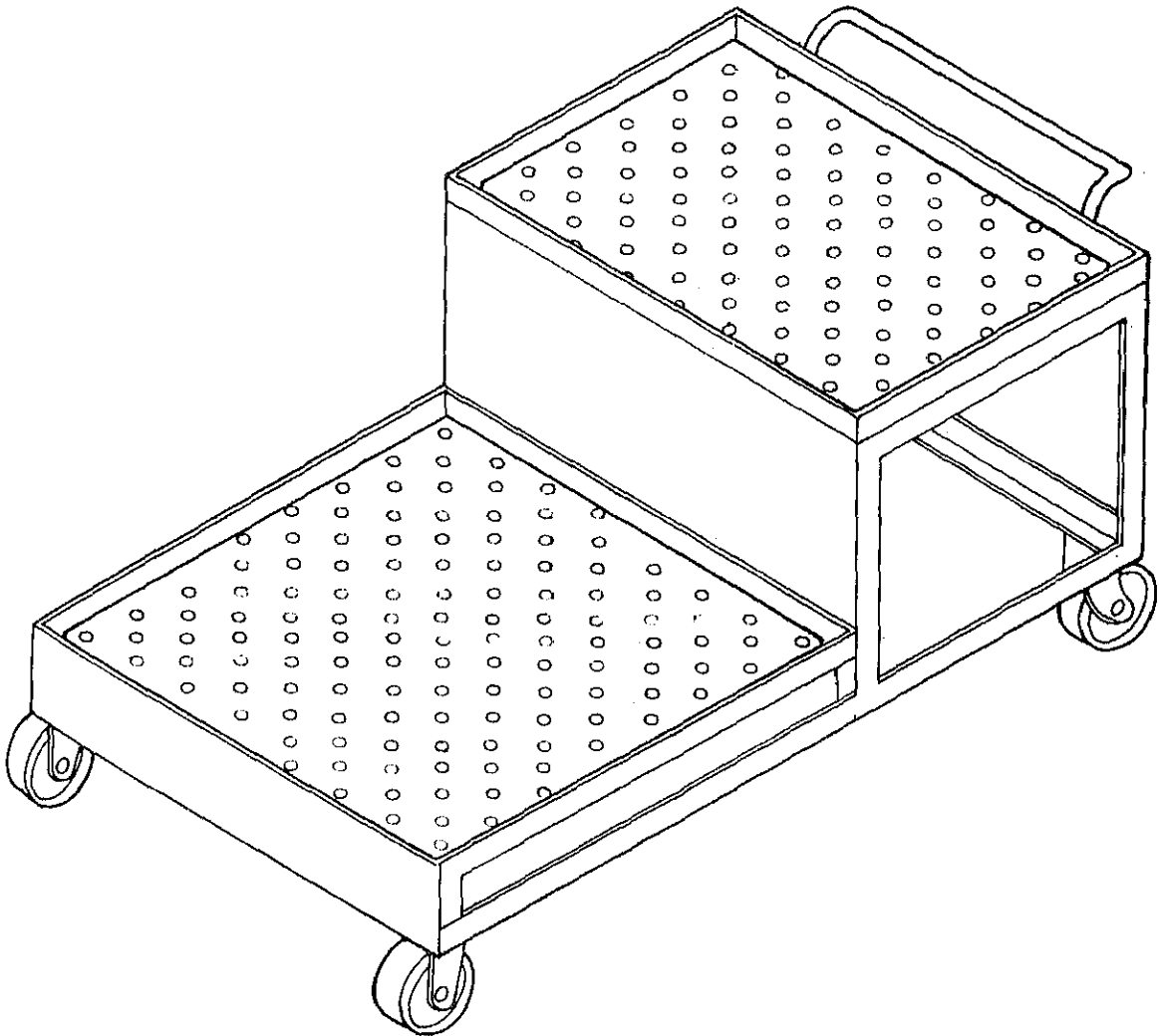

CONSTRUCTION PROJECT OF		DATE
AUTOMOBILE REPAIR & MAINTENANCE WORKSHOP IN BANGLADESH		SCALE
TITLE OF DRAWING		ORG. NO.
		—
JAPAN INTERNATIONAL COOPERATION AGENCY		

1-1-5

Item No. 25

Name Pin Punch

Type C-25



CONSTRUCTION PROJECT OF AUTOMOBILE REPAIR & MAINTENANCE WORKSHOP IN BANGLADESH	DATE
	SCALE
TITLE OF DRAWING	DRG. NO. —
JAPAN INTERNATIONAL COOPERATION AGENCY	

1-1-5

Item No. 26

Name Pin Punch

Type C-26



CONSTRUCTION PROJECT OF AUTOMOBILE REPAIR & MAINTENANCE WORKSHOP IN BANGLADESH	DATE
	SCALE
TITLE OF DRAWING	DRG. NO. —
JAPAN INTERNATIONAL COOPERATION AGENCY	

1-1-5

Item No. 27
Name Pin Punch
Type C-27



CONSTRUCTION PROJECT OF AUTOMOBILE REPAIR & MAINTENANCE WORKSHOP IN BANGLADESH	DATE
	SCALE
TITLE OF DRAWING	ORG. NO. —
JAPAN INTERNATIONAL COOPERATION AGENCY	

1-1-5

Item No. 28

Name Pin Punch

Type C-28



CONSTRUCTION PROJECT OF AUTOMOBILE REPAIR & MAINTENANCE WORKSHOP IN BANGLADESH		DATE
TITLE OF DRAWING		SCALE
		ORG. NO.
JAPAN INTERNATIONAL COOPERATION AGENCY		

---1-1-5---

Item No. 29

Name Pin Punch

Type C-29



CONSTRUCTION PROJECT OF		DATE
AUTOMOBILE REPAIR & MAINTENANCE WORKSHOP IN BANGLADESH		SCALE
TITLE OF DRAWING		DRG. NO.
JAPAN INTERNATIONAL COOPERATION AGENCY		

1-1-6) Group Engine Assembling Shop

Item No.		Qty
1)	Parts Washing Stand	10
	Tank capacity: 55 lit - oil	
	45 lit - water	
	Discharge: 45 lit/min.	
	Motor: 200W, 1 - phase	
	Type WS-25	
	Refer to 1-1-2, Item No.5	
2)	Working Table	10
	Dimension: 800(L) x 1,800(W) x 510(H)mm	
	Covered with oil resistance rubber	
	Type WT-80	
3)	Tool Stand	10
	Dimension: 620(W) x 460(D) x 800(H)mm	
	Interchangeable tray: 4 - steps	
	Type TS-34	
	Refer to 1-1-1, Item No.10	
4)	Tool Stand	10
	Dimension: 620(W) x 460(D) x 800(H)mm	
	Interchangeable tray: 4 - steps	
	Type TS-34	
	Refer to 1-1-1, Item No.10	
5)	Tool Cabinet	5
	Dimension: 740 x 400 x 1,220mm	
	ten drawers	
	Type TB-100B	

Item No.	Qty
6) Piston Ring Compressor Capacity: 75 - 175mm Type RC-30	5
7) Piston Ring Filing Tool Length: 310mm Type RT-40	5
8) Piston Ring Tool Length: 150mm Type RT-45	10
9) Torque Wrench Range: 200 - 1,300kgf.cm Size: 12.7mm Type 1300F	5
10) Torque Wrench Range: 500 - 2,800kgf.cm Size: 19mm Type 2800F Refer to 1-1-4, Item No.7	5
11) Torque Wrench Range: 1,000 - 5,600kgf.cm Size: 19mm Type 5600F	5
12) Fuel Tank Tank capacity: 100 lit Type FT-100	10

Item No.	Qty
13) Radiator, Fan Combination Dimension: 900 x 700 x 1,000mm Motor: 0.75KW, 3 - phase Type ECS-60	10
14) Exhaust System Dimension: 60 ϕ x 2,000(L)mm with heat resisting property duct and attachment Type EES-60	10
15) Battery Carrier Dimension: 900 x 600 x 850mm with 200AH battery 2 sets and accessories Type BC-200	4
16) Jib Crane Capacity: 2 ton Beam length: 3m Hoist height: 3m Type JP-2	5
17) Sling Chain Capacity: 1 x 2 ton Type ID-SS	5
18) Oil Separator Set Dimension: 650 x 550 x 820mm Type PS-550	10
19) T Wrench Size: 8mm Type TW-8	10

Item No.

- 20) T Wrench
Size: 9mm
Type TW-9
- 21) T Wrench
Size: 10mm
Type TW-10
- 22) T Wrench
Size: 11mm
Type TW-11
- 23) T Wrench
Size: 12mm
Type TW-12
- 24) T Wrench
Size: 13mm
Type TW-13
- 25) T Wrench
Size: 14mm
Type TW-14
- 26) T Wrench
Size: 17mm
Type TW-17
- 27) T Wrench
Size: 19mm
Type TW-19

10
10
10
10
10
10
10
10

Item No.

28) T Wrench

Size: 21mm

Type TW-21

29) T Wrench

Size: 23mm

Type TW-23

30) Hex. Wrench

Size: 1.27 - 3.0mm 5 pcs./set

Type AW-50

31) Hex. Wrench

Size: 3 - 17mm 9 pcs./set

Type AW-90

32) Hex. Wrench

Size: 5/32 - 5/8 9 pcs./set

Type AW-100

33) Copper Hammer

Weight: 900g

Type CH-32

34) Soft Hammer

Weight: 1,000g

Type SPH-10

35) Tool set

Consist of: open end wrench

6 x 7, 8 x 9, 10 x 12, 11 x 13, 12 x 14,

14 x 17, 19 x 21mm each 1 pc.

Item No.

box wrench

8 x 9, 10 x 12, 11 x 13, 12 x 14, 14 x 17,
19 x 21, 22 x 24mm each 1 pc.

flare nut wrench: 10 x 11, 12 x 14mm each 1 pc.

socket wrench for 9.5/12.7mm

8, 9, 10, 11, 12, 13, 14, 17, 19, 21, 22, 23
24mm each 1 pc,

ratchet handle, nut spinner handle, sliding T
handle, extension bars, universal joint, plug
wrench for 9.5/12.7mm, adjustable wrench 250mm,

plier 200, 150mm, nipper 150mm, hammer 450g,
- driver 75, 100, 150, 200mm

+ driver 75, 100, 150mm: stubby driver -, +
integral handle driver 280mm, thickness gauge,
plug gap gauge, flat chisel, center punch,
needle file set, point file with case

Type CU-405/CU-305

36) Writing Table

Dimension: 1,000(W) x 700(D) x 700(H)mm

with seat

Type 3616DL/2218ZZ

Refer to 1-1-1, Item No.8

37) Snap Ring Plier Set

Range: 0 - 16mm for stem

0 - 55mm for groove

Type SPS-4

Refer to 1-1-2, Item No.11

38) Air Gun

Weight: 0.8kg Length: 76 + 80mm L type

with PS coupler, nipple and hose 5m

Item No.

Type ABG-320

Refer to 1-1-2, Item No.12

39) Oiler Set

Oil drum pump mounted on dolly

Equipped with siphon, dis-pensing hose and grip meter
(E-18-230) 1 - 10 lit

Pump (KP-110): pneumatic type with air regulator
cylinder dia.: 110mm
capacity: 5.5 lit/min.

Air pressure required: max, 7kg/cm²

Type AL-205

Refer to 1-1-3, Item No,25

40) Working Lamp

Cord length: 7.7m

Type WL-30

Refer to 1-1-2, Item No.7

1-1-6

Item No. 2

Name Working Table

Type WT-80

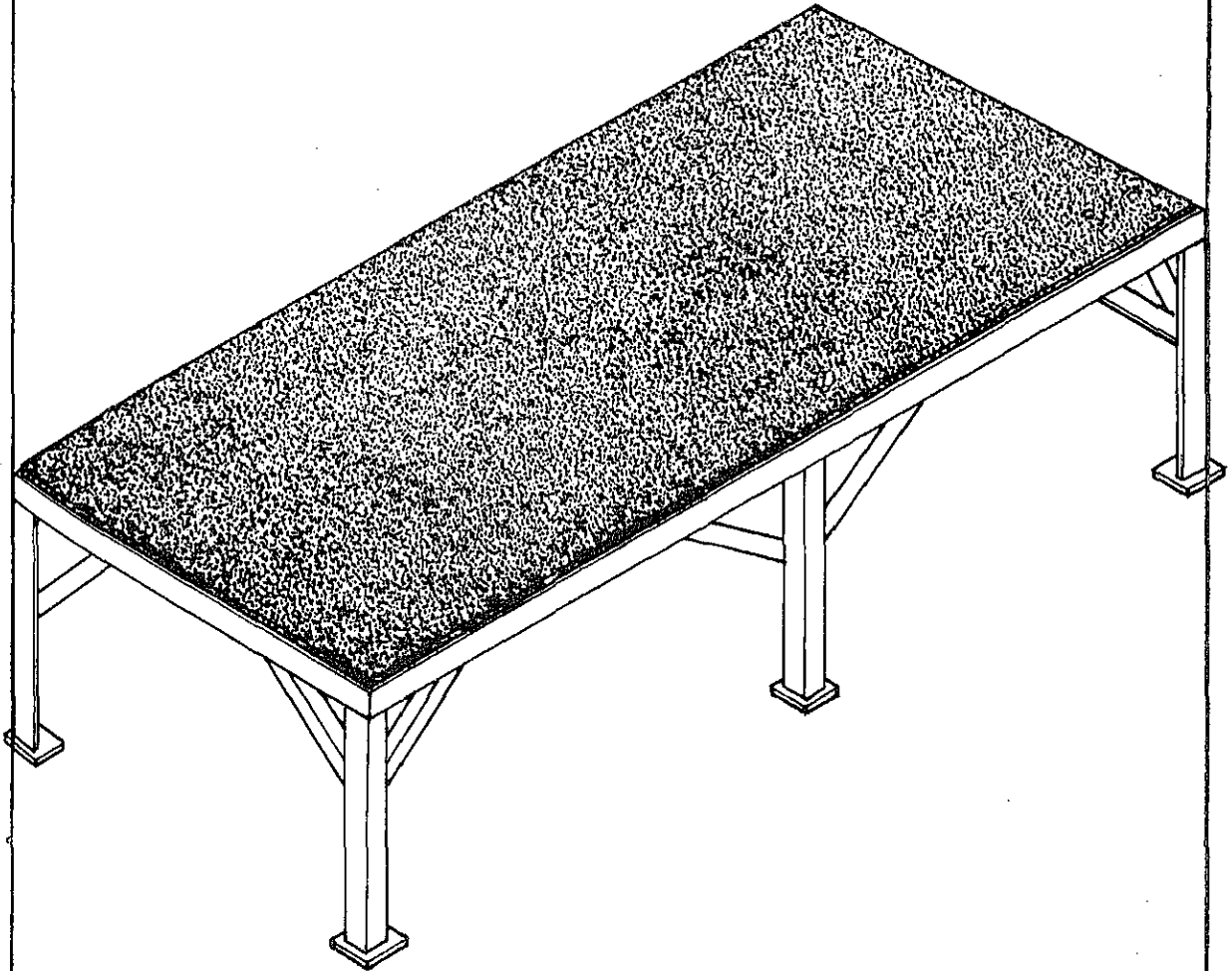

CONSTRUCTION PROJECT OF AUTOMOBILE REPAIR & MAINTENANCE WORKSHOP IN BANGLADESH	DATE
	SCALE
TITLE OF DRAWING	DRG. NO. —
JAPAN INTERNATIONAL COOPERATION AGENCY	

1-1-6

Item No. 5

Name Tool Cabinet

Type TB-100B



CONSTRUCTION PROJECT OF AUTOMOBILE REPAIR & MAINTENANCE WORKSHOP IN BANGLADESH	DATE
	SCALE
TITLE OF DRAWING	ORG. NO. —
JAPAN INTERNATIONAL COOPERATION AGENCY	

1-1-6

Item No. 6

Name Piston Ring Compressor

Type RC-30

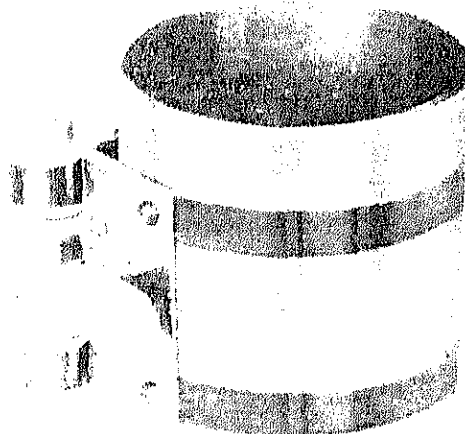

CONSTRUCTION PROJECT OF AUTOMOBILE REPAIR & MAINTENANCE WORKSHOP IN BANGLADESH	DATE
TITLE OF DRAWING	SCALE
	DRG. NO. —
JAPAN INTERNATIONAL COOPERATION AGENCY	

1-1-6

Item No. 7

Name Piston Ring Filing Tool

Type RT-40

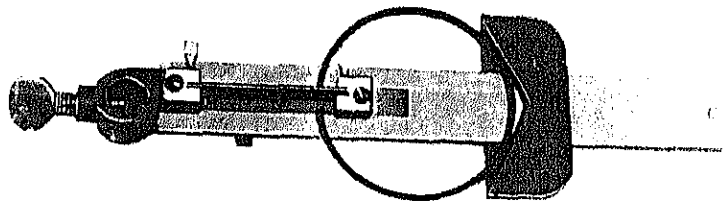

CONSTRUCTION PROJECT OF		DATE
AUTOMOBILE REPAIR & MAINTENANCE WORKSHOP IN BANGLADESH		SCALE
TITLE OF DRAWING		ORG. NO.
		-
JAPAN INTERNATIONAL COOPERATION AGENCY		

1-1-6

Item No. 3

Name Piston Ring Tool

Type RT-45

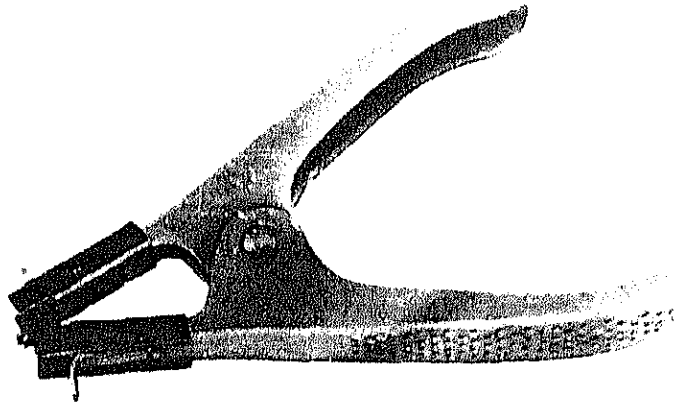

CONSTRUCTION PROJECT OF AUTOMOBILE REPAIR & MAINTENANCE WORKSHOP IN BANGLADESH	DATE
	SCALE
TITLE OF DRAWING	ORG. NO. —
JAPAN INTERNATIONAL COOPERATION AGENCY	

1-1-6

Item No. 9

Name Toque Wrench

Type 1300F

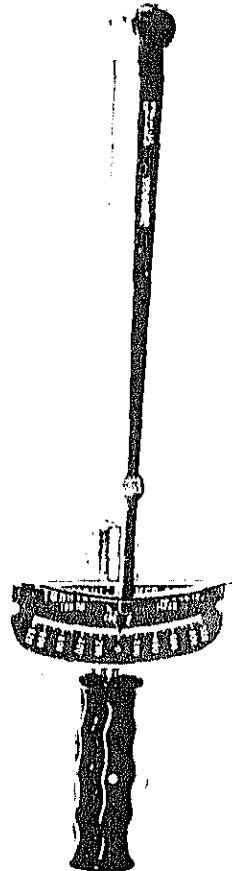

CONSTRUCTION PROJECT OF		DATE
AUTOMOBILE REPAIR & MAINTENANCE WORKSHOP IN BANGLADESH		SCALE
TITLE OF DRAWING		ORG. NO.
JAPAN INTERNATIONAL COOPERATION AGENCY		—

---1-1-6---

Item No. 11

Name Torque Wrench

Type 5600F



CONSTRUCTION PROJECT OF		DATE
AUTOMOBILE REPAIR & MAINTENANCE WORKSHOP IN BANGLADESH		SCALE
TITLE OF DRAWING		DRG. NO.
JAPAN INTERNATIONAL COOPERATION AGENCY		-

---1-1-6---

Item No. 12

Name Fuel Tank

Type FT-100

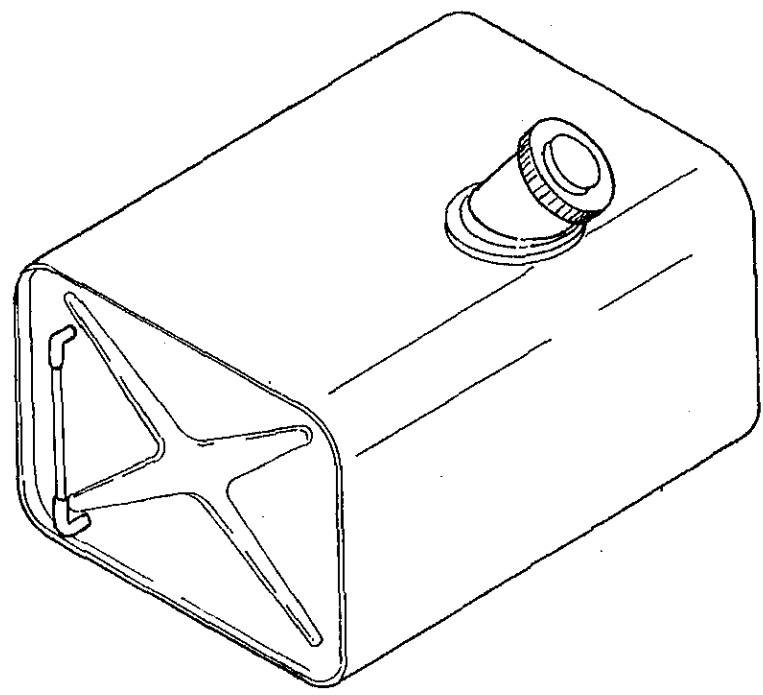

CONSTRUCTION PROJECT OF AUTOMOBILE REPAIR & MAINTENANCE WORKSHOP IN BANGLADESH		DATE
TITLE OF DRAWING		SCALE
		ORG. NO.
JAPAN INTERNATIONAL COOPERATION AGENCY		-

1-1-6

Item No. 13

Name Radiator, Fan Combination

Type ECS-60

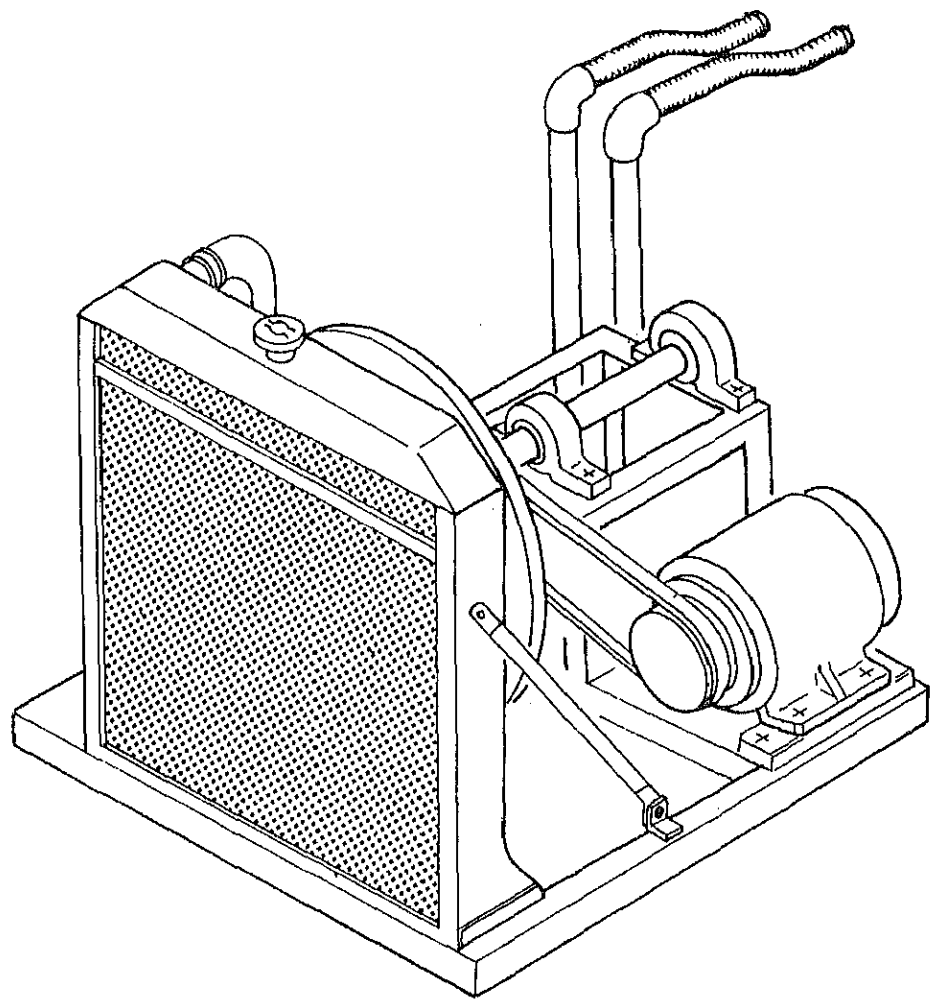

CONSTRUCTION PROJECT OF	DATE
AUTOMOBILE REPAIR & MAINTENANCE WORKSHOP IN BANGLADESH	SCALE
TITLE OF DRAWING	DRG. NO. —
JAPAN INTERNATIONAL COOPERATION AGENCY	

---1-1-6---

Item No. 14

Name Exhaust System

Type EES-60

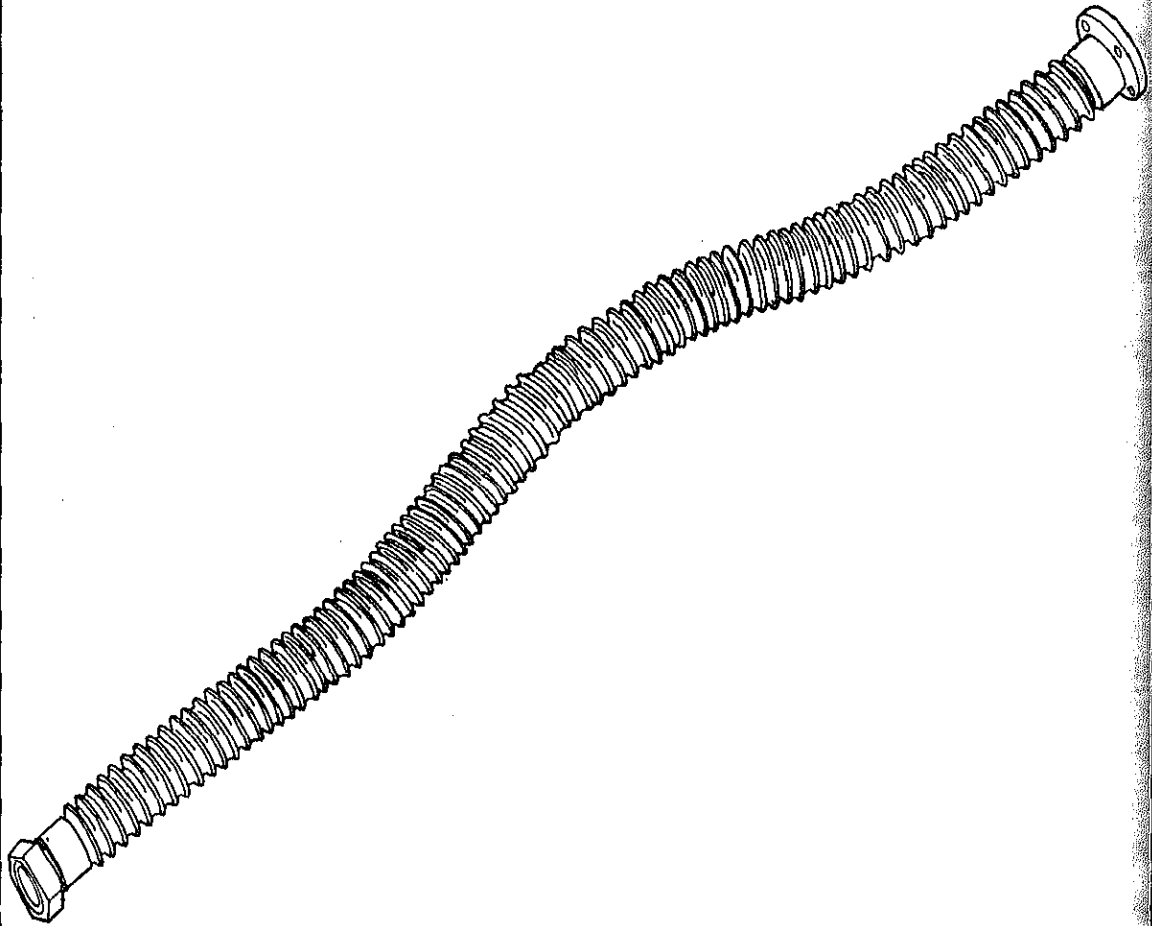

CONSTRUCTION PROJECT OF AUTOMOBILE REPAIR & MAINTENANCE WORKSHOP IN BANGLADESH	DATE
	SCALE
TITLE OF DRAWING	ORG. NO. —
JAPAN INTERNATIONAL COOPERATION AGENCY	

1-1-6

Item No. 15

Name Battery Carrier

Type BC-200

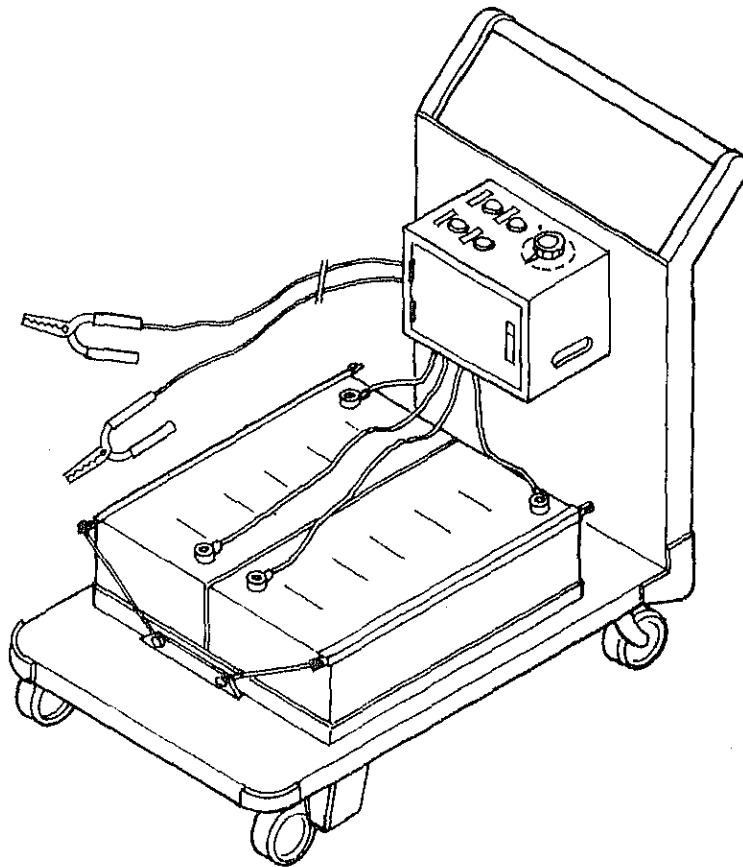

CONSTRUCTION PROJECT OF AUTOMOBILE REPAIR & MAINTENANCE WORKSHOP IN BANGLADESH	DATE
	SCALE
TITLE OF DRAWING	DRG. NO. —
JAPAN INTERNATIONAL COOPERATION AGENCY	

1-1-6

Item No.	16
Name	Jib Crane
Type	JP-2

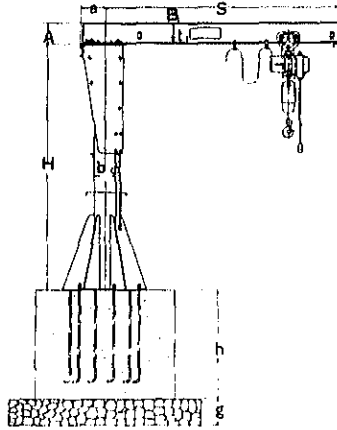

CONSTRUCTION PROJECT OF AUTOMOBILE REPAIR & MAINTENANCE WORKSHOP IN BANGLADESH	DATE
	SCALE
TITLE OF DRAWING	ORG. NO.
JAPAN INTERNATIONAL COOPERATION AGENCY	

1-1-6

Item No. 17

Name Sling Chain

Type 1D-SS

Double Type

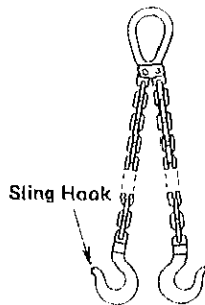

D-SS

CONSTRUCTION PROJECT OF AUTOMOBILE REPAIR & MAINTENANCE WORKSHOP IN BANGLADESH	DATE
	SCALE
TITLE OF DRAWING	ORG. NO.
JAPAN INTERNATIONAL COOPERATION AGENCY	

1-1-6

Item No. 18

Name Oil Separater Set

Type PS-550

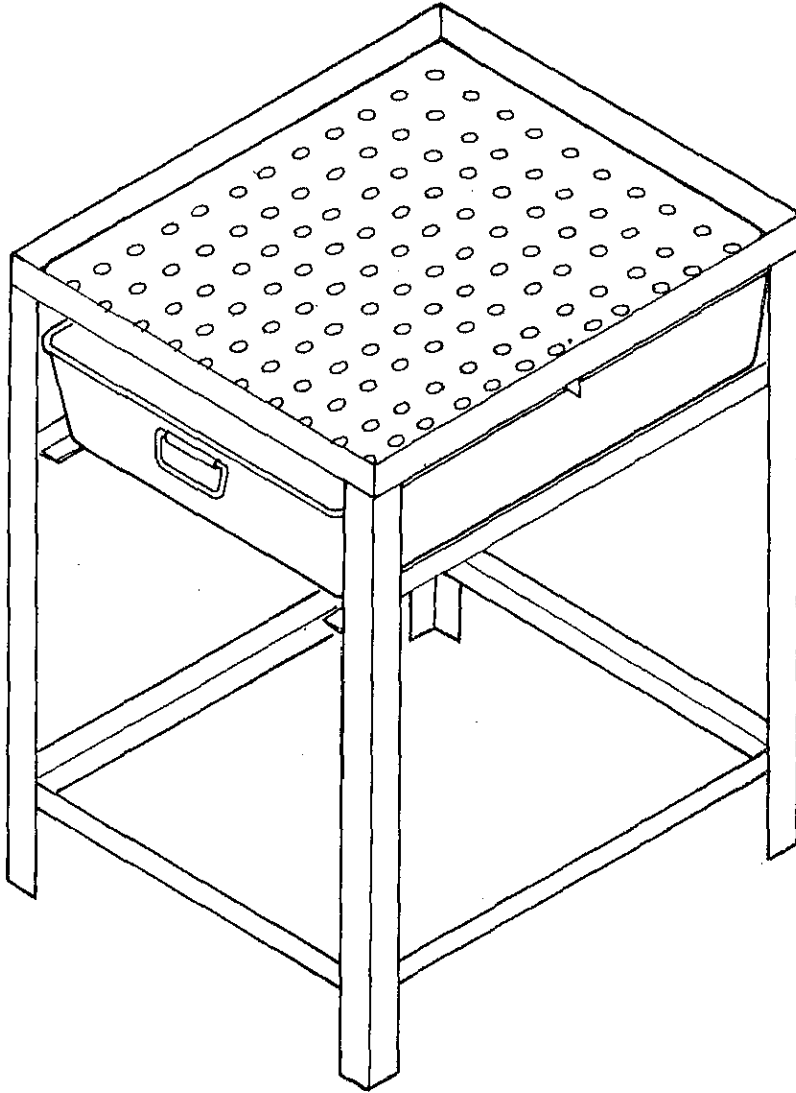

CONSTRUCTION PROJECT OF AUTOMOBILE REPAIR & MAINTENANCE WORKSHOP IN BANGLADESH	DATE
	SCALE
TITLE OF DRAWING	ORG. NO. —
JAPAN INTERNATIONAL COOPERATION AGENCY	

1-1-6

Item No.	19
Name	T Wrench
Type	TW-8

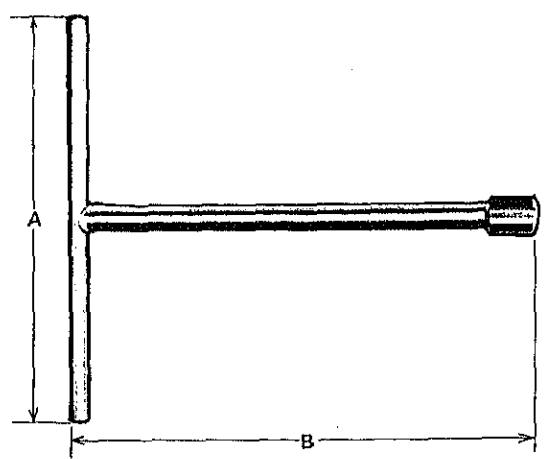

CONSTRUCTION PROJECT OF AUTOMOBILE REPAIR & MAINTENANCE WORKSHOP IN BANGLADESH	DATE
	SCALE
TITLE OF DRAWING	DRG. NO. -
JAPAN INTERNATIONAL COOPERATION AGENCY	

1-1-6

Item No. 20

Name T Wrench

Type TW-9

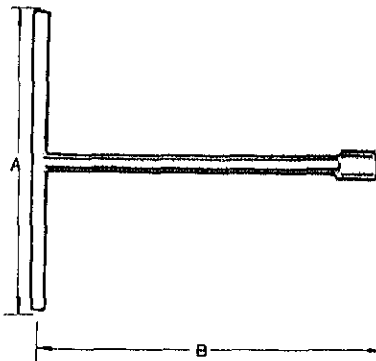

CONSTRUCTION PROJECT OF	DATE
AUTOMOBILE REPAIR & MAINTENANCE WORKSHOP IN BANGLADESH	SCALE
TITLE OF DRAWING	ORG. NO. —
JAPAN INTERNATIONAL COOPERATION AGENCY	

1-1-6

Item No. 21

Name T Wrench

Type TW-10

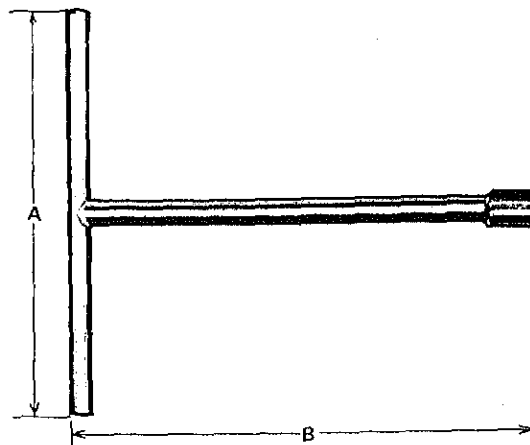

CONSTRUCTION PROJECT OF AUTOMOBILE REPAIR & MAINTENANCE WORKSHOP IN BANGLADESH		DATE
TITLE OF DRAWING		SCALE
		DRG. NO. -
JAPAN INTERNATIONAL COOPERATION AGENCY		

1-1-6

Item No. 22

Name T Wrench

Type TW-11

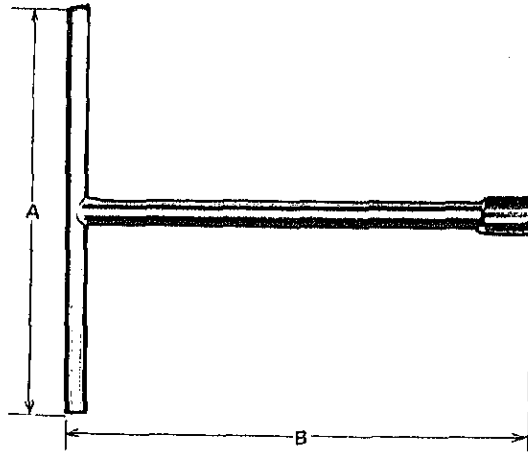

CONSTRUCTION PROJECT OF AUTOMOBILE REPAIR & MAINTENANCE WORKSHOP IN BANGLADESH	DATE
	SCALE
TITLE OF DRAWING	DRG. NO. —
JAPAN INTERNATIONAL COOPERATION AGENCY	

1-1-6

Item No.	23
Name	T Wrench
Type	TW-12

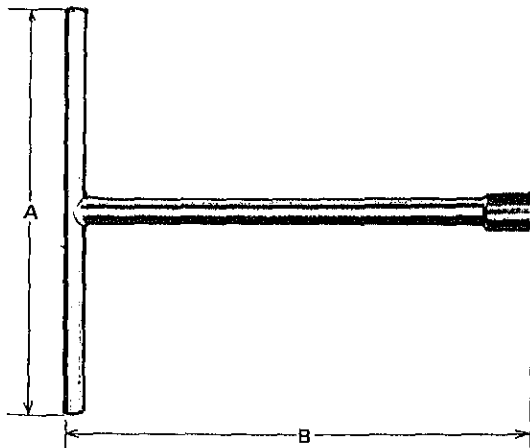

CONSTRUCTION PROJECT OF AUTOMOBILE REPAIR & MAINTENANCE WORKSHOP IN BANGLADESH	DATE
	SCALE
TITLE OF DRAWING	DRG. NO. —
JAPAN INTERNATIONAL COOPERATION AGENCY	

1-1-6

Item No. 24

Name T Wrench

Type TW-13

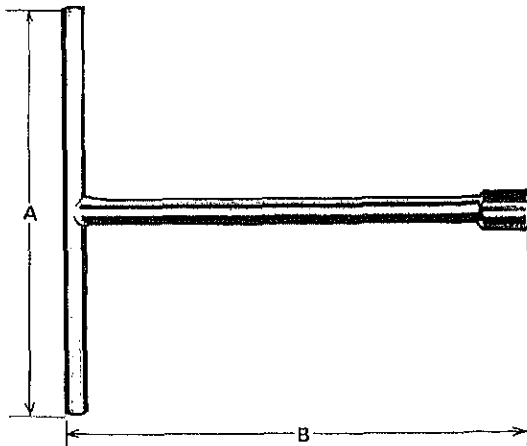

CONSTRUCTION PROJECT OF AUTOMOBILE REPAIR & MAINTENANCE WORKSHOP IN BANGLADESH	DATE
	SCALE
TITLE OF DRAWING	ORG. NO.
JAPAN INTERNATIONAL COOPERATION AGENCY	

1-1-6

Item No.	25
Name	T Wrench
Type	TW-14

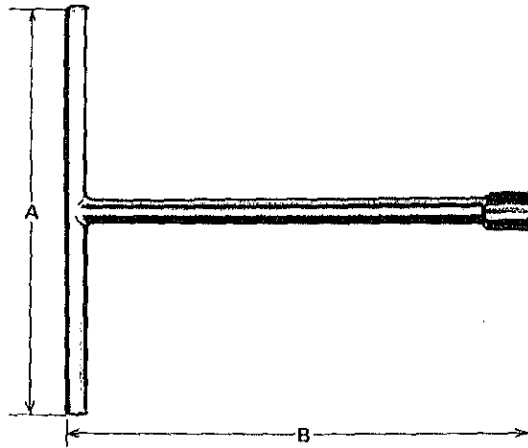

CONSTRUCTION PROJECT OF AUTOMOBILE REPAIR & MAINTENANCE WORKSHOP IN BANGLADESH	DATE
	SCALE
TITLE OF DRAWING	DRG. NO. —
JAPAN INTERNATIONAL COOPERATION AGENCY	

1-1-6

Item No. 26

Name T Wrench

Type TW-17

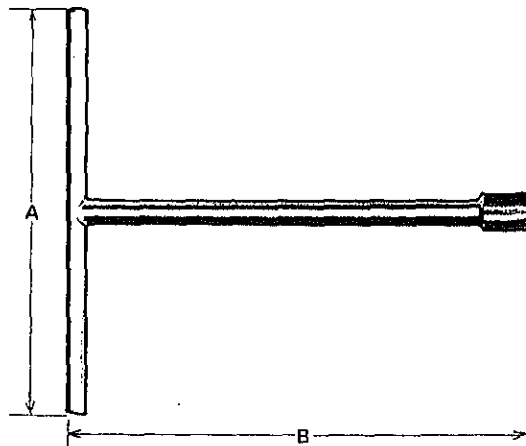

CONSTRUCTION PROJECT OF	DATE
AUTOMOBILE REPAIR & MAINTENANCE WORKSHOP IN BANGLADESH	SCALE
TITLE OF DRAWING	ORG. NO. —
JAPAN INTERNATIONAL COOPERATION AGENCY	

1-1-6

Item No. 27

Name T Wrench

Type TW-19

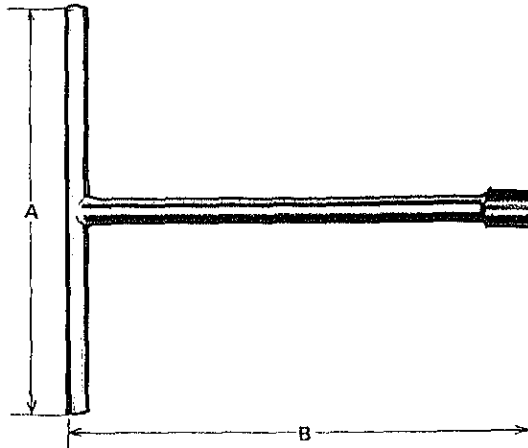

CONSTRUCTION PROJECT OF AUTOMOBILE REPAIR & MAINTENANCE WORKSHOP IN BANGLADESH	DATE
	SCALE
TITLE OF DRAWING	ORG. NO. —
JAPAN INTERNATIONAL COOPERATION AGENCY	

---1-1-6---

Item No. 28

Name T Wrench

Type TW-21

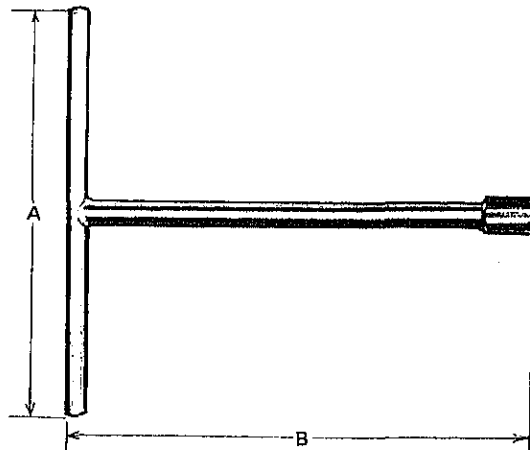

CONSTRUCTION PROJECT OF AUTOMOBILE REPAIR & MAINTENANCE WORKSHOP IN BANGLADESH	DATE
	SCALE
TITLE OF DRAWING	ORG. NO. —
JAPAN INTERNATIONAL COOPERATION AGENCY	

1-1-6

Item No. 29

Name T Wrench

Type TW-23

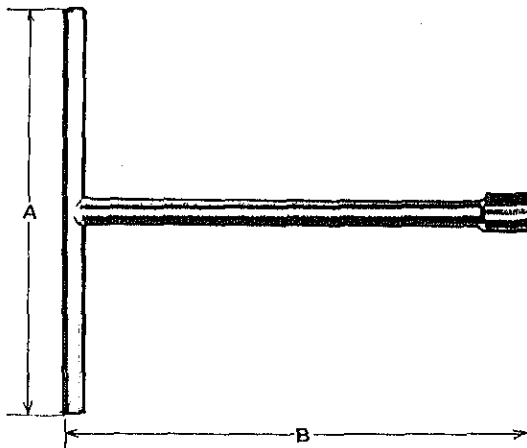

CONSTRUCTION PROJECT OF AUTOMOBILE REPAIR & MAINTENANCE WORKSHOP IN BANGLADESH	DATE
	SCALE
TITLE OF DRAWING	ORG. NO.
JAPAN INTERNATIONAL COOPERATION AGENCY	

1-1-6

Item No. 30

Name Hex. Wrench

Type AW-50



CONSTRUCTION PROJECT OF		DATE
AUTOMOBILE REPAIR & MAINTENANCE WORKSHOP IN BANGLADESH		SCALE
TITLE OF DRAWING		DRG. NO. —
JAPAN INTERNATIONAL COOPERATION AGENCY		

1-1-6
Item No. 31
Name Hex. Wrench
Type AW-90

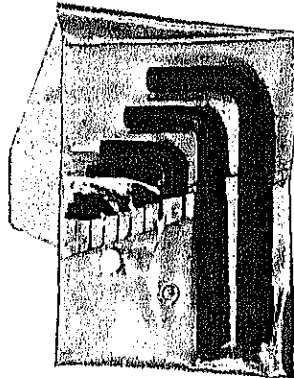

CONSTRUCTION PROJECT OF AUTOMOBILE REPAIR & MAINTENANCE WORKSHOP IN BANGLADESH	DATE
	SCALE
TITLE OF DRAWING	ORG. NO.
JAPAN INTERNATIONAL COOPERATION AGENCY	

1-1-6

Item No.	32
Name	Hex. Wrench
Type	AW-100

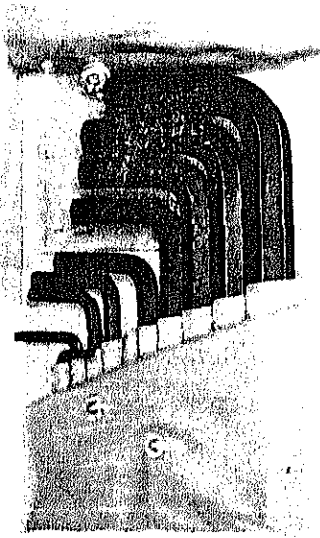

CONSTRUCTION PROJECT OF AUTOMOBILE REPAIR & MAINTENANCE WORKSHOP IN BANGLADESH	DATE
	SCALE
TITLE OF DRAWING	ORG. NO. —
JAPAN INTERNATIONAL COOPERATION AGENCY	

1-1-6

Item No. 33

Name Copper Hammer

Type CH-32

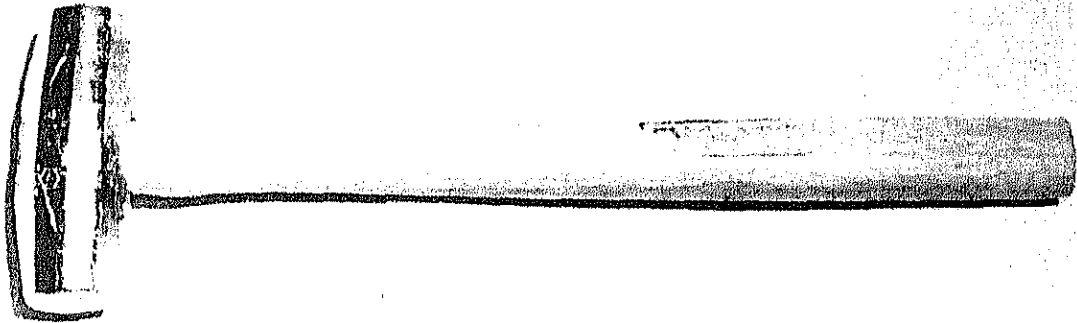

CONSTRUCTION PROJECT OF		DATE
AUTOMOBILE REPAIR & MAINTENANCE WORKSHOP IN BANGLADESH		SCALE
TITLE OF DRAWING		ORG. NO.
JAPAN INTERNATIONAL COOPERATION AGENCY		

1-1-6

Item NO. 34
Name Soft Hammer
Type SPH-10



CONSTRUCTION PROJECT OF		DATE
AUTOMOBILE REPAIR & MAINTENANCE WORKSHOP IN BANGLADESH		SCALE
TITLE OF DRAWING		DRG. NO.
JAPAN INTERNATIONAL COOPERATION AGENCY		

1-1-6

Item No. 35

Name Tool Set

Type CU-405/CU-305

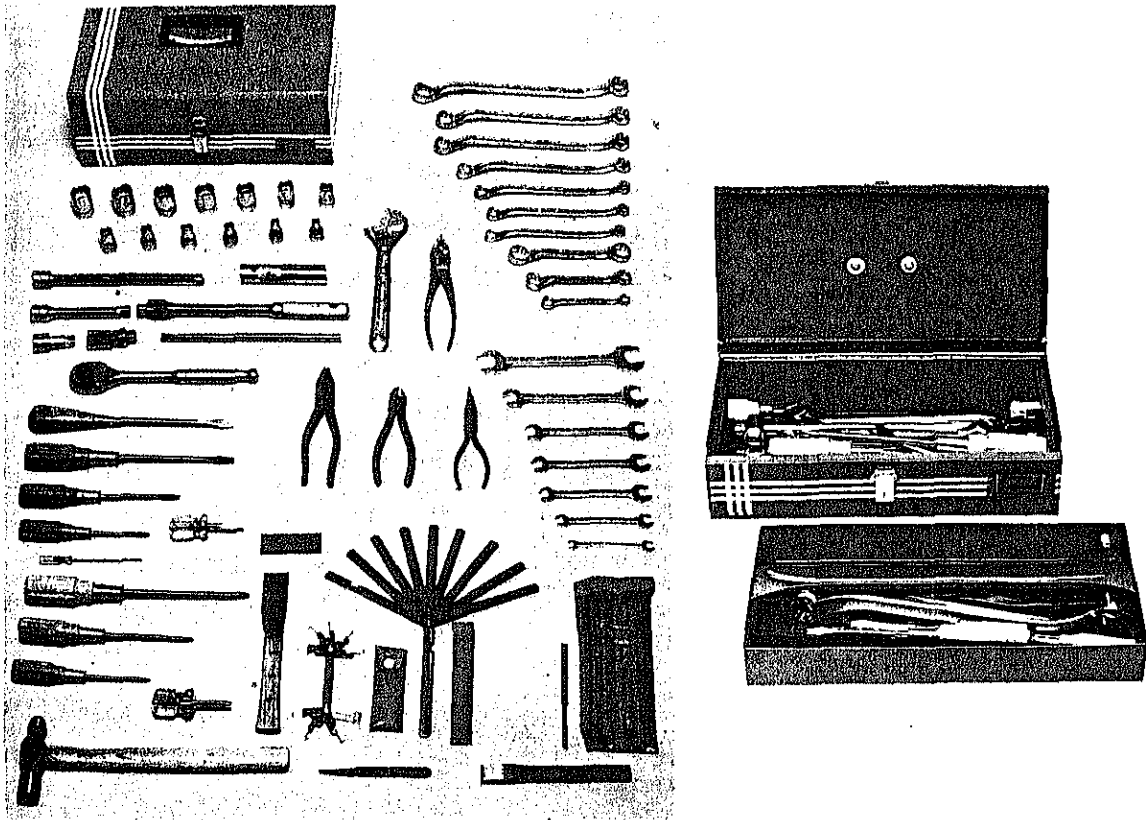

CONSTRUCTION PROJECT OF AUTOMOBILE REPAIR & MAINTENANCE WORKSHOP IN BANGLADESH	DATE
	SCALE
TITLE OF DRAWING	DRG. NO. —
JAPAN INTERNATIONAL COOPERATION AGENCY	