

THE PEOPLE'S REPUBLIC OF BANGLADESH
DETAILED DESIGN REPORT
ON
CONSTRUCTION PROJECT
OF
AUTOMOBILE REPAIR & MAINTENANCE WORKSHOP
VOLUME—4

JICA LIBRARY



1181660 [0]

OCTOBER 1978

Japan International Cooperation Agency

MPI

78-25/(4/6)

THE PEOPLE'S REPUBLIC OF BANGLADESH
DETAILED DESIGN REPORT
ON
CONSTRUCTION PROJECT
OF
AUTOMOBILE REPAIR & MAINTENANCE WORKSHOP
VOLUME-4

OCTOBER 1978

Japan International Cooperation Agency



1181660 [0]

THE PEOPLE'S REPUBLIC OF BANGLADESH
DETAILED DESIGN REPORT
ON
CONSTRUCTION PROJECT
OF
AUTOMOBILE REPAIR & MAINTENANCE WORKSHOP
VOLUME - 4

OCTOBER 1978

Japan International Cooperation Agency

VOLUME 4
SPECIFICATIONS, QUANTITIES, AND DRAWINGS
OF
TOOLS, MACHINERIES AND SHELVES

C O N T E N T S

	Page
CHAPTER 1. TOOLS MACHINERIES TO BE USED IN PHASE 1	
1-1) Heavy Repair Factory	1
1-1-1) Group Power Line Shop (Brake Shop)	1
LAYOUT	
1-1-2) Group Transmission Shop	17
1-1-3) Group Stall (20 Stalls)	41
1-1-4) Group Front & Rear Axle Shop	89
1-1-5) Group Engine Washing Shop & Engine Disassembling Shop	107
1-1-6) Group Engine Assembling Shop	137
1-1-7) Group Electric Shop	177
1-1-8) Group Pump Shop	207
1-1-9) Group General Machine Shop	219
LAYOUT	
1-2) Parts Storage, Paints/Oil Storage	329
LAYOUT	
1-3) Training Factory	347
1-3-1) Group Engine Course	347
1-3-2) Group Brake & Steering Course	367
1-3-3) Group Electric Course	383
1-3-4) Group Power Line Course	393
1-3-5) Group Training Materials	419
LAYOUT	
1-4) Tire Retreading and Casting/Forging Factory	
1-4-1) Group Tire Retreading	429
1-4-2) Group Casting/Forging	455
1-5) Air Compressor	461
1-6) Car Washer	467

	Page
CHAPTER 2. TOOLS AND MACHINERIES TO BE USED IN PHASE 2	
2-1) Inspection Factory	471
2-1-1) Group Inspection Shop	471
2-1-2) Group Gas Station	495
LAYOUT	
2-2) Periodical Repair Factory	501
LAYOUT	
CHAPTER 3. TOOLS AND MACHINERIES TO BE USED IN PHASE 3	
3-1) Paint and Body Factory	527
3-1-1) Group Wood/Body Shop	527
3-1-2) Group Painting Shop	561
LAYOUT	

CHAPTER 1, TOOL & MACHINERIES TO BE USED IN PHASE 1

1-1) Heavy Repair Factory

1-1-1) Group Power Line Shop (Brake Shop)

Item No.	Qty
1) Air Power Rivetter Capacity:nomal: 2 ton at 5kg/cm ² maximum: 5 ton at 10kg/cm ² Main shaft stroke: 45mm Air pressure required: 5kg/cm ² Type MB-500	1
2) Working Bench Dimension: 1,780(W) x 600(D) x 750(H)mm with two drawers Type T-1000	4
3) Vice Nominal size: 150mm Jaw opening: 155mm Type UV-150	3
4) Brake Shoe Grinder Capacity drum dia.: 380 - 450mm, lining width 250mm Main shaft r.p.m, 4,500 approx. with dust collector and stand Type BSG-250MV	2
5) Hand Truck Load capacity: 300kg Dimension: 900 x 600 x 850mm Type No.101	1

Item No.	Qty
6) Air Drill Capacity: 10mm Revolution: 2,800 r.p.m. Air pressure required: 6kg/cm ² with hose 10mm and PS coupler - nipple Type 211A	3
7) Brake Booster Test Stand Dimension: 700 x 1,200 x 1,600mm Motor: 0.25KW Air supply: 9.9kg/cm ² Indicater: Oil pressure gauge Vacuum gauge Type BTS-10S	1
8) Writing Table Dimension: 1,000(W) x 700(D) x 700(H)mm with seat Type 3616DL/2218ZZ	1
9) Bushing Inserter & Remover Set Case dimension: 205 x 145 x 37mm Push rod: 3 pcs, Attachment: 13 pcs. Type T-130	1
10) Parts Stand Dimension: 620 x 460 x 800mm Interchangeable type Type TS-34	3

Item No.

Qty

11) Air Grinder

3

Wheel dia.: 100mm
Revolution: 11,000 r.p.m.
with PS coupler nipple and hose 5m
Type M-22-S

12) Mechanic Set

6

Consist of: open end wrench
6 x 7, 8 x 9, 10 x 12, 11 x 13, 12 x 14, 14 x 17,
19 x 21mm each 1 pc,
box wrench
8 x 9, 10 x 12, 11 x 13, 12 x 14, 14 x 17,
17 x 19, 19 x 21, 22 x 24mm each 1 pc,
flare nut wrench: 10 x 11, 12 x 14mm each 1 pc.
socket wrench for 9,5mm
8, 9, 10, 11, 12, 13, 14, 17, 19, 21, 22, 23,
24mm each 1 pc,
ratchet handle, nut spinner handle, sliding T
handle, extension bars, universal joint, plug
wrench for 9.5mm, adjustable wrench 250mm,
plier 200, 150mm, nipper 150mm, hammer 450g
- driver 75, 100, 150, 200mm
+ driver 75, 100, 150mm: stubby driver -, +
integral handle driver 280mm, thickness gauge,
plug gap gauge, flat chisel, center punch,
needle file set, point file with case

Type CU-305

1-1-1

Item No. 1

Name Air Power Rivetter

Type MB-500

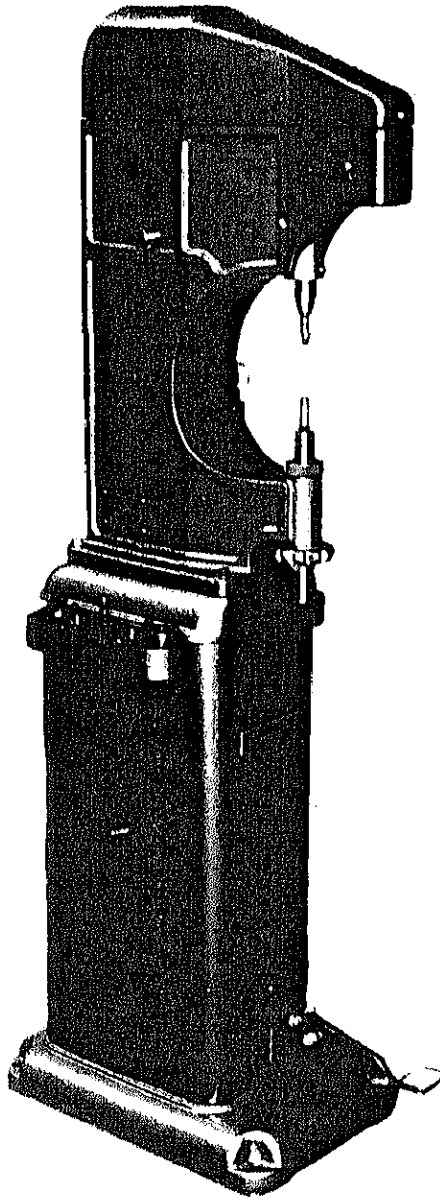

CONSTRUCTION PROJECT OF		DATE
AUTOMOBILE REPAIR & MAINTENANCE WORKSHOP IN BANGLADESH		SCALE
TITLE OF DRAWING		ORG. NO.
		-
JAPAN INTERNATIONAL COOPERATION AGENCY		

--- 1-1-1 ---

Item No. 2

Name Working Bench

Type T-1000



CONSTRUCTION PROJECT		DATE
OF		SCALE
AUTOMOBILE REPAIR & MAINTENANCE WORKSHOP		
IN BANGLADESH		
TITLE OF DRAWING		ORG. NO.
		—
JAPAN INTERNATIONAL COOPERATION AGENCY		

---1-1-1---

Item No. 3

Name Vice

Type UV-150

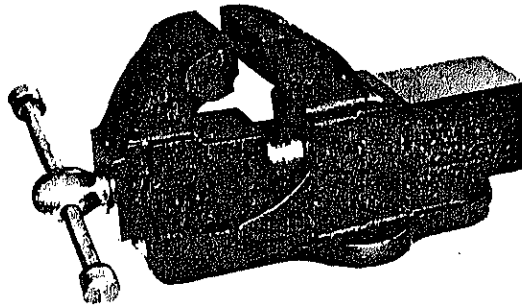

CONSTRUCTION PROJECT OF AUTOMOBILE REPAIR & MAINTENANCE WORKSHOP IN BANGLADESH		DATE
TITLE OF DRAWING		SCALE
		ORG. NO. —
JAPAN INTERNATIONAL COOPERATION AGENCY		

1-1-1

Item No. 4

Name Brake Shoe Grinder

Type BSG-250MV

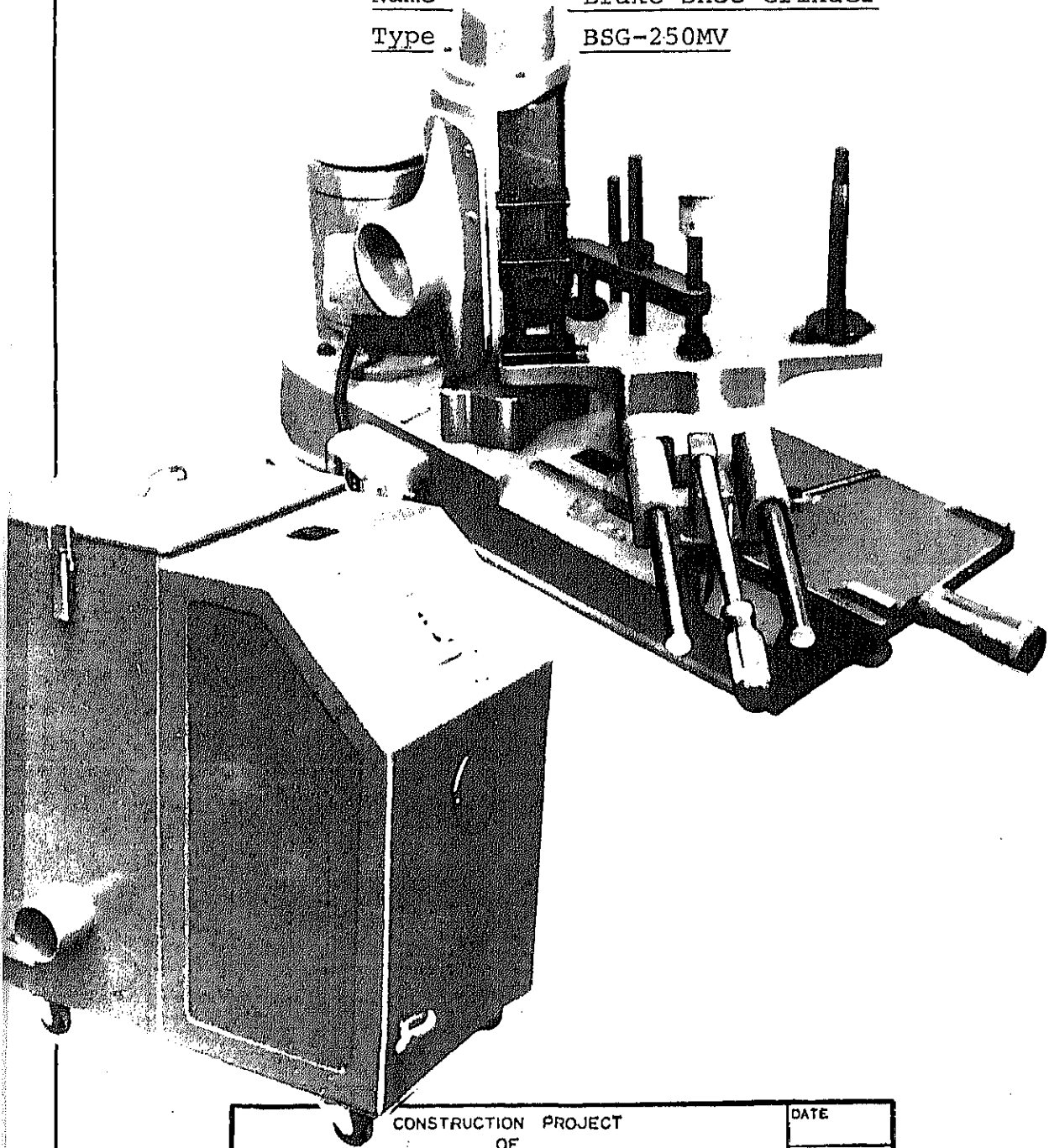

CONSTRUCTION PROJECT OF AUTOMOBILE REPAIR & MAINTENANCE WORKSHOP IN BANGLADESH	DATE
	SCALE
TITLE OF DRAWING	ORG. NO.
JAPAN INTERNATIONAL COOPERATION AGENCY	

1-1-1

Item No. 5

Name Hand Truck

Type No. 101

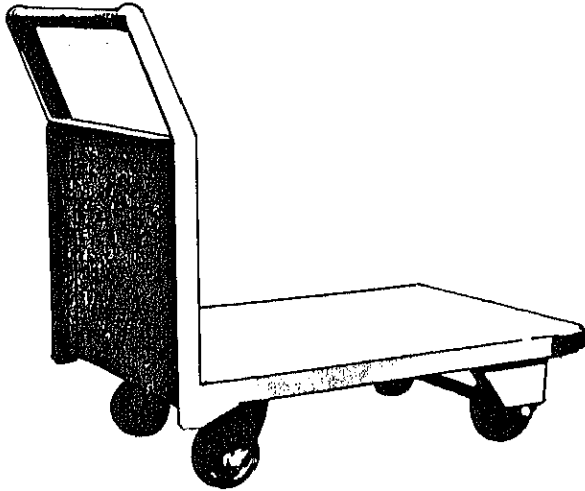

CONSTRUCTION PROJECT OF AUTOMOBILE REPAIR & MAINTENANCE WORKSHOP IN BANGLADESH	DATE
	SCALE
TITLE OF DRAWING	ORG. NO. —
JAPAN INTERNATIONAL COOPERATION AGENCY	

1-1-1

Item No. 6

Name Air Drill

Type 211A

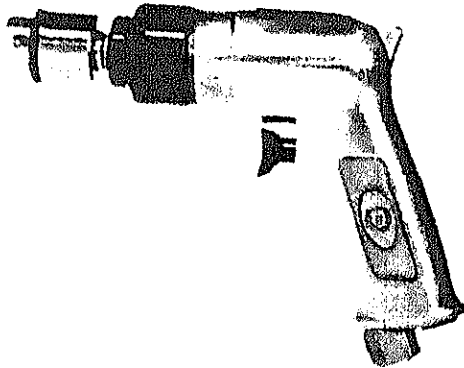

CONSTRUCTION PROJECT OF AUTOMOBILE REPAIR & MAINTENANCE WORKSHOP IN BANGLADESH	DATE
	SCALE
TITLE OF DRAWING	ORG. NO.
JAPAN INTERNATIONAL COOPERATION AGENCY	

1-1-1

Item No. 7

Name Brake Booster Test Stand

Type BTS-10S

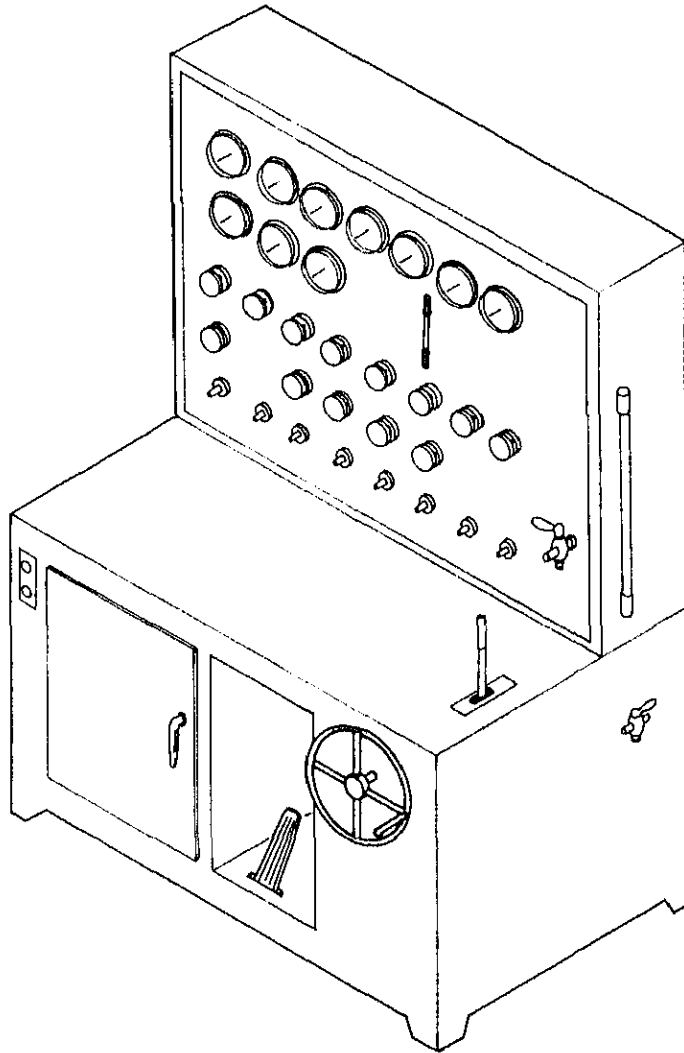

CONSTRUCTION PROJECT OF AUTOMOBILE REPAIR & MAINTENANCE WORKSHOP IN BANGLADESH	DATE
	SCALE
TITLE OF DRAWING	ORG. NO. —
JAPAN INTERNATIONAL COOPERATION AGENCY	

---1-1-1---

Item No. 8

Name Writing Table

Type 3616DL/2218ZZ

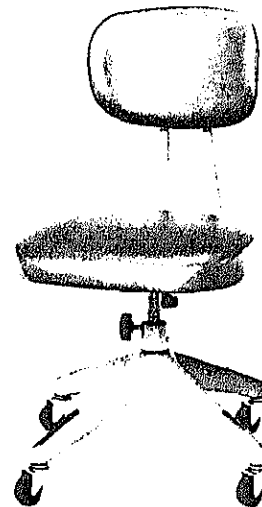
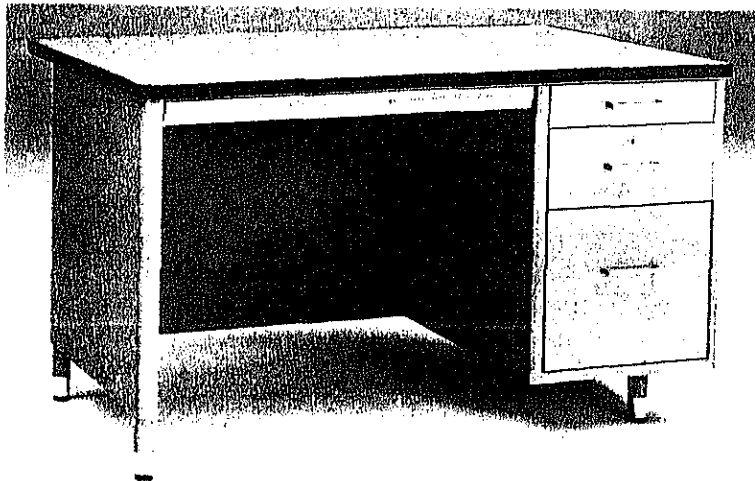

CONSTRUCTION PROJECT OF AUTOMOBILE REPAIR & MAINTENANCE WORKSHOP IN BANGLADESH	DATE
	SCALE
TITLE OF DRAWING	ORG. NO.
	—
JAPAN INTERNATIONAL COOPERATION AGENCY	

1-1-1

Item No. 9

Name Bushing Inserter &
Remover Set

Type T-130

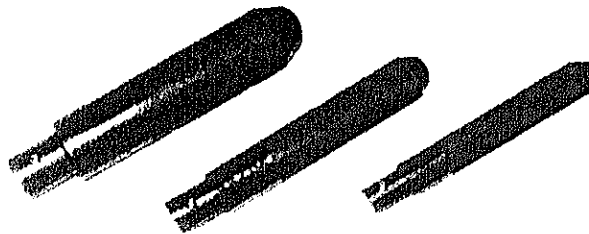
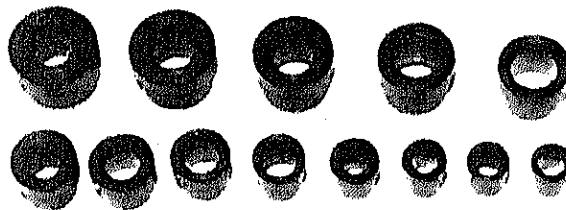
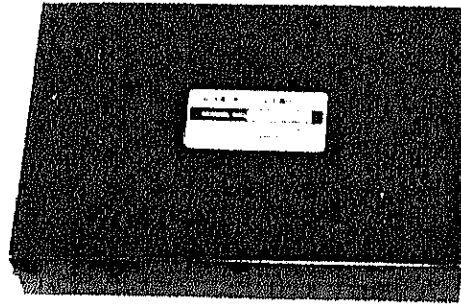

CONSTRUCTION PROJECT OF AUTOMOBILE REPAIR & MAINTENANCE WORKSHOP IN BANGLADESH	DATE
	SCALE
TITLE OF DRAWING	DRG. NO. —
JAPAN INTERNATIONAL COOPERATION AGENCY	

---1-1-1---

Item No. 10

Name Parts Stand

Type TS-34

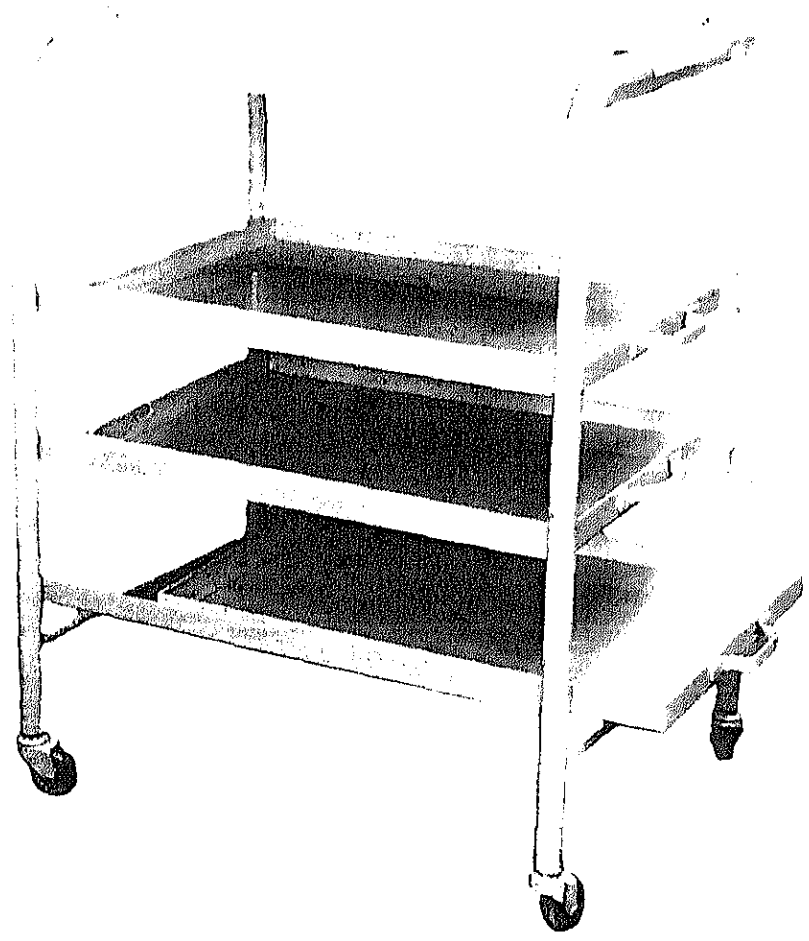

CONSTRUCTION PROJECT OF AUTOMOBILE REPAIR & MAINTENANCE WORKSHOP IN BANGLADESH	DATE
	SCALE
TITLE OF DRAWING	ORG. NO.
JAPAN INTERNATIONAL COOPERATION AGENCY	

---1-1-1---

Item No. 11

Name Air Grinder

Type M-22-S

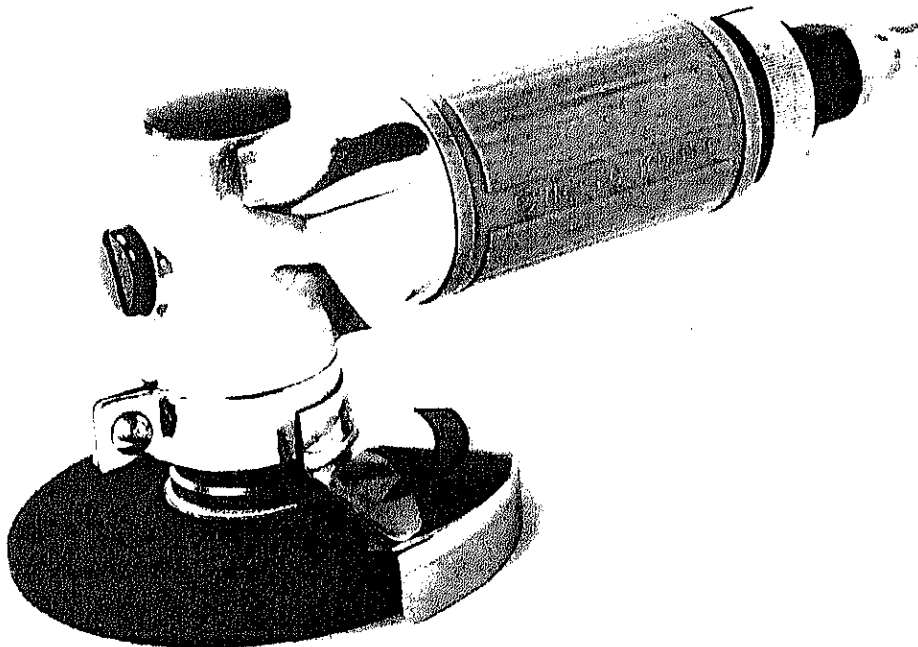

CONSTRUCTION PROJECT OF AUTOMOBILE REPAIR & MAINTENANCE WORKSHOP IN BANGLADESH	DATE
	SCALE
TITLE OF DRAWING	ORG. NO. —
JAPAN INTERNATIONAL COOPERATION AGENCY	

1-1-1

Item No. 12

Name Mechanic Set

Type CU-305

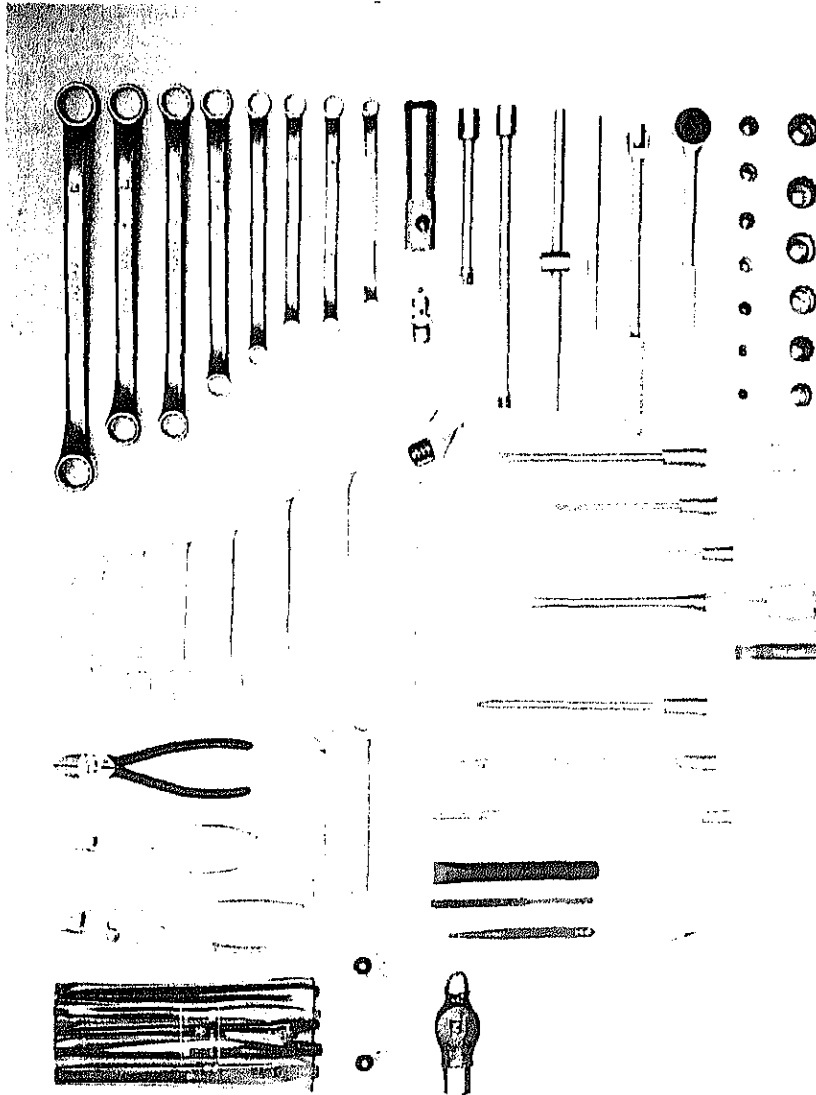

CONSTRUCTION PROJECT OF AUTOMOBILE REPAIR & MAINTENANCE WORKSHOP IN BANGLADESH		DATE
TITLE OF DRAWING		SCALE
		DRG. NO. -
JAPAN INTERNATIONAL COOPERATION AGENCY		

1-1-2) Group Transmission Shop

Item No.

Qty

1) Mission Jack

5

Capacity: 800kg

Saddle height: min. 195mm, max. 785mm

Saddle inclination degree: 26° forward

10° back ward

Saddle sliding, R & L: 30mm

Type HUI-800B

2) Universal Puller Set

2

Consist of 150HD puller set

T-75 wheel puller, T-26, T-28 gear puller

T-20 terminal puller, G-61 slide hammer puller

101S gear puller, each 1 pc. for bus

Type UP-5000

3) Working Bench

4

Dimension: 1,780(W) x 600(D) x 750(H)mm

with two drawers

Type T-1000

Refer to 1-1-1, Item No.12

4) Vice

4

Jaw width: 150mm

Jaw opening: 155mm

Type UV-150

Refer to 1-1-1, Item No,3

5) Parts Washing Stand

1

Motor: 200W

Tank capacity: Oil 55 lit, water 45 lit

Discharge: 14 lit/mon.

with air outlet

Type WS-25

Item No.

Qty

6) Dial Vernier Caliper

Range: 0 - 150mm

Min. Graduation: 0,05mm

Type DNC-15

4

7) Working Lamp

Cord length: 7.7m

Type WL-30

4

8) Mechanic Set

Consist of: open end wrench

6 x 7, 8 x 9, 10 x 12, 11 x 13, 12 x 14, 14 x 17,
19 x 21mm each 1 pc.

box wrench

8 x 9, 10 x 12, 11 x 13, 12 x 14, 14 x 17, 17 x 19
19 x 21, 22 x 24mm each 1 pc.

flare nut wrench: 10 x 11, 12 x 14mm each 1 pc,

socket wrench for 9,5mm

8, 9, 10, 11, 12, 13, 14, 17, 19, 21, 22, 23,
24mm each 1 pc.

ratchet handle, nut spinner handle, sliding T

handle, extension bars, universal joint, plug

wrench for 9.5mm, adjustable wrench 250mm,

plier 200, 150mm, nipper 150mm, hammer 450g,

- driver 75, 100, 150, 200mm

+ driver 75, 100, 150mm: stubby driver -, +

integral handle driver 280mm, thickness gauge,

plug gap gauge, flat chisel, center punch,

needle file set, point file with case

8

Type CN-305

Refer to 1-1-1, Item No.12

Item No.		Qty
9)	Copper Hammer Nominal weight: 650g Type CH-24	4
10)	Soft Hammer Nominal weight: 800g Type SPH-8	4
11)	Snap Ring Plier Range: 10 - 60mm for stem 10 - 55mm for groove Type SPS-4	4
12)	Air Gun Weight: 800g Length: 76 x 80mm with PS coupler - nipple and hose 5m Type ABG-320	4
13)	Writing Table Dimension: 1,000(W) x 700(D) x 700(H)mm with seat Type 3616DL/2218ZZ Refer to 1-1-1, Item No.8	1
14)	Hand Spring Balance Capacity: 2kg, 10kg for check the torque for bearing Type HSB-20	1

(Clutch & Prop-Shaft Shop)

Item No.	Qty
15) Air Power Rivetter Capacity normal: 2 ton at 5kg/cm ² maximum: 5 ton at 10kg/cm ² Main shaft stroke: 45mm Air pressure required: 5kg/cm ² Type MB-500 Refer to 1-1-1, Item No.1	1
16) Hydraulic Press Capacity: 15 ton Ram stroke: 140mm Auxiliary screw-stroke: 120mm Distance between frames: 675mm Distance between tables: 185mm Vertical travel tables: 630mm Type HP-30C	1
17) Working Table Size: 1,780(W) x 600(D) x 750(H)mm with two drawers UV-150, Vice are equipped Type T-1000 Refer to 1-1-1, Item No,2	2
18) Vice Jaw Width: 150mm Jaw opening: 155mm Type UV-150 Refer to 1-1-1, Item No,3	2

Item No.	Qty
19) Drilling Machine Capacity: 23mm Motor: 400W 3 phase Swing: 450mm Distance from spindle to table: 430mm Distance from spindle to bed: 660mm Spindle taper: No,2 Main spindle revolution: 165, 200, 415, 675, 1090, 1750 r.p.m. Automatic feed: 0.08, 0.14, 0.2 with stand with drill 1.0 - 23.0mm by 0.5mm Type ESD-460AF	1
20) Working Bench Dimension: 1,780(W) x 600(D) x 750(H)mm with two drawers Type T-1000 Refer to 1-1-2, Item No.5	1
21) Working Table Dimension: 1,000(W) x 700(D) x 700(H)mm with seat Type 3616DL/2218ZZ Refer to 1-1-1, Item No.8	1
22) Parts Washing Stand Tank capacity: 55 lit -- oil 45 lit -- water Discharge: 14 lit/min. Motor: 200W 1 - phase Type WS-25 Refer to 1-1-2, Item No.5	1

Item No.

Qty

13) Hand Truck

1

Load: 300kg

Dimension: 900 x 600 x 850mm

Type No.101

Refer to 1-1-1, Item No.5

14) Mechanic Set

4

Consist of: open end wrench

6 x 7, 8 x 9, 10 x 12, 11 x 13, 12 x 14, 14 x 17,
19 x 21mm each 1 pc.

box wrench

8 x 9, 10 x 12, 11 x 13, 12 x 14, 14 x 17,
17 x 19, 19 x 21, 22 x 24mm each 1 pc.

flare nut wrench: 10 x 11, 12 x 14mm each 1 pc.

socket wrench for 9.5mm

8, 9, 10, 11, 12, 14, 17, 18, 19, 21, 22 23,
24mm each 1 pc.

ratchet handle, nut spinner handle sliding T
handle, extension bars, universal joint, plug
wrench for 9.5mm, adjustable wrench 250mm, plier
200, 150mm, nipper 150mm, hammer 450g.

- driver 75, 100, 150, 200mm

+ driver 75, 100, 150mm: stubby driver -, +
integral handle driver 280mm, thickness gauge,
plug gap gauge, flat chisel, center punch, needle
file set, point file with case

Type CU-305

Refer to 1-1-1, Item No.12

15) Snap Ring Plier Set

2

Range: 10 - 60mm for stem

10 - 55mm for groove

Type SPS-4

Refer to 1-1-2, Item No.11

Item No.	Qty
26) Bushing Inserter & Remover Set Consist of attachment: 18 - 40mm 13 pcs. push rod: 3 pcs. Type T-130 Refer to 1-1-1, Item No.9	1
27) Chisel & Punch Set Consist of 20 pcs. tools Type 320	1
28) Clutch Aligner Case size: 255 x 80 x 55mm Type HC-15	2
29) Air Gun Set Weight: 0,8kg, Length: 76 x 80mm with PS coupler - nipple and hose 5m Type ABG-320 Refer to 1-1-2, Item No,12	2
30) Spring Tester Capacity: 0 - 240kg Type 240B	1
31) Clutch Rebuilder Floor type Hydraulic Outer dia of pressure plate Coner: 500mm Inner dia of disc spline: 16mm Plate diameter: 700mm Type CRA-500	2

_ _ 1-1-2 _ _

Item No.	1
Name	Mission Jack
Type	HUJ-800B

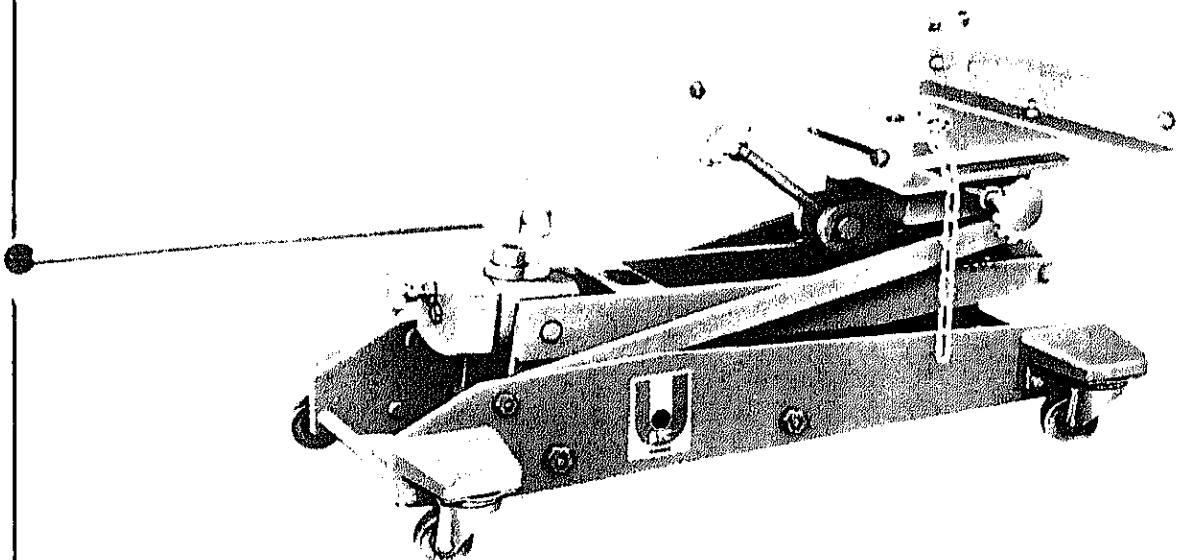

CONSTRUCTION PROJECT OF AUTOMOBILE REPAIR & MAINTENANCE WORKSHOP IN BANGLADESH	DATE
	SCALE
TITLE OF DRAWING	ORG. NO.
	—
JAPAN INTERNATIONAL COOPERATION AGENCY	

1-1-2

Item No. 2

Name Universal Puller Set

Type UP-5000

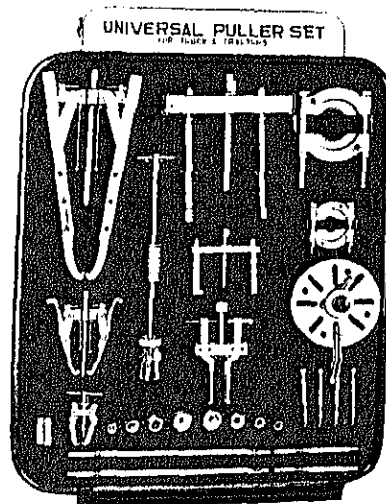

CONSTRUCTION PROJECT OF		DATE
AUTOMOBILE REPAIR & MAINTENANCE WORKSHOP IN BANGLADESH		SCALE
TITLE OF DRAWING		DRG. NO. —
JAPAN INTERNATIONAL COOPERATION AGENCY		

1-1-2

Item No. 5

Name Parts Washing Stand

Type WS-25

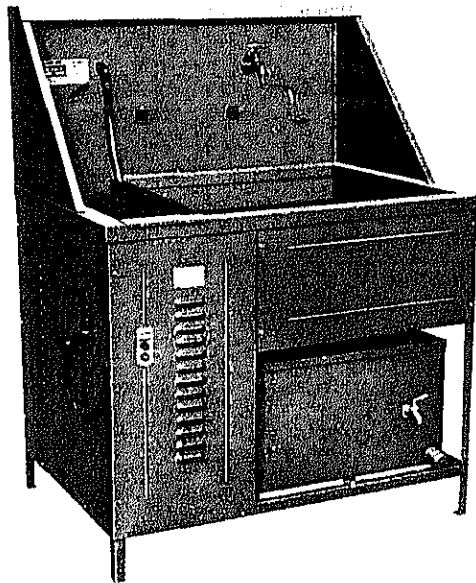

CONSTRUCTION PROJECT OF AUTOMOBILE REPAIR & MAINTENANCE WORKSHOP IN BANGLADESH	DATE
	SCALE
TITLE OF DRAWING	DRG. NO. —
JAPAN INTERNATIONAL COOPERATION AGENCY	

1-1-2

Item No. 6

Name Dial Vernier Caliper

Type DNC-15

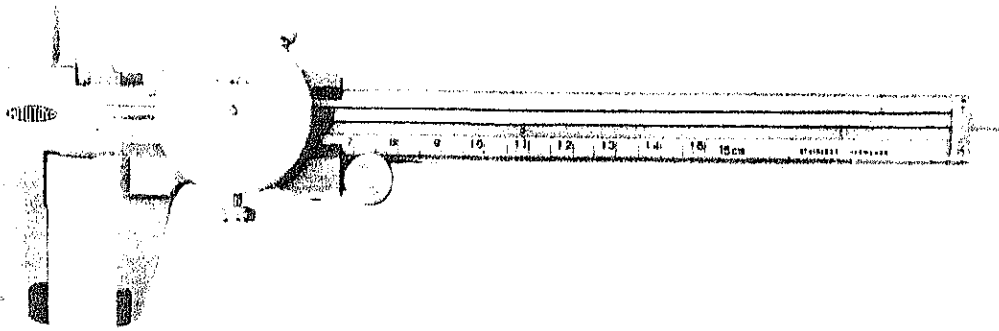

CONSTRUCTION PROJECT OF AUTOMOBILE REPAIR & MAINTENANCE WORKSHOP IN BANGLADESH	DATE
	SCALE
TITLE OF DRAWING	ORG. NO. —
JAPAN INTERNATIONAL COOPERATION AGENCY	

--- 1-1-2 ---

Item No. 7

Name Working Lamp

Type WL-30

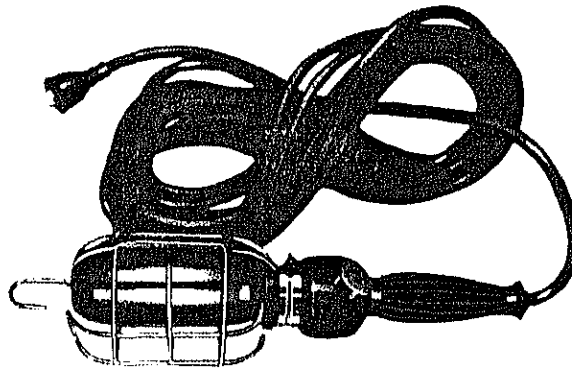

CONSTRUCTION PROJECT OF		DATE
AUTOMOBILE REPAIR & MAINTENANCE WORKSHOP IN BANGLADESH		SCALE
TITLE OF DRAWING		DRG. NO. —
JAPAN INTERNATIONAL COOPERATION AGENCY		

1-1-2

Item No. 9

Name Copper Hammer

Type CH-24



CONSTRUCTION PROJECT OF	DATE
AUTOMOBILE REPAIR & MAINTENANCE WORKSHOP IN BANGLADESH	SCALE
TITLE OF DRAWING	ORG. NO. —
JAPAN INTERNATIONAL COOPERATION AGENCY	

---1-1-2---

Item No. 10

Name Soft Hammer

Type SPH-8

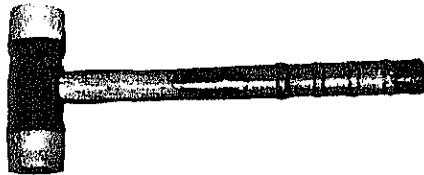

CONSTRUCTION PROJECT OF AUTOMOBILE REPAIR & MAINTENANCE WORKSHOP IN BANGLADESH	DATE
	SCALE
TITLE OF DRAWING	ORG. NO. —
JAPAN INTERNATIONAL COOPERATION AGENCY	

1-1-2

Item No. 11

Name Snap Ring Plier

Type SPS-4

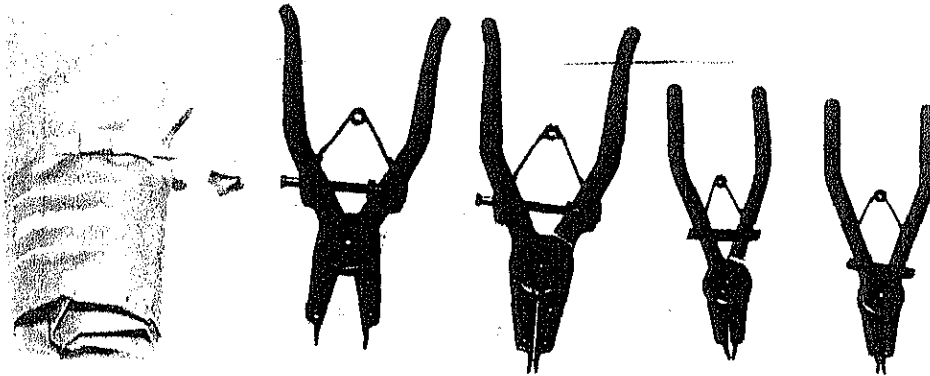

CONSTRUCTION PROJECT OF	DATE
AUTOMOBILE REPAIR & MAINTENANCE WORKSHOP IN BANGLADESH	SCALE
TITLE OF DRAWING	DRG. NO. —
JAPAN INTERNATIONAL COOPERATION AGENCY	

_ _ 1-1-2 _ _

Item No.	12
Name	Air Gun
Type	ABG-320

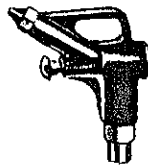

CONSTRUCTION PROJECT OF AUTOMOBILE REPAIR & MAINTENANCE WORKSHOP IN BANGLADESH	DATE
	SCALE
TITLE OF DRAWING	ORG. NO. —
JAPAN INTERNATIONAL COOPERATION AGENCY	

---1-1-2---

Item No. 14

Name Hand Spring Balance

Type HSB-20



CONSTRUCTION PROJECT OF AUTOMOBILE REPAIR & MAINTENANCE WORKSHOP IN BANGLADESH	DATE
	SCALE
TITLE OF DRAWING	DRG. NO. —
JAPAN INTERNATIONAL COOPERATION AGENCY	

1-1-2

Item No. 16

Name Hydraulic Press

Type HP-30C

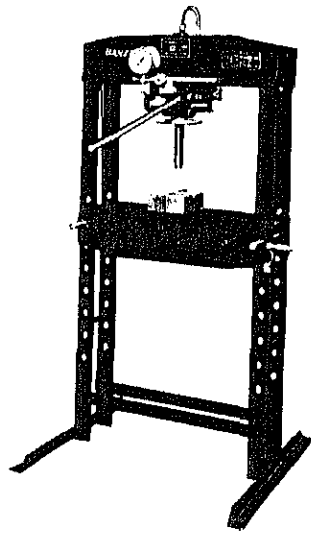

CONSTRUCTION PROJECT OF AUTOMOBILE REPAIR & MAINTENANCE WORKSHOP IN BANGLADESH	DATE
	SCALE
TITLE OF DRAWING	ORG. NO. -
JAPAN INTERNATIONAL COOPERATION AGENCY	

1-1-2

Item No. 19

Name Drilling Machine

Type ESD-460AF

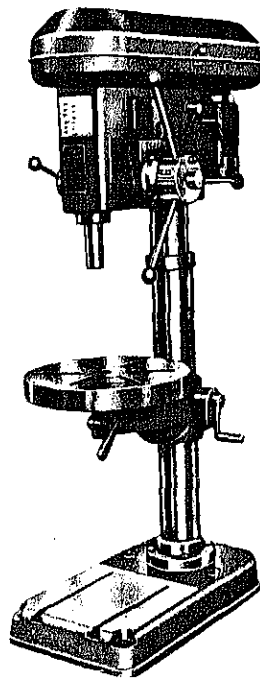

CONSTRUCTION PROJECT OF AUTOMOBILE REPAIR & MAINTENANCE WORKSHOP IN BANGLADESH	DATE
	SCALE
TITLE OF DRAWING	DRG. NO. —
JAPAN INTERNATIONAL COOPERATION AGENCY	

1-1-2

Item No. 27

Name Chisel & Punch Set

Type 320

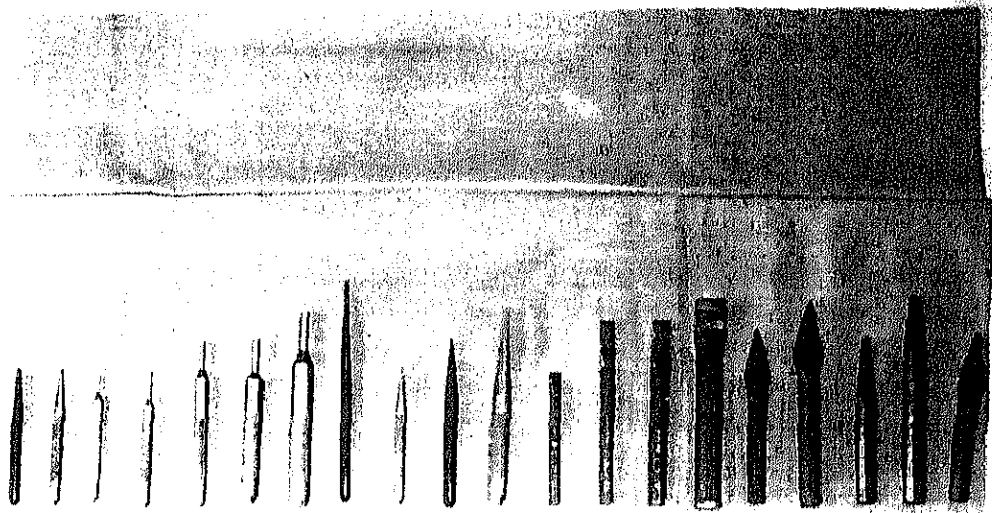

CONSTRUCTION PROJECT OF		DATE
AUTOMOBILE REPAIR & MAINTENANCE WORKSHOP IN BANGLADESH		SCALE
TITLE OF DRAWING		ORG. NO. —
JAPAN INTERNATIONAL COOPERATION AGENCY		

1-1-2

Item No. 28

Name Clutch Aligner

Type HC-15

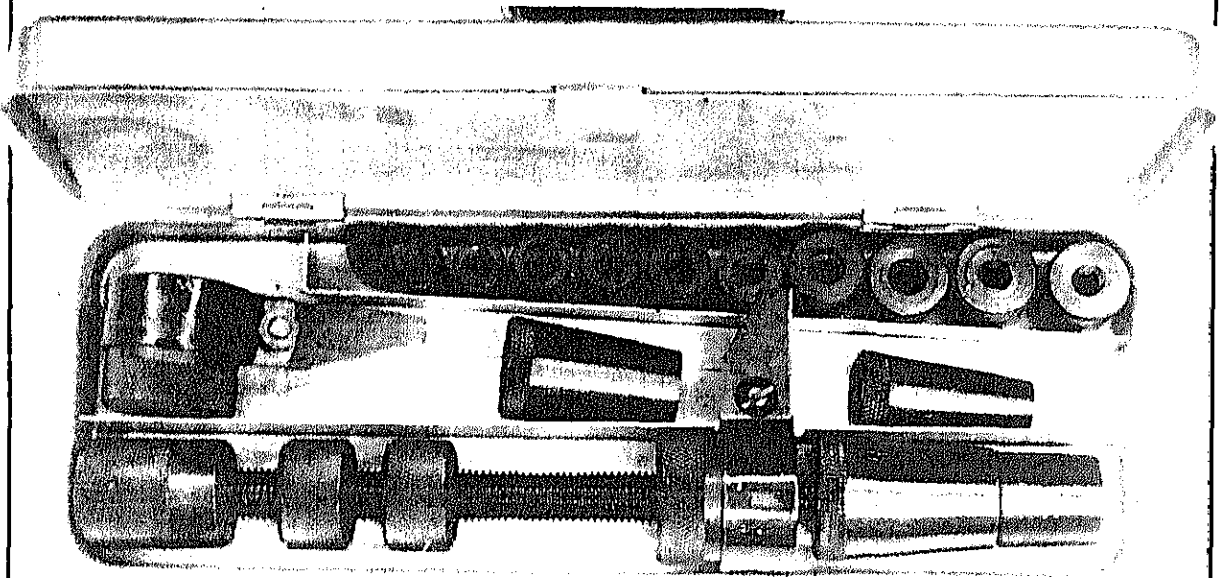

CONSTRUCTION PROJECT OF AUTOMOBILE REPAIR & MAINTENANCE WORKSHOP IN BANGLADESH	DATE
	SCALE
TITLE OF DRAWING	ORG. NO. —
JAPAN INTERNATIONAL COOPERATION AGENCY	

---1-1-2---

Item No. 30

Name Spring Tester

Type 240B

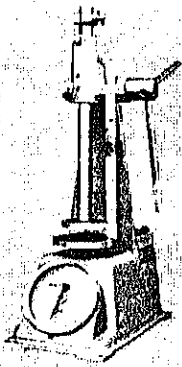

CONSTRUCTION PROJECT OF AUTOMOBILE REPAIR & MAINTENANCE WORKSHOP IN BANGLADESH	DATE
	SCALE
TITLE OF DRAWING	ORG. NO. —
JAPAN INTERNATIONAL COOPERATION AGENCY	

---1-1-2---

Item No. 31

Name Clutch Rebuilder

Type CRA-500

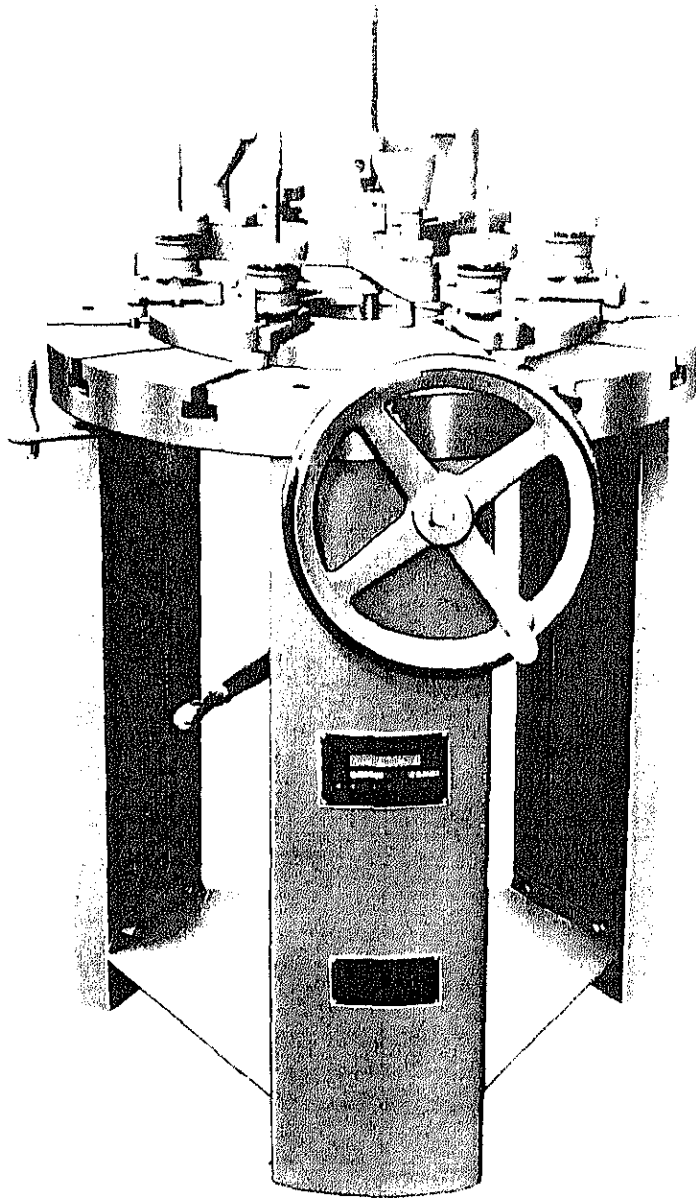

CONSTRUCTION PROJECT OF		DATE
AUTOMOBILE REPAIR & MAINTENANCE WORKSHOP IN BANGLADESH		SCALE
TITLE OF DRAWING		DRG. NO.
		—
JAPAN INTERNATIONAL COOPERATION AGENCY		

1-1-3) Group Stall (20 Stalls)

Item No.	Qty
1) Hydraulic Garage Jack Capacity: 10 ton Saddle height: 160 - 560mm Type M-1000M	10
2) Hydraulic Garage Jack Capacity: 5 ton Saddle height: 150 - 560mm Type M-500M	10
3) Rigid Rack Capacity: 2.5 + 2.5 ton Saddle height: 460 - 760mm Type M-15LB	80
4) Wheel Dolly Capacity: 500kg Arm lift: 60 - 210mm Type WD-1100	10
5) Hydraulic Floor Crane Capacity: 1 ton Air length: 1,200mm - 1 ton : 1,350mm - 750kg : 1,550mm - 200kg Type OC-H1000	5
6) Transmission Jack Capacity: 800kg Saddle height: 195 - 785mm Saddle inclination: 26° forward 10° backward	10

Item No.

Qty

Saddle sliding, right & left: 30mm

Type HUI-800B

Refer to 1-1-2, Item No.1

7) Air Lift

10

Capacity: 3,500kg

Fork height: 140 - 1,190mm

Air pressure required: 10kg/cm² over

Type AL-400A

8) Arc Welder

4

Rated current: 500A

Current adjustable: 505 - 90A

Electrode: 8 - 3.2mm

Primary input: 40KVA

Power: 200V or more, 1 - phase with accessories

Type AT-SS-500

9) Gas Welder Set

4

Consist of oxy. and acetylene

Regulator, gas welding torch, gas cutting torch, hoses,
cylinder truck, etc.

Type B/GS-10

10) Air Disc Grinder

4

Wheel size: 180mm

Revolution: 7,000 r.p.m.

Air pressure required: 6kg/cm²

Type M-70S

Item No.		Qty
11)	Hand Truck Load: 300kg Dimension: 900 x 600 x 850mm Type No.101 Refer to 1-1-1, Item No.5	10
12)	Service Creeper Dimension: 490 x 920mm Type SC-5B	40
13)	Universal Puller Set Consist of 150HD puller set, T-75 wheel puller, T-26, T-28 gear puller, T-20 terminal puller, G-61 slide hammer puller, 101S gear puller each 1 pc. for bus Type UP-5000 Refer to 1-1-2, Item No.2	4
14)	Pilot Bearing Puller Capacity: 12 ϕ , 15 ϕ mm Type PB-100	20
15)	Slide Hammer Puller Jaw opening: 100mm - outside 85mm - inside Type G-60	20
16)	Tube Flaring & Cutting Tool Pipe cutting capacity: 3 - 28mm Pipe flaring capacity: 6, 8, 10, 13, 16mm Type TF-200W	4
17)	Universal Wheel Hub Puller Type T-75 for bus	20

Item No.	Qty
<p>18) Drum Greaser</p> <p>Grease lub pump mounted on dolly, equipped with lubrication hose and high pressure gun (850 - 204) pump with follow plate are fixed in drum cover,</p> <p>Lub pump (DR-110A 45)</p> <p>Pnumatic type with air regulator</p> <p>Pump ratio: 45 : 1</p> <p>Cylinder dia.: 110ϕ mm</p> <p>Air pressure required: max, 7kg/cm²</p> <p>Type DL-142</p>	5
<p>19) Universal Jack</p> <p>Capacity: 500kg</p> <p>Saddle height: 100 - 630mm</p> <p>Saddle tilting: 150 forward and backward</p> <p>Type UJ-500</p>	10
<p>20) Socket Wrench Set</p> <p>Socket: 21 - 63mm 16 pcs.</p> <p>Square drive: 19mm</p> <p>with extension bars and handles</p> <p>Type HD-290M</p>	10
<p>21) Diff. Jack</p> <p>Capacity: 500kg</p> <p>Saddle height: 140 - 600mm</p> <p>Type DJ-50</p>	20
<p>22) Gasket Cutting Punch Set</p> <p>Size: 5, 6, 8, 9, 10, 11, 12, 14, 16mm</p> <p>Type H-75</p>	10

Item No.		Qty
23)	Transmission Jack Capacity: 800kg Saddle height: 195 - 785mm Saddle inclination: 26° forward 10° backward Saddle sliding, right & left: 30mm Type HUI-800B Refer to 1-1-2, Item No.1	20
24)	Air Chisel Set Blow: 3,000/min. with chisel assortment set Type D-210	10
25)	Auto Lub Set Oil lub pump mounted on dolly equipped with suction hose dispensing hose and grip meter (E-18, 230) 1 - 10 lit. Pump (KP-110): pneumatic type with air regulator cylinder dia.: 110 ϕ mm capacity: 5.5 lit/min. Air pressure required: max, 7kg/cm ² Type AL-205	8
26)	Pipe Wrench Range: 6 - 13mm Type PW-6	10
27)	Pipe Wrench Range: 13 - 18mm Type PW-14	10
28)	Pipe Wrench Range: 50 - 95mm Type PW-36	10

Item No.	Qty
29) Working Lamp Cord length: 7,7m Type WL-30 Refer to 1-1-2, Item No,7	20
30) Air Meter Pressure range: 0.2 - 10kg/cm ² Indicator panel size: 364 x 244mm with hose 10m and air chuck stand type Type AT-300	4
31) U Bolt Wrench Size: 22 - 32mm Type UB-2224/2632	20
32) Air Impact Wrench Bolt capacity: 40mm Square drive: 25,4mm Air pressure required: 6kg/cm ² with sockets for Mitsubishi and Isuzu Type AW-4000T	10
33) Air Impact Wrench Bolt capacity: 20mm Square drive: 19mm Air pressure required: 6kg/cm ² with sockets for Mitsubishi and Isuzu Type AW-2000T	10
34) Air Impact Wrench Bolt capacity: 16mm Square drive: 12,7mm Air pressure required: 6kg/cm ² with sockets for Mitsubishi and Isuzu Type AW-1600T	10

Item No.		Qty
35)	<p>Work Bench</p> <p>Dimension: 1,780(L) x 600(W) x 750(H)mm</p> <p>with two drawers</p> <p>Type T-1000</p> <p>Refer to 1-1-1, Item No.2</p>	10
36)	<p>Vice</p> <p>Jaw width: 150mm</p> <p>Jaw opening: 155mm</p> <p>Type UV-150</p> <p>Refer to 1-1-1, Item No.3</p>	10
37)	<p>Fork Lift</p> <p>Capacity: 1 ton</p> <p>Gasoline engine</p> <p>Type FG-10</p>	3
38)	<p>Tool Stand</p> <p>Dimension: 620 x 460 x 800mm</p> <p>Interchangeable tray, 4 - steps</p> <p>Type TS-34</p> <p>Refer to 1-1-1, Item No.10</p>	40
39)	<p>Drain Cart</p> <p>Drain capacity: 70 lit</p> <p>Transformer pump: pneumatic type</p> <p>cylinder dia.: 65ϕ mm, capacity: 7 - 8 lit/min.</p> <p>Air pressure required: max, 7kg/cm²</p> <p>Size: 960 x 530 x 160mm</p> <p>Type DC-77</p>	20

Item No.	Qty
10) Electric Pencil Power: 1 - phase Type EP-A	1
11) Impact Driver With (-) bit and (+) bit each 3 pcs. Type #2600	20
12) Writing Table Dimension: 1,000(W) x 700(D) x 700(H)mm with seat Type 3616DL/2218ZZ Refer to 1-1-1, Item No.8	10
13) Snap Ring Plier Range: 10 - 60mm for stem 10 - 55mm for groove Type SPS-4 Refer to 1-1-2, Item No.11	10
14) Mechanic Tool Set Consist of: open end wrench 6 x 7, 8 x 9, 10 x 12, 14 x 17, 19 x 21mm each 1 pc. box wrench 8 x 9, 10 x 12, 11 x 13, 12 x 14, 14 x 17, 17 x 19, 19 x 21, 22 x 24mm each 1 pc, flare nut wrench: 10 x 11, 12 x 14mm each 1 pc. socket wrench for 9.5mm 8, 9, 10, 11, 12, 13, 14, 17, 19, 21, 22, 23, 24mm each 1 pc. ratchet handle, nut spinner handle, sliding T handle, extension bars, universal joint,	100

Item No.

Qty

plug wrench for 9.5mm, adjustable wrench 250mm,
plier 200, 150mm, nipper 150mm, hammer 450g,
- driver 75, 100, 150, 200mm
+ driver 75, 100, 150mm: stubby driver -, +
integral handle driver 280mm, thickness gauge,
plug gap gauge, flat chisel, center punch,
needle file set, point file with case

Type CU-305

Refer to 1-1-1, Item No.12

45) Circuit Tester

DC: 0 - 2.5/5/10/25/50V

0 - 250mA, 0 - 20A

AC: 0 - 10/50/250/1000V

Type TH-20

10

46) Tool Cabinet Set

Consist of:

No.26	Thickness gauge
BAG-32C	Brake adjusting gauge
No.22M	Spark plug gap gauge
315	Screw pitch gauge
SR-LB	Stainless holding rule
BSC-20	Vernier caliper
No.30M	Socket wrench set without case long socket, 14, 17, 19, 21, 23, 26 29mm
BT-42	Offset box wrench set
BT-41	- do -
BT-62	- do -
BT-52	- do -
UB-2326	U bolt nut wrench
UBI-3034	- do -

Item No.

Qty

T-20	Terminal gear puller
T-24	Gear puller
T-26	- do -
80H	High tension test driver
250	Stubby driver
GF	Tire gauge
V-12	Hacksaw frame engineers file: flat 200/300mm round 200mm with handle
PW-14	Pipe wrench
BH-24	Ball plain hammer
TH-2	Test hammer
PH-2	Plastic hammer
	ratcheting spanner: 10, 12, 14, 17, 19, 21mm
E-10	Extension bar
TH-11	T handle
UJ-4	Universal joint
L-120M	Socket wrench set without case offset box wrench set (BT-9/BT-6A/BT-5/BT-1)
T-106M	Tappet wrench set
T-32HMF	Wheel nut wrench
T-32E	Wheel nut wrench
T-126M	Cross rim wrench plastic screw driver: 50, 75, 100, 125, 150mm plastic cross driver: #1, 2, 3, 4
H-26	Combination plier
H-28	- do -
L-26	Thin straight nose plier
M-26	Long nose plier

Item No.

Qty

J-26 Thin bent nose plier

MG-210 Water pump wrench plier

CT-7 Cutting plier

adjustable wrench (BS-6/8/10)

Cabinet dimension: 1,020 x 440 x 1,210mm

Type D-3000

1-1-3

Item No. 1

Name Hydraulic Garage Jack

Type M-1000M

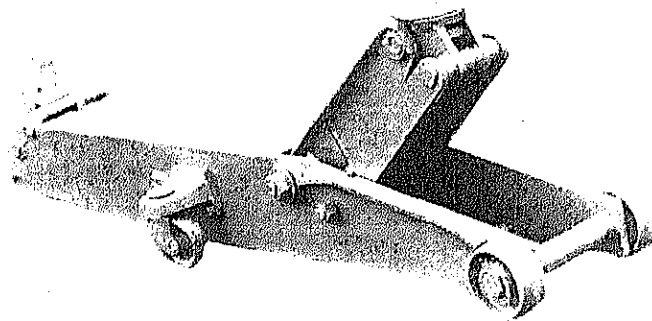

CONSTRUCTION PROJECT OF AUTOMOBILE REPAIR & MAINTENANCE WORKSHOP IN BANGLADESH	DATE
	SCALE
TITLE OF DRAWING	DRG. NO. —
JAPAN INTERNATIONAL COOPERATION AGENCY	

1-1-3

Item No. 2

Name Hydraulic Garage Jack

Type M-500M

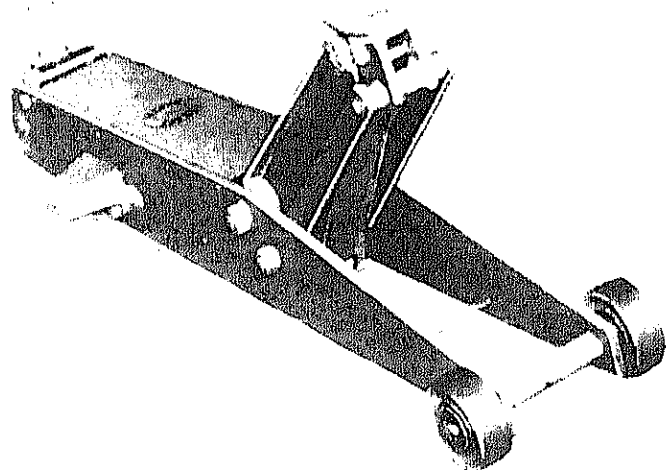
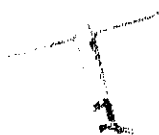

CONSTRUCTION PROJECT OF AUTOMOBILE REPAIR & MAINTENANCE WORKSHOP IN BANGLADESH	DATE
	SCALE
TITLE OF DRAWING	DRG. NO. —
JAPAN INTERNATIONAL COOPERATION AGENCY	

1-1-3

Item No. 3

Name Rigid Rack

Type M-15LB

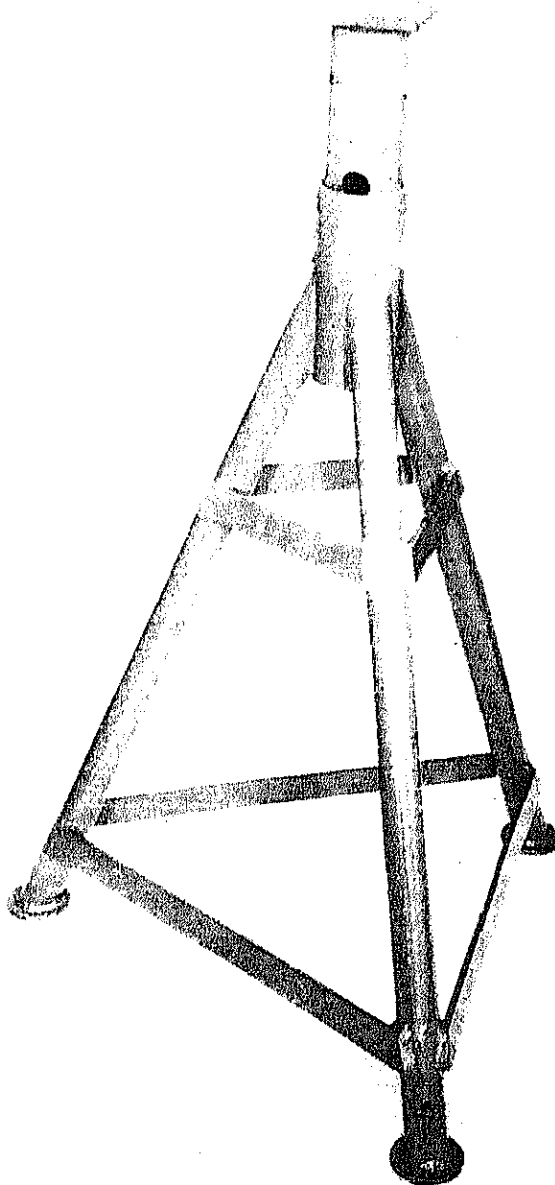

CONSTRUCTION PROJECT OF AUTOMOBILE REPAIR & MAINTENANCE WORKSHOP IN BANGLADESH	DATE
	SCALE
TITLE OF DRAWING	DRG. NO. —
JAPAN INTERNATIONAL COOPERATION AGENCY	

1-1-3

Item No. 4

Name Wheel Dolly

Type WD-1100

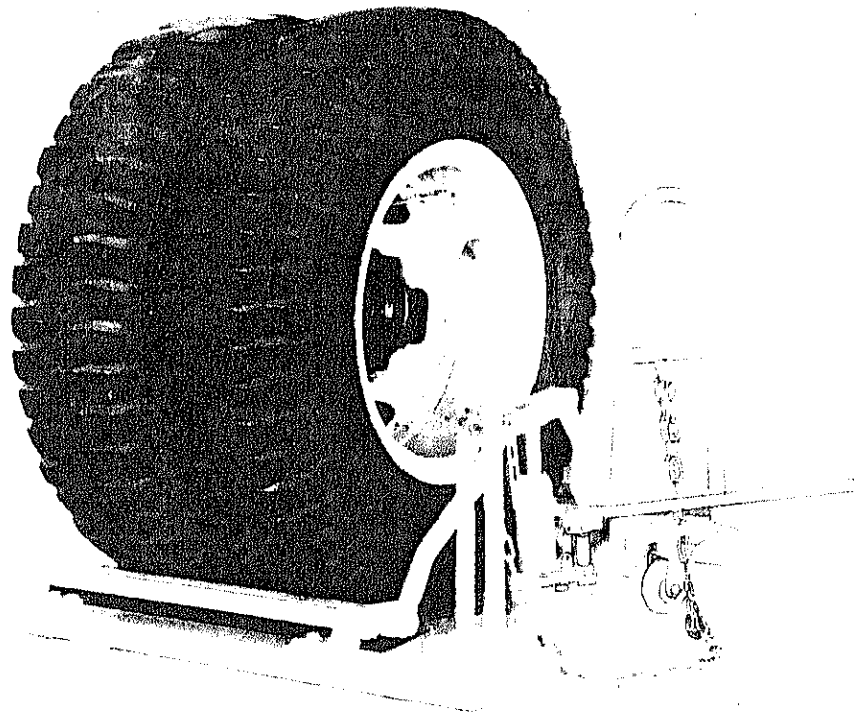

CONSTRUCTION PROJECT OF		DATE
AUTOMOBILE REPAIR & MAINTENANCE WORKSHOP IN BANGLADESH		SCALE
TITLE OF DRAWING		ORG. NO.
		—
JAPAN INTERNATIONAL COOPERATION AGENCY		

1-1-3

Item No. 5

Name Hydraulic Flour Crane

Type OC-H1000

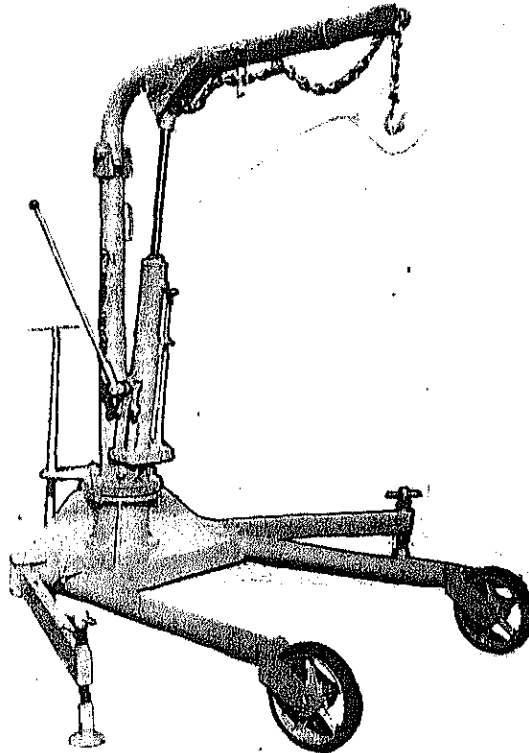

CONSTRUCTION PROJECT OF AUTOMOBILE REPAIR & MAINTENANCE WORKSHOP IN BANGLADESH	DATE
	SCALE
TITLE OF DRAWING	ORG. NO. —
JAPAN INTERNATIONAL COOPERATION AGENCY	

1-1-3

Item No. 7

Name Air Lift

Type AL-400A

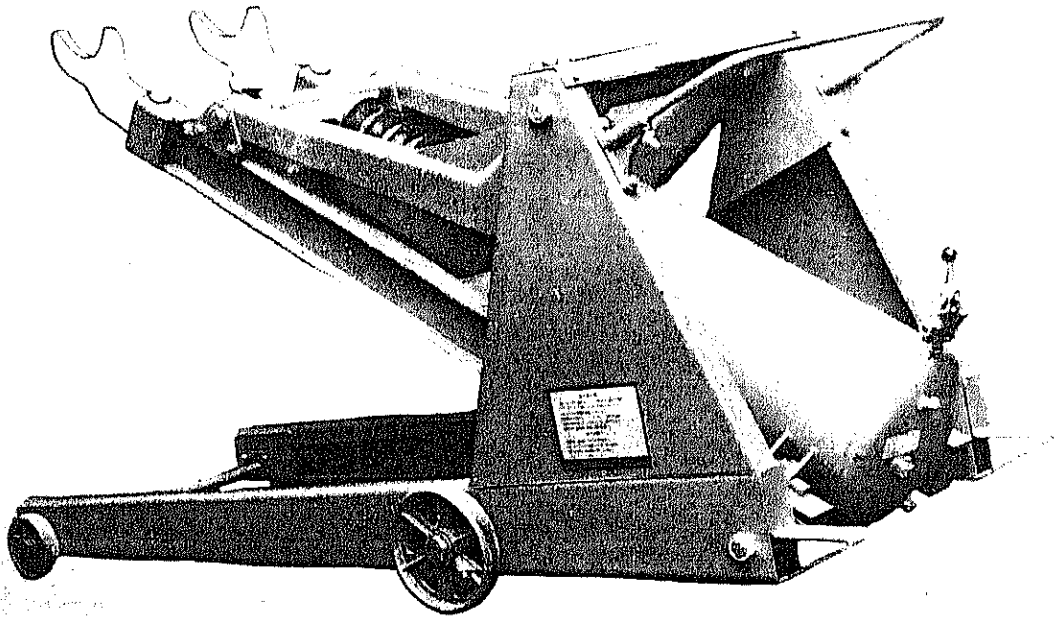

CONSTRUCTION PROJECT		DATE
OF		SCALE
AUTOMOBILE REPAIR & MAINTENANCE WORKSHOP		ORG. NO.
IN BANGLADESH		—
TITLE OF DRAWING		
JAPAN INTERNATIONAL COOPERATION AGENCY		

1-1-3

Item No. 8

Name Arc Welder

Type AT-SS-500

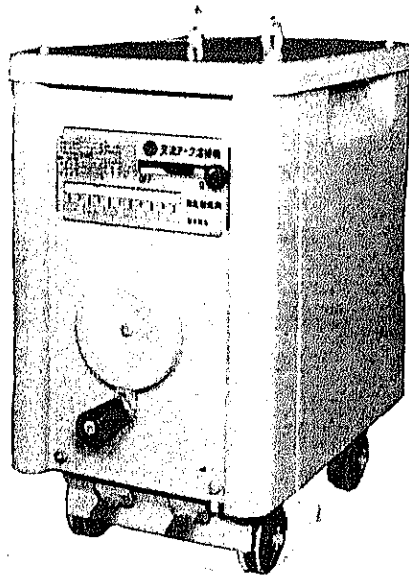

CONSTRUCTION PROJECT OF AUTOMOBILE REPAIR & MAINTENANCE WORKSHOP IN BANGLADESH	DATE
	SCALE
TITLE OF DRAWING	ORG. NO. —
JAPAN INTERNATIONAL COOPERATION AGENCY	

1-1-3

Item No. 9

Name Gas Welder Set

Type B/GS-10

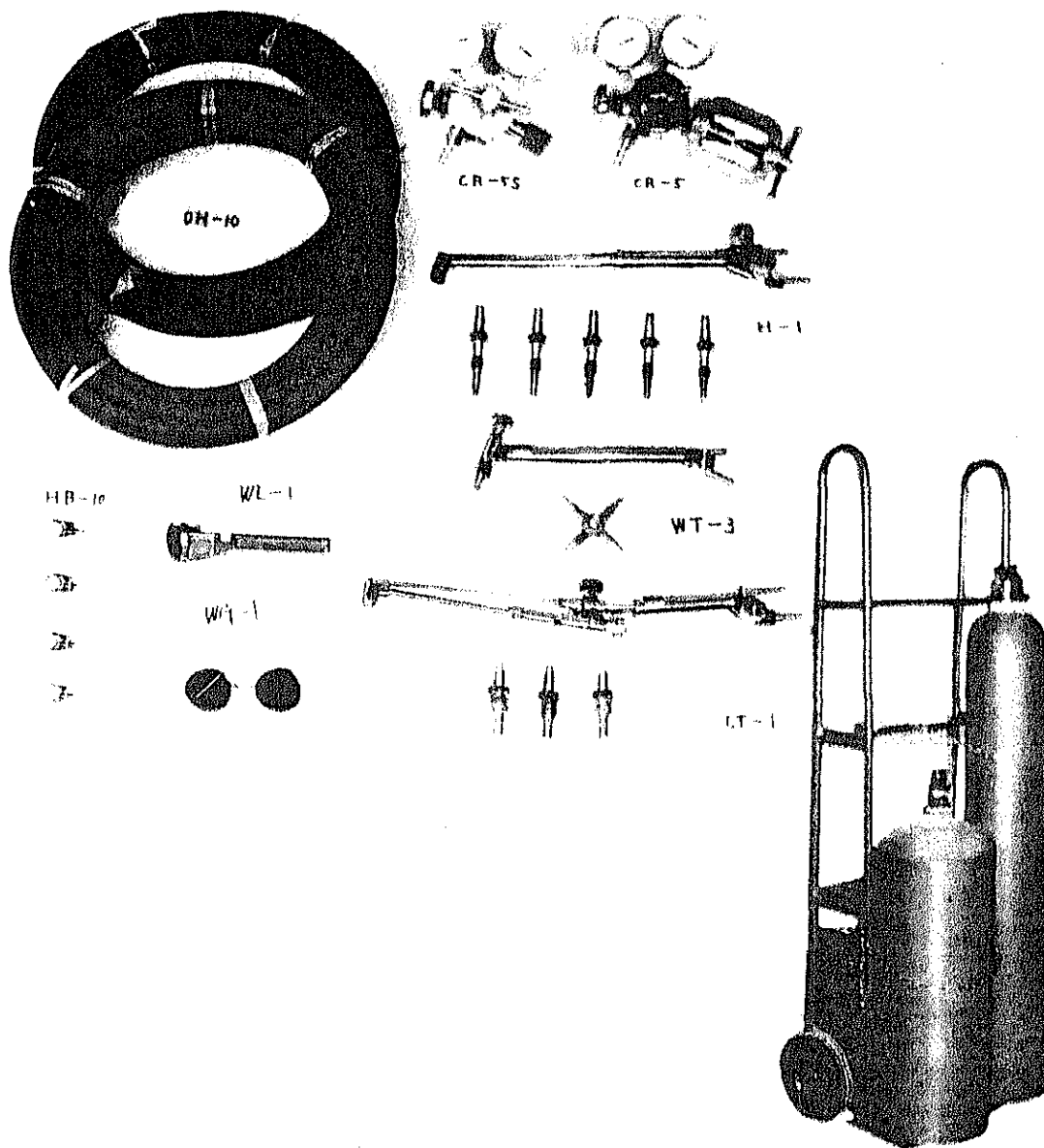

CONSTRUCTION PROJECT OF		DATE
AUTOMOBILE REPAIR & MAINTENANCE WORKSHOP IN BANGLADESH		SCALE
TITLE OF DRAWING		ORG. NO.
JAPAN INTERNATIONAL COOPERATION AGENCY		—

1-1-3

Item No. 10

Name Air Disc Grinder

Type M-70S

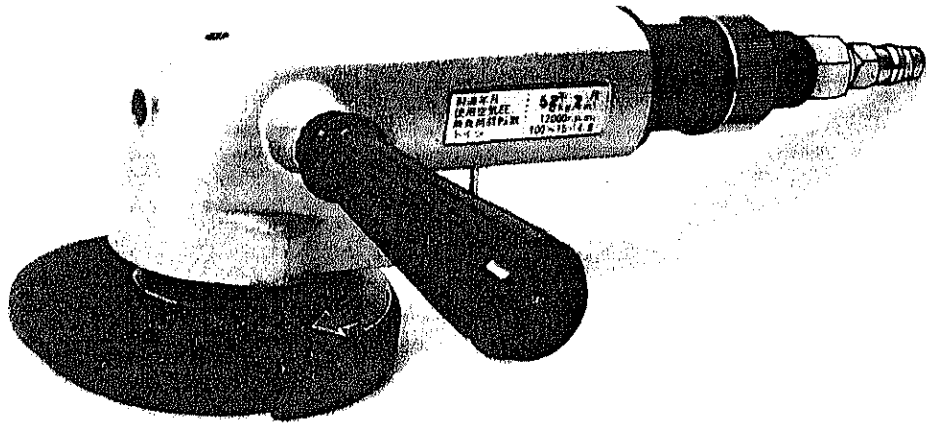

CONSTRUCTION PROJECT OF AUTOMOBILE REPAIR & MAINTENANCE WORKSHOP IN BANGLADESH	DATE
	SCALE
TITLE OF DRAWING	DRG. NO. —
JAPAN INTERNATIONAL COOPERATION AGENCY	

---1-1-3---

Item No. 12

Name Service Creeper

Type SC-5B

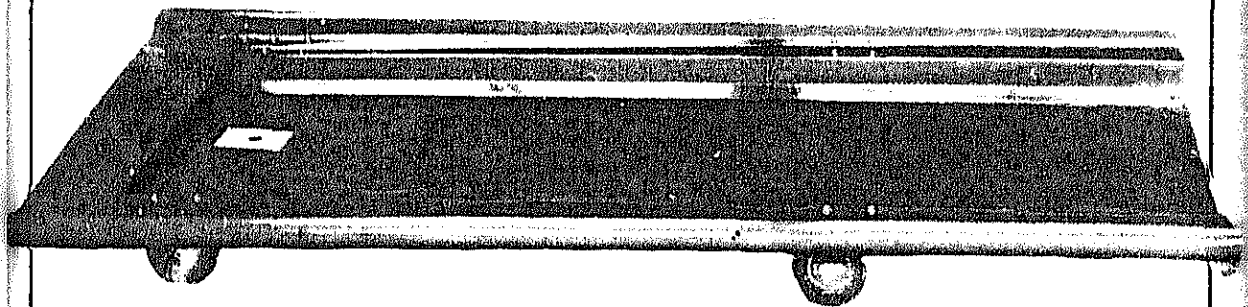

CONSTRUCTION PROJECT OF		DATE
AUTOMOBILE REPAIR & MAINTENANCE WORKSHOP IN BANGLADESH		SCALE
TITLE OF DRAWING		DRG. NO.
JAPAN INTERNATIONAL COOPERATION AGENCY		

1-1-3

Item No. 14

Name Pilot Bearing Puller

Type PB-100

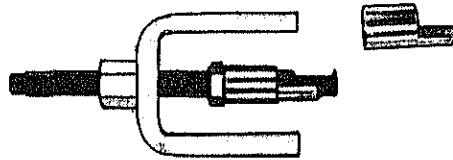

CONSTRUCTION PROJECT OF AUTOMOBILE REPAIR & MAINTENANCE WORKSHOP IN BANGLADESH	DATE
	SCALE
TITLE OF DRAWING	ORG. NO. -
JAPAN INTERNATIONAL COOPERATION AGENCY	

1-1-3

Item No. 15

Name Slide Hammer Puller

Type G-60

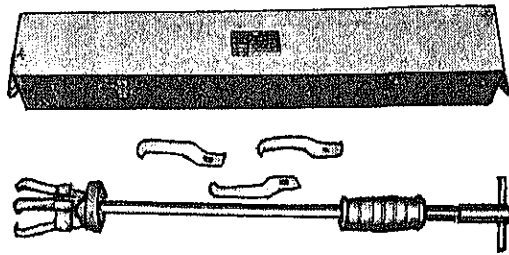

CONSTRUCTION PROJECT OF		DATE
AUTOMOBILE REPAIR & MAINTENANCE WORKSHOP IN BANGLADESH		SCALE
TITLE OF DRAWING		DRG. NO. —
JAPAN INTERNATIONAL COOPERATION AGENCY		

1-1-3

Item No. 16

Name Tube Flaring & Cutting Tool

Type TF-200W

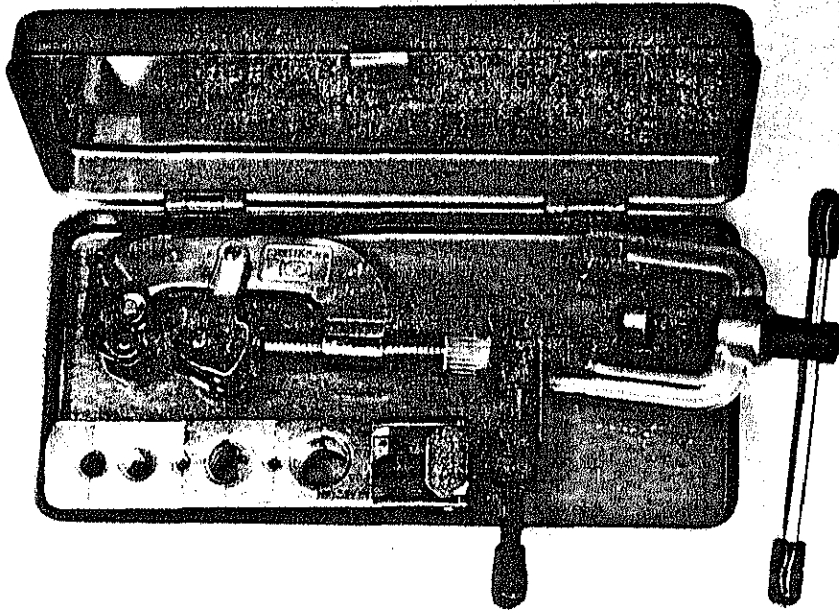

CONSTRUCTION PROJECT OF AUTOMOBILE REPAIR & MAINTENANCE WORKSHOP IN BANGLADESH	DATE
	SCALE
TITLE OF DRAWING	ORG. NO. —
JAPAN INTERNATIONAL COOPERATION AGENCY	

1-1-3

Item No. 17

Name Universal Wheel Hub Puller

Type T-75

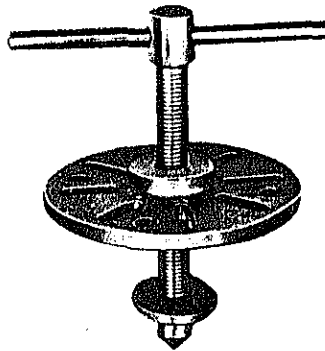

CONSTRUCTION PROJECT OF		DATE
AUTOMOBILE REPAIR & MAINTENANCE WORKSHOP IN BANGLADESH		SCALE
TITLE OF DRAWING		DRG. NO.
JAPAN INTERNATIONAL COOPERATION AGENCY		-

1-1-3
Item No. I8
Name Drum Greaser
Type DL-142

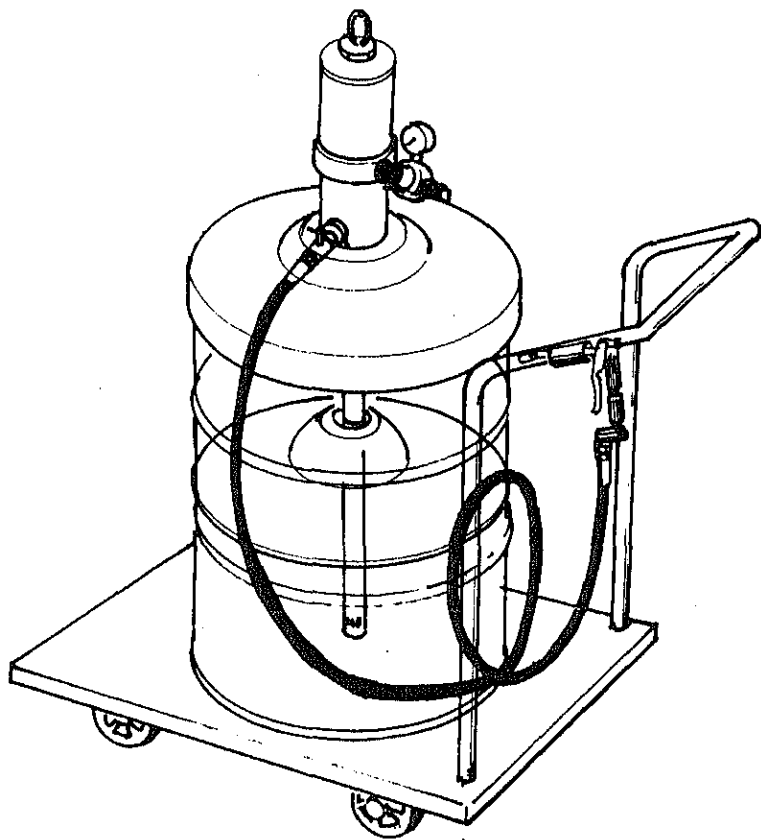

CONSTRUCTION PROJECT OF AUTOMOBILE REPAIR & MAINTENANCE WORKSHOP IN BANGLADESH	DATE
	SCALE
TITLE OF DRAWING	ORG. NO.
	-
JAPAN INTERNATIONAL COOPERATION AGENCY	

1-1-3

Item No. 19

Name Universal Jack

Type UJ-500

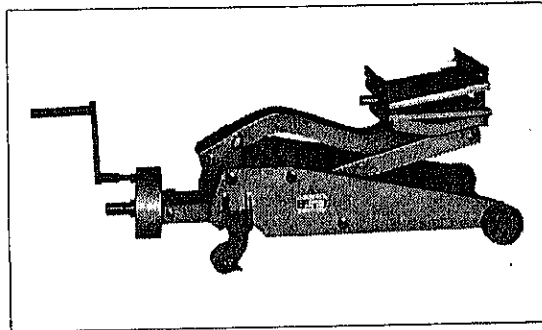

CONSTRUCTION PROJECT OF AUTOMOBILE REPAIR & MAINTENANCE WORKSHOP IN BANGLADESH	DATE
	SCALE
TITLE OF DRAWING	DRG. NO. —
JAPAN INTERNATIONAL COOPERATION AGENCY	

1-1-3

Item No. 20

Name Socket Wrench Set

Type HD-290M

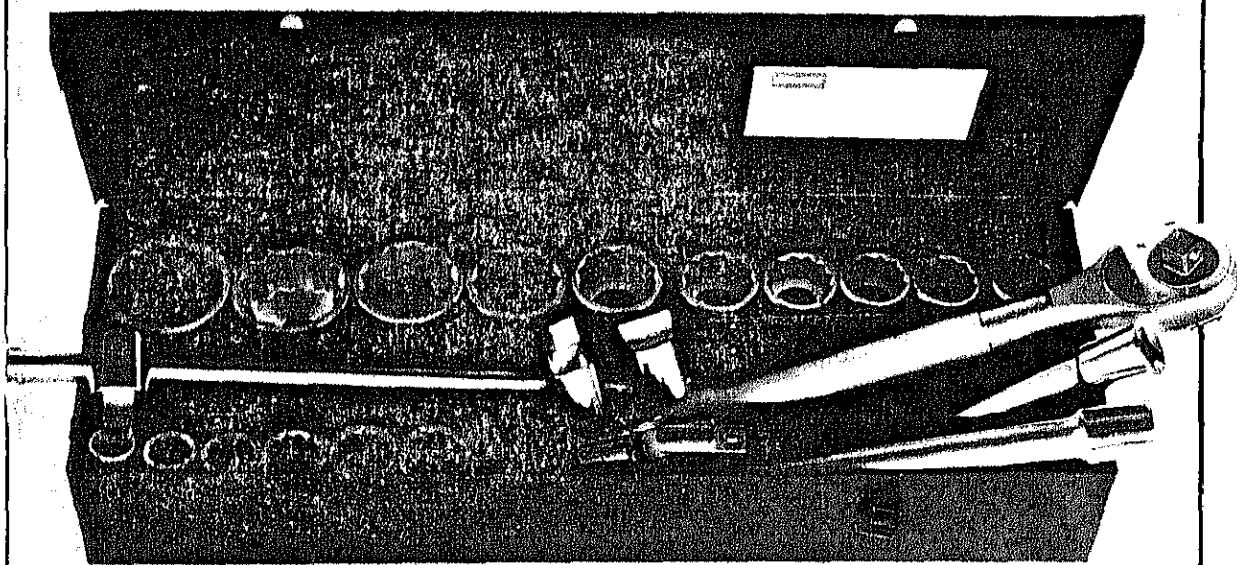

CONSTRUCTION PROJECT OF AUTOMOBILE REPAIR & MAINTENANCE WORKSHOP IN BANGLADESH	DATE
	SCALE
TITLE OF DRAWING	ORG. NO.
JAPAN INTERNATIONAL COOPERATION AGENCY	

---1-1-3---

Item No. 21

Name Diff. Jack

Type DJ-50

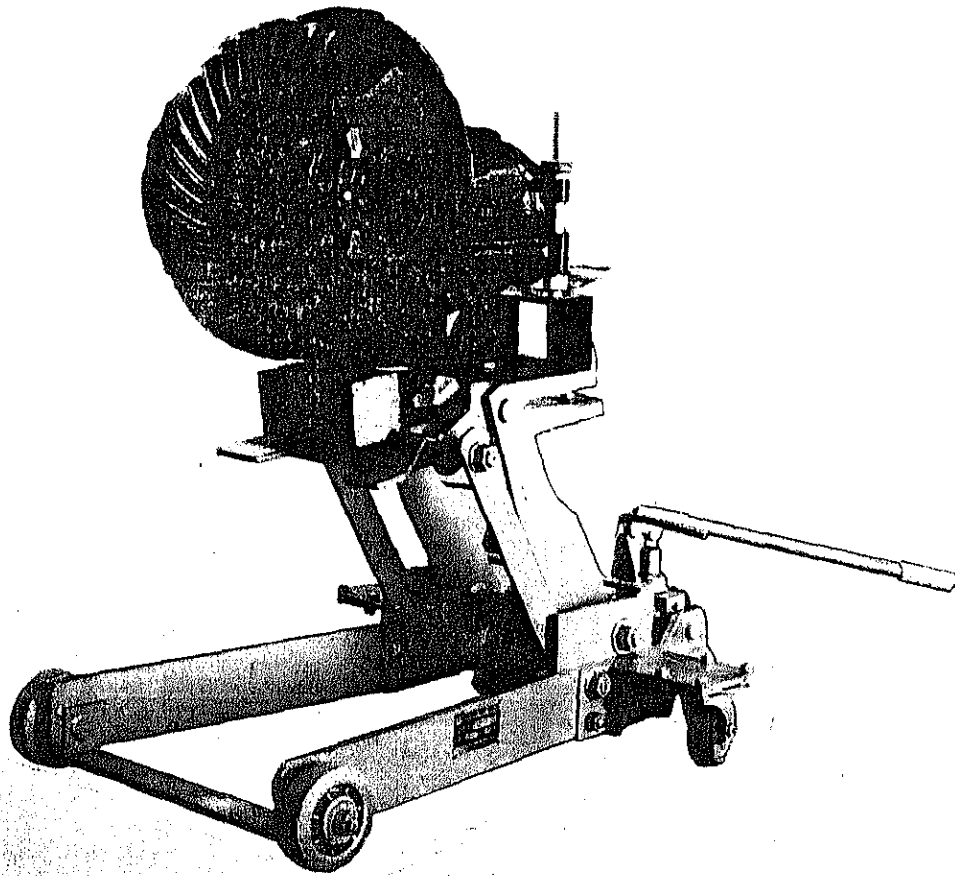

CONSTRUCTION PROJECT OF AUTOMOBILE REPAIR & MAINTENANCE WORKSHOP IN BANGLADESH	DATE
	SCALE
TITLE OF DRAWING	ORG. NO. ---
JAPAN INTERNATIONAL COOPERATION AGENCY	

1-1-3

Item No. 22

Name Gasket Cutting Punch Set

Type H-75

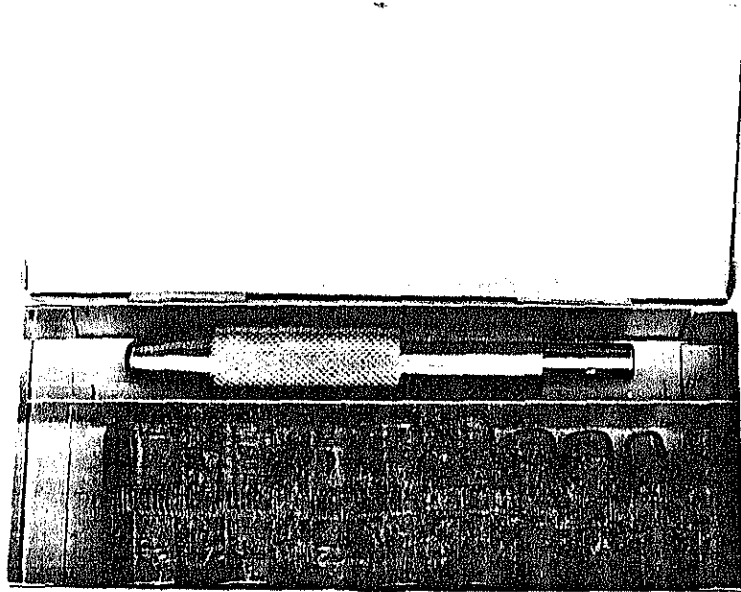

CONSTRUCTION PROJECT OF AUTOMOBILE REPAIR & MAINTENANCE WORKSHOP IN BANGLADESH	DATE
	SCALE
TITLE OF DRAWING	DRG. NO. —
JAPAN INTERNATIONAL COOPERATION AGENCY	

---1-1-3---

Item No. 24

Name Air Chisel Set

Type D-210

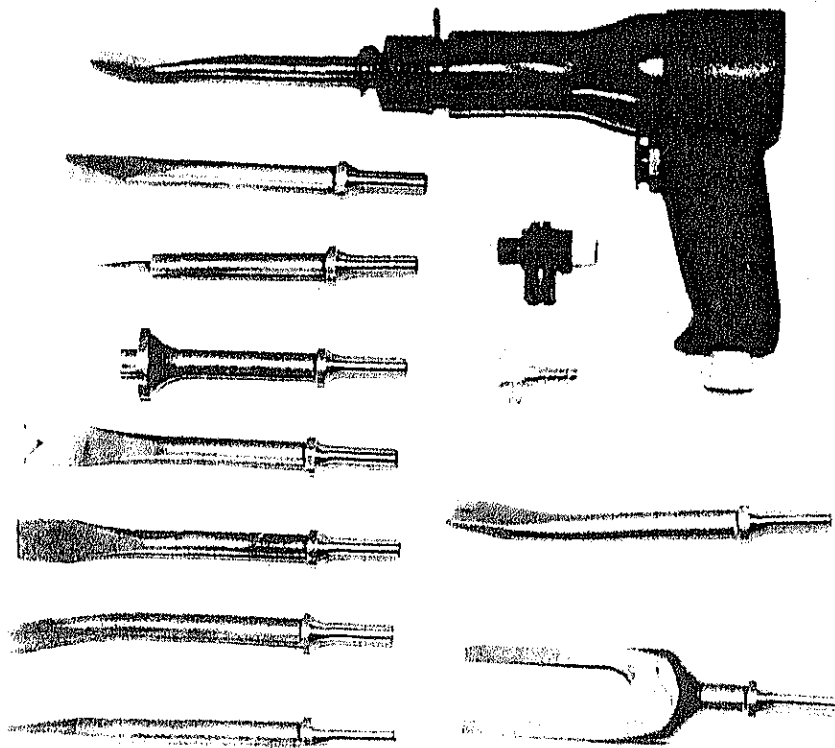

CONSTRUCTION PROJECT OF		DATE
AUTOMOBILE REPAIR & MAINTENANCE WORKSHOP IN BANGLADESH		SCALE
TITLE OF DRAWING		ORG. NO. —
JAPAN INTERNATIONAL COOPERATION AGENCY		

1-1-3

Item No. 25

Name Auto Lub Set

Type AL-205

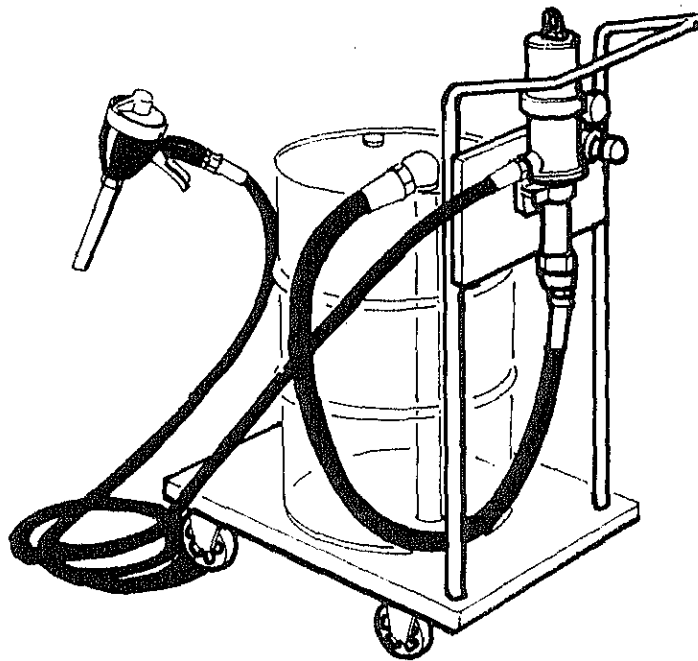

CONSTRUCTION PROJECT OF AUTOMOBILE REPAIR & MAINTENANCE WORKSHOP IN BANGLADESH		DATE
TITLE OF DRAWING		SCALE
		ORG. NO.
JAPAN INTERNATIONAL COOPERATION AGENCY		

1-1-3

Item No. 26

Name Pipe Wrench

Type PW-6

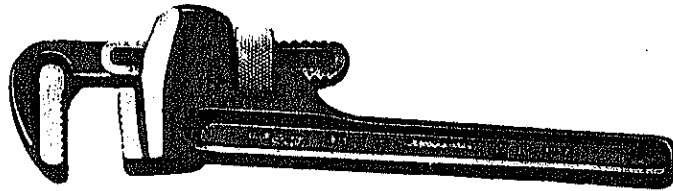

CONSTRUCTION PROJECT OF AUTOMOBILE REPAIR & MAINTENANCE WORKSHOP IN BANGLADESH	DATE
	SCALE
TITLE OF DRAWING	ORG. NO. —
JAPAN INTERNATIONAL COOPERATION AGENCY	

1-1-3

<u>Item No.</u>	<u>27</u>
<u>Name</u>	<u>Pipe Wrench</u>
<u>Type</u>	<u>PW-14</u>

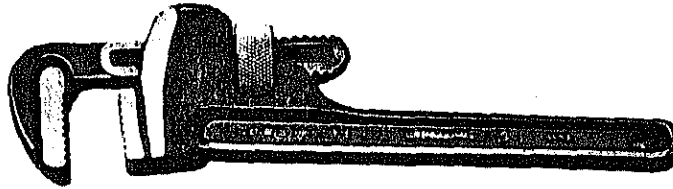

CONSTRUCTION PROJECT OF	DATE
AUTOMOBILE REPAIR & MAINTENANCE WORKSHOP IN BANGLADESH	SCALE
TITLE OF DRAWING	DRG. NO. —
JAPAN INTERNATIONAL COOPERATION AGENCY	

---1-1-3---

Item No. 28

Name Pipe Wrench

Type PW-36

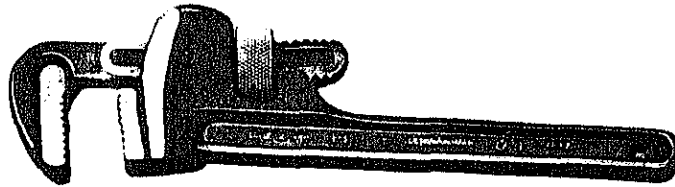

CONSTRUCTION PROJECT OF AUTOMOBILE REPAIR & MAINTENANCE WORKSHOP IN BANGLADESH		DATE
TITLE OF DRAWING		SCALE
		ORG. NO. -
JAPAN INTERNATIONAL COOPERATION AGENCY		

1-1-3

Item No. 30

Name Air Meter

Type AT-300

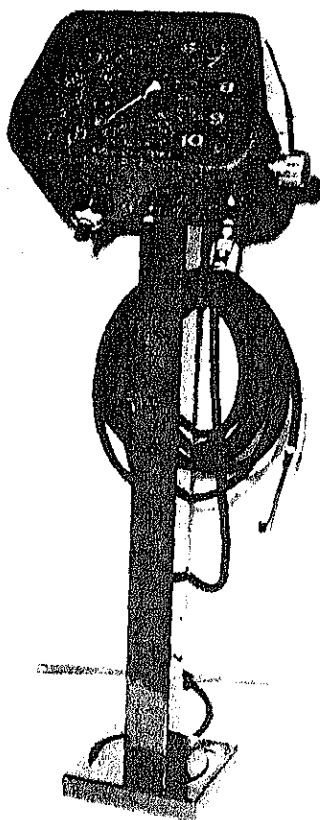

CONSTRUCTION PROJECT OF AUTOMOBILE REPAIR & MAINTENANCE WORKSHOP IN BANGLADESH	DATE
	SCALE
TITLE OF DRAWING	ORG. NO. -
JAPAN INTERNATIONAL COOPERATION AGENCY	

1-1-3

Item No.	31
Name	U Bolt Wrench
Type	UB-2224/2632



CONSTRUCTION PROJECT OF AUTOMOBILE REPAIR & MAINTENANCE WORKSHOP IN BANGLADESH	DATE
	SCALE
TITLE OF DRAWING	DRG. NO. -
JAPAN INTERNATIONAL COOPERATION AGENCY	

1-1-3

Item No. 32

Name Air Impact Wrench

Type AW-4000T

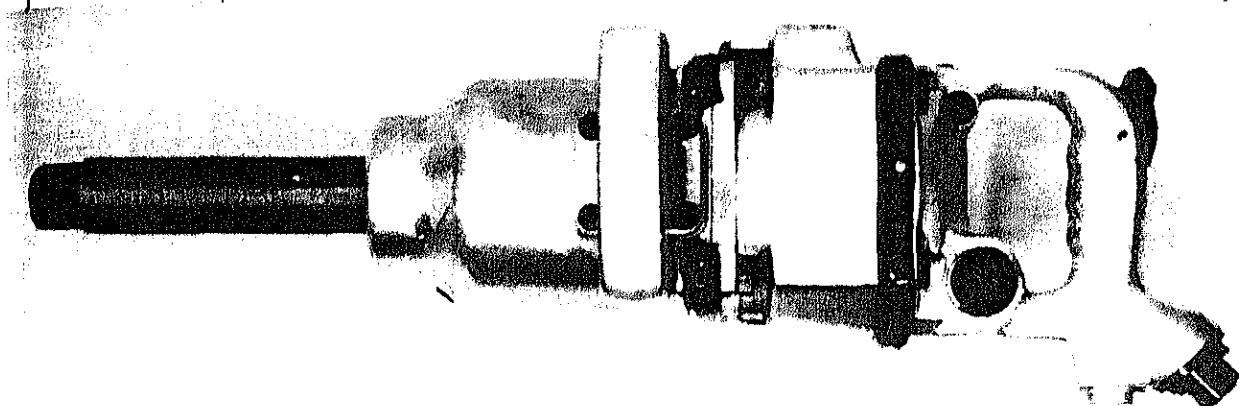

CONSTRUCTION PROJECT OF		DATE
AUTOMOBILE REPAIR & MAINTENANCE WORKSHOP IN BANGLADESH		SCALE
TITLE OF DRAWING		DRG. NO. —
JAPAN INTERNATIONAL COOPERATION AGENCY		

1-1-3

Item No. 33

Name Air Impact Wrench

Type AW-2000

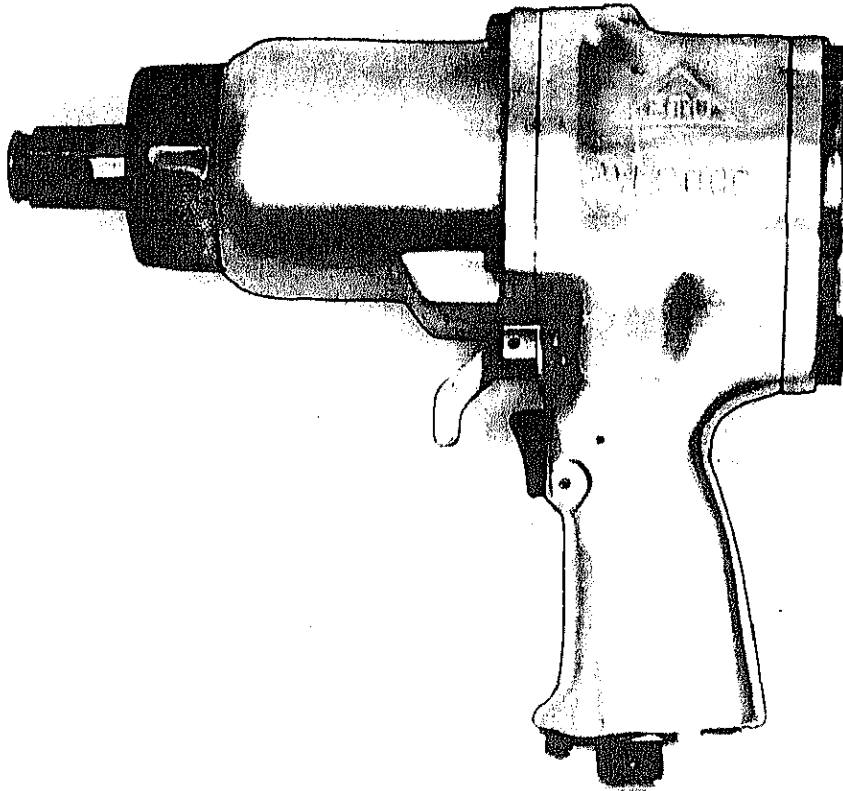

CONSTRUCTION PROJECT OF AUTOMOBILE REPAIR & MAINTENANCE WORKSHOP IN BANGLADESH	DATE
	SCALE
TITLE OF DRAWING	DRG. NO. —
JAPAN INTERNATIONAL COOPERATION AGENCY	

1-1-3

Item No. 34

Name Air Impact Wrench

Type AW-1600T

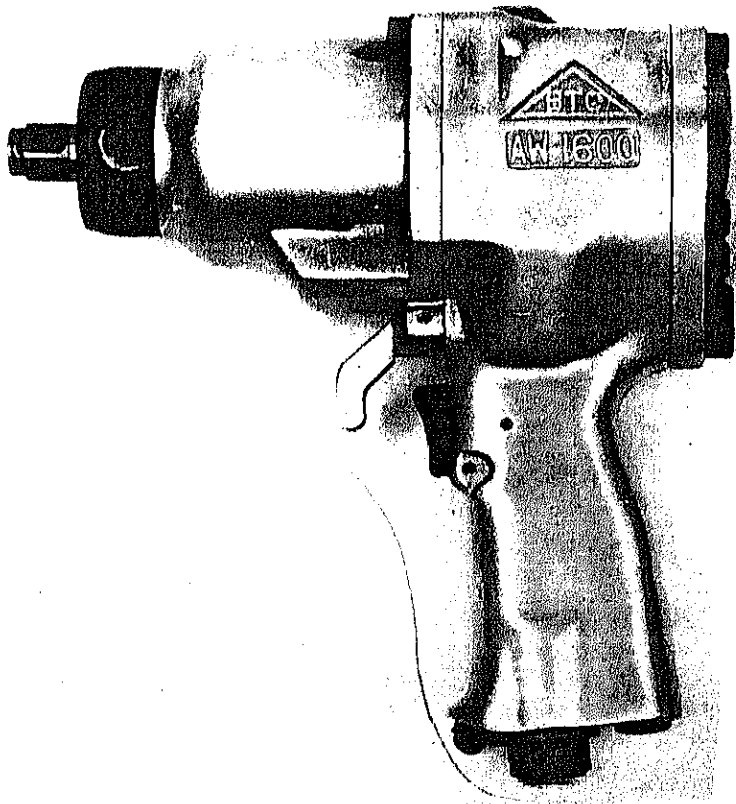

CONSTRUCTION PROJECT OF		DATE
AUTOMOBILE REPAIR & MAINTENANCE WORKSHOP IN BANGLADESH		SCALE
TITLE OF DRAWING		DRG. NO. —
JAPAN INTERNATIONAL COOPERATION AGENCY		

1-1-3

Item No. 37

Name Fork Lift

Type FG-10

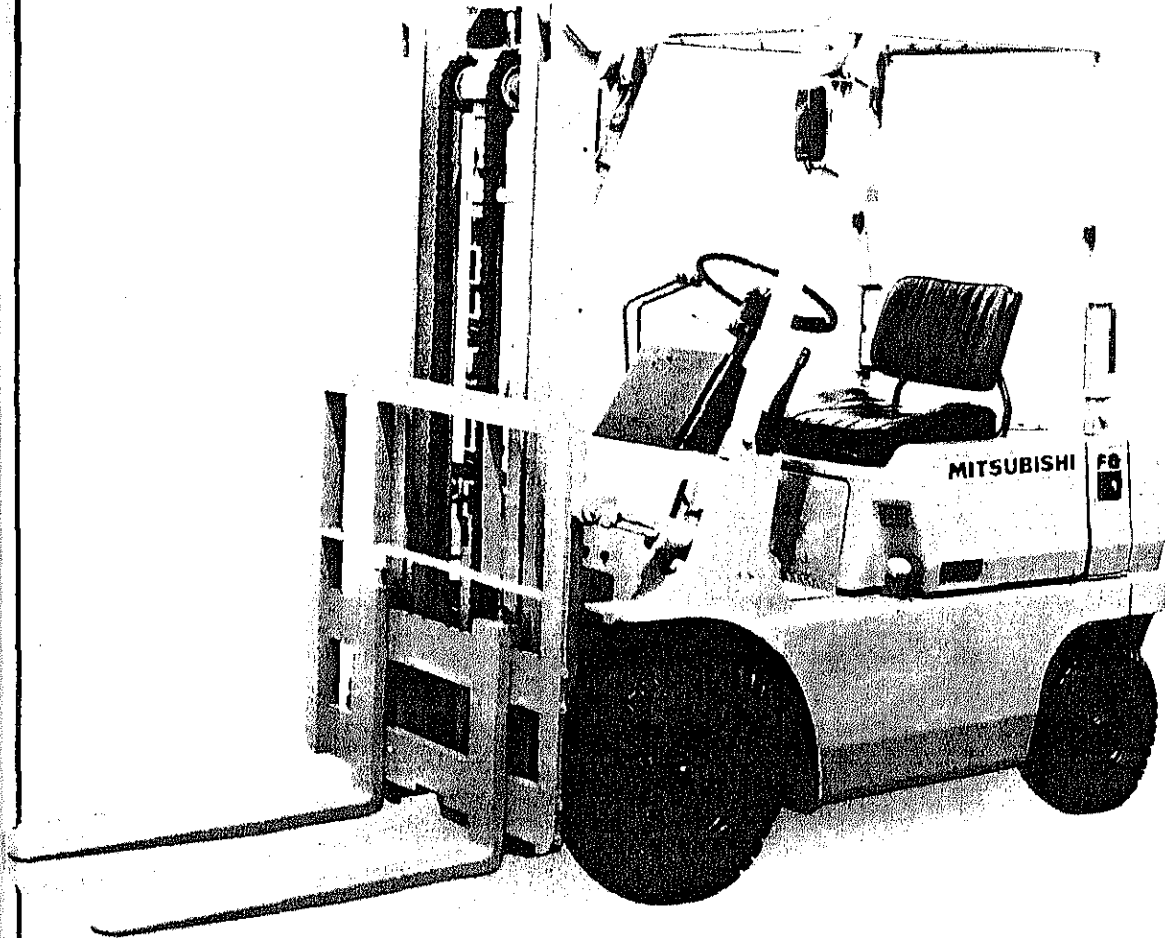

CONSTRUCTION PROJECT OF AUTOMOBILE REPAIR & MAINTENANCE WORKSHOP IN BANGLADESH	DATE
	SCALE
TITLE OF DRAWING	ORG. NO.
JAPAN INTERNATIONAL COOPERATION AGENCY	

1-1-3
Item No. 39
Name Drain Cart
Type DC-77

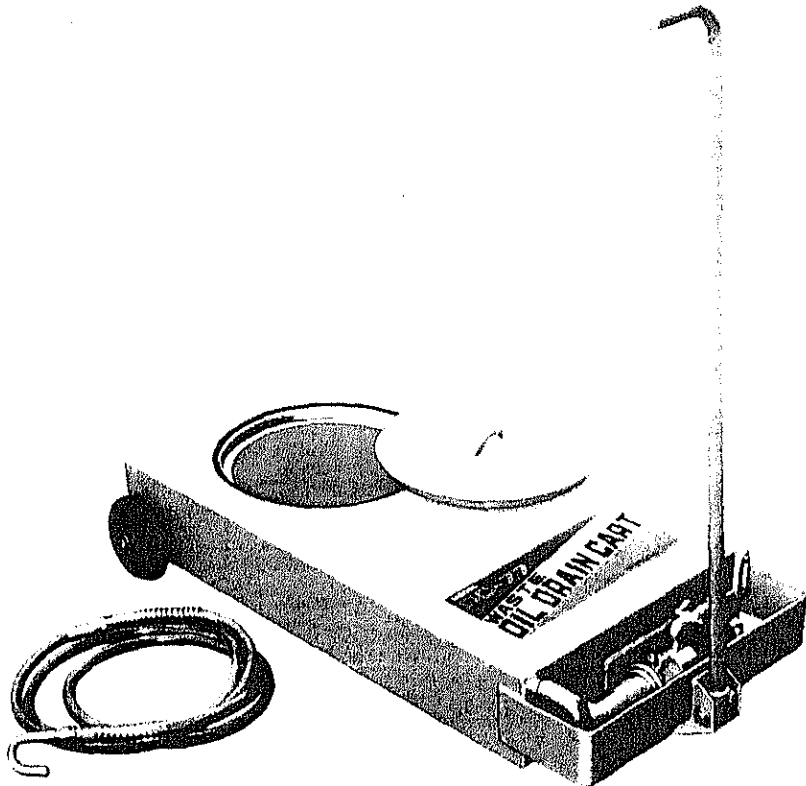

CONSTRUCTION PROJECT		DATE
OF		SCALE
AUTOMOBILE REPAIR & MAINTENANCE WORKSHOP		
IN BANGLADESH		
TITLE OF DRAWING		ORG. NO.
		-
JAPAN INTERNATIONAL COOPERATION AGENCY		

1-1-3

Item No. 40

Name Electric Pencil

Type EP-A

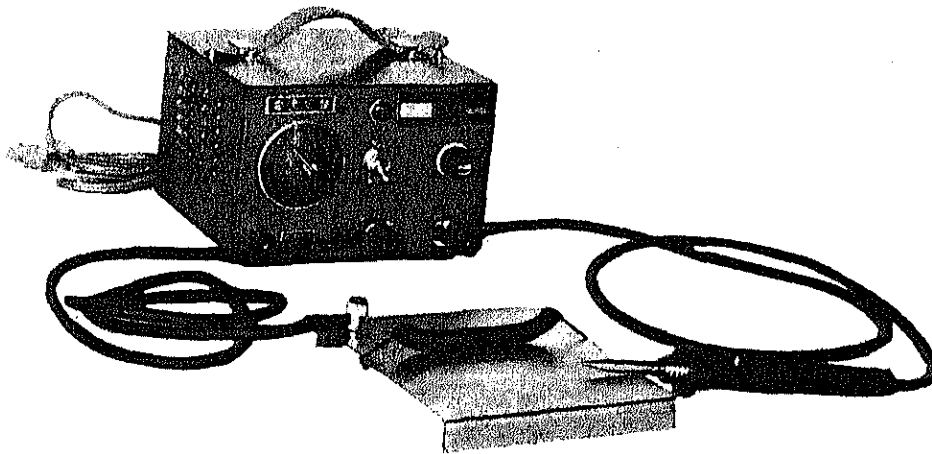

CONSTRUCTION PROJECT OF AUTOMOBILE REPAIR & MAINTENANCE WORKSHOP IN BANGLADESH	DATE
	SCALE
TITLE OF DRAWING	DRG. NO. -
JAPAN INTERNATIONAL COOPERATION AGENCY	

---1-1-3---

Item No. 41

Name Impact Driver

Type #2600

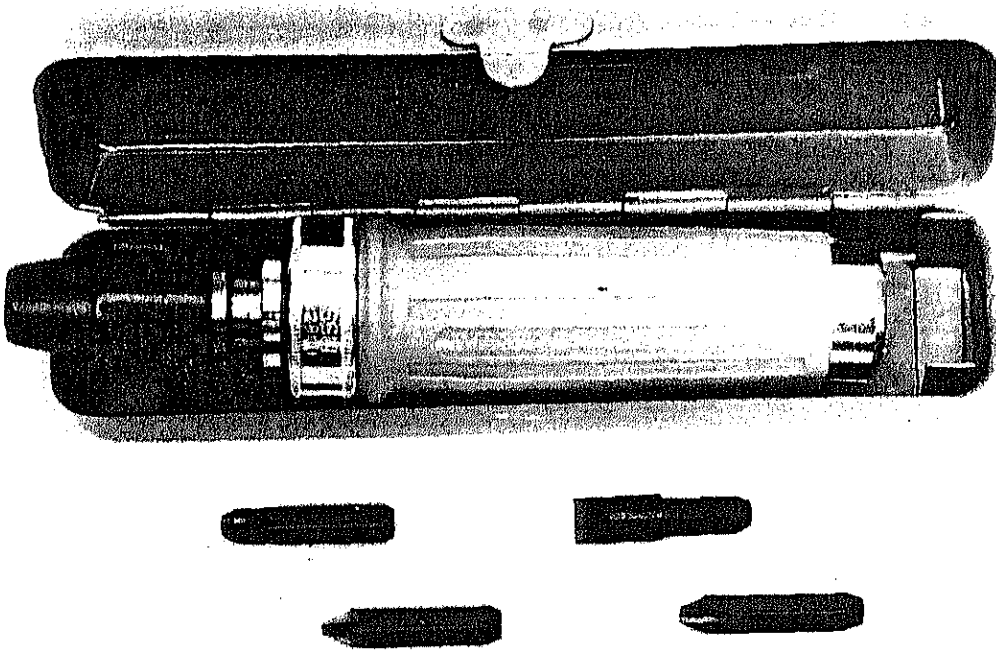

CONSTRUCTION PROJECT OF	DATE
AUTOMOBILE REPAIR & MAINTENANCE WORKSHOP IN BANGLADESH	SCALE
TITLE OF DRAWING	DRG. NO. —
JAPAN INTERNATIONAL COOPERATION AGENCY	

1-1-3

Item No. 45

Name Circuit Tester

Type TH-20

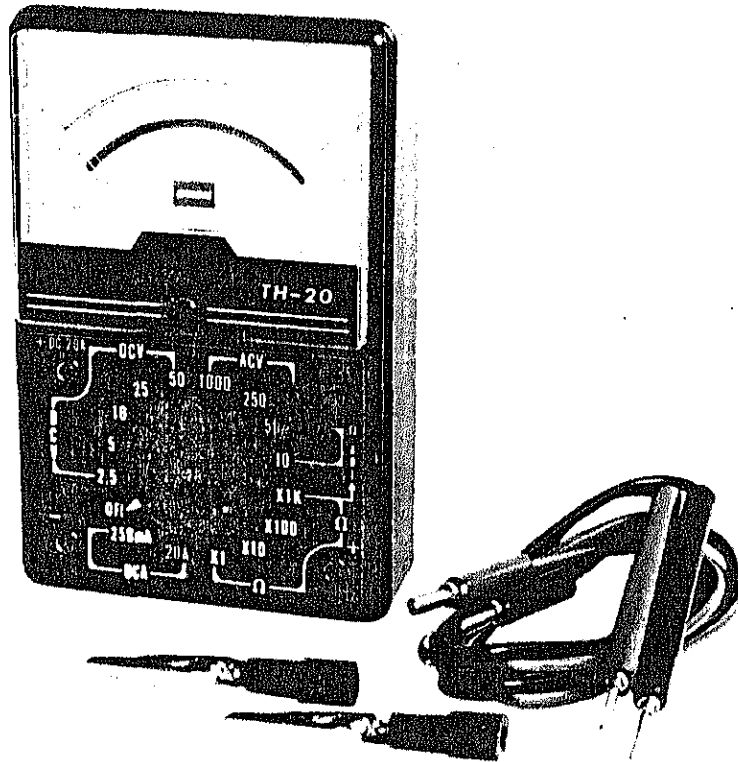

CONSTRUCTION PROJECT OF AUTOMOBILE REPAIR & MAINTENANCE WORKSHOP IN BANGLADESH		DATE
TITLE OF DRAWING		SCALE
		DRG. NO. —
JAPAN INTERNATIONAL COOPERATION AGENCY		

1-1-3

Item No. 46

Name Tool Cabinet Set

Type D-3000

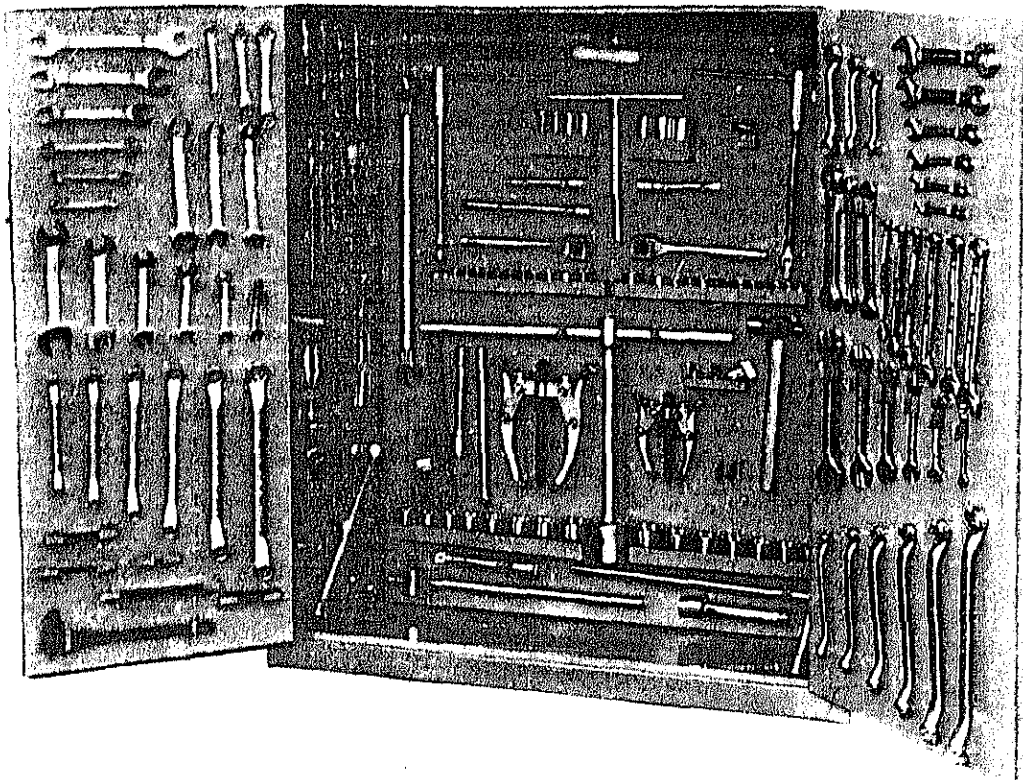

CONSTRUCTION PROJECT		DATE
OF		SCALE
AUTOMOBILE REPAIR & MAINTENANCE WORKSHOP		ORG. NO.
IN BANGLADESH		—
TITLE OF DRAWING		
JAPAN INTERNATIONAL COOPERATION AGENCY		