

# TEST PIT 11

Location: Near National Institute of Public Health

Excavation Date: July 21th, 2004

Identified Working Infrastructure(s):

Identified Archaeological Feature(s):

Recovered Artifacts: 326

Stoneware: 112, Earthenware: 146, Imported ceramics: 37, Bone: 1,

Stone tool: 3, Stone: 8, Brick: 13, Metal Object: 3, Roof Tile: 4,

Architectural Ornament: 1

Note:

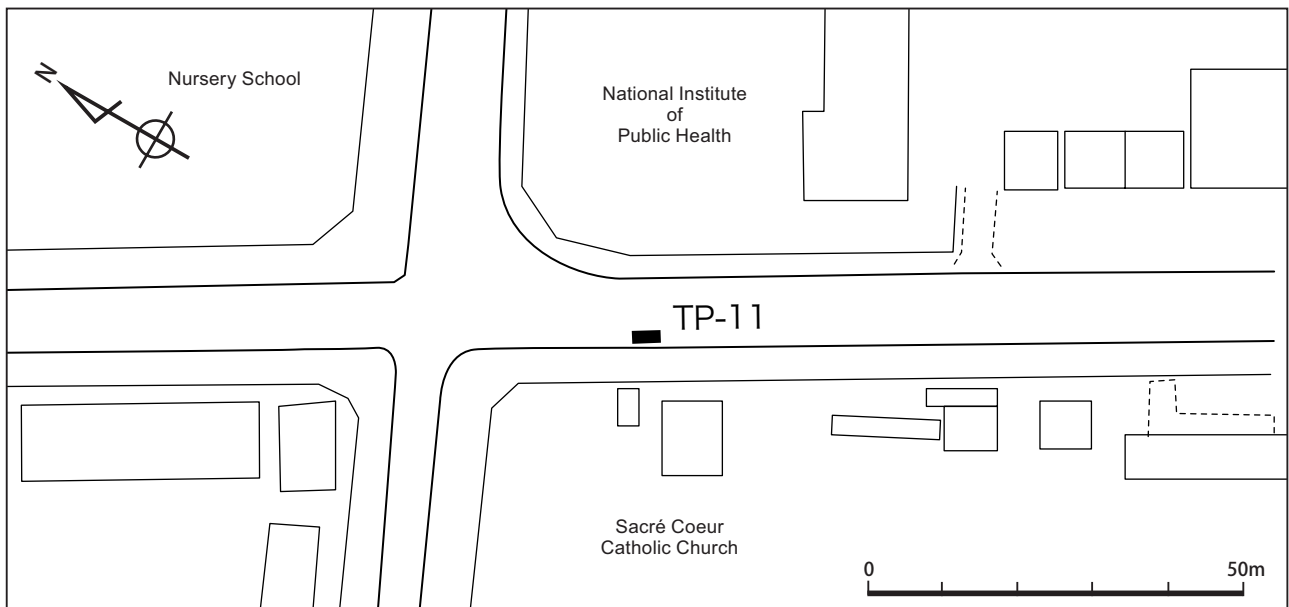
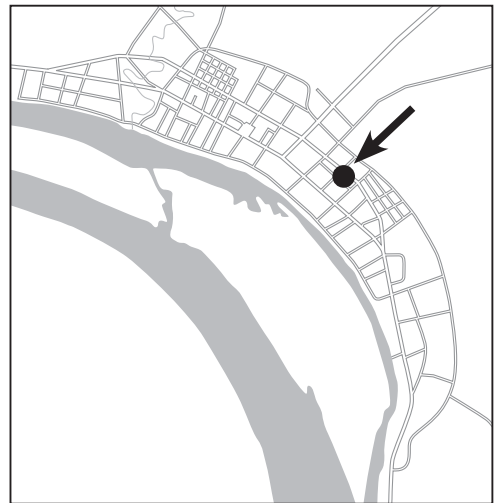

**Point E11-18**  
Coordinates:  
X=87,613.075  
Y=47,418.539  
EL=169.21m

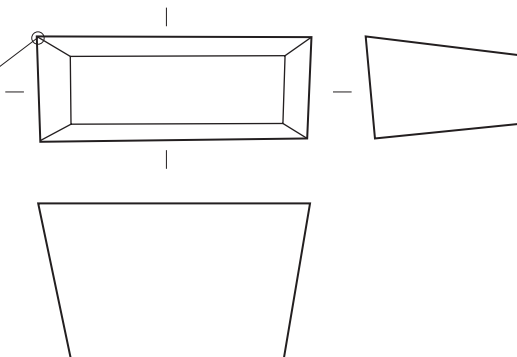

### Test Pit Dimention (max.)

Length: 3.63m

Width: 1.4m

Depth: 2.1m

Surface Area: 5.08m<sup>2</sup>

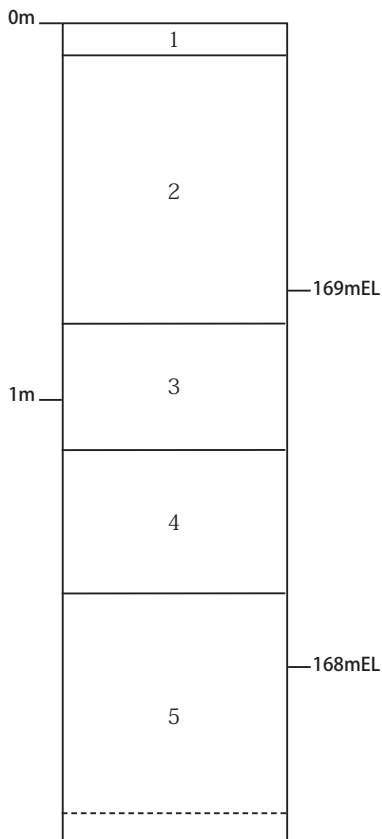

**Explanation of Soil Layers**

- 1 Asphalt: Present road surface.
- 2 Pebble/Laterite soil: The sub-base layer for the present road surface.
- 3 Dark grey silty clay. Artifacts found from this layer.
- 4 Light yellow grey silty clay: Uniform and with no inclusion.
- 5 Light grey clay: Uniform and with no inclusion.



**Artifacts**

**Roof tiles**

Four shards of thin flat roof tiles were unearthed. 1 of them is different from other normal ones because of the position and shape of the stopper (TP11-R1).

**Bricks**

Thirteen broken blocks of bricks were unearthed. Each of 3 blocks of them keeps its width and thickness (see table below).

Width	Thickness
112	52
127	49
132	47

Measurments of bricks from TP11 (mm)

**Metal objects**

Three rusted fragments of plates were unearthed.



Vicinity of Test Pit 11



Removing artifact

## Architectural ornaments(?)

1 small block of stoneware with ornament like a molding was unearthed (TP11-A1a, b). Its original position nor function are unknown.

## Stoneware

There are considerable numbers of ceramic shards recovered at TP011.

Stoneware shards count 112 pieces in total. They are classified and counted in each shape class as follows; bowl type wares: 48 pieces (seven pieces of outward angled rim, 17 pieces of straight standing or smooth curved rim, 22 pieces of body and two pieces of base), mortar type wares usually with thicker rims and bodies than the bowl types: nine pieces (three pieces of rim part and six pieces of body part), small bowl with grating surface on the inside: 2 pieces (one piece of rim and one piece of body), jar type wares: 50 pieces (five pieces of base part, 44 pieces of body part and one piece of rim part), oil lamp: one piece, and smoking pipe: two pieces (one piece of the bowl part and one piece of the stem part).

Most of the above-listed findings are small fragments and there is no specimen with complete form. The contents of shape classes about bowl, mortar and jar typed wares are almost common to the findings from TP02.

TP11-S1 is a rim to body part of the small bowl with grater on the interior. Its estimated rim size measures 13.2cm at top end of the outer rim. The paste is dark gray coloured, quite solid but coarse. It includes small black particles. There are incised decoration of narrow and fine horizontal lines in 1~2 mm pitch and several vertical lines to make grating face. The same type wares with graters are also found at the kiln site where TP02 was located, it could be understood as a kind of stonewares made in local. Generally speaking, or according to the example studies about mortars with grater in Japan, these typed wares have been basically used for grinding or braying vegetables and others as a kind of historical cooking tool. This specimen, however, has not so sharp edged teeth that it is unlikely serviceable or useful for processing foods. Furthermore, the surface on grating part of the specimen dose not seem to be worn out or used well at all. It is, therefore, still unclear about the actual usage of these typed wares.

TP11-S2 is a part of oil lamp. The specimen consists of shallow dish (or saucer to reserve oil) part and central post perforated for raising and supporting wicks at the top. It is generally assumed that they were used as oil lamps and also manufactured in local. The height of its central post measures 6.9cm from the interior bottom of the saucer. The drilled hole at the top of post measures 7~8mm in diameter at both exits. Its estimated size at the base measured 5.5cm in diameter of the outline circle at its bottom foot. The paste of the specimen is dark gray colour, relatively solid. There is no evidence of soot or burnt oil observed on the remained part.

## Imported ceramics

Imported ceramics unearthed from TP011 count 37 pieces in total. The findings varies widely in their origin and dating, which includes modern products also. Most of them are so small fragments that it is quite difficult to identify each specimen precisely. Their temporary classification with numbers are as follows; Chinese underglazed blue and white wares in Ming dynasty or around 16th century: five pieces (three pieces of bowls and two pieces of plates), Chinese underglazed blue and white wares in Qing dynasty or after the late of 17th century: 13 pieces (12 pieces of bowls and one piece of plates), white porcelain in modern period probably in 19th to 20th centuries: three pieces of saucer or dish, underglazed blue and white porcelain manufactured in China or Vietnam(?) after 18th century: three pieces (two pieces of bowl and one piece of lid) celadon glazed stoneware probably made in Thai around 15th century: one piece of bowl, underglaze iron painted ware made in Thai during 15th to 16th centuries: one piece of bowl Brown glazed stoneware probably made Thai during 15th to 16th centuries: five pieces of large jars, two shards of which have paddled decorations, Vietnamese underglazed blue and white ware in 16th to the early 17th centuries: three pieces of bowls and two pieces of plates, and Japanese porcelain with underglazed blue and white decoration: one piece of bottle.

TP11-I1 is a body part of small bottle. Its paste is pure white coloured, very fine grained and solid. The underglaze decoration of dragon and arabesque motives was made by not hand painting but so-called copper plate printing (transferring) which technique was newly developed in the 19th century. The colour of decoration is clear indigo blue

for using chloride cobalt pigment. The glaze is transparent, very thin in layer and shiny. Depends on the characteristics of paste, design and technique of underglaze decoration, the specimen could be identified Japanese product probably fired in Seto kilns during the end of 19th to early 20th centuries.

### Earthenware

There are comparatively many shards of earthenware recovered at the Test Pit 11, which count 146 pieces in total, while there is no specimen remained complete form. The shards of rim parts counting 23 pieces demonstrate several variations in proportions of rims and shape classes of wares. As rough classification, major specimens can be identified as large jars which have two types of rim shapes; straight-standing neck part with protruded (thicker) mouth-rim and slightly outward angled shape with small protruded edge as shown in the photo plate. Other several specimens are dish or shallow bowl shaped wares with gently curved wall. These dish typed wares seem to be used as oil lamps, as charcoal or soot clearly remains on the top end of the mouth-rims as shown in the photo plate. Other one specimen of base part (shown in the same photo plate) has a trace of central post at the center of interior bottom, which exists nearly same form as standard oil lamp of local-made stoneware.

On the other hand, there are quite many pieces (20 shards) of jar typed wares with characteristic impressed decorations of a series of short oblique lines, cross-stripes or herringbone-like motifs also recovered at TP11. These decorations varies in detailed motifs and also the tools for making decors as introduced in the photo plates. Furthermore, as a comparatively newer-dated earthenware, one piece of so-called “kendi” ware was recovered from the same TP11. This specimen remains only spout part. Its paste is light brownish orange in colour, fine-grained and rather solid. The exterior surface is painted in dark red. There is no decoration observed on the remained part. The “Kendi” ware is understood to be a traditional style vessel which has been produced and used for centuries up to modern period or even present days in almost all over the Southeast Asia.

### Stone tool

A fragment of schist stele was found (TP11-T1). One side is polished to make smooth surface, however, no design can be identified.

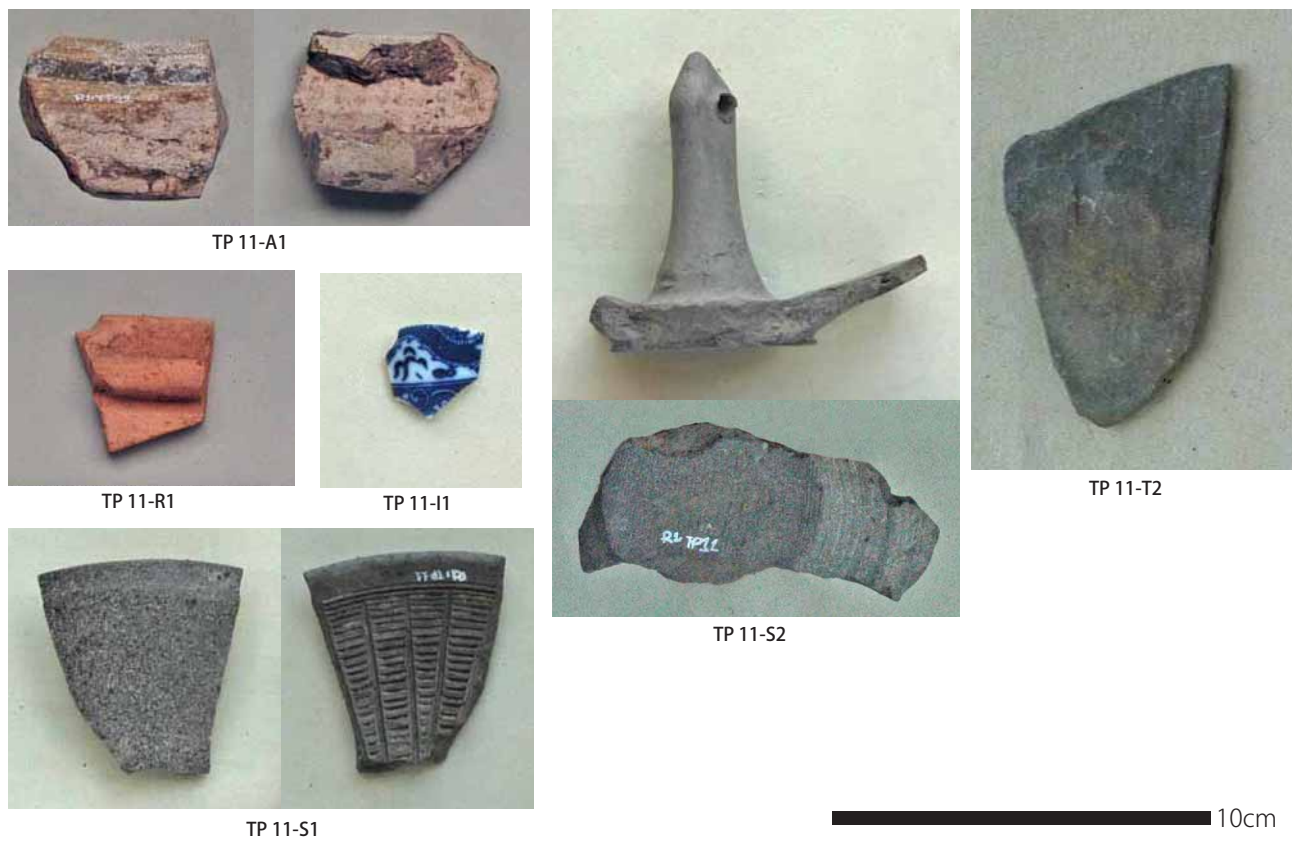





Earthenware from TP11 (1)



Earthenware from TP11 (2)

10cm

# TEST PIT 12

Location: Near Nursery School

Excavation Date: July 22, 2004

Identified Working Infrastructure(s): None

Identified Archaeological Feature(s): None

Identified Artifacts: 628

Stoneware: 43, Earthenware: 10, Imported ceramics: 11,

Stone tool: 1, Stones: 17, Brick: 55, Metal Objects: 103,

Roof Tiles: 280, Architectural Ornament: 4, Bone: 1, Others: 3.

Note: Within the range of presently non-existent Vat Gnotkeo.

An immense quantity of artifacts related to buddhism was unearthed.

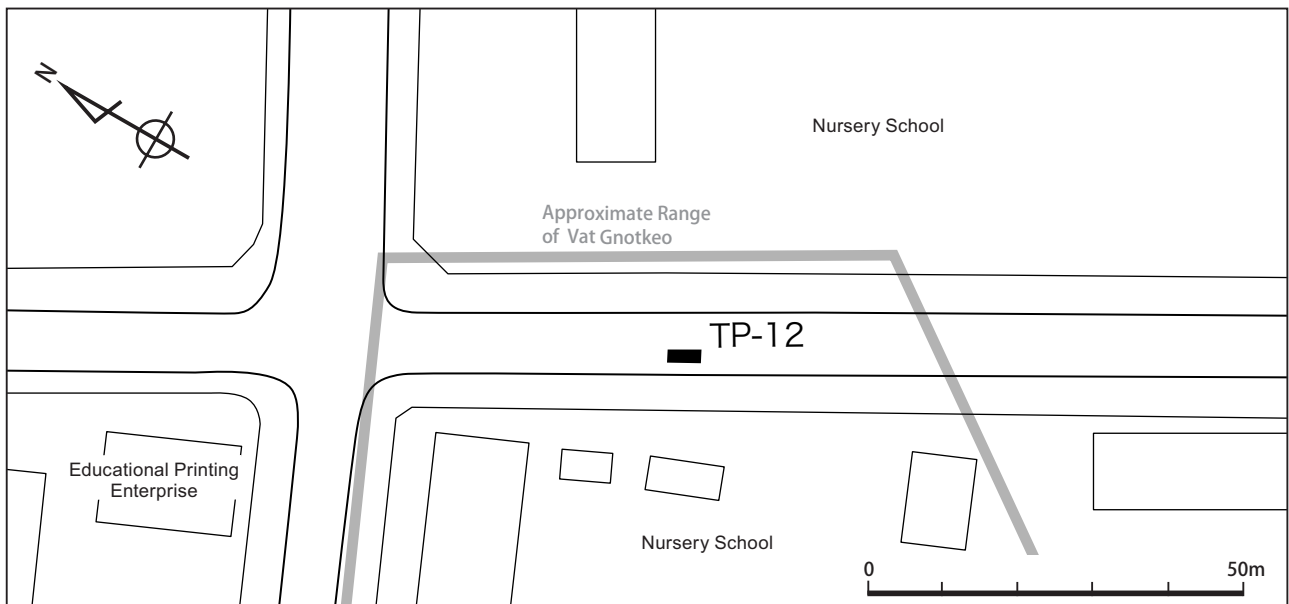
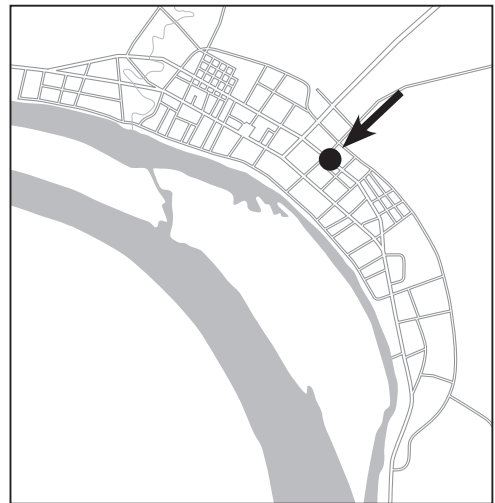

**Point E12-21**  
Coordinates:  
X=87,705.802  
Y=47,316.118  
EL=169.25m

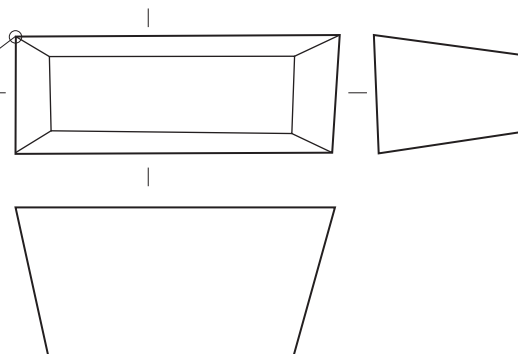

### Test Pit Dimention (max.)

Length: 4.34m

Width: 1.6m

Depth: 2.04m

Surface Area: 6.94m<sup>2</sup>

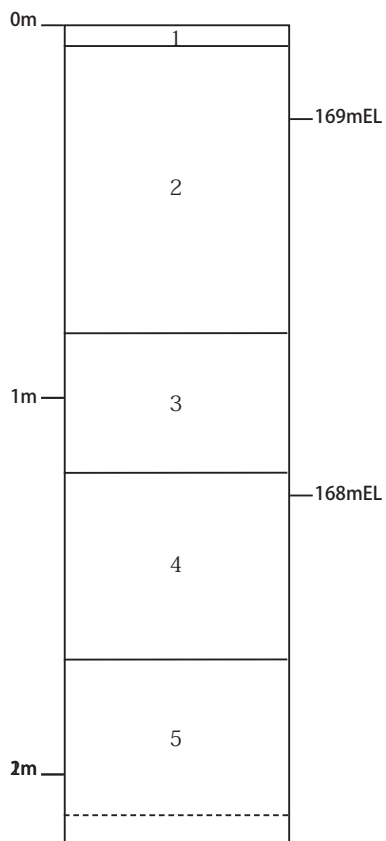

**Explanation of Soil Layers**

- 1 Asphalt: Present road surface.
- 2 Pebble/Laterite soil: The sub-base layer for the present road surface.
- 3 Dark grey silty clay. Artifacts found from this layer.
- 4 Light yellow grey silty clay: Uniform and with no inclusion.
- 5 Light grey clay: Uniform and with no inclusion.



View of the excavated area



Excavation in progress



Metal artifacts *in situ*



Cleaning artifact at the site



## General

Almost all of unearthed artifacts from this trench probably have a close relation to Vat Gnot Keo that had been located around here until beginning of 20th century.

## Artifacts

### Roof tiles

280 shards of the roof tiles were unearthed. 3 shards of them are parts of the flat eaves-end tiles and thicker than others (TP12-R1a, b). Each of 4 shards including one of the eaves-end tiles keeps its full width (see the list below, TP12-R2 to R4). 1 shard has the line carved figure on its surface (TP12-R5). Furthermore, 1 shard of a half-round tile (TP12-R6a to c) and 1 shard of side end of a flat tile which had been used with half-round ones together (TP12-R7a to c) were unearthed. The mortar adheres on the surfaces of 11 shards including 3 eaves-end tiles.

### Bricks

55 broken blocks of bricks were unearthed. Each of 15 blocks of them keeps its width and thickness (see the list below). The stucco/mortar adheres on the surface of 1 block.

### Metal objects

1 lower half of the seating Buddha image, which is gilded with gold leaf partially, was unearthed (TP12-M1a to c). A small precious stone (ruby?) is set in its side. The surface including the broken section of this image is covered with blackish lacquer(?). This fact suggests that this broken image had still been a object for worship for some time after its upper half was disappeared.

65 fragments of the plinth for the Buddha image were unearthed (TP12-M2 to M66, though some of them may be fragments of Buddha image itself). The broken state of these fragments shows its artificial destruction. 1 big fragment of them is caked with many shards of roof tiles. It is unidentified that these fragments are from how many plinths, because any existent plinths which have the same series of ornaments were not found during this mission. A fragment TP12-M2 especially has a rare ornament.

Furthermore, 5 fragments from 3 Buddha images (TP12-M67 to M71), 1 rusted cut nail, 5 small pieces of melted slugs (2 of them include the shards of roof tiles), 21 small unidentified fragments, and 5 tools or fittings were also unearthed.

### Stucco/Mortar

97 blocks of stucco/mortar were unearthed. 11 of them are parts of the moldings or ornaments (TP12-C1~ C11). 12 blocks include the fragments of bricks or shards of roof tiles. 9 blocks have the traces of laths (TP12-C12~ C20).

### Architectural ornaments

4 pieces of stoneware fragments, which are probably a kind of the decorations of the ridge (crest) or decorations of the gableboard of temple architecture like sim, were unearthed (TP12-A1 to A4).

Almost all of those ornaments in existence are made of mortar, but there is rare example of ceramic on the ridge of sim at Vat Si Saket (photo at the facing page).

### Stoneware

There are relatively small amount of ceramics unearthed at Test Pit 12.

Width	Thickness	Remarks
120	5	a part of front end
128	5	a part of rear end with stopper
128	6	a part of rear end with stopper
131	12	a part of front end of eaves-end tile

Measurements of roof tiles from TP12 (mm)

Width	Thickness
103	40
105	40
107	44
107	50
112	44
112	44
115	50
116	38
120	43
120	52
121	50
121	53
127	60
130	45
137	67

Measurements of bricks from TP12 (mm)



Stoneware shards counts 43 in total. They are classified with each number of pieces as follows;

Bowl type wares: six pieces (five shards of body part and one shard of rim part)

Mortar type wares: six pieces (five shards of body part and one shard of base part)

Jar type wares: 27 pieces (20 shards of body part, six shards of base part and one shard of rim part)

Oil lamp: one piece of base part, which three shards were attached with each other.

Smoking pipe: one piece

TP12-S1 is a body part of smoking pipe. It sizes 1.15cm in exterior diameter at the joint point of body and stem. The paste is relatively fine and solid. Its colour varied from dark gray to grayish white because of uneven and under firing. Generally speaking, however, its similarity to and association with other stonewares from the excavation shows that they were made of a similar clay and fired in the same kiln conditions. There is a draw hole intersected throughout the remained part from the stem side to the neck side. There is also remained a lug part which has no hole, while other specimens usually have a hole for taking a suspension string. The exterior was decorated by molding. Its design is not clear, but probably consists of bird and some other geometric motives.

#### Imported ceramics

Imported ceramics counts eleven pieces in total. All the findings are small fragments and there is no significant specimen to be reported individually. They are classified as follows;

Chinese underglazed blue and white: four pieces of bowls, two of which are relatively newer products after 19th century.

Celadon glazed stoneware: two pieces of large plates probably manufactured in Thai.

Brown glazed stoneware: one piece of large jar probably manufactured in Thai.

Vietnamese underglazed blue and white: one piece of bowl.

Glazed pottery: three pieces of bowls or plates, which texture are not porcelain or stoneware. There is no decoration existed on their remained parts. Two shards of them have relatively fine and solid paste and transparent glaze with many cracks occurred in it. Another one specimen has coarse and crumble paste. Its glaze is grayish milky white and completely opaque. It is unidentified about their origin (production kilns) or dating.

#### Earthenware

There are only ten pieces of earthenware recovered at the Test Pit 12. All the shards are small fragments. The shapes of rim parts counting five pieces have common proportion with other findings from different Test Pit s. There is no significant specimen to be reported with photos.

#### Stone tools

A piece of fragment of probable Schist stone stele (TP12-T1) and a sandstone fragment with some kind of paint coat on one side was found.



Ceramic ridge ornaments at Vat Si Saket



TP12-A1 ~ A4



TP12-S1

10cm



TP12-C1 ~ C11

10cm





TP12-C12 ~ C20

10cm



TP12-M1

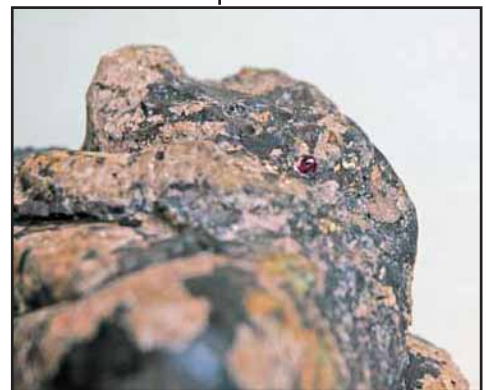

10cm





10cm



5cm





TP12-M22 ~ M38

10cm



TP12-M39 ~ M46

10cm





TP12-M47 ~ M66



TP12-M67 ~ M71



TP12-R1



TP12-R2



TP12-R3, R4



TP12-R5



TP12-T1



TP12-T2





# TEST PIT 13

Location: Near Samsenthai Road/Langsan Avenue junction

Excavation Date: July 23, 2004

Identified Working Infrastructure(s): None

Identified Archaeological Feature(s): None.

Recovered Artifacts: 223

Stoneware: 55, Earthenware: 48, Imported ceramics: 19, Stone: 11,

Brick: 12, Metal Object: 2, Stucco/Mortar: 1, Roof Tile: 23, Bone: 50

Note: Numerous faunal remains were found.

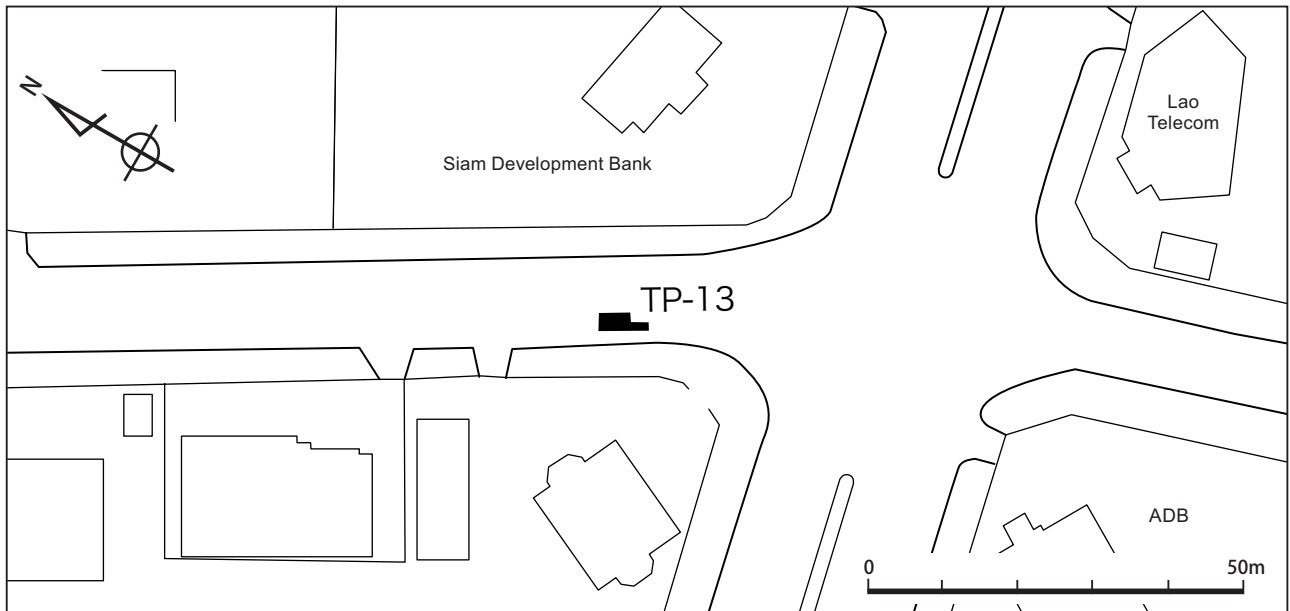
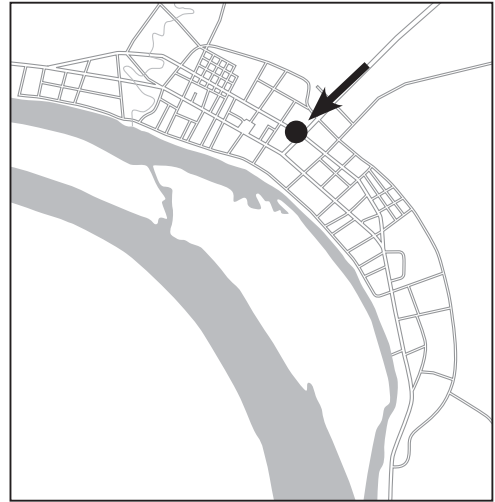

**Point E13-26**  
Coordinates:  
X=87,909.729  
Y=47,066.104  
EL=168.87m

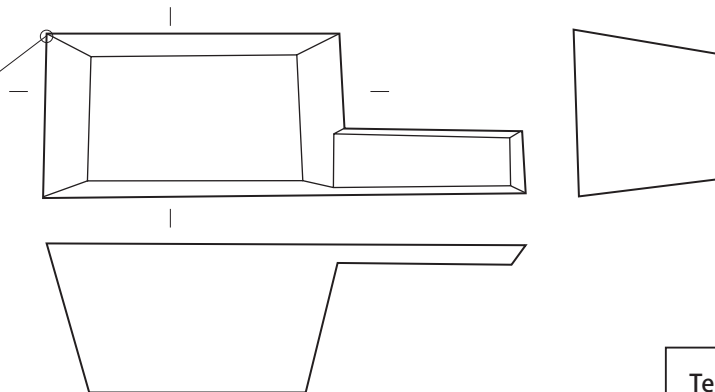

### Test Pit Dimention (max.)

Length: 4.03m

Width: 2.21m

Depth: 2.01m

Surface Area: 8.90m<sup>2</sup>



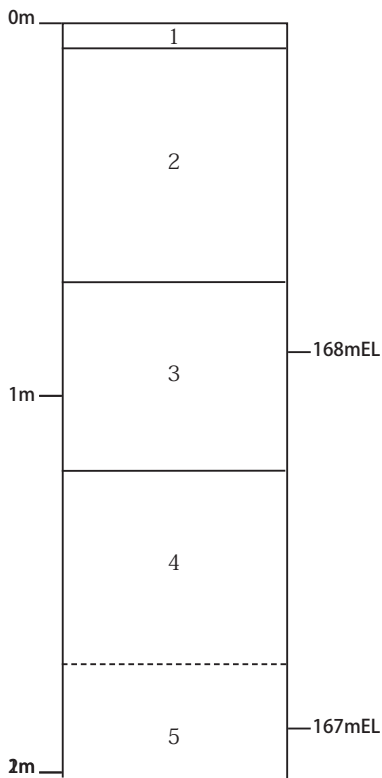

**Explanation of Soil Layers**

- 1 Asphalt: Present road surface.
- 2 Pebble/Laterite soil: The sub-base layer for the present road surface.
- 3 Dark grey silty clay. Artifacts found from this layer.
- 4 Light yellow grey silty clay: Uniform and with no inclusion.
- 5 Light grey clay: Uniform and with no inclusion.



**Artifacts**

**Roof tiles**

A total of 23 shards of thin flat roof tiles was unearthed.

**Bricks**

One piece of brick, which keeps the original length, width, and thickness, and 11 broken blocks were unearthed. Each of 4 blocks of them keeps its width and thickness only (see the list below).

Length	Width	Thickness
182	91	46
	105	66
	130	61
	152	60
	180	88

**Metal objects**

A small piece of melted slug, and 1 small fragment of plate were unearthed.

**Stucco/Mortar**

A block of stucco was unearthed.

**Measurements of bricks from TP13 (mm)**



**View of the excavated area**



**Excavation in progress**

## Earthenware

There are 48 pieces of earthenware recovered at the Test Pit 13, that is not including a complete form. The shapes of rim parts counting ten pieces have also common proportions with others such as the findings from TP11. However one specimen of rim part exists unusual surface, which seems to be coated with black (sumac?) lacquer, as shown in the photo plate. There are also recovered three pieces of jar typed wares with characteristic impressed decorations.

## Stoneware

There are relatively small amount of ceramics unearthed at Test Pit 13.

Stoneware shards counts 55 pieces in total. They vary in shape classes and texture, for instance some glazed specimens are included. They are classified with each number of pieces as follows; bowl type wares: seven pieces (one shard of base part, three shards of body part and two shards of rim part), mortar type wares: eight pieces (five shards of body parts and two shards of base parts), jar type wares: 38 pieces (32 shards of body part, four shards of base part and two shards of rim part), oil lamp: two pieces (one shard of base saucer part and one shard of central post part), knob or something other object: one piece.

TP13-S1 is a base part of large jar. Its estimated size measures around 16cm in outer diameter of the bottom end. The average of thickness at the base measures 7.5 mm. Its paste is light greyish coloured, slightly coarse but solid. Most of the stoneware made in local usually have the evident striations or code-cut marks on their exterior bottoms, which were caused by the twist cord used to cut the wares from the wheel. The specimen, however, remains no trace of striations. This bottom is almost flat, smooth and seems to be shaved or leveled by wooden spatula or some tools. The lower wall is also carved to make vertical wide grooves and there is glazed on its exterior surface of the wall. The glaze is greyish white, opaque and not shiny. It may be ash glaze which could not present its normal colour, transparency or shine since the specimen was under-fired. There are not so many but considerable numbers of the glazed stoneware shards as similar to this specimen recovered at the excavation of other test pits.

TP13-S2 is a knob shaped object of stoneware. It sizes 3.3cm in diameter at the top end. The paste is dark greyish coloured, slightly coarse but solid. The texture may be common with other stoneware products made in local. The specimen was probably wheel made and its appearance looks like a knob on lid. The usual knobs on lids, however, should be spindle or mushroom shaped, while the profile of specimen is trapezoid or its top end is flat and wider than the body part. There is a possibility that the specimen is not a part of knob but some other kinds of objects such as chess piece which has been recovered at the excavation and investigation of the other kiln site at Sisattanack in Vientiane, according to the report \*(See the Reference).

TP13-S3 and TP13-S4 are parts of the oil lamp (S3 is a saucer part of the base and S4 is a central post part). These two shards are not adjoined with each other, however, both specimens are probably to be one same object, because their texture of paste are completely same as far as recognized by the naked eye. Its estimated size measures 5.4cm in outer diameter of at the base. The height of central post measures 9.1cm, which may be higher than usual size, however there is no hole for raising and supporting wicks at the top. The paste is quite fine grained and solid, including no sand particle. Its colour varies between black, dark grey, light grey and light greyish beige for uneven or under firing.

## Imported ceramics

Imported ceramics unearthed from TP013 count 19 pieces in total. The major items of findings are underglazed blue and white porcelain manufactured in China and also Vietnam. Their detailed classification with numbers are as follows; Chinese underglazed blue and white wares: five pieces of bowls (four shards of base part and one piece of body part), Chinese white porcelain: two pieces of a bowl (two shards of rim part), Chinese overglazed enamel painted porcelain: one piece of bowl (its rim part), Celadon glazed stoneware probably made in Thai: one piece of body part of a bowl, Vietnamese underglazed blue and white ware in 16th to the early 17th centuries: eight pieces of bowls (two shards of rim, five shards of body and one shard of base part) and one piece of a small bottle (its body part), and Vietnamese overglazed enamel painted ware: one piece of body part of a bowl (which enamel decoration has been actually faded out).

TP13-I1 is a base part of underglazed blue and white bowl. Its estimated size measures 8.6cm in diameter of outer

circulate of foot ring. The specimen is relatively large sized bowl with tall foot ring. Its paste is slightly greyish white coloured, fine and solid, while including many small black particles. Underglazed decoration of several horizontal lines and some other motives are painted on the exterior in greyish blue colour. The glaze is pale white, almost transparent and shiny. There is no glaze on the interior bottom and the bottom end of foot ring, while the exterior bottom inside of the foot ring is glazed completely. Those non-glazed areas occurs light reddish brown colour that is due to iron oxide in the paste clay. There are sand grains or some other substances attached on the inner wall of foot ring during firing. The specimen was probably manufacture in some kiln of Jindezhen or in Guangdong province of Southern China during early Qing dynasty.

TP13-I2 is a rim part of Chinese white porcelain, which consists of two sherds adjoined with each other. The specimen has rather thin body and its estimated size measures 10.6cm in diameter of top end of the rim. The paste is greyish white, very fine and solid. The glaze is greyish pale white, uneven and opaque. There is no decoration. The glaze on the top end of the rim is wiped off. Its production kiln may belong to Jindezhen kilns group. The date is not clarified, but it seems to be comparatively older type, so called bluish white porcelain or Qing-bai (Qing-pai) ware during 13th to 14th centuries, so far as observing its glaze and shape.

Stone tools

A piece of shale stele, polished on one side with linear incision, measuring 109 x 102 x 13mm and weighing 250 grams was found. Also a piece of sandstone grinding stone, polished on one side, measuring 128 x 41 x 31 and weighing 212 grams was recovered.



TP13-T1



TP13-T2



Earthenware from TP13





Ceramic pieces from TP13

10cm



# TEST PIT 14

Location: Near Kua Lao Restaurant.

Excavation Date: July 26, 2004

Identified Working Infrastructure(s): None

Identified Archaeological Feature(s): None

Recovered Artifacts: 37

Stoneware: 13, Earthenware: 6, Imported ceramics: 5, Brick: 4,

Metal Object: 7, Bone: 2

Note:

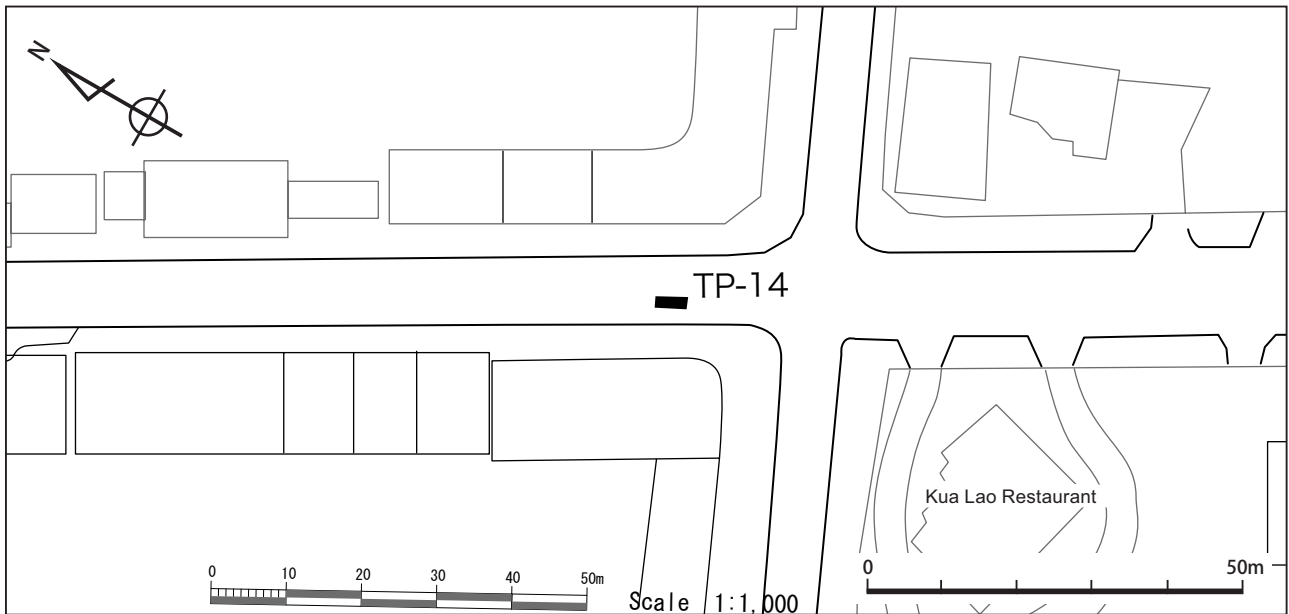
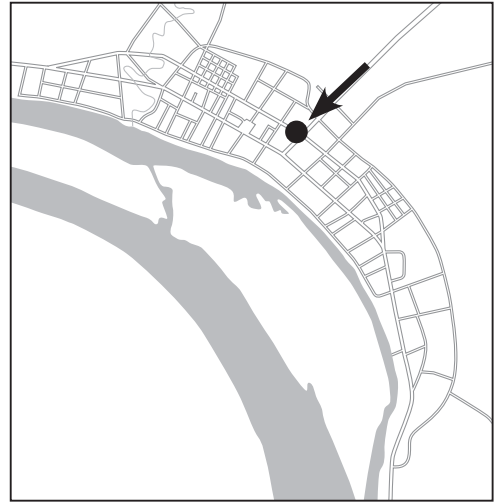

**Point E14-13**  
Coordinates:  
X=87,987.164  
Y=46,924.366  
EL=169.11m

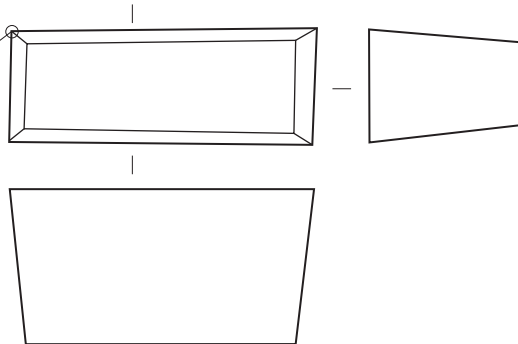

### Test Pit Dimention (max.)

Length: 4.09m

Width: 1.55m

Depth: 2.06m

Surface Area: 6.34m<sup>2</sup>

Cubic content: 10.3m<sup>3</sup>

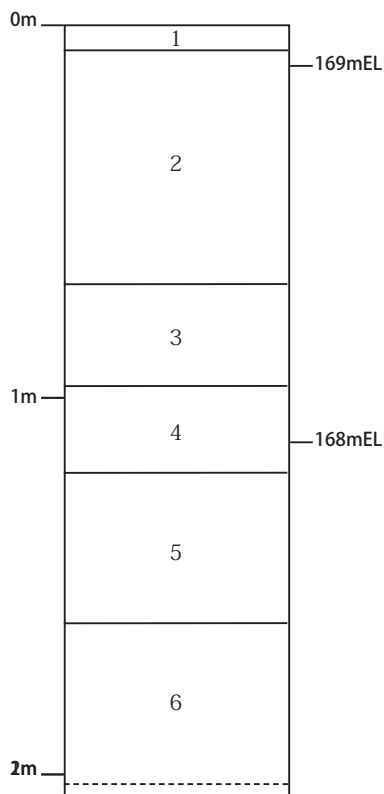

**Explanation of Soil Layers**

- 1 Asphalt: Present road surface.
- 2 Pebble/Laterite soil: The sub-base layer for the present road surface.
- 3 Light brown sand. Probably the sub-base layer for the present road surface.
- 4 Dark grey silty clay. Artifacts found from this layer.
- 5 Light yellow grey silty clay: Uniform and with no inclusion.
- 6 Light grey clay: Uniform and with no inclusion.



**Artifacts**

**Bricks**

Four broken blocks of bricks were unearthed. Each of 2 blocks of them keeps its width and thickness (see the list below).

Width	Thickness
121	46
121	55

Measurements of bricks from TP14 (mm)

**Metal objects**

Seven pieces of leads of dry cells were unearthed.

**Stoneware**

There are quite small amount of ceramics unearthed at Test Pit 14. The findings, however includes some significant specimens.

Stoneware shards counts 19 pieces in total. They are classified with each number of pieces as follows; mortar type wares: five pieces (two shards of base part, two shards of body part and one shard of rim part), bowl with grater: one piece of rim to body part, jar type wares: six pieces (five shards of body part, one shard of base part) Smoking pipe: one piece of stem part



Excavation in progress



Excavation in progress

TP14-S1 is a rim to body part of small bowl with grater on the interior. Its estimated rim size measures 16.8cm at top end of the outer rim. The paste is dark gray or almost black coloured, quite solid but coarse. There are incised decoration of narrow horizontal lines in 3-4 mm pitch and several vertical lines to make grating face. The same type wares with graters are also found at the kiln site where TP02 was located, it could be understood as a kind of stonewares made in local. As mentioned before, it is generally understood that these typed wares have been basically used for grinding or braying foods as a kind of cooking tool. This specimen, however, has not so sharp edged teeth that it is unlikely serviceable or useful for processing foods. Furthermore, the surface on grating part of the specimen does not seem to be worn out or used well at all. It is, therefore, still unclear about the actual usage of these typed wares.

TP14-S2 is a stem part of smoking pipe. The specimen exists the almost full stem and body part. The decorated rib with a hole is attached to its body part. The average size measures 1.55cm in exterior diameter of the stem. The remained part is slightly tapered, that is, the end of stem is a little bit wider than its main body part. The paste is relatively fine and solid. Its colour varied from gray to light grayish white because of uneven and under firing. As same as other smoking pipes discovered from other test pits, its texture is common to other stoneware made in local kilns. There is a draw hole intersected throughout the remained part. The exterior of the body to rib part is decorated by molding. Its design is not clear, but probably consists of vine-like or scroll motives. The specimen shows relatively typical shape and design as a local made pipe, which varied examples are confirmed at findings from other test pits and also the other excavations and investigations of the Sisattanak kiln site.

#### Imported ceramics

Imported ceramics unearthed at TP014 count only 5 pieces. They consist of; Chinese underglazed blue and white wares: one piece of bowl (rim part) and one piece of plate (rim part), brown glazed stoneware probably made in Thai: one piece of small bottle, Vietnamese underglazed blue and white ware: one piece of bowl (body part), and Vietnamese overglazed enamel painted ware: one piece of bowl (rim part)

TP14-I1 is a rim part of underglazed blue and white plate. Its size is estimated to be around 32cm in diameter at top end of the everted rim. The paste is light greyish white, slightly coarse for the texture of porcelain, but solid. The decoration of flower motif is painted in dark blue colour. The glaze is pale white, almost opaque with many bubbles and cracks occurred in it. The glaze surface loses its shine. According to its characteristic shape of rim and the decoration, the specimen may be regarded as a kind of so-called "Kraak-type" wares which were manufactured in large quantities at the Jindezhen kiln groups in Jiangxi Province of China and exported widely to all over the Asia and also to Europe by the Dutch East India Company, during the late 16th to middle 17th centuries. These Kraak-type wares were also recovered at many coastal sites and from ship-wrecks in Southeast Asia. Therefore, it is supposed that Vientiane area in that period should be some scaled commercial center rather than a small village.

TP14-I2 is a small jar or bottle of glazed stoneware. There is remained bottom to body part with a small lug in vertical direction. It sizes 5.2cm in diameter at the bottom. The exterior bottom is almost flat and there is remained the cord-cut marks which are almost straight and parallel, indicating a cut made while the potter's wheel was almost stationary. Its paste is brownish dark grey coloured, coarse but rather solid. The glaze which probably contains iron shows light purplish brown coloured, it does not cover the exterior sufficiently, but exists in mottle. There is no decoration remained except for the small vertical lug. It is difficult to identify its origin. The texture of paste and its proportion is apparently different from Chinese products. Simply considering, it might be manufactured at some kiln in Thai, while its shape should be rare in Thai's stoneware. On the other hand, the texture of its paste and glaze should be quite similar to Khmer ceramics. At the moment, there is no clear evidence that these iron-glazed stoneware were made in local, however some types of local made stoneware have similar proportion and texture of paste to this specimen. It is not impossible to assume that these typed stoneware with iron glaze were also fired in Lao local.

#### Earthenware

There are very few, only six pieces of earthenware recovered at the Test Pit 14. All the shards are small fragments, while two shards with the impressed decorations of a series of short oblique lines or herringbone-like motifs were included, as shown in the photo plate.





TP14-S1



TP14-S3



TP14-I1



TP14-S2



TP14-I1

# TEST PIT 15

Location: Near National Museum.

Excavation Date: July 22, 2004

Identified Working Infrastructure(s): None

Identified Archaeological Feature(s): Alignment of bricks

Identified Artifacts: 529

Stoneware: 116, Earthenware: 29, Imported ceramics: 10, Stone: 1,

Brick: 54, Laterite Block: 1, Stucco/Mortar: 9, Roof Tile: 179

Note: Within the range of presently non-existent Vat Sisumon.

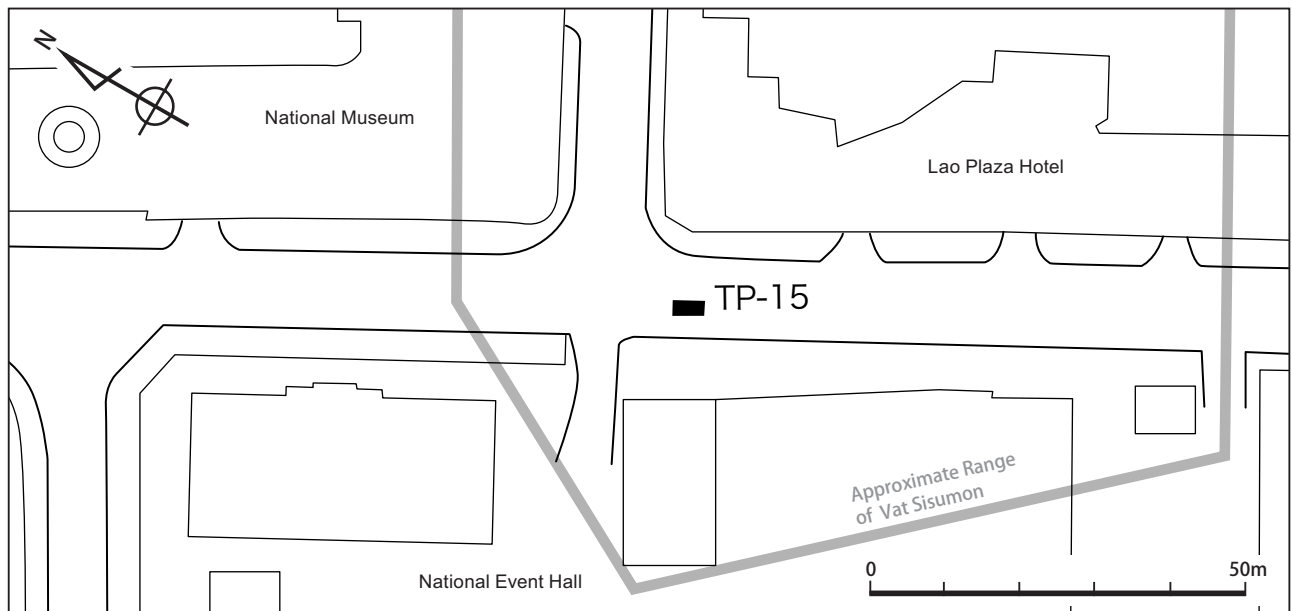
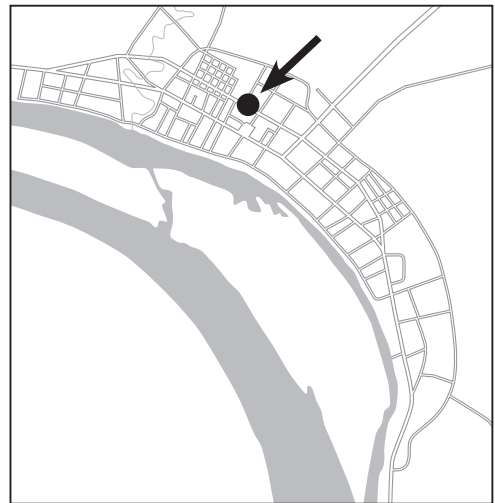

**Point E15-16**  
Coordinates:  
X=88,122.200  
Y=46,674.287  
EL=169.35m

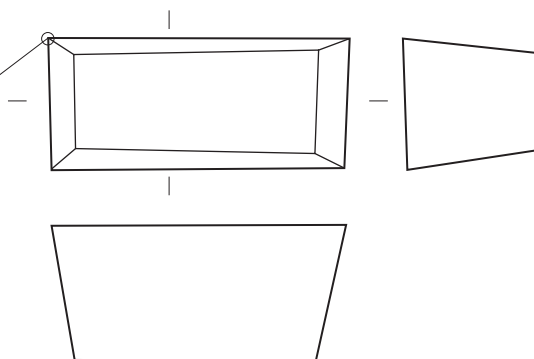

### Test Pit Dimention (max.)

Length: 4.00m

Width: 1.77m

Depth: 1.80m

Surface Area: 7.08m<sup>2</sup>

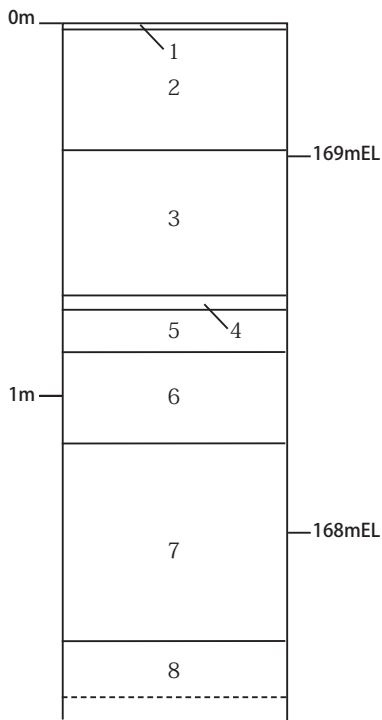

Explanation of Soil Layers	
1	Asphalt: Present road surface.
2	Pebble/Laterite soil: The sub-base layer for the present road surface.
3	Solid layer of bricks. Pavement during the colonial era?
4	Light brown sand. Probably the sub-base layer for the upper pavement.
5	Dark grey silt layer. Probably the sub-base layer for the earlier road surface.
6	Dark grey silty clay. Artifacts found from this layer.
7	Grey silty clay: Uniform and with no inclusion.
8	Grey clay: Uniform and with no inclusion.



**General**

Some of unearthed artifacts from this trench may have a relation to Vat Si Sumon that had been located around here until beginning of 20th century.

**Structures**

A bricks line(?) was detected along the south wall of this trench (about 80 cm in depth, TP15-ST1). It was not unidentified that this was a part of structure or not, because not only its construction technique was very poor but the rest part may be continue to outside of trench area.

Almost of these bricks were picked up for further excavation.

**Artifacts**

**Roof tiles**

179 shards of thin flat roof tiles were unearthed. 1 shard keeps its full width (see the list below, TP15-R1).



Old brick pavement



Alignment of bricks



## Bricks

2 pieces of bricks, each of which keeps its original length, width, and thickness, and 52 broken blocks were unearthed. Each of 18 blocks of them keeps its width and thickness only (see the list below).

## Stucco/Mortar

9 blocks of stucco/mortar were unearthed. 1 block of them in the shape of a cylinder includes many shards of roof tiles.

## Stoneware

There are comparatively many shards of ceramics recovered at Test Pit 15. Stoneware shards counts 116 pieces in total. The findings mainly consists of fragments of jars. They are classified with each number of pieces as follows; mortar type wares: five pieces (two shards of rim part and three shards of body part), bowl type wares: two pieces (one shard of rim part and one shard of body part), jar type wares: 106 pieces (97 shards of body part and nine shards of base part), smoking pipe: one piece of stem part, lid for jar(?): one piece

Ash glazed ware: one piece of bowl (body part) probably made in local

TP15-S1 is a body part of disk shaped ware which may be classified as a kind of lid or cover. It is impossible to confirm about that the specimen associates with what kind of object. Generally speaking, however, its parent ware should be a kind of pot or jar. There might be a knob at the center which part is not actually remained. Its size is estimated 10.6cm in diameter at the rim of disk. Its bottom is flat

and there are clearly remained the code-cut marks which lines are straight and parallel indicating a cut made while the potter's wheel was stationary. The upper surface is almost flat or barely swells at its central part. The thickness measures 6.5~7.0mm in average. The paste is light grayish coloured, rather fine grained and solid. On the upper surface, there are incised or pricked decorations of small circular motives consisting of five tiny dots.

## Imported ceramics

Imported ceramics unearthed from TP015 count 10 pieces in total, which is rather small amount in comparison with the amount of stoneware findings. They are classified as follows; Chinese underglazed blue and white wares: six pieces of bowls (four shards of body part and two pieces of rim part), Thai's Celadon glazed stoneware: two pieces of bowl (one shard of body and one shard of rim part), Thai's underglaze iron painted ware: one piece of bowl (base part), Vietnamese underglazed blue and white ware: one piece of bowl (body part)

TP15-I1 is a rim part of Chinese underglazed blue and white bowl. Five shards belong to the same one specimen. Its size is estimated 11.8cm in diameter at top end of the rim. The paste is nearly white coloured, very fine and solid. On the exterior rim, there is underglaze decoration painted in light greyish blue, which design is combined motives of circles, dots and horizontal lines. The glaze is light greyish pale white, opaque with many small bubbles. There are also many pin-holes on the surface of glaze, and its shine is dull. The glaze at top end of the interior rim is wiped off. From these characteristics of paste, glaze and decor it can be identified that the specimen was probably manufactured in Southern China during 16th to 17th centuries.

TP15-I2 is a base part of bowl with underglaze iron decoration. The specimen has a small foot-ring of 4mm in height, which was shaped by shaving body on the wheel. Its estimated size of the bowl measures 7.6cm in diameter at outer bottom end of the foot-ring. The paste is light yellowish beige colour, slightly coarse but solid. There is no slip observed under the glaze. The iron-paint decoration of horizontal circular motif in greenish black coloured are remained on the exterior and interior base.

Width	Thickness	Remarks
133	6	A part of rear end with stopper

Measurements of roof tile from TP15 (mm)

Length	Width	Thickness	Remarks
	95	38	
207	100	38	
	100	40	
	102	57	
	104	46	
	105	45	
	105	45	
	106	48	
	107	52	
214	108	50	Mortar adheres
	110	45	
	110	47	
	110	51	
	110	56	
	112	42	
	117	37	
	118	50	
	122	43	
	122	64	
	126	45	

Measurements of bricks from TP15 (mm)

The glaze is greyish pale coloured. It is quite thin layered and transparent, while many fine cracks and bubbles occurred in it. The specimen is identified to be Thai made ware dating 15th to middle of 16th centuries, which production kiln might be in Kalong of Northern Thai or in Sukhothai and Sawankhalok kiln groups in Central Thai.

**Earthenware**

There are 29 pieces of earthenware recovered at the Test Pit 15. Among the findings, one specimen which may be a rim part of bowl typed ware has outward angled rim, that rim shape is different from other rims of jar typed wares. Only its surface presents black colour, while the inside is dark reddish brown as shown in photo plate. Another one piece of base part on the photo plate have rather finer grained paste than other general earthenware. The specimen should be a base part of jar or bottle typed ware and dated in comparatively newer period.

Except for jar and/or bowl typed vessels, there is unearthed one piece of spindle shaped lump of clay with hole along the axis as shown in photo plate. Its sizes measure 6.3cm in length, 1.4~1.6cm in diameter of the hole and 5.5cm in outer diameter at the central part. The specimen was made by not potter' s wheel but hand, and it is understood or assumed to be used as weight for fish-net, which same shaped objects of stoneware are also discovered at several Test Pit s.



TP15-R1



TP15-S1



TP15-I1

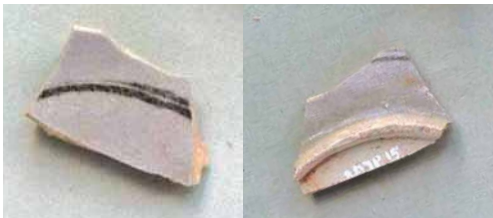

TP15-I2



Earthenware from TP15

# TEST PIT 16

Location: Between Touran/Samsenthai junction and  
Hai Phong/Samsenthai Junction.

Excavation Date: July 29, 2004

Identified Working Infrastructure(s):

Identified Archaeological Feature(s): None

Recovered Artifacts: 107

Stoneware: 23, Earthenware: 22, Imported ceramics: 10, Glass: 1,

Stone: 2, Brick: 31, Stucco/Mortar: 3, Roof Tile: 11, Bone: 4

Note:

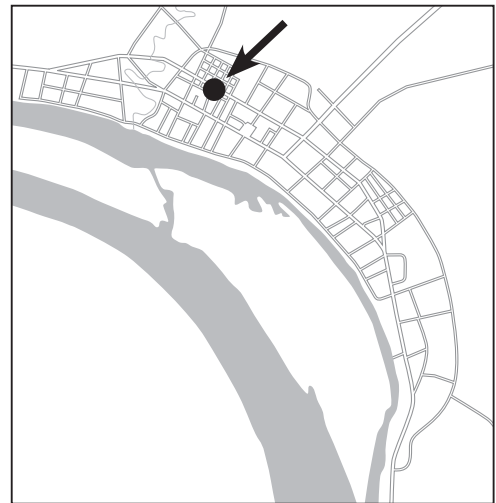

**Point E16-7**  
Coordinates:  
X=88,262.578  
Y=46,412.745  
EL=169.65m

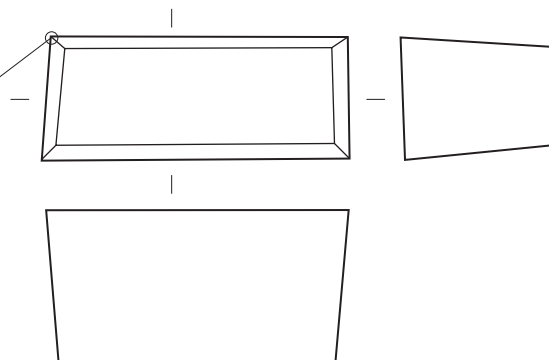

Test Pit Dimention (max.)
Length: 4.13m
Width: 1.68m
Depth: 2.05m
Surface Area: 6.94m <sup>2</sup>



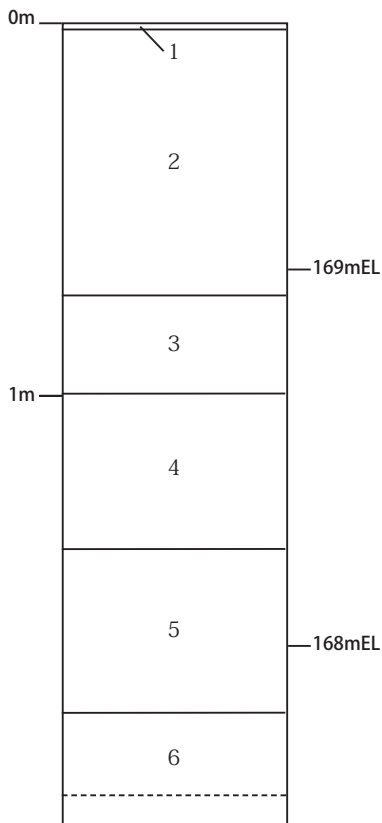

**Explanation of Soil Layers**

- 1 Asphalt: Present road surface.
- 2 Pebble/Laterite soil: The sub-base layer for the present road surface.
- 3 Dark grey silt layer with brokenpieces of concrete, bricks and srones. Probably the sub-base layer for the earlier road surface.
- 4 Dark grey silty clay. Artifacts found from this layer.
- 5 Grey silty clay: Uniform and with no inclusion.
- 6 Grey clay: Uniform and with no inclusion.



**Artifacts**

**Roof tiles**

11 shards of thin flat roof tiles were unearthed.

**Bricks**

31 broken blocks of bricks were unearthed. Each of 2 blocks of them keeps its width and thickness (see the list below).

Width	Thickness
110	55
143	58

Measurments of bricks from TP16 (mm)

**Laterite**

1 small block of laterite was unearthed. The artificial process is not observable.



Excavation in progress



Excavation in progress

## Stucco/Mortar

3 blocks of stucco/mortar were unearthed.

## Stoneware

There are relatively small amount of ceramics unearthed at Test Pit 16.

Stoneware shards counts 23 pieces in total. Most of them are fragmentary and worn-out. There is no significant specimen to be reported individually. The findings are classified with each number of pieces as follows; Bowl type wares: two pieces (one shard of body part and one shard of rim part), Mortar type wares: two pieces (one shard of body part and one shard of rim part), Jar type wares: 18 pieces (15 shards of body part and three shards of base part), Small bowl with grater: one piece of body part.

## Imported ceramics

Imported ceramics unearthed from TP16 count ten pieces in total. The specimens include Chinese modern products in 19th to 20th centuries. Their classification with numbers are as follows; Chinese underglazed blue and white wares: four pieces of bowls (two shards of body part and two shards of rim part), Chinese white porcelain: one piece of spoon (stem part), Chinese overglazed enamel painted porcelain: one piece of bowl (bottom part), which decoration has been actually faded out., Vietnamese underglazed blue and white ware: one piece of bowl (body part), Japanese underglazed blue and white porcelain: one piece of bowl (body part) and one piece of lid shaped ware (body part)

TP16-I1 is a body part of underglazed blue and white bowl, which two fragments were attached with each other. Its paste is light grey coloured, solid but rather coarse as a Chinese porcelain. There is underglaze decoration of the Xuan-xi (Double Happiness in Chinese characters deformed for decorative design) and floral scroll motives are painted on the exterior in dark blue colour. The glaze is pale greyish white, shiny but opaque with many cracks and bubbles inside. The specimen can be identified to be fired at Dehua (Te-hua) kiln in Fujien (Fukien) province of Southern China in later Qing period, probably during 19th to 20th centuries.

TP16-I2 is a shard of Chinese white porcelain, which may be a stem part of the spoon for Chinese dish. There is no decoration on the remained part. The paste is nearly pure white, very fine and solid. Its glaze is pale white, transparent and the surface shines well. The specimen was probably manufactured in Jindezhen kiln groups during Qing dynasty, around 18th to 19th centuries or the later period.

TP16-I3 is a body part of lid-shaped ware with underglazed blue and white decoration. It can not be confirmed about its whole shape and the parent pot which the lid should associate with. Generally considering, however, the specimen is supposed to cover a kind of urn or deep bowl with wide mouth. The paste is greyish white, solid but slightly coarse, including some black particles. The underglaze decoration of dotted flower scroll motives was not painted but printed (transferred) by copper-board. The colour of decoration presents vivid blue which was effected from cobalt. The glaze is pale coloured transparent and shines well. As the specimen has peculiar technique of decoration and characteristics of paste and used pigment, it is possible that the specimen was manufactured in Seto-mino kiln groups in Central Japan between the latter 19th century and the early 20th century.

## Earthenware

There are 22 pieces of earthenware recovered at the Test Pit 16. All the shards are small fragments and worn-out. There is no significant specimen to be reported individually with photos.



TP02-I1



TP02-I2



TP02-I3

# TEST PIT 17

Location: Near Khoun Boulom/Samsenthai Junction

Excavation Date: July 30, 2004.

Identified Working Infrastructure(s): None.

Identified Archaeological Feature(s): None.

Identified Artifacts: 287

Stoneware: 97, Earthenware: 82, Imported ceramics: 39, Bone: 30,

Glass: 5, Stone: 2, Brick: 24, Wooden Object: 2, Roof Tile: 8

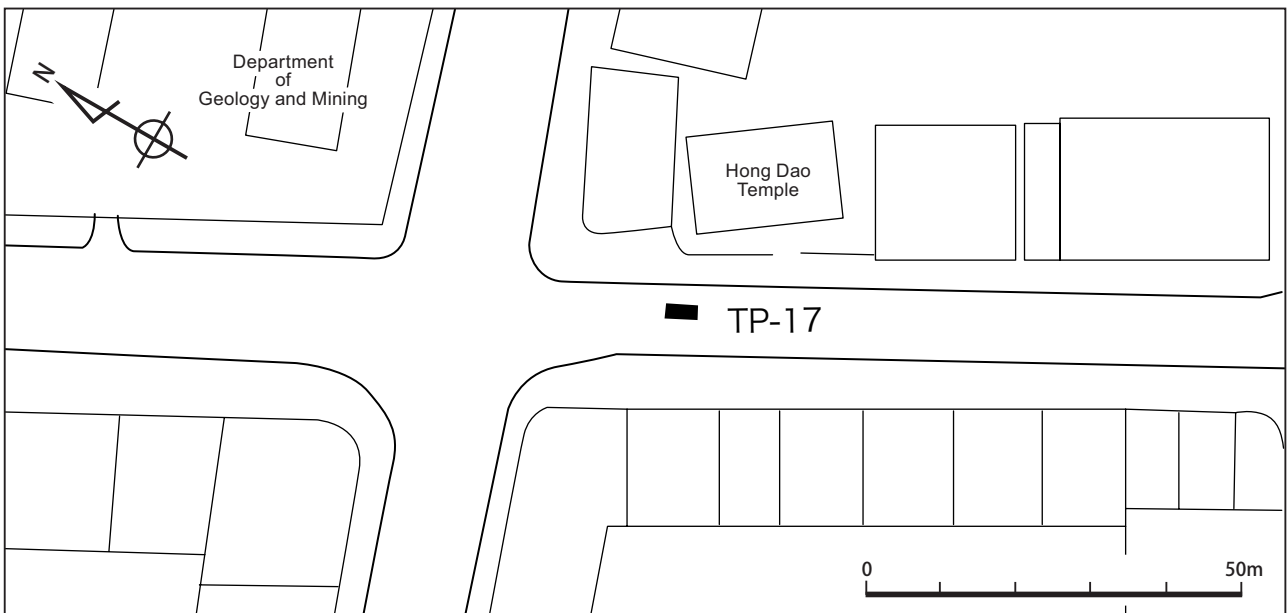
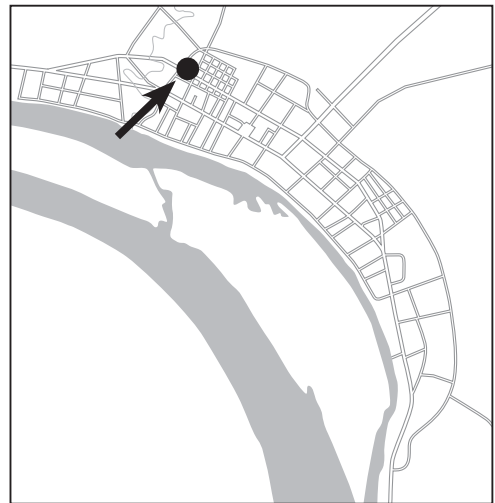

**Point E17-14**  
Coordinates:  
X=88,369.333  
Y=46,213.836  
EL=170.28m

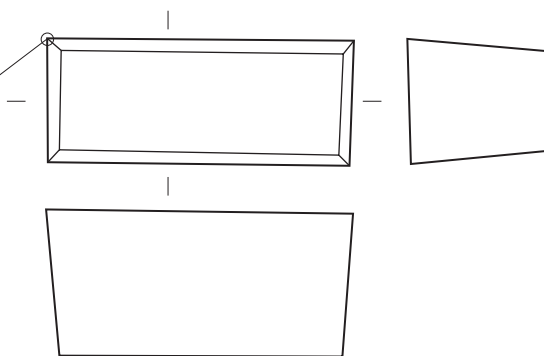

### Test Pit Dimention (max.)

Length: 4.09m

Width: 1.72m

Depth: 1.96m

Surface Area: 7.03m<sup>2</sup>



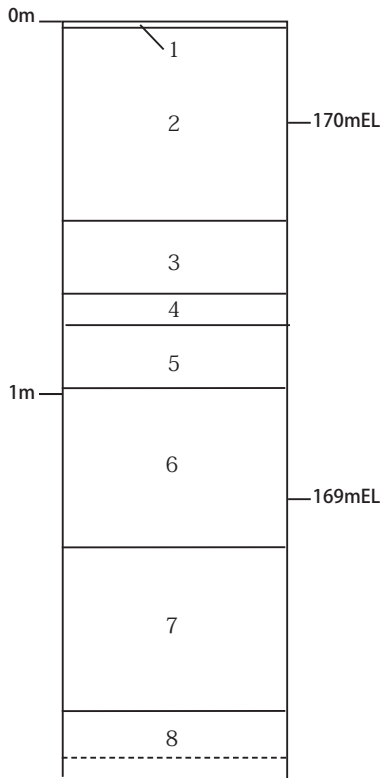

Explanation of Soil Layers	
1	Asphalt: Present road surface.
2	Pebble/Laterite soil: The sub-base layer for the present road surface.
3	Dark grey silt layer with brokenpieces of concrete, bricks and srones. Probably the sub-base layer for the earlier road surface.
4	Pebble/Laterite soil: The sub-base layer for the present road surface.
5	Dark grey silt layer with brokenpieces of concrete, bricks and srones. Probably the sub-base layer for the earlier road surface.
6	Dark grey silty clay. Artifacts found from this layer.
7	Grey silty clay: Uniform and with no inclusion.
8	Grey clay: Uniform and with no inclusion.



## Artifacts

### Roof tiles

Eight shards of thin flat roof tiles were unearthed.

### Bricks

23 broken blocks of bricks were unearthed. Only 1 block of them keep its width and thickness (see the list below), and stucco/mortar adheres on the surface of another 1 block. 1 broken thin block (approximately 20 mm of the thickness) of floor tile (?) was also unearthed.

Width	Thickness
100	41

Measurments of bricks from TP16 (mm)

### Wooden objects

A broken part of decayed timber and an artificial part in the shape of triangle were unearthed.



Excavation in progress



Excavation in progress

## Stoneware

From the excavation at the test pit 17, considerable amounts of ceramics were recovered. The stoneware shards count 97 pieces in total, which displayed quite wide variations in typologies of shape classes and their texture or manufacture also. Their major contents of typology are almost common to the findings from other test pits.

The specimens are classified and counted in each shape class as follows:

Mortar or large bowl type wares: 13 pieces (three pieces of outward angled rim, eight pieces of body and two pieces of base),

Bowl with grating surface on the interior: one piece with almost complete form (three shards were adjoined with each other and made one piece of ware),

Jar type wares: 80 pieces (five pieces of base part, 66 pieces of body part and nine pieces of rim part),

Smoking pipe: one piece of the upper bowl part

Among these findings, on the other hand, there are included quite many shards presenting greyish white coloured paste which should be the results of ill-firing, while some other shards had a dark green to black colored natural glaze effect on some surfaces, from fly-ash deposited during firing.

TP17-S1 is a bowl with grater on the interior, existing almost complete form. Its sizes are measured as follows: 16.2cm in diameter at top end of the exterior rim, 6.8cm in diameter at the exterior bottom and 6.5cm in full height. The paste is dark greyish coloured, slightly coarse but solid. Its surface presents even dark grey colour, partially shine with natural fly-ash. The specimen seems to be fired well under the proper condition of temperature and reduction atmosphere in the kiln. There are grating surface extended almost all over the interior surface. The "graters" were made by incising horizontal and concentric circles in 2~5mm pitch while the bowl was still on the wheel. The concentric lines were first cut, then the vertical and radial lines were incised from the bottom upwards by hand (which order is apparent from the direction of trail and the situation of overlapping lines). The same type wares with graters are also found at the kiln site where TP02 was located, it could be understood as a kind of stonewares made in local. Generally speaking, or according to the archaeological studies about mortars with grater in Japan, these typed wares have been basically used for grinding or braying foods or medical materials. This specimen, however, has not so sharp edged teeth that it is unlikely useful for processing foods or medicines. Furthermore, the surface on grating part of the specimen does not seem to be worn out or used well at all, while the surface only at the center of interior bottom gets slightly smoother. On the other hand, the center of bottom was chipped off and made a hole. Therefore, there might be another possibility that the specimen had been broken and abandoned before using well.

TP17-S2 is a rim to body part of jar with wide mouth. Among the stoneware findings, 11 pieces of fragments may belong to the specimen, while most of the shards actually can not adjoined with each other. Its proportion should be a kind of jar, but it has an open shape with a part of the upper body curving inwards and with a flared short mouth-rim. Diameter at inner top of mouth-rim is estimated to measure around 14cm, which is slightly narrower than its shoulder part. The paste is relatively fine grained and solid. Its colour varied from light grey to dark grey, as the specimen was a little ill-fired.

There are natural fly-ash extended partially on the exterior shoulder.

## Imported ceramics

Imported ceramics unearthed from the Test Pit 17 count 39 pieces in total. The findings are mainly categorized into the underglazed blue and white ware, but the specimens demonstrate profuse variations in their origin and dating, which includes modern products also. They are classified roughly as follows, while most of them are so small fragments that it is quite difficult to identify each specimen precisely.

Chinese underglazed blue and white wares in Ming dynasty or during 16th to early 17th centuries: eight pieces, consisting of five pieces of bowl (two shards of rim part and three shards of base part) and three pieces of plate (two shards of base part and one shard of body part).

Chinese underglazed blue and white wares in Qing dynasty or between the late 17th to 19th centuries: 11 pieces of bowl (two shards of base part, six shards of body part and three shards of rim part).

Chinese underglazed blue and white wares in later Qing dynasty or modern period after 19th century: nine pieces of bowl (four shards of body part and five shards of rim part)

Chinese white porcelain: one piece of lid or box cover (rim part) and one piece of bowl (body part) which is "Bluish white" or "Qing-pai" ware probably manufactured in Jindezhen kiln groups during Yuan Dynasty.

Celadon probably made in China: one piece of unidentified object (lug or knob part of vessel, or some kind of figure)

Thai's celadon glazed stoneware around 15th century: two pieces of plate (body parts) .

Vietnamese underglazed blue and white ware in 16th to the early 17th centuries: one piece of bowl (base part) and one piece of lid or box cover.

Porcelain with underglazed blue and white decoration probably manufactured in Japan between the late of 19th and early in the 20th centuries: three pieces of dish (two shards of rim part and one shard of base part, all of which were adjoined with each other ) and one piece of plate (base part).

TP17-I1 is a base part of Chinese underglazed blue and white plate with small foot-rim, which may have been manufactured at kilns in Guangdong or Fujian provinces during Ming dynasty or the 16th to early 17th centuries. Its estimated size measures about 6.8cm in the outer diameter at bottom end of the foot-rim. The paste is light greyish white or almost white coloured, solid but relatively coarse including many black particles. There are also many pores presented in the paste. Underglaze decoration was painted in light greyish blue coloured. While the detailed motif of decor is not clear, its brush touch with gradation in blue colour may be characteristic in some products during Ming period. The glaze is pale white coloured, slightly opaque with many bubbles and black particles inside. It covers whole surface of interior and exterior of the remained part, including even the bottom end of foot-rim and inner part of the foot-ring also. There are a lot of sand grains or some other substances attached to the inside wall of foot-ring, which materials may have been used for preventing the ware from stacking with other wares piled up in the kiln during firing.

TP17-I2 is a base part of Chinese underglazed blue and white bowl. Its estimated size measures about 4.2cm in the inner diameter at bottom end of the foot-rim. The paste is light brownish grey coloured, solid but relatively coarse for porcelain. Its broken edges are bumpy with pores. There is underglaze decoration of a framed hallmark of Chinese character "Long (Lung)" which means dragon, remained at the exterior base inside of foot-ring. It is written in clear indigo blue colour. These hallmarks by one letter of Chinese character had been quite popular among Chinese blue and white wares throughout Ming and Qing dynasties. They had varied widely, while same letter had been used at several kilns in different provinces simultaneously, also used continuously for hundreds of years. Therefore, it is difficult to identify and date each finding only by these marks. The glaze is light olive green in colour, which is similar to the colour of some kinds of Chinese celadon glaze. It is transparent and shined well. There is no glaze only at the bottom end of foot-ring. These colours and textures of paste and glaze used in the specimen seem like the characters of products in Dong-an kiln groups, but it is not clear about exact production kiln. The specimen may have been manufactured at some kiln in Guangdong or Fujian provinces during Qing dynasty or between the late 17th and 19th centuries.

TP17-I3 is a base part of Chinese blue and white bowl, which has quite similar characteristics with the above-mentioned specimen, TP17-I2. Its size measures about 4.0cm in the outer diameter at bottom end of the foot-rim. The paste is light brownish grey coloured, solid but slightly coarse, as many pores exist. There is underglaze decoration of a framed hallmark of Chinese character remained at the exterior base inside of foot-ring. It is written in light bluish gray colour. As the mark is blurred and the half part has been lost, its letter can not be read. The glaze is light greenish gray, which is lighter than I2 in colour. It is transparent and shined well. There is no glaze only at the bottom end of foot-ring. There are sand grains or some other substances attached to the inside wall of foot-ring. The specimen may have been also manufactured at some kiln in Guangdong or Fujian provinces during Qing dynasty or between the late 17th and 19th centuries.

TP17-I4 is a small dish with underglazed blue and white decoration. The specimen remains from foot-ring of base to mouth-rim partially, consisting of three shards which are adjoined with each other. Its sizes measure 8.6cm in diameter at the top end of mouth-rim and 2.65cm in full height. The paste is greyish white coloured, solid but slightly coarse, including many small black particles. The underglazed decoration of a series of dotted flower and triangle (or



chevron) motives are existed on all over the exterior wall, the upper interior rim and interior bottom. These decors which present vivid cobalt blue in colour were made by not painting with brush but stencil-printing. The glaze is nearly colorless, transparent and shines well. As far as considering about its characteristics of pigment and technique used for the decoration, the specimen can be identified to be a Japan product probably fired in Hizen kilns during the latter 19th to early 20th centuries.

TP17-I5 is a base part of large bowl or plate with underglazed blue and white decoration. Its size measures 11.8cm in outer diameter at the bottom end of foot-ring. The paste is nearly white coloured, fine and solid, while including many small black particles. The underglazed decoration of peony or other flower motives exists on the interior bottom. The decor which colour presents vivid blue occurred from cobalt, were made by stencil-printing, as same as the specimen TP17-I4. The glaze is pale white, nearly transparent and shiny. There is no glaze at the circular area inside foot-ring on its exterior bottom, while the center circle on the exterior bottom is glazed. The specimen seems to be manufactured in Japan (possibly at Hizen kilns) during the latter 19th to early 29th centuries, considering about its characteristic technique and coloring of the decoration.

TP17-I6 is a small shard of celadon or celadon glazed stoneware. Its original shape or the complete form of parent ware, to which the specimen should attach can not be identified, therefore it is unknown about typology of the object.

The remained shape seems something like a fish tail, it is likely to be a lug or knob part of vessel. Its form, however, does not present symmetrical proportion or design between the front and its reversal side. There is a possibility that the specimen is a part of decorative object, such as figures or zoomorphic vessels. The paste is light grey coloured, relatively solid but coarse and rough. The glaze is light olive green, slightly opaque with some bubbles and cracks inside. The specimen was probably made in China during Ming dynasty, while its paste seems to be similar to Thai's celadon glazed stoneware rather than Chinese.

#### Earthenware

There are 82 pieces of earthenware recovered at the Test Pit 17, that is not including a complete form. The shapes of rim parts counting 17 pieces do not vary, but have common proportions with others such as the findings from TP11. The photo plate shows two pieces with special formed earthenware. One piece is assumed to be a lug or foot part of vessel, probably a kind of cooking pot because of much soot stuck on the exterior surface. Another specimen is a disk of clay with many holes. Its estimated whole size measures around 12cm in diameter, the thickness is 1.1~1.3cm. The object is considered to be used for cooking, probably steaming foods.

There are also nine pieces of jar typed wares with characteristic impressed decorations also recovered, as shown in the photo plate.



TP17-S1

10cm



TP17-S2



TP17-11



TP17-12



TP17-15



TP17-13



TP17-14



TP17-16



Earthenware pieces from TP17  10cm

# TEST PIT 18

Location: Near Khoun Boulom/Samsenthai Junction.

Excavation Date: August 3rd, 2004

Identified Working Infrastructure(s): None

Identified Archaeological Feature(s): None

Recovered Artifacts: 1074

Stoneware: 44, Earthenware: 927, Imported ceramics: 33,

Glass: 5, Stone: 3, Brick: 18, Metal Object: 14,

Stucco/Mortar: 7, Wooden Object: 1, Roof Tile: 16, Bone: 6

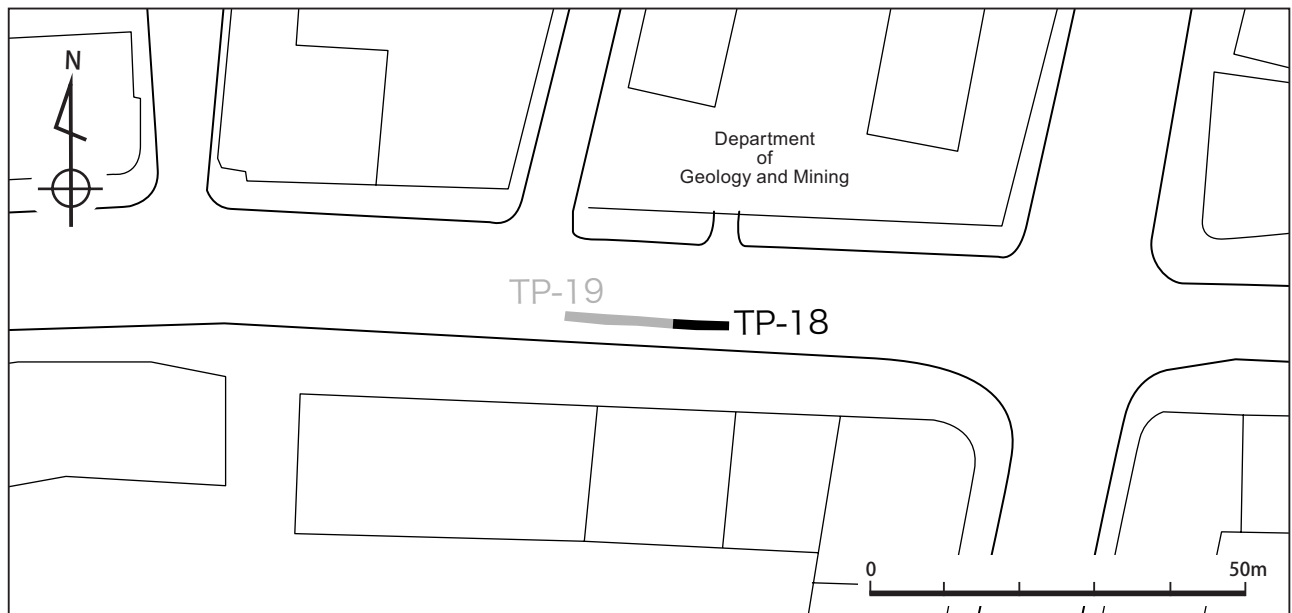
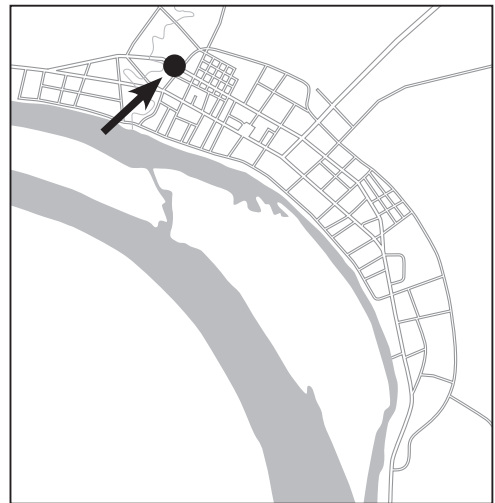

**Point E18-11**  
 Coordinates:  
 X=88,404.629  
 Y=46,143.261  
 EL=171.05m

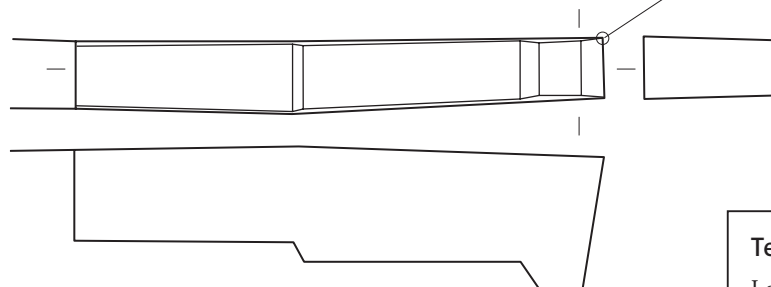

**Test Pit Dimention (max.)**

Length: 7.00m

Width: 1.00m

Depth: 1.72m

Area: 7.00m<sup>2</sup>





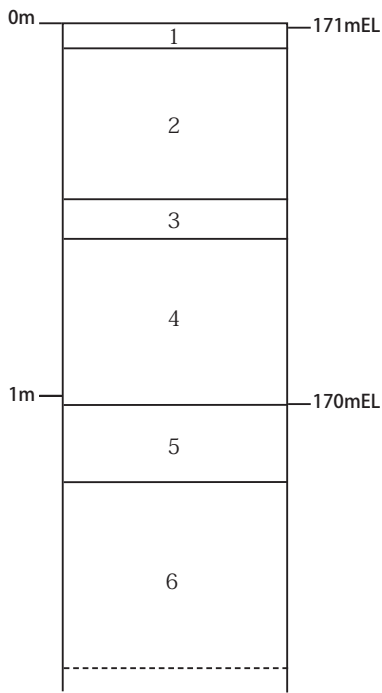

**Explanation of Soil Layers**

- 1 Asphalt: Present road surface.
- 2 Pebble/Laterite soil: Sub-base layer for the present road surface.
- 3 Light grey sand: Sub-base layer for the present road surface?
- 4 Dark grey-brown silt layer with broken pieces of concrete, bricks and stones. Probably the sub-base layer for the earlier road surface.
- 5 Dark grey silty clay. Artifacts found from this layer.
- 6 Grey silty clay: Uniform and with no inclusion.



**Artifacts**

**Roof tiles**

16 shards of thin flat roof tiles were unearthed.

**Bricks**

18 broken blocks of bricks were unearthed. Each of 2 blocks of them keeps its width and thickness (see the list below). Some of these bricks may be components of the inner city wall of Vientiane.

Width	Thickness
117	36
132	60

Measurments of bricks from TP18 (mm)

**Wooden objects**

1 decayed thin board in the shape of semicircle was unearthed. Its original function is unknown.

**Metal objects**

1 rusted wire nail (approximately 102 mm of the length), 1 ring (approximately 60 mm in diameter), 1 small plate with alphabets carving, 3 parts of the dry cells, and 8 small fragments were unearthed. All of them are probably



View of the surroundings of Test Pit 18



Situation of prehistoric(?) pottery cluster

productions in and/or after the French period.

#### Stucco/Mortar

7 blocks of stucco were unearthed. 1 of them is a part of the molding.

#### Stoneware

From the excavation at the test pit 18, large amounts of earthenware shards counting 927 pieces were unearthed, while there are not so many pieces of stoneware and imported ceramics recovered. The stoneware shards count 44 pieces in total, which are classified and counted in each shape class as follows; mortar or large bowl type wares: 12 pieces (three pieces of outward angled rim part, eight pieces of body and one piece of base part), and jar type wares: 32 pieces (six pieces of base part, 25 pieces of body part and one piece of rim part).

Among all these stoneware findings, nine shards with relatively fine grained paste, present greyish white to beige in colour of the paste which should be the results of ill-firing. On the other hand, other shards of around 10 pieces had light greenish grey to dark purplish brown colored natural glaze effect on their surfaces, from fly-ash deposited during firing.

TP18-S1 is a rim to body part of mortar or large bowl with outward angled rim. Its estimated size measures 25.8cm in outer diameter at the top end of mouth-rim. The paste varies in colour from dark grey at inside of body to brown or blackish brown on the surface. Its texture is relatively solid and even, but slightly coarse and bumpy at their broken edges. There is natural glaze in dark purplish brown colour occurred on the upper surface at both side of the wall. There are also many spots and dots spread over its shoulder part, which present light brown in colour, probably effecting from iron included in the clay of paste.

#### Imported ceramics

Imported ceramics unearthed from the Test Pit 18 count 33 pieces in total. As similar to the typological tendency at TP17, the findings are mainly categorized into the underglazed blue and white ware, and the specimens also demonstrate wide variations in their origin and dating, while there is no Vietnamese ware confirmed. They are classified roughly as follows; Chinese underglazed blue and white wares in Ming dynasty or during 16th to early 17th centuries: five pieces, consisting of two pieces of bowl (two shards of body part), one piece of plate (base part) and two pieces of small bottle or jar (body part), Chinese underglazed blue and white wares in Qing dynasty or between the late 17th to 19th centuries: 11 pieces, consisting of ten pieces of bowl (five shards of body part and five shards of rim part) and one piece of plate (base part), Chinese underglazed blue and white wares in later Qing dynasty or modern period after 19th century: nine pieces, consisting of eight pieces of bowl (two shards of base part, three shards of body part and three shards of rim part), Chinese white porcelain: one piece of bowl (rim part) probably in Yuan dynasty, two pieces of dish (base parts of same ware) probably in modern period or 20th century and one piece of lid or box cover (body part) which date can not be clarified., Thai's celadon glazed stoneware around 15th century: one piece of plate (body part) and porcelain with underglazed blue and white decoration probably manufactured in Japan during the 18th to 19th centuries: one piece of bowl (rim part).

TP18-I1 is a body (shoulder) part of small jar with wide mouth of Chinese underglazed blue and white probably dated in Ming dynasty. Its size can not be clarified, but the estimated diameter at its widest shoulder part measures around 7.4cm. The paste is nearly white, fine and solid, while including many fine black particles. There is underglazed decoration of flamed flower design on the exterior. Its decor is painted in beautiful indigo blue with light and shade. The glaze is pale transparent, which shine on the surface is lost slightly with many scratches. From these characteristics of paste, glaze and motif and colour of decoration, the specimen can be identified to be the Chinese Jindezhen kiln products in later Ming dynasty or during 16th to early 17th centuries.

TP18-I2 is a rim part of Chinese underglazed blue and white bowl. Among the unearthed ceramics, five shards may belong to the same one specimen. The similar typed wares to this can be confirmed at other findings from the several test pits such as TP04, 08, 16, and so forth. Its paste is grey coloured, solid but coarse with many pores. The underglazed decorations of floral scroll or some other abstract motives were painted in dark blue colour with running

touch on the exterior body. The glaze is pale greyish white, slightly opaque with many bubbles. The specimen was manufactured probably in later Qing dynasty or between the 18th and 19th centuries.

#### Earthenware

From the Test Pit 18, most profuse amounts of earthenware were unearthed. The findings count 927 pieces in total, however there is no ware remained complete form. It should be noted that the shape-classes of findings are limited on the large jar typed wares only. Furthermore it is quite curious that there is no shard of base part included among the 927 pieces, that is, all the shards are rim to body parts of large jars. The shapes of rim parts unexpectedly demonstrates not so wide variations, while presenting slightly different proportional tendency in comparison with the findings from other Test Pit s, such as TP11. The major types of rim shapes, as shown in the photo plate, are prominent and flared mouths with outward-inclined profiles. Many of their top ends are slightly in-turned or bent to inward. The other types of straight standing mouth with thickened rim ends are also included, but they are predominantly minor against the flared type (in fact, they are only eight pieces, while the flared types count 126 pieces).

On the other hand, there are also profuse amounts (134 pieces) of jar typed wares with characteristic impressed decorations of a series of short oblique lines and herringbone-like motifs also recovered, as shown in the photo plate.



TP18-S1

10cm





TP18-I1



TP18-I2



Earthenware pieces from TP18 (1)



Earthenware pieces from TP18 (2)



Earthenware pieces from TP18 (3)



# TEST PIT 19

Location: Near Khoun Boulom/Samsenthai Junction.

Excavation Date: August 4th, 2004

Identified Working Infrastructure(s): None

Identified Archaeological Feature(s): 2

Recovered Artifacts: 403

Stoneware: 27, Earthenware: 5, Imported ceramics: 24, Bone: 32,  
Glass: 47, Stone: 2, Brick: 194, Metal Object: 21, Stucco/Mortar: 49,  
Roof Tile: 2

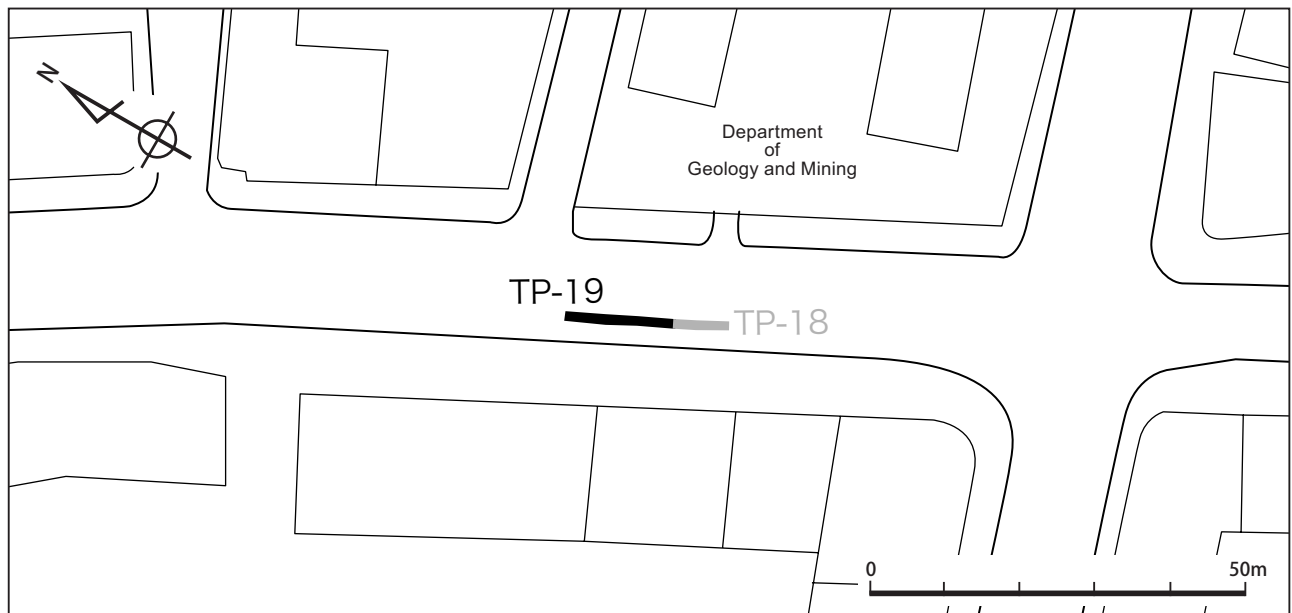
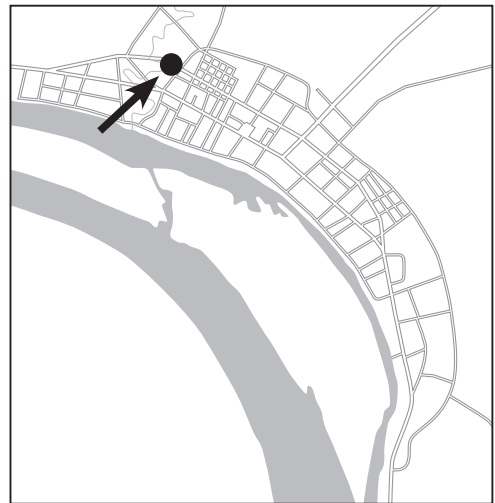

**Point E19-103**

Coordinates:  
X=88,415.183  
Y=46,124.775  
EL=171.12m

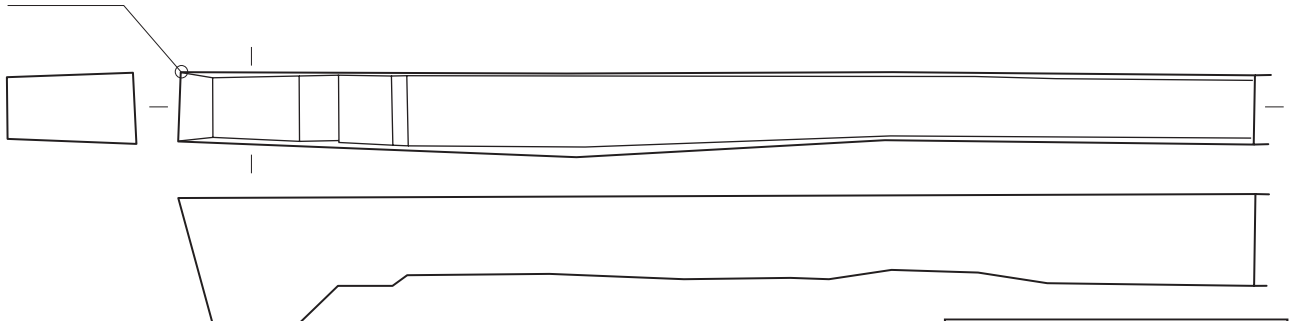

Test Pit Dimention (max.)	
Length:	14.28m
Width:	1.15m
Depth:	1.68m
Surface Area:	14.23m <sup>2</sup>

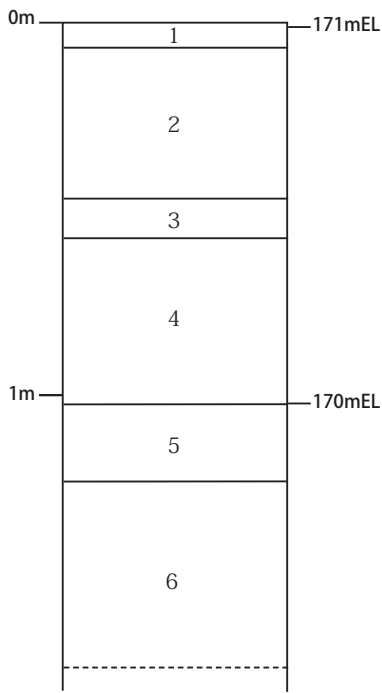

### Explanation of Soil Layers

- 1 Asphalt: Present road surface.
- 2 Pebble/Laterite soil: Sub-base layer for the present road surface.
- 3 Light grey sand: Sub-base layer for the present road surface?
- 4 Dark grey-brown silt layer with brokenpieces of concrete, bricks and stones. Probably the sub-base layer for the earlier road surface.
- 5 Dark grey silty clay. Artifacts found from this layer.
- 6 Grey silty clay: Uniform and with no inclusion.



View of the surroundings of Test Pit 19



Brick structure (TP19-ST1) *in situ*



Brick structure (TP19-ST2) *in situ*



Excavation in progress



## Structures

2 brick structures were detected at south side of this trench (about 1 m in depth).

The west structure was a corner part of brick row laid by a stretcher bond without mortar (TP19-ST1). This structure was dismantled for further excavation and those bricks were picked up.

The east one had a semicircular plan built by broken blocks without mortar (TP19-ST2). Its construction technique was very poor. This structure was not dismantled and refilled by sand for further study in the future.

The functions of these brick structures are not identified, because they were disturbed by the south wall of trench, and the rest parts seemed to continue to outside of trench area.

Furthermore, 2 groups of scattered bricks were found in this trench, but it was not sure that they were parts of structures or not.

## Artifact

### Roof tiles

Only 2 shards of thin flat roof tiles were unearthed.

### Bricks

193 broken blocks of bricks were unearthed. Each of 33 blocks of them keeps its width and thickness (see the list below). 1 broken thin block (approximately 20 mm of the thickness) of floor tile(?) was also unearthed. Some of these bricks may be components of the inner city wall of Vientiane.

### Metal objects

1 part of the rusted wire nail, 1 rusted peg (approximately 180 mm of the length), 3 pieces of rusted wires, 1 piece of iron bar, 5 parts of the dry cells, 4 parts of machines, 1 small piece of melted slug, 1 piece of the fitting(?), 1 lid made of aluminum, and 3 small fragments were unearthed. All of them are probably productions in and/or after the French period.

### Stucco/Mortar

49 blocks of stucco were unearthed.

### Stoneware

There are not so many ceramics recovered from the excavation at Test Pit 19. The stoneware shards count only 27 pieces in total. There is no significant specimen to be selected for reporting. The findings are classified and counted in each shape class as follows; Mortar or bowl type wares: 12 pieces (four pieces of rim part, six pieces of body and two pieces of base part) and jar type wares: 15 pieces (four pieces of base part, ten pieces of body part and one piece of rim part).

### Imported ceramics

Imported ceramics unearthed from the Test Pit 19 exist not so many pieces, counting only 24 pieces in total. However, the findings show unexpectedly wide variations in their origin and dating. Especially it should be noted that they include comparatively older products, such as Chinese ware during Southern Sung to early Yuan dynasties. The specimens are classified and counted as follows; Chinese underglazed blue and white wares in Ming dynasty or during 16th to early 17th centuries: two pieces, consisting of one piece of bowl (its body part) and one piece of small jar (its body part), Chinese underglazed blue and white wares in later Qing dynasty or modern period after 19th century: three pieces of bowl (two shards of rim part and one shard of base part), Chinese white porcelain: one piece of bowl (base part) probably dated in early Yuan dynasty and one piece of an insulator for electric wire in the 20th century, Chinese

Width	Thickness	Remarks
97	46	
100	48	
102	43	
102	48	
105	36	
105	44	
106	52	mortar adheres
107	38	
108	44	
108	49	
109	42	
110	40	
110	42	
110	44	
110	47	
110	47	
110	50	
112	38	
112	47	
112	50	
112	53	
113	41	
113	49	
113	57	
114	42	
115	50	
117	42	
117	45	
118	39	
118	47	
118	51	
120	48	
130	50	

Measurements of bricks from TP19 (mm)

brown glazed stoneware: one piece of jar (one shard of base part and seven shards of body part, all of them belong to the same one piece) which may be manufactured during Southern Sung or early Yuan dynasties, as mentioned below, Thai's celadon glazed stoneware around 15th century: two pieces of plate (one shard of body part and one shard of rim part) and one piece of jar or bottle (body part), Thai's underglaze iron painted ware: one piece of bowl (body part) which was probably fired at Kalong kiln groups during 14th to mid-16th centuries, Thai's brown glazed stoneware: one piece of jar (rim part), Vietnamese underglazed blue and white ware: two pieces of bowl (one shard of base part and one shard of body part) which can be dated in late 16th to the 17th centuries, and one piece of lid or box cover (body part) which was probably dated in mid-15th to 16th centuries, and Vietnamese over-glazed enamel painted ware: one piece of bowl (body part)

On the other hand, it is generally understood that the area where test pits 17, 18 and 19 are located has been regarded as just a small village or ordinal people's living area until modern period, as far as referring documents. The contents of imported ceramics unearthed from these three test pits, however, demonstrate profuse variations about their origin and dates especially including older products. It means that the area should have been used historically as some place with commercial factor or the living section for some classed people, rather than just an ordinal village.

TP19-I1 is a base part of Chinese white porcelain bowl. There is no decoration observed on the remained part. Its size measures 5.4cm in outer diameter at the bottom end of foot-ring. The paste is light grey coloured, solid but slightly coarse with some pores. The glaze is pale greyish white coloured, transparent and shiny. There is no glaze at the bottom end of foot-ring which presents light brown in colour probably effected from iron in the paste. Depending on its characteristic quality of paste and glaze, the specimen may be regarded as the older Chinese products probably made in Jindezhen or some other related kilns in Southern China during early Yuan or Southern Sung dynasties (the latter 13th to 14th centuries).

TP19-I2 is a base part of Chinese brown glazed stoneware. There is not remained its full proportion, but it is possible to be a deep basin or mortar shaped ware with outward wide mouth-rim. Its size measures around 10.5cm in diameter at the outer bottom end. The paste is light brownish grey coloured, quite solid but slightly coarse including many white particles (feldspar). Its glaze is dark brown coloured, which layer is very thin but opaque. There is even but dull shine on the surface of glaze. Considering about these conspicuous characteristics of its shape-class, paste and glaze, the specimen can be identified to be the comparatively older Chinese product which was manufactured probably at Quan-zhou kilns in Fujian or Ghan-zhou kilns in Jiangxi province during the latter Southern Sung dynasty or in the 13th century. It is known that the same kind of wares as this have been discovered at the several archaeological sites in the middle age period in Japan such as Dazaifu, Hakata, Kamakura and so on.

TP19-I3 is a rim part of large jar, which is brown glazed stoneware probably manufactured in Northern Thai kilns during 15th to 16th centuries.

#### Earthenware

There are only five pieces of earthenware recovered at the Test Pit 19. Most of the shards are small fragments. One shard of base part has same shape as the specimen recovered at the TP15, which is reported above with a photo. There is no significant specimen to be reported individually with photos.



TP19-11



TP19-13



TP19-12



# TEST PIT 20

Location: Near Khoun Boulom/Setthathilat Junction.

Excavation Date: August 5th to 6th, 2004

Identified Working Infrastructure(s): None

Identified Archaeological Feature(s): Brick structure: 1

Recovered Artifacts: 210

Stoneware: 2, Earthenware: 3, Imported ceramics: 2, Bone: 45,

Glass: 2, Brick: 152, Metal Object: 2, Stucco/Mortar: 1, Roof Tile: 1

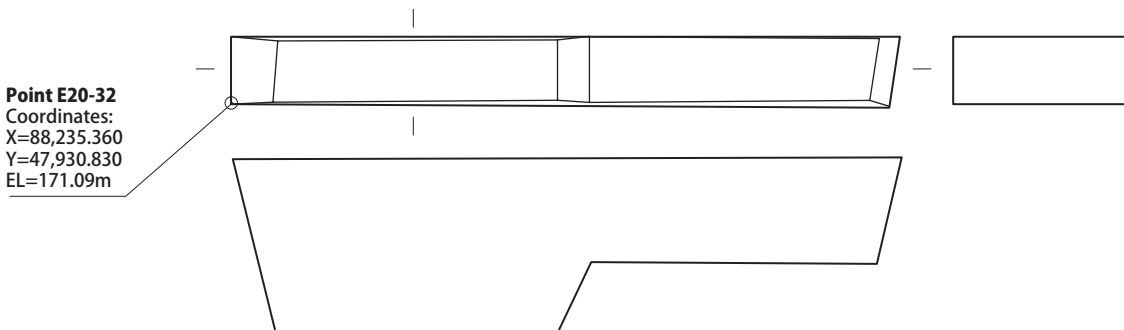
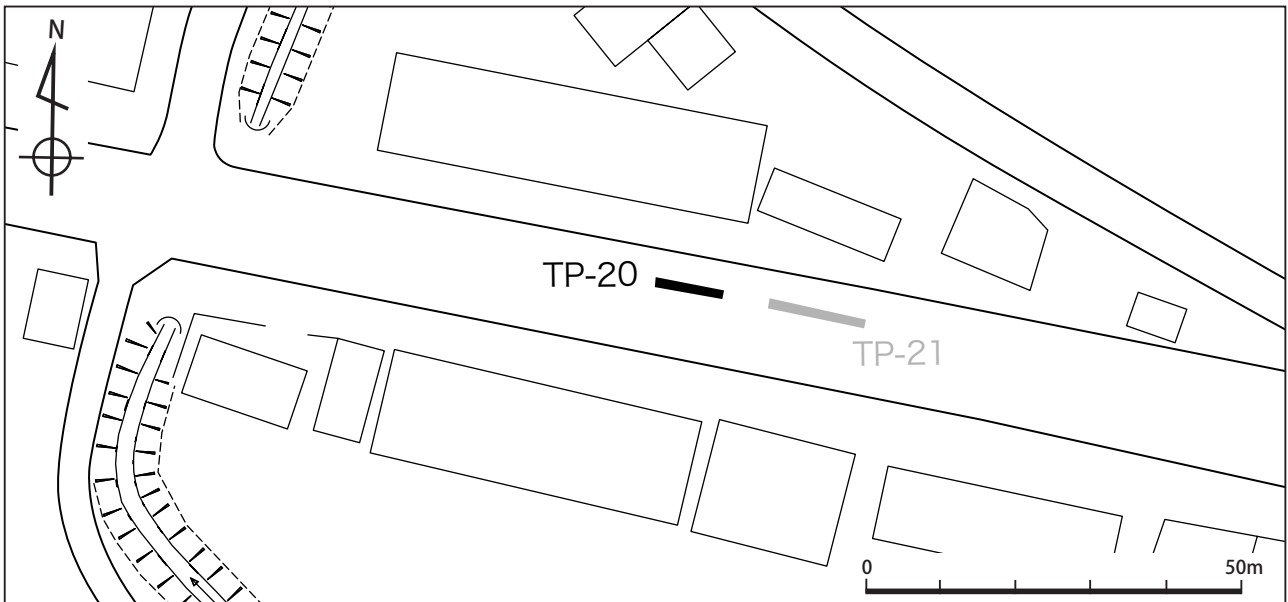
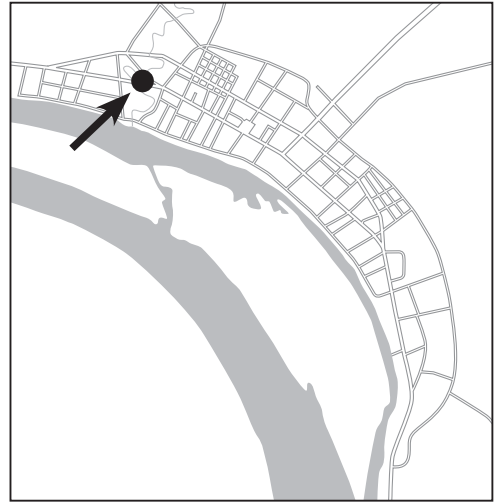

Test Pit Dimention (max.)	
Length:	8.87m
Width:	1.00m
Depth:	2.28m
Surface Area:	8.87m <sup>2</sup>

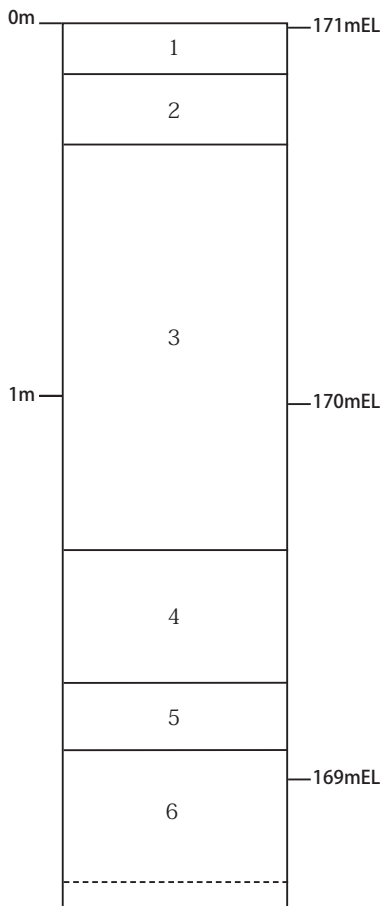

**Explanation of Soil Layers**

- 1 Asphalt: Present road surface.
- 2 Pebble/Laterite soil: Sub-base layer for the present road surface.
- 3 Dark grey-brown silt layer. Probably sub-base layer for the earlier road surface.
- 4 Dark grey silty clay. Artifacts found from this layer.
- 5 Grey silty clay: Uniform and with no inclusion.
- 6 Grey clay: Uniform and with no inclusion.



View of the surroundings of Test Pit 20



Excavation under progress



Brick structure *in situ*



Section of the brick structure

## Structures

A brick structure extending north-south direction without mortar was detected (about 1 m in depth, TP20-ST1). This structure had 2 layers partially, and its width (east-west direction) is about 1.5 m. This may be a temporary pavement, because only broken blocks were used and its construction technique was very poor.

This brick structure was dismantled for further excavation, and those bricks were picked up.

## Artifacts

### Roof tiles

Only 1 shard of thin flat roof tile was unearthed.

### Bricks

150 broken blocks of bricks were picked up. Almost of them were components of the brick structure mentioned above. Each of 31 blocks of them keeps its width and thickness (see the list below). 2 broken thin blocks (approximately 20 mm of the thickness) of floor tiles (?) were also unearthed.

### Metal objects

1 part of the rusted nail and 1 small rusted plate were unearthed.

### Stucco/Mortar

1 block of stucco was unearthed.

### Stoneware

There are very few ceramics recovered from the excavation at Test Pit 20. The stoneware shards count only 2 pieces in total, which are consisting of one piece of mortar type ware (base part) and one piece of jar (body part). These are small fragments and not to be selected for reporting.

### Imported ceramics

Imported ceramics unearthed from the Test Pit 20 also count only two pieces, which are classified into one piece of Chinese underglazed blue and white bowl (body part) in modern period after 19th century and one piece of brown glazed large jar (rim part) probably made in Thai between 15th and 16th centuries.

### Earthenware

There are only three pieces of earthenware recovered at the Test Pit 20. One shard of rim part presents common shape to the specimens recovered at the TP11, which are reported above with photos. There is no specimen to be reported individually.

Width	Thickness
87	38
92	53
98	34
100	40
100	44
100	49
100	60
102	36
102	42
102	44
102	45
102	48
104	40
105	46
105	48
105	55
106	40
106	40
110	42
110	43
110	46
110	51
111	45
112	47
112	48
115	48
115	55
116	46
125	51
127	45
140	58

Measurements of bricks from TP20 (mm)



# TEST PIT 21

Location: Near Khoun Boulom/Setthathilat Junction.

Excavation Date: August 5th to 6th, 2004

Identified Working Infrastructure(s): Telephone line: 1

Identified Archaeological Feature(s): None

Recovered Artifacts: 146

Stoneware: 3, Earthenware: 6, Imported ceramics: 23, Bone: 24,

Glass: 13, Brick: 43, Metal Object: 6, Stucco/Mortar: 6, Roof Tile: 8

Note: Excavation of this test pit was intended to find the remnant of inner city wall, however, no trace of it was unearthed. The remain of a brick foundation of the French-colonial era was found,

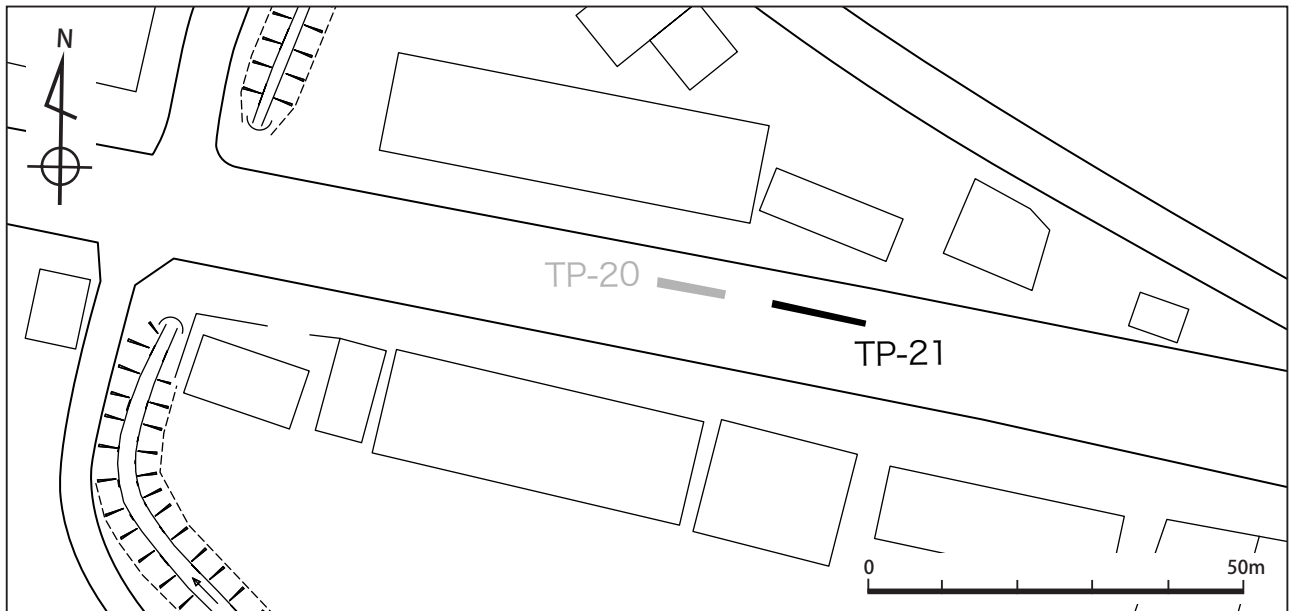
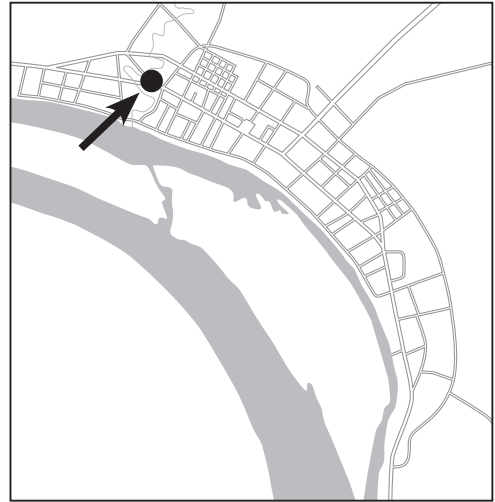

**Point E21-2**  
Coordinates:  
X=88,233.346  
Y=45,958.202  
EL=171.12m

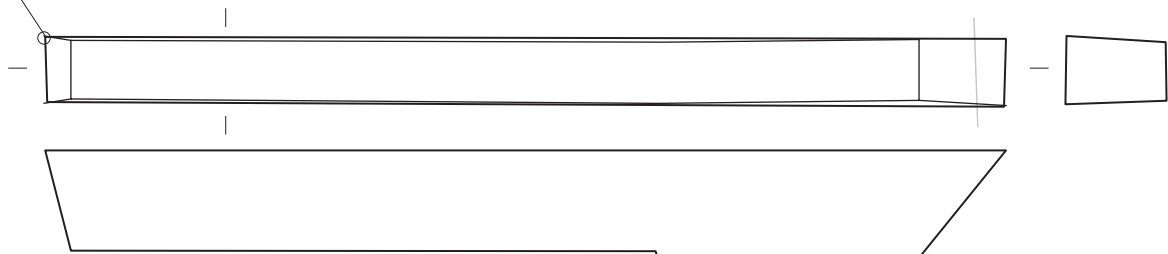

### Test Pit Dimension (max.)

Length: 12.76m

Width: 0.89m

Depth: 1.41m

Surface Area: 11.36m<sup>2</sup>

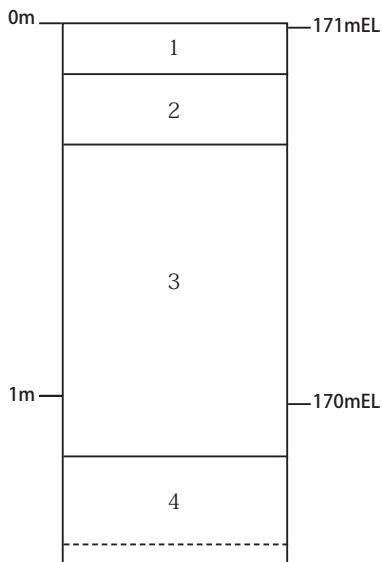

**Explanation of Soil Layers**

- 1 Asphalt: Present road surface.
- 2 Pebble/Laterite soil: Sub-base layer for the present road surface. Include concrete blocks.
- 3 Dark grey-brown silt layer. Probably sub-base layer for the earlier road surface.
- 4 Dark black silty clay layer. Include modern rubbish and bricks.



**Structure**

A brick structure extending north-south direction was detected (about 90 cm in depth, TP21-ST1). This brick structure with mortar for bonding had 6 layers partially in the “French style.” This is probably the base of building in the French colonial period.

This brick structure was dismantled for further excavation, and 15 pieces of bricks were picked up. The size of these bricks are 208 ~ 217 mm long, 100 ~ 107 mm wide, and 55 ~ 60 mm thick.

Width	Thickness	Remarks
132	9	A part of front end
132	9	A part of front end
140	8	A part of front end

**Artifacts**

**Roof tiles**

Eight shards of flat roof tiles with mortar were unearthed. Four of them are front parts of round-shaped type (TP21-R1 ~ R4). Other 3 shards, which probably are parts of same type, have the projections as stopper at the only center of each (TP21-R5 to R7). Each 3 of 8 shards keeps its full width (see the list below).

Measurements of roof tiles from TP21 (mm)

rear end (TP21-R5 to

**Bricks**

16 pieces of bricks, each of which keeps its original length, width, and thickness, 20 broken blocks, and 7 broken thin blocks (approximately 20 mm of the thickness) of floor tiles (?) were picked up. 15 pieces of 16 complete ones were components of the base structure mentioned above.

Each of 19 broken blocks keep its width and thickness (see the on the next page). Another one is a broken part of block in the shape of half-cylinder (approximately 54 mm of the radius). The finish of its curved surface is rough and stucco/mortar adheres to there (TP21-B1a, b). The original function of this block is unknown.



View of the test pit after excavation



Colonial-era brick foundation

**Metal objects**

1 piece of rusted wire, 1 small bowl, and 4 fragments of thin plates were unearthed. All of them are productions in and/or after the French period.

**Stucco/Mortar**

6 blocks of stucco were unearthed.

**Stoneware**

There are quite small amount of ceramics recovered from the excavation at Test Pit 21. The stoneware shards count only three pieces in total, which are consisting of one piece of mortar type ware (body part) and two pieces of jar (body parts). These are all small fragments and not to be selected for reporting.

**Imported ceramics**

Imported ceramics unearthed from the Test Pit 21 exist not so many pieces, counting only 23 pieces in total. The specimens are classified and counted as follows; Chinese underglazed blue and white wares during Qing dynasty: nine pieces of bowl (eight shards of rim part and one shard of body part), Underglazed blue and white wares in modern period after 19th century, which origin may be in China or Vietnam: nine pieces of bowl (five shards of rim part, two shards of body part and two shards of base part), Chinese celadon glazed stoneware in possibly modern period: one piece of round box with three Chinese characters molded on the exterior bottom, Thai's brown glazed stoneware: two pieces of jar (one shard of rim part and one shard of body part), Vietnamese underglazed blue and white ware: one piece of bowl (body part).

Length	Width	Thickness
	98	46
	100	48
	102	40
204	102	43
	103	52
	104	44
	104	50
	111	58
	112	40
	113	38
	113	40
	113	48
	116	56
	118	44
	120	59
	122	48
	125	53
	127	46
	130	53
	135	55

Measurements of bricks from TP21 (mm)

**Earthenware**

There are only six pieces of earthenware recovered at the Test Pit 19. All the shards are shoulder to body parts of large jar typed wares. There is no significant specimen of rim part or shard with decorations to be reported individually.



TP21-R1 - R4



TP21-R5 - R7



TP21-B1



10cm



# TEST PIT 22

Location: Near Vat Impeng. Within the range of old Vat Impeng perimetre.

Excavation Date: August 9th, 2004.

Identified Working Infrastructure(s): None

Identified Archaeological Feature(s): None

Recovered Artifacts: 133

Stoneware: 7, Earthenware: 1, Imported ceramics: 7, Stone tool: 1,

Stone: 2, Brick: 51, Metal Object: 23, Stucco/Mortar: 14,

Roof Tile: 118

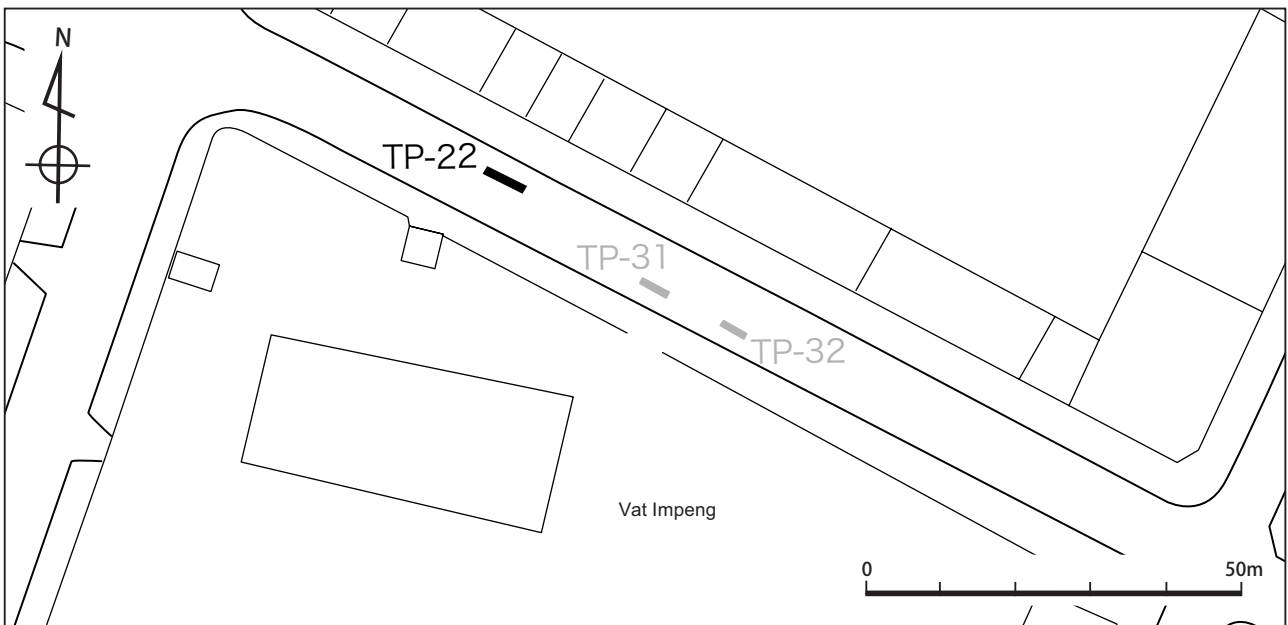
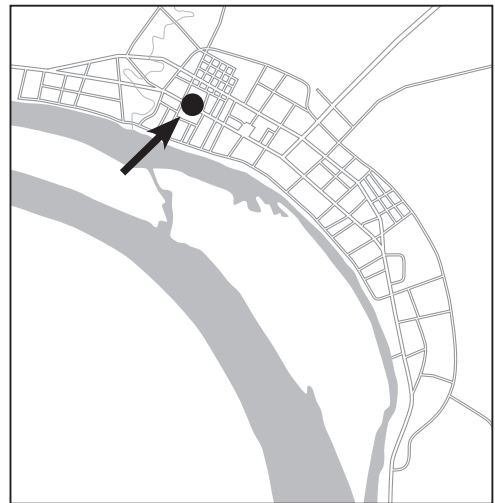

**Point E22-20**  
Coordinates:  
X=88,186.439  
Y=46,103.400  
EL=170.70m

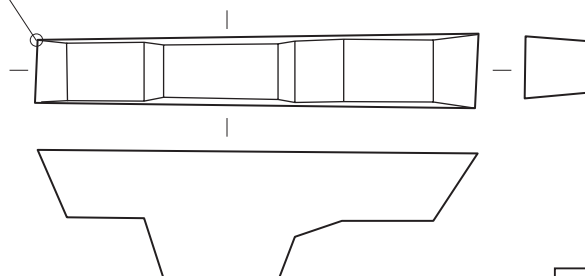

Test Pit Dimention (max.)	
Length:	5.84m
Width:	1.03m
Depth:	1.72m
Surface Area:	6.02m <sup>2</sup>

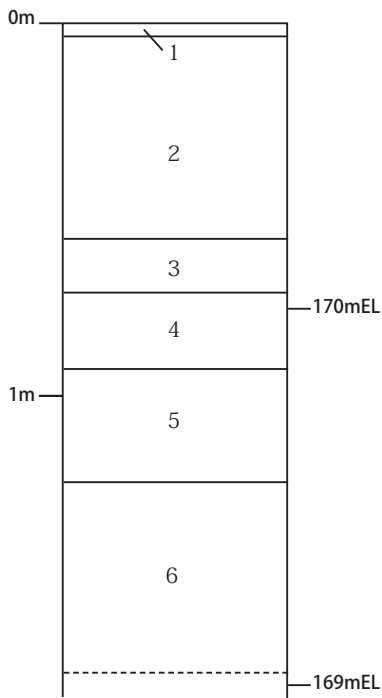

**Explanation of Soil Layers**

- 1 Asphalt: Present road surface.
- 2 Pebble/Laterite soil: Sub-base layer for the present road surface.
- 3 Dark grey-brown silt layer. Probably sub-base layer for the earlier road surface.
- 4 Dark grey silty clay. Artifacts found from this layer.
- 5 Grey silty clay: Uniform and with no inclusion.
- 6 Grey clay: Uniform and with no inclusion.



**Artifacts**

**Roof tiles**

118 shards of flat roof tiles were unearthed. 52 shards of them are fragments of thick tiles (14 to 16 mm), other 66 shards are fragments of thin tiles (4 to 9 mm). Each 2 of 118 shards keeps its full width (see the list below, TP22-R1, R2).

Width	Thickness	Remarks
137	6	thin tile, a part of front end
159	16	thick tile, a part of rear end with stopper

**Measurements of roof tiles from TP22 (mm)**

The trace of texture is observed on the one surface of the each of 11 shards. The thickness of these whitish shards are 7 ~ 9 mm.

Width	Thickness
104	48
105	45
105	45
110	38
110	48
110	49
115	47
120	45
122	55
122	58
123	45
126	53
132	52
148	43

**Measurements of bricks from TP22 (mm)**

**Bricks**

51 broken blocks of bricks were unearthed. Each of 14 blocks of them keeps its width and thickness (see the list below).

**Metal objects**

10 complete and parts of rusted nails (1 of them is a complete cut nail approximately 97 mm long), 3 small pieces of melted slugs, and 10 small fragments were unearthed.



**View of the test pit after excavation**



**Colonial-era brick foundation**

### Stucco/Mortar

14 blocks of stucco/mortar were unearthed.

### Stoneware

There are quite small amount of ceramics recovered from the excavation at Test Pit 22. The stoneware shards count only seven pieces in total, which are consisting of one piece of mortar type ware (body part) and six pieces of jar (body parts). These are all small fragments and no significant specimen is included.

### Imported ceramics

Imported ceramics unearthed from the Test Pit 22 count only 23 pieces in total. There is no significant specimen to be selected for reporting. The findings are classified and counted as follows; Chinese underglazed blue and white wares during Qing dynasty: one piece of bowl (rim part), underglazed blue and white wares in modern period after 19th century : three pieces of bowl (one shard of rim part and two shards of body part), Chinese white porcelain: one piece of bowl (rim part) , Thai's under-glaze iron painted stoneware: one piece of bowl (body part) and Vietnamese underglazed blue and white ware: one piece of jar (base part)

### Earthenware

Only one piece of earthenware was recovered at the Test Pit 22 (TP22-E1). The specimen remains almost its complete form and its appearance seems like a small oil lamp. The diameter at its mouth-rim measures 5.7cm and the height of central post measures around 1.9cm from the interior bottom. The paste is light reddish ivory or pinkish beige in colour, slightly coarse with high porosity, however it is seemingly well-fired. The specimen was not manufactured by potter' s wheel but hand-made. There is no hole pierced at the top of post, while standard oil lamps of stoneware which were made in local, have commonly tall posts perforated at their top. The specimen looks just like a lamp-shaped miniature for some ceremonial or symbolic usages. However, the evidence of soot remained on the top of mouth-rim indicates clearly that the specimen was practically used as an oil lamp.



TP22-R1, R2



TP21-E1





# TEST PIT 23

Location: Near Vat Ongtu

Excavation Date: August 10, 2004

Identified Working Infrastructure(s): None

Identified Archaeological Feature(s): None

Recovered Artifacts: 851

Stoneware: 298, Earthenware: 216, Imported ceramics: 84, Bone: 98,

Stone tools: 3, Stone: 16, Brick: 68, Metal Object: 30,

Stucco/Mortar: 8, Roof Tile: 30

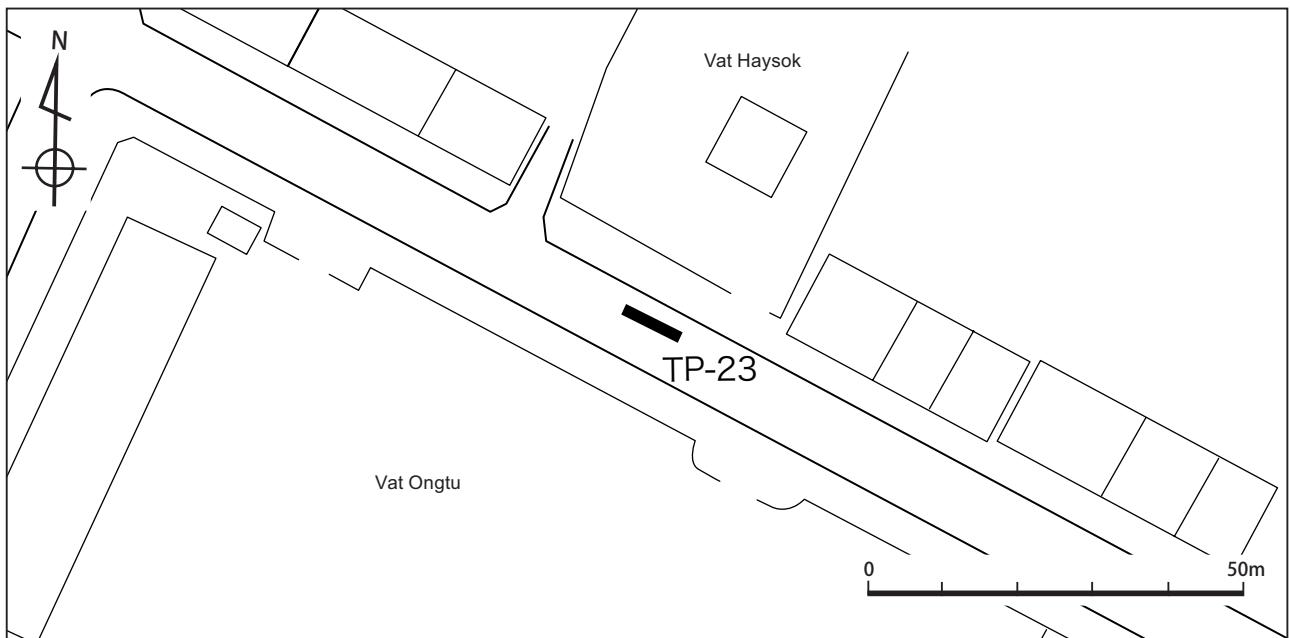
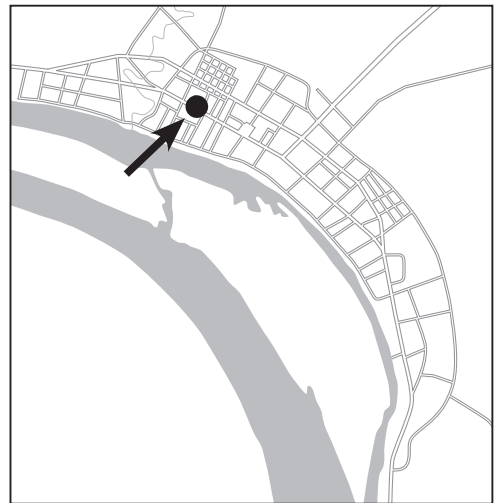

**Point E23-21**  
 Coordinates:  
 X=88,097.481  
 Y=46,272.488  
 EL=169.81m

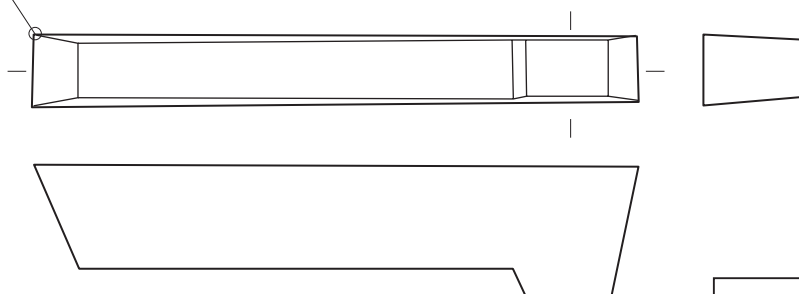

### Test Pit Dimension (max.)

Length: 8.05m

Width: 0.96m

Depth: 1.78m

Surface Area: 7.73m<sup>2</sup>

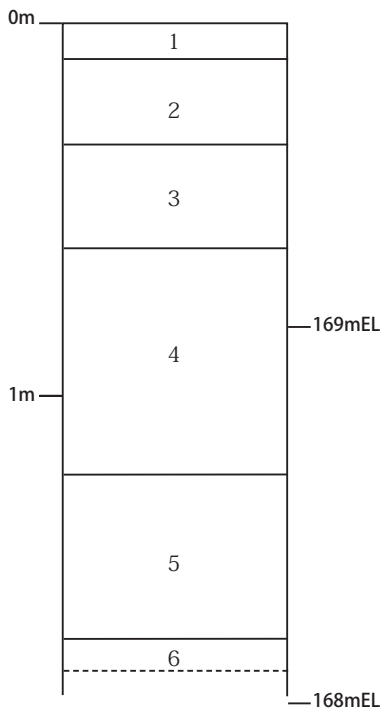

**Explanation of Soil Layers**

- 1 Asphalt: Present road surface.
- 2 Pebble/Laterite soil: Sub-base layer for the present road surface.
- 3 Dark grey-brown silt layer. Probably sub-base layer for the earlier road surface.
- 4 Dark grey silty clay. Artifacts found from this layer.
- 5 Grey silty clay: Uniform and with no inclusion.
- 6 Grey clay: Uniform and with no inclusion.



**TP23**

**Roof tiles**

30 shards of flat roof tiles were unearthed. Only 1 shard of them is fragment of thick tile (12 mm).

The trace of texture is observed on the one surface of the each of 3 shards. The thickness of these whitish and grayish shards are 8 ~ 9 mm.

Width	Thickness
97	40
103	40
110	42
117	50
117	58
117	62
118	38
121	48
122	48
125	52
128	49

**Measurements of bricks from TP23 (mm)**

**Bricks**

68 broken blocks of bricks were unearthed. Each of 11 blocks of them keeps its width and thickness (see the list below). The slugs adhere to 10 blocks.

**Metal objects**

28 pieces of melted slugs and 2 small fragments were unearthed.

**Stucco/Mortar**

8 blocks of stucco/mortar were unearthed. 1 block of them is a part of the ornaments (TP23-C1).



**Site of the excavation**



**Artifacts in situ**

## Stoneware

There are quite large amount of ceramics recovered from the excavation at Test Pit 23. The stoneware shards count 298 pieces in total, which demonstrates wide variations in shape classes, also including ash-glazed wares made in local. The findings are classified and counted in each shape class as follows; Mortar or bowl type wares: 88 pieces (28 pieces of rim part, 52 pieces of body and eight pieces of base part), bowl with incised (grating) surface on the interior: five pieces (two pieces of base part and three pieces of body part), jar type wares: 178 pieces (18 pieces of base part, 144 pieces of body part and 16 pieces of rim part), water trap jar which has a flange around the mouth to form a circular channel to reserve water as an insect barrier: one piece of rim part, lid for jar: one piece of a half part of object, oil lamp: five pieces (two pieces of central post part and three pieces of saucer part), Smoking pipe: seven pieces and ash-glazed stoneware: 12 pieces of bowl (four pieces of rim part, seven pieces of body part and one piece of base part).

TP23-S1 is a cover lid presumably accompanied with globular shaped jar. Its size measures 9.8cm in outer diameter at bottom end of the mouth rim. There are a knob at the center of cover and one lug applied on the edge of cover in horizontal angle.

TP23-S2 is a rim part of ash-glazed bowl. There are impressed decorations of a set of triangles and lines on the exterior. Its glaze is light greenish grey in colour, opaque but partially shiny covering whole the remained part.

TP23-S3 are smoking pipes, two pieces of which are stem parts, other two pieces are stem to body parts and the remaining three pieces are bowl parts. The specimens have common texture of clay is relatively fine grained, while they varies in colour from greyish white through a range of greys to black, probably depending on their locations in the kiln or their fired condition. There are fine molded decorations on their exterior.

## Imported ceramics

There are quite many pieces of imported ceramics unearthed from the Test Pit 23, which count 84 pieces in total. The findings show wide variations in their origin and dating. The specimens are classified and counted as follows; Chinese underglazed blue and white wares in later Qing dynasty and modern period after 19th century: 37 pieces of bowl (13 shards of rim part, 20 shards of body part and four shards of base part), three pieces of plate or basin (two pieces of rim part and one piece of body part), Chinese white porcelain: two pieces of bowl (body parts) and one piece of plate (body part), Chinese over glaze enamel painted wares in later Qing dynasty and its after (modern period): three pieces of bowl (two shards of rim part and one piece of body part), three pieces of small jar or bottle typed wares (body parts) and one piece of round box body, Thai's celadon glazed stoneware around 15th century: two pieces of bowl (one shard of rim part and one shard of body part), three pieces of plate (one shard of body part and two shards of rim part) and five pieces of small jar or bottle (body part), Thai's underglaze iron painted ware: two pieces of bowl (one shard of rim part and one shard of body part) which was probably fired at Kalong kiln groups during 14th to mid-16th centuries, Thai's brown glazed stoneware: seven pieces of large jar (body part), Vietnamese underglazed blue and white ware: two pieces of bowl (one shard of body part and one shard of base part which is so-called "chocolate bottom"), Vietnamese over-glaze enamel painted ware: three pieces of bowl (one shard of rim, one shard of body and one shard of base part), Underglazed iron painted ware: one piece of bowl (rim part), Japanese underglazed blue and white porcelain: three pieces of bowl (body parts) and one piece of lid or cover for box ware, which were possibly manufactured in Hizen kilns during the latter half of 19th century, and Japanese underglazed blue and white porcelain with over-glaze enamel decoration: two pieces of bowl (one piece of rim and one piece of body part), which were possibly manufactured in Hizen kilns at the beginning of 19th century.

TP23-I1 is a body part of bowl of Thai's under-glaze iron painted stoneware. Its paste is light brown in colour, solid but quite coarse including white particles. There are decorations painting a set of spur marks on the inner wall and a solar whorl or discus (so-called "chakra") motif on the interior bottom. From these characteristic design of decorations, the specimen can be identified as a kind of Sukhothai wares manufactured in 14th to 15th centuries.

TP23 I2 is a rim part of under-glaze iron painted stoneware bowl. Its size can be estimated 14.6cm in diameter at the top pf mouth-rim. The paste is light greyish beige in colour, relatively fine and solid. There is a decoration painting a solar whorl or a sun-flower motif remained on the exterior wall. This motif of iron painted decors is quite popular among Thai and also Vietnamese wares through 14th to 15th centuries, while the specimen can be supposed to be



made in Vietnam.

### Earthenware

There are comparatively many shards of earthenware recovered at the Test Pit 23, which count 216 pieces in total. The shards of rim parts counting 38 pieces present similar variations and tendencies in their shape-classes to the contents of findings at TP11. Namely as mentioned above, major specimens can be identified as large jars which have nearly straight-standing neck part with protruded (thickened) mouth-rim. Among rim shards of jar typed wares except for these straight-standing type, only three shards have flared mouths with outward-inclined profiles. Other few rim shards (in fact, only two pieces) shows outward angled shape with small protruded edge as shown in the photo plate. These rim types may be attached to shallow bowls.

As other kinds of earthenware, there are six pieces with impressed decorations of short oblique lines or cross stripes motifs also recovered, which are introduced in the photo plates.

On the other hand, it should be noted that considerable numbers (57 pieces) of possibly newer-dated earthenware with fine-grained paste and quite thinner body walls were recovered from TP23. The findings seems to be classified into two groups in accordance simply with colour and texture of paste as follows;

Type-A: Light orange coloured, very fine-grained paste type with red-painted surface.

Type-B: Light greyish brown coloured and slightly coarse-grained paste type with carbon-blackened (polished?) surface.

The following specimens are shown in the photo plate as standards of each type.

Type-A: Oil lamp (?); two pieces of probable oil lamps which consist of long stem part and small dish part. While they present different form from the oil lamps of stoneware.

Jar typed ware; one piece of base part of large jar or bottle

Type-B: Pitcher or "Kendi" typed ware; one piece of spout part and one piece of possible rim part which have different texture of paste from the other "Kendi" ware recovered at TP11 (see the section of TP11)

Jar typed ware; one piece of base part and one piece of neck to shoulder part which has impressed decoration of fine oblique lines.





TP23-11



TP23-12



Earthenware pieces from TP23 (1)



Earthenware pieces from TP23 (2)



Earthenware pieces from TP23 (3)



# TEST PIT 24

Location: Near Vat Mixay.

Excavation Date: August 11th, 2004

Identified Working Infrastructure(s): None

Identified Archaeological Feature(s): None

Recovered Artifacts: 1272

Stoneware: 100, Earthenware: 216, Imported ceramics: 84, Bone: 98,

Stone tools: 3, Stone: 16, Brick: 68, Metal Object: 30,

Stucco/Mortar: 8, Roof Tile: 30

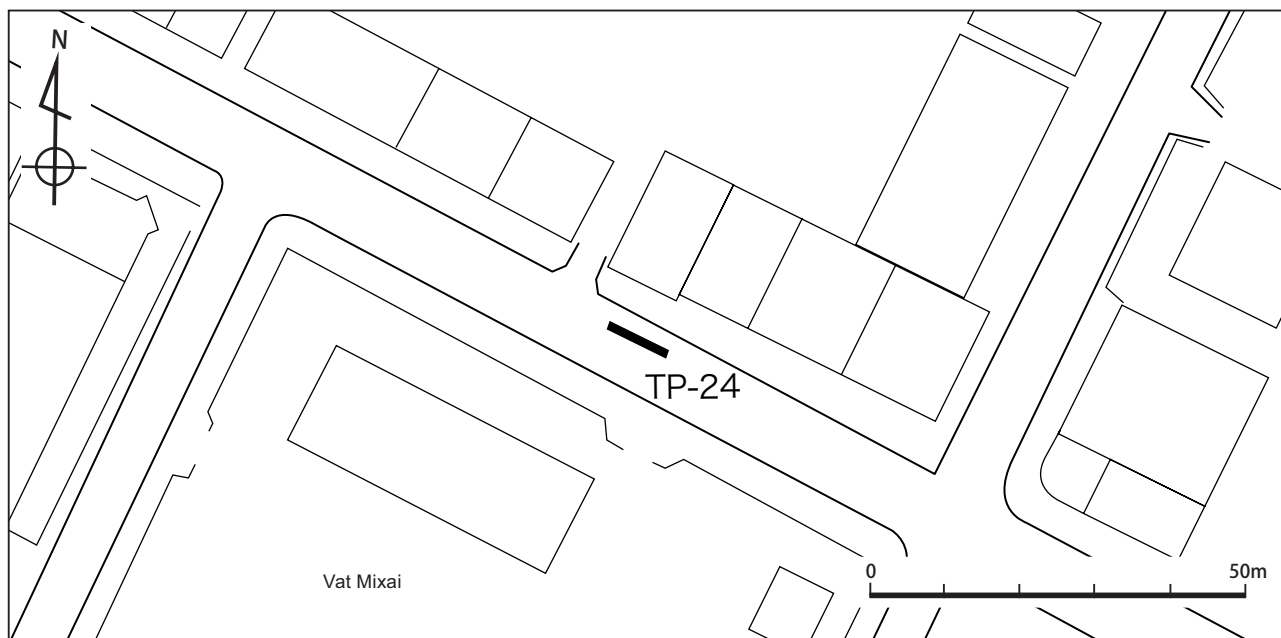
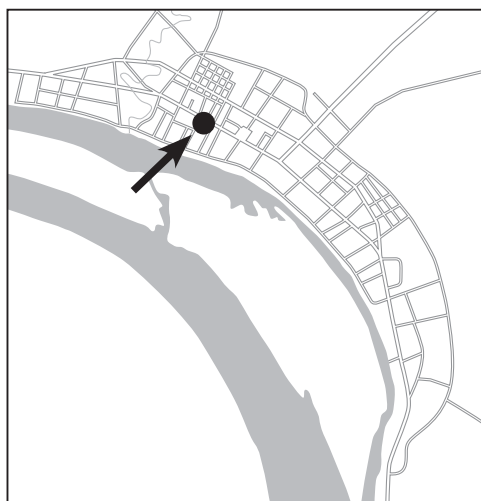

**Point E24-17**  
Coordinates:  
X=88,027.560  
Y=46,404.693  
EL=169.90m

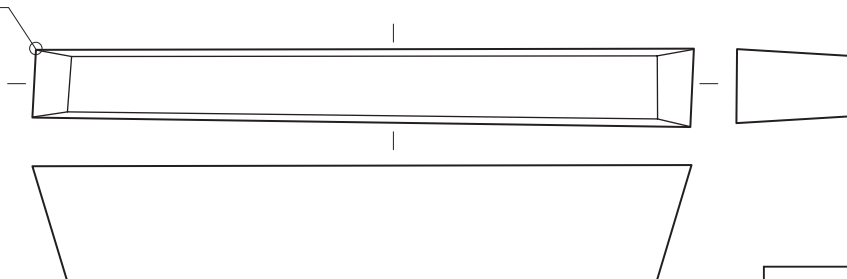

### Test Pit Dimention (max.)

Length: 8.78m

Width: 1.02m

Depth: 1.55m

Area: 8.96m<sup>2</sup>

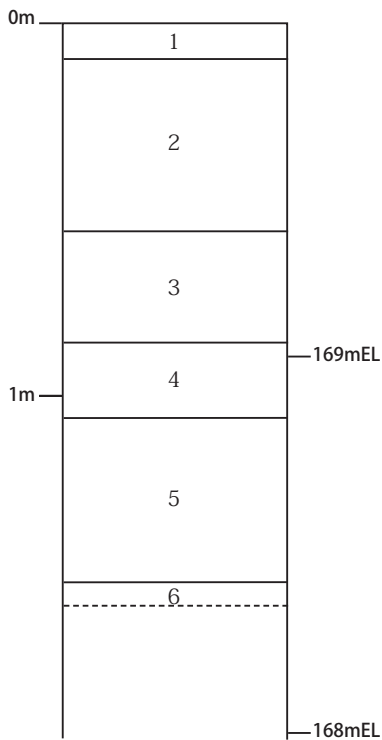

**Explanation of Soil Layers**

- 1 Asphalt: Present road surface.
- 2 Pebble/Laterite soil: Sub-base layer for the present road surface.
- 3 Dark grey-brown silt layer. Probably sub-base layer for the earlier road surface.
- 4 Dark grey silty clay. Artifacts found from this layer.
- 5 Grey silty clay: Uniform and with no inclusion.
- 6 Grey clay: Uniform and with no inclusion.



**Artifacts**

**Roof tiles**

769 shards of thin flat roof tiles were unearthed. Each 3 shards of them keeps its full width (see table at the right, TP24-R1 to R3).

Width	Thickness	Remarks
120	6	A part of front end
120	6	A part of rear end with stopper
134	6	A part of rear end with stopper

**Measurements of roof tiles from TP24 (mm)**

Length	Width	Thickness	Remarks
	100	44	
	100	46	
	101	44	
	104	46	
	106	47	
	110	44	
	110	44	
	111	48	
	111	55	
	112	43	
233	114	43	mortar adheres
	114	43	
	115	58	
	118	59	
	119	43	
	154	58	

**Measurements of bricks from TP24 (mm)**

**Bricks**

One piece of brick, which keeps its original length, width, and thickness, and 77 broken blocks were unearthed. Each of 15 blocks of them keeps its width and thickness only (see table at the right). The slugs adhere to 2 blocks.

**Metal objects**

Four complete and parts of rusted nails (the longest one is a cut nail approximately 195 mm long), 11 pieces of melted slugs, and 1 part of the furniture fitting (?) were unearthed.



**View of the test pit after excavation**



**Colonial-era brick foundation**



## Stucco/Mortar

27 blocks of stucco/mortar were unearthed. 7 blocks of them may be parts of the moldings. 1 block includes a fragment of brick or roof tile.

## Stoneware

There are relatively large amount of ceramics recovered from the excavation at Test Pit 24. The stoneware shards count 100 pieces in total. The findings are classified and counted in each shape class as follows; mortar or bowl type wares: 15 pieces (six pieces of rim part, seven pieces of body and two pieces of base part), jar type wares: 73 pieces (17 pieces of base part, 55 pieces of body part and one piece of rim part), lug for jar: two pieces, oil lamp: one piece, smoking pipe: seven pieces, fish net weight: one piece and ash-glazed stoneware: one piece of jar with vertical grooves (base part)

TP24-S1 is a base to body part of jar with wide mouth-rim. It shows a typical proportion among the local-made stoneware. Its size measures 11.2cm in diameter at the bottom end of base. The paste is light grey in colour, sandy or coarse grained. There is no decoration, glaze or natural fly-ash observed on the remained part.

TP24-S2 is a cylindrical lumps of clay with hole along its axis, which is commonly assumed to be a weight for fish net. Its sizes measure as follows: 3.6cm in full length, 2.35cm in outer diameter at the widest point and 1.0cm in diameter of the hole. The paste is relatively fine grained, while including mica particles. Its outer surface is dark grey in colour.

TP24-S3-S9 are parts of smoking pipes. Except for one piece of bowl part, other six pieces are stem part or stem to body part. The specimens varies in shape, design of decors and especially in colour from greyish white through a range of greys to black, and there is also including the light orange coloured piece. The specimen with light orange in colour has clearly different paste (quite finer than others) and proportion. It seems to be manufactured in some other areas or provinces, while other greyish coloured types are understood to be made in local (inside or around of the present Vientiane city area).

## Imported ceramics

There are quite many pieces of imported ceramics unearthed from the Test Pit 24, which count 37 pieces in total. The specimens are classified and counted as follows; Chinese underglazed blue and white wares in later Qing dynasty and modern period after 19th century: 17 pieces of bowl (four shards of rim part and 13 shards of body part) and three pieces of plate or basin (body parts), Chinese white porcelain including the older products during Yuan or early Ming dynasties: four pieces of bowl (one shard of rim, one shard of body and two shards of base parts) and two pieces of small jar or bottle (one shard of rim and one shard of base part), Chinese over glaze red-enamel painted wares in later Qing dynasty and its after (modern period): three pieces of bowl (two shards of base part and one piece of body part), one piece of plate or basin (base part), Thai's celadon glazed stoneware around 15th century: one piece of plate (body part), Thai's brown glazed stoneware: one piece of large jar (body part), Vietnamese underglazed blue and white ware: three pieces of bowl (base part) and Japanese underglazed blue and white porcelain: two pieces of bowl (one shard of rim and one shard of body part).

TP24-I1 is a base part of Vietnamese underglazed blue and white bowl. Its size measures 4.8cm in outer diameter at the bottom end of foot-ring. The paste is light beige or light brownish white in colour, quite coarse and bumpy. There are dark indigo-blue coloured decorations painting plants or some other abstract motifs in running touch on the exterior wall and interior bottom. The glaze is pale white in colour, opaque with many cracks occurred in the glaze. On the exterior bottom inside the foot-ring, there seems to be once painted in reddish brown. The paints has been almost faded out now, but it should be a so-called "chocolate base" which is common or popular technique among Vietnamese products during 16th to the early 17th centuries.

TP24-I2 is a base part of Chinese white porcelain. Its size measures 6.3cm in diameter at the inner bottom end of foot-ring. The paste is creamy white, slightly crumbly but solid. The glaze presents light greyish coloured, almost transparent and shiny. Around the interior bottom, the glaze is wiped off in circular ring shape. The specimen can be identified to manufactured in Southern China during the later Yuan or early Ming dynasties (14th to 15th centuries), as

far as considering about characteristics of its shape, paste and glaze.

TP24-I3 and I4 are small bowls of Japanese underglazed blue and white porcelain. I3 is a rim part and I4 is a body part, which are two different wares. Both have quite fine-grained and solid pastes of almost pure white in colour, which present the characteristics of paste common to Japan products. The under-glaze decoration of I3 paints trees or some other motifs in light greyish blue, while the decors of I3 paints a chrysanthemum flower in dark blue colour. Both specimens were possibly manufactured in Hizen kilns in Western Japan during the latter half of 19th century.

#### Earthenware

There are 77 shards of earthenware recovered at the Test Pit 24. The shards of rim parts counting 19 pieces vary in their shape classes, namely there are mixed several kinds of proportions such as straight-standing types, flared or outward angled mouth types (both of which are rims of jar typed wares) and gently curved types (which are rims of not jar but bowl or mortar type wares). Each type of rim part, however, may be almost common to the standard specimen from other Test Pits. One specimen of rim part shown in the photo plate has a slightly peculiar shape in profile. Its angle inclined to outward is deeper than other standard types and its end of mouth-rim is protruded more strongly. Besides, the paste of specimen seems to include much more mica particles than other general earthenware.

Except for the vessels mentioned above, there are nine pieces of oil lamp unearthed, which consist of five pieces of rim part, four pieces of base part (some of which are shown in the photo plate). All the pieces seem to be same type as the specimen recovered at TP22.

As other kinds of earthenware, there are four pieces with impressed decorations of short oblique lines or herringbone like motifs also recovered. Another one specimen, which is a neck to shoulder part of jar typed ware also exists pricked decorations of circumferential dotted lines, as shown in the photo plate. However its technique and motif are completely different from above-mentioned four pieces or the findings from other Test Pit s. Its paste which is light reddish ivory or pinkish beige in colour and fine-grained, is also peculiar nature. The specimen seems to be dated comparatively newer period or nearly modern period, but it is unidentified exactly.



TP24-R1 to R3

10cm



TP24-S1



TP24-S2



TP24-S3



TP24-I1

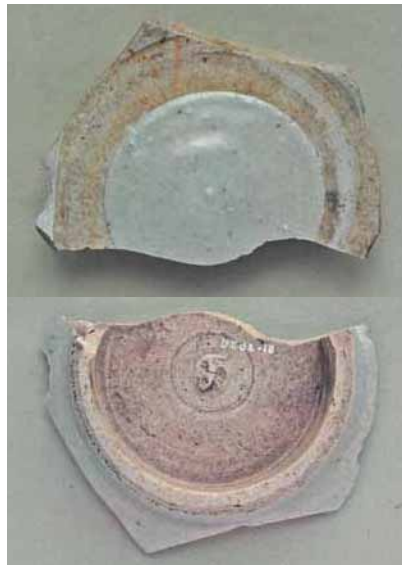

TP24-I2



TP24-I3, I4



Earthenware pieces from TP24



# TEST PIT 25

Location: Near Lao News Agency.

Excavation Date: August 12th, 2004

Identified Working Infrastructure(s): None

Identified Archaeological Feature(s): None

Recovered Artifacts: 554.

Stoneware: 253, Earthenware: 78, Imported ceramics: 73, Bone: 114,

Stone tools: 2, Stone: 7, Brick: 21, Metal Object: 3, Roof Tile: 3

Note: Near the range of presently non-existent Vat Sibunyuon.

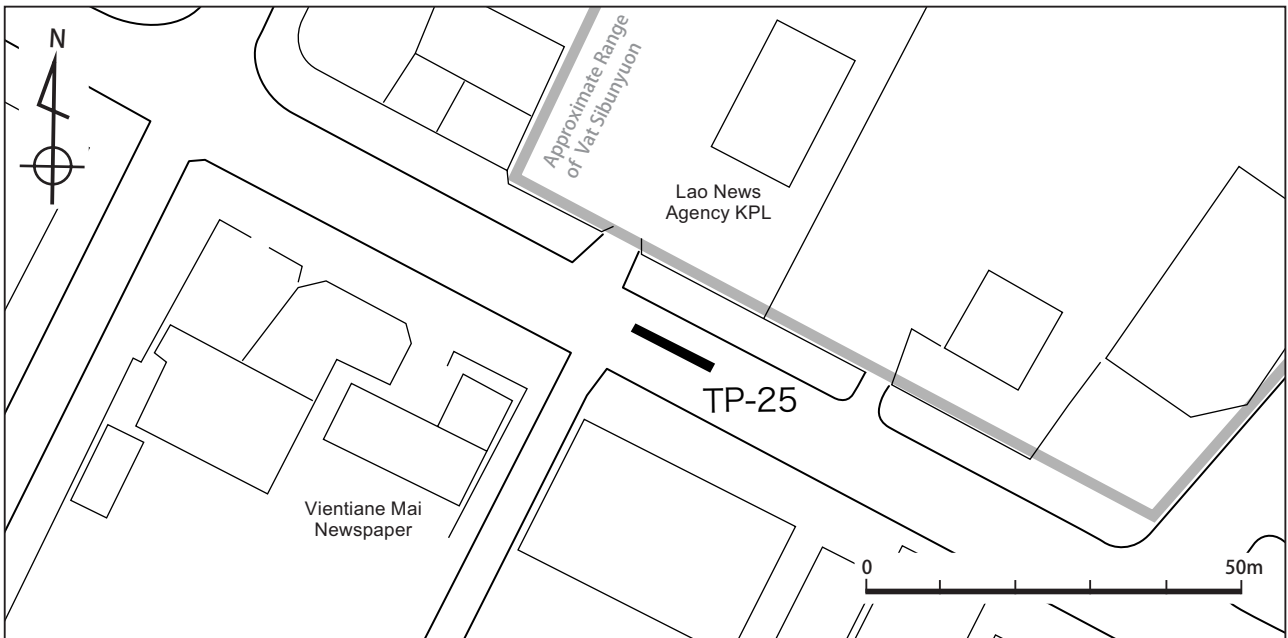
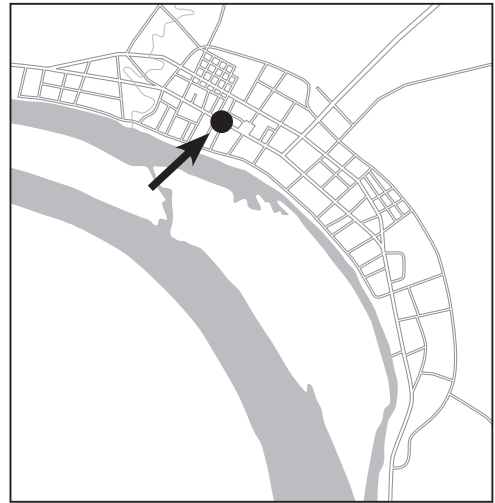

**Point E25-17**

Coordinates:

X=87,939.931

Y=46,567.009

EL=170.15m

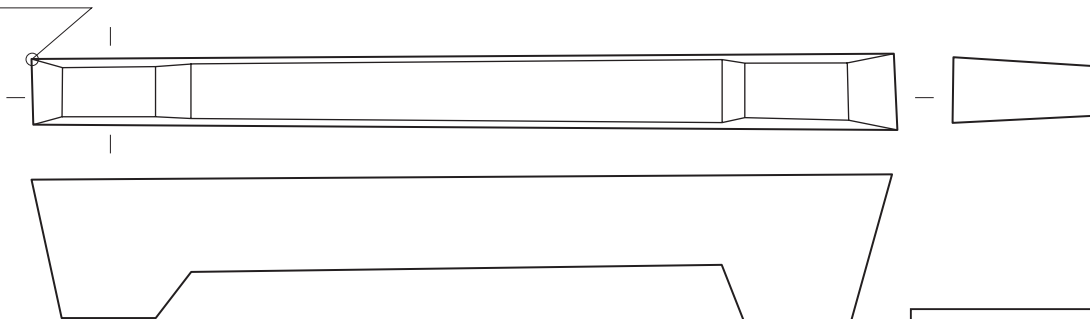

Test Pit Dimention (max.)
Length: 11.50m
Width: 0.99m
Depth: 2.02m
Surface Area: 11.39m <sup>2</sup>



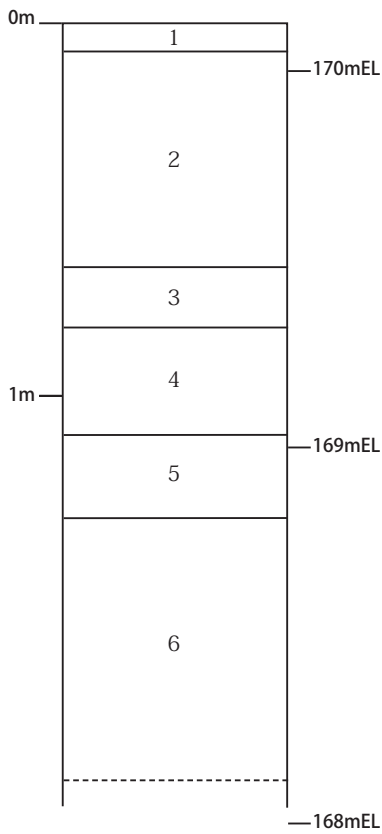

**Explanation of Soil Layers**

- 1 Asphalt: Present road surface.
- 2 Pebble/Laterite soil: Sub-base layer for the present road surface.
- 3 Dark grey-brown silt layer. Probably sub-base layer for the earlier road surface.
- 4 Dark grey silty clay. Artifacts found from this layer.
- 5 Grey silty clay: Uniform and with no inclusion.
- 6 Grey clay: Uniform and with no inclusion. Easily collapsible when exposed.



**Artifacts**

**Roof tiles**

Only 3 shards of thin flat roof tiles were unearthed.

Width	Thickness
90	39

Measurements of a brick from TP25 (mm)

**Bricks**

21 broken blocks of bricks were unearthed. 1 block of them keeps its width and thickness (see table above).

**Metal objects**

1 rusted nail approximately 98 mm long, and 2 pieces of melted slugs were unearthed.

**Stoneware**

There are profuse amount of ceramics recovered from the excavation at Test Pit 25. The stoneware shards count 253 pieces in total. The findings are classified and counted in each shape class as follows; mortar or bowl type wares: 33 pieces (15 shards of rim part, ten shards of body and eight shards of base part), stem bowl: one piece (stem part)



View of the test pit after excavation



Colonial-era brick foundation

Jar or bottle type wares: 212 pieces (20 shards of base part, 182 shards of body part and ten shards of rim part) of large jar fragments and one piece of a small bottle, oil lamp: one piece, smoking pipe: three pieces, and sh-glazed stoneware: four pieces of bowl (three shards of rim part and one shard of base part)

TP25-S1 is a small bottle, which remains almost complete form except for the top end of rim part. Its sizes measure 5.1cm in diameter at the bottom, 7.0cm in diameter at the widest point of body and 7.5cm in height at the remained part. The paste is dark grey in colour, comparatively fine and solid. There are natural fly-ash exist partially on the shoulder. The trace of cord-cut marks is clearly remained on the exterior bottom. The striation lines are straight and parallel, indicating a cut made while the potter's wheel was stationary.

TP25-S2-S4 are smoking pipes, consisting of one piece of stem to body part, one piece of body to bowl part and one piece of the mouth-rim of bowl part. The specimens have common paste which is light grey in colour, fine grained but slightly bumpy with some pores, while the colours appeared on each surface vary from near white through a range of greys to near black, that indicates differences of individual position and condition in kilns during firing. There are molded and incised decorations on the surfaces of body to bowl parts, which are general motifs used commonly in stoneware pipes fired in local.

TP25-S5 is a base part of ash-glazed stoneware bowl, which has a trimmed base with foot-ring and is glazed all over, including the well (inside) of the base. its size measures around 6.0cm in outer diameter at the bottom end of foot-ring. The paste is dark grey in colour, comparatively coarse but solid. There is no decoration on the remained base part. The glaze is light greyish green or light olive green in colour, thin applied, translucent and shiny partially. There are considerable substances or burnt vegetable matter (rice husk or straw?) stuck on the glaze at the interior bottom, which could be supposed to be used for stacking wares up in kilns to protect them from sticking with each other during firing.

#### Imported ceramics

There are relatively many pieces of imported ceramics unearthed from the Test Pit 25, which count 73 pieces in total. The specimens demonstrate wide variations in their origins and production periods, which are classified and counted as follows; Chinese celadon in probably Yuan or early Ming dynasties: one piece of bowl (body part) and one piece of plate or basin (base part), Chinese underglazed blue and white wares in later Qing dynasty: 21 pieces of bowl (three shards of rim part, 16 shards of body part and two shards of base part) and one piece of lid for jar (body parts), Chinese white porcelain: three pieces of bowl (one shard of body and two shards of base parts) and one piece of plate (base part), Chinese over glaze red-enamel painted wares in later Qing dynasty and its after (modern period): four pieces of bowl (two shards of base part and two shards of body part) and one piece of round box cover (body part), Thai's celadon glazed stoneware around 15th century: one piece of bowl (base part) and eight pieces of plate or basin (two shards of rim part, four shards of body part and two shards of base part), Thai's underglaze iron painted ware: five pieces of bowl (base part) and two pieces of plate or basin (base part), Thai's brown glazed stoneware: 17 pieces of large jar (one shard of rim and 16 shards of body part), Vietnamese underglazed blue and white ware: two pieces of bowl (body parts), Vietnamese over-glaze enamel painted ware: one piece of bowl (four shards of base part adjoined with each other composing one piece), and Japanese underglazed blue and white porcelain with over-glaze enamel decors: one piece of bowl (rim part).

TP25-I1 is a base part of Chinese white porcelain, which has a trimmed base with small foot-ring. Its size measures 4.6cm in diameter at the bottom end of foot-ring. The paste is light grayish white in colour, quite fine and solid. There is no decoration on the remained base part. The glaze is pale coloured, transparent and very shiny. It is glazed almost all over including the well of exterior bottom inside the foot-ring. The specimen can be categorized as a so-called "Qing-pai" or bluish-white ware, which was manufactured extensively in Jindezhen kiln groups of Southern China for centuries since Northern Sung until Yuan dynasties. The specimen still has relatively high qualities, however it is identified to be one of the mass-products for exporting to all over the East and Southeast Asia, during Southern Sung or early Yuan dynasties (13th to 14th centuries).

TP25-I2 is a base part of Vietnamese over-glaze enamel painted ware. It has a small foot-ring measured 8.5cm in its outer diameter. The paste is greyish beige, slightly coarse and crumbly. There are enamel decorations painting a flower

with stem and leaves in dark red and some dotted motifs in bright green, which has been faded out partially. The exterior bottom inside the foot-ring seems to have been painted in iron red or so-called "chocolate base", which has also faded out now. The specimen probably dates around 16th century.

TP25-I3 is a base part of Thai's underglaze iron painted bowl with shallow foot-ring. Its size measures 7.5cm in outer diameter at bottom end of the foot-ring. The paste is greyish cream coloured, rather coarse and bumpy with many pores. There are under-glaze decorations of circular motifs are painted in greenish grey to black colour. The specimen was probably manufactured at some kiln in Northern Thai during 15th to 16th centuries.

### Earthenware

There are 78 shards of earthenware recovered at the Test Pit 25. The shapes of rim parts counting 10 pieces are almost limited to one class; the straight-standing type with small protruded edge. As other kinds of earthenware, there are two pieces with impressed decorations of short oblique lines or herringbone like motifs also recovered. As similar to the proportional composition at TP23, it is remarkable that there were unearthed 21 pieces of the fine-grained types of earthenware, which may be dated in the newer period. In the photo plate, two pieces of jar or "Kendi" type wares with red painted surface (above-mentioned Type-A, see the section of TP23 for detail) and one base part of large jar with blackened surface (Type-B; ditto) are shown as typical findings.



TP25-S1



TP25-S2, S3



TP25-S4



TP25-S5



TP25-I1



TP25-I2



Earthenware pieces from TP25



TP25-I3



# Test Pit 26

Location: Near National Library.

Excavation Date: August 13th, 2004

Identified Working Infrastructure(s): None

Identified Archaeological Feature(s): None

Recovered Artifacts: 1272

Stoneware: 414, Earthenware: 344, Imported ceramics: 175,  
 Bone: 69, Stone: 16, Brick: 53, Metal Object: 14, Stucco/Mortar: 14,  
 Roof Tile: 305

Note: Near the range of presently non-existent Vat Pakhao.

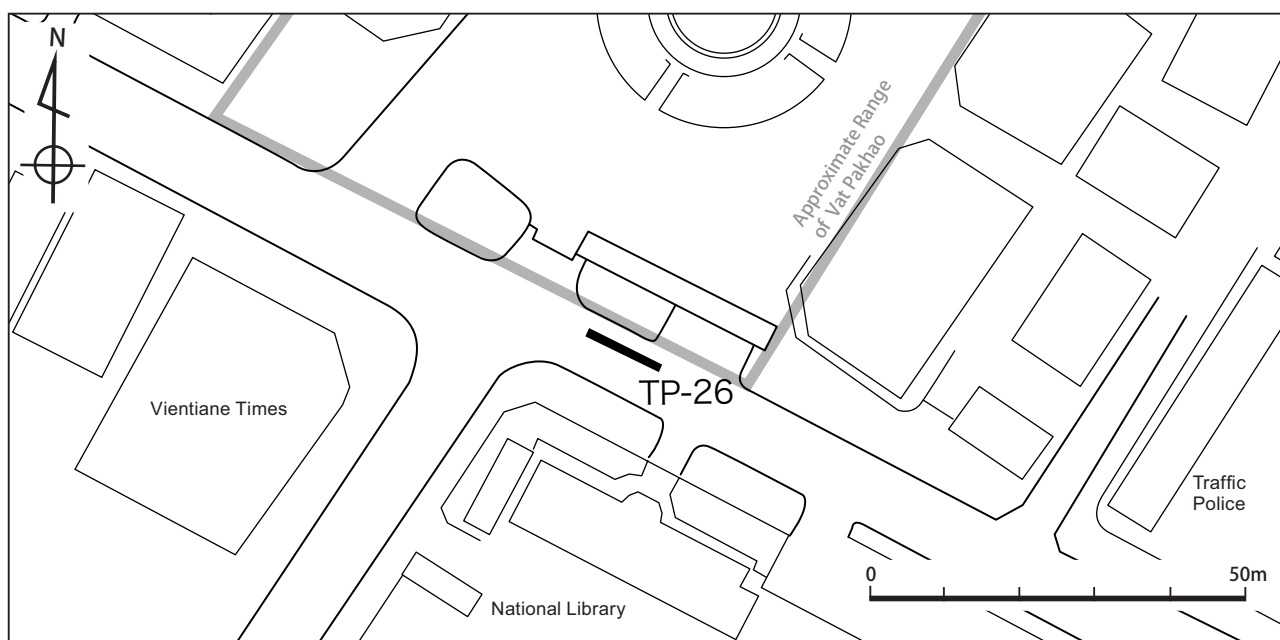
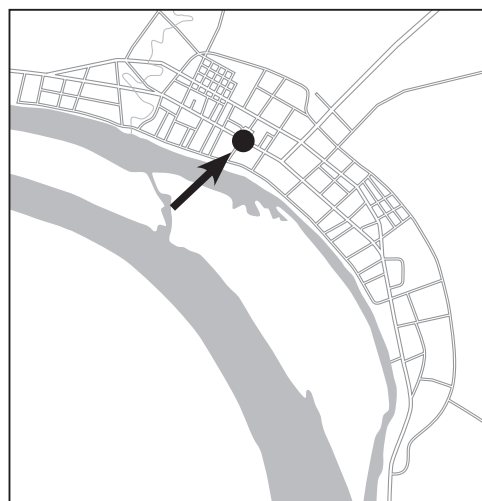

**Point E26-34**  
 Coordinates:  
 X=87,889.322  
 Y=46,668.372  
 EL=170.32m

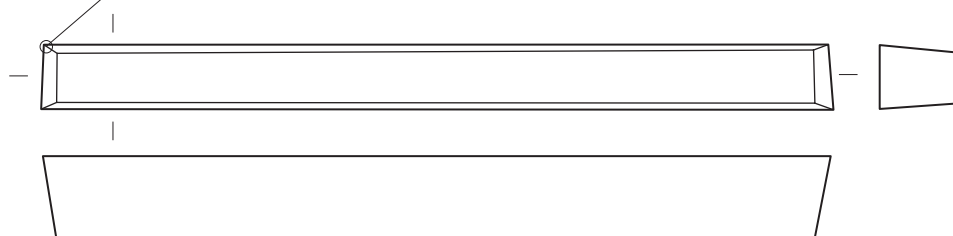

### Test Pit Dimention (max.)

Length: 10.52m

Width: 0.88m

Depth: 1.4m

Surface Area: 9.26m<sup>2</sup>



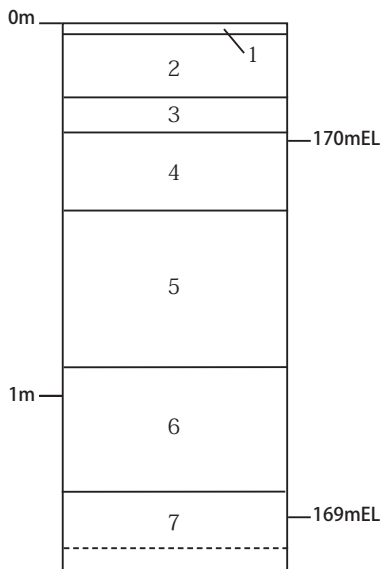

Explanation of Soil Layers	
1	Asphalt: Present road surface.
2	Pebble/Laterite soil: Sub-base layer for the present road surface.
3	Compacted bricks: Earlier pavement?
4	Dark grey-brown silt layer. Probably sub-base layer for the earlier road surface.
5	Dark grey silty clay. Artifacts found from this layer.
6	Grey silty clay: Uniform and with no inclusion.
7	Grey clay: Uniform and with no inclusion.



**Artifacts**

**Roof tiles**

302 shards of thin flat roof tiles and 3 shards of half-round ones(?) were unearthed.

The trace of texture is observed on the one surface of the each of 10 shards including half-round ones. The thickness of these whitish and reddish shards are 6 to 11 mm.

**Bricks**

53 broken blocks of bricks were unearthed. Each of 6 blocks of them keeps its width and thickness (see table). The natural glaze are on the surfaces partly of other 7 blocks.

Width	Thickness
97	55
115	58
115	58
121	39
122	47
130	53

Measurements of a brick from TP26 (mm)

**Metal objects**

4 parts of rusted nails (a shard of roof tiles sticks to each of 2 nails of them), 1 piece of rusted wire, 8 small pieces of melted slugs which may have a relation to the detected kiln in the compound of present National Library, and 1 small fragment were unearthed.

**Stucco/Mortar**

14 blocks of stucco/mortar were unearthed. 1 of them is a corner part with molding of the structure (TP26-C1).



View of the Test Pit after excavation



Colonial-era brick foundation

## Stoneware

There are extremely profuse amount of ceramics recovered from the excavation at Test Pit 26. The stoneware shards count 414 pieces in total, which is the secondary large number (next to the quantity unearthed at the TP02) through a series of the excavations at the TP01~32. The findings demonstrate quite wide variations. Especially, it should be noted that relatively many pieces (48 shards) of ash-glazed wares are recovered. While, the contents of shape classes of the unglazed ordinal stoneware seem to be almost common to the findings from other test pits.

On the other hand, they also include some specimens which could be regarded as production waste, under-fired or sub-standard articles as reported below. It indicates that the area around the TP26 was possibly to be a site of pottery production kilns as similar to the another kiln site where the TP02 was located. In fact, it has been understood that the location of TP26 or the north side area of National Library could be a kiln site or at least a site with big deposits of pottery, according to the several sources or documents.

The findings are classified and counted in each shape class as follows; mortar or bowl type wares: 67 pieces (21 shards of rim part, 31 shards of body and 15 shards of base part), stem bowl: one piece (stem part), bowl with an incised or grating surface on the interior: ten pieces (five shards of rim part, three shards of body and two shards of base part), jar or bottle type wares: 257 pieces (26 shards of base part, 210 shards of body part and 21 shards of rim part), lid for globular jar: one piece (body part), oil lamp: six pieces (four shards of the center post part and two shards of the saucer part), smoking pipe: 24 pieces (15 pieces of the stem to body parts and nine pieces of the bowl parts), ash-glazed bowl: 31 pieces (nine shards of rim part, 15 shards of body part and seven shards of base part), ash-glazed bowl with vertical grooves decoration: 11 pieces (one piece of rim to base part, seven shards of body part and three shards of base part), and ash-glazed jar or bottle: three pieces (all base parts).

TP26-S1 is a base part of ash-glazed bowl which has trimmed base with tall foot-ring. Its size measures 8.1cm in at outer diameter at the bottom end of the foot-ring, a relatively large sized ware as a bowl. The paste is dark grey in colour, solid but quite coarse with pores. There are long cracks occurred crossing the exterior base. The glaze is light greenish grey in colour, translucent and partially shiny. There is no glaze on the interior and exterior bottom.

TP26-S2 is a base part of ash-glazed bowl which has trimmed base with small foot-ring. Its estimated size measures 6.2cm in outer diameter at the bottom end of the foot-ring. The paste is dark brownish grey in colour, solid but quite coarse with pores and cracks. Its glaze is light greenish grey in colour, opaque and no shine. There is glazed all over the remained part including the bottom end of foot-ring. It is notable that one small tetra-pod shaped nugget of clay is stuck on the inside of foot-ring. The nugget presents light greyish orange in colour, which is different colour from the body paste of specimen itself. It seems to be used as a kind of supporting tool in the kiln for stacking wares not to be contacted directly with each other during firing. If so, it is considerable that the specimen was deposited as sub-standard articles at the time of forwarding (output) products from kilns, that is, there should be kilns firing ash-glazed wares in the neighborhood of the test pit.

TP26-S3 is rim parts of ash-glazed bowls found in three fragments. All the specimens have impressed decorations of triangle (or arrowhead-like) motifs separated by incised, circumferential lines. The pastes are dark grey in colour, solid but slightly coarse. It is covered by light greyish green, translucent and shiny glaze.

TP26-S4 is a rim to base parts of ash-glazed bowl (or cup) with vertical grooves decoration on the exterior. Its estimated sizes measure 10.8cm in diameter at mouth-rim and 5.8cm in height. The paste is dark grey in colour, solid but slightly coarse with pores. Its glaze is light greyish green (light olive) in colour, translucent and shiny. There are glazed all over the remained part. There are some substances or burnt vegetable matter (rice husk or straw?) stuck on the glaze at the exterior bottom.

TP26-S5 is a base part of ash-glazed jar or bottle. Its exterior bottom was not trimmed as the striations evident (the code-cut marks) remained clearly. Its estimated sizes measure 12.8cm in diameter at bottom end. The paste is dark grey in colour, solid but relatively coarse with many pores. Its glaze is light greyish green (light olive) in colour, very thin-layered, translucent and shiny. There is no glaze on interior and exterior bottom. There are incised circumferential lines running horizontally near the bottom end. The specimen is only one finding of jar shaped ware with ash glaze, among all the stoneware shards recovered from the excavations at 32 test pits.

## Imported ceramics

There are the greatest number of imported ceramics unearthed from the Test Pit 26, which count 175 pieces in total. The specimens demonstrate wide variations in their origins and production periods, which are classified and counted as follows; Chinese celadon in probably Yuan to early Ming dynasties: five pieces of bowl (three shards of rim part, one shard of body part and one shard of base part), Chinese underglazed blue and white wares in later Ming to early Qing dynasties: two pieces of bowl (body parts), one piece of basin (base part) and two pieces jar (body parts), Chinese underglazed blue and white wares in Qing dynasty and its after: 102 pieces of bowl (two pieces of rim to base part, 28 shards of rim part, 53 shards of body part and 19 shards of base part), three pieces of dish (two shards of rim part and one shard of body part), three pieces of basin or plate (body parts), two pieces of lid for jar or some other vessel (body parts) and two pieces of round box (cover part), Chinese white porcelain: eight pieces of bowl (two shards of rim part, four shards of body and two shards of base parts), two pieces of lid for jar and two pieces of round box (one shard of cover and one shard of body part), Chinese over glaze red-enamel painted wares in later Qing dynasty to modern period: six pieces of bowl (two shards of rim part and four shards of body part), one piece of plate (body part), one piece of small jar (body part) and two piece of lid for vessel (body parts), Thai's celadon glazed stoneware around 15th century: one piece of bowl (base part) Thai's brown glazed stoneware: three pieces of large jar (body parts), Vietnamese underglazed blue and white ware: 14 pieces of bowl (one piece of rim to base part, four shards of rim part, six shards of body part and three pieces of base part), Vietnamese over-glaze enamel painted ware: three pieces of bowl (one shard of rim and two shards of body part), Vietnamese under-glaze iron painted ware: one piece of bowl (body part) and one piece of plate (rim part), Japanese underglazed blue and white porcelain: two pieces of bowl (rim parts) and one piece of plate (base part)

TP26-I1 is a rim part of Chinese celadon bowl. Its estimated size measures around 14cm in diameter at the top end of mouth-rim. The paste is light grey in colour, fine and solid. The glaze is light greenish grey in colour, slightly opaque with small bubbles and shiny. It can be understood that the paste and glaze of specimen present characteristics of Chinese celadon manufactured in Lungchuan kilns during around Yuan dynasty (the latter half of 14th to 15th centuries).

TP26-I2 is a cover part of round box of Chinese white porcelain. The round box ware consist of nearly same sized cover part and body part, which had been a peculiar small vessel to Chinese ware for centuries, probably used as a container for incense or medicine. The paste is nearly white in colour, very fine and solid. The glaze is light pale white in colour, translucent and very shiny. The specimen was probably made in Jindezhen kiln groups during Southern Sung or early Yuan dynasties (the late of 13th to 14th centuries).

## Earthenware

There are comparatively large amount of earthenware recovered at the Test Pit 26, which count 344 pieces in total. The shards of rim parts counting 54 pieces presents wide variations which could be divided into four or five classes. Each shape-class is, however, almost common to the finds from other Test Pit s such as TP11 or TP18. Four specimens existing typical forms are shown in the photo plate. In addition, some shards with impressed decorations, and peculiar vessels –oil lamps and a lug of cooking pot (?) are also presented together.





TP26-C1



TP26-S1



TP26-S2



TP26-S3



TP26-S4



Smoking pipes from TP26 (1)



TP26-S5



Smoking pipes from TP26 (2)



TP26-I1



TP26-I2



Smoking pipes from TP26 (3)







Earthenware pieces from TP26 (1)



Earthenware pieces from TP26 (2)

10cm

# Test Pit 27

Location: Near Vat Sisaket

Excavation Date: August 16th, 2004

Identified Working Infrastructure(s): Water pipes: 2

Identified Archaeological Feature(s): Brick structure: 1

Recovered Artifacts: 691

Stoneware: 156, Earthenware: 79, Imported ceramics: 17,

Stone tools: 4, Stone: 6, Brick: 59, Metal Object: 7, Stucco/Mortar: 2,

Wooden Object: 1, Roof Tile: 357, Architectural Ornaments: 3

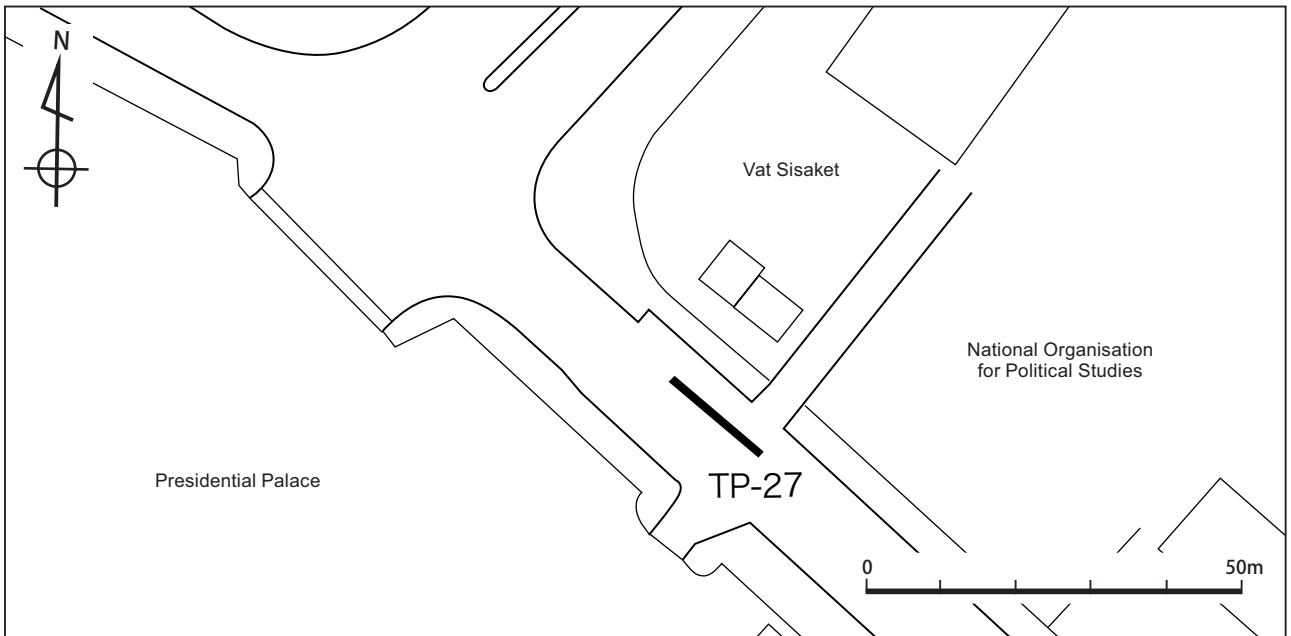
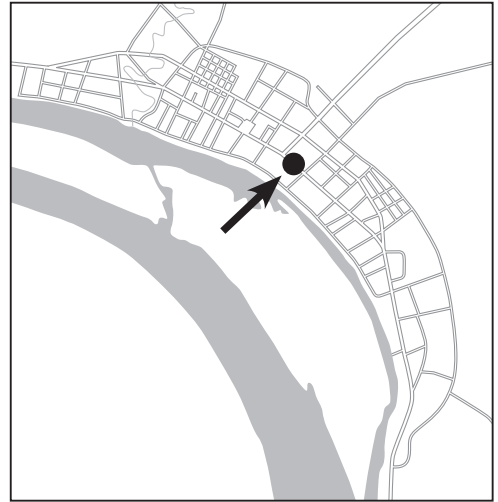

**Point E27-36**

Coordinates:  
 X=87,711.269  
 Y=46,982.054  
 EL=170.29m

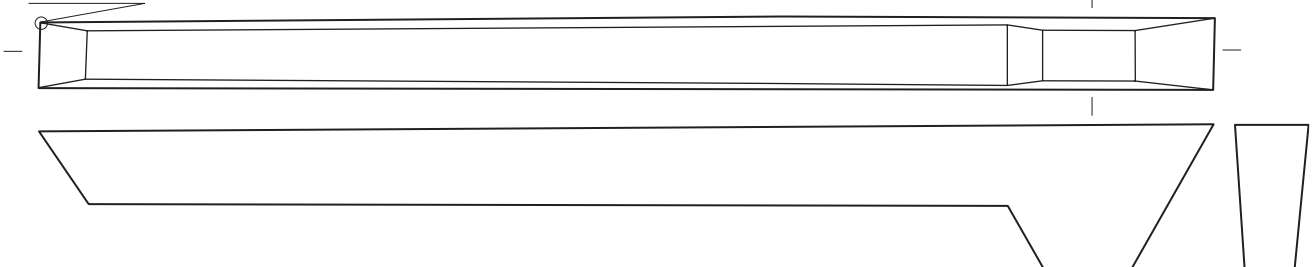

Test Pit Dimention (max.)	
Length:	15.60m
Width:	0.95m
Depth:	1.88m
Surface Area:	14.82m <sup>2</sup>

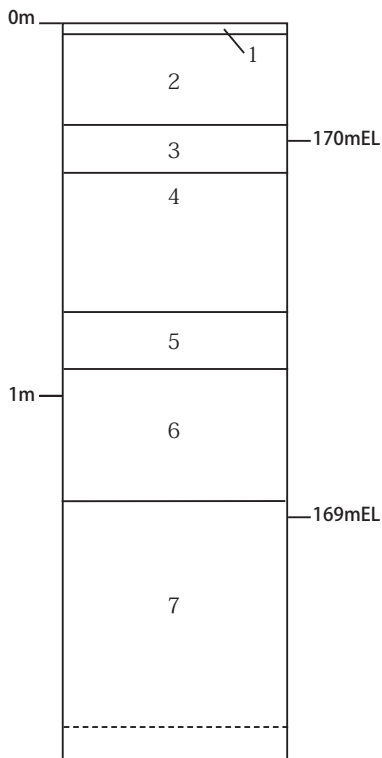

**Explanation of Soil Layers**

- 1 Asphalt: Present road surface.
- 2 Pebble/Laterite soil: Sub-base layer for the present road surface.
- 3 Compacted bricks: Earlier pavement?
- 4 Dark grey-brown silt layer. Probably sub-base layer for the earlier road surface.
- 5 Dark grey silty clay. Artifacts found from this layer.
- 6 Grey silty clay: Uniform and with no inclusion.
- 7 Grey clay: Uniform and with no inclusion.



View of the excavation site



Test Pit 27 after excavation



Wooden artifact (TO27-W1) *in situ*



A brick structure (TP27-ST1)



## Structures

A brick structure was detected at north side of this trench (about 60 cm in depth, TP27-ST1). This structure was disturbed by the north wall of trench, and the rest part seemed to continue to outside of trench area. A few fragments of stucco/mortar scattered around this structure.

The function of this structure is unidentified, but it is probably a part of brick wall extending north-south direction. The south part of this structure seemed to be destroyed when the water pipe was laid in the second half of 20th century. The sizes of bricks are on the list below.

This brick structure was not dismantled and the trench was refilled by sand.

## Artifacts

### Roof tiles

357 shards of flat roof tiles were unearthed. Only 1 shard of them is a fragment of thick tile (14 mm). Each 2 of 348 shards keeps its full width (see the list below, TP27-R1, -R2).

The trace of texture is observed on the one surface of the each of 2 shards. The thickness of these whitish shards are 7 ~ 8 mm.

### Bricks

8 pieces of bricks, each of which keeps its original length, width, and thickness, and 51 broken blocks were picked up. Each of 38 blocks of them keeps its width and thickness only (see the list below). 1 broken part of semicylindrical (?) block was included.

### Metal objects

6 small pieces of melted slugs and 1 part of the furniture fitting (?) were unearthed.

### Wooden objects

1 part of hollow log (approximately 45 cm in length and 22 cm in diameter) was unearthed (TP27-W1). There was not foundation stone but fragments of bricks under this log, therefore its use is unclear.

### Stucco/Mortar

2 blocks of stucco/mortar were unearthed. 1 block of them has molding (TP27-C1).

### Architectural ornaments

3 pieces of stoneware fragments, which are probably a kind of the decorations of the ridge (crest) or decorations of

Length	Width	Thickness	Remarks
240	120	60	
255		45	width is unknown
260	135	75	
270	150	65	

Measurements of bricks from structure TP27-ST1 (mm)

Width	Thickness	Remarks
150	8	A part of rear end with stopper
151	8	A part of rear end with stopper

Measurements of rooftiles from TP27 (mm)

Length	Width	Thickness	Length	Width	Thickness	Length	Width	Thickness	Length	Width	Thickness	
195	96	40		108	39		118	34			131	45
	100	45		110	47		118	55		228	131	46
	100	45		111	40		119	39			132	46
	101	44		111	46		120	38			132	53
	102	50		113	34		121	38			132	62
	102	58		113	50		121	52			134	64
218	104	43		114	43	225	122	57			136	50
	105	33	246	114	77		123	55			137	52
	105	33		115	56		124	49		235	137	66
	107	37		116	58		126	40			147	66
202	107	40		117	43		126	46				
218	108	35		117	48		126	62				

Measurements of bricks from TP27 (mm)



the gableboard of temple architecture like sim, were unearthed (TP27-A1 to A3).

Refer to the description in TP12.

#### Stoneware

There are 156 pieces of stoneware shards recovered from the excavation at Test Pit 27. Their contents of shape classes seem to be almost common to the findings from other test pits. There is no significant or peculiar specimen to be reported. The findings including a few glazed stoneware, are classified and counted in each shape class as follows;

Mortar or bowl type wares: 38 pieces (14 shards of rim part, 23 shards of body and one shard of base part)

Jar or bottle type wares: 110 pieces (two shards of shoulder part of possible "water-trap jar", 15 shards of base part, 87 shards of body part and six shards of rim part)

Oil lamp: three pieces (two shards of the center post part and one shard of the saucer) Ash-glazed bowl: five pieces (two shards of rim part, one shard of body part and two shards of base part with vertical grooved decoration)

#### Imported ceramics

There are only 17 pieces of imported ceramics unearthed from the Test Pit 27. There is no peculiar specimen to be reported. The findings are classified and counted as follows;

Chinese underglazed blue and white wares in Ming to early Qing dynasties: two pieces of bowl (body parts) and one piece of basin (base part, probably manufactured in Jindezhen kilns during "Wanli" period of Ming dynasty)

Chinese underglazed blue and white wares in later Qing dynasty: six pieces of bowl (one shard of rim part and five shards of body part)

Chinese white porcelain: one piece of bowl (body part), which is so-called "Qing-pai" ware manufactured in Jindezhen kilns during Southern Sung or early Yuan dynasties.

Chinese over glaze red-enamel painted wares in modern period: one piece of bowl (body part)

Thai's brown glazed stoneware: four pieces of large jar (body parts)

Vietnamese over-glaze enamel painted ware: two pieces of bowl (rim parts)

#### Earthenware

There are 79 shards of earthenware recovered at the Test Pit 27. The shards of rim parts count only six pieces. Their shape classes are the straight-standing type with small protruded edge, which may be common to the findings from TP.11. There are also some shards with impressed decorations were recovered as introduced in the photo plate. Especially, one of them exists a peculiar motif of a series of small double circles. This specimen is a rim part of possible mortar or basin type ware and the decor is impressed on the interior, while most other shards with the decorations are body to neck parts of jar typed wares (of course, the decors are remained on their exteriors).



TP27-A1 to A3



TP27-C1

10cm



Earthenware pieces from TP27



10cm

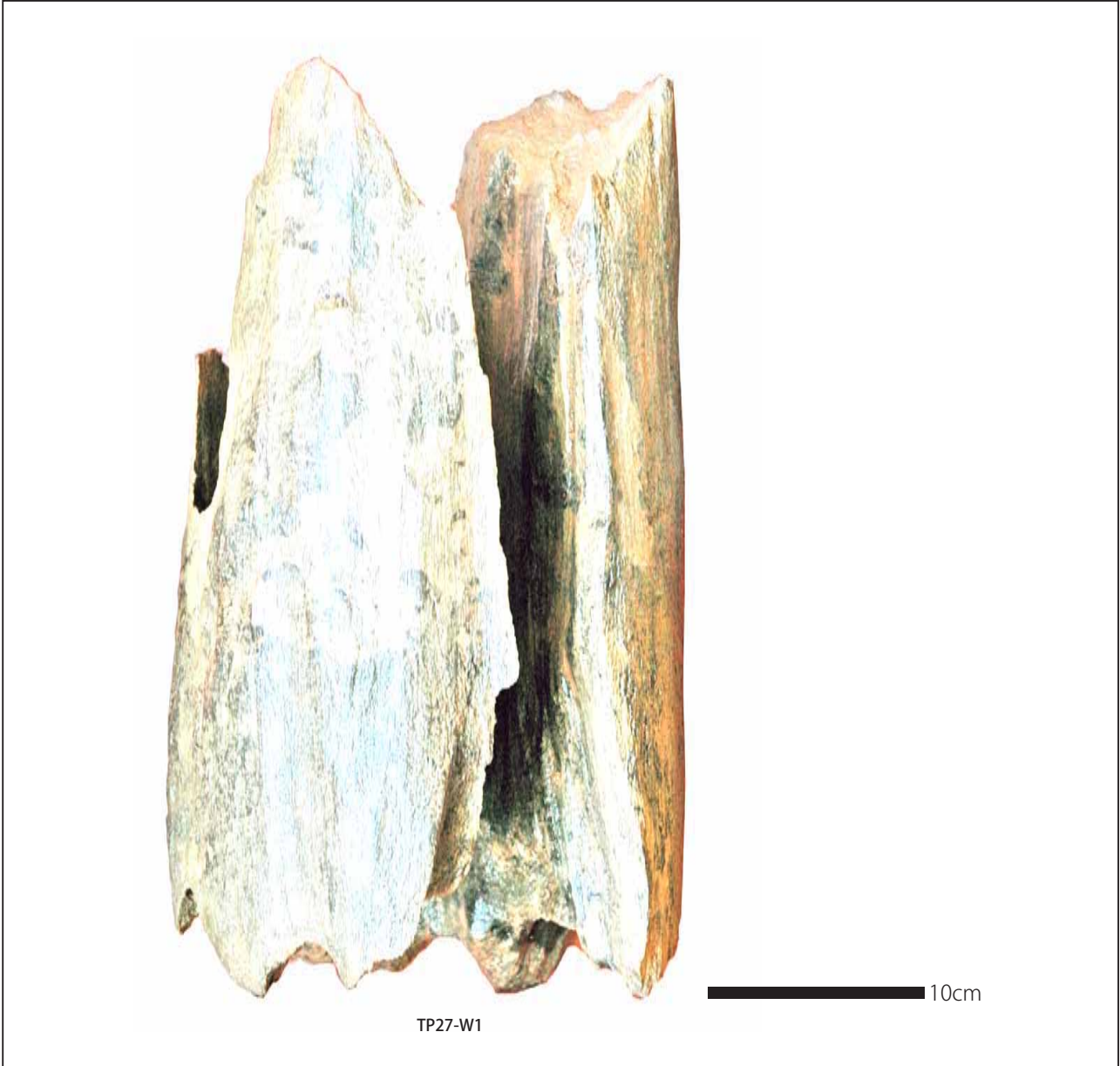

TP27-W1

10cm

# Test Pit 28

Location: Near Vat Ho Pakeo.

Excavation Date: August 17th, 2004

Identified Working Infrastructure(s): None

Identified Archaeological Feature(s): None

Recovered Artifacts: 990

Stoneware: 373, Earthenware: 267, Imported ceramics: 105,  
 Bone: 28, Stone tools: 4, Stone: 17, Brick: 33, Metal Object: 12,  
 Stucco/Mortar: 9, Roof Tile: 142

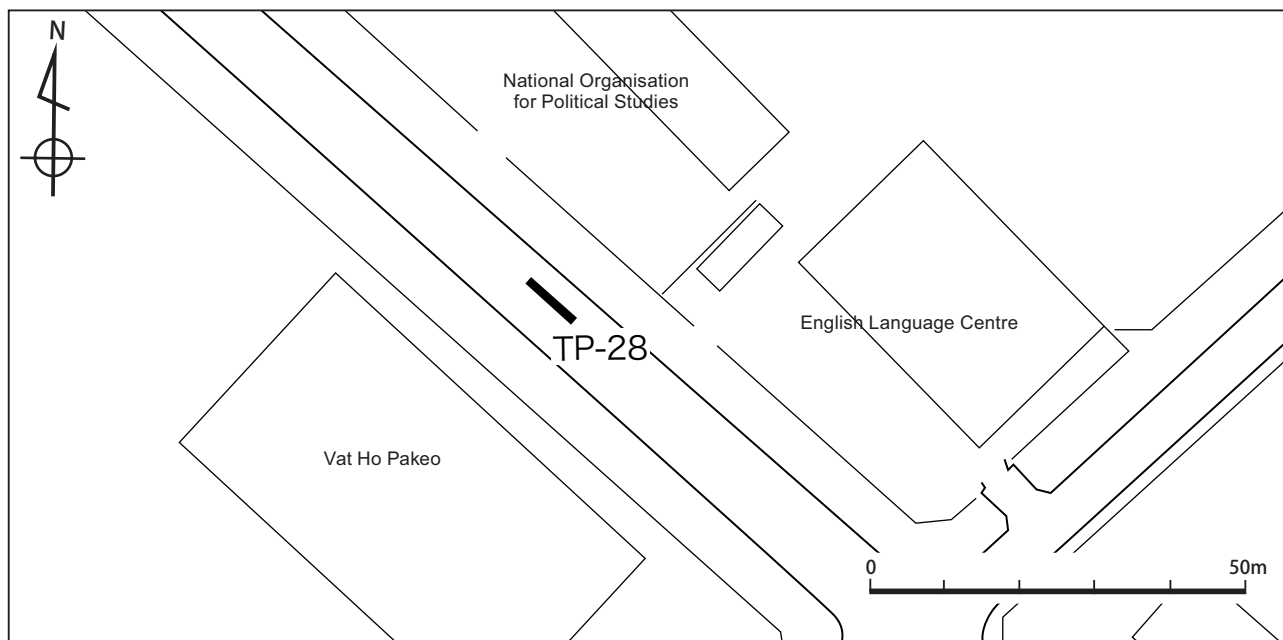
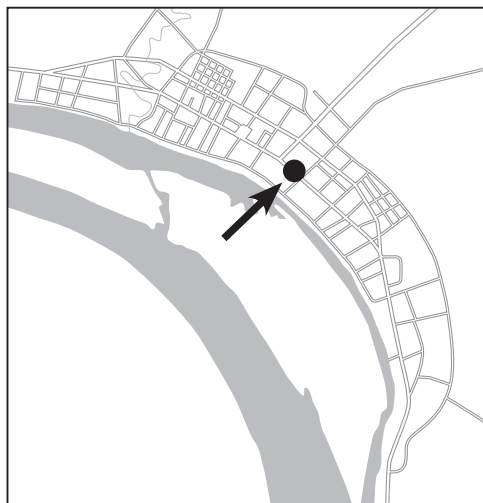

**Point E28-13**  
 Coordinates:  
 X=87,635.368  
 Y=47,070.463  
 EL=170.36m

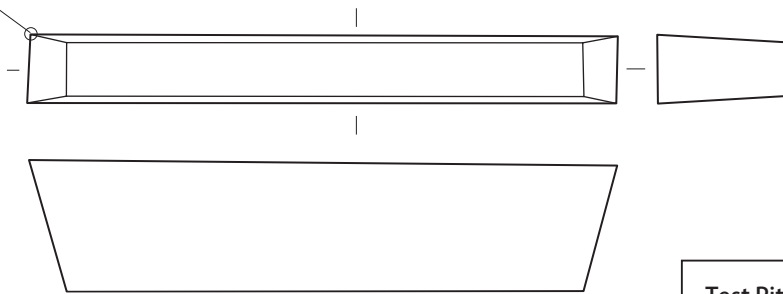

Test Pit Dimention (max.)
Length: 7.79m
Width: 0.94m
Depth: 1.73m
Surface Area: 7.32m <sup>2</sup>



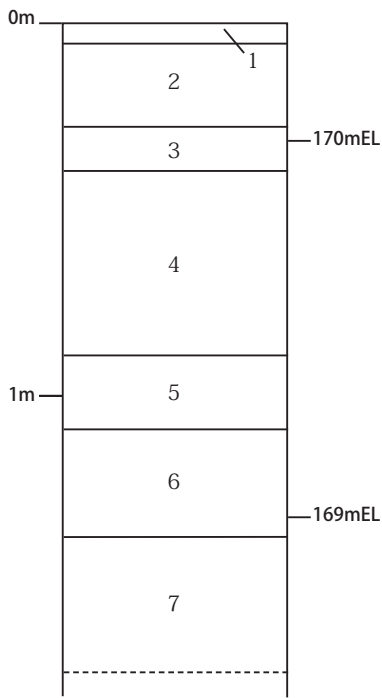

### Explanation of Soil Layers

- 1 Asphalt: Present road surface.
- 2 Pebble/Laterite soil: Sub-base layer for the present road surface.
- 3 Compacted bricks: Earlier pavement?
- 4 Dark grey-brown silt layer. Probably sub-base layer for the earlier road surface.
- 5 Dark grey silty clay. Artifacts found from this layer.
- 6 Grey silty clay: Uniform and with no inclusion.
- 7 Grey clay: Uniform and with no inclusion.



Site of the excavation



Excavation in progress



Unearthed earthenware



View of the Test Pit 28 after excavation



## Artifacts

### Bricks

Three pieces of bricks, each of which keeps its original length, width, and thickness, and 30 broken blocks were picked up. Each of 10 blocks of them keeps its width and thickness only (see the list below). One broken part of fan-shaped (?) block was included.

### Metal objects

One complete rusted cut nail approximately 95 mm long and a part of rusted nail, two blades of farming implements or tools, a small piece of melted slug, and seven small fragments were unearthed.

Length	Width	Thickness	Remarks
174	85	45	
	88	41	
	89	42	
	98	36	
	104	42	
	110	45	
	111	48	
230	112	52	
240	113	42	
	113	48	
	115	50	
	123	45-55	thickness is irregular
	127	45	

Measurements of bricks from TP28 (mm)

### Stucco/Mortar

Nine small blocks of stucco/mortar were unearthed. 1 block of them may be a part of ornament.

### Stoneware

There are profuse amount of ceramics recovered from the Test Pit 28. The stoneware shards count 373 pieces in total. The findings demonstrate wide variations, however, their contents of shape classes are almost common to the findings from other test pits. There is no significant or peculiar specimen to be reported with photos. The findings are classified and counted in each shape class as follows; mortar or bowl type wares: 46 pieces (15 shards of rim part, 22 shards of body and nine shards of base part), stem bowl: one piece (bowl part), bowl with an incised or grating surface on the interior: three pieces (two shards of rim part, one shard of body part), jar or bottle type wares: 305 pieces (26 shards of base part, 254 shards of body part, 25 shards of rim part and one shard of rim to shoulder part with lug), oil lamp: seven pieces (two shards of the center post part and five shards of the saucer part), smoking pipe: seven pieces (six shards of stem part and one shard of bowl part), lug for jar typed ware: three pieces, ash-glazed bowl: four pieces (one shard of rim part, two shards of body part and one shard of base part).

### Imported ceramics

There are quite large number of imported ceramics unearthed from the Test Pit 28, which count 105 pieces in total. The specimens demonstrate wide variations in their origins and production periods, which are classified and counted as follows; Chinese underglazed blue and white wares in Qing dynasty probably including a few modern products: 35 pieces of bowl (25 shards of rim part, six shards of body part and four shards of base part), one piece of dish (rim part), four pieces of plate (two shards of rim part and two shards of base part) and one piece of round box (cover part), Chinese white porcelain: two pieces of bowl (one shard of rim part and one shard of body part) and one piece of plate (base part), Chinese over glaze red-enamel painted wares in later Qing dynasty to modern period: two pieces of bowl (one shard of rim part and one shard of body part), one piece of small plate or dish (rim to body part), Chinese monochrome wares: one piece of small bottle (body part with lapis-lazuli blue glaze), Chinese brown glazed stoneware probably Yuan to early Ming dynasties: two pieces of bowl (one shard of rim and one shard of body part), Thai's celadon glazed stoneware around 15th century: three pieces of bowl (one shard of rim and two shards of body part), seven pieces of basin or plate (one shard of rim part, four shards of body part and two shards of base part), Thai's under-glaze iron painted ware: one piece of lid for vessel (body part), Thai's brown glazed stoneware: one piece of bowl (rim part) and 25 pieces of large jar (fragments of body parts), Vietnamese underglazed blue and white ware: six pieces of bowl (one shard of rim part, two shards of body part and three shards of base part), Vietnamese over-glaze enamel painted ware: one piece of bowl (body part) and one piece of dish (rim to body part), Japanese underglazed blue and white porcelain dated probably in the latter half of 19th century: four pieces of bowl (one shard of rim, two shards of body and one shard of base part), Brown (iron) and ash glazed stoneware (Khmer ceramics?): one piece of bowl or jar? (body part), unidentified stoneware with glaze: one piece of bowl (body part); its glaze is milky white in colour, thick layered and completely opaque. The paste is very coarse and crumbly with many pores.

TP28-I1 are rim and body to base parts of an underglazed blue and white bowl with a tall foot-ring. Its estimated sizes measure 15.6cm in diameter at the top end of mouth-rim and 6.8cm in diameter at the bottom end of foot-ring. Its paste is nearly white in colour, solid but slightly coarse including a lot of very small black particles. There are underglaze decorations painting multi-petal flowers and other motifs in dark (indigo) blue colour existed on the interior bottom, mouth-rim and all over the exterior wall. The glaze is pale white in colour, transparent and shiny. It is partially wiped off only around the bottom end of the foot-ring. The specimen was probably manufactured in Southern China or Vietnam between 18th and 19th centuries. But it is difficult to clarify its origin and date. There are considerable numbers of similar typed wares to the specimen recovered from several test pits.

TP28-I2 is a small shard of glazed stoneware, which original form is assumed to be a bowl or a large jar with wide mouth. Its paste is light grey in colour, rather fine and solid. The glaze on the exterior presents dark brown probably including iron, while its interior glaze is pale greyish white in colour, which seems a kind of ash glaze. It should be quite peculiar to use two different types of glaze for one object. The origin of the specimen is unidentified, as its glaze and paste differ clearly from Thai or Vietnamese products. It is estimated to be made in China, according to the characteristic of its glaze, however, there is also a possibility that this is a Khmer ceramic which was manufactured in the present western Cambodia around Siem Reap (the former capital Angkor) or in the Thai's eastern provinces near the border to Cambodia, during the Khmer empire or Angkorian period between 10th and 13th centuries.

#### Eartehware

There are comparatively large amount of earthenware recovered at the Test Pit No.28, which count 267 pieces in total. The shards of rim parts count 35 pieces. Their shape-classes present similar characteristics to the finds from other test pits such as TP18. Besides, there are six shards of base parts recovered, three pieces of which are shown in the photo plate. One piece is a flat base of probable large jar typed ware. The other one piece has a trimmed base with high foot-ring, which complete form is unclear. The last one piece is considered to be a base of oil lamp, as the trace of a large post is remained on the interior bottom.

On the other hand, there are recovered 24 pieces of shards with impressed decorations, which demonstrate quite wider variations than other test pits' findings. Some characteristic specimens, most of which have decors of cross-stripes, oblique lines or herringbone like motifs, while including one rim part with decor of small circles motif, are presented in the photo plate.

The newer earthenware groups with fine-grained paste are also unearthed. The photo plate shows one piece of oil lamp shaped object (which size measures 7.3cm in diameter at the top end of rim part) and one piece of spout part of pitcher or "Kendi" ware (which surface are painted in red).

Except for these above-mentioned fragmentary shards, there was recovered one piece of large basin shaped earthenware, which detected *in situ* is shown on the photo plate of the field excavation report. The specimen remains nearly half part of its complete form. Its estimated sizes measure approximately 32cm in outer diameter at the top end of mouth-rim, 23cm in outer diameter at the bottom end and 14.3cm in its height. The paste varies in colour from ivory, through a range grey to black, and light greyish orange. Its texture is rather coarse with high porosity including a lot of white particles (possibly feldspar), while mica particles can not be recognized by the naked eye. The exterior base is not trimmed, but its center part is dented to the upper. That is, only around the edge (rim) of base is attached directly to the ground.

Most part of the surface on the upper part of interior wall and the interior base are carbonized and exist black in colour because of soot or fired (burnt) effect, while, strange to say, there is no blackened part on whole the exterior at the remained part. It should be curious that only interior part of the vessel exists burnt evidence. As generally considering, or in the case of a cooking pot being set up over a fireplace for instance, only its lower exterior (base to lower body part) should be exposed to flame of firing and blackened (carbonized). Therefore, it can be supposed that the specimen had been used as not a kind of pot, but a something like a portable stove to make a fire inside of the vessel or a container of embers.



TP28-11

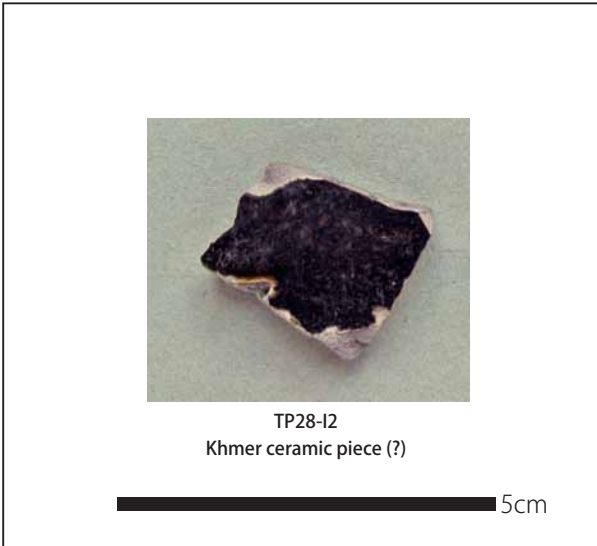

Earthenware pieces from TP28 (1)



Earthenware pieces from TP28 (2)







Earthenware pieces from TP28 (3)



Earthenware bowl from TP28





# Test Pit 29

Location: Near Vat Kaognot.

Excavation Date: August 18th, 2004

Identified Working Infrastructure(s): None

Identified Archaeological Feature(s): None

Recovered Artifacts: 1030

Stoneware: 167, Earthenware: 87, Imported ceramics: 49, Bone: 5,

Stone tools: 5, Stone: 14, Brick: 20, Metal Object: 23,

Stucco/Mortar: 3, Roof Tile: 645

Note:

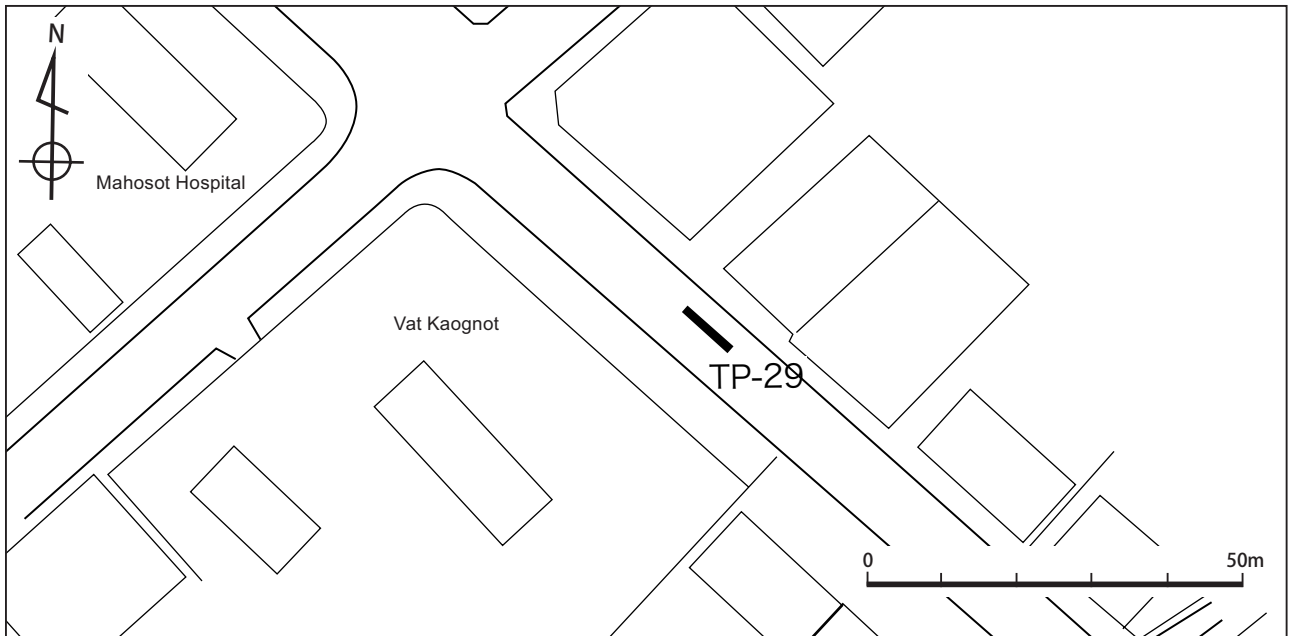
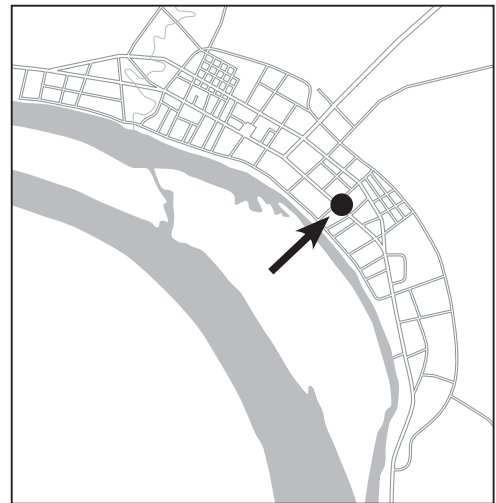

**Point E29-25**

Coordinates:

X=87,345.643

Y=47,390.720

EL=170.00m

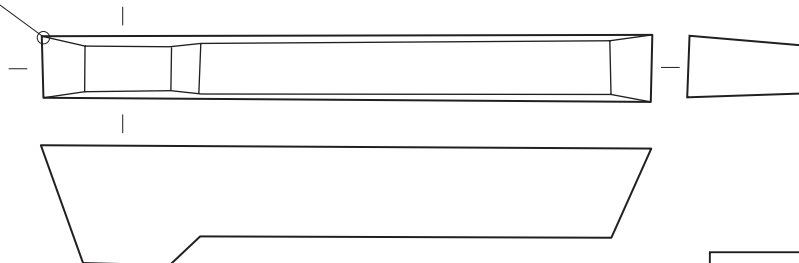

**Test Pit Dimention (max.)**

Length: 8.08m

Width: 0.85m

Depth: 1.58m

Surface Area: 6.87m<sup>2</sup>

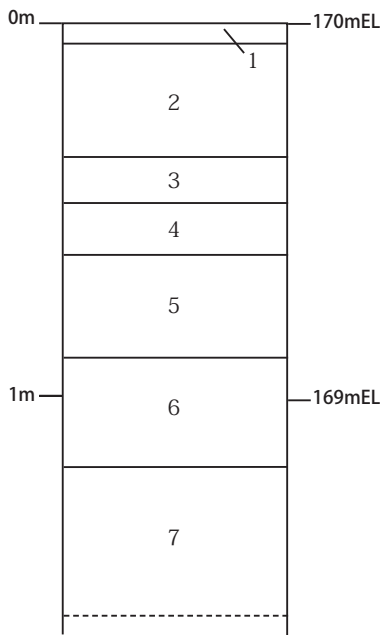

**Explanation of Soil Layers**

- 1 Asphalt: Present road surface.
- 2 Pebble/Laterite soil: Sub-base layer for the present road surface.
- 3 Compacted bricks: Earlier pavement?
- 4 Dark grey-brown silt layer. Probably sub-base layer for the earlier road surface.
- 5 Dark grey silty clay. Artifacts found from this layer.
- 6 Grey silty clay: Uniform and with no inclusion.
- 7 Grey clay: Uniform and with no inclusion.



Unearthed stoneware



Unearthed metal utensil



Excavation in progress



Excavation in progress

## Artifacts

### Roof tiles

645 various colored shards of thin flat roof tiles were unearthed. They are stoneware roof tiles and earthen ware ones.

### Bricks

20 broken blocks were picked up. Each of 12 blocks of them keeps its width and thickness (see table at the right).

Width	Thickness
87	43
90	40
91	36
91	51
95	60
97	49
102	56
105	50
107	34
108	44

Measurements of bricks from TP29 (mm)

### Stoneware

There are comparatively large amount of ceramics recovered from the excavation at Test Pit 29. The stoneware shards count 167 pieces in total. The findings demonstrate wide variations including ash-glazed wares and also some peculiar objects, while most of shape classes in the categories of jar and bowl typed wares are seemingly common to the findings from other test pits. The findings are classified and counted in each shape class as follows; Mortar or bowl type wares: 26 pieces (14 shards of rim part, 10 shards of body and two shards of base part), bowl with an incised or grating surface on the interior: two pieces (rim parts), jar or bottle type wares: 126 pieces (nine shards of base part, 103 shards of body part, 13 shards of rim part and one piece of nearly complete form), oil lamp: six pieces (all are saucer parts), lug for jar typed ware: one pieces, unidentified objects: one piece of shallow dish shaped ware with untrimmed flat base and one piece of disk perforated at the center, which thickness measures around 2.1cm, ash-glazed bowl: three pieces (one shard of rim part with shaved decorations of vertical grooves, one shard of body part with vertical grooves and one shard of body part with no grooves decor), ash-glazed jar: one piece of base part, and ash-glazed smoking pipe: one piece of the bowl part

TP29-S1 is a jar with two lugs, which was unearthed in nearly complete form. It has lost only the top end of mouth-rim and lug parts. Its sizes measure 8.8cm in diameter at the bottom end 15.9cm in height at the remained part. The paste is dark grey in colour, considerably fine and solid, which texture seems rather high quality compared to the average texture of local-made stoneware. There is an incised decoration of three circumferential lines running horizontally around its shoulder part.

TP29-S2 is a rim part of large jar. Its estimated size measures around 46cm in diameter at the top end of mouth-rim. It should be extremely large sized vessel. The paste is light grey in colour, slightly coarse grained but solid. There is no decoration on the remained part, while natural glaze effect from fly-ash exists partially on the exterior mouth-rim.

TP29-I3 is a bowl part of ash-glazed smoking pipe. The glazed type of smoking pipe should be quite rare compared to the normal pipes with no glaze which are unearthed in large amount from several test pits. Its size measures 2.2cm in diameter at the inner edge of mouth-rim. The paste is light grey in colour, relatively fine-grained and solid. There are impressed and incised decorations of circumferential lines and lotus petals like motifs on the exterior of bowl part. The glaze is light greyish green in colour, nearly transparent and very shiny.

### Imported ceramics

There are 49 pieces of imported ceramics unearthed from the Test Pit 29. There is no peculiar specimen to be reported.

The findings are classified and counted as follows; Chinese underglazed blue and white wares in Qing dynasty and modern period: 18 pieces of bowl (eight shards of rim part, 13 shards of body and three shards of base parts) and one piece of plate (rim part), Chinese over-glaze enamel painted wares in modern period: three pieces of bowl (one shard of rim and two shards of body parts), Thai's celadon glazed stoneware: three pieces of basin (two shards of rim and one shard of body part), Thai's under-glaze iron painted stoneware: two pieces of bowl (rim parts), Thai's brown glazed stoneware: one piece of mortar shaped vessel (rim to body part) and seven pieces of jar typed ware (two shards of rim and five shards of body parts), Vietnamese under-glaze blue and white ware: six pieces of bowl (one shard of rim and five shards of body parts)

## Earthenware

There are 87 shards of earthenware recovered at the Test Pit 29. The shards of rim parts count ten pieces. There is no peculiar specimen. Most of their shape classes are the straight-standing type with small protruded edge, which is common to the findings from TP11. One piece of base part is a miniature size of oil lamp, which measures 5.1cm in diameter at the top end of mouth-rim. There are also five shards with impressed decorations were recovered. One of them has quite peculiar and interesting decorations of a series of fine dots, alphabet letters "S" and "V" like motifs, as introduced in the photo plate. The specimen has quite fine-grained paste in greyish ivory in colour, that is clearly different from other shards with decorations, which pastes are basically coarse-grained with many pores, including red, black and white particles.

As same as other Test Pit s, the newer earthenware groups with fine-grained paste are also unearthed. The photo plate shows one base part of large jar which has impressed decorations of peculiar motif (fine dotted circumferential lines and cross-shaped small flower?) on the lower exterior and one piece of spout part of pitcher or "Kendi" ware. Both have light orange coloured, very fine-grained paste with red-painted surface, which belong to the Type-A mentioned above at the section of TP23.

## Stone tools

Two pieces of cylindrical grinding stones made of sandstones were found (TP29-T1 and T2). T1 measures 198 x 56 x 48mm and weighs 612 grams and T2 measures 140 x 35 x 33mm and weighs 267 gram. Another piece (T29-T3) is peculiar one with groove which resembles shaft-polisher. It is made also of sandstone and measure 121 x 64 x 26 mm and weigh 300 grams.



TP27-S01



TP27-S02

10cm





TP29-S3

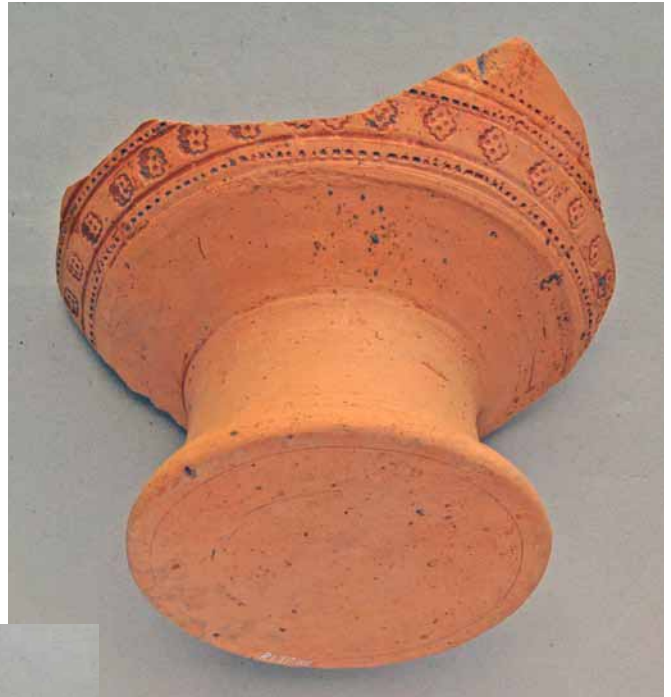

Earthenware pieces from TP29



TP29-M1

10cm



TP29-T1



TP29-T2



TP29-T3

# Test Pit 30

Location: Near Vat Simuang

Excavation Date: August 19, 2004

Identified Working Infrastructure(s): None

Identified Archaeological Feature(s): None

Recovered Artifacts: 339

Stoneware: 138, Earthenware: 74, Imported ceramics: 84, Bone: 14,

Stone: 9, Brick: 5, Metal Object: 1, Roof Tile: 14

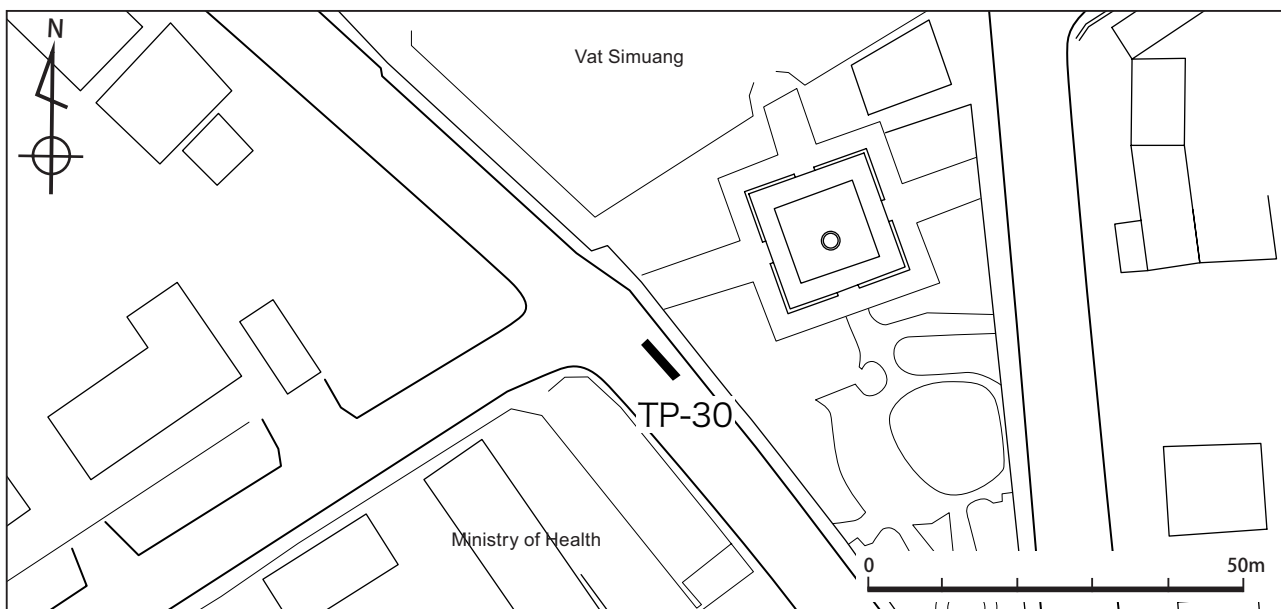
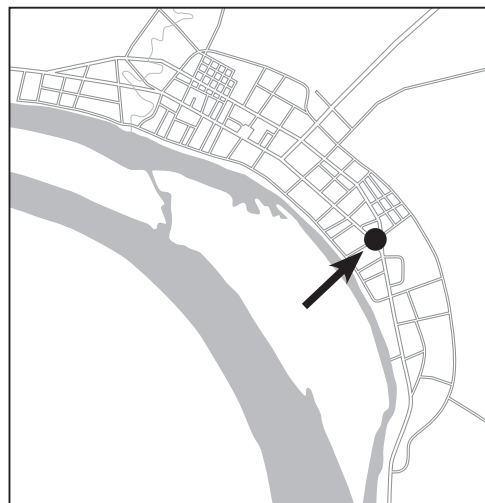

**Point E30-40**  
Coordinates:  
X=87,113.831  
Y=47,650.872  
EL=170.01m

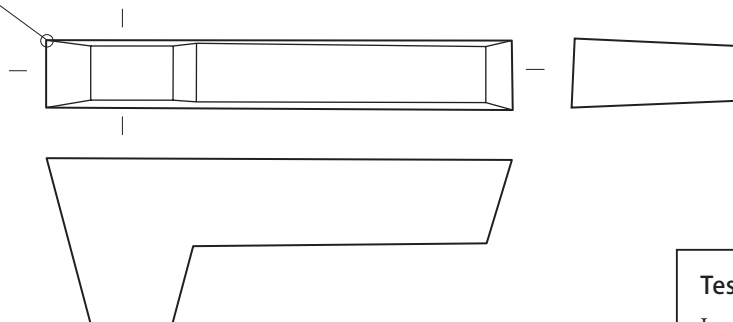

### Test Pit Dimention (max.)

Length: 6.22m

Width: 0.90m

Depth: 2.19m

Surface Area: 5.60m<sup>2</sup>



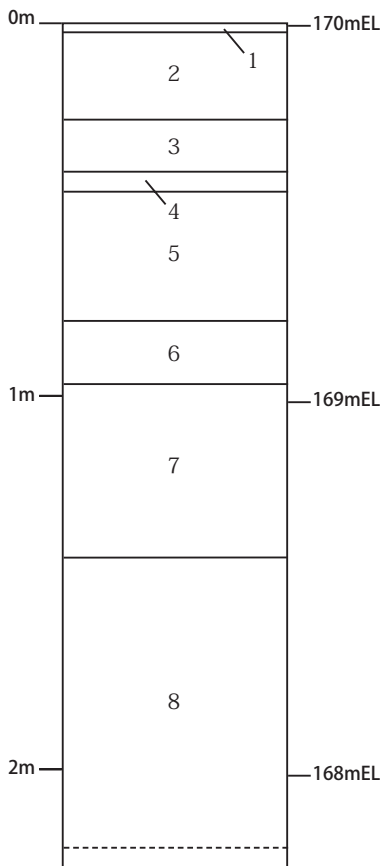

**Explanation of Soil Layers**

- 1 Asphalt: Present road surface.
- 2 Pebble/Laterite soil: Sub-base layer for the present road surface.
- 3 Brown-grey silt with bricks: Earlier pavement?
- 4 Dark grey silt layer. Probably sub-base layer for the earlier road surface.
- 5 Dark grey-brown silt layer. Probably sub-base layer for the earlier road surface.
- 6 Dark grey silty clay. Artifacts found from this layer.
- 7 Grey-brown silty clay: Uniform and with no inclusion.
- 8 Grey clay: Uniform and with no inclusion.



**Artifacts**

**Roof tiles**

14 shards of thin flat roof tiles were unearthed.

**Bricks**

Five broken blocks of bricks were picked up. One block of them keeps its width and thickness (see the list below).

**Metal objects**

A part of rusted nail was unearthed.

Width	Thickness
113	45

Measurements of bricks from TP30 (mm)

**Stoneware**

There are comparatively large amount of ceramics recovered from the excavation at Test Pit 30. The stoneware



View of the Test Pit after excavation



Colonial-era brick foundation



shards count 139 pieces in total. There are not so wide variations in the shape classes of findings as other test pits, namely most of jar and bowl typed wares and some other objects are seemingly common to the findings from other test pits. The findings are classified and counted in each shape class as follows; Mortar or bowl type wares: 31 pieces (12shards of rim part, 18 shards of body and one shard of base part), bowl with an incised or grating surface on the interior: two pieces (one shard of body part and one shard of base part), jar or bottle type wares: 98 pieces (eight shards of base part, 82 shards of body part and eight shards of rim part), jar with a flange around mouth-rim or the "water trap jar": one piece of rim to body part, oil lamp: one piece (saucer part), smoking pipe: two pieces (stem parts), ash-glazed bowl: four pieces (all rim parts with no groove decoration remained).

TP30-S1 is a rim to body part of a peculiar jar classified as so-called "water trap jar", which has a flange around the mouth to form a circular channel, presumably to hold water as an insect barrier, especially when a lid is fitted. The same shaped vessels are still used commonly in provinces of Laos. Exactly speaking, the specimen has lost its upper parts of mouth and flange, however it can be identified the original form by observing its profiles on the broken faces. Additionally, it should be interesting and notable that its flange part were formed first together with body part on the potter's wheel, then the mouth-rim part (formed on the wheel separately) was attached after along the interior wall of the flange part. These actual manufacturing method may be against ordinary prejudices that the flange part should be something like optional accessory applied later.

The paste of specimen is purple or brownish dark grey in colour, considerably fine and solid. It seems to be well-fired and there are natural effect of fly-ash in greyish white colour spread all over the exterior around the flange to shoulder part.

#### Imported ceramics

There are quite large number of imported ceramics unearthed from the Test Pit 30, which count 84 pieces in total. The specimens demonstrate wide variations in their origins and production periods as same as the contents of finds from other test pits such as TP28. The findings are classified and counted as follows; Chinese underglazed blue and white wares during mainly Qing dynasty (possibly including a few modern products): 20 pieces of bowl (eight shards of rim part, ten shards of body part and two shards of base part), two pieces of dish (one shard of rim and one shard of base part), three pieces of basin or plate (one rim part, one body part and one shard of base part) and one piece of small bottle (base part). Chinese white porcelain: three pieces of bowl (one shard of base part and two shards of body part), one of which is a so-called "Qing-pai" or bluish white ware, Chinese over glaze red-enamel painted wares in later Qing dynasty to modern period: seven pieces of bowl (one shard of rim part, five shards of body and one shard of base part) and ten pieces of plate or dish (six shards of rim, two shards of body and two shards of base parts)

Thai's celadon glazed stoneware around 15th century: four pieces of bowl (one shard of rim and three shards of body part), two pieces of basin or plate (one shard of body part and one shard of base part) and four pieces of jar typed ware (body parts), Thai's under-glaze iron painted ware: five pieces of bowl (two shards of rim and three shards of body part)

Vietnamese underglazed blue and white ware: five pieces of bowl (four shards of body part and one shard of base part) and one piece of small jar (body part), Vietnamese over-glaze enamel painted ware: seven pieces of bowl (three shards of rim and four shards of body part), three pieces of plate (body parts) and one piece of round box (cover part)

Japanese underglazed blue and white porcelain dated probably after the middle of 19th century: five pieces of bowl (two shards of rim, two shards of body and one shard of base part), Brown (iron) and ash glazed stoneware (Khmer ceramics?): one piece of jar (body part)

TP30-I1 is a small shard of glazed stoneware, which may be a neck part of a large baluster formed jar with wide flared mouth. Its paste is light grey in colour, slightly coarse but solid. The glaze on the exterior are brownish black in colour and opaque probably including iron, while its interior glaze is light greyish green in colour, translucent and shiny, which seems a kind of ash glaze. It should be quite peculiar to use two different types of glaze for one object. The specimen has quite similar texture of paste and glaze to one shard (TP28-I2) recovered at the Test Pit 28. As reported above, according to the characteristic of its glazes, there is a possibility that the specimen is also a Khmer ceramic which was manufactured in some kilns inside of ancient Khmer territory during the Angkor period or between 10th and 13th centuries.

## Earthenware

There are 74 shards of earthenware recovered at the Test Pit 30. The shards of rim parts count seven pieces. Its each shape classes may be in the category of the straight-standing type with small protruded edge, which is common to the findings from TP11. There are also eleven shards with impressed decorations were recovered. Most of them have common decorations of oblique lines, cross-stripes or herring-bone like motifs, as introduced in the photo plate.

The newer earthenware groups with fine-grained paste are also unearthed. The photo plate shows one base part of large jar and three shards of shoulder parts of jar (or "Kendi" ?)typed wares. One shoulder part fragment of them has impressed decorations of peculiar motifs (fine dotted circumferential lines and cross-shaped small flower?), which motifs are almost same as the specimen unearthed at TP29, as mentioned above. All these with fine-grained paste exist red-painted surface, which belong to the Type-A mentioned above at the section of TP23.



TP30-S1



TP30-I1  
Khmer ceramic piece (?)

5cm



Earthenware pieces from TP30

10cm

# Test Pit 31

Location: Near Vat Impeng.

Within the range of old Vat Impeng perimetre.

Excavation Date: August 20, 2004

Identified Working Infrastructure(s): None

Identified Archaeological Feature(s): None

Recovered Artifacts: 200

Stoneware: 14, Earthenware: 4, Imported ceramics: 4, Bone: 1,

Stone: 2, Brick: 16, Metal Object: 3, Stucco/Mortar: 18,

Roof Tile: 133

Note: An auxillary Test Pit opened to search for the remain of a stupa of Vat Impeng described in Parmentier's "L'Art du Laos."

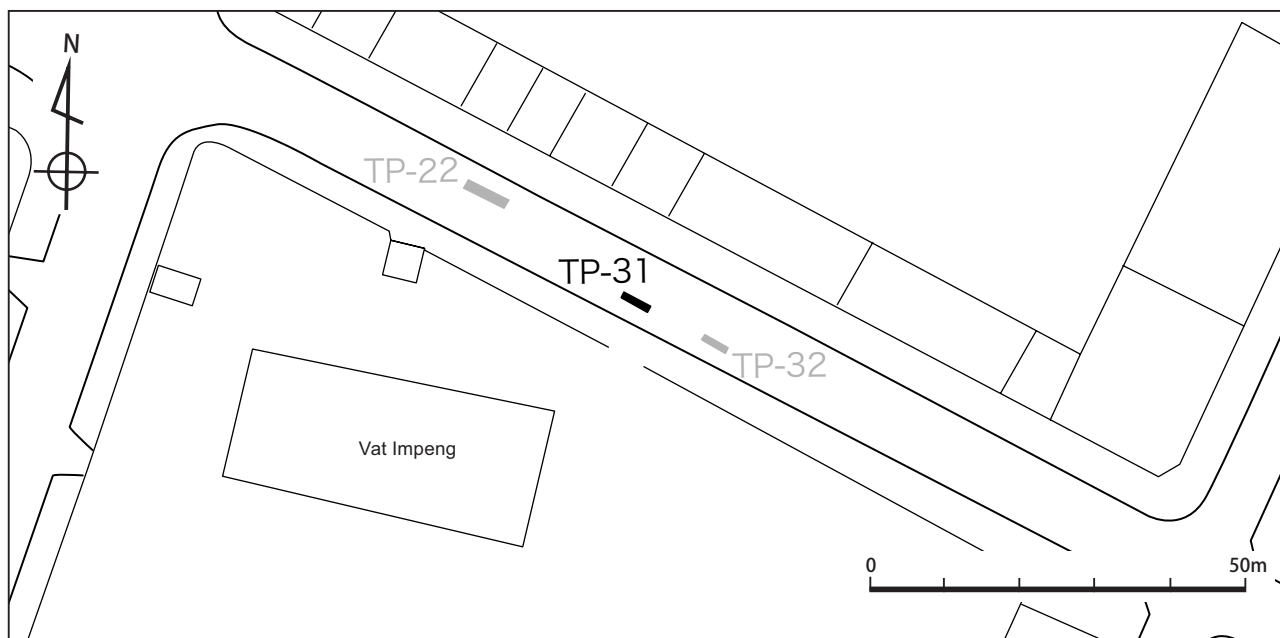
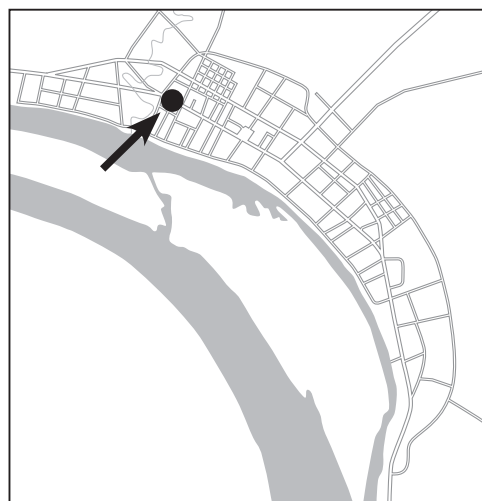

**Point E31-5**  
Coordinates:  
X=87,171.737  
Y=46,124.165  
EL=170.43m

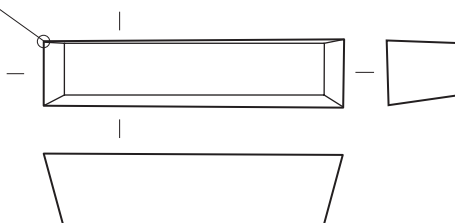

### Test Pit Dimention (max.)

Length: 3.98m

Width: 0.9m

Depth: 0.98m

Surface Area: 3.58m<sup>2</sup>

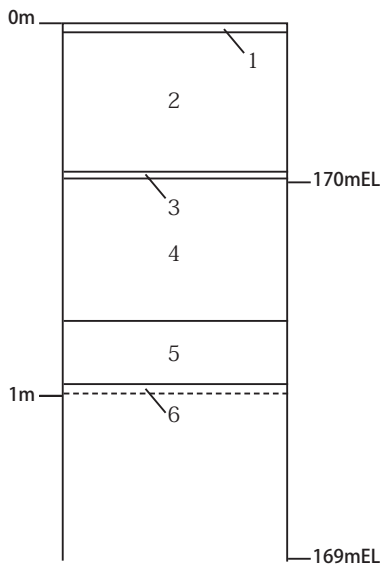

**Explanation of Soil Layers**

- 1 Asphalt: Present road surface.
- 2 Pebble/Laterite soil: Sub-base layer for the present road surface.
- 3 Asphalt: Earlier pavement?
- 4 Brown laterite silt layer. Probably sub-base layer for the earlier road surface.
- 5 Dark grey silty clay. Artifacts found from this layer.
- 6 Grey-brown silty clay: Uniform and with no inclusion.

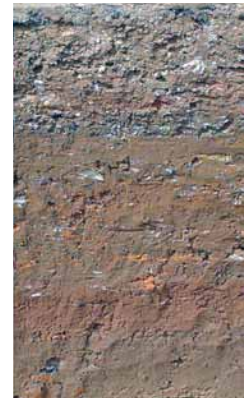

**Structures**

A part of brick structure(?) was detected at west side of this trench (about 90 cm in depth, TP31-ST1). This structure was disturbed by the west wall of trench, and the rest part seemed to continue to outside of trench area. A few fragments of stucco/mortar scattered around this structure. The function of this structure is unidentified.

This brick structure was not dismantled and the trench was refilled by sand.

The discription and drawing in “L’ Art du Laos, par Henri Parmentier. 2 vol., nouvelle édition revue et mise à jour par Madeleine Giteau, Paris, 1988” inform us of the existence of the base of large stupa (that) and temple gate to the north-east of sim. The relation between these structures is unknown at the present time.

**Artifacts**

**Roof tiles**

133 shards of thin flat roof tiles were unearthed. The trace of texture is observed on the one surface of the each of 5 shards. The thickness of these whitish shards are 6 ~ 8 mm.

Width	Thickness
100	47
102	45
108	42
113	55
121	40
150	72

Measurmets of bricks from TP31 (mm)

**Bricks**

16 broken blocks were picked up. Each of 6 blocks of them keeps its width and thickness (see the list below). The natural glaze is on the surface partly of another block.



Site of the excavation



A brick structure TP32-ST1



#### Metal objects

2 bronze fragments of the Buddha image with gold leaf on those surfaces (TP31-M1, M2) and a part of rusted nail were unearthed.

#### Laterite

5 small blocks of laterite were unearthed. The artificial process is not observable, but it is conceivable that these blocks have a relation to the former structures of Vat Inpeng.

#### Stucco/Mortar

18 small blocks of stucco/mortar were unearthed. 1 block of them has molding (TP31-C1).

#### Stoneware

There are relatively less amount of ceramics recovered from the excavation at Test Pit 31. The stoneware shards count only 16 pieces in total. There is no significant or peculiar specimen to be selected for individual reporting with photos. The findings are classified and counted in each shape class as follows; mortar or bowl type wares: five pieces (two shards of rim part, one shard of body, one shard of base part and one shard of rim to base part which proportion seems like a shallow bowl or nearly dish class with flat base), jar type wares: eight pieces (four shards of base part and four shards of body part), oil lamp: one piece of the saucer part, and ash-glazed bowl: two pieces (body parts)

#### Imported ceramics

There are only two pieces of imported ceramics unearthed from the Test Pit 31. One shard is a bowl of Chinese white porcelain (body part) and another is a bowl of Vietnamese under-glaze blue and white ware (body part). Both specimens are so small and fragmentary that it can not be clarified about dating.

#### Earthenware

There are very few, only four pieces of earthenware recovered at the Test Pit 31. All the shards are small and fragmentary, there is no significant specimen to be reported with photos.



TP31-C1



TP31-M1 and M2



# Test Pit 32

Location: Near Vat Impeng. Within the range of old Vat Impeng perimetre.

Excavation Date: August 20, 2004

Identified Working Infrastructure(s): None

Identified Archaeological Feature(s): Alignment of bricks.

Identified Artifacts: 334

Stoneware: 14, Earthenware: 1, Imported ceramics: 7, Stone: 3,

Brick: 54, Metal Object: 3, Stucco/Mortar: 5, Roof Tile: 244

Note: An auxillary Test Pit opened to search for the remain of a stupa of Vat Impeng described in Parmentier's "L'Art du Laos."

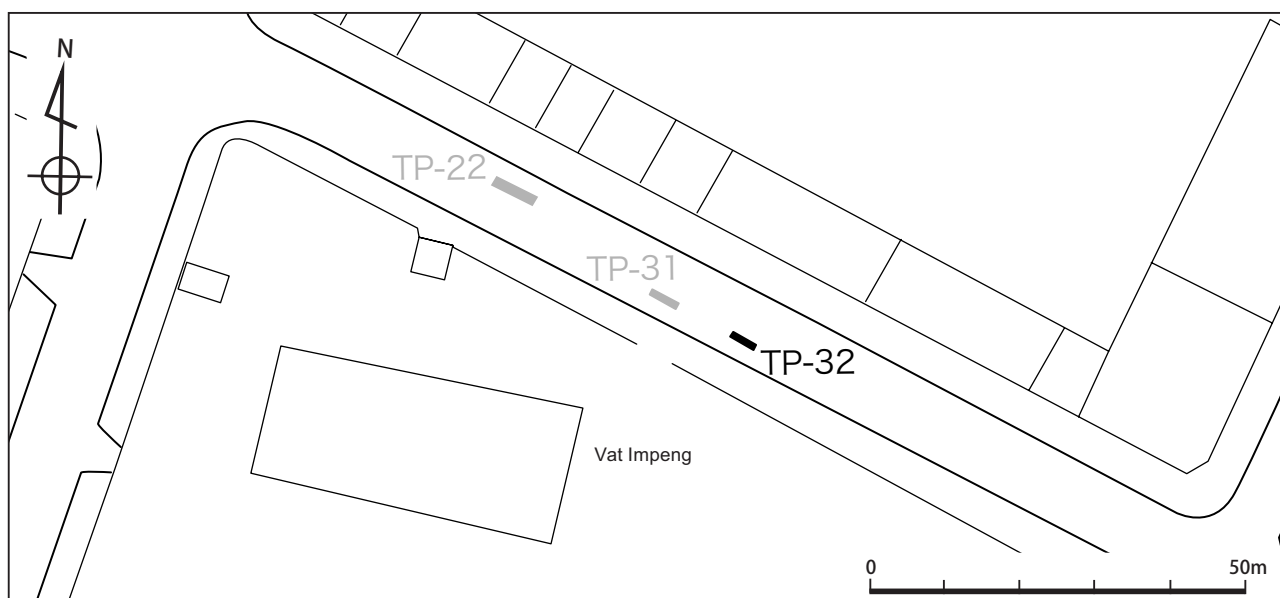
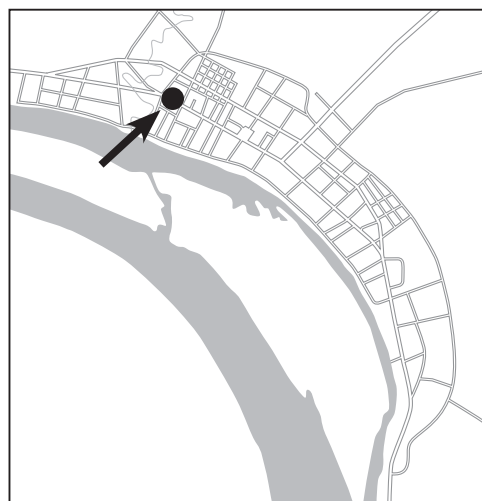

**Point E32-1**  
Coordinates:  
X=88,166.097  
Y=46,134.451  
EL=170.30m

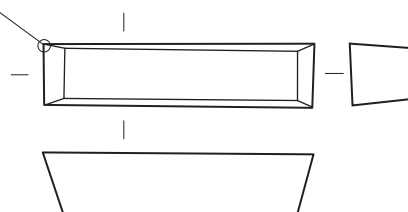

### Test Pit Dimention (max.)

Length: 3.66m

Width: 0.86m

Depth: 0.87m

Surface Area: 3.12m<sup>2</sup>

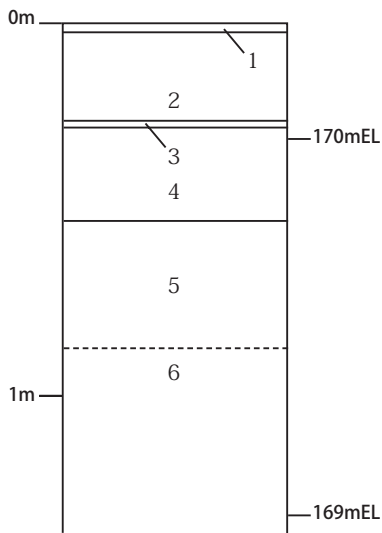

**Explanation of Soil Layers**

- 1 Asphalt: Present road surface.
- 2 Pebble/Laterite soil: Sub-base layer for the present road surface.
- 3 Asphalt: Earlier pavement?
- 4 Brown laterite silt layer. Probably sub-base layer for the earlier road surface.
- 5 Dark grey silty clay. Artifacts found from this layer.
- 6 Grey-brown silty clay: Uniform and with no inclusion.



**Structure**

An alignment of re-used bricks was found. The usage is unknown but likely to be arranged as substitute for the stepping stones.

**Artifacts**

**Roof tiles**

244 shards of flat roof tiles were unearthed. Each 2 shards of them keeps its full width (see the list below, TP32-R1, R2). The trace of texture is observed on the one surface of the each of 4 shards. The thickness of these whitish and grayish shards are 6 ~ 9 mm.

**Bricks**

54 broken blocks were picked up. Each of 18 blocks of them keeps its width and thickness (see the list below). 1 broken part of fan-shaped block (a component of column? TP32-B1) and 2 broken blocks with curved side were included. It is conceivable that these bricks have a relation to the base of large stupa (that) or temple gate mentioned before.

Width	Thickness	Remarks
141	8	A part of front end
144	7	A part of rear end with stopper

**Measurements of rooftiles from TP32 (mm)**

Width	Thickness
89	44
100	42
100	49
102	48
103	51
104	42
105	49
106	56
106	56
108	52
110	50
110	55
117	50
117	63
120	42
122	50
122	56
123	51

**Measurements of bricks from TP32 (mm)**



Site of the Test Pit 32



Alignment of bricks

#### Metal objects

3 small fragments were unearthed.

#### Stucco/Mortar

5 small blocks of stucco/mortar were unearthed.

#### Stoneware

As same as the result at the TP31 mentioned above, there were also quite less amount of ceramics recovered from the excavation at Test Pit 32. The stoneware shards count only 14 pieces in total. There is no significant or peculiar specimen. The findings are classified and counted in each shape class as follows; mortar or bowl typed wares: five pieces (three shards of body and two shards of base part), and jar type wares: nine pieces (two shards of base part and seven shards of body part)

#### Imported ceramics

There are only seven pieces of imported ceramics unearthed from the Test Pit 31. The findings are classified and counted as follows; Chinese underglazed blue and white wares during mainly Qing dynasty: three pieces of bowl (body parts), one piece of basin or plate (base part) and two pieces of small bottle (body parts), polychromatic porcelain probably manufactured in China after modern period: one piece of small bowl or dish (rim part)

TP32-I1 is a base part of Chinese underglazed blue and white ware, probably large plate or basin with tall foot-ring which bottom end is not remained. The paste is nearly white in colour, fine and solid, but slightly powdery with including a lot of black particles. There are light indigo blue coloured decorations painting flowers and several kinds of Buddhism ornaments motifs on the interior and simplified lotus petals motif in "Lama" style on the exterior. The glaze is pale white, translucent and shiny. The characteristic motifs of decorations indicate that the specimen was manufactured in China (possibly Jindezhen kilns) during Ming dynasty or the late of 15th to 16th centuries.

#### Earthenware

Only one piece of earthenware recovered at the Test Pit 32. The shard is a rim part of mortar or deep bowl shaped ware (used as a cooking pot?). Its profile shape is a straight-standing type with thickened edge, which is common to the findings from TP.11 and others reported above.





TP32-R1 and R2



TP32-B1



TP32-I1

