

資料一 1 調査団員・氏名

1. 調査団員氏名、所属

(1) 基本設計調査

氏名	担当業務	現職
新井 和久	総括	国際協力機構 無償資金協力部 業務第三課 課長代理
小柳 桂泉	計画管理	国際協力機構 無償資金協力部 業務第三課
千葉 規矩	業務主任/電力計画/電力系統管理	八千代エンジニアリング(株)
不二葦 教治	発電設備計画I(ディーゼル発電機)	八千代エンジニアリング(株)
西川 光久	燃料装置改造	八千代エンジニアリング(株)
小宮 雅嗣	運営維持管理計画/環境社会配慮	八千代エンジニアリング(株)
松村 昇	発電施設計画	八千代エンジニアリング(株)
宮本 隆幸	調達計画/積算	八千代エンジニアリング(株)
瀬戸 寛仁	配電系統/系統連係	八千代エンジニアリング(株)
山本 壽幸	建築計画	八千代エンジニアリング(株)

(2) 基本設計概要説明調査

氏名	担当業務	現職
三次 啓都	総括	国際協力機構 カンボジア事務所 次長
千葉 規矩	業務主任/電力計画/電力系統管理	八千代エンジニアリング(株)
不二葦 教治	発電設備計画I(ディーゼル発電機)	八千代エンジニアリング(株)
西川 光久	燃料装置改造	八千代エンジニアリング(株)

資料－2 調査行程

2. 調査日程

(1) 基本設計調査

No.	日	曜日	調査内容			宿泊地
			官団員	コンサルタント団員		
			新井団長/小柳	千葉、不二葦、松村、宮本	西川、小宮、瀬戸、山本	
2004年3月						
1	7	日		- 移動[東京→プノンペン JL717 / TG698、10:55/18:45]		プノンペン
2	8	月	-移動[モントルキリ→プノンペン]	- C5 発電所現地調査 - 団内協議		プノンペン
3	9	火	- カンボジア電力公社(Electricite du Cambodge: EDC)表敬、インセプションレポートおよび質問書の提出・説明 - C5 発電所現地調査 - 在カンボジア日本国大使館、JICA カンボジア事務所表敬、調査内容、工程に係る打ち合せ			プノンペン
4	10	水	- EDC と M/D 案協議			プノンペン
5	11	木	- M/D 調印 鉱工業エネルギー省 (Ministry of Industry, Mines and Energy: MIMÉ), EDC - 在カンボジア日本国大使館、JICA カンボジア事務所へ報告			プノンペン
			- 移動[プノンペン→東京 TG699/JL704]	- C5 発電所現地調査		
6	12	金		- 初期環境影響評価(IEIA)手続きに係る打ち合せ(EDC) - C5 発電所現地調査		プノンペン
7	13	土		- 収集資料整理、団内協議		プノンペン
8	14	日		- 収集資料整理、団内協議		プノンペン
9	15	月		- 環境影響評価手続きに係る環境省との協議(Ministry of Environment: MoE) - C5 発電所現地調査		プノンペン
10	16	火		- C5 発電所現地調査 - 環境影響評価手続きに係る EDC との協議		プノンペン
11	17	水		- EDC 電力需要想定、電源開発計画調査 - C5 発電所現地調査 - C5 発電所現況騒音調査		プノンペン
12	18	木		- C5 発電所予算調査 - C5 発電所維持管理計画調査		プノンペン
13	19	金		- C5 発電所要員運転・維持管理能力調査 - C2 発電所調査(水処理、燃料加温方式)		プノンペン
14	20	土		- 収集資料整理、団内協議	- 移動[東京→プノンペン JL717 / TG698、10:55/18:45]	プノンペン
15	21	日		- 収集資料整理、団内協議		プノンペン
16	22	月		- C5 発電所現地調査(電気室、基礎関係) - ADB 援助動向調査		プノンペン
17	23	火		- プノンペン港調査 - 電源開発計画調査(MIMÉ)		プノンペン
18	24	水		- GS-1 変電所調査 - 初期環境影響評価(Initial Environment Impact Assessment: IEIA) 報告書に係る EDC との協議 - 移動[東京→プノンペン、JL717 / TG698](小宮)		プノンペン
19	25	木		- C5 発電所現地調査 - 燃料転換、増設設備に係る EDC との協議		プノンペン

20	26	金		- C5 発電所現地調査 - 燃料転換、増設設備に係る EDC との協議	ブノンペン
21	27	土		- 収集資料整理、団内協議	ブノンペン
22	28	日		- 収集資料整理、団内協議	ブノンペン
23	29	月		- 燃料転換、増設設備に係る EDC との協議 - 電力需給状況調査(EDC 給電指令所)	ブノンペン
24	30	火		- 燃料転換、増設設備に係る EDC との協議	ブノンペン
25	31	水		- フィールドレポート作成 - シアヌークウィル港調査	ブノンペン
2004 年 4 月					
26	1	木		- フィールドレポート作成	ブノンペン
27	2	金		- フィールドレポート作成	ブノンペン
28	3	土		- フィールドレポート作成	ブノンペン
29	4	日		- フィールドレポート作成	ブノンペン
30	5	月		- フィールドレポート説明・協議	ブノンペン
31	6	火		- シアムリアップ発電所運用状況調査	ブノンペン
32	7	水		- フィールドレポート説明・協議、修正、EDC から確認取得	ブノンペン
33	8	木		- フィールドレポート説明(MIME)	ブノンペン
34	9	金		- 在カンボジア日本国大使館、JICA カンボジア事務所へ報告- - 関係機関への帰国挨拶 - 移動[ブノンペン→バンコク→東京、TG-699/JL-704]	機中泊
35	10	土		- 東京着(06:45)	-

(2) 基本設計概要説明調査

No.	日	曜日	調 査 内 容		宿 泊 地
			官団員 三次団長	コンサルタント団員 千葉、西川、不二葦	
2004 年 7 月					
1	11	日	—	- 移動[東京→ブノンペン JL717 / PG926、11:00/19:35]	ブノンペン
2	12	月	—	- JICA カンボジア事務所、MIME、EDC 表敬訪問 - 基本設計概要書、機材仕様書(案)の提出、説明、協議	ブノンペン
3	13	火	—	- 基本設計概要書、機材仕様書(案)の説明、協議	
4	14	水	—	- 基本設計概要書、機材仕様書(案)の説明、協議 - 現地調査(重量機材荷降し場所、輸送ルート調査)	ブノンペン
5	15	木	- EDC と M/D 案協議	- EDC と M/D 案協議 - C5 発電所現地調査	ブノンペン
6	16	金	- EDC と M/D 案修正 - M/D 署名		ブノンペン
7	17	土	—	- 現地調査(C5 発電所、ブノンペン市場調査)	ブノンペン
8	18	日	—	- 収集資料整理、団内協議	ブノンペン
9	19	月	—	- 在カンボジア日本国大使館、JICA カンボジア事務所へ報告- - 関係機関への帰国挨拶 - 移動[ブノンペン→バンコク→東京、TG-699/JL-704]	機中泊
10	20	火	—	- 東京着(06:45)	-

資料－3 関係者(面会者)リスト

3. 相手国関係者リスト

所属及び氏名

職位

鉱工業エネルギー省 (Ministry of Industry, Mines and Energy: MIME)

Mr. Ith Praing	Secretary of State
Mr. Victor Jona	Deputy director, Department Energy Development

カンボディア電力公社 (Electricite du Cambodge: EDC)

Mr. Tan Kim Vinn	Managing Director
Mr. Yim Nolson, P. E.	Deputy Managing Director
Mr. Ros Chenda	Executive Director, Generation Department
Mr. Chan Sodavath	Acting Executive Director, Corporate Planning & Projects
Mr. Chhim Man	Project Manager/Chief, Corporate Planning & Projects
Mr. Houg Chantha	Head of Technical Office, Corporate Planning & Projects
Ms. Mok Phoumy	Head of Construction Section, Technical Office
Mr. Phung Tolany	Deputy Head of Project Management Office 1
Mr. Mao Visal	Deputy Head of Planning, Corporate Planning & Projects
Mr. Khlaut Ranny	Director of C5 & C6
Mr. Aum Hemrith	Deputy Manager of C5 & C6
Mr. Chhay Phalla	Deputy Manager Technical
Mr. Pean Ratha	Director of Power Station No. II
Mr. Ing Pror Seth	Head of Load Dispatching Center
Mr. Nget Sokhan	Chief of Corporate finance
Mr. Chea Subuddhy	Deputy Director of EDC/ Siem Reap

カンボディア電力庁 (Electricity Authority of Cambodia: EAC)

Mr. Hul Kunnak Vuth	Executive Director
---------------------	--------------------

環境省 (Ministry of Environment: MOE)

Mr. Tea Chup	Director of Environment
Mrs. Chou Sokphany	Director of Environment Impact Assessment

公共事業運輸省 (Ministry of Public Works & Transport: MPWT)

Mr. Leng Thun Yuthea	Director General of Transport
----------------------	-------------------------------

プノンペン港 (Phnom Penh Autonomous Port: PPAP)

Mr. Hei Bavy	Director General
--------------	------------------

シアヌークビル港 (Siem Reap Autonomous Port: SAP)

Mr. Ma Sun Hout	Deputy Director General
-----------------	-------------------------

アジア開発銀行 (Asian Development Bank: ADB)

Mr. Anthony J. Jude	Deputy Head
---------------------	-------------

在カンボディア日本国大使館

地神 一美	参事官
-------	-----

JICA カンボディア事務所

力石 寿郎	所長
増田 親弘	所員
西脇 薫	専門家

資料－4 討議議事録 (M/D)

**Minutes of Discussions
on the Basic Design Study
on the Project for Construction and Improvement of the Diesel Engine Generators
of the EDC C5 Power Plant in the Kingdom of Cambodia**

In response to the request from the Government of the Kingdom of Cambodia (hereinafter referred to as "Cambodia"), the Government of Japan decided to conduct a Basic Design Study on the Project for Construction and Improvement of the Diesel Engine Generators of the EDC C5 Power Plant (hereinafter referred to as "the Project") and entrusted the study to the Japan International Cooperation Agency (hereinafter referred to as "JICA").

JICA sent to Cambodia the Basic Design Study Team (hereinafter referred to as "the Team"), headed by Mr. Kazuhisa Arai, a Deputy Director of the Third Project Management Division of the Grant Aid Management Department, JICA, and is scheduled to stay in the country from March 7 to April 9, 2004.

The Team held discussions with the concerned officials of the Government of Cambodia. In the course of the discussions, both sides have confirmed the main items of described in the attached sheets. The Team will proceed to further works and prepare the Basic Design Study Report.

Phnom Penh, March 11, 2004

新井 久

Kazuhisa Arai
Leader
Basic Design Study Team
Japan International Cooperation Agency

→ Ith Praing

Ith Praing
Secretary of State
Ministry of Industry, Mines and Energy



Tan Kim Vinn
Managing Director
Electricite du Cambodge

ATTACHMENT

1. Objective

The objective of the Project is to improve the C5 Power Plant by installing new diesel engine generators and converting the fuel oil from diesel oil into heavy fuel oil (HFO) of the existing unit No.1 and No.2.

2. Project Site

The site of the Project is shown in Annex-1.

3. Responsible and Implementing Organizations

(1) The responsible ministry is the Ministry of Industry, Mines and Energy (hereinafter referred to as "MIME").

(2) The implementing agency is the Electricite du Cambodge (hereinafter referred to as "EDC").

The organization chart of the implementing agency is shown in Annex-2.

4. Items Requested by the Government of Cambodia

After discussions with the Team, the items described in Annex-3 were finally requested by the Cambodian side (hereinafter referred to as "the Equipment"). JICA will assess the appropriateness of the request and will recommend to the Government of Japan.

5. Japan's Grant Aid Scheme

(1) The Cambodian side understands the Japan's Grant Aid scheme and the necessary measures to be taken by the Government of Cambodia explained by the Team as described in Annex-4.

(2) The Cambodian side will take necessary measures, as described in Annex-5, for smooth implementation of the Project, as a condition for the Japan's Grant Aid to be implemented.

6. Schedule of the study

(1) The consultants will proceed to further studies in Cambodia by April 9, 2004.

(2) JICA will prepare the draft report in English and dispatch a mission to Cambodia in order to explain its contents around the middle of July, 2004.

(3) In case that the contents of the report is accepted in principle by the Government of Cambodia, JICA will complete the final report and send it to the Government of Cambodia by the end of September, 2004.

7. Other Relevant Issues

(1) The Cambodian side shall arrange the budget allocation for undertakings to be done by the Cambodian side described in Annex-5.

(2) The Cambodian side shall tap diesel oil from existing two diesel oil tanks, remove the sludge and clean up the bottom of the tanks before commencement of conversion work of oil supply system from diesel oil to HFO.

(3) The Cambodian side shall prepare diesel oil storage tank(s) necessary for the operation of C6 power station before the oil conversion works of existing C5 diesel oil tanks are commenced.

(4) The Cambodian side shall complete the repair work of existing unit No.1 by the middle of July, 2004.

(5) The Cambodian side shall provide temporary storage yard near the site.

(6) The Cambodian side shall clear the site access road, if necessary.

(7) The Cambodian side shall set a power plant operation plan for a transition period from existing diesel generators to HFO type diesel generators to avoid long term stoppage of power plant

operation.

(8) The Cambodian side informed that any Grant Aid to EDC would be treated as an equity of EDC.

(9) The Cambodian side agreed to use saving of this project to expand the distribution network to supply power to the people with social and economical difficulty.

(10) The Team explained the outline of a new JICA Environmental and Social Considerations Guidelines (hereinafter referred to as "the new JICA Guidelines") to the Cambodian side. The Cambodian side took the new JICA Guideline into consideration, and shall complete the necessary procedures. At least, the Cambodian side shall get an approval for IEIA (Initial Environmental Impact Assessment) from the Ministry of Environment by the end of May, 2004, and if EIA is required, the Cambodian side shall get an approval of EIA by the end of August, 2004.

(11) The Cambodian side requested the consultant service, so called "the Soft Component," for the operation and maintenance on the Equipment as one of the components of the Grant Aid. The Team understands its necessity and will study the detail of the technical training methods and periods. The results will be explained to the Cambodian side in the draft report.

(12) The Cambodian side requested the Team to carry out the counterpart training in Japan on the management of the operation and maintenance of the HFO type diesel generators as a technical cooperation by JICA, and the Cambodian side understands that another official request will be necessary to submit from the Cambodian side to the Japanese side through the JICA Cambodia Office.

(13) The Cambodian side shall submit answers in English to the Questionnaire, which the Team handed to the Cambodian side by March 20, 2004.

(14) The Cambodian side shall provide necessary number(s) of counterpart personnel to the Team during the period of their studies in Cambodia.



Project Site

for
NP

Organization Chart of Implementing Agency (EDC)

• ABBREVIATIONS

- D : Director
- DD : Deputy Director
- C : Chief
- DC : Deputy Chief
- GeneDepartment : Generation Department
- TDDepartment : Transmission and Distribution Department
- ComDepartment : Commercial Department
- FADepartment : Finance and Accounting Department
- CPPDepartment : Corporate Planning and Project Department
- ADMNDepartment : Administration Department
- InAuditDepartment : Internal Audit Department
- D.C.C : Dispatching Command Center
- PMO.I : Project Management Office I
- PMO. II : Project Management Office II
- PPMO : Private Project Management Office
- PMISTO: Planning Management Information System and Tariff Office

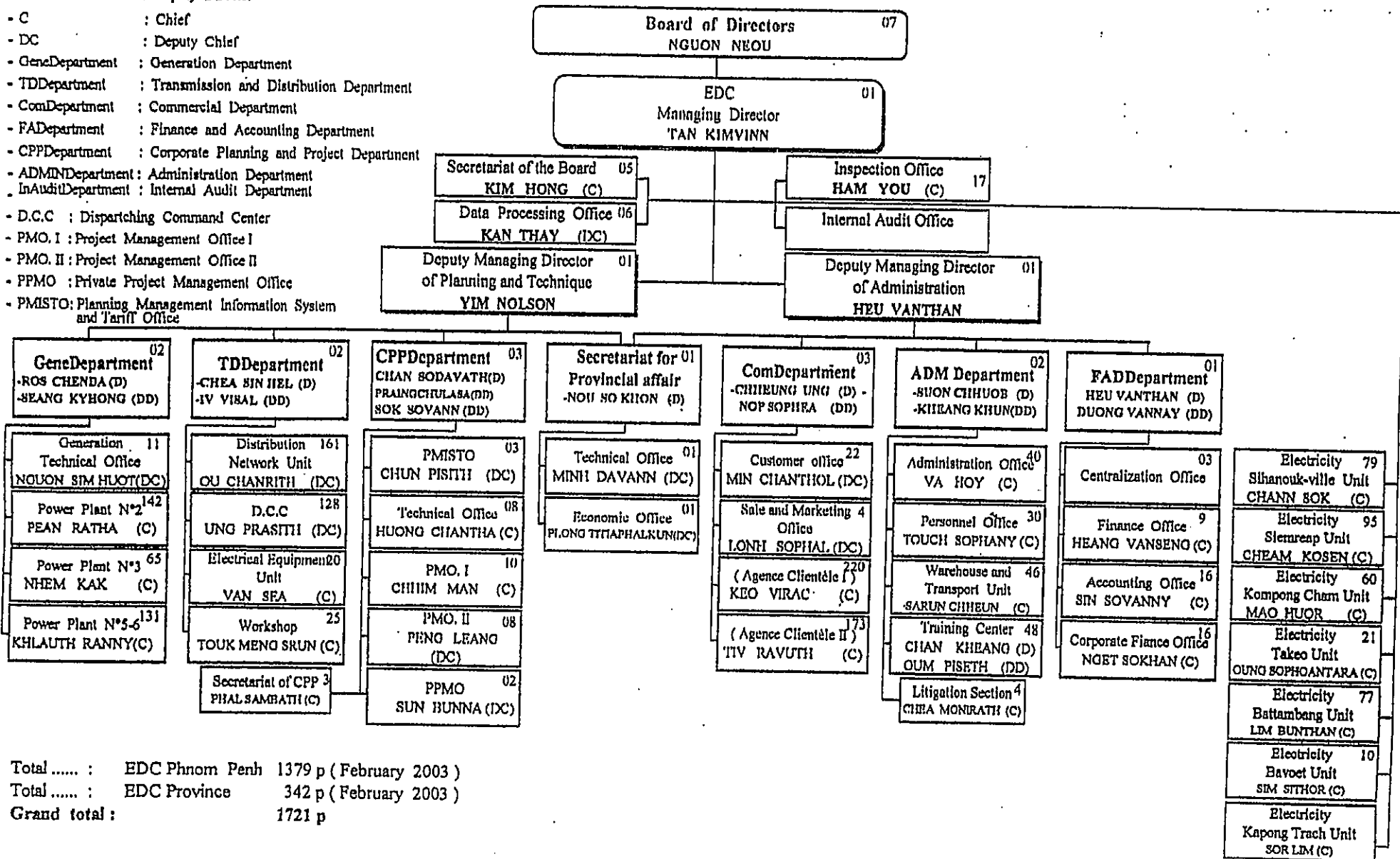

A4-A-5

Total : EDC Phnom Penh 1379 p (February 2003)
 Total : EDC Province 342 p (February 2003)
 Grand total : 1721 p

Handwritten signature/initials

Items Requested by the Government of Cambodia

1. Fuel conversion of existing diesel engine generators from diesel oil to heavy fuel oil

- (1) Supply and installation of One (1) diesel oil tank with relevant capacity.
- (2) Supply and installation of One (1) set of equipment and materials necessary for fuel conversion of existing unit No.1 and No.2.
- (3) Construction of foundation for a diesel oil tank mentioned above.
- (4) Modification of existing two diesel oil tanks to heavy fuel oil tanks

2. Construction of new diesel engine generators

- (1) Supply and installation of Two (2) units of diesel engine generators (DEG) with output capacity of 5,000 kW each.
- (2) Supply and installation of auxiliary and electrical equipment necessary for DEG above.
- (3) Supply and installation of Two (2) step-up transformers (6.3kV/22kV with capacity 6.3 MVA each).
- (4) Supply and installation of Two (2) underground feeder cables connecting from the transformers to the Grid substation about 500m long
- (5) Supply and installation of Four (4) switchgears (Two (2) in Grid substation, Two(2) in Power plant).
- (6) Supply and installation of One (1) set of equipment for cooling water and One (1) set of equipment for water treatment system.
- (7) Construction of the following civil works
 - 1) Foundations of Two (2) DEG and Two (2) step-up transformers.
 - 2) Cable pit for underground feeder cables between step-up transformer and Grid substation.

3. Technical transfer

- (1) Technical transfer of operation and maintenance technique to EDC staff.

Japan's Grant Aid Scheme

The Grant Aid scheme provides a recipient country with non-reimbursable funds to procure the facilities, equipment and services (engineering services and transportation of the products, etc.) for economic and social development of the country under principles in accordance with the relevant laws and regulations of Japan. The Grant Aid is not supplied through the donation of materials as such.

1. Grant Aid Procedures

Japan's Grant Aid scheme is executed through the following procedures.

Application	(Request made by a recipient country)
Study	(Basic Design Study conducted by JICA)
Appraisal & Approval	(Appraisal by the Government of Japan and Approval by Cabinet)
Determination of Implementation	(The Notes exchanged between the Governments of Japan and the recipient country)

Firstly, the application or request for a Grant Aid project submitted by a recipient country is examined by the Government of Japan (the Ministry of Foreign Affairs) to determine whether or not it is eligible for Grant Aid. If the request is deemed appropriate, the Government of Japan assigns JICA (Japan International Cooperation Agency) to conduct a study on the request.

Secondly, JICA conducts the study (Basic Design Study), using (a) Japanese consulting firm(s).

Thirdly, the Government of Japan appraises the project to see whether or not it is suitable for Japan's Grant Aid scheme, based on the Basic Design Study report prepared by JICA, and the results are then submitted to the Cabinet for approval.

Fourthly, the project, once approved by the Cabinet, becomes official with the Exchange of Notes (E/N) signed by the Governments of Japan and the recipient country.

Finally, for the smooth implementation of the project, JICA assists the recipient country in such matters as preparing tenders, contracts and so on.

2. Basic Design Study

1) Contents of the Study

The aim of the Basic Design Study (hereinafter referred to as "the Study"), conducted by JICA on a requested project (hereinafter referred to as "the Project") is to provide a basic document necessary for the appraisal of the Project by the Government of Japan. The contents of the Study are as follows:

- Confirmation of the background, objectives, and benefits of the requested project and also institutional capacity of agencies concerned of the recipient country necessary for the Project's implementation.
- Evaluation of the appropriateness of the Project to be implemented under the Grant Aid scheme from a technical, social and economic point of view.
- Confirmation of items agreed upon by both parties concerning the basic concept of the Project.

**Minutes of Discussions
on the Basic Design Study
on the Project for Construction and Improvement of the Diesel Engine Generators
of the EDC C5 Power Plant in the Kingdom of Cambodia
(Explanation of Draft Final Report)**

In March 2004, the Japan International Cooperation Agency (hereinafter referred to as "JICA") dispatched the Basic Design Study Team on the Project for Construction and Improvement of the Diesel Engine Generators of the EDC C5 Power Plant (hereinafter referred to as "the Project") to the Kingdom of Cambodia (hereinafter referred to as "Cambodia"), and through discussions, field survey, and technical examination of the results in Japan, JICA prepared a draft final report of the study.

In order to explain and to consult with concerned officials of the Royal Government of Cambodia on the components of the draft final report, JICA sent to Cambodia the Draft Report Explanation Team (hereinafter referred to as "the Team"), which is headed by Mr. Hiroto Mitsugi, Deputy Resident Representative, Cambodia Office, JICA from July 11 to July 19, 2004.

As a result of discussions, both sides confirmed the main items described on the attached sheet.

Phnom Penh, July 16, 2004

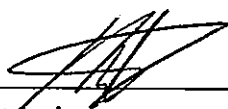

Hiroto Mitsugi
Leader
Basic Design Explanation Team
Japan International Cooperation Agency



Tan Kim Vinn
Managing Director
Electricite du Cambodge

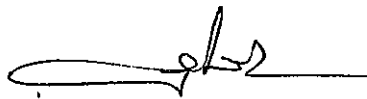

Dr. Ith Praing
Secretary of State
Ministry of Industry, Mines and Energy
The Royal Government of Cambodia

ATTACHMENT

1. Components of the Draft Final Report

The Cambodian side agreed and accepted in principle the components of the draft final report and the draft detailed specifications of the equipment explained by the Team.

2. Japan's Grant Aid Scheme

The Cambodian side understands the Japan's Grant Aid scheme and the necessary undertakings to be taken by the Royal Government of Cambodia as explained by the Team and described in Annex-4 and Annex-5 of the Minutes of Discussions signed by both sides on March 11, 2004.

3. Schedule of the Study

JICA will complete the final report in accordance with the confirmed items and send it to the Royal Government of Cambodia by the end of September, 2004.

4. Other Relevant Issues

- 4-1. The Cambodian side shall tap diesel oil from existing two diesel oil tanks, remove the sludge and clean up the bottom of the tanks before commencement of the fuel conversion work under the Project. Japanese side shall make two months' advance notice of such commencement of the work to the Cambodian side.
- 4-2. The Cambodian side shall prepare diesel oil storage tank(s) necessary for the operation of C6 power station before the fuel conversion works of existing C5 diesel oil tanks are commenced.
- 4-3. The Team confirmed that the Cambodian side already completed the repair work of existing unit No.1 in the C5 power plant on June 17, 2004.
- 4-4. The Team confirmed that the Cambodian side obtained an approval for IEIA (Initial Environmental Impact Assessment) from the Ministry of Environment on June 7, 2004. and EIA is not required for the Project.
- 4-5. The Cambodian side shall provide temporary storage yard near the site.
- 4-6. The Cambodian side shall secure the site access roads from unloading point of the Tonle Sap river to the C5 power station which allow smooth transportation of the equipment and materials under the Project.
- 4-7. The C5 power station shall be shut down during the execution period of the fuel conversion works under the Project. The Cambodian side shall secure power supply capacity by establishing an operation plan of other EDC's power plants and a power purchase plan from IPP. The Cambodian side should prepare and complete the plans by the commencement of the Project.

- 4-8. The Cambodian side agreed to utilize the benefit generated from the Project to improve a living standard of people with social and economical difficulty; such as expanding new power distribution networks to un-electrified areas.
- 4-9. The Cambodian side requested the Team to carry out the counterpart training in Japan on the management of the operation and maintenance of the HFO type diesel generators as a technical cooperation by JICA. The Cambodian side understands that a separate official request for it will be necessary to submit from the Cambodian side to the Japanese side through the JICA Cambodia Office.
- 4-10. The Cambodian side will allocate sufficient budget and qualified staff to appropriately maintain the facilities to be covered by the Project.
- 4-11. The Team handed one (1) copy of the draft detailed specifications of equipment to the Cambodian side and stated that these draft specifications are confidential and should not be duplicated or released to other parties in order to secure the fairness of the tender of the Project.
- 4-12. Electricite du Cambodge (EDC) is considered as an eligible organization for implementing Japan's Grant Aid Project, because the Government has no intention to privatize EDC in the foreseeable future.

資料－5 事業事前計画表（基本設計時）

事業事前計画表(基本設計時)

1. 対象事業名	カンボジア王国 カンボジア電力公社 (EDC) C5 発電所増設及び燃料供給装置改造計画
2. 要請の背景 (協力の必要性・位置付け)	<p>(1) カンボジア国 (以下、「カ」国) の電力系統は長い内戦期間中に大部分が破壊され、国内で電力が供給されているのは全世帯の約 13%、年間消費電力は一人当たり 35kWh で東南アジアでは最も低い水準となっている。更に、発電所の規模が小さい、燃料コストが高い、独立系発電事業者 (Independent Power Producer : IPP) からの電力調達価格が高い (7~13 ¢/kWh) 等の理由から、「カ」国の電気料金単価はアジア地域で最も高い水準にあり、経済発展を阻害する要因の一つとして危惧されている。</p> <p>(2) 一方、国内の電力需要の 9 割を占めるプノンペン市では、急速な経済発展と相まって年率 12% の高い電力需要増加が想定されており、2004 年 4 月現在、発電設備容量不足のためプノンペン周辺地域では毎日 10MW 程度の規模で輪番停電が実施されている。</p> <p>(3) 以上のことから、需要に見合った発電容量の確保と発電原価の低減は、「カ」国電力セクターの喫緊の課題となっている。このような状況の下、「カ」国政府は我が国に対し、発電設備の増設と燃料費削減を目的とした既設発電設備の燃料転換を実施するための無償資金協力を要請した。本計画は「カ」国政府のエネルギー開発計画である CESS (Cambodia Energy Sector Strategy) において、至近年の主要な電源と位置付けられている。</p>
3. プロジェクト全体計画概要 (無償資金協力案件を投入の 1 つとする相手国政府によるプロジェクト全体計画)	<p>下線部：本無償資金協りに直接関係する成果、活動及び投入</p> <p>(1) プロジェクト全体計画の目標 (裨益対象の範囲及び規模)</p> <ol style="list-style-type: none"> 1) プノンペン市に安定した電力が供給される。 2) 削減された EDC の燃料費を原資として、貧困層への裨益を目的とした事業活動が促進される。(電気料金の引き下げ、貧困地域への配電網拡張 等) <p>(裨益対象：プノンペン市民/裨益人口：約 110 万人)</p> <p>(2) プロジェクト全体計画の成果</p> <ol style="list-style-type: none"> 1) プノンペン市の発電設備容量が増加する。 2) プノンペン市の発電原価が低減される。 3) プノンペン市の発電設備の運営・維持管理技術が向上する。 <p>(3) プロジェクト全体計画の主要活動</p> <ol style="list-style-type: none"> 1) <u>出力 5MW のディーゼル発電機 2 台の調達/据付を行う。(新設)</u> 2) <u>既設ディーゼル発電機 (5MW×2 台) の主燃料をディーゼル油から重油に転換するために必要な機材の調達/据付を行う。(燃料転換)</u> 3) <u>重油焚きディーゼル発電機の運転・維持管理に必要な技術訓練を実施する。</u> 4) ディーゼル発電機の運転に必要な人員を増員する。 5) 上記設備の運転・維持管理を実施する。 <p>(4) 投入 (インプット)</p> <ol style="list-style-type: none"> ア. <u>日本側 (本案件)：無償資金協力 17.34 億円</u> イ. 相手国側： <ol style="list-style-type: none"> (ア) 燃料転換および発電設備増設に必要な発電所の清掃・整理と進入道路の確保 (イ) 人員の増員 (ウ) 設備の維持管理に必要な経費

<p>(5) 実施体制 実施機関：カンボジア電力公社（EDC） 主管官庁：鉱工業エネルギー省（MIME）</p>
<p>4. 無償資金協力案件の内容</p>
<p>(1) サイト カンボジア王国プノンペン市</p> <p>(2) 概要 EDC の所有する C5 発電所の既設 1,2 号機の燃料転換（主燃料をディーゼル油から重油に変更）および同発電所への重油焚きディーゼル発電設備の増設（5MW×2 台）に係る機材の調達および据付、並びに技術移転（ソフトコンポーネント）。</p> <p>(3) 相手国側負担事項 燃料転換および発電設備増設に必要な発電所の清掃・整理と進入道路の確保</p> <p>(4) 総事業費 概算事業費 約 17.39 億円（無償資金協力 約 17.34 億円、相手国側 約 0.05 億円）</p> <p>(5) 工期 1) 燃料転換工事：詳細設計期間を含め約 11.5 ヶ月（予定） 2) 発電設備増設工事：詳細設計期間を含め約 15 ヶ月（予定）</p> <p>(6) 貧困、ジェンダー、環境及び社会配慮 NOx、SOx、騒音等による環境への影響が少ない設計とした。</p>
<p>5. 外部要因リスク（プロジェクト全体計画の目標の達成に関するもの）</p>
<p>特に無し</p>
<p>6. 過去の類似案件からの教訓の活用</p>
<p>特に無し</p>
<p>7. プロジェクト全体計画の事後評価に係る提案</p>
<p>(1) プロジェクト全体計画の目標達成を示す成果指標 1) ベースロード用発電設備容量（MW）（現状：28MW→目標：38MW） 2) 計画停電頻度（回 / 日）（現状：平日約 2 回 / 日→目標：0 回 / 日）</p> <p>(2) その他の成果指標 1) 電気料金（リエル / kWh） 2) 配電線延長（km）</p> <p>(3) 評価のタイミング 2007 年（事業終了時）以降</p>

資料－6 参考資料／入手資料リスト

6. 参考資料/入手資料リスト

調査名：カンボジア国カンボジア電力公社（EDC）C5 発電所増設及び燃料供給装置改造計画基本設計調査

番号	資料の名称	形態 図書・ビデオ 地図・写真等	オリジナル・ コピー	発行機関	発行年
1	Second Five Year, Socioeconomic Development Plan (2001-2005)	図書	オリジナル	「カ」国政府	2002年
2	Procedures for Issuing, Revising, Suspending, Revoking or Denying Licenses	図書	コピー	Electricity Authority of Cambodia (EAC)	2002年
3	Electricity Law of The Kingdom of Cambodia	図書	オリジナル	「カ」国政府	2001年
4	General Conditions of Supply of Electricity in the Kingdom of Cambodia	図書	オリジナル	Electricity Authority of Cambodia (EAC)	2003年
5	Cambodia Energy Sector Strategy	図書	コピー	EDC	2003年
6	EDC Annual Report 2002	図書	オリジナル	EDC	2002年
7	EDC Financial Statements for the Year ended 31 December 2000, 2001, 2002	図書	コピー	EDC	2003年
8	EDC Training Center Training Index-Cards 2002-2003	図書	コピー	EDC	2002年
9	EDC Training Center Schedule for Training 2004	図書	コピー	EDC	2000年
10	Seminar Document on The Maximum Load Limit of Transport Vehicle Trafficking on Road Network in Kingdom of Cambodia	図書	コピー	Ministry of Public Works and Transport	1999年
11	Discussion Paper 1: Framework for Power Tariff Regulation in Cambodia	図書	コピー	ADB	2004年
12	Seminar on Environmental Impact Assessment	図書	コピー	Ministry of Environment	2000年

資料－7 電力需給バランス

Power Balance of South Eastern Grid of Cambodia

▽ Target Year of the Project (Please refer page 3-21 for detailed explanation)

ITEMS	YEAR	2000	2001	2002	2003	2004	2005	2006	2007	2008	2009	2010	2011	2012	2013	2014	2015	2016
1. Peak Demand (MW)		66.1	81.6	90.5	103.4	108.0	110.2	112.4	114.6	154.9	222.4	274.9	295.7	324.4	363.8	399.0	437.3	489.7
Kompong Cham											7.3	9.1	14.1	15.4	16.8	18.4	19.9	21.8
Kampot										7.6	13.8	15.2	16.5	17.9	19.4	21.4	23.8	26.3
Phnom Penh (Incl. Kandal and Kompong Speu)		66.1	81.6	90.5	103.4	108.0	110.2	112.4	114.6	140.6	173.8	216.4	227.4	250.0	273.9	301.3	330.9	362.6
Sihanoukville											16.3	20.8	22.2	23.8	33.9	35.7	37.7	51.1
Takeo										6.7	11.2	13.3	15.5	17.3	19.7	22.2	25.0	27.9
Increase rate(%)		-	23.3%	11.0%	14.3%	4.4%	2.0%	2.0%	2.0%	35.2%	43.6%	23.6%	7.6%	9.7%	12.1%	9.7%	9.6%	12.0%
2. Available Capacity (MW)	Installed Capacity																	
2.1 EDC's Power Stations																		
EDC C2	18 MW	15.0	10.0	10.0	10.0	10.0	10.0	5.0	5.0									
EDC C3	15.6 MW	14.0	14.0	14.0	14.0	14.0	10.0	10.0	10.0									
EDC C5 No.1 & No.2	10 MW	10.0	10.0	10.0	10.0	10.0	10.0	10.0	10.0	10.0	10.0	10.0	10.0	10.0	10.0	10.0	10.0	10.0
Emg.DG* ¹	3.8 MW					2.4	2.4	2.4										
No.3 & No.4 (New) * ²	10 MW								10.0	10.0	10.0	10.0	10.0	10.0	10.0	10.0	10.0	10.0
EDC C6	18.6 MW	18.0	18.0	18.0	18.0	18.0	17.0	17.0	17.0	17.0	17.0	17.0	17.0	17.0	17.0	17.0	17.0	17.0
Sihanoukville C/C No.1	30 MW													30.0	30.0	30.0	30.0	30.0
No.2	30 MW														30.0	30.0	30.0	30.0
Kamchai Hydro	120 MW											120.0	120.0	120.0	120.0	120.0	120.0	120.0
Steung Atay Hydro	110 MW																110.0	110.0
Steung Russei Chrum Hydro	125 MW															125.0	125.0	125.0
Sub Total (EDC)	491.0 MW	57.0	52.0	52.0	52.0	54.4	49.4	44.4	52.0	37.0	37.0	157.0	157.0	187.0	217.0	342.0	452.0	452.0
2.2 Power Purchased																		
IPP CUPL	35 MW	28.0	28.0	28.0	28.0	28.0	28.0	28.0	28.0	28.0	28.0	28.0	28.0	28.0	28.0	28.0	28.0	28.0
IPP Jupiter	25 MW	15.0	15.0	15.0	20.0	22.0	22.0											
IPP Kirirom Hydro	12 MW			6.0	6.0	6.0	6.0	6.0	6.0	6.0	6.0	6.0	6.0	6.0	6.0	6.0	6.0	6.0
IPP KEP	30 MW							30.0	30.0	30.0	30.0	30.0	30.0	30.0	30.0	30.0	30.0	30.0
From Vietnam* ³										40.0	150.0	100.0	100.0	100.0	100.0	100.0	100.0	100.0
Sub Total (Power Purchased)		43.0	43.0	49.0	54.0	56.0	56.0	64.0	64.0	104.0	214.0	164.0	164.0	164.0	164.0	164.0	136.0	136.0
2.3 Total Available Capacity (MW) (2.1+2.2)		100.0	95.0	101.0	106.0	110.4	105.4	108.4	116.0	141.0	251.0	321.0	321.0	351.0	381.0	506.0	588.0	588.0
3. Reserve Margin (MW) (2.3-1)		33.9	13.4	10.5	2.6	2.4	-4.8	-4.0	1.4	-13.9	28.6	46.1	25.3	26.6	17.2	107.0	150.7	98.3
(%)		51.2%	16.5%	11.6%	2.5%	2.2%	-4.3%	-3.5%	1.2%	-9.0%	12.9%	16.8%	8.6%	8.2%	4.7%	26.8%	34.5%	20.1%

*1: Emergency Diesel Generators installed at C5 power station will be transferred to rural areas after new diesel generators (No.3 and No.4) of C5 start operation.

*2: Japan's Grant Aid

*3: Power purchase from Vietnam is scheduled to start from year 2007 but at least one year's delay is expected. Maximum contract amount (no obligation) is 200MW.

■ means that reserve margin is lower than 5MW.

Power Balance of Phnom Penh Power System (Phnom Penh city, Kandal and Kompong Speu)

▽ Target Year of the Project (Please refer page 3-21 for detailed explanation)

ITEMS	YEAR	2000	2001	2002	2003	2004	2005	2006	2007	2008	2009	2010	2011	2012	2013	2014	2015	2016	
1. Peak Demand (MW)		66.1	81.6	90.5	103.4	108.0	110.2	112.4	114.6	140.6	173.8	216.4	227.4	250.0	273.9	301.3	330.9	362.6	
Phnom Penh (Incl. Kandal and Kompong Speu)		66.1	81.6	90.5	103.4	108.0	110.2	112.4	114.6	140.6	173.8	216.4	227.4	250.0	273.9	301.3	330.9	362.6	
Increase rate(%)		-	23.3%	11.0%	14.3%	4.4%	2.0%	2.0%	2.0%	22.7%	23.6%	24.5%	5.1%	9.9%	9.6%	10.0%	9.8%	9.6%	
2. Available Capacity (MW)	Installed Capacity																		
2.1 EDC's Power Stations																			
EDC C2	18 MW	15.0	10.0	10.0	10.0	10.0	10.0	5.0	5.0										
EDC C3	15.6 MW	14.0	14.0	14.0	14.0	14.0	10.0	10.0	10.0										
EDC C5 No.1 & No.2	10 MW	10.0	10.0	10.0	10.0	10.0	10.0	10.0	10.0	10.0	10.0	10.0	10.0	10.0	10.0	10.0	10.0	10.0	
Emg.DG* ¹	3.8 MW					2.4	2.4	2.4											
No.3 & No.4 (New) * ²	10 MW								10.0	10.0	10.0	10.0	10.0	10.0	10.0	10.0	10.0	10.0	
EDC C6	18.6 MW	18.0	18.0	18.0	18.0	18.0	17.0	17.0	17.0	17.0	17.0	17.0	17.0	17.0	17.0	17.0	17.0	17.0	
Sihanoukville C/C No.1	30 MW													23.1	22.6	22.7	22.7	22.2	
No.2	30 MW														22.6	22.7	22.7	22.2	
Kamchai Hydro * ³	120 MW											94.5	92.3	92.5	90.4	90.6	90.8	88.9	
Steung Atay Hydro * ³	110 MW																	83.2	81.5
Steung Russei Chrum Hydro * ³	125 MW															94.4	94.6	92.6	
Sub Total (EDC)	491.0	57.0	52.0	52.0	52.0	54.4	49.4	44.4	52.0	37.0	37.0	131.5	129.3	152.6	172.6	267.4	351.0	344.3	
2.2 Power Purchased																			
IPP CUPL	35 MW	28.0	28.0	28.0	28.0	28.0	28.0	28.0	28.0	28.0	28.0	28.0	28.0	28.0	28.0	28.0	28.0		
IPP Jupiter	25 MW	15.0	15.0	15.0	20.0	22.0	22.0												
IPP Kirirom Hydro	12 MW			6.0	6.0	6.0	6.0	6.0	6.0	6.0	6.0	6.0	6.0	6.0	6.0	6.0	6.0	6.0	
IPP KEP	30 MW							30.0	30.0	30.0	30.0	30.0	30.0	30.0	30.0	30.0	30.0	30.0	
From Vietnam* ³ * ⁴										36.3	117.2	78.7	76.9	77.1	75.3	75.5	75.7	74.1	
Sub Total (Power Purchased)		43.0	43.0	49.0	54.0	56.0	56.0	64.0	64.0	100.3	181.2	142.7	140.9	141.1	139.3	139.5	111.7	110.1	
2.3 Total Available Capacity (MW) (2.1+2.2)		100.0	95.0	101.0	106.0	110.4	105.4	108.4	116.0	137.3	218.2	274.2	270.2	293.6	311.9	406.9	462.7	454.4	
3. Reserve Margin (MW) (2.3-1)		33.9	13.4	10.5	2.6	2.4	-4.8	-4.0	1.4	-3.3	44.4	57.8	42.8	43.7	37.9	105.6	131.8	91.7	
(%)		51.2%	16.5%	11.6%	2.5%	2.2%	-4.3%	-3.5%	1.2%	-2.4%	25.6%	26.7%	18.8%	17.5%	13.8%	35.0%	39.8%	25.3%	

*1: Emergency Diesel Generators installed at C5 power station will be transferred to rural areas after new diesel generators (No.3 and No.4) of C5 start operation.

*2: Japan's Grant Aid

*3: About 74-79% of available capacity will be allocated to Phnom Penh Power System by prorating peak demand of Phnom Penh Power System and South Eastern Grid.

*4: Power purchase from Vietnam is scheduled to start from year 2007 but at least one year's delay is expected. Maximum contract amount (no obligation) is 200MW.

■ means that reserve margin is lower than 5MW.

資料一 8 初期環境影響評估報告書

**THE PROJECT
FOR
CONSTRUCTION AND IMPROVEMENT
OF
THE DIESEL ENGINE GENERATORS OF THE EDC C5 POWER PLANT
IN
THE KINGDOM OF CAMBODIA**

**INITIAL ENVIRONMENTAL IMPACT ASSESSMENT REPORT
(IEIA)**

APRIL 2004

Electricité du Cambodge (EDC)

**JICA BASIC DESIGN STUDY TEAM
(Yachiyo Engineering Co., Ltd.)**

CONTENTS

1. General.....	1
1.1 Project Description	1
1.2 Rationale of the Environmental Study.....	1
1.3 Objectives and Strategies.....	2
1.4 National Policy on the Environment in Cambodia	2
2. Initial Environmental Study	3
2.1 Environmental Items to be studied	3
2.1.1 Meteorology	3
2.1.2 Topography and geology	3
2.1.3 Underground water	3
2.1.4 Flora and fauna	4
2.2 Results of Initial Environmental Examination.....	4
2.2.1 Air Pollution by NO ₂ and SO ₂	4
2.2.2 Noise disturbance	5
3. Environmental Management Plan.....	7
4. Conclusion	8
Attachment	
Annex-1 Location of Project Site.....	9
Annex-2 Formula to calculate the pollution intensity of NO ₂ and SO ₂	10
Annex-3 Calculation of the pollution intensity of NO ₂ and SO ₂	11
Annex-4 Noise prediction points and results	14
Annex-5 Calculation of noise level	15

1. General

To cope with tight power supply and demand balance and to improve EDC's serious financial status, the Government of Cambodia (GOC) requested Grant Aid from the Government of Japan (GOJ) on "the Project for Construction and Improvement of the Diesel Engine Generators of the EDC C5 Power Plant in the Kingdom of Cambodia" (hereinafter, referred to as the Project).

Upon a request of the GOC, the Japan International Cooperation Agency (JICA) conducted a Basic Design Study to examine viability of the Project. This Initial Environmental Impact Assessment (IEIA) report was prepared based on the results of the Basic Design Study to assess possible environmental impact caused by the Project.

1.1 Project Description

The Project aims;

- To convert fuel oil used for existing two diesel engine generator units No.1 and No.2 (5MW each) from Diesel Oil to Heavy Fuel Oil (HFO).
- To install two additional diesel engine generators units No.3 and No.4 (5MW each) that can use HFO.

The Project site, i.e. EDC C5 Power Plant is located at the north end of Phnom Penh city and about 3.2 km apart from the Loyal Palace. The location of the project site is shown in Annex-1 and location of diesel engine generators in C5 power station is shown in Annex-4.

1.2 Rationale of the Environmental Study

The Project is not likely to give any significant impacts to the environment around the project site area if the project components and development scale are taken into consideration. However, sub-decree on Environmental Impact Assessment Process in the Kingdom of Cambodia (No. 72. ANRK, BK August 11, 1999) requires that project owner who is planning to construct a power plant with the capacity more than 5MW shall conduct Initial Environmental Impact Assessment (IEIA).

Consequently, the Environmental Study (the Study) is conducted as an IEIA level by focusing on two project components which might give adverse environmental impacts, namely the fuel conversion from diesel oil to HFO and installation of two additional diesel engine generators.

1.3 Objectives and Strategies

The principal objectives of the Study are;

- to clarify environmental impacts caused by the fuel conversion and installation of the diesel engine generators at C5 power station,
- to evaluate environmental impact, and
- to propose countermeasures, if any

To achieve the objectives mentioned above, the following works are conducted in the Study;

- to collect and review relevant data and documents related to environmental aspects of the Project including related laws and regulations in Cambodia.
- to carry out a field survey of the existing Project site for checking environmental sensitivity of the Project.
- to evaluate the magnitude of impact preliminarily and to prepare the study report.

The results of the Study shall provide necessary data and information to formulate environmentally sound project design and environmental management plan to cope with possible impacts caused by the Project.

1.4 National Policy on the Environment in Cambodia

The Government of Cambodia issued “The Law on Environmental Protection and Natural Resource Management” on January 1997.

The purposes of the Law are;

- to protect [and] improve environmental quality and public health through the prevention, reduction and control of pollution
- to assess the environmental impact of all proposed projects prior to the issuance of a decision by the GOC
- to ensure the rational and sustainable conservation, management and use of the natural resources of the GOC
- to encourage and enable the public to participate in environmental protection and natural resource management
- to suppress any acts that cause harm to the environment

The environmental study is carried out based on the above Law.

2. Initial Environmental Study

2.1 Environmental Items to be studied

According to the Law on Environmental Protection and Natural Resource Management, a lot of environmental items shall be taken into consideration for the Project. However, most of them will not always be necessary, nor give significant impact due to the characteristics, components and scale of the Project.

The followings items are the key points of selecting environmental items to be studied in this Initial Environmental Impact Assessment (IEIA).

(1) Meteorology

The climate of the Project area, i.e. Phnom Penh city, is strongly monsoonal. The cooler dry northeast monsoon (November to March) follows after the southwest monsoon with higher winds, humidity and most of year's rainfall. Daily mean temperature at the Project site varies from about 24 °C in December and January to 29 °C in April. Average rainfall is about 1,400mm.

(2) Topography and geology

Phnom Penh city is on plain just at the connection of the Mekong River and the Tonle Sap River. The plain is flat and about 10m in elevation. The Project Site locates at the north edge of Phnom Penh city. East side of the site is 500m apart from the Tonle Sap River, north and west sides are industrial area and Boeng Kak Lake, and its south side is government and business area.

Since the Project will be implemented completely inside the premises of the existing C5 power station, displacement of the local peoples and houses will not be required. Besides, the Project site is located apart enough distance from the city center and Royal Palace in the city.

Thus, the environmental impacts related to the Project area would not be significant, and the Project is not situated in an environmentally sensitive area.

(3) Underground water

The cooling water system of the existing two diesel engine generators (unit No.1 and No.2) will not be changed by the fuel conversion work. A closed circulation radiator type will be selected for the cooling water system of the two new diesel engine generators (unit No.3 and No.4). Steam boilers and / or electrical heater are used for heating HFO. Therefore, underground water will not be used for the existing and additional diesel engine generators,

and a little amount of water (4-5m³/day) supplied from city water system will be used to make up loss of cooling water. In case steam boilers are applied for HFO heating system, blown water from boiler will be treated to be neutral. All drainage water from power plant is collected to the oily-water separator pit to separate oil from water. Therefore, water pollution and impact on the social environmental in the surrounding of the power station, especially for underground water, will not be expected.

(4) Flora and Fauna

There are rich fisheries in the Tonle Sap River and Mekong River. About 100 mammals and 400 bird species inhabit all around Cambodia. A number of these are listed in international endangered species list (17 species of endangered mammals and 24 species of endangered birds). However, none of them has been recorded in the vicinity of the Project area. In addition, there are no natural or near natural forests within 3 km of the Project area.

Considering the given conditions mentioned above and general project feature, it is considered that the Project is not environmentally sensitive. The possible environmental impacts to be studied are eventually three items during the operation stage, namely;

- i) Air pollution by NO₂
- ii) Air pollution by SO₂, and
- iii) Noise

2.2 Results of Initial Environmental Examination

2.2.1 Air pollution by NO₂ and SO₂

There are existing two diesel engine generators with the capacity of 5MW each (units No.1 and No.2, 10MW in total) in EDC's C5 power station. Two of new additional diesel engine generators with the capacity of 5MW each (units No.3 and No.4, 10 MW in total) will be installed at existing C5 power station. After the completion of the Project, the total generating capacity of C5 power station will be 20MW (5 MW×4).

The future NO₂ and SO₂ concentration in ambient air around C5 power station after completion of the Project (with total generating capacity of 20MW) is predicted by Sutton's calculation formula as shown in Annex-2 and Annex-3.

(1) Prediction of NO₂

The maximum ground concentration of NO₂ would appear at the point of 1,285m apart from the pollution source. The method of prediction is shown in Annex-2 and 3 and the results of

the calculation are shown in Table 2.2-1 below.

Table 2.2-1 The maximum ground concentration of NO₂

(mg/Nm³)

	Air Quality Standards of Cambodia	Predicted Value
1 hour mean value	0.3	0.1127
24 hours mean value	0.1	0.0434

The predicted NO₂ concentration is fairly low compared to the standard of Cambodia. Thus, no significant impact to the ambient air is expected by NO₂ emission from the C5 power station.

(2) Prediction of SO₂

The maximum ground concentration of SO₂ would appear at the point of 1,285m apart from the pollution source. The method of prediction is shown in Annex-2 and 3 and the results of the calculation are shown in Table 2.2-2 below.

Table 2.2-2 The maximum ground concentration of SO₂

(mg/Nm³)

	Air Quality Standards of Cambodia	Predicted Value
1 hour mean value	0.5	0.0824
24 hour mean value	0.3	0.0317
1 year mean value	0.1	0.0054

The predicted SO₂ concentration is fairly low compared to the standard of Cambodia. Thus, no significant impact to the ambient air is expected by SO₂ emission from the C5 power station.

2.2.2 Noise disturbance

When the two additional diesel engine generators (units No.3 and No.4) start operation, noise level generated from C5 power station will increase. Noise level after completion of the Project is calculated and the impact of the noise is assessed in this section.

(1) Prediction Points

Ten prediction points are set on the south, east and north boundary of C5 power station. On the west side of C5 power station, there is a huge land that is occupied by former C4 power station and it is not likely to give any noise disturbance to the residents living in this direction. The prediction points are shown in Annex-4.

(2) Noise level at the source

In general diesel power stations, major facilities which generate high level of noise are diesel engine generators and radiators.

Actual noise level of the existing diesel engine generator of C5 is 94 dB(A), which is measured at outside power house one meter apart from the wall. Since the additional diesel engine generators (units No.3 and No.4) to be installed in this project have the same generating capacity as the existing ones, noise level of a diesel engine which is used for noise level prediction is to be 94 dB(A).

Regarding radiators, according to general specifications of mechanical manufacturer, noise level of a radiator which is used for a diesel engine generator with the capacity of 5MW is 87 dB(A) at the source.

(3) Noise Level Prediction

The method of noise level prediction is shown in Annex-5. The results of the calculation are shown in Annex-4 and Table 2.2-3 below. According to the prediction, the maximum noise level at the boundary of C5 power station which is calculated as combined noise of diesel engine generators and radiators is 65 dB(A).

Table 2.2-3 Predicted Noise Level at the Boundary

Prediction Point	Noise Level (dB (A))	Remarks
1	61	South side of the boundary
2	62	South side of the boundary
3	61	South side of the boundary
4	65	East side of the boundary
5	63	East side of the boundary
6	65	East side of the boundary
7	63	East side of the boundary
8	60	North side of the boundary
9	62	North side of the boundary
10	62	North side of the boundary

(4) Evaluation

According to Sub-Decree on Air Pollution and Noise Disturbance in the Kingdom of Cambodia maximum allowable noise level in public and residential area is set force as shown in Table 2.2-4.

The area around C5 power station is considered to be “**Small industrial factories intermingling in residential areas**” because there are existing C5 power station, C6 power

station and former C1 power station (currently IPP Jupiter) around the area.

Predicted noise levels at the boundary of C5 are fairly low compared to the standard except for time period from 10pm to 6am when the maximum allowable noise level is 50dB(A). However, C5 power station will not be operated during midnight (from 10pm to 6am) because enough power supply capacity will be reserved in that time period. According to the latest daily power demand curve in Phnom Penh city, power demand in the midnight reduces from 50 to 80% of peak demand which occurs around 7pm. Currently, existing diesel engine generators of C5 power station are not operated in the midnight and it is expected that the same kind of operation mode will be applied even after completion of the Project. Consequently, this project will not give severe noise impact to the environment.

**Table 2.2-4 Maximum allowable noise level in public and residential area
(Sub- decree on Air Pollution and Noise Disturbance in Cambodia)**

N°	Area	Period of time		
		From 6am to 6pm	From 6pm to 10pm	From 10pm to 6am
1	Quiet areas - Hospitals - Libraries - School - Kindergarten	45	40	35
2	Residential area: - Hotels - Administration offices - House	60	50	45
3	Commercial and service areas and mix	70	65	50
4	Small industrial factories intermingling in residential areas	75	70	50

3. Environmental Management Plan

EDC shall implement the following Environmental Management Plan (EMP) to ensure that environmental impact brought by the Project will conform to the IEIA as well as the Cambodian Environmental Standard in subsequent stages of the Project.

[Environmental Management Plan]

- (1) EDC shall establish an environmental section within EDC's organization and assign staffs who will supervise environmental compliance of generating facilities.
- (2) EDC shall maintain its generating facilities in good condition so that the emission levels of the facilities will not exceed the value guaranteed by manufacturers.
- (3) EDC shall monitor and record noise levels at boundary periodically.

(4) EDC shall procure heavy fuel oil of less sulfur content which is available in Cambodia as much as possible.

4. Conclusion

Since the Project will be implemented in the premises of the existing C5 power station, resettlement of local people is not required. As explained in section 2.1 and 2.2 there is no endangered species and area that should be protected around project site.

According to the study of environmental impact prediction on NO₂, SO₂ and noise, air pollutant and noise level which are generated from C5 power station is fairly lower than the environmental standards in Cambodia. Moreover, no complaints were found through the inquiry survey to the local people who were living around existing C5 power station.

Thus it is concluded that environmental impact brought by the Project is minimal and acceptable.

Annex-1

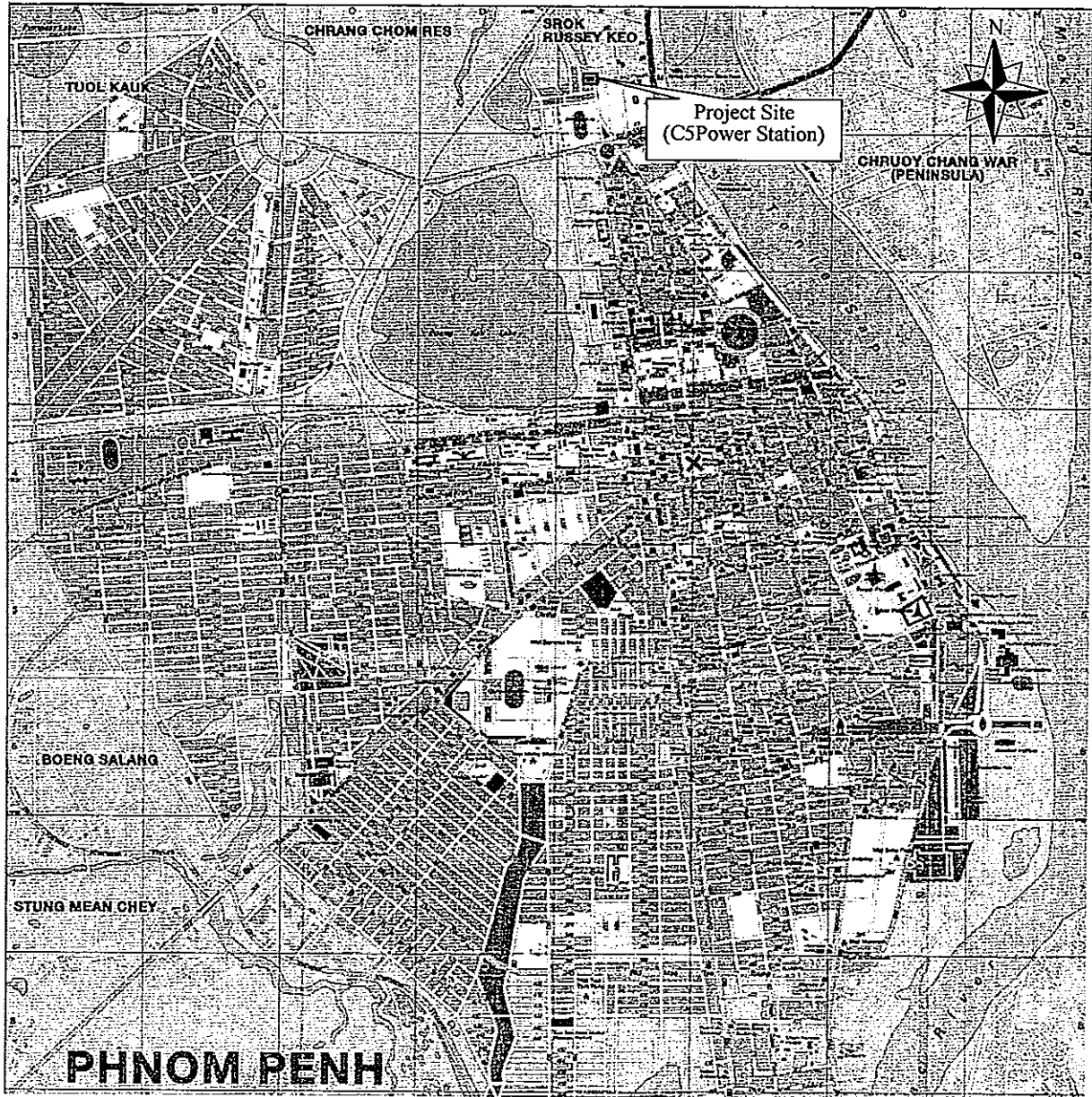

Project Site

Formula to calculate the pollution intensity of NO₂ and SO₂

The Sutton's calculation formulas of the smoke dispersion are as follows:

- (1) Effective height of Exhaust port

$$H_e = H_0 + 0.65(H_m + H_t)$$

$$H_m = 0.795 (QV)^{1/2} / (1 + 2.58/V)$$

$$H_t = 2.01 \times 10^{-3} Q(T-288)(2.30 \log J + 1/J - 1)$$

$$J = \{1/(QV)^{1/2}\} \{1460 - 296 \times V/(T-288)\} + 1$$

- (2) Maximum ground concentration of SO₂ and NO₂ and the distance to the position of the maximum ground concentration

$$C_{\max} = 1.72 \times q/H_e^2 \times n$$

$$X_{\max} = 20.8 \times H_e^{1.143}$$

Here

H_e = Effective height of Exhaust port (m)

H₀ = Actual height of Exhaust port (m)

Q = Quantity of exhaust gas at 15°C for one unit (m³/sec)

V = Exhaust gas velocity at exhaust port (m/sec)

n = Number of unit

q = Quantity of NO₂ and SO₂ in the exhausted gas for one unit (Nm³/hr)

C_{max} = Maximum ground concentration of NO_x and SO_x by C5 power plant (Three minutes mean value) (ppm)

X_{max} = Distance from the exhaust port to the position of the maximum ground concentration (m)

And

For NO₂ Maximum ground concentration

$$C_{\max}' = 2.054 \times C_{\max} \quad (\text{mg/Nm}^3)$$

For SO₂ Maximum ground concentration

$$C_{\max}' = 2.855 \times C_{\max} \quad (\text{mg/Nm}^3)$$

Calculation of the pollution intensity of NO₂ and SO₂

There are existing two diesel engine generators with the capacity of 5MW each (units No.1 and No.2, 10MW in total) in EDC's C5 power station. Two of additional diesel engine generators with the capacity of 5MW each (units No.3 and No.4, 10 MW in total) will be installed at existing C5 power station. After the completion of the Project, the total generating capacity of C5 power station will be 20MW (5 MW×4). Calculation of pollution intensity of NO₂ and SO₂ are shown below.

1. Pollution Intensity of NO₂

Number of Diesel Engine Generators (n)		4 (unit)
Output of each Diesel Engine Generator (Q)		5,000 (kW)
Quantity of exhaust gas of each Diesel Engine Generator		28,040 (Nm ³ /hr)
Temperature of exhaust gas	(Celsius Degree)	365 (°C)
	(Kelvin)	365 + 273 = 638 (K)
Density of NO ₂ in the exhaust gas		950 (ppm)
Actual height of exhaust port	(H ₀)	16 (m)

[Calculation]

(1) Quantity of exhaust gas at 15°C

$$Q = 28,040 / 3,600 \times (273 + 15) / 273 = 8.217 \quad (\text{m}^3/\text{sec})$$

(2) Quantity of NO₂ in the exhausted gas

$$q = 950 \times 10^{-6} \times 28,040 = 26.64 \quad (\text{Nm}^3/\text{s})$$

(3) Exhaust port Area

$$\text{Diameter of exhaust port} = 854.6 \quad (\text{mm})$$

$$A = \pi / 4 \times 0.8546^2 = 0.5736 \quad (\text{m}^2)$$

(4) Exhaust gas velocity at exhaust port

$$V = Q / A \times (273 + 365) / (273 + 15) = 31.74 \quad (\text{m}/\text{sec})$$

(5) $J = 1 / (QV)^{1/2} \{1460 - 296 \times V / (T - 288)\} + 1$

$$= \{1 / (8.217 \times 31.74)^{1/2}\} \times \{1460 - 296 \times 31.74 / (638 - 288)\} + 1$$

$$= 89.74 \quad (\text{m})$$

(6) $H_m = 0.795 (QV)^{1/2} / (1 + 2.58/V)$

$$= 0.795 \times (8.217 \times 31.74)^{1/2} / (1 + 2.58/31.74)$$

$$= 11.87 \quad (\text{m})$$

(7) $H_t = 2.01 \times 10^{-3} Q(T - 288)(2.30 \log J + 1/J - 1)$

$$= 2.01 \times 10^{-3} \times 8.217 \times (638 - 288) (2.30 \log 89.74 + 1/89.74 - 1)$$

$$=20.25 \quad (\text{m})$$

(8) $H_e = H_0 + 0.65(H_m + H_t)$
 $= 16 + 0.65(11.87 + 20.25) = 40.88 = 36.88 \quad (\text{m})$

(9) $C_{\max} = 1.72 \times q / H_e^2 \times n$
 $= 1.72 \times 26.64 / 36.88^2 \times 4$
 $= 0.1348 \quad (\text{ppm})$

(10) $X_{\max} = 20.8 H_e^{1.143} = 20.8 \times 36.88^{1.143}$
 $= 1,285 \quad (\text{m})$

(11) 3 minutes mean value
 $C_{\max}' = 2.054 \times C_{\max} = 2.054 \times 0.1348 = 0.2769 \quad (\text{mg/Nm}^3)$

(12) 1 hour mean value
 $C_{\max}'(1) = (3/60)^{0.3} \times C_{\max}' = 0.407 \times 0.2769 = 0.1127 \quad (\text{mg/Nm}^3)$

(13) 24 hours mean value
 $C_{\max}'(24) = (1/24)^{0.3} \times C_{\max}'(1) = 0.385 \times 0.1127 = 0.0434 \quad (\text{mg/Nm}^3)$

2. Pollution Intensity of SO₂

Number of Diesel Engine Generators (n)	4 (unit)
Output of each Diesel Engine Generator (Q)	5,000 (kW)
Quantity of exhaust gas of each Diesel Engine Generator	28,040 (Nm ³ /hr)
Temperature of exhaust gas (Celsius Degree)	365 (°C)
(Kelvin)	365 + 273 = 638 (K)
Content of Sulfur in the fuel oil	2 (%)
Density of SO ₂ in the exhaust gas	500 (ppm)
Actual height of exhaust port (H ₀)	16 (m)

Calculation

(1) Quantity of exhaust gas at 15°C
 $Q = 28,040 / 3,600 \times (273 + 15) / 273 = 8.217 \quad (\text{m}^3/\text{sec})$

(2) Quantity of SO₂ in the exhausted gas
 $q = 500 \times 10^{-6} \times 28,040 = 14.02 \quad (\text{Nm}^3/\text{hr})$

(3) Exhaust port Area
Diameter of exhaust port = 854.6 (mm)
 $A = \pi / 4 \times 0.8546^2 = 0.5736 \quad (\text{m}^2)$

(4) Exhaust gas velocity at exhaust port
 $V = Q / A \times (273 + 365) / (273 + 15) = 31.74 \quad (\text{m}/\text{sec})$

(5) $J = 1 / (QV)^{1/2} \{1,460 - 296 \times V / (T - 288)\} + 1$

$$= \{1/(8.217 \times 31.74)^{1/2}\} \times \{1,460-296 \times 31.74/(638-288)\} + 1$$

$$= 89.74 \quad (m)$$

(6) $H_m = 0.795 (QV)^{1/2} / (1 + 2.58/V)$

$$= 0.795 \times (8.217 \times 31.74)^{1/2} / (1 + 2.58/31.74)$$

$$= 11.87 \quad (m)$$

(7) $H_t = 2.01 \times 10^{-3} Q(T-288)(2.30 \log J + 1/J - 1)$

$$= 2.01 \times 10^{-3} \times 8.217 \times (638-288) (2.30 \log 89.74 + 1/89.74 - 1)$$

$$= 20.25 \quad (m)$$

(8) $H_e = H_0 + 0.65(H_m + H_t)$

$$= 16 + 0.65(11.87 + 20.25)$$

$$= 36.88 \quad (m)$$

(9) $C_{max} = 1.72 \times q/H_e^2 \times n$

$$= 1.72 \times 14.02/36.88^2 \times 4$$

$$= 0.07092 \quad (ppm/unit)$$

(10) $X_{max} = 20.8 H_e^{1.143} = 20.8 \times 36.88^{1.143}$

$$= 1,285 \quad (m)$$

(11) 3 minutes mean value

$$C_{max}' = 2.855 \times C_{max} = 2.855 \times 0.07092 = 0.2025 \quad (mg/Nm^3)$$

(12) 1 hour mean value

$$C_{max}'_{(1)} = (3/60)^{0.3} \times C_{max}' = 0.407 \times 0.2025 = 0.0824 \quad (mg/Nm^3)$$

(13) 24 hours mean value

$$C_{max}'_{(24)} = (1/24)^{0.3} \times C_{max}'_{(1)} = 0.385 \times 0.0824 = 0.0317 \quad (mg/Nm^3)$$

(14) 1 year mean value

$$C_{max}'_{(yr)} = (1/365)^{0.3} \times C_{max}'_{(24)} = 0.170 \times 0.0317 = 0.0054 \quad (mg/Nm^3)$$

Noise Prediction Points and Results

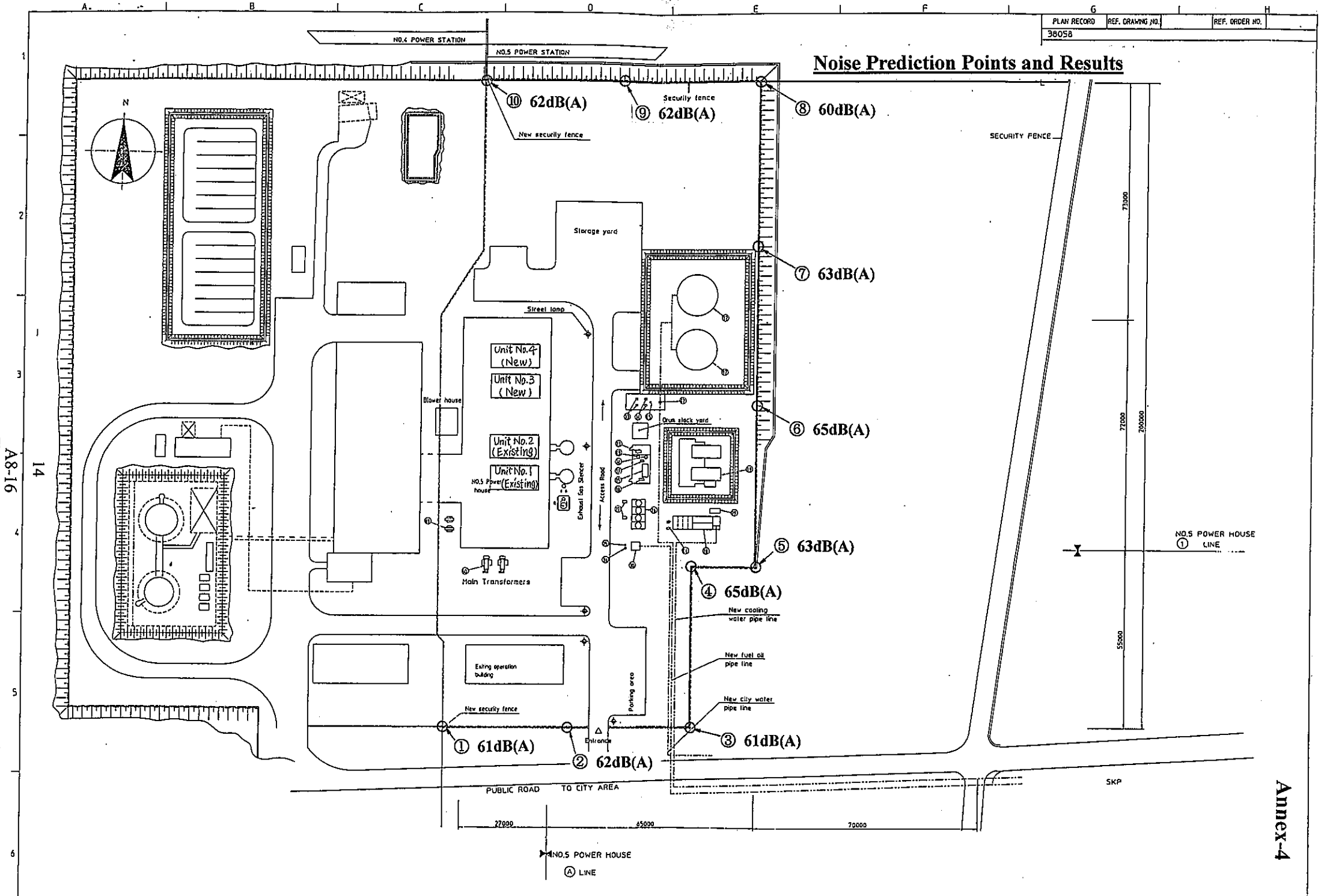

A8-16

14

6

0 1 2 3 4 5 6 7 8 9 10 11 12 13 14 15 16 17 18 19 20

Calculation of Noise Level

1. Noise level of major equipment

Based on noise level measurement of the existing diesel engine generators (units No.1 and No.2) in C5 power station and general noise level of the same kind of equipment, unit noise levels that are used for noise assessment are shown as follows;

- Diesel engine generator (Outside power house): 94 dB (A)
- Radiator: 87dB (A)

2. Noise level reduction by distance

Noise level at a distant point is lower than the noise level of the source because power density of the noise will be reduced as it travels. Noise level reduction by distance is calculated as the following formula;

$$\Delta L = L_1 - L_2 = 20 \log (r_1/r_2) \quad (2.1)$$

If L_1 , r_1 and r_2 are known, L_2 (noise level at a prediction point) is calculated as the following formula;

$$L_2 = L_1 - \Delta L$$

where

ΔL : Noise level reduction by distance

L_1 : Noise level at r_1 distance from source (Usually, $r_1=1\text{m}$ is used for noise prediction)

L_2 : Noise level at r_2 distance from source (Noise level at prediction point)

3. Combination of noise level

Noise levels are combined as the following formula;

$$L_p = 10 \log (10^{L_1/10} + 10^{L_2/10} + 10^{L_3/10} \cdot \cdot \cdot + 10^{L_x/10}) \quad (3.1)$$

where

L_p : Combined noise level

L_i : Noise level of each equipment ($i=1,2,3 \cdot \cdot \cdot x$)

4. Noise level prediction

[Step 1]

Noise level at prediction point that travels from each source (diesel engine generator and radiator) is calculated by using (2.1) formula based on the distance from the source to the prediction point.

[Step 2]

Noise levels at prediction point generated from each source are combined by using (3.1) formula. Combined noise level is an overall noise level that will be measured at prediction point.

資料－9 基本設計図

1-6V

200

192

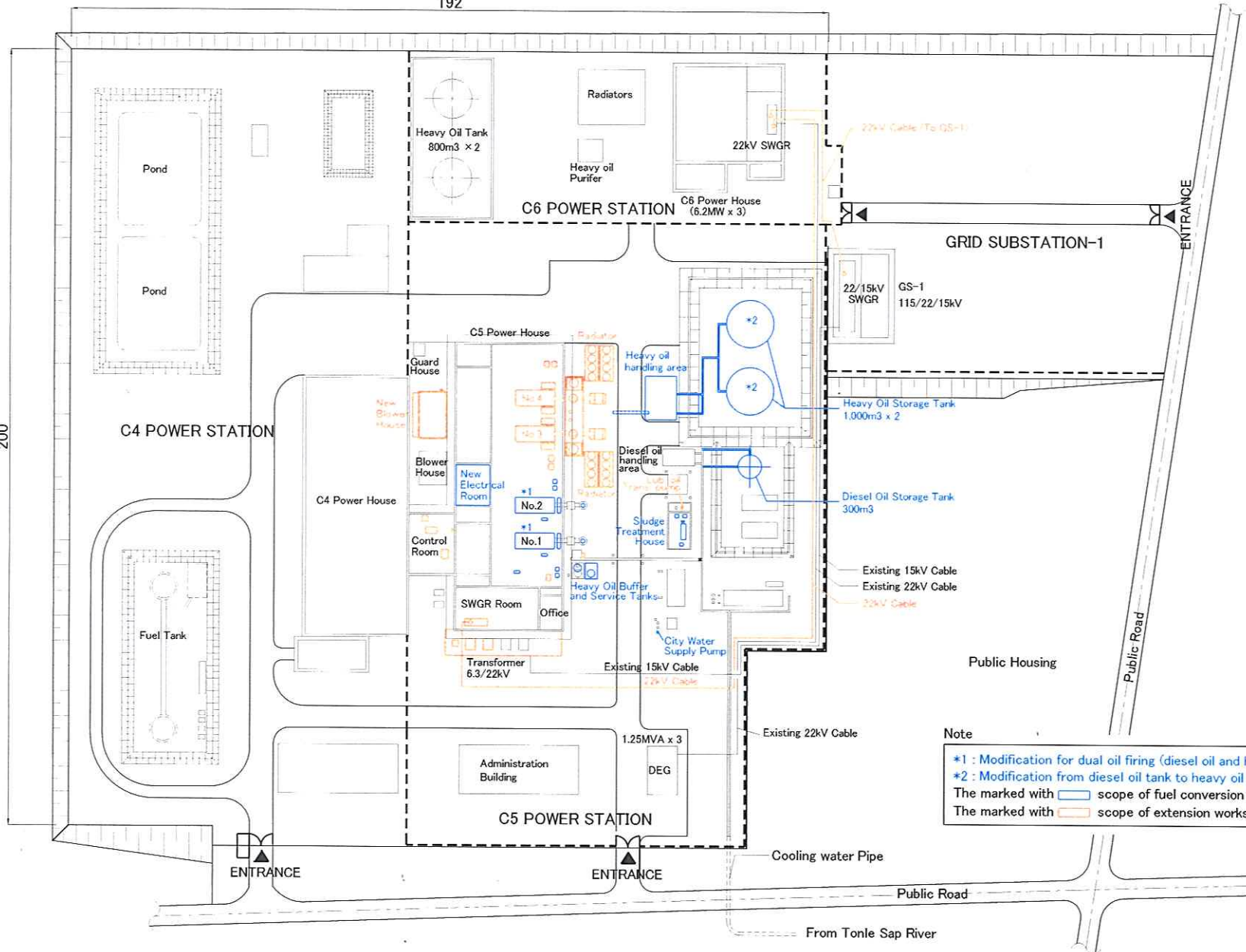

Note

- *1 : Modification for dual oil firing (diesel oil and heavy oil)
- *2 : Modification from diesel oil tank to heavy oil tank

The marked with scope of fuel conversion works

The marked with scope of extension works

SCALE 0 10 50 100m

全体配置図

G-01 : SITE PLAN

A9-2

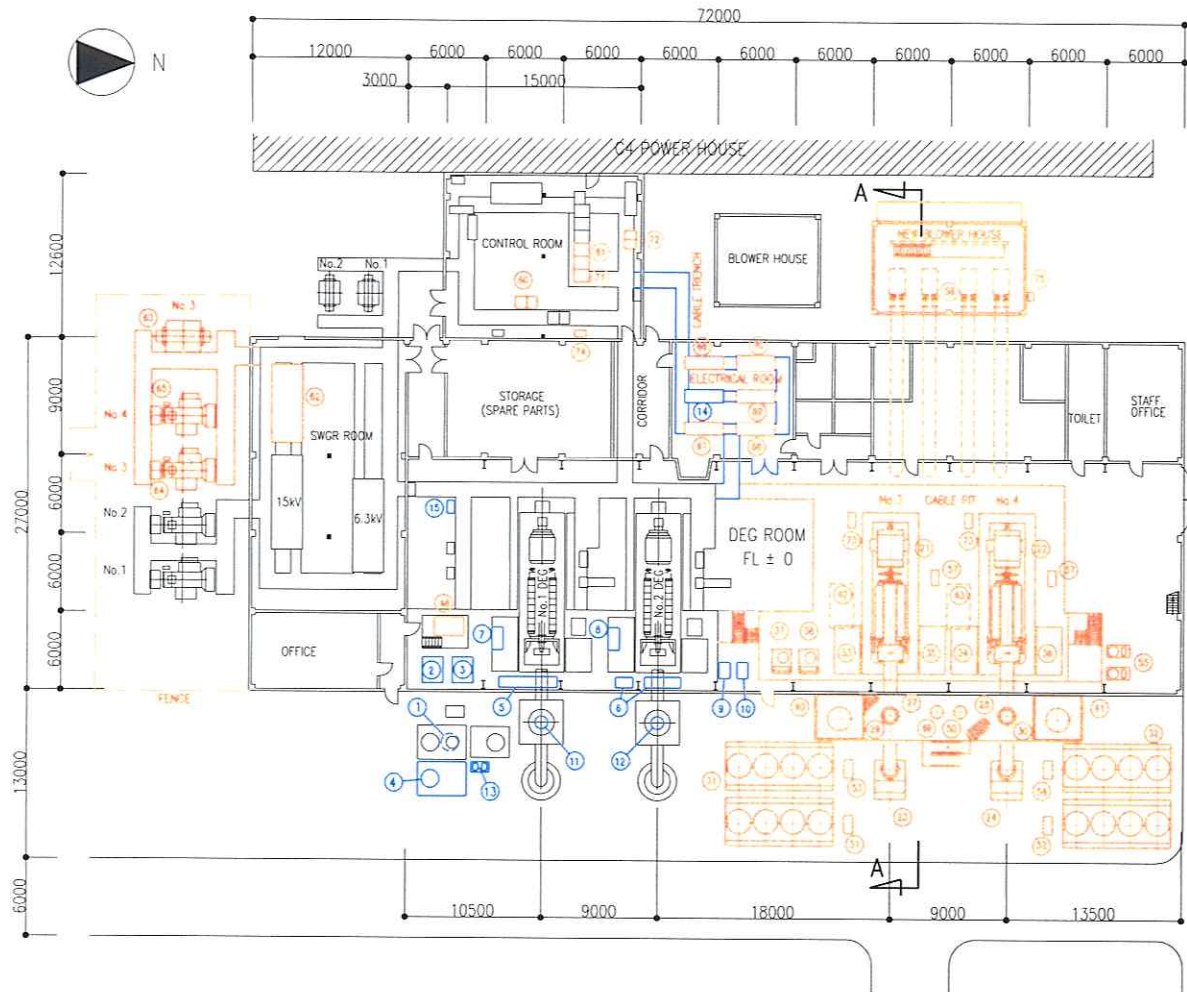

Note

- 1. The marked with scope of fuel conversion works (existing No.1 and No.2 DEG units).
- 2. The marked with scope of expansion works (new No.3 and No.4 DEG units).

No.	Equipment Name	No.	Equipment Name
1	No 1 Heavy oil buffer tank	45	No 2 Heavy oil service tank
2	No 1 Heavy oil purifier unit	41	No 2 Diesel oil service tank
3	No 2 Heavy oil purifier unit	42	No 3 Lub oil sump tank unit
4	No 2 Heavy oil service tank	43	No 4 Lub oil sump tank unit
5	No 1 Fuel oil supply equipment	44	No 3 Turbo charger lub. oil unit
6	No 2 Fuel oil supply equipment	45	No 4 Turbo charger lub. oil unit
7	No 1 Diesel engine lub. oil cooler	46	No 3 Fuel oil drain tank with pump unit
8	No 2 Diesel engine lub. oil cooler	47	No 3 Sludge tank with pump unit
9	No 1 Turbo charger lub. oil unit	48	Sludge collecting tank
10	No 2 Turbo charger lub. oil unit	49	High temperature water expansion tank
11	No 1 Exhaust gas stack	50	Low temperature water expansion tank
12	No 2 Exhaust gas stack	51	No 3 High temperature water circulation pump
13	Feed water pump (No 1 and 2)	52	No 4 Low temperature water circulation pump
14	Station common panel	53	No 3 High temperature water circulation pump
15	Fuel conversion panel	54	No 4 High temperature water circulation pump
16	No 3 Diesel engine generator	55	Air compressor unit (No 3 and 4)
17	No 4 Diesel engine generator	56	Blower and duct
18	No 3 Air intake house	57	Engine Load Panel
19	No 4 Air intake house	58	
20	No 3 Exhaust gas silencer	59	Remote control panel for 22kV SWGR
21	No 4 Exhaust gas silencer	60	DEG control panel
22	No 3 Exhaust gas stack	61	22kV SWGR
23	No 4 Exhaust gas stack	62	No 3 Station transformer
24	No 3 Radiator	63	No 3 Main transformer
25	No 4 Radiator	64	No 4 Main transformer
26	No 3 Fuel oil supply aux. equipment	65	Station panel
27	No 4 Fuel oil supply aux. equipment	66	No 3 DEG Unit MCC
28	No 3 Lub oil supply equipment	67	No 4 DEG Unit MCC
29	No 4 Lub oil supply equipment	68	Unit common panel
30	No 3 Heavy oil purifier unit	69	Battery and charger
31	No 4 Heavy oil purifier unit	70	Common Supervisory panel
32	No 2 Heavy oil buffer tank	71	Governor Panel
		72	6.3kV Panel
		73	Fire alarm panel
		74	Blower Panel

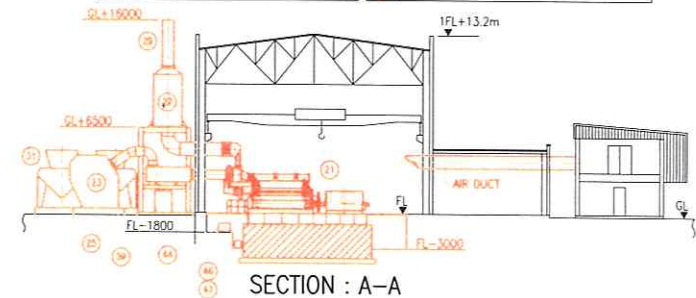

G-02 : LAYOUT OF GENERATING FACILITIES
発電設備配置図

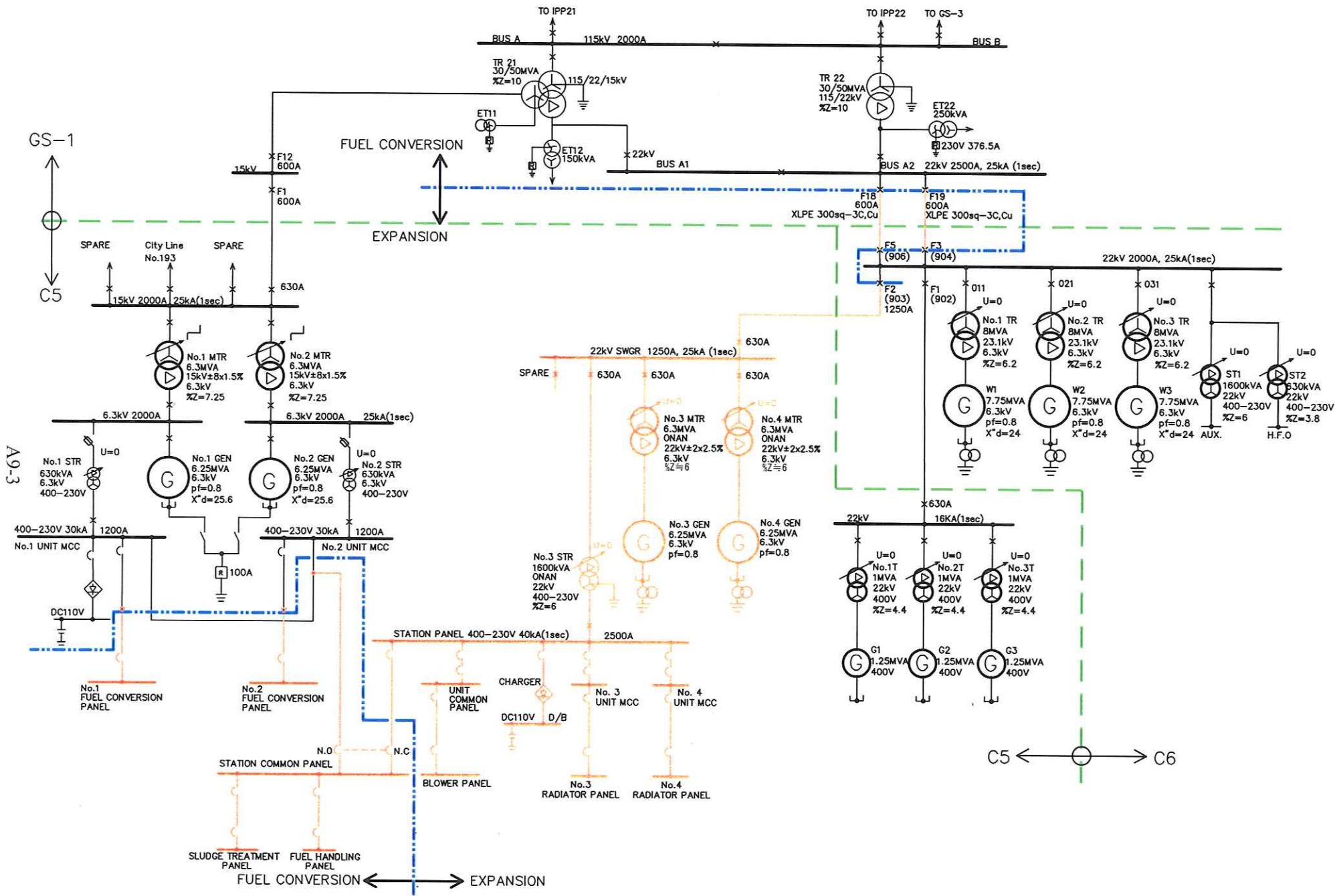

E-01: KEY SINGLE LINE DIAGRAM
全体単線図

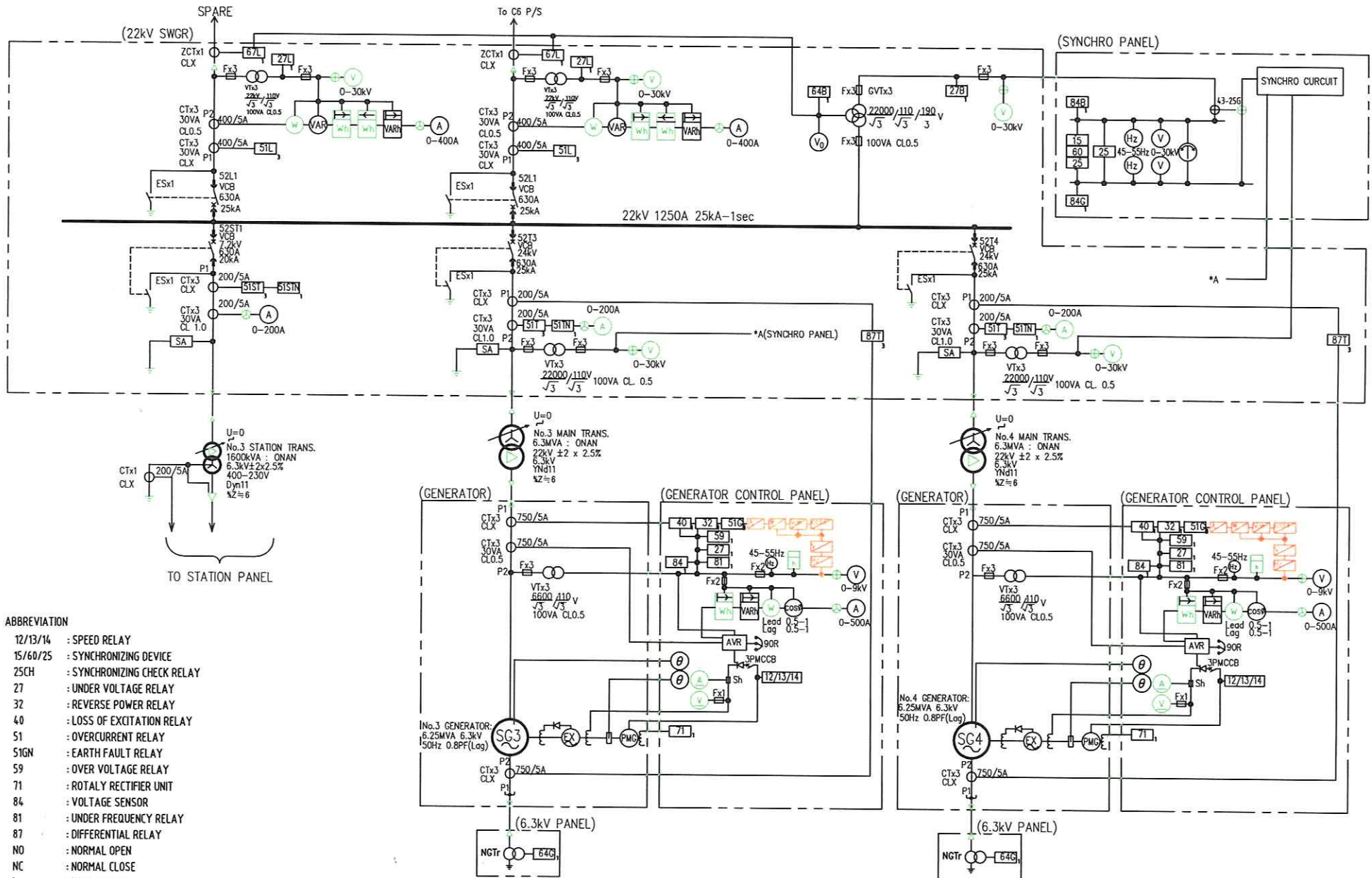

A9-5

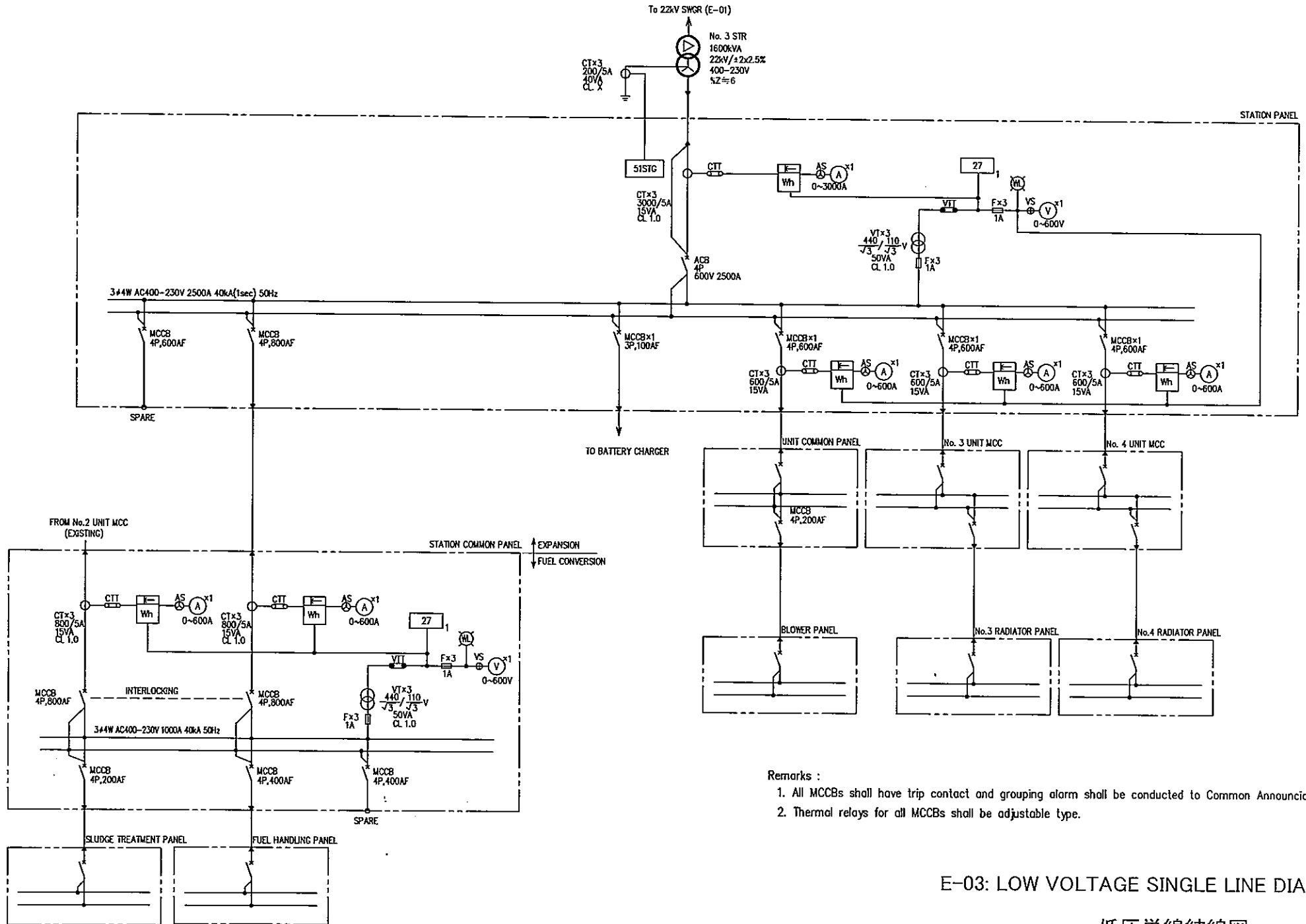







- Remarks :
1. All MCBs shall have trip contact and grouping alarm shall be conducted to Common Annunciator Panel.
 2. Thermal relays for all MCBs shall be adjustable type.









E-03: LOW VOLTAGE SINGLE LINE DIAGRAM

低圧単線結線図













1. PIPINGS

SYMBOL	DESCRIPTIONS
	PIPING LINE
	EXISTING PIPING LINE
	HEAT INSULATED PIPING LINE
	ELECTRICAL HEAT TRACE WITH INSULATION PIPING LINE
	CONNECTED PIPE
	NON-CONNECTED PIPE
	AND SCOPE OF SUPPLY UNDER THE PROJECT

2. ACCESSORIES

SYMBOL	DESCRIPTIONS
	PUMP
	DUPLEX FILTER
	SINGLE FILTER
	Y-TYPE STRAINER
	EXPANTION JOINT
	FLEXIBLE TUBE
	ELECTRIC HEATER WITH THERMO SWITCH
	FLOW METER

3. VALVES

SYMBOL	DESCRIPTIONS
	GLOBE VALVE
	CLOSED VALVE AT NORMAL OPERATION
	BUTTERFLY VALVE
	CHECK VALVE
	SCREW-DOWN CHECK VALVE
	THREE WAY VALVE
	PRESSURE REGULATING VALVE
	PRESSURE REDUCING VALVE
	MOTOR VALVE
	SOLENOID VALVE
	SAFETY VALVE
	FLOAT VALVE

A9-7

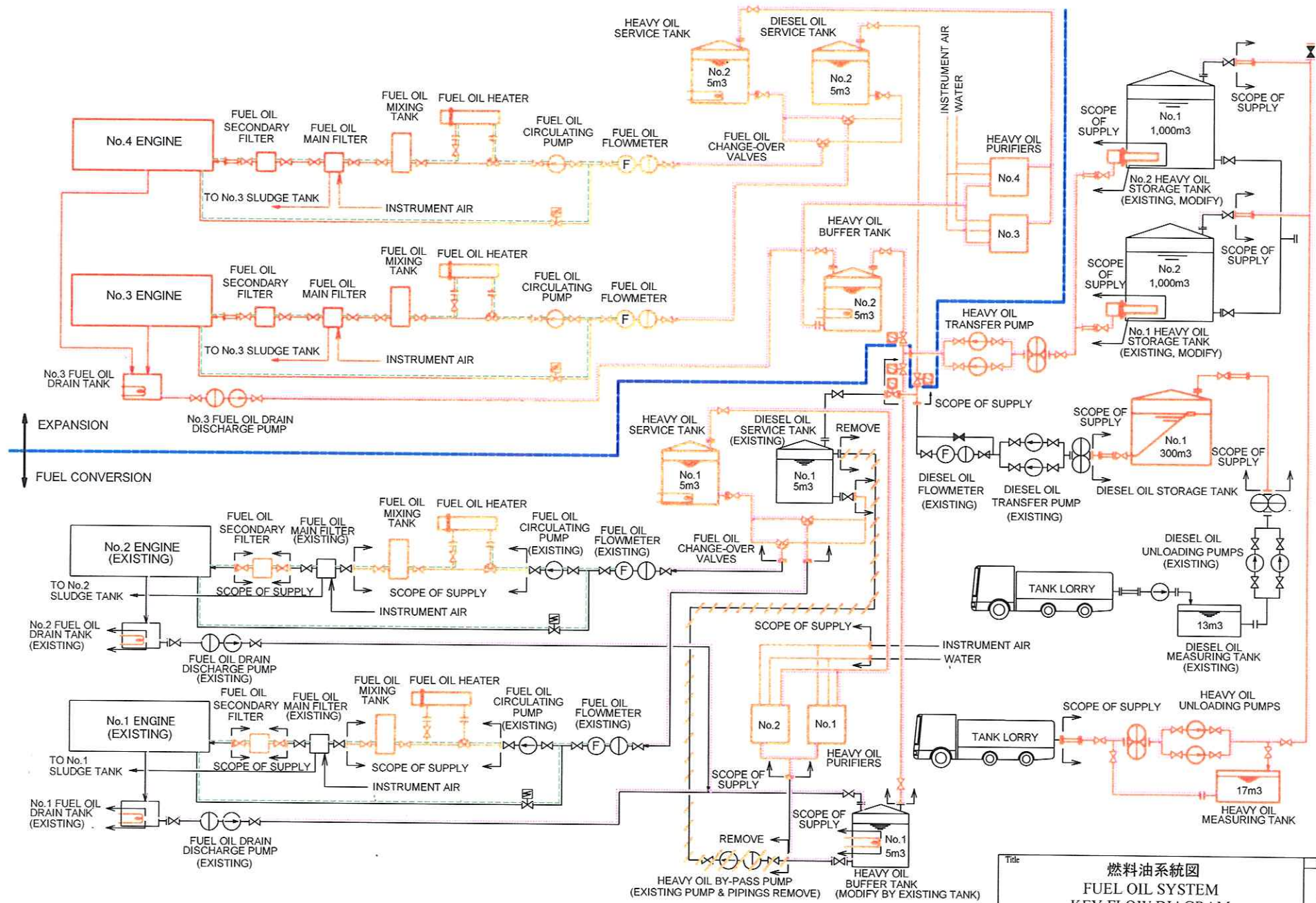

Title	燃料油系統圖 FUEL OIL SYSTEM KEY FLOW DIAGRAM	DWG. No.	M-02
-------	---	----------	------

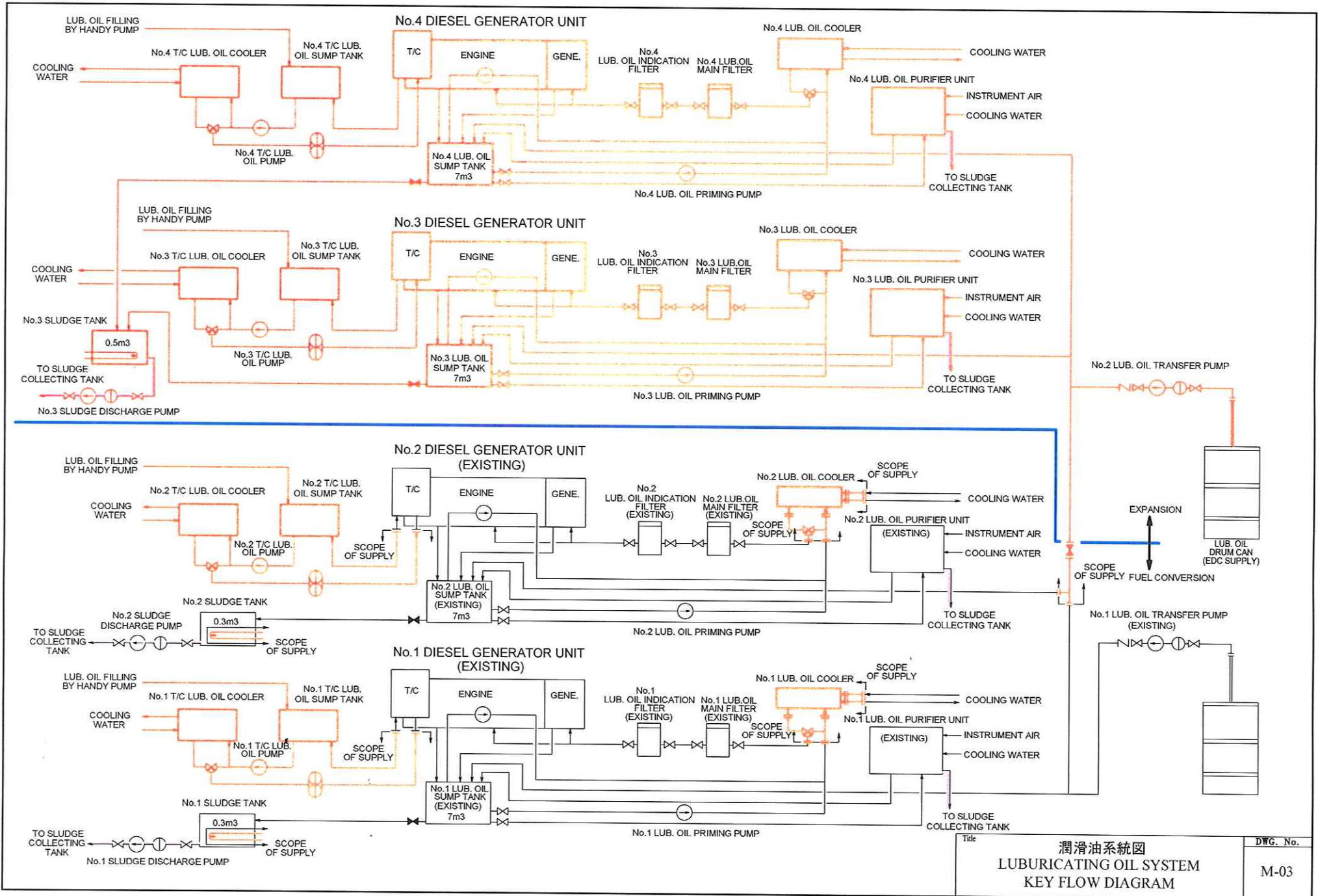

Title	潤滑油系統圖 LUBRICATING OIL SYSTEM KEY FLOW DIAGRAM	DWG. No.	M-03
-------	--	----------	------

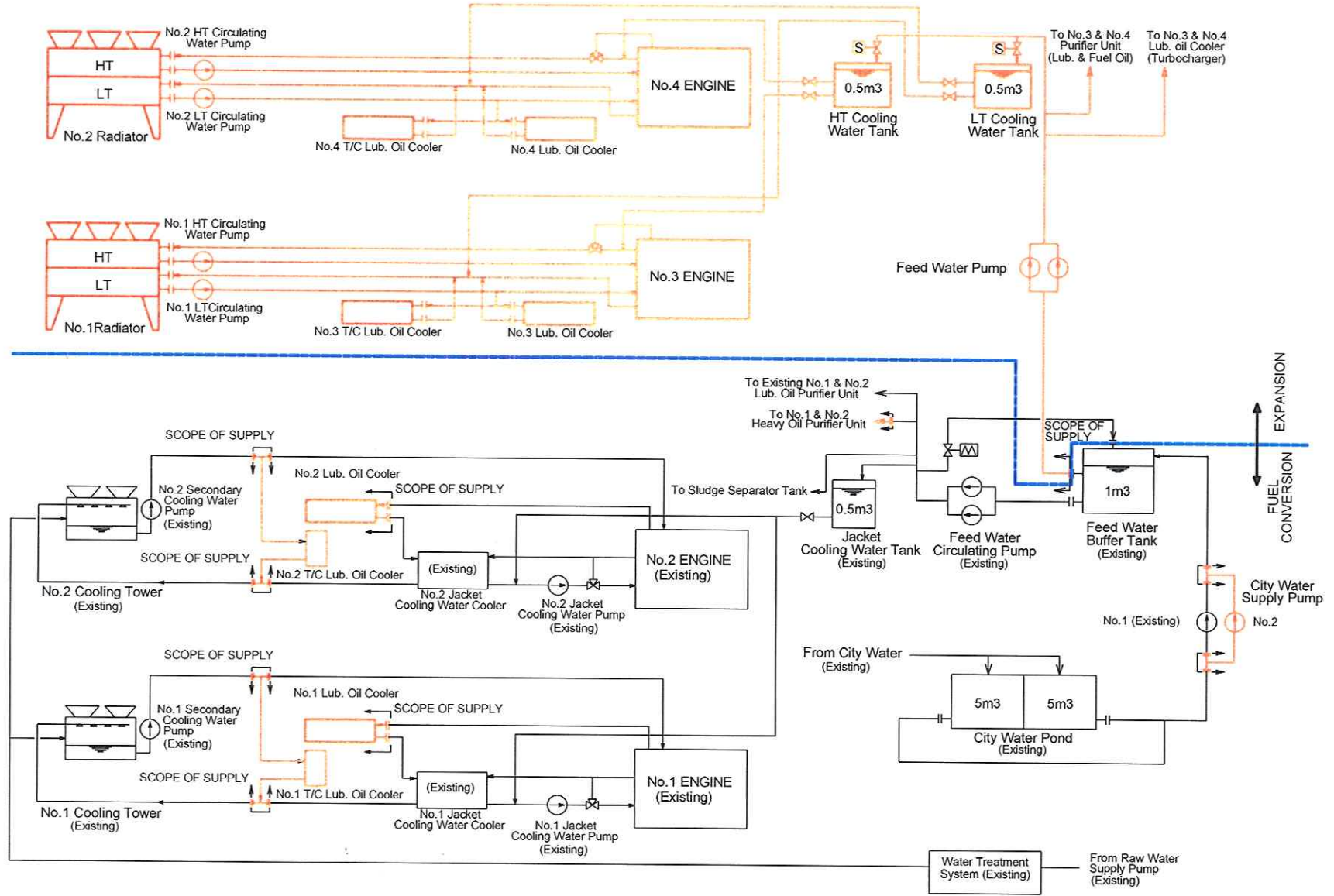

Title	冷却水系統圖 COOLING WATER SYSTEM KEY FLOW DIAGRAM	DWG. No.	M-04
-------	--	----------	------

A9-10

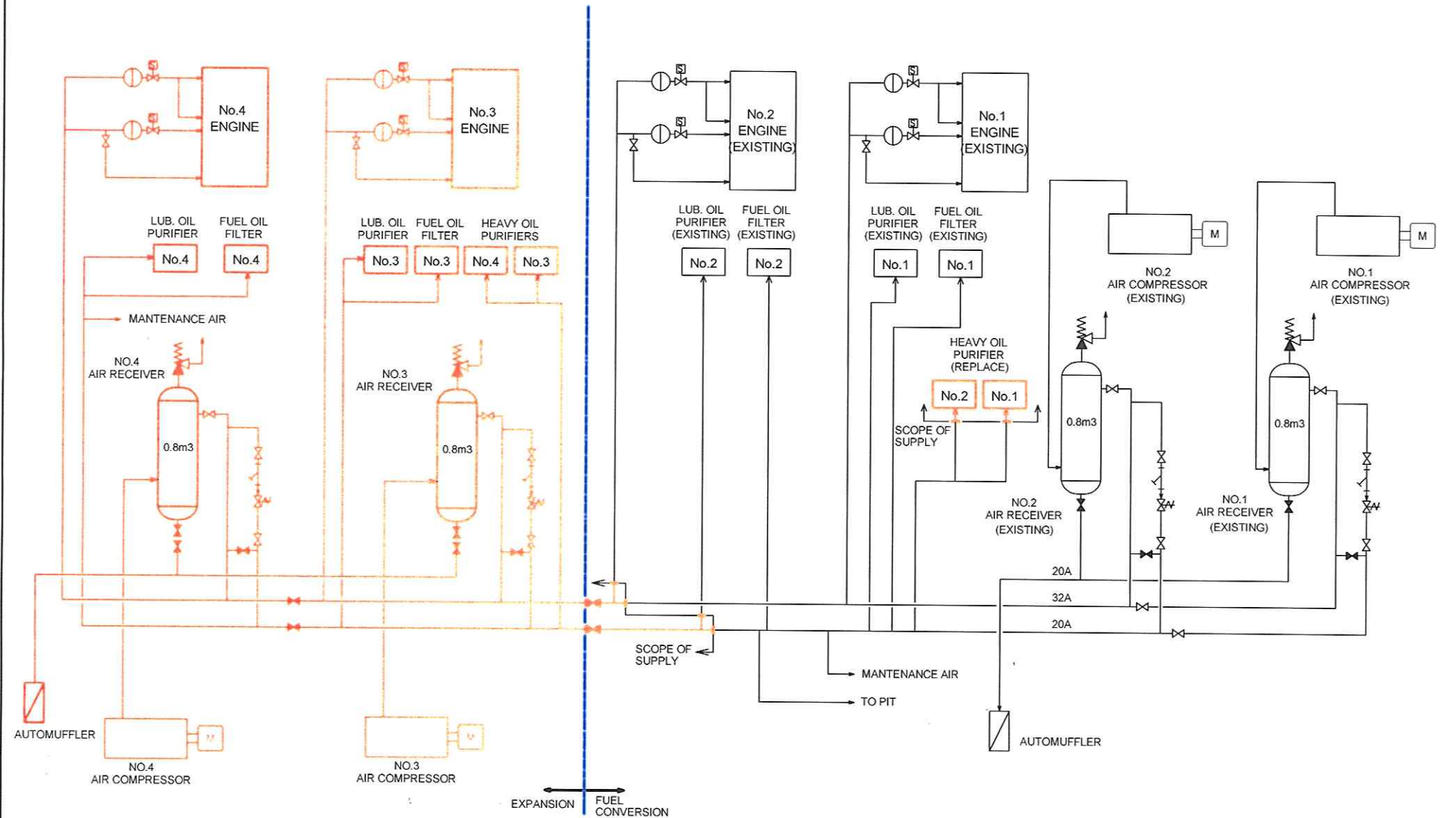

Title	壓縮空氣系統圖 COMPRESSED AIR SYSTEM KEY FLOW DIAGRAM	DWG. No.
		M-05

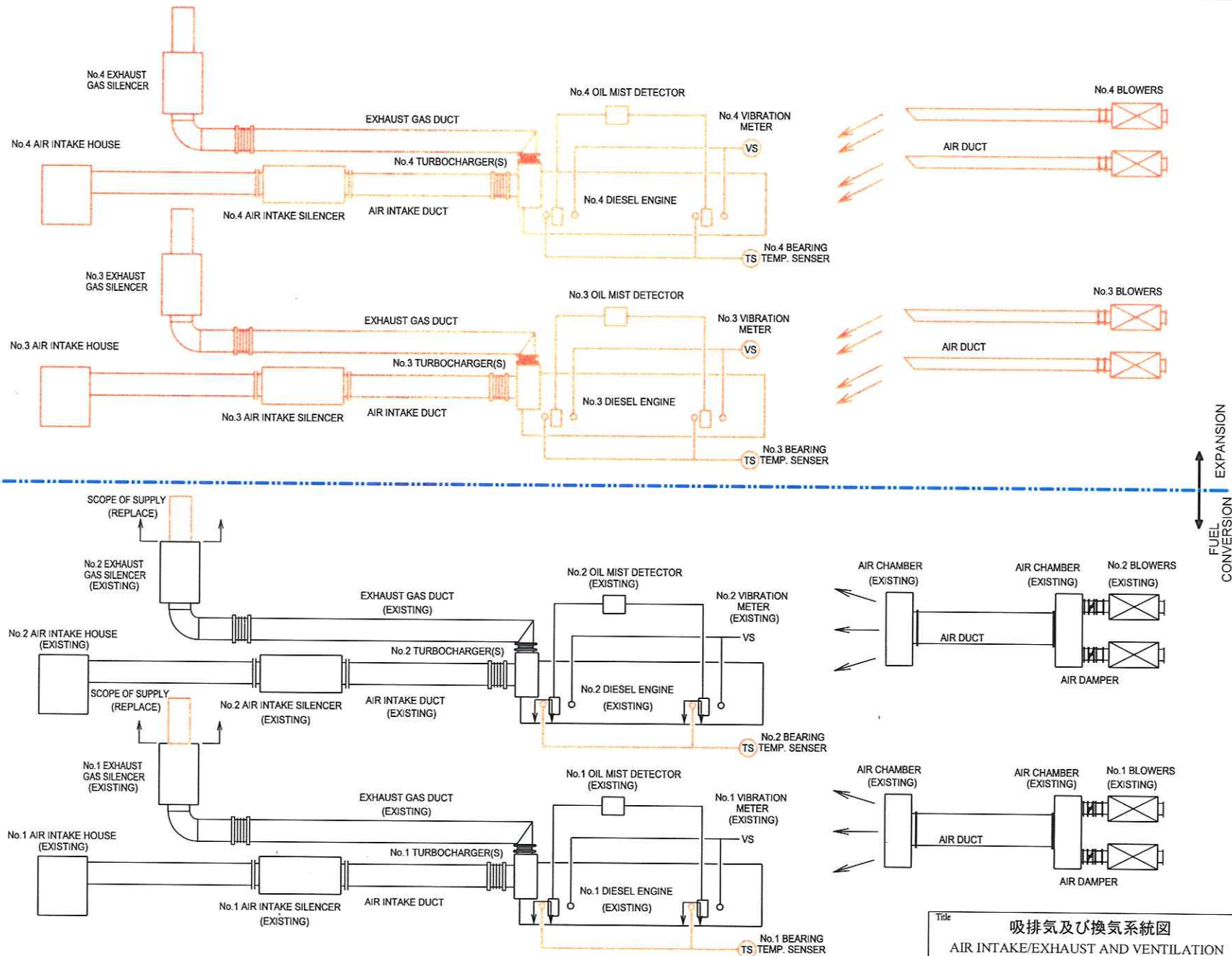

Title 吸排気及び換気系統図
AIR INTAKE/EXHAUST AND VENTILATION
SYSTEM KEY FLOW DIAGRAM

DWG. No.
M-06

EXPANSION ← → FUEL CONVERSION

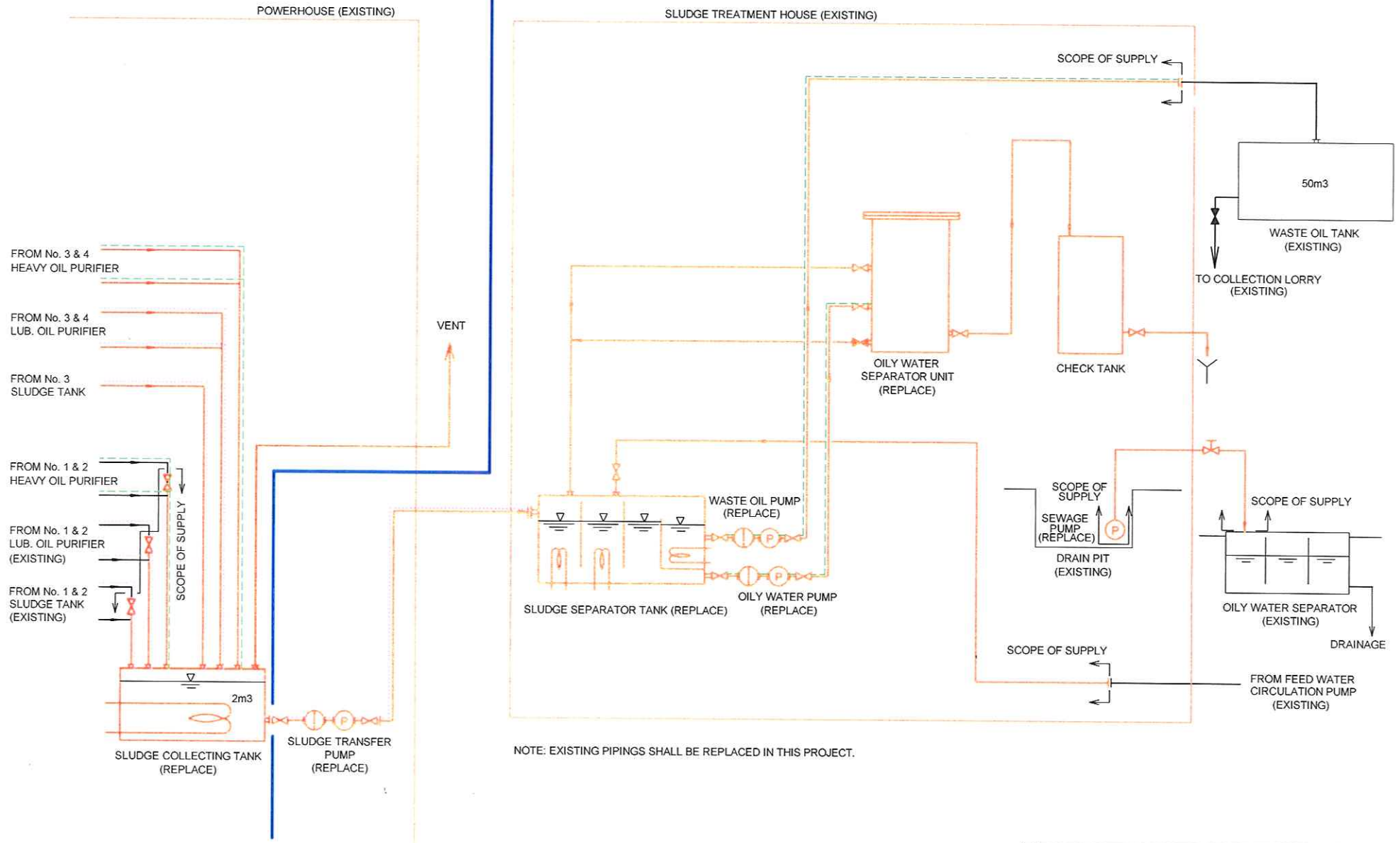

NOTE: EXISTING PIPINGS SHALL BE REPLACED IN THIS PROJECT.

Title	廃油系統図 SLUDGE SYSTEM KEY FLOW DIAGRAM	DWG. No. M-07
-------	--	------------------

資料－10 当該国の社会経済状況

主要指標一覽

	指標項目	1989年	1999年	2000年	2001年	2001年の 地域平均値
社会 指 標 等	国土面積 (1000km ²)	177	177	177	177	n. a.
	人口 (百万人)	8.9	11.8	12.0	12.3	1,822.5
	人口増加率 (%)	3.2	2.2	2.0	1.8	0.9
	出生時平均余命 (歳)	n. a.	54	54	54	69
	妊産婦死亡率 (/ 10万人)	n. a.	n. a.	n. a.	470(90-98)	n. a.
	乳児死亡率 (/ 1000人)	n. a.	n. a.	95.0	97.0	33.7
	一人当たりカロリー摂取量 (kcal/1	1,780	1,940	2,011	1,967	2,701
	初等教育総就学率(男)(%)	n. a.	109.5	116.8	n. a.	n. a.
	(女)(%)	n. a.	95.2	103.3	n. a.	n. a.
	中等教育総就学率(男)(%)	n. a.	22.2	23.7	n. a.	n. a.
	(女)(%)	n. a.	12.2	13.5	n. a.	n. a.
	高等教育総就学率(%)	n. a.	2.7	2.8	n. a.	n. a.
	成人非識字率 (15歳以上の人口の内 :	38.6	32.7	32.0	31.3	13.2
	絶対的貧困水準 (1日1\$以下の人口比	n. a.	n. a.	n. a.	n. a.	n. a.
失業率(%)	n. a.	n. a.	n. a.	n. a.	n. a.	
経 済 指 標	GDP (百万USドル)	1,075	3,012	3,367	3,404	1,664,945
	一人当たりGNI (USドル)	140	260	270	270	900
	実質GDP成長率(%)	3.5	5.0	7.7	6.3	5.5
	産業構造 (対GDP比 : %)					
	農業	52.3	39.6	38.2	36.9	14.6
	工業	15.4	18.8	20.8	21.9	48.5
	サービス業	32.3	41.6	41.0	41.2	36.2
	産業別成長率(%)					
	農業	7.1	1.1	-0.3	3.9	1.5
	工業	1.6	7.5	34.6	15.5	6.9
	サービス業	-1.1	8.1	2.1	2.5	6.2
	消費者物価上昇率 (インフレ : %)	n. a.	4.0	-0.8	-0.6	n. a.
	財政収支 (対GDP比 : %)	n. a.	n. a.	n. a.	n. a.	n. a.
	輸出成長率 (金額 : %)	n. a.	19.1	36.5	14.6	3.6
	輸入成長率 (金額 : %)	n. a.	22.6	17.5	12.6	4.0
	経常収支 (対GDP比 : %)	n. a.	-5.1	-3.1	-3.1	n. a.
	外国直接投資純流入額 (百万ドル)	0	144	112	113	48,913
	総資本形成率 (対GDP比 : %)	11.0	15.8	13.5	17.9	31.0
	貯蓄率 (対GDP比 : %)	3.4	3.9	4.3	9.8	35.8
	対外債務残高 (対GNI比 : %)	1.1	1.1	0.9	0.6	4.7
DSR (対外債務返済比率 : %)	n. a.	2.9	2.0	1.3	12.1	
外貨準備高 (対輸入月比 : %)	n. a.	3.2	3.1	3.5	7.5	
名目対ドル為替レート*2 (通貨単位 : リエル Riel)	n. a.	3,807.8	3,840.8	3,916.3	n. a.	
政*	政治体制 : 立憲君主制					
治	憲法 : 1993年9月24日公布。99年3月改正					
指	元首 : 国王。ノロドム・シヌーク (Norodom SIHANOUK) 。1993年9月24日即位					
標	議会 : 2院制。定数は上院61、下院122。ともに直接選挙制。任期は上院6年、下院5年 (上院は1999年3月の設置時に限り指名制。任期5年)					

出典 World Development Indicators CD-ROM 2003 WB

*1 FAO Food Balance Sheets 2003年 6月 FAO Homepage

*2 International Financial Statistics Yearbook 2002 IMF

*3 世界年鑑 2003 共同通信社

注 ● () に示されている数値は調査年を示す。(90-98)と示されている場合は1990年度から98年度までの間の最新値を示す

● 「人口」、「GDP」及び「外国直接投資純流入額」の「2001年の地域平均値」においては、地域の総数を示す

● 地域は東アジア・大洋州。ただし「一人当たりカロリー摂取量」における地域はアジア広域

● 就学率が100を超えているのは、学齢人口推計値と実際の就学データの間になずれがあるため

資料-11 ボーリング・平板載荷試験結果

Japanese Grand Aid

Kingdom of Cambodia

Nation - Religion - King

**THE PROJECT FOR CONSTRUCTION AND IMPROVEMENT OF
THE DIESEL ENGINE GENERATORS OF THE EDC C5 POWER
PLANT**

Soil Investigation Report

Prepared for:

**CAMBODIA ELECTRICITY AUTHORITY AND YACHIYO
ENGINEERING CO.,LTD.**

April 2004

ANGKOR WAT ENGINEERING & CONSTRUCTION CO.,LTD.

SOIL TESTING AND GEORESEARCH INC

Project:

**THE PROJECT FOR CONSTRUCTION AND IMPROVEMENT OF
THE DIESEL ENGINE GENERATORS OF THE EDC C5 POWER
PLANT**

Checked by



SEA Sochivoan, P.Eng
Geotechnical Engineer

Prepared by



CHEA Sereyvuth
Geotechnical Manager

April 2004

CONTENTS

I.	General	1
1.	Introduction	1
2.	Geology and Landform	1
II.	Geo-technical Investigation	2
1.	Objective and Scope	2
2.	Site methodology	2
3.	Laboratory test	4
III.	Findings	4
1.	Subsoil condition	4
2.	Underground water condition	5
IV.	Conclusion	5
V.	Appendix-A	6
	Figure 1. Location Map	7
	Figure 2. Geology Map	8
	Chart 1. Plasticity Chart for Cohesive Soil Strata	9
	Table 1. The results of Laboratory test	10
	Figure 3. Grain size distribution	11
	Figure 4. Unconfined compressive strength	14
	Figure 5. Consolidation Test Sheet	18
	Figure 6. Shear Box Test Sheet	20
	Figure 7. Borehole Log and Stratigraphy	25
	Figure 8. Photographs	26
VI.	Appendix-B (Plate Test)	29
VII.	Appendix-C (Concrete Coring and Compression Test)	34

I. General

1. Introduction

Soil investigation is a requirement for feasibility and detail engineering design of structures. It is to determine subsoil conditions beneath the project site and physical and geo-technical characteristics of the underlying soil strata. These provide economical cost and safety of construction structure.

2. Geology and Landform

The geology of the project area and its immediate environment are shown in Figure 1.

Cambodia is geologically composed of three different structures, they are mostly Triassic, Jurassic-Cretaceous and Quaternary. The Triassic period covers a large area in the east, Jurassic-Cretaceous Era forming important highlands in the west and, between them, the Quaternary basin occupies the whole central plain of the country.

The area of the site is situated within a belt of recent lacustrine sediments. The soil deposit is overlying alluvial of the Holocene period. In site area, they are reported to comprise gray silts, sands, clay and organic soils. The map also shows the alluvial of Phnom Penh, where it flows from vicinity high land and upper Mekong River to fulfill swamp and flat land, as a deposit of recent origin.

II. Geo-technical Investigation

Angkor Wat Engineering and Construction Company was commissioned to undertake geo-technical investigation for this particular project for the determination of soil condition, its relative density, consistency, classification and characteristics of soil types, especially geologic and geo-technical condition of the soil beneath the Project Site for the construction design.

1. Objective and Scope

The objective of soil investigation is contributed to analyzing various subsoil conditions including their characteristics and composition status of strata distributed beneath the project area. The scopes and the objectives of the subsurface investigation included the following tasks:

- An actual field observation and inspection.
- Soil boring and carry out the Standard Penetration Test at the proposed location site.
- Samples collection, preservation and transportation to the laboratory.
- Laboratory testing of the soil samples from split-barrel sampler of Standard Penetration Test and thin-walled sampler.
- Interpretation and evaluation of the field and Laboratory test results.
- Determination of the factual characteristics of soil and engineering properties of soil for the purpose of getting a conclusive data to support the recommendation for the construction design.

2. Site Methodology

Subsurface exploration was carried out to determine the arrangement of soil strata and engineering properties of the underlying soils, particularly strength and deformation characteristics for foundation design of the project. The field operations were carried out in accordance with ASTM Standards as summarizing below:

- Standard Penetration test (SPT) ASTM D-1586
- Field Soil classification ASTM D-2487, D-2488
- Preservation and Transportation of soil samples ASTM D-4220
- Ground Water Table Observation, ASTM D-4750
- Soil boring.

The main activities of the whole field investigations consisted of the following tasks:

- Located the borehole to the required position
- Bored out the soil and observed soil cuttings to classify the soil layers and prepare of borehole log.
- Carry out Standard Penetration Test (SPT) at 2.00m intervals
- Seal and label all disturbed and undisturbed soil samples in the core boxes and deliver to the laboratory (Protected from the exposure to the sun).
- Observed the stable ground water table.
- Collecting disturbed and undisturbed soil samples at every two meters intervals and every soil strata changes.
- The borehole depth terminated when the N-value of SPT exceeds 30 for 5m depths.

Soil boring

Boring Machine used in the project area is YIB-50M, 50 meters depth capacity and the diameter of 150 mm, equip with SPT. A spiral-drilling head was employed in this operation. The process was risen up and continued boring every 2.00meter depth. The field soil classification and observation such as soil name, consistency, color, soil strata, percent of soil grain size estimation, ground water table, seal and label, protection from sun shine, making note and putting in core boxes were undertaken. All disturbed and undisturbed samples were transported to laboratory.

Standard Penetration Test

After the borehole has advanced to required depth, the spiral-boring rod was withdrawn and replaced with thin-wall sampler (70mm) first and than split barrel. The correct depth after cleaning out was also checked in case of borehole has collapsed and must be cleaned up again.

The Standard Penetration Test (SPT) uses 63.50 Kg drive weight at free fall height of 760 mm to drive standard split barrel and the number of blows for every 150 mm penetration was noted. The first 150mm is the setting blow and the total number of blows for the last 300mm is the N-value. The samples extracted by the split spoon sampler (ASTM-D1586) during the penetration test were tested for their engineering properties. The procedure was repeated on each succeeding depth down to the bottom of the borehole. The water level in the borehole was measured 24 hours after completion of boring works.

3. Laboratory Test

The soil samples extracted to represent the different strata from machine auger borings and SPT test were subjected to laboratory soil testing for evaluation and analysis in accordance with ASTM standard methods and specifications to classify them for their engineering values.

The laboratory-testing program was divided into two following parts:

- Natural water content determination ASTM D2216
- Atterberg limit ASTM D4318
- Specific Gravity ASTM D854 and ASTM C128
- Sieve Analysis ASTM D421 and ASTM D422
- Hydrometer test ASTM D421 and ASTM D422
- Unconfined Compression ASTM D2166
- Wet Unit weight, Dry Unit weight, Void Ratio and Porosity (Calculation).
- Consolidation Test ASTM D2435.
- Soil Classification ASTM D2488 (Both field and Laboratory)

III. Findings

1. Subsoil condition

Underlying the site are uniform layers of both cohesive and non-cohesive soil mostly alluvial in character. The soil layers stretched beneath the project site are clay, silty clay and sand. In accordance to its USCS classifications are CL, CH, CS and SW.

The boring results are shown as follows:

Soil type is firm gray silty clay, from surface level to the depth of 3.25m, with N-value ranging from 2 to 3. Below the above layer, the soil is stiff brown, gray, dark gray silty clay, with N-Value of 15 blows from the depth of 3.25m down to 9.95m. The soil layer is firm dark gray silty clay, with the N-blows count of 7 from the depth of 9.95m down to 12.30m. From 12.30m down to the depth of 13.60m, the soil layer is very loose gray very clayey medium sand, with N-blows count of 2. From 13.60m to 15.00m, the soil is medium dense brown, gray coarse sand with SPT blows of 17.

2. **Underground water condition**

The ground water met during operation of boring is one of the important factors for soil investigation because the variation of ground water level, the characteristic of soil mechanic also can be changed. The underground water level is 2.00meter depth measuring 24 hours after finished boring. It is not wastewater or water current flowing underground. But its elevation is changed depend on the season, it is decreased in dry season and increased in rainy season. The underground water condition is considerably not affecting structure foundation.

IV. **Conclusion and Recommendation**

Laboratory tested results showed that the stratigraphy of subsoil layers beneath project area, are alternately varied within clay and sand. In according to the geology formation the area occurred in Quaternary Sedimentary (during Holocene period), so the soil texture is performed by recent alluvial of sand and clay strata. The upper layer from surface level was fulfilled some 10 years ago, it was considered to be stable as natural soil. Therefore the skin friction of the soil can be taken as positive skin friction. Otherwise the physical and mechanical properties of sub-ground are not suitable for shallow foundation, because of the new formation can not bear the oil tank load. The allowable bearing capacity of soil at the depth of 4meter for shallow foundation is 300KPa calculated in the next sheet by using SPT blow-count. In the other hand, the allowable or ultimate bearing capacity of soil can be chosen at any depth depending upon the decision of engineer. But the most suitable foundation is semi-profound foundation or pile at the depth of 5m or 6m to support the oil tank because this kind of foundation is very economized and not taken very long time for the construction works.

V. Appendix-A



200

A11-10

PLATE LOADING TEST
CORE SAMPLE TEST
EXISTING DEG FDN

BORING TEST

ANNEX - A

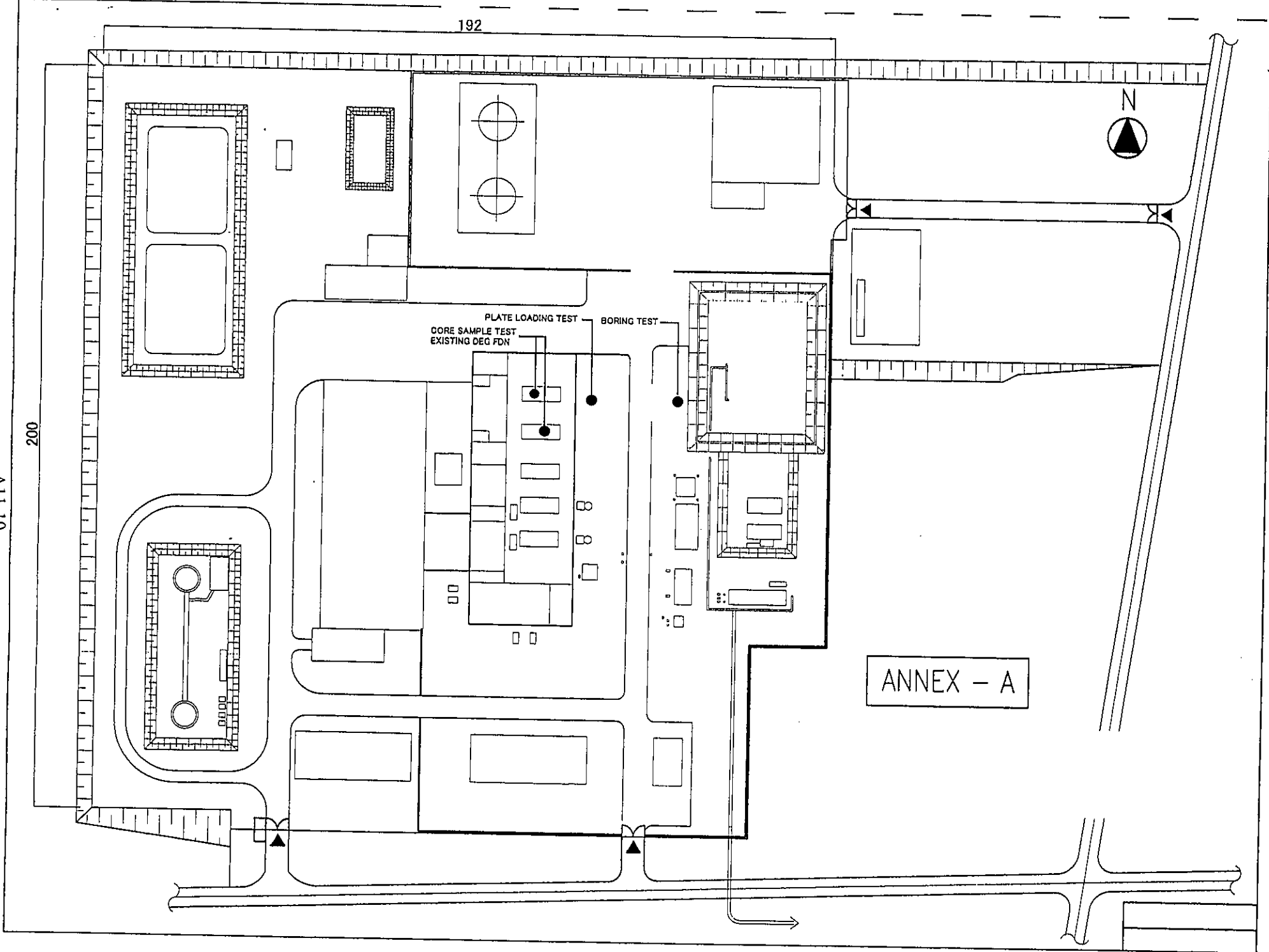
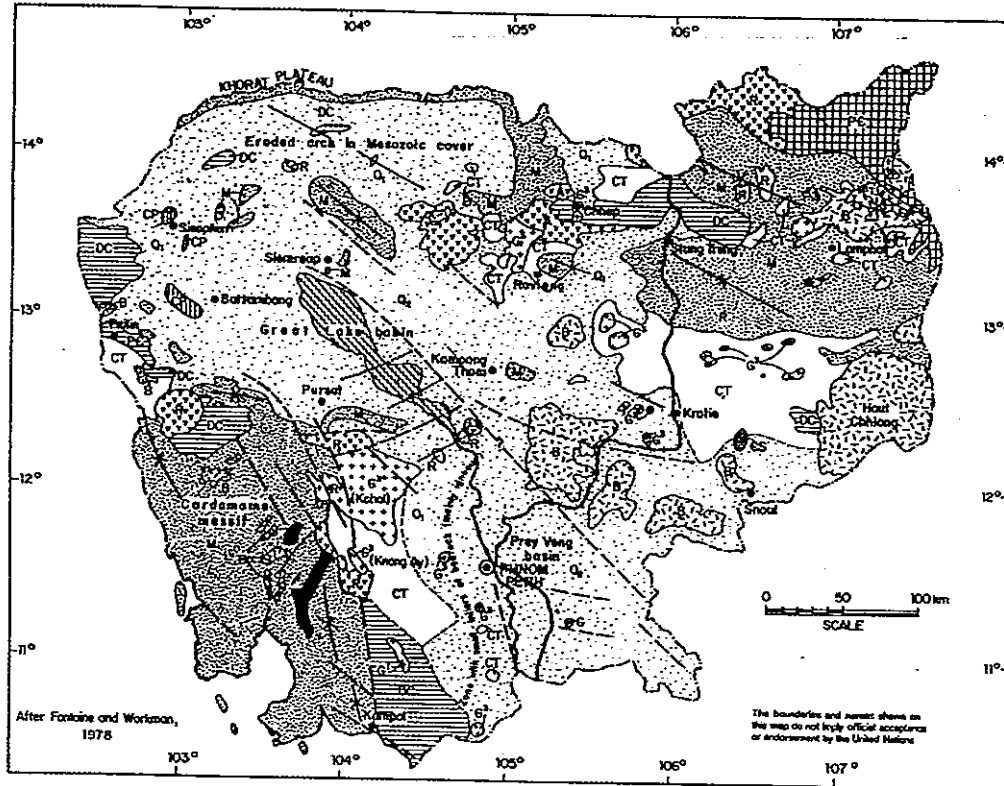

Figure 2. Geology Map of Cambodia



LEGEND

TERRANES

UNDEFORMED OR GENTLY FOLDED COVER STRATA

- Q Quaternary sedimentary rocks and unconsolidated sediments. 1: Pleistocene; 2: Holocene. Includes some small Neogene basins
- B Neogene - Quaternary platform basaltic rocks
- M Mesozoic sedimentary units (upper Triassic-Cretaceous)
- Volcano-sedimentary units (mainly Triassic, some Paleozoic). A: andesitic; R: rhyolitic.
- C-P Paleozoic sedimentary units (mainly Carboniferous-Permian).

INTRUSIVE ROCK GROUPS

- G Acid - Intermediate intrusive suites
- G₁ - Pro-Carboniferous
- G₂ - Carboniferous
- G₃ - Triassic-Jurassic
- G₄ - Cretaceous

STRUCTURE SYMBOLS

ZONES OF INDO-OSIAN FOLDING

- CT Synclinal zones in Indosian fold-belts (mainly Carboniferous-Triassic).
- DC Anticlinal zones in Indosian fold-belts (Precambrian-Silurian medium to high-grade metamorphic; Devonian-Carboniferous rocks, deformed and slightly metamorphosed).

- Regional faults, known and inferred
- Geographical lineaments
- Axes of Cenozoic epirogenic folding
- Limits of terranes, known and inferred
- Axis of swell in buried pre-Tertiary basement
- Intramontane grabens (Neogene)

EXPOSED BASEMENT ROCKS OF THE KONTUM MASSIF

- PC Precambrian-Early Paleozoic granites and high-grade metamorphic.

PLASTICITY CHART

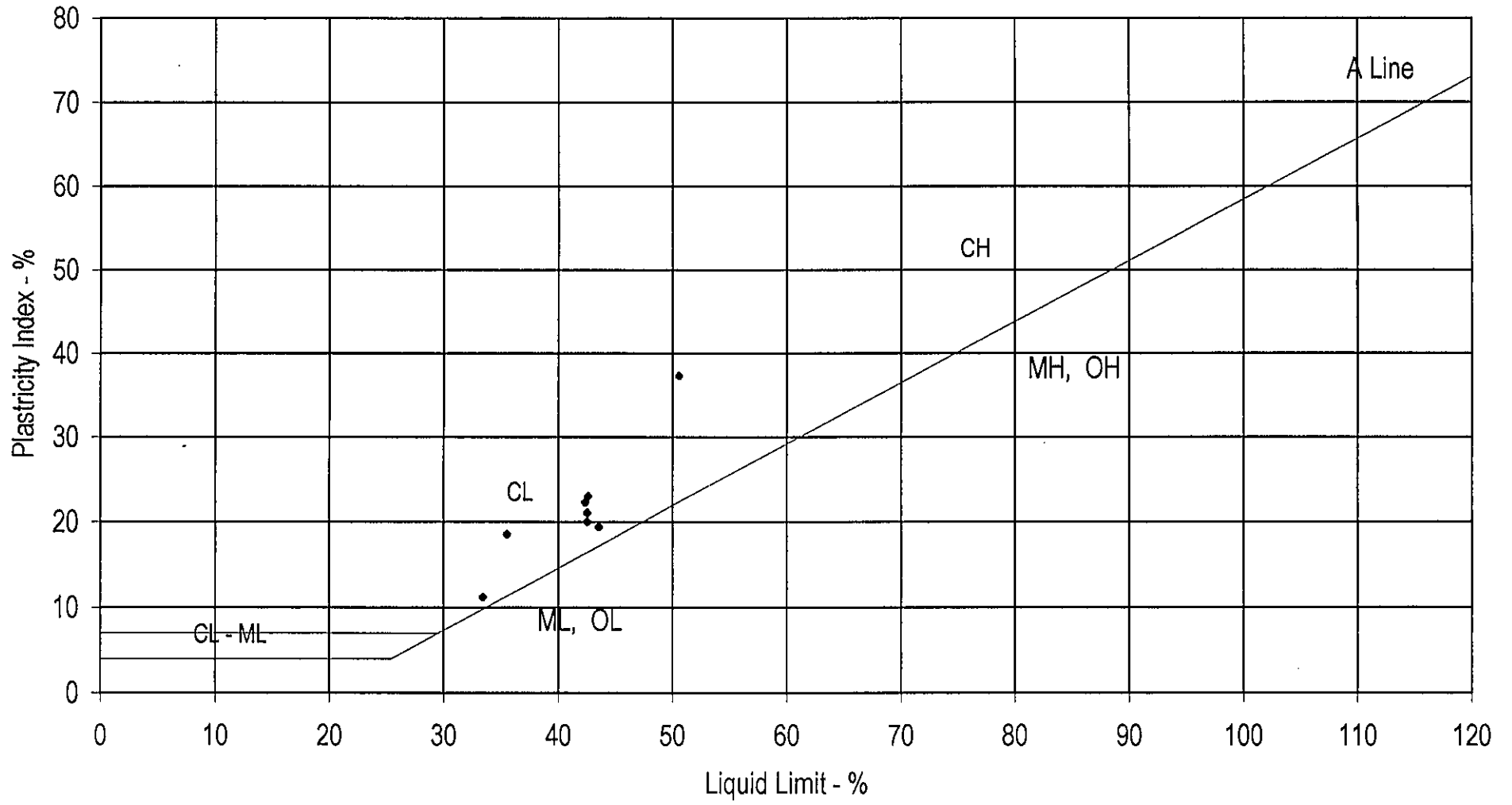

A11-12

SUMMARY OF LABORATORY TEST RESULTS

SUMMARY OF LABORATORY TEST RESULTS

Station (km)	Boring No	Sample	Depth(m)		Soil description	Unified Classification	NMC W (%)	Wet density γ_w (g/cm ³)	Specific Gravity G _s	Atterberg limit			Grain size			Consolidation			Unconf. Strength q_u (kPa)
			From	To						LL (%)	PL (%)	PI (%)	Clay and Silt %	Sand %	Gravel %	Cc/1+e ₀	Cr/1+e ₀	Cv (m ² /yr)	
PK.1	BH1	D1	1.50	1.95	Top soil (Firm gray silty clay with gobbles)														
		U1	2.00	2.80		CL	19.78	1.98	-	35.50	16.96	18.54	49.00	21.00	31.00	-	-	-	-
		D2	2.80	3.25		CH	22.84	1.91	2.71	50.50	13.21	37.29	86.50	13.00	0.50	-	-	-	168.59
		U2	4.00	4.80	Stiff brown, gray, dark gray silty clay	CL	21.20	2.01	2.69	42.50	21.50	21.00	86.50	12.50	1.00	-	-	1.43x10 ⁻⁷	-
		D3	4.80	5.25		-	-	2.06	-	-	-	-	-	-	-	-	-	-	377.99
		U3	6.80	7.60		CL	21.52	2.03	-	42.60	19.67	22.93	86.50	8.50	5.00	-	-	1.4x10 ⁻⁷	-
		D4	7.60	8.05		CL	22.79	2.04	-	42.30	20.08	22.22	90.50	9.00	0.50	-	-	-	287.16
		U4	9.55	10.35	Firm dark gray silty clay	CL	30.79	1.96	2.70	42.50	22.53	19.97	98.50	1.00	0.50	-	-	-	-
		D5	10.35	10.80		CL	34.02	2.02	-	43.50	24.15	19.35	97.00	2.50	0.50	-	-	-	98.64
		U5	12.30	13.10	Very loose gray very clayey medium sand	SC	21.23	1.92	2.66	33.40	21.94	11.46	26.00	65.00	9.00	-	-	-	-
		D6	13.10	13.55	Very loose gray very clayey well-graded medium sand	SW	22.34	2.01	2.65	-	-	-	26.00	73.50	0.50	-	-	-	-
		D7	14.55	15.00	Medium dense brown, gray medium to coarse sand	SW	23.38	2.03	2.65	-	-	-	38.00	57.00	5.00	-	-	-	-

A11-13

Grain size analysis and distribution curve

BH1/D2		BH1/U2		BH1/U3		BH1/D4	
d	% finer	d	% finer	d	% finer	d	% finer
75.0		75.0		75.0		75.0	
37.5		37.5		37.5		37.5	
19.0		19.0		19.0		19.0	
16.0		16.0		16.0	100.00	16.0	
8.0		8.0	100.00	8.0	96.47	8.0	
4.8	100.00	4.8	99.90	4.8	95.53	4.8	
2.0	99.65	2.0	98.92	2.0	95.12	2.0	100.00
1.0	98.91	1.0	97.69	1.0	94.39	1.0	99.89
0.425	96.89	0.425	95.45	0.425	93.14	0.425	99.76
0.250	94.65	0.250	93.07	0.250	91.87	0.250	99.63
0.125	91.18	0.125	90.17	0.125	90.02	0.125	99.10
0.075	88.71	0.075	88.03	0.075	88.68	0.075	93.49
0.030		0.030		0.030		0.030	
0.0217		0.0217		0.0217		0.0217	
0.0154		0.0154		0.0154		0.0154	
0.0114		0.0114		0.0114		0.0114	
0.0081		0.0081		0.0081		0.0081	
0.0058		0.0058		0.0058		0.0058	
0.0041		0.0041		0.0041		0.0041	
0.0034		0.0034		0.0034		0.0034	
0.0021		0.0021		0.0021		0.0021	
0.0013		0.0013		0.0013		0.0013	

GRAIN SIZE DISTRIBUTION

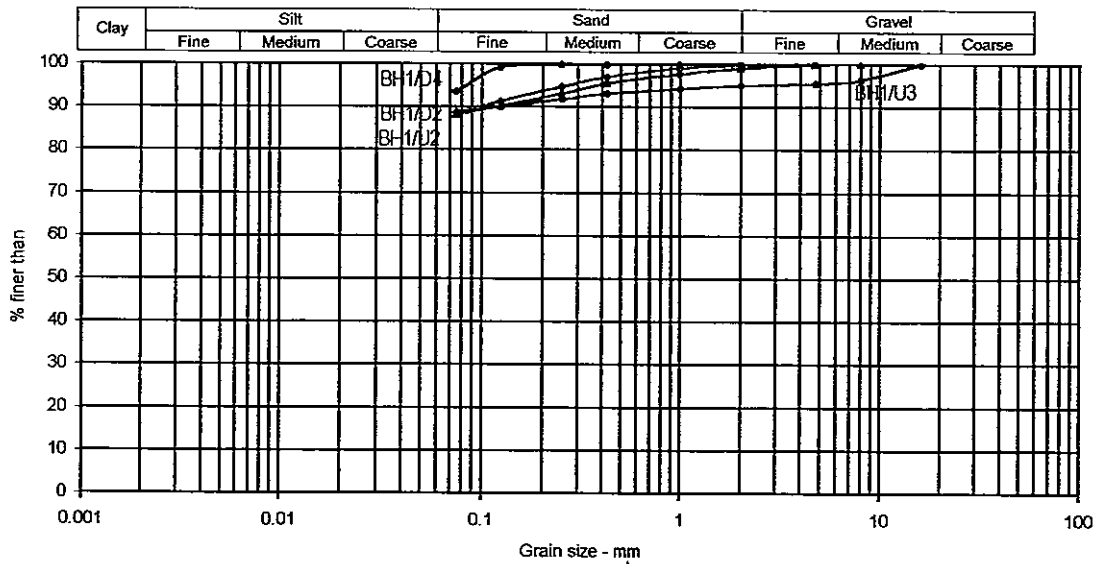

Grain size analysis and distribution curve

BH1/U4		BH1/D5		BH1/U5		BH1/D6	
d	% finer	d	% finer	d	% finer	d	% finer
75.0		75.0		75.0		75.0	
37.5		37.5		37.5		37.5	
19.0		19.0		19.0		19.0	
16.0		16.0		16.0		16.0	
8.0		8.0		8.0	100.00	8.0	
4.8	100.00	4.8	100.00	4.8	98.70	4.8	100.00
2.0	99.96	2.0	99.96	2.0	91.17	2.0	99.60
1.0	99.88	1.0	99.82	1.0	82.65	1.0	98.81
0.425	99.83	0.425	99.77	0.425	64.88	0.425	94.16
0.250	99.76	0.250	99.68	0.250	47.77	0.250	50.72
0.125	99.66	0.125	99.55	0.125	31.38	0.125	28.23
0.075	97.95	0.075	99.33	0.075	26.58	0.075	23.24
0.030	38.50	0.030		0.030	10.5	0.030	
0.0217	34.00	0.0217		0.0217	9.0	0.0217	
0.0154	29.50	0.0154		0.0154	7.0	0.0154	
0.0114	28.00	0.0114		0.0114	6.5	0.0114	
0.0081	25.00	0.0081		0.0081	6.0	0.0081	
0.0058	22.00	0.0058		0.0058	5.0	0.0058	
0.0041	20.00	0.0041		0.0041	4.5	0.0041	
0.0034	17.00	0.0034		0.0034	4.0	0.0034	
0.0021	14.00	0.0021		0.0021	3.5	0.0021	
0.0013	11.00	0.0013		0.0013	3.0	0.0013	

GRAIN SIZE DISTRIBUTION

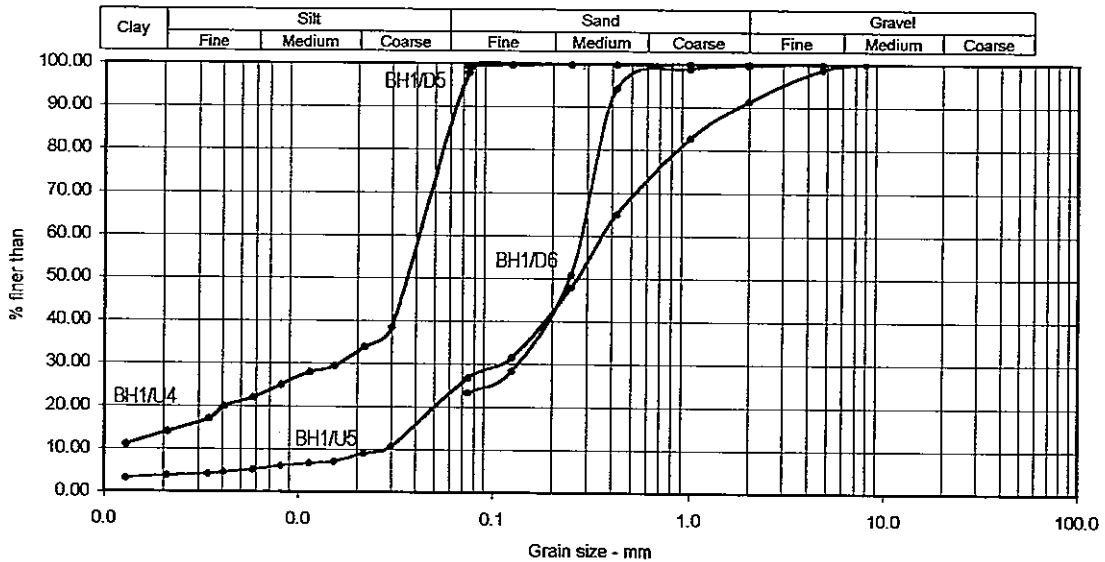

Grain size analysis and distribution curve

BH1/D7		BH1/U1		BH1/D20		BH1/D	
d	% finer	d	% finer	d	% finer	d	% finer
75.0		75.0		75.0		75.0	
37.5		37.5		37.5		37.5	
19.0		19.0	100	19.0		19.0	
16.0		16.0	85.24	16.0		16.0	
8.0	100.00	8.0	74.39	8.0		8.0	
4.8	99.65	4.8	72.57	4.8		4.8	
2.0	94.89	2.0	69.00	2.0		2.0	
1.0	86.37	1.0	65.95	1.0		1.0	
0.425	72.63	0.425	61.60	0.425		0.425	
0.250	49.92	0.250	57.39	0.250		0.250	
0.125	38.82	0.125	52.73	0.125		0.125	
0.075	37.16	0.075	50.38	0.075		0.075	
0.030		0.030	38.00	0.030		0.030	
0.0217		0.0217	35.00	0.0217		0.0217	
0.0154		0.0154	32.50	0.0154		0.0154	
0.0114		0.0114	30.00	0.0114		0.0114	
0.0081		0.0081	27.50	0.0081		0.0081	
0.0058		0.0058	25.00	0.0058		0.0058	
0.0041		0.0041	22.00	0.0041		0.0041	
0.0034		0.0034	19.00	0.0034		0.0034	
0.0021		0.0021	16.00	0.0021		0.0021	
0.0013		0.0013	12.50	0.0013		0.0013	

GRAIN SIZE DISTRIBUTION

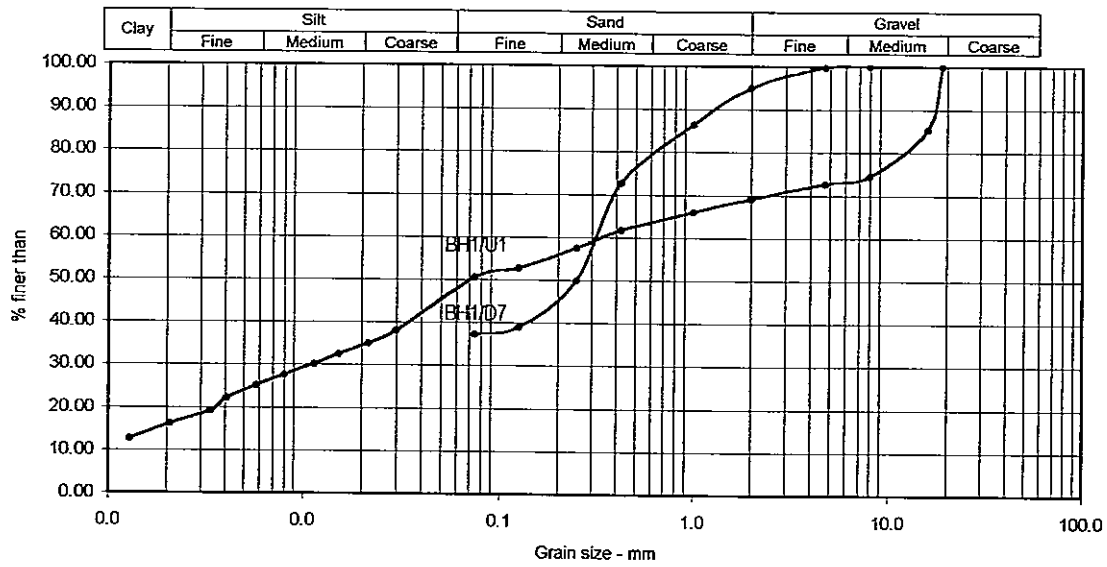

Unconfined Compression Test

Project: Construction and Improvement EDC		Initial Height L_0	75 mm	Wet soil & container (g)	73.01		
Site: Tuol SangKe		Initial Diameter D_0	35 mm	Dry soil & container (g)	63.28		
Location: BH.1		Initial Area A_0	9.62 cm^2	Weight of container (g)	14.1		
Sampling date: 27/03/04		Proving ring calibra.	0.0034 KN/div	Weight of dry soil (g)	49.18		
Tested date: 30/03/04		Rate of strain	2 %	Weight of water (g)	9.73		
Depth of sample: 2.80 - 3.25m depth		Ground water level: 2.00m		Moisture content (%)	19.78		
Description of soil: Stiff brown gray, dark gray silty clay				Bulk density (KN/m^3)	19.10		
Tested by: Chea Sereyvuth		Checked by: Sea Sochivoan		Dry density (KN/m^3)	17.41		
Proving ring dial reading (div) (1)	Proving ring dial (Unit) (2)	Deformation dial ΔL (mm) (3) = (1) $\times 10^{-2}$	Unit strain $\epsilon = \Delta L / L_0 \times 10^{-2}$ (4)	Area corrected factor (5) = (1 - ϵ)	Corrected area (cm^2) (6) = $A_0 / (1 - \epsilon)$	Applied axial load (KN) (7) = (2) $\times J_6$	Stress (Kpa) (8) = (7) / (6)
0	0	0.00	0.00	1.000	9.620	0.000	0.000
50	9	0.50	0.67	0.993	9.685	0.031	31.597
100	17	1.00	1.33	0.987	9.750	0.058	59.282
200	30	2.00	2.67	0.973	9.884	0.102	103.202
400	43	4.00	5.33	0.947	10.162	0.146	143.970
500	48	5.00	6.67	0.933	10.307	0.163	158.337
600	51	6.00	8.00	0.920	10.457	0.173	165.830
750	53	7.50	10.00	0.900	10.689	0.180	168.596
1000	42	10.00	13.33	0.867	11.100	0.143	128.649
1200		12.00	16.00	0.840	11.452	0.000	0.000
1400		14.00	18.67	0.813	11.828	0.000	0.000
1500		15.00	20.00	0.800	12.025	0.000	0.000
1600		16.00	21.33	0.787	12.229	0.000	0.000
1700		17.00	22.67	0.773	12.440	0.000	0.000
		0.00	0.00	1.000	9.620	0.000	0.000
		0.00	0.00	1.000	9.620	0.000	0.000
		0.00	0.00	1.000	9.620	0.000	0.000
		0.00	0.00	1.000	9.620	0.000	0.000
		0.00	0.00	1.000	9.620	0.000	0.000
		0.00	0.00	1.000	9.620	0.000	0.000
		0.00	0.00	1.000	9.620	0.000	0.000
		0.00	0.00	1.000	9.620	0.000	0.000

Unconfined compressive curve

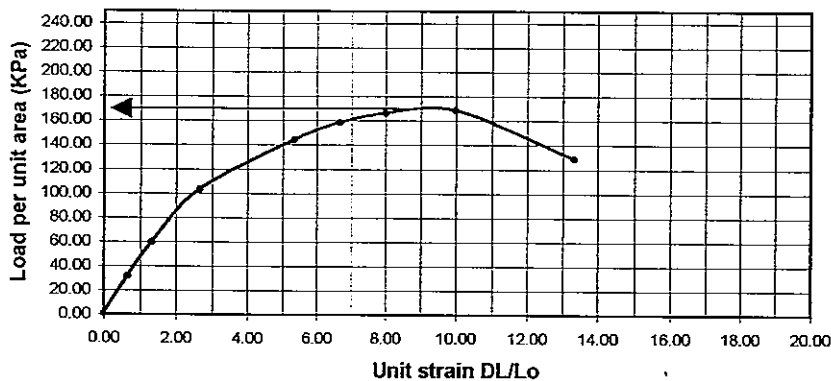

Tested result:

Unconfined compressive strength:

$q_u = 168.59 \text{ Kpa}$

Soil cohesion:

$C = q_u / 2 = 84.29 \text{ Kpa}$

Failed deformation

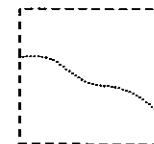

Unconfined Compression Test

Project: Construction and Improvement EDC			Initial Height L_0	80 mm	Wet soil & container (g)	59.54	
Site: Tuol Sang Ke			Initial Diameter D_0	35 mm	Dry soil & container (g)	51.16	
Location: BH.1			Initial Area A_0	9.62 cm ²	Weight of container (g)	14.4	
Sampling date: 27/03/04			Proving ring calibra.	0.0034 KN/div	Weight of dry soil (g)	36.76	
Tested date: 30/03/04			Rate of strain	2 %	Weight of water (g)	8.38	
Depth of sample: 7.60 - 8.05m depth			Ground water level: 2.00m		Moisture content (%)	22.80	
Description of soil: Stiff brown, gray, dark gray silty clay					Bulk density (KN/m ³)	20.43	
Tested by: Chea Sereyvuth			Checked by: Sea Sochivoan		Dry density (KN/m ³)	18.85	
Proving ring dial reading (div) (1)	Proving ring dial (Unit) (2)	Deformation dial ΔL (mm) (3) = (1) x 10 ⁻²	Unit strain $\epsilon = \frac{\Delta L}{L_0} \times 10^2$ (4)	Area corrected factor (5) = (1 - ϵ)	Corrected area (cm ²) (6) = $A_0 / (1 - \epsilon)$	Applied axial load (KN) (7) = (2) x J6	Stress (Kpa) (8) = (7) / (6)
0	0	0.00	0.00	1.000	9.620	0.000	0.000
50	9	0.50	0.53	0.994	9.681	0.031	31.810
100	15	1.00	1.25	0.988	9.742	0.051	52.352
200	30	2.00	2.50	0.975	9.867	0.102	103.378
400	52	4.00	5.00	0.950	10.126	0.177	174.595
500	60	5.00	6.25	0.938	10.261	0.204	198.805
600	70	6.00	7.50	0.925	10.400	0.238	228.846
750		7.50	9.38	0.906	10.615	0.000	0.000
1000	83	10.00	12.50	0.875	10.994	0.282	256.679
1200	91	12.00	15.00	0.850	11.318	0.309	273.378
1400	96	14.00	17.50	0.825	11.661	0.326	279.917
1500	100	15.00	18.75	0.813	11.840	0.340	287.162
1600	101	16.00	20.00	0.800	12.025	0.343	285.572
1700	102	17.00	21.25	0.788	12.216	0.347	283.893
1900	104	19.00	23.75	0.763	12.616	0.354	280.270
2000	104	20.00	25.00	0.750	12.827	0.354	275.676
		0.00	0.00	1.000	9.620	0.000	0.000
		0.00	0.00	1.000	9.620	0.000	0.000
		0.00	0.00	1.000	9.620	0.000	0.000
		0.00	0.00	1.000	9.620	0.000	0.000
		0.00	0.00	1.000	9.620	0.000	0.000

Unconfined compressive curve

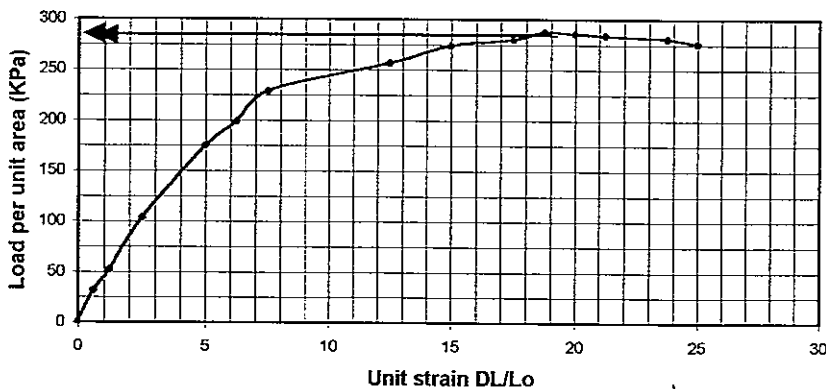

Tested result:

Unconfined compressive strength:

$q_u = 287.162 \text{ Kpa}$

Soil cohesion:

$C = q_u / 2 = 143.58 \text{ Kpa}$

Failed deformation



Unconfined Compression Test

Project: Construction and Improvement EDC		Initial Height L_0	67 mm	Wet soil & container (g)	50.98		
Site: Tuol Sang Ke		Initial Diameter D_0	35 mm	Dry soil & container (g)	41.72		
Location: BH.1		Initial Area A_0	9.62 cm^2	Weight of container (g)	14.5		
Sampling date: 27/03/04		Proving ring calibra.	0.0034 KN/div	Weight of dry soil (g)	27.22		
Tested date: 30/03/04		Rate of strain	2 %	Weight of water (g)	9.26		
Depth of sample: 10.35 - 10.80m depth		Ground water level: 2.00m		Moisture content (%)	34.02		
Description of soil: Firm dark gray silty clay				Bulk density (KN/m^3)	20.16		
Tested by: Chea Sereyvuth		Checked by: Sea Sochivoan		Dry density (KN/m^3)	18.45		
Proving ring dial reading (div) (1)	Proving ring dial (Unit) (2)	Deformation dial ΔL (mm) (3) = (1) $\times 10^{-2}$	Unit strain $\epsilon = \Delta L / L_0 \times 10^3$ (4)	Area corrected factor (5) = $(1 - \epsilon)$	Corrected area (cm^2) (6) = $A_0 / (1 - \epsilon)$	Applied axial load (KN) (7) = (2) $\times J_6$	Stress (Kpa) (8) = (7) / (6)
0	0	0.00	0.00	1.000	9.620	0.000	0.000
50	1	0.50	0.75	0.993	9.692	0.003	3.508
100	2	1.00	1.49	0.985	9.766	0.007	6.963
200	5	2.00	2.99	0.970	9.916	0.017	17.141
400	13	4.00	5.97	0.940	10.231	0.044	43.203
500	17	5.00	7.46	0.925	10.396	0.058	55.599
600	21	6.00	8.96	0.910	10.566	0.071	67.574
750	25	7.50	11.19	0.888	10.833	0.085	78.467
1000	32	10.00	14.93	0.851	11.308	0.109	98.217
1200	34	12.00	17.91	0.821	11.719	0.116	98.644
1400	34	14.00	20.90	0.791	12.161	0.116	95.057
1500	34	15.00	22.39	0.776	12.395	0.116	93.263
1600		16.00	23.88	0.761	12.638	0.000	0.000
1700		17.00	25.37	0.746	12.891	0.000	0.000
		0.00	0.00	1.000	9.620	0.000	0.000
		0.00	0.00	1.000	9.620	0.000	0.000
		0.00	0.00	1.000	9.620	0.000	0.000
		0.00	0.00	1.000	9.620	0.000	0.000
		0.00	0.00	1.000	9.620	0.000	0.000
		0.00	0.00	1.000	9.620	0.000	0.000
		0.00	0.00	1.000	9.620	0.000	0.000
		0.00	0.00	1.000	9.620	0.000	0.000
		0.00	0.00	1.000	9.620	0.000	0.000

Unconfined compressive curve

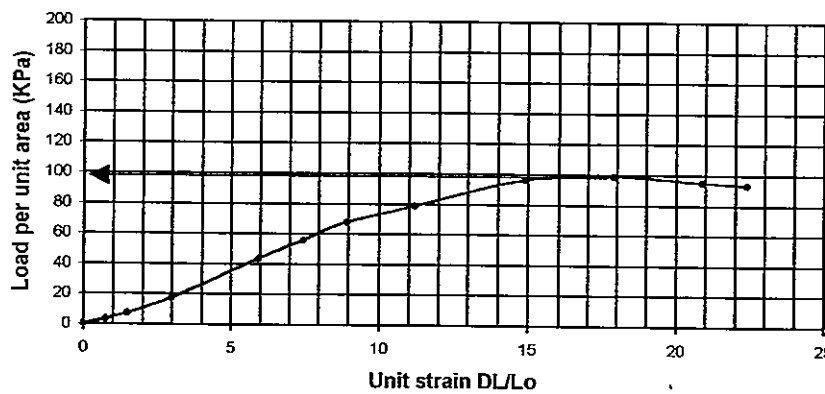

Tested result:

Unconfined compressive strength:

$q_u = 98.64 \text{ Kpa}$

Soil cohesion:

$C = q_u / 2 = 49.32 \text{ Kpa}$

Failed deformation

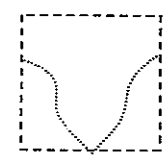

Unconfined Compression Test

Project: Construction and Improvement EDC		Initial Height L_0	77.5 mm	Wet soil & container (g)	74.84		
Site: Tuol Sang Ke		Initial Diameter D_0	35 mm	Dry soil & container (g)	64.1		
Location: BH.1		Initial Area A_0	9.62 cm^2	Weight of container (g)	14.2		
Sampling date: 27/03/04		Proving ring calibra.	0.0034 KN/div	Weight of dry soil (g)	49.9		
Tested date: 30/03/04		Rate of strain	2 %	Weight of water (g)	10.74		
Depth of sample: 4.80 - 5.25m depth		Ground water level: 2.00m		Moisture content (%)	21.52		
Description of soil: Stiff brown, dark gray, gray silty clay				Bulk density (KN/m^3)	20.57		
Tested by: Chea Sereyvuth		Checked by: Sea Sochivoan		Dry density (KN/m^3)	18.58		
Proving ring dial reading (div) (1)	Proving ring dial (Unit) (2)	Deformation dial ΔL (mm) (3) = (1) $\times 10^{-2}$	Unit strain $\epsilon = \frac{\Delta L}{L_0} \times 10^{-2}$ (4)	Area corrected factor (5) = $(1 - \epsilon)$	Corrected area (cm^2) (6) = $A_0 / (1 - \epsilon)$	Applied axial load (KN) (7) = (2) $\times J_6$	Stress (kpa) (8) = (7) / (6)
0	0	0.00	0.00	1.000	9.620	0.000	0.000
50	12	0.50	0.65	0.994	9.682	0.041	42.138
100	25	1.00	1.29	0.987	9.746	0.085	87.217
200	41	2.00	2.58	0.974	9.875	0.139	141.167
400	62	4.00	5.16	0.948	10.144	0.211	207.817
500	72	5.00	6.45	0.935	10.283	0.245	238.052
600	82	6.00	7.74	0.923	10.427	0.279	267.376
750	86	7.50	9.68	0.903	10.651	0.292	274.536
1000	106	10.00	12.90	0.871	11.045	0.360	326.296
1200	117	12.00	15.48	0.845	11.382	0.398	349.486
1400	122	14.00	18.06	0.819	11.741	0.415	353.294
1500	130	15.00	19.35	0.806	11.929	0.442	370.532
1600	133	16.00	20.65	0.794	12.123	0.452	373.017
1700	137	17.00	21.94	0.781	12.323	0.466	377.988
1800	136	18.00	23.23	0.768	12.530	0.462	369.027
1900	142	19.00	24.52	0.755	12.744	0.483	378.632
2000	142	20.00	25.81	0.742	12.966	0.483	372.356
		0.00	0.00	1.000	9.620	0.000	0.000
		0.00	0.00	1.000	9.620	0.000	0.000
		0.00	0.00	1.000	9.620	0.000	0.000
		0.00	0.00	1.000	9.620	0.000	0.000

Unconfined compressive curve

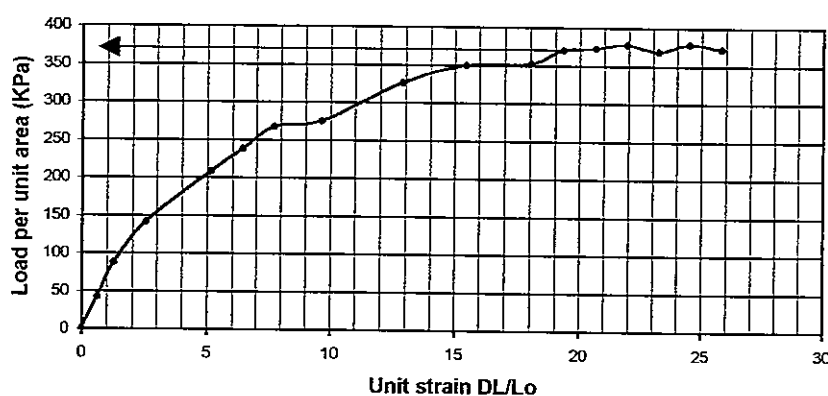

Tested result:

Unconfined compressive strength:
 $q_u = 377.988$ Kpa

Soil cohesion:
 $C = q_u / 2 = 188.99$ Kpa

Failed deformation

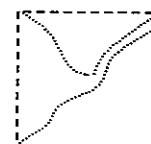

Consolidation Test

Project: Construction and Improvement of Diesel Engine Generators of EDCC5 Site: Tuol Sangke, Phnom Penh Location: BH.1				Sample description: Soft brown gray sandy clay				Sampling Date: 27/03/04		Tested Date: 01/04/04	
				Depth of ground water: 2.00m				Sample No: U2		Tested by: Sereyvuth	
				Depth: 4.5 m				Checked: Sochivoan			
Test ring				Initial moisture content							Specific gravity
Diameter	Area	Height	Weight	Volume	Tin No.	Weight of Tin & Soil		Weight of	Weight of	Moisture	Gs
Dr	Ar	Hr	Wr	Vr	21	Wet	Dry	Dry Soil	Water	content	
cm	cm ²	cm	g	cm ³	Wt of tin.g	g	g	g	g	%	
50.00	19.64	2.00	53.54	39.27	14.30	70.70	60.84	46.54	9.86	21.19	2.69
Testing Start											
Wt of ring & sample	Weight of wet sam	Wet Bulk Density	Wt. Of dry sample	Dry Density	Volume of solids	Height of solids	Height of Voids	Init-Voids Ratio	Saturation Ratio	Effective Pressure: d-depth of sample : hw-height of ground water above sample Po= (gb*d-hw)*10 Kpa Po = 63.2 Kpa	
W	Wb=W-Wt	gb=W _b /Vr	Ws = wb/(1+w)	gb=Ws/Vr	Vs= Ws/Gs*γ _w	Hs=Vs/Ar	Hv=Hr-Hs	e _i =Hv/Hs	Si=(Wb-Ws)/H*Ar		
g	g	g/cm ³	g	g/cm ³	cm ³	cm	cm	%	%		
129.50	75.96	1.93	62.68	1.60	23.30	1.19	0.81	0.69	0.83		
Calculations											
Stage	1	2	3	4	5	6	<p style="text-align: center;">Consolidation test</p>				
Stress P ₁ (Kpa)	25	50	100	200	400	25					
Ho -mm	19.9	19.8	19.7	19.6	19.4	19.5					
ΔH (mm)	0.10	0.22	0.34	0.43	0.56	0.50					
H ₁ = Ho -ΔH (mm)	19.8	19.6	19.3	19.1	18.9	19.0					
e ₀ =(Ho/Hs)-1	0.67	0.66	0.65	0.64	0.63	0.64					
Δe = (ΔH/Hs)	0.01	0.02	0.03	0.04	0.05	0.04					
e ₁ = e ₀ -Δe	0.66	0.64	0.62	0.61	0.59	0.60					
ΔP = (P ₁ -Po) (Kpa)	25.0	25.0	50	100	200	375					
a _v =(Δe/ΔP*100) m ² /min	0.03	0.07	0.06	0.04	0.02	0.01					
m _v =a _v /(1+e ₀) m ² /min	0.02	0.04	0.03	0.02	0.01	0.01					
H _d =(H ₀ +H ₁)/4 (mm)	9.93	9.84	9.75	9.68	9.58	9.63					
t ₅₀ min	2.3	2.30	2.10	2.20	2.30	2.50					
Cv mm ² /min Cv= 0,197*Hd ² /t ₅₀	8.44	8.28	8.91	8.39	7.86	7.30					
End of Test											
Weight of ring and sample		Weight of dry soil	Weight of water	Final moist-con	Final saturation	Design values					
Wet	Dry	Wd	Ww	Wf	Sf	Design pressure range: 50 Kpa to 100 Kpa					
I	J	J-Wf	I-J	Ww/Wd	Ww/(Hf*Ar-Wd)/Gs	mv = ...0.58x10 ⁻³ ...m ² /s					
						Cv = ...1.43x10 ⁻⁷ ...m ² /s					
						K = Cv*mv*0,01 m/s =...0.8 x 10 ⁻¹² ...m/s					
Remarks:											

Consolidation Test

Project: Construction and Improvement of Diesel Engine Generators of EDCC5				Sample description: Soft brown gray sandy clay				Sampling Date: 27/03/04		Tested Date: 01/04/04	
Site: Tuol Sangke, Phnom Penh				Depth of ground water: 2.00m				Sample No: U3		Tested by: Sereyvuth	
Location: BH.1								Depth: 7.00 m		Checked: Sochivoan	
Test ring				Initial moisture content							Specific gravity
Diameter	Area	Height	Weight	Volume	Tin No.	Weight of Tin & Soil		Weight of	Weight of	Moisture	Gs
Dr	Ar	Hr	Wr	Vr	24	Wet	Dry	Dry Soil	Water	content	
cm	cm ²	cm	g	cm ³	Wt of tin.g	g	g	g	g	%	g/cm ³
50.00	19.64	2.00	53.54	39.27	14.50	78.40	67.20	52.70	11.20	21.25	2.69
Testing Start											
Wt of ring & sample	Weight of wet sam	Wet Bulk Density	Wt. Of dry sample	Dry Density	Volume of solids	Height of solids	Height of Voids	Init-Voids Ratio	Saturatio n Ratio	Effective Pressure: d-depth of sample : hw-height of ground water above sample	
W	Wb=W-Wt	gb=W _b /Vr	Ws = wb/(1+w)	gb=Ws/Vr	Vs= Ws/Gs*γw	Hs=Vs/Ar	Hv=Hr-Hs	e _v =Hv/Hs	Si=(Wb-Ws)/Hv*Ar	Po= (gb*d-hw)*10 Kpa Po = 89.8 Kpa	
g	g	g/cm ³	g	g/cm ³	cm ³	cm	cm	%	%		
133.21	79.67	2.03	65.71	1.67	24.43	1.24	0.76	0.61	0.94		
Calculations											
Stage	1	2	3	4	5	6	7	8	<p style="text-align: center;">Consolidation Test</p>		
Stress P ₁ (Kpa)	25	50	100	200	400	25					
H ₀ -mm	19.9	19.9	19.8	19.7	19.5	19.6					
ΔH (mm)	0.11	0.10	0.18	0.26	0.48	0.40					
H ₁ = H ₀ - ΔH (mm)	19.8	19.8	19.6	19.5	19.0	19.2					
e ₀ = (H ₀ /Hs) - 1	0.60	0.60	0.60	0.59	0.57	0.58					
Δe = (ΔH/Hs)	0.01	0.01	0.01	0.02	0.04	0.03					
e ₁ = e ₀ - Δe	0.60	0.60	0.58	0.57	0.54	0.55					
ΔP = (P ₁ - P ₀) (Kpa)	25.0	25.0	50	100	200	375					
a _v = (Δe/ΔP*100) m ² /min	0.04	0.03	0.03	0.02	0.02	0.01					
m _v = a _v / (1 + e ₀) m ² /min	0.02	0.02	0.02	0.01	0.01	0.01					
H _d = (H ₀ + H ₁) / 4 (mm)	9.92	9.93	9.87	9.81	9.64	9.70					
t ₅₀ min	2.5	2.20	2.20	2.50	2.60	2.70					
C _v mm ² /min	7.75	8.82	8.71	7.58	7.04	6.87					
C _v = 0,197*H _d ² /t ₅₀											
End of Test											
Weight of ring and sample		Weight of dry soil	Weight of water	Final moist-con	Final saturation		Design values				
Wet	Dry	Wd	Ww	Wf	Sf		Design pressure range: 100 Kpa to 200 Kpa				
I	J	J-Wf	I-J	Ww/Wd	Ww/(Hf*Ar-Wd)/Gs		mv = ...0.25x10 ⁻³ ...m ² /s				
							Cv = ...1.4x10 ⁻⁷ ...m ² /s				
							K = Cv*mv*0,01 m/s =0.35 x 10 ⁻¹²m/s				
Remarks:											

C.E.B.T.P

BHN°1

U₁

Site EDC

STRAIGHT SHEARING TEST

Sounding :

Sample :

Depth : 2.10-3.00 m

Non Strengthened
 Speed of Shearing :
 ↗ Fast
 ↘ Slow

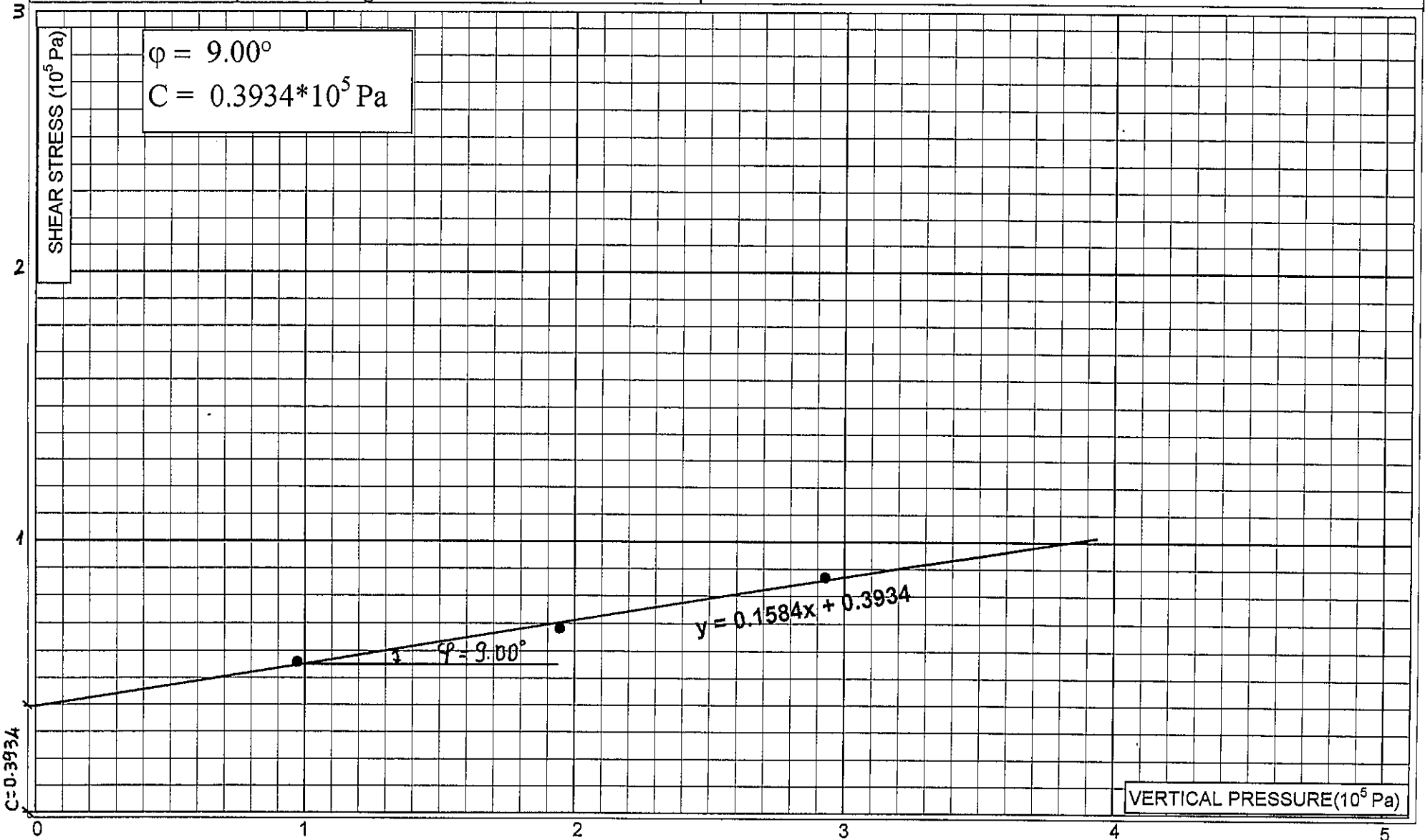

20
A11-23

C = 0.3934

VERTICAL PRESSURE (10⁵ Pa)

Nota : 1*10⁵Pa = 1bar = 1daN/cm²

C.E.B.T.P

BHN°1

U₂

Site EDC

STRAIGHT SHEARING TEST

Sounding :

Sample :

Depth : 4.00-4.80 m

Non Strengthened
 Speed of Shearing :
 ↗ Fast
 ↘ Slow

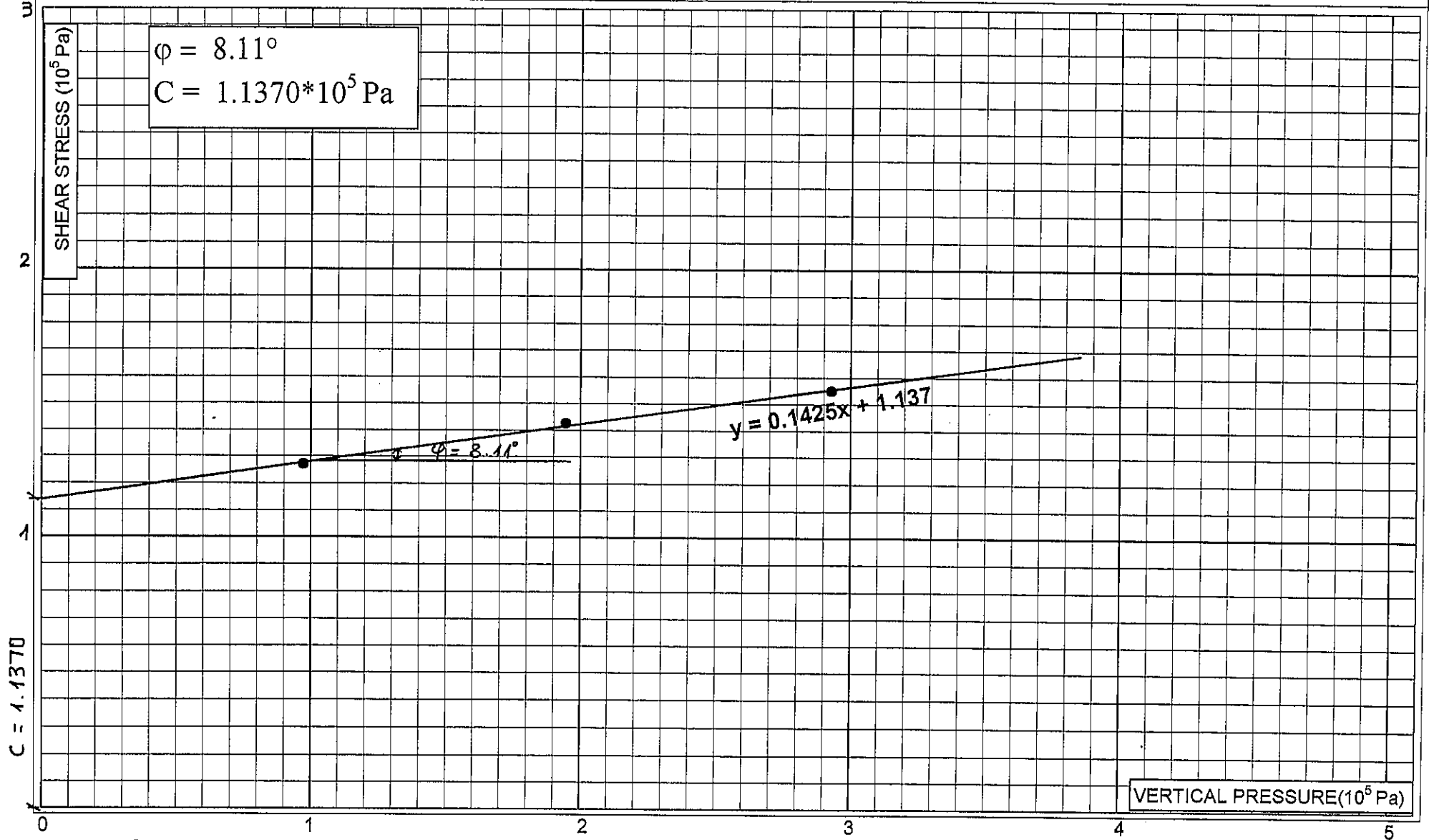

VERTICAL PRESSURE(10⁵ Pa)

Nota : 1*10⁵Pa = 1bar = 1daN/cm²

21
A11-24

C.E.B.T.P

BHN°1

U₃

Site

EDC

STRAIGHT SHEARING TEST

Sounding :

Sample :

Depth : 6.80-7.60 m

Non Strengthened
 Speed of Shearing :
 ↗ Fast
 ↘ Slow

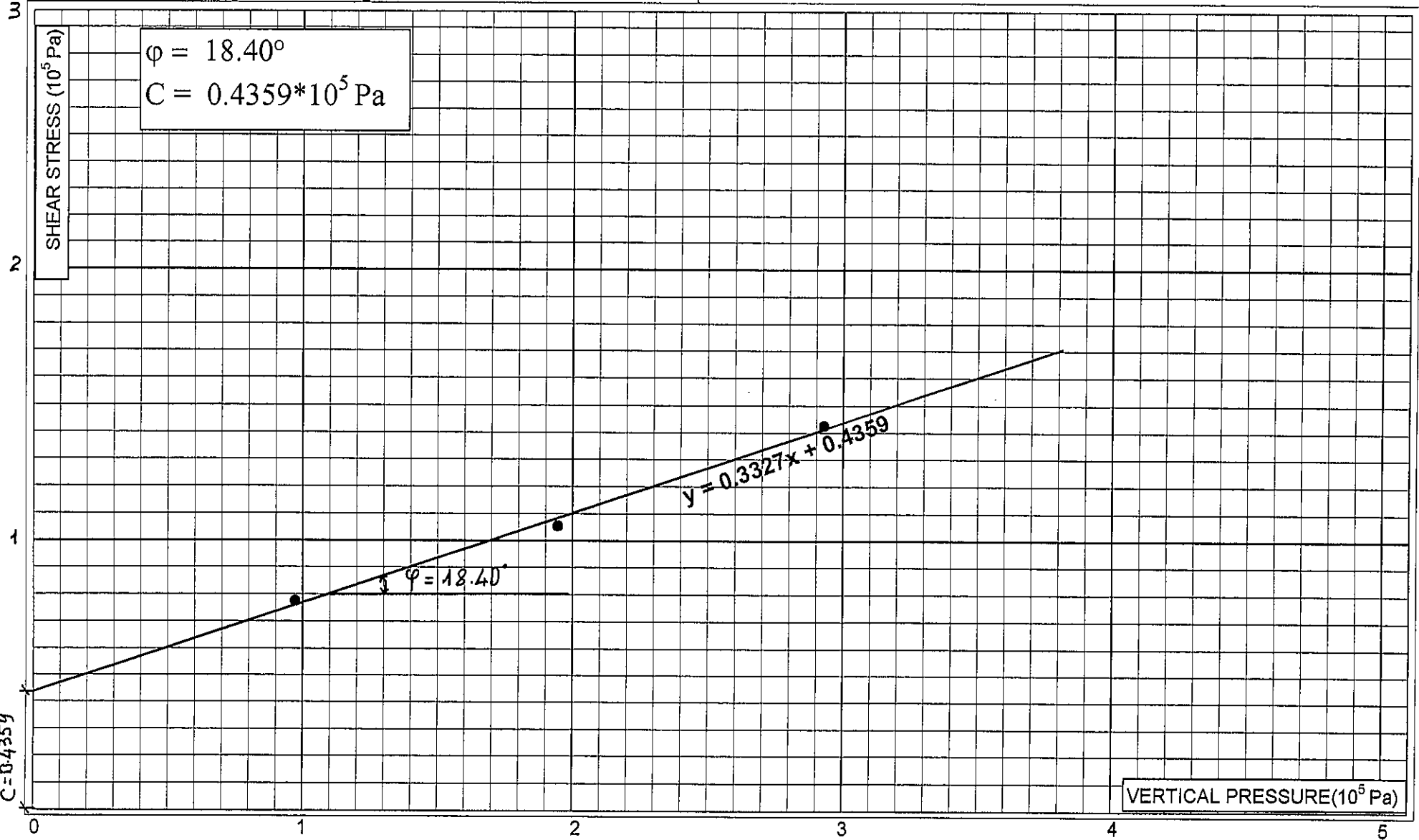

22
A11-25

Nota : $1 \cdot 10^5 \text{ Pa} = 1 \text{ bar} = 1 \text{ daN/cm}^2$

C.E.B.T.P

BHN°1

U₄

Site EDC

STRAIGHT SHEARING TEST

Sounding :

Sample :

Depth : 9.55-10.30 m

Non Strengthened
 Speed of Shearing :
 Fast
 Slow

SHEAR STRESS (10⁵ Pa)

$\phi = 14.22^\circ$
 $C = 0.4975 \cdot 10^5 \text{ Pa}$

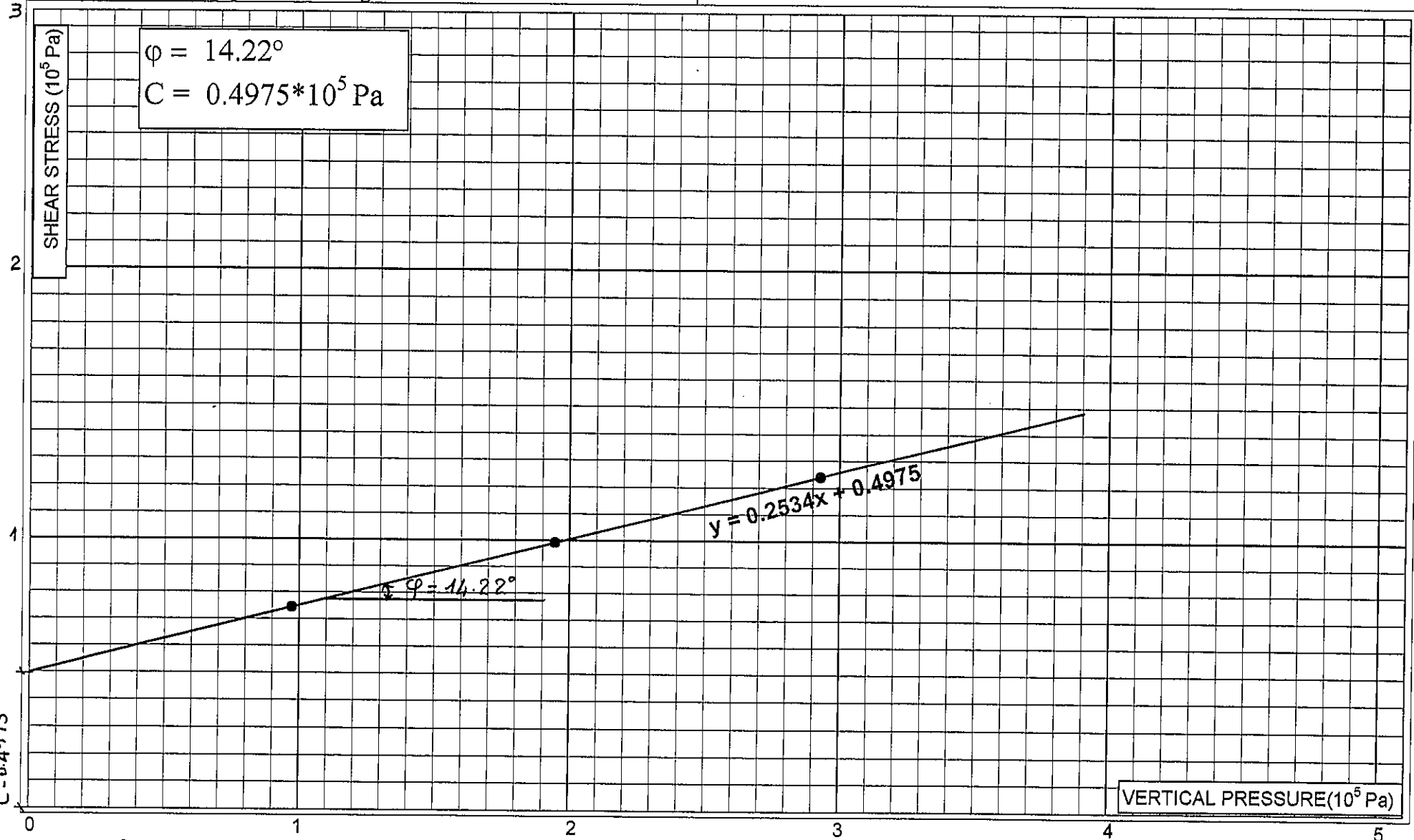

VERTICAL PRESSURE(10⁵ Pa)

Nota : 1*10⁵Pa = 1bar = 1daN/cm²

23
A11-26

C.E.B.T.P

BHN°1

U₅

Site EDC

STRAIGHT SHEARING TEST

Sounding :

Sample :

Depth : 12.30-13.10 m

Non Strengthened
 Speed of Shearing :
 Fast
 Slow

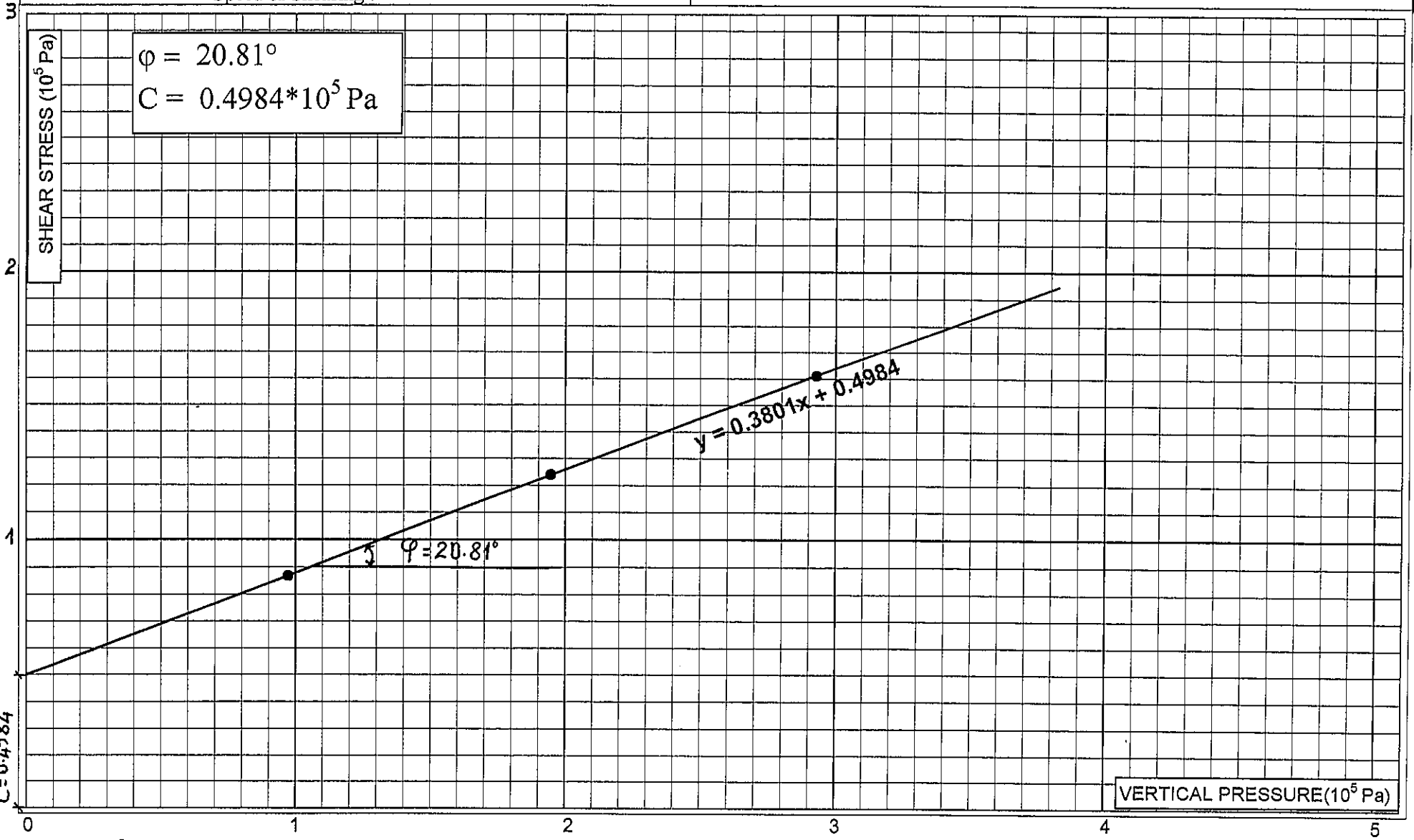

$\phi = 20.81^\circ$
 $C = 0.4984 \cdot 10^5 \text{ Pa}$

$y = 0.3801x + 0.4984$

$\phi = 20.81^\circ$

C = 0.4984

VERTICAL PRESSURE(10⁵ Pa)

Nota : 1*10⁵Pa = 1bar = 1daN/cm²

2.4
A11-27

Construction and Improvement of Diesel Engine Generator of EDC C5 Power Plant Project (Borehole Log)

BORING: BH.1 STA:
SHEET 1 OF 1
DATE 27/03/04

CASING SIZE : 150 mm VANE SIZE: CORE SIZE: UND. SAMPLER SIZE: 70mm

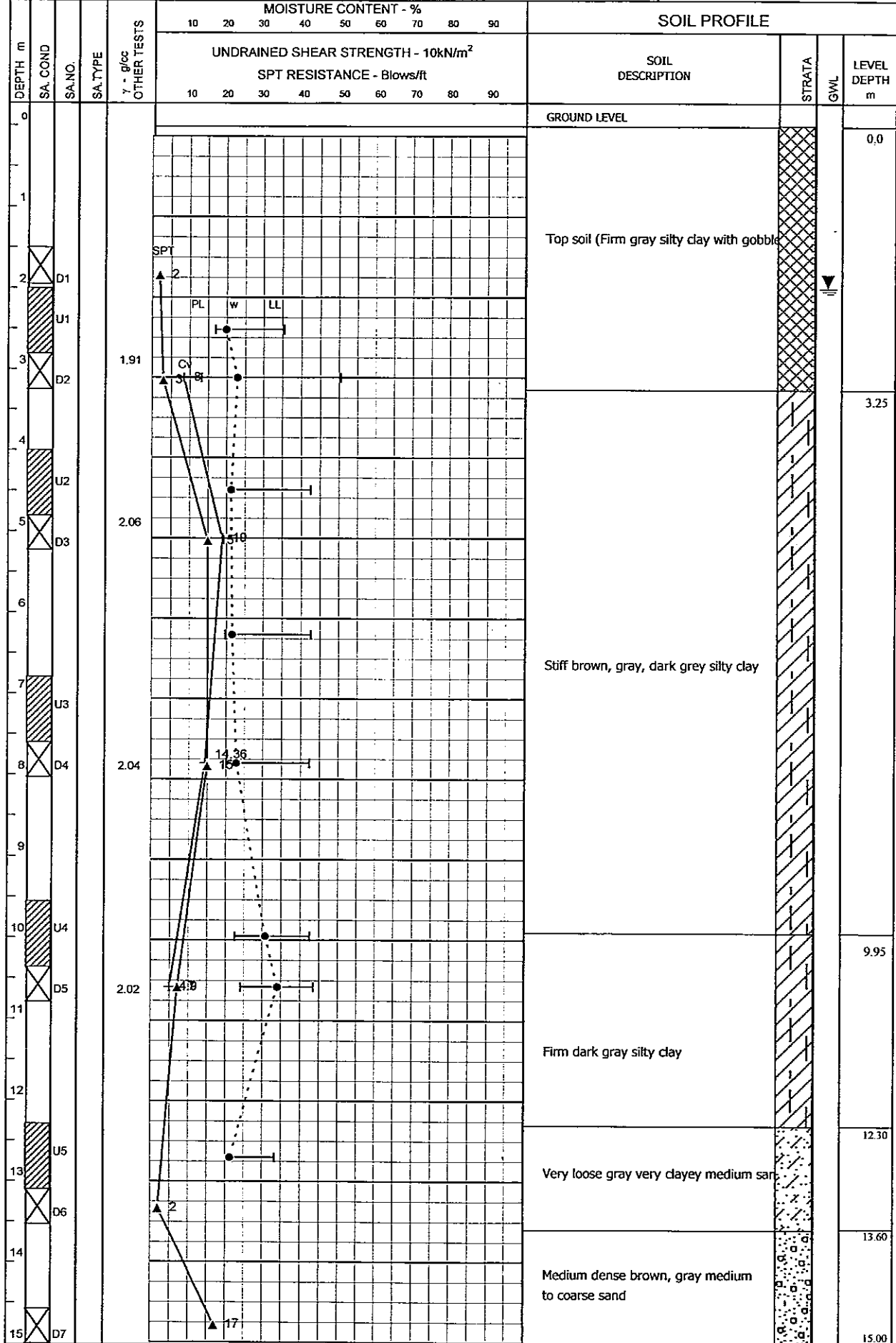

Figure 8. Photographs

1. Boring Operation



2. SPT Test



3. Soil Sampling

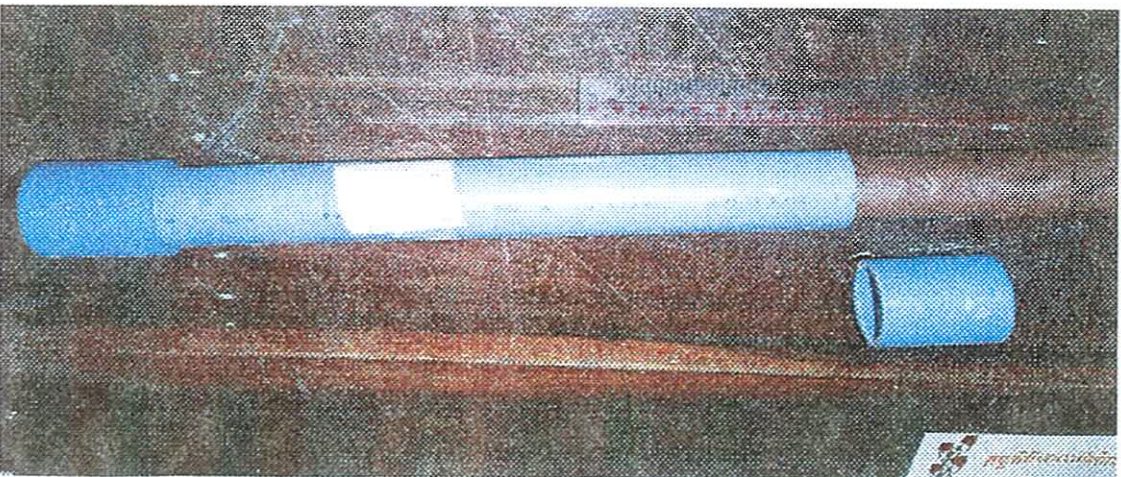

4. Laboratory Testing

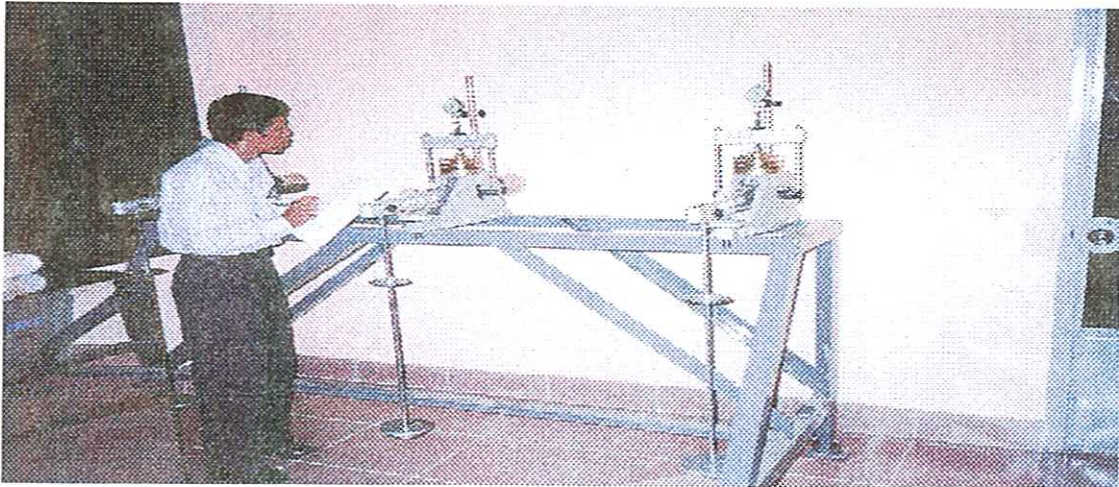

VI. Appendix-B (Plate Test)

I. General

1. Introduction

Soil investigation is a requirement for detail engineering design of structures and construction. It is to determine subsoil conditions beneath the project site and physical and geo-technical characteristics of the underlying soil strata. However in this project, field test was recommended to use. These provide economical cost and safety of construction structure.

2. Objective and Scope

The objective of soil investigation is contributed to computing bearing capacity under real condition of soil for shallow foundation including their characteristics of settlement beneath the project area. The scopes and the objectives of the subsoil investigation included the following tasks:

- Made an actual field observation and inspection.
- Plate Test undertaken at the proposed location site by the engineer.
- Interpretation and evaluation of the field and computing test results.
- Determined and evaluated the bearing capacity and settlement of soil for the purpose of getting a conclusive data to support the recommendation for the construction.

II. Geo-technical Investigation

Angkor Wat Engineering and Construction Company was commissioned to undertake geo-technical investigation for this particular project for the determination of depth condition of embedded foundation, consistency, bearing capacity, settlement and foundation type.

1. Site Operation

Subsurface exploration was carried out to determine the estimation of the bearing capacity of soil in place by mean of field loading tests. The test is used hydraulic jack to transfer load to steel plate at the propose area of testing place. The field operations were carried out in accordance with ASTM D1194 Standards.

The main activities of the whole field investigations consisted of the following tasks:

- Located the pit to the required position.
- Dug the pit of some 1meter by 1meter until the depth equal to which is foundation depth.
- Cleaned the pit and made it horizontally at the bottom.
- Put some sands to the bottom of pit and scrapped it horizontally.
- Installed the plate apparatus in the right position and observed the stable ground touched the steel plate.
- Started transferring load to the plate and settlements were recorded from a dial gauge.
- The sub-stress increment was changing every 50KPa for the period of 15mn and the stress increment ranging respectively each 200KPa for the period of 1hour.
- The test continued until a total settlement of 25mm is obtained, or until the capacity of the testing apparatus is reached.

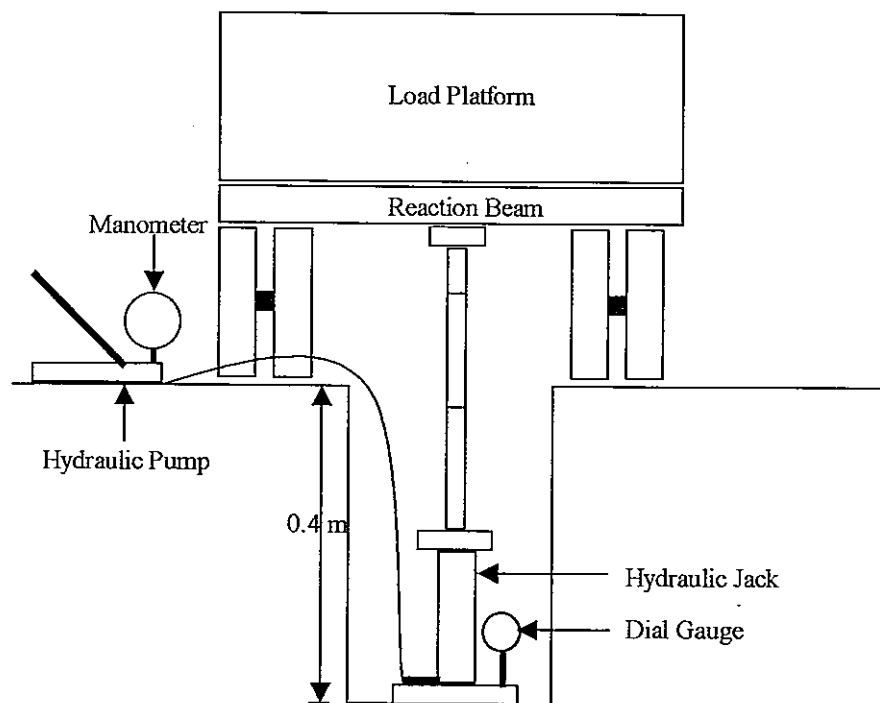

Figure.1 Typical Setup for Conducting Static Load Tests.

2. Bearing Capacity of Soil

Theoretically the bearing capacity of foundation can be taken from the curve of settlement (25mm) versus load stress (KPa) when the curve parallel to which is settlement ordinate. In the studied case, the rupture was not reached; it is difficult to precise the curve. Therefore the ultimate bearing capacity of footing foundation equal to the load stress of plate, is supposed to embed at the same level the test depth.

Table.1

Test No.	Footing Size (m ²)	Depth (m)	Ultimate Bearing Capacity (KPa)	Allowable Bearing Capacity (KPa)
Pl.1	1.5m x 1.5m	0.4 m	600	200

Table.2

Test No.	Footing Size (m ²)	Depth (m)	Settlement While Testing (mm)	Settlement of Footing Found.(mm)
Pl.1	1.5m x 1.5m	0.4 m	0.7	1.167



III. Conclusion

The test started during the period of dry season, the ground water table was not met therefore. Referring to the boring hole at the other side, it is leveled at the depth of 8.5m beneath the project area and it increase to the level of 2m below ground surface level after 24h measuring. The soil seeing at the bottom of the dug pit is clay, which does not absorb easily water when underground water level comes up during rainy season. Field operation and interpretation show the strength bearing capacity of soil depending on the settlement. Normally the ultimate bearing capacity can be interpreted from load transferring to the steel plate until settlement of 25mm. In the investigated case the sinks was not reached 25mm. So the ultimate bearing capacity is complicated to determine and than the maximum stress of plate apparatus was recorded to terminate the bearing capacity. The conclusion is that the test No.1 featured the over consolidated soil, the upper layer only, in the existing building. The bearing capacity of the soil at the depth of 0.4 meter is 200KPa.

Figure 9. Photographs of Plate Test



VII.Appendix-C(Coring and Compression Test of Concrete)

ELECTRICITY RESTORATION PROJECT ,CAMBODIA										
CONCRETE COMPRESSIVE STRENGTH (T-22)										
Concrete Class: x			Date Moulded: x			RFI No. x		batch plan Location: x		
Structure Location: machinery footing			Structure No. C1, C2, C3, C4			Lab.No. 206 STGI/04				
Curing Lab/Field : X										
Cylinder No.	Testing date	Age in days	Dimensions in cm				Area (cm ²)	Load Kgf	Compressive Strength (MPa)	Type of Failure
			L	D ₁	D ₂	Av.D				
CoringNo.1	2/04/04	Over 28	17.45cm	-	-	10cm	78.54	208	27	
CoringNo.2	2/04/04	Over 28	Broken	-	-	10cm	78.54	-	-	
CoringNo.3	2/04/04	Over 28	19.60cm	-	-	10cm	78.54	232	30.12	
CoringNo.4	2/04/04	Over 28	19.85cm	-	-	10cm	78.54	182	23.62	
Tested by: CHEA Sereyvuth				Date:02/04/04		Average for x days				
Cylinder No.	Mass (g)	Volume (cm ³)	Density(g/cm ³)	Remarks						
Coring No.1	3167	1370.52	2.31							
Coring No.2	-	-	-							
Coring No.3	3541	1539.38	2.30							
Coring No.4	3530	1559.02	2.26							
Tested by: CHEA Sereyvuth				Date: 02/04/04			Average: x			
Checked by: SEA Sochivoan				Date: 03/04/04						

1 Mpa = 10 Kg/cm²

Figure 10. Photograph of Coring and Compression Test of Concrete

1. Concrete Coring



2. Compression Test

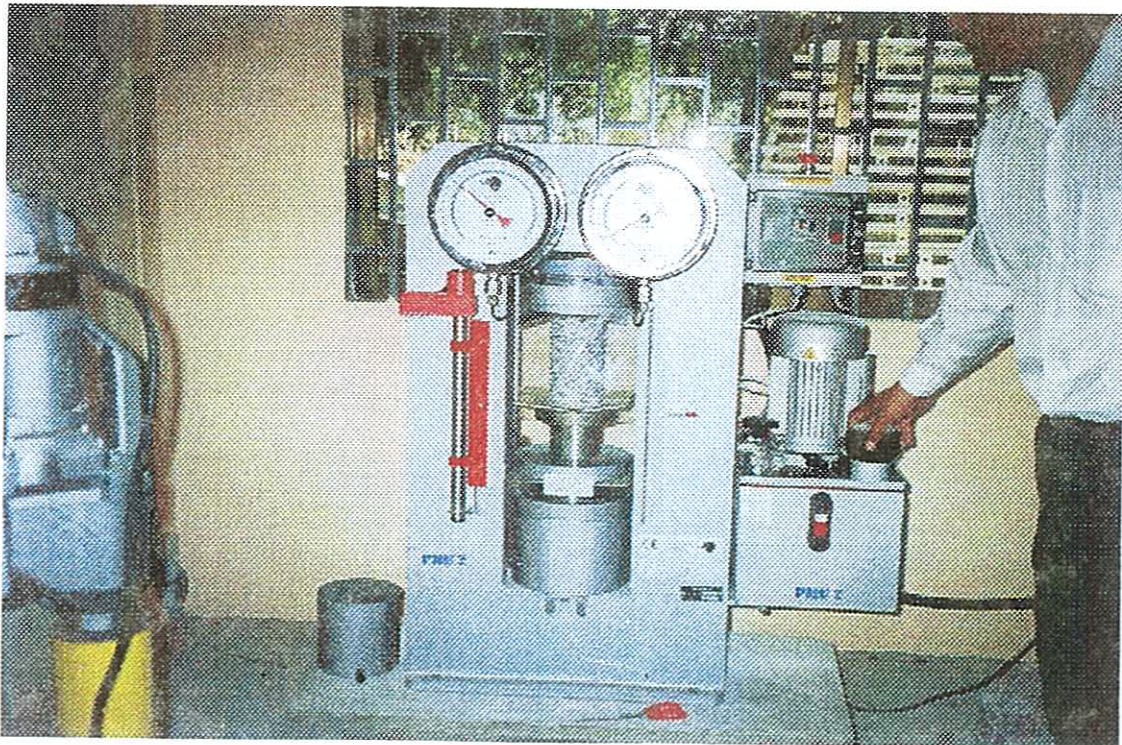
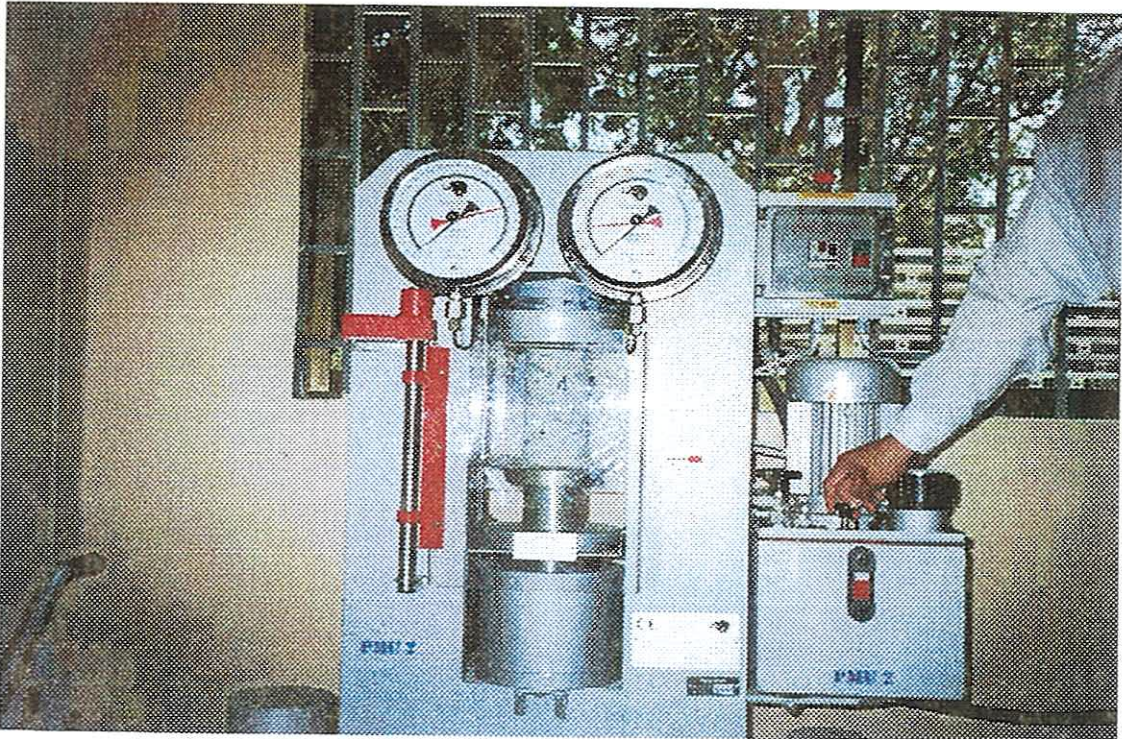

Ultimate Load Piles (KN)

Bearing capacity factors- Nq

Structure: EDC C5 Building
Borelog: BH-1
 Surface elevation 0 m
 Observed WL 2 m
 Depth to Water -2 m
 Pile Size: 0.30
 Pile Area: 0.09
 Pile Perimeter: 1.20
 Pile Spacing: 1.80
 Ratio of Horiz to Vertical Stress: 1.25
 Limit of Increase in Vertical Effective Stress: 6
 Depth of Soft Soil: 0.00 m

Sand Properties

N range	Angle Friction
0-10	28
10-20	32
20-30	34
30-40	36
40-50	38
>50	40

Clay Properties

N range	Cohesion (kN/so m)	Adhesion (kN/so m)
2-4	25	6
4-8	50	20
8-15	100	30
15-30	150	40
30-40	200	55
>40	400	65

Friction angle (phi)	Nq
26	10
28	15
30	21
31	24
32	29
33	35
34	42
35	50
36	62
37	77
38	86
39	120
40	145

From	To	Distance	Strata	SPT N	Friction Angle	Delta	Tan Delta	Nq	Density	Sub Density	Stress Increm	Vertical Stress	Clay C	Clay CA	Friction Increm	Friction	End Bearing	Ultimate Capacity
0.0	1.0	1.0	clay	2					19.10	19.10	19.10	19.10	25	6	7.2	7.2	17.6	24.8
1.0	2.0	1.0	clay	2					19.10	19.10	19.10	38.20	25	6	7.2	14.4	17.6	32.0
2.0	3.0	1.0	clay	3					19.10	9.10	9.10	47.30	25	6	7.2	21.6	17.6	39.2
3.0	4.0	1.0	clay	3					19.70	9.70	9.70	57.00	25	6	7.2	28.8	17.6	46.4
4.0	5.0	1.0	clay	15					20.10	10.10	10.10	67.10	100	30	36.0	64.8	70.2	135.0
5.0	6.0	1.0	clay	15					20.10	10.10	10.10	77.20	100	30	36.0	100.8	70.2	171.0
6.0	7.0	1.0	clay	15					20.30	10.30	10.30	87.50	100	30	36.0	136.8	70.2	207.0
7.0	8.0	1.0	clay	15					20.40	10.40	10.40	97.90	100	30	36.0	172.8	70.2	243.0
8.0	9.0	1.0	clay	7					20.40	10.40	10.40	108.30	50	20	24.0	196.8	35.1	231.9
9.0	10.0	1.0	clay	7					20.40	10.40	10.40	118.70	50	20	24.0	220.8	35.1	255.9
10.0	11.0	1.0	clay	7					20.20	10.20	10.20	128.90	50	20	24.0	244.8	35.1	279.9
11.0	12.0	1.0	clay	2					20.20	10.20	10.20	139.10	25	6	7.2	262.0	17.6	269.6
12.0	13.0	1.0	sand	2	28	21	0.3839	15	19.20	9.20	9.20	148.30			85.4	337.4	200.2	537.6
13.0	14.0	1.0	sand	2	28	21	0.3839	15	20.10	10.10	10.10	158.40			91.2	428.6	213.8	642.5
14.0	15.0	1.0	sand	17	32	24	0.4453	29	20.30	10.30	10.30	168.70			112.7	541.3	440.3	981.6
15.0	16.0	1.0	sand															
16.0	17.0	1.0	sand															
17.0	18.0	1.0	sand															
18.0	19.0	1.0	sand															
19.0	20.0	1.0	sand															



Bearing Capacity of Shallow Foundation

Depth(m):	2 m	Depth(m):	3 m	Depth(m):	4 m
Diameter/Width(m):	8 m	Diameter/Width(m):	8 m	Diameter/Width(m):	8 m
N55:	2.55	N55:	3.82	N55:	19.09
$K_d = 1 + (0,33 \times D/B) \leq 1,33$:	1.08	$K_d = 1 + (0,33 \times D/B) \leq 1,33$:	1.12	$K_d = 1 + (0,33 \times D/B) \leq 1,33$:	1.17

No.	Embedded Footing(m)	F2, (0,08)	F3, (0,3)	$((B+0,3)/B)^2$	Kd	qa (Kpa)
1	2 m	0.08	0.3	1.076	1.08	36.99
2	3 m	0.08	0.3	1.076	1.12	57.54
3	4 m	0.08	0.3	1.076	1.17	300.54

資料－12 測量調査結果

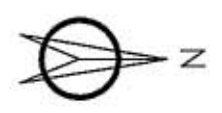
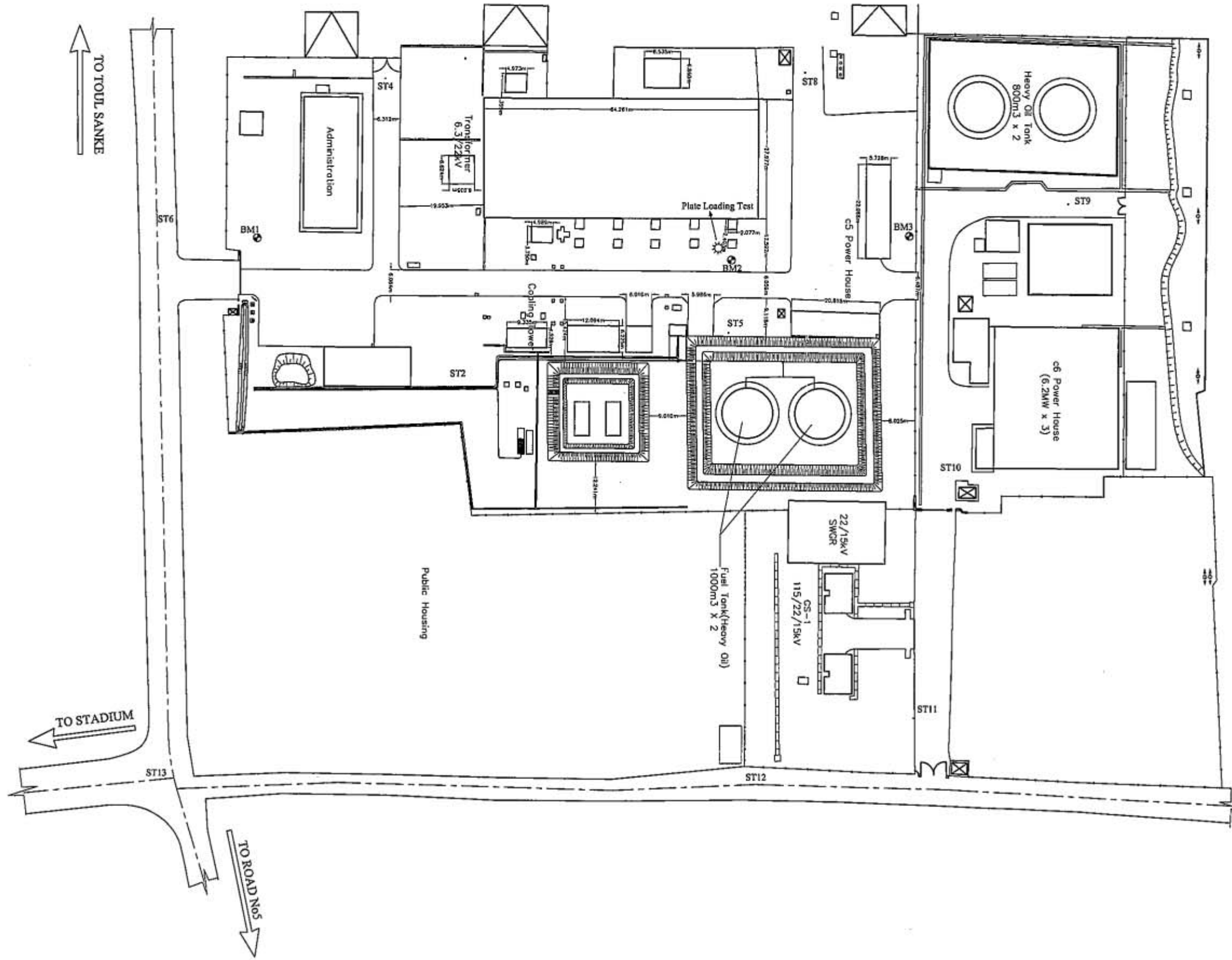

LEGEND

- FUEL TANK
- SECURITY POST
- CONCRETE BLOCK OR BUILDING
- BENCH-MARK (BM)
- STATION (STN)
- TREE
- BARBED WIRE FENCE
- CABLE LINE
- ELECTRIC POLE
- U-DRAIN

COORDINATE POINTS

POINT No	N(m)	E(m)	Z(m)
BM1	500.000	500.000	10.000
BM2	611.040	505.265	9.708
BM3	652.762	499.690	9.990
STN2	547.104	529.834	9.740
STN4	529.848	462.778	9.443
STN5	610.348	522.365	9.722
STN6	479.318	497.736	9.914
STN8	628.077	461.419	9.747
STN9	690.044	492.204	9.662
STN10	660.330	556.843	9.621
STN11	653.791	613.100	9.975
STN12	612.826	627.737	10.305
STN13	477.213	628.314	10.731

NOTE:





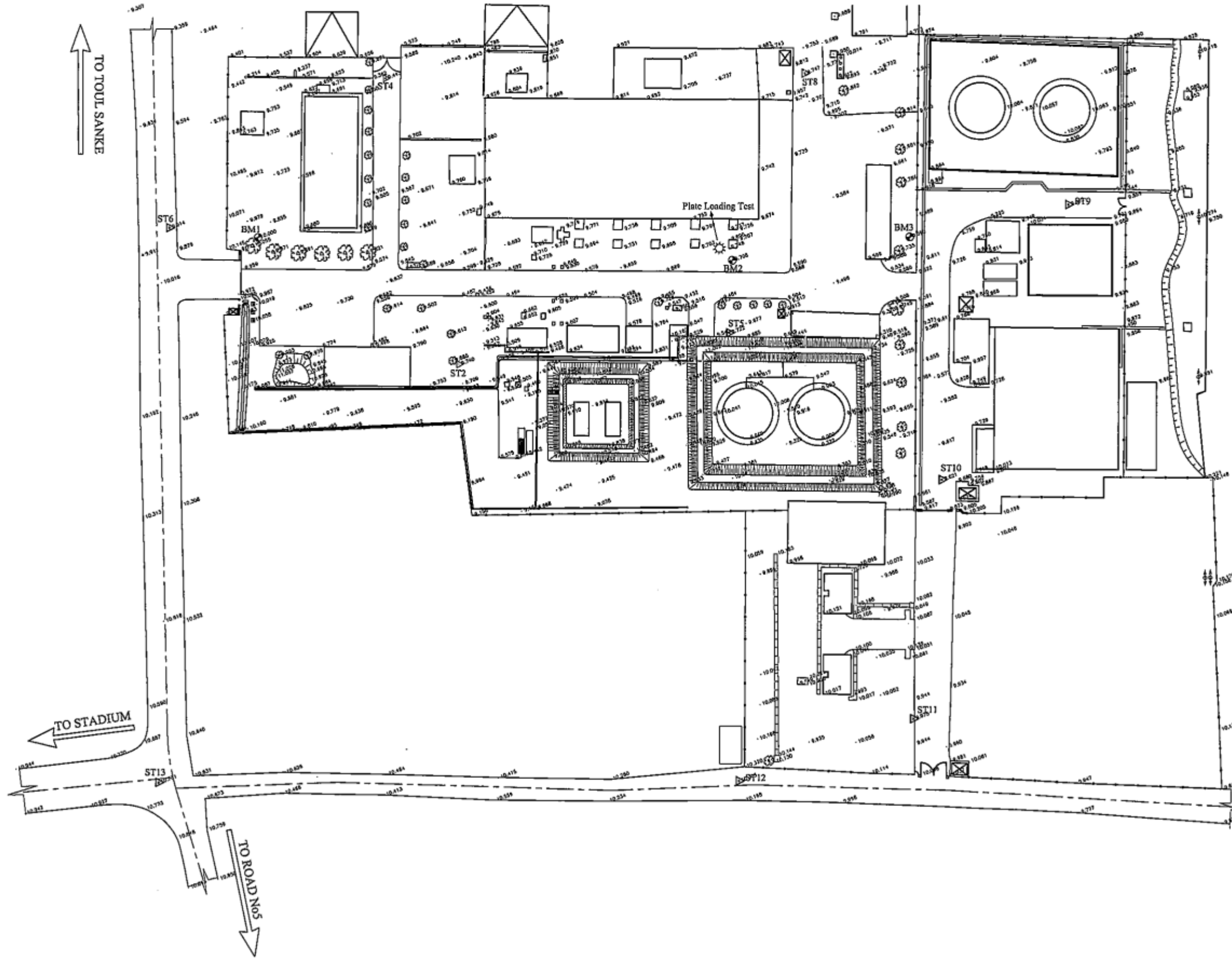

THE COORDINATE AND ELEVATION SYSTEM ASSUMED NOT TO ANY KNOWN GRID LINE.

JICA JICA Study Team Project Office
 YACHIYO ENGINEERING CO.,LTD.
 TOKYO, JAPAN

PROJECT TITLE: THE PROJECT FOR CONSTRUCTION AND IMPROVEMENT OF THE DIESEL ENGINE GENERATORS OF EDC C5 POWER PLANT IN PHNOM PENH OF THE KINGDOM OF CAMBODIA					
DRAWING TITLE: Topographical Site Plan of Power Station(C5)					Date: April-2004
Drawn by:	Checked by:	Approved by:	File:	Scale: 1/1000	Sheet: A12-1

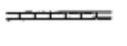
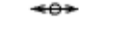
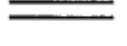

LEGEND

-  FUEL TANK
-  SECURITY POST
-  CONCRETE BLOCK OR BUILDING
-  BENCH-MARK (BM)
-  STATION (STN)
-  TREE
-  BARBED WIRE FENCE
-  CABLE LINE
-  ELECTRIC POLE
-  U-DRAIN

COORDINATE POINTS

POINT No	N(m)	E(m)	Z(m)
BM1	500.000	500.000	10.000
BM2	611.040	505.265	9.708
BM3	652.762	499.690	9.990
STN2	547.104	529.834	9.740
STN4	529.848	462.778	9.443
STN5	610.348	522.365	9.722
STN6	479.318	497.736	9.914
STN8	628.077	461.419	9.747
STN9	690.044	492.204	9.662
STN10	660.330	556.843	9.621
STN11	653.791	613.100	9.975
STN12	612.826	627.737	10.305
STN13	477.213	628.314	10.731

NOTE:

THE COORDINATE AND ELEVATION SYSTEM ASSUMED NOT TO ANY KNOWN GRID LINE.

JICA JICA Study Team Project Office
 YACHIYO ENGINEERING CO.,LTD.
 TOKYO . JAPAN

PROJECT TITLE: THE PROJECT FOR CONSTRUCTION AND IMPROVEMENT OF THE DIESEL ENGINE GENERATORS OF EDC CS POWER PLANT IN PHNOM PENH IN THE KINGDOM OF CAMBODIA

DRAWING TITLE: Topographical Survey Plan of Power Station(CS) Date: April-2004

Drawn by:	Checked by:	Approved by:	File:	Scale:	Sheet:
				1/1000	A12-2