

Appendix 9. Basic Design Drawings

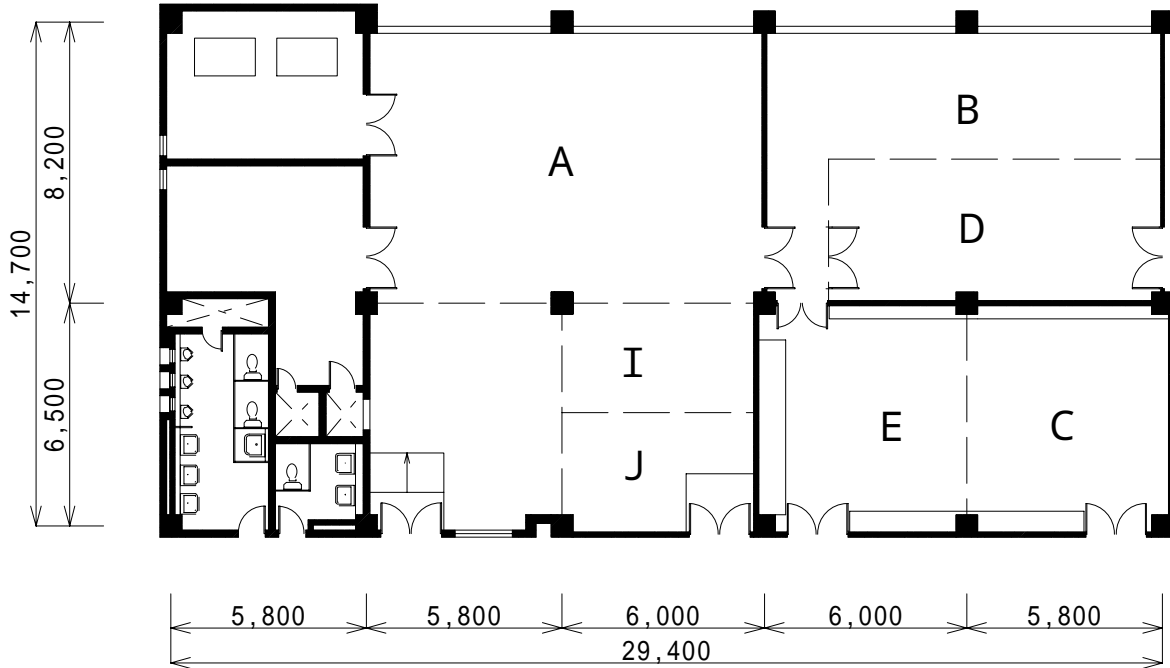

Area	Equipment	Quantity
A	Electrical Calibration System	1 set
B	Temperature Calibration System	1 set
C	Length Calibration System	1 set
D	Mass Calibration System	1 set
E	Pressure Calibration System	1 set
I	Speed Calibration System *	-
J	Light Calibration System	1 set

*: No planning equipment

Electronic Services and Training Center - First Floor

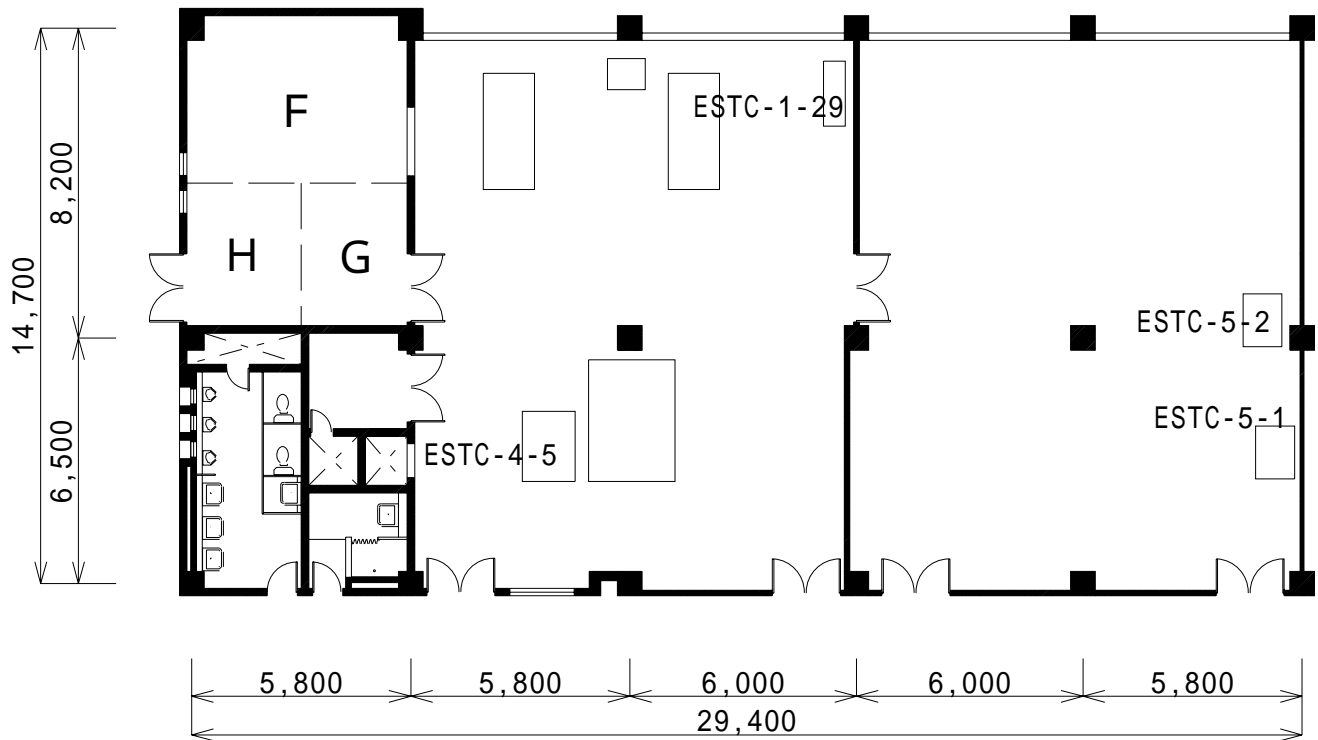

Area	Equipment	Quantity
F	Force Calibration System	1 set
G	Volume & Density Calibration System	1 set
H	Flow Calibration System	1 set

Area	Equipment	Quantity
	Equipment needed for testing safety of Home Use Electronic Appliance	1 set
	Equipment needed for testing of Electric Irons	1 set
	Equipment needed for testing of Switches, Plugs and Sockets	1 set
	Equipment needed for testing of Refrigerators, Freezers, and Bottle Coolers	1 set
	Equipment needed for testing of Lead Acid Starter Batteries	1 set
	Equipment needed for testing of Television Receivers	1 set
	Equipment needed for testing of Circuit Breakers	1 set

No.	Equipment	Quantity
ESTC-1-29	Test corner	1 unit
ESTC-4-5	Temperature and Humidity Chamber	1 unit
ESTC-5-1	Temperature Chamber	1 unit
ESTC-5-2	Vibration Tester	1 unit

Electronic Services and Training Center - Grand Floor

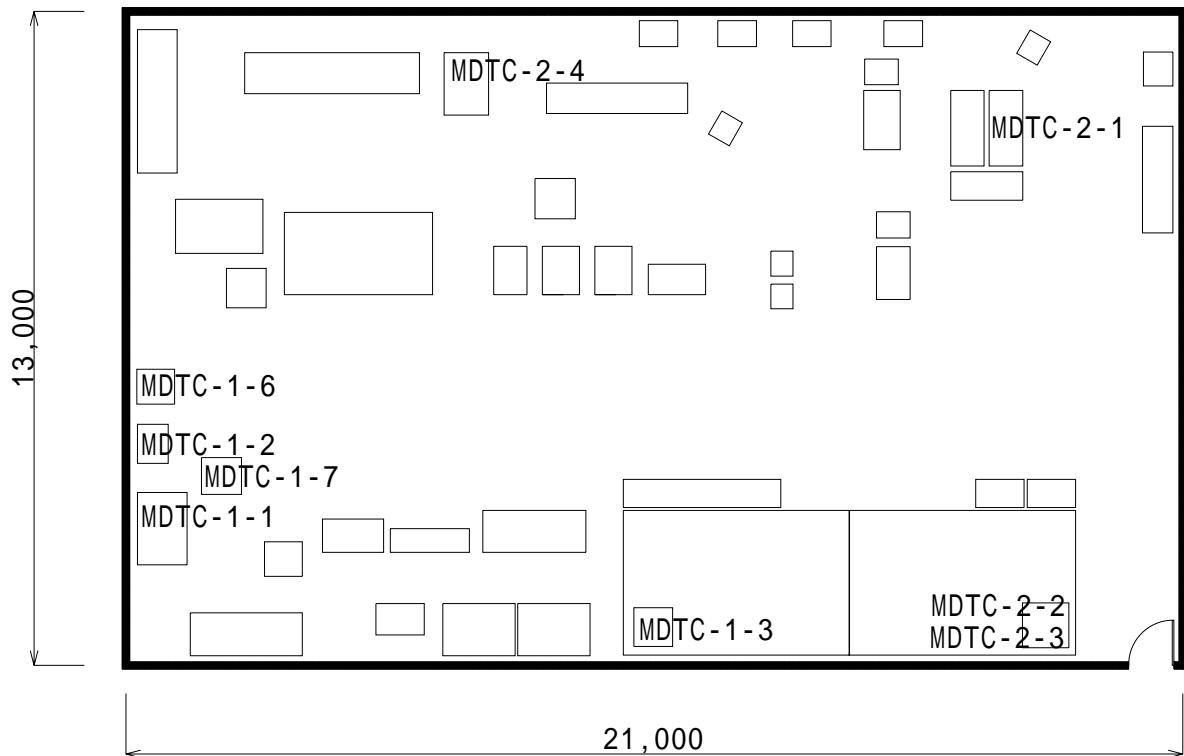

No.	Equipment	Quantity
MDTC-1-1	Universal testing machine	1 unit
MDTC-1-2	Melt flow indexer	1 unit
MDTC-1-3	Analytical balance	1 unit
MDTC-1-6	Computerized tensile film tester	1 unit
MDTC-1-7	Sample preparation machine	1 unit
MDTC-1-9	Punch dies for plastic tensile samples	3 pcs
MDTC-2-1	Automated Universal tensile/compression testing machine	1 unit
MDTC-2-2	Analytical balance	1 unit
MDTC-2-3	Thermocouple	1 unit
MDTC-2-4	Impact testing machine	1 unit

Mechanical Design and Technology Center - Plastics & Rubber Unit, Strength of Materials Unit

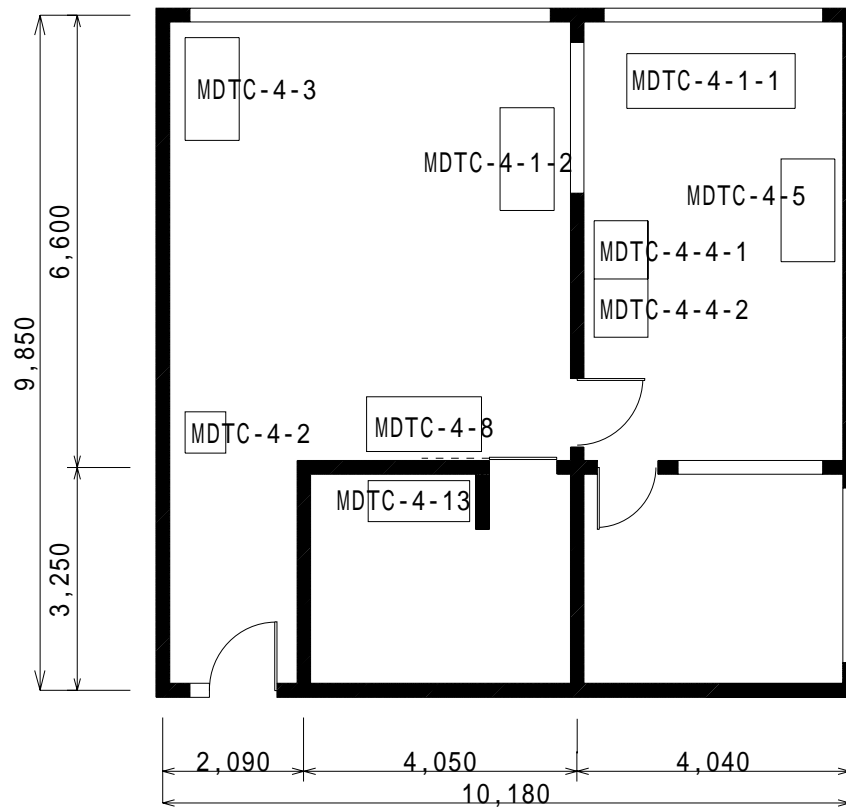

No.	Equipment	Quantity
MDTC-4-1-1	Scanning Electron Microscope	1 unit
MDTC-4-1-2	CS Analyzer	1 unit
MDTC-4-2	Cutting Machine	1 unit
MDTC-4-3	Grinding and polishing machines	1 set
MDTC-4-4-1	Digital Universal Hardness Tester (Brinel, Vickers, and Rockwell)	1 unit
MDTC-4-4-2	Mini-load hardness (Micro-hardness) tester (Vickers)	1 unit
MDTC-4-5	Portable Spectrometer	1 unit
MDTC-4-7	Universal Hardness Tester References Blocks	1 pc
MDTC-4-8	Electronic Balance	1 unit
MDTC-4-13	Automatic Mounting Press Machine for Sample preparation	1 unit
MDTC-4-14	Lacquer thickness measurement	1 unit

Mechanical Design and Technology Center - Metallography Laboratory

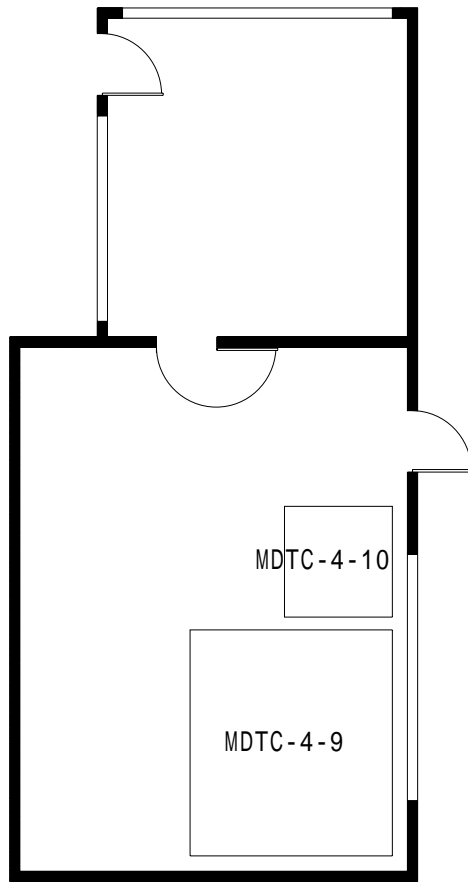

No.	Equipment	Quantity
MDTC-4-9	Electric Furnace	1 unit
MDTC-4-10	Salt Spray cabinet	1 unit

Mechanical Design and Technology Center - Heat Treatment Laboratory

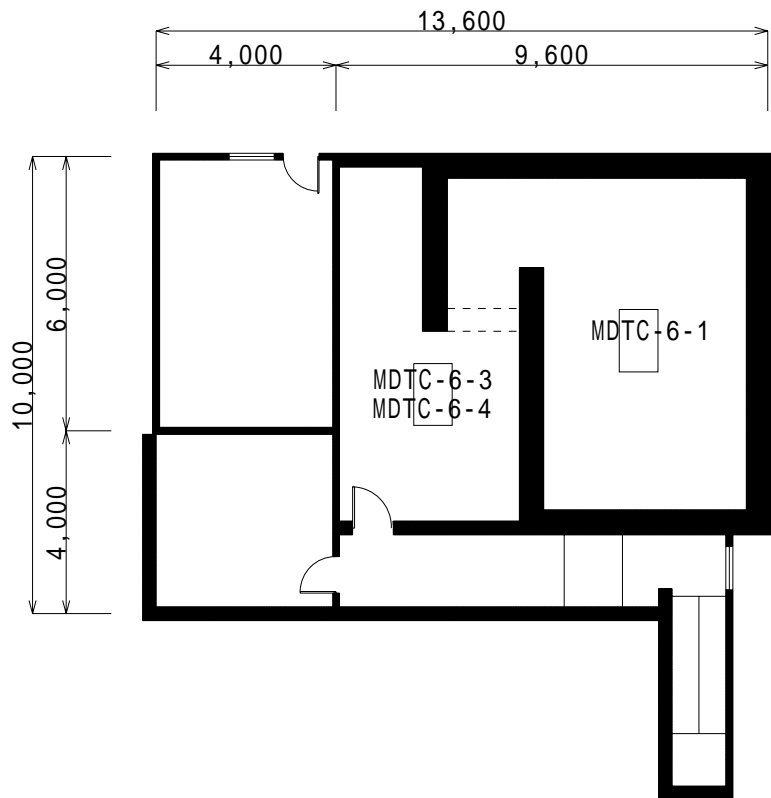

No.	Equipment	Quantity
MDTC-6-1	Directional X-Ray Machine for Industrial Radiography	1 unit
MDTC-6-3	Digital Ultrasonic Flow Setector	1 unit
MDTC-6-4	Digital Ultrasonic Thickness Gauges	1 unit

Mechanical Design and Technology Center - Non-Destructive Testing Unit

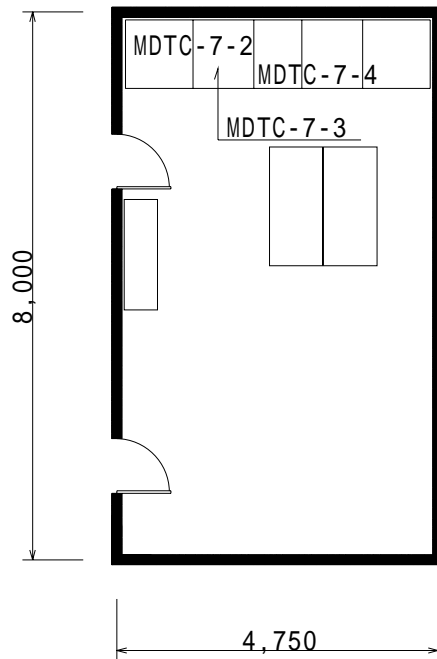

No.	Equipment	Quantity
MDTC-7-2	Gamma – Ray Spectroscopy Analysis Software	1 set
MDTC-7-3	Portable Gamma Spectroscopy System	1 unit
MDTC-7-4	Radon / Radon Daughter Detector	1 unit

Mechanical Design and Technology Center -
Radiation Measurement and Calibration Laboratory

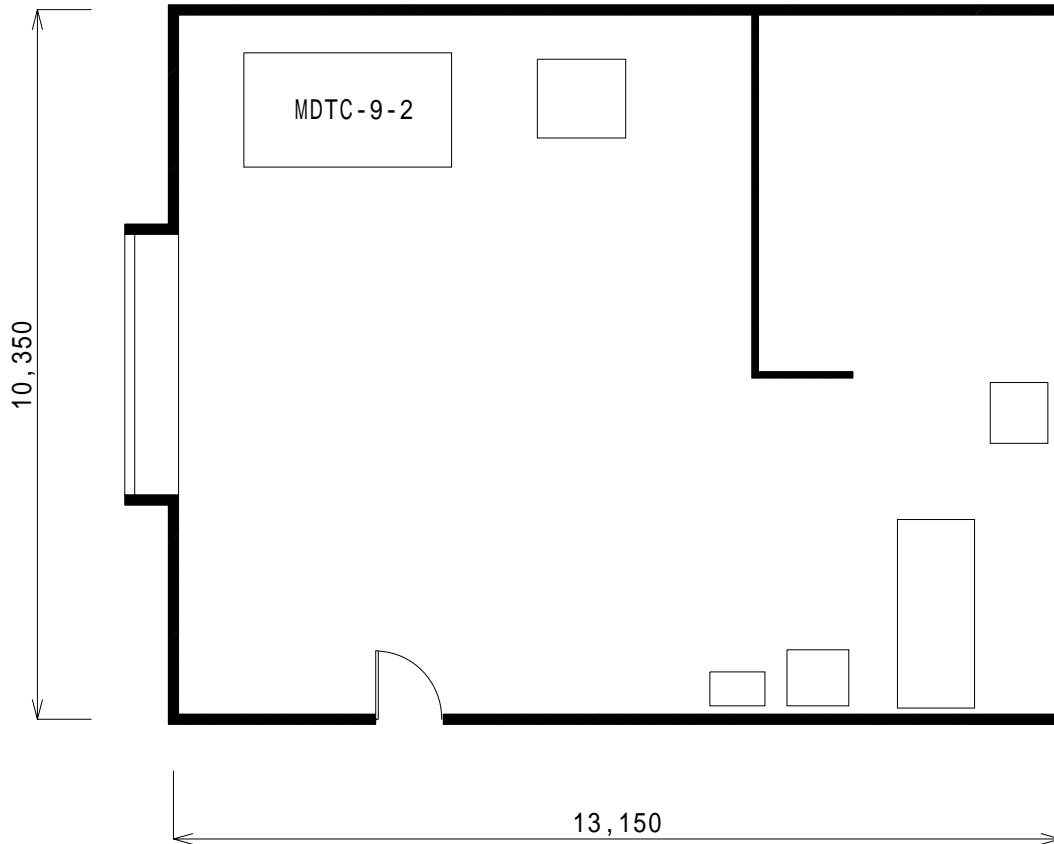

No.	Equipment	Quantity
MDTC-9-1	Portable Hardness Tester	1 unit
MDTC-9-2	Induction Furnace	1 set

Mechanical Design and Technology Center - Casting Technology Unit

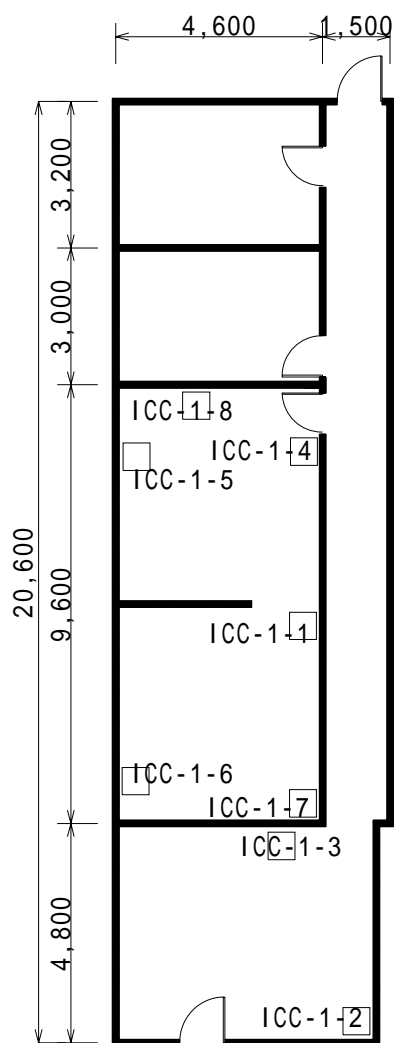

No.	Equipment	Quantity
ICC-1-1	Nu-Martindale Tester	1 unit
ICC-1-2	Washing Machine	1 unit
ICC-1-3	Steaming Cylinder with Steam Generator	1 unit
ICC-1-4	Air Permeability of Paper	1 unit
ICC-1-5	Driven Precision Yarn Reel Instrument	1 unit
ICC-1-6	Motor Driven Water Penetration Tester	1 unit
ICC-1-7	Reflectometer	1 unit
ICC-1-8	Tensile Machine	1 unit

Industrial Chemistry Center - Textile & Paper Unit

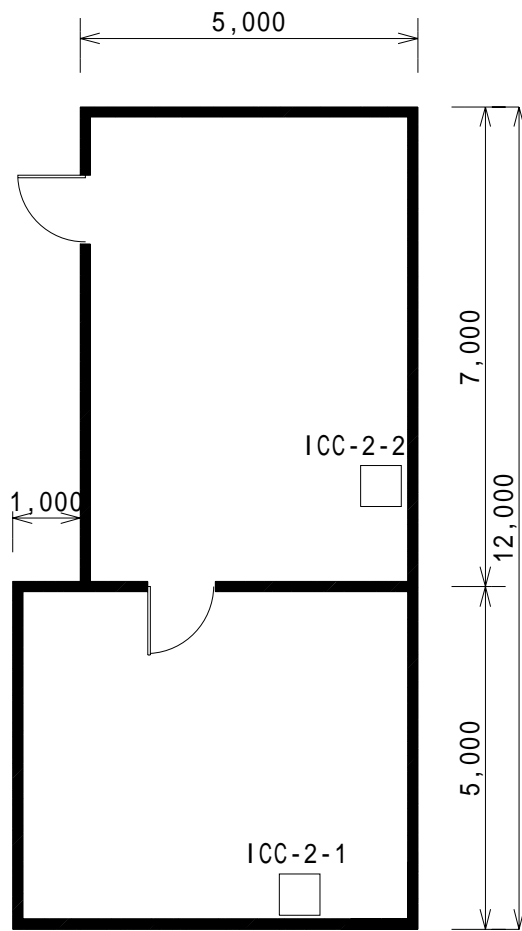

No.	Equipment	Quantity
ICC-2-1	Smoking Machine	1 unit
ICC-2-2	Gas Chromatograph	1 unit

Industrial Chemistry Center - Cigarettes Unit

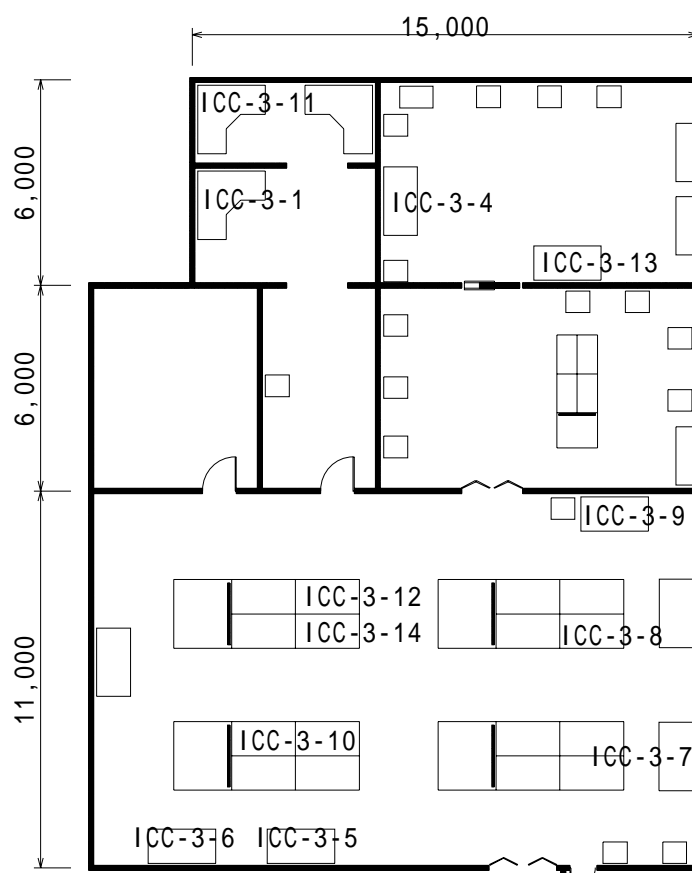

No.	Equipment	Quantity
ICC-3-1	Gas Chromatography/Mass Spectrometer (GC/MS)	1 unit
ICC-3-4	Automatic Kjeldahl Nitrogen Analyzer	1 unit
ICC-3-5	Milk Analyzer	1 unit
ICC-3-6	Meat Analyzer	1 unit
ICC-3-7	Polarimeter	1 unit
ICC-3-8	Titration Apparatus	1 unit
ICC-3-9	Amino Acid Analyzer	1 unit
ICC-3-10	Automatic Melting Point Apparatus	1 unit
ICC-3-11	Moisture Meter	1 unit
ICC-3-12	Density meter	1 unit
ICC-3-13	Muffle Furnace	1 unit
ICC-3-14	pH/Ion Meter	1 unit

Industrial Chemistry Center - Organic & Food Unit 1

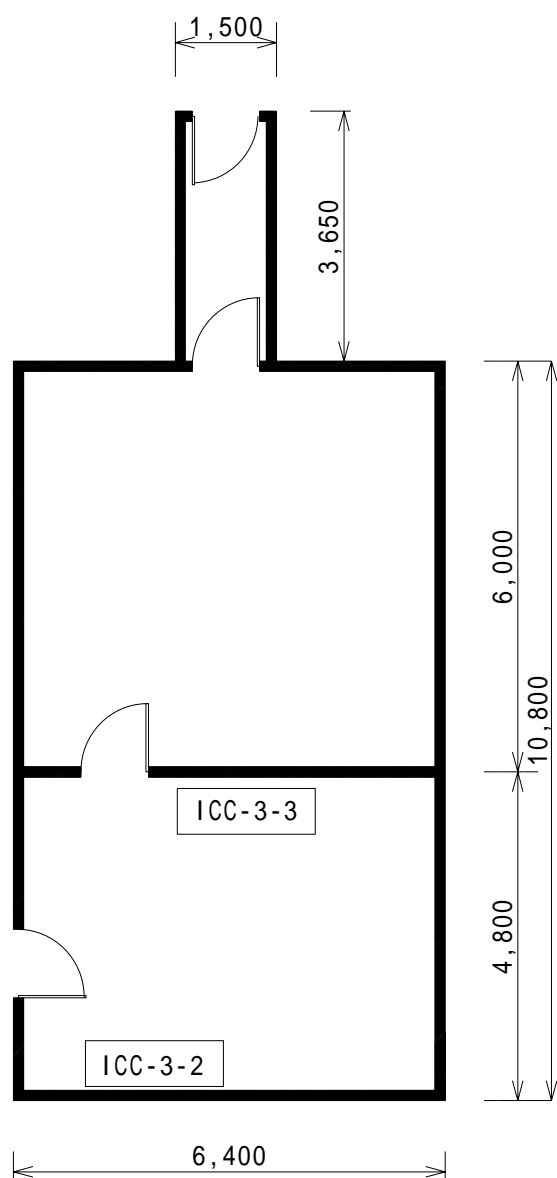

No.	Equipment	Quantity
ICC-3-2	Gas Chromatography/Flame Ionization (GC/FID)	1 unit
ICC-3-3	High Performance Liquid Chromatography (HPLC) (Semi-Preparative)	1 unit

Industrial Chemistry Center - Organic & Food Unit 2

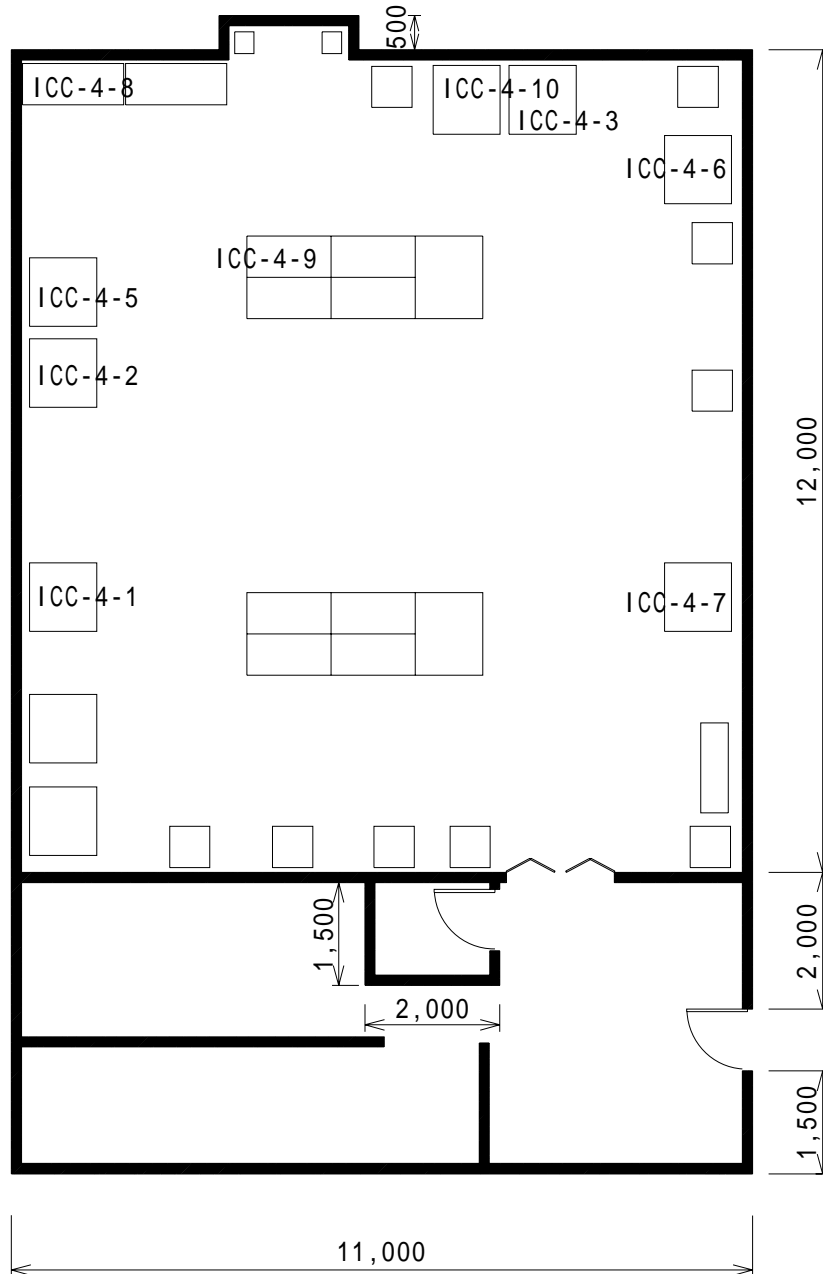

No.	Equipment	Quantity
ICC-4-1	Lubricant Test Machine	1 unit
ICC-4-2	Dielectric Breakdown Voltage of Insulating Liquids	1 unit
ICC-4-3	Evaporating Loss of Lubricating Oils (Noack Test)	1 unit
ICC-4-5	Determination of Vapor pressure	1 unit
ICC-4-6	Determination of Air Release Value	1 unit
ICC-4-7	Demulsibility Characteristics	1 unit
ICC-4-8	Rapid Flash point Tester	1 unit
ICC-4-9	Automatic Oxygen Bomb Calorimeter	1 unit
ICC-4-10	Bench top XRF	1 unit

Industrial Chemistry Center - Petrol & Lubricants Laboratory

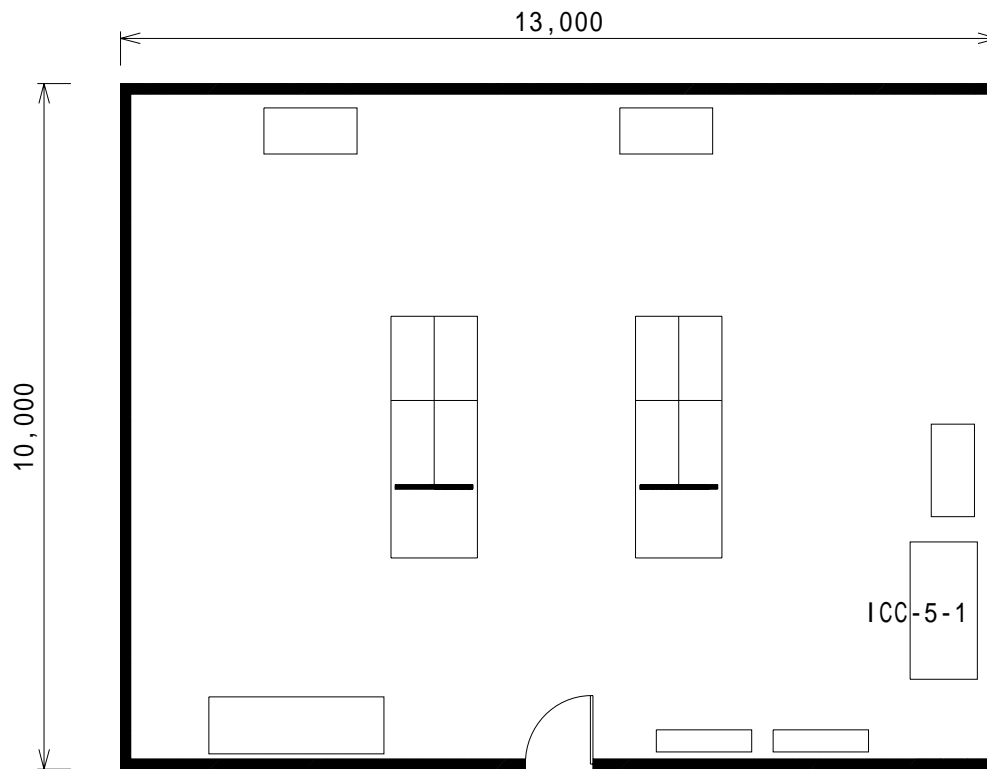

No.	Equipment	Quantity
ICC-5-1	Constant Climate Chamber	1 unit

Industrial Chemistry Center - Paints, Lacquers & Solvents Laboratory 1

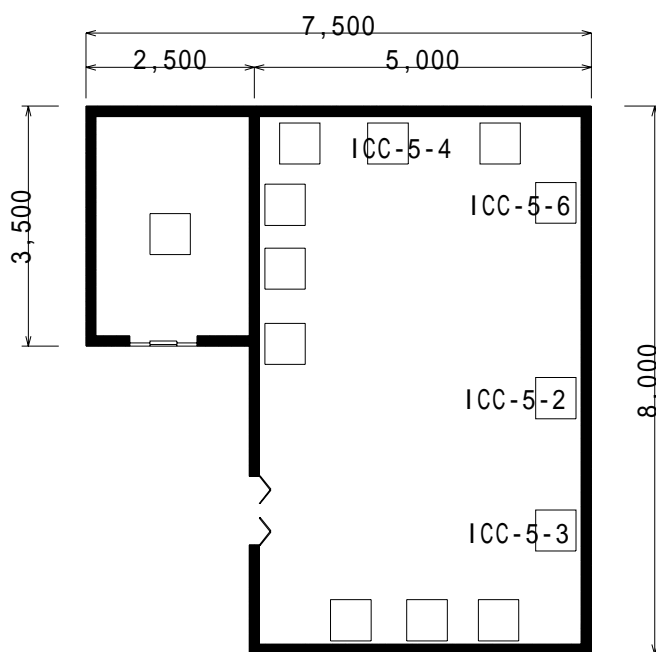

No.	Equipment	Quantity
ICC-5-2	Cone and Plate Viscometer	1 unit
ICC-5-3	Digital Constant Temperature Bath/ circulator & cooler	1 unit
ICC-5-4	Drying Time Recorder & Film Applicator	1 unit
ICC-5-6	Superchroma Spectrocolori Meter	1 unit

Industrial Chemistry Center - Paints, Lacquers & Solvents Laboratory 2

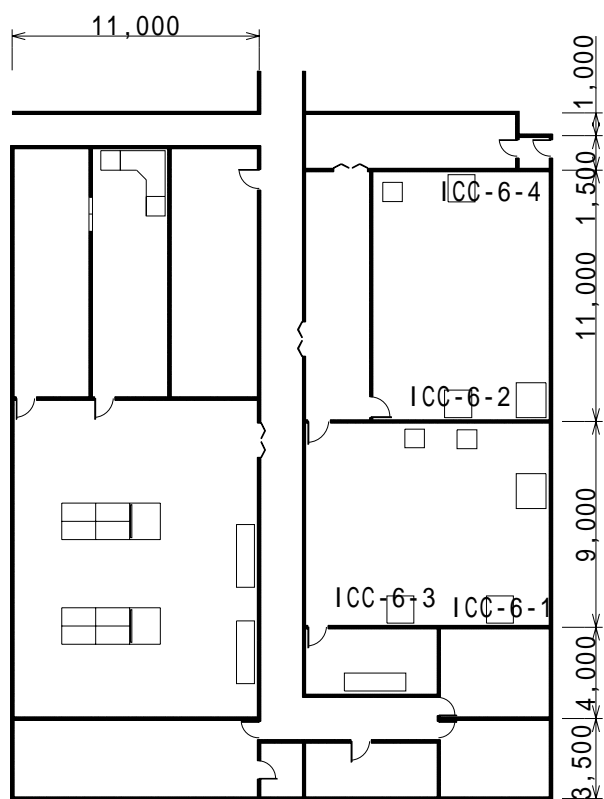

No.	Equipment	Quantity
ICC-6-1	Atomic Absorption Spectrophotometer	1 unit
ICC-6-2	XRD – (X-Ray Diffractometer)	1 unit
ICC-6-3	Sequential Plasma Emission Spectrometer (ICP)	1 unit
ICC-6-4	XRF- Sequential Spectrometer	1 unit

Industrial Chemistry Center - Inorganic Material Division

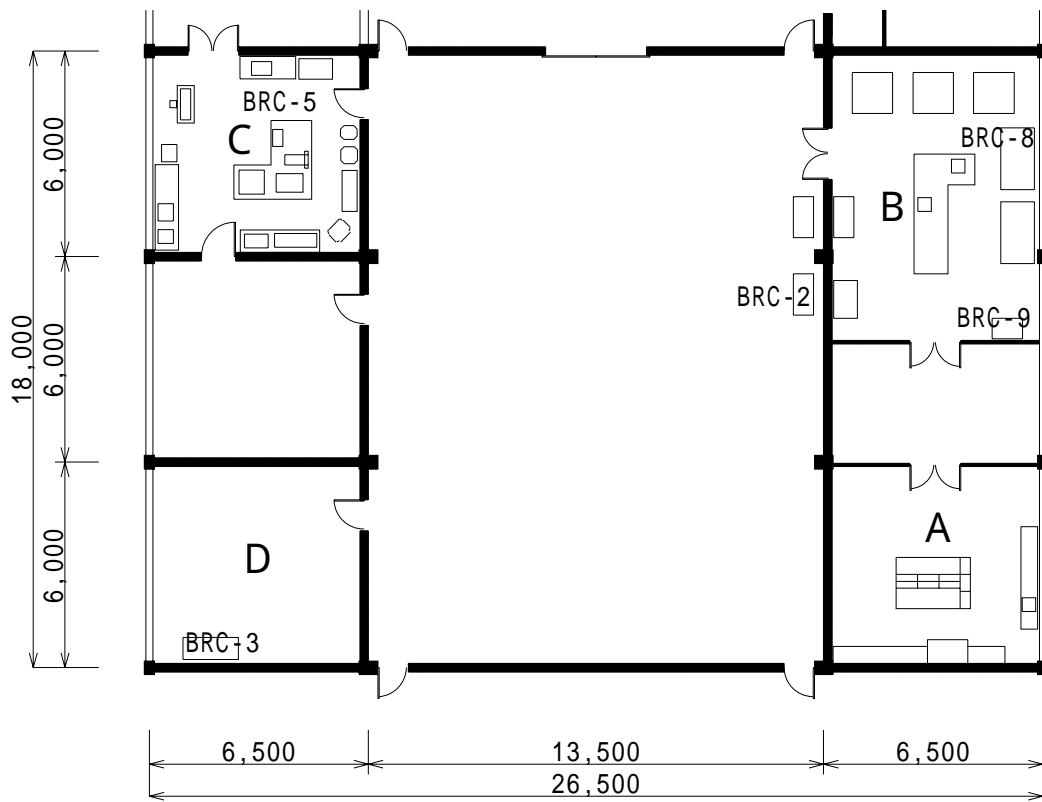

Area	Laboratory/Unit
A	Cement Laboratory
B	Concrete Laboratory
C	Ceramics Unit
D	Building Components & Insulation Materials Unit

No.	Equipment	Quantity
BRC-2	Auto Test Compression/Flexural Machine	1 unit
BRC-3	Guarded Hot Plate Apparatus	1 unit
BRC-5	Equipment and accessories to test Sanitary Ware	1 unit
BRC-8	Non-Destructive Ultrasonic Testing Device	1 unit
BRC-9	Water Permeability of Concrete	1 unit

Building Research Center

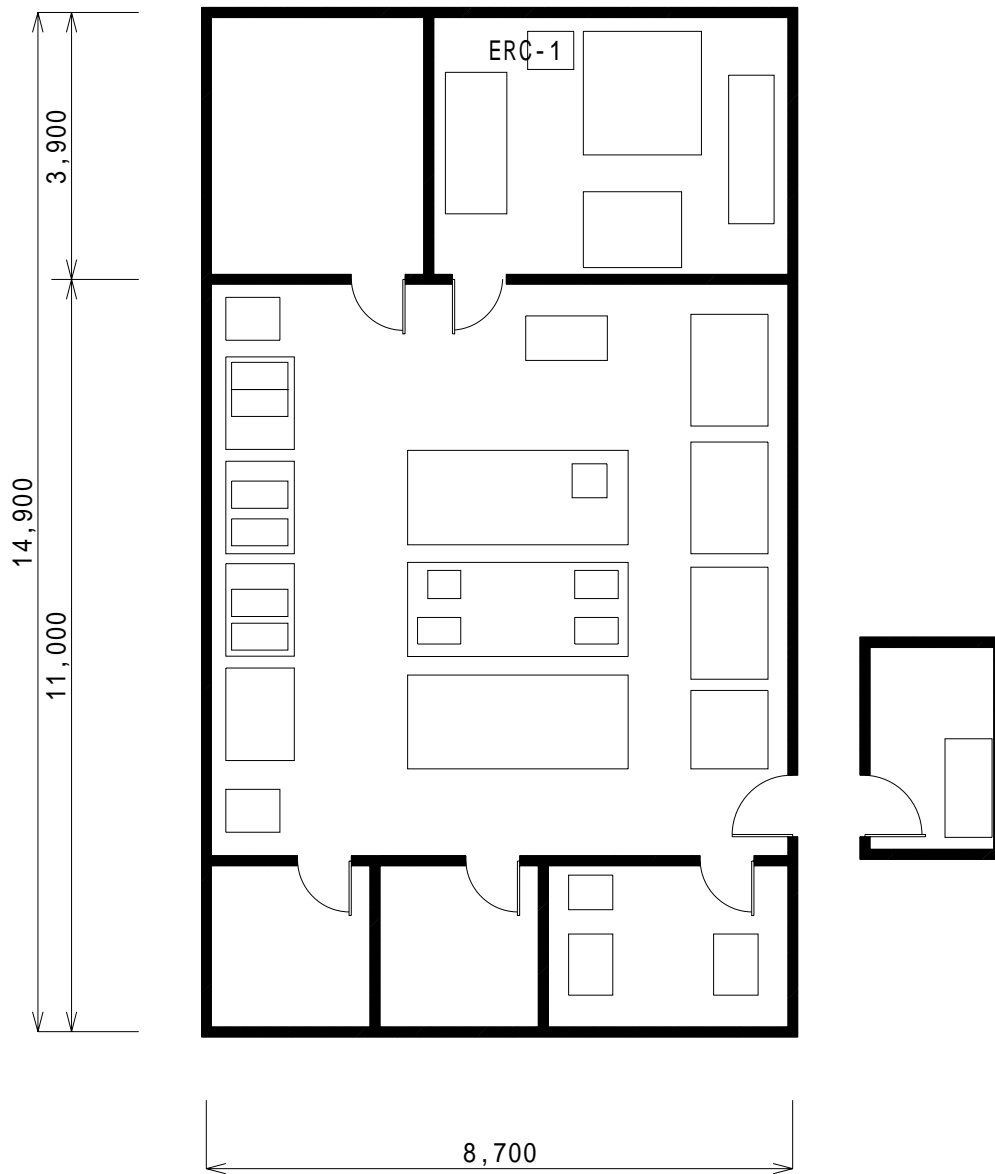

No.	Equipment	Quantity
ERC-1	Multi Stage Cyanide Distillation System	1 unit

Environmental Research Center - Chemical Analysis Laboratory

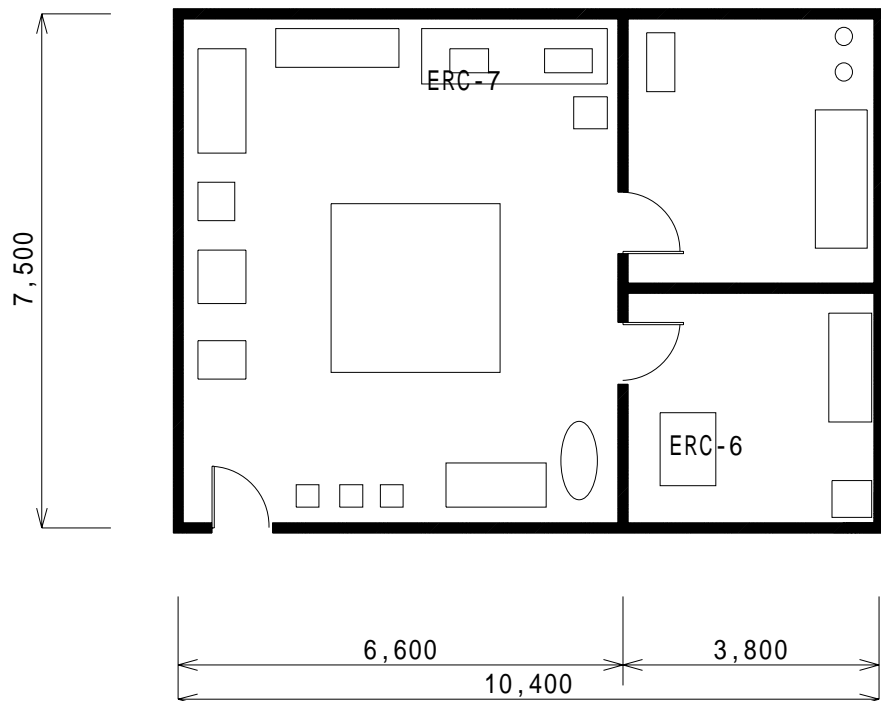

No.	Equipment	Quantity
ERC-6	Gas Chromatograph/ Electron Capture Detector (GC/ECD)	1 unit
ERC-7	Rotary Evaporator System	1 unit

Environmental Research Center - Environment & Organic Analysis Laboratory

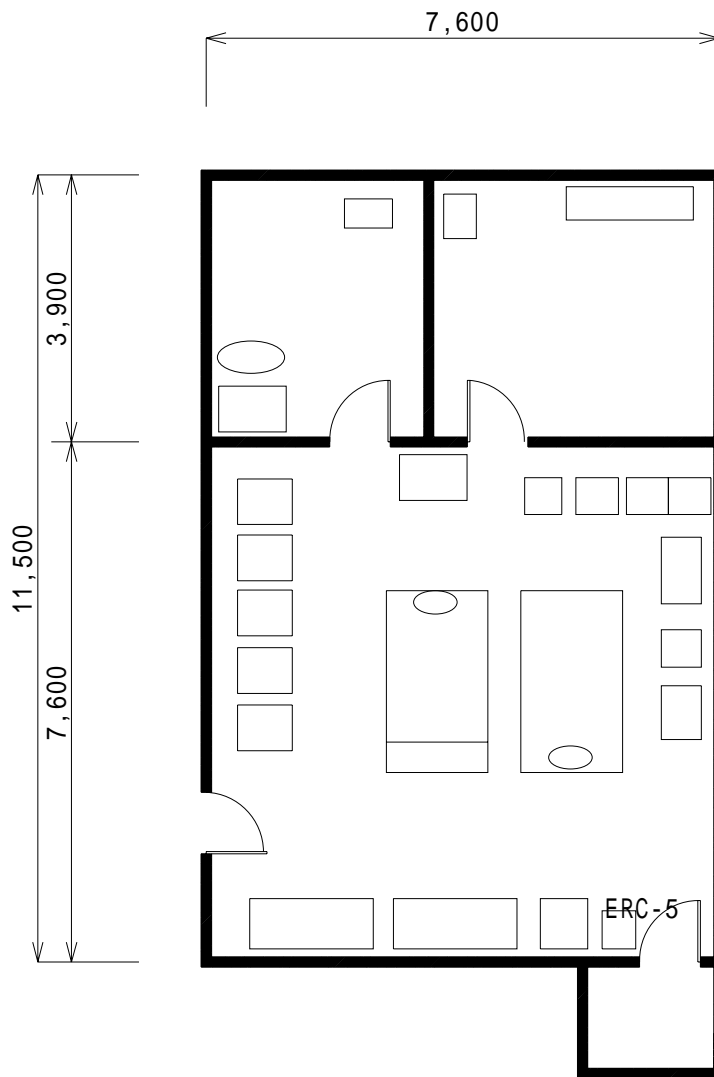

No.	Equipment	Quantity
ERC-5	Environmental Cabinet Assembly	1 unit

Environmental Research Center - Microbiological Testing Unit