

ANNEX. II

FORMATS OF DAMAGE CONDITIONS

BAY NO. 65

FORMATS OF DAMAGE CONDITIONS-BAY NO. - 65

Table of Contents

- 1) Index Plan showing damage points in Bay No. - 65**
- 2) Point No. 1 - Boiling of water taking place from underneath the floor.**
- 3) Point No. 2 - Ripping up/erosion of skin concrete (which is not monolithic with the underlying mass concrete) adjacent to the impact block.**
- 4) Point No. 3 - Ripping up/erosion of skin concrete (which is not monolithic with the underlying mass concrete) adjacent to the impact block.**
- 5) Point No. 4 - Ripping up/erosion of skin concrete (which is not monolithic with the underlying mass concrete) adjacent to the impact block.**
- 6) Point No. 5 - Boiling point at the downstream floor of Bay No. 65**
- 7) Point No. 6 - Depressed area below the existing downstream floor level.**

Index Plan Showing Damage Points In

Bay No. 65 From Left
(Sketch)

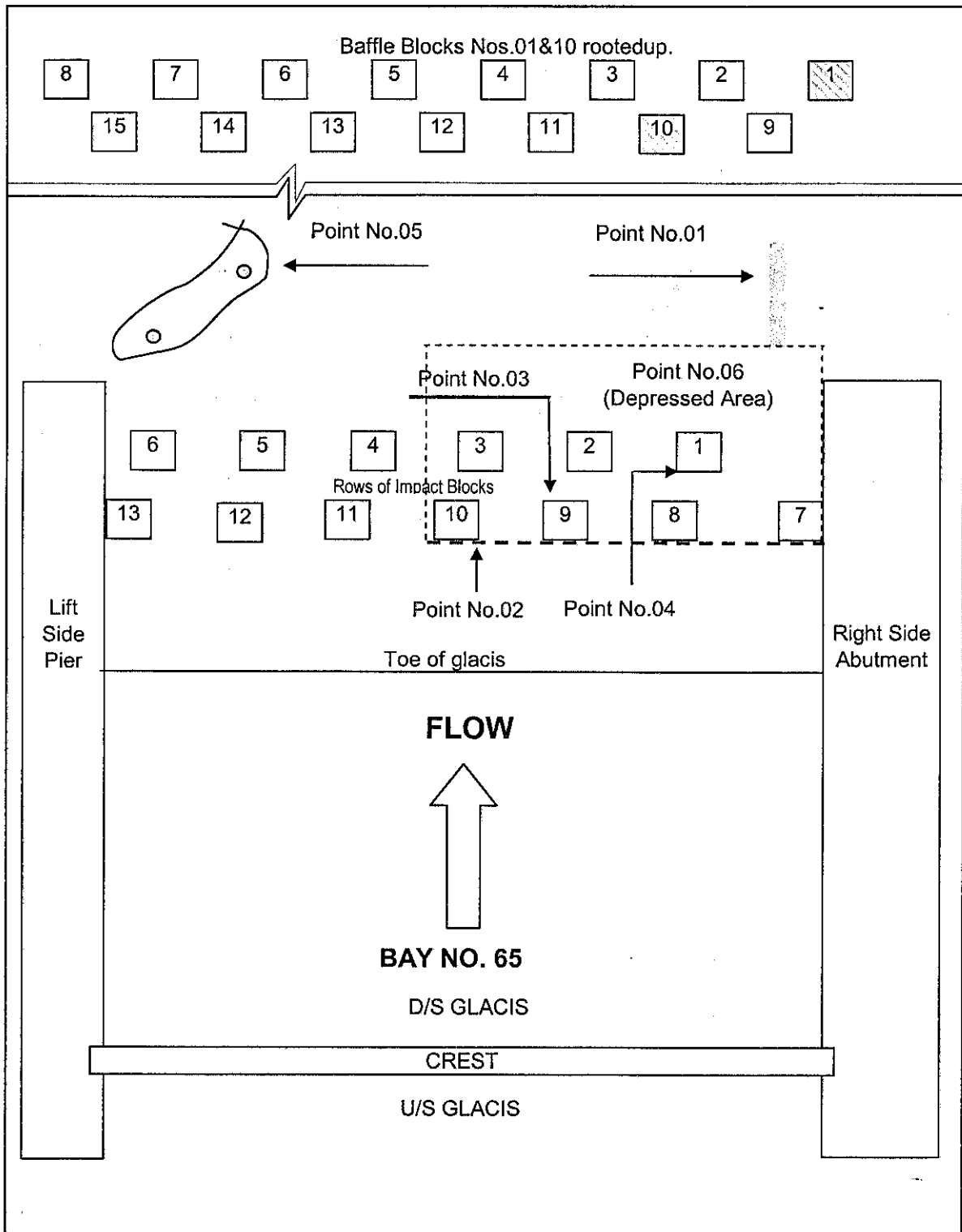

Report of damage conditions.

Ref No: Point No. 01	Survey date: 14-01-2004
<p>Location.</p> <p>D/S of 65th Gate/Bay from left side. (Position diagram).</p> <p>Given below.</p>	<p>Outline of damage.</p> <p>Boiling of water taking place from underneath the floor at the location shown below.</p>

Outline drawings.

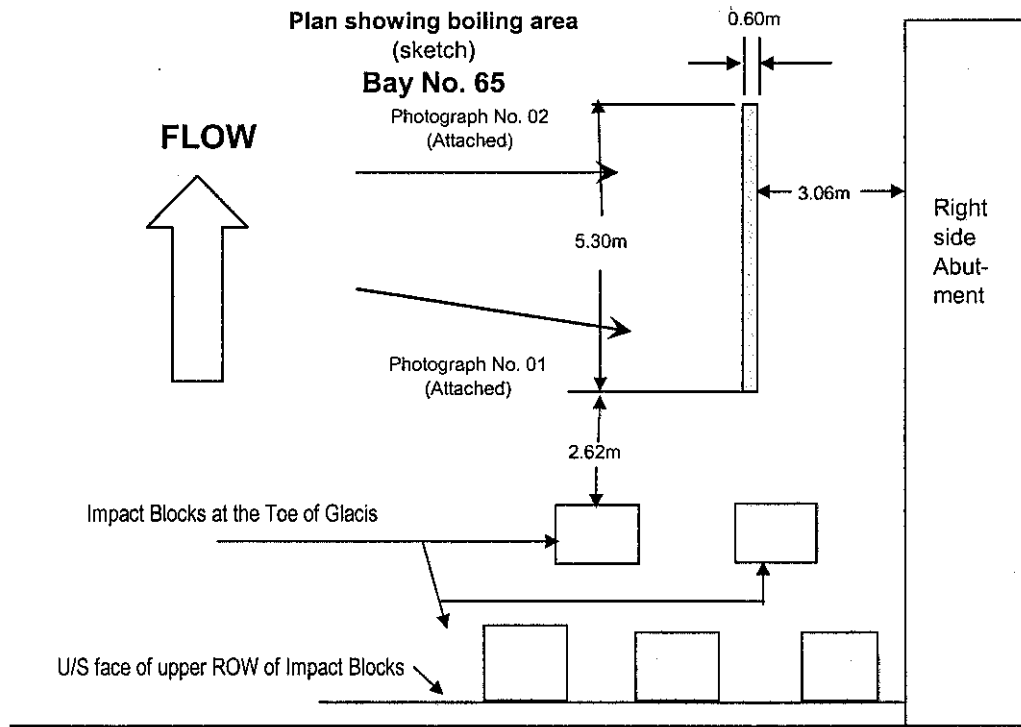

Note: Arrows shown for photographs indicate the angle at which the photographs were taken at site.

149

Bay No. 65

Boiling of water taking place from underneath the floor.



Photograph No. 01



Photograph No. 02

Report of damage conditions.

Ref No: Point No.02	Survey date: 14-01-2004
Location. D/S of 65th Gate/Bay from left side. (Position diagram). Given below.	Outline of damage. Ripping up/erosion of skin concrete (which is not monolithic with the underlying mass concrete) adjacent to the impact block- at the location shown below.

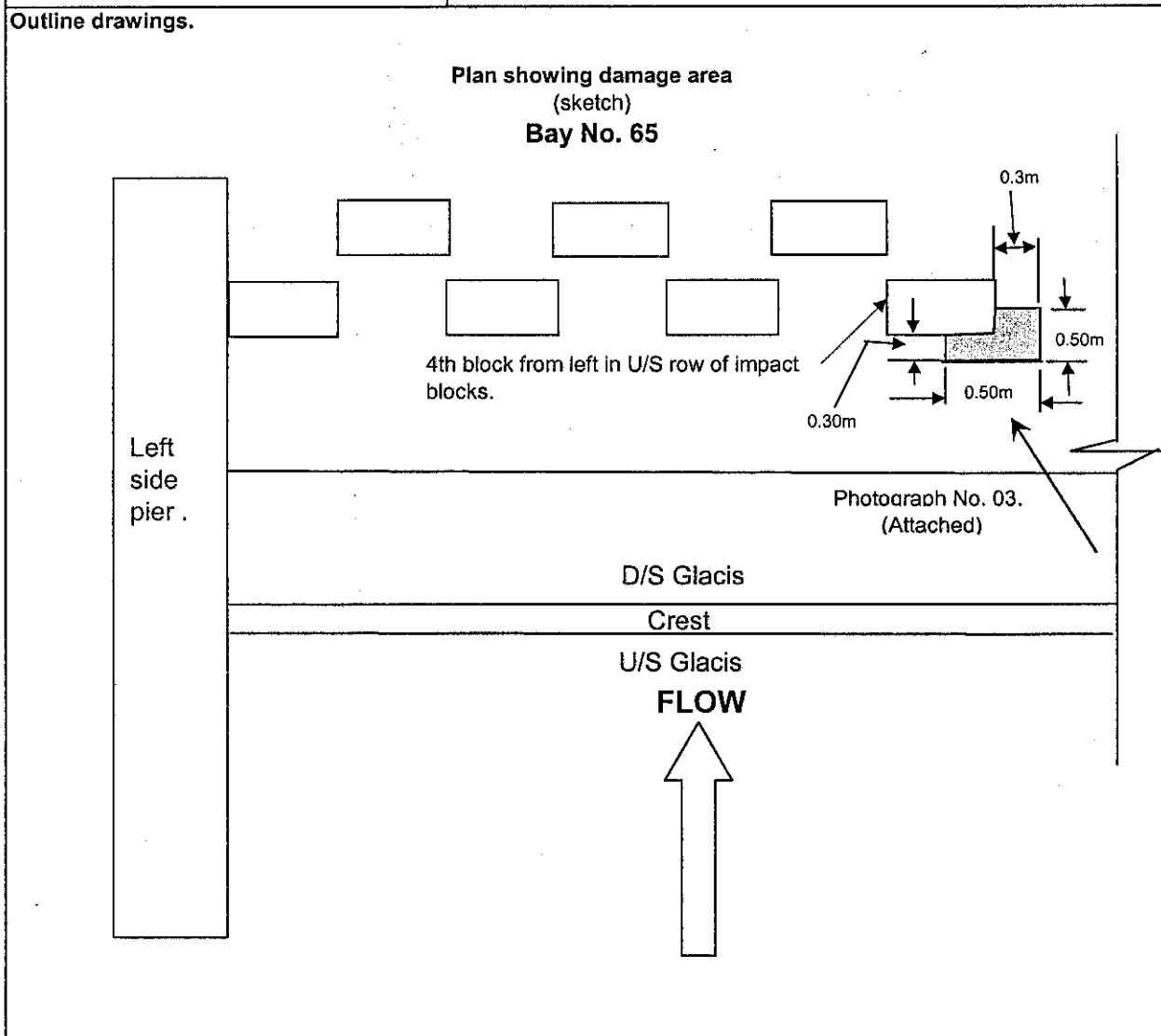

Note: Arrows shown for photographs indicate the angle at which the photographs were taken at site.

15/1

Bay No. 65

Rippingup/erosion of skin concrete adjacent to the impact block.



Photograph No. 03

Report of damage conditions.

Ref No; Point No.03	Survey date: 14-01-2004
Location. D/S of 65th Gate/Bay from left side. (Position diagram). Given below.	Outline of damage. Ripping up/erosion of skin concrete (which is not monolithic with the underlying mass concrete) adjacent to the impact block- at the location shown below.

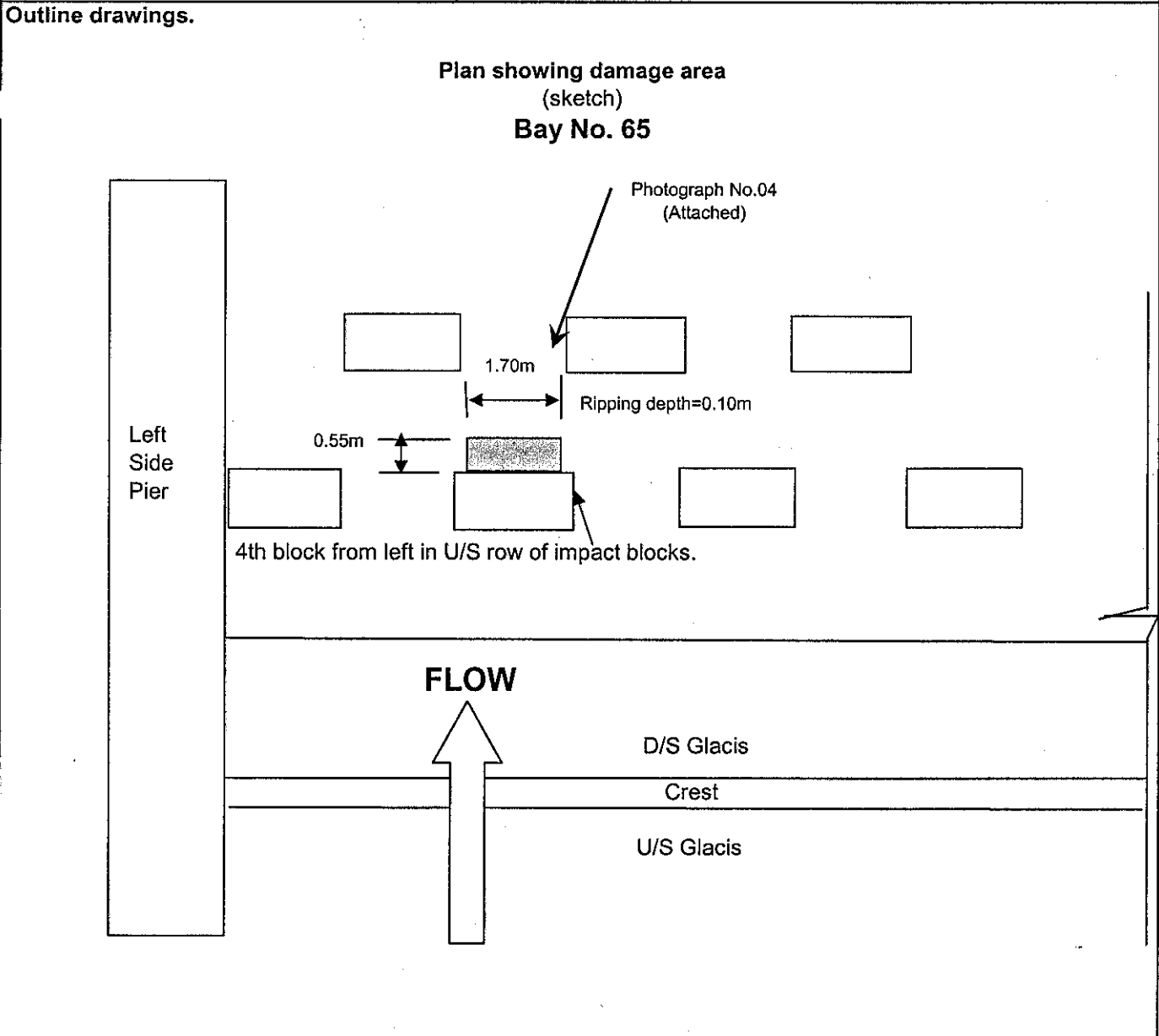

Note: Arrows shown for photographs indicate the angle at which the photographs were taken at site.

Bay No. 65

Rippingup/erosion of skin concrete adjacent to the impact block.



Photograph No. 04

Report of damage conditions.

Ref No; Point No.04	Survey date: 14-01-2004
<p>Location.</p> <p>D/S of 65th Gate/Bay from left side. (Position diagram).</p> <p>Given below.</p>	<p>Outline of damage.</p> <p>Ripping up/erosion of skin concrete (which is not monolithic with the underlying mass concrete) adjacent to the impact block- at the location shown below.</p>

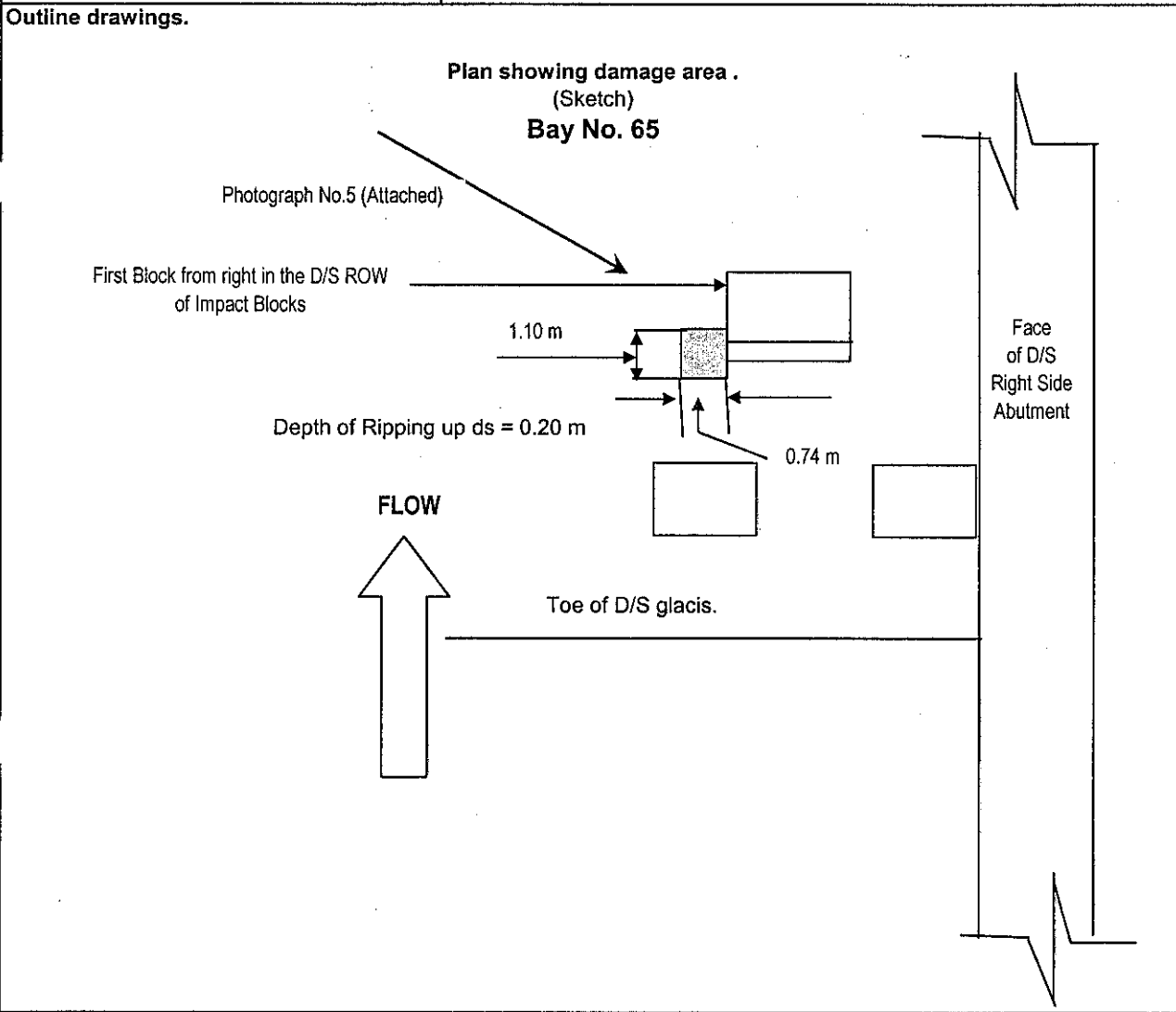

Note: Arrows shown for photographs indicate the angle at which the photograph were taken at site.

155

Bay No. 65

Rippingup/erosion of skin concrete adjacent to the impact block.



Photograph No. 05

Report of damage conditions.

Ref No; Point No.05	Survey date: 14-01-2004
Location. D/S of 65th Gate/Bay from left side. (Position diagram). Given below.	Outline of damage. Boiling points at D/S of Bay No.65 from Left Side.

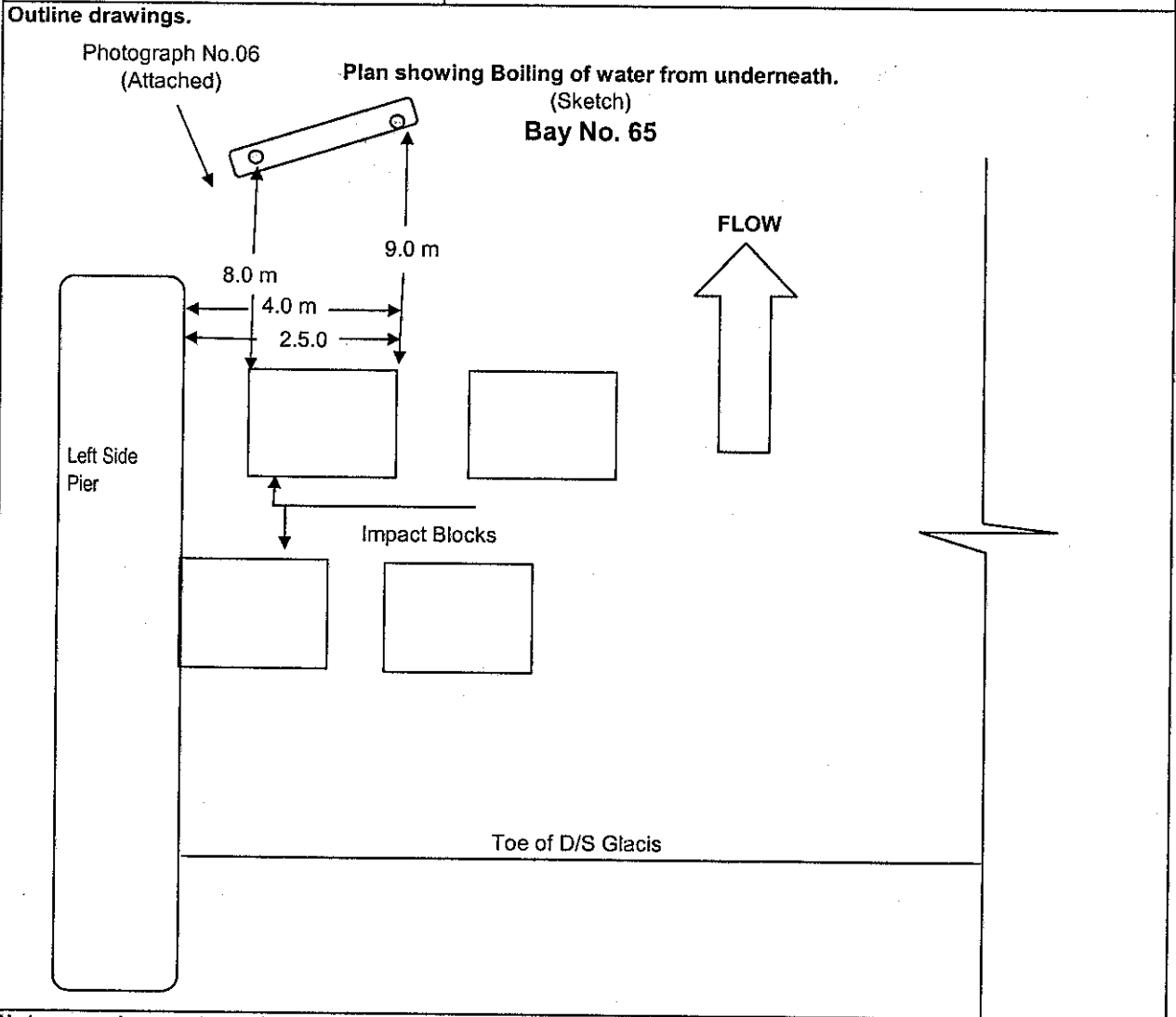

Note: Arrows shown for photographs indicate the angle at which the photograph were taken at site.

157

Bay No. 65

Spring/boiling points at D/S floor of the bay



Photograph No. 06

Report of damage conditions.

Ref No; Point No. 06	Survey date: 14-01-2004
Location. D/S of 65th Gate/Bay from left side. (Position diagram). Given below.	Outline of damage. Depressed Area below the existing D/S Floor Level.

Outline drawings.

Plan showing depressed area below the floor level.
(Sketch)
Bay No. 65

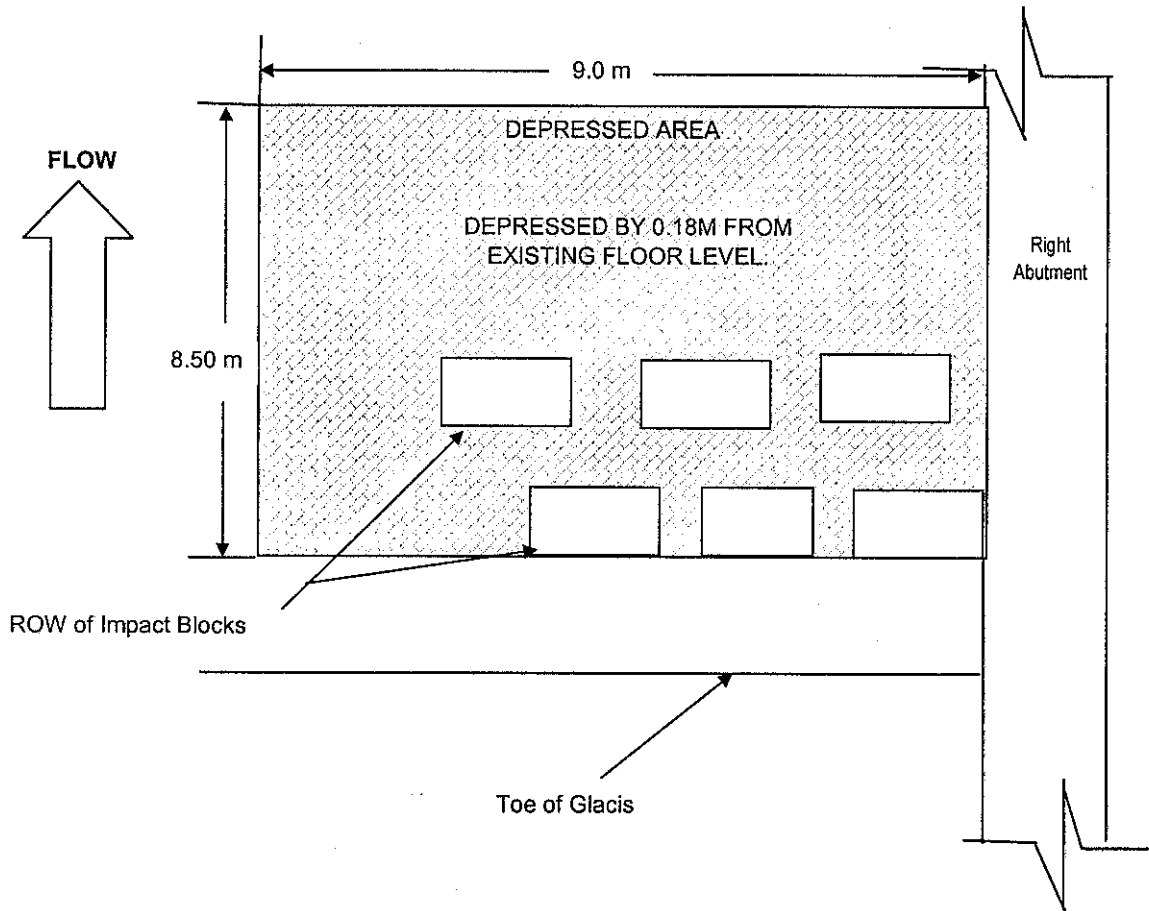

159

ANNEX. III

FORMATS OF DAMAGE CONDITIONS

BAY NO. 64

FORMATS OF DAMAGE CONDITIONS-BAY NO. - 64

Table of Contents

- 1) **Index Plan showing damage points in Bay No. - 64**
- 2) **Point No. 1 - Water leakage from the surface of downstream repaired glacis.**
- 3) **Point No. 2 - Water leakage from the surface of downstream repaired glacis.**
- 4) **Point No. 3 - Water leakage from the surface of downstream repaired glacis.**
- 5) **Point No. 4 - Water leakage from the surface of downstream repaired glacis.**
- 6) **Point No. 5 - Erosion of pier due to high velocity flow passing down below the gate.**
- 7) **Point No. 6 - Erosion of pier due to high velocity flow passing down below the gate.**

Index Plan Showing Damage Points In

Bay No. 64 From Left

(Sketch)

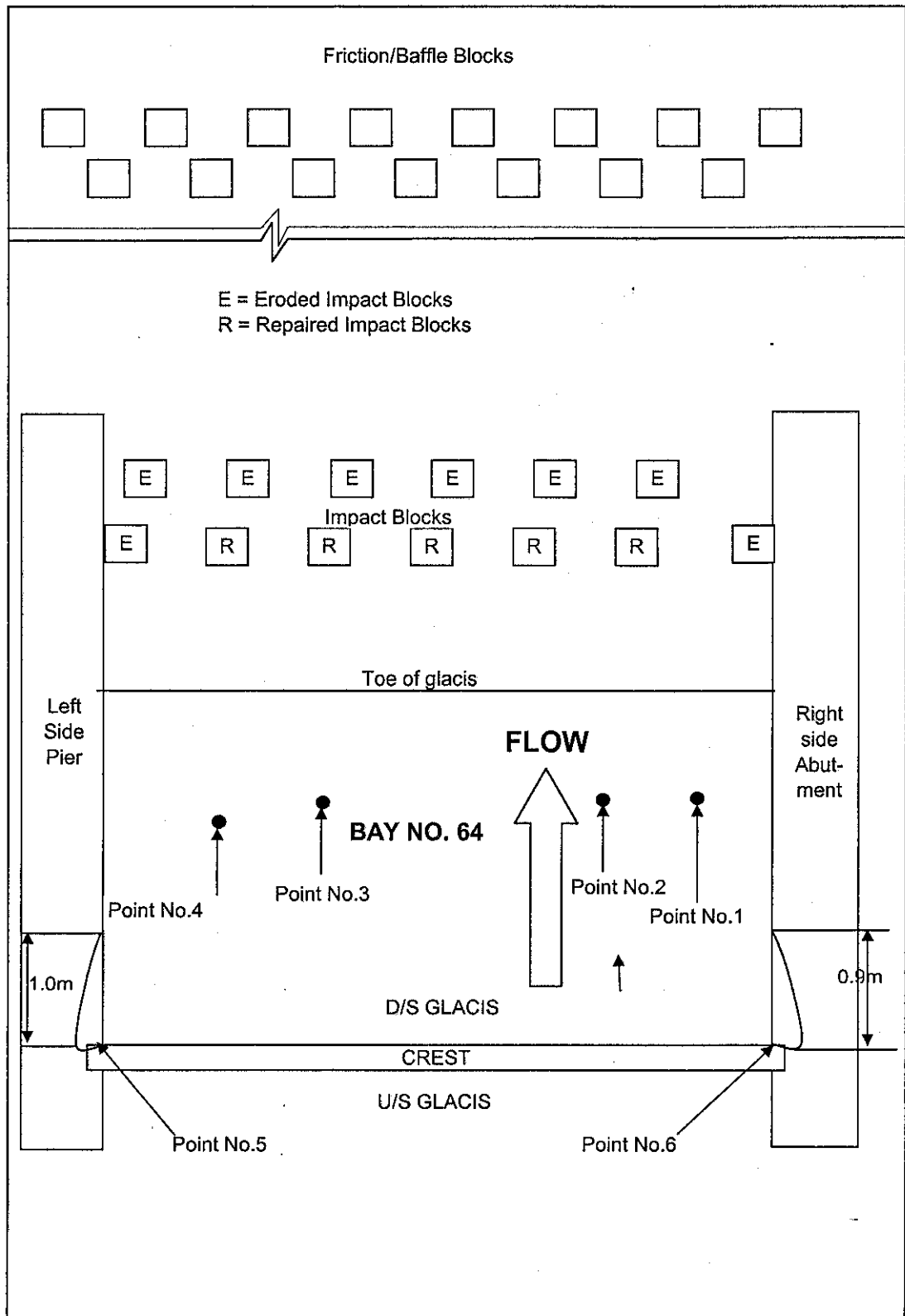

Report of damage conditions.

Ref No; Point No.01	Survey date: 14-01-2004
Location. D/S of 64th Gate/Bay from left side. (Position diagram). Given below.	Outline of damage. Water leakage from repaired glacis

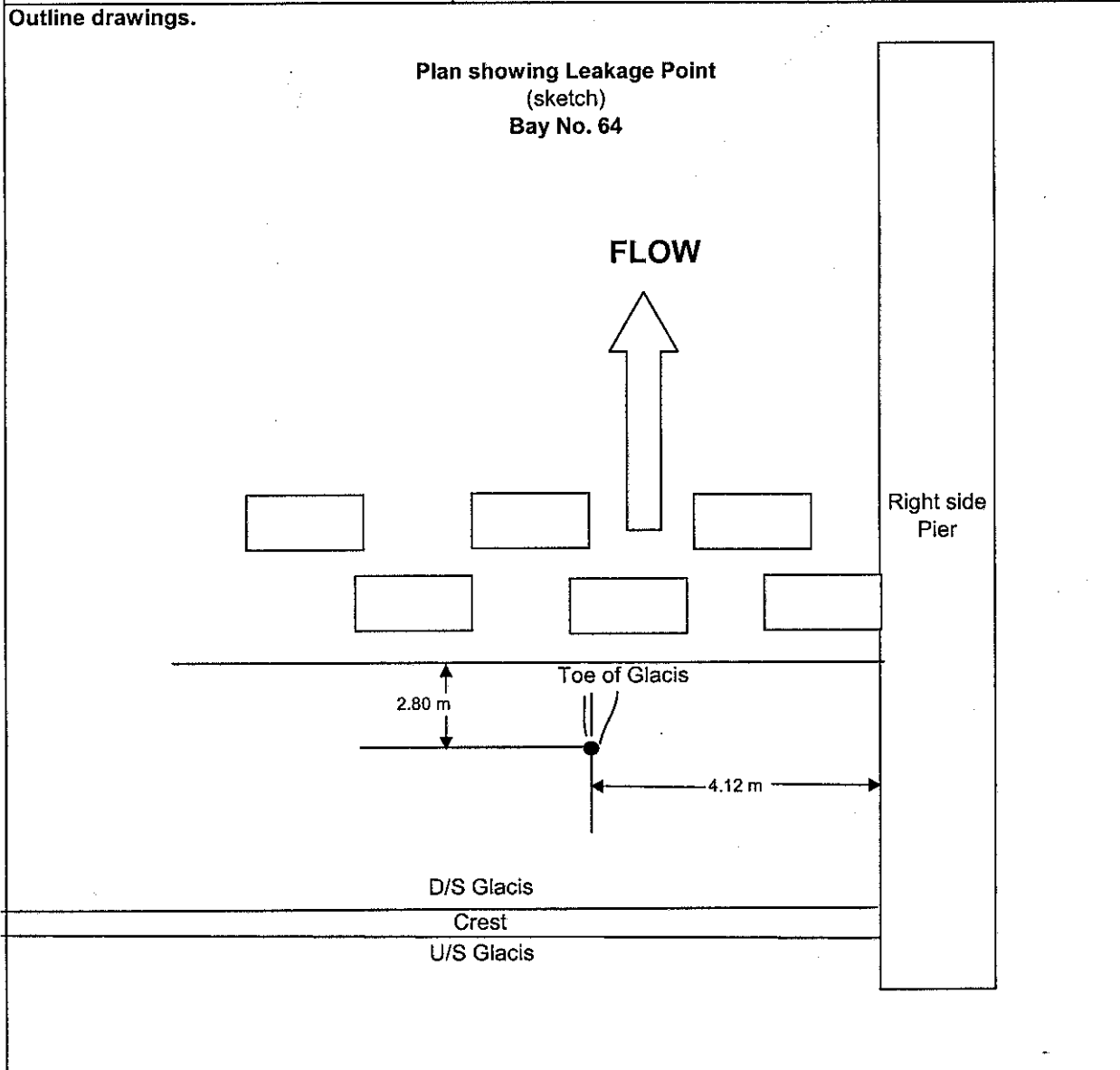

Note: Arrows shown for photographs indicate the angle at which the photographs were taken at site.

Report of damage conditions.

Ref No; Point No.02	Survey date: 14-01-2004
Location. D/S of 64th Gate/Bay from left side. (Position diagram). Given below.	Outline of damage. Water Leakage from the surface of repaired downstream glacis

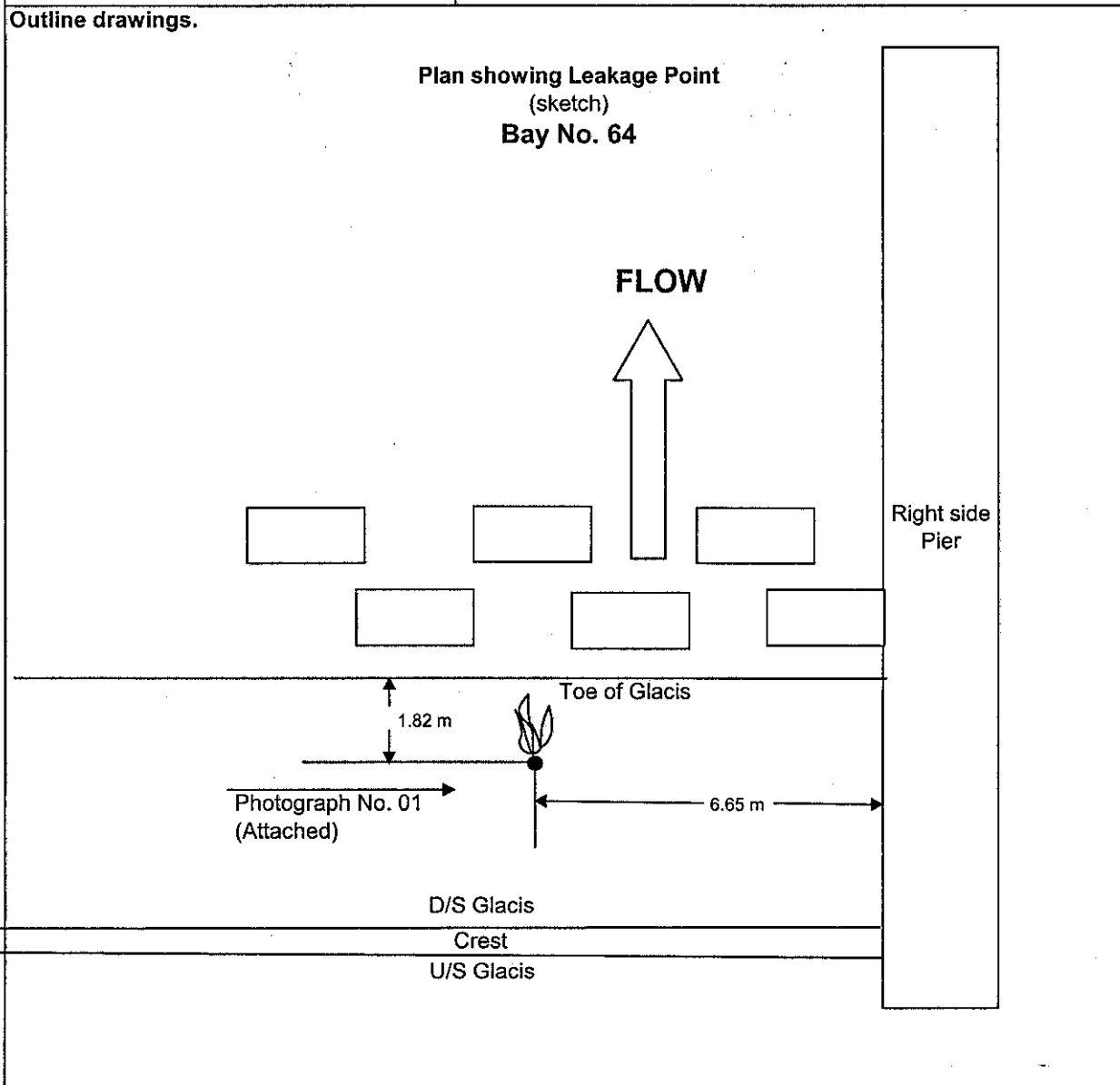

Note: Arrows shown for photographs indicate the angle at which the photographs were taken at site.

Bay No. 64

Water leakage from the surface of repaired D/S glacis



Photograph No. 01

Report of damage conditions.

Ref No; Point No.03	Survey date: 14-01-2004
<p>Location.</p> <p>D/S of 64th Gate/Bay from left side. (Position diagram).</p> <p>Given below.</p>	<p>Outline of damage.</p> <p>Water Leakage from the surface of D/S repaired glacis.</p>

Outline drawings.

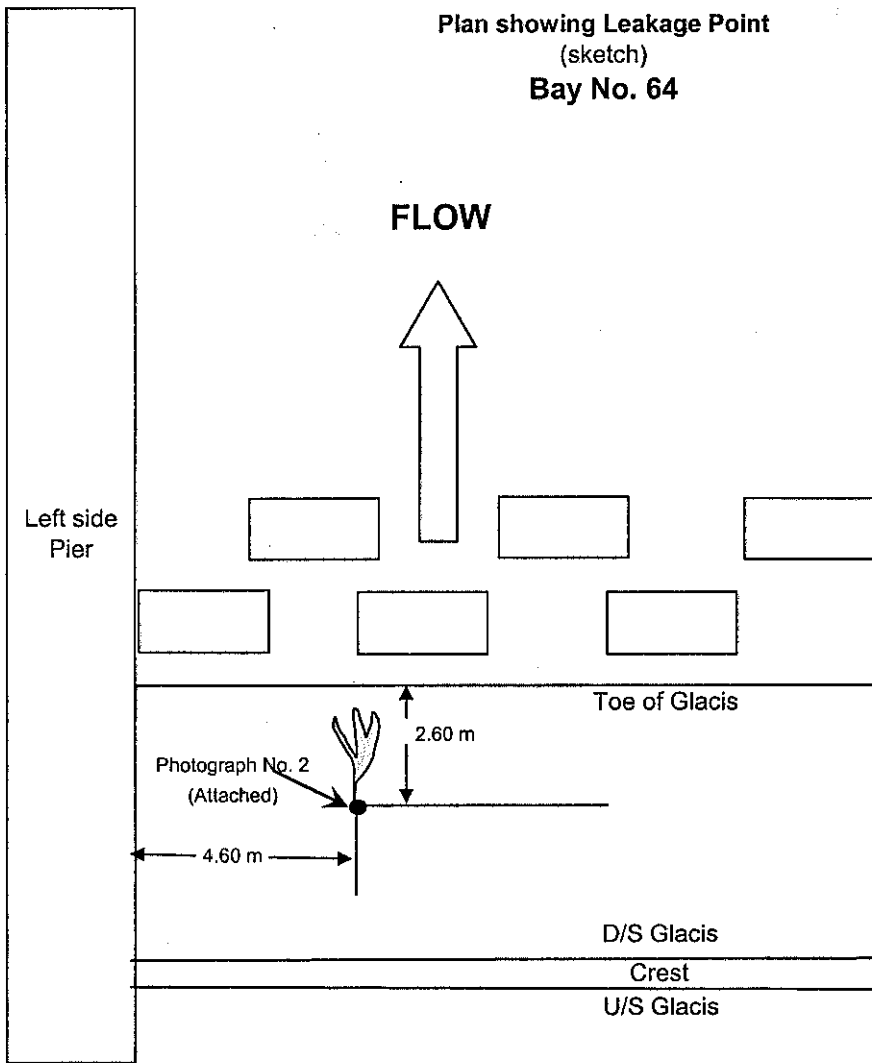

Note: Arrows shown for photographs indicate the angle at which the photographs were taken at site.

Bay No. 64

Water leakage from the surface of repaired D/S glacis



Photograph No. 02

Report of damage conditions.

Ref No; Point No.04	Survey date: 14-01-2004
Location. D/S of 64th Gate/Bay from left side. (Position diagram). Given below.	Outline of damage. Water Leakage from the surface of repaired downstream glacis

Outline drawings.

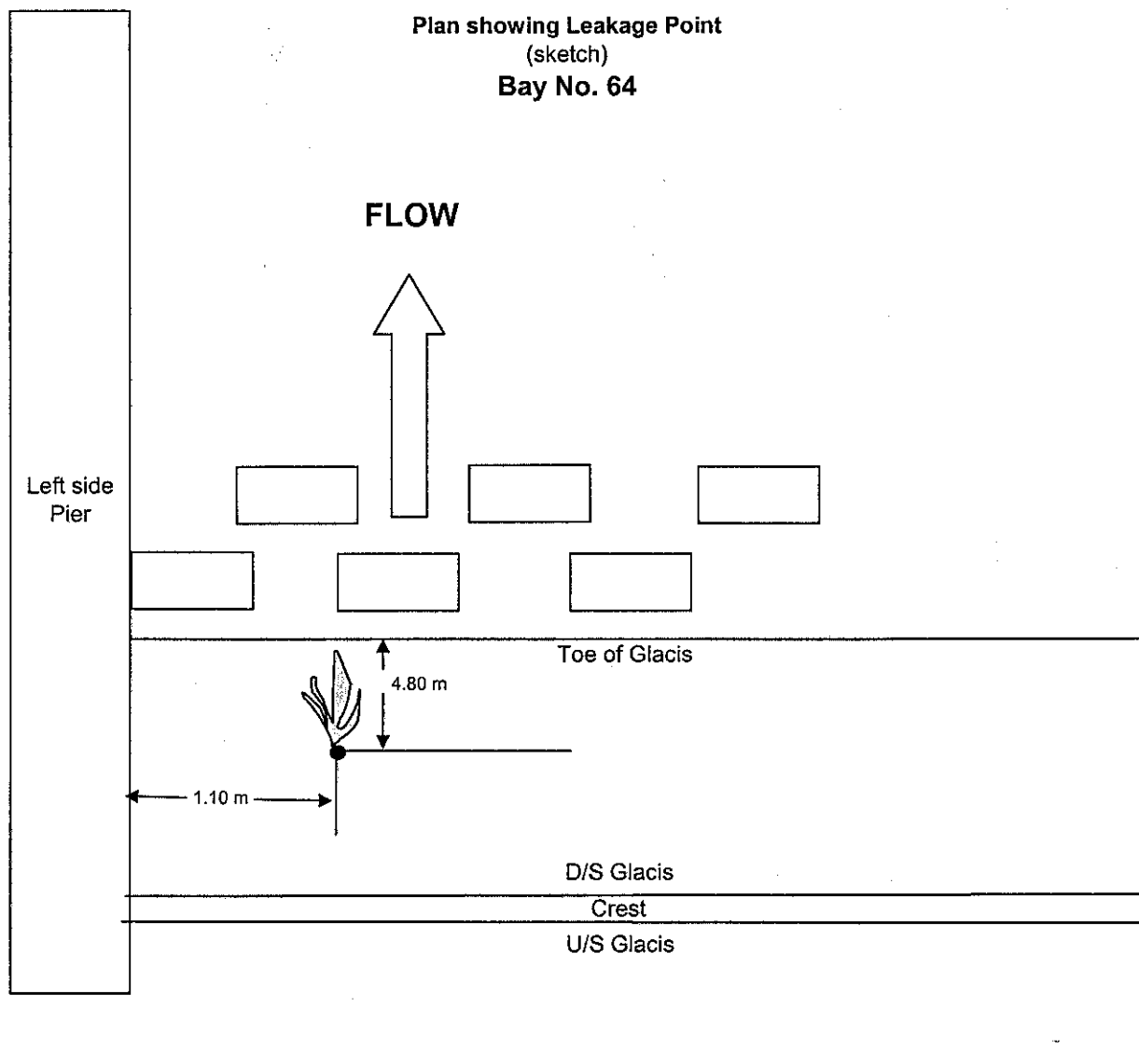

Note: Arrows shown for photographs indicate the angle at which the photographs were taken at site.

Report of damage conditions.

Ref No; Point No.05	Survey date: 14-01-2004
<p>Location.</p> <p>D/S of 64th Gate/Bay from left side. (Position diagram).</p> <p>Given below.</p>	<p>Outline of damage.</p> <p>Erosion of Pier due to high velocity flow passing down below the gates.</p>

Outline drawings.

**Section showing erosion of Pier near its bottom.
(Sketch)
Bay No. 64**

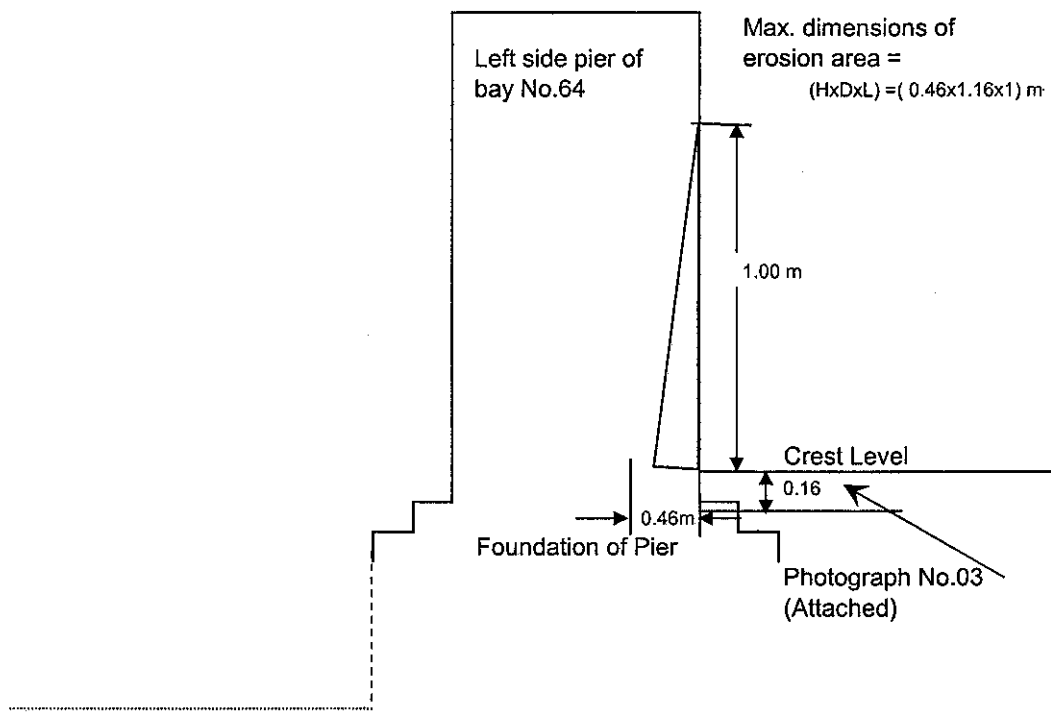

Note: Arrows shown for photographs indicate the angle at which the photographs were taken at site.

Bay No. 64

Erosion of due to high velocity flow passing down below the gate.



Photograph No. 03

Report of damage conditions.

Ref No; Point No.06	Survey date: 14-01-2004
<p>Location.</p> <p>D/S of 64th Gate/Bay from left side. (Position diagram).</p> <p>Given below.</p>	<p>Outline of damage.</p> <p>Erosion of Pier due to high velocity flow passing down below the gates.</p>

Outline drawings.

**Section showing Erosion of Pier near its Bottom
(Sketch)
Bay No. 64**

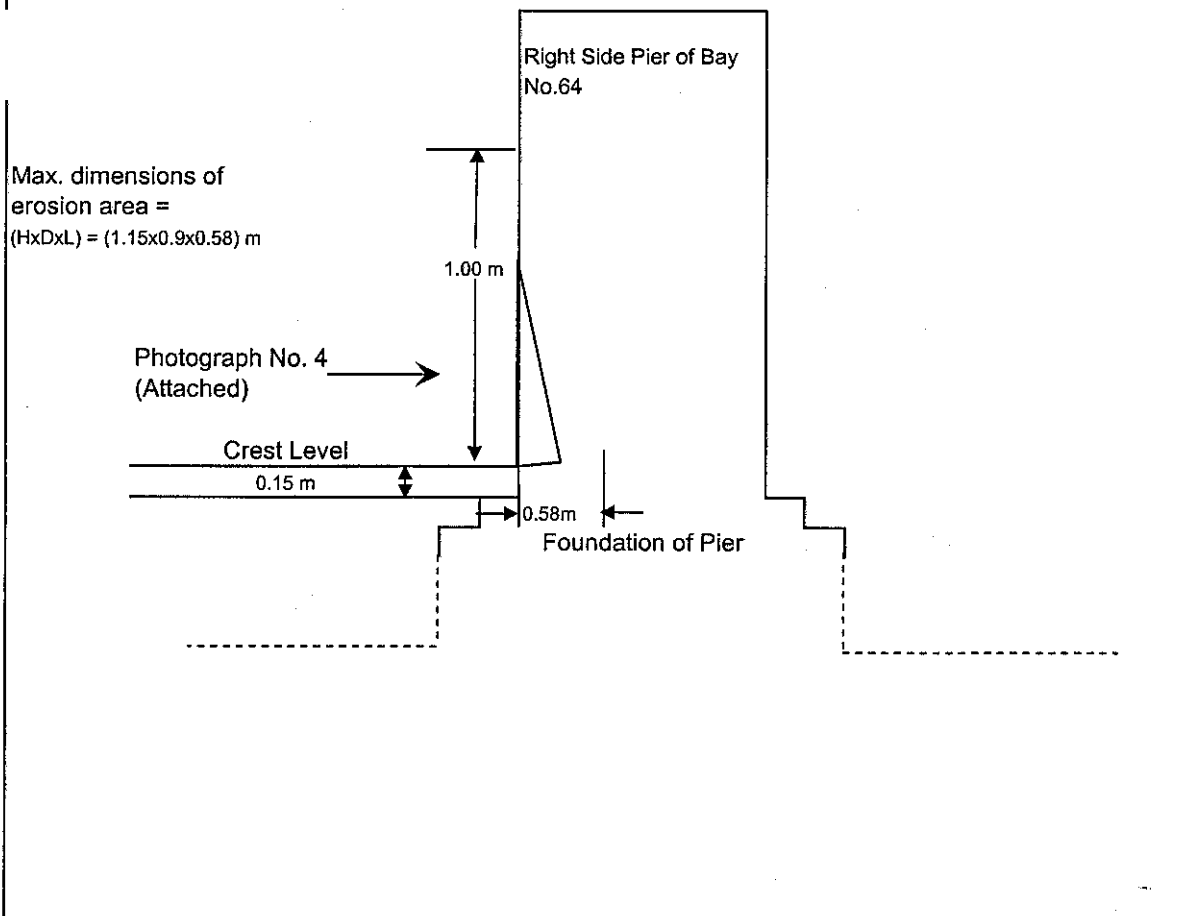

Note: Arrows shown for photographs indicate the angle at which the photographs were taken at site.

Bay No. 64

Erosion of due to high velocity flow passing down below the gate.



Photograph No. 04

FORMATS OF DAMAGE CONDITIONS

BAY NO. 63

FORMATS OF DAMAGE CONDITIONS-BAY NO. - 63

Table of Contents

- 1) Index Plan showing damage points in Bay No. - 63**
- 2) Point No. 1 – Erosion of pier due to high velocity flow passing down below the gates.**
- 3) Point No. 2 – Erosion of pier due to high velocity flow passing down below the gates.**
- 4) Point No. 3 – Seeping water from construction joints of downstream glacis.**
- 5) Point No. 4 – Erosion of downstream glacis surface due to high velocity flow.**
- 6) Point No. 5 – Uprooting/cracking of friction/baffle block due to undissipated energy of high velocity jet (under conditions of excessive retrogression on the D/S side).**
- 7) Point No. 6 – Due to high velocity flow the skin concrete at the crest is eroded and reinforcement steel is exposed.**

Index Plan Showing Damage Points In

Bay No; 63 From Left

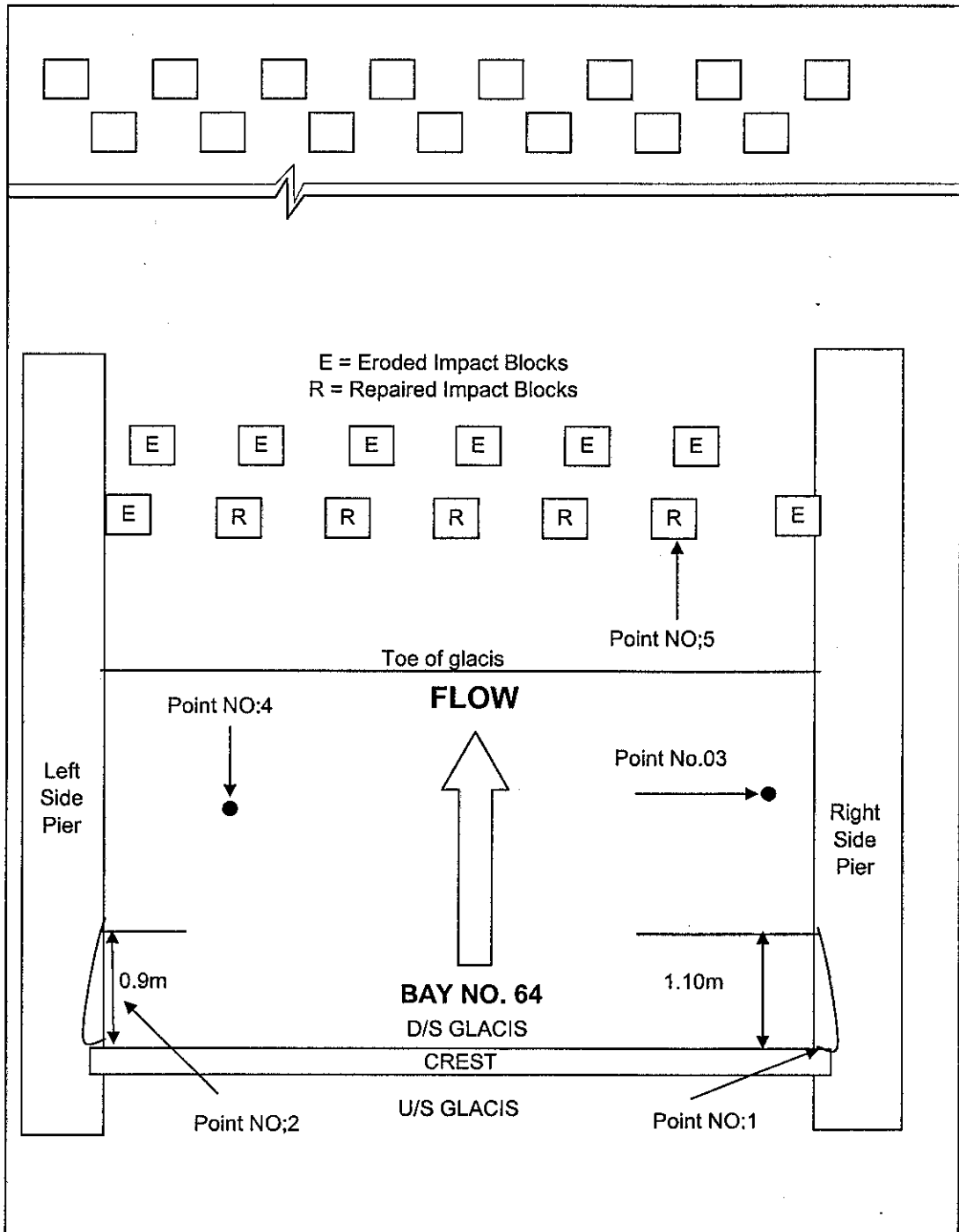

Report of damage conditions.

Ref No; Point No;01	Survey date: 14-01-2004
Location. D/S of 63rd Gate/Bay from left side. (Position diagram). Given below.	Outline of damage. Erosion of Pier due to high velocity flow passing down below the gates.

Outline drawings.

**Section showing Erosion of Pier near its Bottom
(Sketch)
Bay No; 63**

Max. dimensions of erosion area = (HxDxL)=(0.9x1x0.55)

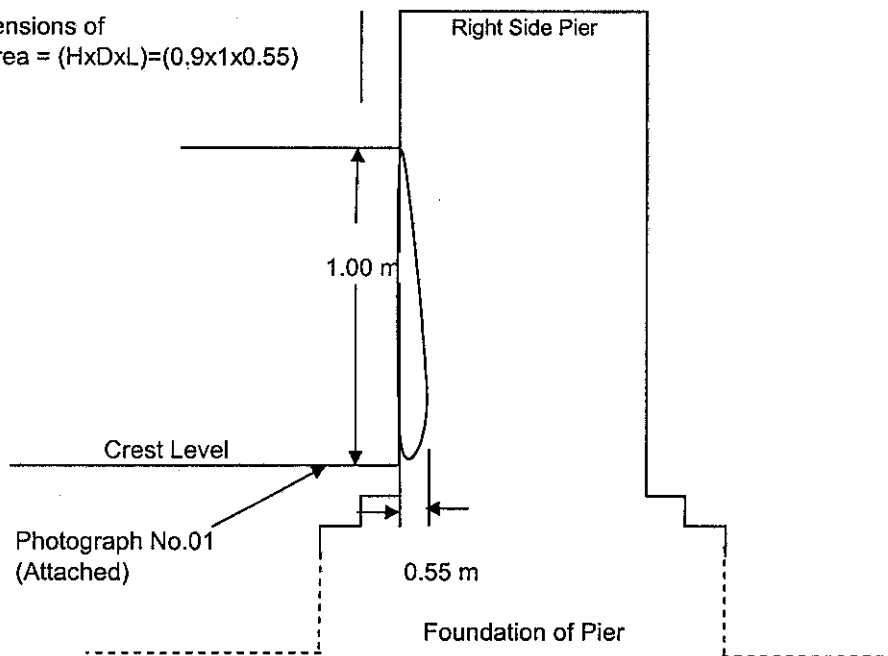

Note: Arrows shown for photographs indicate the angle at which the photographs were taken at site.

Bay No. 63

Erosion of piers due to high velocity flow passing down below the gates



Photograph No. 01

Report of damage conditions.

Ref No; Point No;02	Survey date: 14-01-2004
Location. D/S of 63rd Gate/Bay from left side. (Position diagram). Given below.	Outline of damage. Erosion of Pier due to high velocity flow passing down below the gates.

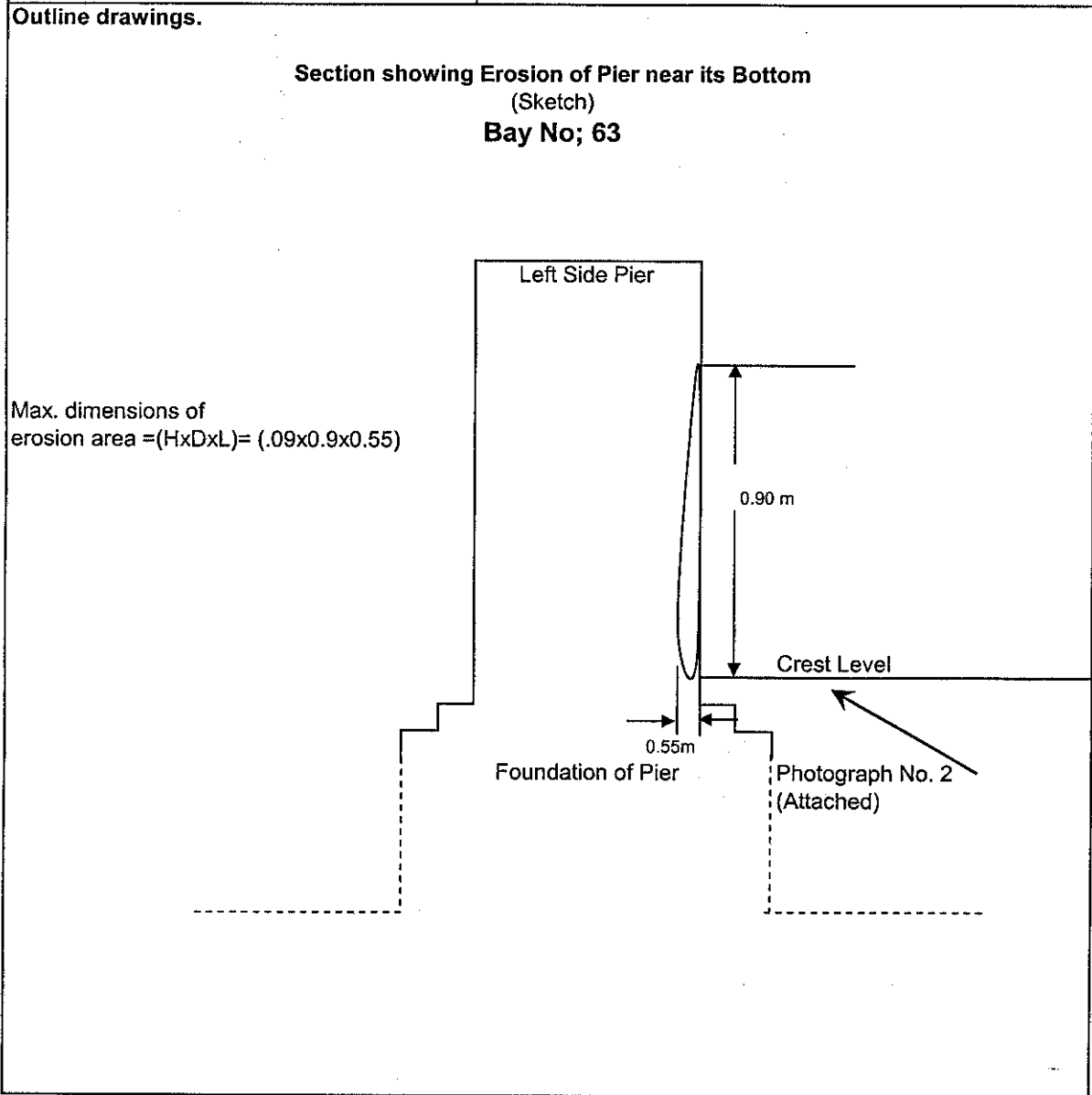

Note: Arrows shown for photographs indicate the angle at which the photographs were taken at site.

Bay No. 63

Erosion of piers due to high velocity flow passing down below the gates



Photograph No. 02

Report of damage conditions.

Ref No; Point No;03	Survey date: 14-01-2004
<p>Location.</p> <p>D/S of 63rd Gate/Bay from left side. (Position diagram).</p> <p>Given below.</p>	<p>Outline of damage.</p> <p>Broken Edges of Construction Joint in the Floor - at the Location shown below.</p>

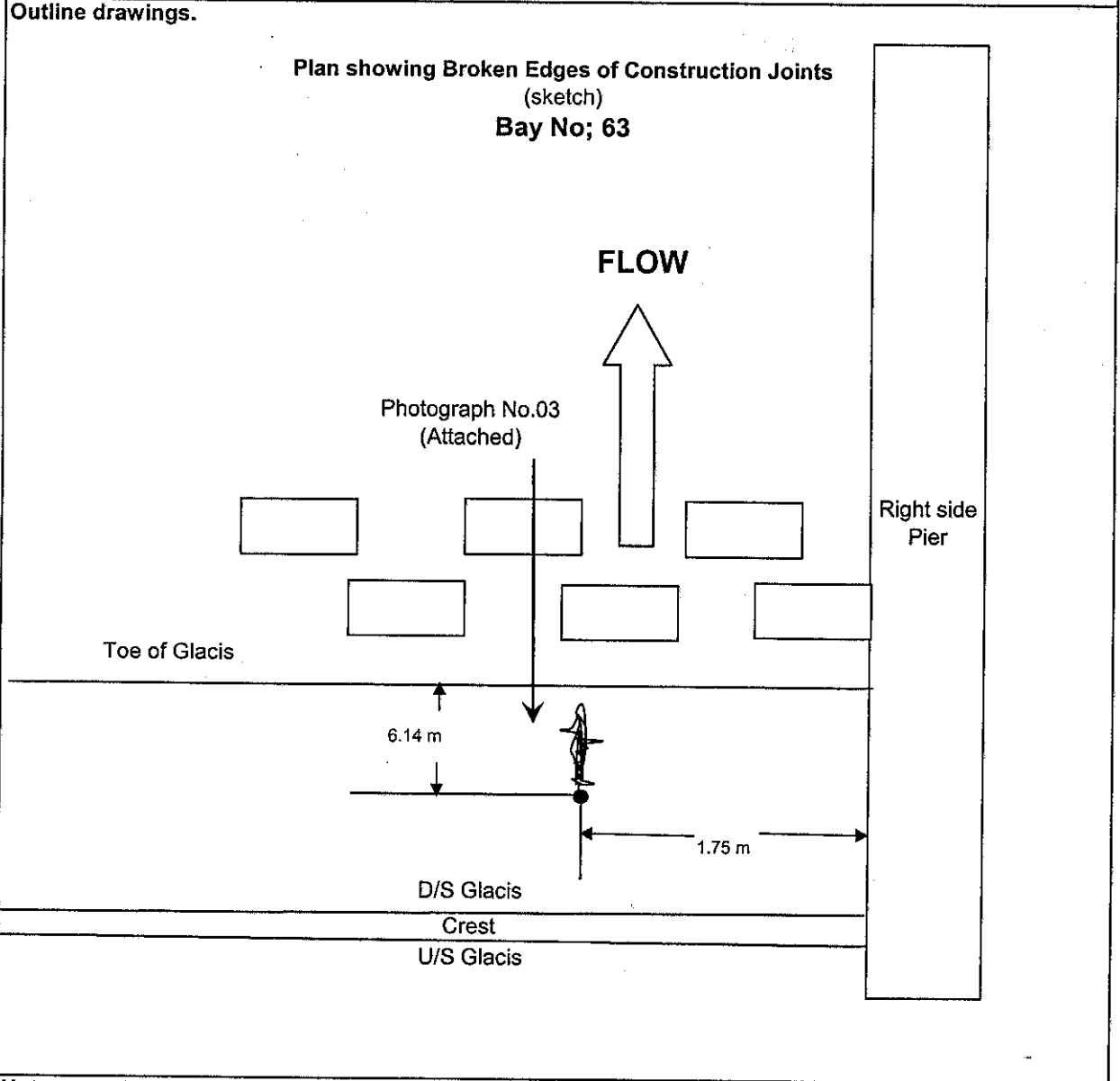

Note: Arrows shown for photographs indicate the angle at which the photographs were taken at site.

Bay No. 63

Seeping water from construction joints of D/S glacis



Photograph No. 03

Report of damage conditions.

Ref No; Point No;04	Survey date: 14-01-2004
Location. D/S of 63rd Gate/Bay from left side. (Position diagram). Given below.	Outline of damage. Erosion of D/S Glacis Surface due to High Velocity Flow at the location shown below:

Outline drawings.

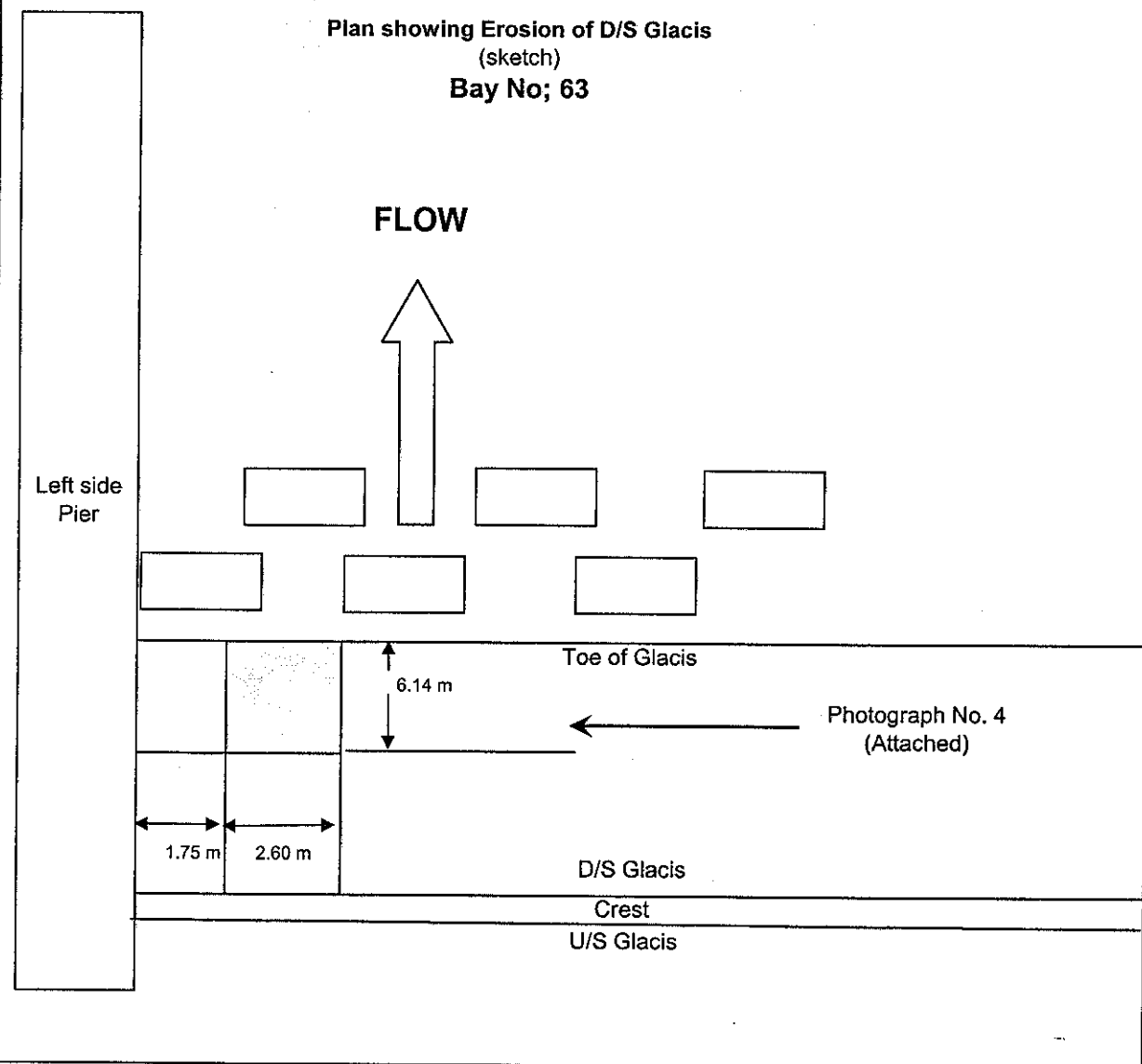

Note: Arrows shown for photographs indicate the angle at which the photographs were taken at site.

Bay No. 63

Erosion of D/S glacis due to high velocity flow and Broken construction joints.

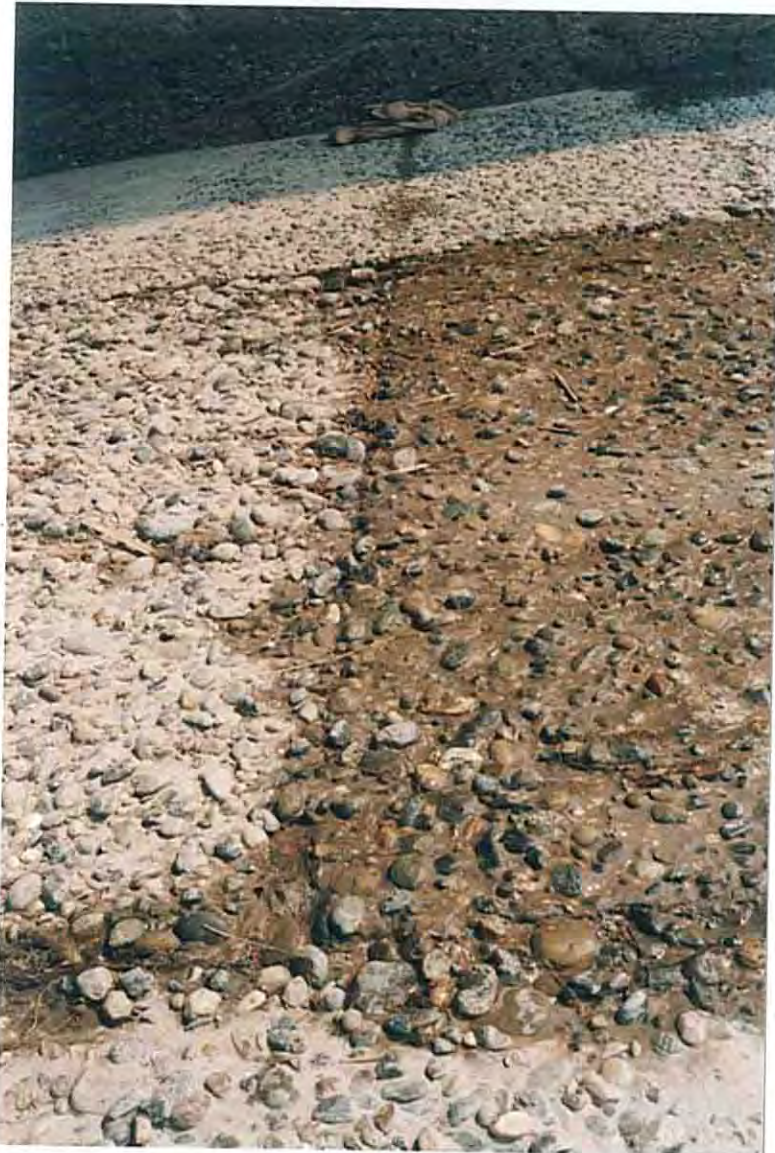

Photograph No. 04

Report of damage conditions.

Ref No; Point No;05	Survey date: 14-01-2004
<p>Location.</p> <p>D/S of 63rd Gate/Bay from left side. (Position diagram). Given below.</p>	<p>Outline of damage.</p> <p>Uprooting/Cracking of Friction/Baffle Block due to un-dissipated energy of high-velocity jet (under conditions of excessive retrogression on the D/S side) - at the location shown below:-</p>

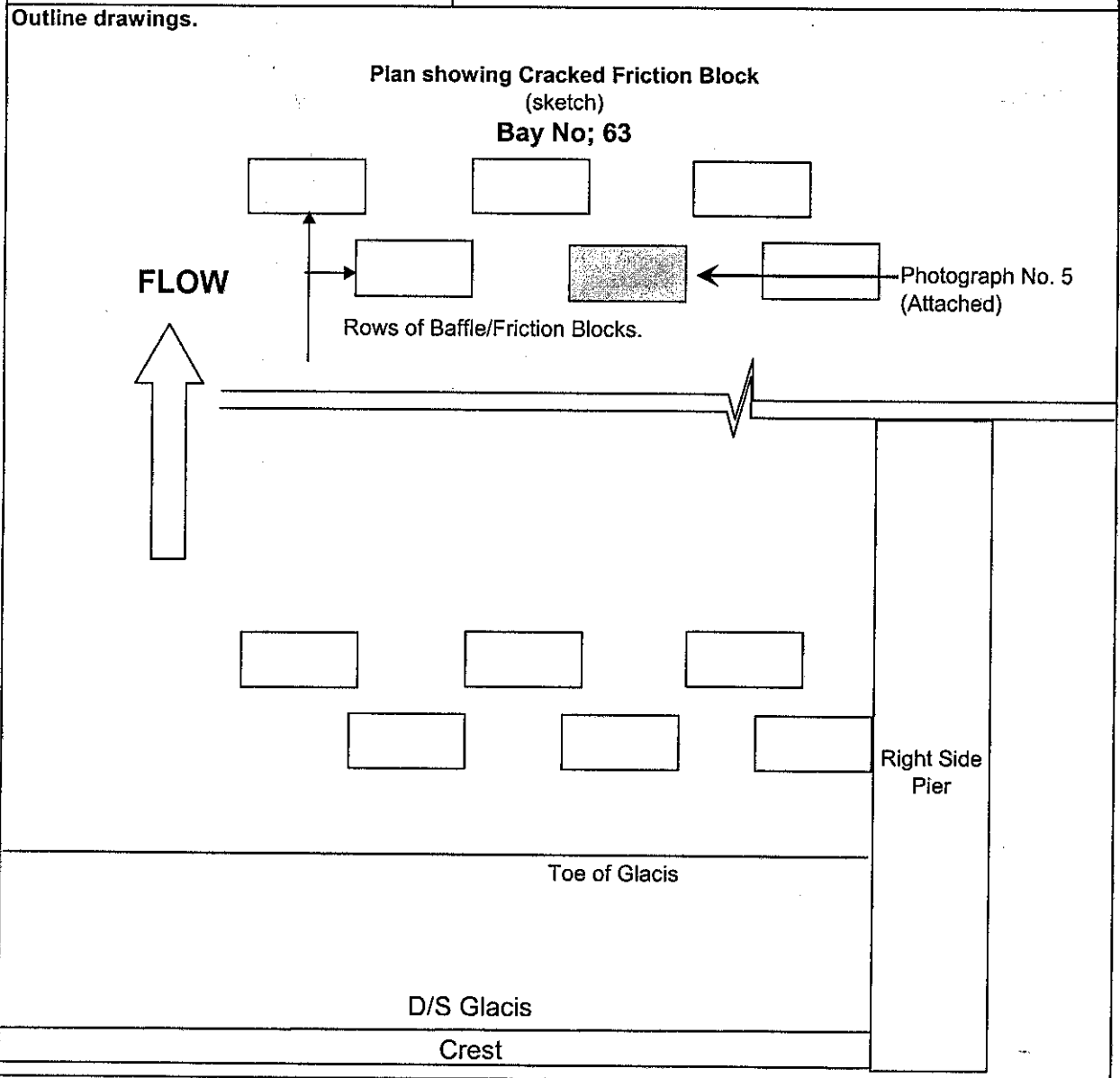

Note: Arrows shown for photographs indicate the angle at which the photographs were taken at site.

Bay No. 63

Uprooting/damage to the friction/baffle blocks due to undissipated energy of high velocity
(under condition of excessive retrogression on the D/S side)



Photograph No. 05

Report of damage conditions.

Ref No; Point No;06	Survey date: 14-01-2004
<p>Location.</p> <p>D/S of 63rd Gate/Bay from left side. (Position diagram). Given below.</p>	<p>Outline of damage.</p> <p>Due to High Velocity flow the skin concrete at the Crest is eroded and reinforcement steel is exposed.</p>

Outline drawings.

**Plan showing area at the Crest
(sketch)
Bay No; 63**

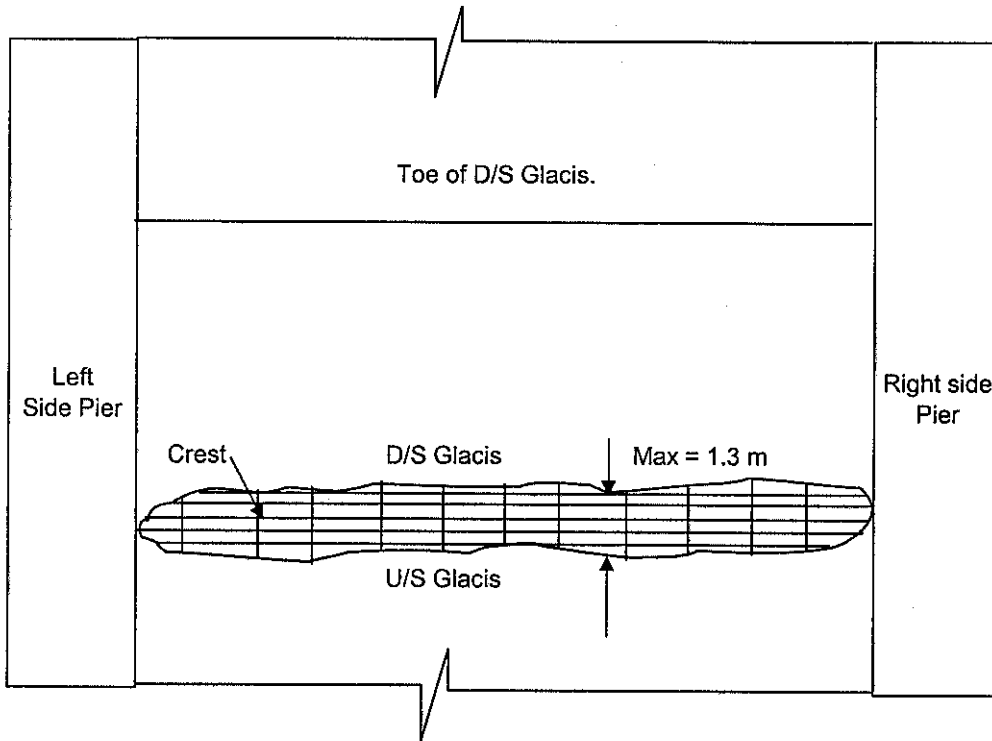

Note: Arrows shown for photographs indicate the angle at which the photographs were taken at site.

ANNEX. V

FORMATS OF DAMAGE CONDITIONS

BAY NO. 62

FORMATS OF DAMAGE CONDITIONS-BAY NO. - 62

Table of Contents

- 1) Index Plan showing damage points in Bay No. - 62**
- 2) Point No. 1 - Erosion of piers due to high velocity flow near its bottom.**
- 3) Point No. 2 - Erosion of Pier due to high velocity flow near its bottom.**
- 4) Point No. 3 - Erosion of concrete skin at crest, exposing reinforcement across almost entire width of Bay.**
- 5) Point No. 4 - Erosion of Impact Blocks due to high velocity flow with undissipated energy (as a result of excessive retrogression on the D/S side)**
- 6) Point No. 5 - Erosion of Impact Blocks due to high velocity flow with undissipated energy (as a result of excessive retrogression on the D/S side)**

Index Plan Showing Damage Points In

Bay No. 62 From Left (Sketch)

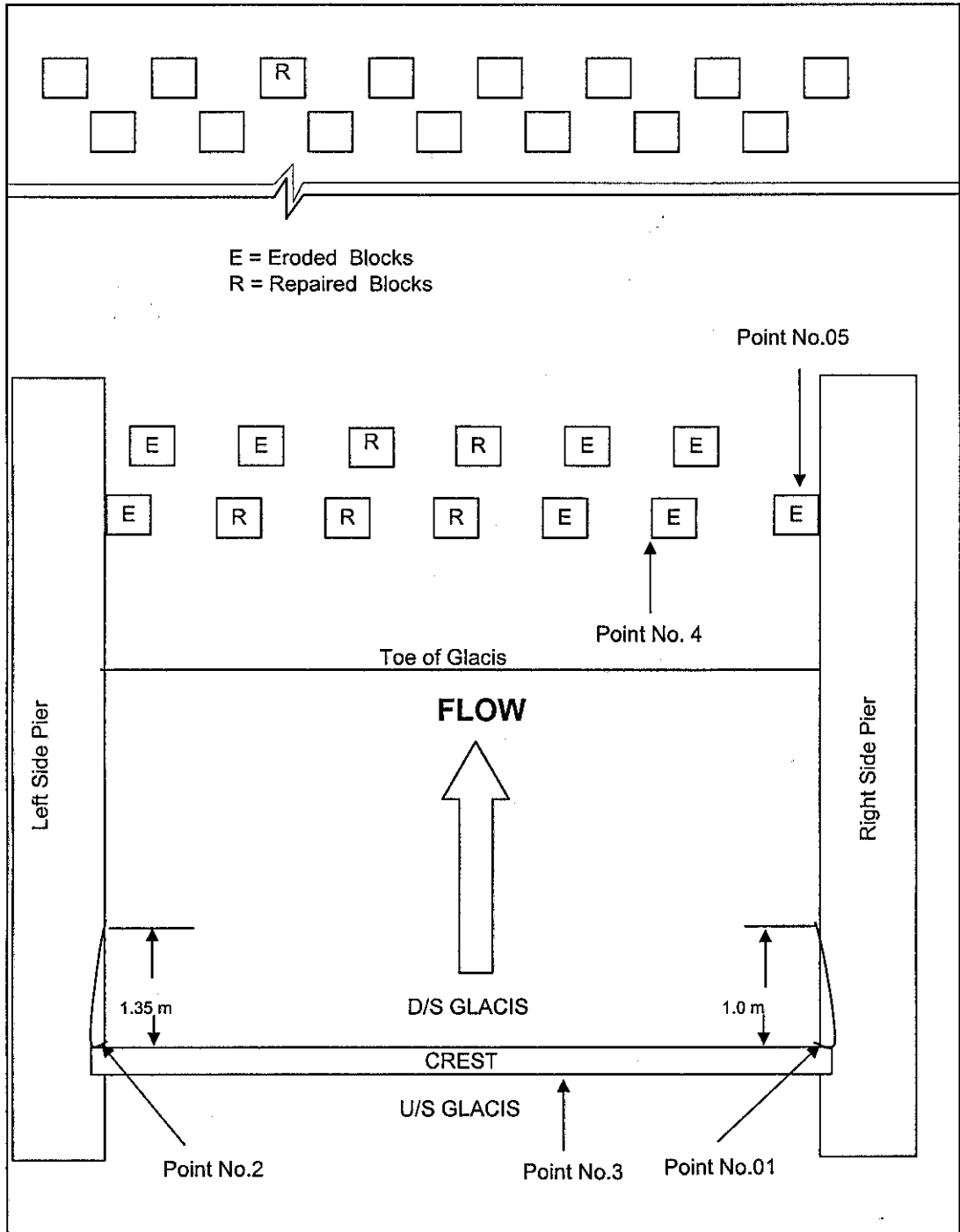

Report of damage conditions.

Ref No. Point No.01	Survey date: 14-01-2004
Location. D/S of 62nd Gate/Bay from left side. (Position diagram). Given below.	Outline of damage. Erosion of Piers due to high velocity flow near its bottom.

Outline drawings.

Section showing erosion of Pier near its bottom
 (sketch)
Bay No. 62

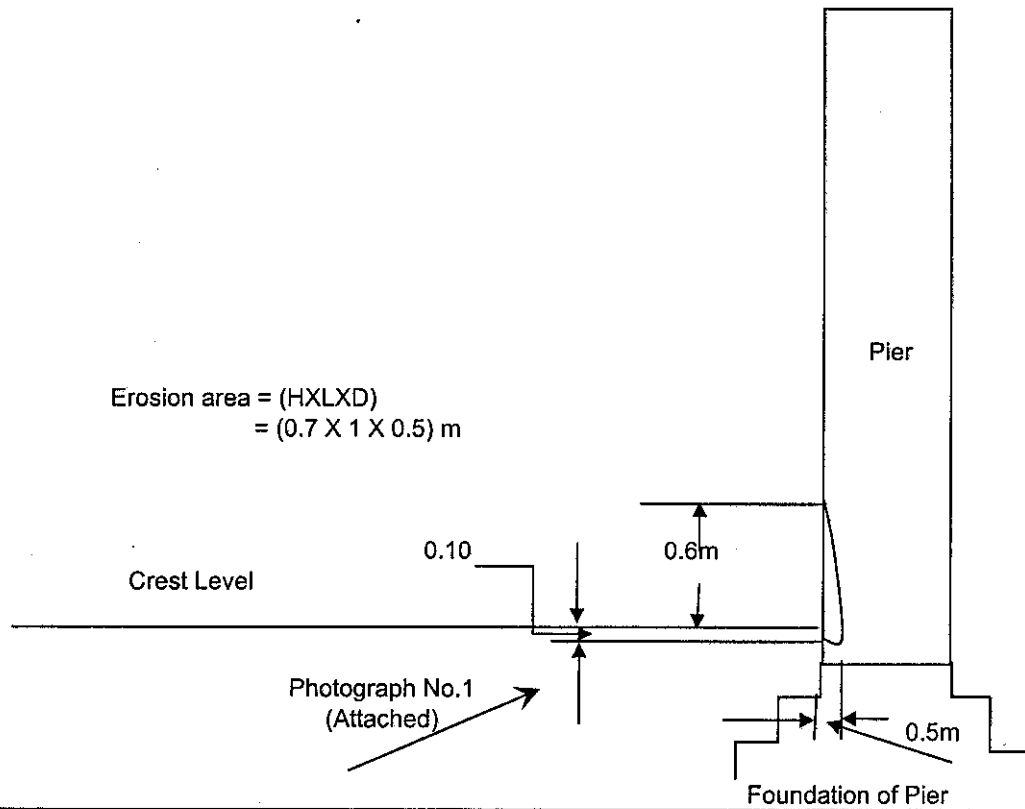

Note: Arrows shown for photographs indicate the angle at which the photographs were taken at site.

Bay No. 62
Erosion of Pier
Due to high velocity flow
near its bottom



Photograph No. 01

Report of damage conditions.

Ref No; Point No.02	Survey date: 14-01-2004
Location. D/S of 62nd Gate/Bay from left side. (Position diagram). Given below.	Outline of damage. Erosion of Pier due to high velocity flow near its bottom

Outline drawings.

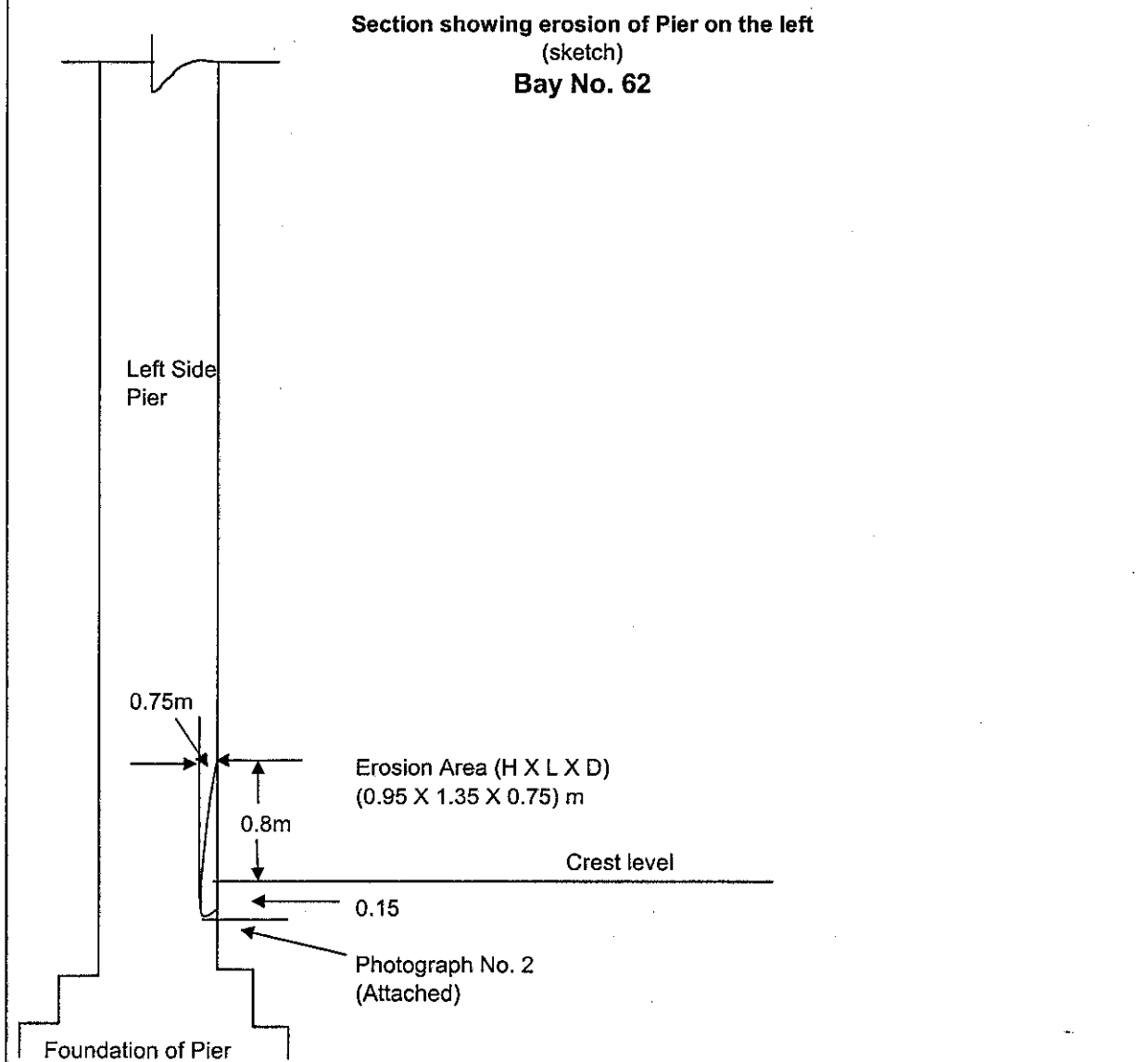

Note: Arrows shown for photographs indicate the angle at which the photographs were taken at site.

Bay No. 62
Erosion of pier
due to high velocity flow
near its bottom



Photograph No. 02

Report of damage conditions.

Ref No: Point No.03	Survey date: 14-01-2004
Location. D/S of 62nd Gate/Bay from left side. (Position diagram). Given below.	Outline of damage. Erosion of concrete skin at crest, exposing reinforcement across almost entire width of Bay

Outline drawings.

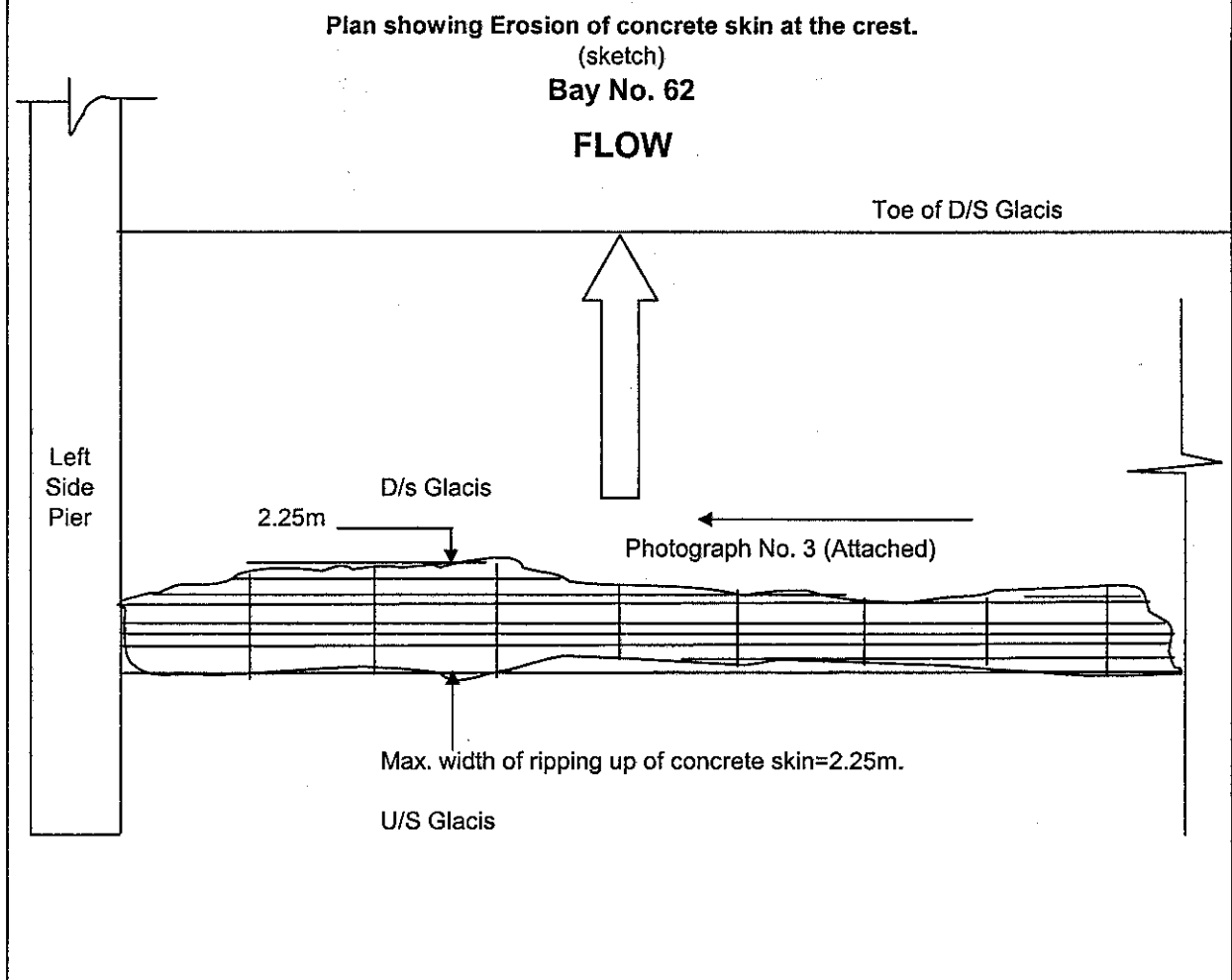

Note: Arrows shown for photographs indicate the angle at which the photographs were taken at site.

Bay No. 62
Erosion of concrete
skin at the crest



Photograph No. 03

Report of damage conditions.

Ref No. Point No. 04	Survey date: 14-01-2004
<p>Location.</p> <p>D/S of 62nd Gate/Bay from left side. (Position diagram).</p> <p>Given below.</p>	<p>Outline of damage.</p> <p>Erosion of Impact Blocks due to high velocity flow with undissipated energy (as a result of excessive retrogression on the D/S side) - at the location shown below:-</p>

Outline drawings.

**Plan showing erosion of impact Blocks
(sketch)
Bay No. 62**

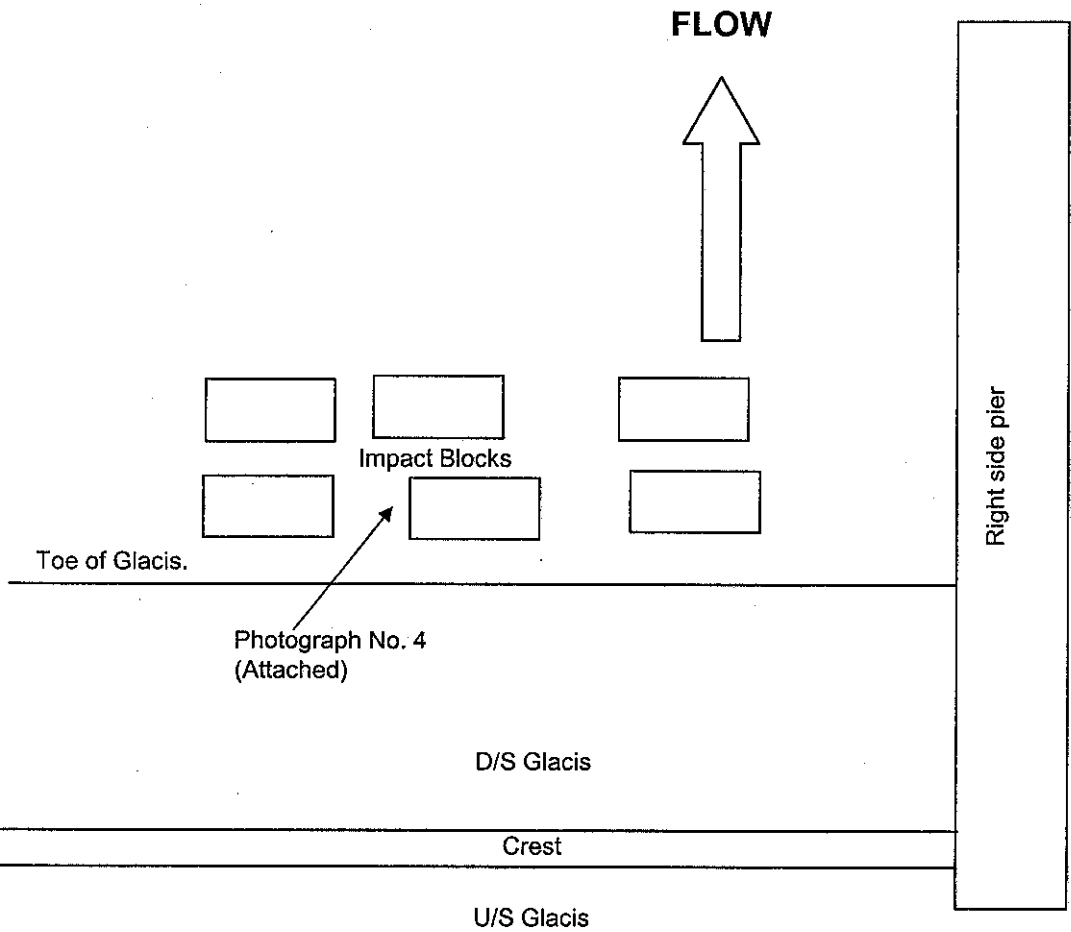

Note: Arrows shown for photographs indicate the angle at which the photographs were taken at site.

201

Bay No. 62
Erosion of impact blocks



Photograph No. 04

Report of damage conditions.

Ref No. Point No. 05	Survey date: 14-01-2004
<p>Location.</p> <p>D/S of 62nd Gate/Bay from left side. (Position diagram).</p> <p>Given below.</p>	<p>Outline of damage.</p> <p>Erosion of Impact Blocks due to high velocity flow with undissipated energy (as a result of excessive retrogression on the D/S side) - at the location shown below:-</p>

Outline drawings.

Plan showing erosion of impact blocks.
 (Sketch)
Bay No. 62

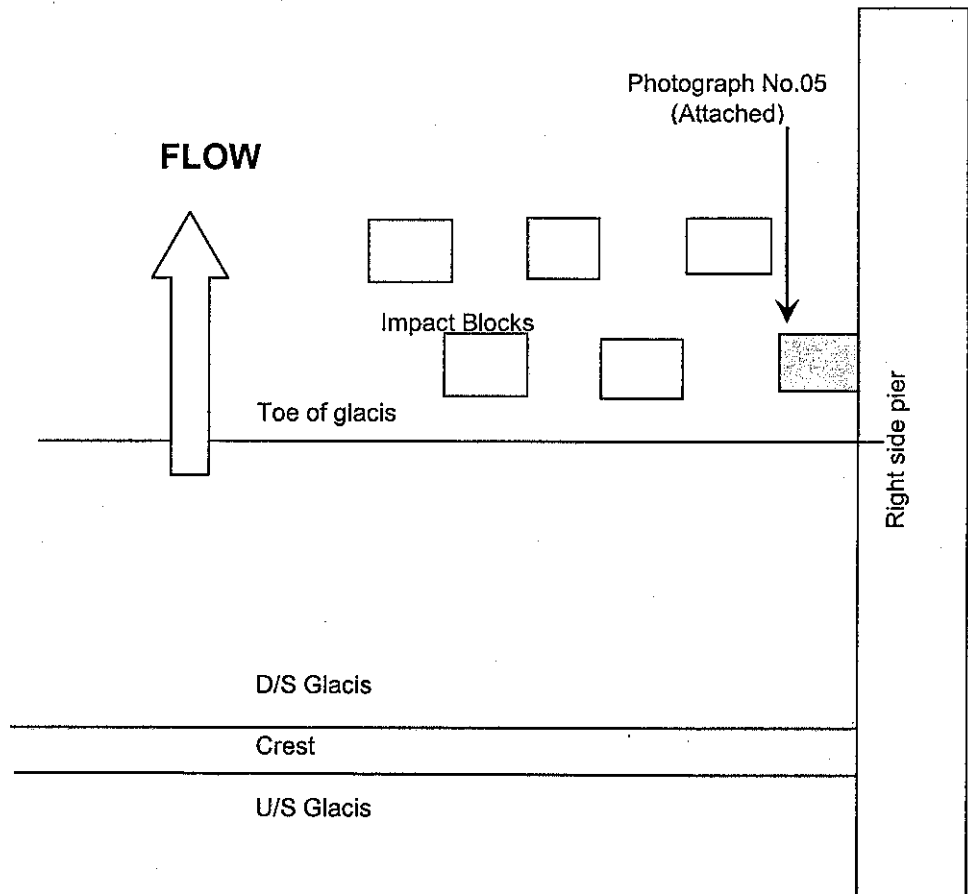

Note: Arrows shown for photographs indicate the angle at which the photographs were taken at site.

209

Bay No. 62
Erosion of impact blocks



Photograph No. 05