

## H.2 Description of the project and reasonable alternatives

### H.2.1 Location of the Moon Plains Landfill Site

The Moon Plains Existing Landfill Site is located in the plantation forest near Moon Plains Grama Seveka Division in Moon Plains village which faces Nuwara Eliya municipal council. The plantation forest where the landfill site is located belongs to the Forest Department. The code of forest is B/SB02/003. The trees of *E. grandis* planted in this site in 1975 are already enough matured. The distance from Nuwara Eliya town centre to the landfill site is approximately 6km.

The site to borrow covering soil material is at the Moon plain landfill site and Gregory Lake.

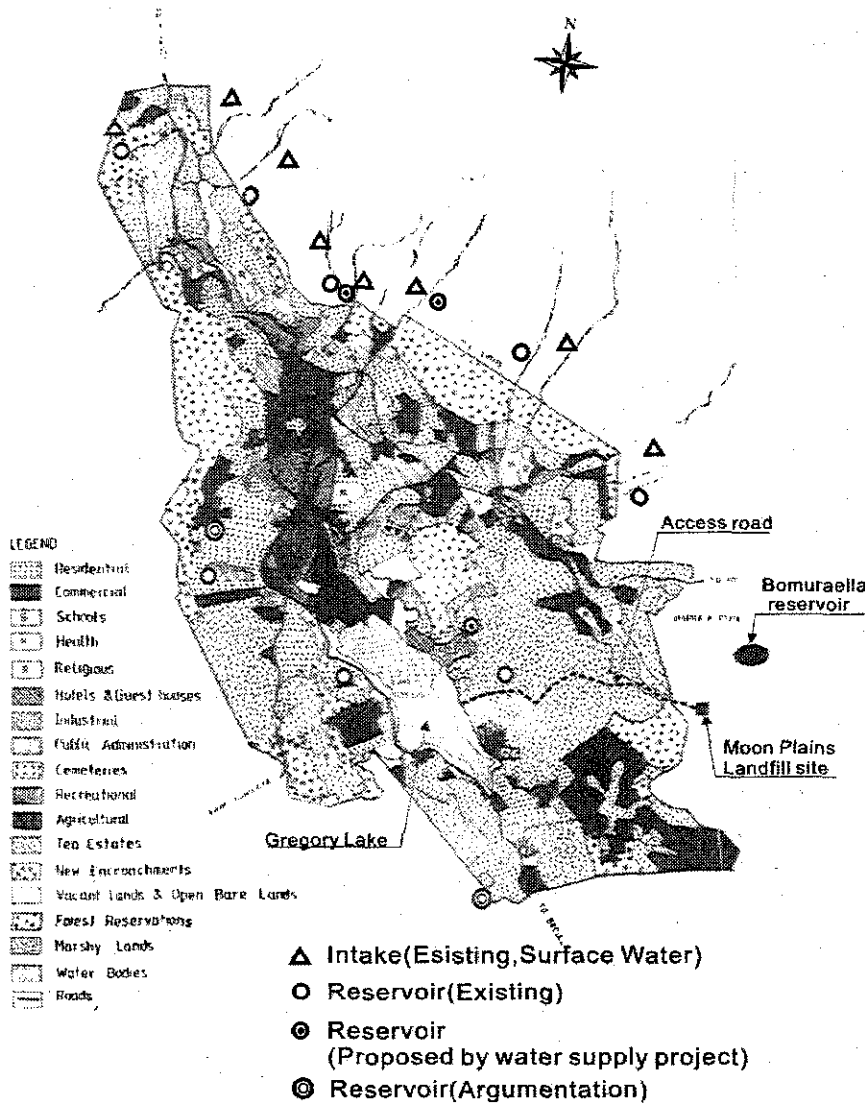
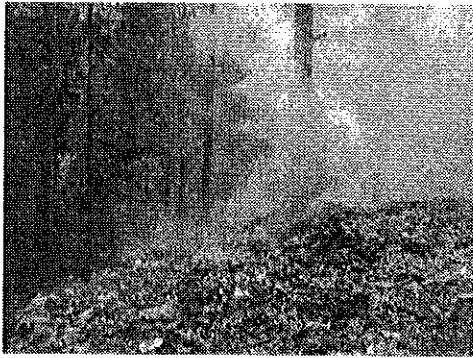
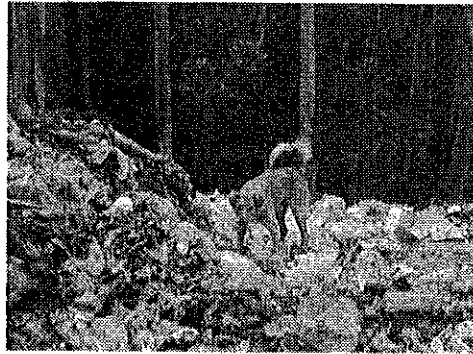

Figure H.2-1: Location of Moon Plains Existing Landfill Site



Fire & Smoke



Many Stray dogs



Many trees dying

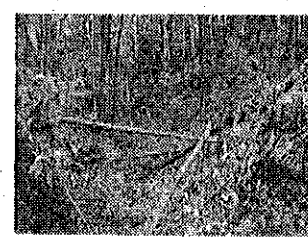

H-5

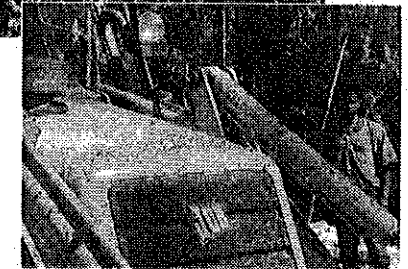
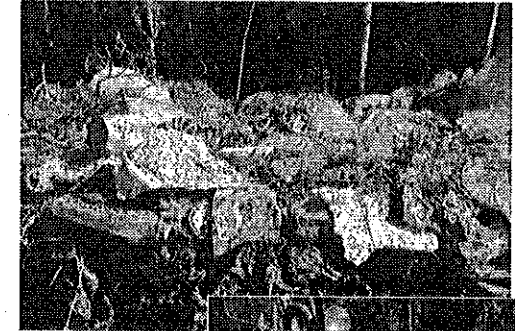
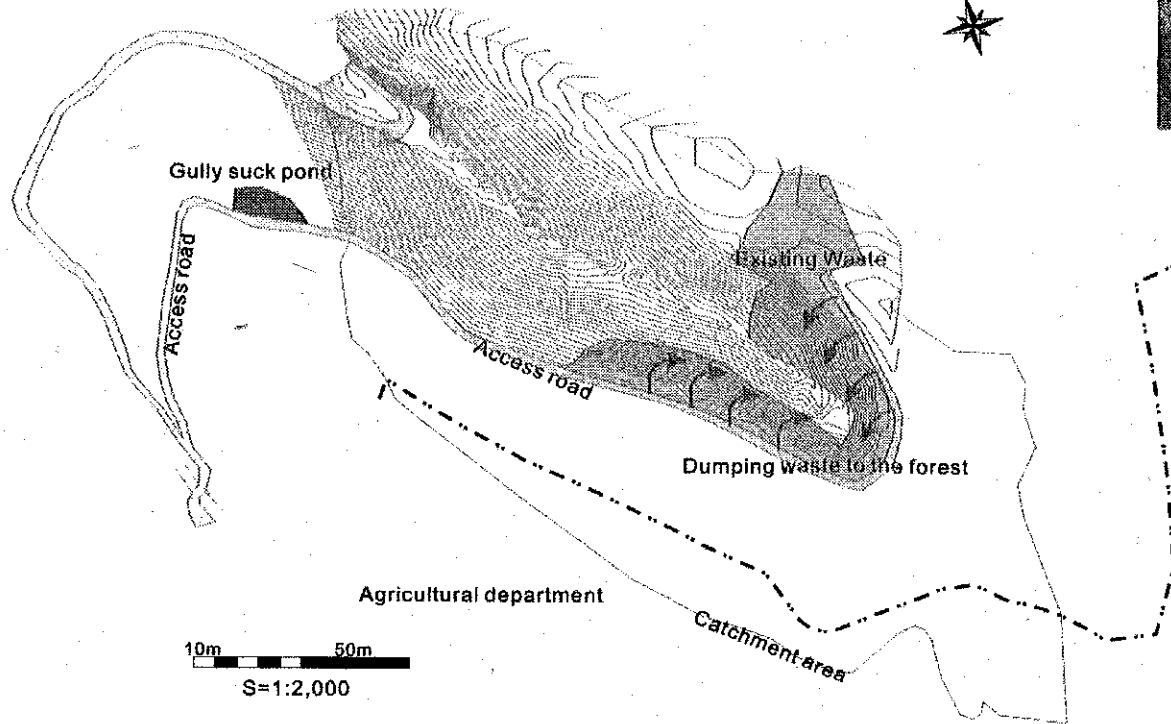

Many flies

Figure H.2-2: Current condition of Moon Plains Existing Landfill Site

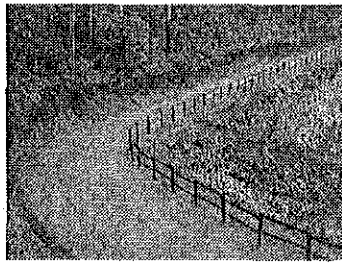

Access road

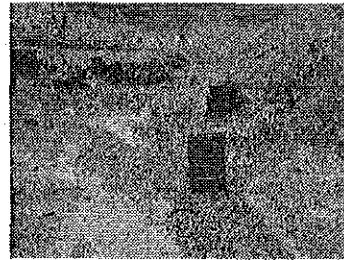

Gas ventilating facility

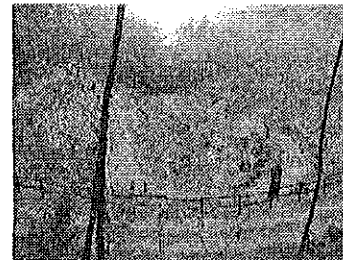

Relocation of existing waste & Covering soil

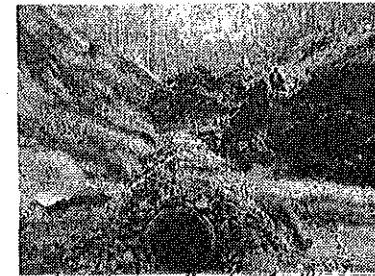

Leachate collection facility

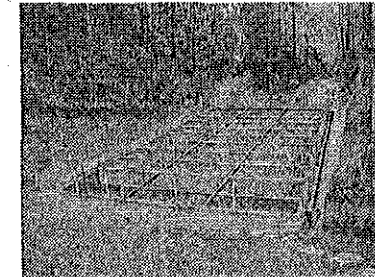
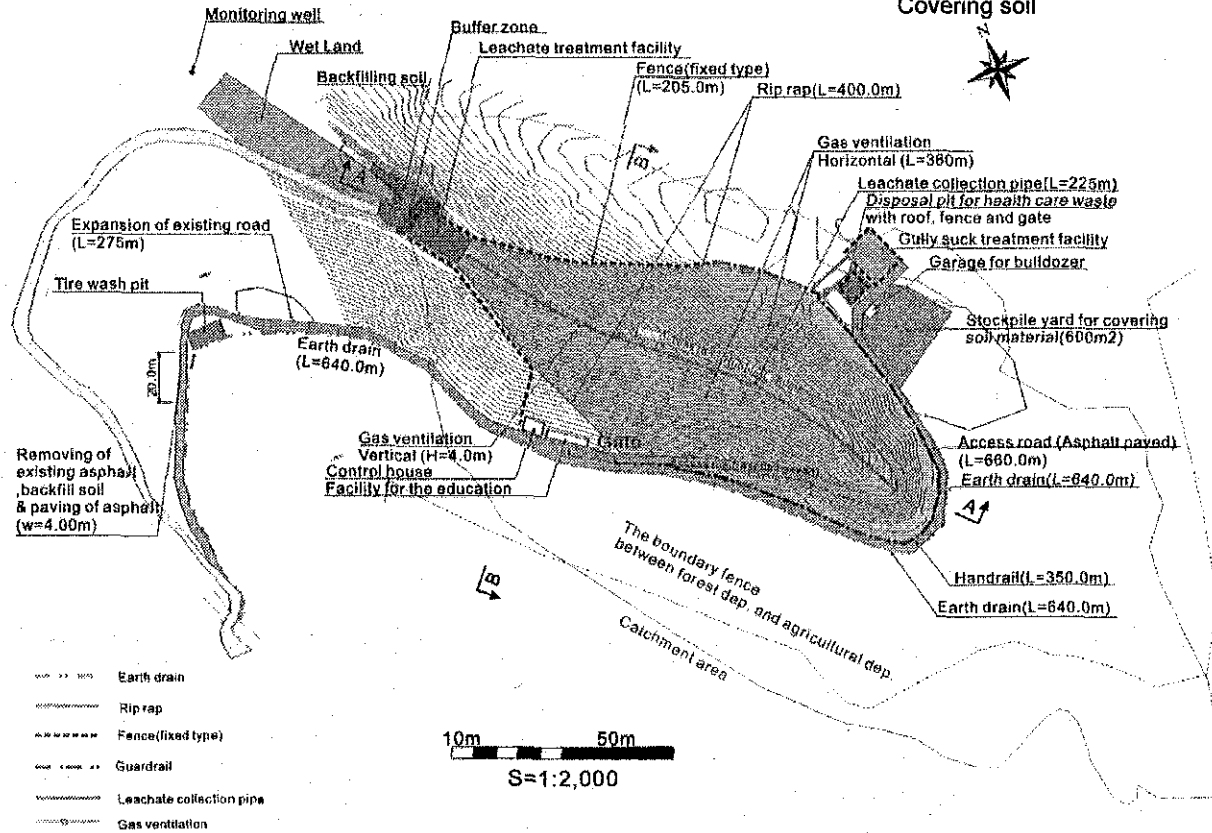

Leachate treatment facility

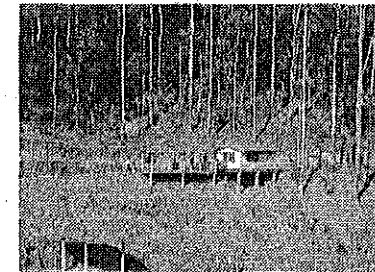

Control house & Education facility

H-9

Figure H.2-3: Layout Plan of Improved Landfill Site

## H.2.2 Nature of the project

### H.2.2.1 Landfill facility

#### a. Conceptual design of the landfill facility, extent capacity and life span

The landfill site design fully took account of the required mitigation measures identified at Chapter 5. Table 1 and Figure 3 shows the conceptual design of the improved Moon Plain Landfill Site. The extent capacity is 191,000m<sup>3</sup>, while the life span of improved Moon plain landfill site is approximately 20 years.

Table H.2-1: Conceptual Design of Improved Moon Plains Landfill Site

Item		unit	Qty
Total area of improved landfill site		ha	approx. 2.0
Extent Capacity		m <sup>3</sup>	191,000
Life span		years	20
Type of landfill method		-	Semi-Aerobic
Administration	Control office	no.	1
	Garage for bulldozer	no.	1
Education	Education facility for sanitary landfill	no.	1
Security and safety facility	Gate	no.	1
	Fence (Fixed type)	L.S.	1
	Handrail	L.S.	1
Sanitary waste disposal facility	Access road (asphalt paved) for long term use	L.S.	1
	Access road (gravel) for short term use	L.S.	1
	Fence (Movable type)	L.S.	1
Leachate collection facility		L.S.	1
Leachate treatment facility –Combine system which consists of coconuts fibre biological conductor, charcoal filter and wet land		no.	1
Gully sucker treatment facility		no.	1
Storm water drainage	Rip rap type along the waste filling slope	L.S.	1
	Earth drain type along the road	L.S.	1
Gas ventilation facility –Perforated oil barrel filled with rubble stone		nos.	10
Tire wash pit		no.	1
Disposal pit for infectious waste		no.	1
Monitoring well		no.	1

## **b. Leachate Collection System**

In order to minimize the deterioration of surface and ground water by leachate, all leachate generated from landfill operation has to be collected and to introduce it to the leachate treatment facility. The facility ordinary consists of the following components.

- Low permeable bottom liner
- Leachate collection pipe network

### **b.1 Low permeability of bottom layer**

The bottom layer must be enough low permeable in order to protect groundwater from infiltration of leachate into the ground. However, the provision of artificial liner is always the largest conflict in the construction cost. The best solution is, therefore, the full utilization of the natural condition. In order to examine whether natural ground can be utilized for the low permeable layer for the landfill site, the geological survey was conducted at the site in October 2002 in the Study. The result of geological survey is as follows. (refer to Appendix)

- 1) The upper strata above 1.0 to 3.7 metres below the ground is clay soil and weathered rock. Its permeability is about  $10^{-5}$  to  $10^{-6}$  cm/sec.
- 2) The lower strata below 1.0 to 3.7 metres below the ground is a bedrock strata which has sufficient low permeability.

Although the soil material of upper strata satisfy the required permeability of the landfill site, more reliable lower strata, rock mass, will be used as the impermeable layer for the landfill site.

In addition, as the geological survey recommended, wherever joints/discontinuities are found on rock mass during the excavation for the leachate collection pipe laying work, the clay will be filled into them and they will be covered by cement mortar in order to ensure it impermeable.

In order to utilize the lower strata as the low permeable layer, the leachate treatment facility will be constructed at the lowest point of the landfill disposal area in order to block all leachate flow and to introduce it to the leachate collection pipe.

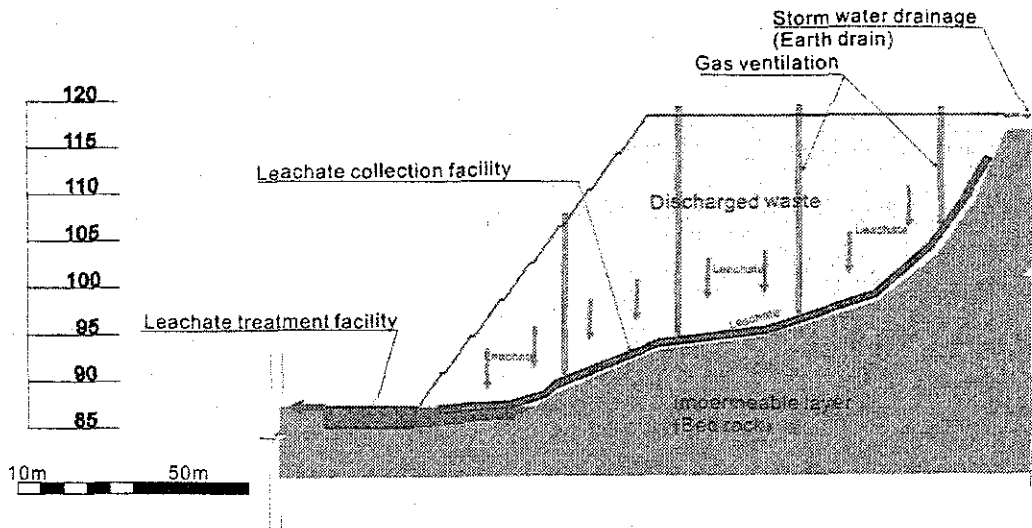

Figure H.2-4: Leachate Treatment Facility for Blocking Leachate

### b.2 Leachate collection pipe network

The leachate collection pipe network will be installed to achieve the following purposes.

- 1) To collect and to introduce leachate generate in the site to the leachate treatment facility.
- 2) To naturally supply air into the inside of landfill to accelerate the waste decomposition process.

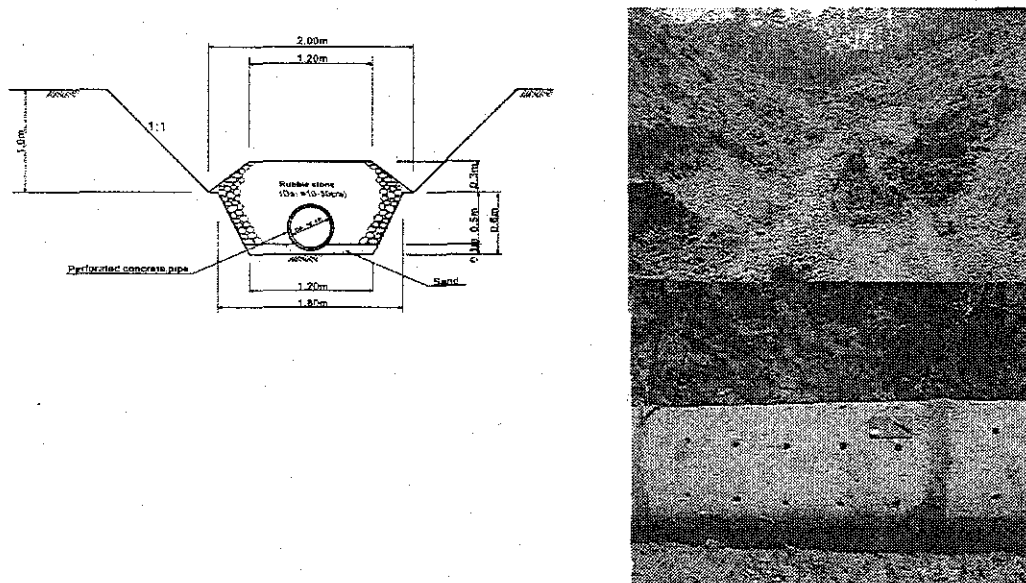

Figure H.2-5: Leachate Collection Facility

### c. Leachate Treatment process

The selection of the most suitable leachate treatment system for the site is very important in the project planning because there are many available systems which have different advantages and disadvantages. The following three points are mainly considered in the selection of the system.

- Required area

- Required technical skill for the operation
- Required operation and maintenance cost

Table H.2-2: showing the comparison of the suitability of five common methods for the site resulted that the combine system which consist of coconuts fibre biological conductor, charcoal filter and wet land is the most suitable for this site.

Final treated effluent will be discharged to the perennial stream through wet land.

Table H.2-2: Comparison of Leachate Treatment Methods for the Moon Plain landfill site

	Activated Sludge system	Aerobic Pond System	Rotating Biological Contactor System	Recirculation System	Combine system which consist of coconuts fibre biological conductor, charcoal filter and wet land
Description	The activated process is a continuous-flow, aerobic biological process for the treatment of domestic and biodegradable industrial wastewaters. The process provides a high-quality effluent and is characterized by the suspension of microorganisms, which are maintained in a relatively homogeneous state with the wastewater by mixing induced by the aeration system. The overall treatment process will include preliminary, and often primary, treatment before the aeration basin(s). The mixed liquor is discharged to a secondary clarifier where the microorganisms settle out and are recycled to the aeration basin. Excess sludge is piped to separate sludge-handling processes. The clarifier overflow proceeds to disinfection and final discharge or to supplemental treatment, if required.	Historically, aerobic wastewater stabilization pond systems have been a principal biological treatment method for a variety of wastewaters ranging from residential domestic to complex industrial. They may be used alone or in combination with other treatment processes. The advent of aeration via mechanical sources added yet a broader use of pond systems.  The three principle types of aerobic ponds are 1. Aerobic 2. Facultative 3. Aerated  Furthermore, pond systems are characterized hydraulically as discharge, controlled discharge or retention (no discharge to surface waters).	A rotating biological contactor (RBC) is an attached-growth process wherein the media are rotated through a basin of wastewater. The microorganisms are attached to large-diameter synthetic mounted on a horizontal shaft and placed at about 40% submergence in a contoured-bottom tank. Generally, the media are some 10 to 12 ft (3-3.5 m) in diameter and rotate at a peripheral velocity of 60 ft/min (0.3 m/s).  The preferred temperature range for an RBC system is 55 to 90°F (13 to 32°C). Thus, in colder climates the units are enclosed for climatic control.	The process of recirculation is as follows. 1. Leachate collection by perforated pipe at the landfill site 2. Retention of leachate at a pond 3. Pumping up leachate for landfill site 4. Distribution of leachate at the landfill site  The leachate is treated by contacting with waste and evaporated through the recirculation process. <b>Advantages:</b> 1. The process of landfill stabilisation is accelerated 2. The constituents of the leachate are attenuated by biological, chemical and physical changes occurring with the landfill. <b>Disadvantages:</b> 1. Not applicable for the area having low evaporation 2. Poor operation makes the disposal area muddy and inaccessible.	The coconut fibre biological contactor system is a continuous-flow, Anaerobic biological process for the treatment of domestic and biodegradable industrial wastewaters. The system is introduced by the Rubber Research Institute of Sri Lanka for rubber effluent treatment but applicable to any biodegradable wastewater. The special arrangement of Coconut fibre is called Bio-Brush that gives the structural stability to hold the thrust of biomass accumulation and gas formation on surface of fibre, leaving enough void space for releasing gas and mixing of hydraulic flow. To increase the overall efficiency of the treatment system, the treated wastewater is further purified through a Charcoal filter followed by a Constructed Wetland. The system operates with gravity flow without any moving parts consequently minimum maintenance requirement.
Required technical skill for operation	High degree of technical skill required.	A simple technical skill required.	A simple technical skill is required.	A simple technical skill is required.	A simple technical skill required.
O&M cost	Very expensive	Cheap	Expensive (material can not obtain in Sri Lanka)	Cheap	Cheap
Area for leachate treatment facility	Enough for the facility. The area for the facility of activated sludge system is required less than 250m <sup>2</sup> which can be available.	Not enough for the facility. The area for the facility of aerobic pond system is required more than 250m <sup>2</sup> which can be available.	Enough for the facility. The area for the facility of RBC system is required less than 250m <sup>2</sup> which can be available.	Enough for the facility. The area for the facility of recirculation system is required less than 250m <sup>2</sup> which can be available.	Enough for the facility. The area for the facility of the system is required less than 250m <sup>2</sup> which can be available.
Evaluation of treatment	It is too difficult for Nuwara Eliya MC to operate the treatment facility with a high degree of technical skill due to lack of engineer. In addition the equired O&M cost is too expensive	The area for treatment facility at the Moon Plain landfill site is not enough for the facility of aerobic pond system	It is difficult for Nuwara Eliya MC to maintain the treatment facility because rotated disk can not obtained in Sri Lanka, when it is required to replace.	Recirculation system is not suitable at Nuwara Eliya due to quite low evaporation and high precipitation.	The land area and operation technology is simple and cheap. Therefore it is easy to operate and maintained the system with locally available materials and technical knowledge.
Result	Not suitable	Not suitable	Not suitable	Not suitable	Very suitable



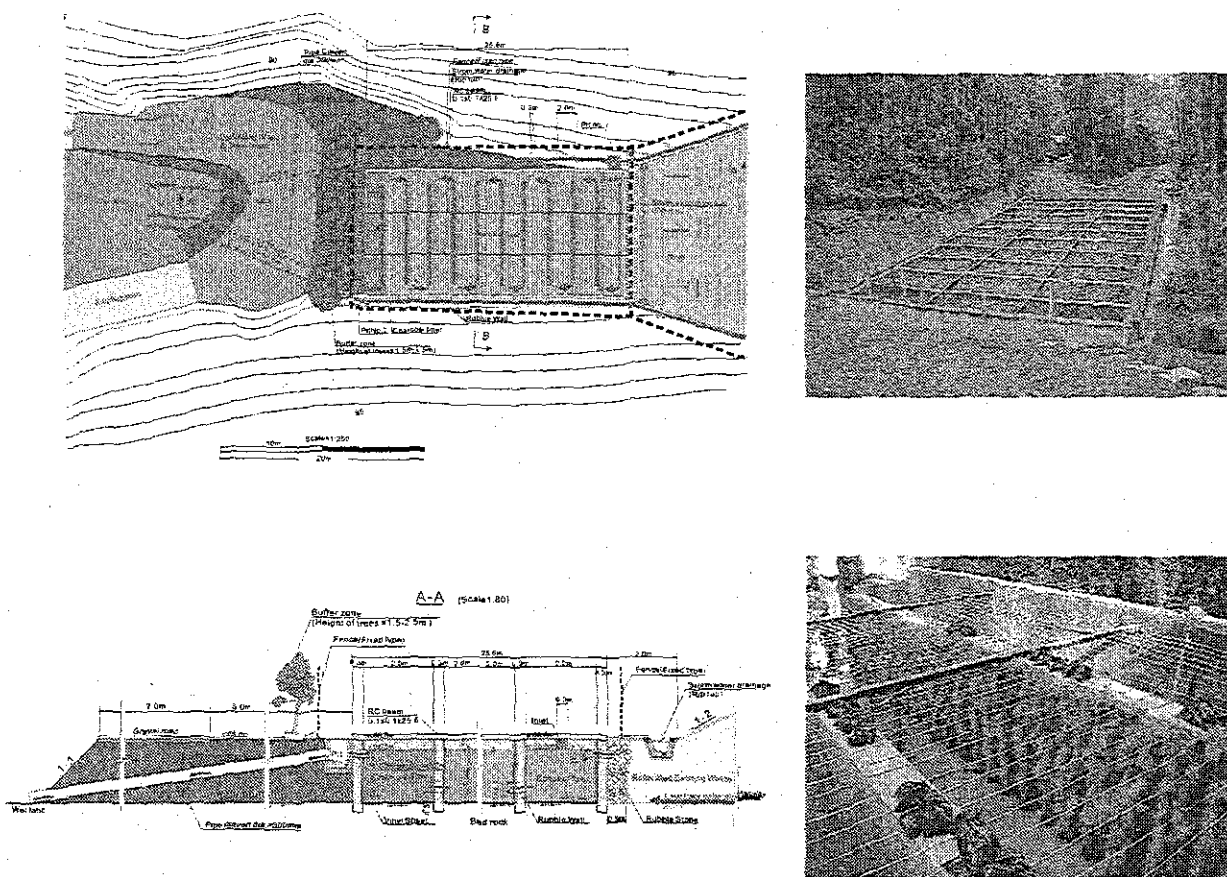

Figure H.2-6: Leachate Treatment Facility

**d. Details of any other structure**

**d.1 Bench (terrace)**

The purpose of bench is as follows.

- 1) To protect the slope by intercepting runoff water flowing on the slope.
- 2) To provide the enough space for the interceptor drain on berms.
- 3) To provide the enough working space for the slope maintenance.
- 4) To keep the waste filling slope stable.

The bench plan is as follows.

- Every 4 meters in height.
- 2 meters in bench width.

The purpose of leachate collection facility on the bench was to collect seeping leachate from the relocated landfill site.

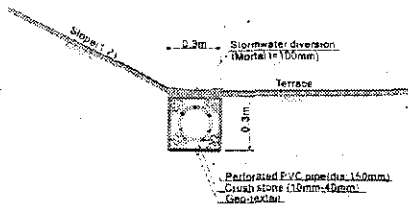

### d.2 Turfing

The outside of slope of the waste filling will be turfing for the following purposes.

- 1) Protection of the slope from erosion by runoff water.
- 2) Maintenance of the good view.



### d.3 Fence (movable type)

The movable fence will be placed depending on the landfill operation for prevention of waste scattered to outside of the site.

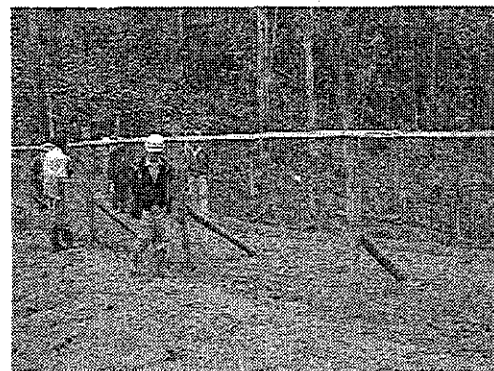
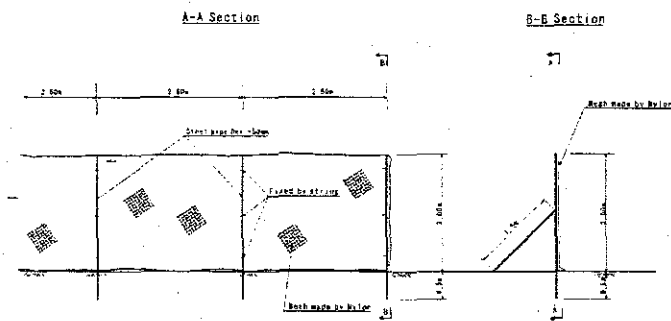

Figure H.2-7: Fence (movable type)

#### d.4 Storm water Drain

The storm water drain will be installed for the following purposes.

- 1) Minimization of leachate generation amount by intercepting runoff water into the site.
- 2) Maintenance of access road
- 3) Provision of a guide for the landfill slope.

The earth drain will be provided along the access road to intercept all runoff from the outside of the access road.

Riprap lined drain will be provided along the slope of the waste filling area.

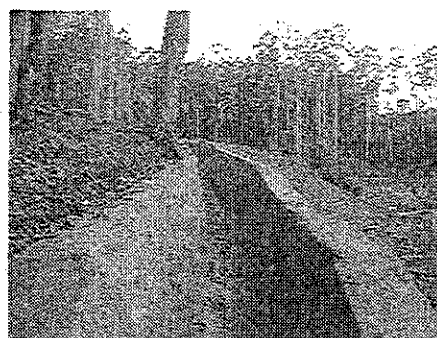
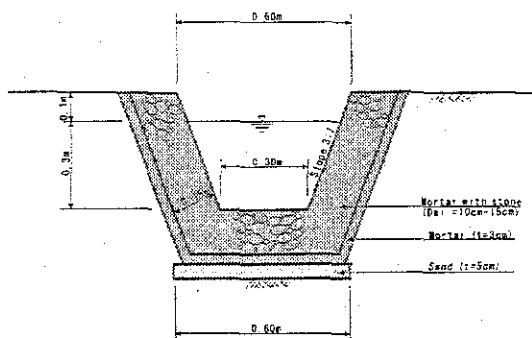

Figure H.2-8: Riprap Lined Storm water Drain

#### d.5 Gas Ventilating Facility

The gas ventilating facility will be provided for the following purposes.

- 1) Exhaust landfill gas generated in the landfilled waste to minimize the risk of gas explosion
- 2) Acceleration of waste decomposition process with supplying air into the landfilled waste through gas ventilating facility (semi-aerobic type)

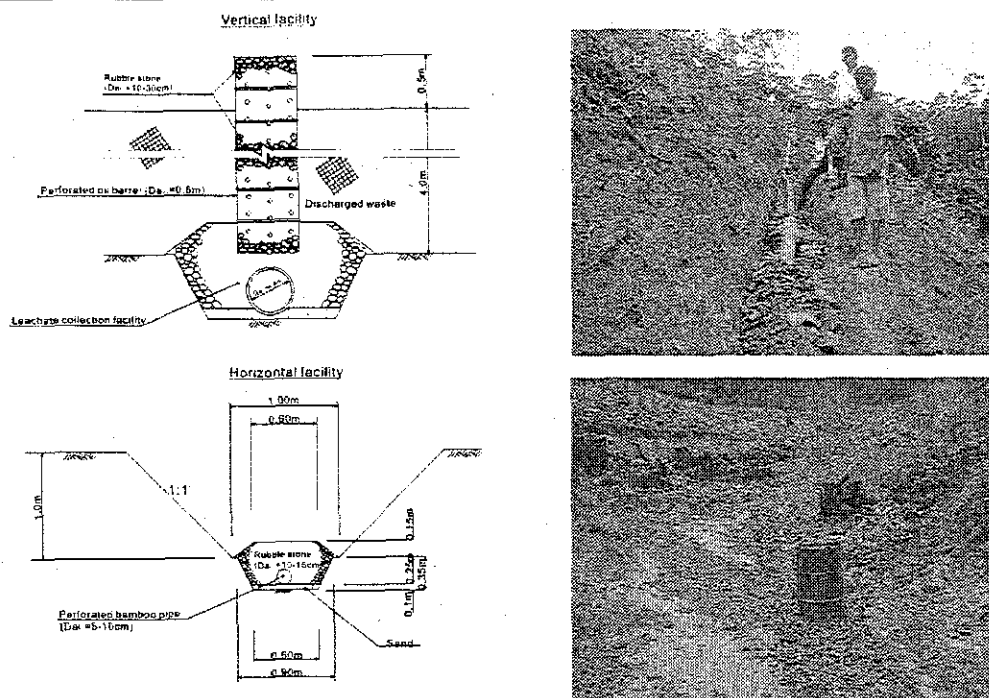

Figure H.2-9: Gas Venting Facility

#### d.6 Disposal Pit for Healthcare Waste

The disposal pit for healthcare waste will be constructed separately. It receives the following wastes which require special care for handling.

- Syringes
- Medical tools and goods which contacted blood

The above mentioned medical waste will be collected by plastic bag. And those will be transported to the disposal pit for health care waste from the hospital at Nuwara Eliya directly. When the collectors handle those wastes, they have to put gloves for the safety.

The disposal pit will be completely surrounded by a gate and a fence to ensure nobody except the landfill staff can enter.

In order to avoid the leachate generation from healthcare waste, the following facilities to avoid the entry of runoff water into the site will be provided.

- 1) A roof to cover the whole disposal pit
- 2) Drain surrounding the whole disposal pit to intercept the runoff water.

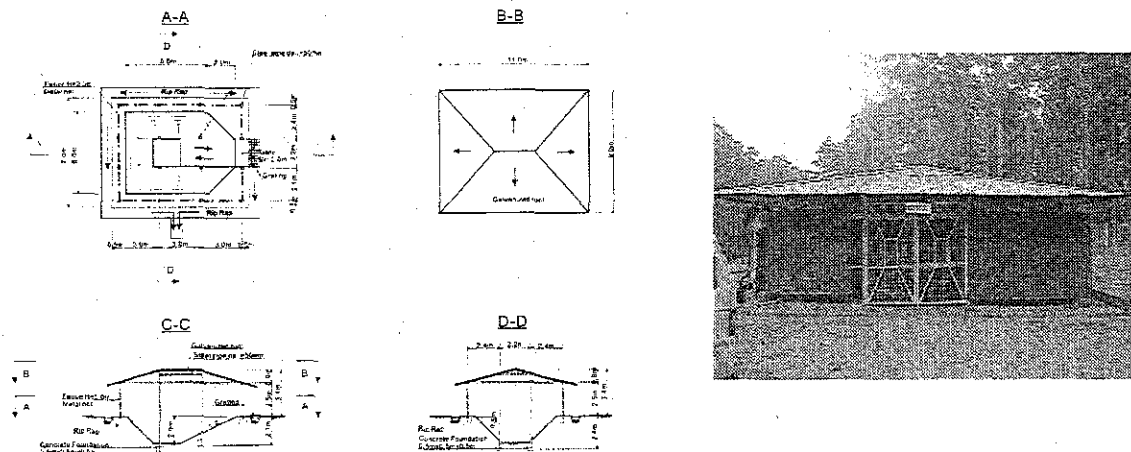

Figure H.2-10: Disposal Pit for Healthcare Waste

#### d.7 Tire Wash Pit

Tire of collection vehicle is washed in order to prevent litter the waste or mud, attached to the collection vehicle.

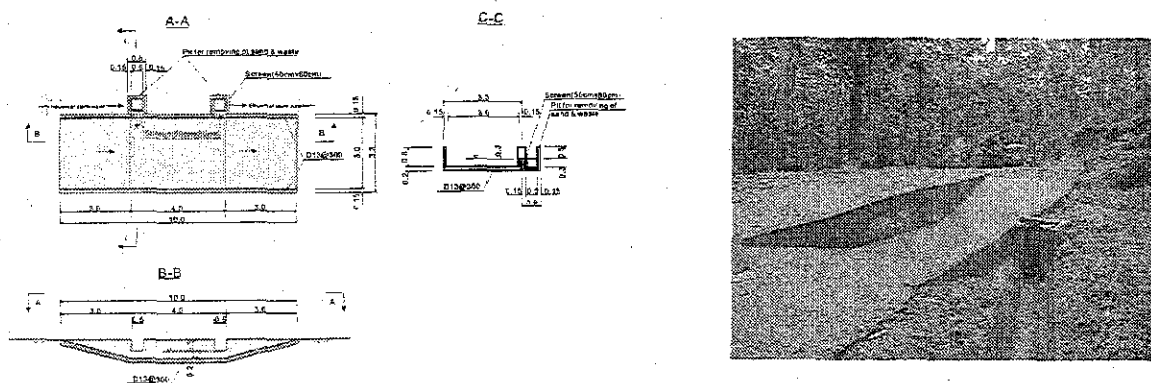

Figure H.2-11: Tire Wash Pit

#### d.8 Gully suck treatment facility

The gully sucker treatment facility will be constructed separately. It receives the gully suck comes from Nuwara Eliya town periodically.

The gully suck treatment facility consists of sedimentation tanks and the coconuts fibre biological conductor. Final treated effluent will be discharged to the perennial stream through storm water drainage and wet land.

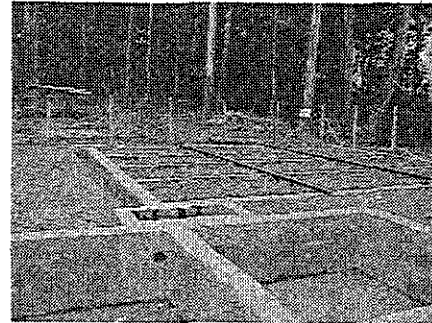
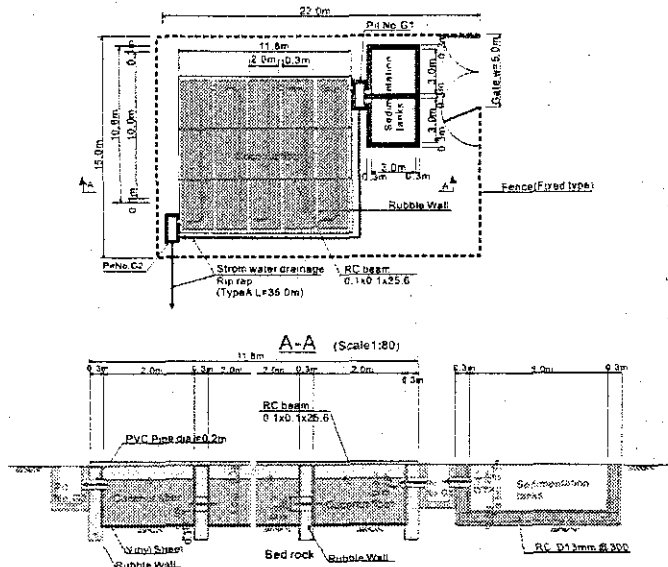

Figure H.2-12: Gully Suck Facility

### H.2.2.2 Other support facilities

#### a. Administrative Facilities

- 1) A site office will be built to provide a proper space for administrative work, rest space, and sanitary facility for employees in the landfill site.
- 2) A store house will be built to keep tools, materials, safety goods, etc.
- 3) A garage for a bulldozer will be built to secure and to protect a bulldozer.

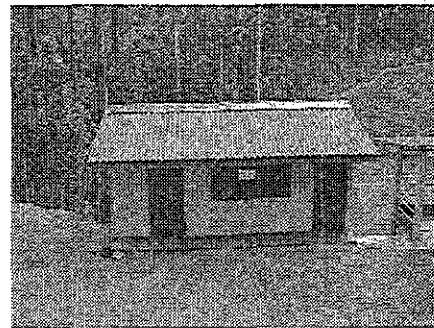
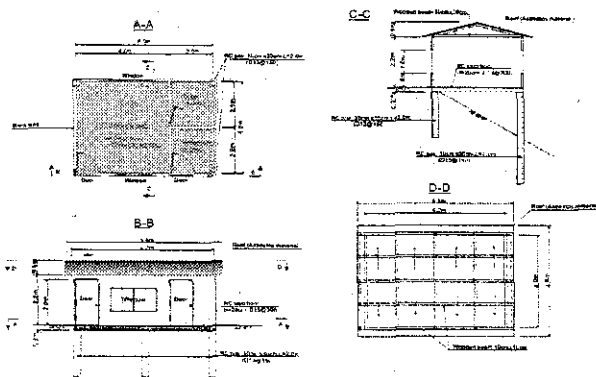

Figure H.2-13: Administrative Facilities

#### b. Education Facility for Sanitary Landfill Method

The education facility to teach the sanitary landfill method to visitors will be installed, because this landfill site will be the model sanitary landfill site. The education items are as follows.

- 1) Pictures before and after the improvement
- 2) Overall plan showing the purpose of each facility
- 3) Some of typical leachate collection systems including the interceptor drain
- 4) Some of typical leachate treatment systems

- 5) Some of typical gas ventilation facilities
- 6) Landfill layer plan
- 7) Cell landfill method

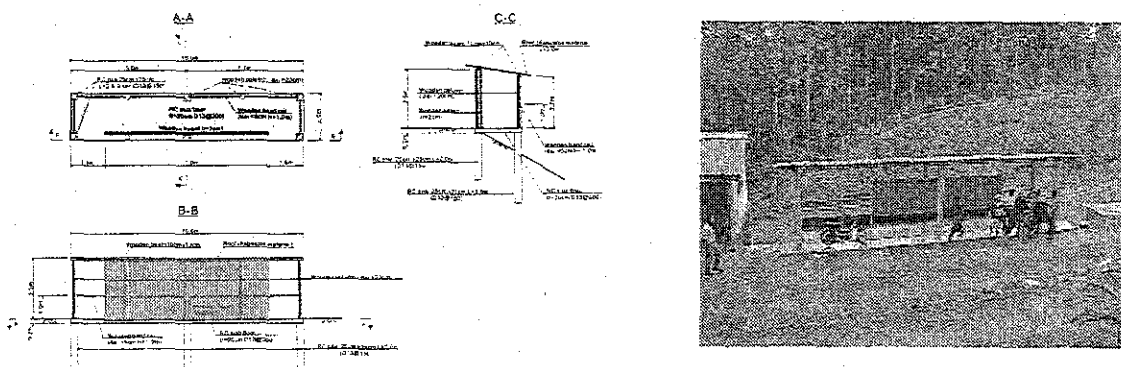

Figure H.2-14: Education Facility for Sanitary Landfill Method

**c. Security and Safety Facilities**

**c.1 Security facilities**

A gate and fences will be constructed to control the entry to the site. Fences will function as the waste scattering net as well.

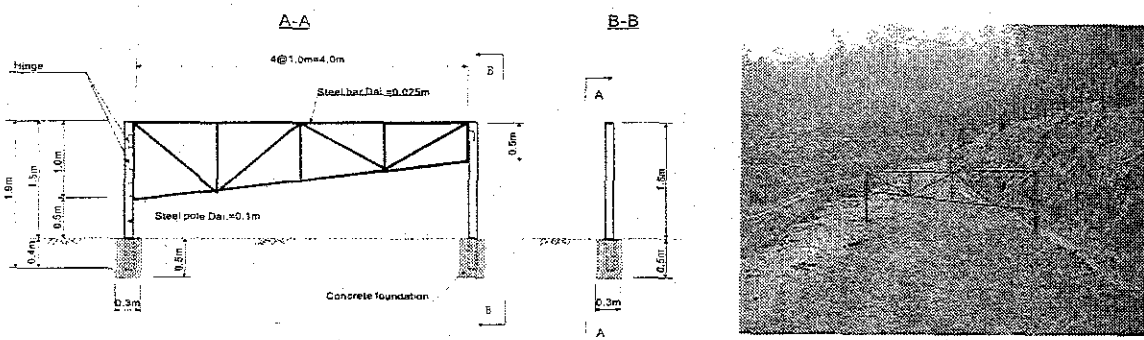

Figure H.2-15: Gate

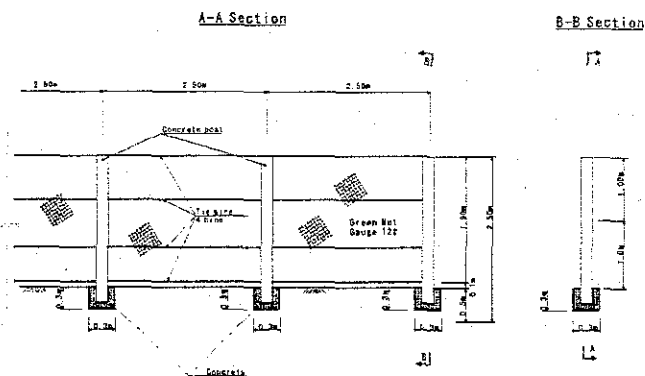

Figure H.2-16: Fence (fixed type)

**d. Safety facility**

Handrails will be provided to protect people from falling down from the top of slope to the disposal area.

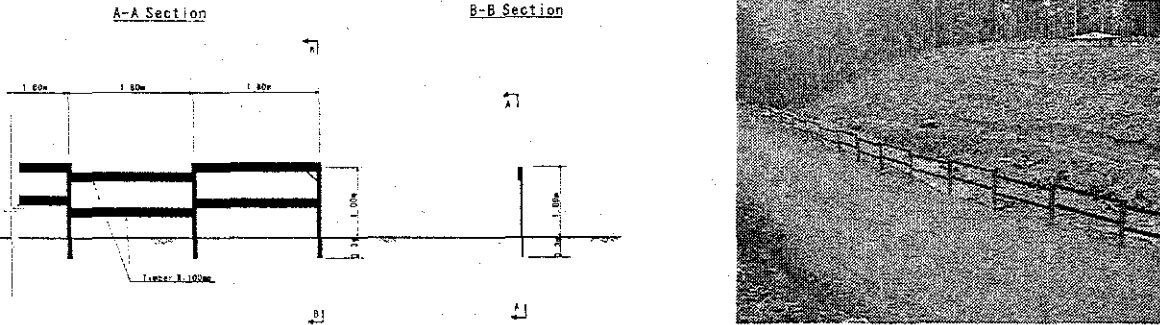

Figure H.2-17: Handrail

**H.2.2.3 Construction of new roads and/or improvement of existing road**

New access road at the improved landfill site will be constructed and the width of existing road will be extended in order to operation the sanitary landfill. The location of new road and extended road are shown in Figure 3. Any new access roads between the landfill site and the Nwara Eliya town will not be constructed.

**a. Access road**

Provision of a good access road is very important for landfilling operation because many waste collection vehicles have to access to a disposal area even on wet days. Because Nuwara Eliya has more than 250 wet days annually, the provision of good access road is essential to ensure the good waste collection efficiency. In addition, good access road will help to prolong the life year of waste collection vehicles and to reduce the repairing cost.

In this project, the following two types of access roads depending on the durations to be utilized will be provided.

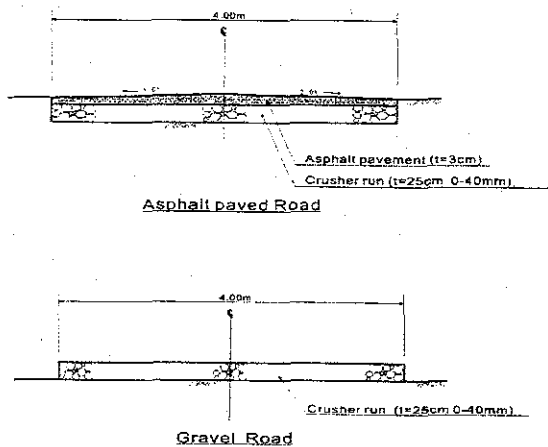

Figure H.2-18: Typical Cross Section of Access Road



#### H.2.2.4 Transfer station

None.

#### H.2.2.5 Offsite infrastructure facilities and services required

None.

#### H.2.2.6 Details of phased development activities and time schedule

This project is planned to be implemented with the cooperation of JICA Study Team subject to the JICA's approval. JICA's cooperation is planned to cover the following tasks.

Table H.2-3: Proposed Implementation System

Stage	Nuwara Eliya Municipal Council	JICA Study Team
Planning works	1) Provision of required data	1) Field surveys 2) Initial environmental impact assessment 3) preparation of the improvement plan.
Preparation works	1) Obtaining all required approvals from <ul style="list-style-type: none"> <li>• relevant authorities,</li> <li>• neighbourhoods and</li> <li>• municipal council</li> </ul> 2) Allocation of the enough budget for the works to be done by NEMC 3) Allocation of the enough human resources to execute the proper landfill operation.	1) Technical assistance
Construction works	1) Cutting all trees and removing roots within the construction site	1) Construction of following facilities: <ul style="list-style-type: none"> <li>• Drainage system</li> <li>• Leachate collection system</li> <li>• Leachate treatment system</li> <li>• Gas ventilation system</li> <li>• Access road</li> <li>• Security facilities</li> <li>• Waste scattering prevention net fence</li> <li>• Construction of secured disposal area for health care waste</li> </ul>
Operation & maintenance works	1) Execution of the landfill operation in accordance with the landfill operation manual prepared by the JICA Study Team	1) Preparation of the operation manual for the sanitary landfill 2) Provision of on the job training
Monitoring work	1) Establishment of the monitoring committee 2) Implementation of the periodical monitoring by the monitoring committee in accordance with the procedure prepared by the JICA study Team	1) Preparation of the monitoring check list. 2)

Figure H.2-19 shows the proposed implementation schedule for the improvement project.

	Year Month		2002			2003									
			Oct	Nov	Dec	Jan	Feb	Mar	Apr	May	Jun	July	Aug	Sep	Oct
			1 Planning work												
1.1	Field survey	JICA	■												
1.2	Environmental consideration & Planning	JICA		■											
1.3	Preparation of the study report	JICA	■												
2 Preparation work															
2.1	Approval from municipal council	NE		■											
2.2	Approval from relevant authorities	NE		■	■	■	■	■	■	■	■	■	■	■	■
2.3	Approval neighbourhoods	NE		■	■	■	■	■	■	■	■	■	■	■	■
2.4	Allocation of budget for the operation	NE		■	■										
2.5	Financial arrangement for the investment	JICA						■	■	■					
3 Construction work															
3.1	Cutting trees	NE										■	■		
3.2	Construction of facilities	JICA										■	■	■	■
4 Operation work															
4.1	Preparation of the operation manual	JICA													■
4.2	Provision of on-the-job training	JICA													■
4.3	Implementation of the proper operation	NE													■
5 Monitoring work															
5.1	Establishment of the monitoring committee							△							
5.2	Execution of the monitoring										△				△

Figure H.2-19: Proposed Implementation Schedule

**H.2.2.7 Details of site restoration and potential after use**

The landfill site will have been used for approximately 20 years. Therefore, the detailed site restoration and potential shall be designed in the future. The samples of site restoration are such as “play ground” and “Eco Park” etc

**H.2.3 Sources, Quantity, Quality and pre-processing of waste**

Figure H.2-20: Sources, Quantity Quality of Waste shows the sources, quantity and quality of waste generated at Nuwara Eliya. While

Table H.2-4: shows the waste physical composition and approximate collection amount in Nuwara Eliya.

The waste collection amount is as follows.

- 20 T/day except April when many visitors come.
- 600 T/month
- 7,300 T/year

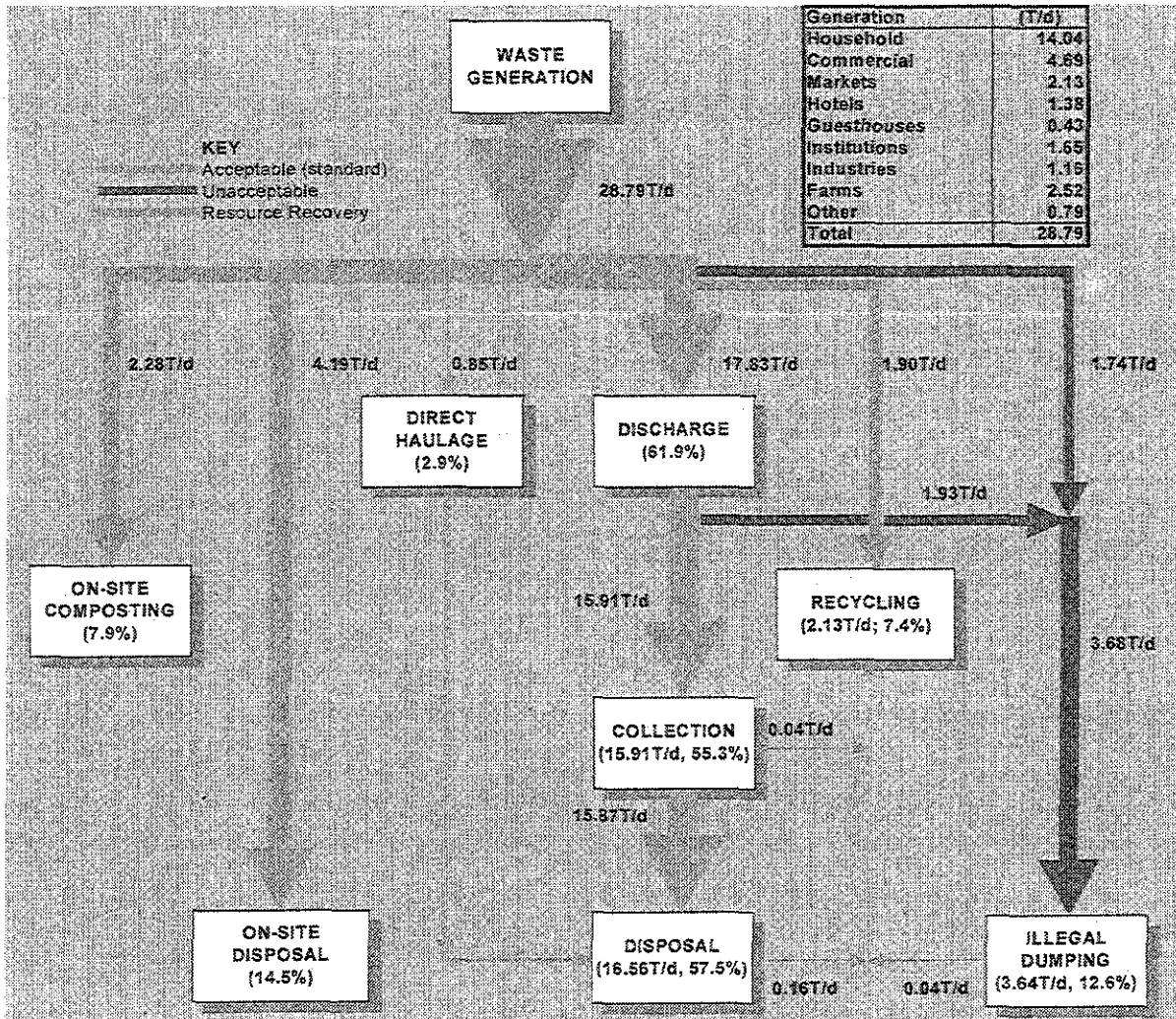

Figure H.2-20: Sources, Quantity Quality of Waste

Table H.2-4: Waste Physical Composition and Approximate Amount in Nuwara Eliya

Category	Ratio	Approximate Amount
Kitchen waste	71.6 %	14.3 T/d
Grass & wood	5.7 %	1.1 T/d
Paper	11.1 %	2.2 T/d
Textile	1.2 %	0.2 T/d
Soft plastic	5.4 %	1.1 T/d
Hard plastic	0.3 %	0.1 T/d
Leather & rubber	0.1 %	0.0 T/d
Metal	0.7 %	0.1 T/d
Glass	0.9 %	0.2 T/d
Ceramic & stone	2.7 %	0.5 T/d
Others	0.3 %	0.1 T/d
Total	100.0 %	20.0 T/d

Note: Surveyed by the JICA Study Team in September 2002

This survey data implies the followings in terms of the appropriate waste final disposal measure.

There is no pre-processing activity of waste at Nuwara Eliya.

#### H.2.4 Waste collection system and transportation

The following systems are dominant at present and it is acceptable.

- Primary collection:..... Handcart collection
- Secondary collection: Tractor-trailer collection or compactor collection

The actual cost of the handcart collection system accounts for the majority of SWM cost because it is very inefficient and expensive.

As for the secondary collection, the transportation efficiency of tractor-trailers is quite good due to the heavy bulk density of existing waste. As shown below table, the actual transportation amount of waste per trip by a 6 m<sup>3</sup> tractor-trailer is almost the same as that of a 4 m<sup>3</sup> compactor. Therefore, there is not always an urgent need to introduce compactors because the present heavy bulk density of waste offsets the advantage of compactor's compaction effect.

Table H.2-5: Actual Transportation Amount of Waste by Different Collection Vehicle

Type of vehicles	Capacity	Actual transportation amount of waste
4WT tractor and trailer	6.26m <sup>3</sup>	2.428 ton/trip
Small Compactor	4.00m <sup>3</sup>	2.435 ton/trip
Large Compactor	8.00m <sup>3</sup>	4.011 ton/trip

However, the need for compactors is increasing due to the following reasons:

- The work of loading waste onto a trailer is one of the causes of the high absentee rate for waste collection workers because it is very hard.

- Criticism on leakage of leachate and scattering of waste from waste trailers is increasing.
- The increase of traffic congestion requires the collection work to be quicker.

Principal haulage routes is the existing access road and no there is other alternatives.

## **H.2.5 Methodology of Construction**

### **H.2.5.1 Details of land preparation activity (to be done by NEMC)**

The location and area of acquisition and logging to be required is as follows.

- Area A: Land acquisition, logging and removing of roots to be required
  - Area A=15,400m<sup>2</sup>
  - Leachate collection pipe at the "Area B"=135m
- Area B: Land acquisition and logging to be required=3,300m<sup>2</sup>
- Area C: Land acquisition to be required=550m<sup>2</sup>
- Land acquisition for the access road to be required=570m
- Land acquisition and removing of roots to be required for earth drain=640m

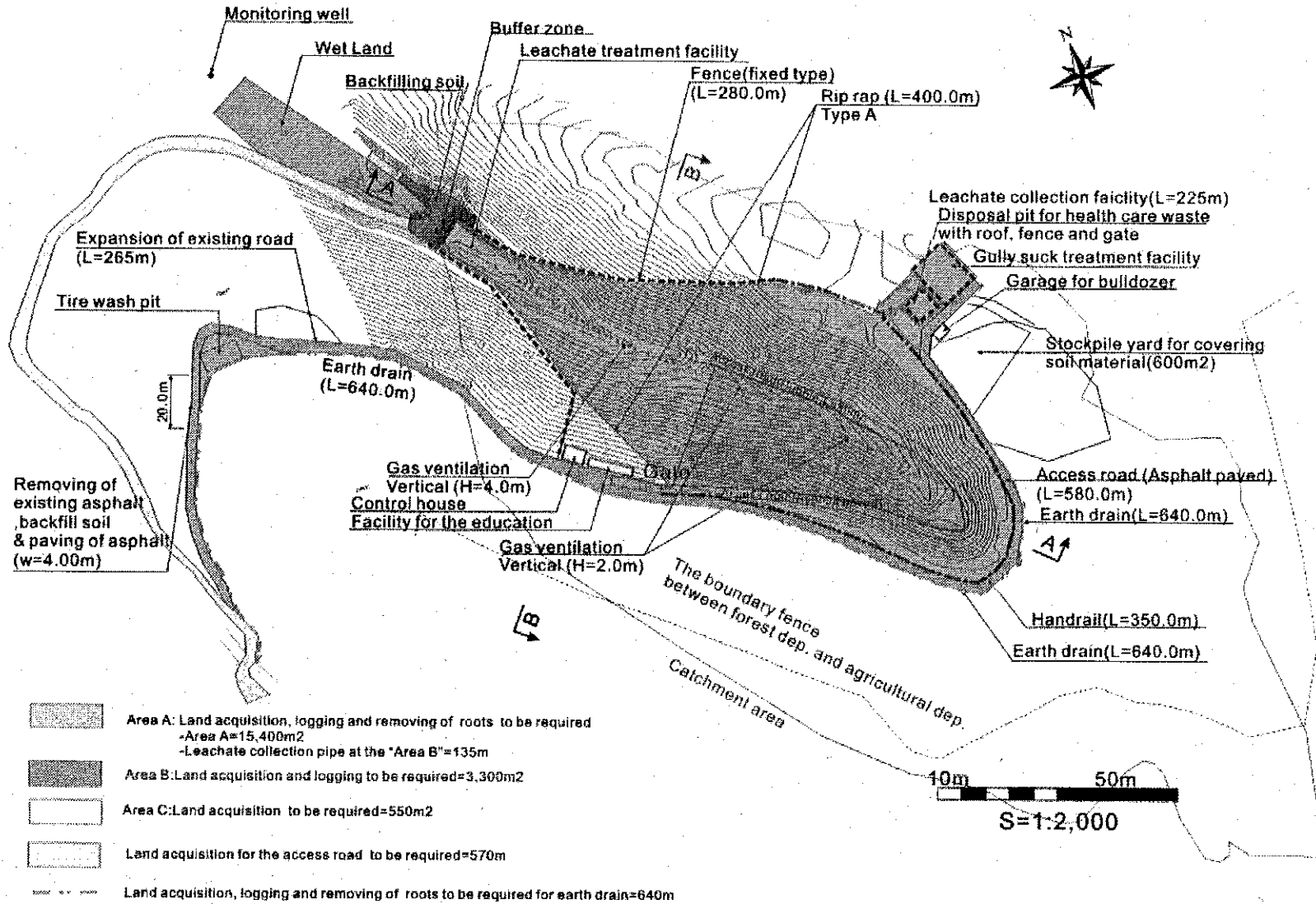

Figure H.2-21: Site Clearing Area