

Bang Giang - Ky Cung River Basin

Catchment Area : 11,250 km²

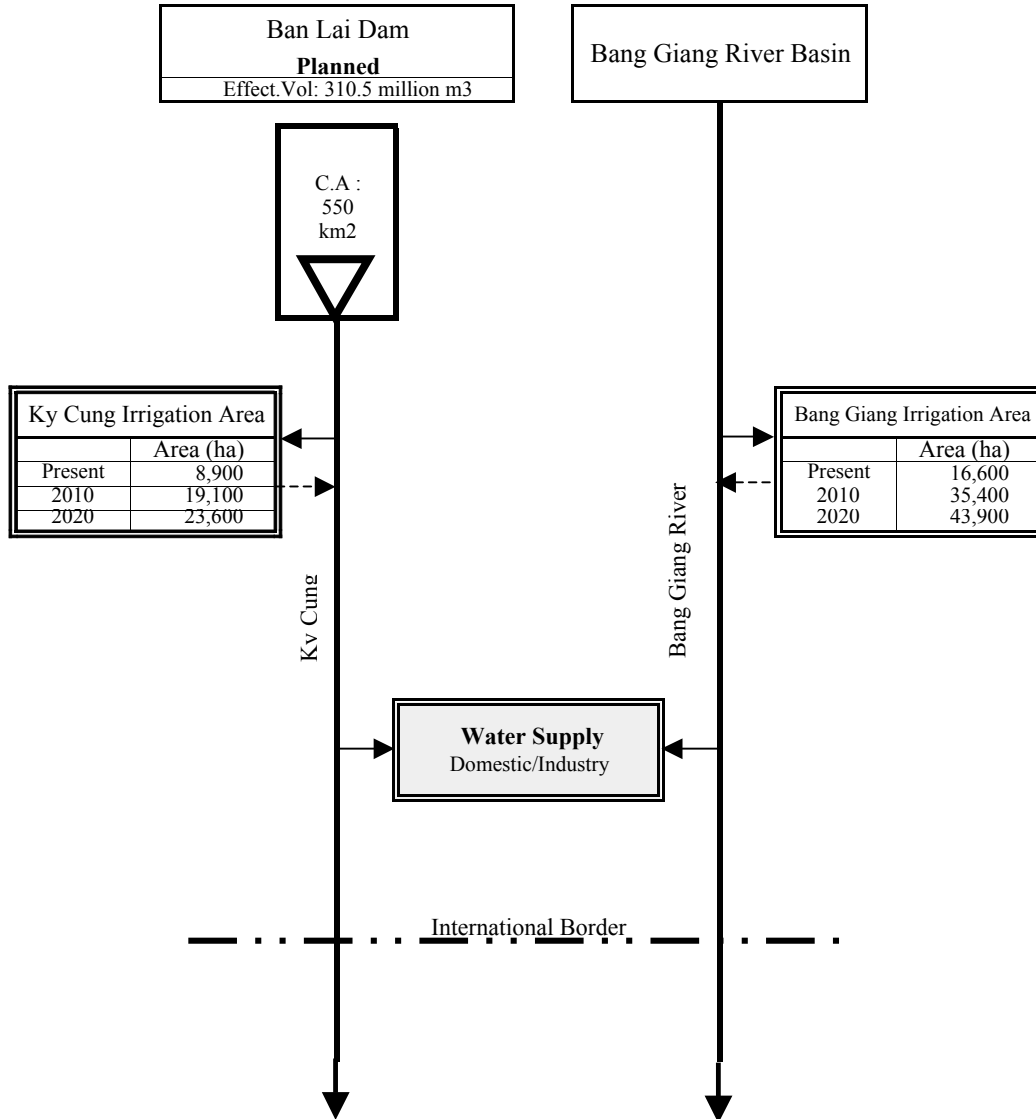

The Study on Nationwide Water Resources
Development and Management in the Socialist
Republic of Vietnam

JAPAN INTERNATIONAL COOPERATION

Hình 7.1

**Mô hình sơ đồ cân bằng nước
(Lưu vực sông Bằng Giang & Kỳ Cùng)**

Red and Thai Binh River River Basin

Catchment Area : 169,040 km²

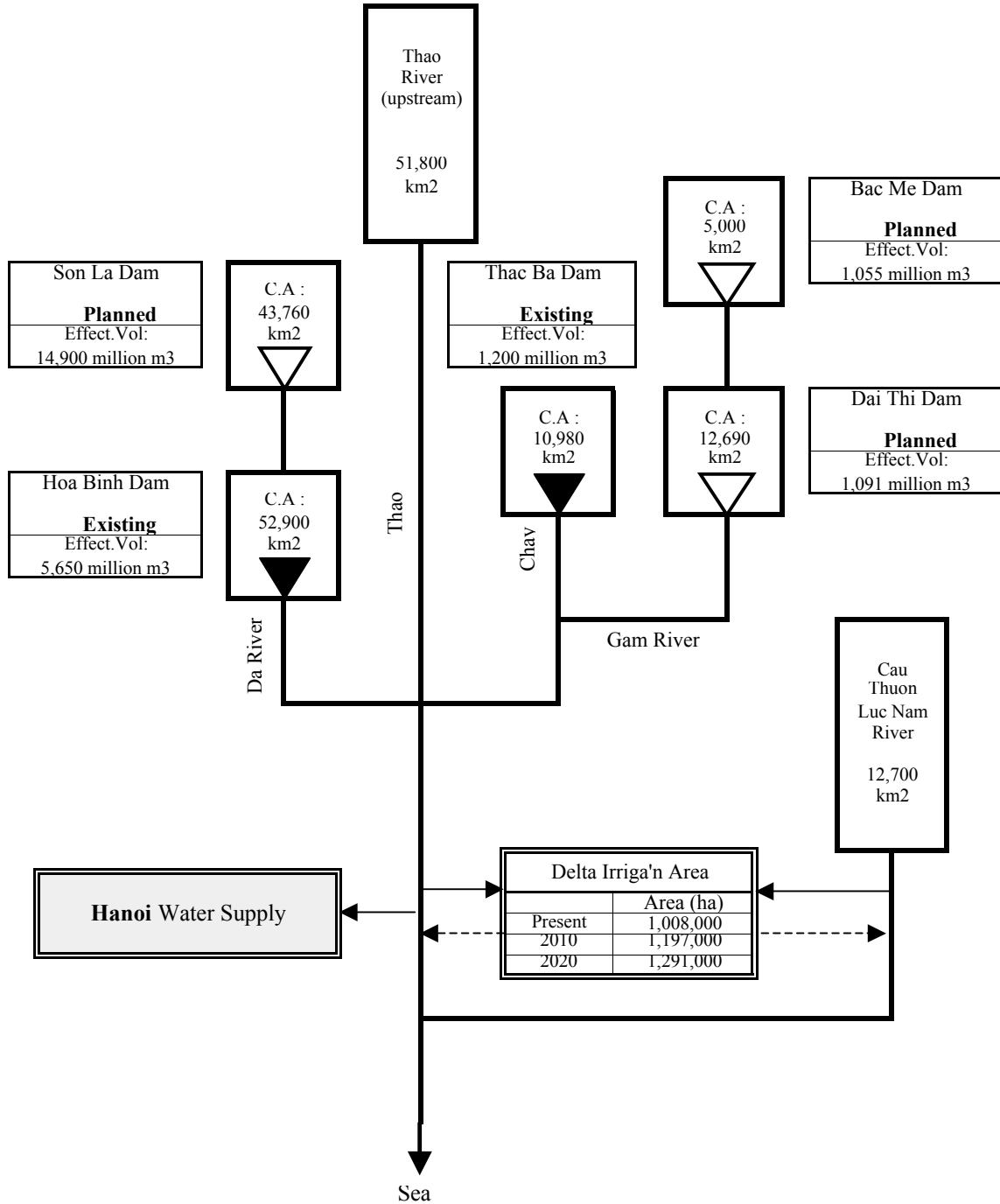

The Study on Nationwide Water Resources Development and Management in the Socialist Republic of Vietnam

JAPAN INTERNATIONAL COOPERATION

Hình 7.2

Mô hình sơ đồ cân bằng nước (Lưu vực sông Hồng và Thái Bình)

Ma River Basin

Catchment Area : 31,0600 km²

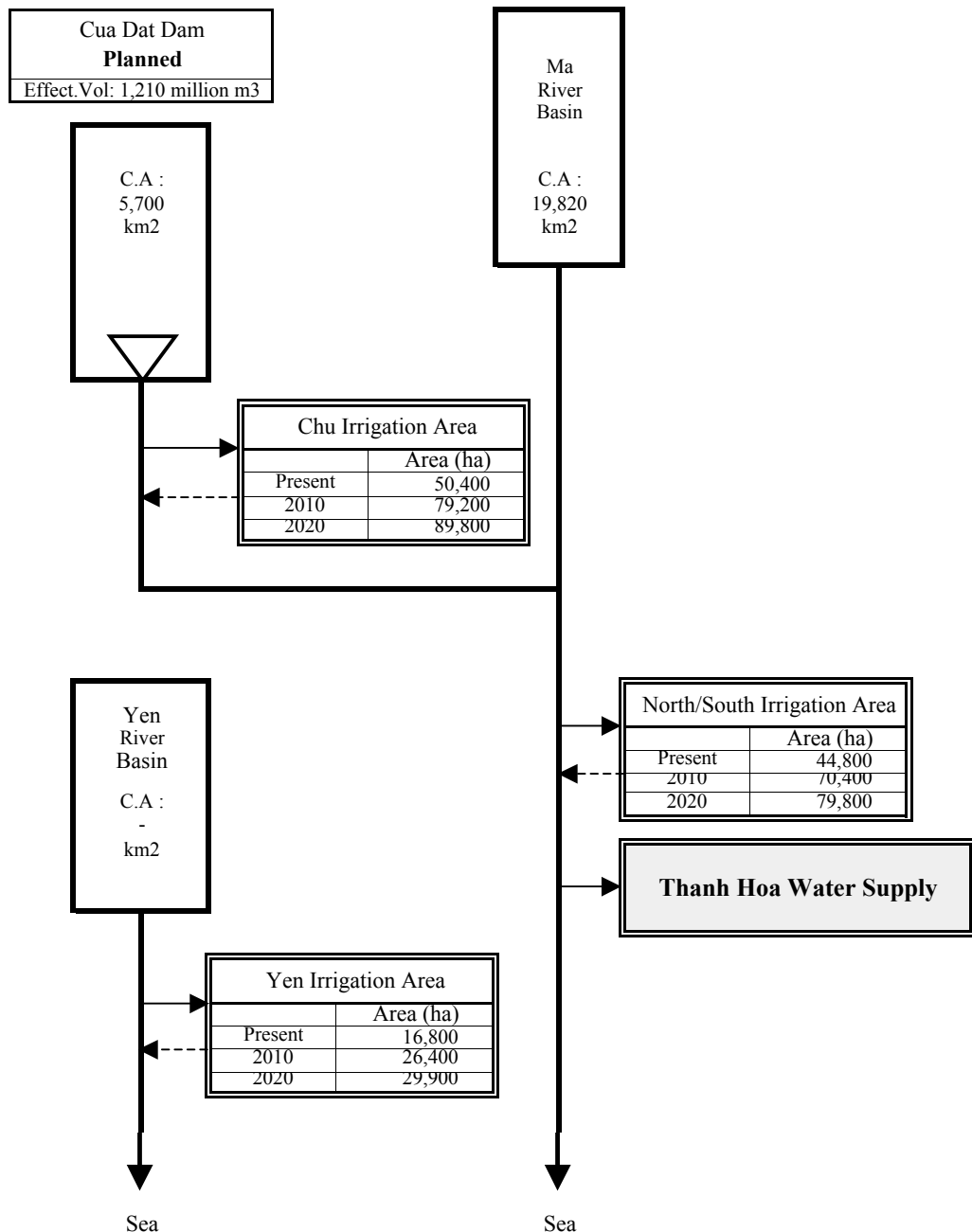

The Study on Nationwide Water Resources Development and Management in the Socialist Republic of Vietnam
JAPAN INTERNATIONAL COOPERATION

Hình 7.3
Mô hình sơ đồ cân bằng nước
(Lưu vực sông Mã)

Ca River Basin

Catchment Area : 29,850 km²

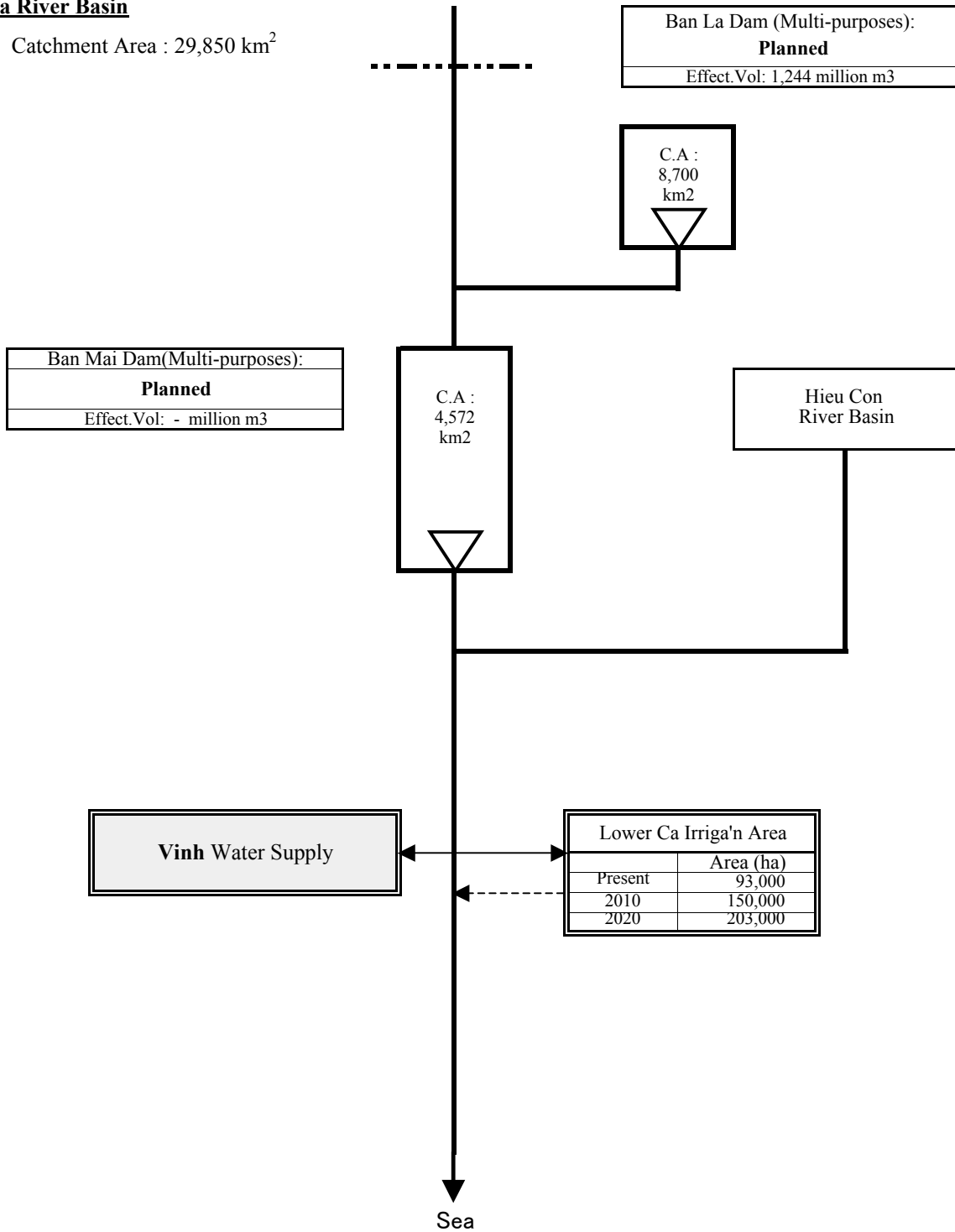

The Study on Nationwide Water Resources
Development and Management in the Socialist
Republic of Vietnam

JAPAN INTERNATIONAL COOPERATION

Hình 7.4

**Mô hình sơ đồ cân bằng nước
(Lưu vực sông Cả)**

Thach Han River Basin

Catchment Area : 2,550 km²

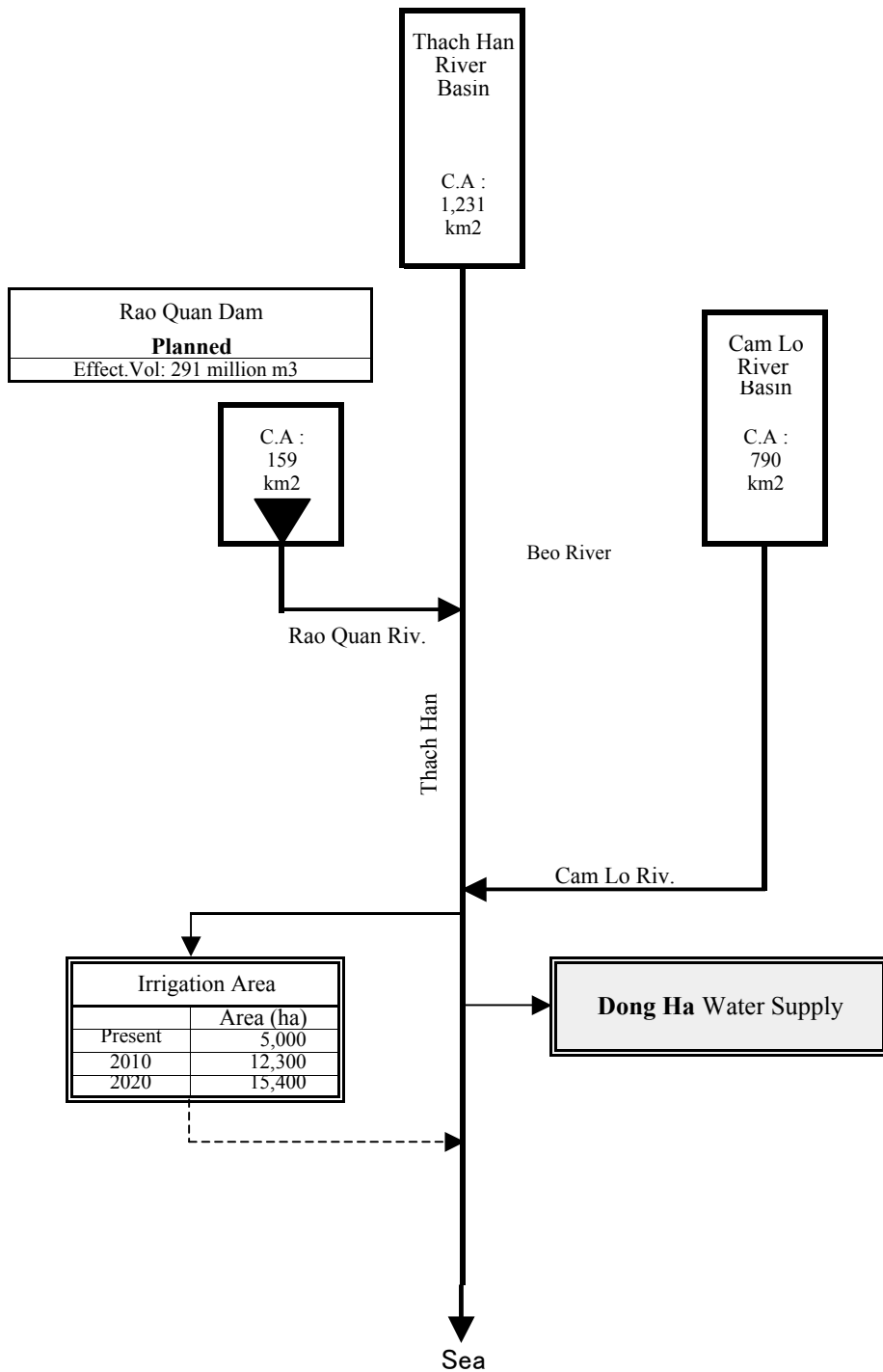

The Study on Nationwide Water Resources
Development and Management in the Socialist
Republic of Vietnam

JAPAN INTERNATIONAL COOPERATION

Hình 7.5

**Mô hình sơ đồ cân bằng nước
(Lưu vực sông Thạch Hãn)**

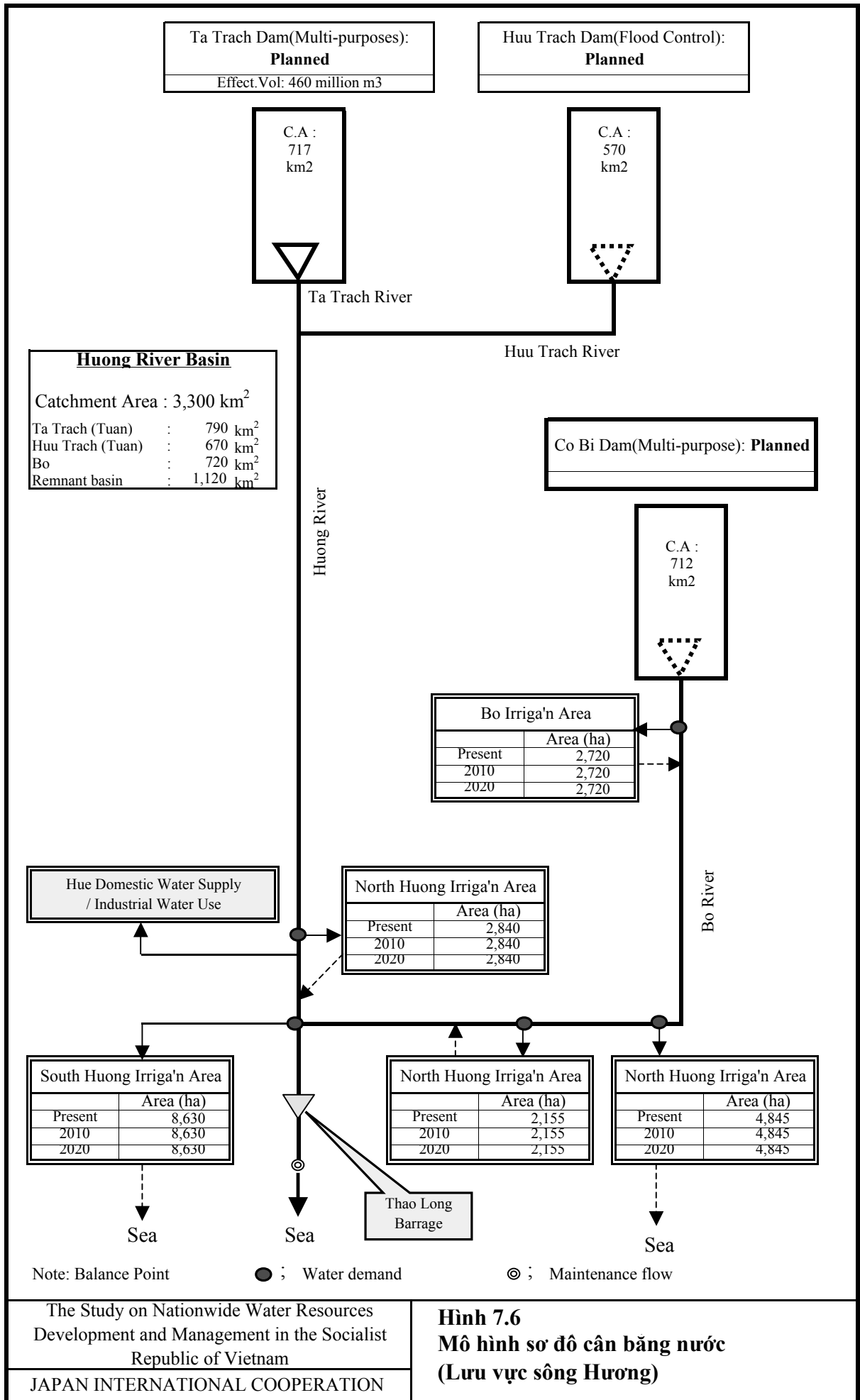

The Study on Nationwide Water Resources
Development and Management in the Socialist
Republic of Vietnam

JAPAN INTERNATIONAL COOPERATION

Hình 7.6
Mô hình sơ đồ cân bằng nước
(Lưu vực sông Hương)

Vu Gia - Thu Bon River Basin

Catchment Area : 11,510 km²

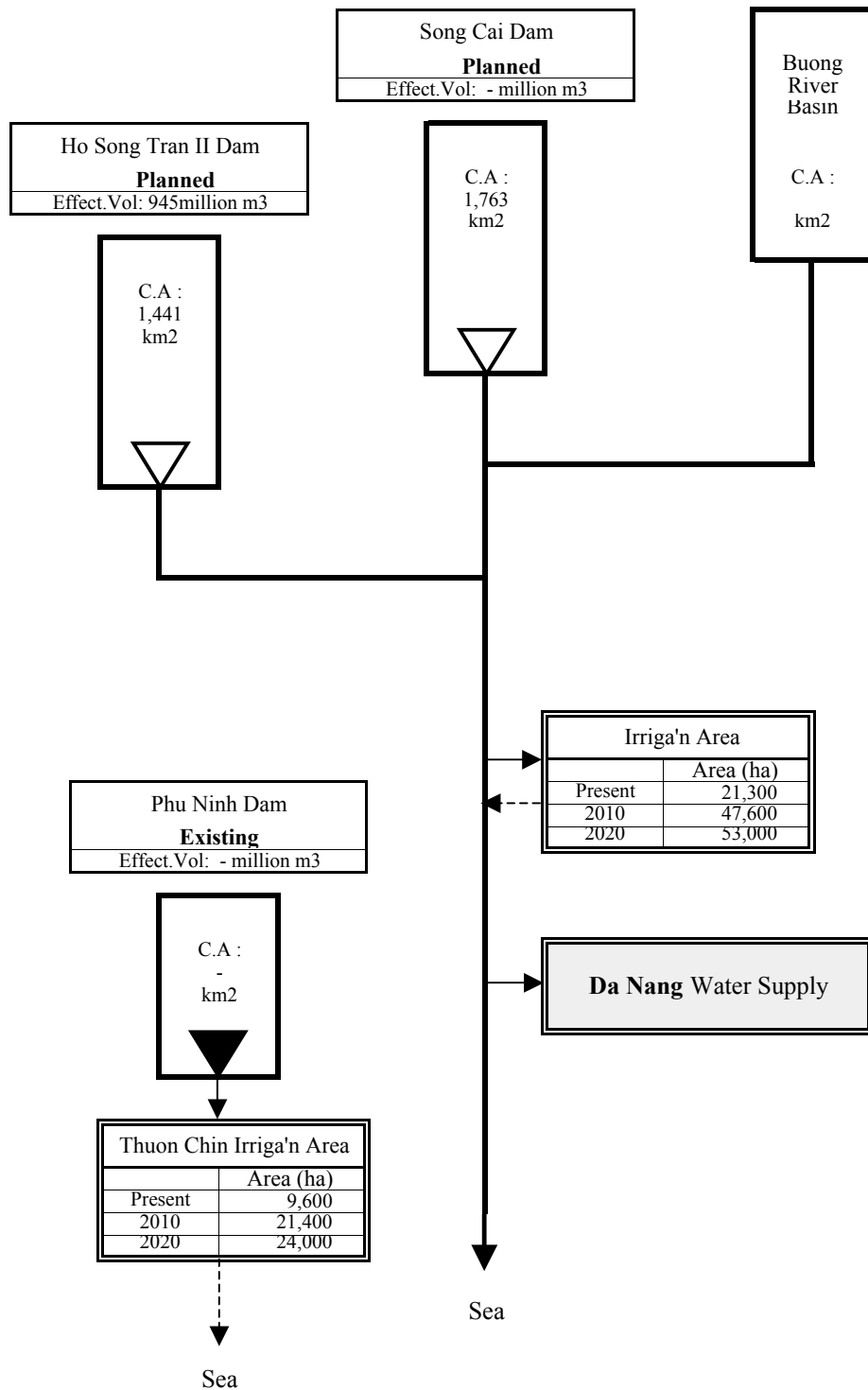

The Study on Nationwide Water Resources Development and Management in the Socialist Republic of Vietnam

JAPAN INTERNATIONAL COOPERATION

Hình 7.7

**Mô hình sơ đồ cân bằng nước
(Lưu vực sông Vũ Gia - Thu Bồn)**

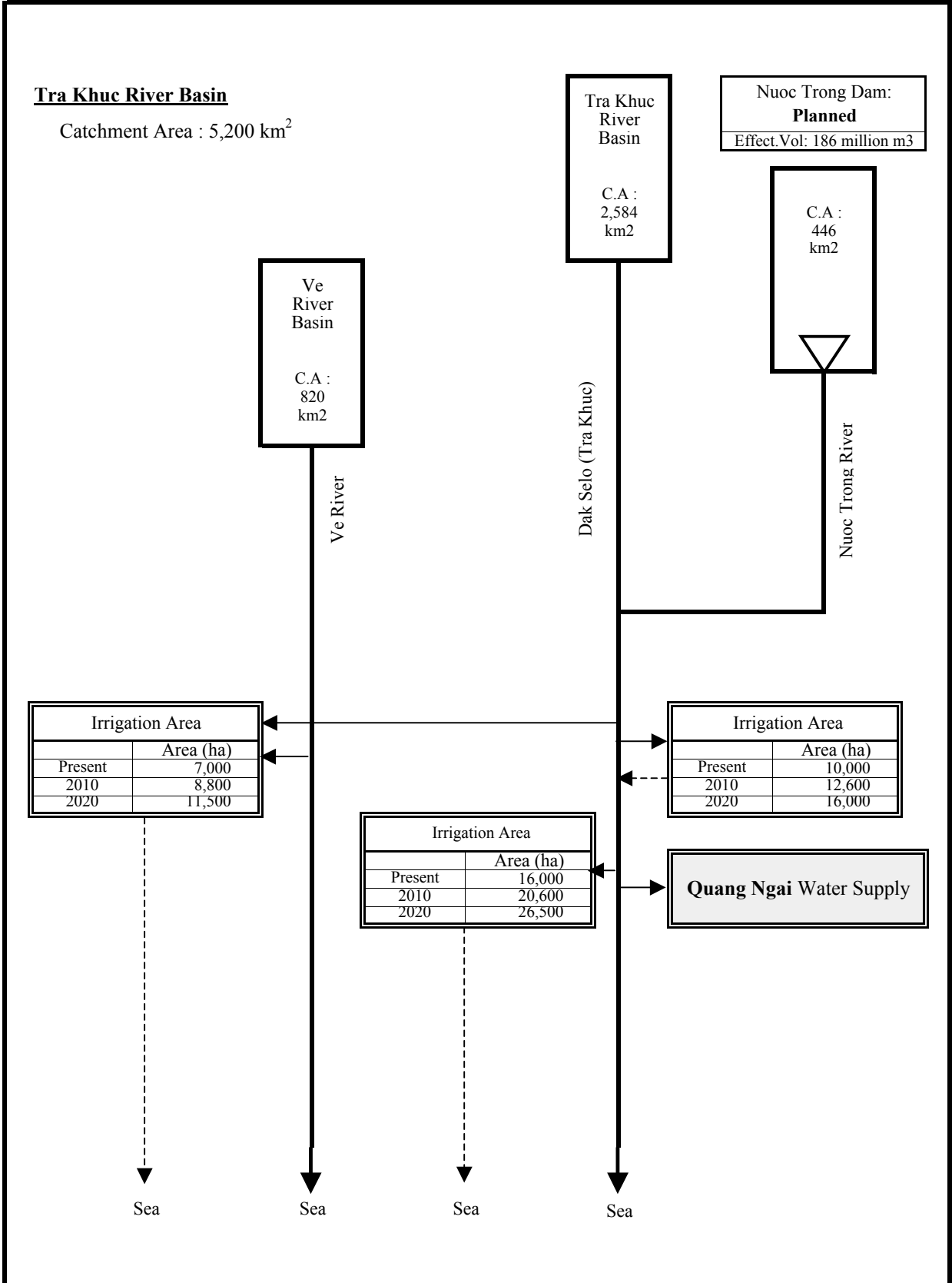

Hình 7.8
Mô hình sơ đồ cân bằng nước
(Lưu vực sông Trà Khúc)

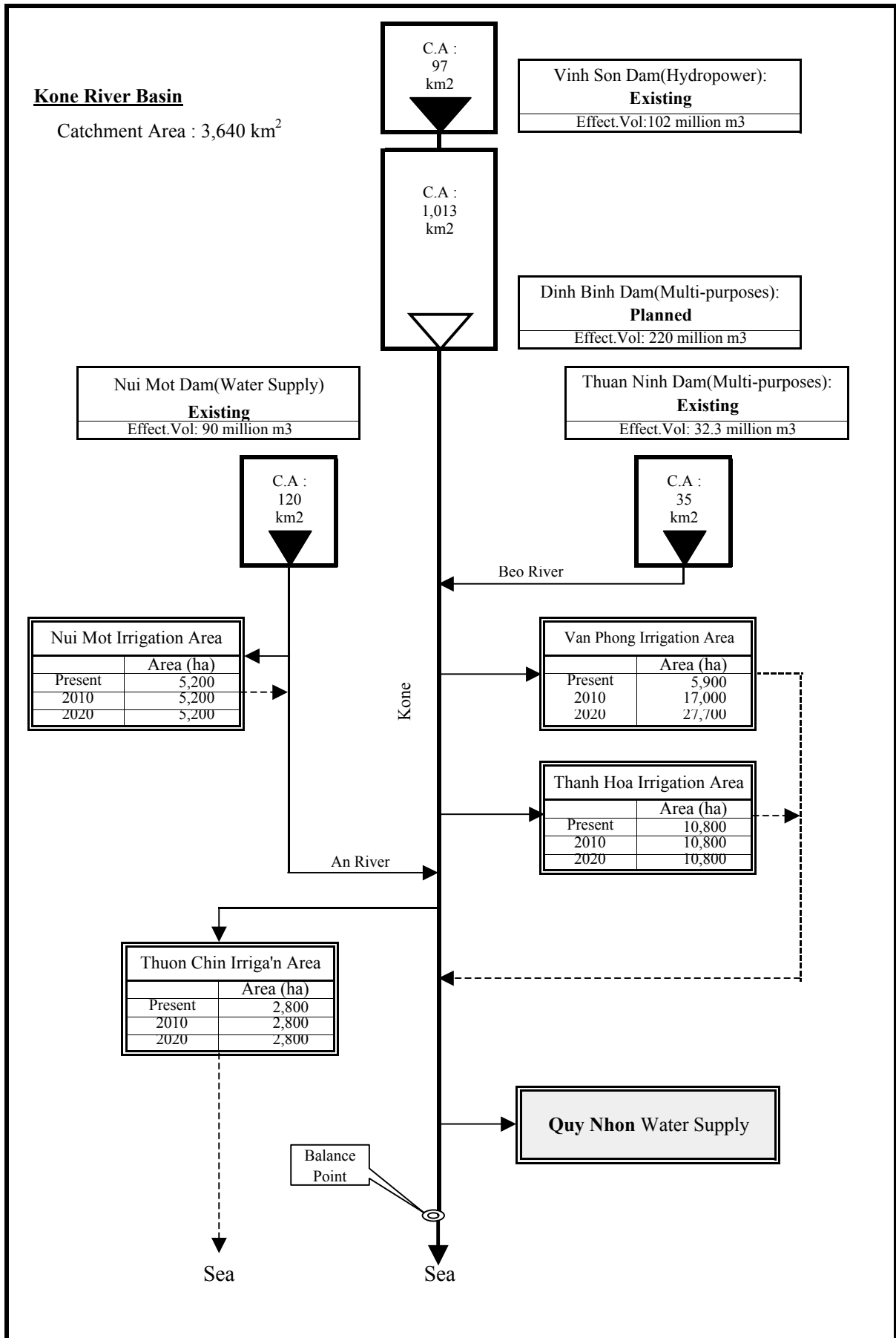

The Study on Nationwide Water Resources
Development and Management in the Socialist
Republic of Vietnam

JAPAN INTERNATIONAL COOPERATION

Hình 7.9
Mô hình sơ đồ cân bằng nước
(Lưu vực sông Kone)

Ba River Basin

Catchment Area : 14,030 km²

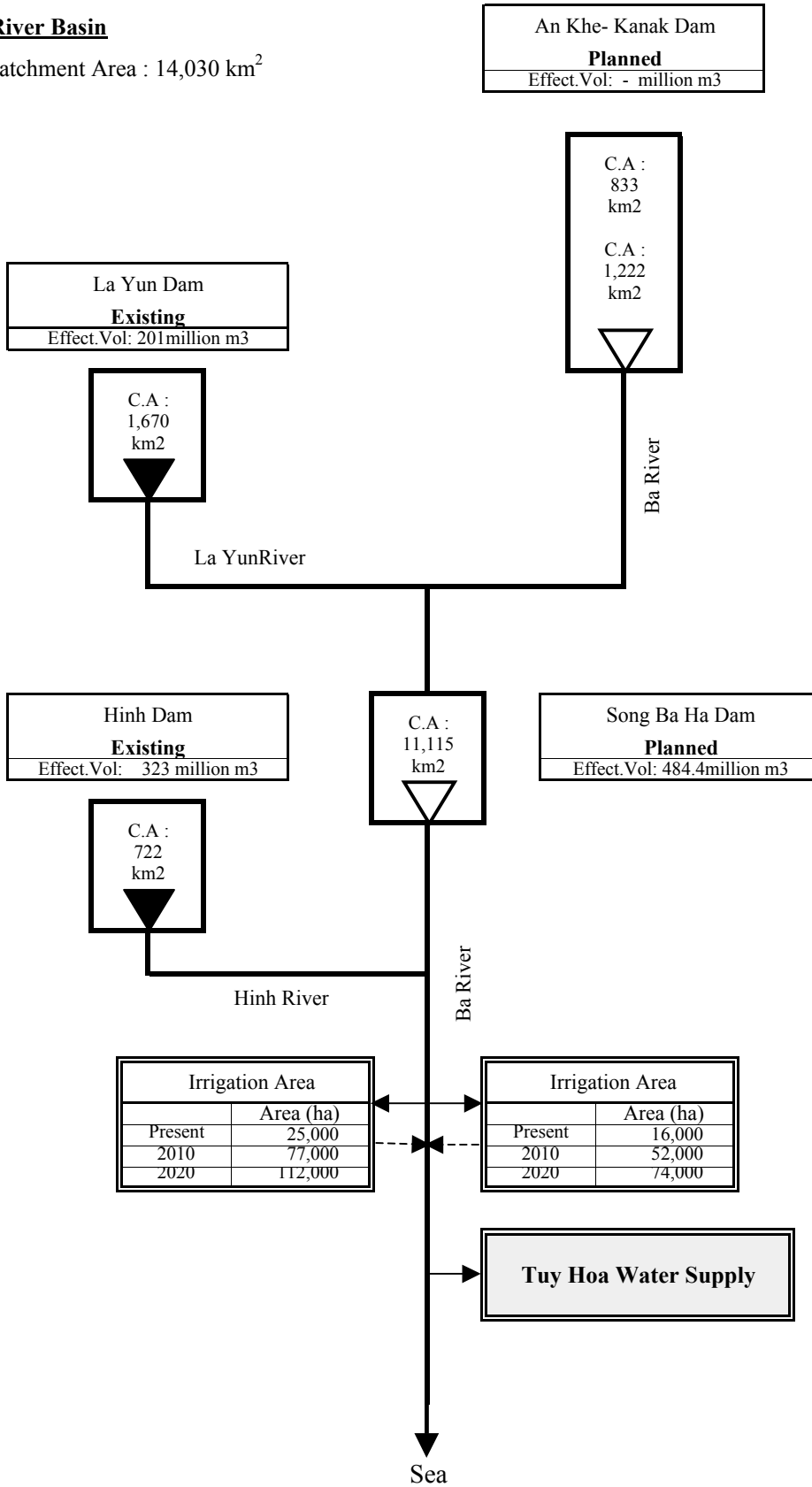

Hình 7.10
Mô hình sơ đồ cân bằng nước
(Lưu vực sông Ba)

Sesan River Basin

Catchment Area : 11,530 km²

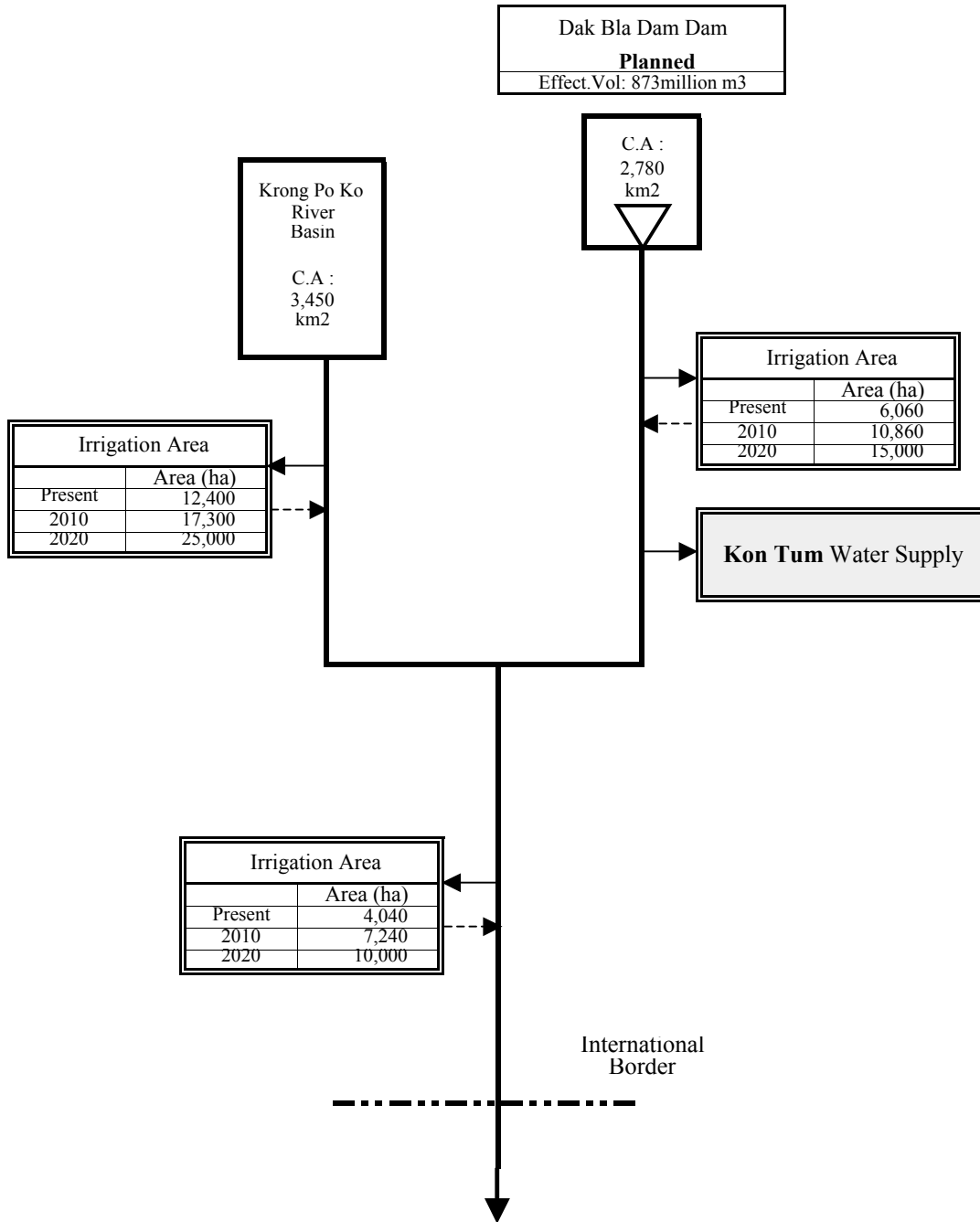

The Study on Nationwide Water Resources
Development and Management in the Socialist
Republic of Vietnam

JAPAN INTERNATIONAL COOPERATION

Hình 7.11

**Mô hình sơ đồ cân bằng nước
(Lưu vực sông Sesan)**

Srepok River Basin

Catchment Area : 12,030 km²

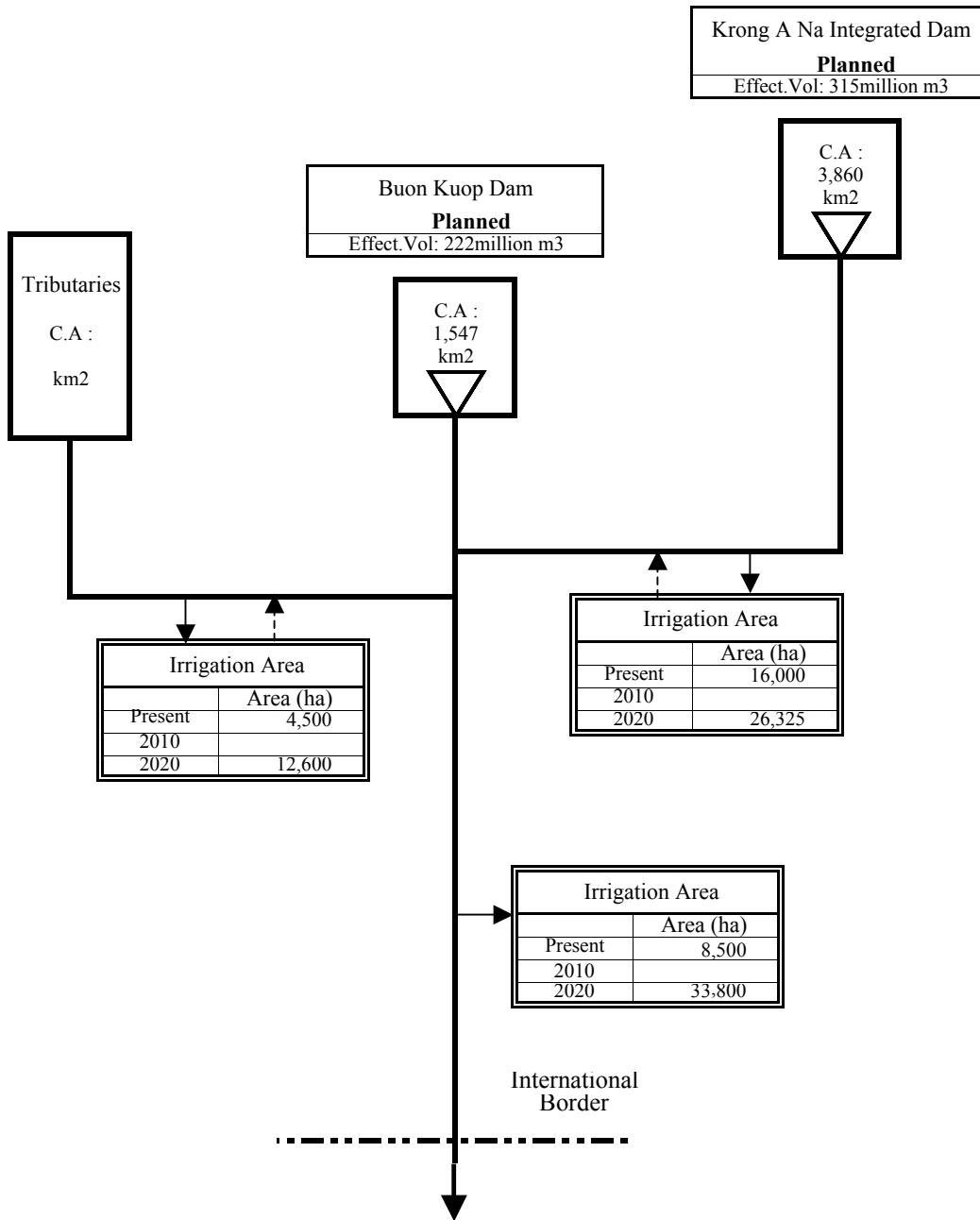

The Study on Nationwide Water Resources Development and Management in the Socialist Republic of Vietnam

JAPAN INTERNATIONAL COOPERATION

Hình 7.12

Mô hình sơ đồ cân bằng nước (Lưu vực sông Srepok)

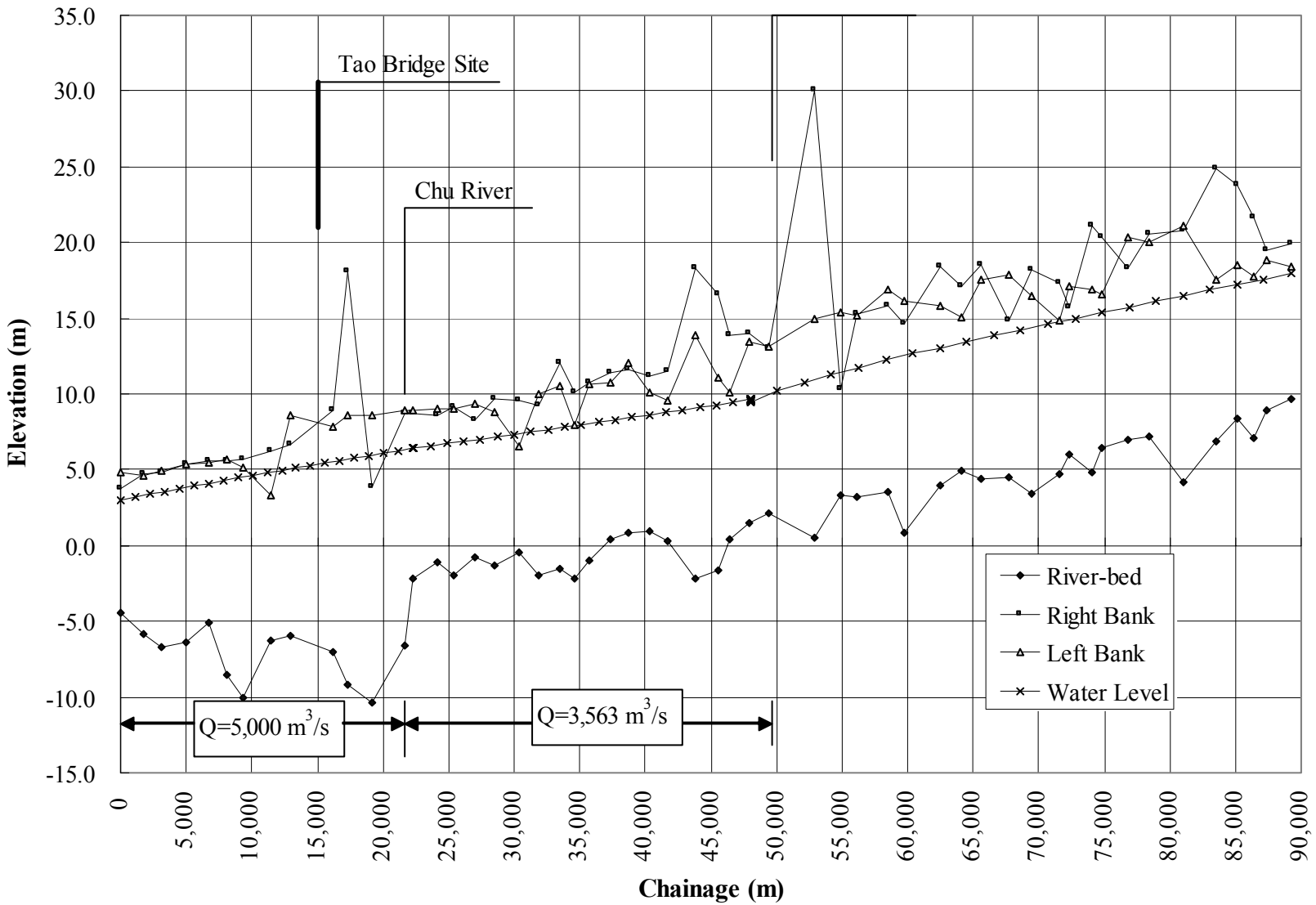

Hình 9.1
 Mặt cắt dọc sông Mã trong khu vực hay bị lũ lụt

Hình 9.2
Mặt cắt dọc sông Cả trong khu vực
hay bị lũ lụt

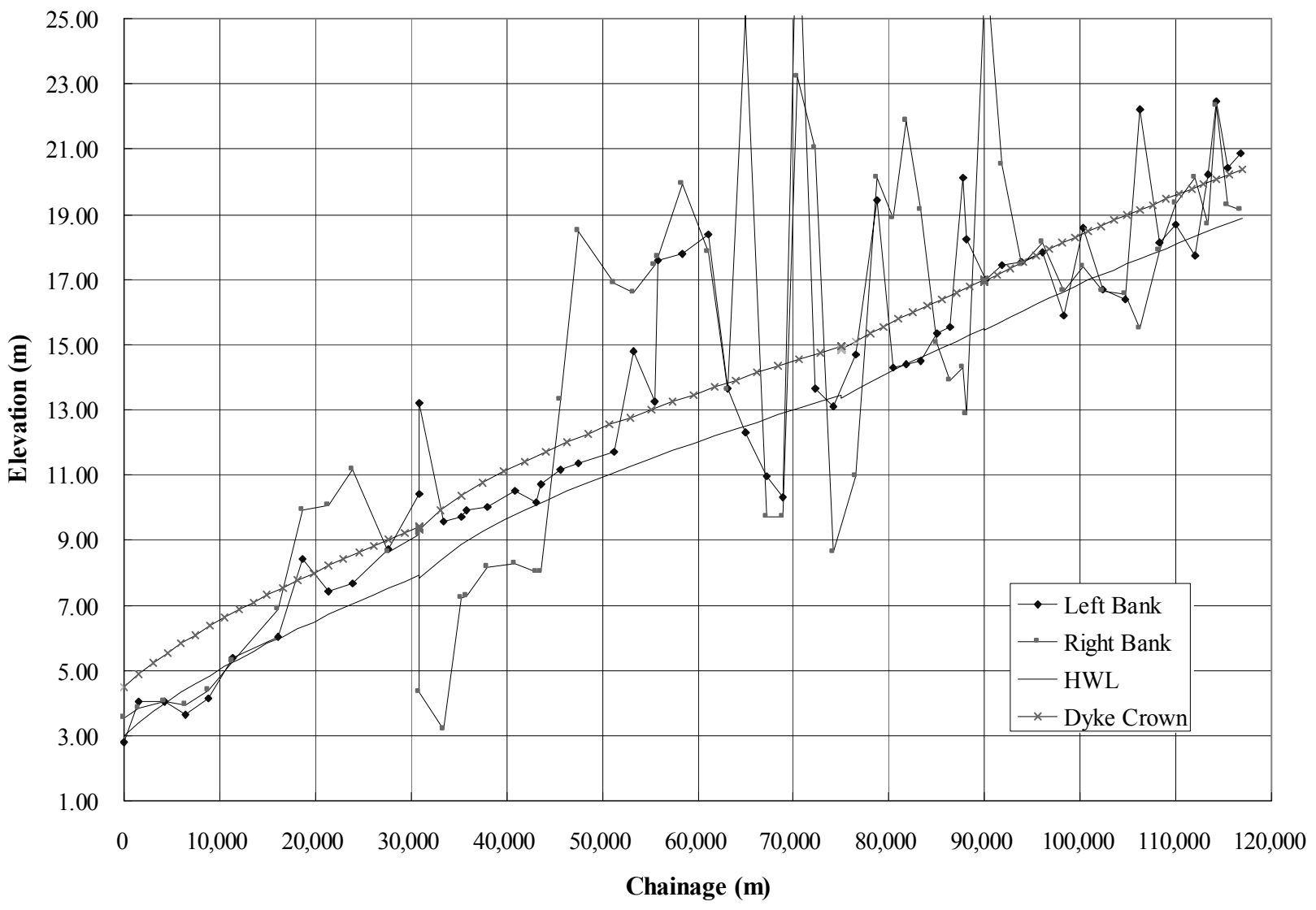

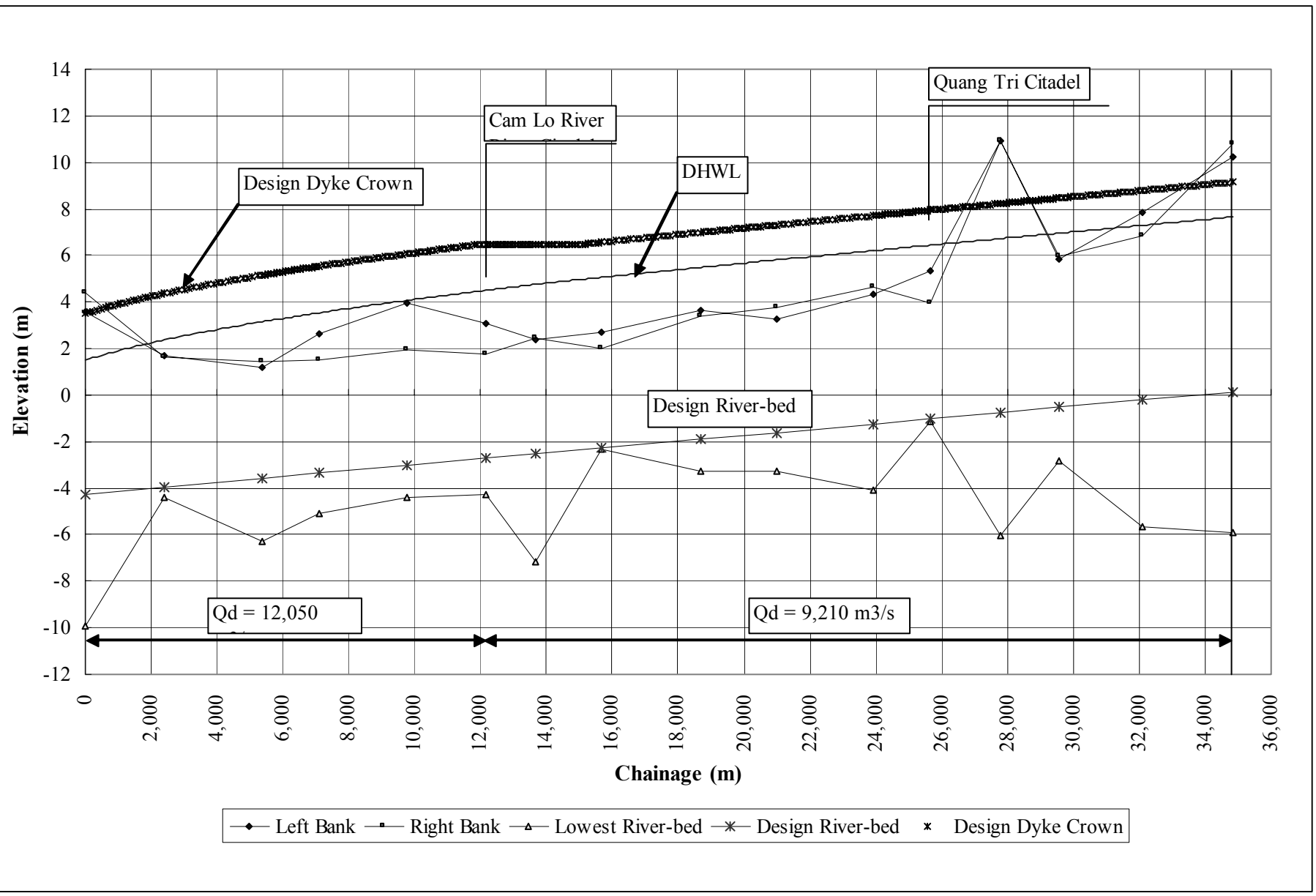

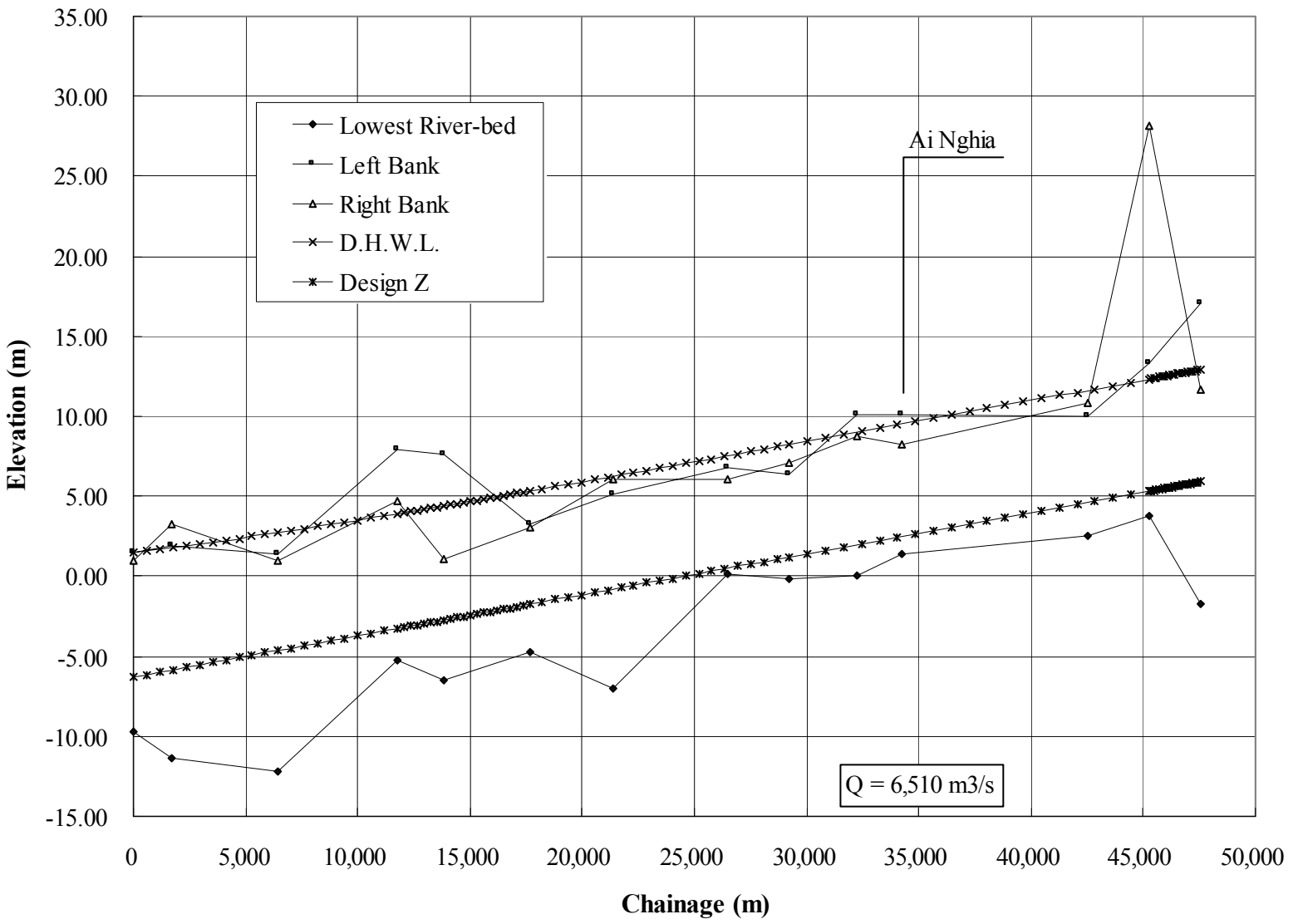

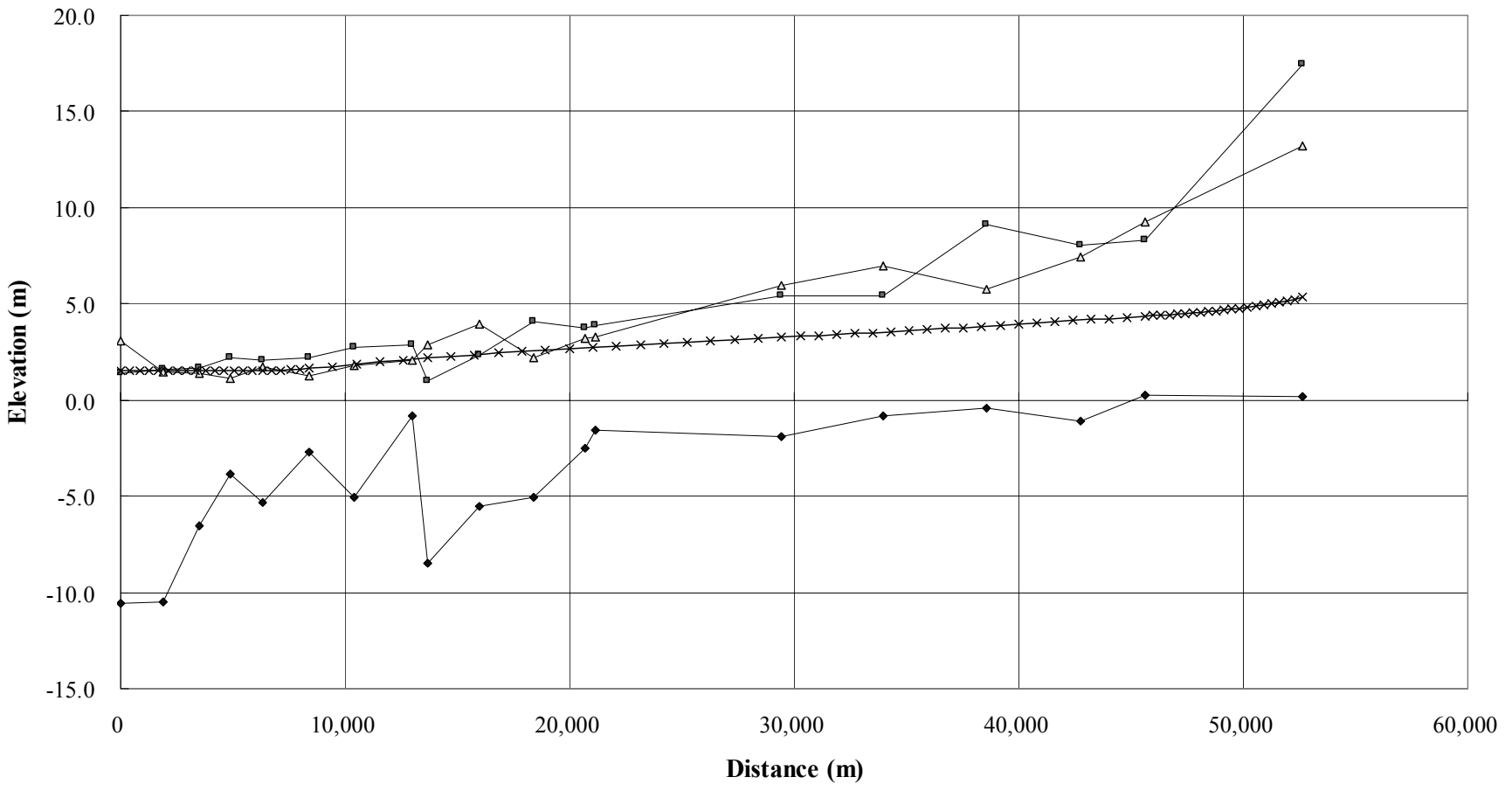

◆ Lowest River-bed ■ Left Bank ▲ Right Bank × Q = 600 m³/s

The Study on Nationwide Water Resources Development and Management in the Socialist Republic of Vietnam
 JAPAN INTERNATIONAL COOPERATION AGENCY
Hình 9.5
Mặt cắt dọc sông Thu Bồn trong khu vực hay bị lũ lụt

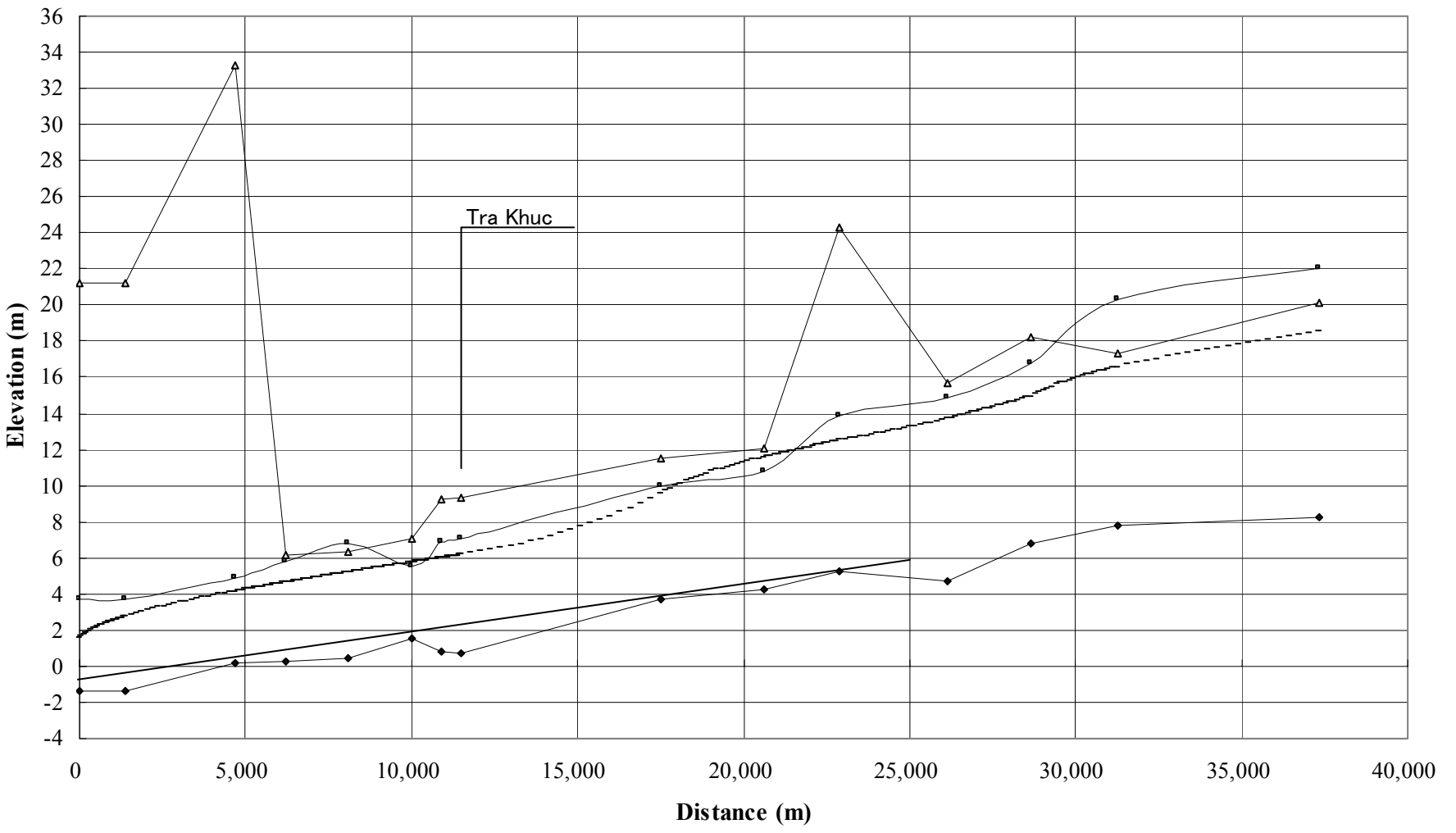

◆ Lowest River-bed ■ Left Bank ▲ Right Bank - Q = 6,040 m³/s

