

KF-6

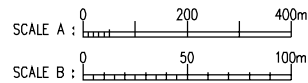
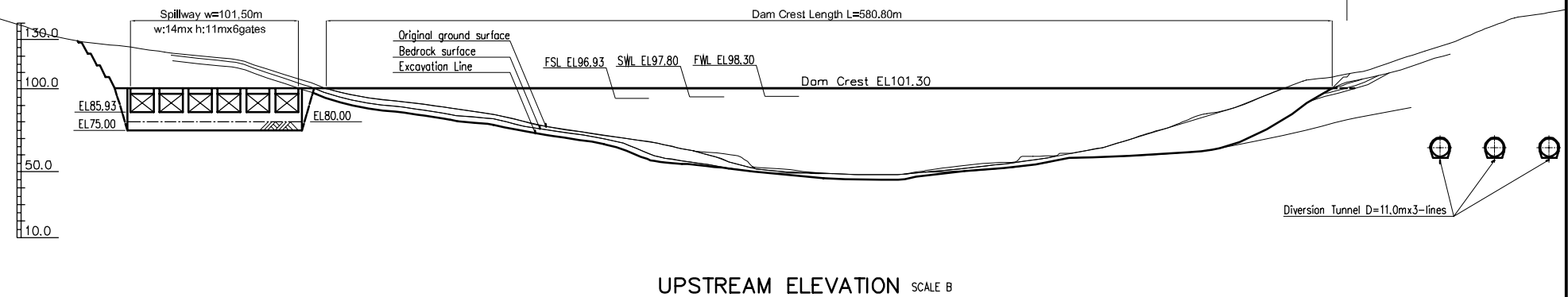
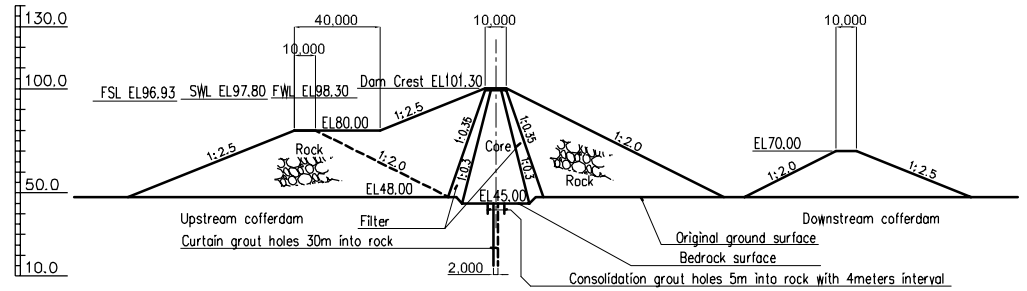
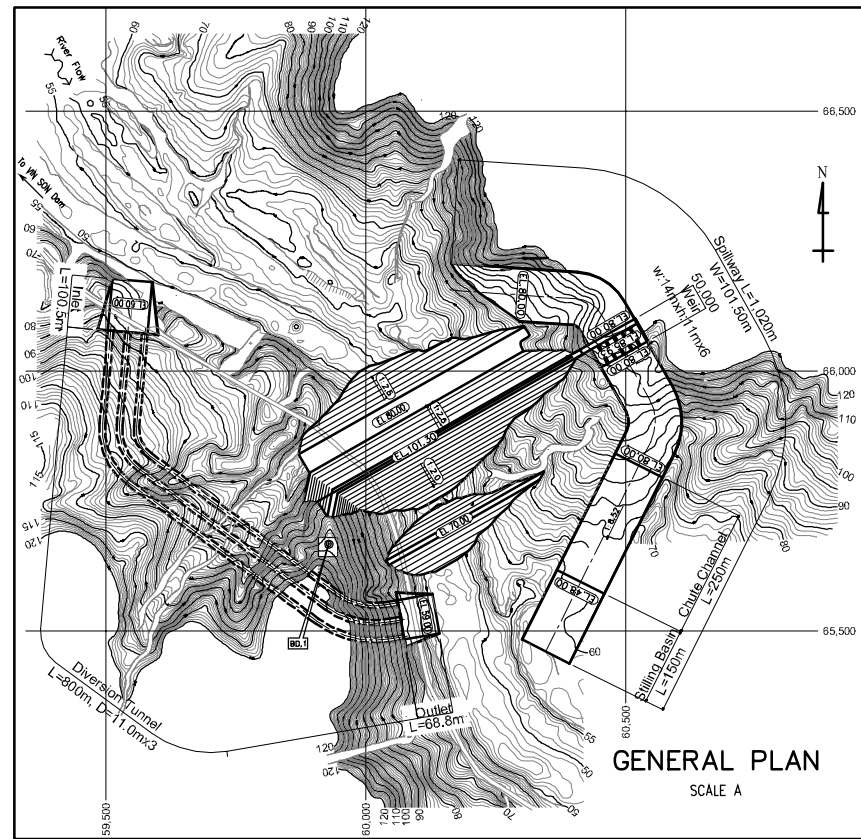
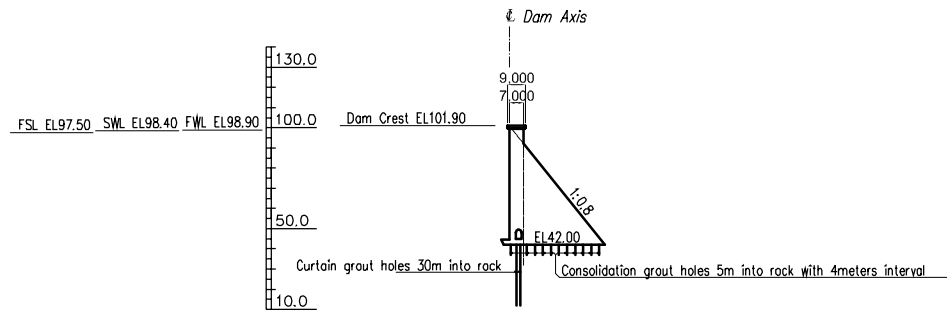
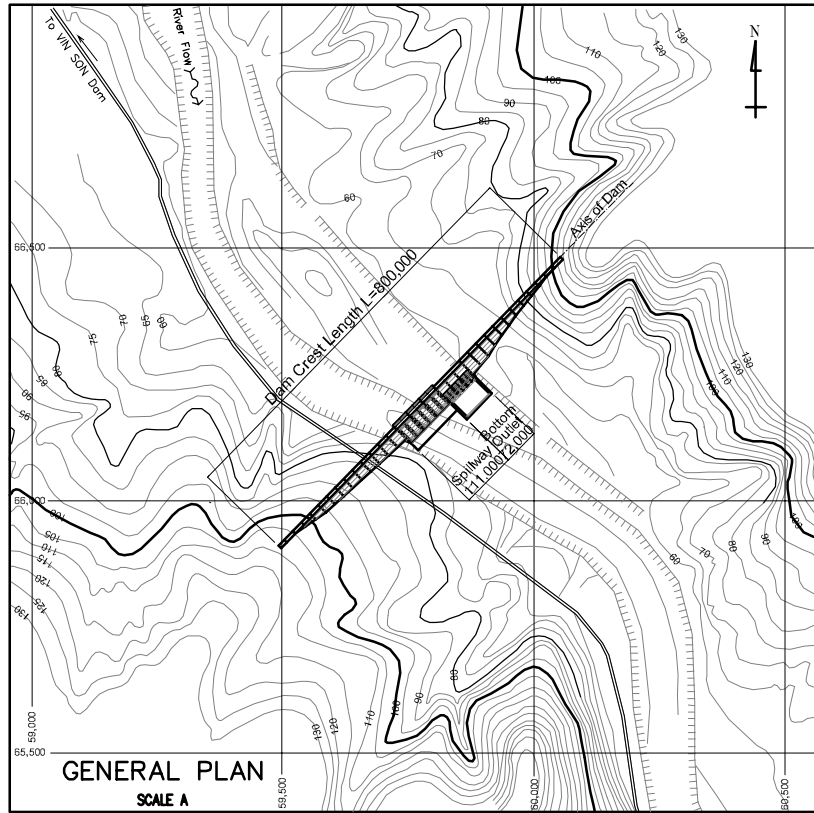
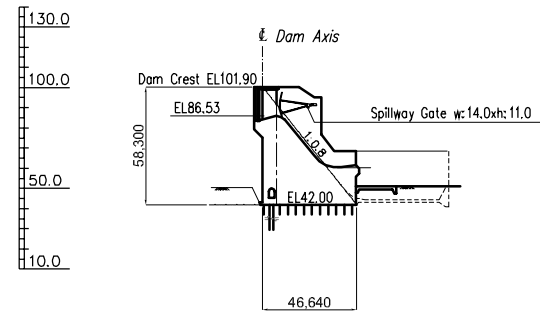

Figure K.6
Site I Rockfill Dam
General Plan



NON-OVERFLOW SECTION
SCALE B



OVERFLOW SECTION
SCALE B

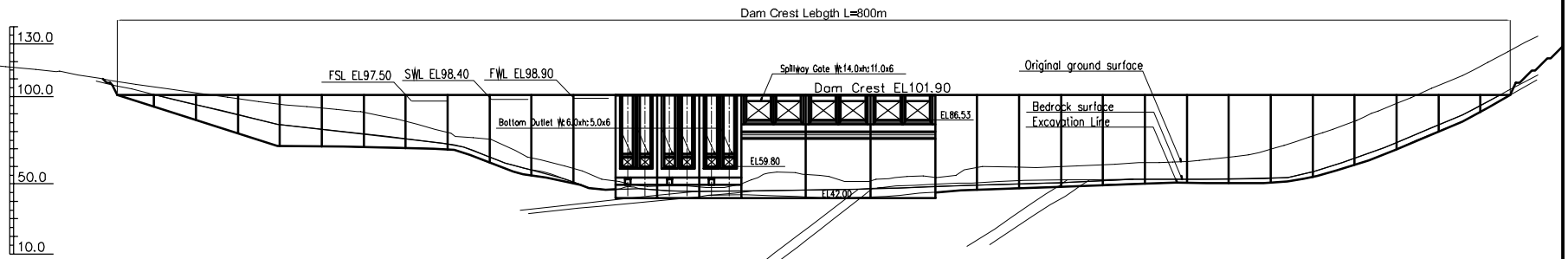

UPSTREAM ELEVATION SCALE B

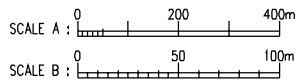

The Study on Nationwide Water Resources
Development and Management
in the Socialist Republic of Vietnam
JAPAN INTERNATIONAL COOPERATION AGENCY

Figure K.7
Site II Concrete Gravity Dam
General Plan

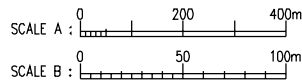
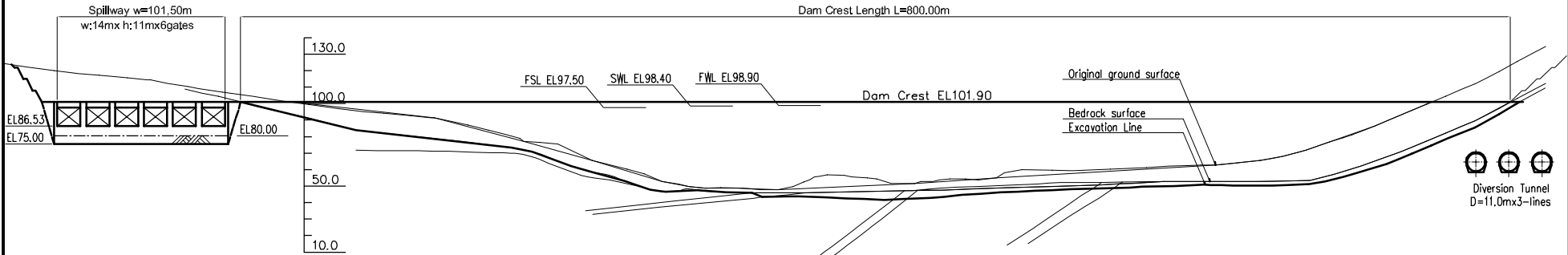
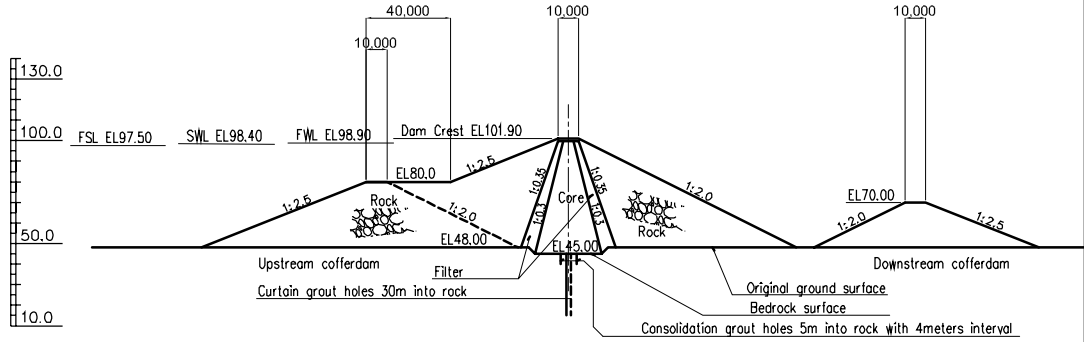
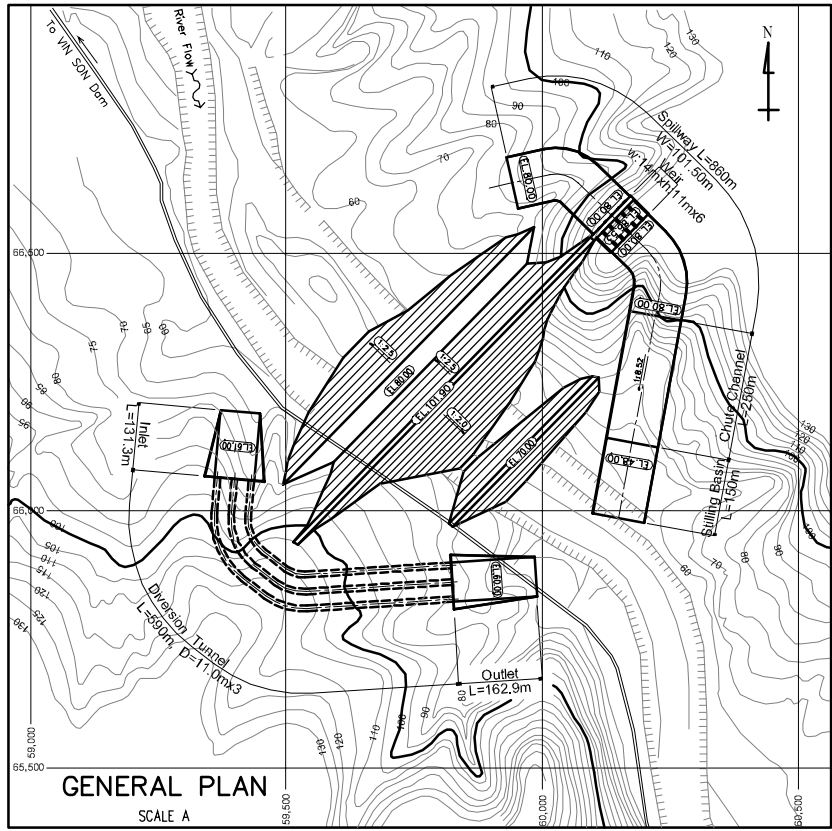

The Study on Nationwide Water Resources
Development and Management
in the Socialist Republic of Vietnam
JAPAN INTERNATIONAL COOPERATION AGENCY

Figure K.8

Site II Rockfill Dam
General Plan

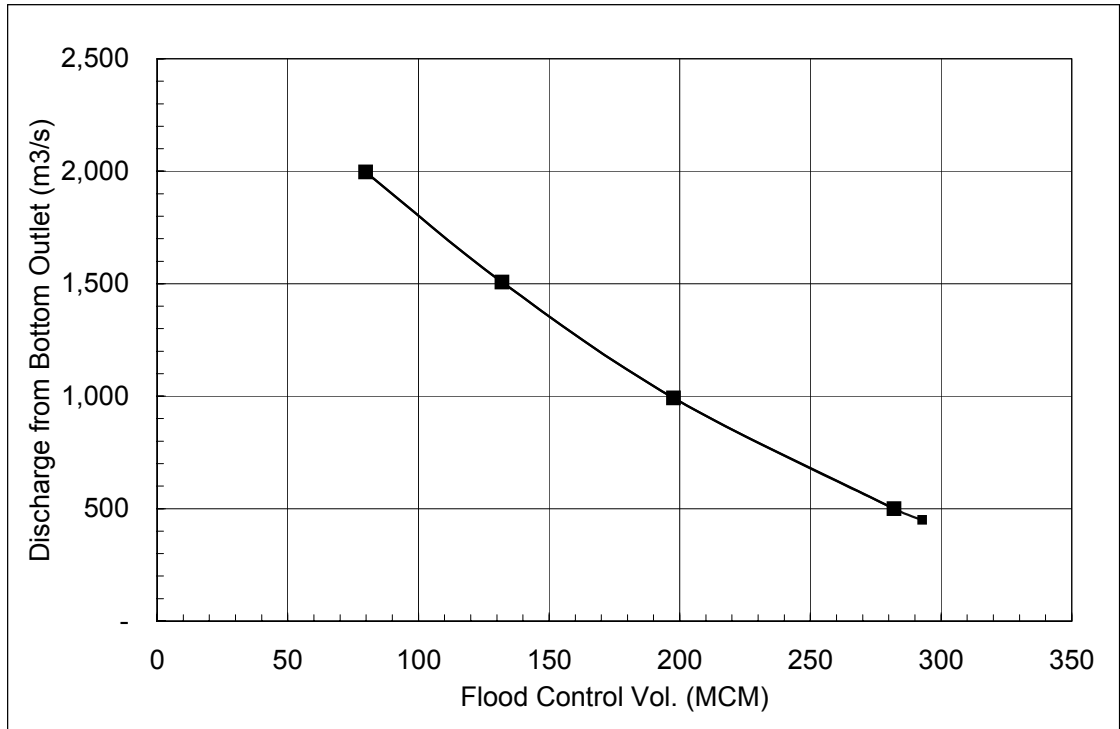

Figure K.9
Relation between Flood Control Volume
and Discharge from Bottom Outlet

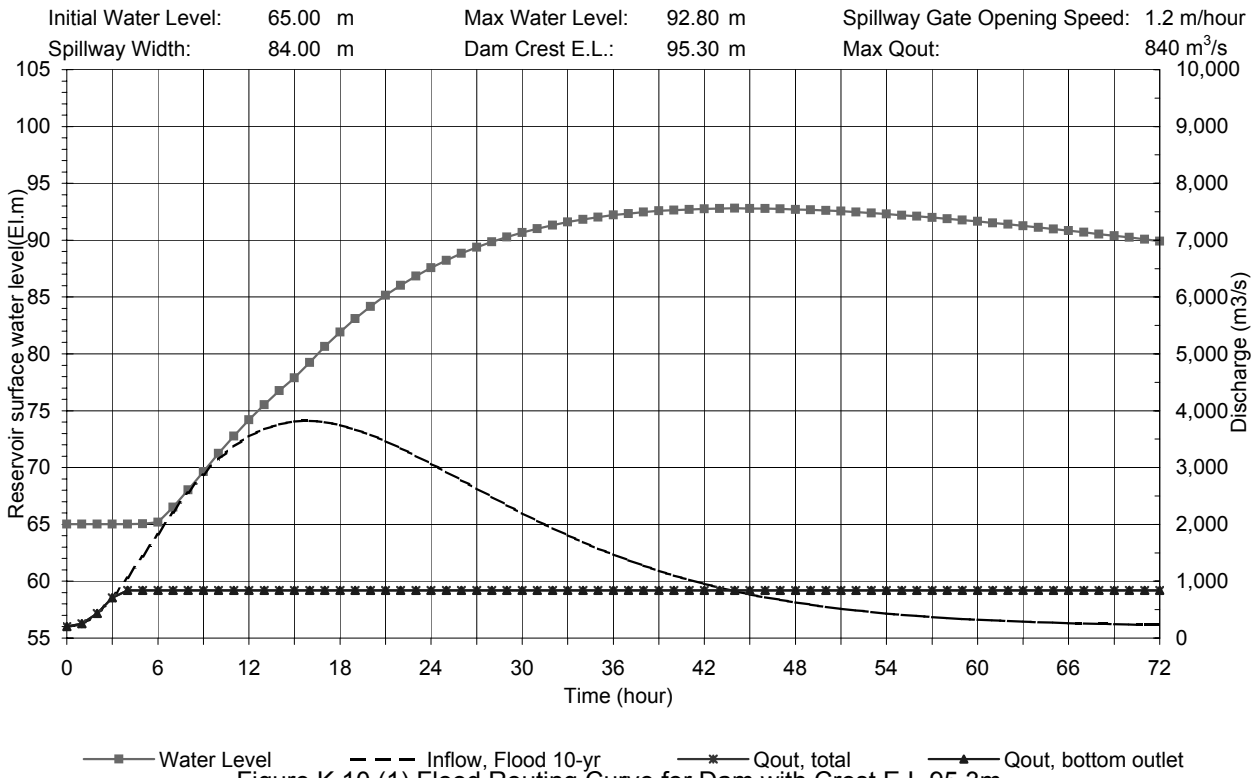

Figure K.10 (1) Flood Routing Curve for Dam with Crest E.L.95.3m
 (10-yr Probable Flood, $Q_p=3,821\text{m}^3/\text{s}$, Initial WL=65.00m)

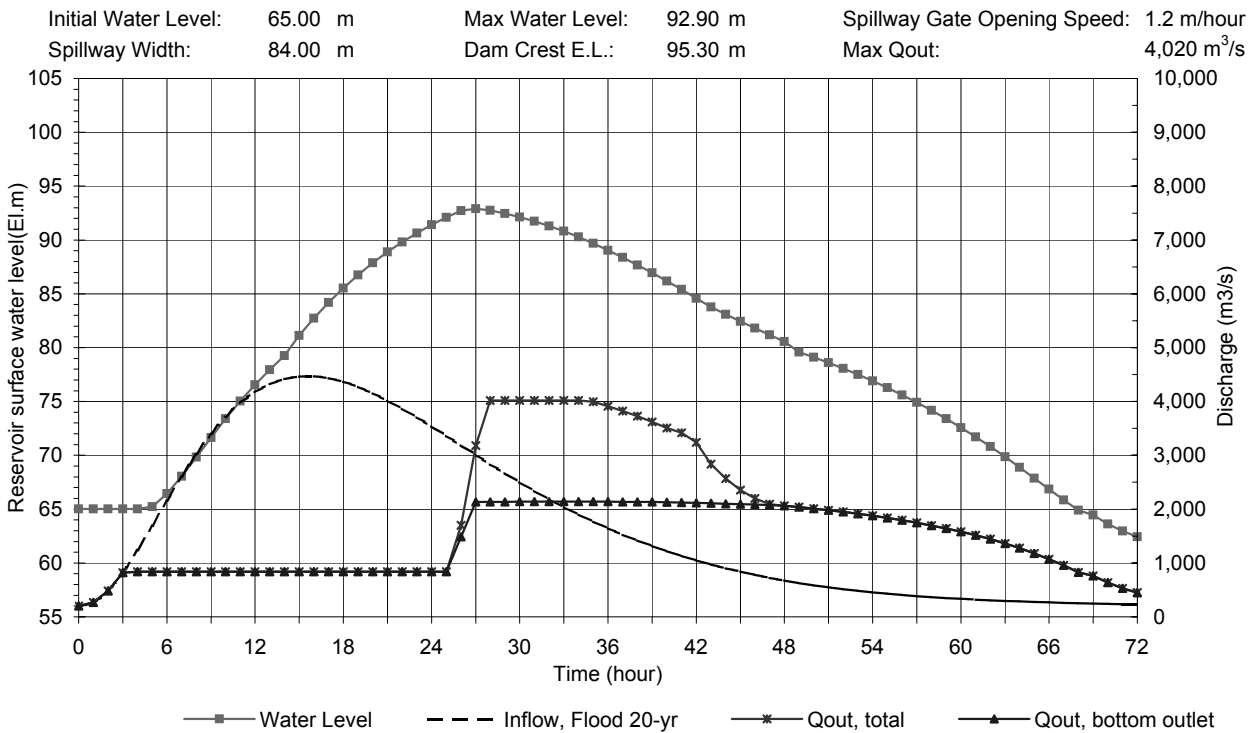

Figure K.10 (2) Flood Routing Curve for Dam with Crest E.L.95.3m
 (20-yr Probable Flood, $Q_p=4,475\text{m}^3/\text{s}$, Initial WL=65.00m)

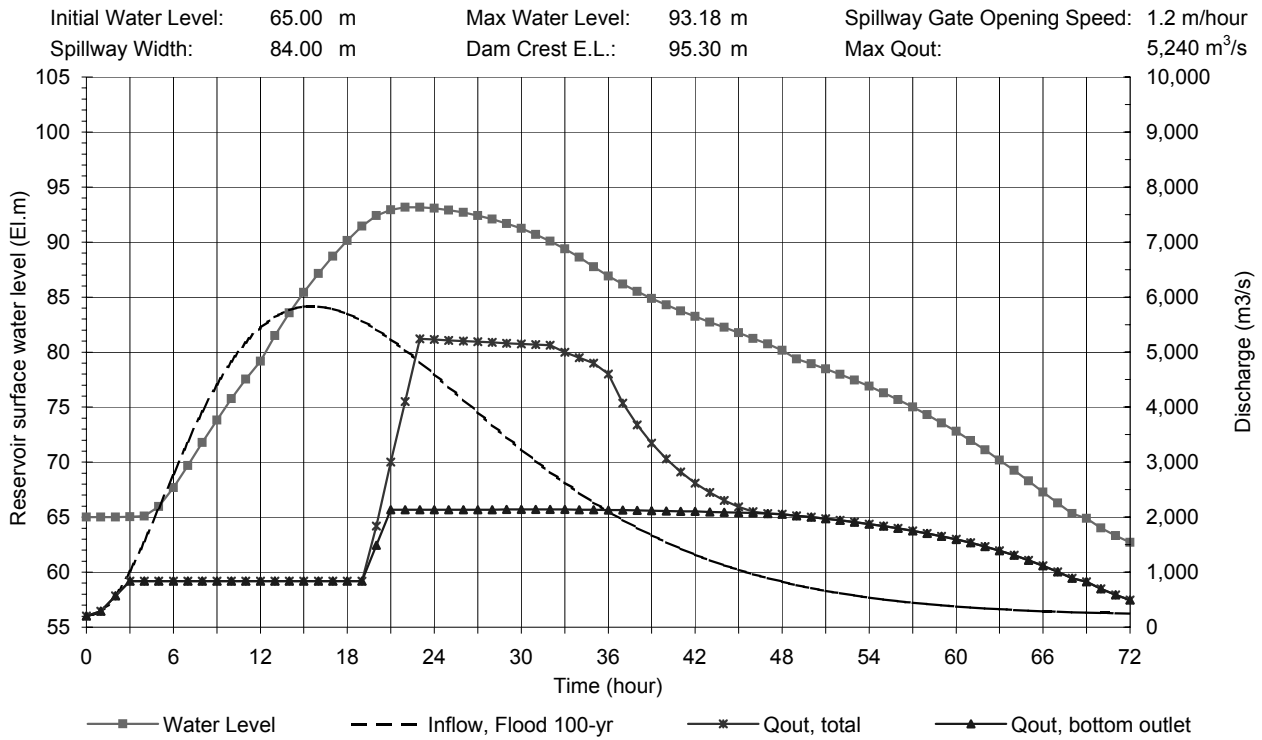

Figure K.10 (3) Flood Routing Curve for Dam with Crest E.L.95.3m
(100-yr Probable Flood, $Q_p=5,832\text{m}^3/\text{s}$, Initial WL=65.00m)

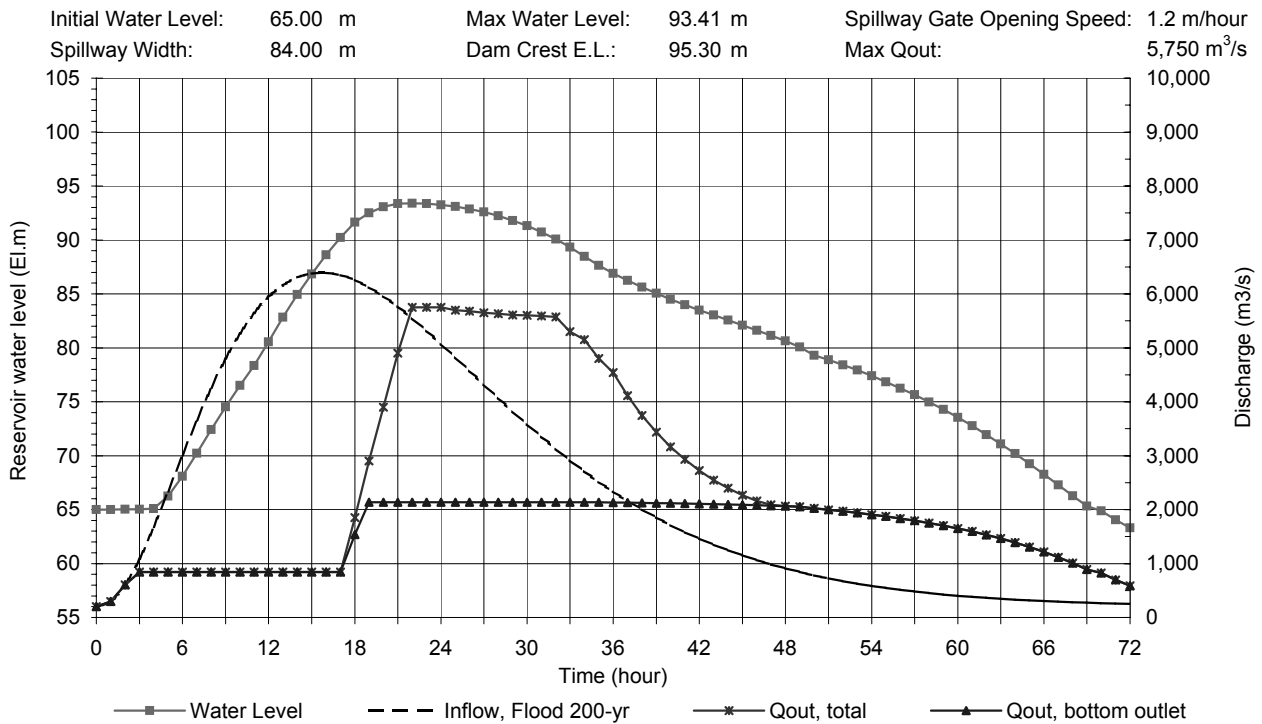

Figure K.10 (4) Flood Routing Curve for Dam with Crest E.L.95.3m
(200-yr Probable Flood, $Q_p=6,397\text{m}^3/\text{s}$, Initial WL=65.00m)

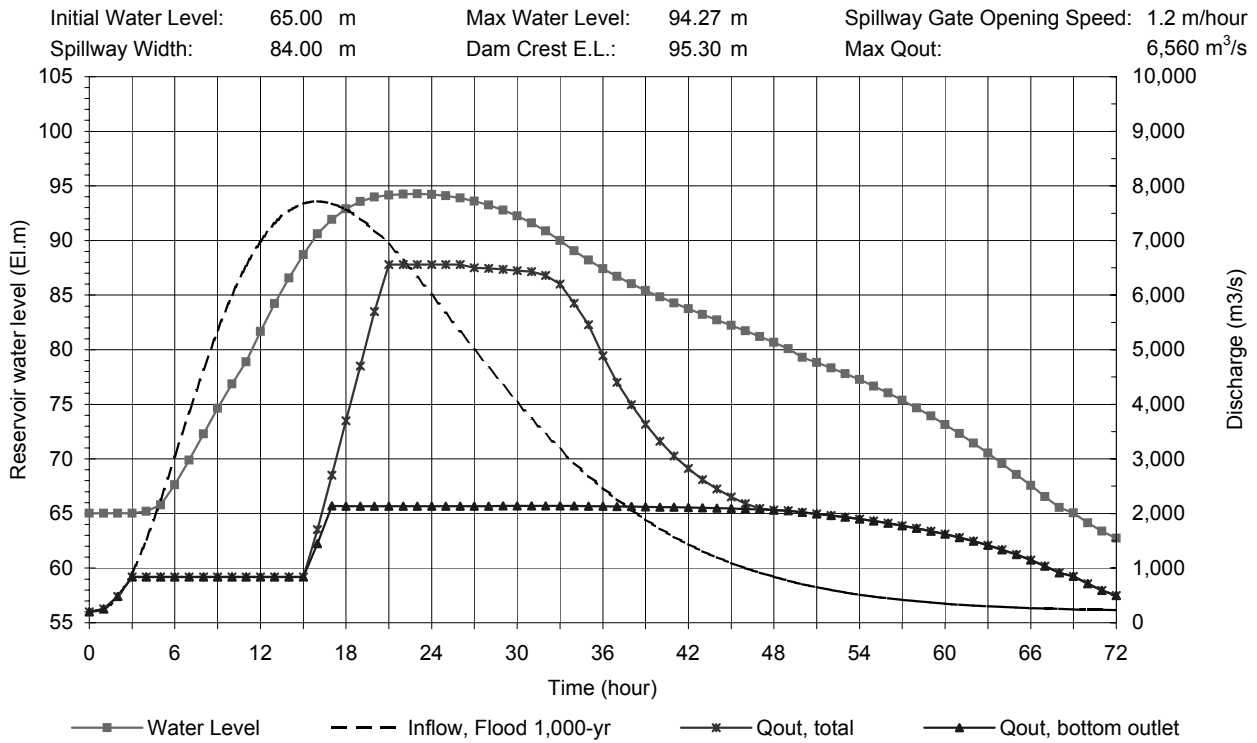

Figure K.10 (5) Flood Routing Curve for Dam with Crest E.L.95.3m
(1,000-yr Probable Flood, $Q_p=7,718\text{m}^3/\text{s}$, Initial WL=65.00m)

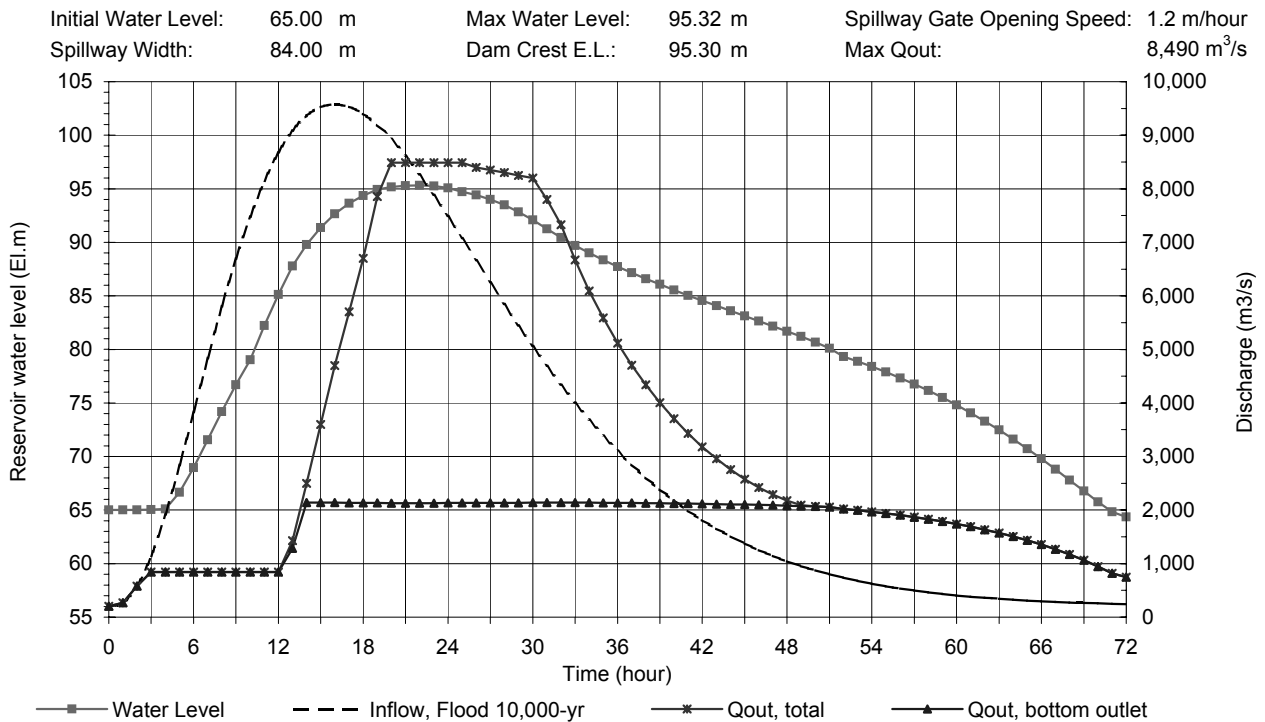

Figure K.10 (6) Flood Routing Curve for Dam with Crest E.L.95.3m
(10,000-yr Probable Flood, $Q_p=9,578\text{m}^3/\text{s}$, Initial WL=65.00m)

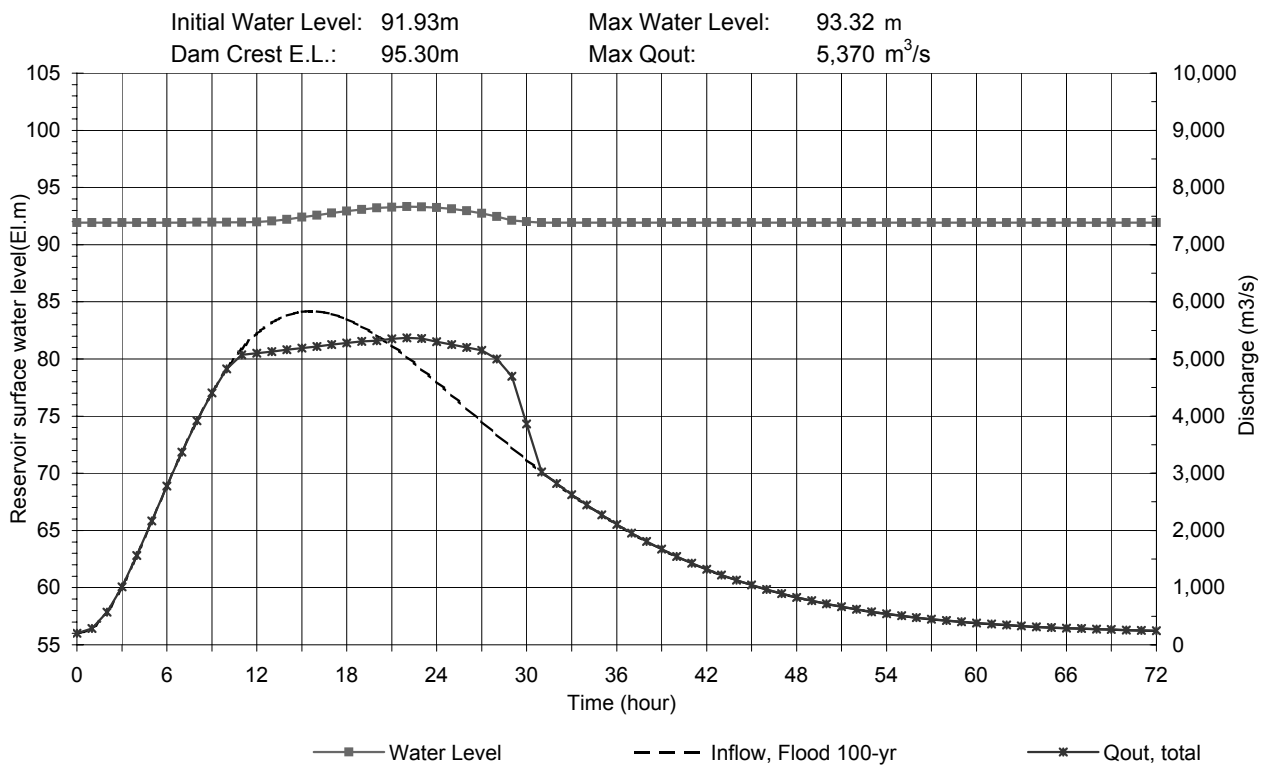

Figure K.10(7) Flood Routing Curve for Dam with Crest E.L.95.3m
 (100-yr Probable Flood, $Q_p=5,832\text{m}^3/\text{s}$, Initial WL=91.93m)

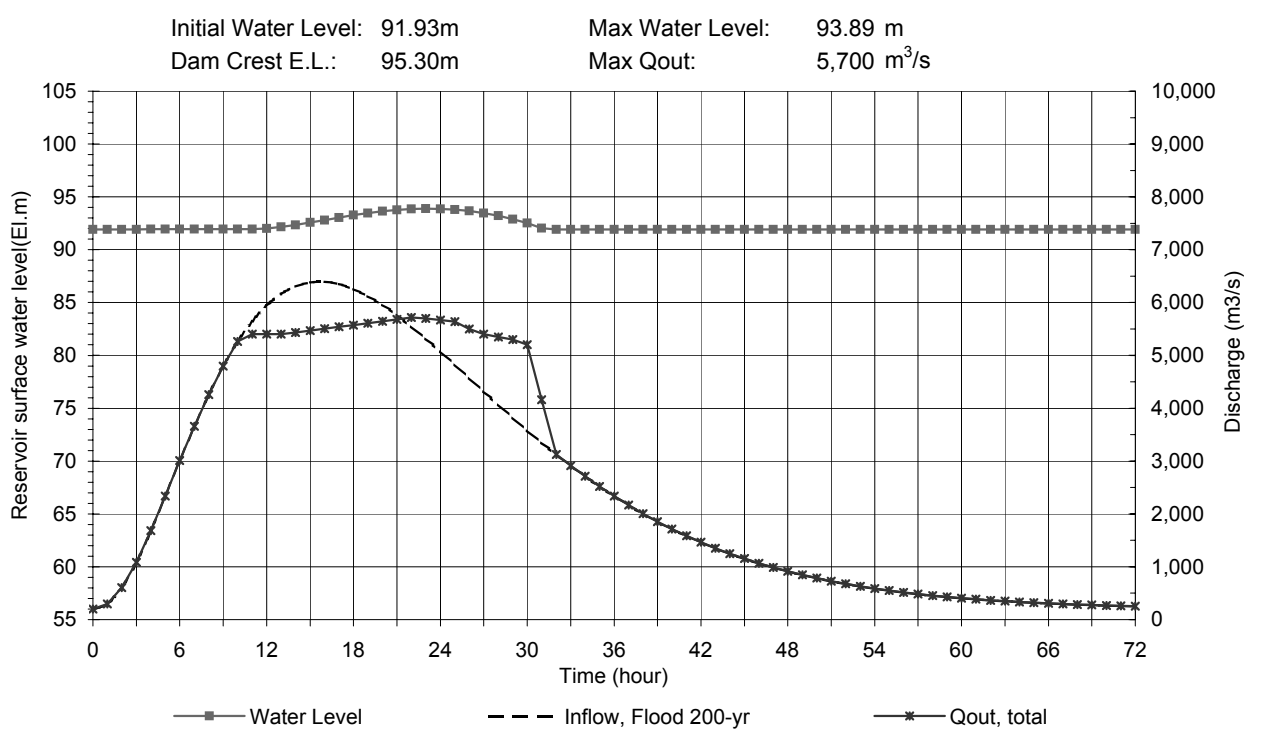

Figure K.10 (8) Flood Routing Curve for Dam with Crest E.L.95.3m
 (200-yr Probable Flood, $Q_p=6,394\text{m}^3/\text{s}$, Initial WL=91.93m)

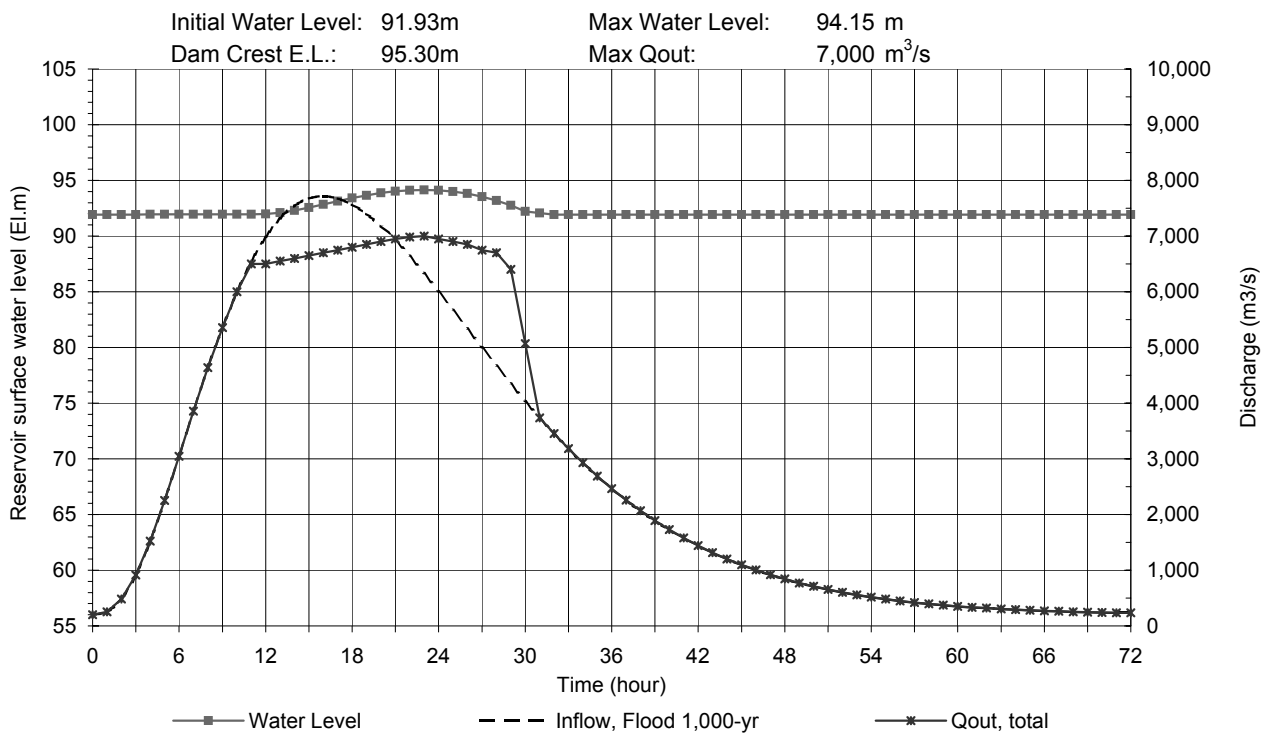

Figure K.10 (9) Flood Routing Curve for Dam with Crest E.L.95.3m
 (1,000-yr Probable Flood, $Q_p=7,718\text{m}^3/\text{s}$, Initial WL=91.93m)

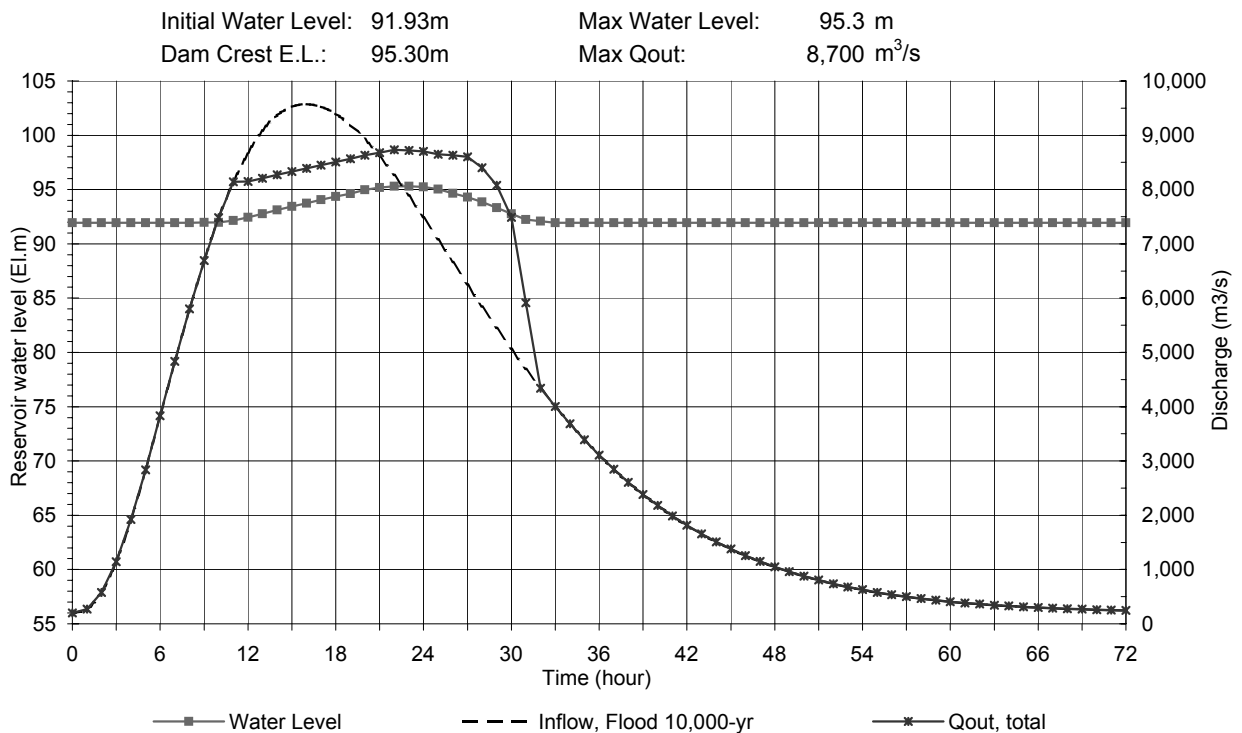

Figure K.10 (10) Flood Routing Curve for Dam with Crest E.L.95.3m
 (10,000-yr Probable Flood, $Q_p=9,578\text{m}^3/\text{s}$, Initial WL=91.93m)

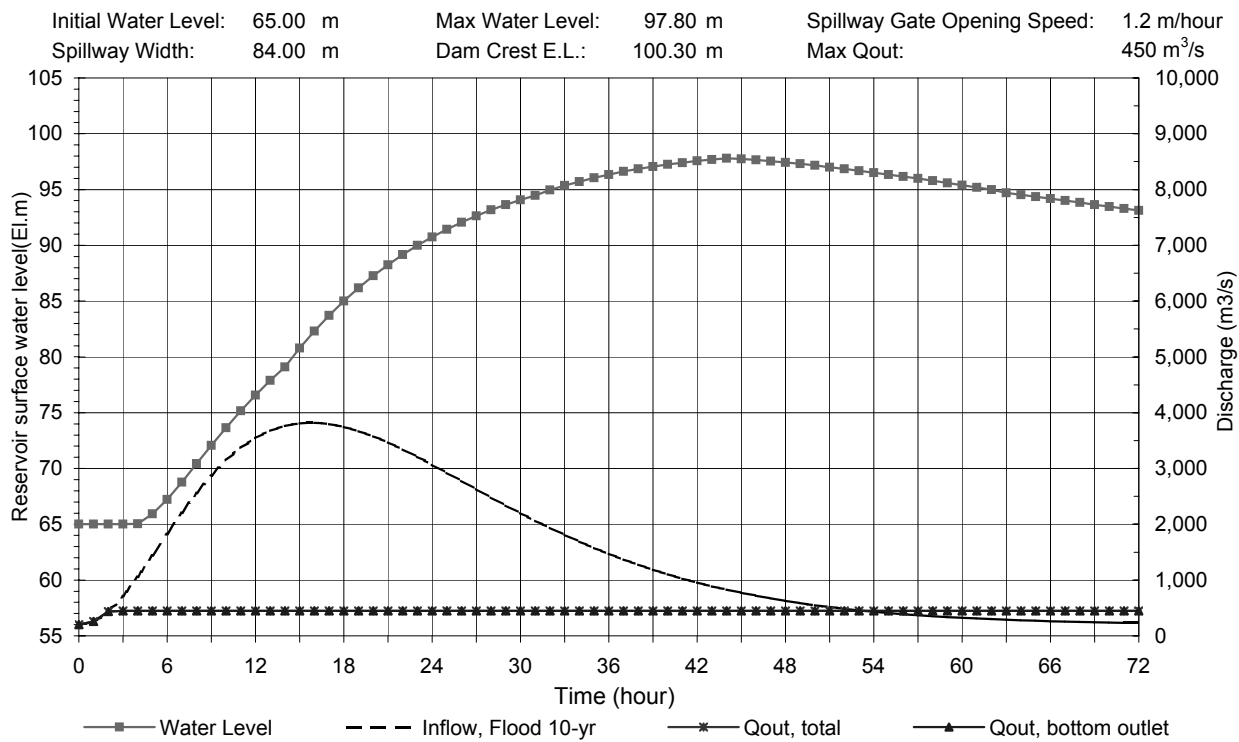

Figure K.11 (1) Flood Routing Curve for Dam with Crest E.L.100.3m
(10-yr Probable Flood, $Q_p=3,821\text{m}^3/\text{s}$, Initial WL=65.00m)

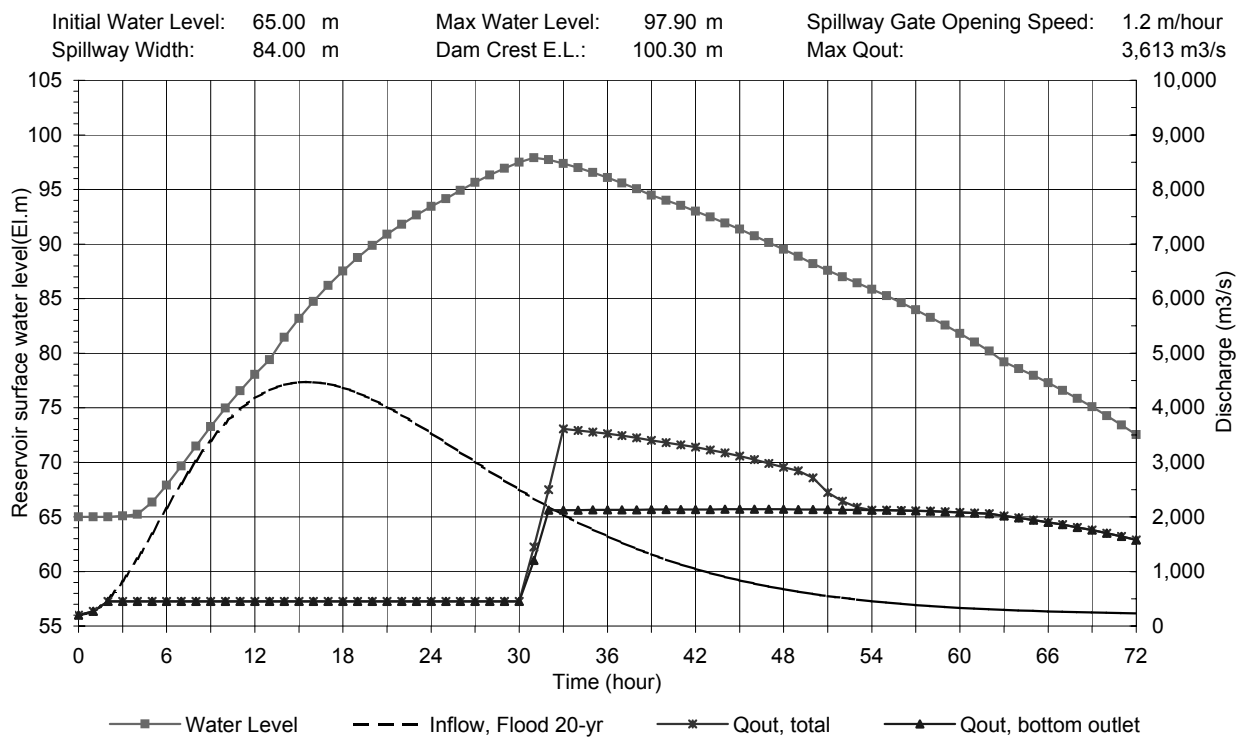

Figure K.11 (2) Flood Routing Curve for Dam with Crest E.L.100.3m
(20-yr Probable Flood, $Q_p=4,475\text{m}^3/\text{s}$, Initial WL=65.00m)

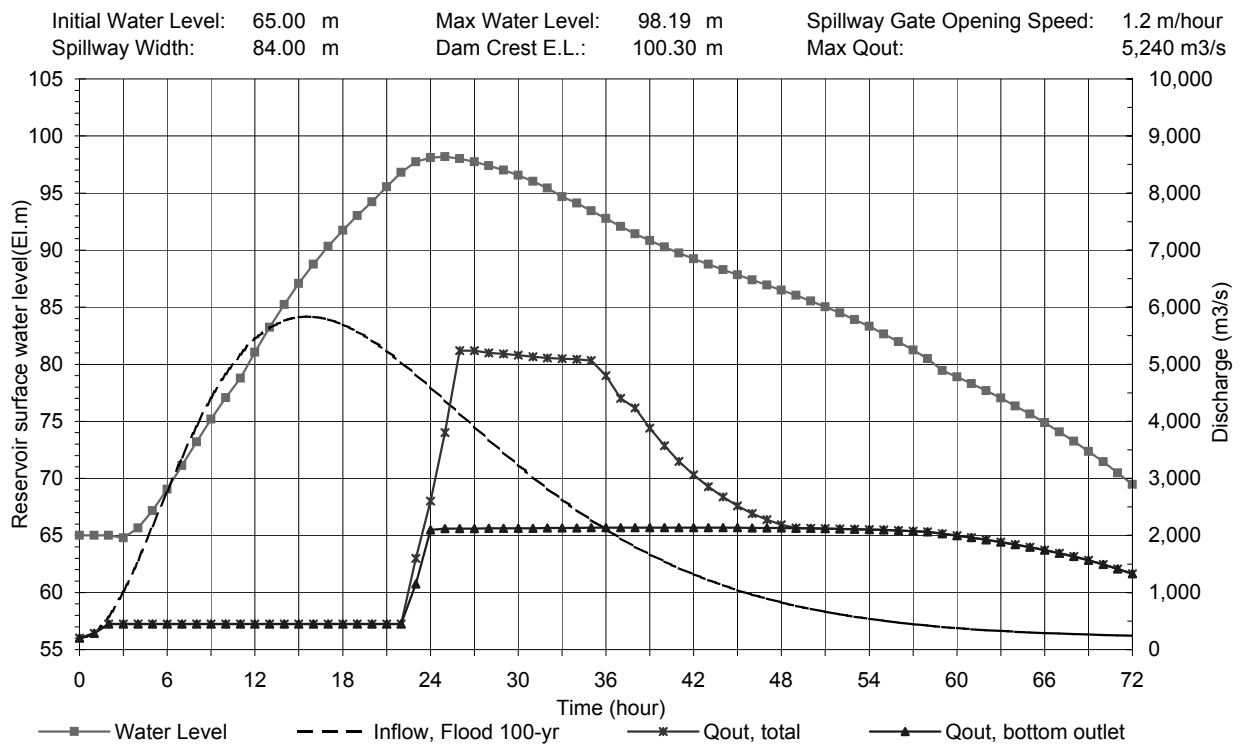

Figure K.11 (3) Flood Routing Curve for Dam with Crest E.L.100.3m
(100-yr Probable Flood, $Q_p=5,832\text{m}^3/\text{s}$, Initial WL=65.00m)

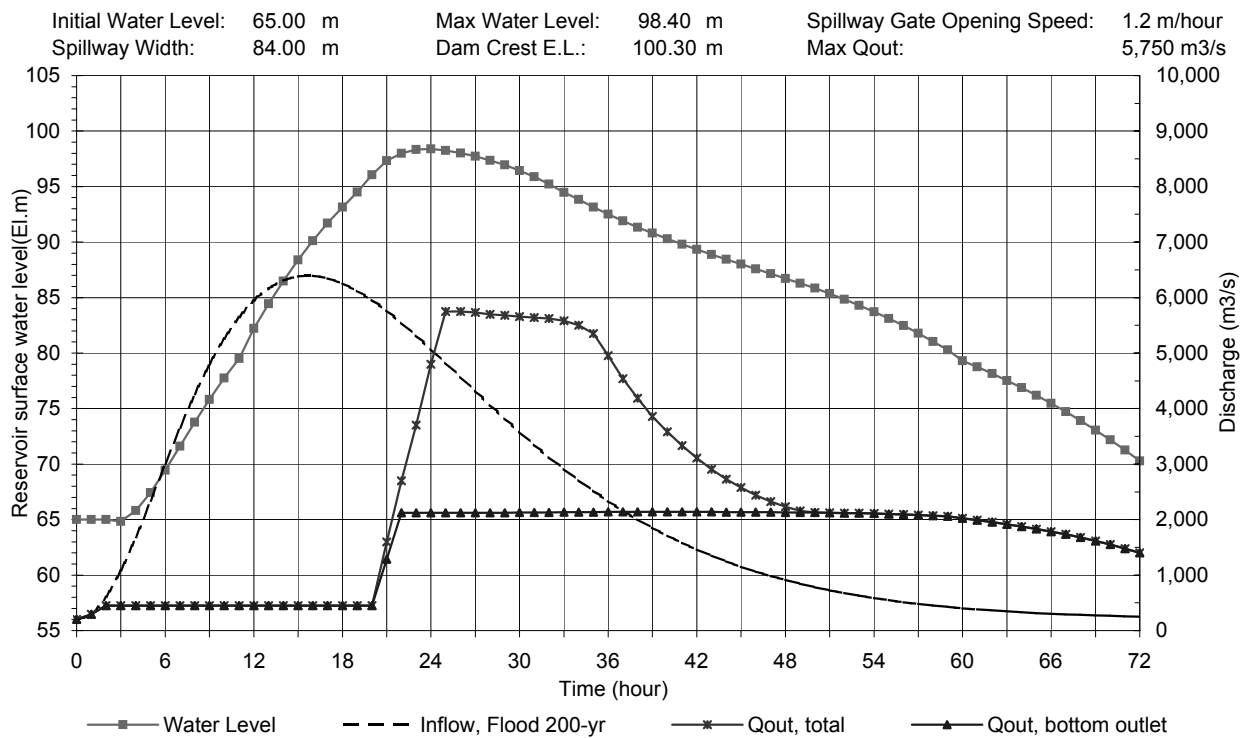

Figure K.11 (4) Flood Routing Curve for Dam with Crest E.L.100.3m
(200-yr Probable Flood, $Q_p=6,397\text{m}^3/\text{s}$, Initial WL=65.00m)

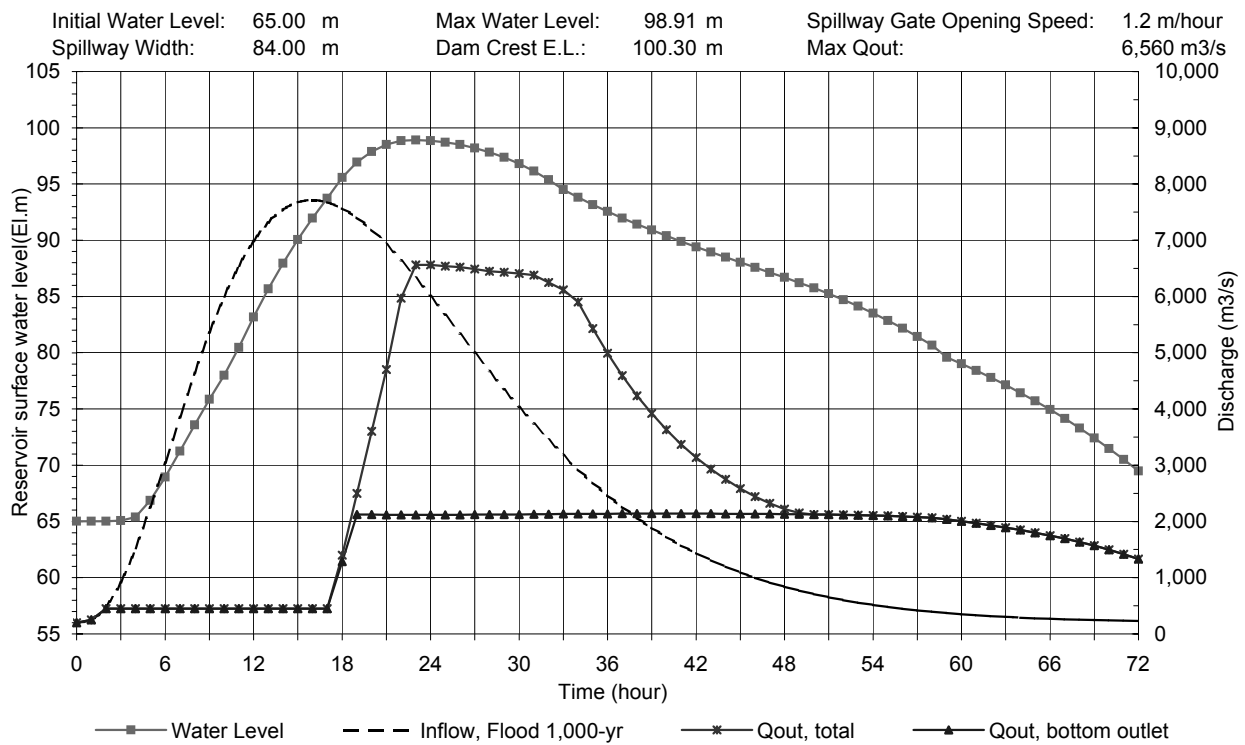

Figure K.11 (5) Flood Routing Curve for Dam with Crest E.L.100.3m
(1,000-yr Probable Flood, $Q_p=7,718\text{m}^3/\text{s}$, Initial WL=65.00m)

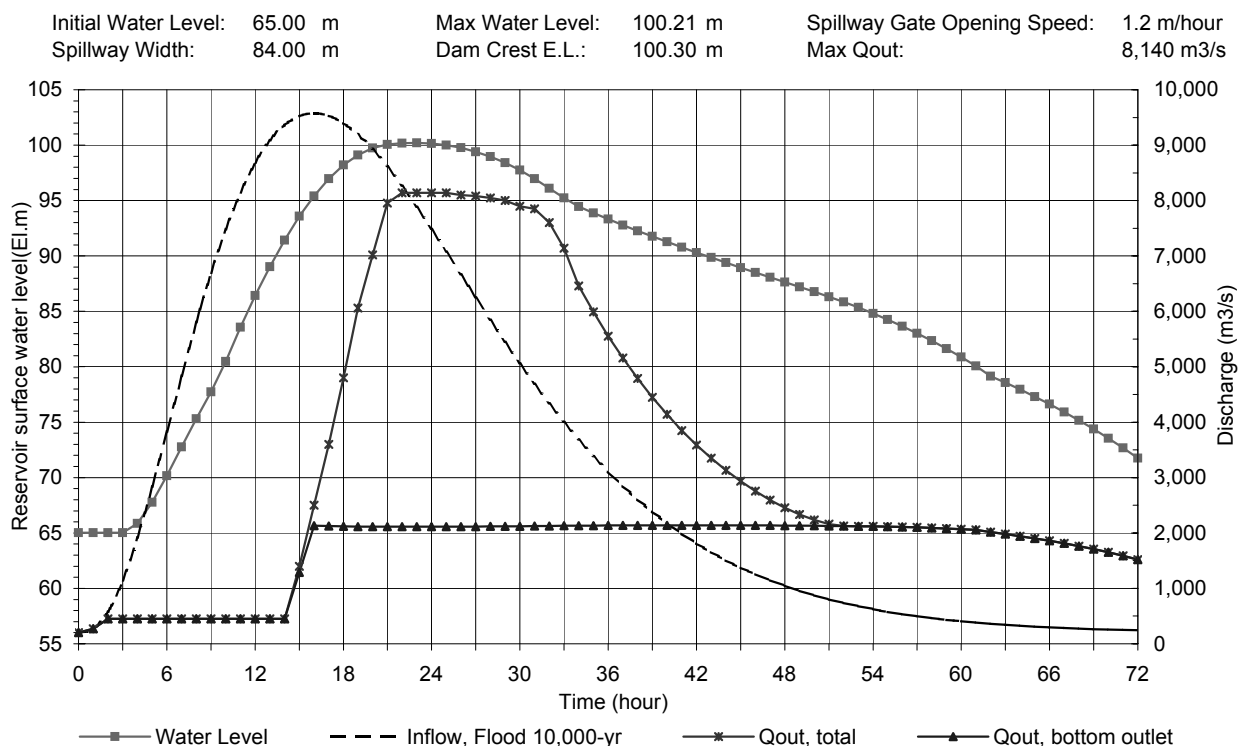

Figure K.11 (6) Flood Routing Curve for Dam with Crest E.L.100.3m
(10,000-yr Probable Flood, $Q_p=9,578\text{m}^3/\text{s}$, Initial WL=65.00m)

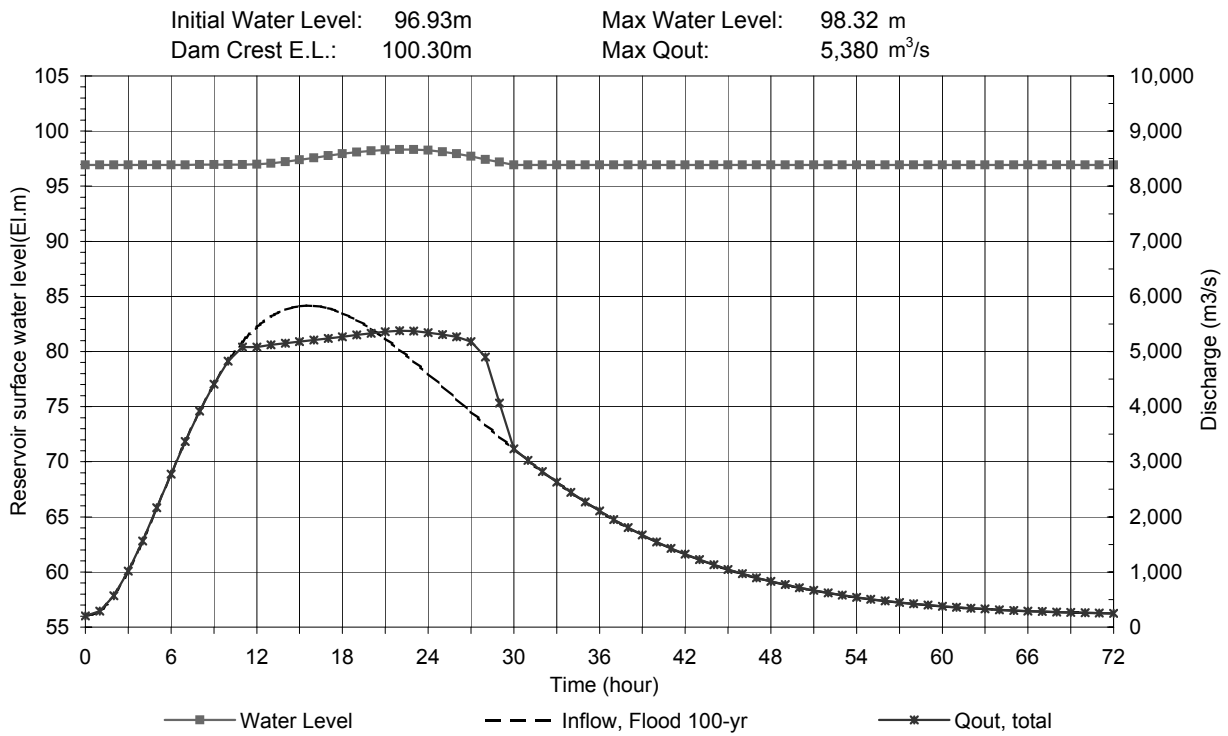

Figure K.11 (7) Flood Routing Curve for Dam with Crest E.L.100.3m
(100-yr Probable Flood, $Q_p=5,832\text{m}^3/\text{s}$, Initial WL=96.93m)

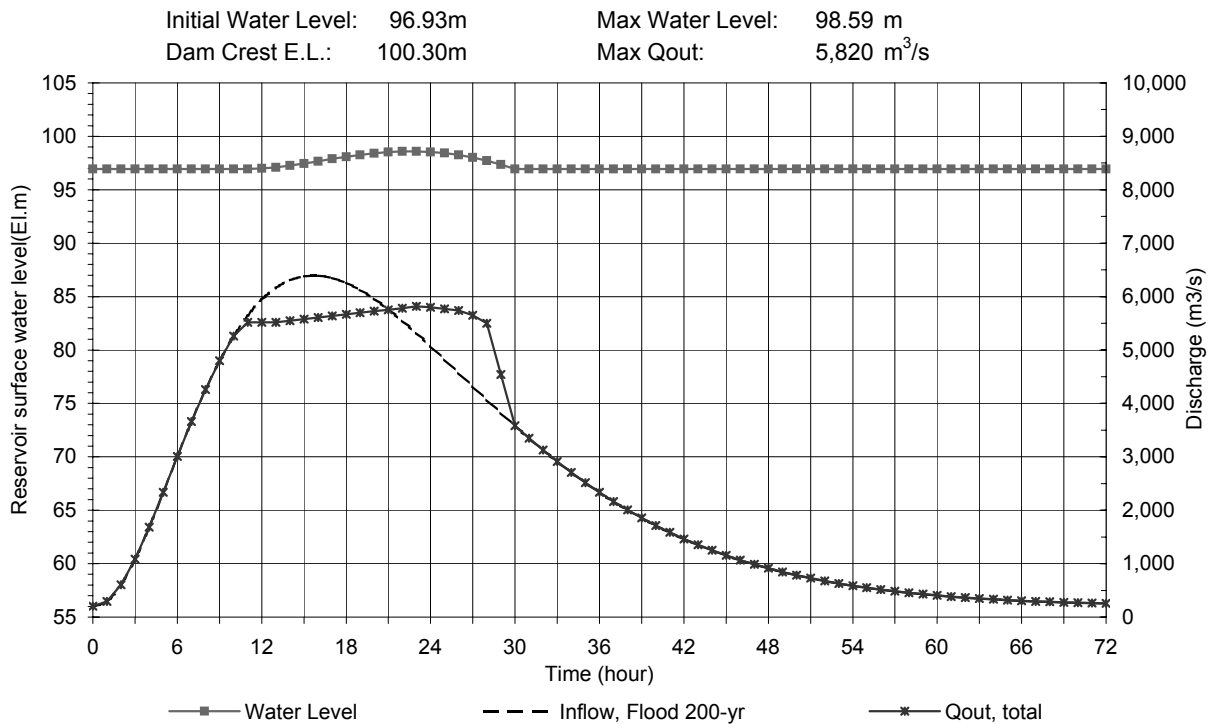

Figure K.11 (8) Flood Routing Curve for Dam with Crest E.L.100.3m
(200-yr Probable Flood, $Q_p=6,394\text{m}^3/\text{s}$, Initial WL=96.93m)

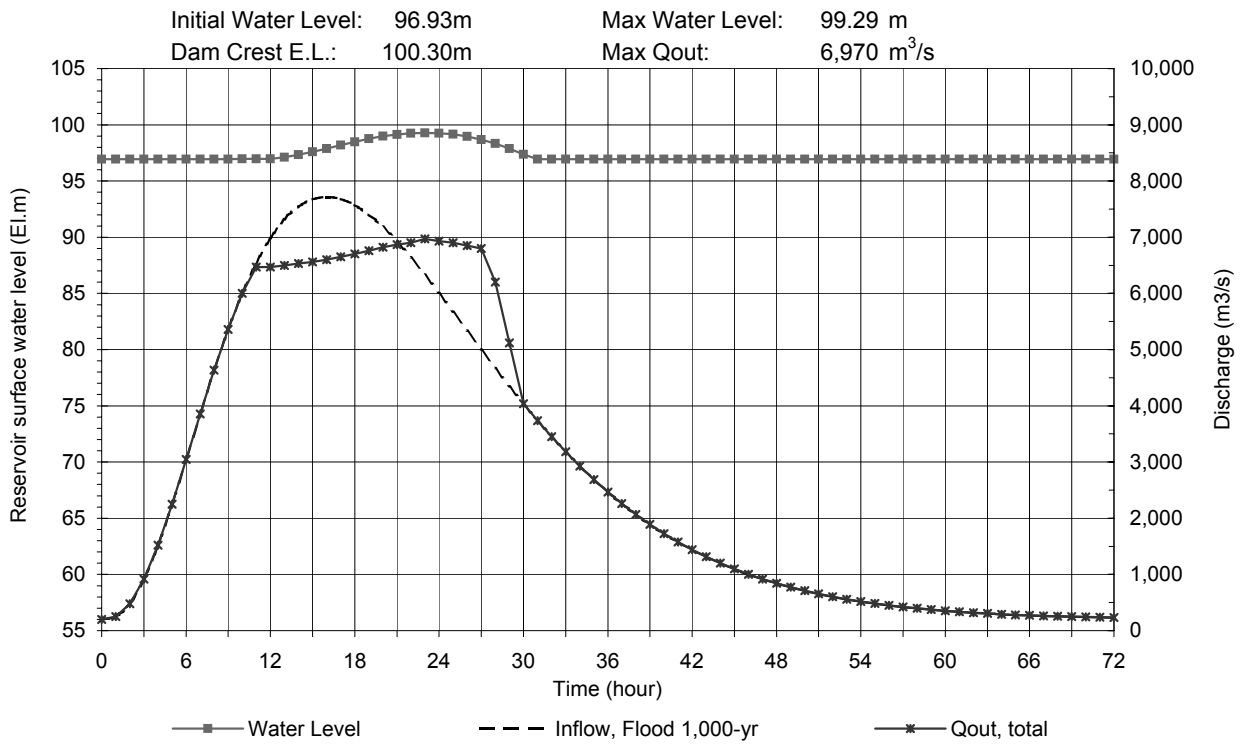

Figure K.11 (9) Flood Routing Curve for Dam with Crest E.L.100.3m
 (1,000-yr Probable Flood, $Q_p=7,718\text{m}^3/\text{s}$, Initial WL=96.93m)

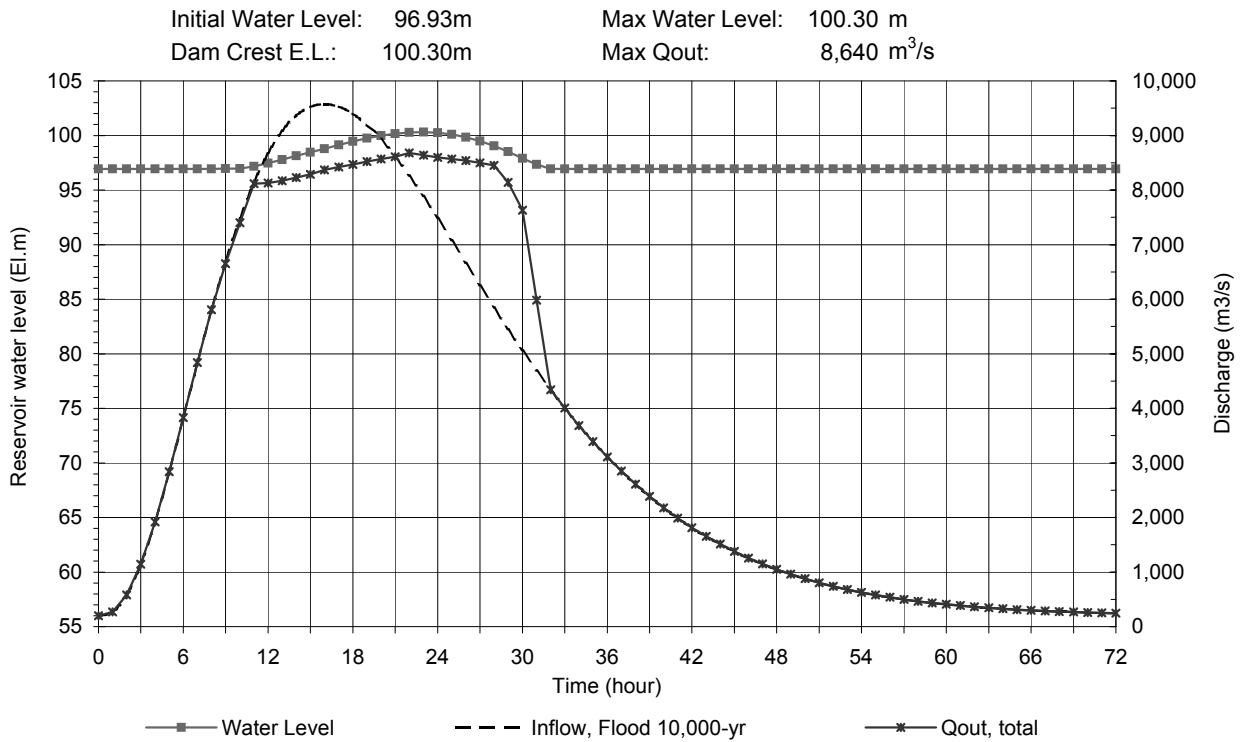

Figure K.11 (10) Flood Routing Curve for Dam with Crest E.L.100.3m
 (10,000-yr Probable Flood, $Q_p=9,578\text{m}^3/\text{s}$, Initial WL=96.93m)

KF-20

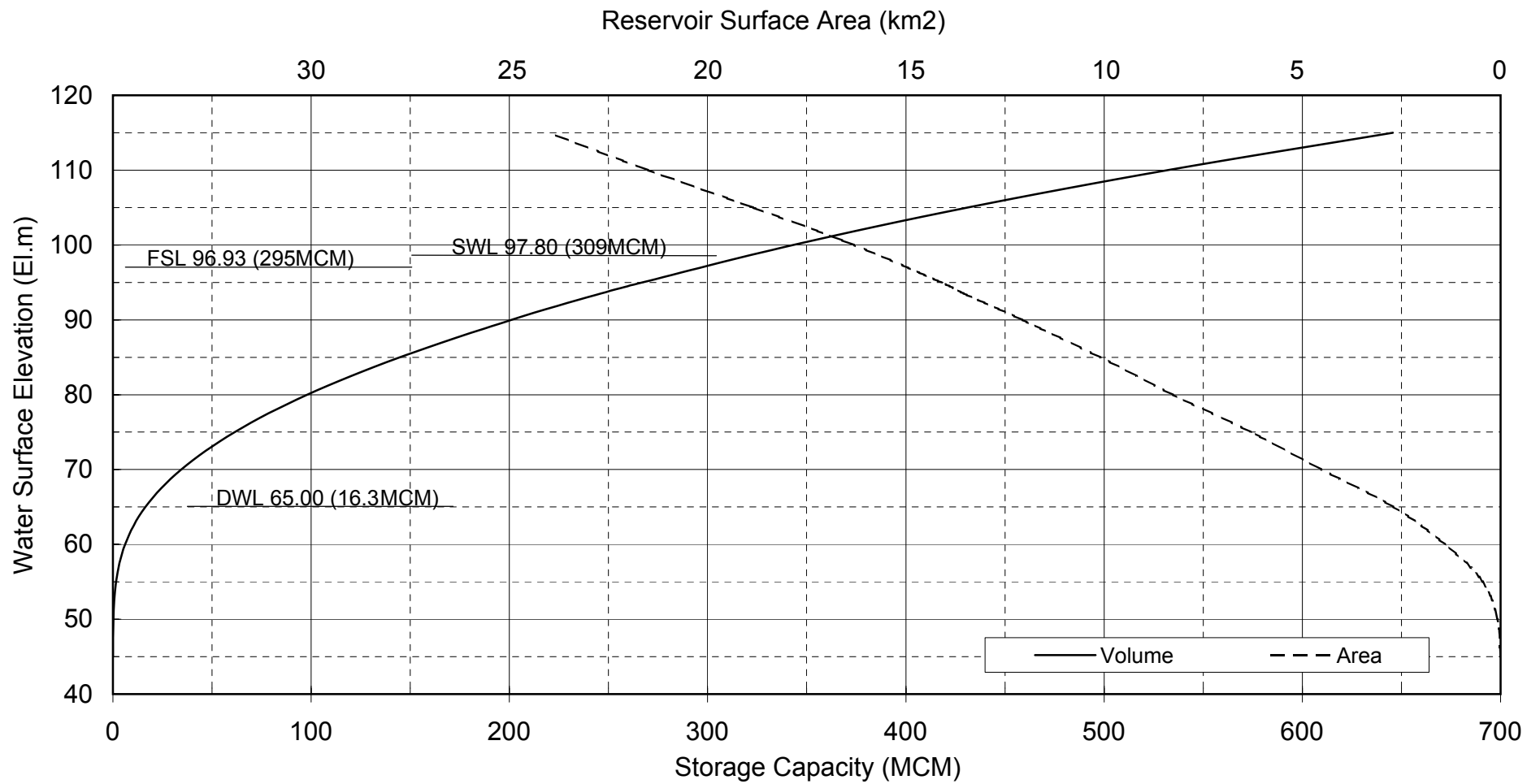

Figure K.12 Reservoir Storage Capacity and Surface Area of Dinh Binh Reservoir (Site I)

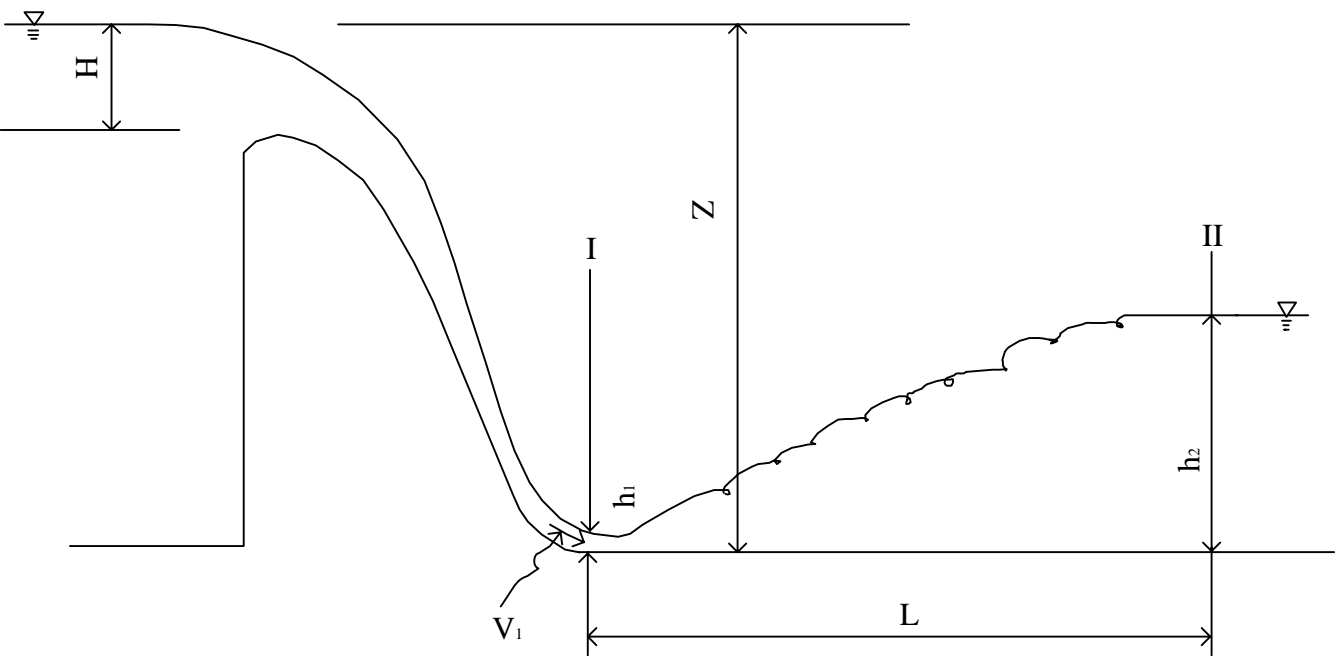

Figure K.13 Symbols in Calculation of Hydraulic Jump

The Study on Nationwide Water Resources Development and Management in the Socialist Republic of Vietnam

JAPAN INTERNATIONAL COOPERATION AGENCY

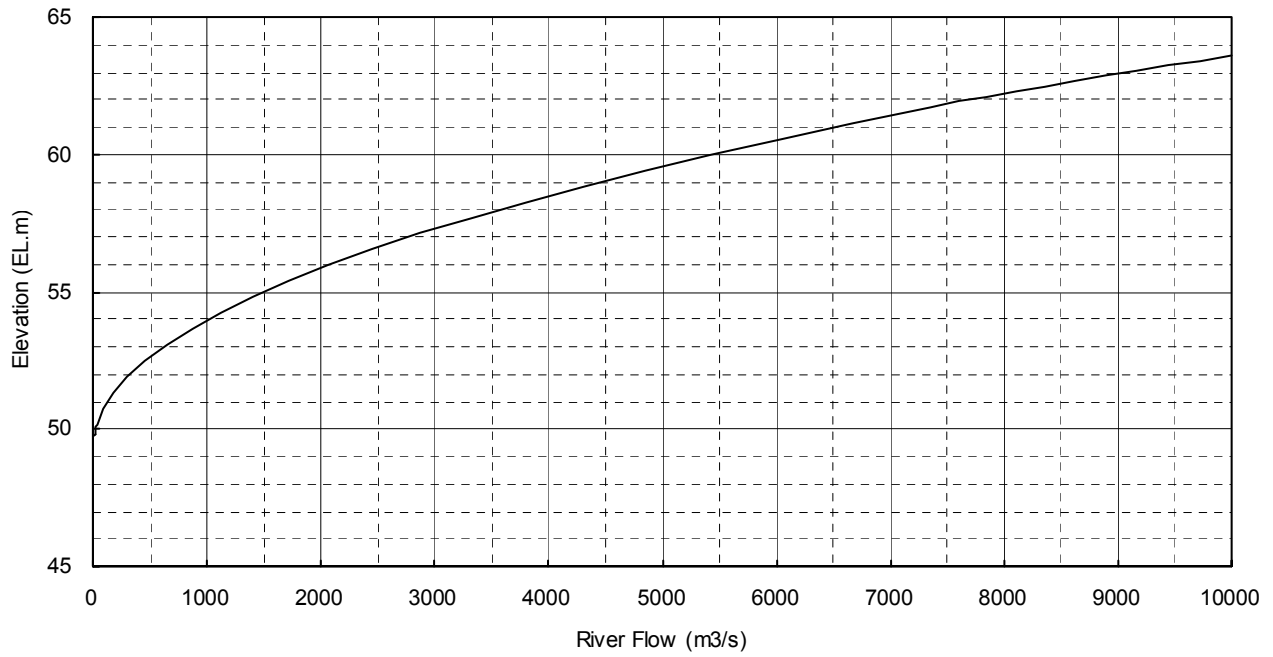

Figure K.14 Tailwater Rating Curve at Dinh Binh Dam Site

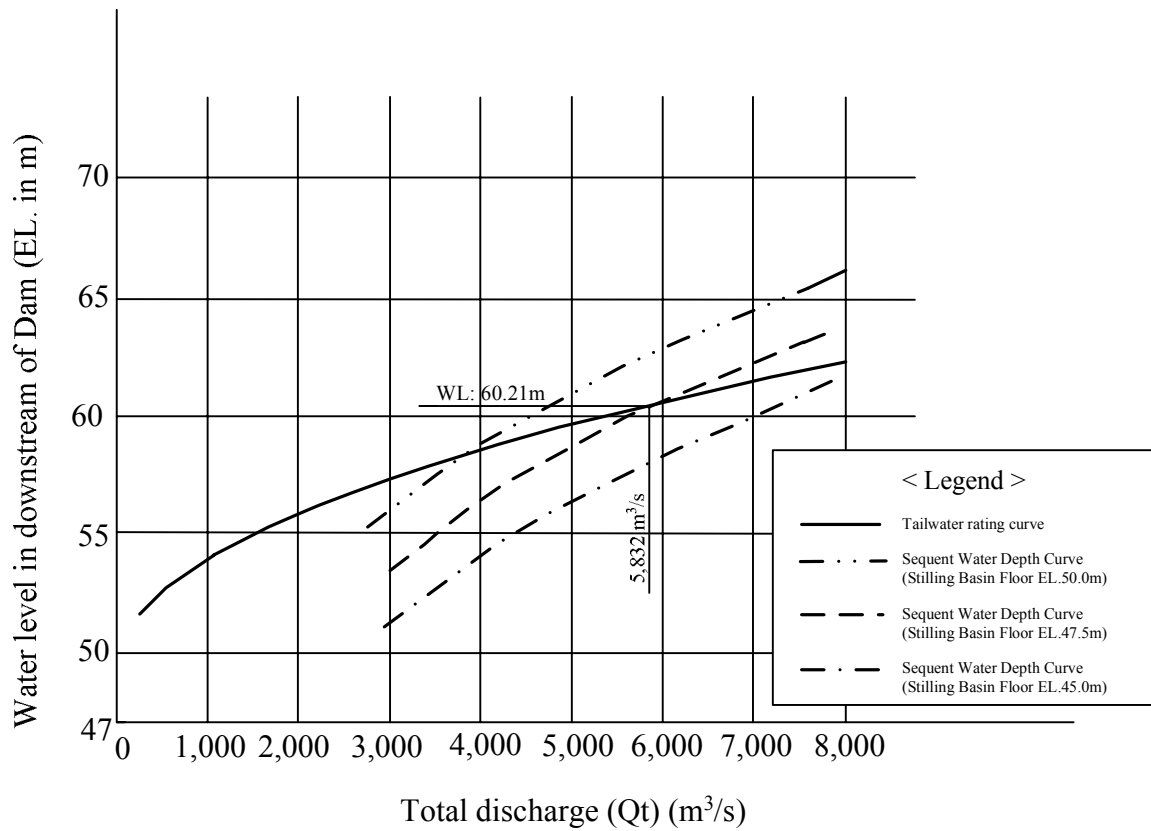
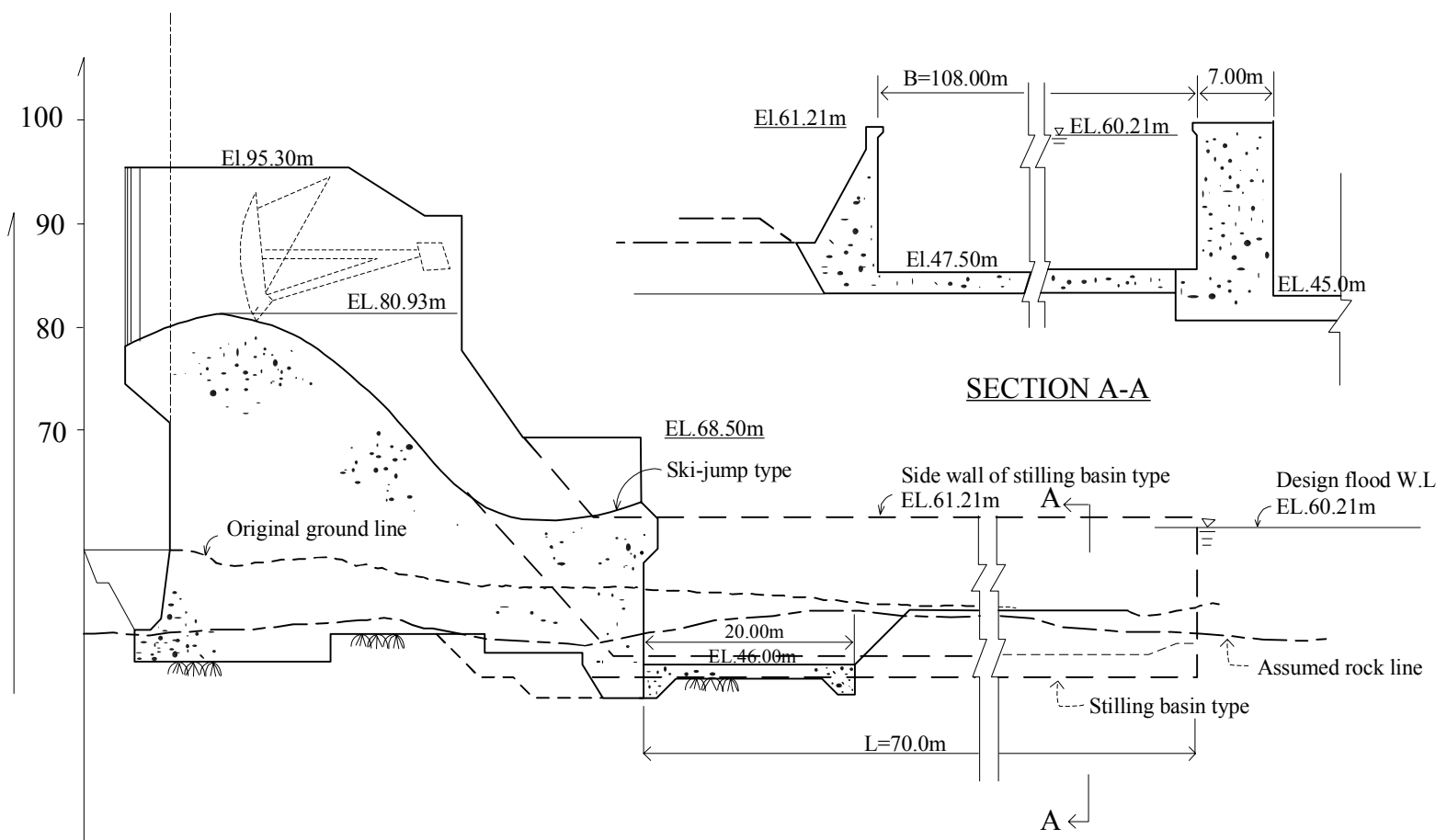

Figure K.15 Relation among Stilling Basin Flood Level, Sequent Water Level and Tailwater Rating Curve



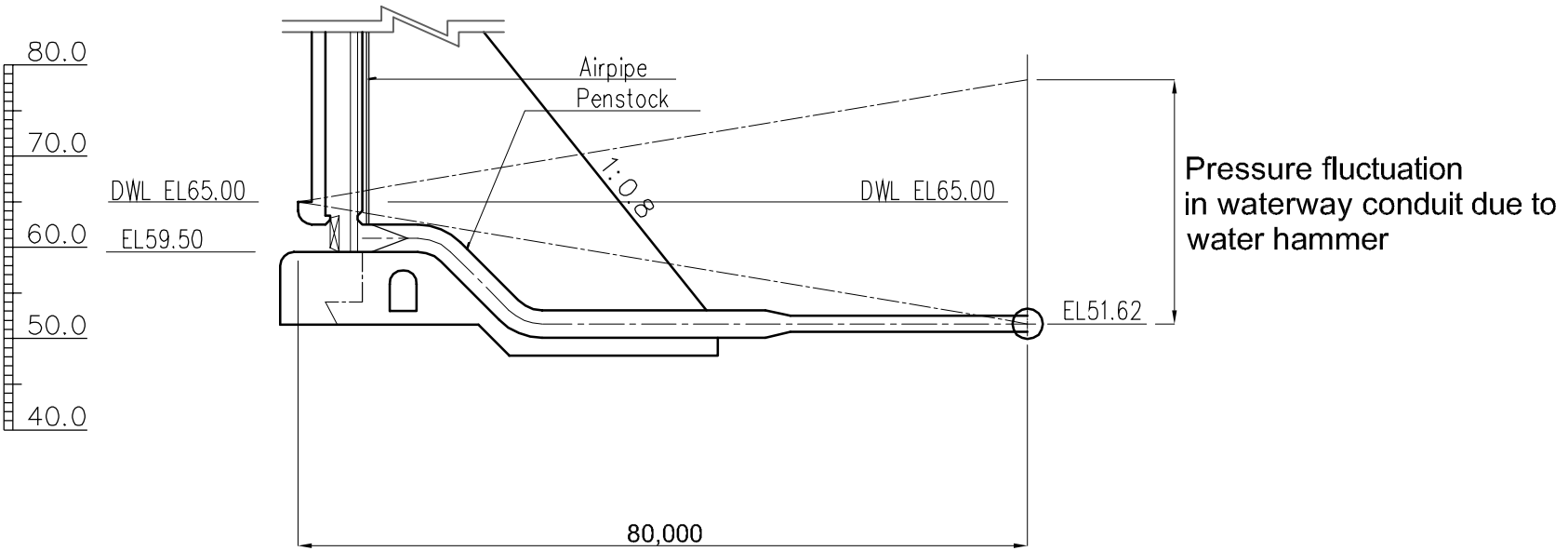
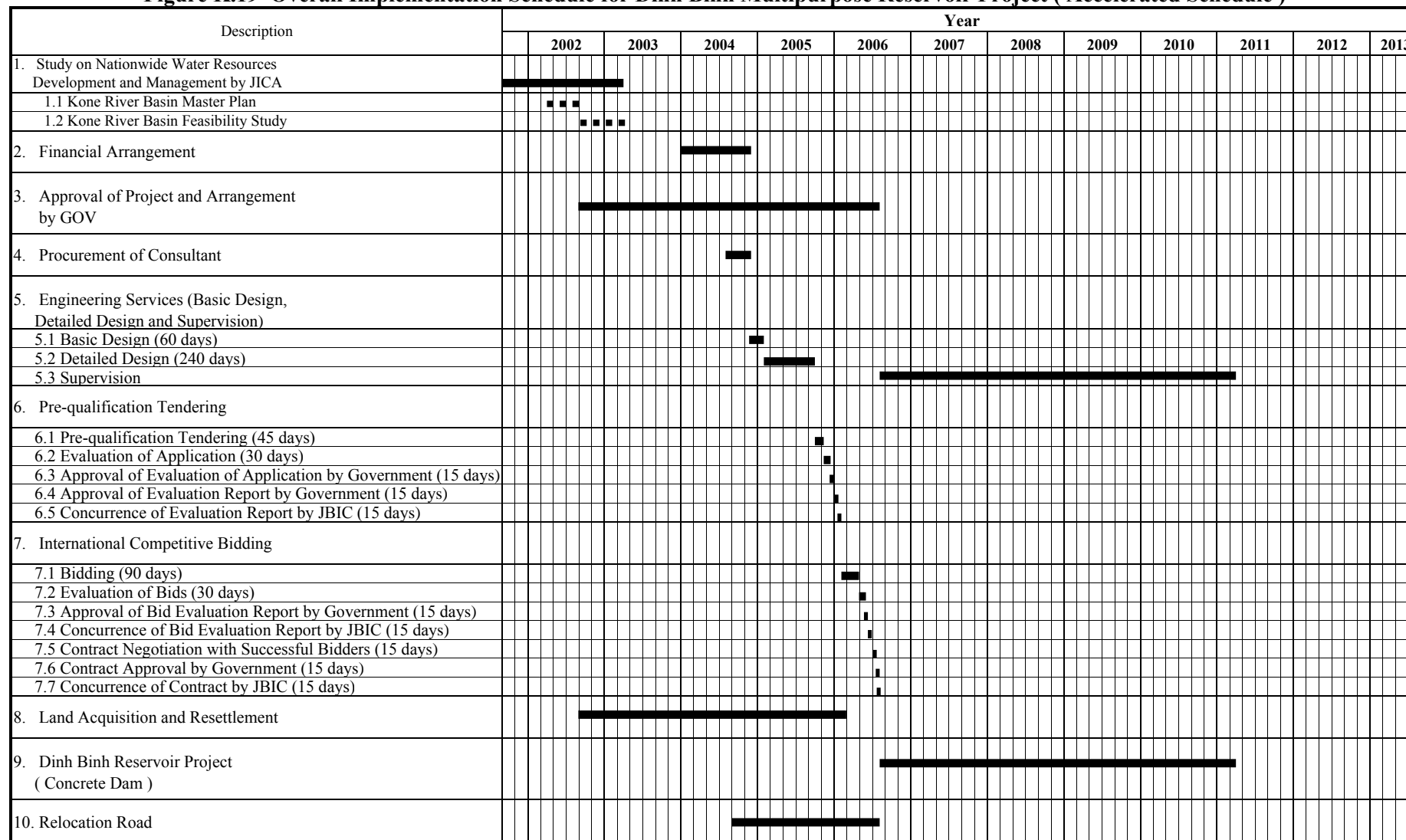

Figure K.19 Overall Implementation Schedule for Dinh Binh Multipurpose Reservoir Project (Accelerated Schedule)



KF-26

