

The Study on Nationwide Water Resources
Development and Management
in the Socialist Republic of Vietnam

JAPAN INTERNATIONAL COOPERATION AGENCY

Figure 5.4
Locations of Salinity Measurement and
Intrusion Control Weir

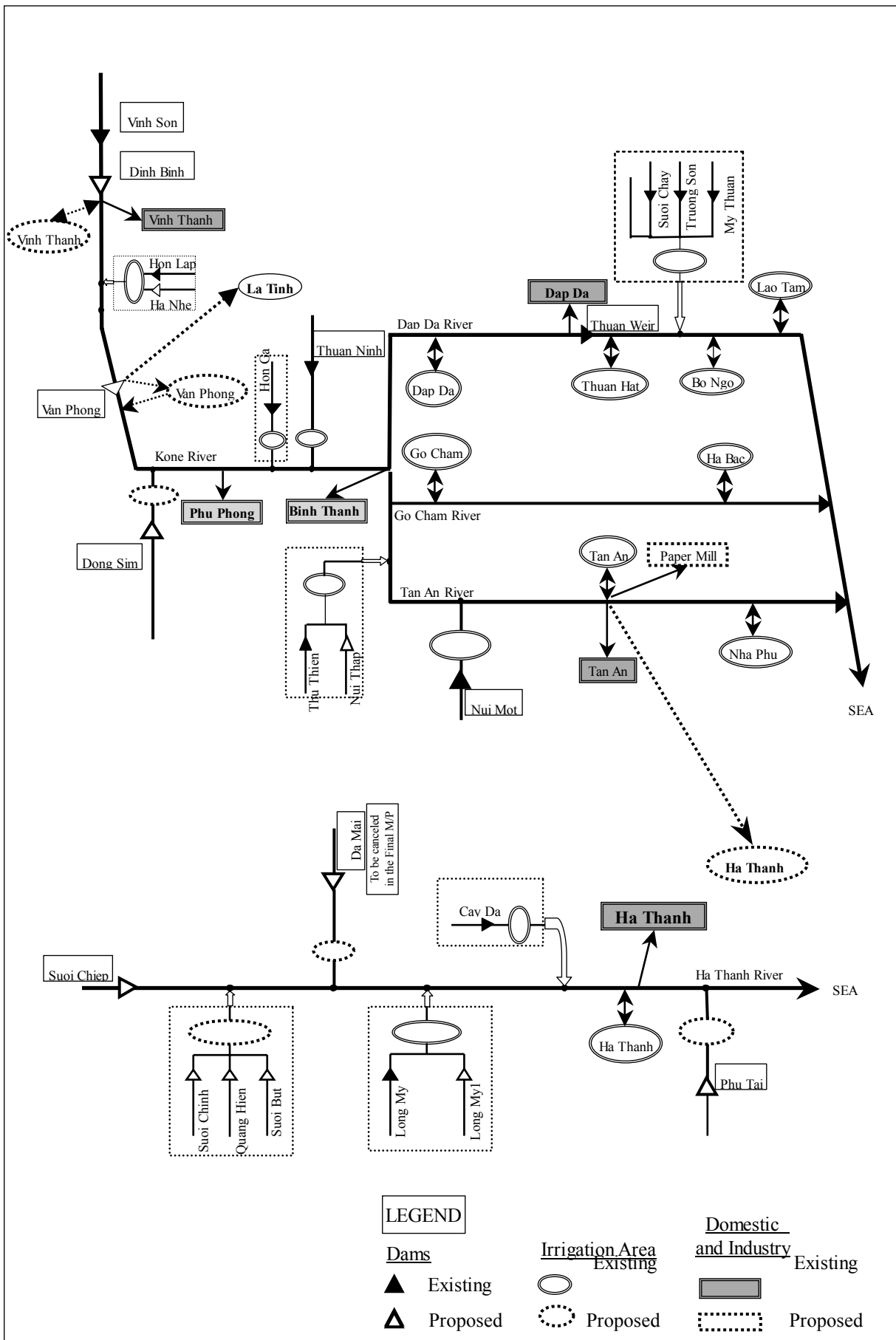

The Study on Nationwide Water Resources Development and Management in the Socialist Republic of Vietnam
 JAPAN INTERNATIONAL COOPERATION AGENCY

Figure 6.1
Schematic Model of Water Balance Analysis

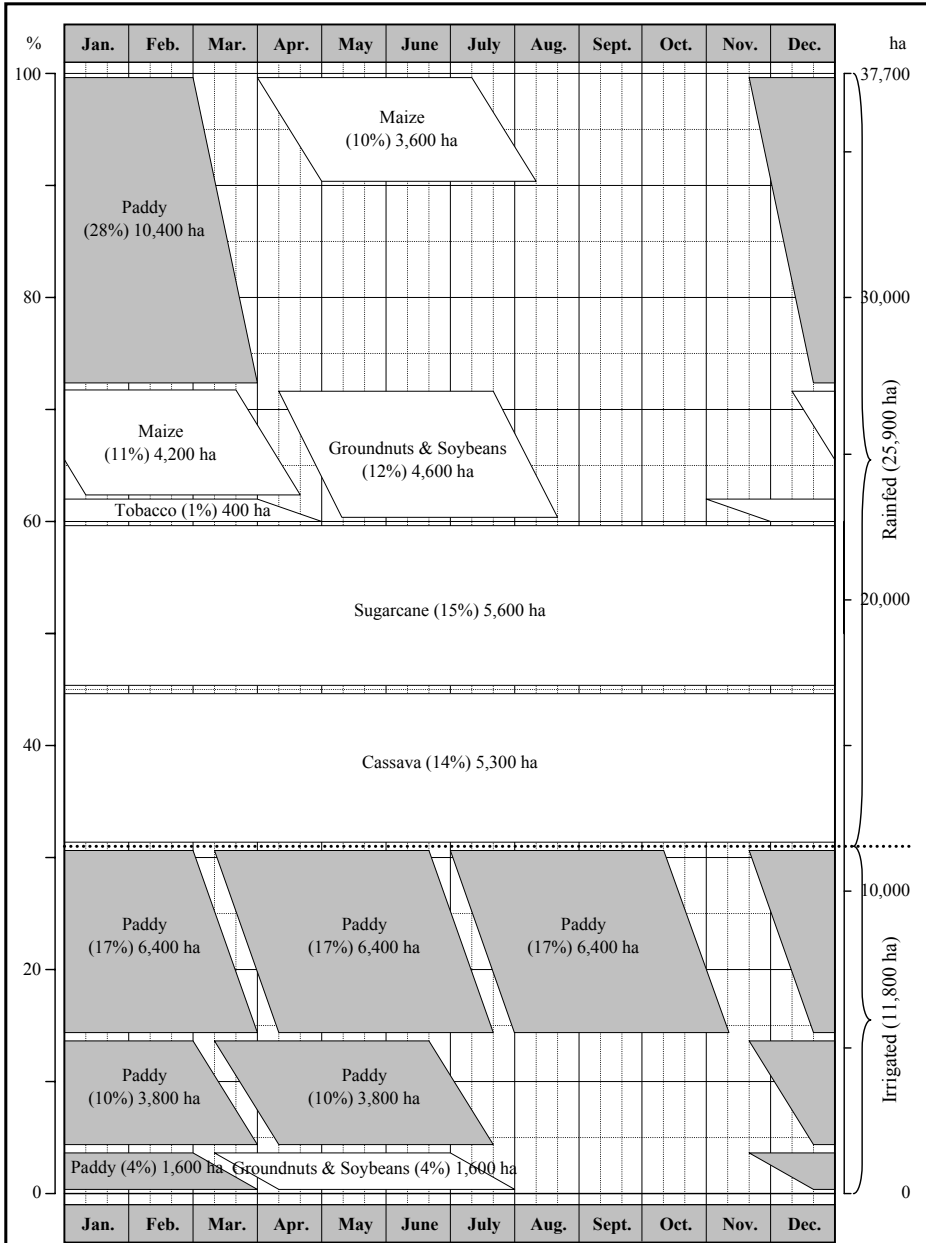

Figure 7.1 Cropping Pattern in the Project Area of Master Plan (1/8) Present Cropping Pattern A (Higher Position)

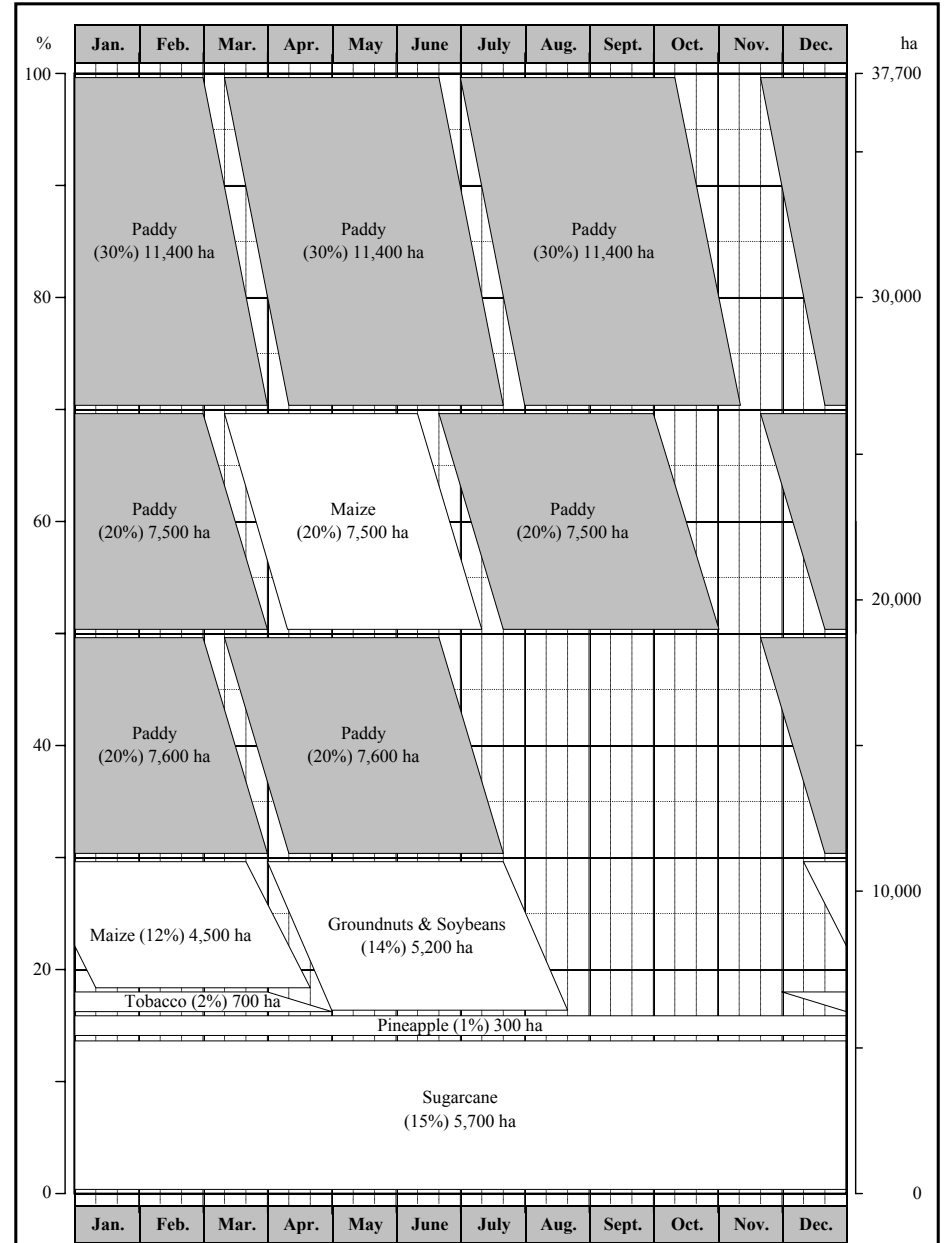

Figure 7.1 Cropping Pattern in the Project Area of Master Plan (2/8) Future Cropping Pattern A (Higher Position)

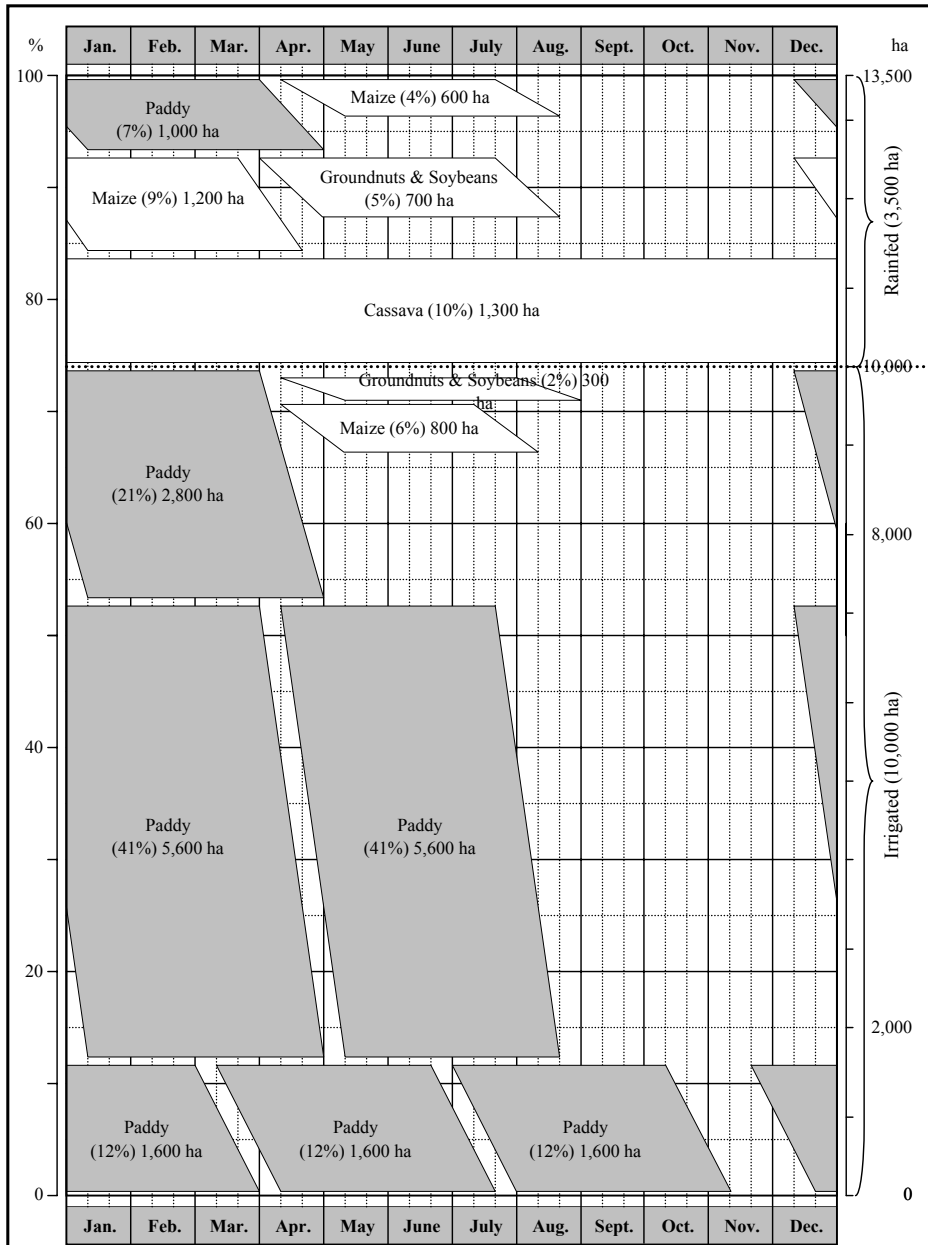

Figure 7.1 Cropping Pattern in the Project Area of Master Plan (3/8)
Present Cropping Pattern B (Middle Position)

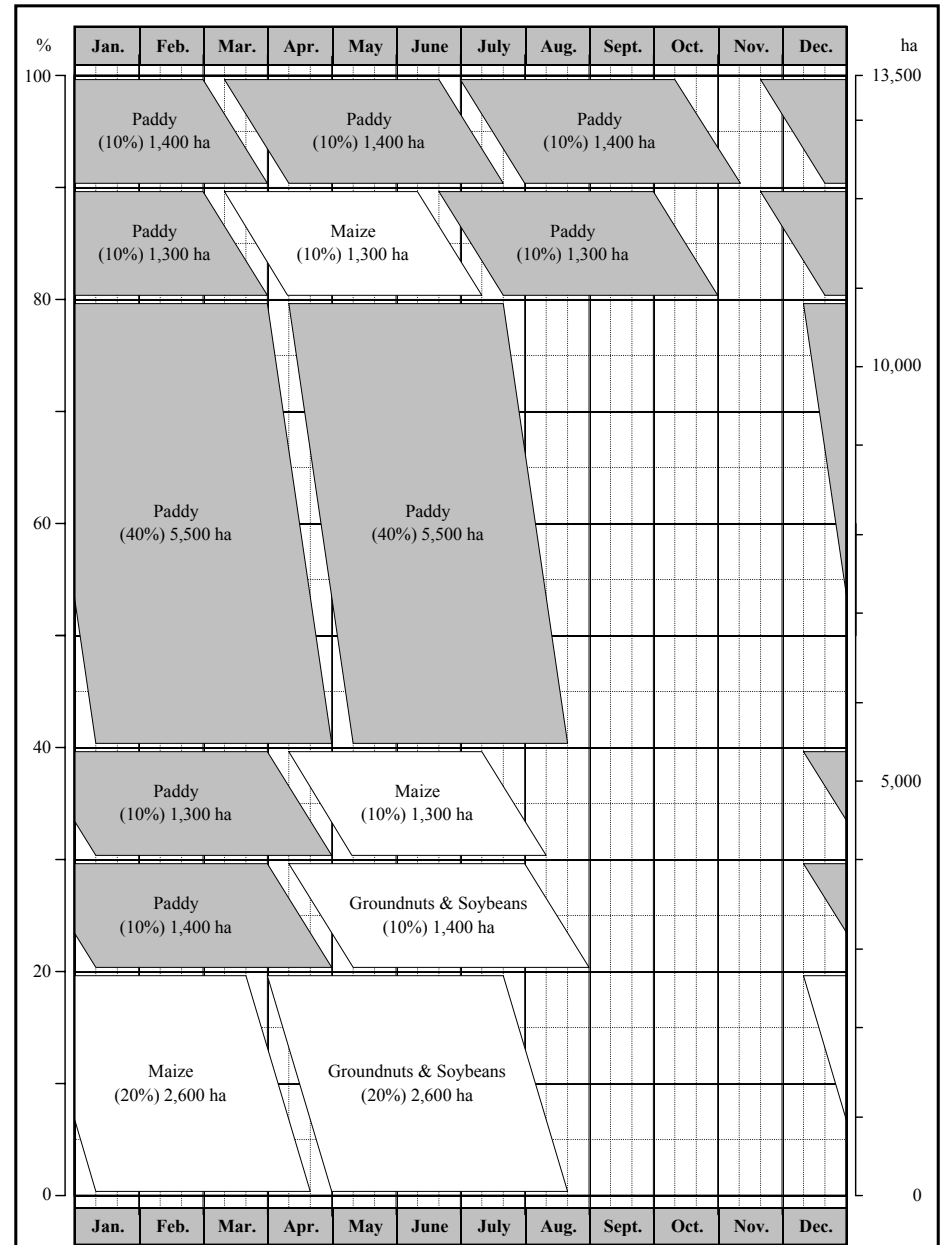

Figure 7.1 Cropping Pattern in the Project Area of Master Plan (4/8)
Future Cropping Pattern B (Middle Position)

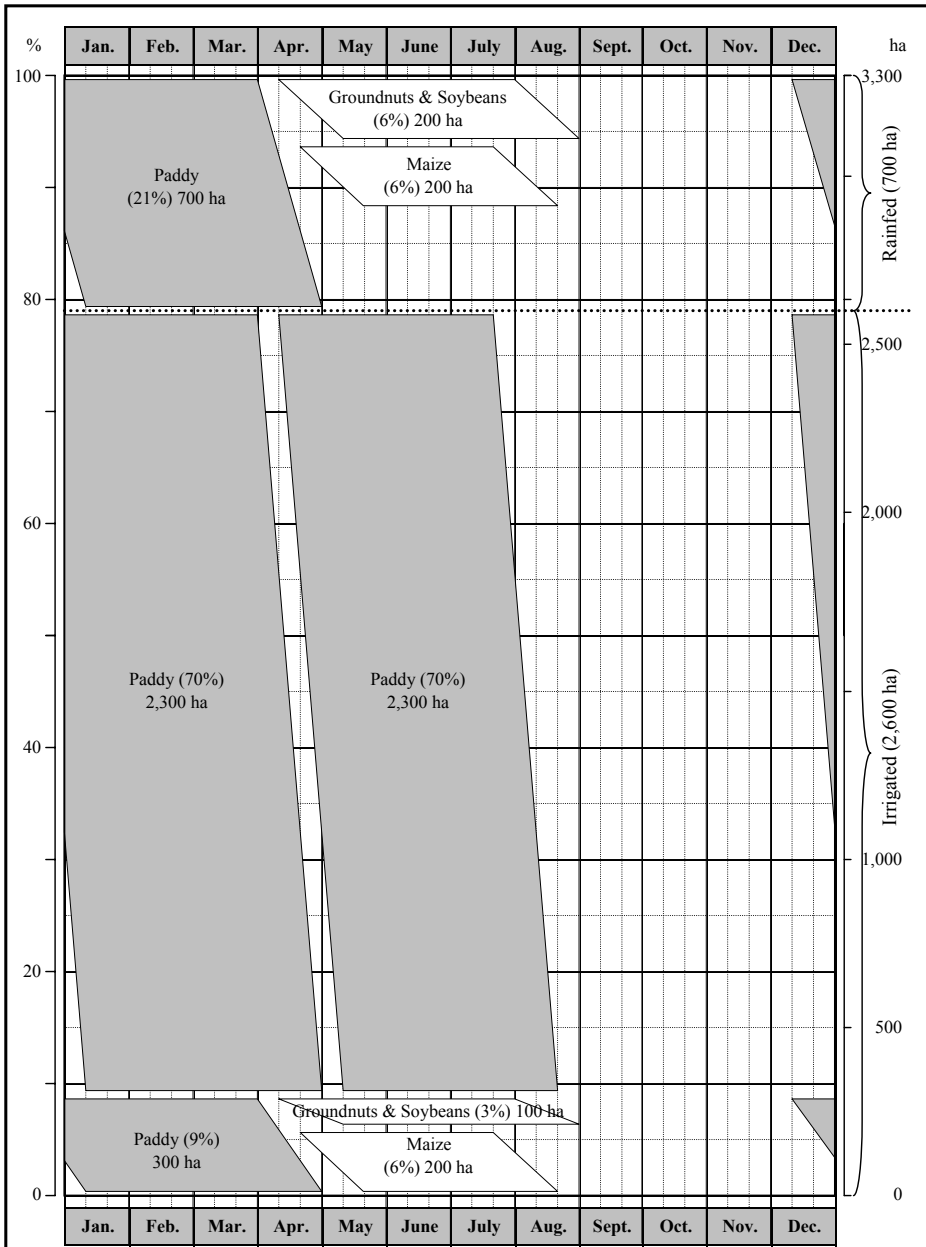

Figure 7.1 Cropping Pattern in the Project Area of Master Plan (5/8)
Present Cropping Pattern C (Lower Position)

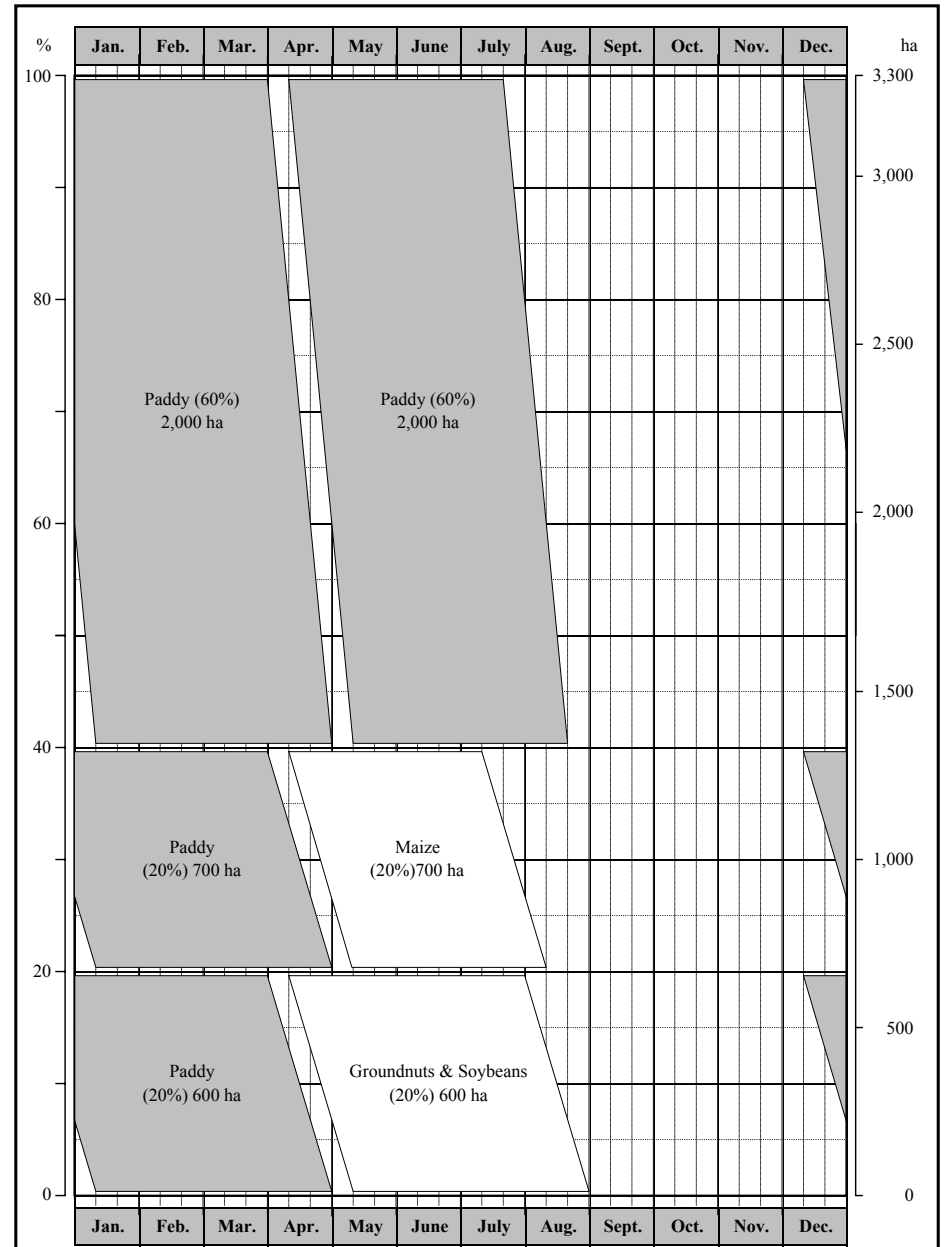

Figure 7.1 Cropping Pattern in the Project Area of Master Plan (6/8)
Future Cropping Pattern C (Lower Position)

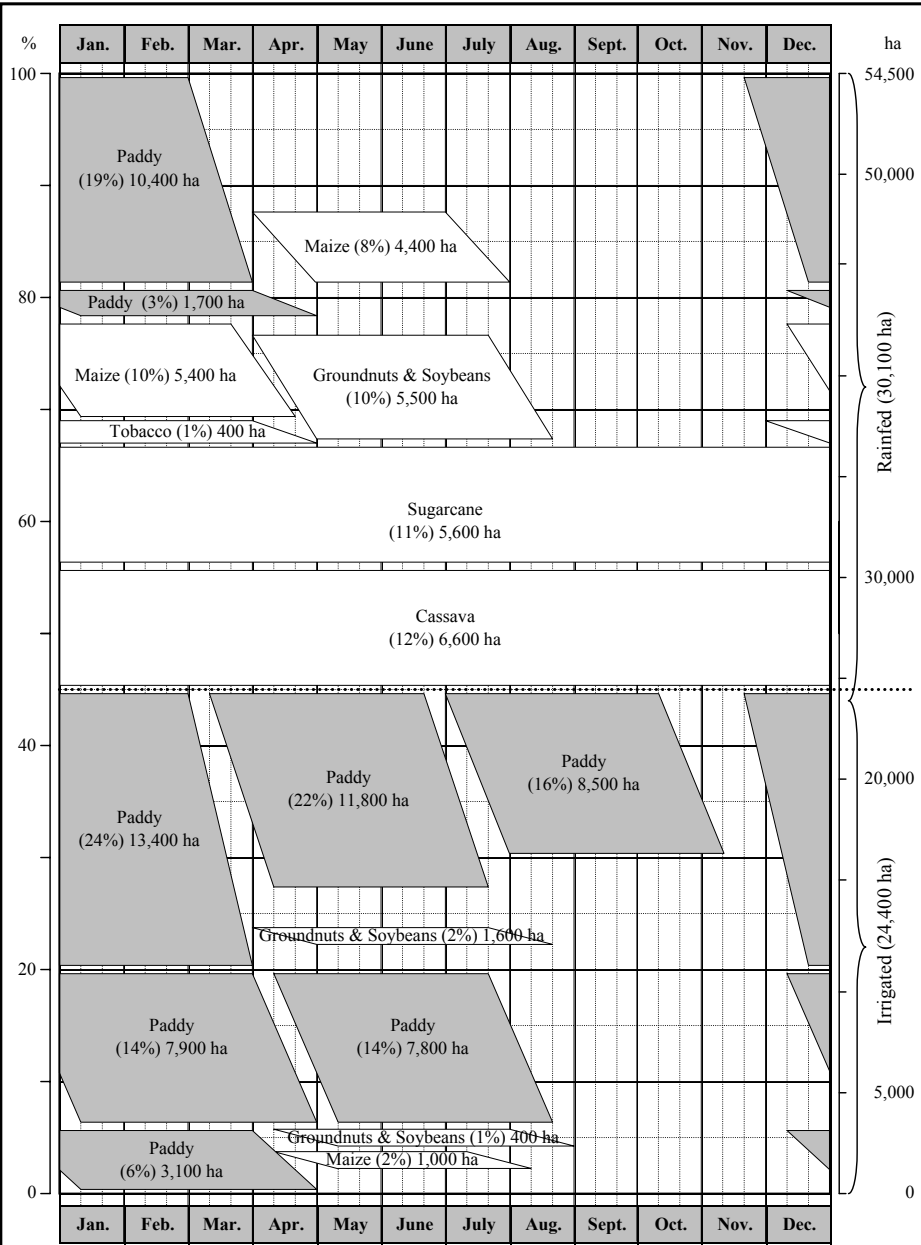

Figure 7.1 Cropping Pattern in the Project Area of Master Plan (7/8)
Present Cropping Pattern (Entire Project Area)

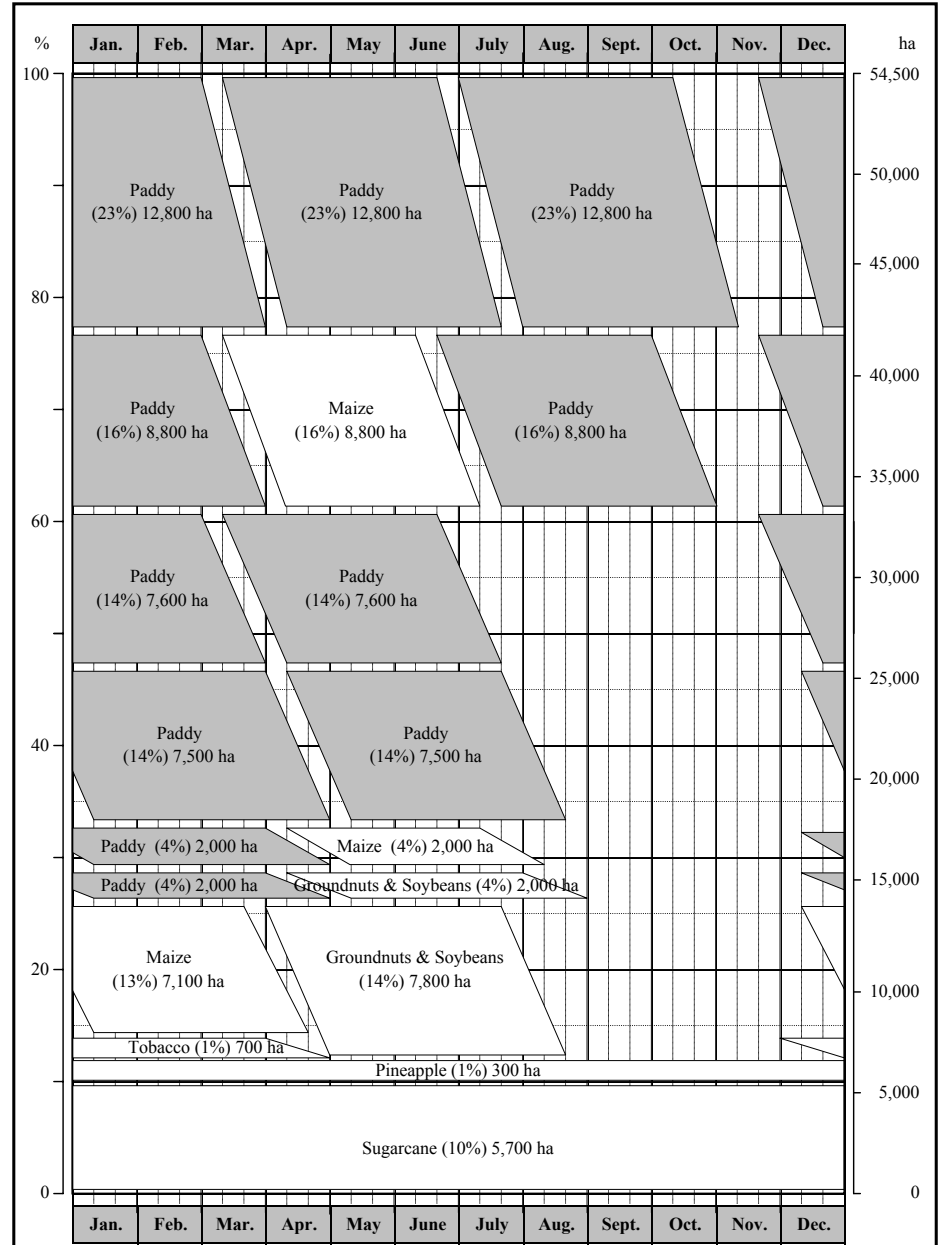
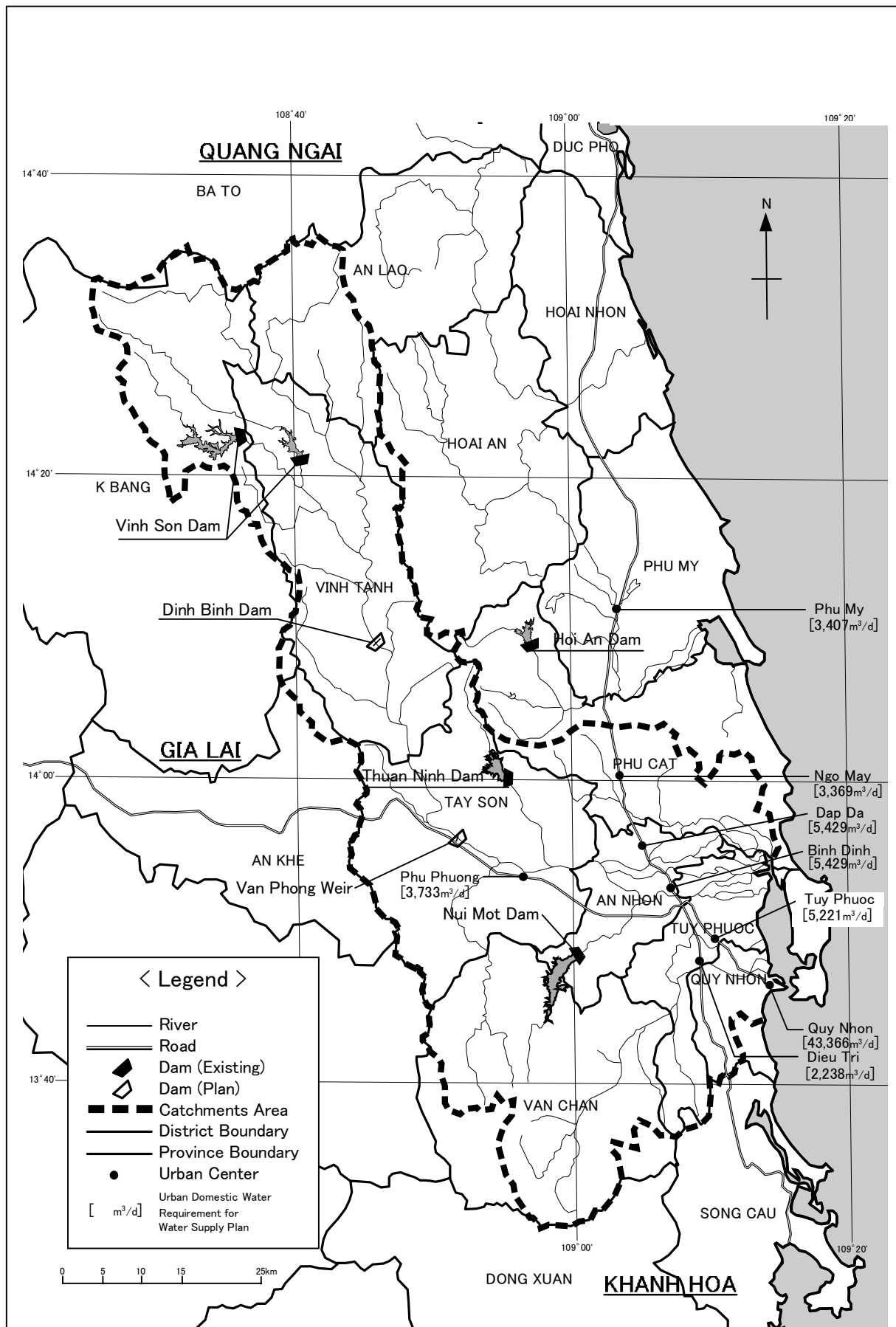

Figure 7.1 Cropping Pattern in the Project Area of Master Plan (8/8)
Future Cropping Pattern (Entire Project Area)



The Study on Nationwide Water Resources
Development and Management
in the Socialist Republic of Vietnam

JAPAN INTERNATIONAL COOPERATION AGENCY

Figure 7.2
**Urban Domestic Water Supply Requirement
for Water Supply Plan**

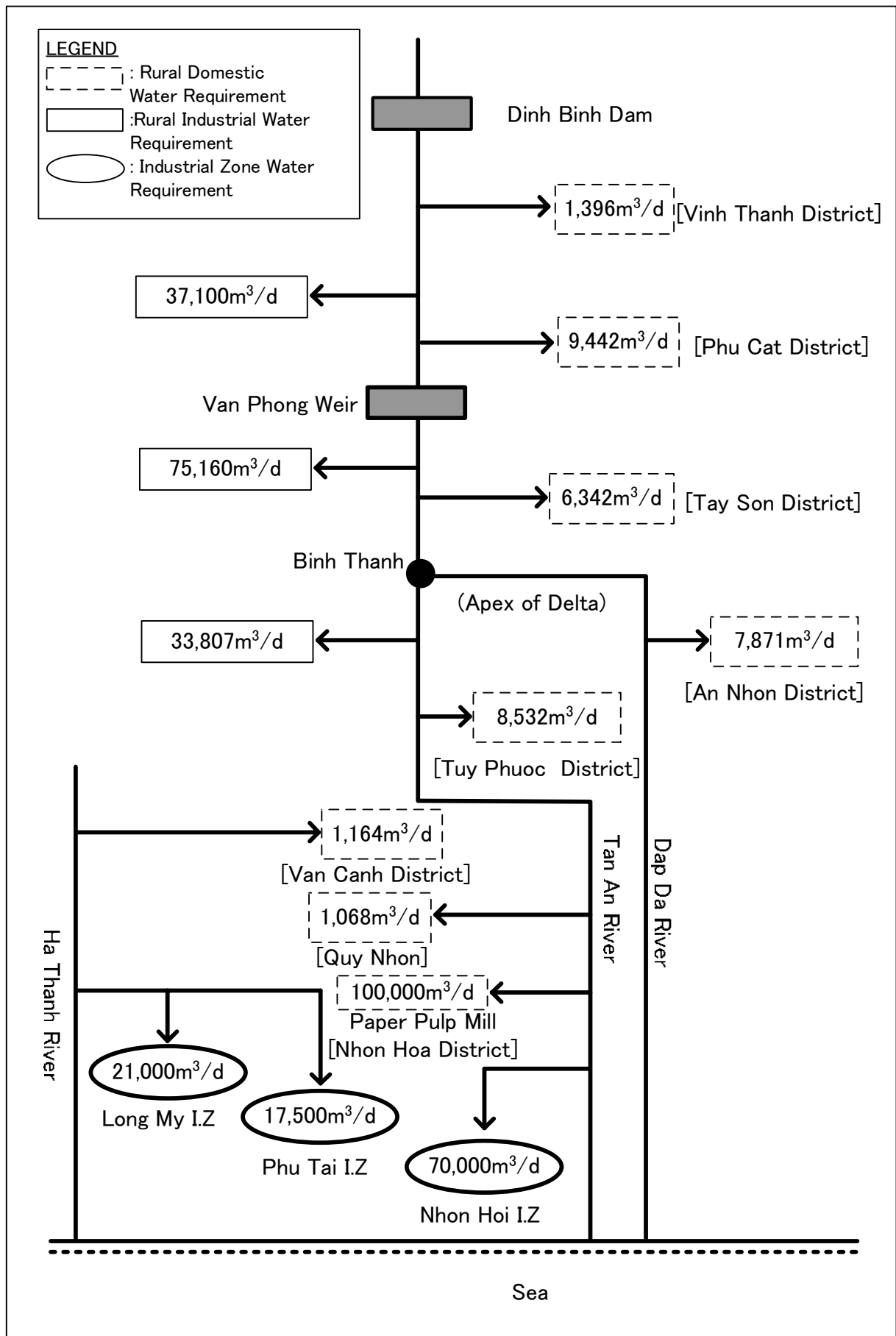

The Study on Nationwide Water Resources
Development and Management
in the Socialist Republic of Vietnam

JAPAN INTERNATIONAL COOPERATION AGENCY

Figure 7.3

**Schematic Presentation of Water Requirement for Rural
Domestic and Industrial Water Supply Plan in 2020**

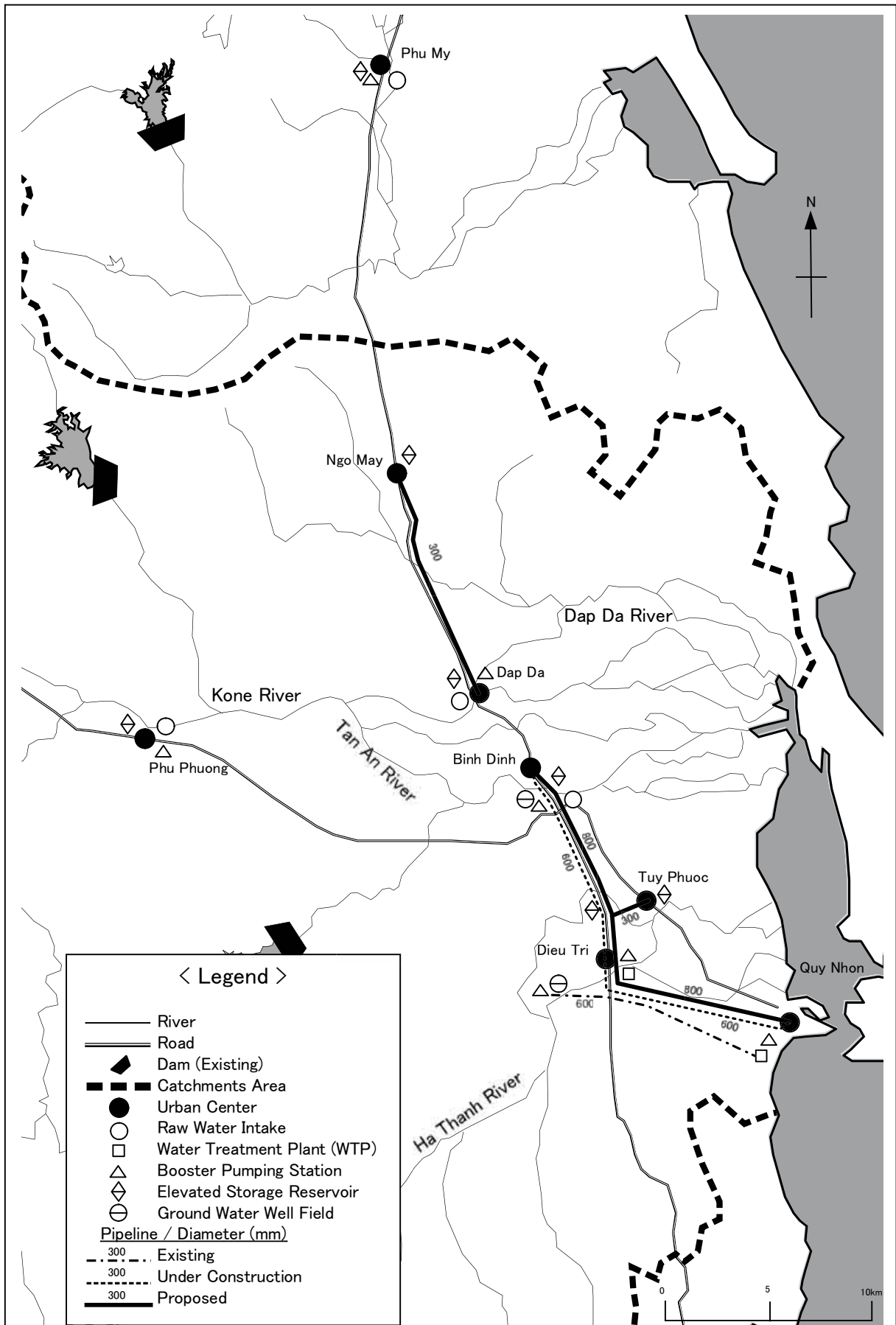

The Study on Nationwide Water Resources
Development and Management
in the Socialist Republic of Vietnam

JAPAN INTERNATIONAL COOPERATION AGENCY

Figure 7.4
**Layout Design of Urban Domestic Water
Supply Plan**

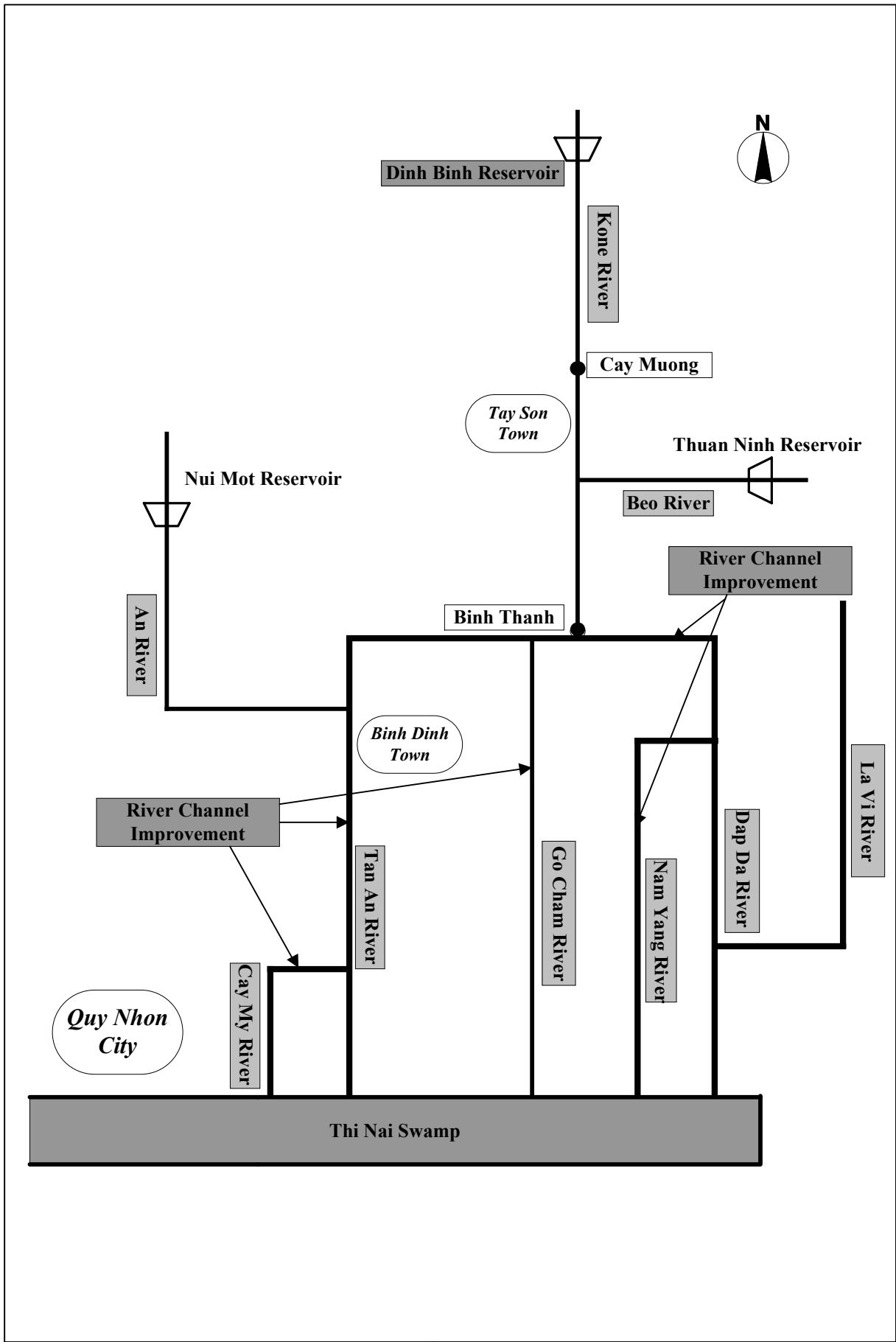

Figure 7.5
Distribution of Flood Control Facilities of
Kone River

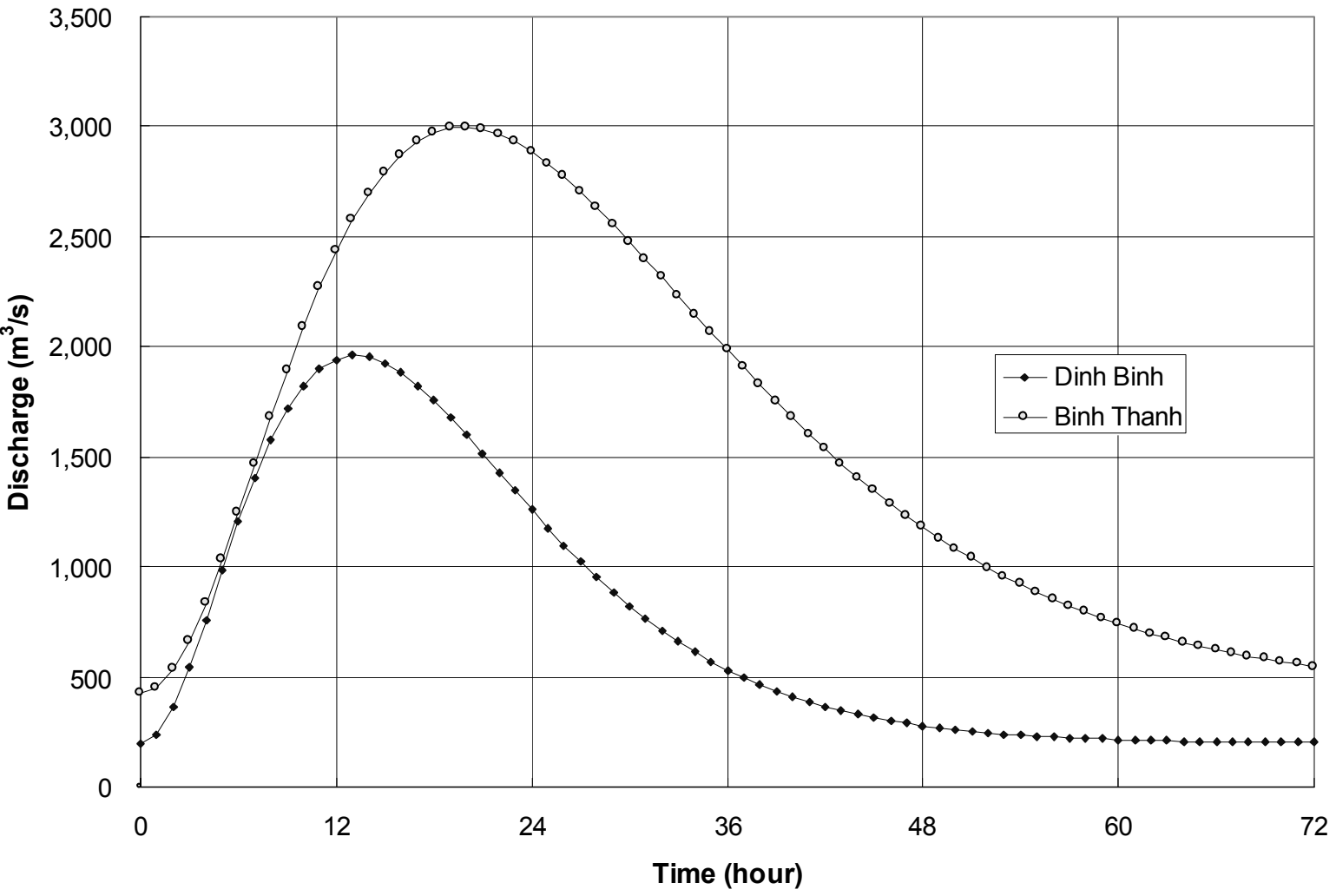
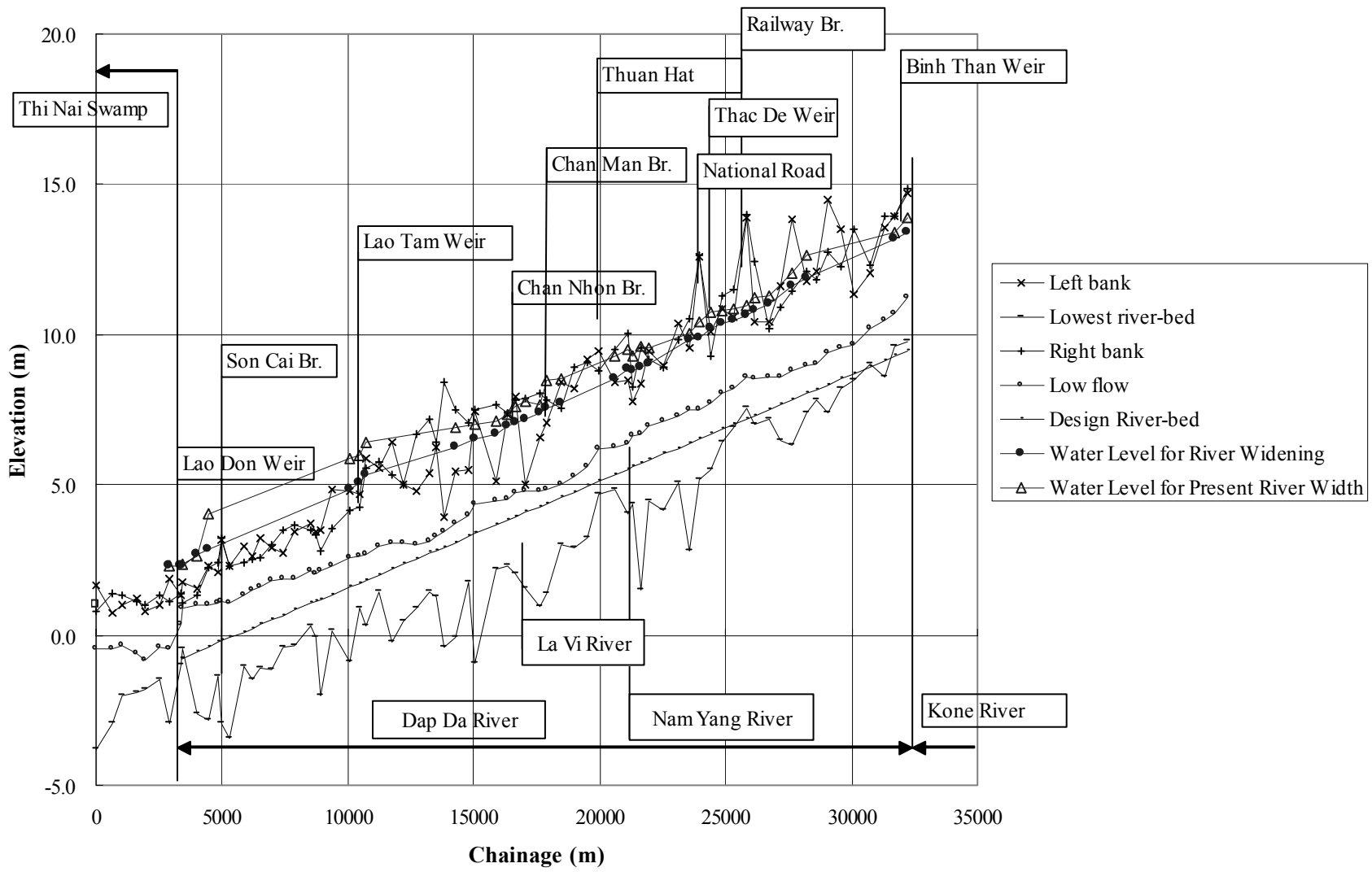
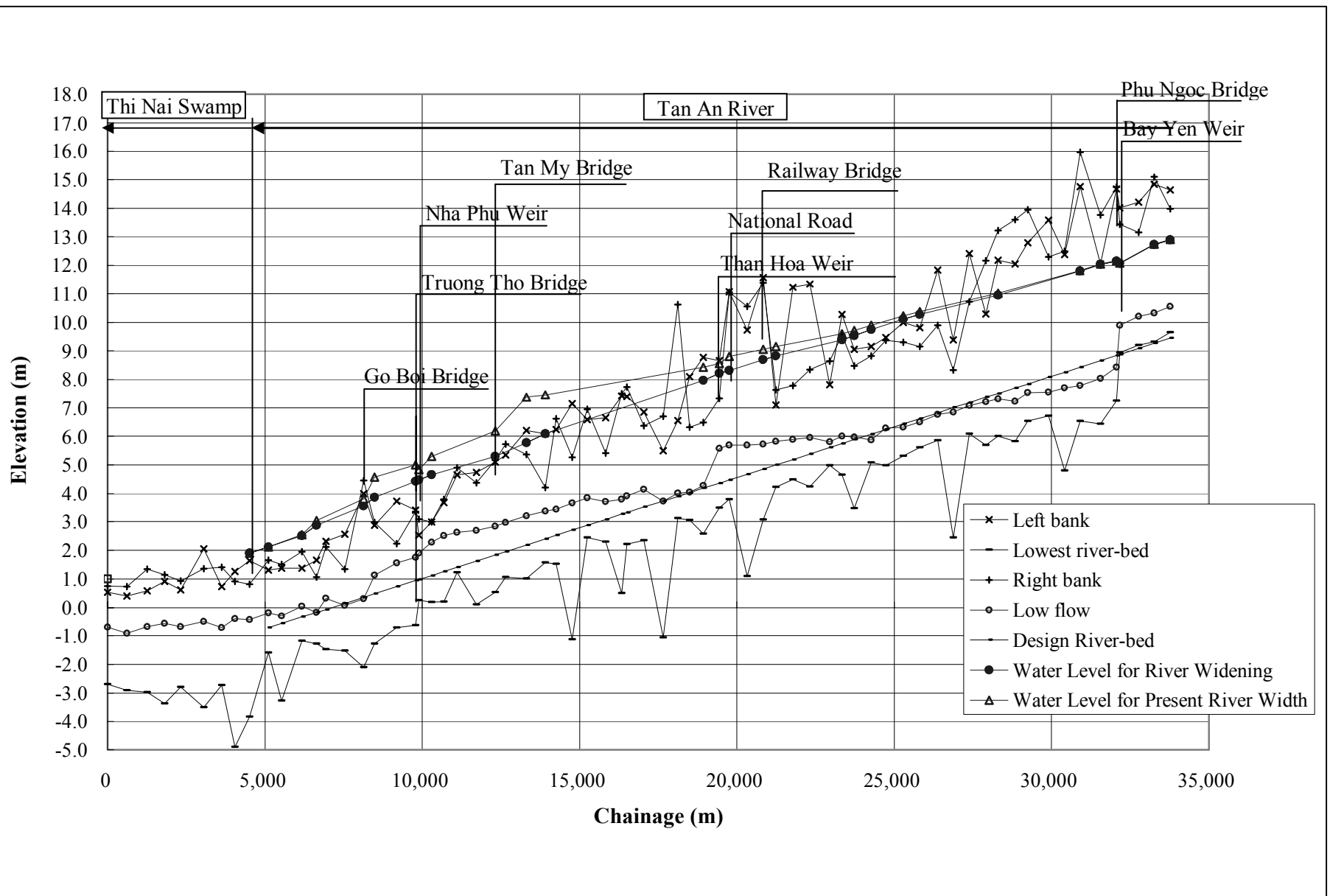
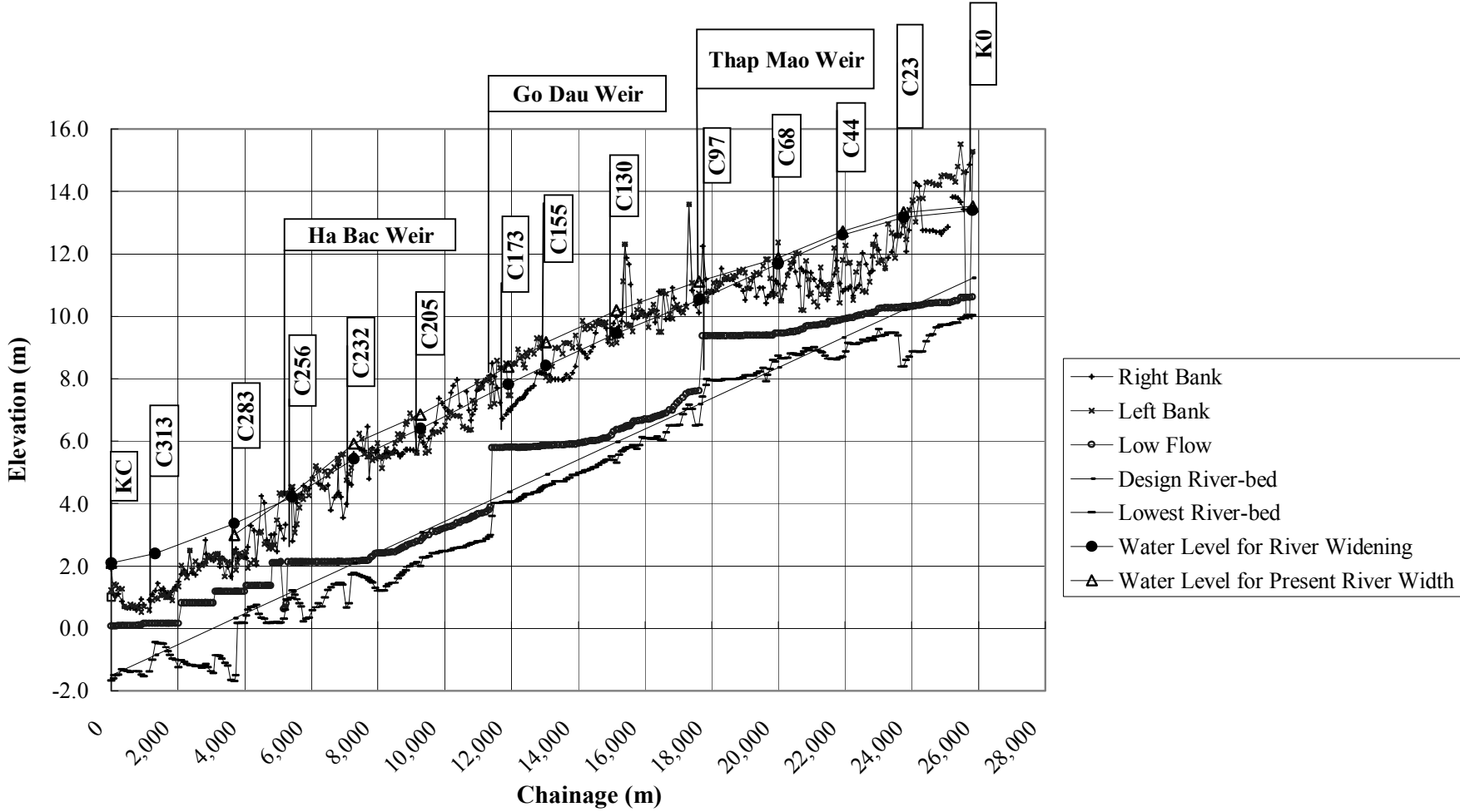

Figure 7.6
Design Flood Hydrograph of 5% Probable
Late Flood







- +— Right Bank
- *— Left Bank
- Low Flow
- — Design River-bed
- — Lowest River-bed
- Water Level for River Widening
- △— Water Level for Present River Width

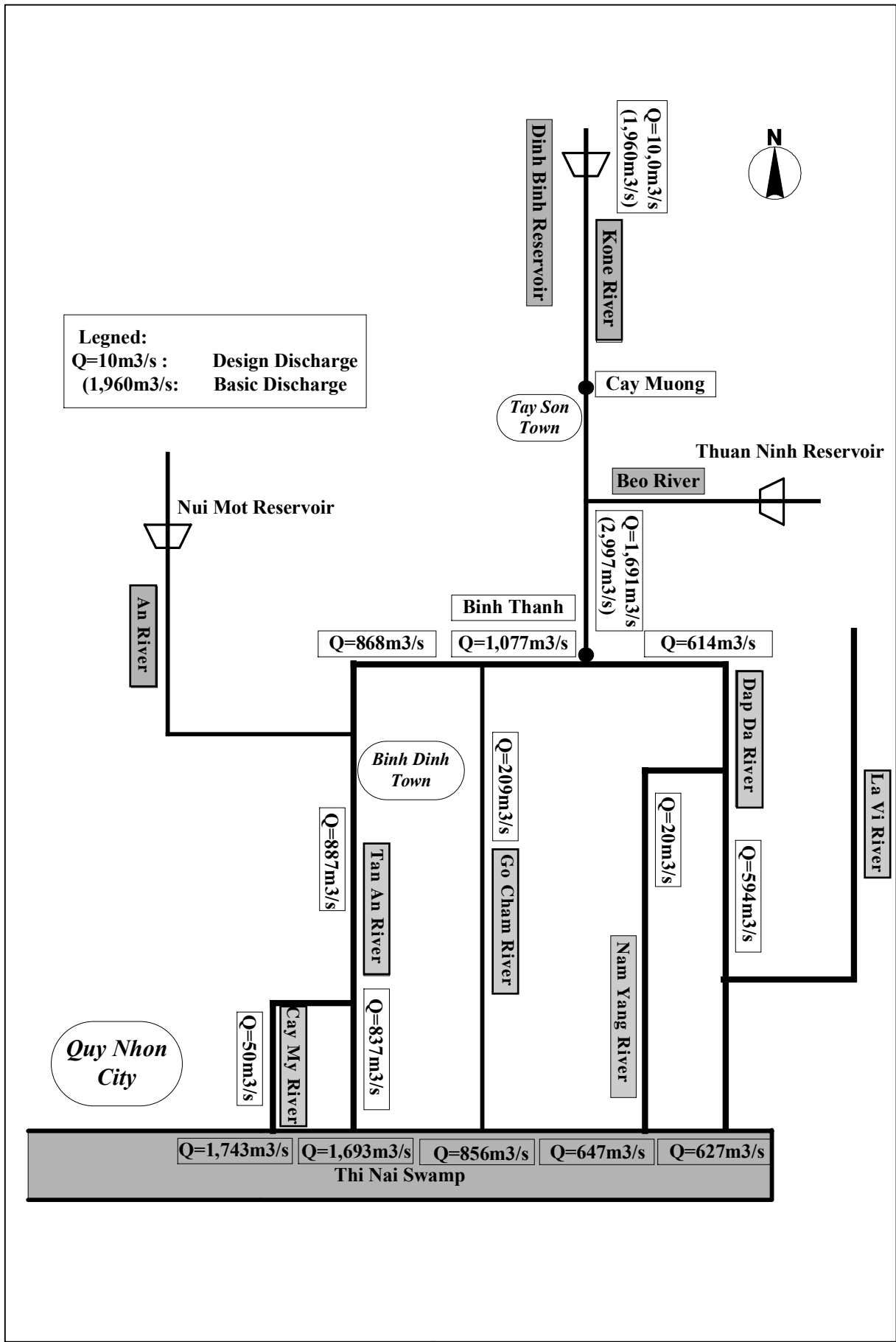

The Study on Nationwide Water Resources
 Development and Management
 in the Socialist Republic of Vietnam

JAPAN INTERNATIONAL COOPERATION AGENCY

Figure 7.10
Design Discharge Distribution of Kone
River Delta

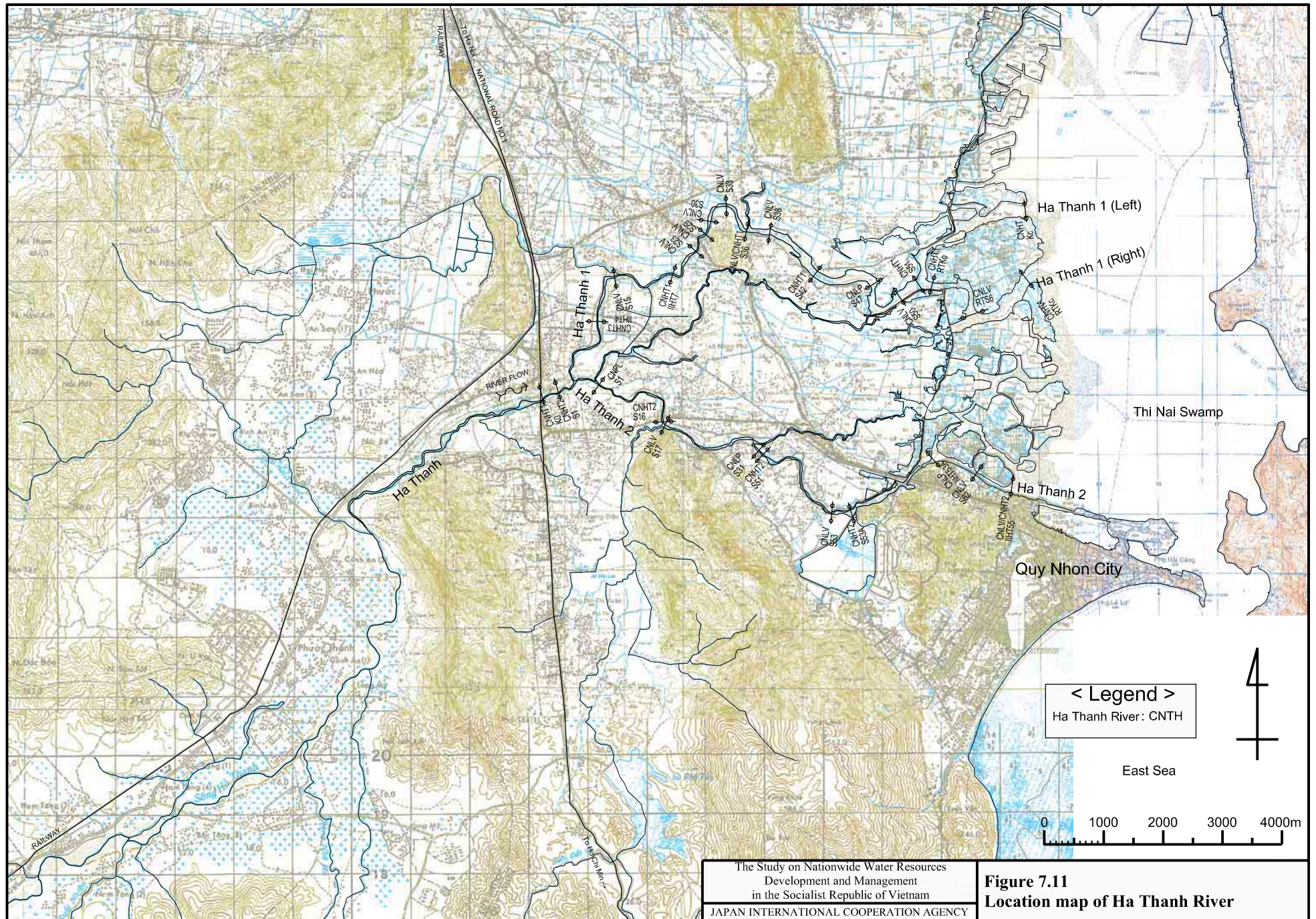

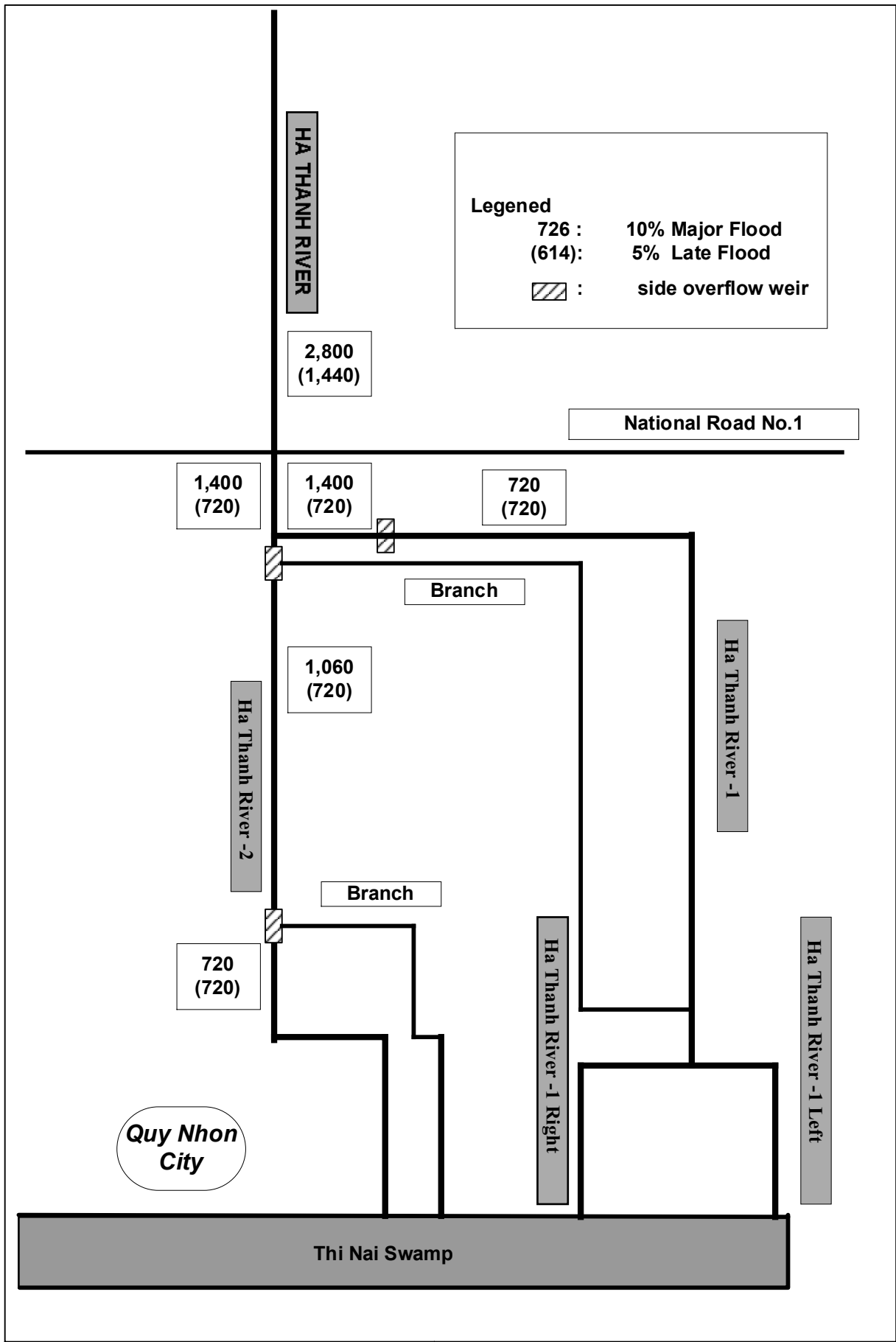

Figure 7.12
Design Discharge Distribution of Ha Thanh River with Side Overflow Weir

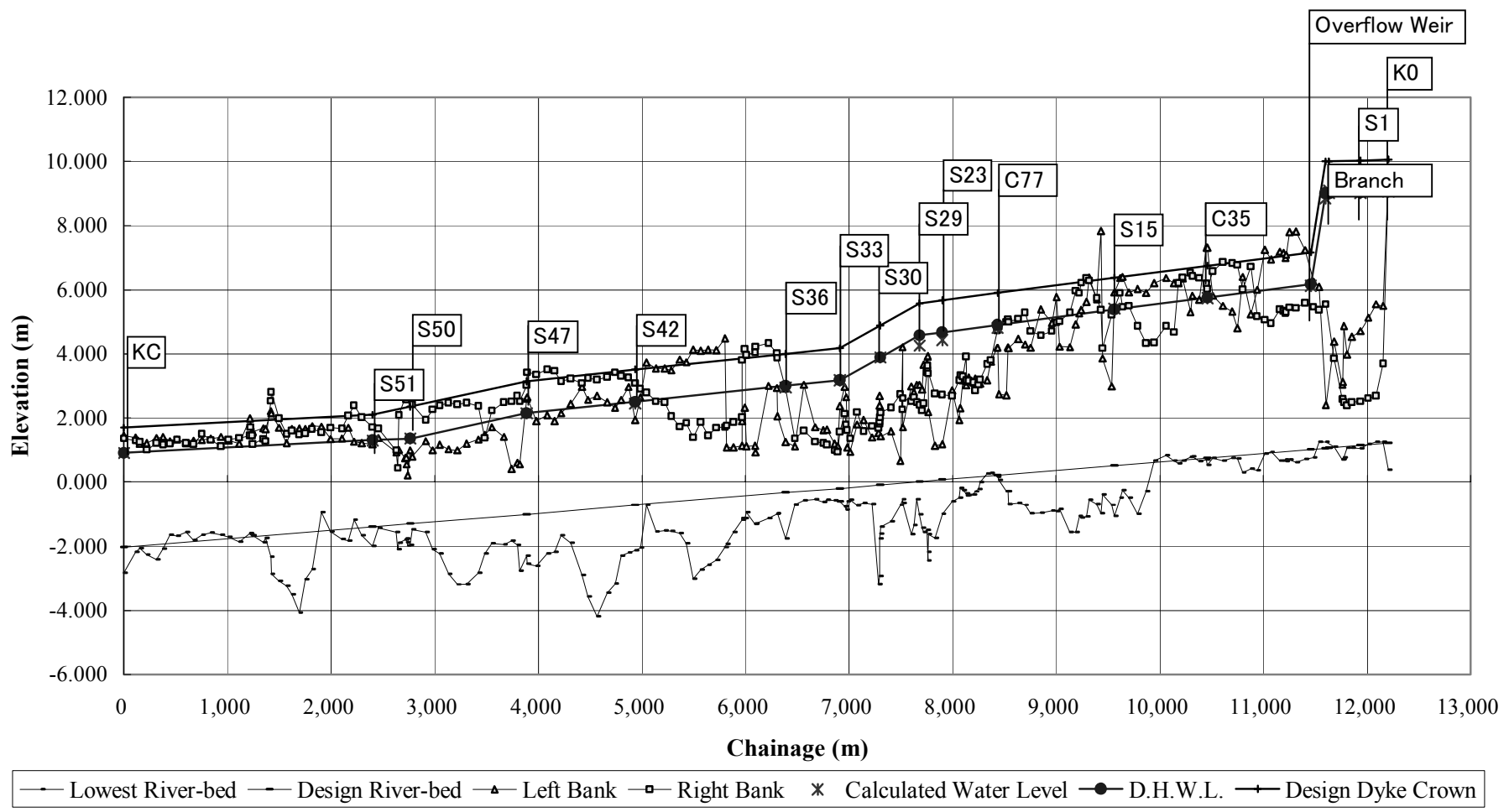
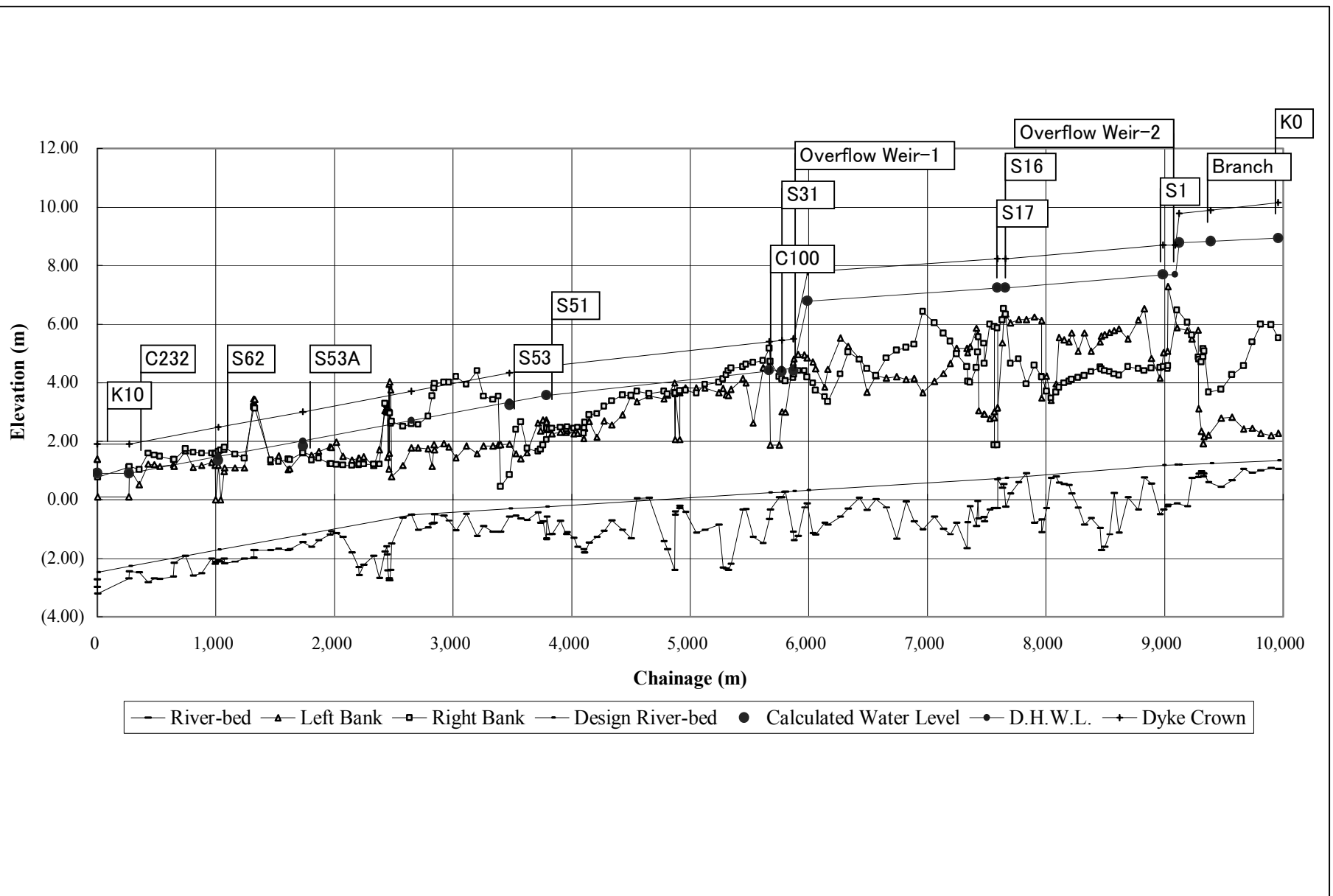

Figure 7.14
Design Longitudinal Profile of Ha Thanh River-2
with Side Overflow Weir for 10% Major Flood



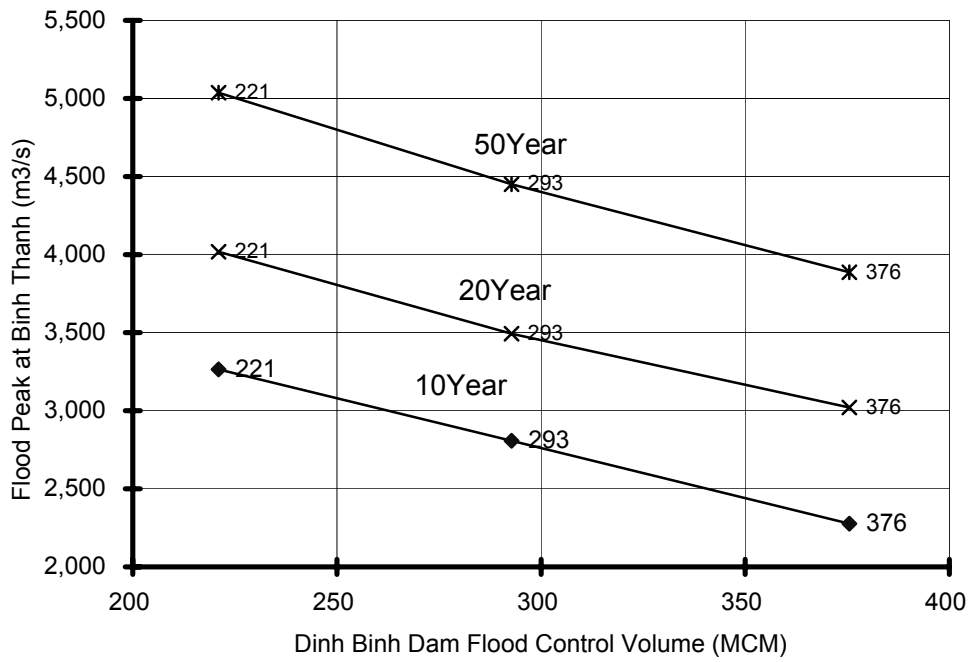

Figure 8.1 Relationship Between Dinh Binh Dam Flood Control Volume and Probable Major Flood Peak Discharge at Binh Thanh

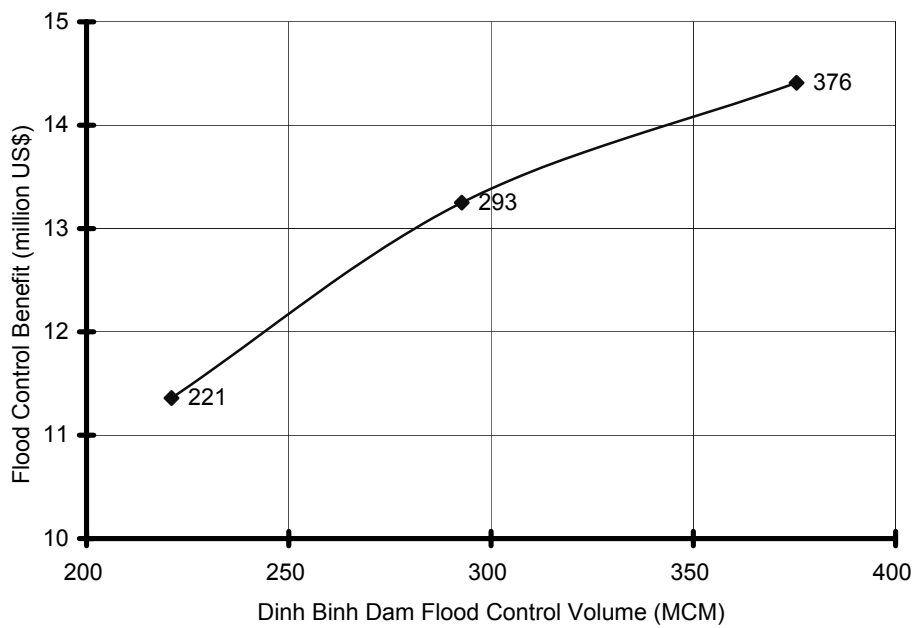
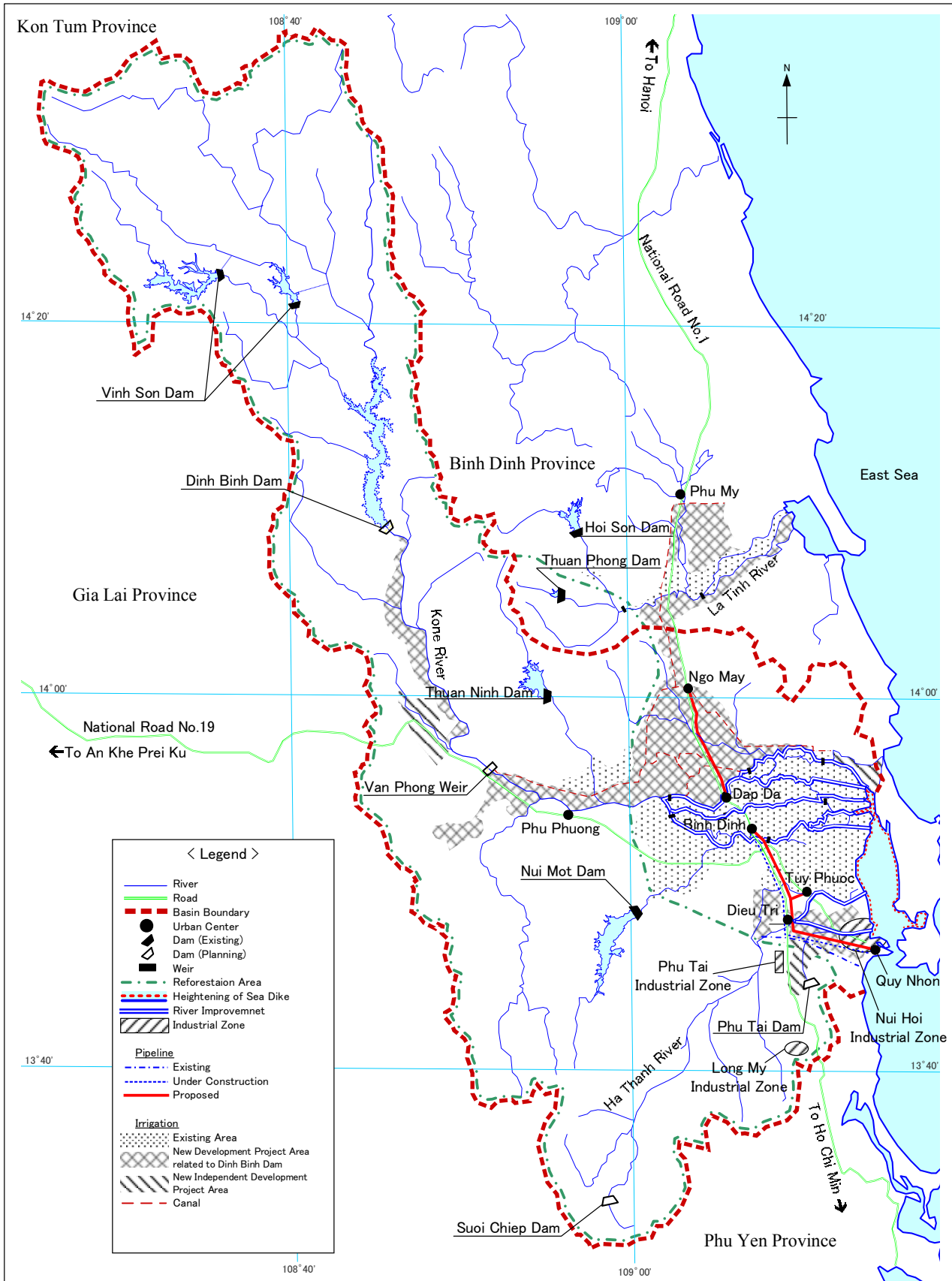

Figure 8.2 Relationship Between Dinh Binh Dam Flood Control Volume and Expected Flood Damage to be Mitigated



The Study on Nationwide Water Resources
Development and Management
in the Socialist Republic of Vietnam
JAPAN INTERNATIONAL COOPERATION AGENCY

Figure 8.3
Location Map of Integrated River Basin
Management Plan