

Figure S3.6 Probable 1% Hydrograph Main Flood at Dinh Binh, Cay Muong and Binh Thanh

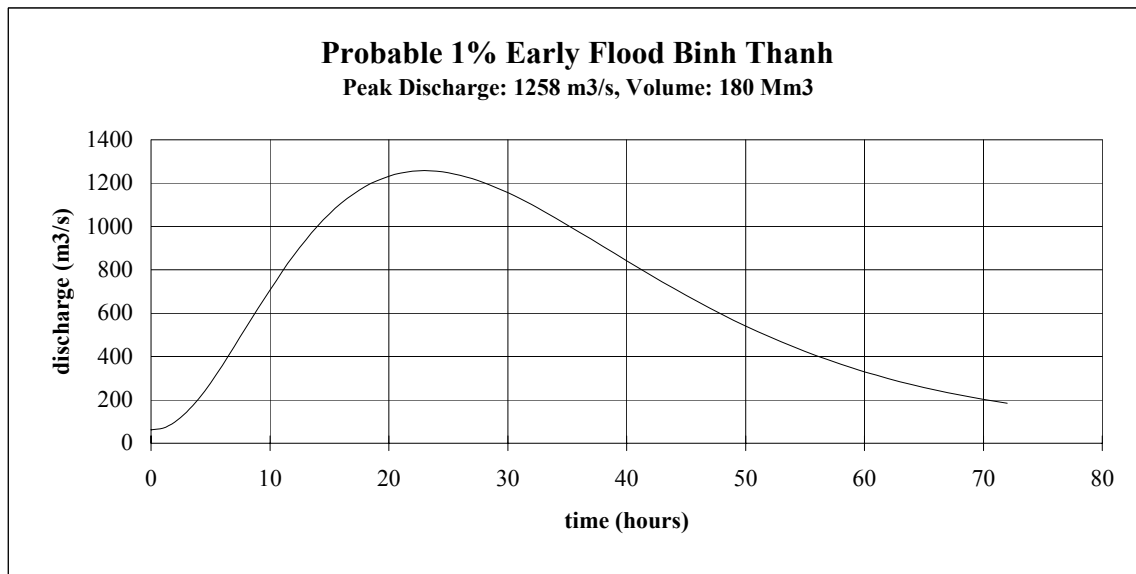
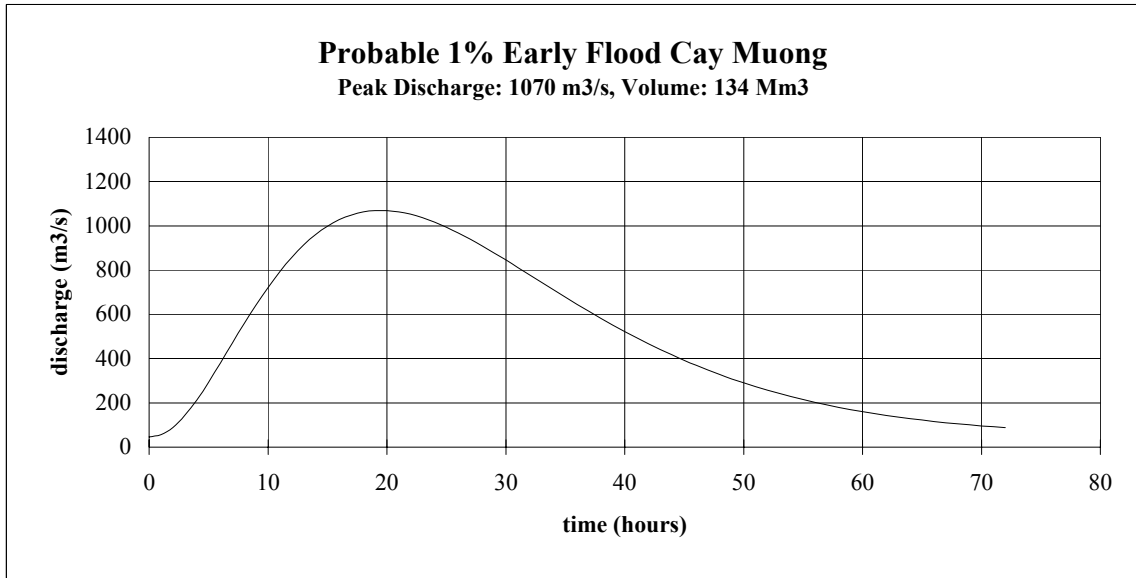
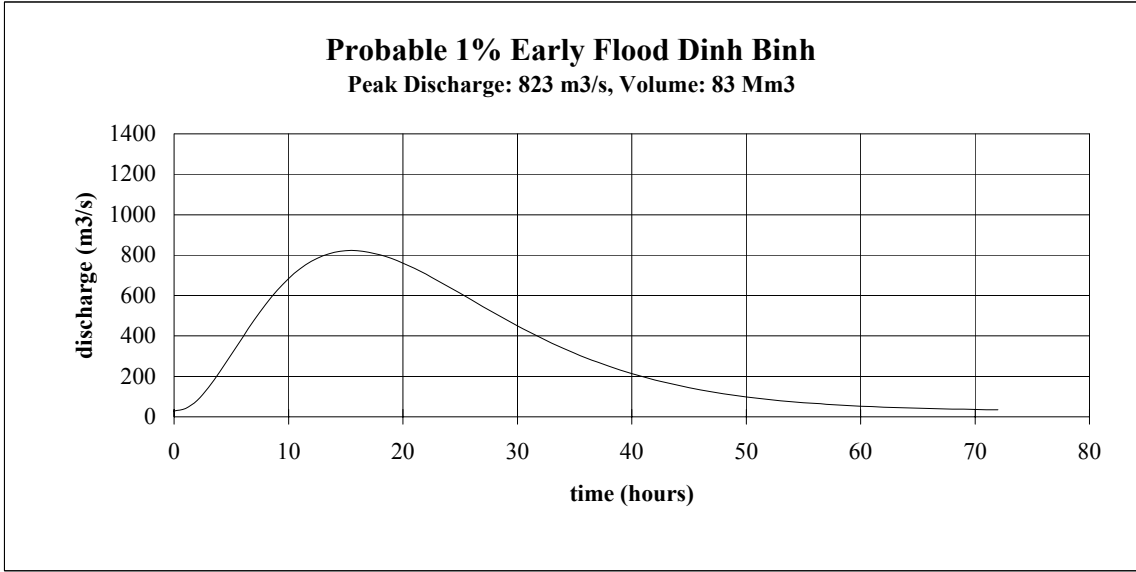

Figure S3.7 Probable 1% Hydrograph Early Flood at Dinh Binh, Cay Muong and Binh Thanh

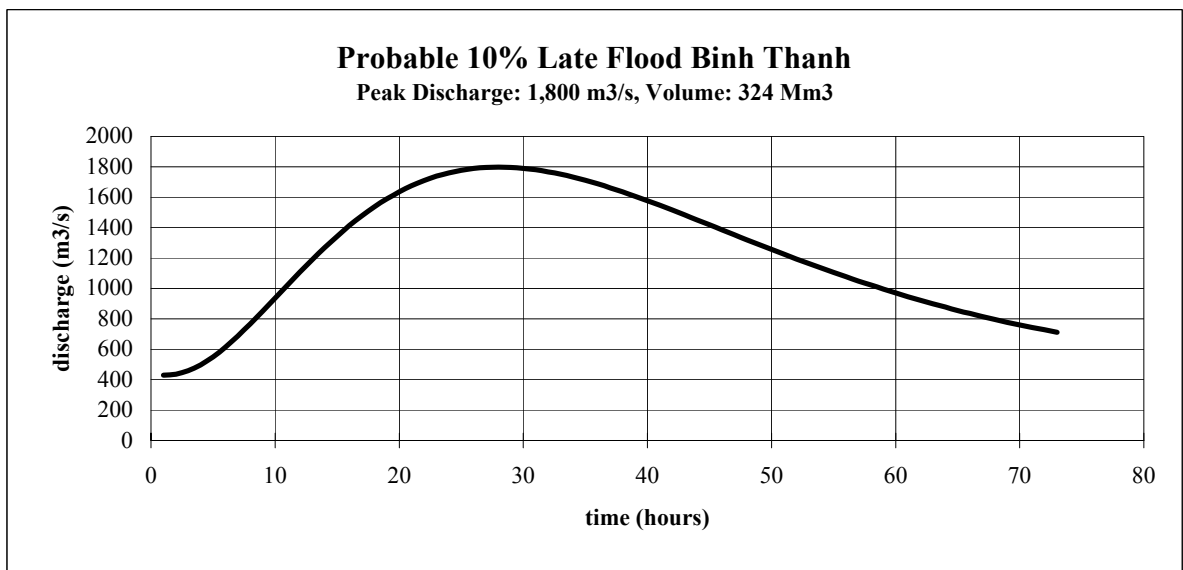
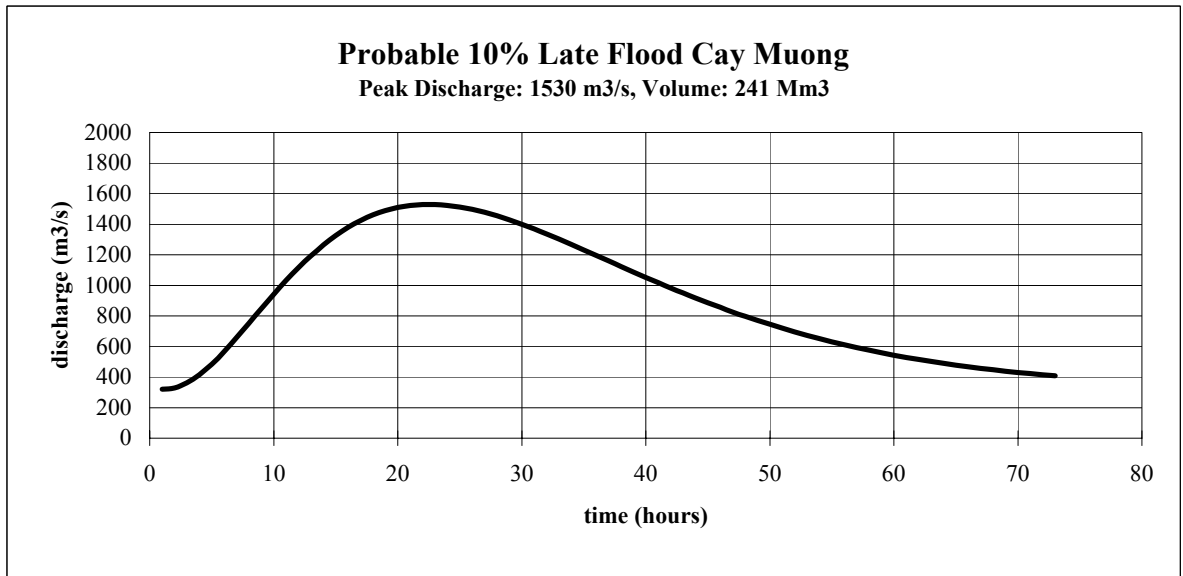
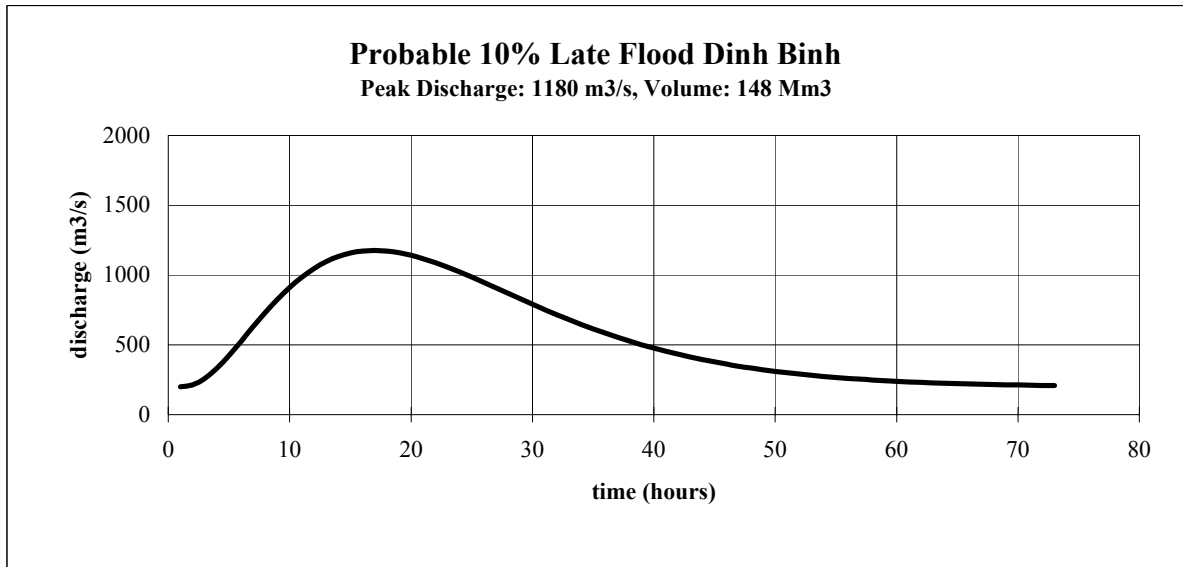
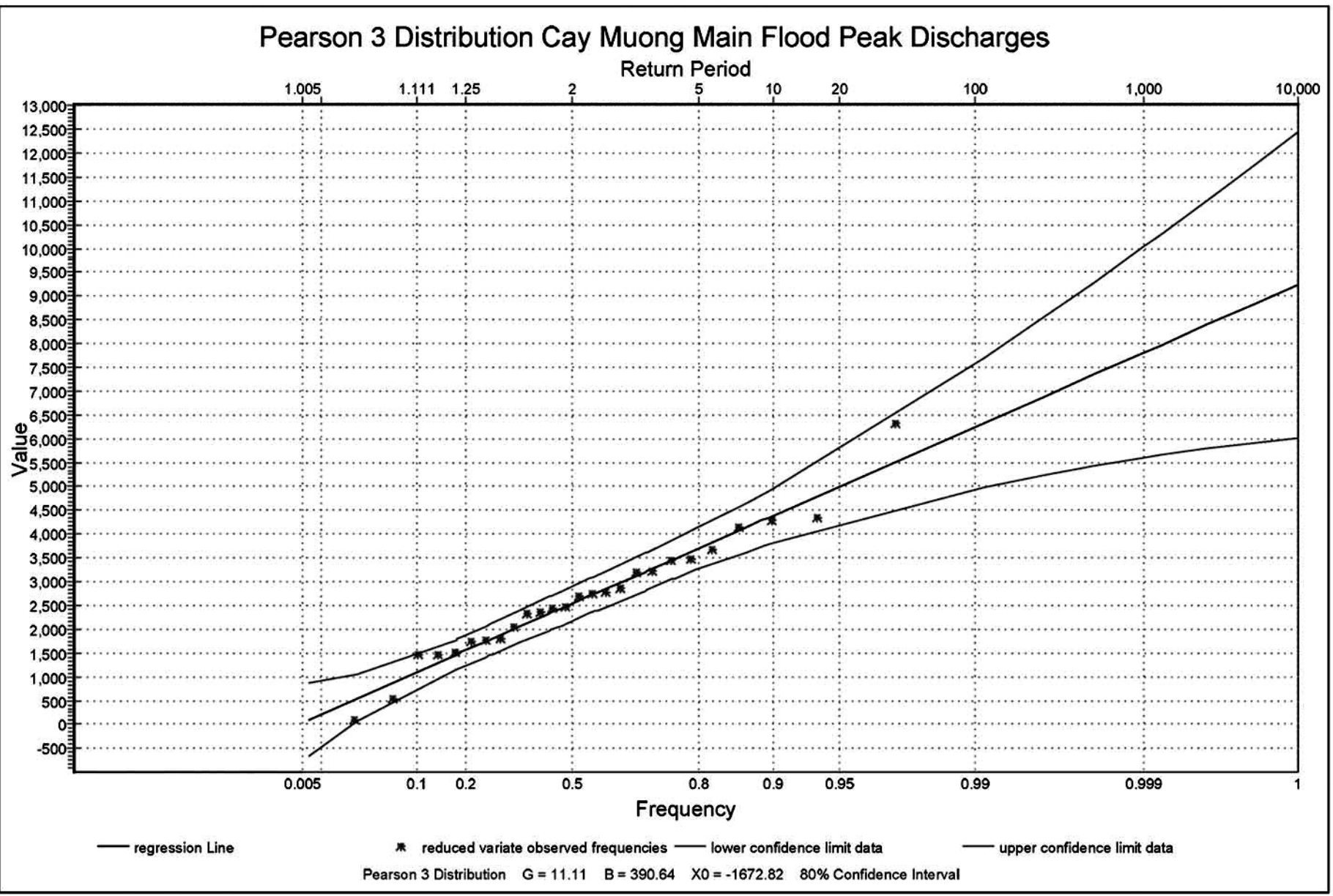
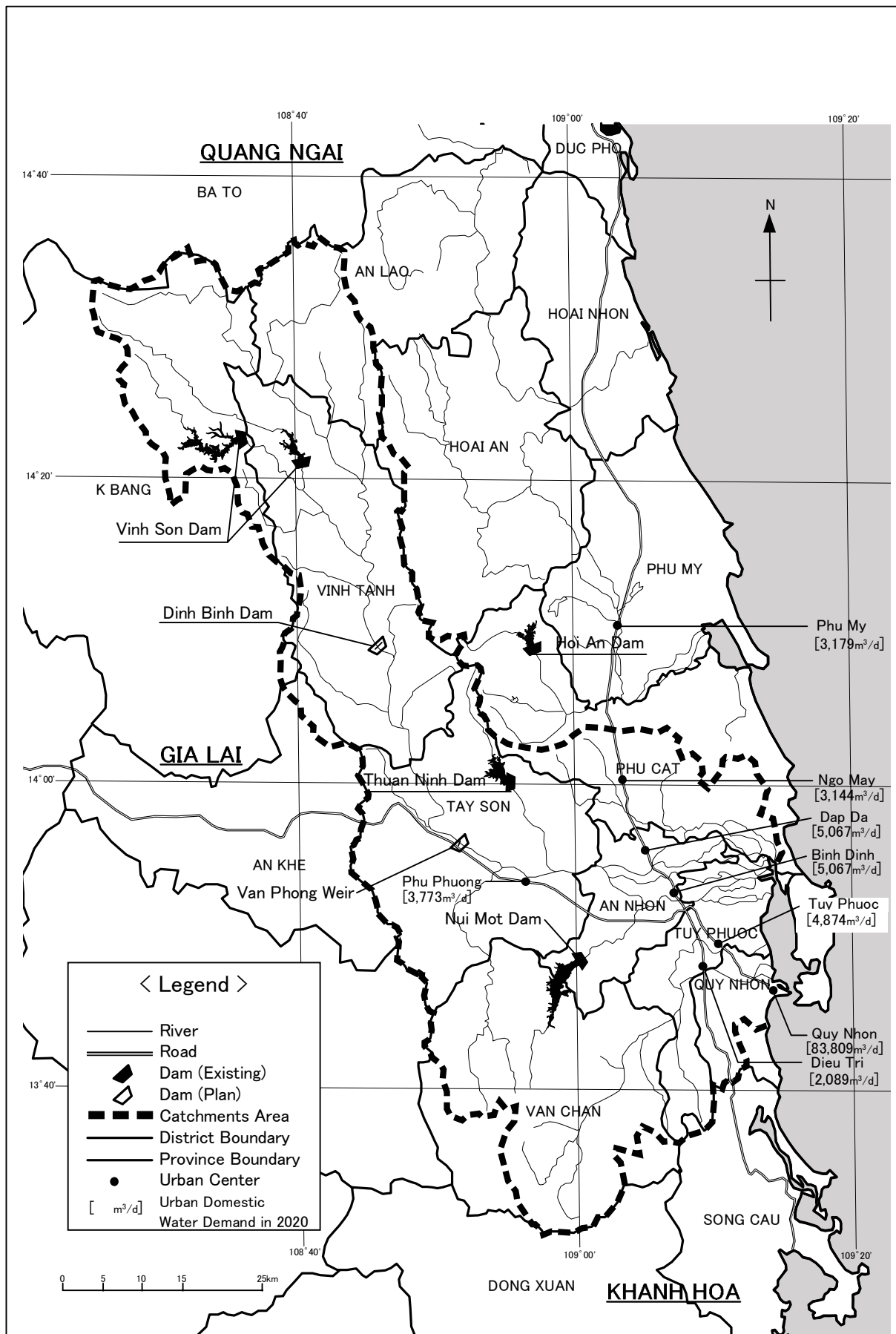

Figure S3.8 Probable 10% Hydrograph Late Flood at Dinh Binh, Cay Muong and Binh Thanh





The Study on Nationwide Water Resources
Development and Management
in the Socialist Republic of Vietnam

JAPAN INTERNATIONAL COOPERATION AGENCY

Figure S3.10
**Urban Domestic Water Demand in Each
Urban Center in 2020**

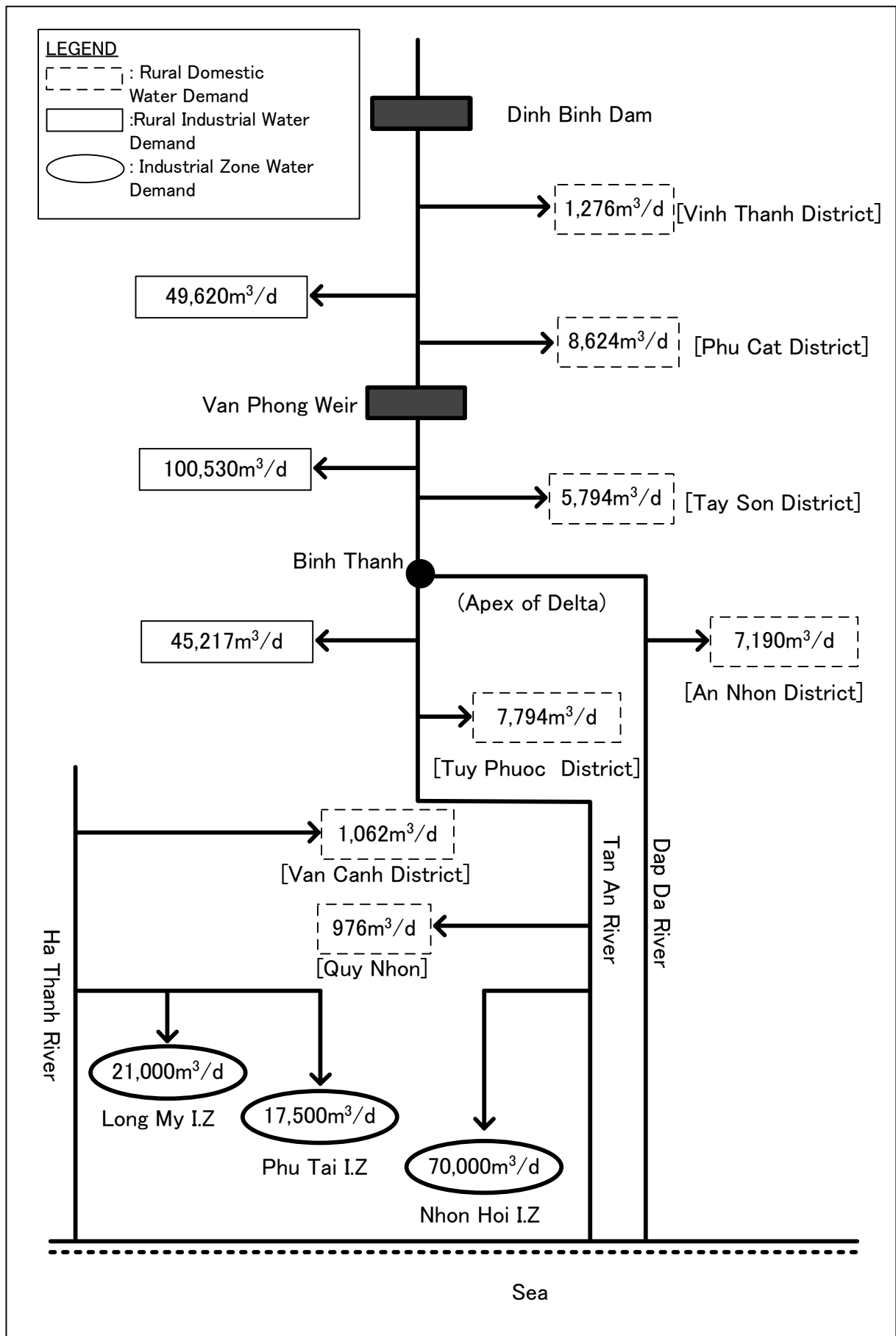

The Study on Nationwide Water Resources Development and Management in the Socialist Republic of Vietnam
 JAPAN INTERNATIONAL COOPERATION AGENCY

Figure S3.11
 Schematic Presentation of Rural Domestic and Industrial Water Demand in 2020

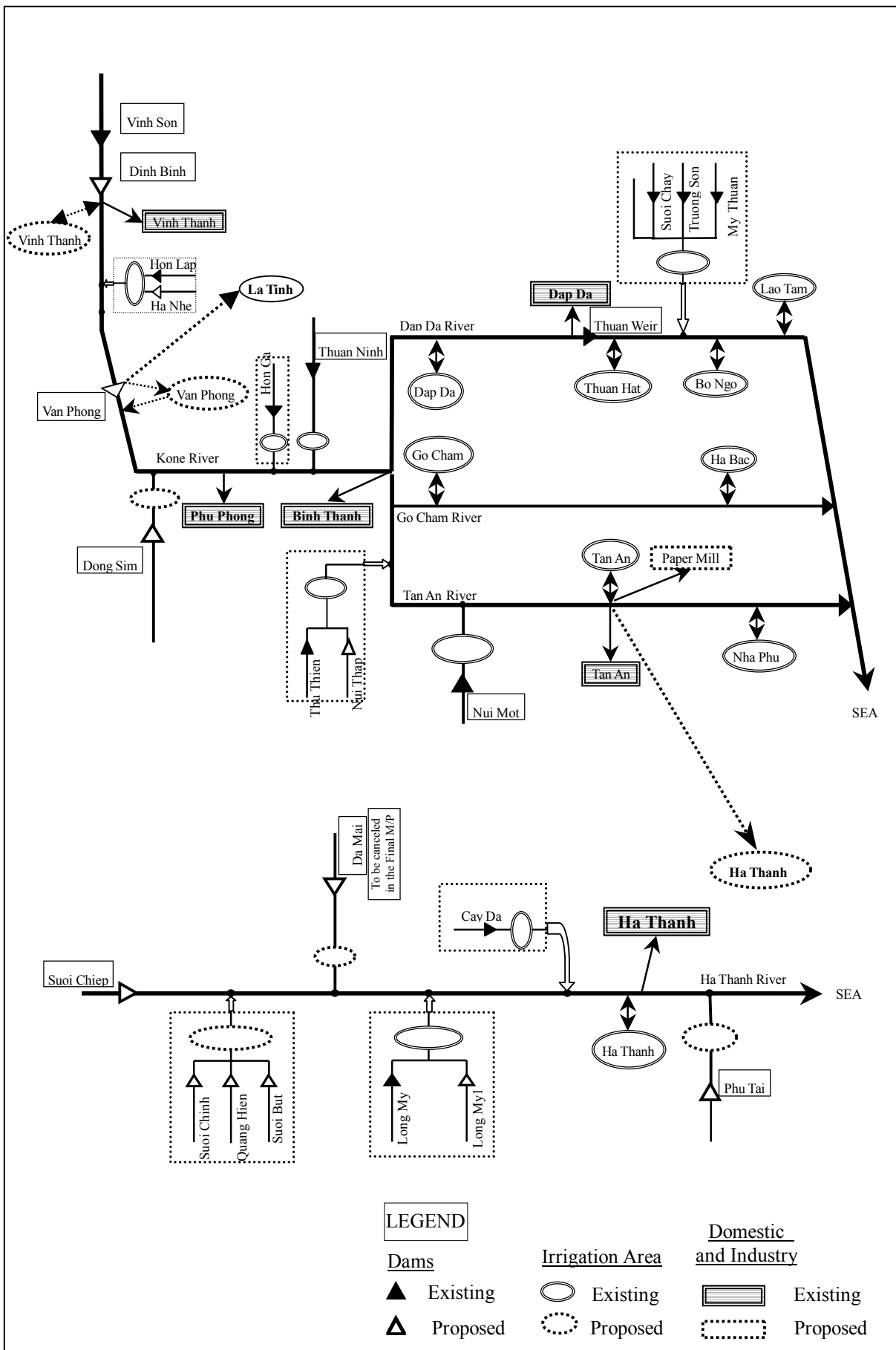

The Study on Nationwide Water Resources Development and Management in the Socialist Republic of Vietnam

JAPAN INTERNATIONAL COOPERATION AGENCY

Figure S3.12

Schematic Model of Water Balance Analysis

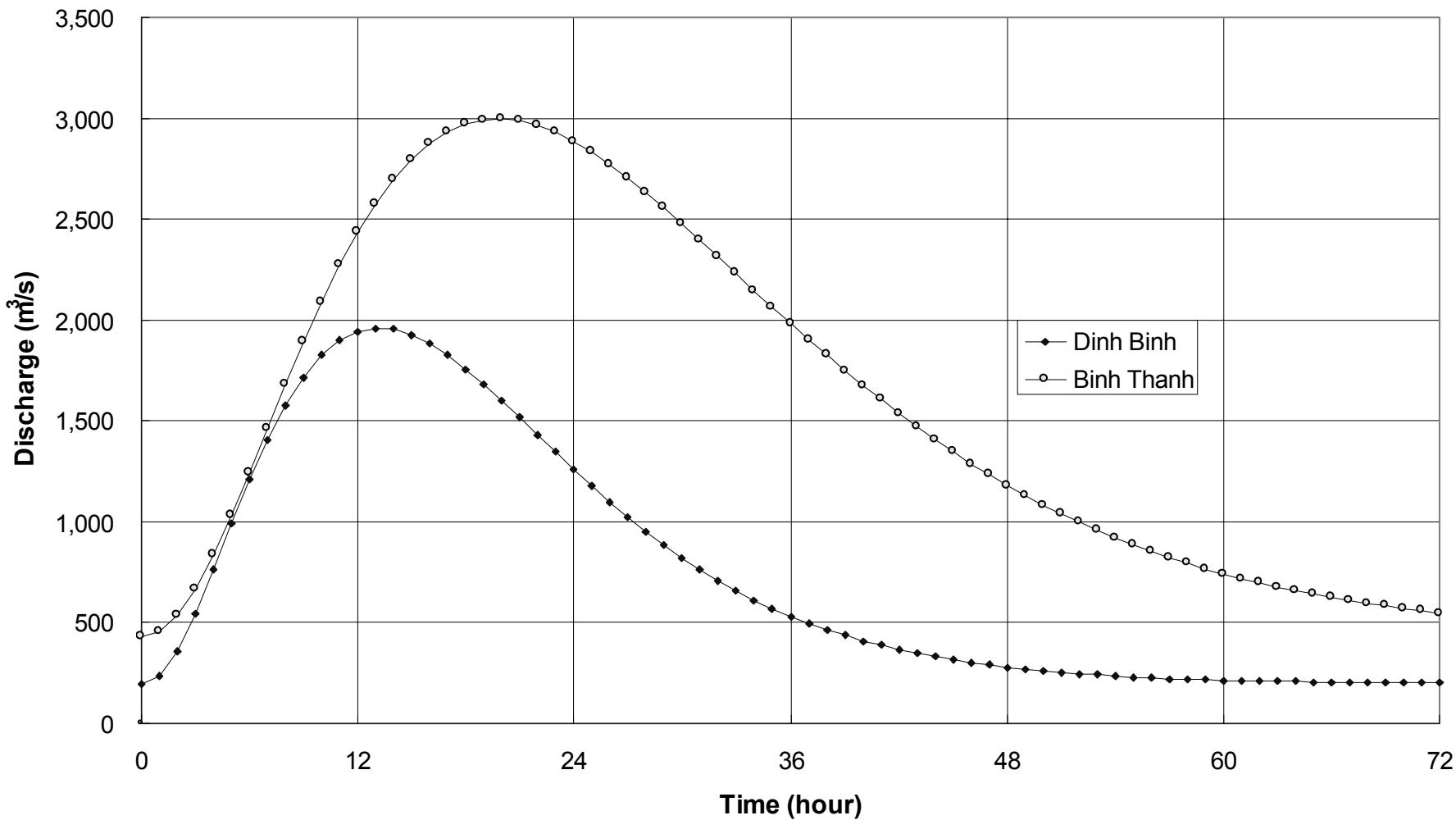

The Study on Nationwide Water Resources Development and Management in the Socialist Republic of Vietnam
JAPAN INTERNATIONAL COOPERATION AGENCY

Figure S3.13
Design Flood Hydrograph of 5% Probable Late Flood

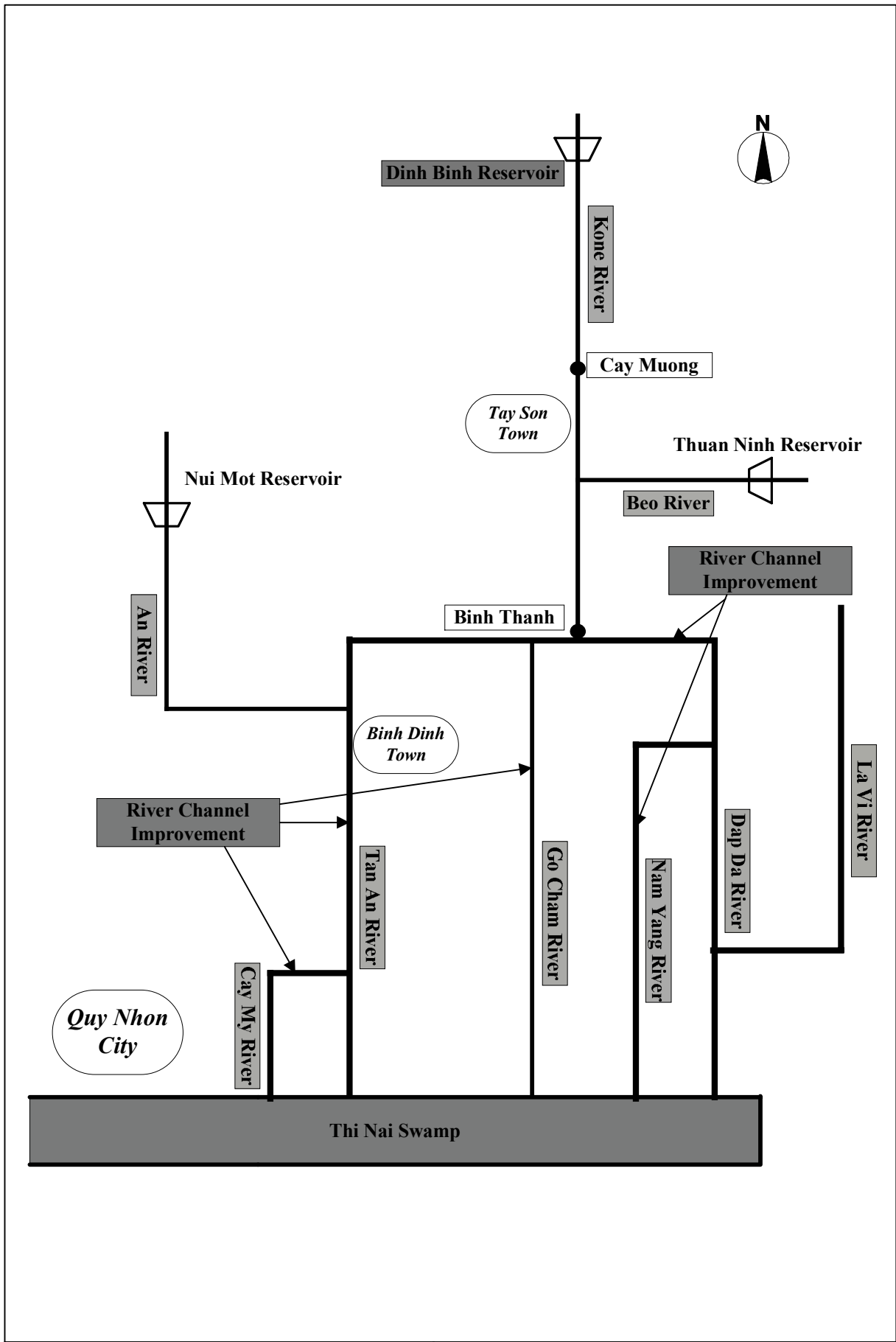

The Study on Nationwide Water Resources
 Development and Management
 in the Socialist Republic of Vietnam
 JAPAN INTERNATIONAL COOPERATION AGENCY

Figure S3.14
Distribution of Flood Control Facilities of
Kone River

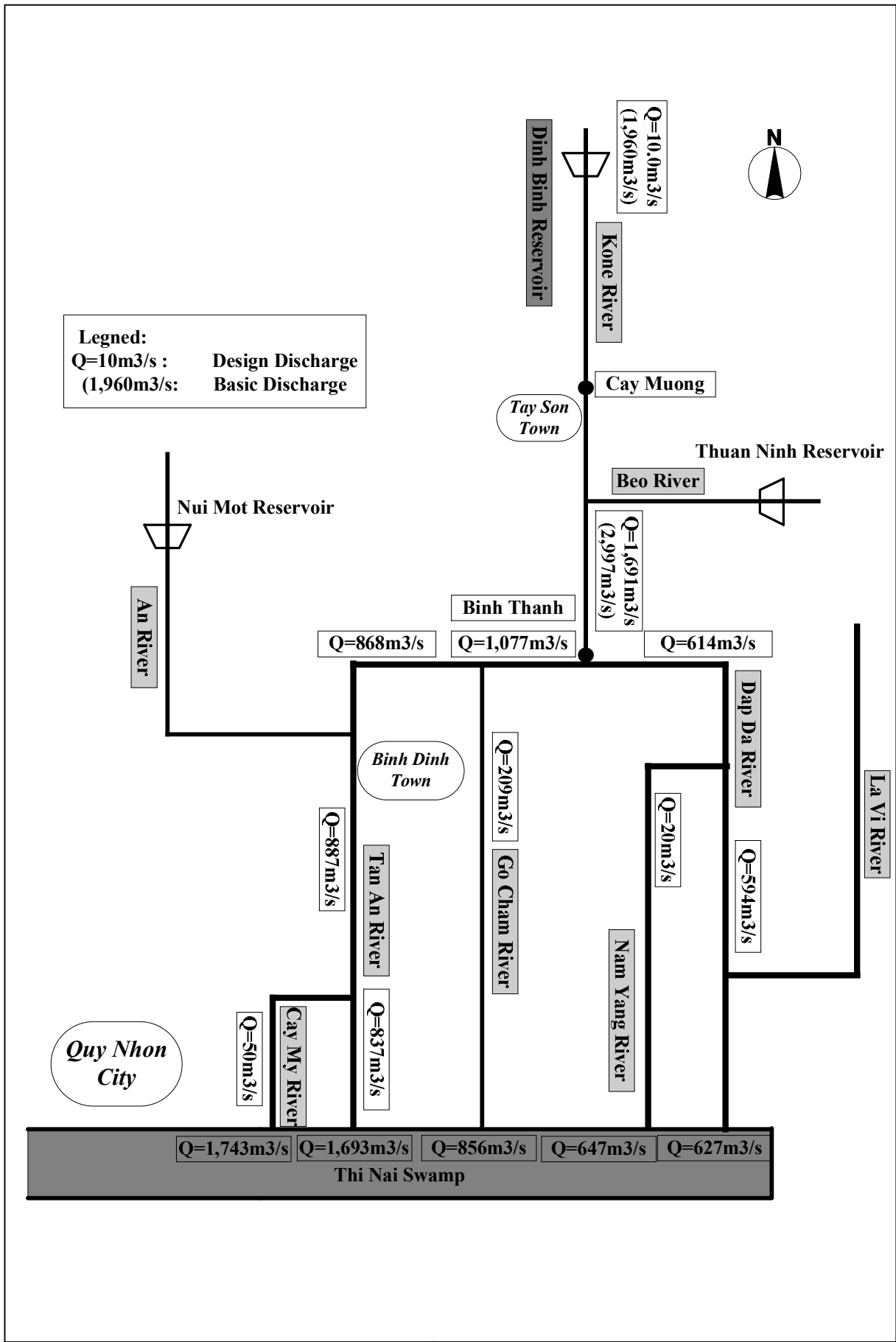

Figure S3.15
Design Discharge Distribution of Kone River Delta

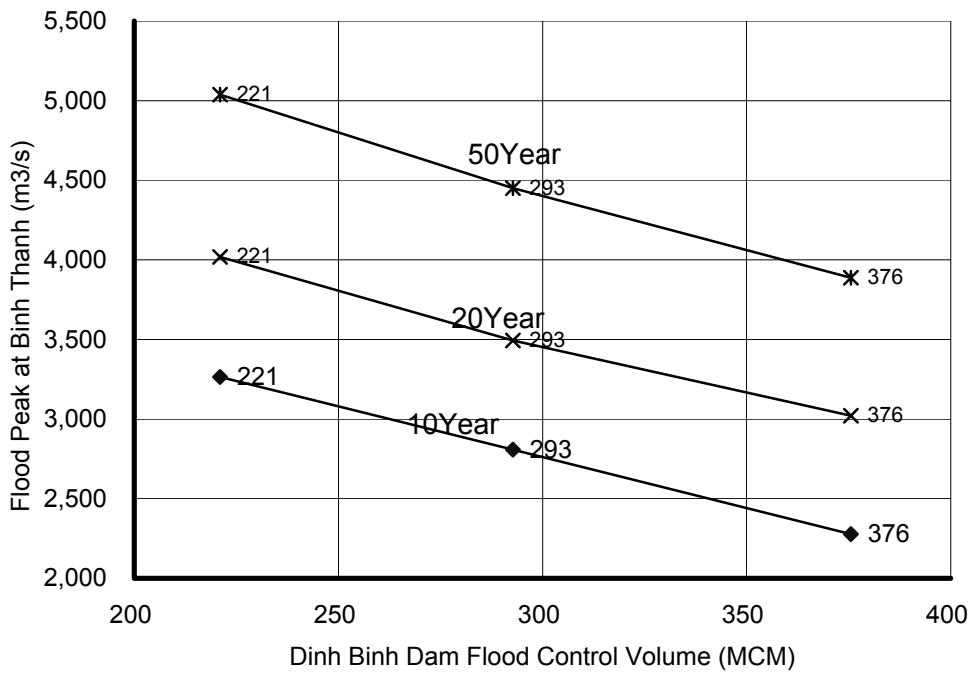

Figure S3.16 Relationship Between Dinh Binh Dam Flood Control Volume and Probable Major Flood Peak Discharge at Binh Thanh

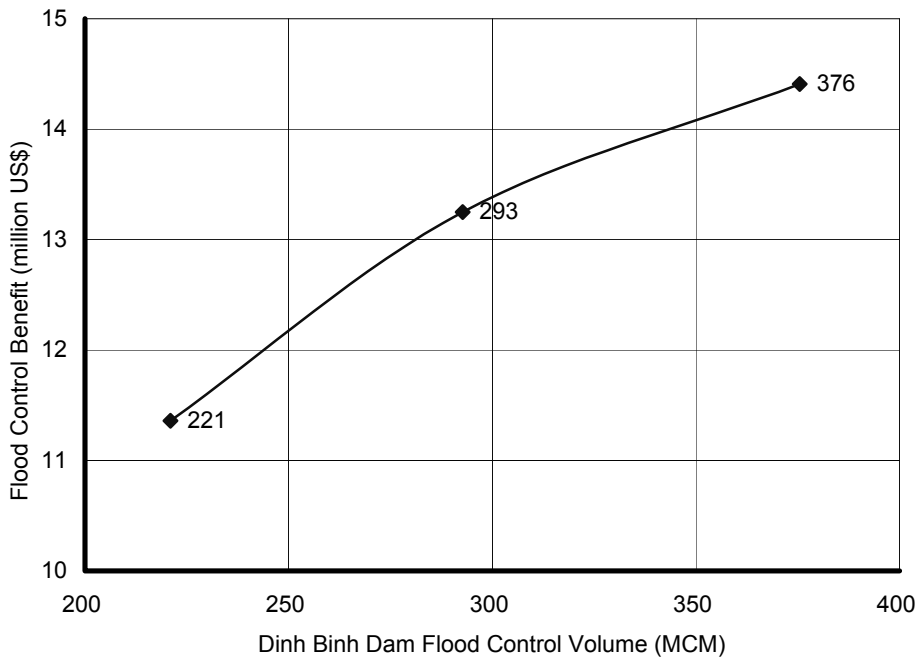

Figure S3.17 Relationship Between Dinh Binh Dam Flood Control Volume and Expected Flood Damage to be Mitigated

