

Planta de Interseção

Avenida Independência x Avenida Júlio César

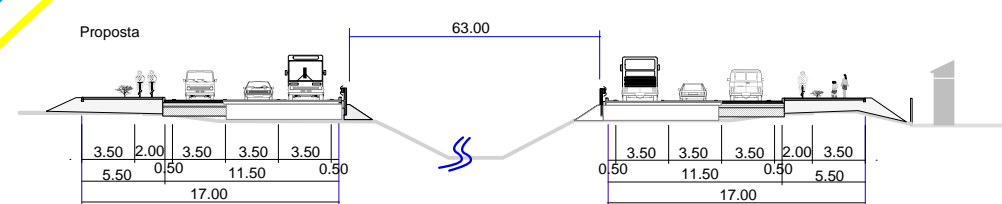
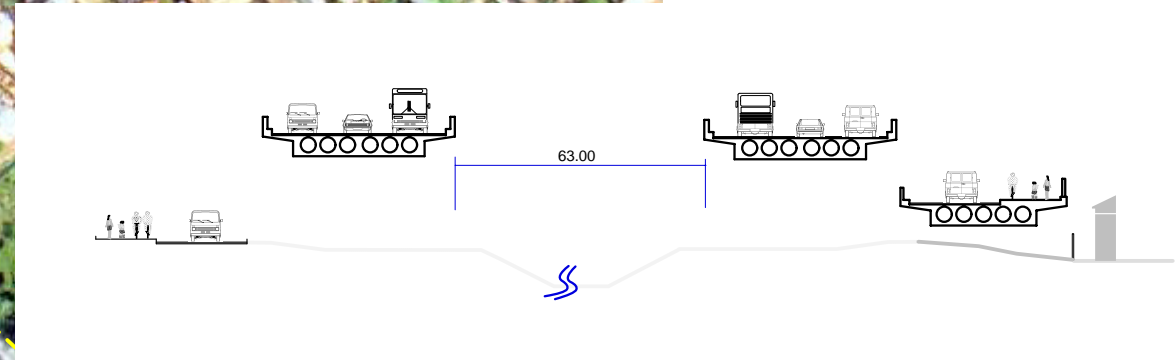
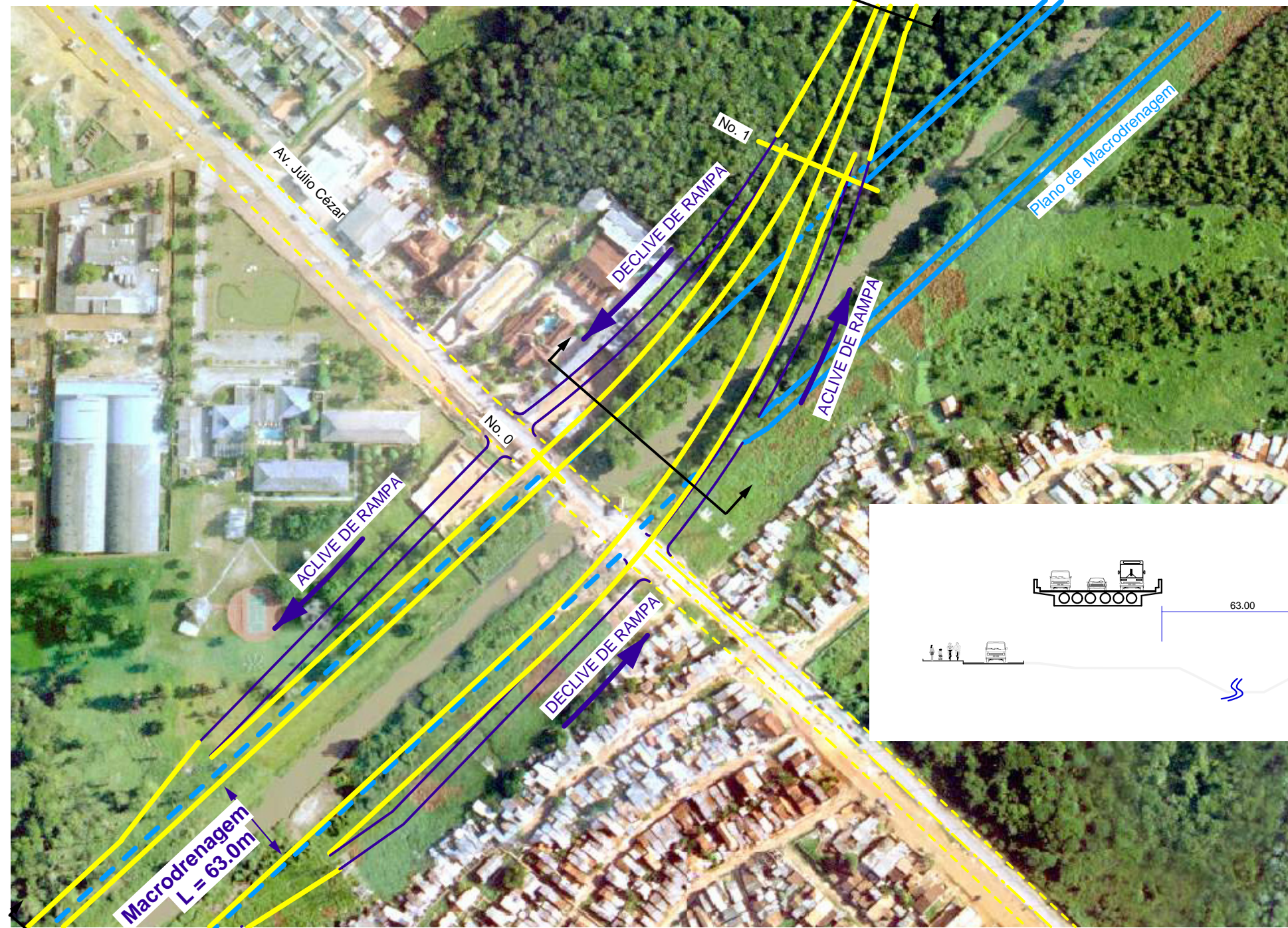
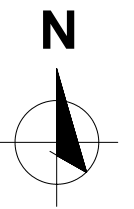
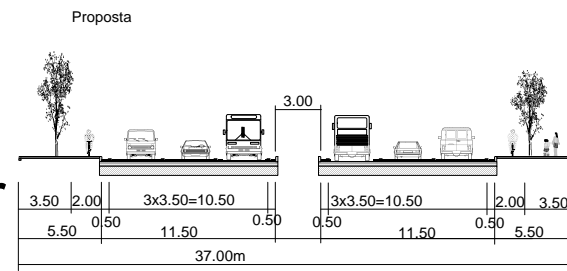

| | | | | |
|---|--|---|--|---------------|
| Planta de Interseção Avenida Independência x Avenida Júlio César | GOVERNO DO ESTADO DO PARÁ SECRETARIA ESPECIAL DE ESTADO DE INTEGRAÇÃO REGIONAL (SEIR) | AGÊNCIA DE COOPERAÇÃO INTERNACIONAL DO JAPÃO (JICA) | ESTUDO DE VIABILIDADE ECONÔMICA DE PROJETOS PARA O MELHORAMENTO DO SISTEMA DE TRANSPORTE NA REGIÃO METROPOLITANA DE BELÉM | |
| | | | DATA | DESENHO No. |
| | | ESCALA | S = 1 : 3,000 | PÁGINA No. 34 |

Planta de Interseção

Avenida Independência x Rua Yamada

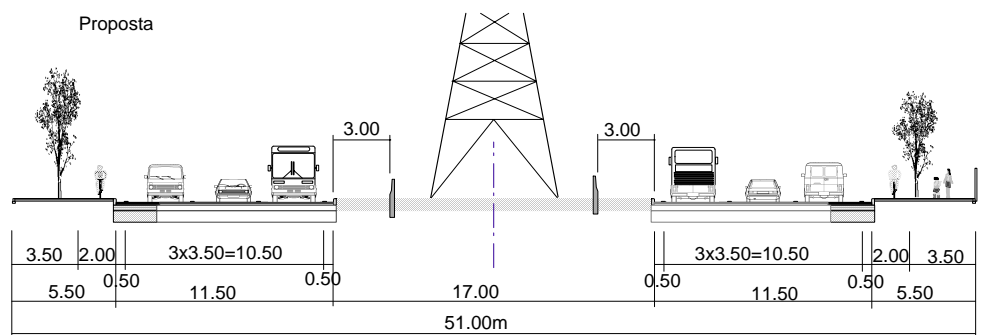
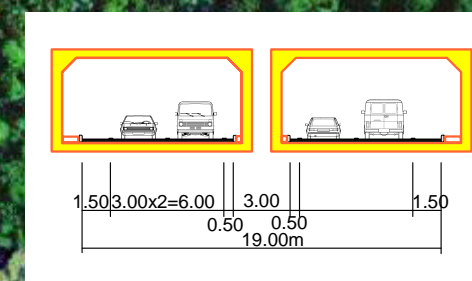
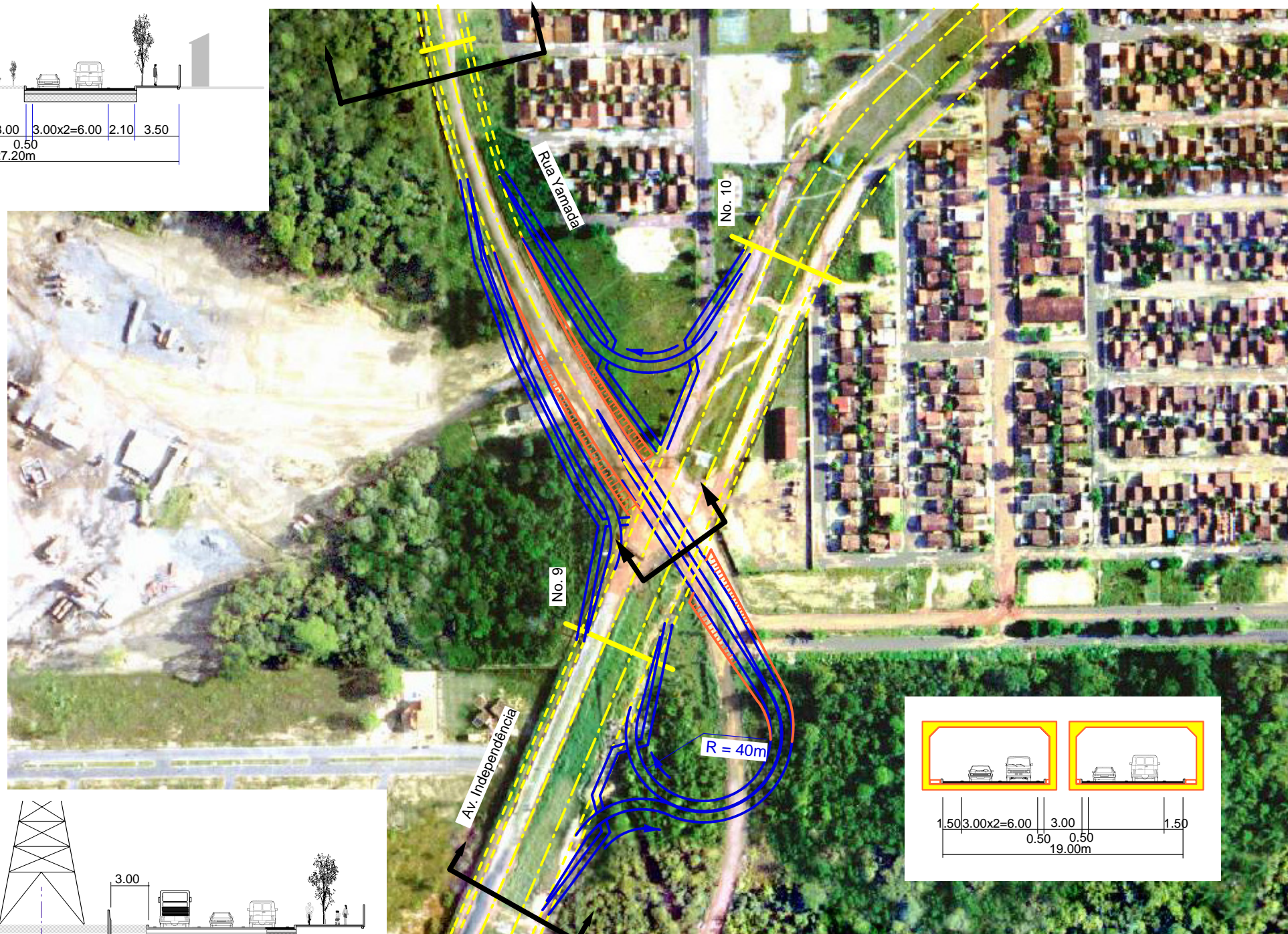
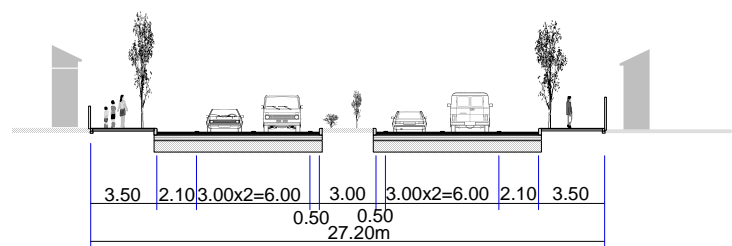
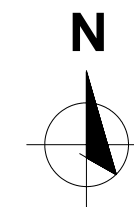

Planta de Interseção
Avenida Independência x Rua Yamada

GOVERNO DO ESTADO DO PARÁ
SECRETARIA ESPECIAL DE ESTADO DE
INTEGRAÇÃO REGIONAL
(SEIR)

AGÊNCIA DE COOPERAÇÃO
INTERNACIONAL DO JAPÃO
(JICA)

ESTUDO DE VIABILIDADE ECONÔMICA DE PROJETOS PARA O MELHORAMENTO
DO SISTEMA DE TRANSPORTE NA REGIÃO METROPOLITANA DE BELÉM

DATA _____
ESCALA S = 1 : 3,000

DESENHO No. _____
PÁGINA No. 35

Planta de Interseção

Rodovia Augusto Montenegro x Avenida Independência

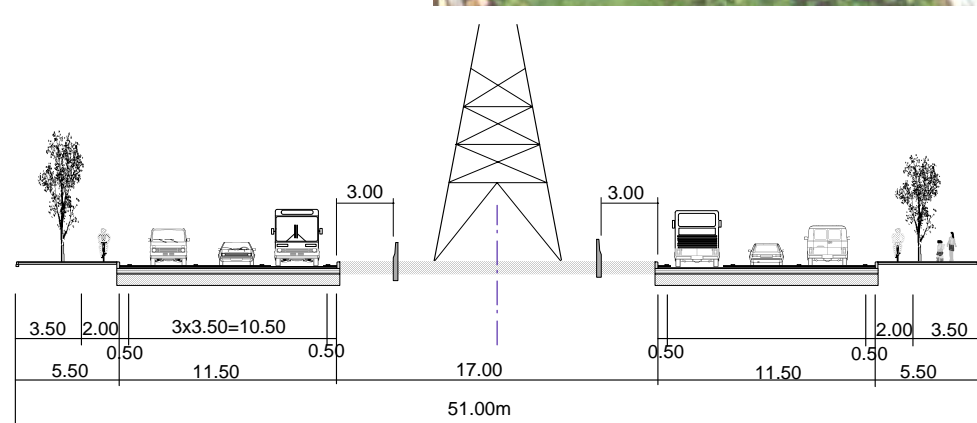
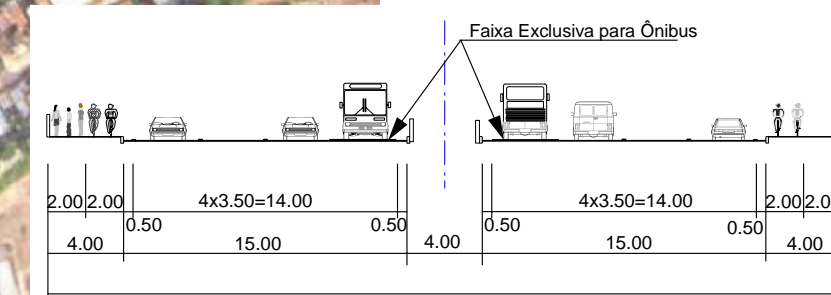
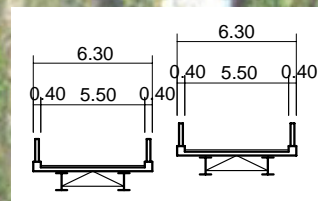
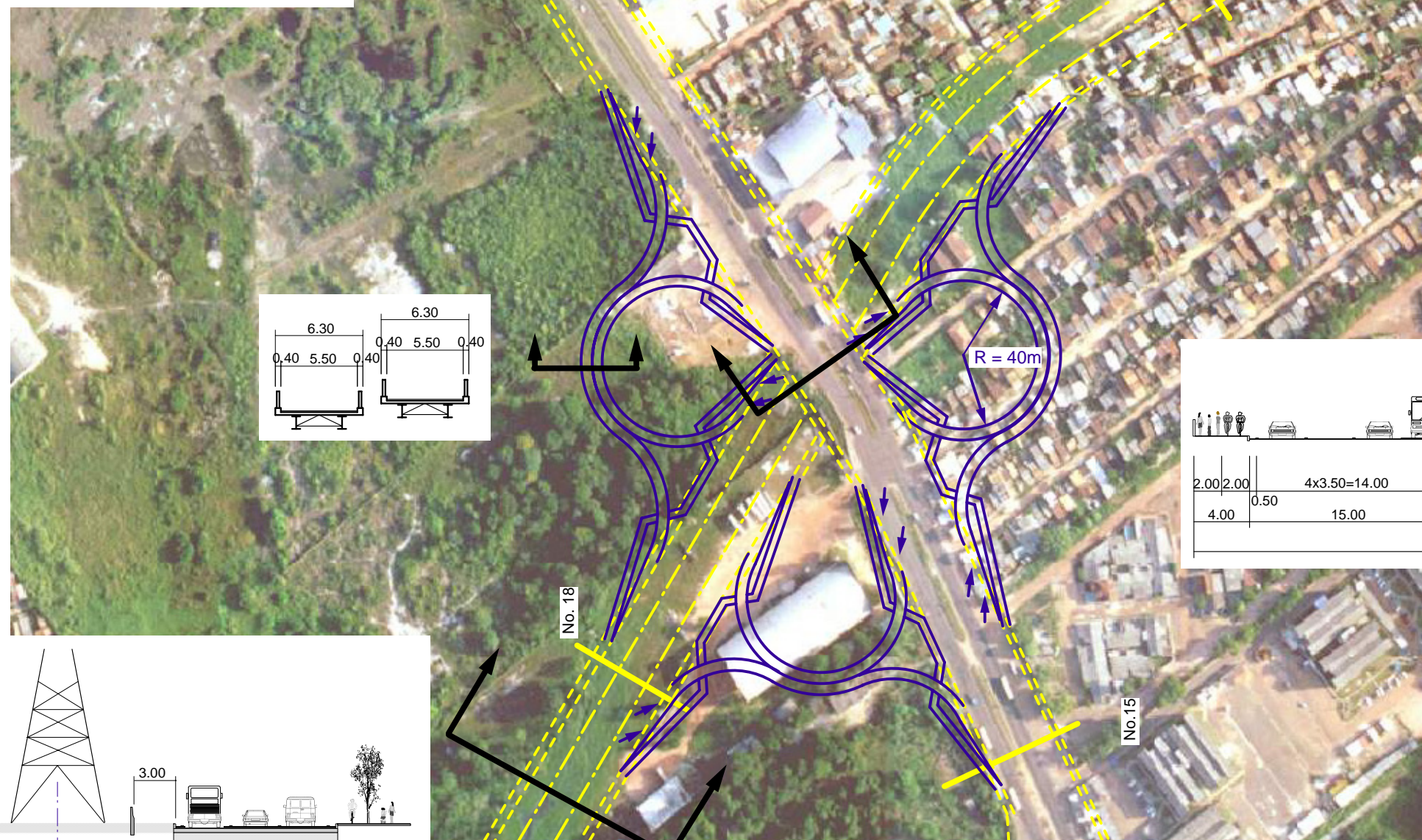
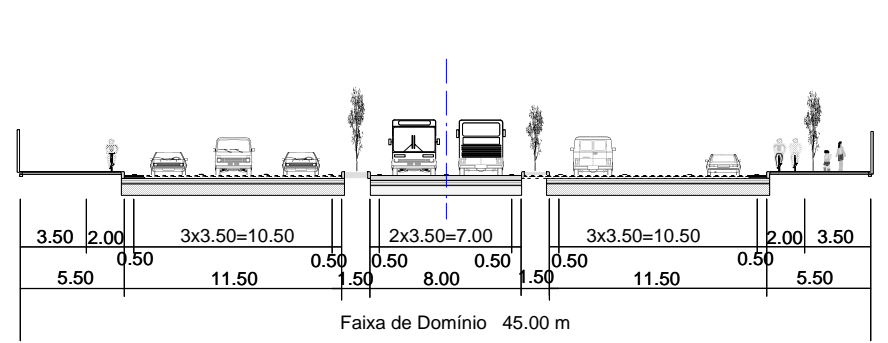
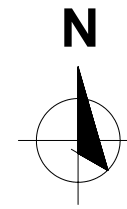

Planta de Interseção

Rodovia Augusto Montenegro x Avenida Independência

GOVERNO DO ESTADO DO PARÁ
SECRETARIA ESPECIAL DE ESTADO DE
INTEGRAÇÃO REGIONAL
(SEIR)

AGÊNCIA DE COOPERAÇÃO
INTERNACIONAL DO JAPÃO
(JICA)

ESTUDO DE VIABILIDADE ECONÔMICA DE PROJETOS PARA O MELHORAMENTO
DO SISTEMA DE TRANSPORTE NA REGIÃO METROPOLITANA DE BELÉM

DATA
ESCALA S = 1 : 3,000

DESENHO No.
PÁGINA No. 36

ELEVAÇÃO 1:300 Avenida Independência - Ponte 1

SEÇÃO 1:300

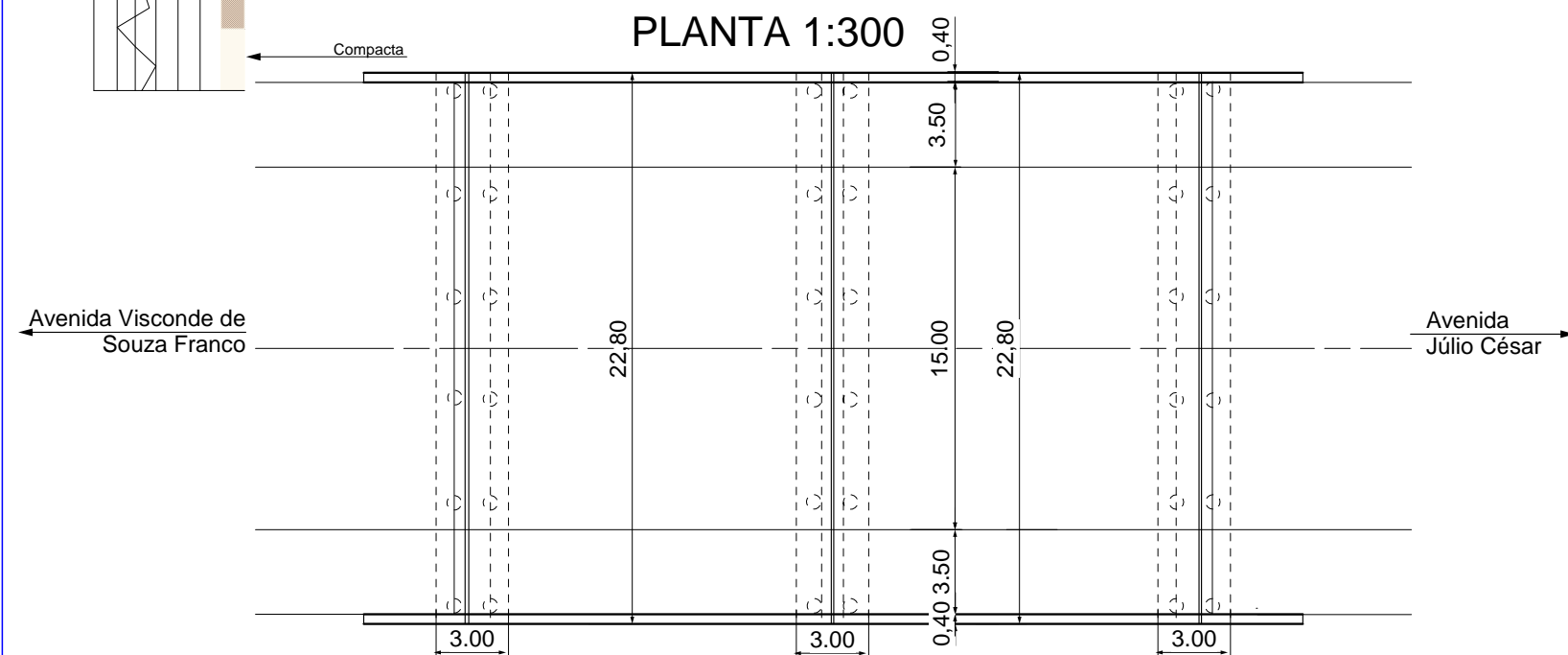
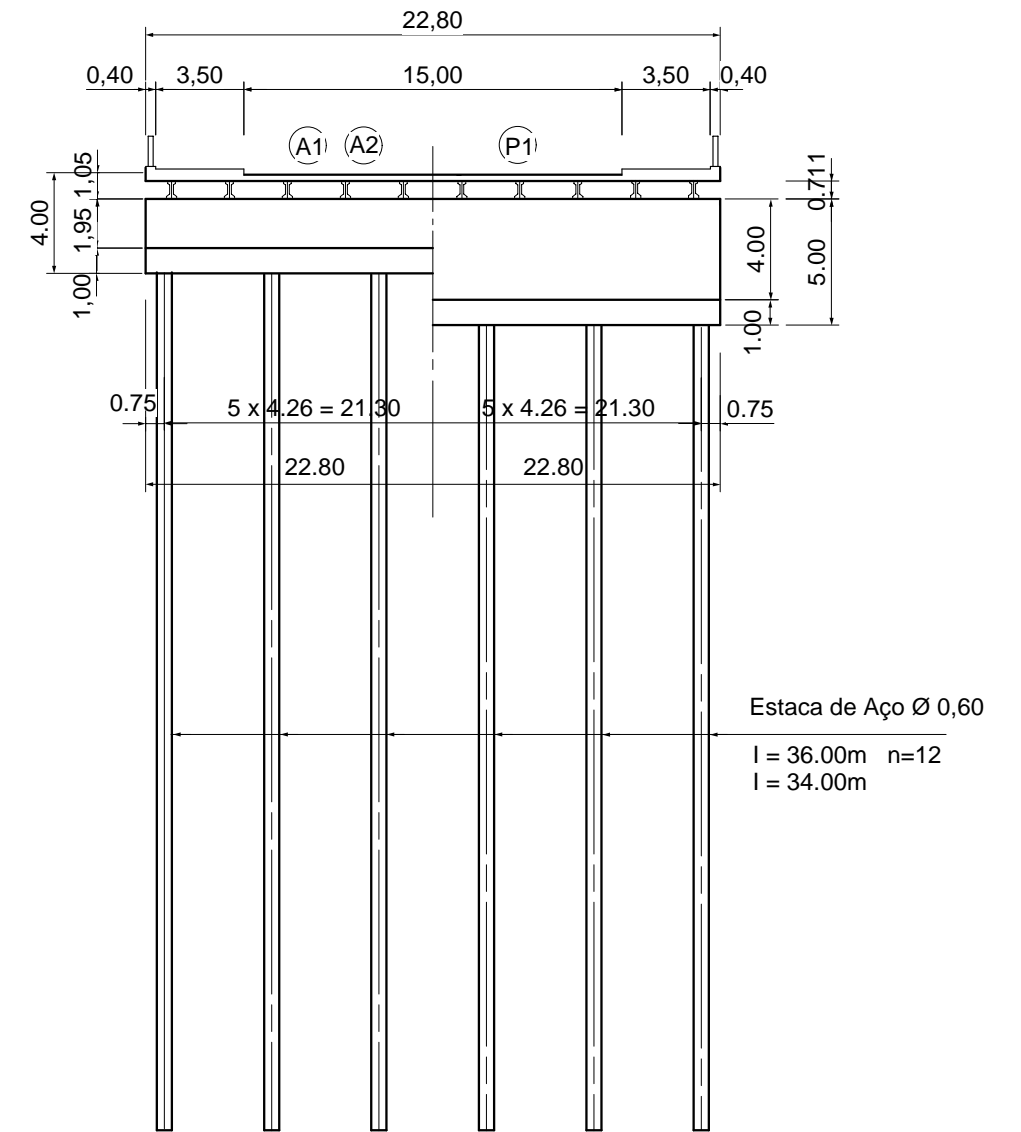
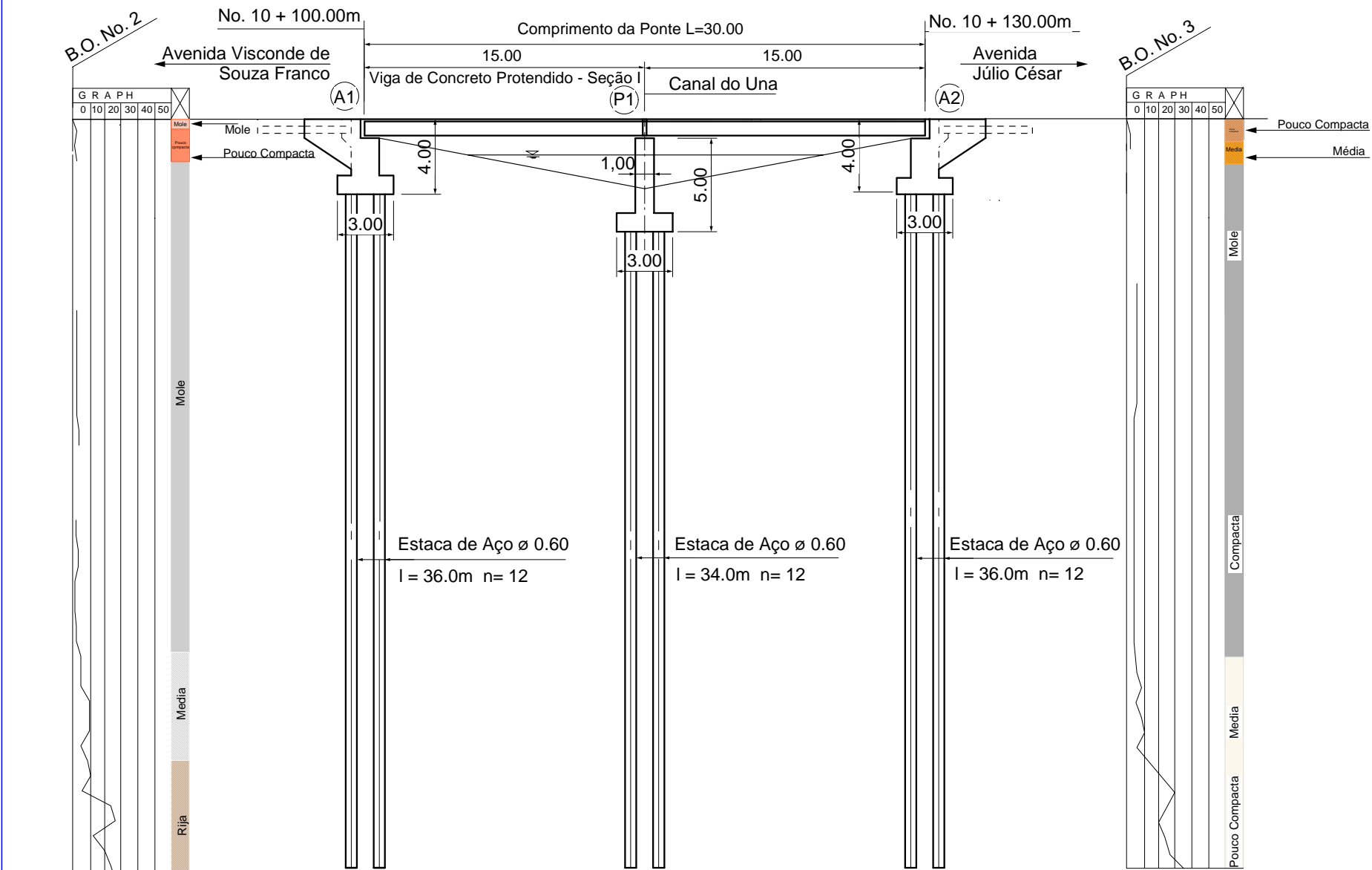

Avenida Independência
Ponte 1

GOVERNO DO ESTADO DO PARÁ
SECRETARIA ESPECIAL DE ESTADO DE
INTEGRAÇÃO REGIONAL
(SEIR)

AGÊNCIA DE COOPERAÇÃO
INTERNACIONAL DO JAPÃO
(JICA)

ESTUDO DE VIABILIDADE ECONÔMICA DE PROJETOS PARA O MELHORAMENTO
DO SISTEMA DE TRANSPORTE NA REGIÃO METROPOLITANA DE BELÉM

DATA
ESCALA

DESENHO No.
PÁGINA No. 37

Avenida Independência - Ponte 2

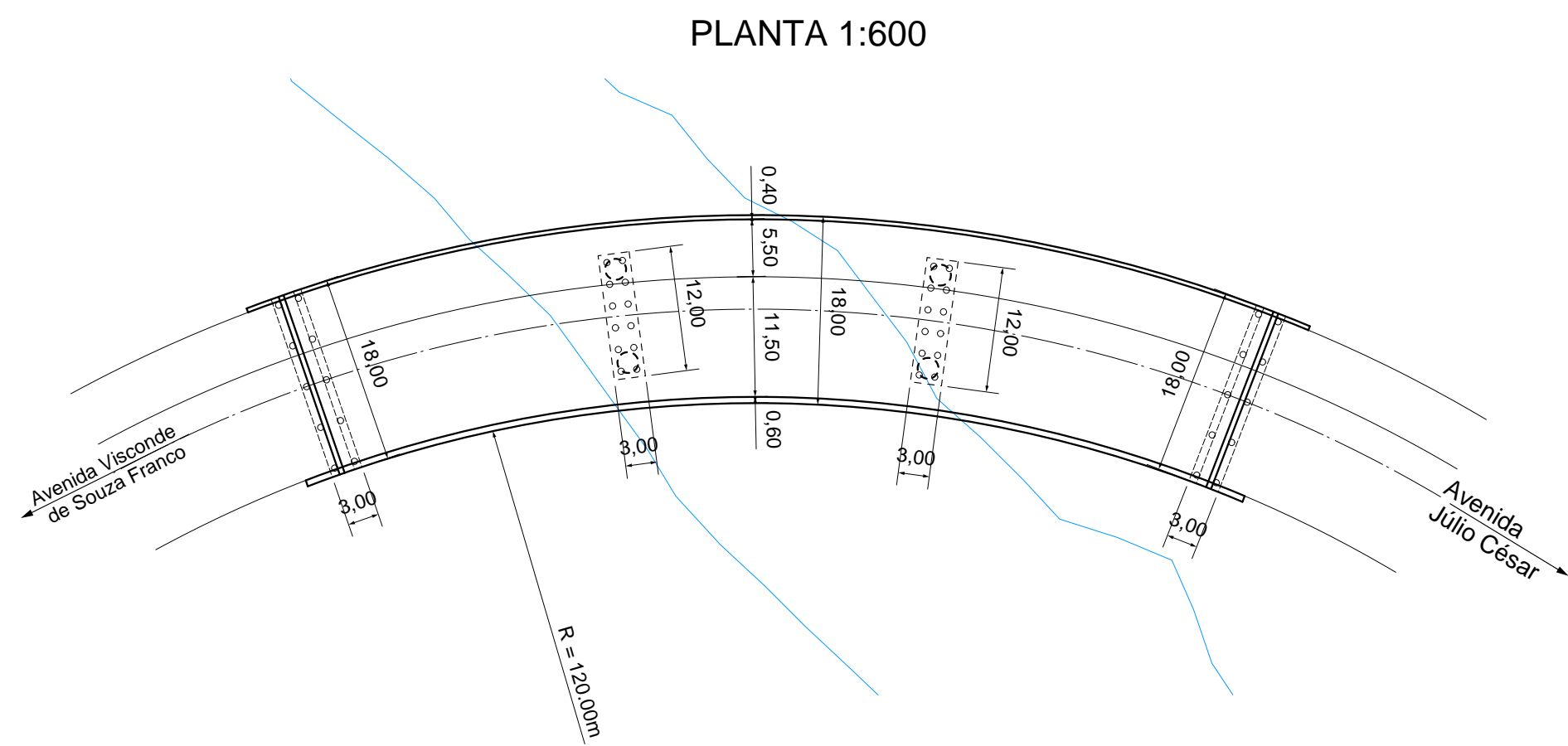
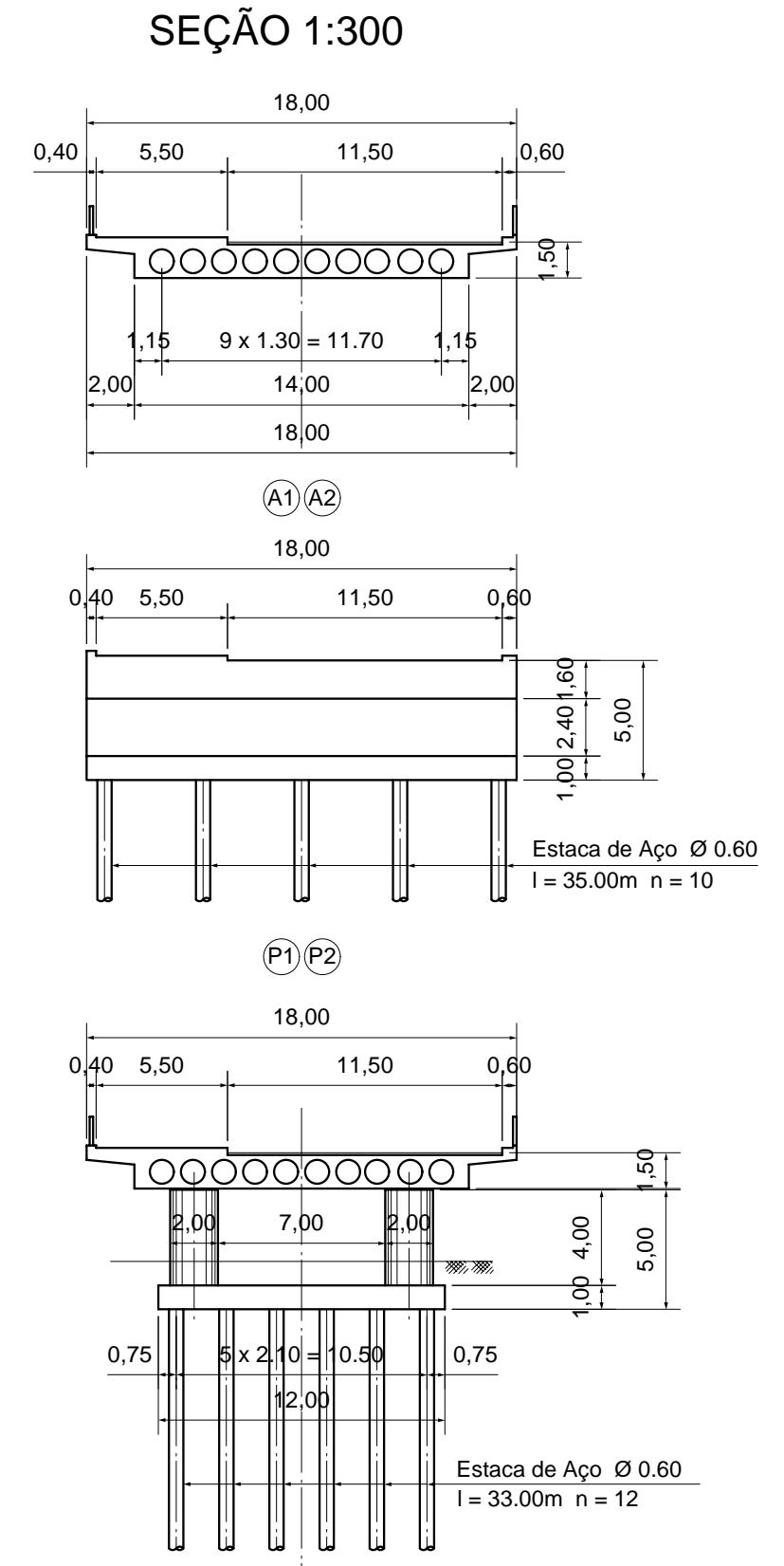
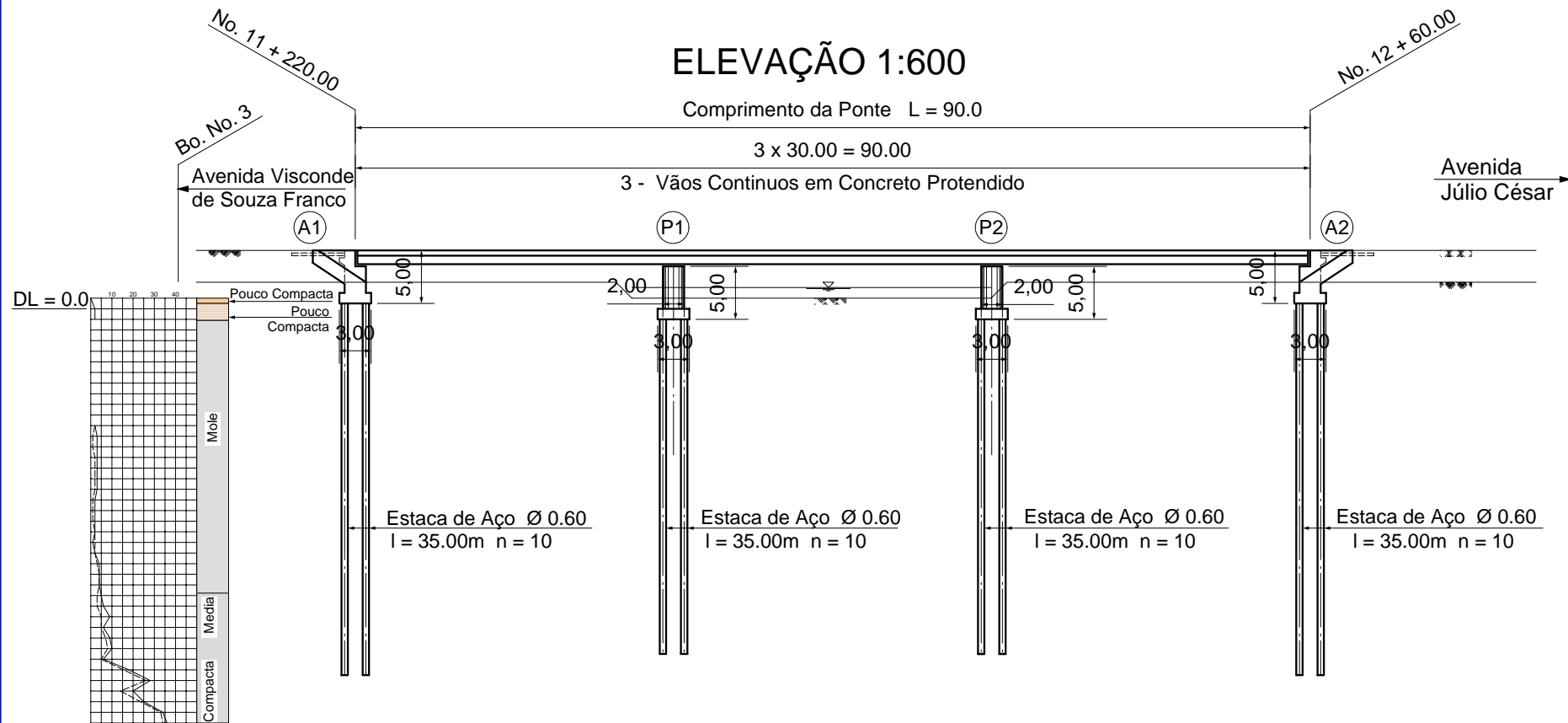

Avenida Independência - Ponte 3 - (1/7)

(A partir da Avenida Visconde de Souza Franco)

ELEVAÇÃO 1:600

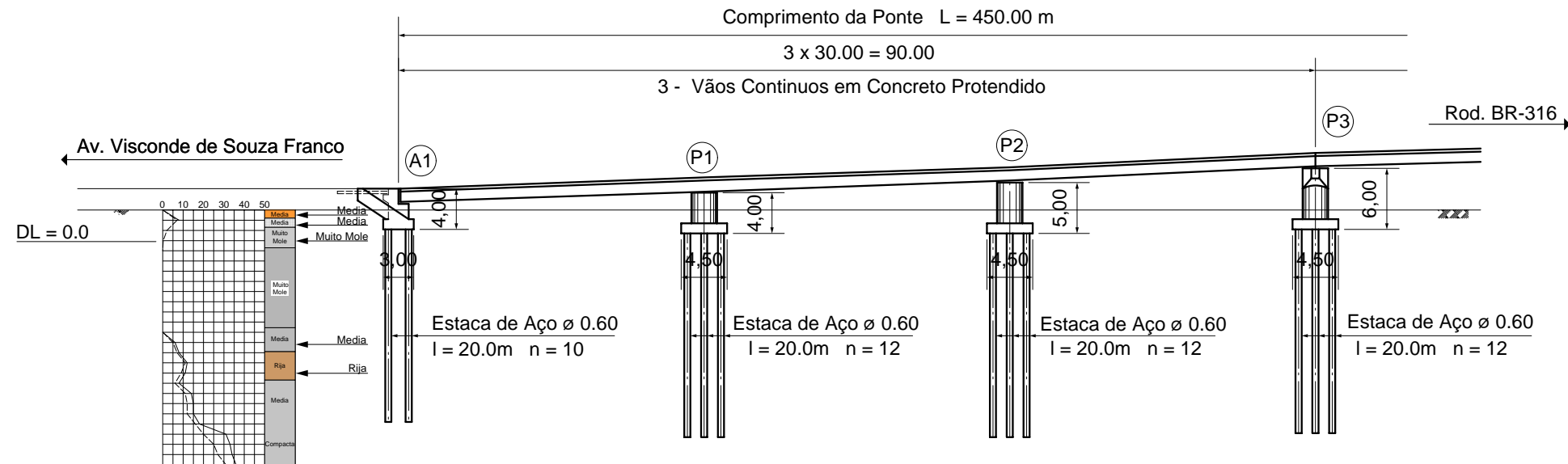

PLANTA 1:600

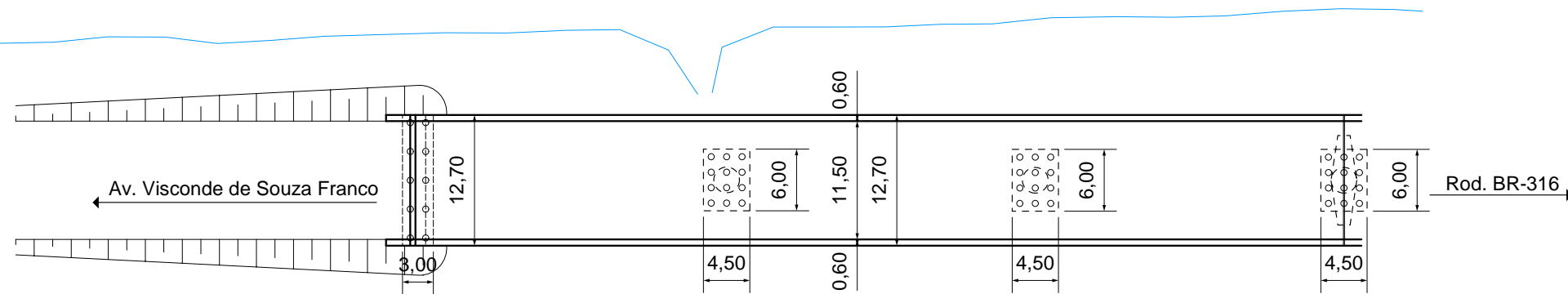

SEÇÃO 1:200

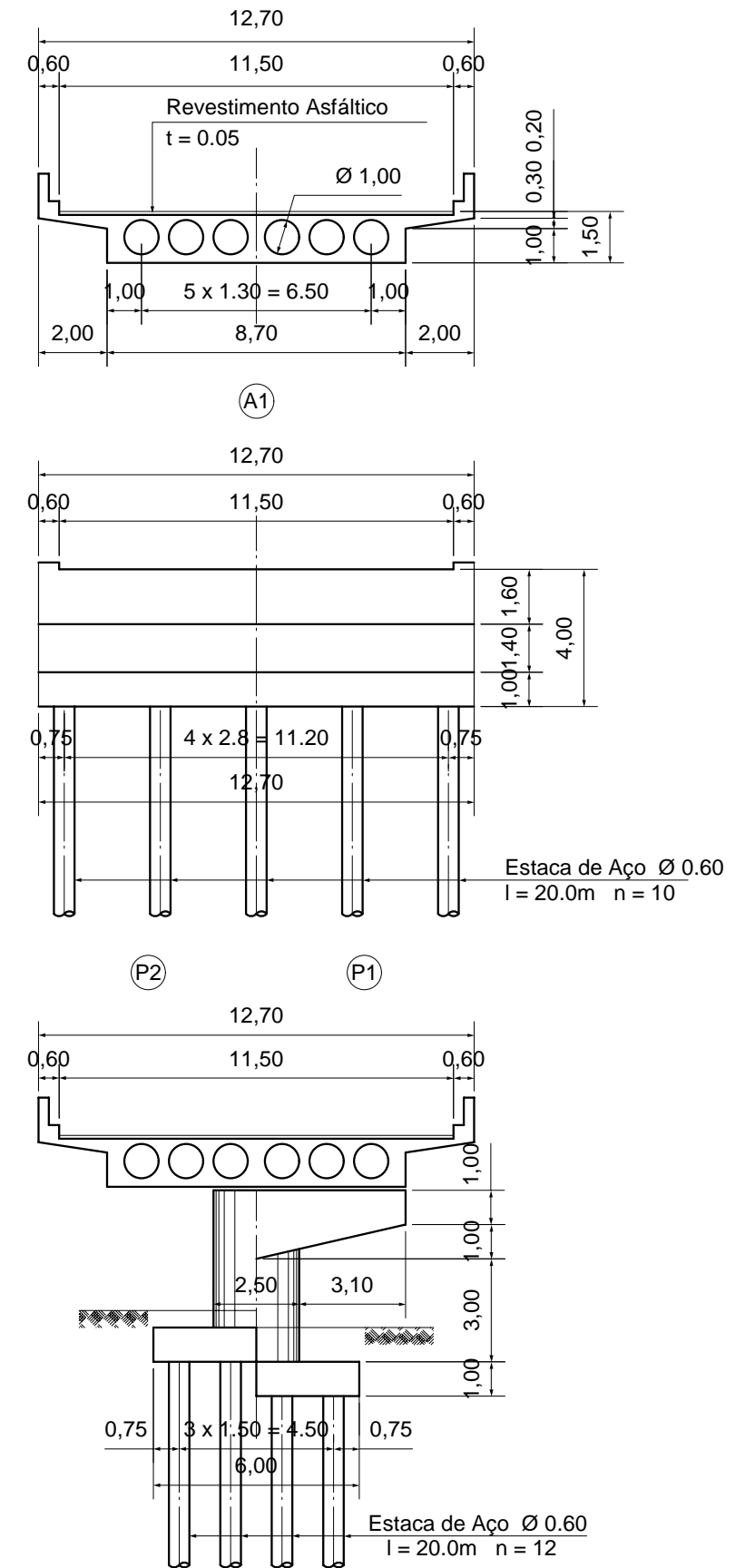

Avenida Independência - Ponte 3 - (2/7)

(A partir da Avenida Visconde de Souza Franco)

ELEVAÇÃO 1:600

Comprimento da Ponte L = 450.00

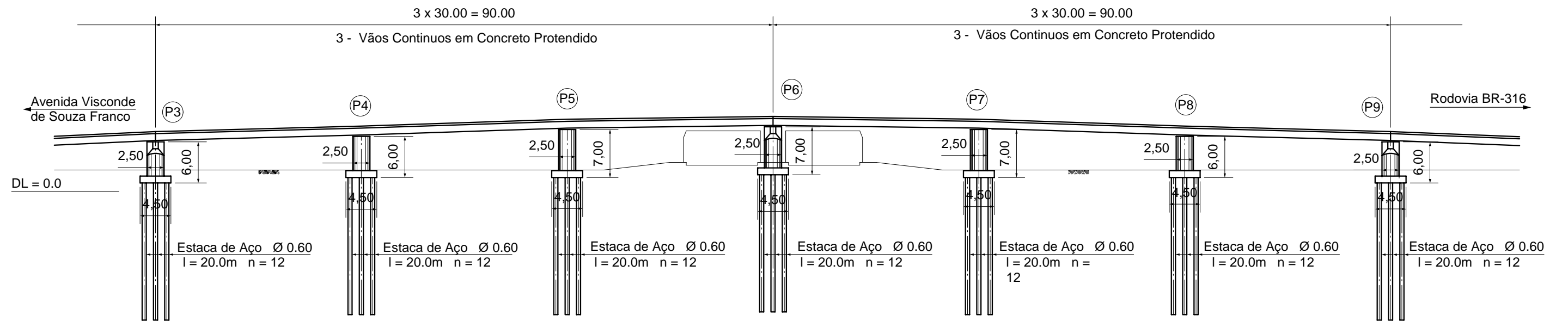

PLANTA 1:600

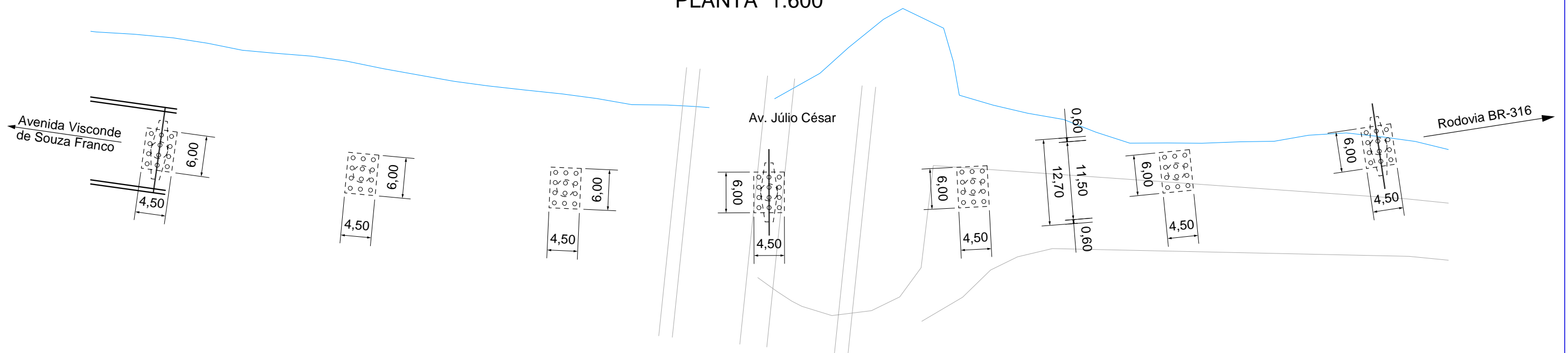

Avenida Independência - Ponte 3 - (3/7)

(A partir da Avenida Júlio César)

ELEVAÇÃO 1:600

Comprimento da Ponte L = 450.00

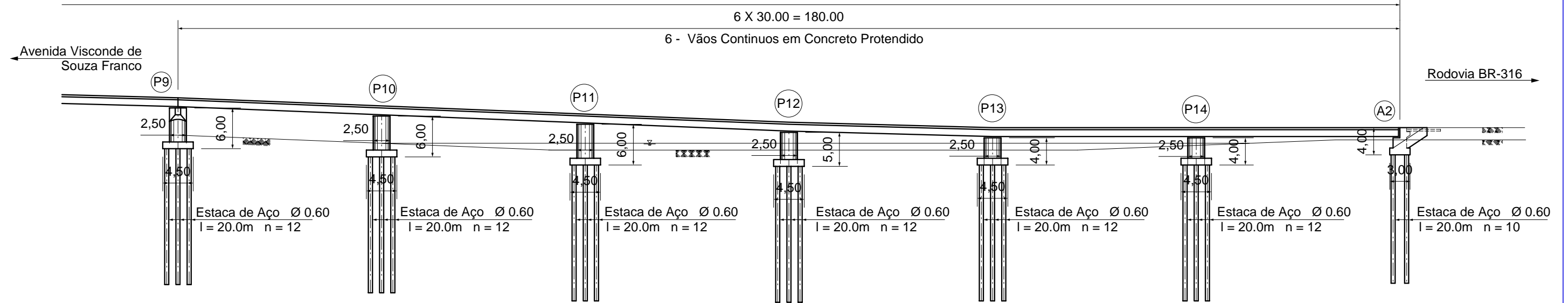

PLANTA 1:600

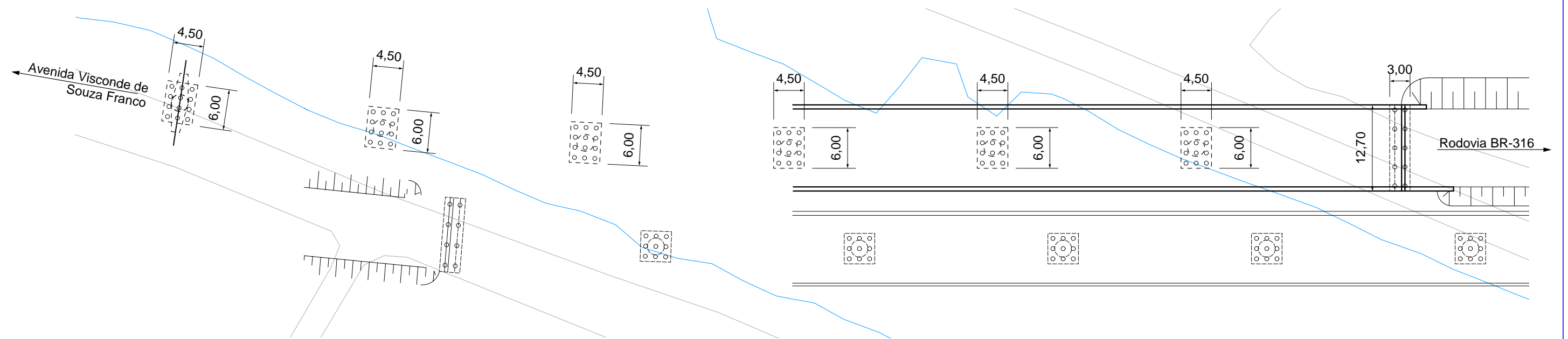

Avenida Independência - Ponte 3 - (4/7)

(A partir da Rodovia BR-316)

ELEVAÇÃO 1:600

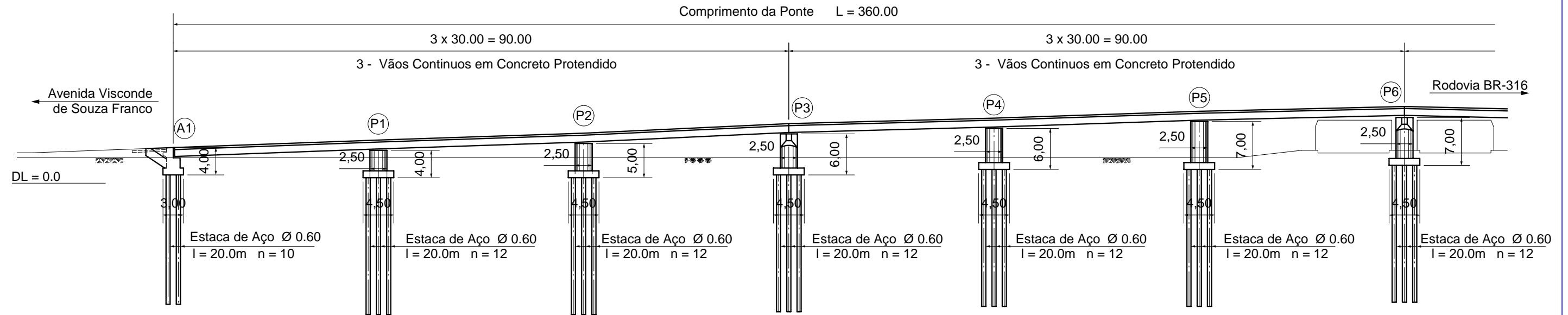

PLANTA 1:600

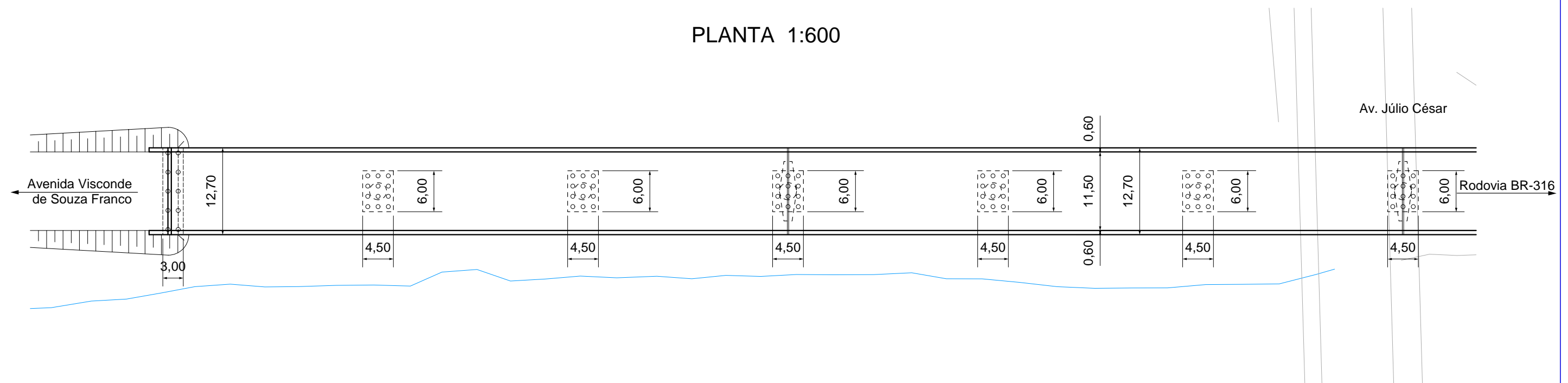

Avenida Independência - Ponte 3 - (5/7)

(A partir da Rodovia BR-316)

ELEVAÇÃO 1:600

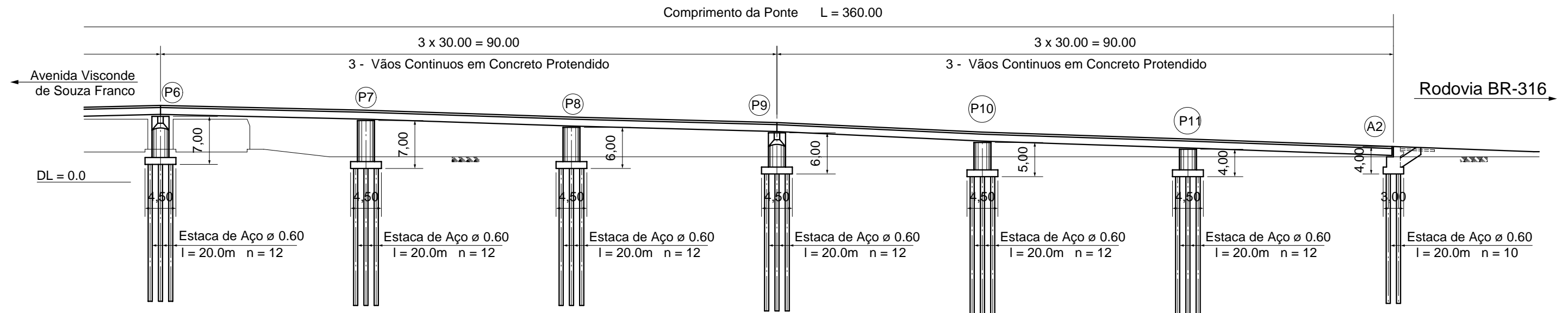

PLANTA 1:600

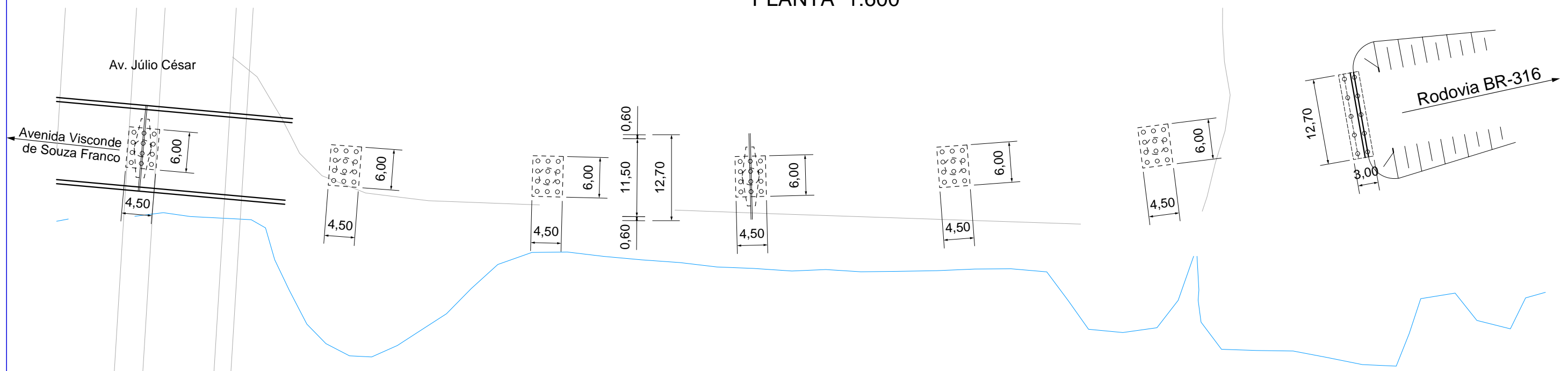

Avenida Independência - Ponte 3 - (6/7)

(A partir Avenida Júlio César)

ELEVAÇÃO 1:600

Comprimento da Ponte L = 180.00m

6 x 30.00 = 180.00

6 - Vãos Contínuos em Concreto Protendido

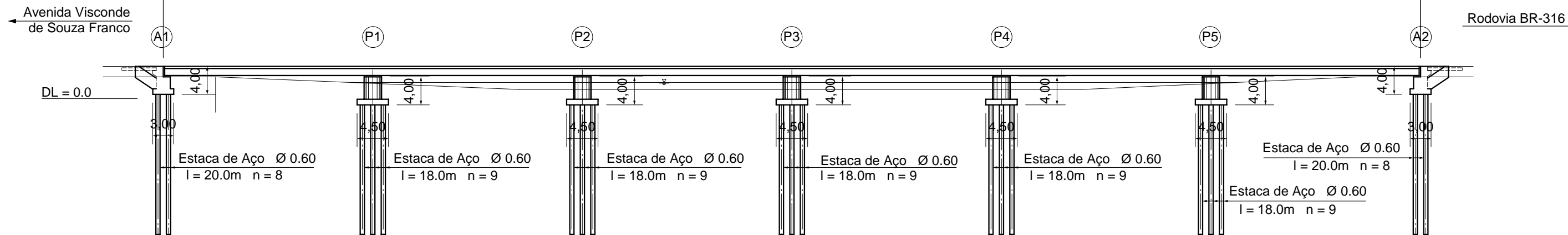

PLANTA 1:600

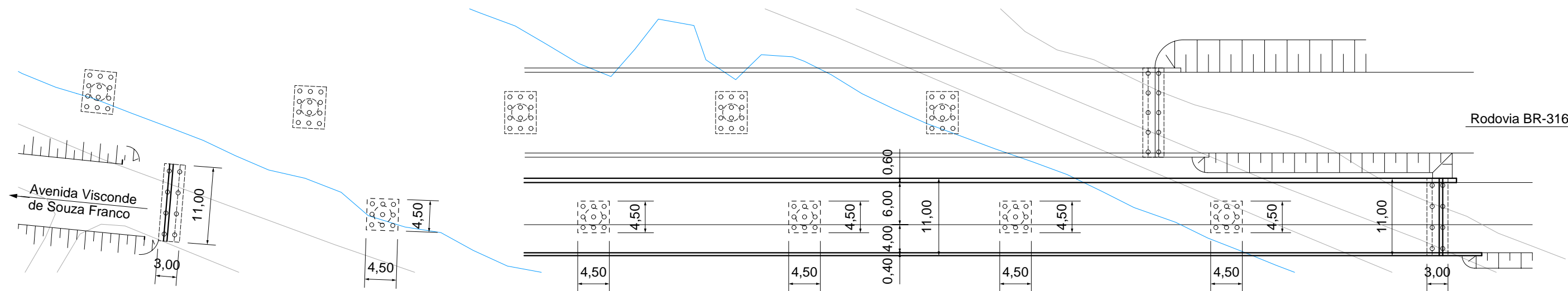

Avenida Independência
Ponte 3 - (6/7)

GOVERNO DO ESTADO DO PARÁ
SECRETARIA ESPECIAL DE ESTADO DE
INTEGRAÇÃO REGIONAL
(SEIR)

AGÊNCIA DE COOPERAÇÃO
INTERNACIONAL DO JAPÃO
(JICA)

ESTUDO DE VIABILIDADE ECONÔMICA DE PROJETOS PARA O MELHORAMENTO
DO SISTEMA DE TRANSPORTE NA REGIÃO METROPOLITANA DE BELÉM

DATA
ESCALA

DESENHO No.
PÁGINA No. 44

Avenida Independência - Ponte 3 - (7/7)

(A partir da Avenida Júlio César)

SEÇÃO 1:300

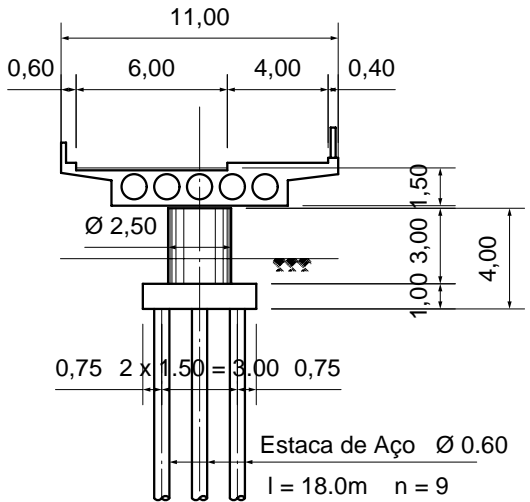
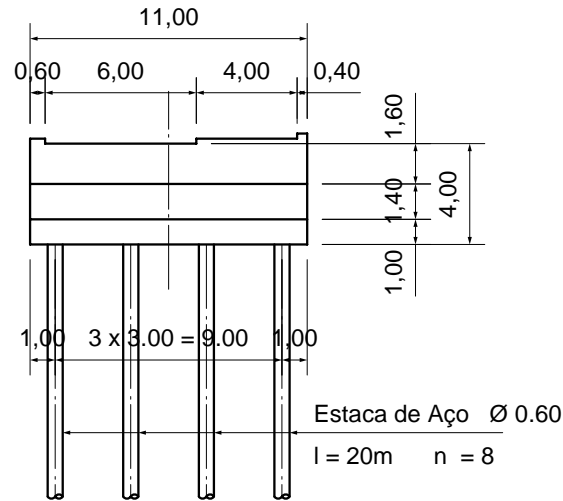
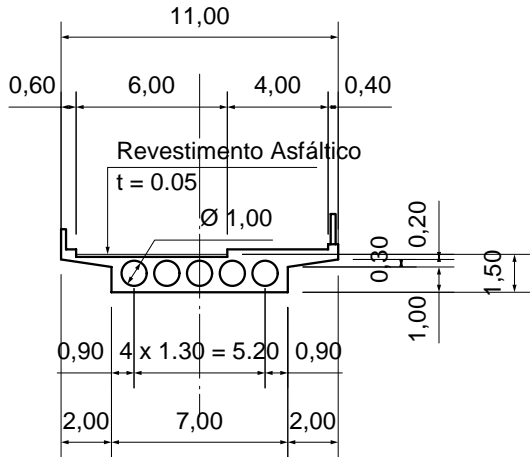

Avenida Independência - Ponte 4

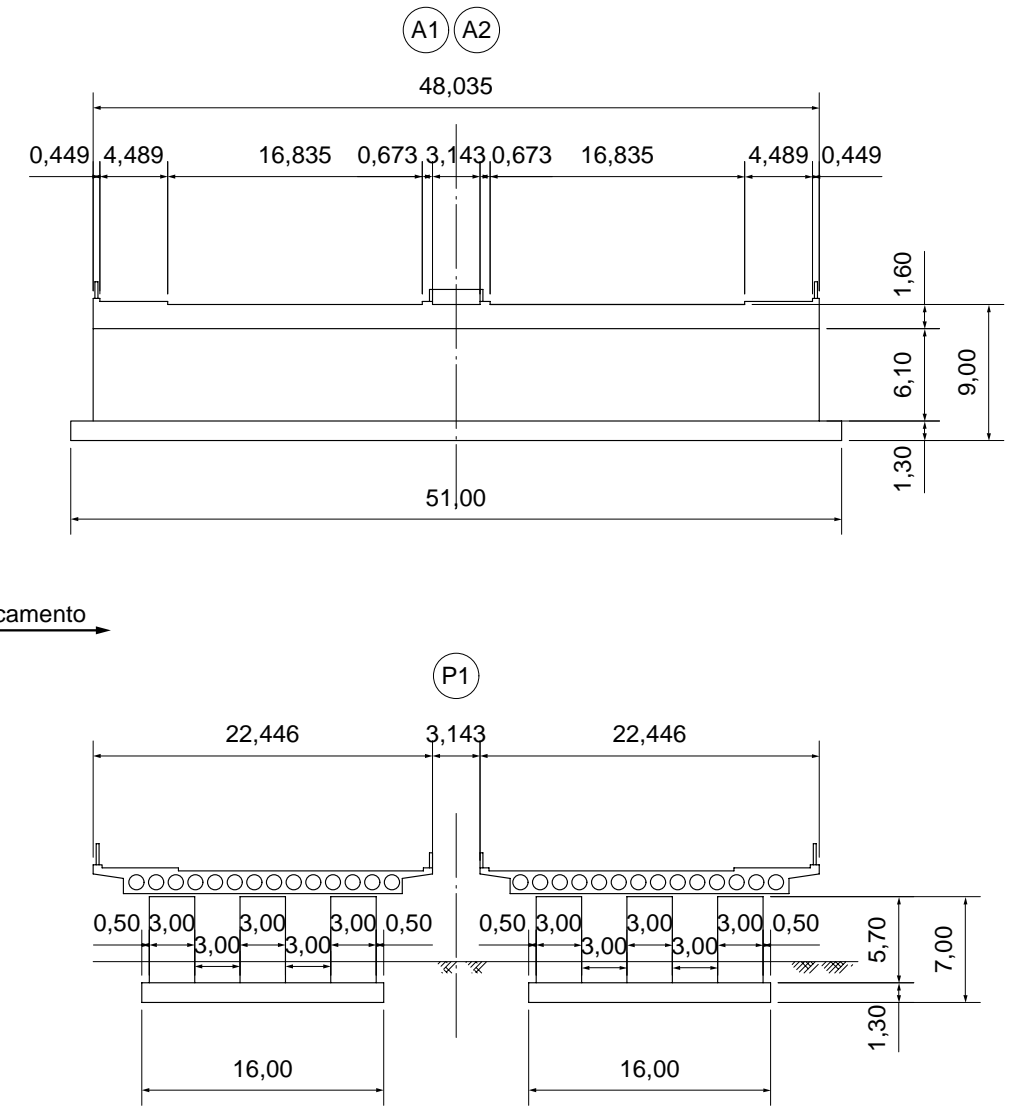
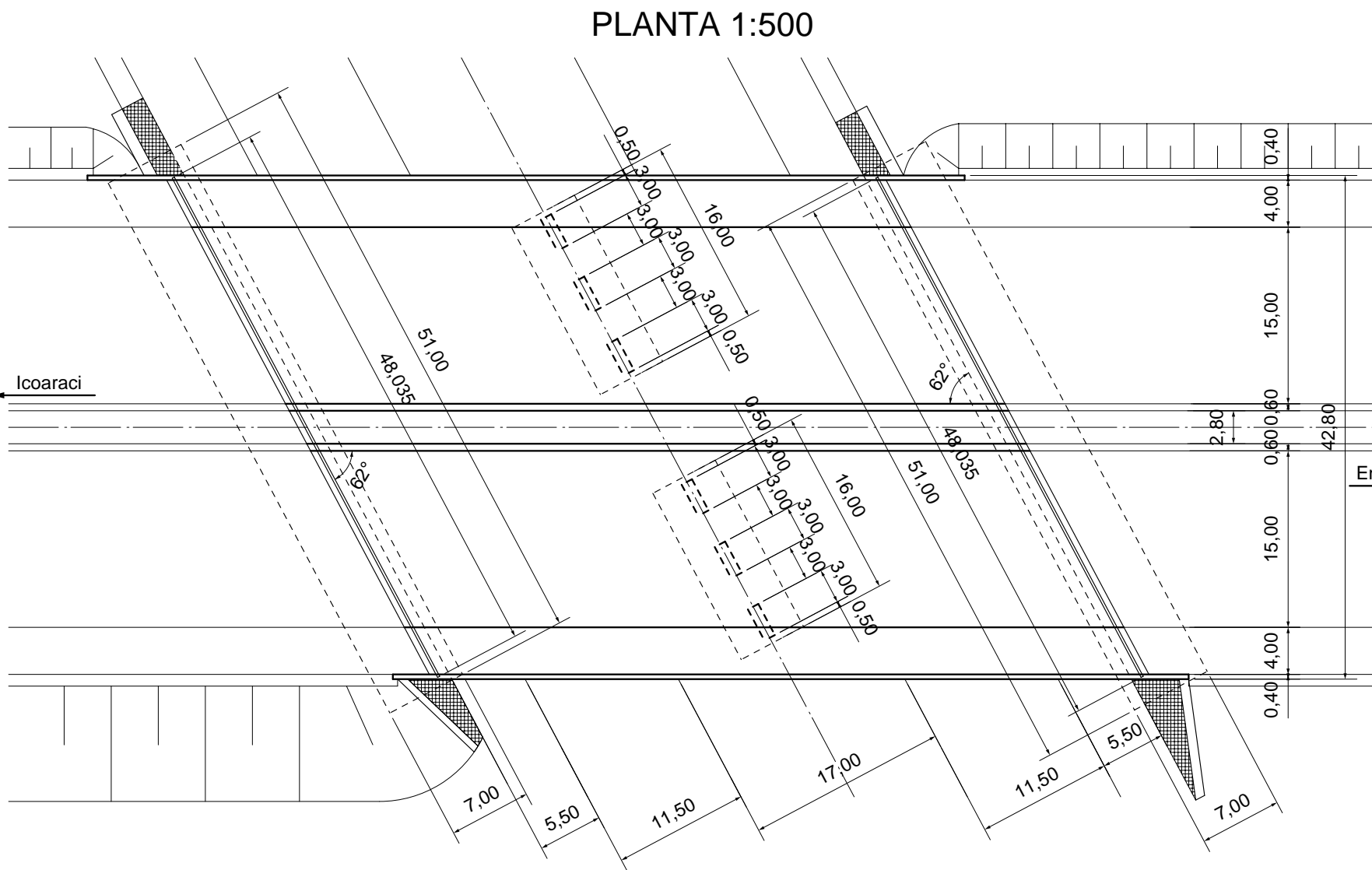
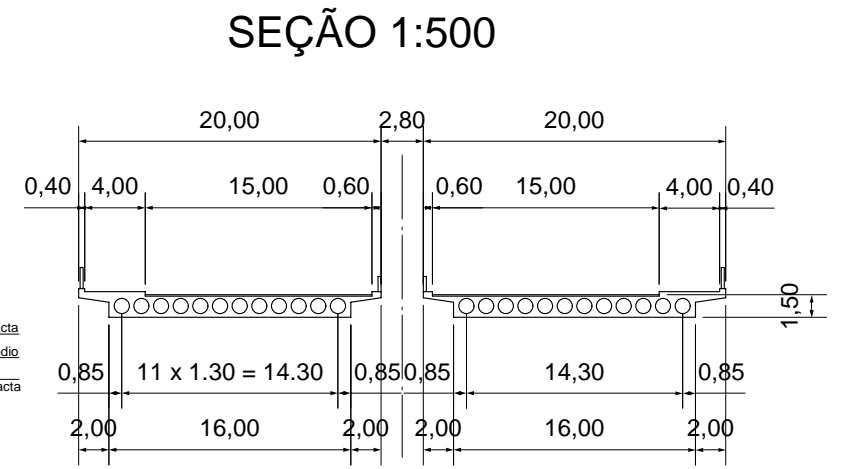
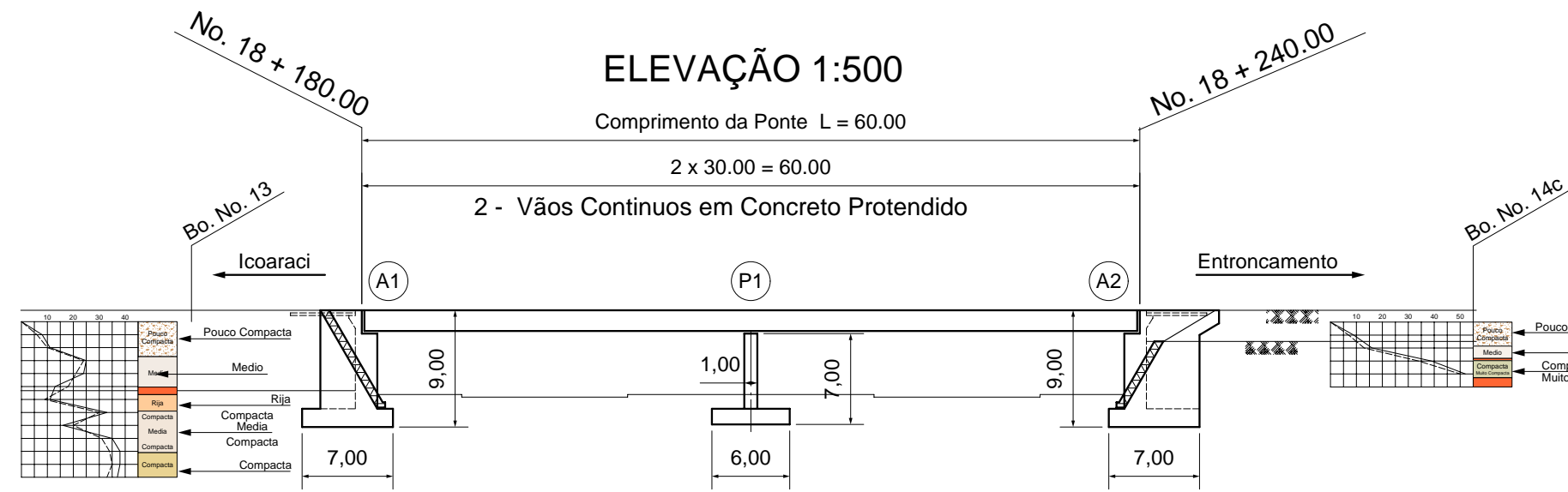

Avenida Independência - Ponte 5 - (1/2)

(A partir da Rodovia BR-316)

ELEVAÇÃO 1:300

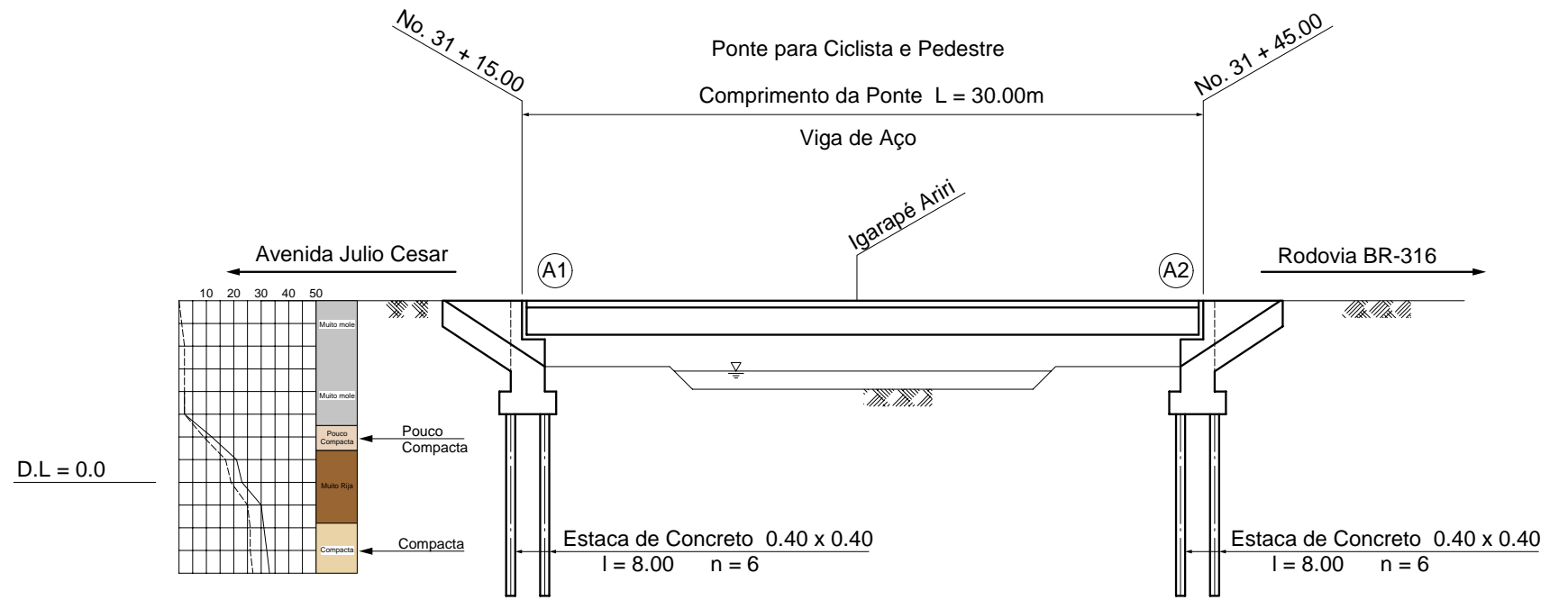

SEÇÃO TRANSVERSAL - SUPERESTRUTURA 1:200

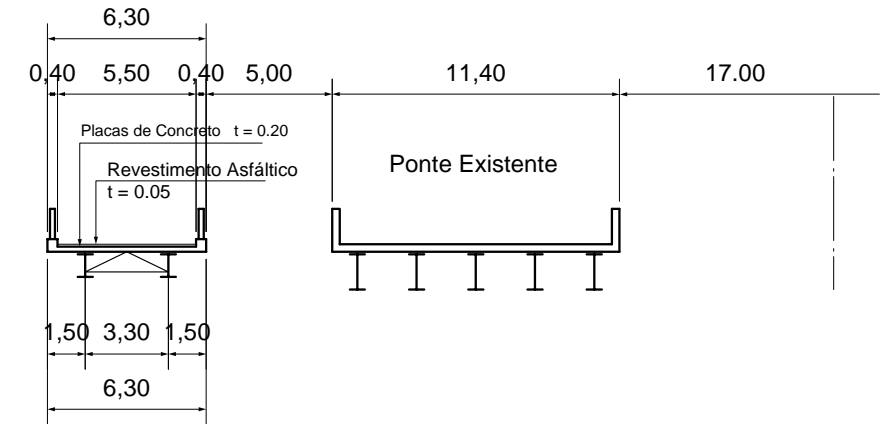

SEÇÃO 1:100

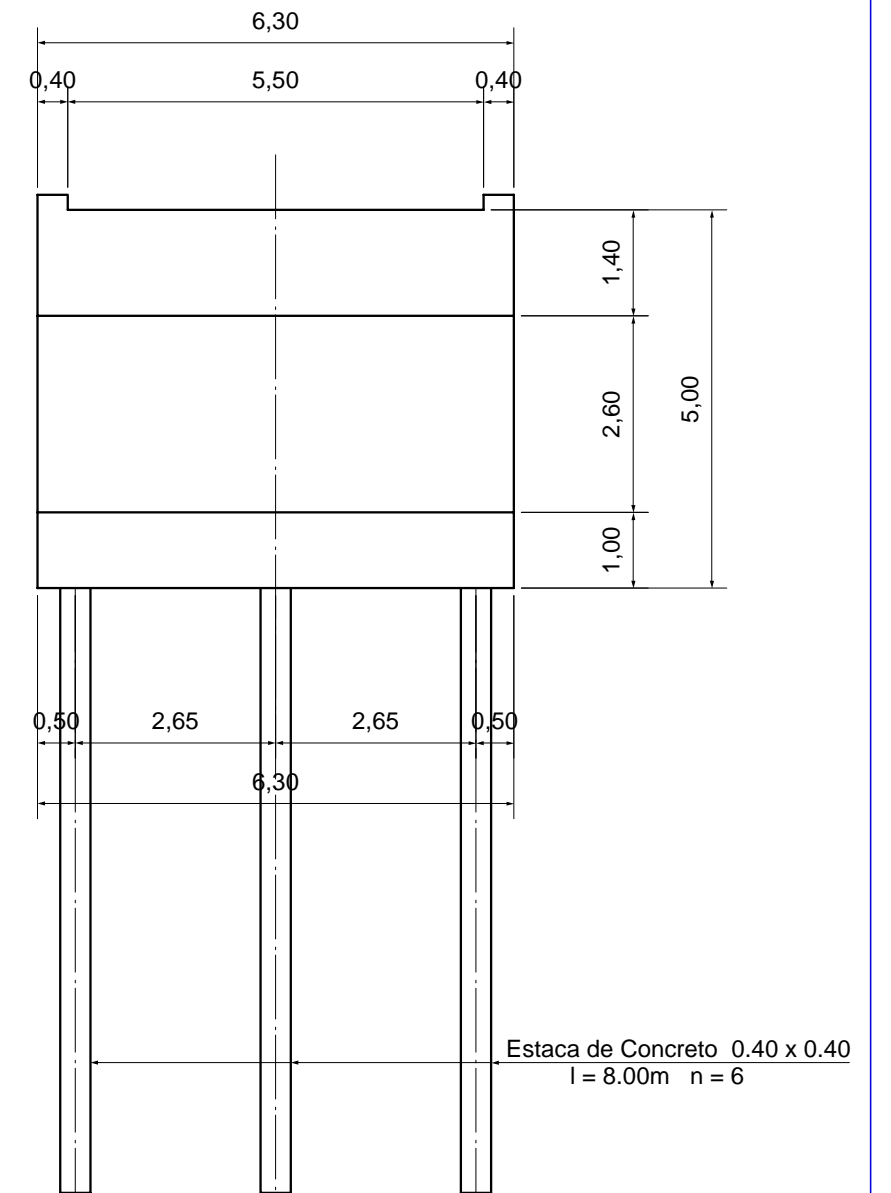

PLANTA 1:300

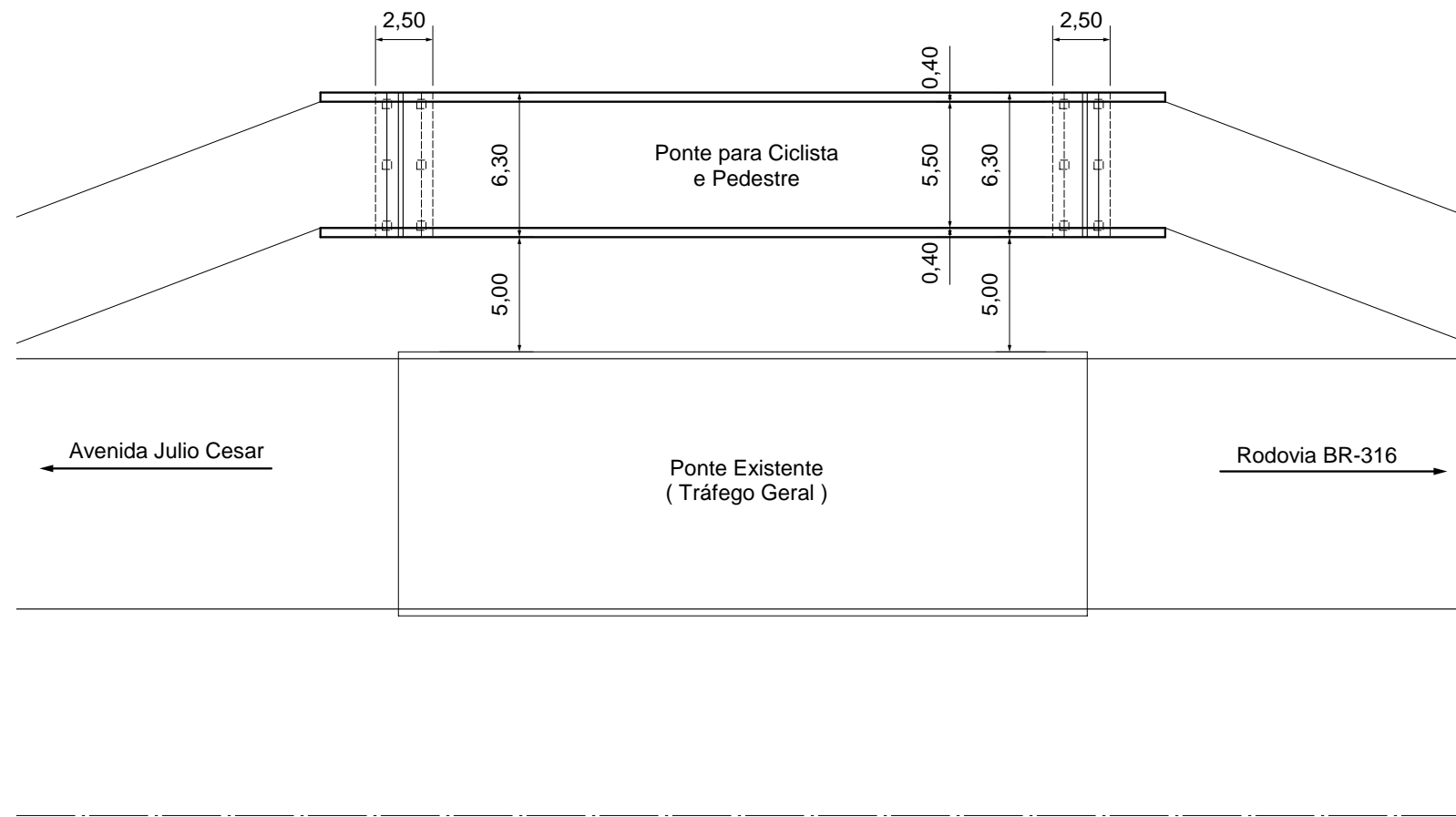

Avenida Independência - Ponte 5 - (2/2)

(A partir da Rodovia BR-316)

ELEVAÇÃO 1:300

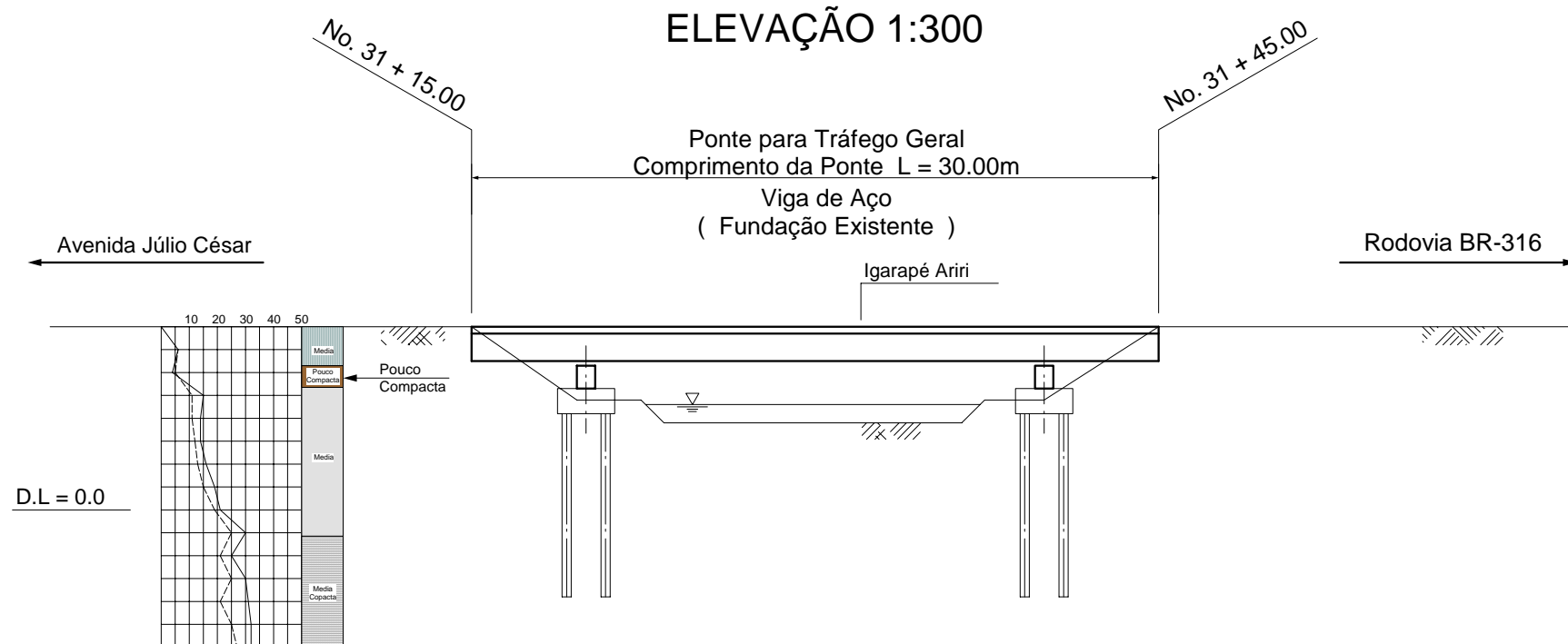

SEÇÃO 1:300

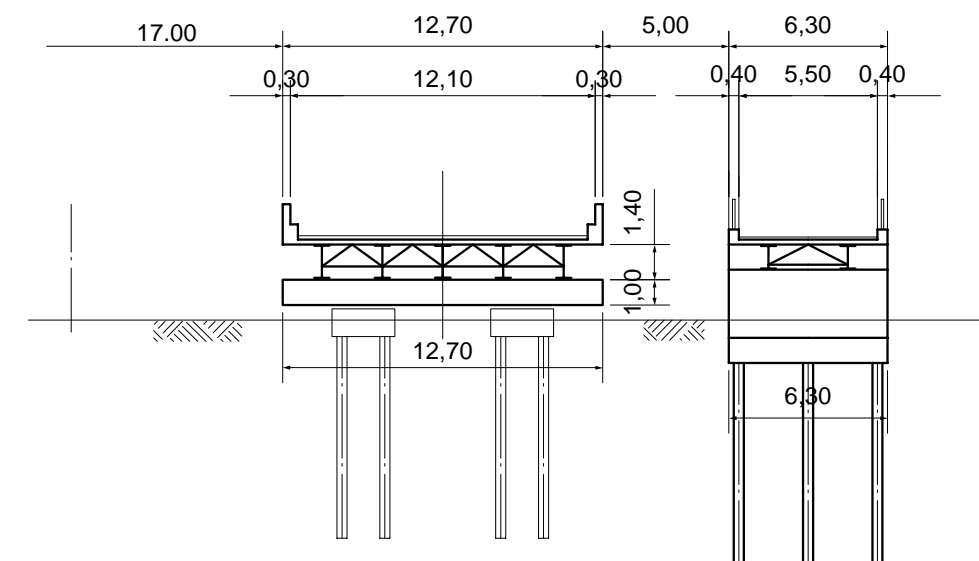

PLANTA 1:300

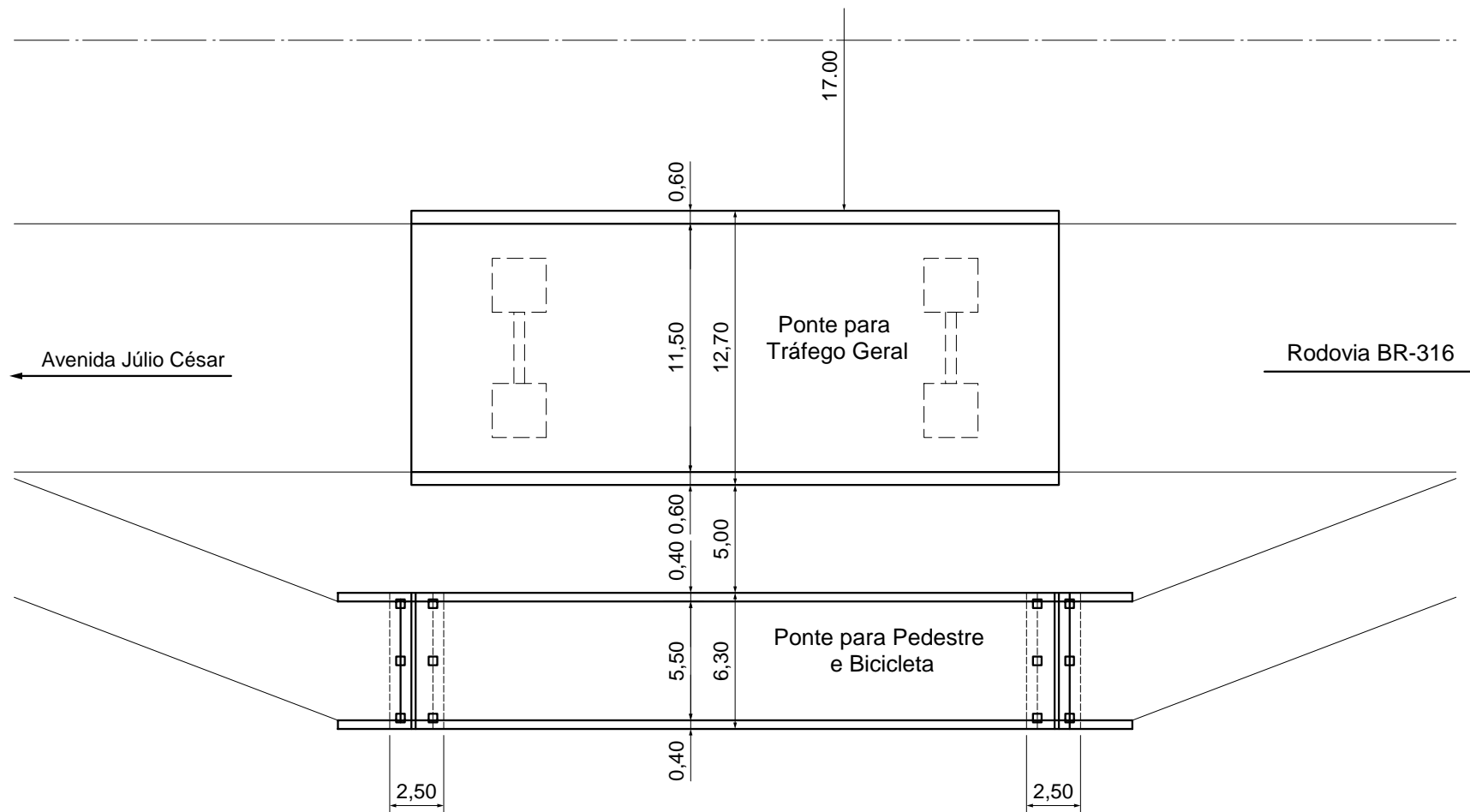

Avenida Independência - Ponte 6

ELEVAÇÃO 1:300

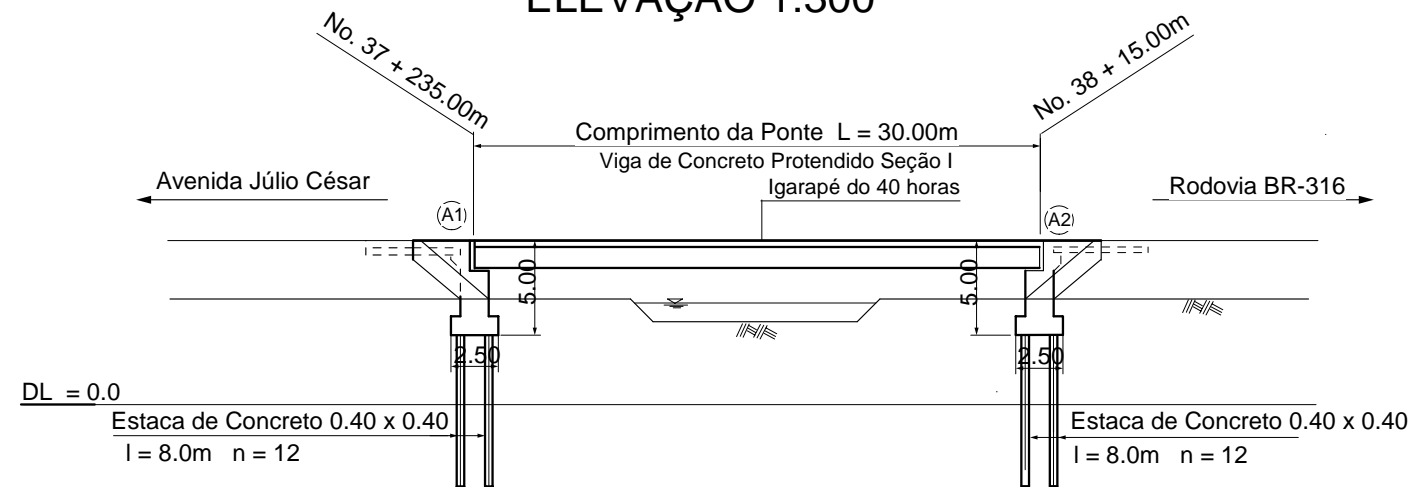

PLANTA 1:300

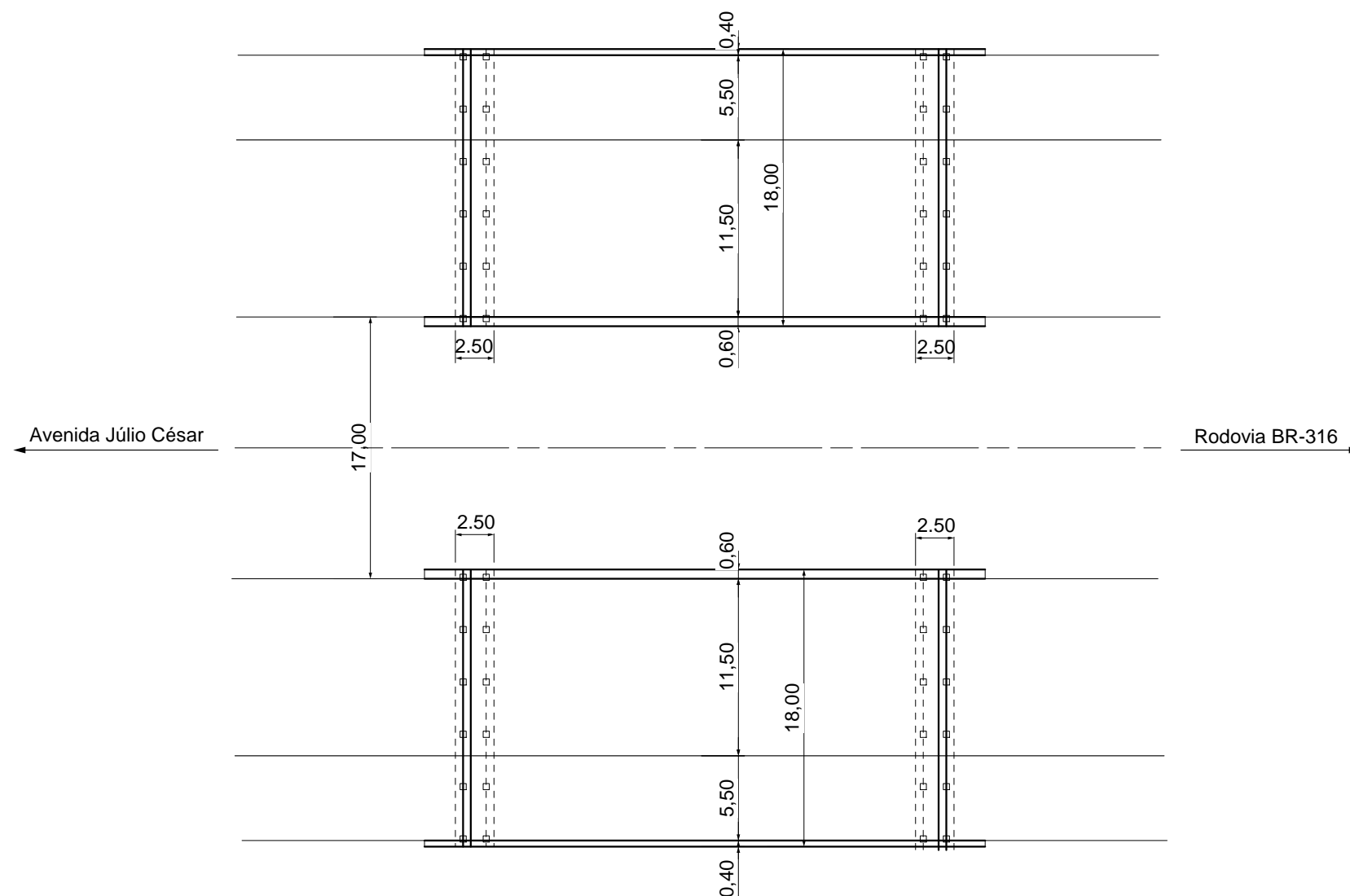

SEÇÃO TRANSVERSAL - SUPERESTRUTURA 1:200

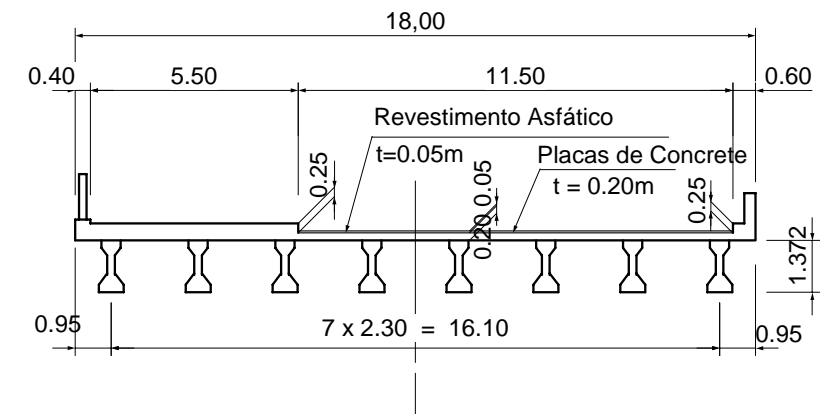

SEÇÃO 1:500

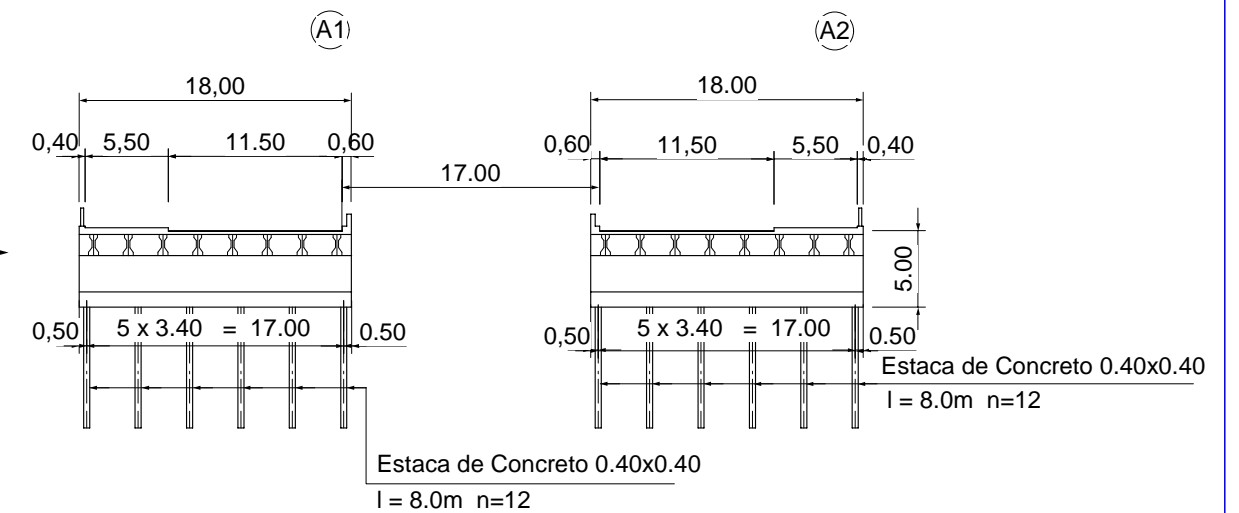

Avenida Independência - Ponte 7

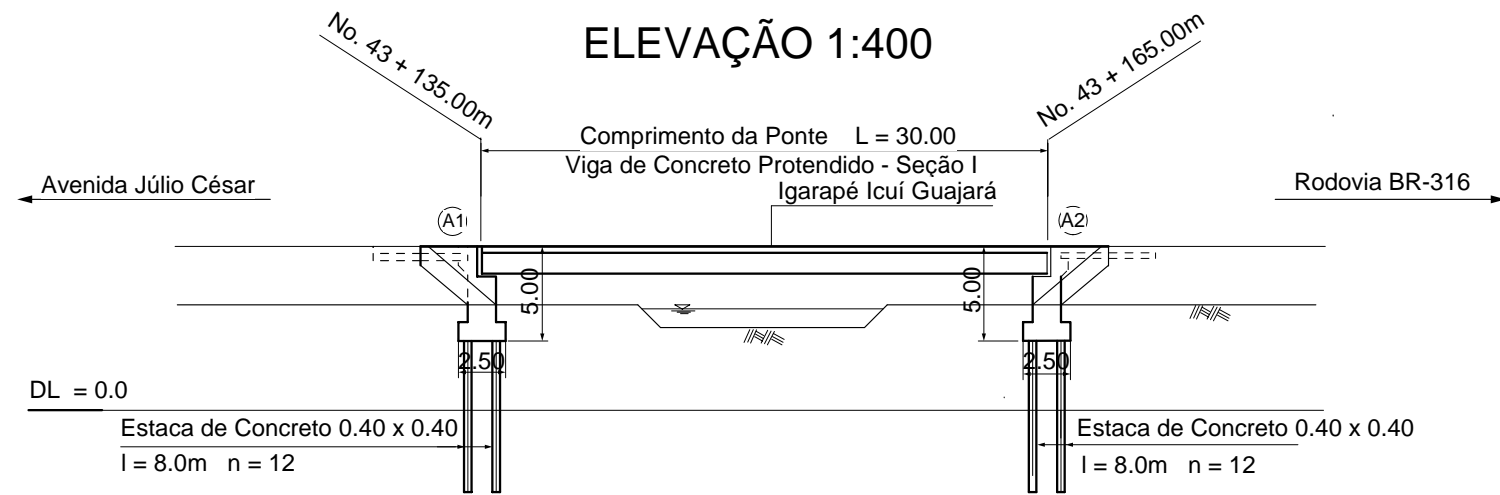

SEÇÃO TRANSVERSAL - SUPERESTRUTURA 1:200

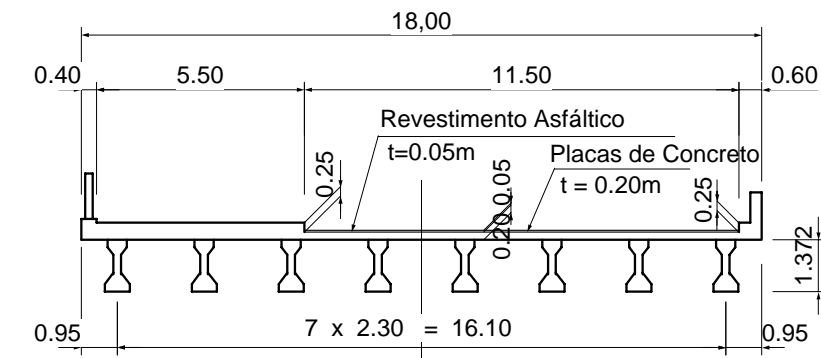

PLANTA 1:400

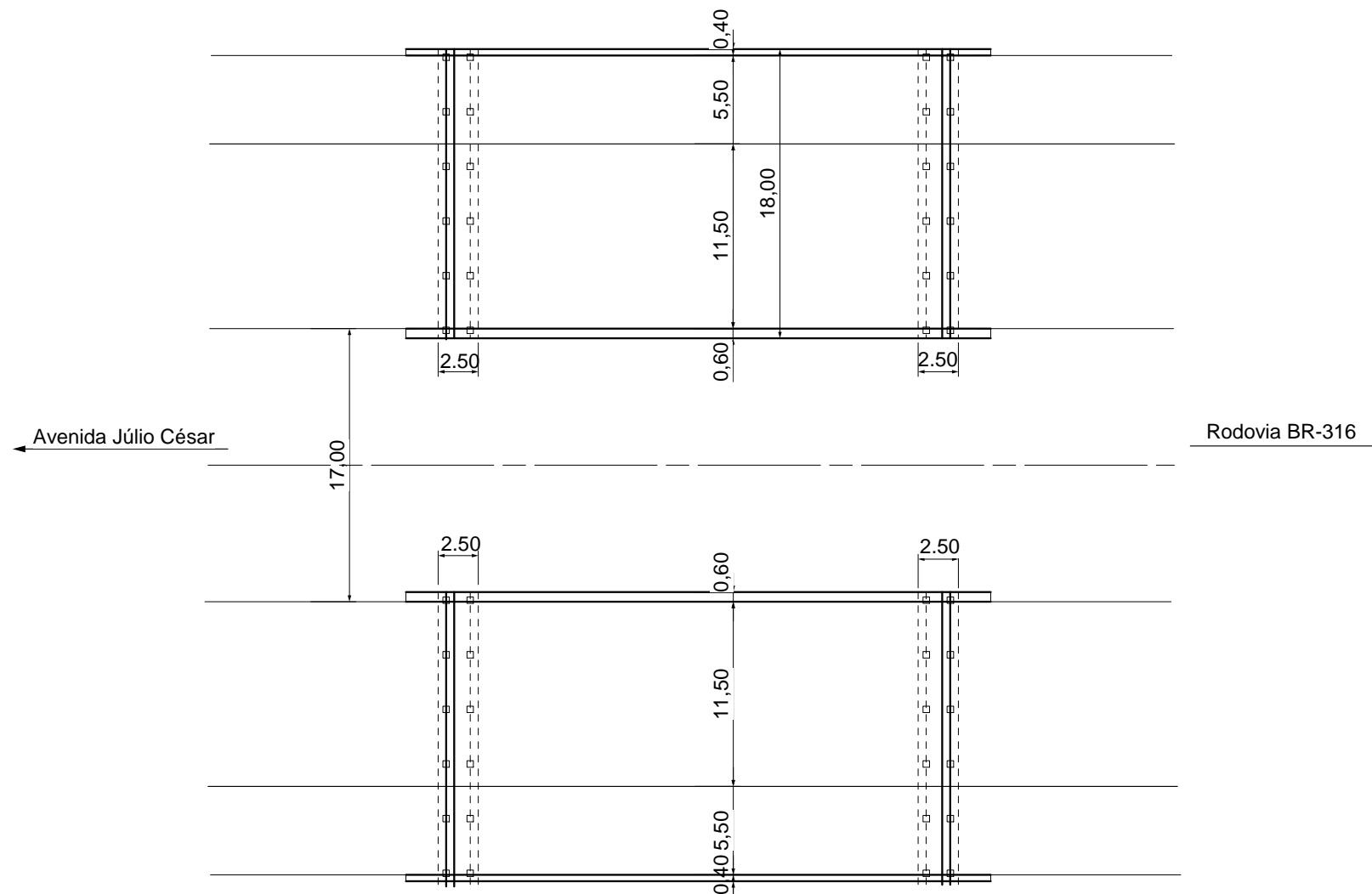

SEÇÃO 1:500

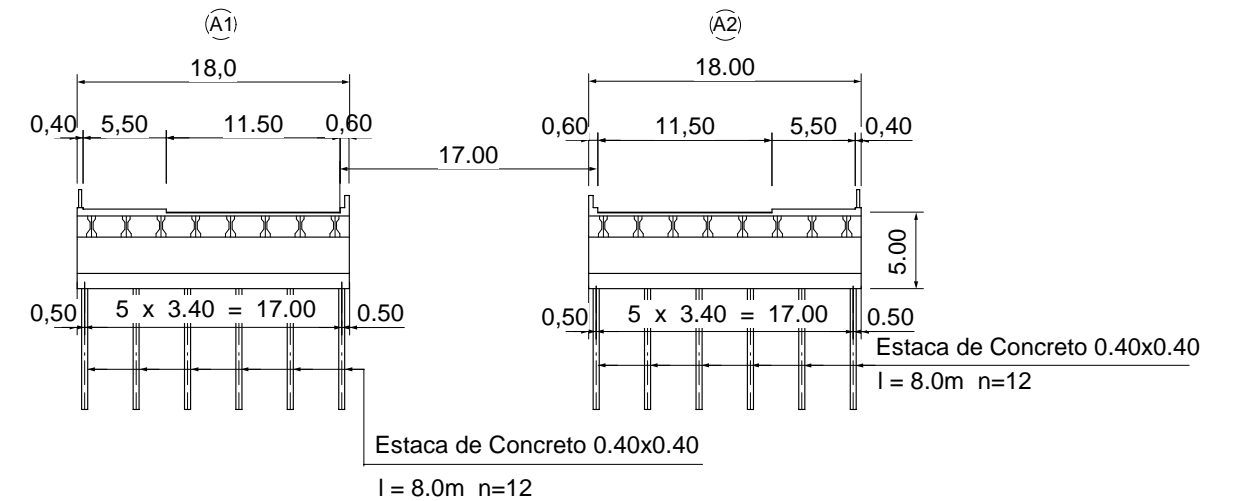

Avenida Independência - Ponte 8

ELEVAÇÃO 1: 500

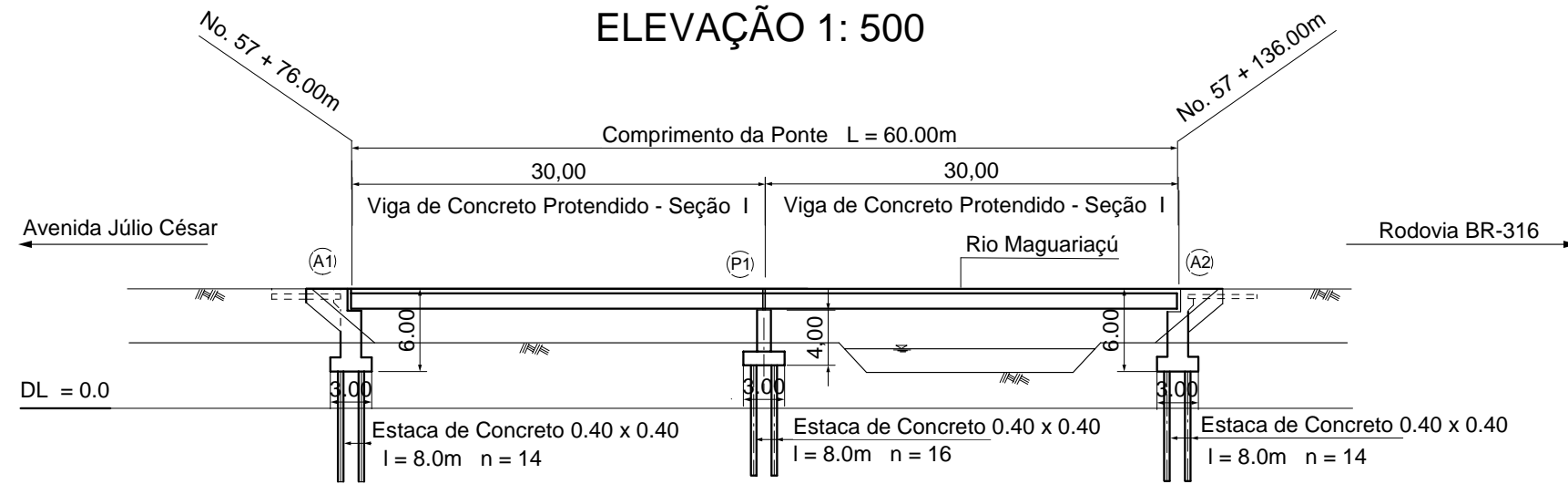

SEÇÃO 1:300

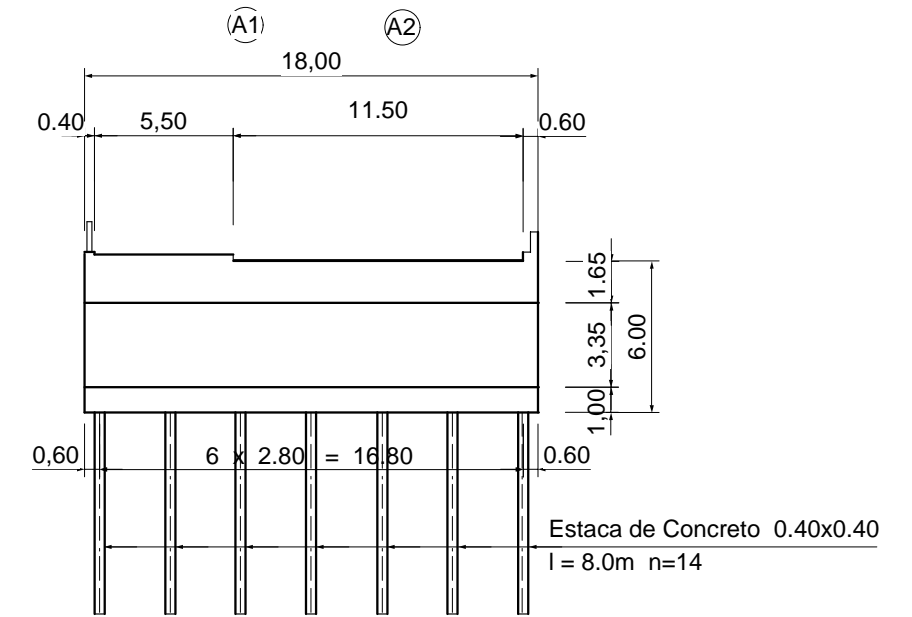

PLANTA 1: 500

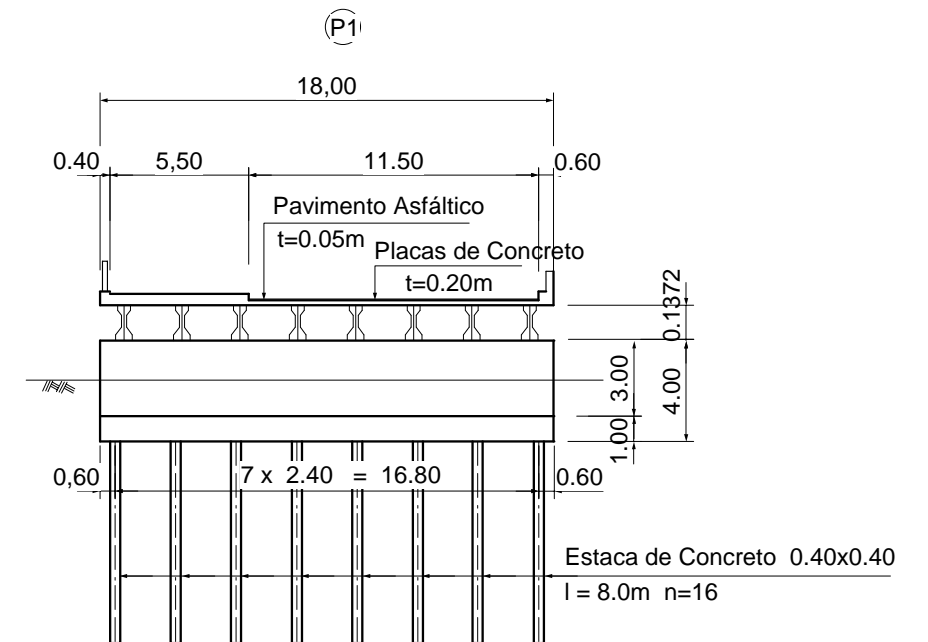
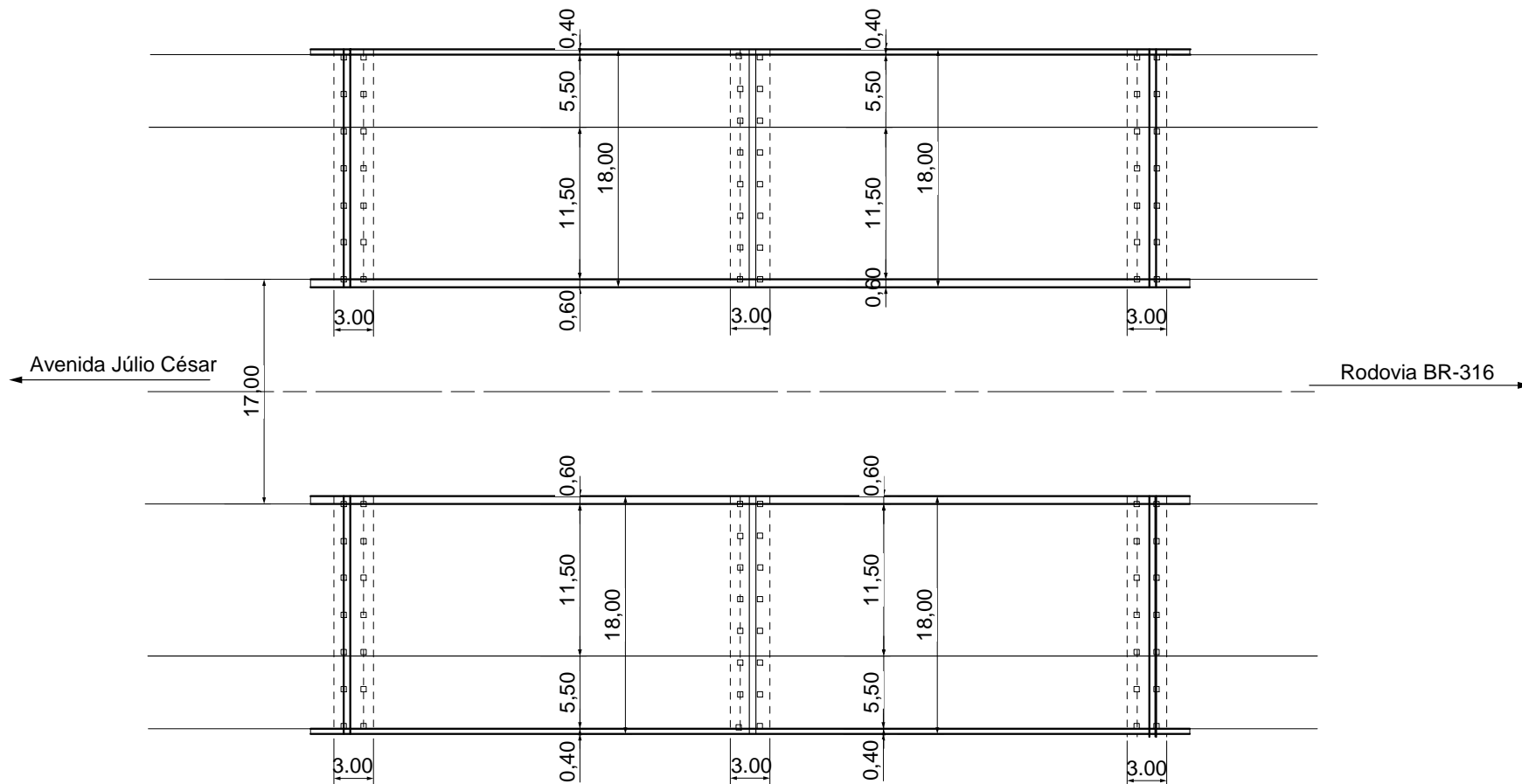

Avenida Independência - Detalhe de Ponte

Estrutura Celular em Concreto Protendido

ELEVAÇÃO 1:500

SEÇÃO 1:300

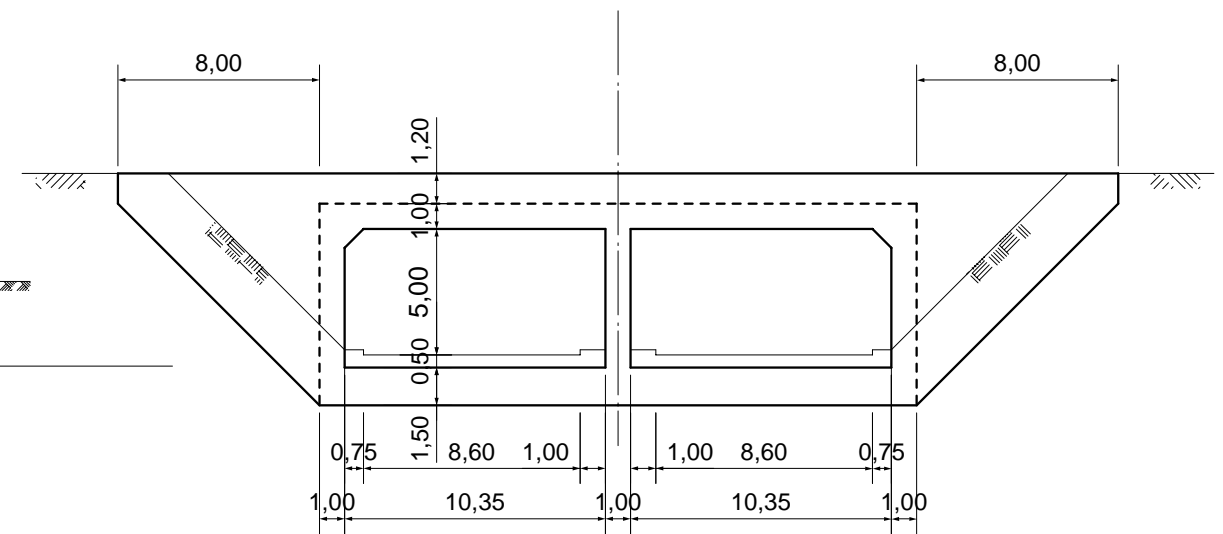
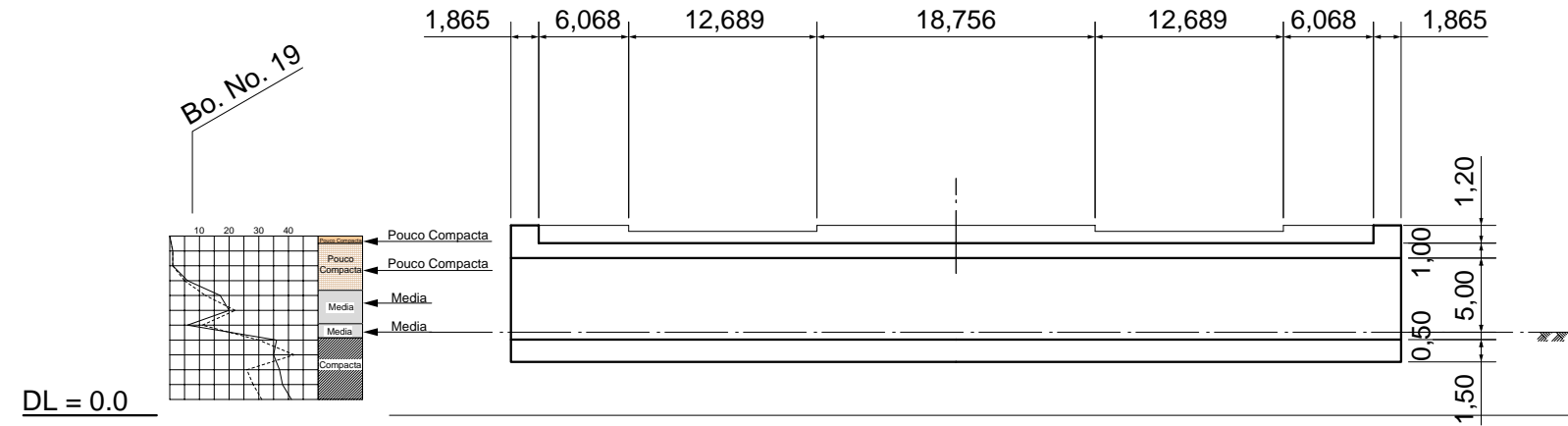

PLANTA 1:500

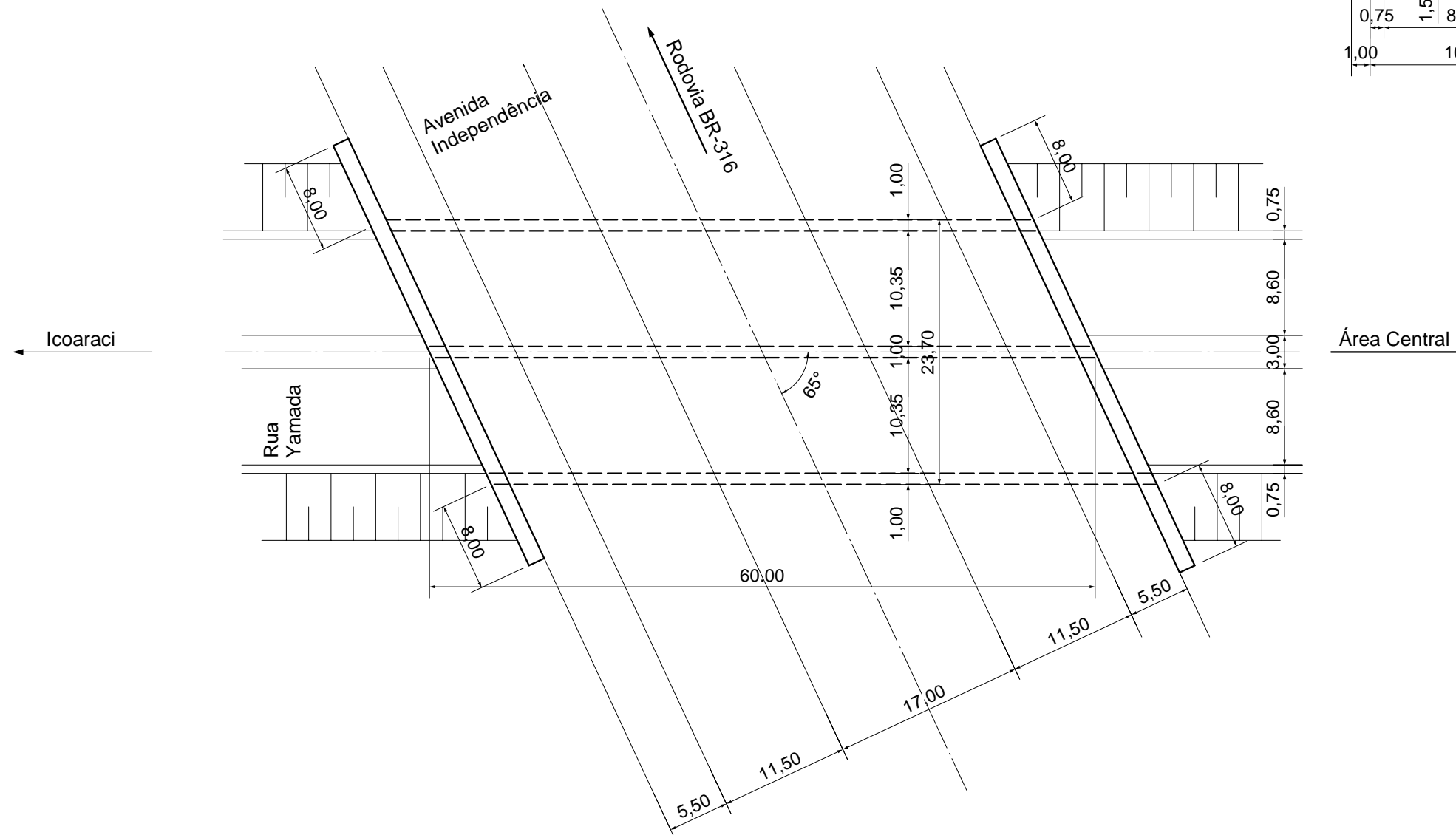

Desvio Alternativo

(Interseção Avenida Independência x Rodovia Augusto Montenegro)

MAPA DE LOCALIZAÇÃO 1 : 3.000

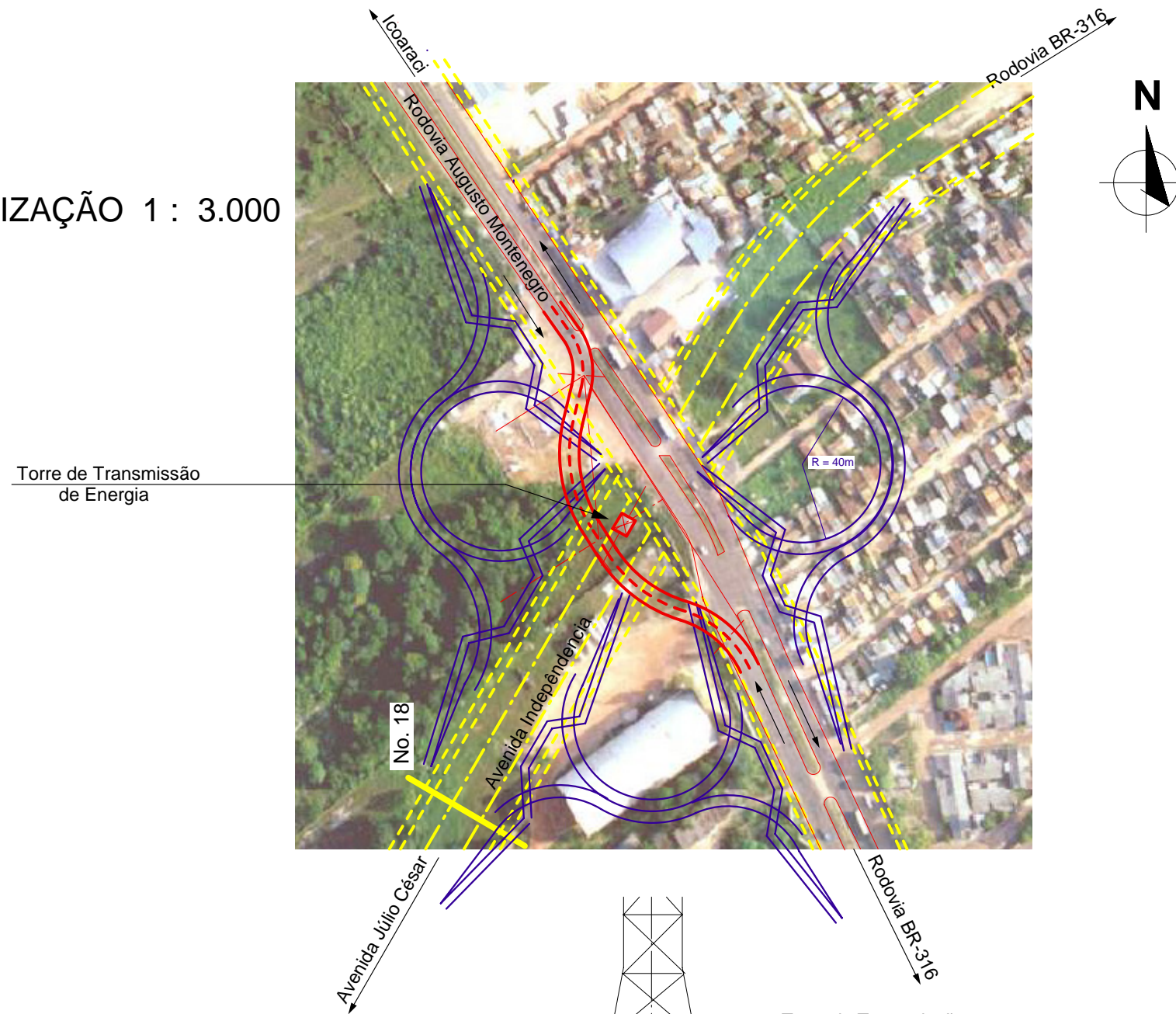

SEÇÃO 1 : 200

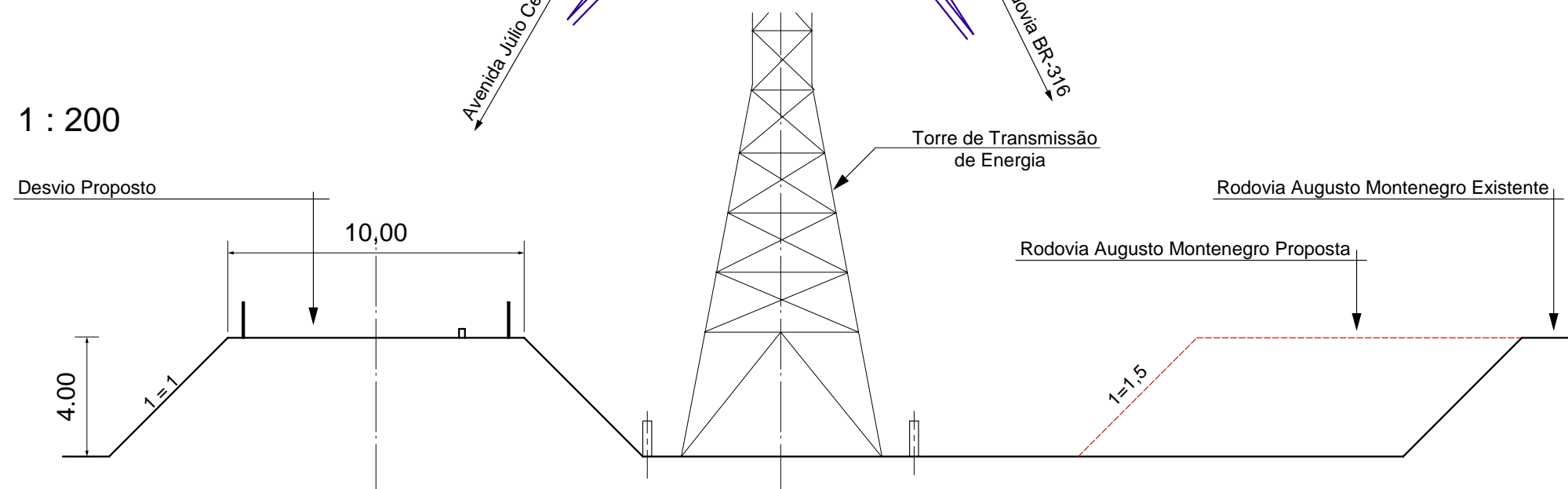

Parte III. Projeto de Faixa Prioritária para Ônibus

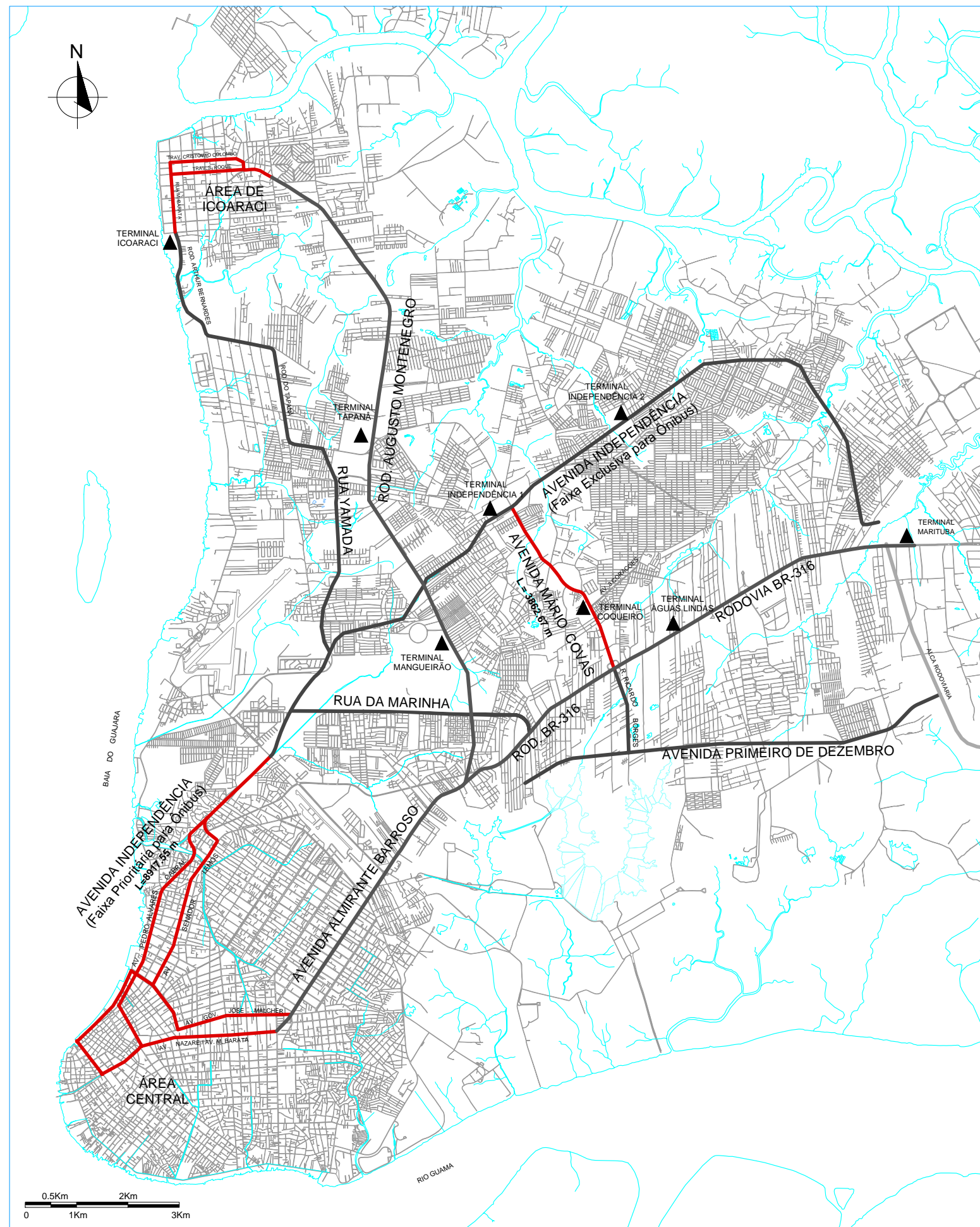

Legenda:

- ▲ Terminal de Integração
- Faixa Prioritária para Ônibus
- Outros Projetos