

5. Visual Manual for Implementing Village Hydro

- 1) How to Construct on Self-help Basis?
- 2) Demand Estimate and Planning
- 3) Design of Turbines and Transmission Lines
- 4) Design and Construction of Waterways
- 5) Fund and Guarantee



Diesel lamp is used because of no kerosen in market

Visual Manual for Village Hydro



Construction on Self-Help: Waterways - Power Canal



Construction on Self-Help: Waterways - Penstock (Pressure Pipe)



Construction on Self-Help: Erection of Supporting Poles



Construction on Self-Help: Transmission Lines



Crossflow Turbines



Electrification for Improving Village Life and Education

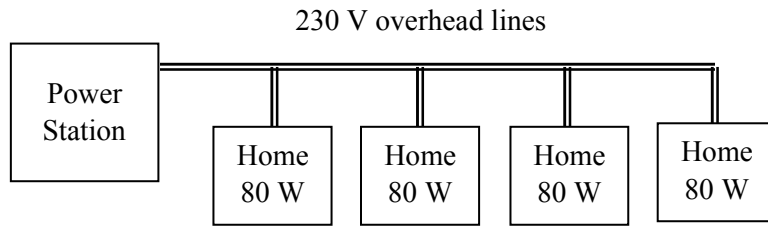

Typical Village Scheme with Power Station Nearby the Village

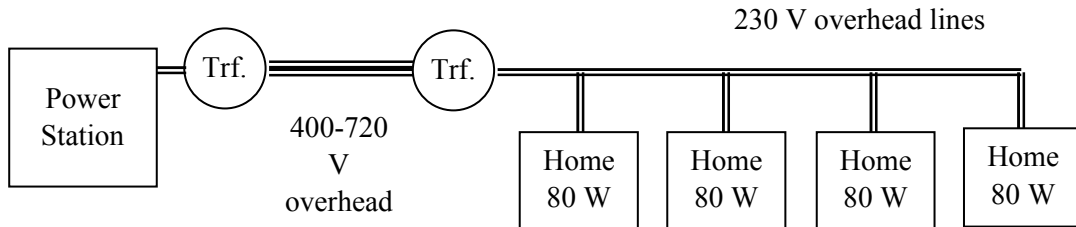

Step-up Transformer

Village Scheme with Power Station at Distant Location

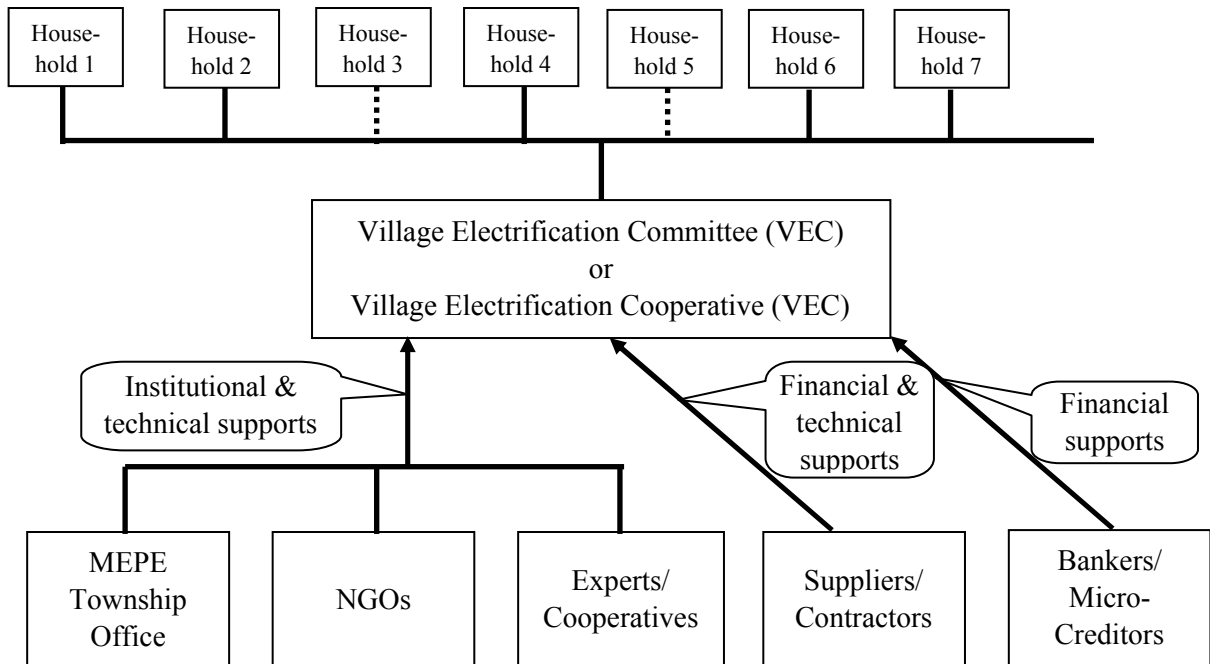

Supporters of Village Schemes

Type and Organization for Village Electrification

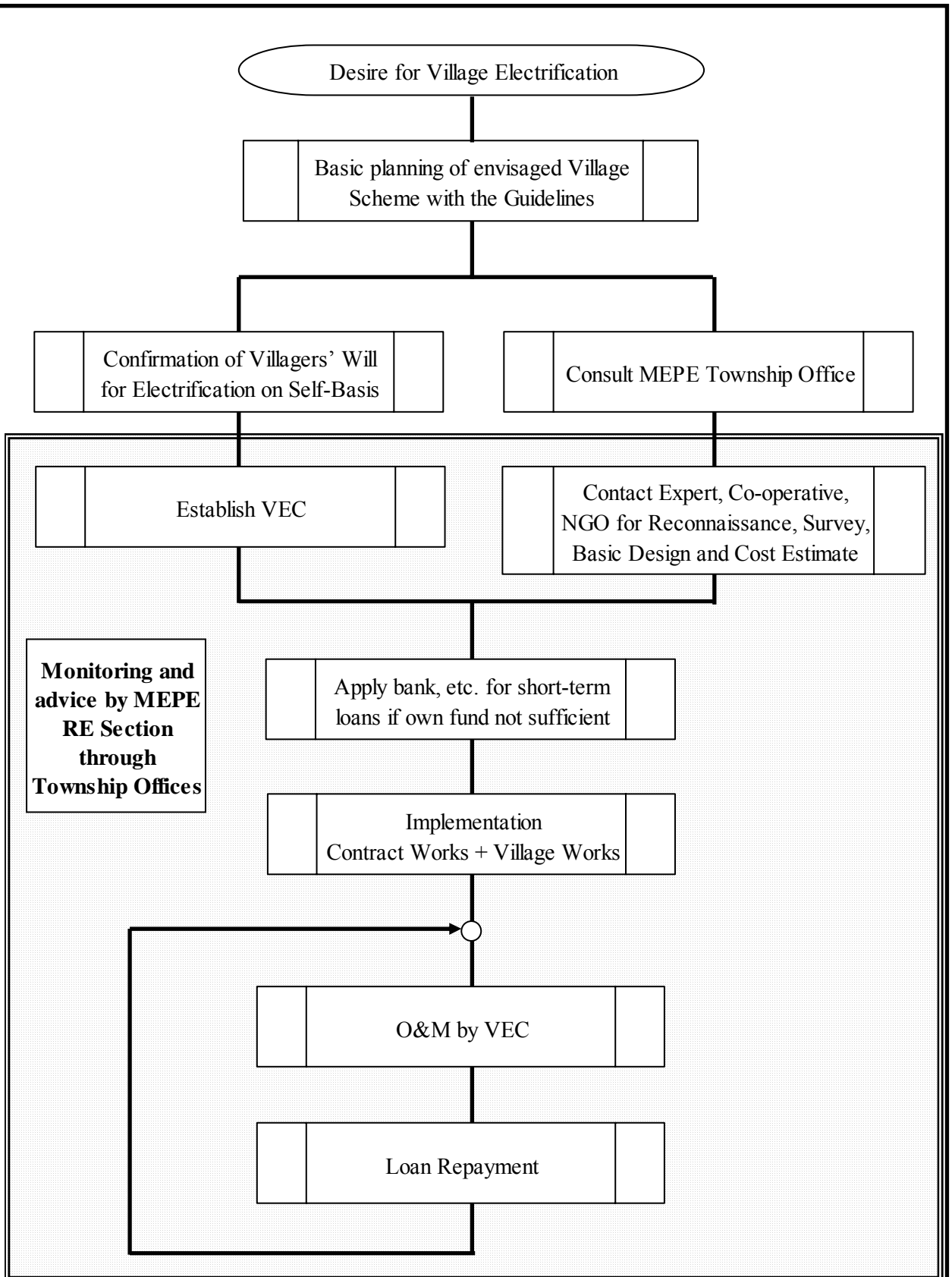

Typical Procedure for Implementing Village Scheme

Users	Share or nos. per household or village	Lighting	TV	Fan/ Heater	Unit Demand	Remarks
Domestic						
Type A Household with battery lighting	20% of total households	-	-	-	0	Charge battery at commercial BCS
Type B Household	60% of total households	20W x 2			40	
Type C Household	20% of total households	20W x 3	200W x 1		260	
Type D Shops/ restaurants	1 per 100 households	40W x 5	200W x 1	200 W x 1	600	
Public						
Primary School	1 per 100 households	40W x 15	200W x 1	200 W x 1	1,000	
Monastery/Community Hall	1 per 100 households	40W x 15		200 W x 2	1,000	
Clinic	1 per village > 100 households	40W x 5		200 W x 2	600	
Streetlights	4 households per street-light	40W x 1			40	per light. 20 W lights may also be used.
Business						
Battery Charging Station (BCS)	-	-	-	-	-	BCS on commercial basis may be operated with own generator.
Rice-mill, etc.	-	-	-	-	-	- ditto -



Estimate of Unit Demand and Number of Consumers in Village

Consumer category

Consumer Category	Domestic				Public			
	Type A	Type B	Type C	Type D	Primary School	Monastery/Community Hall	Clinic	Street-lights
Share or nos. per household or village	20% of total households	60% of total households	20% of total households	1 per 100 households	1 per 100 households	1 per 100 households	1 per village > 100 households	4 street-light
Unit Demand	0W	40W	260W	600W	1,000W	1,000W	600W	40W

Assumed number of consumers

Village Size (households)	Number of Consumers by Category								Total Number of Consumers
	Type A	Type B	Type C	Type D	Primary School	Monastery/Community Hall	Clinic	Street-lights	
400	80	240	80	4	4	4	1	100	433
350	70	210	70	3	3	3	1	87	377
300	60	180	60	3	3	3	1	75	325
250	50	150	50	2	2	2	1	62	269
200	40	120	40	2	2	2	1	50	217
150	30	90	30	1	1	1	1	37	161
100	20	60	20	1	1	1	1	25	109
50	10	30	10	0	0	0	0	12	52
20	4	12	4	0	0	0	0	5	21

Assumed demand

Village Size (households)	Demand by Consumer Category in kW								Total Demand Pd kW
	Type A	Type B	Type C	Type D	Primary School	Monastery/Community Hall	Clinic	Street-lights	
400	0.00	9.60	20.80	2.40	4.00	4.00	0.60	4.00	45.40
350	0.00	8.40	18.20	1.80	3.00	3.00	0.60	3.48	38.48
300	0.00	7.20	15.60	1.80	3.00	3.00	0.60	3.00	34.20
250	0.00	6.00	13.00	1.20	2.00	2.00	0.60	2.48	27.28
200	0.00	4.80	10.40	1.20	2.00	2.00	0.60	2.00	23.00
150	0.00	3.60	7.80	0.60	1.00	1.00	0.60	1.48	16.08
100	0.00	2.40	5.20	0.60	1.00	1.00	0.60	1.00	11.80
50	0.00	1.20	2.60	0.00	0.00	0.00	0.00	0.48	4.28
20	0.00	0.48	1.04	0.00	0.00	0.00	0.00	0.20	1.72

Selection of generator capacity

Village Size	Total Demand Pd	Required Generator Output Pr = 1.3 Pd	Selected Generator Capacity Pg
households	kW	kW	kW
400	45.40	59.02	60
350	38.48	50.02	55
300	34.20	44.46	45
250	27.28	35.46	40
200	23.00	29.90	30
150	16.08	20.90	25
100	11.80	15.34	20
50	4.28	5.56	10
20	1.72	2.24	4

Estimate of Village Demand and Required Generator Capacity

Required Discharge by Available Head

(Unit: m³/s)

Village Size households	Selected Generator Capacity Pg kW	Required Theoretical Potential kW	Required Discharge (m ³ /s) by Available Head (m)						
			30	20	15	10	7	5	3
400	60.00	105.00	0.36	0.54	0.71	1.07	1.53	2.14	3.57
350	55.00	96.25	0.33	0.49	0.65	0.98	1.40	1.96	3.27
300	45.00	78.75	0.27	0.40	0.54	0.80	1.15	1.61	2.68
250	40.00	70.00	0.24	0.36	0.48	0.71	1.02	1.43	2.38
200	30.00	52.50	0.18	0.27	0.36	0.54	0.77	1.07	1.79
150	25.00	43.75	0.15	0.22	0.30	0.45	0.64	0.89	1.49
100	20.00	35.00	0.12	0.18	0.24	0.36	0.51	0.71	1.19
50	10.00	17.50	0.06	0.09	0.12	0.18	0.26	0.36	0.60
20	4.00	7.00	0.02	0.04	0.05	0.07	0.10	0.14	0.24

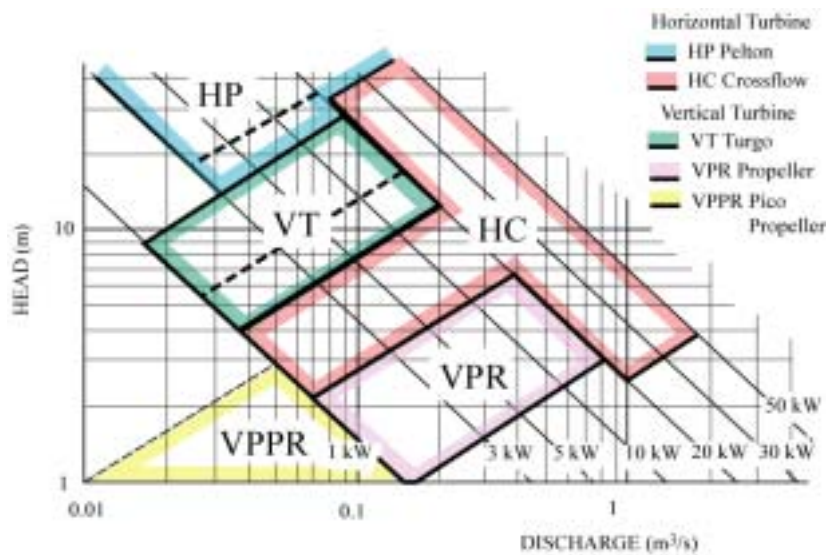

Application Range of Turbine Type for Low Head Micro Hydro

Village size	Power output	30 m	20 m	15 m	10 m	7 m	5 m	3 m
400	60	Crossflow turbine	Crossflow turbine	Crossflow turbine	Crossflow turbine	Crossflow turbine	Crossflow turbine	Over-shot type
350	55							
300	45							
250	40							
200	30	Undershot type	Undershot type	Undershot type	Undershot type	Undershot type	Undershot type	Undershot type
150	25							
100	20							
50	10							
20	4	Undershot type	Undershot type	Undershot type	Undershot type	Undershot type	Undershot type	Undershot type

Recommended Type of Crossflow Turbines for Village Hydro

Required Water and Recommended Turbine Type

Dimension of Waterway by Available Head

(I = 1/1500, n= 0.018)

Village Size	Selected Generator Capacity	Required Theoretical Potential		Available Head (m)						
				30	20	15	10	7	5	3
households	kW	kW								
400	60.00	105.00	Q (m ³ /s)	0.36	0.54	0.71	1.07	1.53	2.14	3.57
			B _{PC} (m)	1.09	1.27	1.41	1.64	1.88	2.13	2.58
			H _{PC} (m)	0.55	0.64	0.71	0.82	0.94	1.07	1.29
			A _{HT} (m ²)	1.80	2.70	3.55	5.35	7.65	10.70	17.85
			D _{PS} (m)	0.55	0.69	0.81	1.03	1.26	1.52	2.04
350	55.00	96.25	Q (m ³ /s)	0.33	0.49	0.65	0.98	1.40	1.96	3.27
			B _{PC} (m)	1.06	1.23	1.36	1.59	1.82	2.06	2.50
			H _{PC} (m)	0.53	0.62	0.68	0.80	0.91	1.03	1.25
			A _{HT} (m ²)	1.65	4.00	3.00	2.00	1.40	1.00	0.60
			D _{PS} (m)	0.53	0.66	0.78	0.99	1.21	1.47	1.97
300	45.00	78.75	Q (m ³ /s)	0.27	0.40	0.54	0.80	1.15	1.61	2.68
			B _{PC} (m)	0.98	1.14	1.27	1.48	1.69	1.91	2.32
			H _{PC} (m)	0.49	0.57	0.64	0.74	0.85	0.96	1.16
			A _{HT} (m ²)	1.35	2.00	2.70	4.00	5.75	8.05	13.40
			D _{PS} (m)	0.48	0.61	0.72	0.91	1.11	1.35	1.80
250	40.00	70.00	Q (m ³ /s)	0.24	0.36	0.48	0.71	1.02	1.43	2.38
			B _{PC} (m)	0.94	1.10	1.22	1.41	1.61	1.83	2.20
			H _{PC} (m)	0.47	0.55	0.61	0.71	0.81	0.92	1.10
			A _{HT} (m ²)	1.20	1.80	2.40	3.55	5.10	7.15	11.90
			D _{PS} (m)	0.46	0.58	0.68	0.86	1.06	1.28	1.71
200	30.00	52.50	Q (m ³ /s)	0.18	0.27	0.36	0.54	0.77	1.07	1.79
			B _{PC} (m)	0.84	0.98	1.10	1.27	1.45	1.64	1.99
			H _{PC} (m)	0.42	0.49	0.55	0.64	0.73	0.82	1.00
			A _{HT} (m ²)	0.90	1.35	1.80	2.70	3.85	5.35	8.95
			D _{PS} (m)	0.41	0.51	0.60	0.76	0.93	1.13	1.52
150	25.00	43.75	Q (m ³ /s)	0.15	0.22	0.30	0.45	0.64	0.89	1.49
			B _{PC} (m)	0.79	0.91	1.02	1.19	1.36	1.53	1.86
			H _{PC} (m)	0.40	0.46	0.51	0.60	0.68	0.77	0.93
			A _{HT} (m ²)	0.75	1.10	1.50	2.25	3.20	4.45	7.45
			D _{PS} (m)	0.38	0.47	0.56	0.70	0.86	1.05	1.40
100	20.00	35.00	Q (m ³ /s)	0.12	0.18	0.24	0.36	0.51	0.71	1.19
			B _{PC} (m)	0.72	0.84	0.94	1.09	1.25	1.41	1.71
			H _{PC} (m)	0.36	0.42	0.47	0.55	0.63	0.71	0.86
			A _{HT} (m ²)	0.60	0.90	1.20	1.80	2.55	3.55	5.95
			D _{PS} (m)	0.34	0.43	0.51	0.64	0.78	0.95	1.27
50	10.00	17.50	Q (m ³ /s)	0.06	0.09	0.12	0.18	0.26	0.36	0.60
			B _{PC} (m)	0.56	0.65	0.72	0.84	0.97	1.09	1.32
			H _{PC} (m)	0.28	0.33	0.36	0.42	0.49	0.55	0.66
			A _{HT} (m ²)	0.30	0.45	0.60	0.90	1.30	1.80	3.00
			D _{PS} (m)	0.25	0.32	0.38	0.48	0.58	0.71	0.95
20	4.00	7.00	Q (m ³ /s)	0.02	0.04	0.05	0.07	0.10	0.14	0.24
			B _{PC} (m)	0.38	0.48	0.52	0.59	0.68	0.77	0.94
			H _{PC} (m)	0.19	0.24	0.26	0.30	0.34	0.39	0.47
			A _{HT} (m ²)	0.10	0.20	0.25	0.35	0.50	0.70	1.20
			D _{PS} (m)	0.17	0.22	0.25	0.32	0.39	0.48	0.64

Note 1: Refer to Part 4-3 Design Manual-Village Hydros for details.

Note 2: The dimension above are for reference purpose only. The actual dimension shall be determined with reference to site conditions (power canal and head tank) and workability of excavation and concreting as well as to market availability of penstock pipes.

Standard Size of Waterways

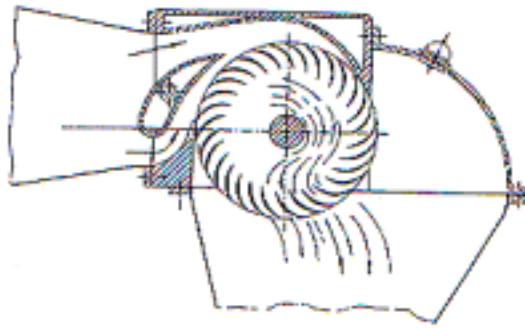

Flow of Crossflow-type Turbine

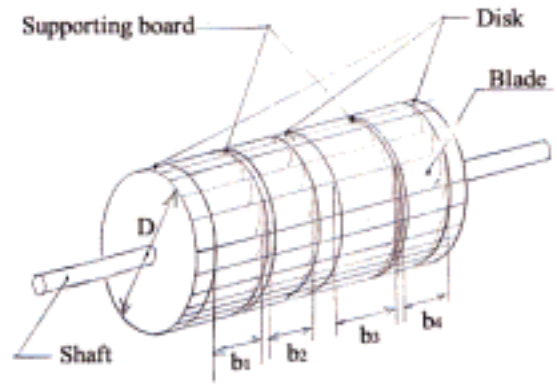

Runner of Crossflow-type Turbine

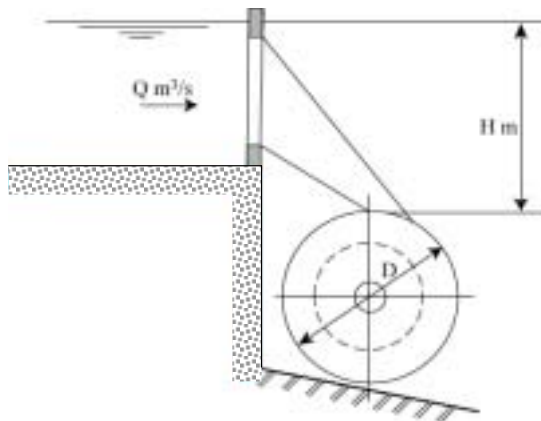

Application of Overshot Crossflow Turbine to Drop-Structures

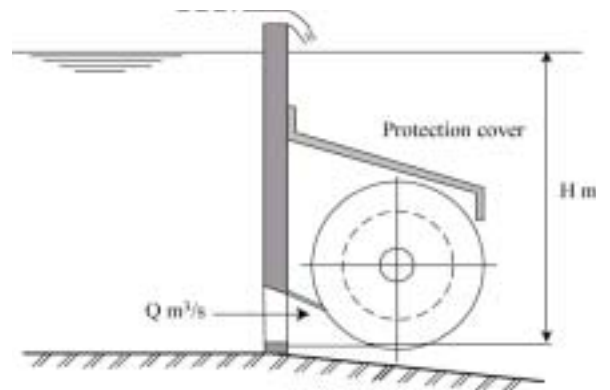

Example of Application of Undershot Crossflow to Canal

Crossflow-type Turbines Suitable for Village Hydro

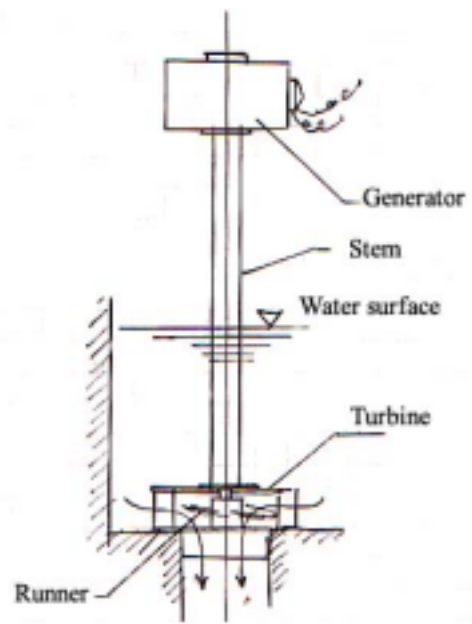

Village channel for Pico hydro



Pico machines on shop



Typical installation



Pico Hydro

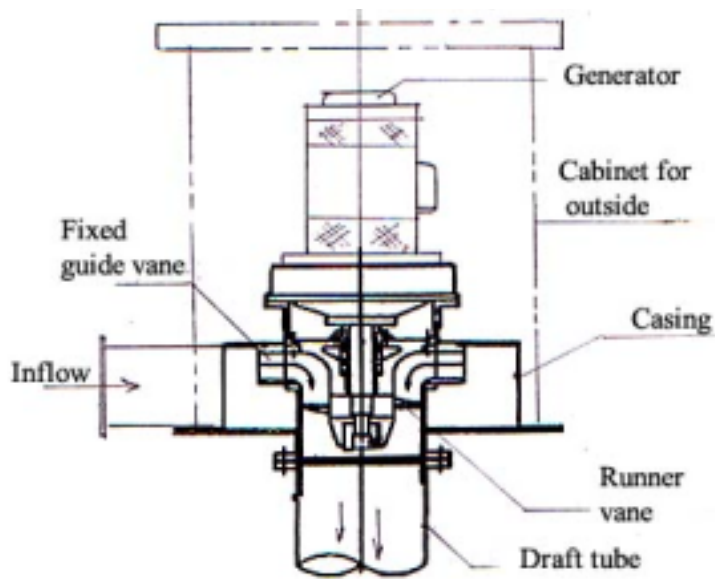

Package type turbine-generator



Propeller Turbines for Micro Hydros

Basic Dimensions of Crossflow-type Runner for VillageHydro

Village size	Generator output		Turbine Dimension by Available Head (m)						
			30	20	15	10	7	5	3
Households	kW								
400	60	D (mm)	300	300	450	700	700	1000	1000
		N (min ⁻¹)	750	610	350	185	154	90	70
		B (m)	0.35	0.66	0.66	0.78	1.33	1.56	3.40
		d _s (mmφ)	70	70	85	125	130	160	170
350	55	D (mm)	300	300	450	450	700	1000	1000
		N (min ⁻¹)	750	610	350	290	154	90	70
		B (m)	0.330	0.600	0.600	1.100	1.230	1.400	3.100
		d _s (mmφ)	60	65	65	100	120	130	155
300	45	D (mm)	300	300	450	450	700	700	1000
		N (min ⁻¹)	750	610	350	290	154	130	70
		B (m)	0.270	0.500	1.000	0.930	1.000	1.700	2.540
		d _s (mmφ)	60	65	65	100	120	130	155
250	40	D (mm)	300	300	300	450	700	700	1000
		N (min ⁻¹)	750	610	350	290	154	130	70
		B (m)	0.230	0.430	0.660	0.820	0.900	1.500	2.260
		d _s (mmφ)	60	60	65	95	115	125	150
200	30	D (mm)	300	300	300	450	450	700	1000
		N (min ⁻¹)	750	610	530	290	154	130	70
		B (m)	0.17	0.33	0.50	0.61	1.00	1.10	1.70
		d _s (mmφ)	50	55	60	85	85	110	140
150	25	D (mm)	200	300	300	450	450	700	700
		N (min ⁻¹)	1120	610	530	290	240	200	100
		B (m)	0.22	0.20	0.41	0.50	0.87	0.90	2.00
		d _s (mmφ)	45	50	55	80	80	100	120
100	20	D (mm)	200	300	300	300	450	450	700
		N (min ⁻¹)	120	610	530	430	240	200	100
		B (m)	0.18	0.16	0.33	0.62	0.70	1.16	1.6
		d _s (mmφ)	40	50	55	60	74	85	105
50	10	D (mm)	200	200	300	300	300	450	450
		N (min ⁻¹)	1120	920	530	430	360	200	160
		B (m)	0.10	0.16	0.16	0.33	0.50	0.60	1.20
		d _s (mmφ)	30	40	40	45	45	65	75
20	4	D (mm)	200	200	200	300	300	300	450
		N (min ⁻¹)	1120	920	790	430	360	300	160
		B (m)	0.05	0.07	0.10	0.10	0.18	0.30	0.52
		d _s (mmφ)	25	30	30	35	35	45	55

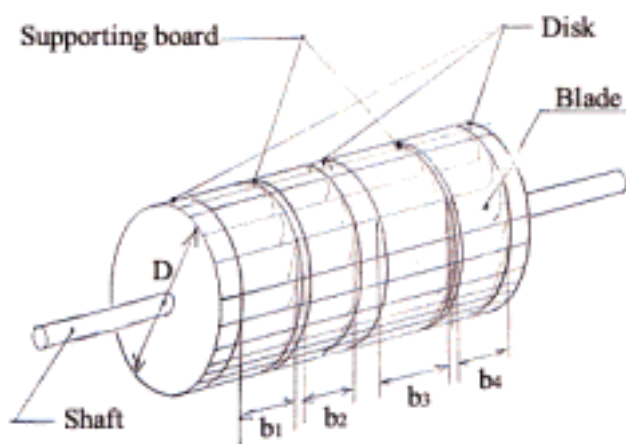

D: diameter of runner
N: revolution speed per minute
B: total effective breadth of runner
ds: diameter of main shaft

Note: Color groups turbines by diameter.

Basic Dimensions of Crossflow-type Runner for VillageHydro



MEPE Workshop



Making shaft for Crossflow turbine



Seimpann Cooperatives in Mandalay



U Khun Kyaw, Taung Gyi



U Chit Hla and Sons, Aye Thar Yar



Hydro Workshops in Myanmar

ACSR Wire Size and Max. Distance in m for Single Phase Transmission at 400 V and 230 V

Village size	Generator output	Transmission distance at transmission voltage 400 V m, () shows at 230 V						
		Size of ACSR wire (mm ²)						
households	kW	16	25	35	50	70	90	100
400	60	50 (25)	120 (40)	170 (55)	240 (80)	340 (110)	430 (140)	480 (160)
350	55	28 (28)	130 (43)	180 (60)	260 (85)	370 (120)	470 (150)	520 (170)
300	45	100 (33)	160 (53)	220 (74)	320 (105)	450 (150)	570 (190)	640 (210)
250	40	115 (38)	180 (60)	250 (83)	360 (120)	500 (167)	540 (214)	720 (240)
200	30	150 (50)	240 (80)	330 (110)	480 (160)	670 (220)	860 (285)	950 (320)
150	25	180 (60)	290 (95)	400 (130)	570 (190)	800 (270)	1,030 (340)	1,150 (380)
100	20	230 (75)	360 (120)	500 (170)	720 (240)	1,000 (330)	1,290 (430)	1,440 (480)
50	10	460 (150)	720 (240)	1,000 (330)	1,440 (480)	2,010 (670)	2,580 (860)	2,870 (950)
20	4	1,150 (380)	1,800 (600)	2,500 (830)	3,600 (1200)	5,000 (1700)	6,460 (2100)	7,180 (2400)

ACSR Wire Size and Max. Distance in m for Single Phase Transmission at 600 V and 230 V

Village size	Generator output	Transmission distance at transmission voltage 600 V m, () shows at 230 V						
		Size of ACSR wire (mm ²)						
households	kW	16	25	35	50	70	90	100
400	60	170 (25)	270 (40)	380 (55)	540 (80)	750 (110)	970 (140)	1,000 (160)
350	55	190 (28)	290 (43)	410 (60)	590 (85)	820 (120)	1,060 (150)	1,180 (170)
300	45	230 (33)	360 (53)	500 (74)	720 (105)	1,000 (150)	1,290 (190)	1,430 (210)
250	40	260 (38)	400 (60)	570 (83)	900 (120)	1,130 (167)	1,450 (214)	1,600 (240)
200	30	340 (50)	540 (80)	750 (110)	1,070 (160)	1,500 (220)	1,940 (285)	2,150 (320)
150	25	410 (60)	650 (95)	900 (130)	1,290 (190)	1,800 (270)	2,300 (340)	2,580 (380)
100	20	500 (75)	800 (120)	1,130 (170)	1,610 (240)	2,260 (330)	2,900 (430)	3,200 (480)
50	10	1,000 (150)	1,620 (240)	2,260 (330)	3,230 (480)	4,500 (670)	5,800 (860)	6,460 (950)
20	4	2,600 (380)	4,000 (600)	5,650 (830)	8,070 (1200)	11,300 (1700)	14,500 (2100)	16,150 (2400)



Selection of Conductor Size by Transmitting Power, Voltage, and Distance

ACSR Wire Size and Max. Distance in m for Three Phase Transmission at 600 V and 230 V

Village size	Generator output	Transmission distance at transmission voltage 600 V m, () shows at 230 V						
		Size of ACSR wire (mm ²)						
households	kW	16	25	35	50	70	90	100
400	60	600 (88)	900 (130)	1,300 (190)	1,900 (280)	2,600 (380)	3,350 (490)	3,700 (540)
350	55	650 (95)	1,000 (150)	1,400 (200)	2,000 (300)	2,800 (410)	3,650 (540)	4,050 (600)
300	45	80 (120)	1,250 (180)	1,700 (250)	2,500 (370)	3,500 (510)	4,450 (650)	5,000 (730)
250	40	900 (130)	1,400 (200)	2,000 (300)	2,800 (410)	3,900 (570)	5,000 (730)	5,600 (820)
200	30	1,200 (180)	1,800 (280)	2,600 (380)	3,700 (540)	5,200 (760)	6,700 (980)	7,450 (1100)
150	25	1,400 (200)	2,200 (320)	3,100 (460)	4,500 (660)	6,250 (920)	8,050 (1200)	8,900 (1300)
100	20	1,800 (260)	2,800 (410)	3,900 (570)	5,600 (820)	7,800 (1150)	10,000 (1470)	11,200 (1650)

ACSR Cost

Items	Unit	Size of ACSR (mm ²)						
		16	25	35	50	70	90	105
Weight per km	kg	62	97	140	196	280	836	891
Price per viss	Kyat	3,600	3,600	3,600	3,600	3,600	3,600	3,600
Price per kg	Kyat	2,250	2,250	2,250	2,250	2,250	2,250	2,250
Price per km	Kyat	139,500	218,250	315,000	441,000	630,000	1,881,000	2,004,750
Price per viss	\$	3.60	3.60	3.60	3.60	3.60	3.60	3.60
Price per kg	\$	2.25	2.25	2.25	2.25	2.25	2.25	2.25
Price per km	\$	140	218	315	441	630	1,881	2,005

Source: Market survey by JICA Study Team

Assumed exchange rate at US\$1.00 = Kyat 1,000 as of August 2003

1 Viss = 1.6 kg

Selection of Conductor Size by Transmitting Power, Voltage, and Distance, and Market Price Level



Sample of using existing structure
Existing stone weir is used as intake.



Sample of utilizing natural topography
Utilizing waterfalls for stable riverbed,



Sample of weir by sandbags



Sample of Intake Trashracks
Primary racks for flowing trees combined with secondary racks for tree leaves.



Wooden Hand-pull Gate
Just start opening. The wooden gate well functions. Tha Le Oo.

Examples of Intake Facilities

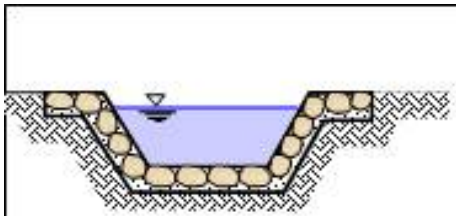

Stone Masonry Canal

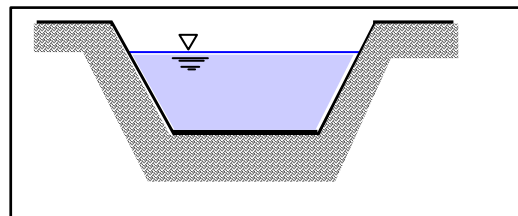

Earth Canal



Stone Masonry Canal, Sempai



Masonry Canal



Stone-pitched Canal, Hanpo



**Power Canal under Construction,
Tha Le Oo**



Earth Canal with Bypass

Examples of Waterway - Power Canal



Head Tank and Bamboo Trashrack



Head Tank with Trashracks



No spillway and side walls are not high enough to avoid water spilling



Head tank too small, no trashracks and floating debris can clog the penstock inlet



Stone masonry pond for villagers' amenity. It also functions as a head tank.



A sample of step spillway attached to the pond left.

Examples of Head Tanks and Spill Way



Penstock on Masonry Slopes
Penstock is placed on stone masonry to a adjust to site topography. Mine Pon



Penstock under Installation, Naung Bo



Anchor Block of Penstock



Penstock and Distribution Line

Examples of Waterways - Penstock (Pressure Pipe)

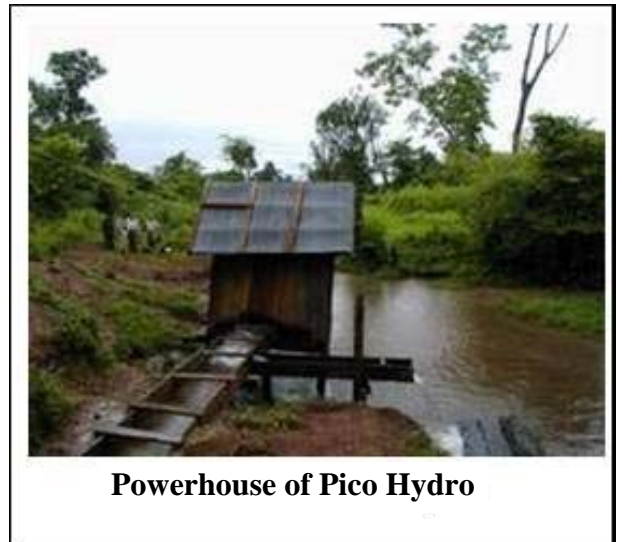

Powerhouse of Pico Hydro

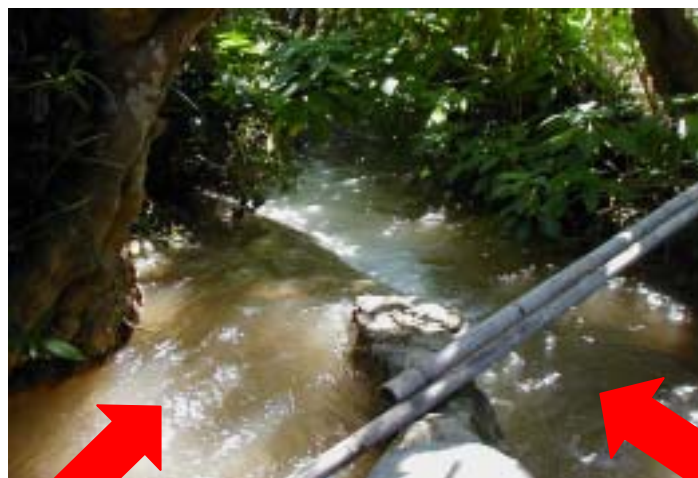

Tailrace

River

Tailrace water drops into river, a good sample to avoid flood effect

Examples of Powerhouses and Tailraces

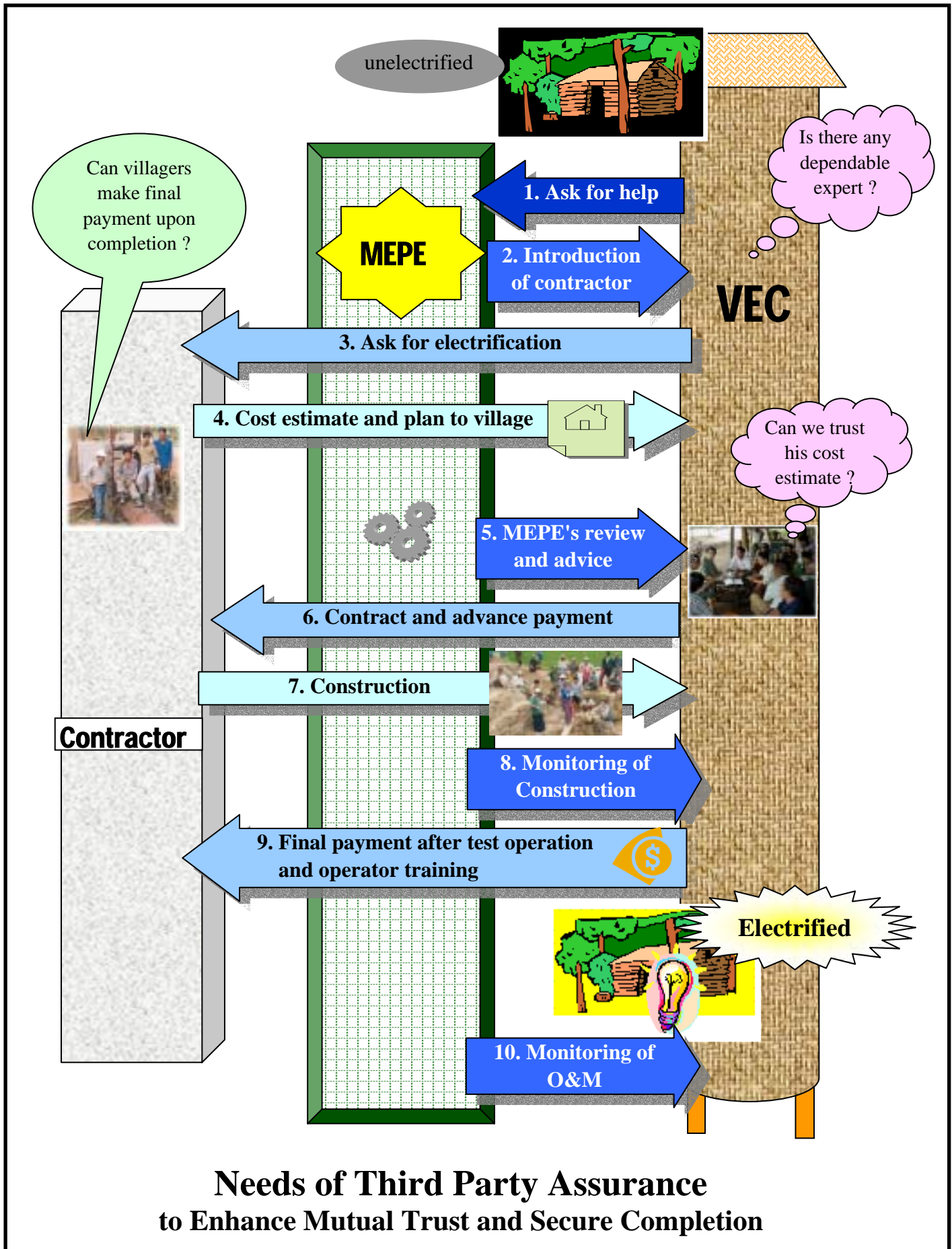

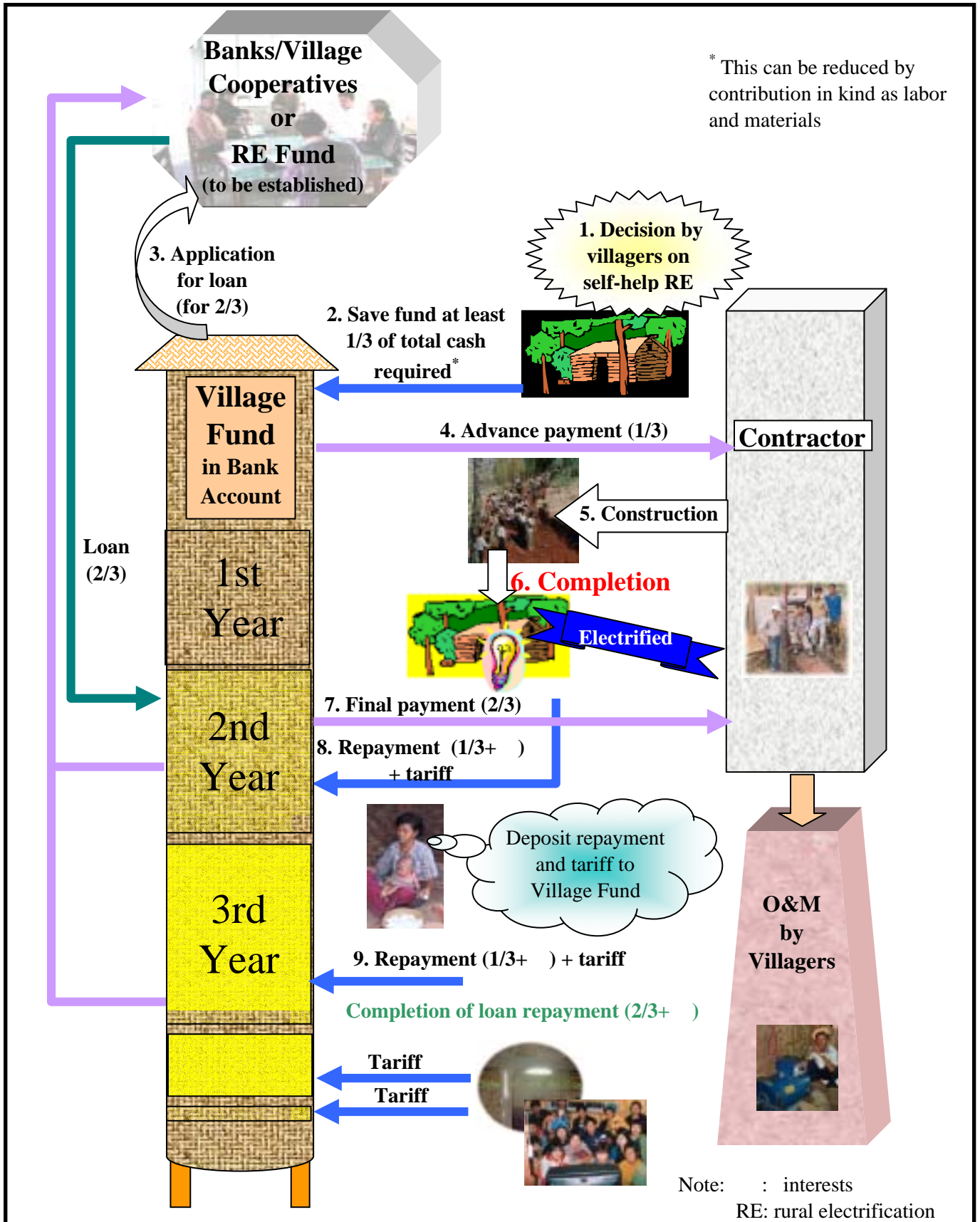

Save Fund for Electrification

1. Myanmar Agriculture Development Bank
2. Cooperative Societies/Banks
3. RE Fund (to be established)

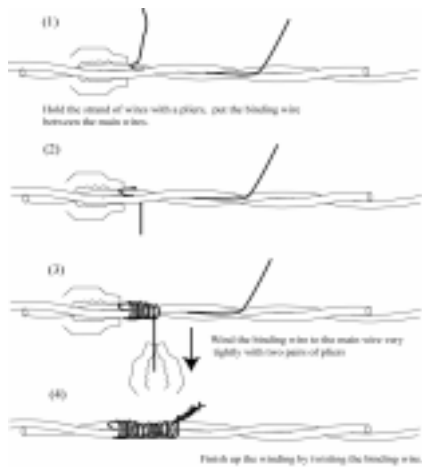

Seminar for Promoting Rural Electrification

Data Sheet for Basic Planning of Village Hydro (<50 kW)

No.	Item	Fill Line		Range	Advice
1	Name of Village				
2	Division / State				
3	Possibility of extension of distribution lines from Grid			L > 10 km	OK. Proceed with Village Hydro (< 50 kW)
				L < 10 km	Extension of distribution line is to be first studied.
4	Possibility of power supply by rehabilitation of existing hydros nearby			Yes	Rehabilitation is to be studied.
				No	OK. Proceed further below.
5	Road length to be constructed newly			L > 1 km	Check wire size and required costs before proceeding.
				L < 1 km	OK. Proceed further below.
6	Transmission line distance from site to target villages (km)			L > 1 km	Check work volume and required costs before proceeding.
				L < 1 km	OK. Proceed further below.
7	Households to be electrified			100 ~ 500	Installed capacity required : 10 kW-50 kW
				50 ~ 100	Installed capacity required : 5 kW-10 kW
				< 50	Installed capacity required : < 5 kW
8	List of public facilities	No.	Facility	Nos.	
		1			
		2			
		3			
		4			
		5			
		6			
9	Ability to pay (Kyat)				
10	Discharge in dry season (m ³ /s)			Q > 2.0m ³ /s	Possible, but special care for flooding, waterway, and turbine.
				2.0 > Q > 0.5 m ³ /s	OK but discharge partially used.
				Q < 0.5 m ³ /s	OK suitable for Village Hydro.
11	Date of discharge measurement			Jan. - May	OK
				Jun. - Dec.	Try again in Jan. to May.
12	Head available for power generation (m)			H > 30 m	Not recommendable. Special turbine design required.
				H < 30 m	Suitable for Village Hydro.
13	Distance from Intake to Powerhouse (km)			L > 500 m	Not recommendable, check alternative sites
				500 m > L > 200 m	OK but to check work volume and required costs.
				L < 200 m	OK suitable for Village Hydro.