

Figure 4.7
Distribution of the Daraitan Limestone Mass

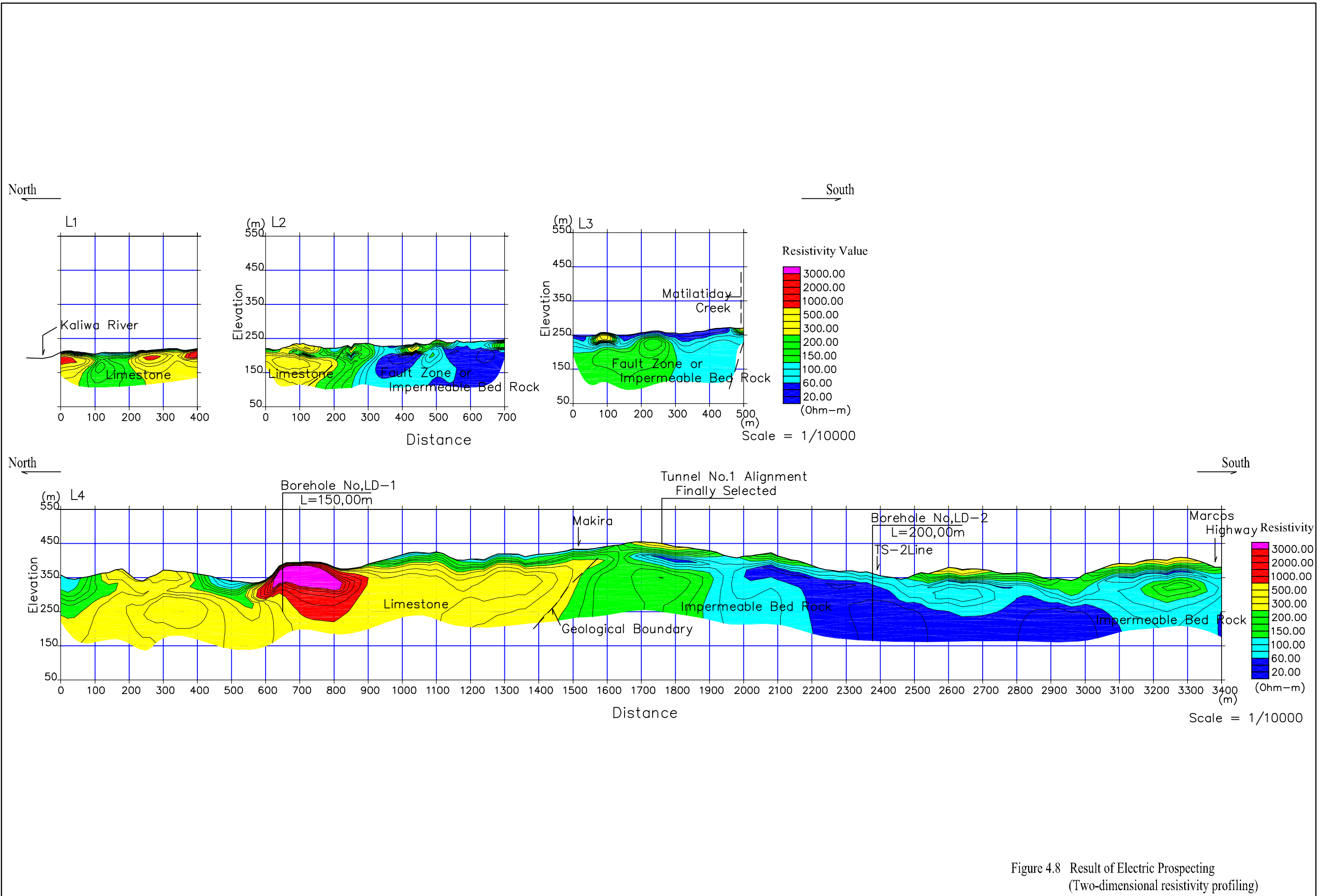

Figure 4.8 Result of Electric Prospecting (Two-dimensional resistivity profiling)

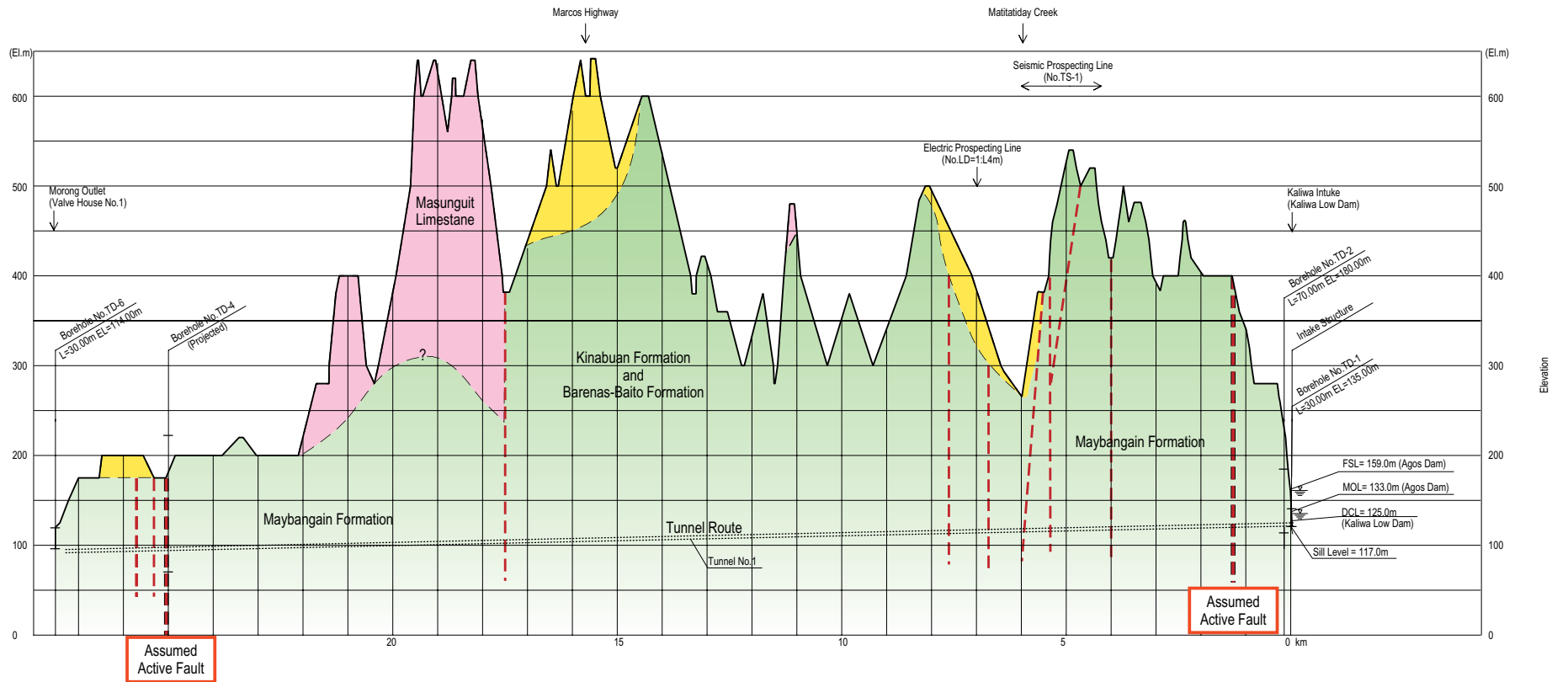
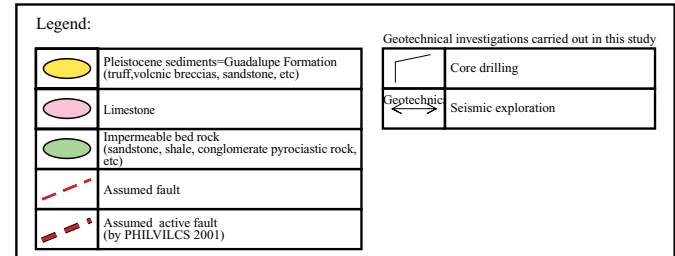
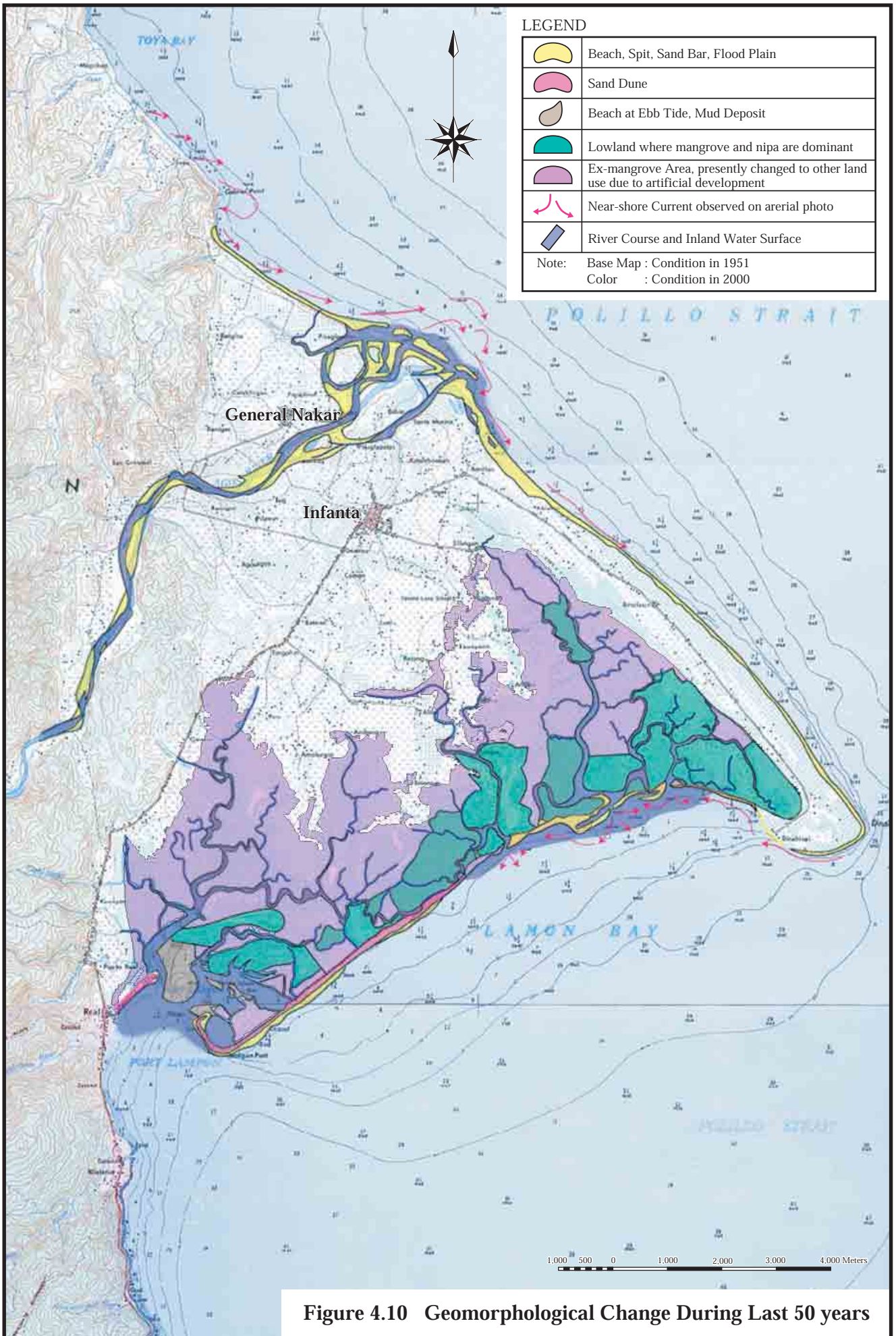

Figure 4.9 Profile of the Tunnel No.1



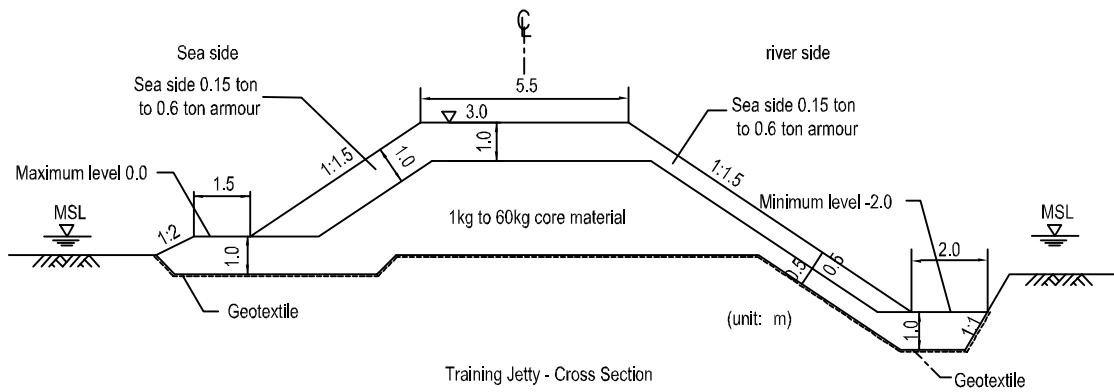
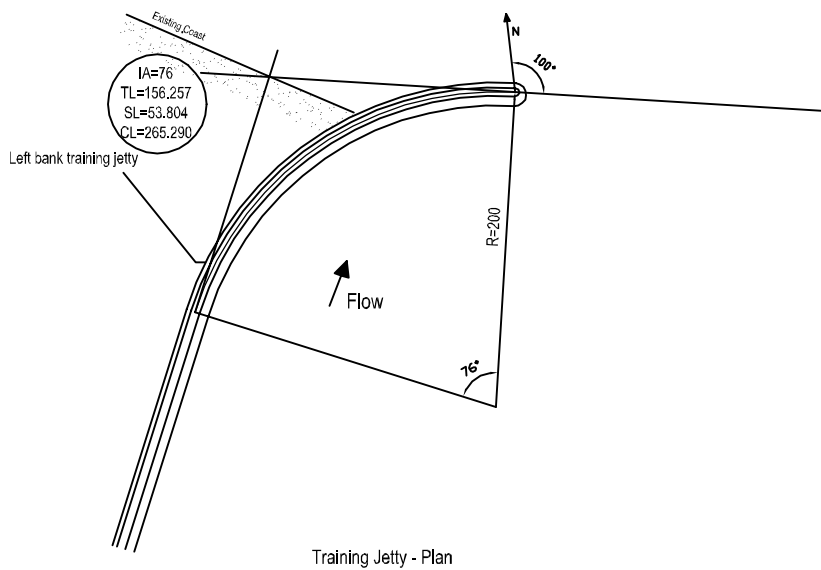
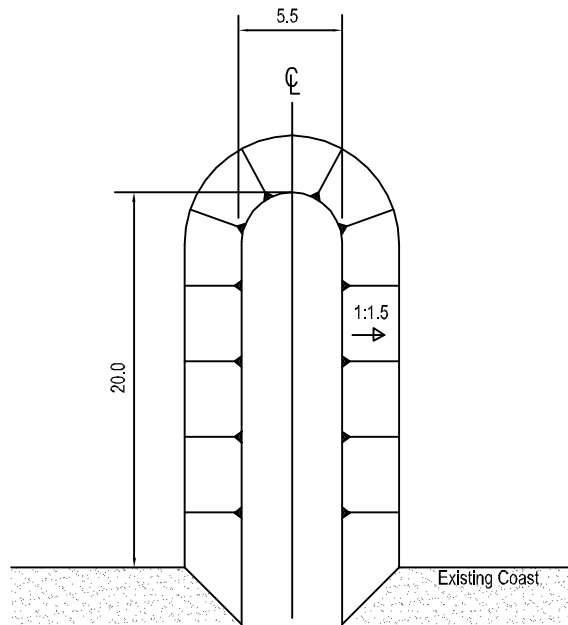
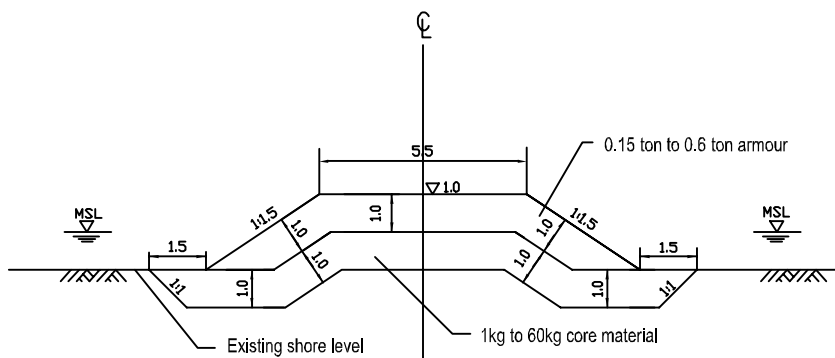

Figure 4.11 Training Jetty - Measures to Cope with Future Coastal Change



Jetty - Plan



Jetty - Cross Section

(unit: m)

Figure 4.12 Jetty - Measures to Cope with Future Change of Coastal Shoreline