

Ja Ela

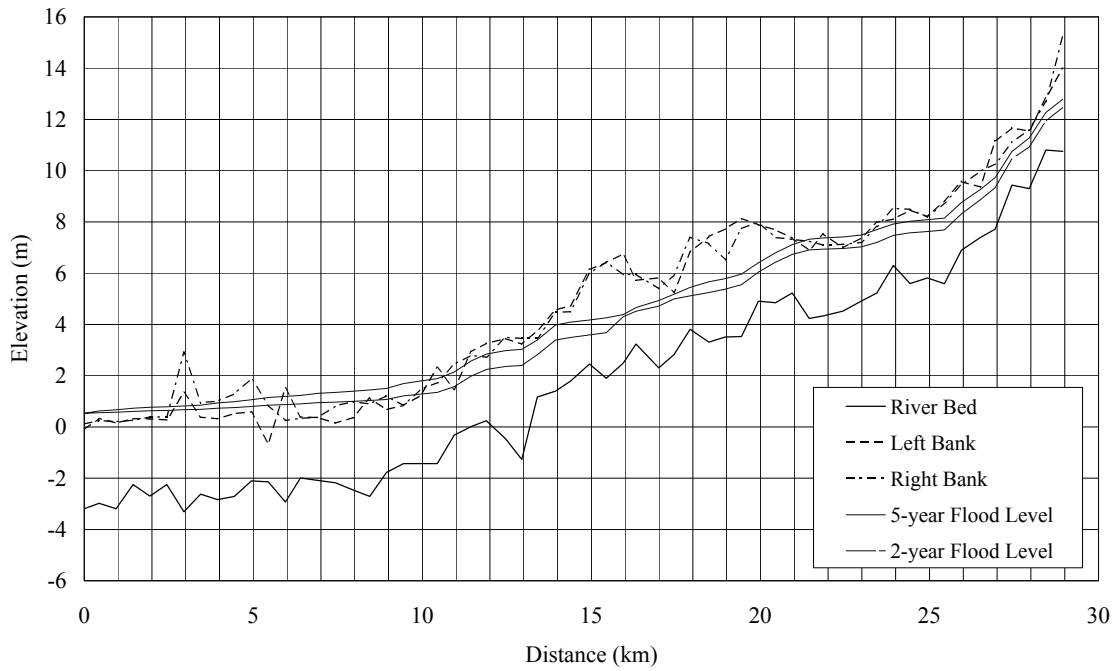

*The Study on Storm Water Drainage Plan
for the Colombo Metropolitan Region
in the Democratic Socialist Republic of Sri Lanka*
JAPAN INTERNATIONAL COOPERATION AGENCY

Figure 3.3.1
River Longitudinal Profile (1/2)
(Ja Ela)

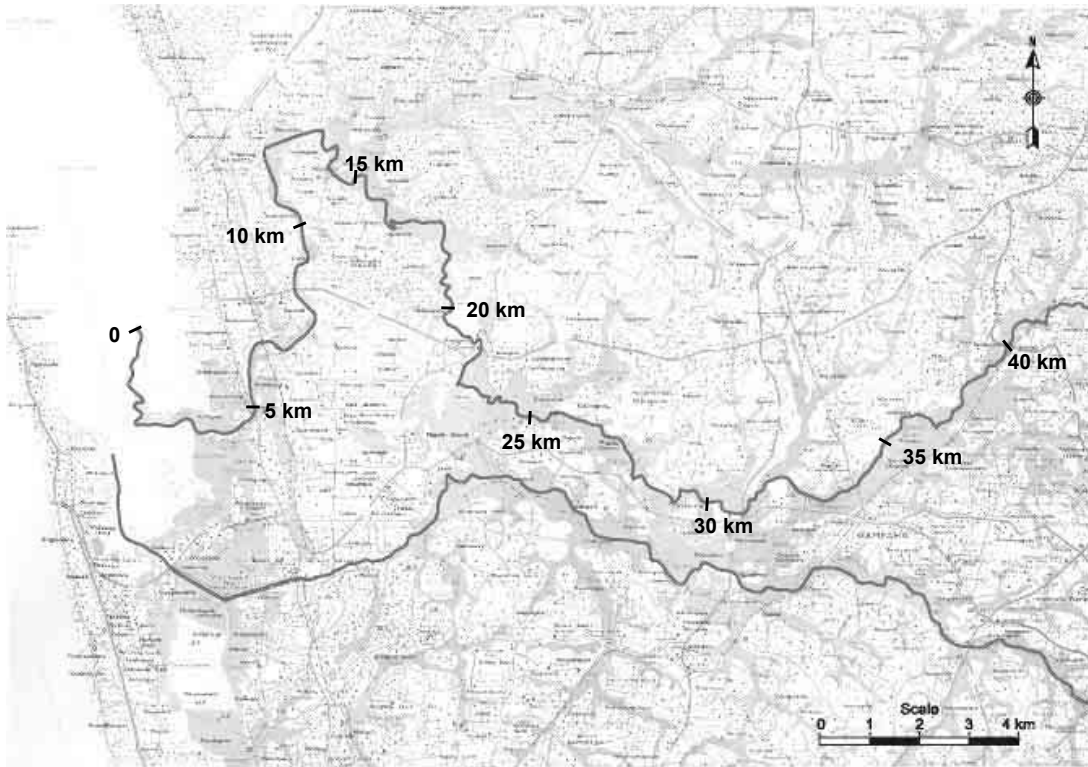

Dandugam Oya

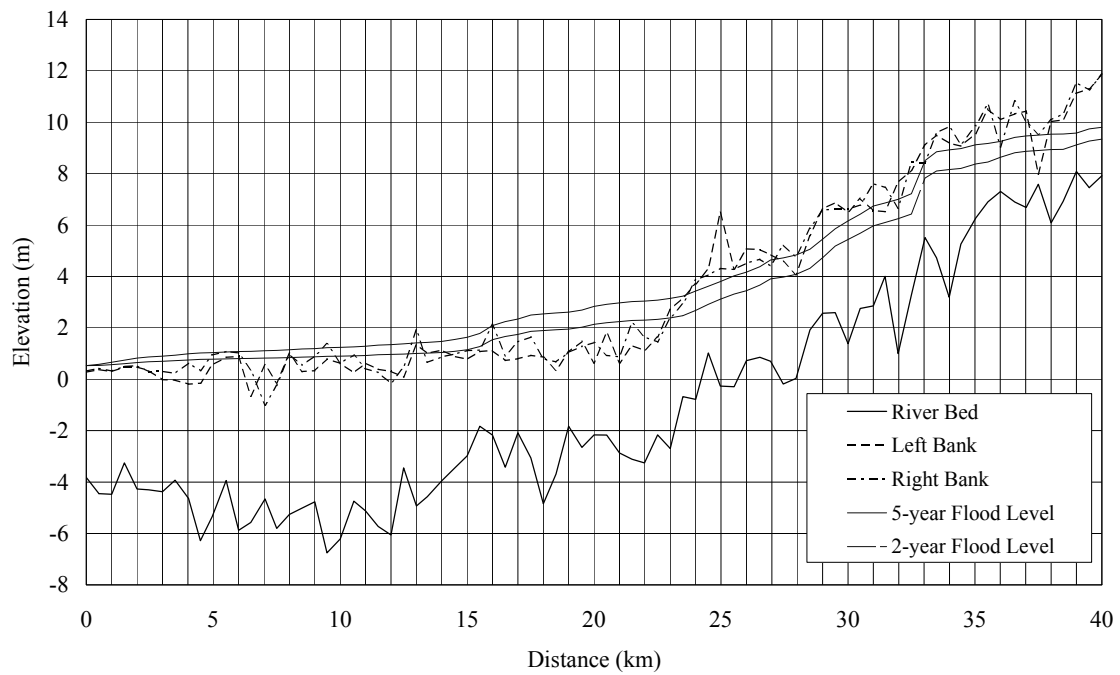

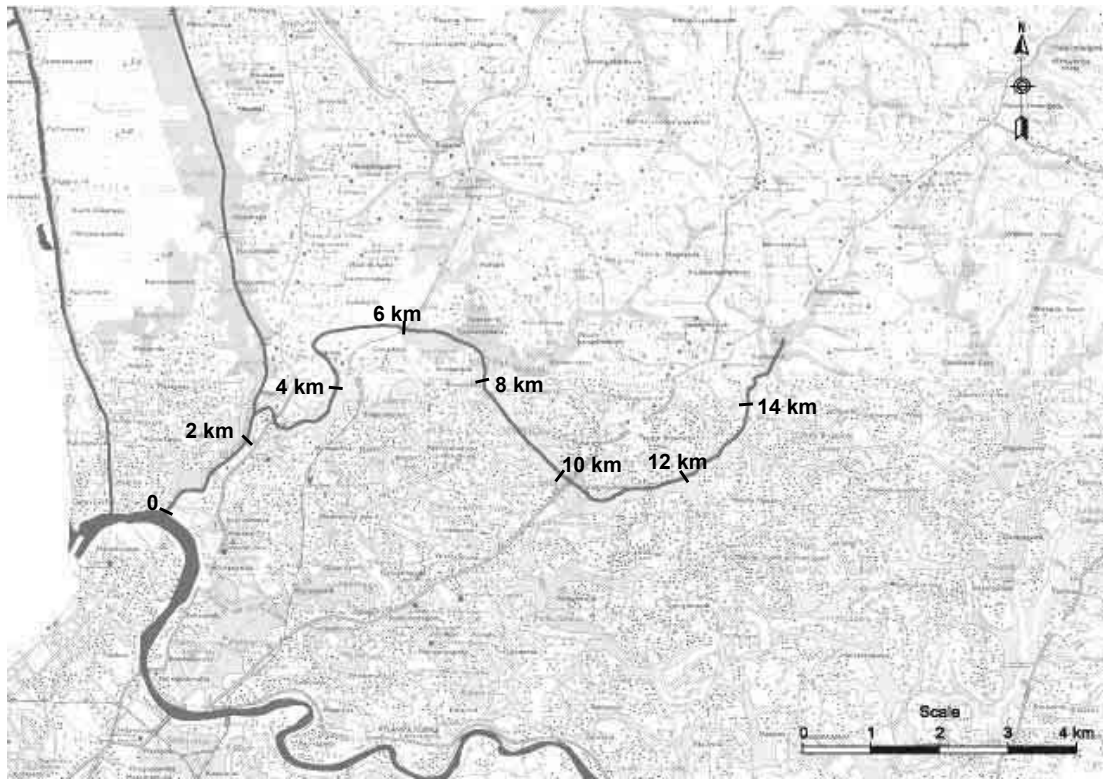

Kalu Oya

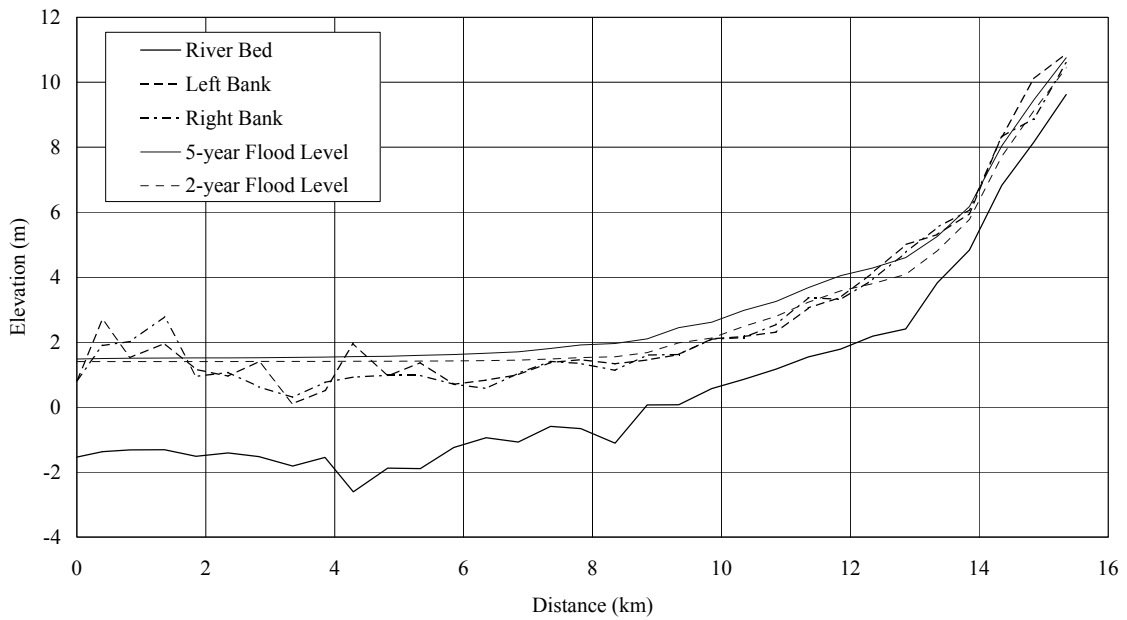

*The Study on Storm Water Drainage Plan
for the Colombo Metropolitan Region
in the Democratic Socialist Republic of Sri Lanka*
JAPAN INTERNATIONAL COOPERATION AGENCY

Figure 3.3.2
Longitudinal Profile of the Kalu Oya

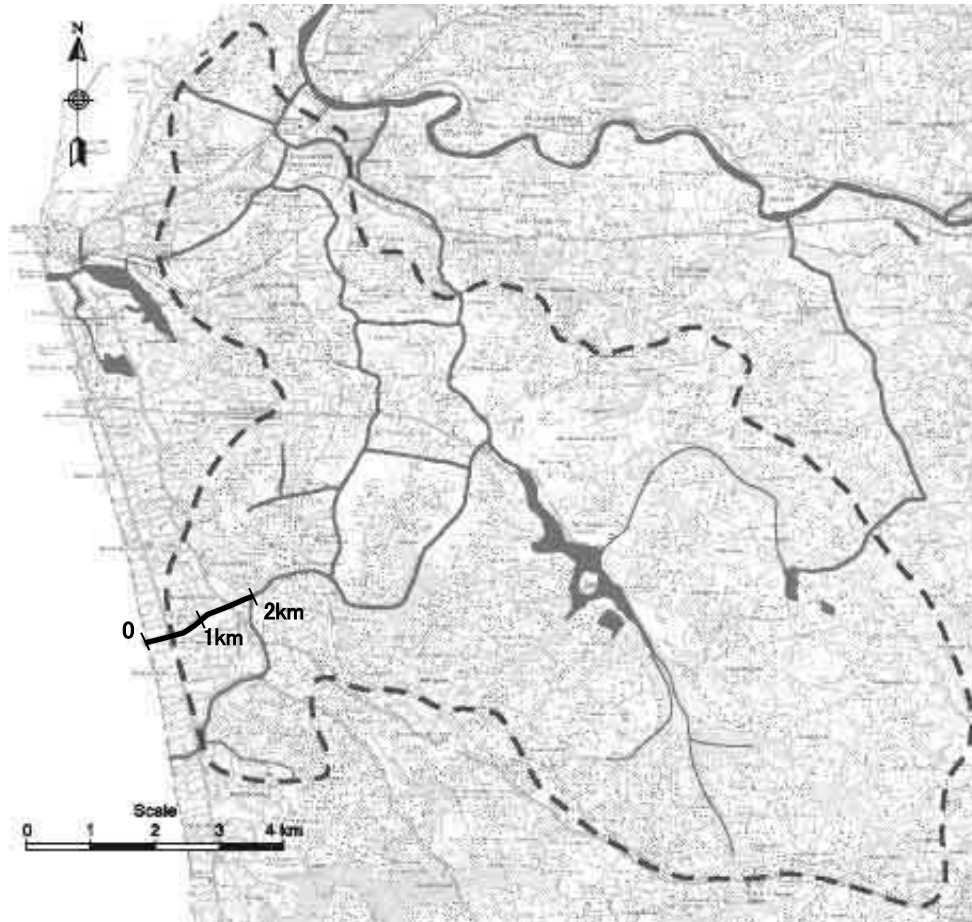

Wellawatta Canal

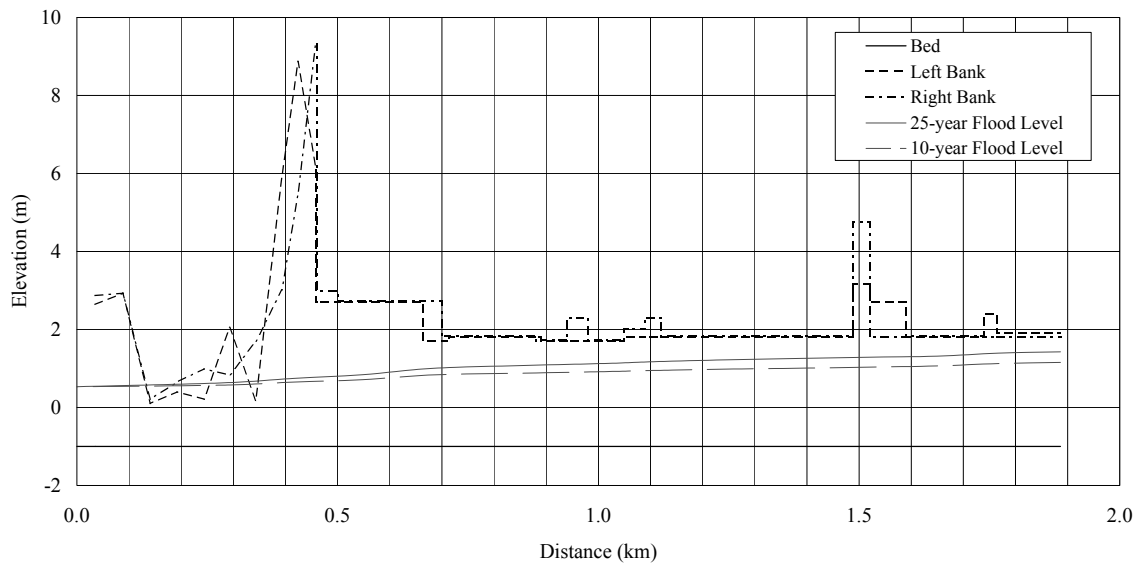

*The Study on Storm Water Drainage Plan
for the Colombo Metropolitan Region
in the Democratic Socialist Republic of Sri Lanka*
JAPAN INTERNATIONAL COOPERATION AGENCY

Figure 3.3.3
Longitudinal Profile of Main Canal in Greater Colombo
Basin (1/18)
(Wellawatta Canal)

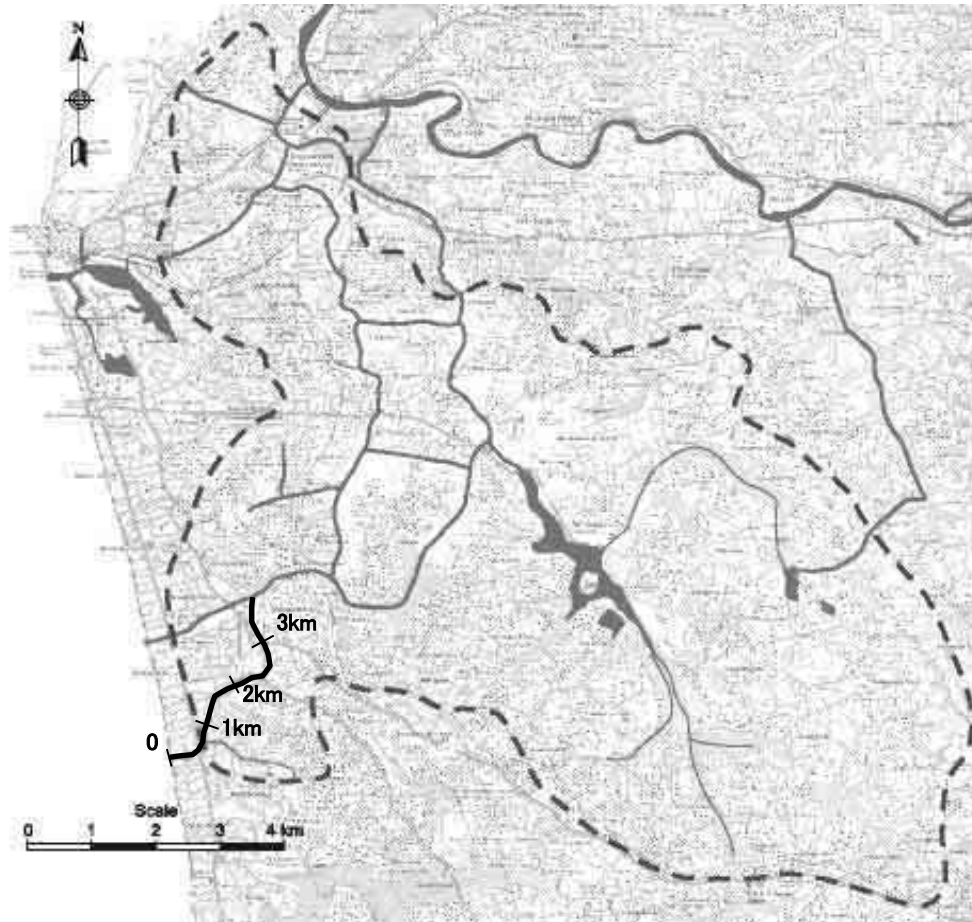

Dehiwala Canal

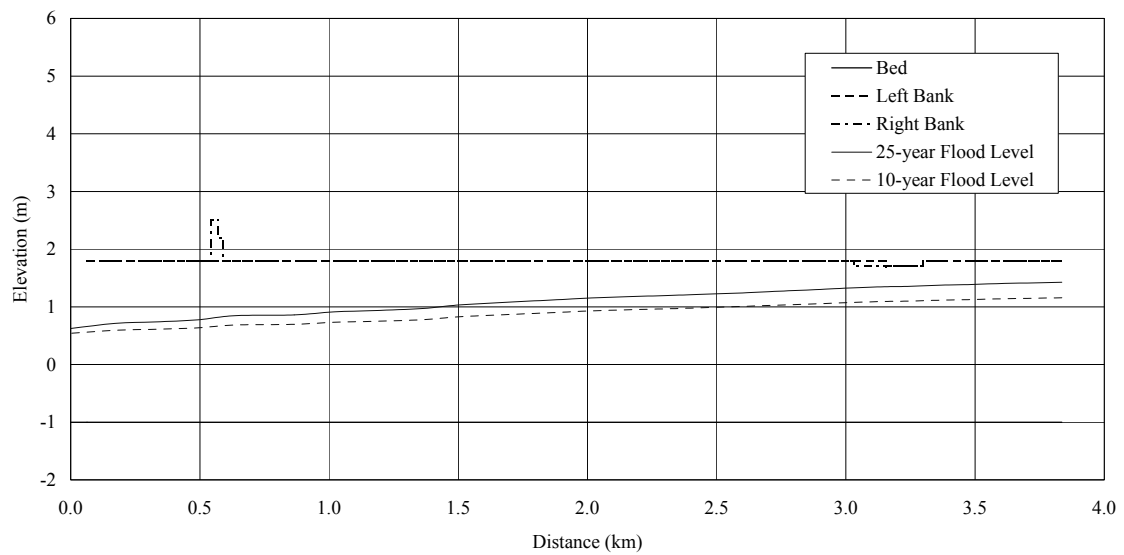

*The Study on Storm Water Drainage Plan
for the Colombo Metropolitan Region
in the Democratic Socialist Republic of Sri Lanka*
JAPAN INTERNATIONAL COOPERATION AGENCY

Figure 3.3.3
Longitudinal Profile of Main Canal in Greater Colombo
Basin (2/18)
(Dehiwala Canal)

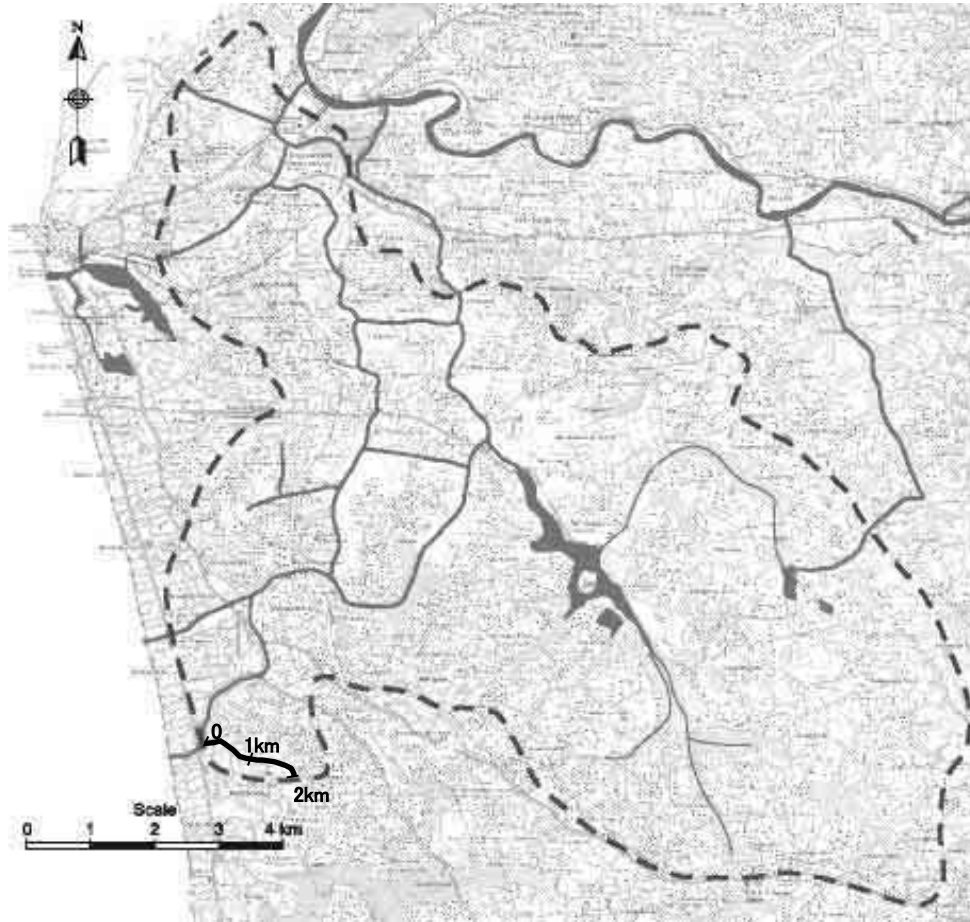

Bolgoda Canal

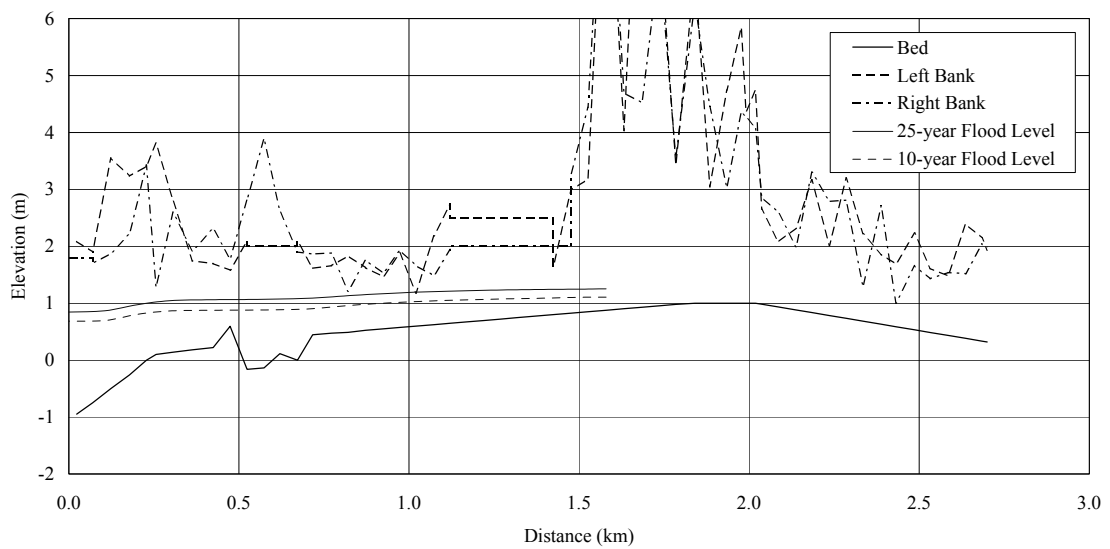

*The Study on Storm Water Drainage Plan
for the Colombo Metropolitan Region
in the Democratic Socialist Republic of Sri Lanka*

JAPAN INTERNATIONAL COOPERATION AGENCY

Figure 3.3.3
Longitudinal Profile of Main Canal in Greater
Colombo Basin (3/18)
(Bolgoda Canal)

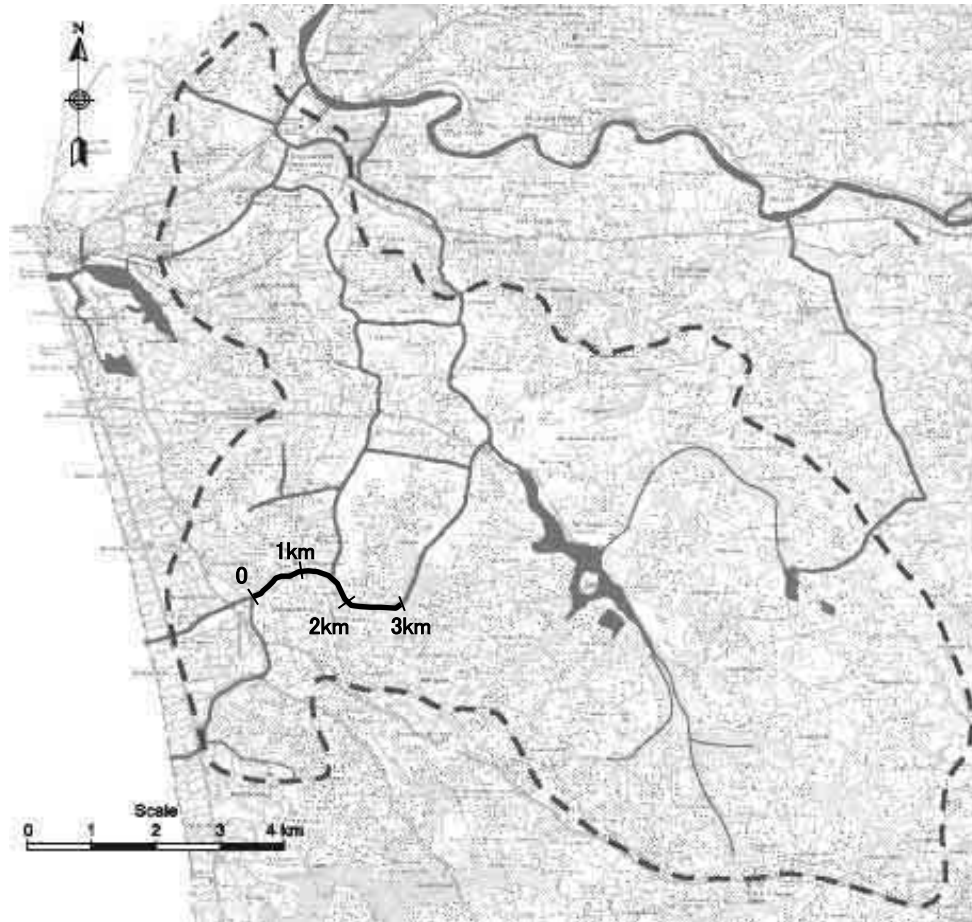

Kirillapone Canal

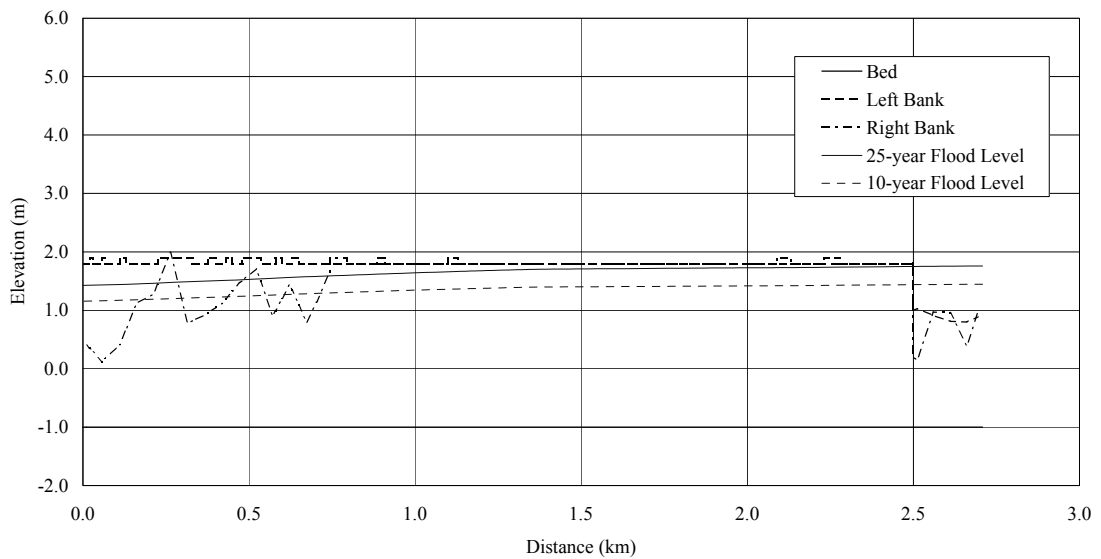

*The Study on Storm Water Drainage Plan
for the Colombo Metropolitan Region
in the Democratic Socialist Republic of Sri Lanka*

JAPAN INTERNATIONAL COOPERATION AGENCY

Figure 3.3.3
Longitudinal Profile of Main Canal in Greater
Colombo Basin (4/18)
(Kirillapone Canal)

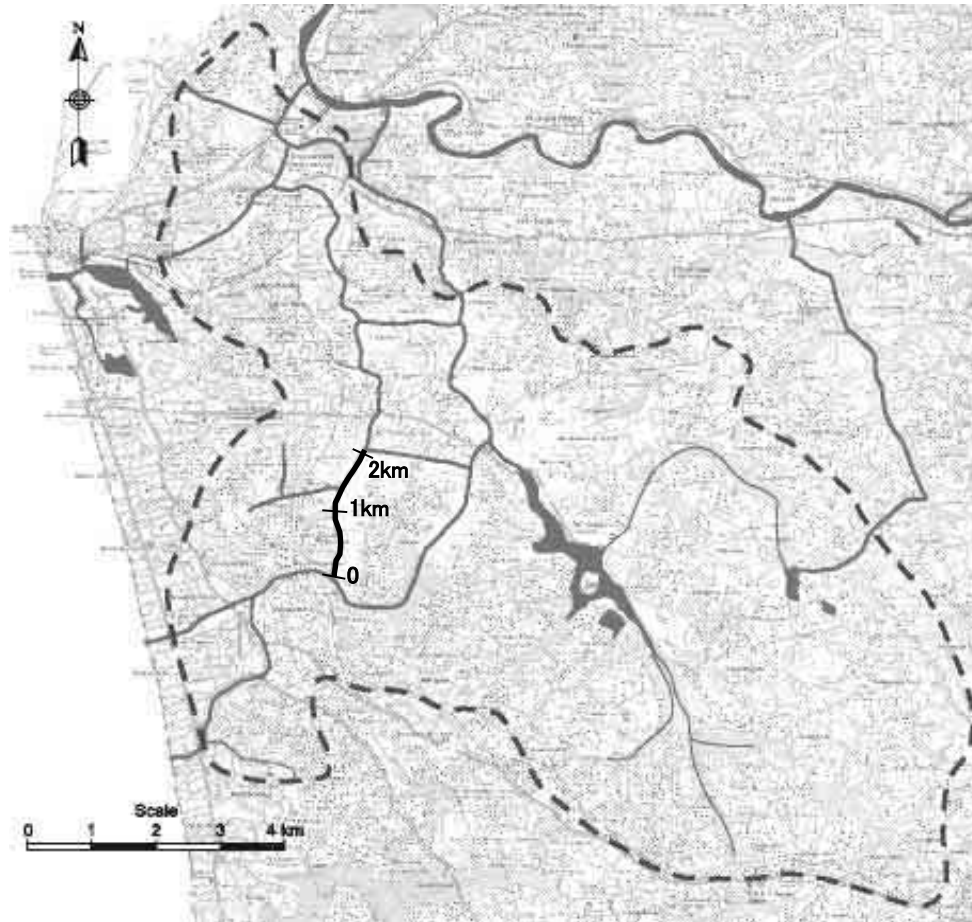

Heen Ela

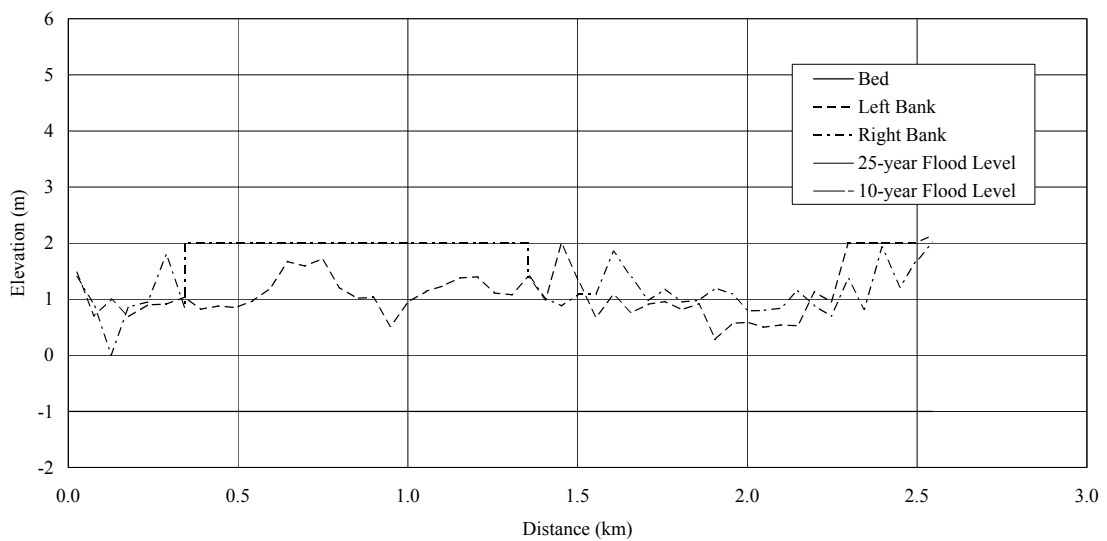

*The Study on Storm Water Drainage Plan
for the Colombo Metropolitan Region
in the Democratic Socialist Republic of Sri Lanka*

JAPAN INTERNATIONAL COOPERATION AGENCY

Figure 3.3.3
Longitudinal Profile of Main Canal in Greater
Colombo Basin (5/18)
(Heen Ela)

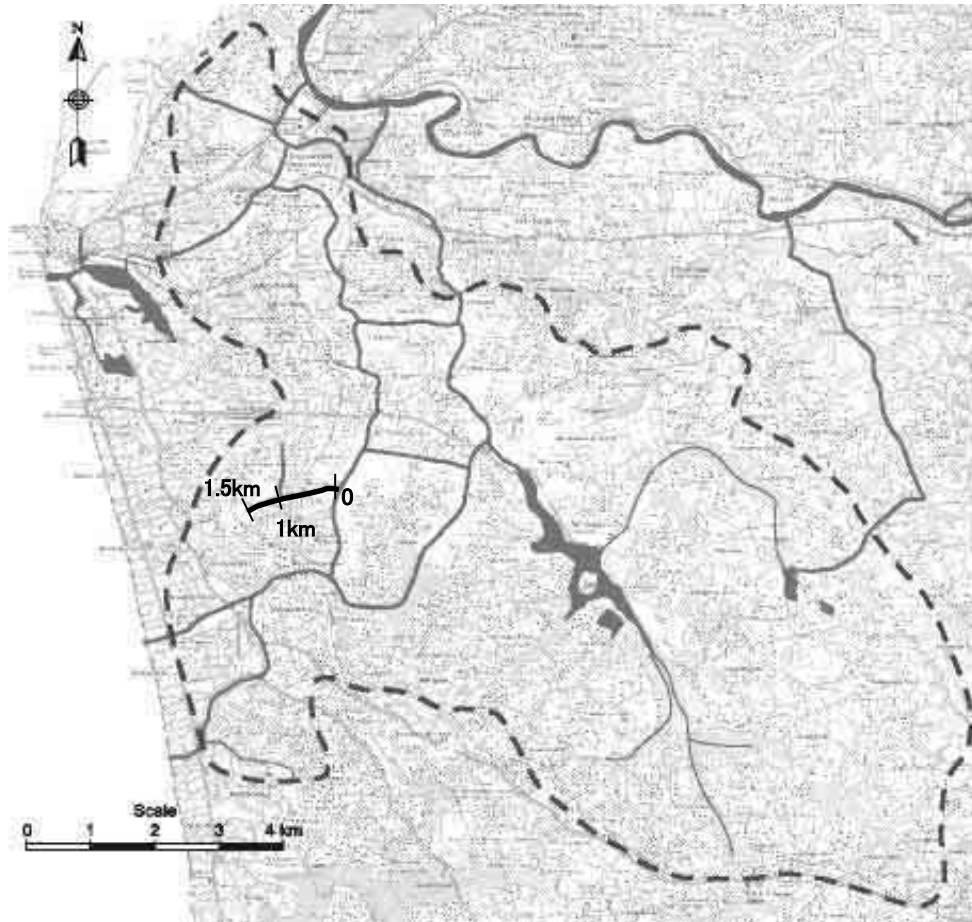

Torrington South Canal

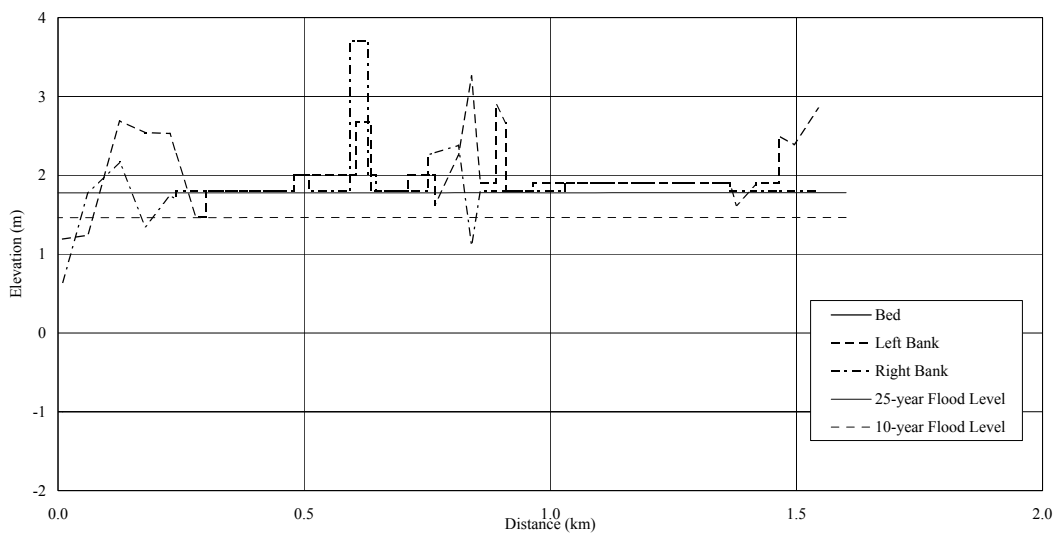

*The Study on Storm Water Drainage Plan
for the Colombo Metropolitan Region
in the Democratic Socialist Republic of Sri Lanka*
JAPAN INTERNATIONAL COOPERATION AGENCY

Figure 3.3.3
Longitudinal Profile of Main Canal in Greater
Colombo Basin (6/18)
(Torrington South Canal)

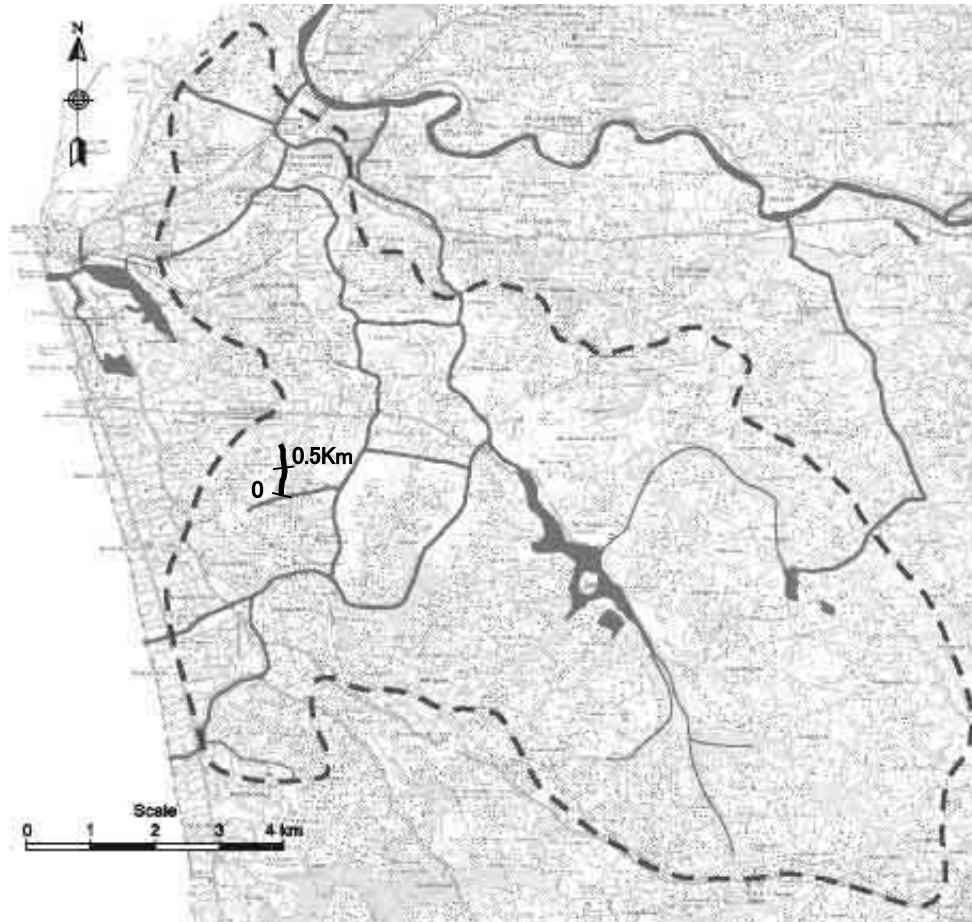

Torrington North Canal

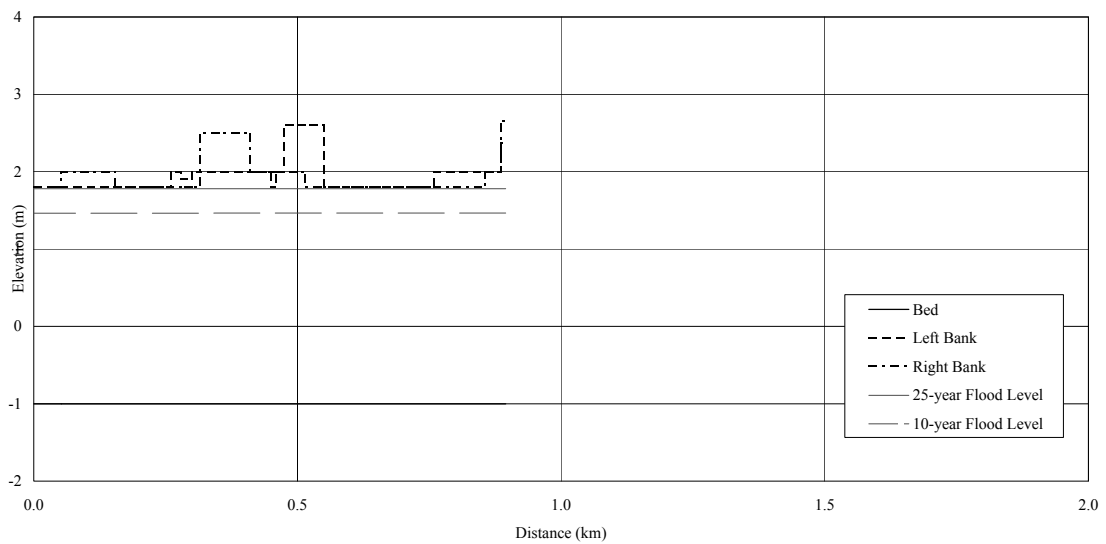

*The Study on Storm Water Drainage Plan
for the Colombo Metropolitan Region
in the Democratic Socialist Republic of Sri Lanka*
JAPAN INTERNATIONAL COOPERATION AGENCY

Figure 3.3.3
Longitudinal Profile of Main Canal in Greater
Colombo Basin (7/18)
(Torrington North Canal)

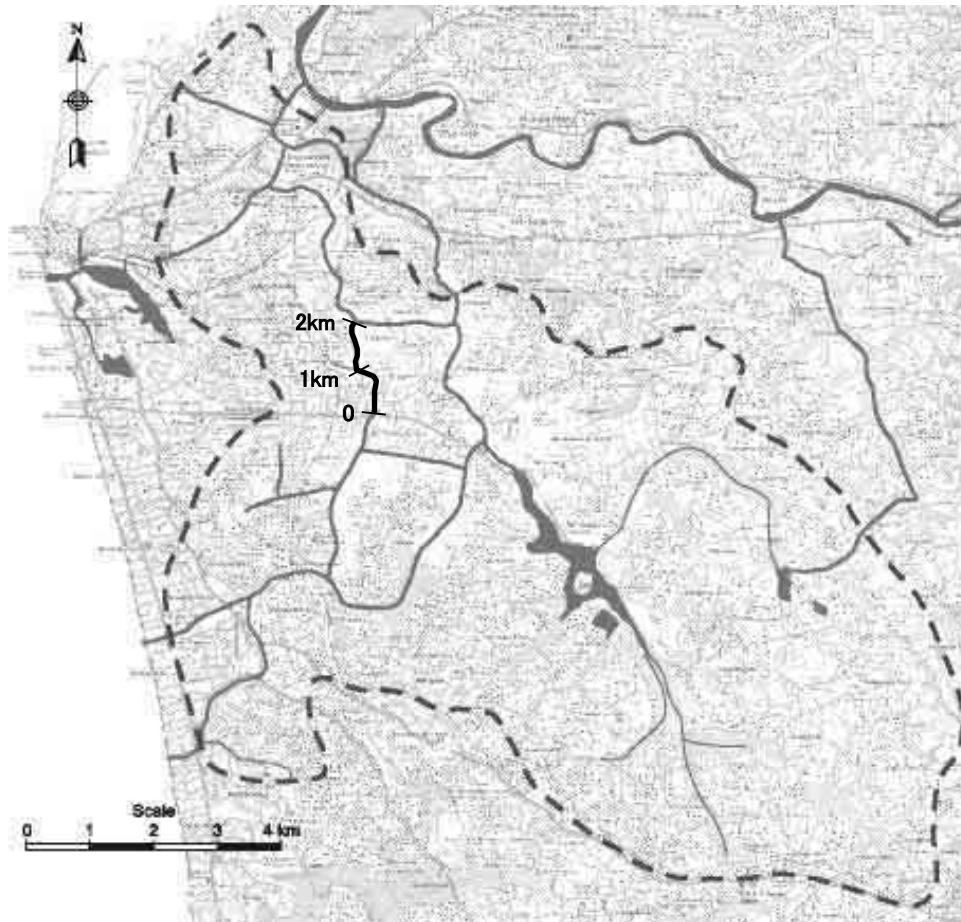

Mahawatta Ela - Connection Canal to Heen Ela

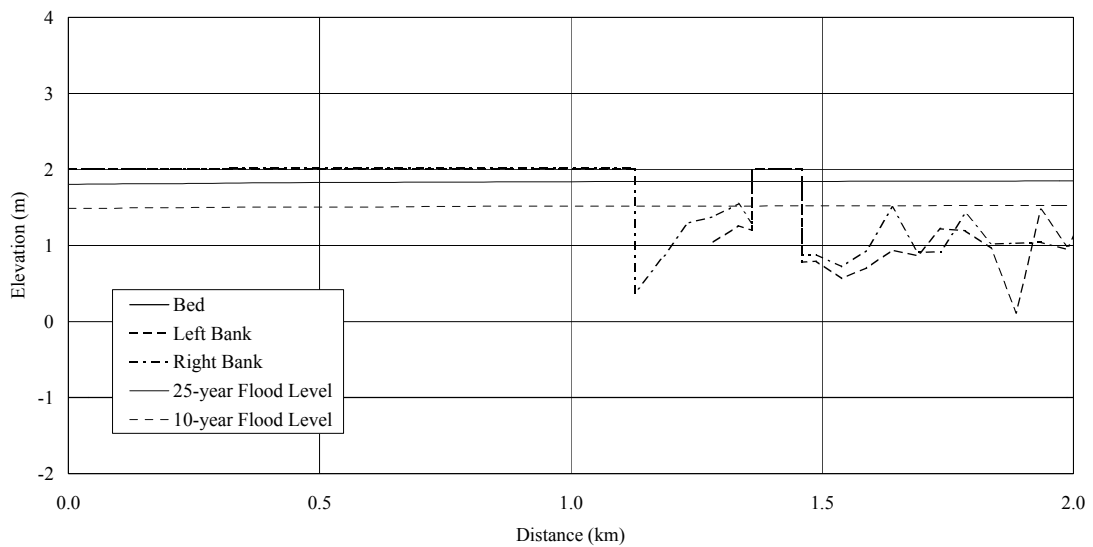

<p><i>The Study on Storm Water Drainage Plan for the Colombo Metropolitan Region in the Democratic Socialist Republic of Sri Lanka</i></p>	<p>Figure 3.3.3 Longitudinal Profile of Main Canal in Greater Colombo Basin (8/18)</p>
<p>JAPAN INTERNATIONAL COOPERATION AGENCY</p>	<p>(Mahawatta Ela and Connection Canal to Heen Ela)</p>

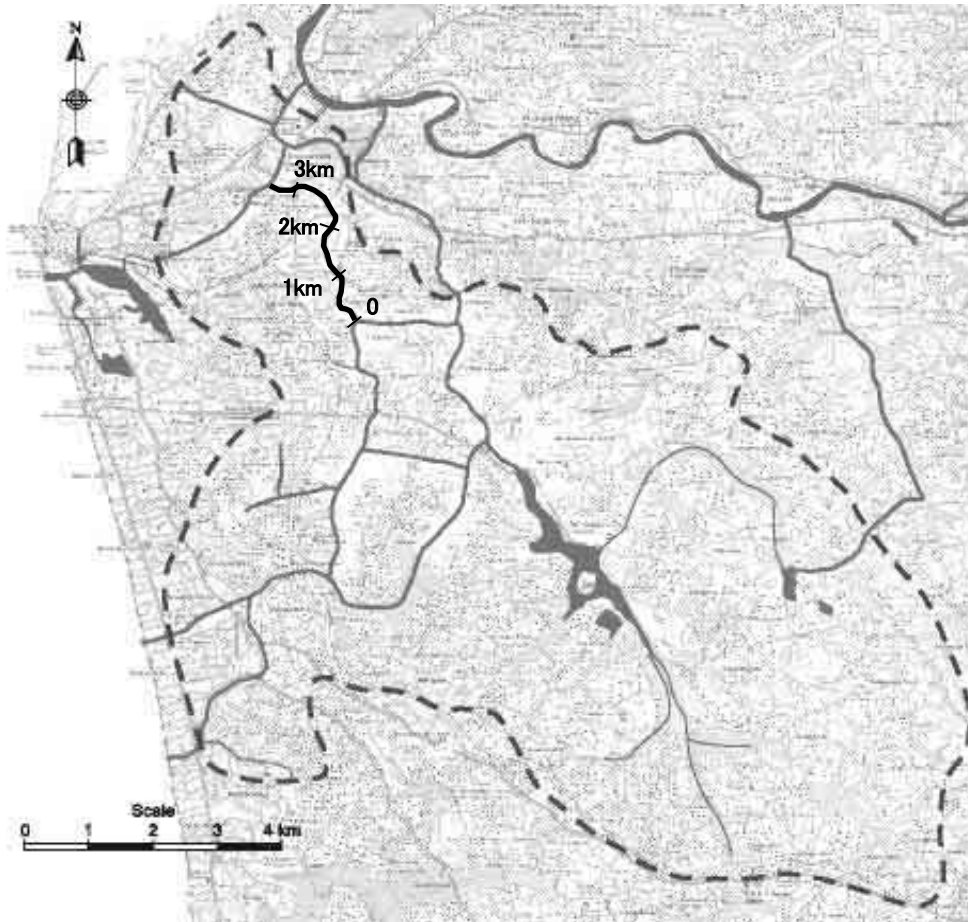

Dematagoda Ela

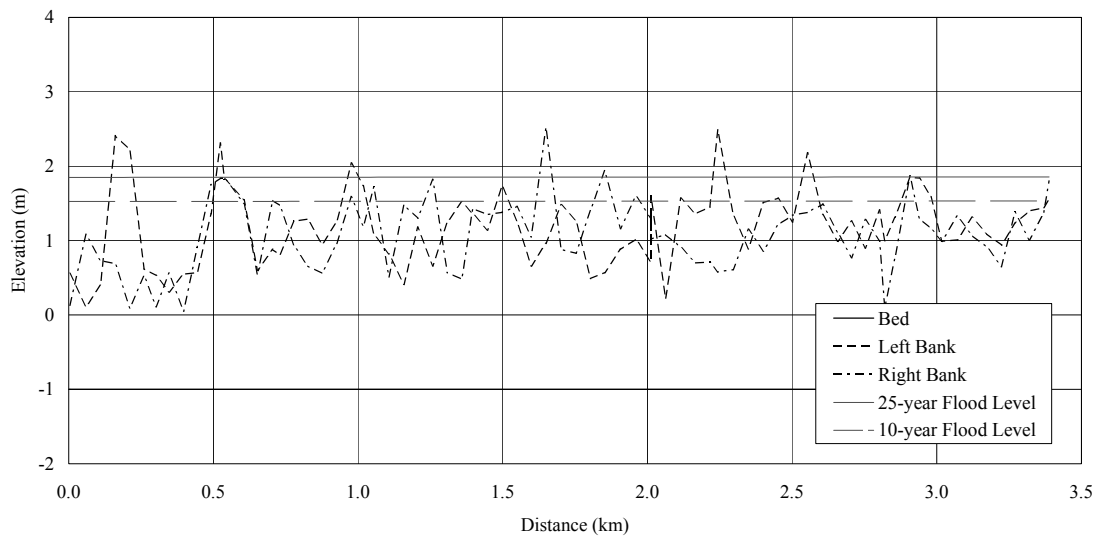

*The Study on Storm Water Drainage Plan
for the Colombo Metropolitan Region
in the Democratic Socialist Republic of Sri Lanka*

JAPAN INTERNATIONAL COOPERATION AGENCY

Figure 3.3.3
Longitudinal Profile of Main Canal in Greater
Colombo Basin (9/18)
(Dematagoda Ela)

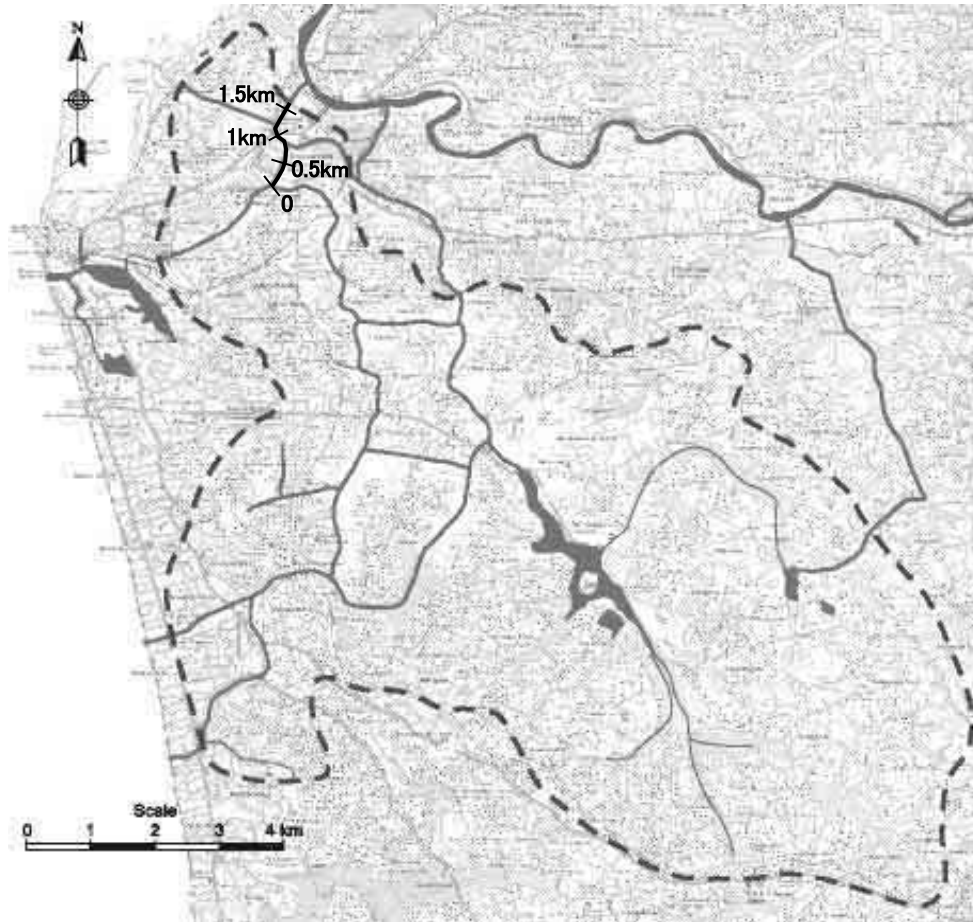

St. Sebastian North Canal

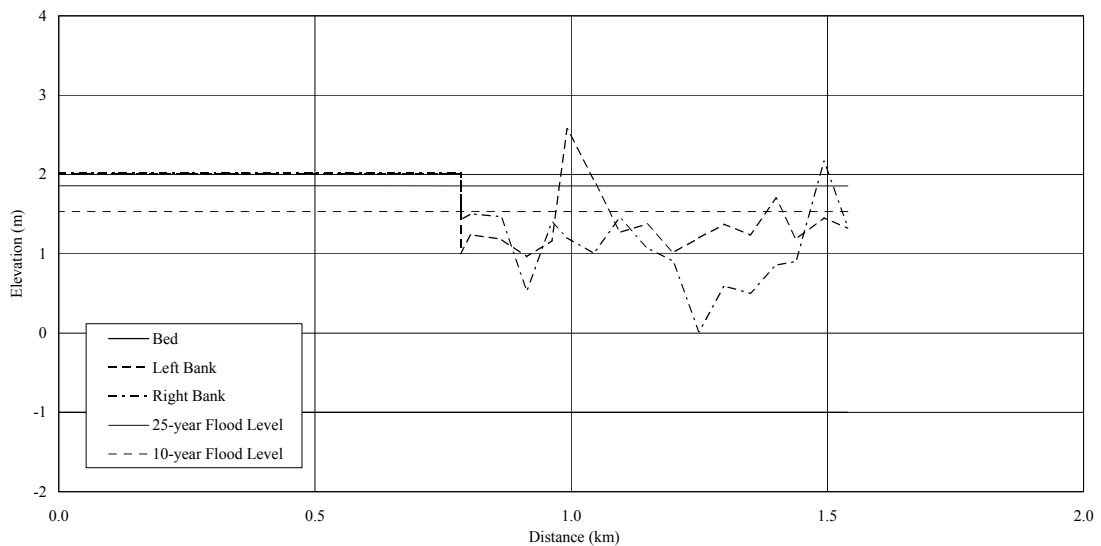

*The Study on Storm Water Drainage Plan
for the Colombo Metropolitan Region
in the Democratic Socialist Republic of Sri Lanka*

JAPAN INTERNATIONAL COOPERATION AGENCY

Figure 3.3.3
Longitudinal Profile of Main Canal in Greater
Colombo Basin (10/18)
(St. Sebastian North Canal)

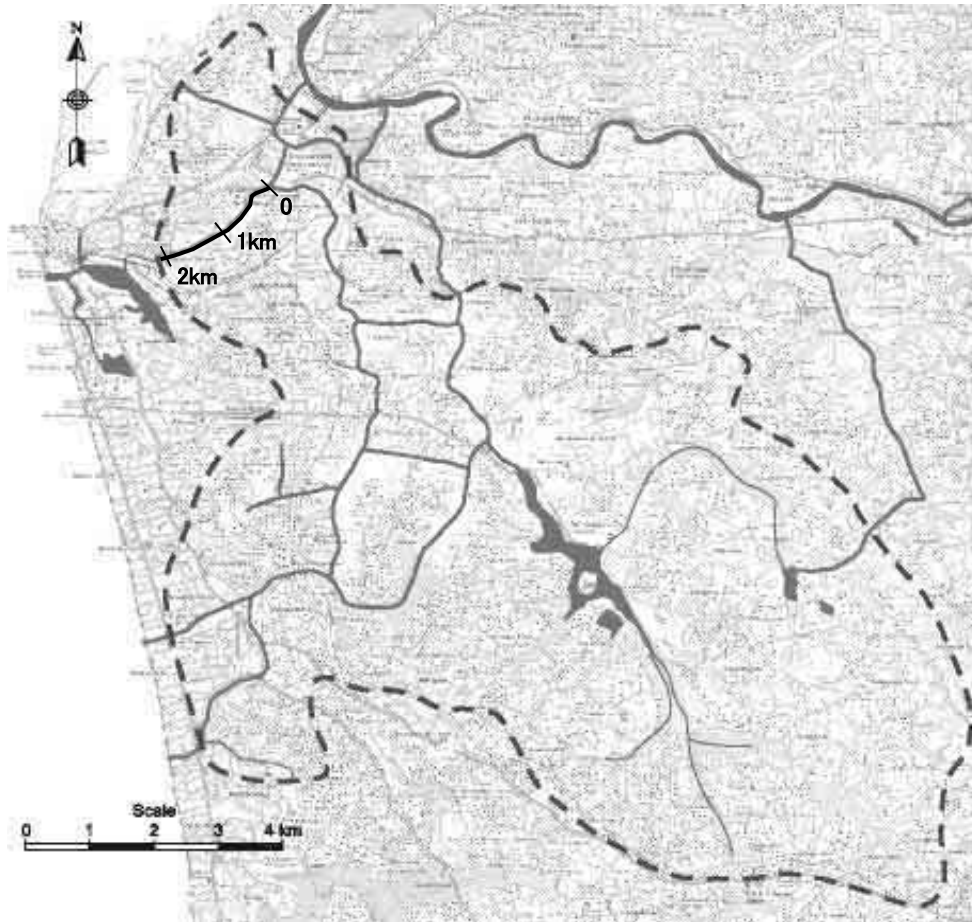

St. Sebastian South Canal

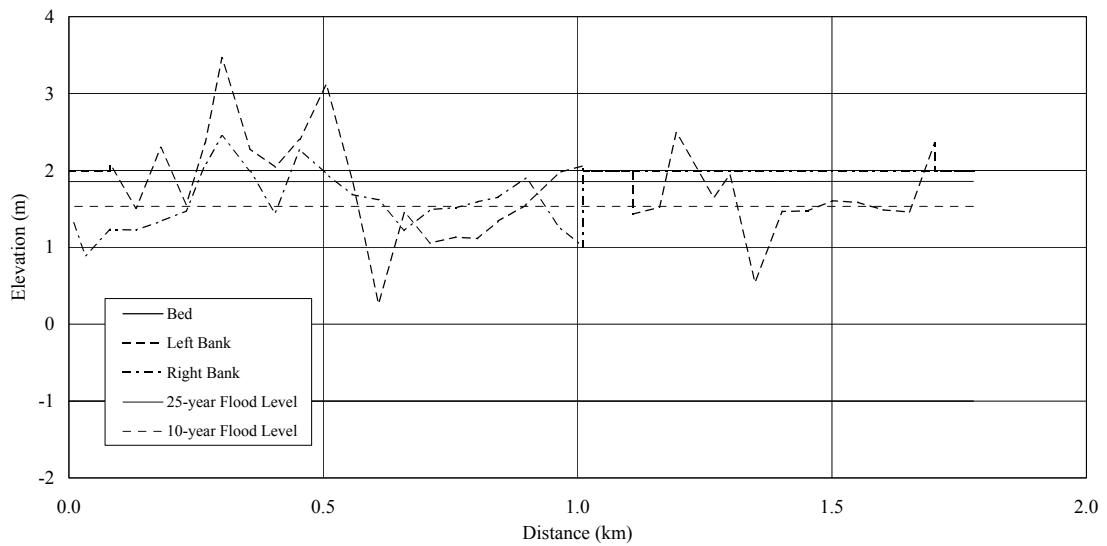

*The Study on Storm Water Drainage Plan
for the Colombo Metropolitan Region
in the Democratic Socialist Republic of Sri Lanka*

JAPAN INTERNATIONAL COOPERATION AGENCY

Figure 3.3.3
Longitudinal Profile of Main Canal in Greater
Colombo Basin (11/18)
(St. Sebastian South Canal)

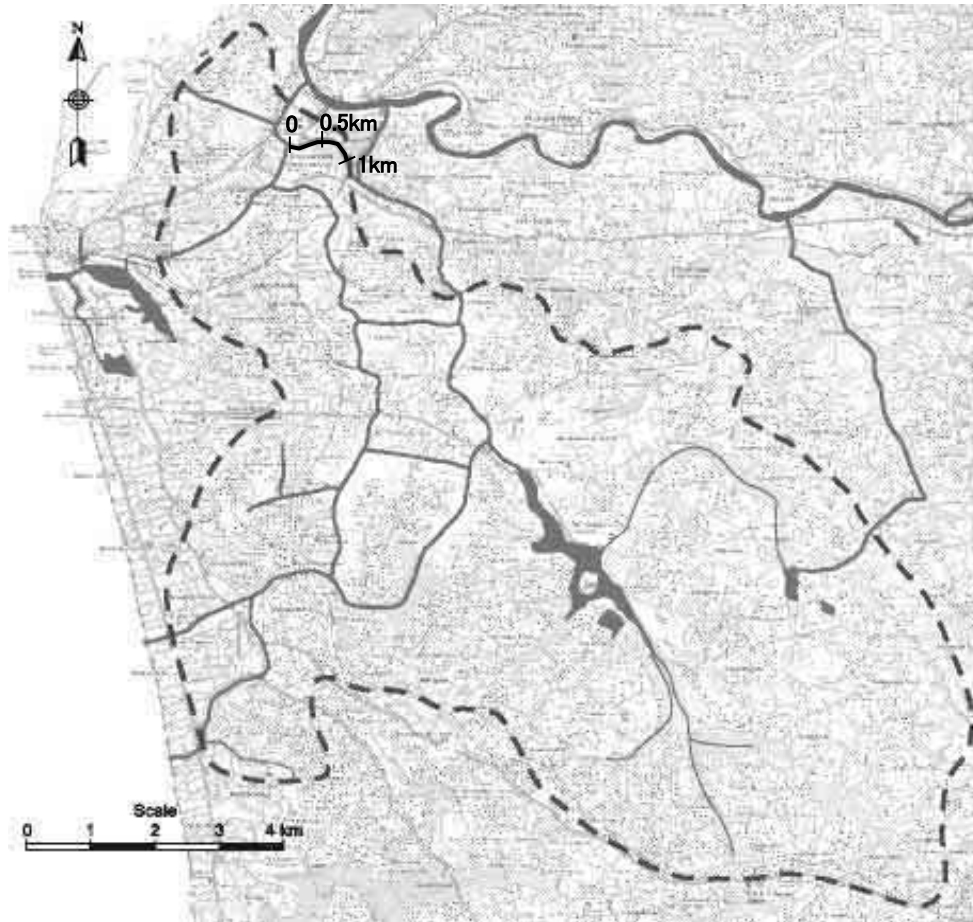

St. Sebastian East Canal

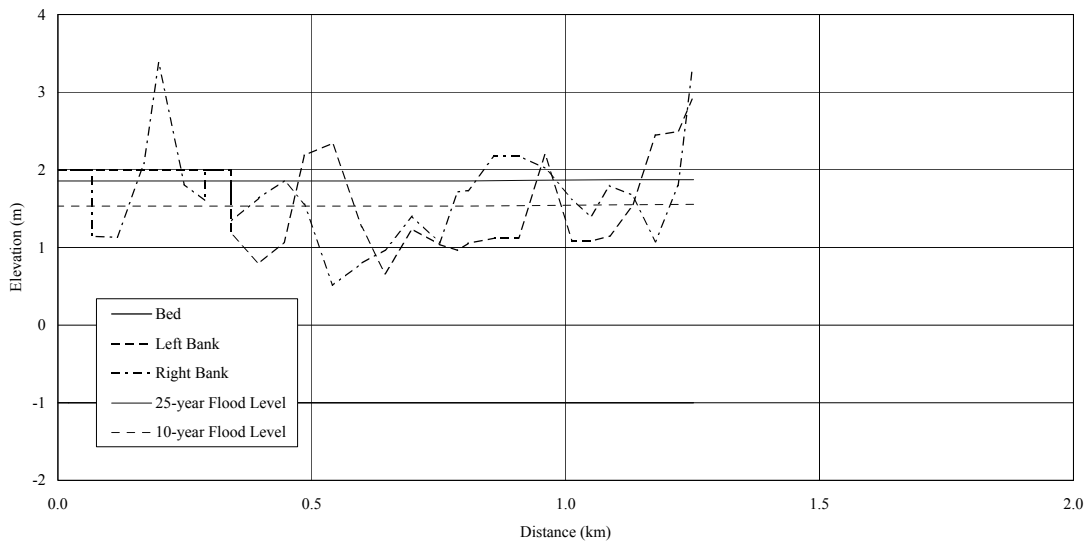

*The Study on Storm Water Drainage Plan
for the Colombo Metropolitan Region
in the Democratic Socialist Republic of Sri Lanka*

JAPAN INTERNATIONAL COOPERATION AGENCY

Figure 3.3.3
Longitudinal Profile of Main Canal in Greater
Colombo Basin (12/18)
(St. Sebastian East Canal)

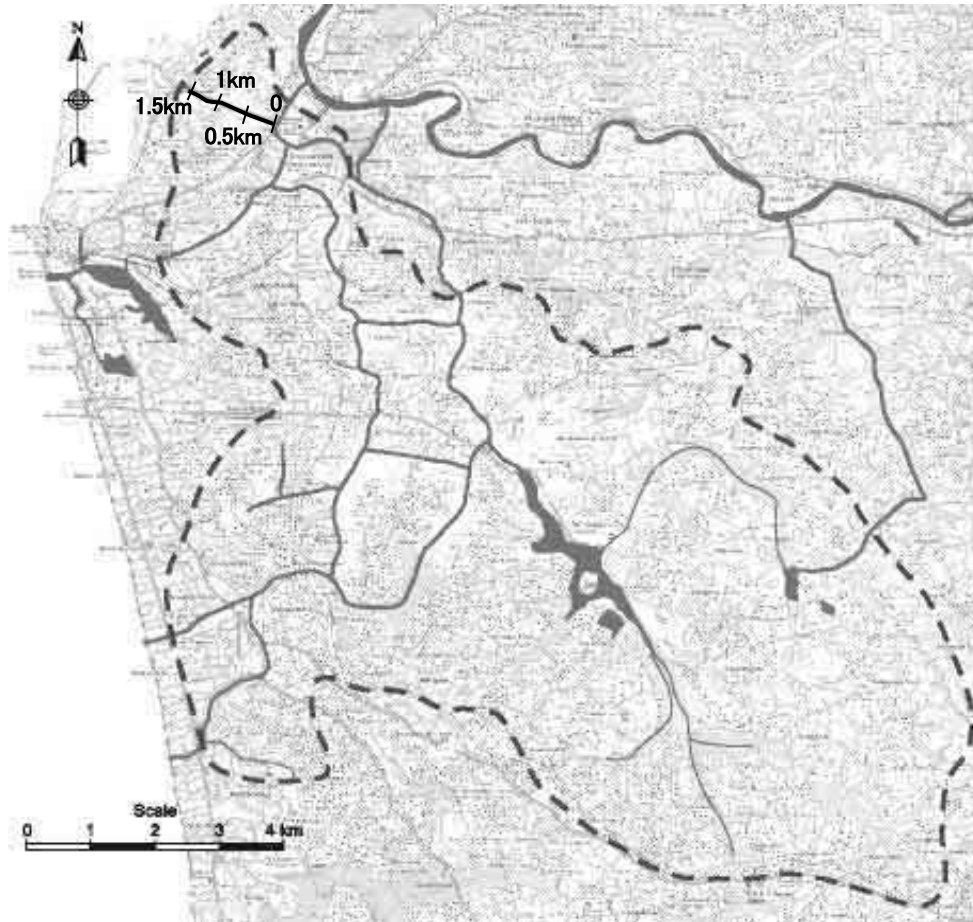

Main Drain

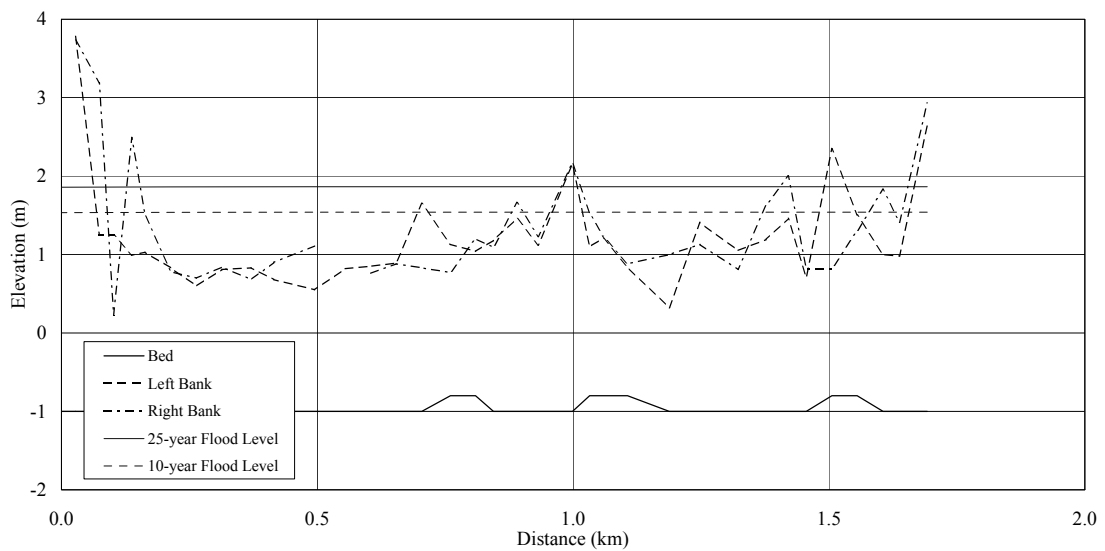

*The Study on Storm Water Drainage Plan
for the Colombo Metropolitan Region
in the Democratic Socialist Republic of Sri Lanka*

JAPAN INTERNATIONAL COOPERATION AGENCY

Figure 3.3.3
Longitudinal Profile of Main Canal in Greater
Colombo Basin (13/18)
(Main Drain)

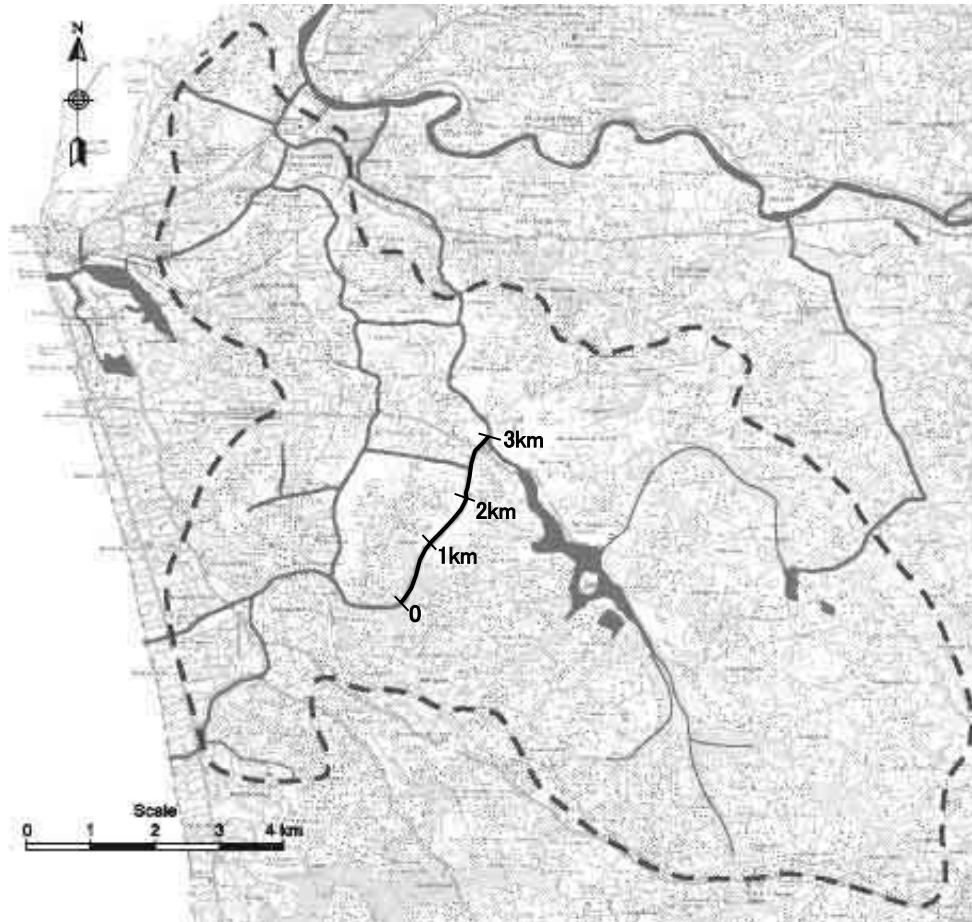

Kotte Ela

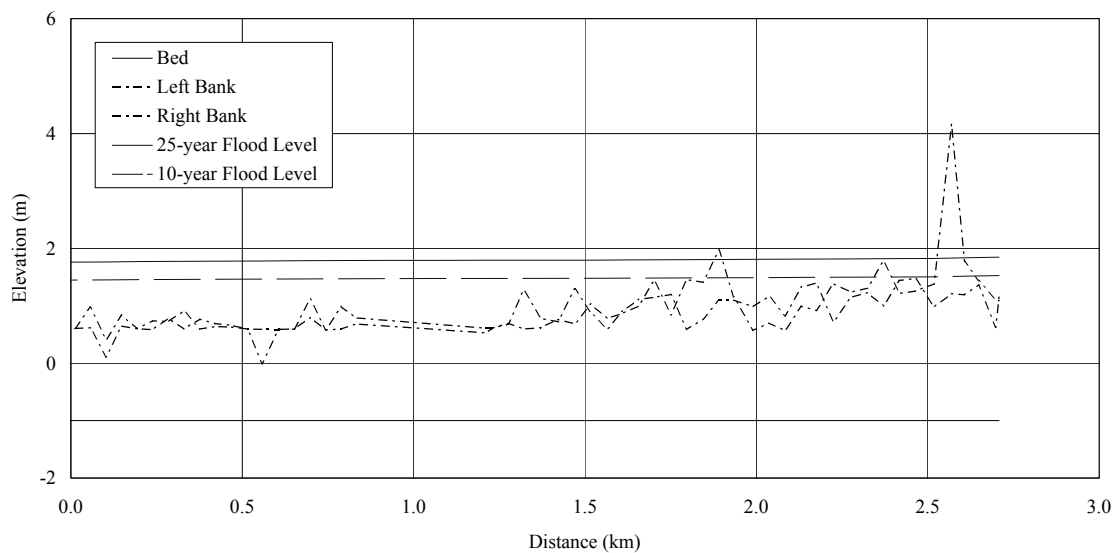

*The Study on Storm Water Drainage Plan
for the Colombo Metropolitan Region
in the Democratic Socialist Republic of Sri Lanka*
JAPAN INTERNATIONAL COOPERATION AGENCY

Figure 3.3.3
Longitudinal Profile of Main Canal in Greater
Colombo Basin (14/18)
(Kotte Ela)

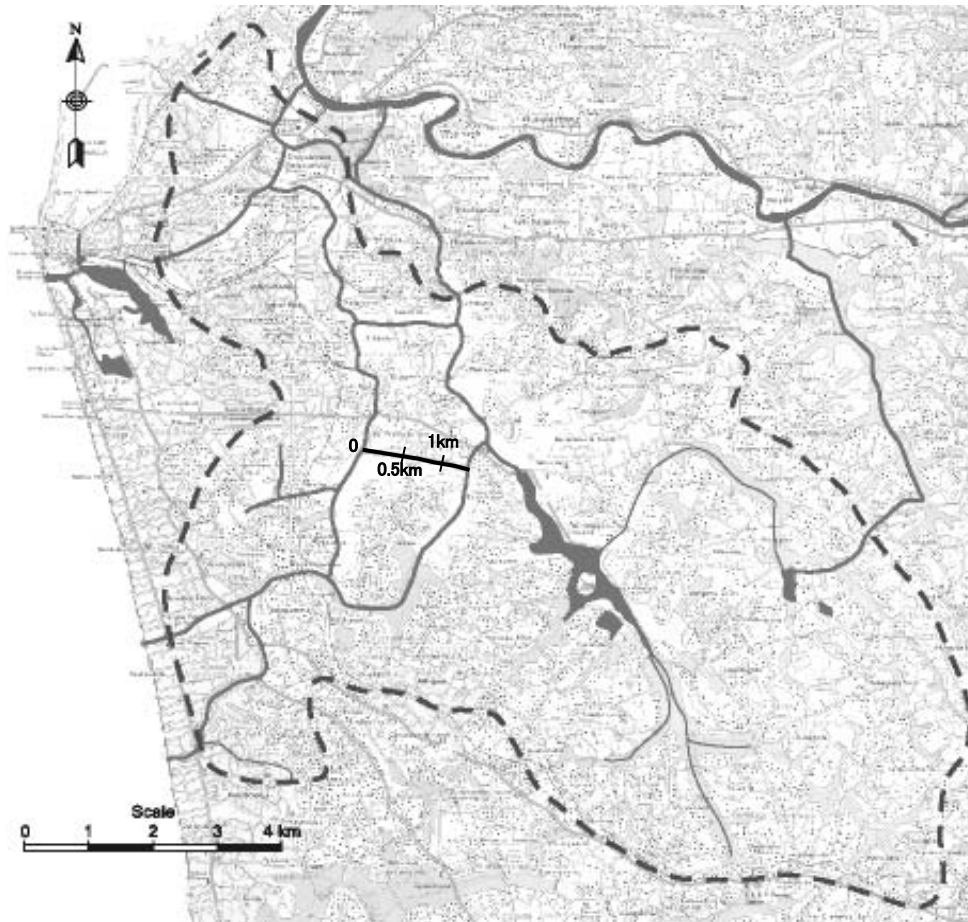

Connection Kotte Ela North - Heen Ela

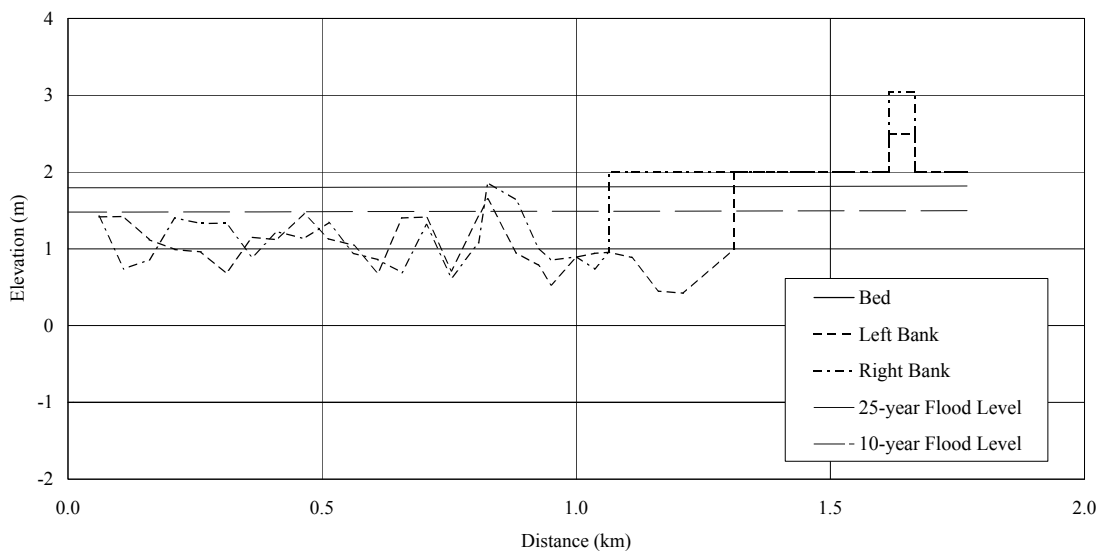

*The Study on Storm Water Drainage Plan
for the Colombo Metropolitan Region
in the Democratic Socialist Republic of Sri Lanka*
JAPAN INTERNATIONAL COOPERATION AGENCY

Figure 3.3.3
Longitudinal Profile of Main Canal in Greater
Colombo Basin (15/18)
(Connection Kotte Ela North - Heen Ela)

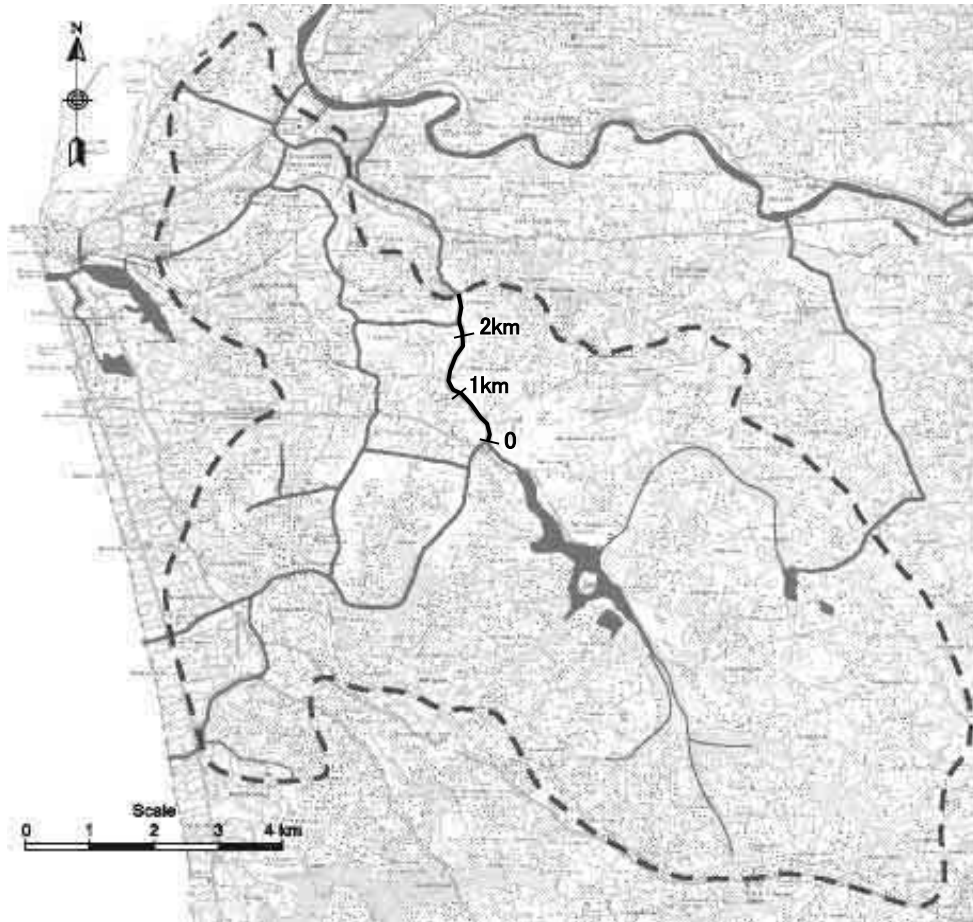

Kolonnawa Ela

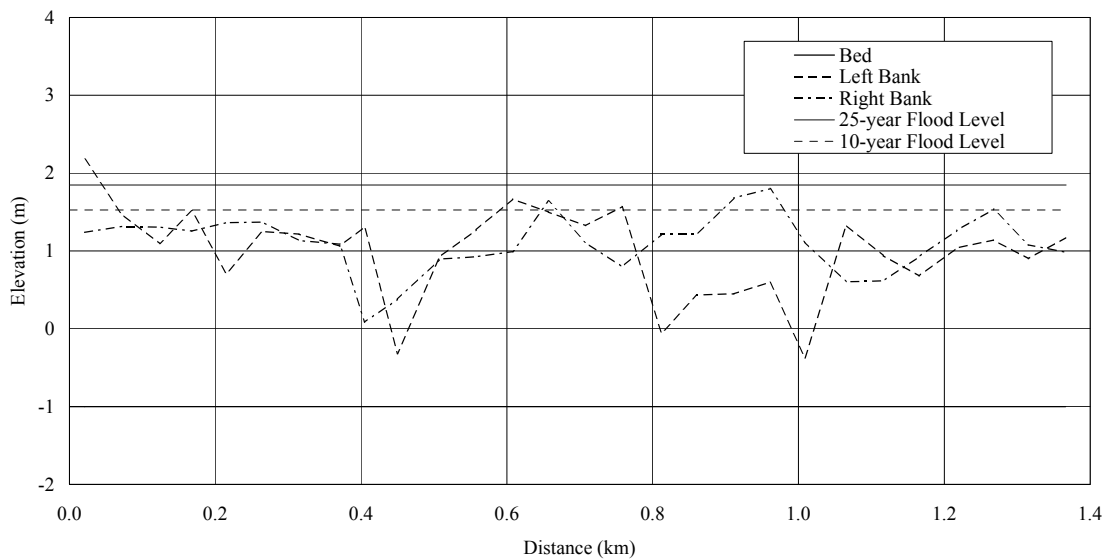

*The Study on Storm Water Drainage Plan
for the Colombo Metropolitan Region
in the Democratic Socialist Republic of Sri Lanka*

JAPAN INTERNATIONAL COOPERATION AGENCY

Figure 3.3.3
Longitudinal Profile of Main Canal in Greater
Colombo Basin (16/18)
(Kolonnawa Ela)

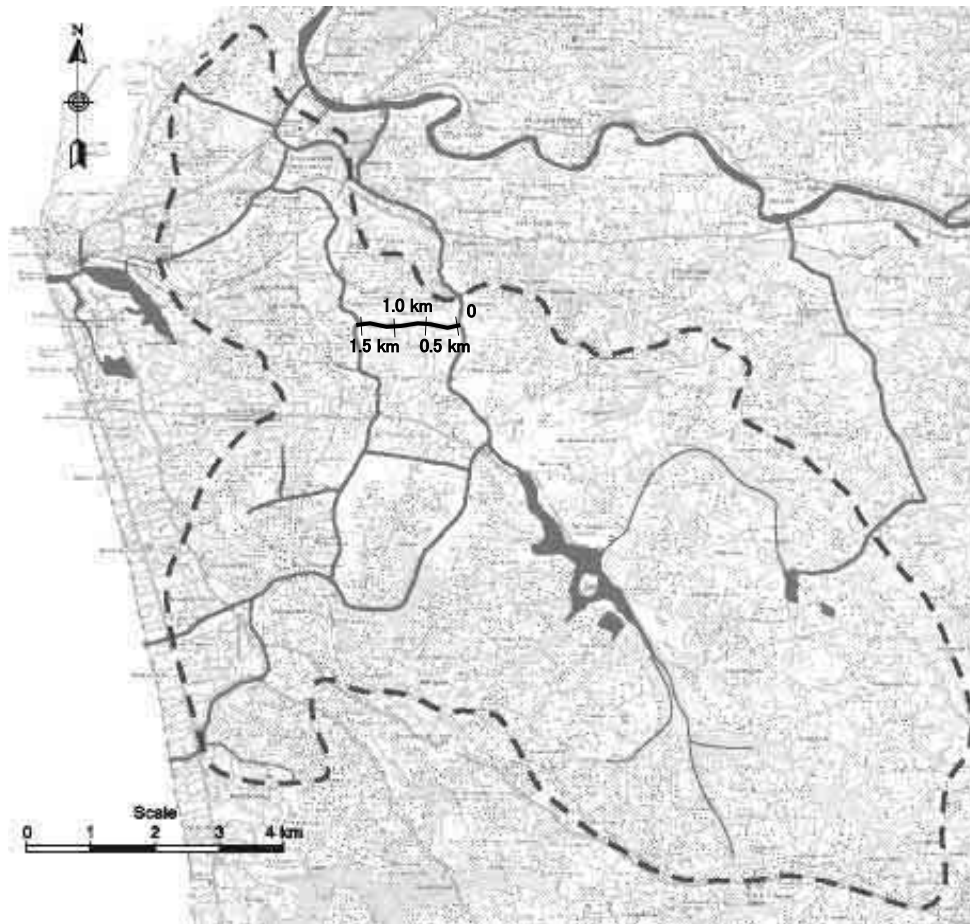

Kolonnawa Ela North

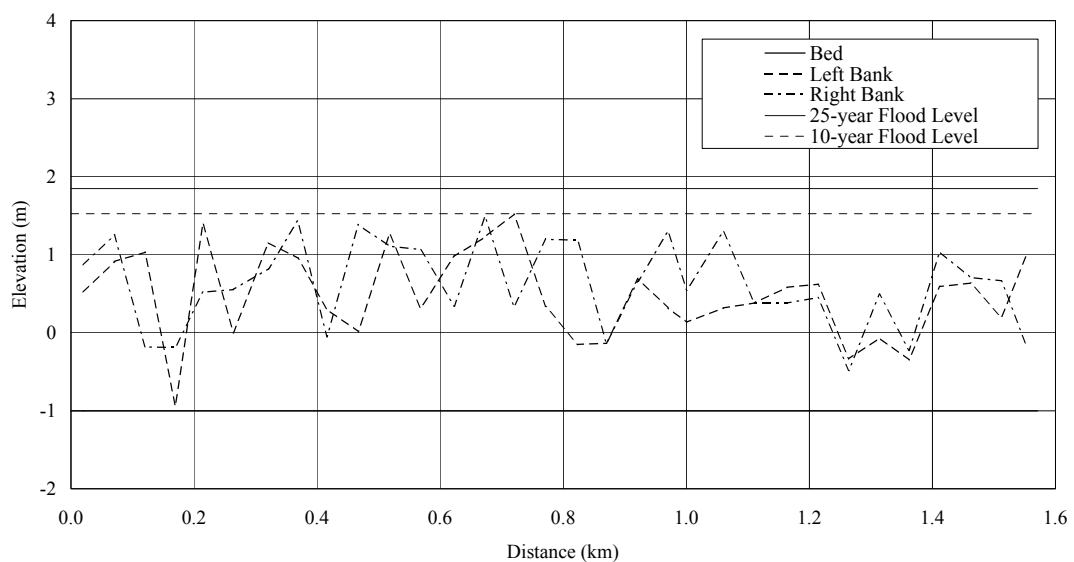

*The Study on Storm Water Drainage Plan
for the Colombo Metropolitan Region
in the Democratic Socialist Republic of Sri Lanka*
JAPAN INTERNATIONAL COOPERATION AGENCY

Figure 3.3.3
Longitudinal Profile of Main Canal in Greater
Colombo Basin (17/18)
(Kolonnawa Ela North)

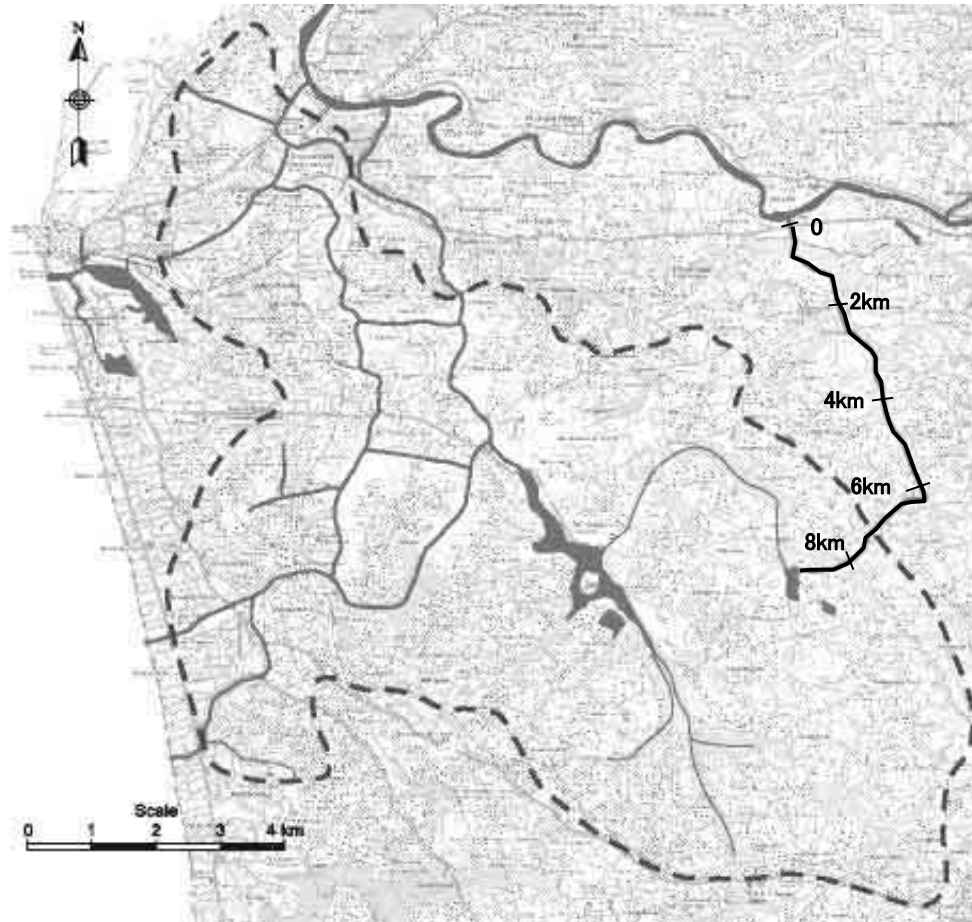

Madiwela East Diversion Canal

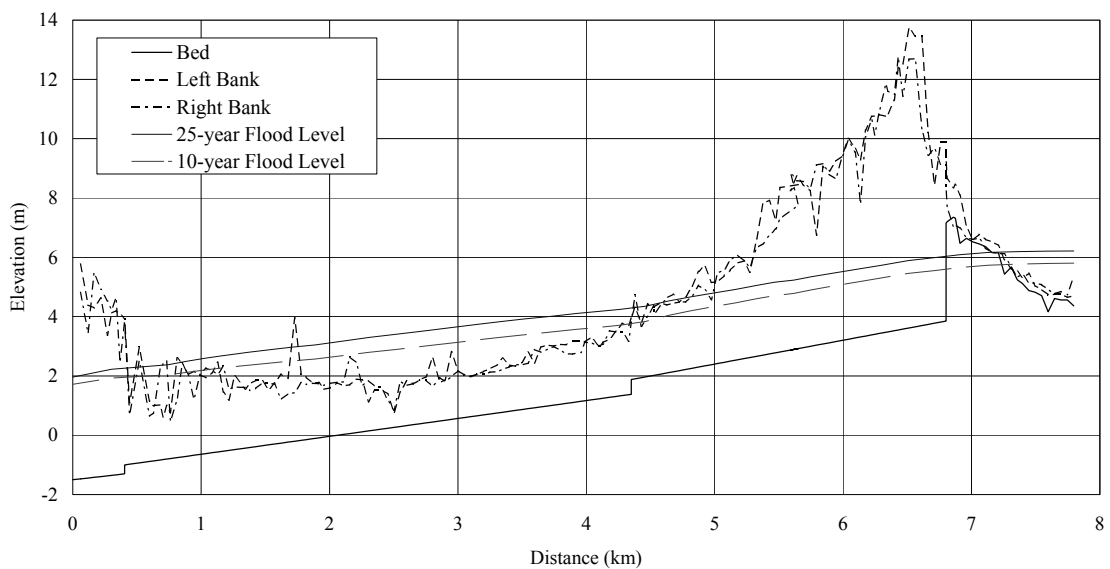

*The Study on Storm Water Drainage Plan
for the Colombo Metropolitan Region
in the Democratic Socialist Republic of Sri Lanka*
JAPAN INTERNATIONAL COOPERATION AGENCY

Figure 3.3.3
Longitudinal Profile of Main Canal in Greater
Colombo Basin (18/18)
(Madiwela East Diversion Canal)

Figure 3.3.4
Longitudinal Profile of Major Stream in
Bolgoda Basin (Weras Ganga) (1/7)

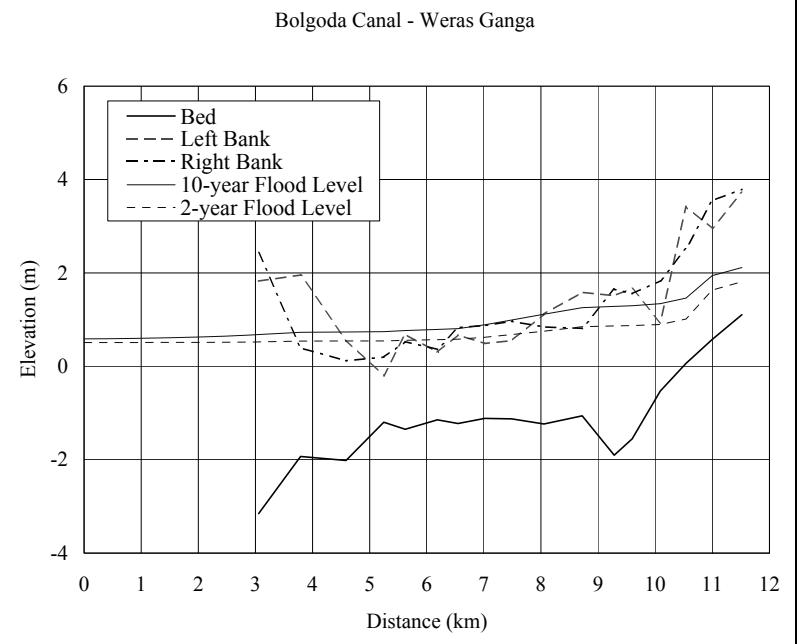
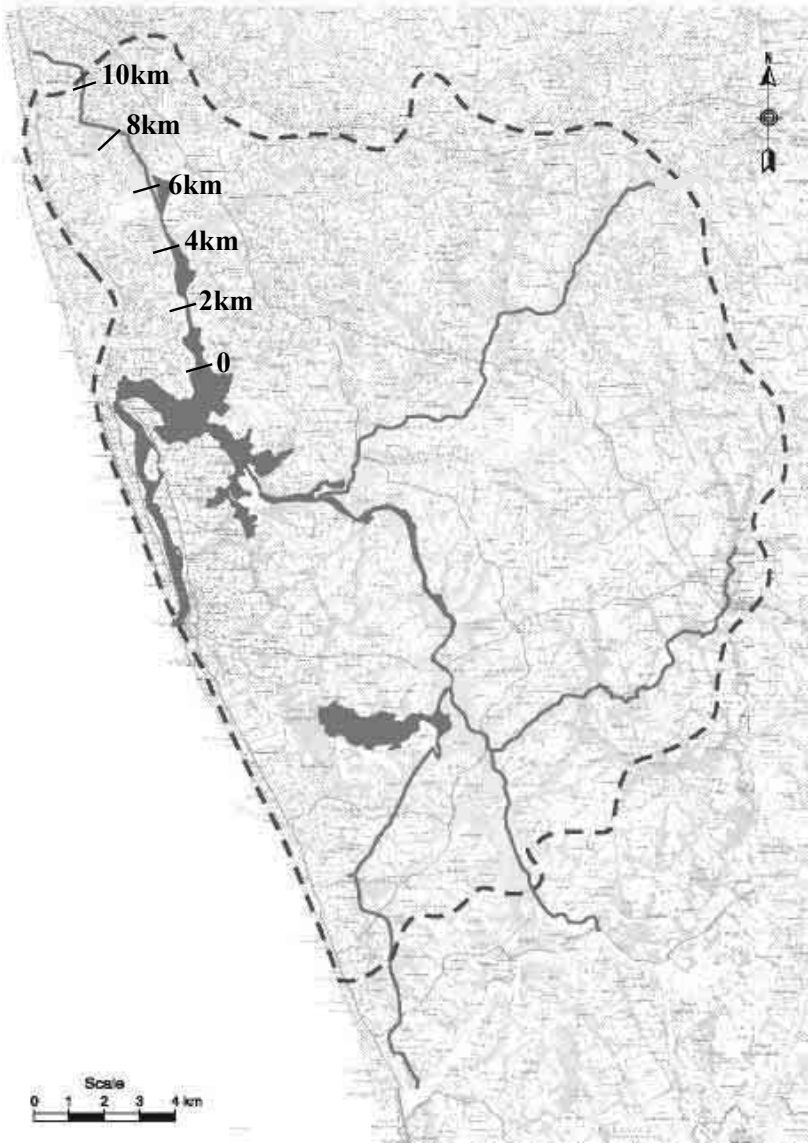

Figure 3.3.4
Longitudinal Profile of Major Stream in
Bolgoda Basin (Maha Oya) (2/7)

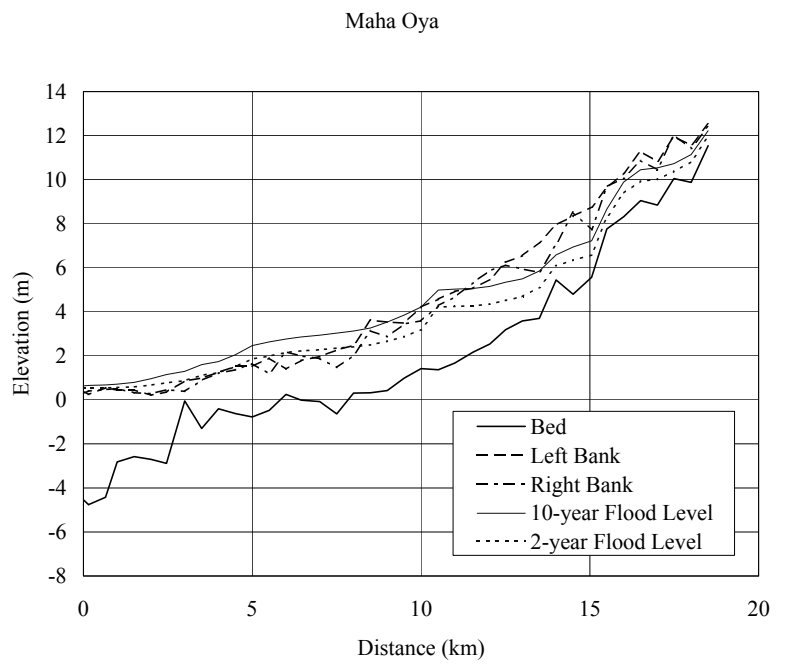
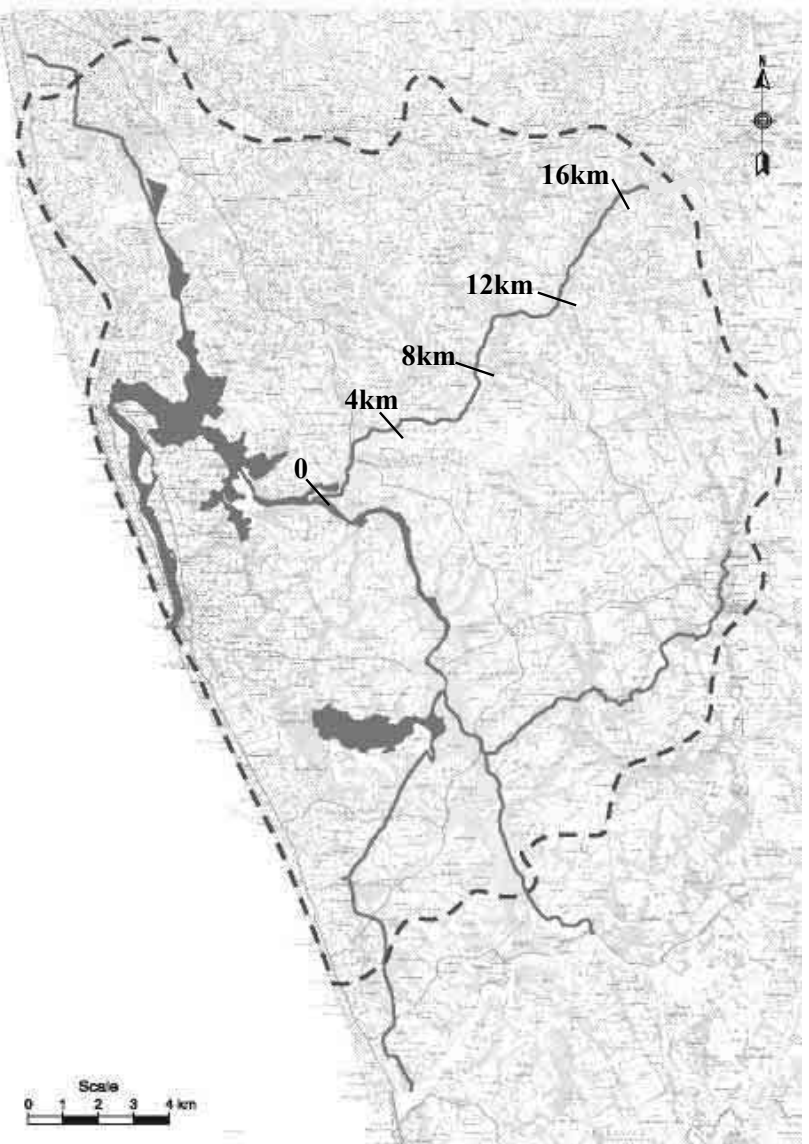

Figure 3.3.4
Longitudinal Profile of Major Stream in
Bolgoda Basin (Bolgoda Ganga) (3/7)

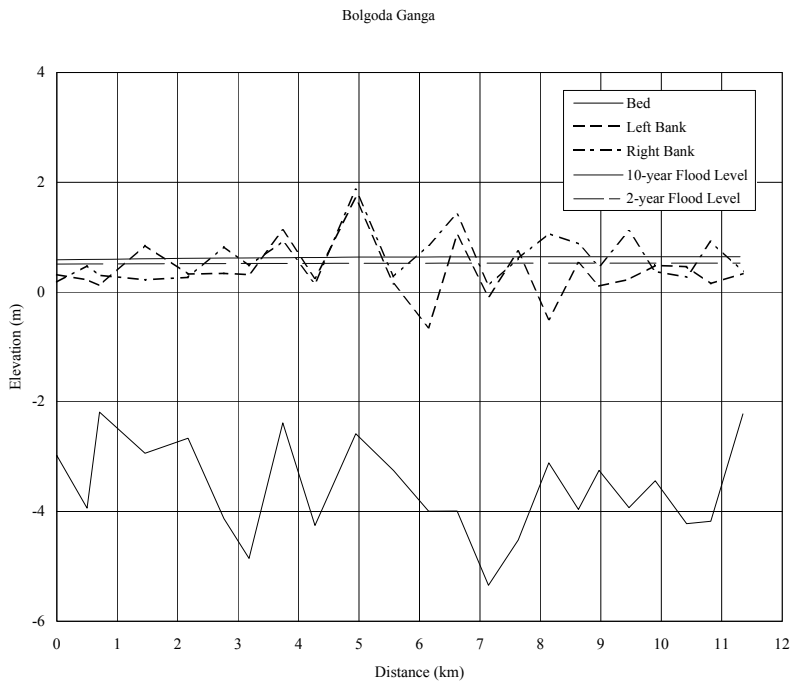
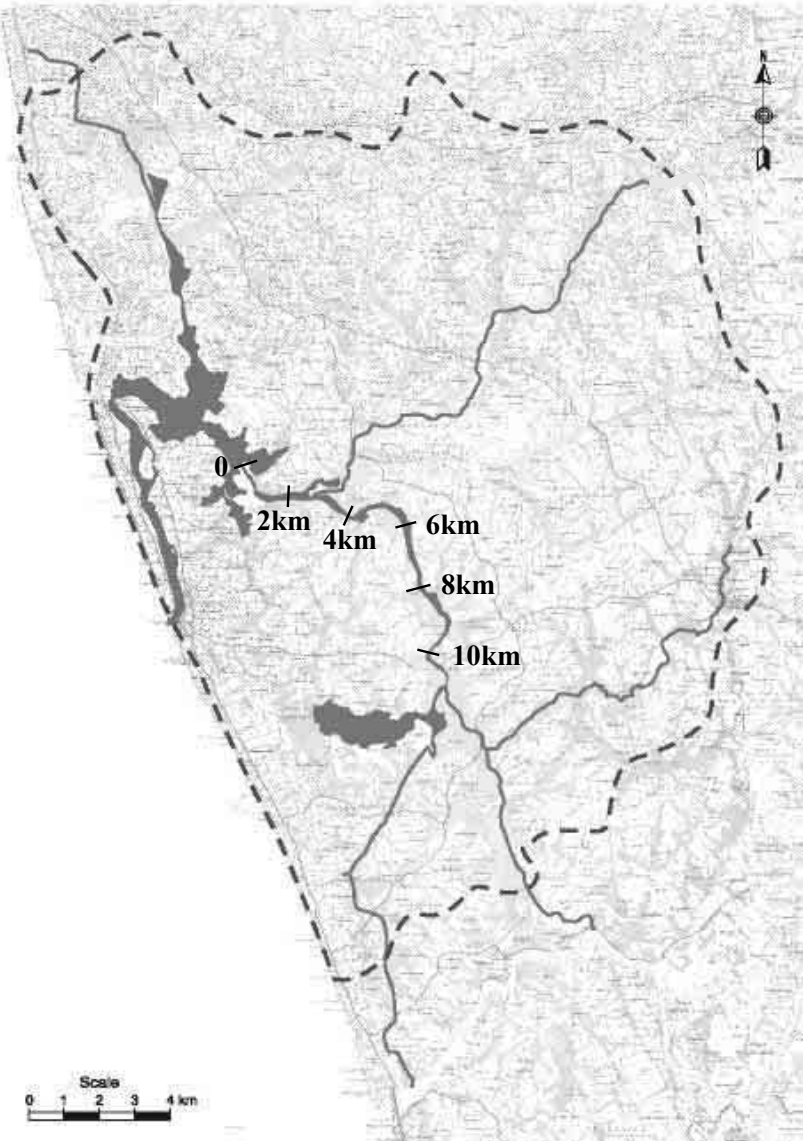
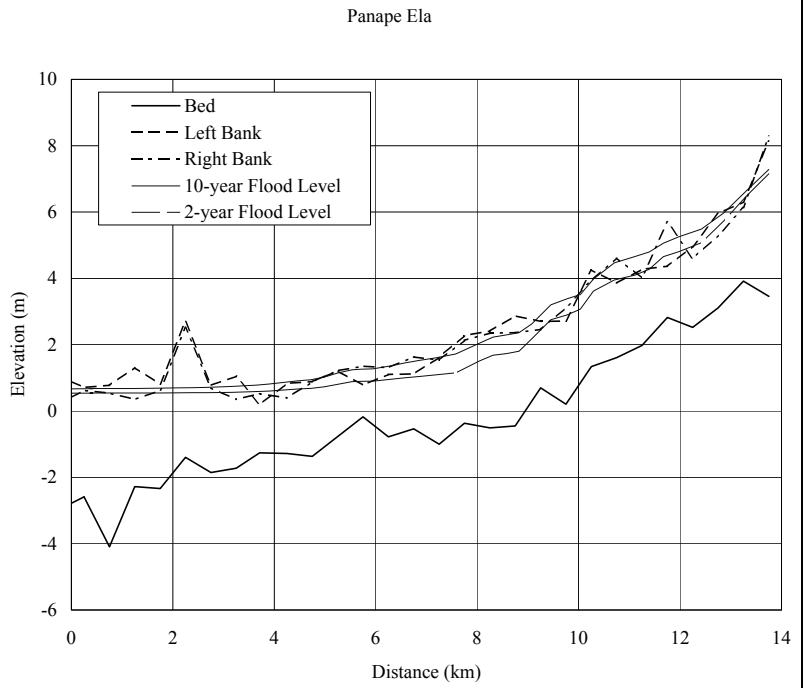
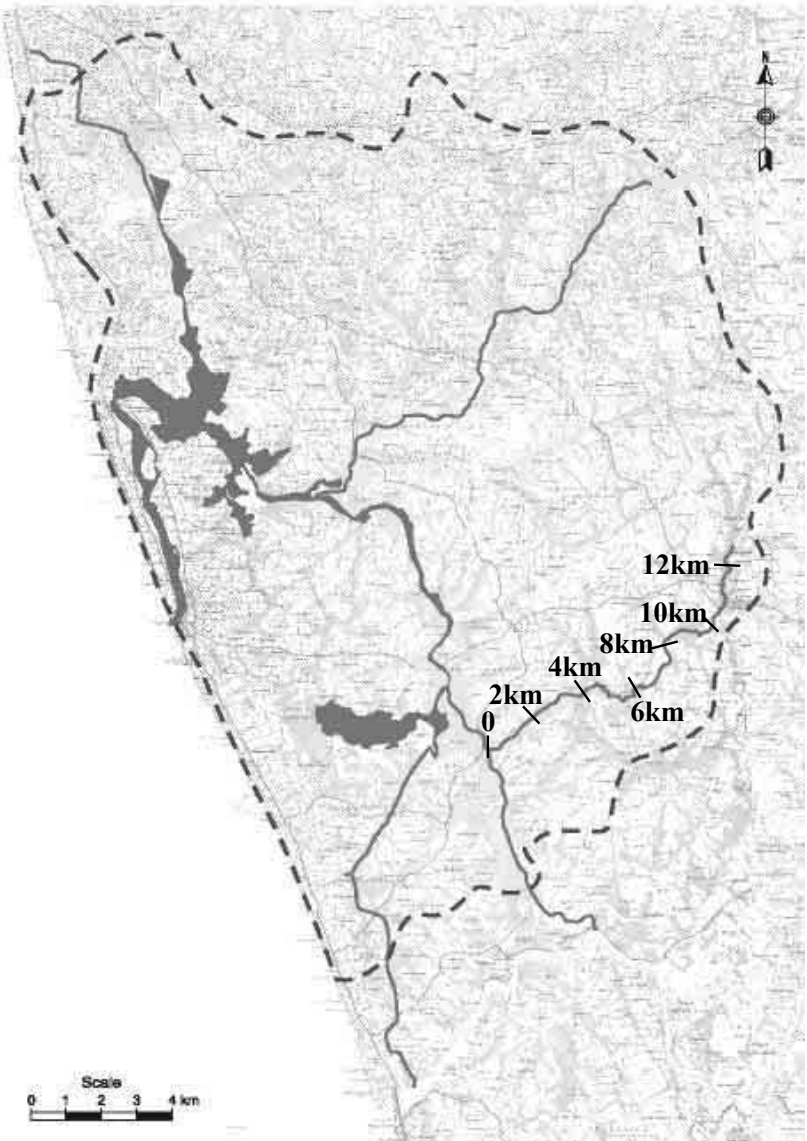
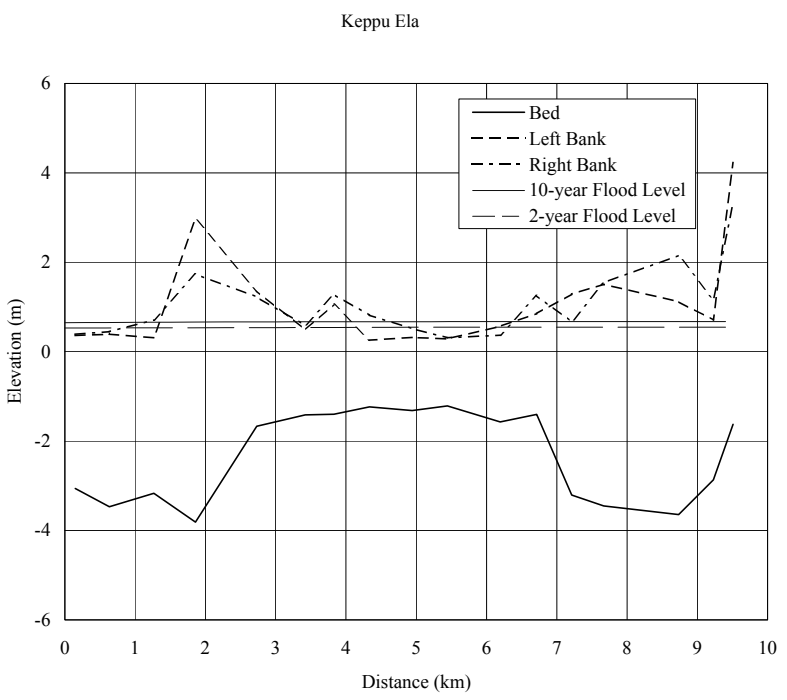
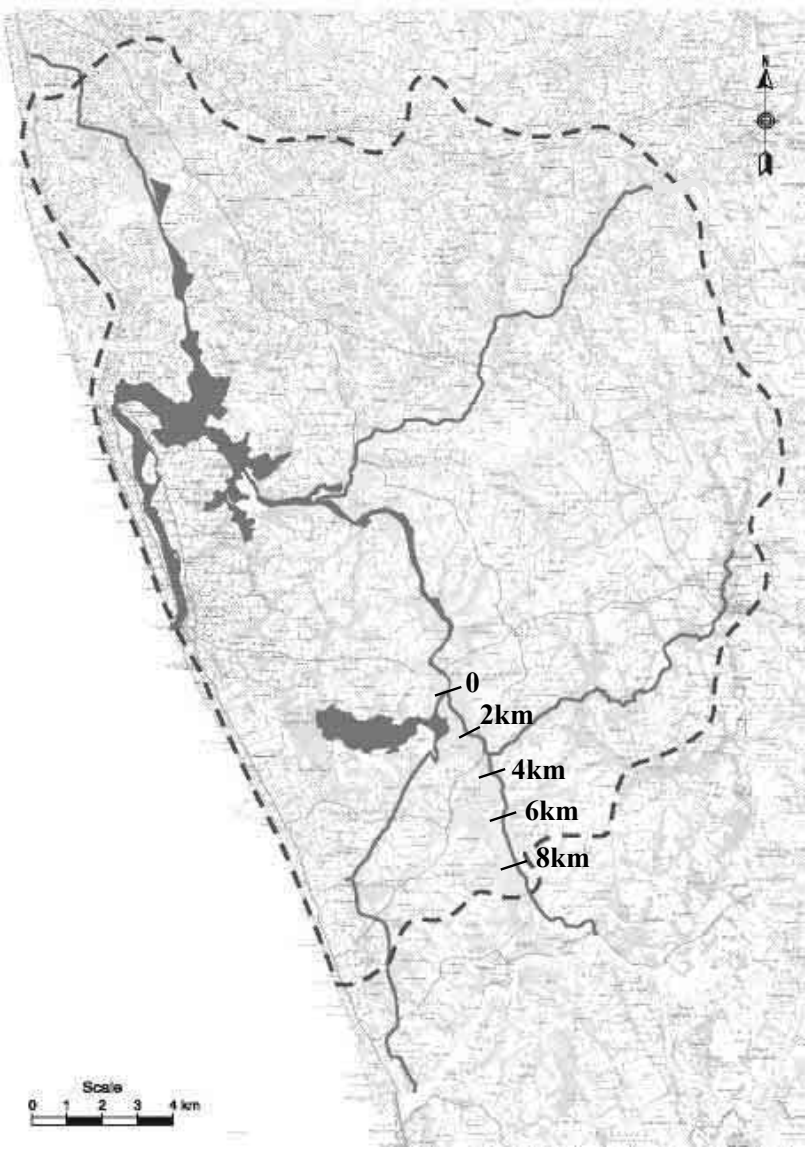

Figure 3.3.4
Longitudinal Profile of Major Stream in
Bolgoda Basin (Panape Ela) (4/7)





*The Study on Storm Water Drainage Plan
for the Colombo Metropolitan Region
in the Democratic Socialist Republic of Sri Lanka*

JAPAN INTERNATIONAL COOPERATION AGENCY

Figure 3.3.4
Longitudinal Profile of Major Stream in
Bolgoda Basin (Keppu Ela) (5/7)

Figure 3.3.4
Longitudinal Profile of Major Stream in
Bolgoda Basin (Alut Ela) (6/7)

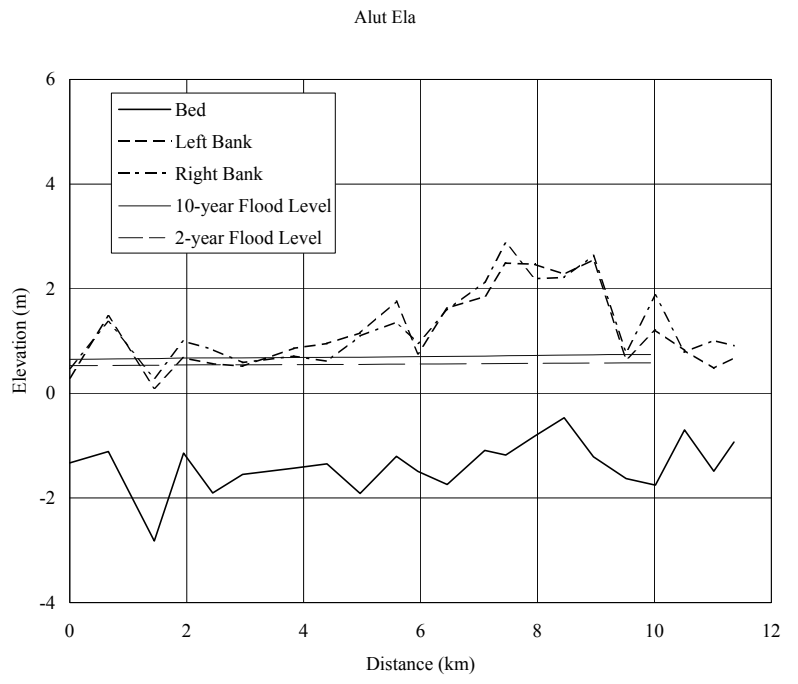
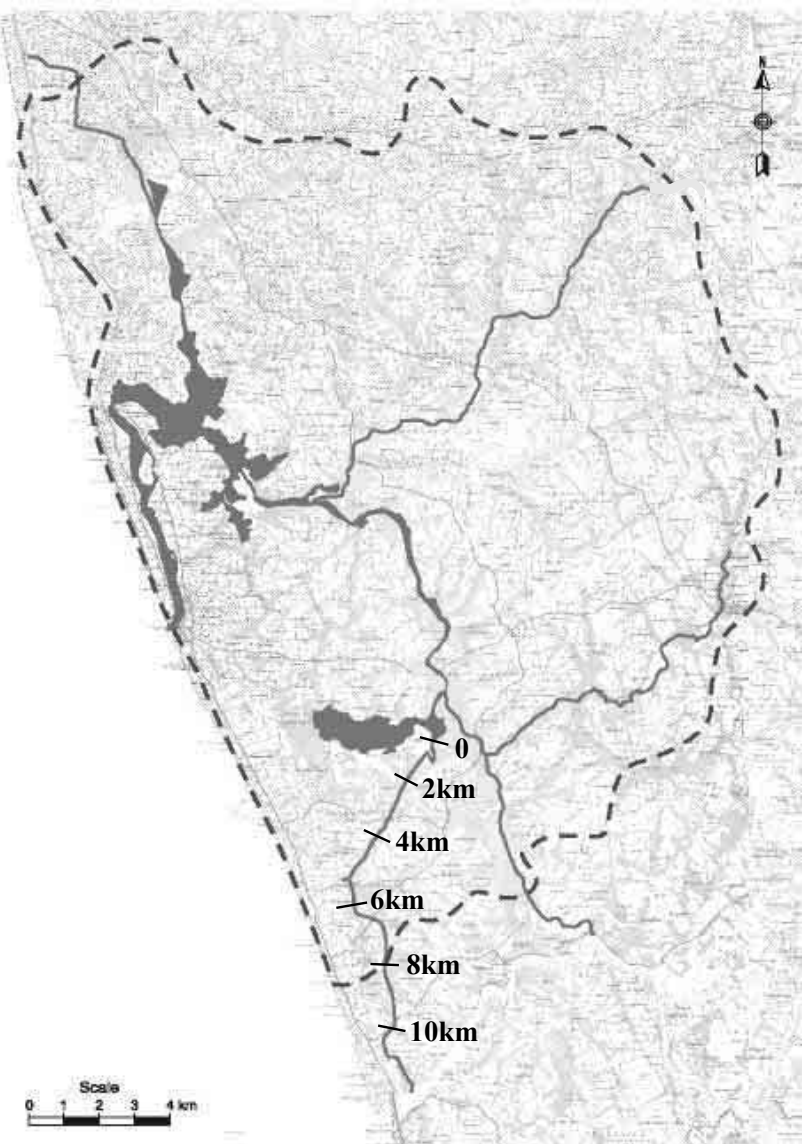

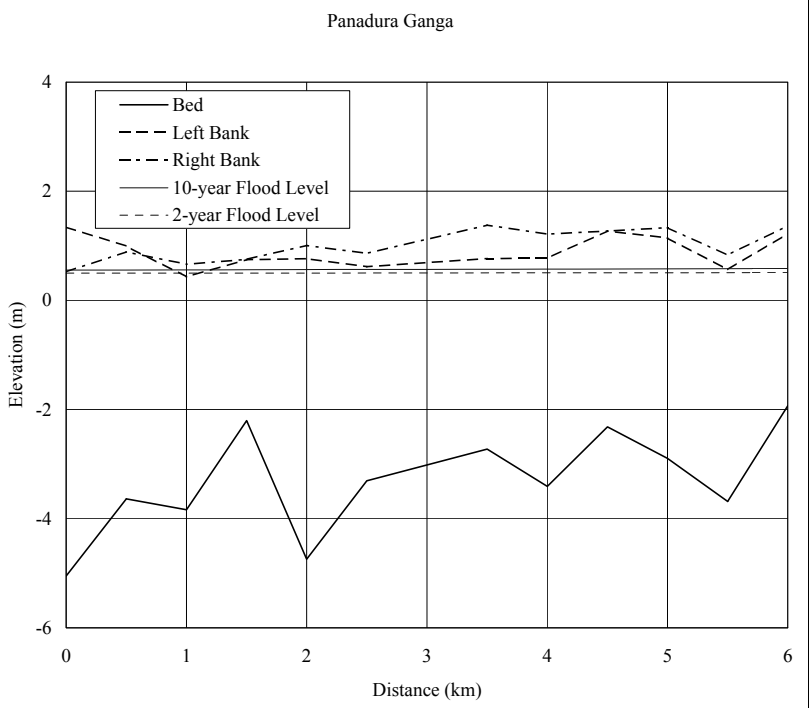
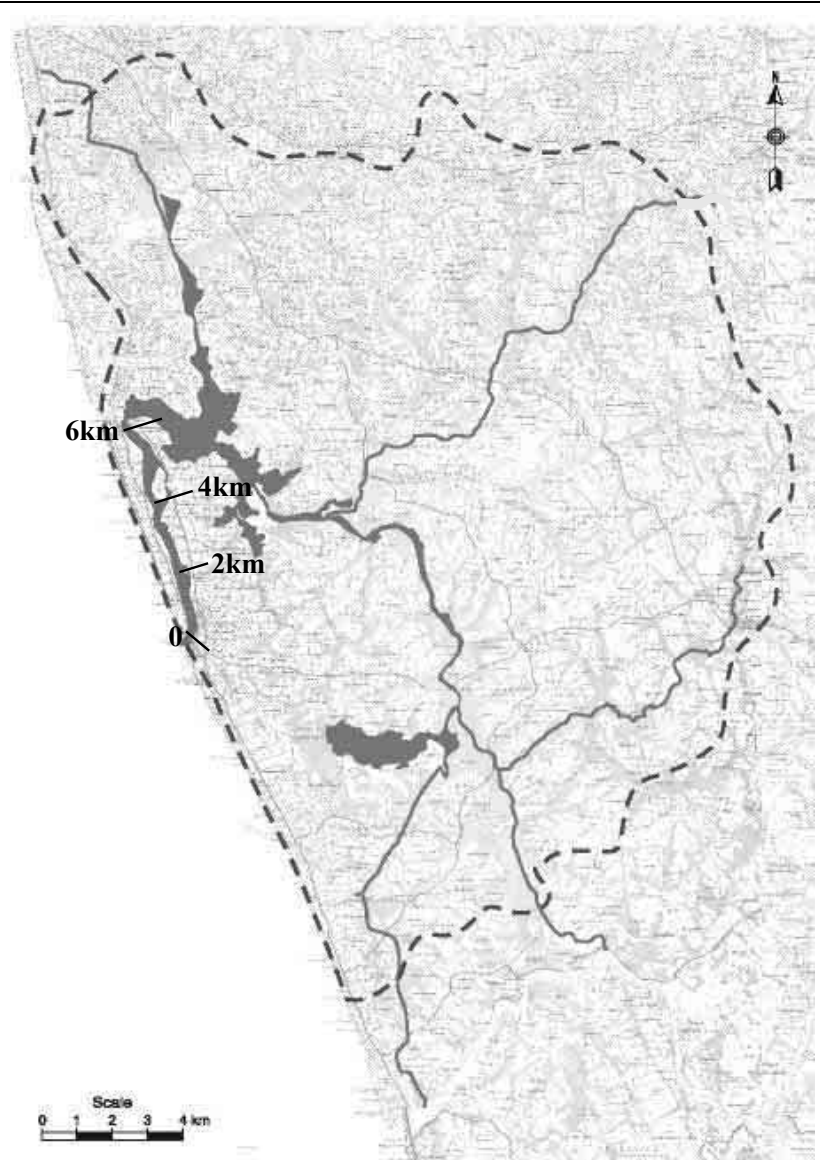

Figure 5.2.1
Diagram of Basic Flood Runoff Distribution
in the Ja Ela Basin (10-year Return Period)

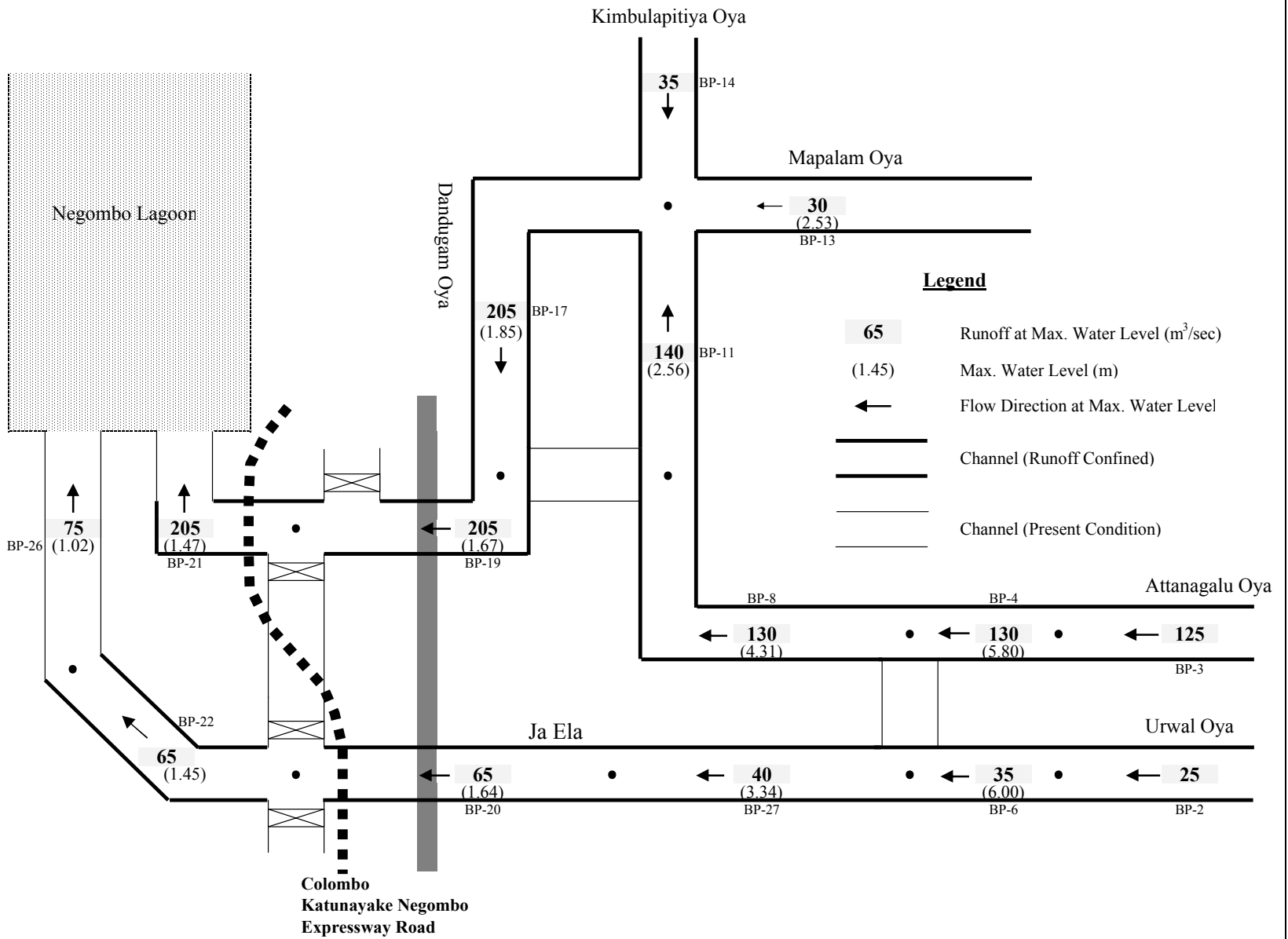

Figure 5.2.2
Diagram of Basic Flood Runoff Distribution
in the Ja Ela Basin (25-year Return Period)

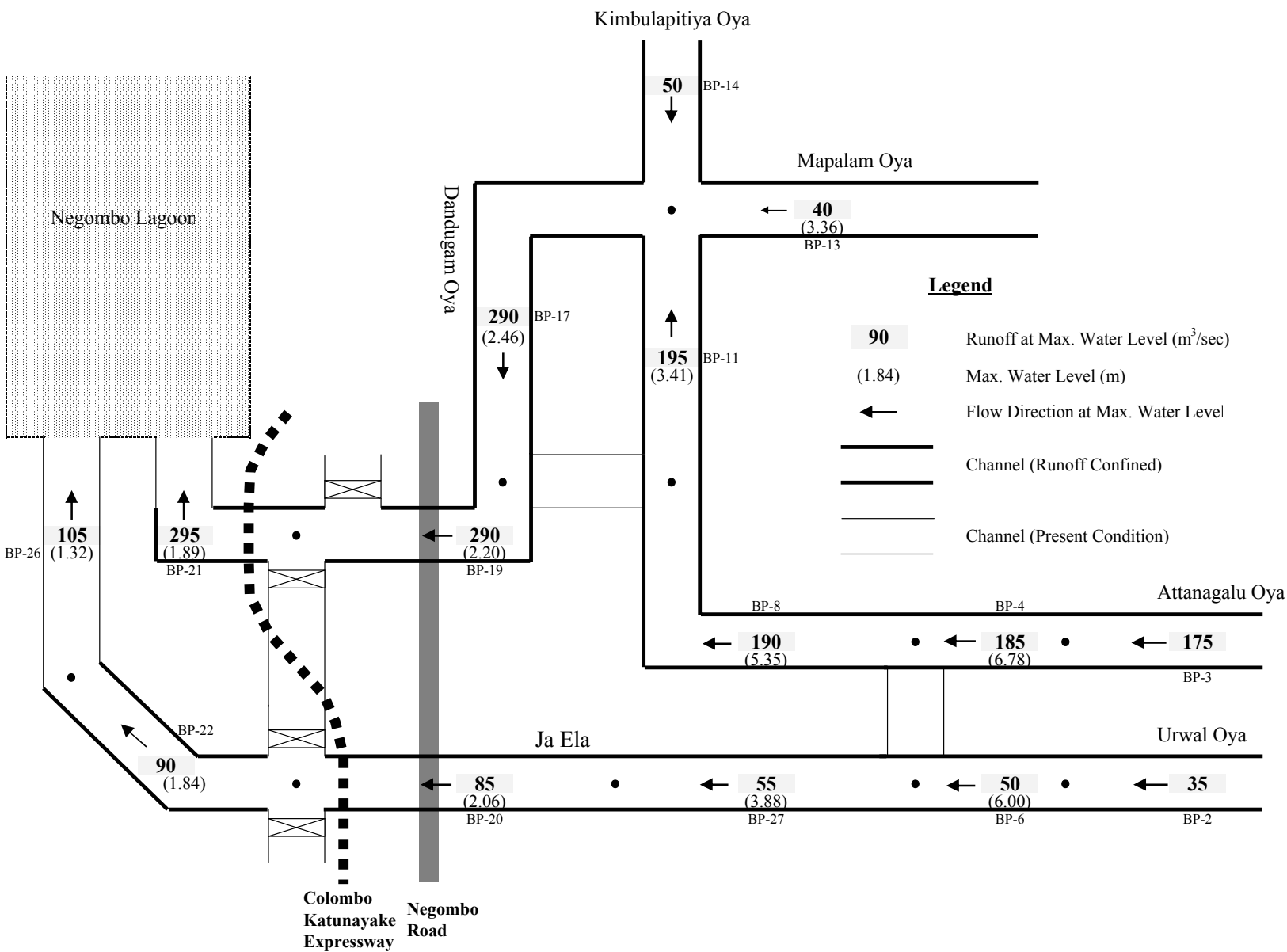

Figure 5.2.3
Diagram of Basic Flood Runoff Distribution
in the Ja Ela Basin (50-year Return Period)

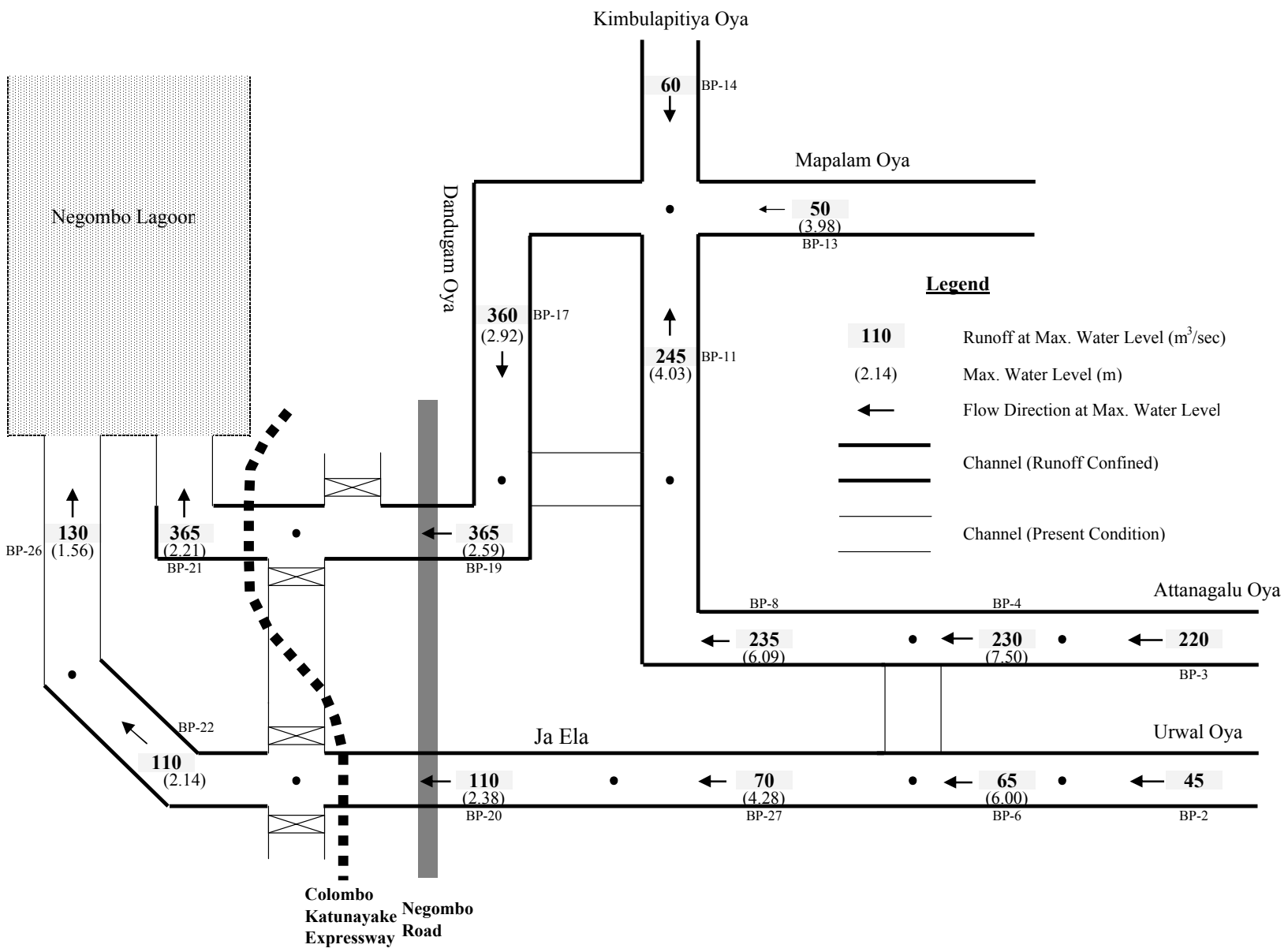

Figure 5.2.4
Diagram of Probable Flood Runoff Distribution
in the Ja Ela Basin (10-year Return Period)

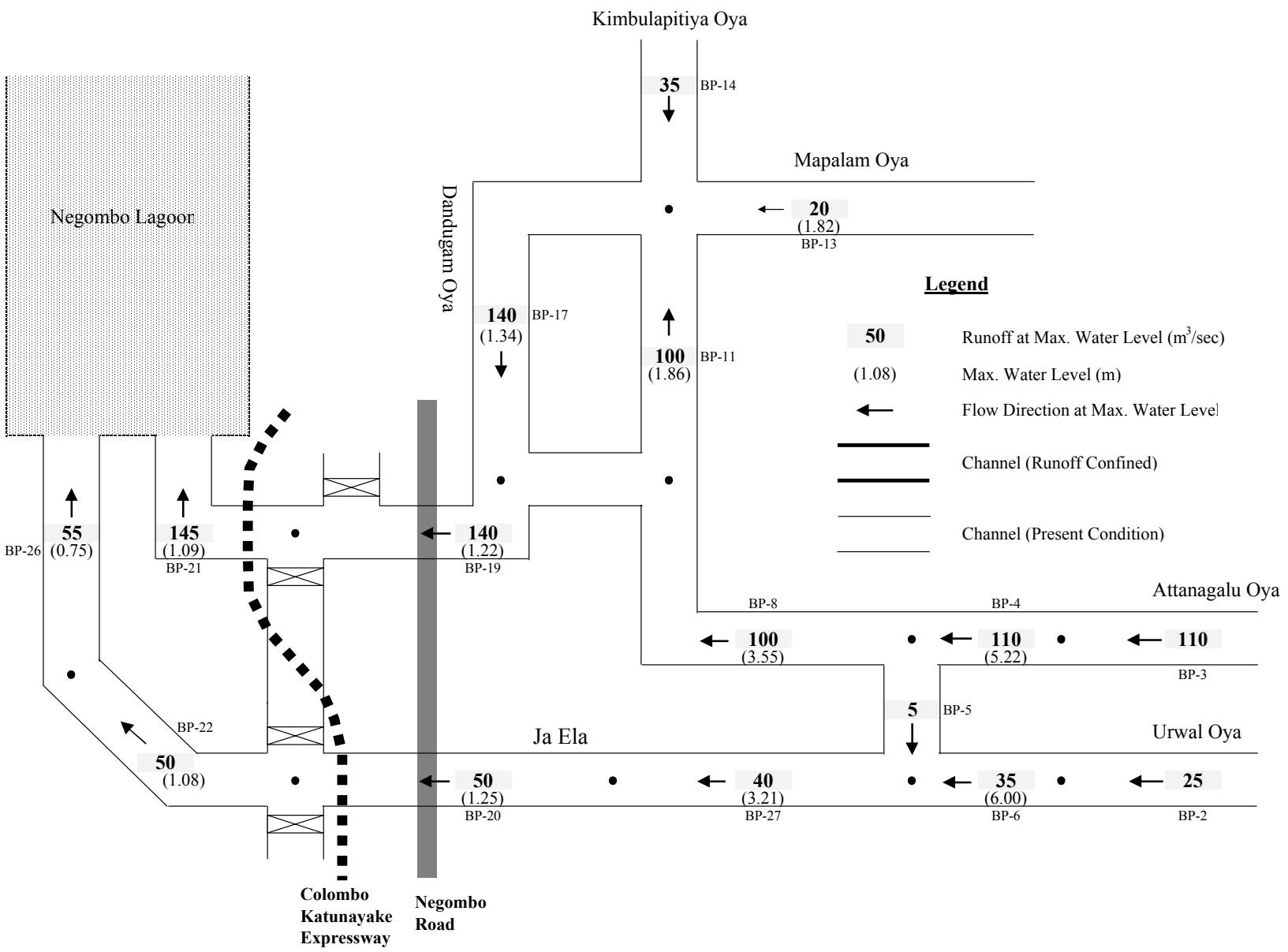

Figure 5.2.5
Diagram of Probable Flood Runoff Distribution
in the Ja Ela Basin (25-year Return Period)

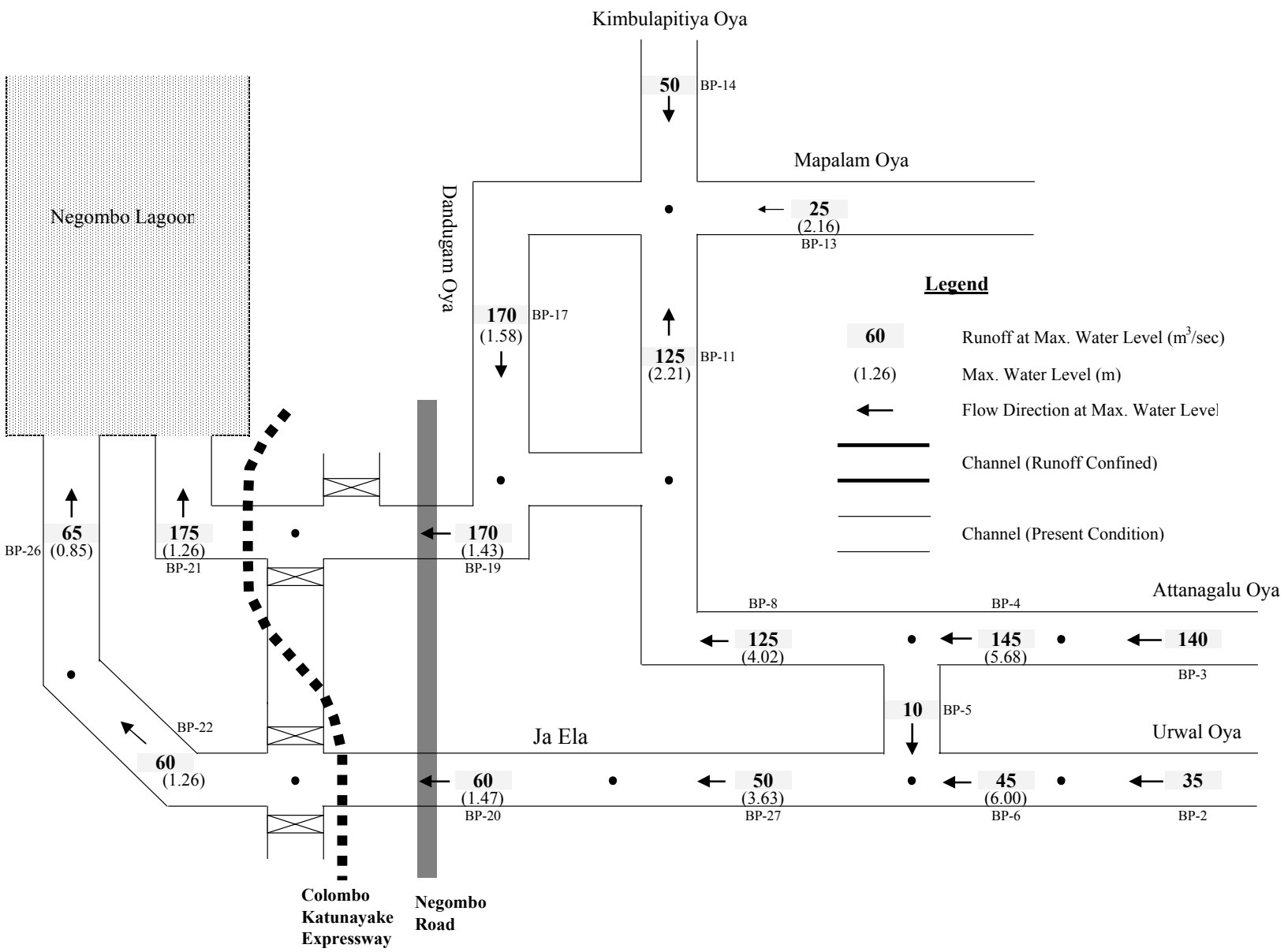
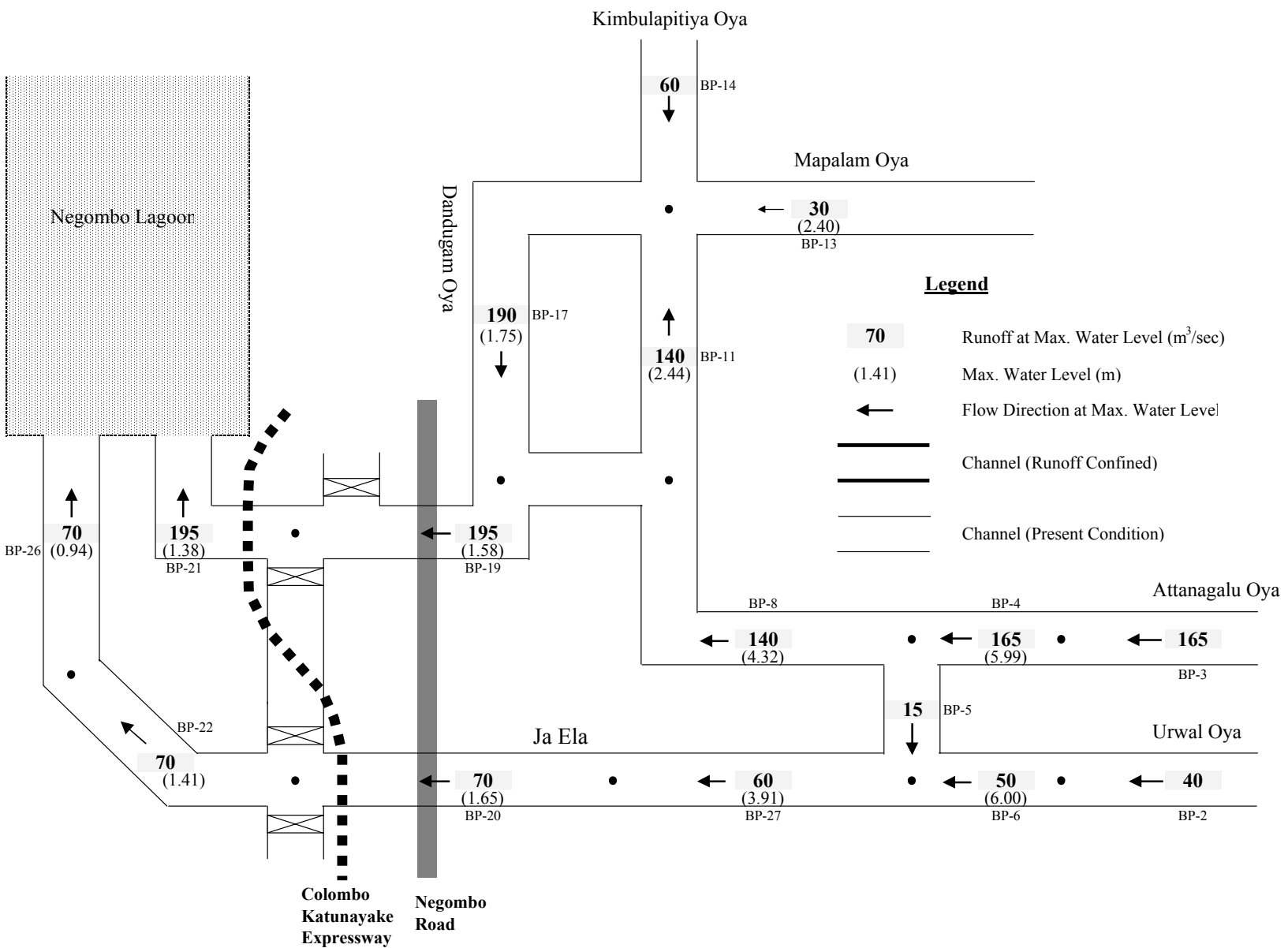
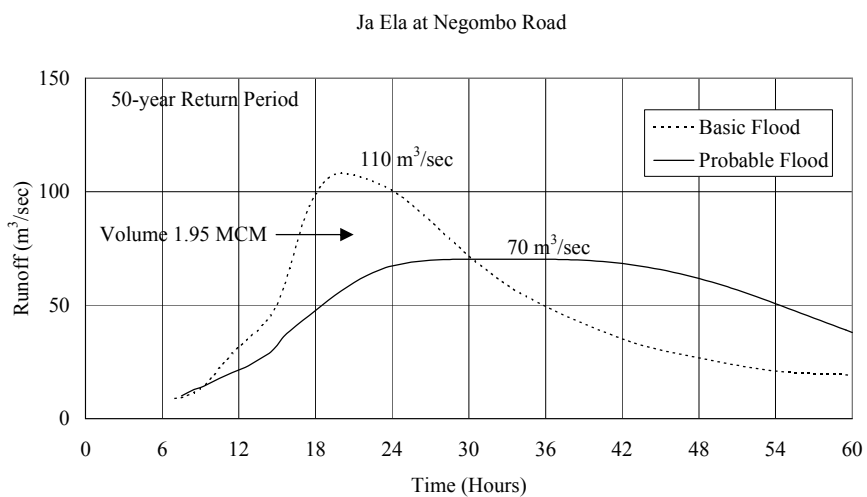
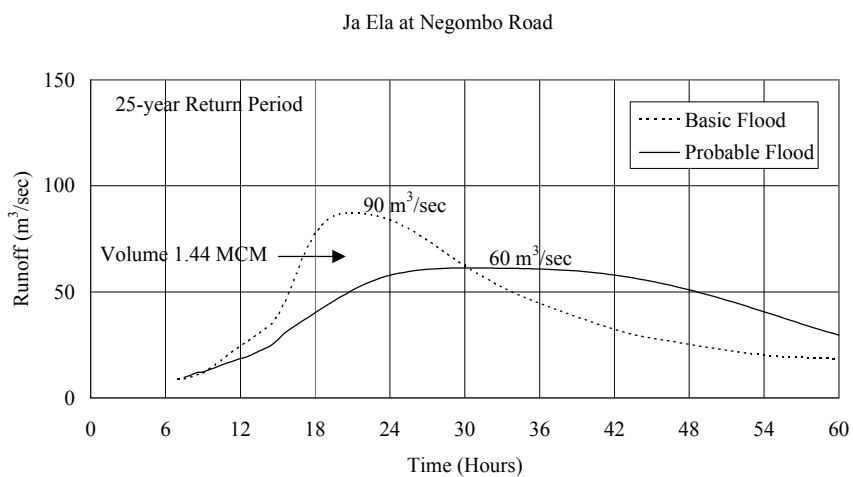
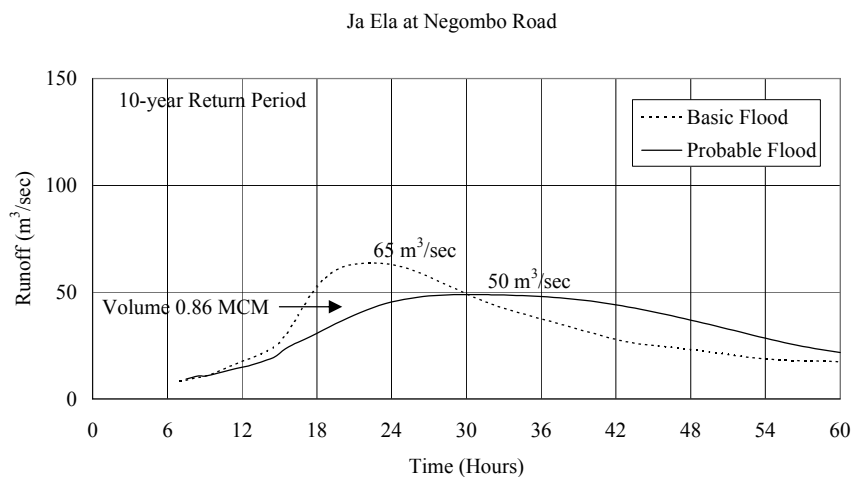

Figure 5.2.6
Diagram of Probable Flood Runoff Distribution
in the Ja Ela Basin (50-year Return Period)





*The Study on Storm Water Drainage Plan
for the Colombo Metropolitan Region
in the Democratic Socialist Republic of Sri Lanka*

JAPAN INTERNATIONAL COOPERATION AGENCY

Figure 5.2.7
Runoff Hydrograph in Ja Ela Basin (1/2)
(Ja Ela at Negombo Road)

Dandugam Oya at Negombo Road

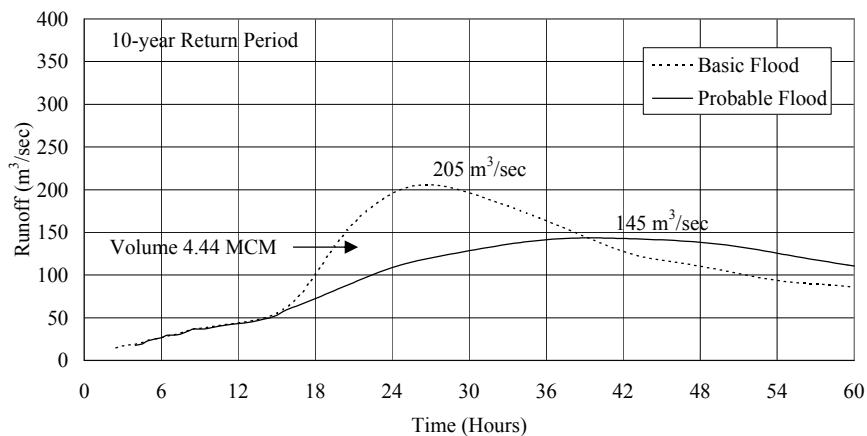

Dandugam Oya at Negombo Road

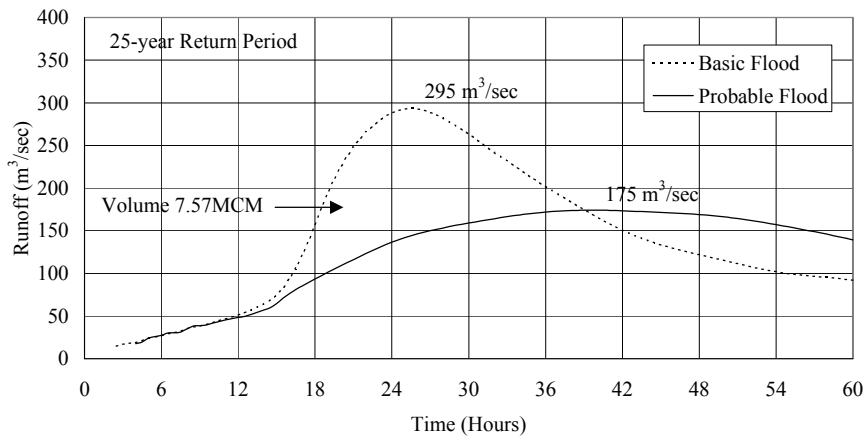

Dandugam Oya at Negombo Road

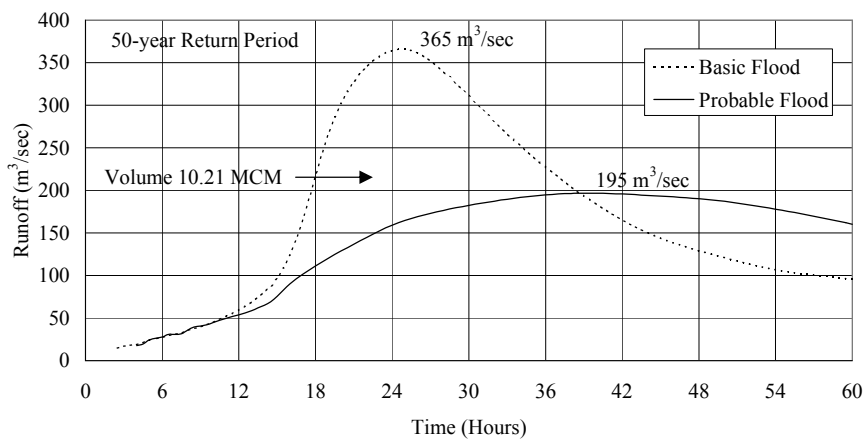

The Study on Storm Water Drainage Plan
for the Colombo Metropolitan Region
in the Democratic Socialist Republic of Sri Lanka

JAPAN INTERNATIONAL COOPERATION AGENCY

Figure 5.2.7
Runoff Hydrograph in Ja Ela Basin (2/2)
(Dandugam Oya at Negombo Road)

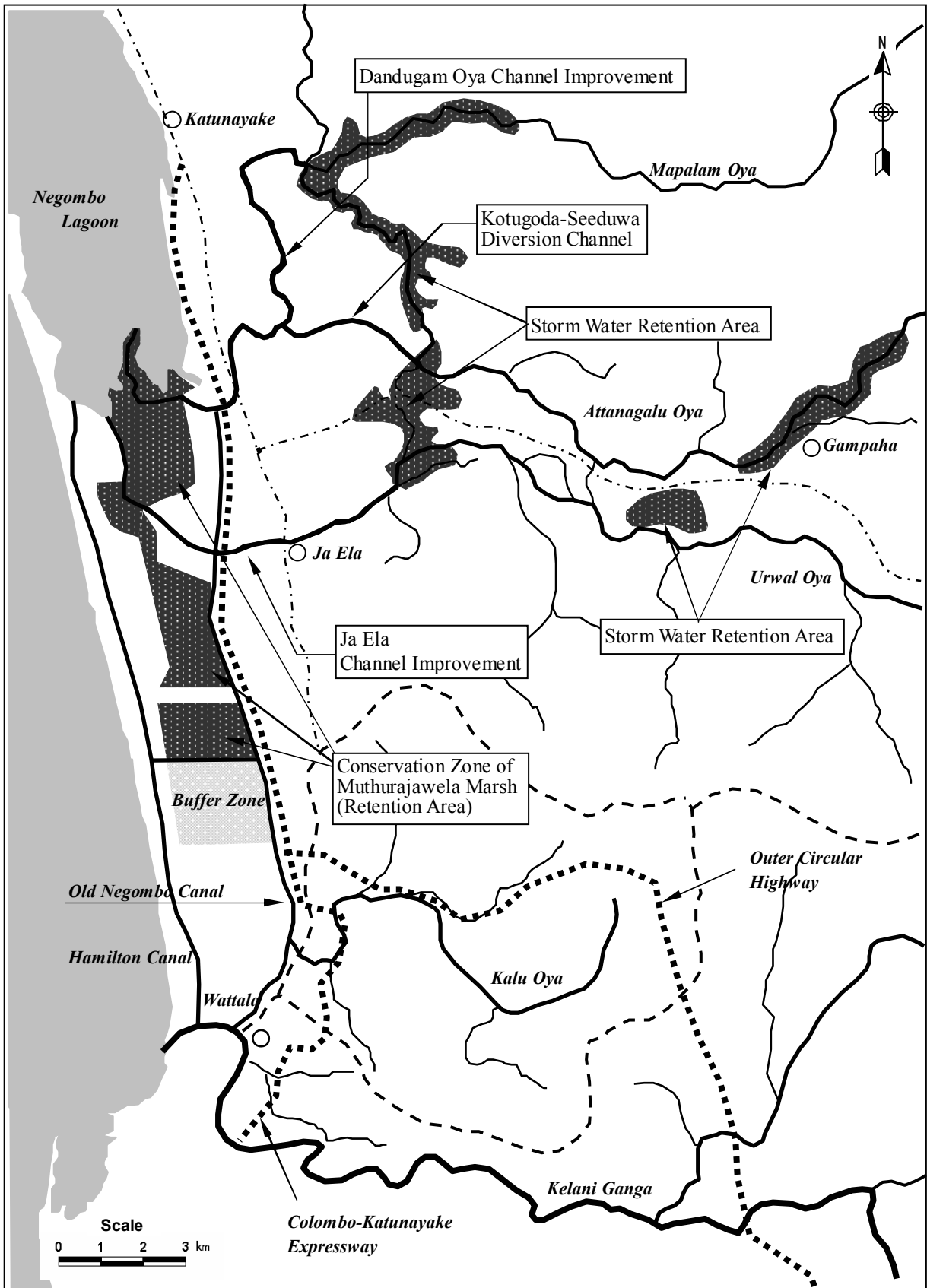

*The Study on Storm Water Drainage Plan
for the Colombo Metropolitan Region
in the Democratic Socialist Republic of Sri Lanka*
JAPAN INTERNATIONAL COOPERATION AGENCY

Figure 5.3.1
Conceivable Structural Measures for
Ja Ela Basin



*The Study on Storm Water Drainage Plan
for the Colombo Metropolitan Region
in the Democratic Socialist Republic of Sri Lanka*

JAPAN INTERNATIONAL COOPERATION AGENCY

Figure 5.3.2
General Plan of Dandugam Oya Channel Improvement

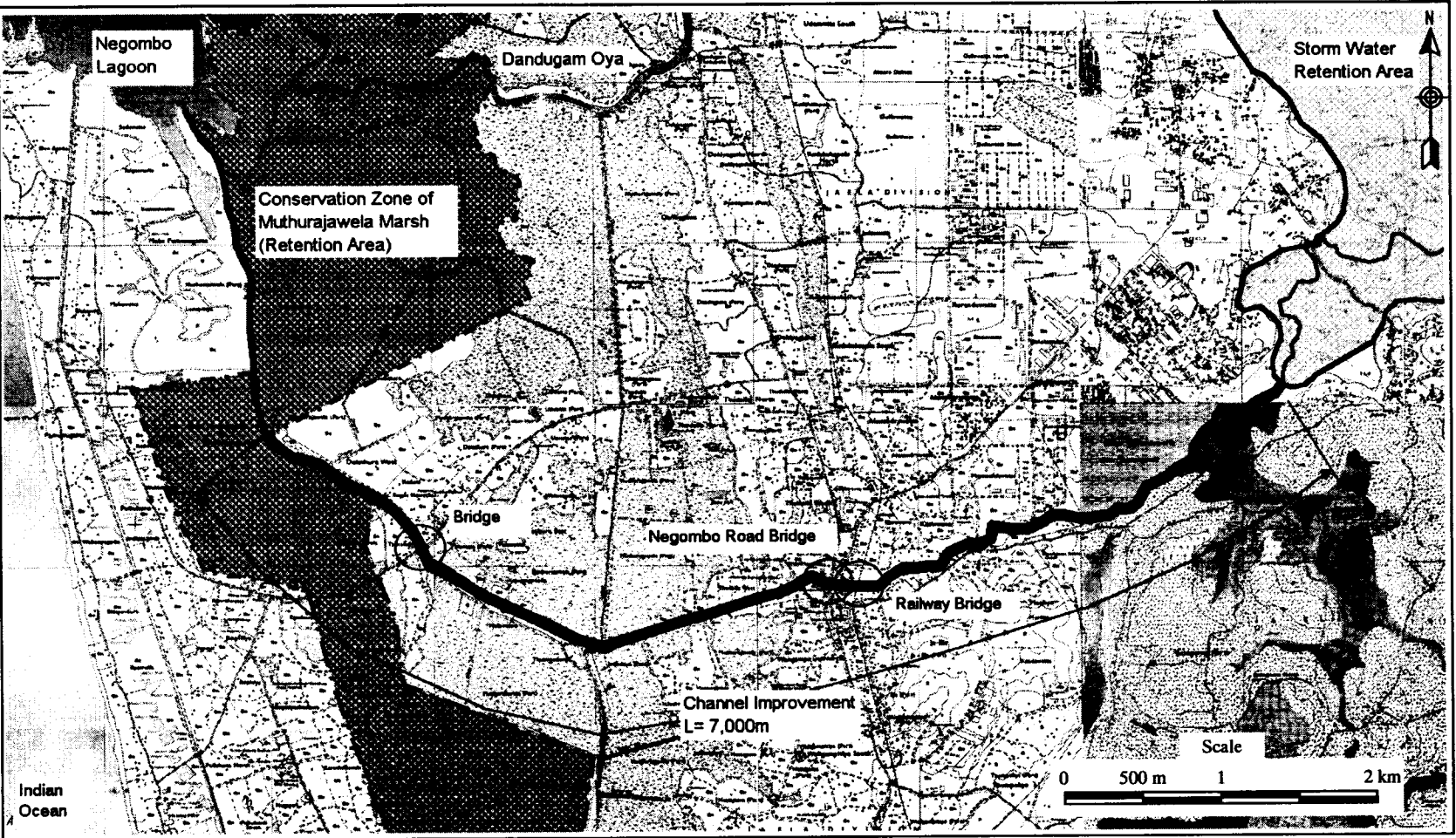

*The Study on Storm Water Drainage Plan
for the Colombo Metropolitan Region
in the Democratic Socialist Republic of Sri Lanka*
JAPAN INTERNATIONAL COOPERATION AGENCY

Figure 5.3.3
General Plan of Ja Ela Channel Improvement

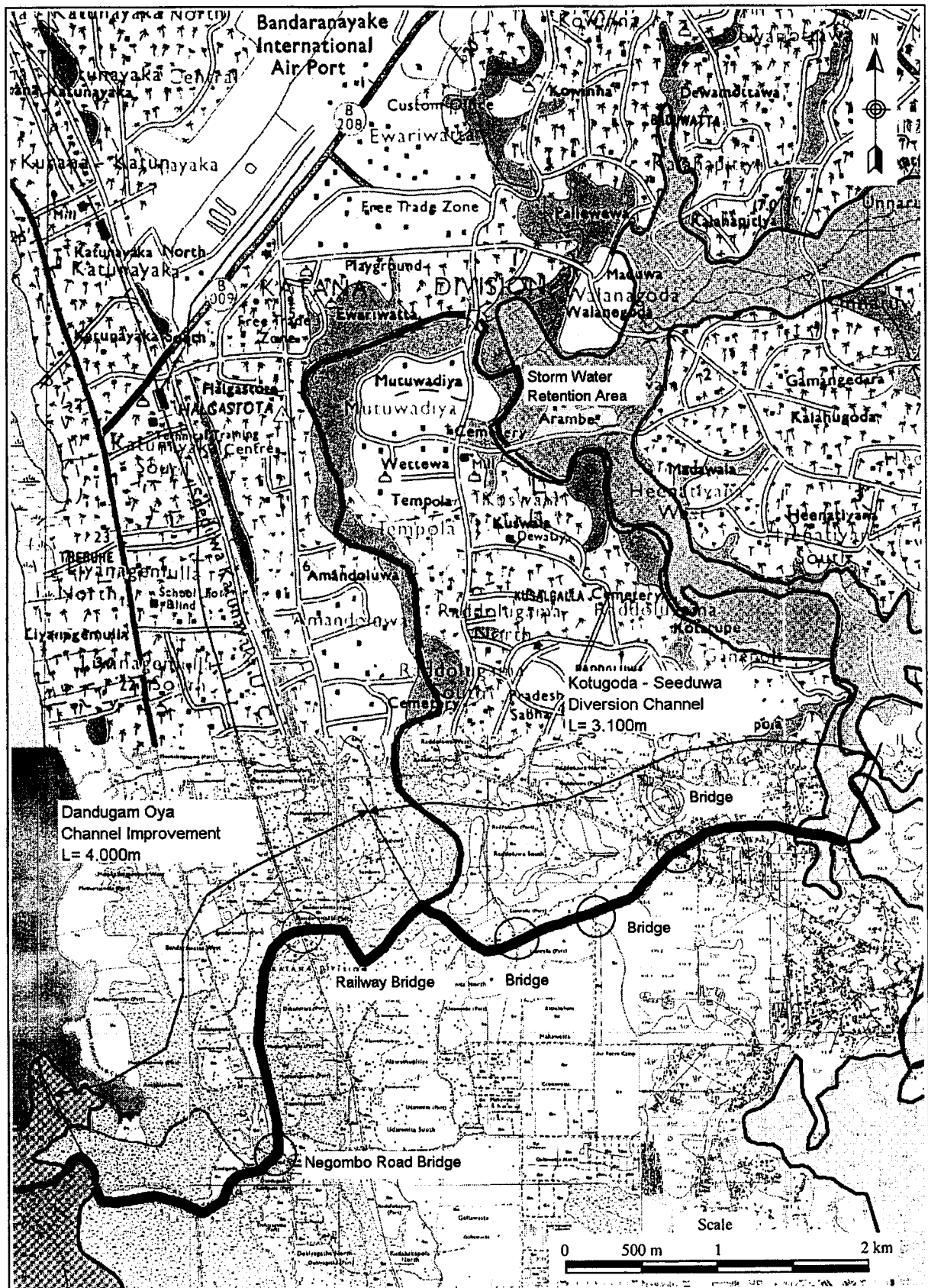

*The Study on Storm Water Drainage Plan
for the Colombo Metropolitan Region
in the Democratic Socialist Republic of Sri Lanka*
JAPAN INTERNATIONAL COOPERATION AGENCY

Figure 5.3.4
General Plan of Kotugoda-Seeduwa Diversion Channel