

KEY MAP

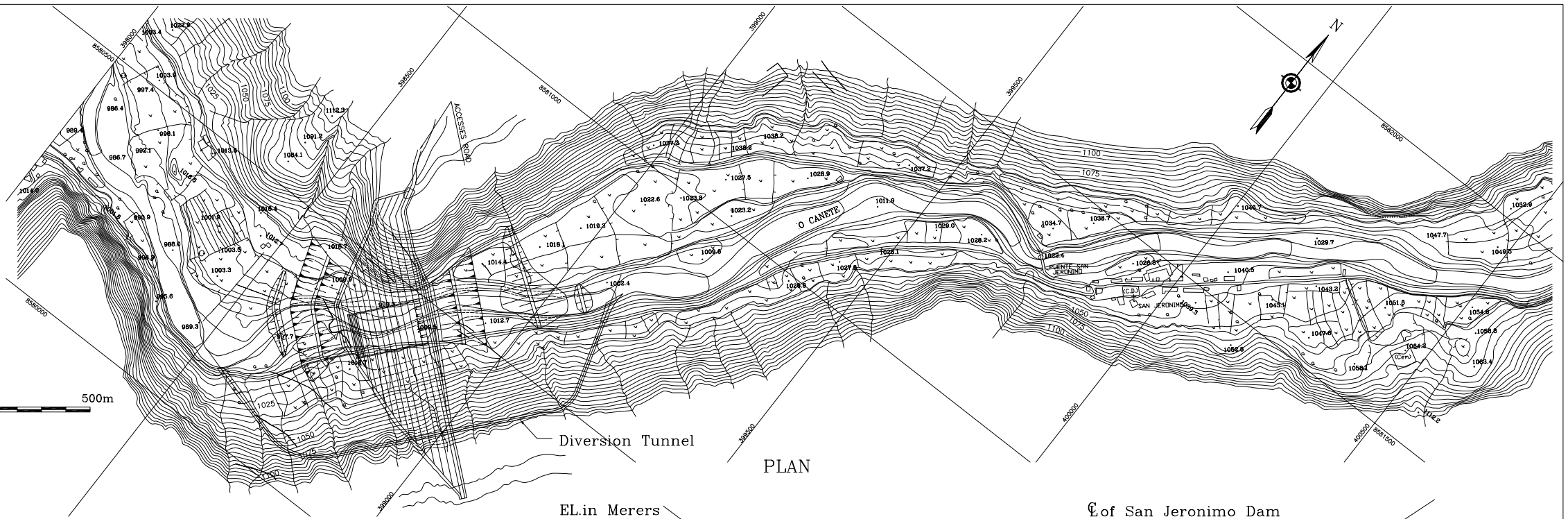

PLAN

EL.in Merers

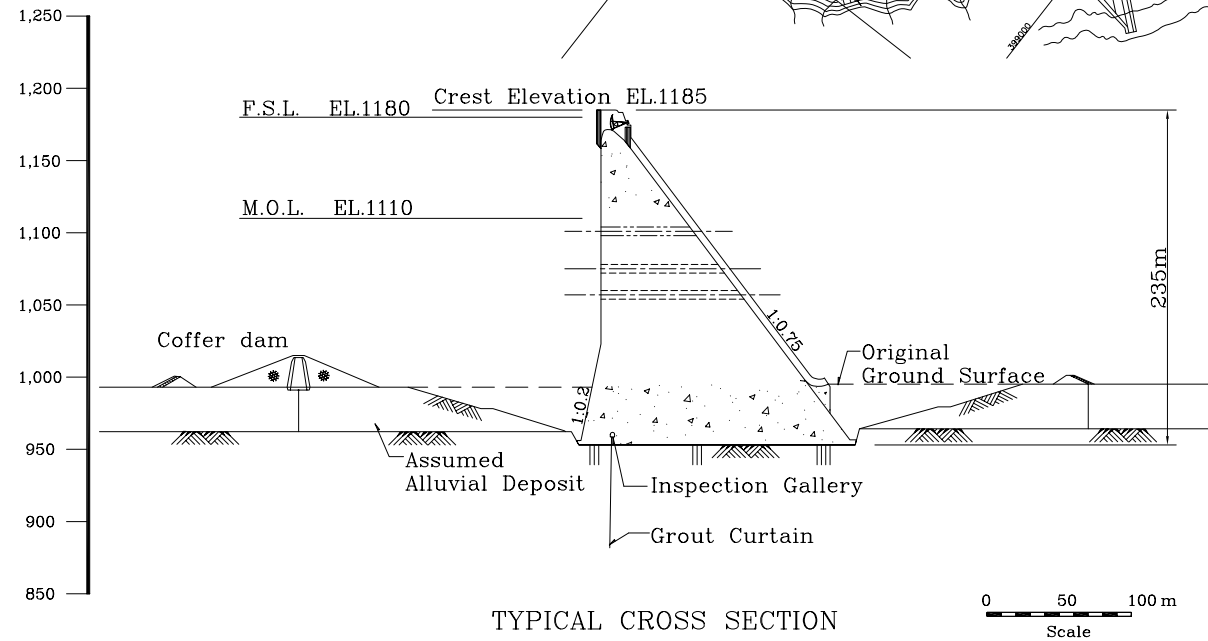

TYPICAL CROSS SECTION

EL.in Merers

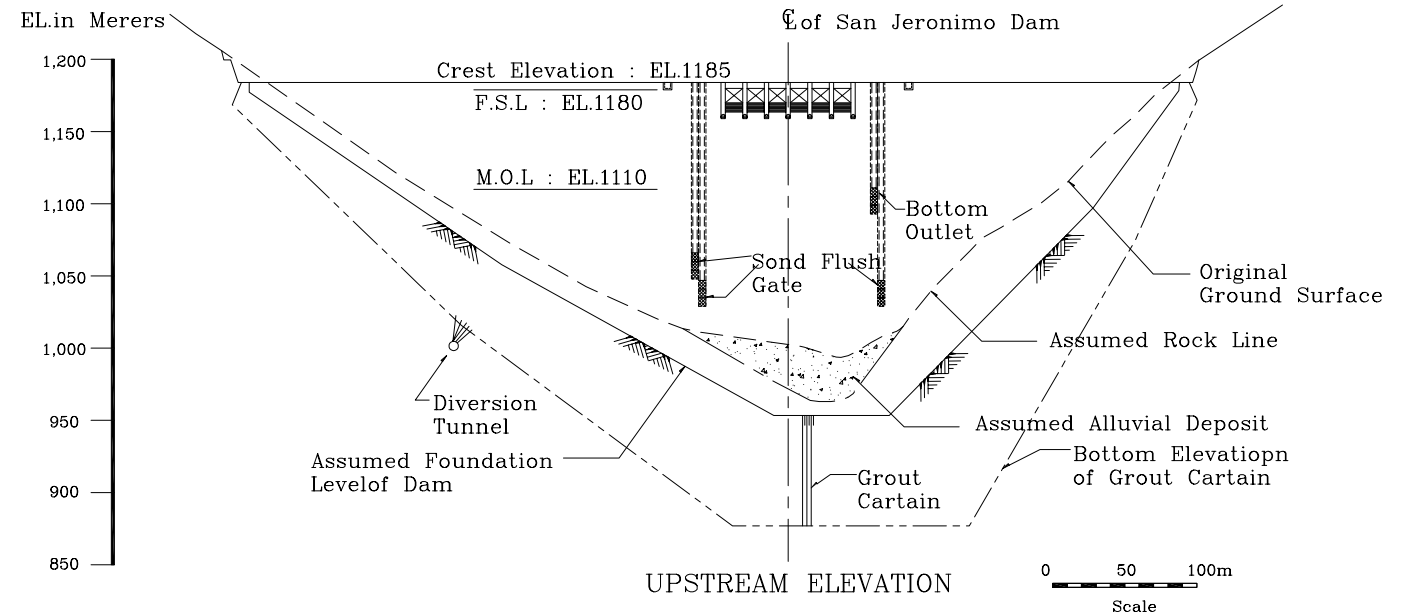

UPSTREAM ELEVATION

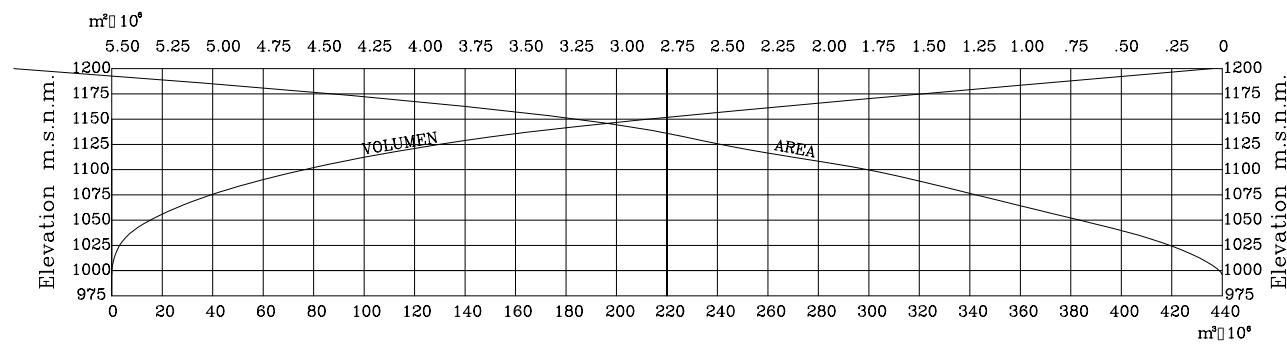

SAN JERONIMO DAM AREA - CAPACITY CURVE

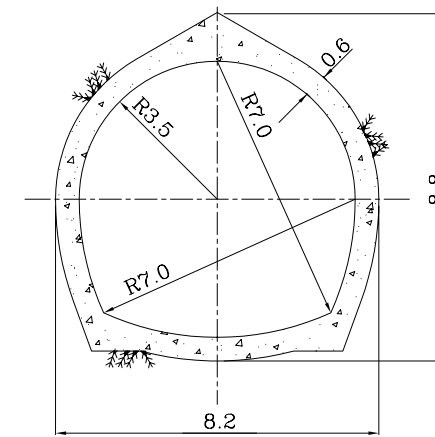

TYPICAL SECTION OF DIVERSION TUNNEL

STUDY ON INTEGRATED WATER RESOURCES DEVELOPMENT
 THE CANETE RIVER BASIN IN THE REPUBLIC OF PERU
 JAPAN INTERNATIONAL COOPERATION AGENCY

Figura 5.1.6

Presa San Jeronimo (Presa RCC)

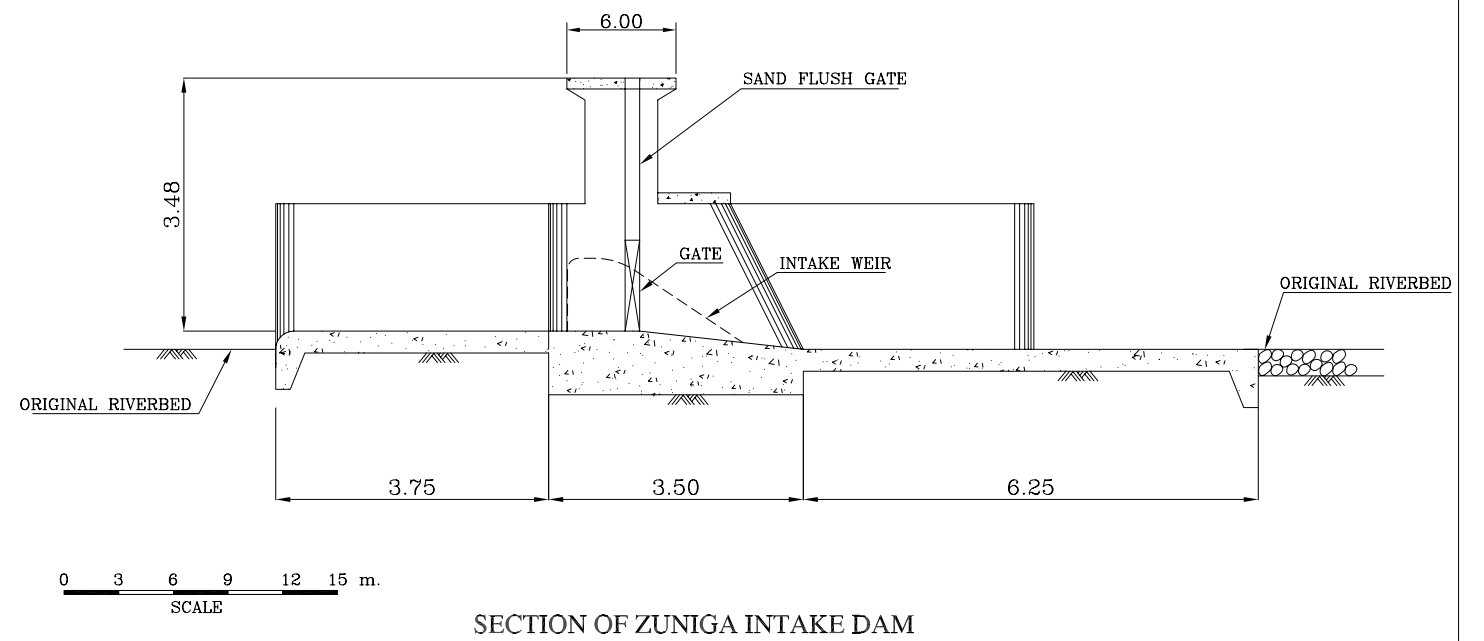
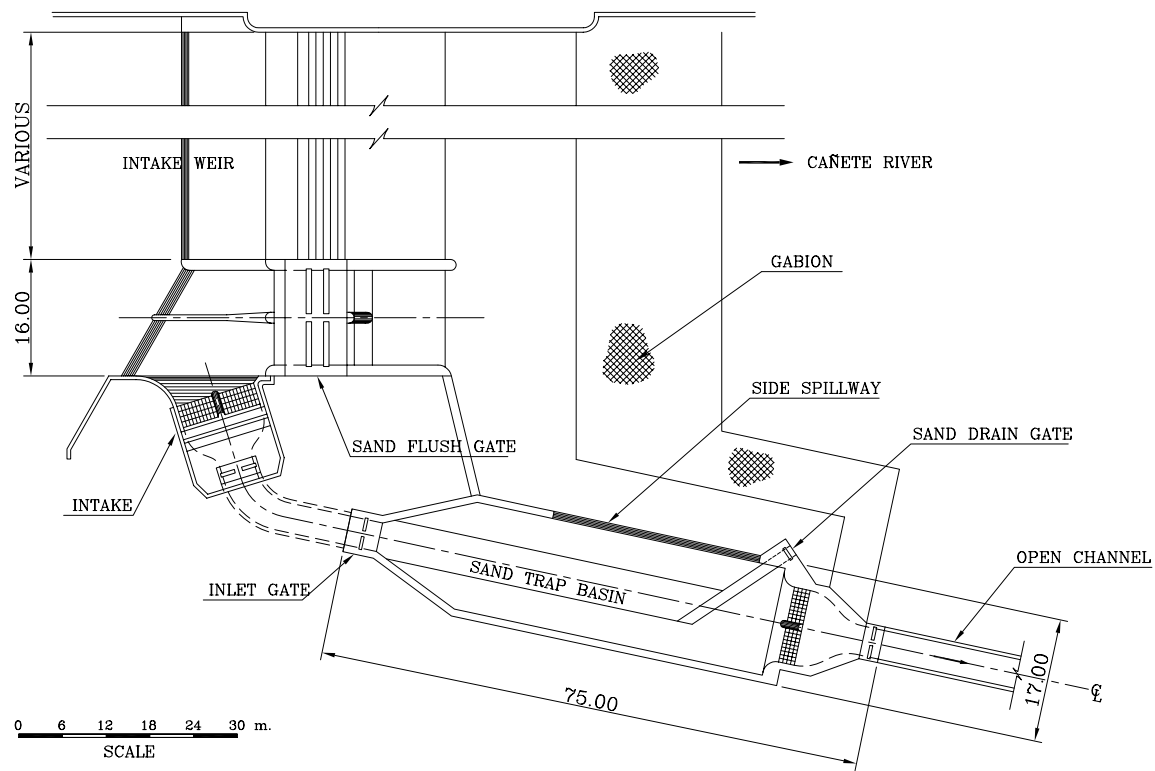
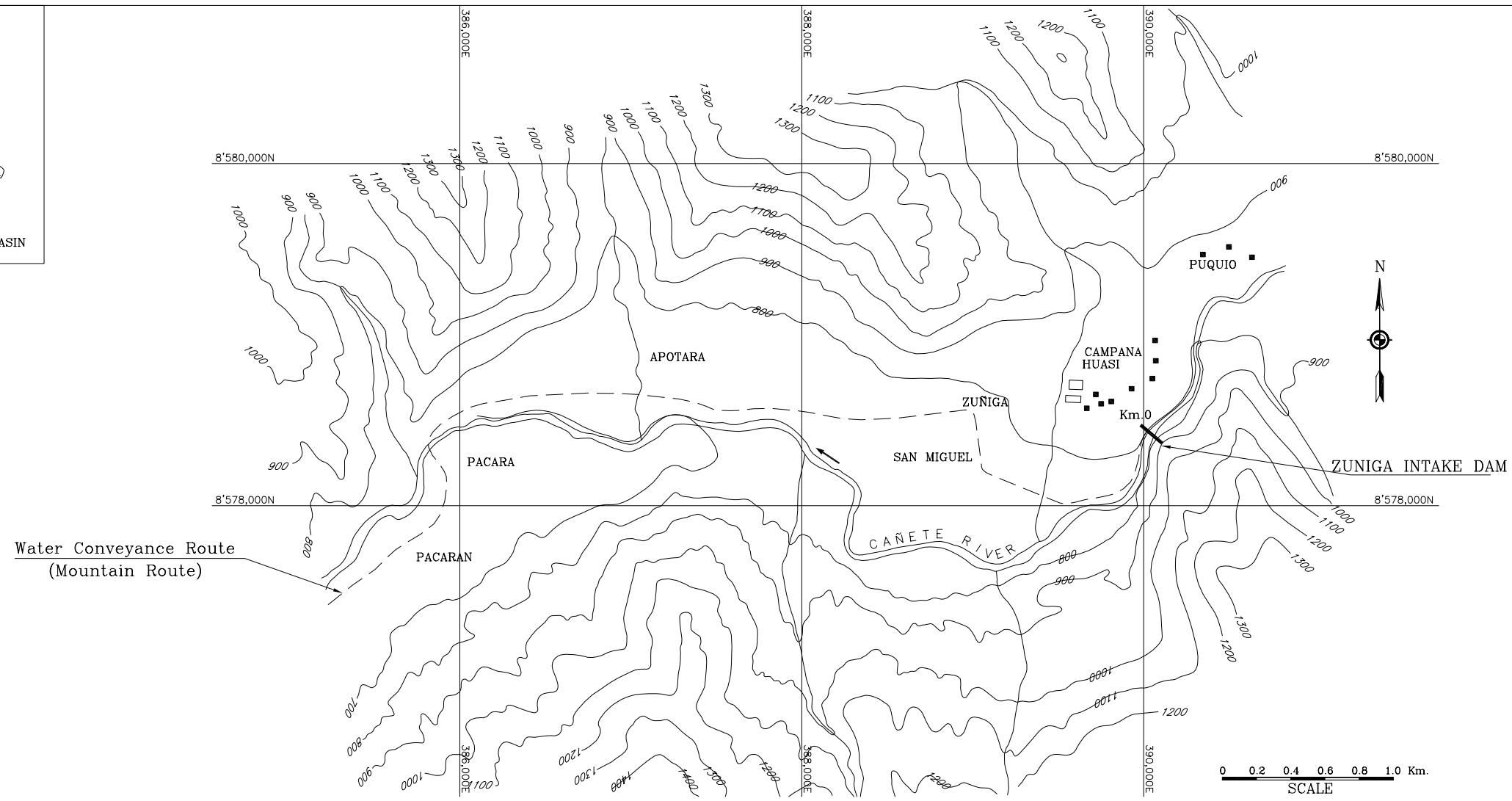
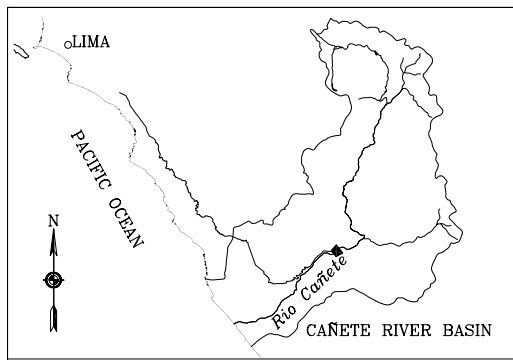

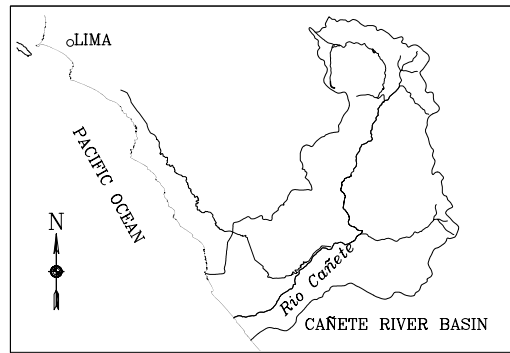

KEY MAP

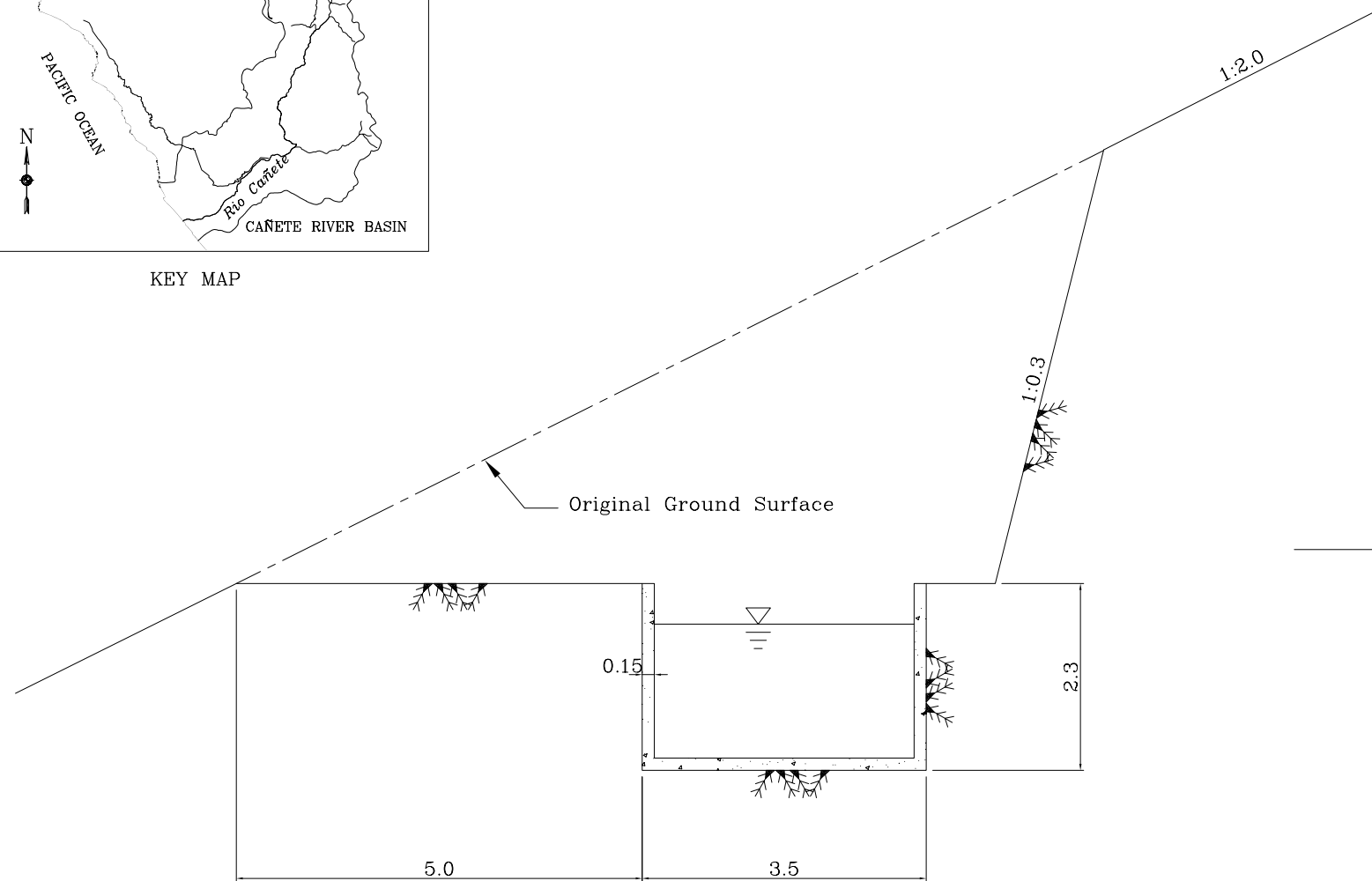

TYPICAL SECTION OF OPEN CHANNEL

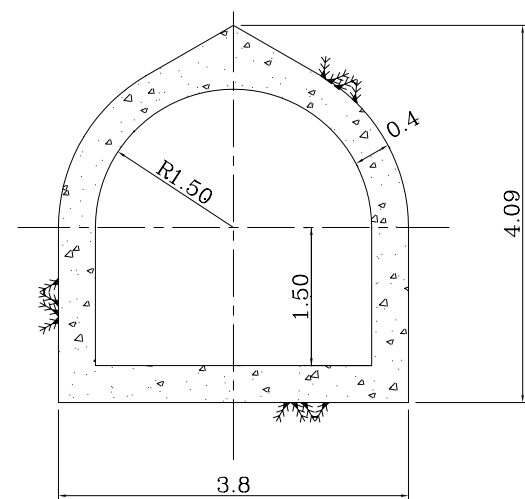

TYPICAL SECTION OF TUNNEL

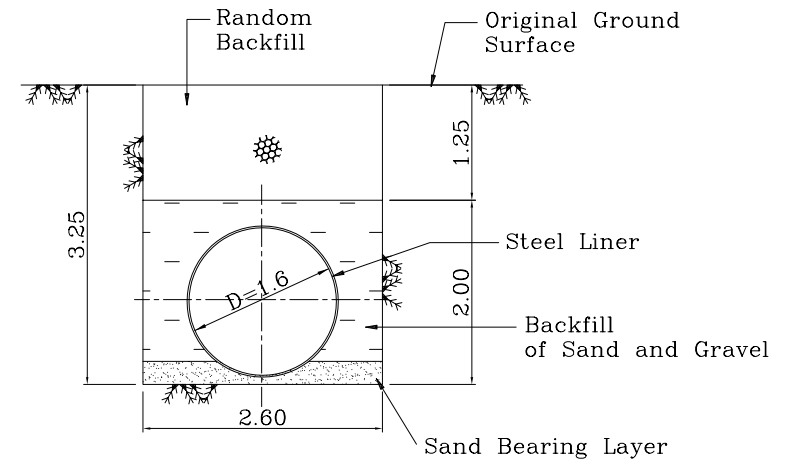
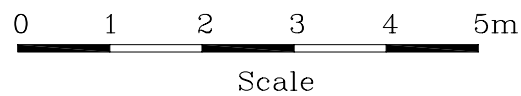

TYPICAL SECTION OF PIPE LINE

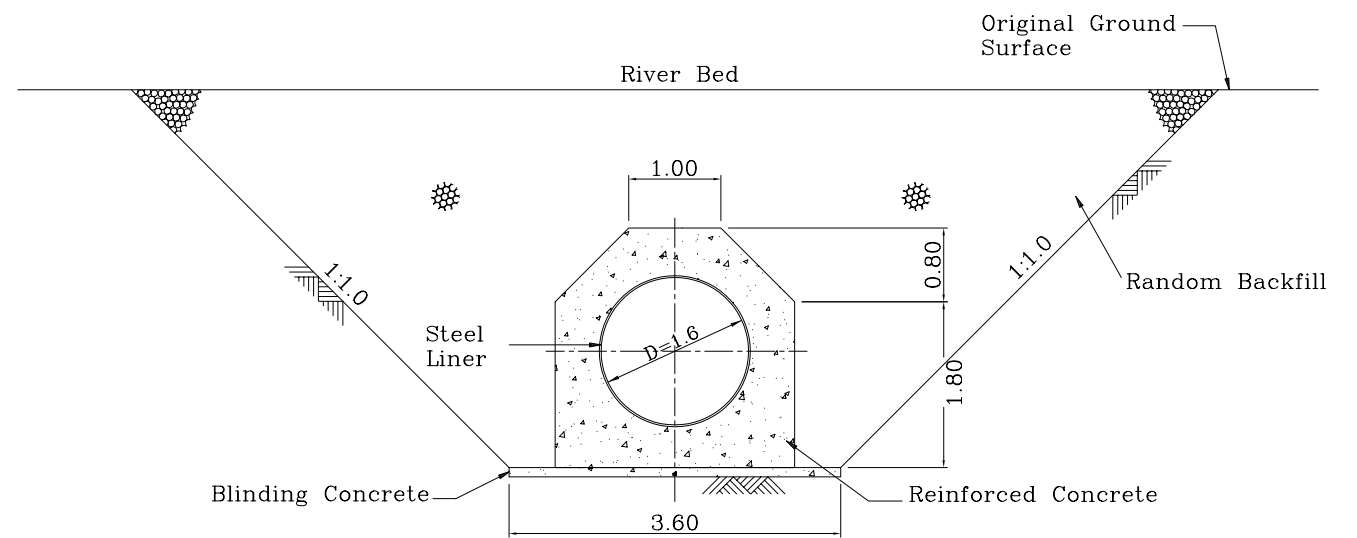

TYPICAL SECTION OF SIPHON (CROSSING RIVER BED)

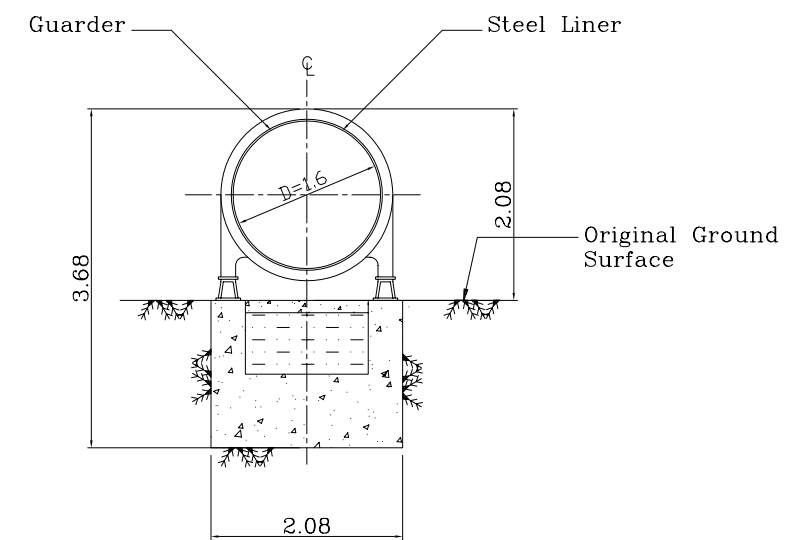

TYPICAL SECTION OF SIPHON (CROSSING ABATMENT)

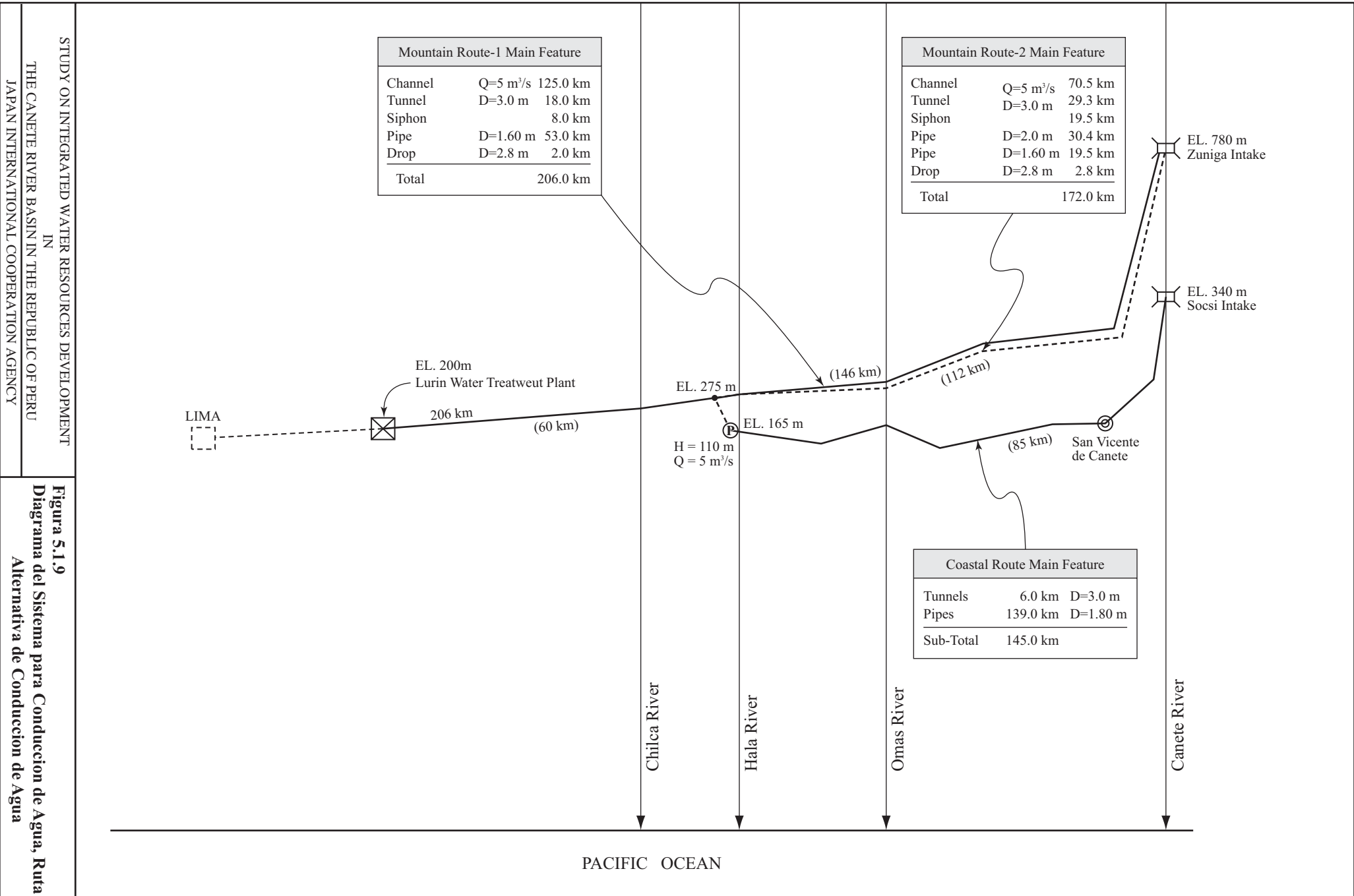

Figura 5.1.9
Diagrama del Sistema para Conduccion de Agua, Ruta Alternativa de Conduccion de Agua