

Note) Isohyet is cited from the "El Platanal Hydroelectric Power Plant Feasibility Study, 1987", ELECTROPERU

STUDY ON INTEGRATED WATER RESOURCES DEVELOPMENT
IN
THE CANETE RIVER BASIN IN THE REPUBLIC OF PERU
JAPAN INTERNATIONAL COOPERATION AGENCY

□ 1

Location of Meteorological and Hydrological Station

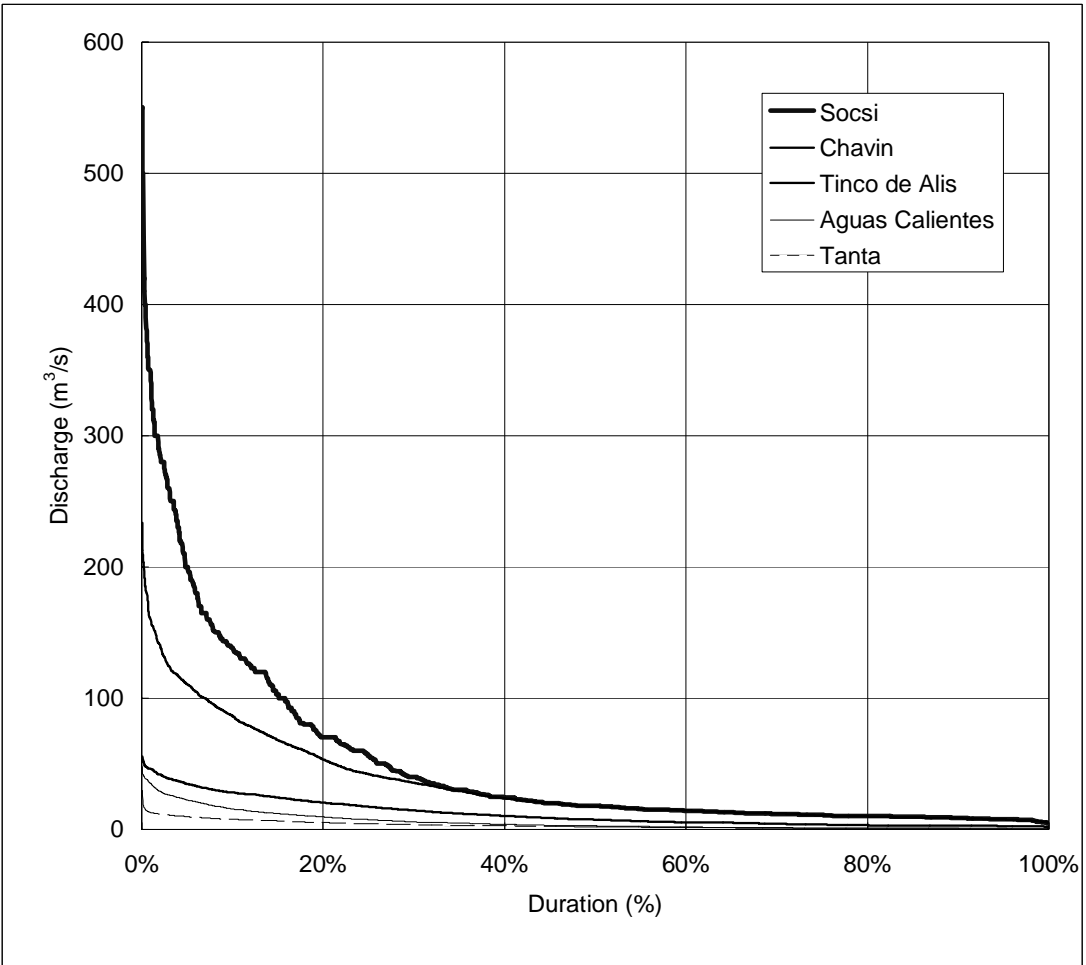

| Duration (%) | Discharge (m ³ /s) | | | | |
|--------------|-------------------------------|--------|---------------|-----------------|-------|
| | Socsi | Chavin | Tinco de Alis | Aguas Calientes | Tanta |
| 0.02% | 550.0 | 233.8 | 55.5 | 47.8 | 29.9 |
| 5% | 200.0 | 110.7 | 34.7 | 22.3 | 9.5 |
| 10% | 138.0 | 86.7 | 28.1 | 15.6 | 7.6 |
| 15% | 103.0 | 68.0 | 24.3 | 12.0 | 6.5 |
| 20% | 70.0 | 53.1 | 20.4 | 9.4 | 5.1 |
| 25% | 56.0 | 42.2 | 17.2 | 7.4 | 4.3 |
| 30% | 40.0 | 35.4 | 14.4 | 5.7 | 3.7 |
| 35% | 30.0 | 29.4 | 12.0 | 4.7 | 3.0 |
| 40% | 24.5 | 23.7 | 10.3 | 3.8 | 2.6 |
| 45% | 20.0 | 20.0 | 8.7 | 3.1 | 2.3 |
| 50% | 18.0 | 17.6 | 7.4 | 2.6 | 2.0 |
| 55% | 15.5 | 15.7 | 6.3 | 2.2 | 1.7 |
| 60% | 14.0 | 14.5 | 5.5 | 1.8 | 1.4 |
| 65% | 13.0 | 13.0 | 5.0 | 1.5 | 1.2 |
| 70% | 11.7 | 12.2 | 4.3 | 1.3 | 1.1 |
| 75% | 11.0 | 10.8 | 3.7 | 1.1 | 0.9 |
| 80% | 10.0 | 9.9 | 3.2 | 1.0 | 0.8 |
| 85% | 9.5 | 9.1 | 2.9 | 0.8 | 0.7 |
| 90% | 8.8 | 8.5 | 2.8 | 0.7 | 0.6 |
| 95% | 7.8 | 7.5 | 2.5 | 0.6 | 0.5 |
| 100% | 4.6 | 5.4 | 1.2 | 0.2 | 0.2 |

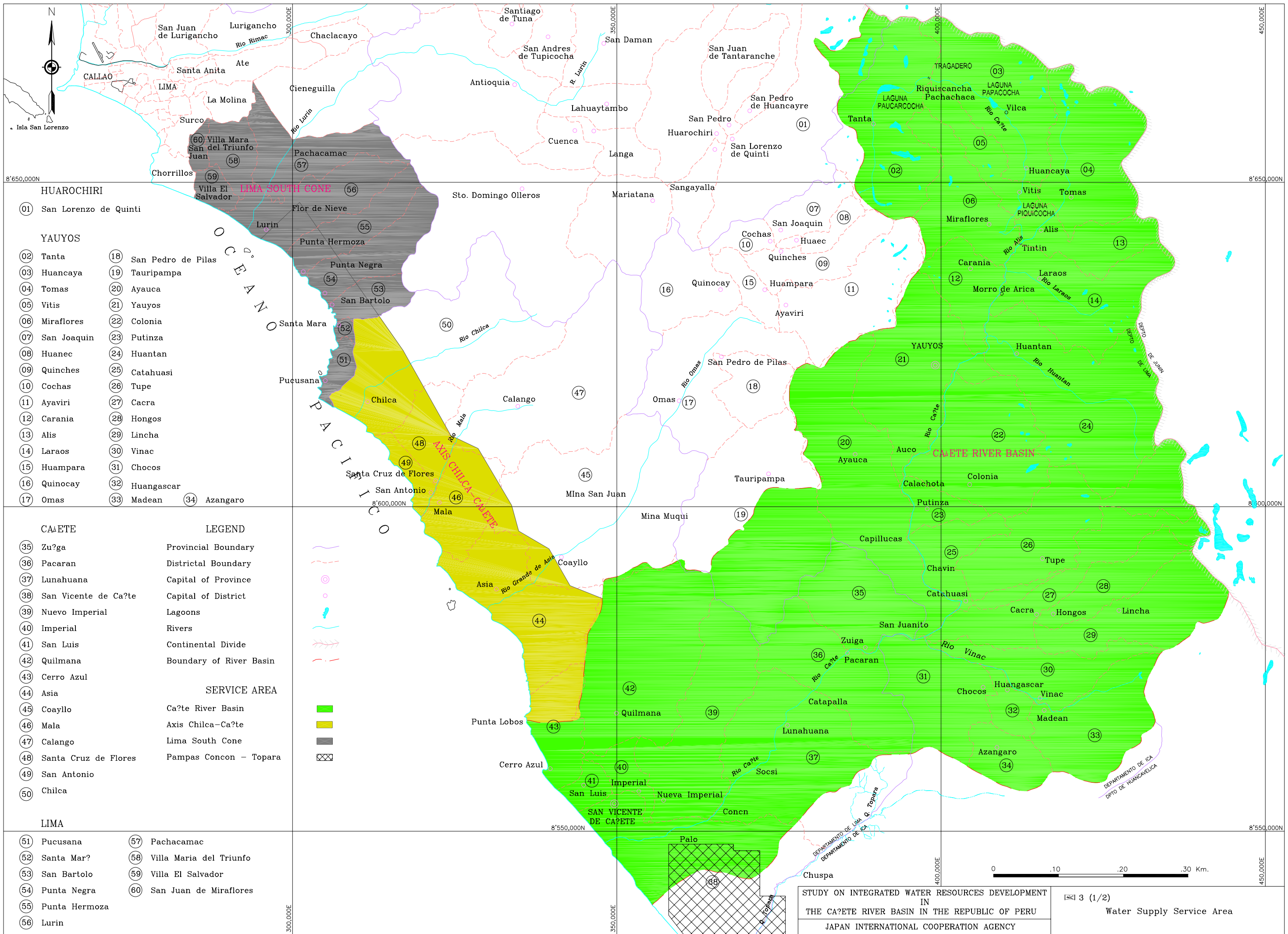

- | | |
|-------------------|-------------------------|
| HUAROCHIRI | |
| 01 | San Lorenzo de Quinti |
| YAUYOS | |
| 02 | Tanta |
| 03 | Huancaya |
| 04 | Tomas |
| 05 | Vitis |
| 06 | Miraflores |
| 07 | San Joaquin |
| 08 | Huanec |
| 09 | Quinchés |
| 10 | Cochas |
| 11 | Ayaviri |
| 12 | Carania |
| 13 | Alis |
| 14 | Laraos |
| 15 | Huampara |
| 16 | Quinocay |
| 17 | Omas |
| 18 | San Pedro de Pilas |
| 19 | Tauripampa |
| 20 | Ayauca |
| 21 | Yauyos |
| 22 | Colonia |
| 23 | Putinza |
| 24 | Huantan |
| 25 | Catahuasi |
| 26 | Tupe |
| 27 | Cacra |
| 28 | Hongos |
| 29 | Lincha |
| 30 | Vinac |
| 31 | Chocos |
| 32 | Huangascar |
| 33 | Madean |
| 34 | Azangaro |
| CAETE | |
| 35 | Zu?ga |
| 36 | Pacaran |
| 37 | Lunahuana |
| 38 | San Vicente de Ca?te |
| 39 | Nuevo Imperial |
| 40 | Imperial |
| 41 | San Luis |
| 42 | Quilmana |
| 43 | Cerro Azul |
| 44 | Asia |
| 45 | Coayllo |
| 46 | Mala |
| 47 | Calango |
| 48 | Santa Cruz de Flores |
| 49 | San Antonio |
| 50 | Chilca |
| LIMA | |
| 51 | Pucusana |
| 52 | Santa Mar? |
| 53 | San Bartolo |
| 54 | Punta Negra |
| 55 | Punta Hermoza |
| 56 | Lurin |
| 57 | Pachacamac |
| 58 | Villa Maria del Triunfo |
| 59 | Villa El Salvador |
| 60 | San Juan de Miraflores |

LEGEND

- Provincial Boundary
- - - Districtal Boundary
- Capital of Province
- Capital of District
- Lagoons
- Rivers
- Continental Divide
- - - Boundary of River Basin

SERVICE AREA

- Ca?te River Basin
- Axis Chilca-Ca?te
- Lima South Cone
- Pampas Concon - Topara

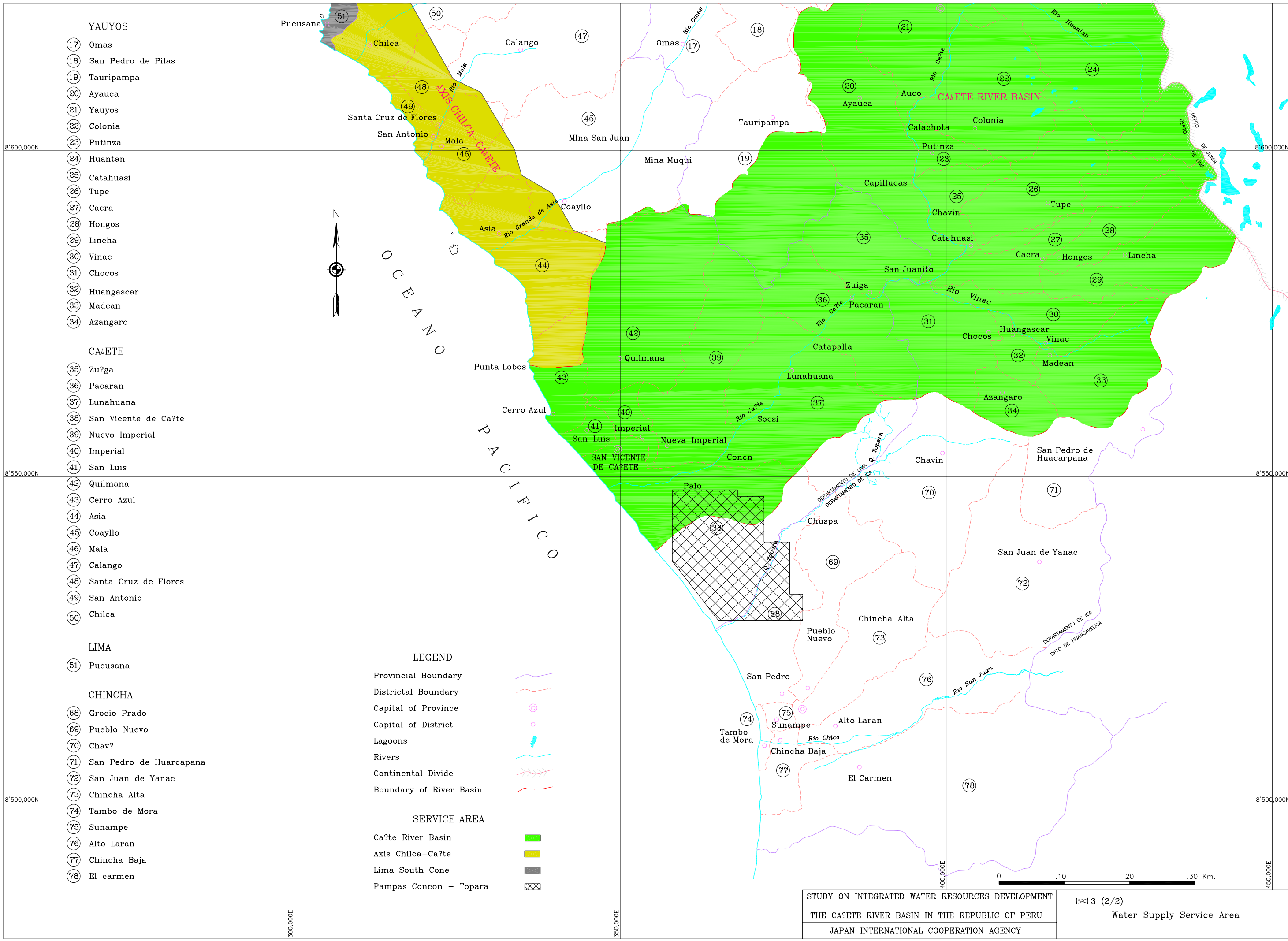

YAUYOS

- (17) Omas
- (18) San Pedro de Pilas
- (19) Tauripampa
- (20) Ayauca
- (21) Yauyos
- (22) Colonia
- (23) Putinza
- (24) Huantan
- (25) Catahuasi
- (26) Tupe
- (27) Cacara
- (28) Hongos
- (29) Lincha
- (30) Vinac
- (31) Chocos
- (32) Huangascar
- (33) Madean
- (34) Azangaro

CA?ETE

- (35) Zu?ga
- (36) Pacaran
- (37) Lunahuana
- (38) San Vicente de Ca?te
- (39) Nuevo Imperial
- (40) Imperial
- (41) San Luis

- (42) Quilmana
- (43) Cerro Azul
- (44) Asia
- (45) Coayllo
- (46) Mala
- (47) Calango
- (48) Santa Cruz de Flores
- (49) San Antonio
- (50) Chilca

LIMA

- (51) Pucusana

CHINCHA

- (68) Grocio Prado
- (69) Pueblo Nuevo
- (70) Chav?
- (71) San Pedro de Huarcapana
- (72) San Juan de Yanac
- (73) Chincha Alta
- (74) Tambo de Mora
- (75) Sunampe
- (76) Alto Laran
- (77) Chincha Baja
- (78) El carmen

LEGEND

- Provincial Boundary
- Districtal Boundary
- Capital of Province
- Capital of District
- Lagoons
- Rivers
- Continental Divide
- Boundary of River Basin

SERVICE AREA

- Ca?ete River Basin
- Axis Chilca-Ca?ete
- Lima South Cone
- Pampas Concon - Topara

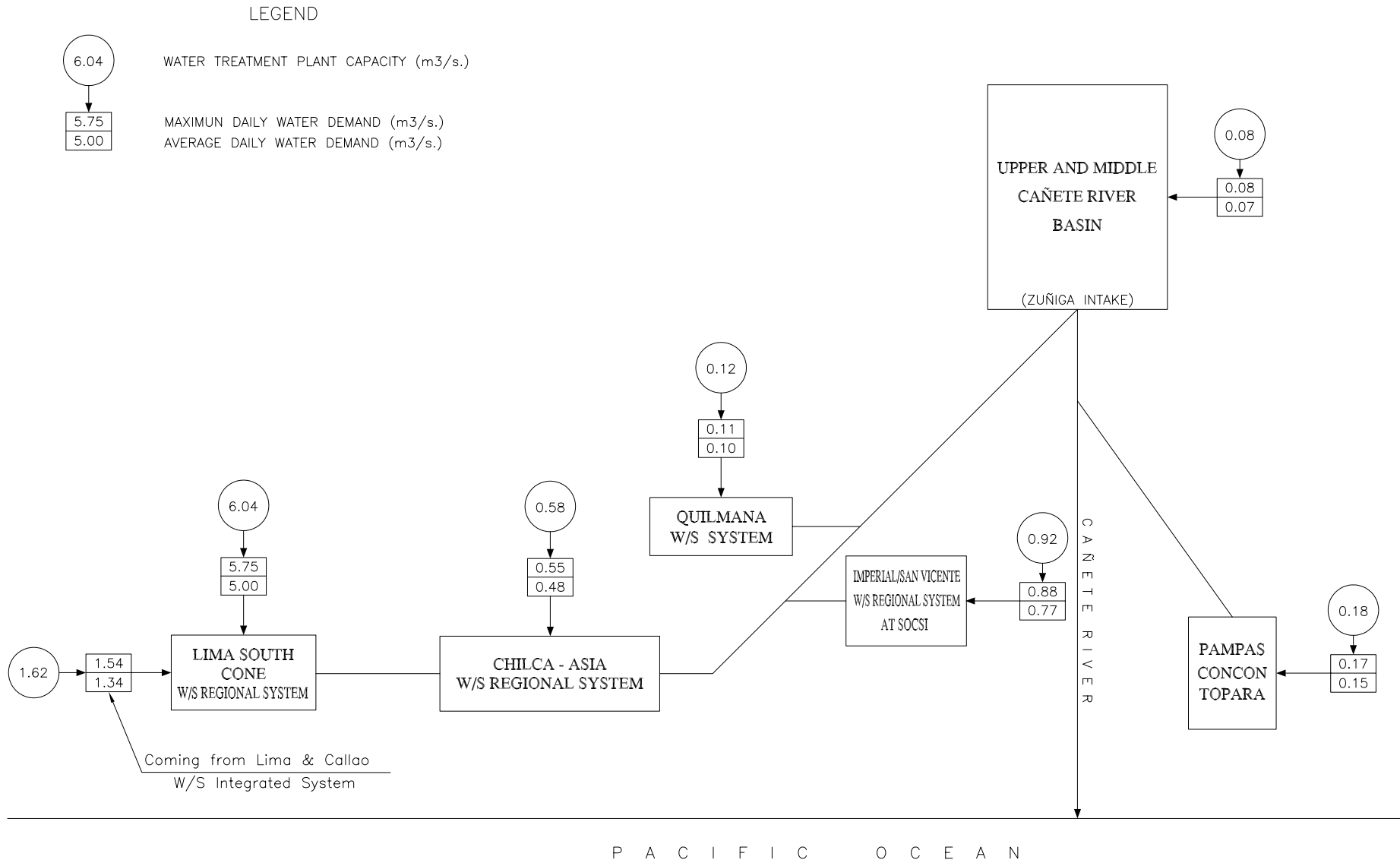

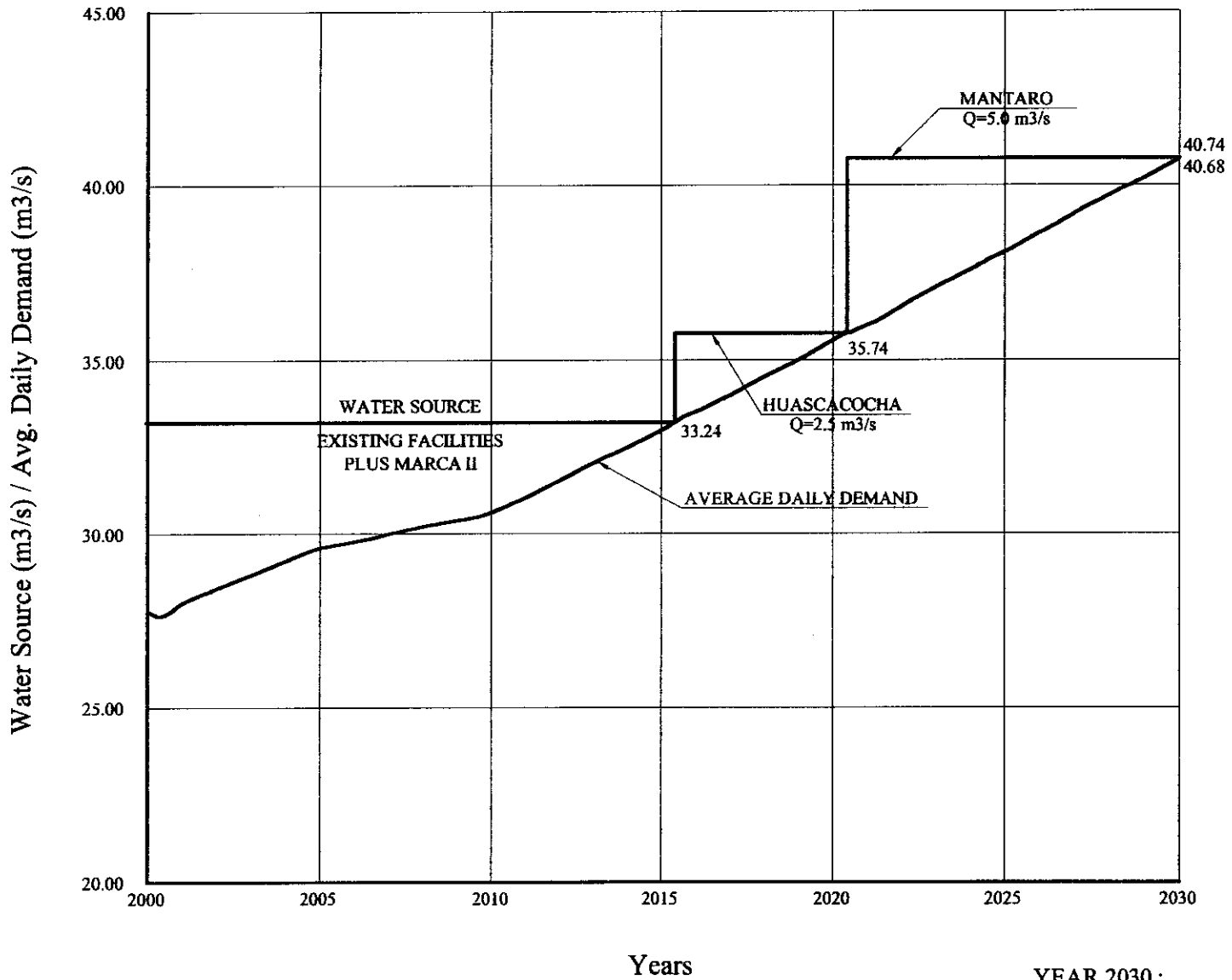

YEAR 2030 :
 WATER SOURCE : 40.74m³/s
 AVERAGE DAILY DEMAND : 40.68m³/s

STUDY ON INTEGRATED WATER RESOURCES DEVELOPMENT
 IN
 THE CANETE RIVER BASIN IN THE REPUBLIC OF PERU
 JAPAN INTERNATIONAL COOPERATION AGENCY





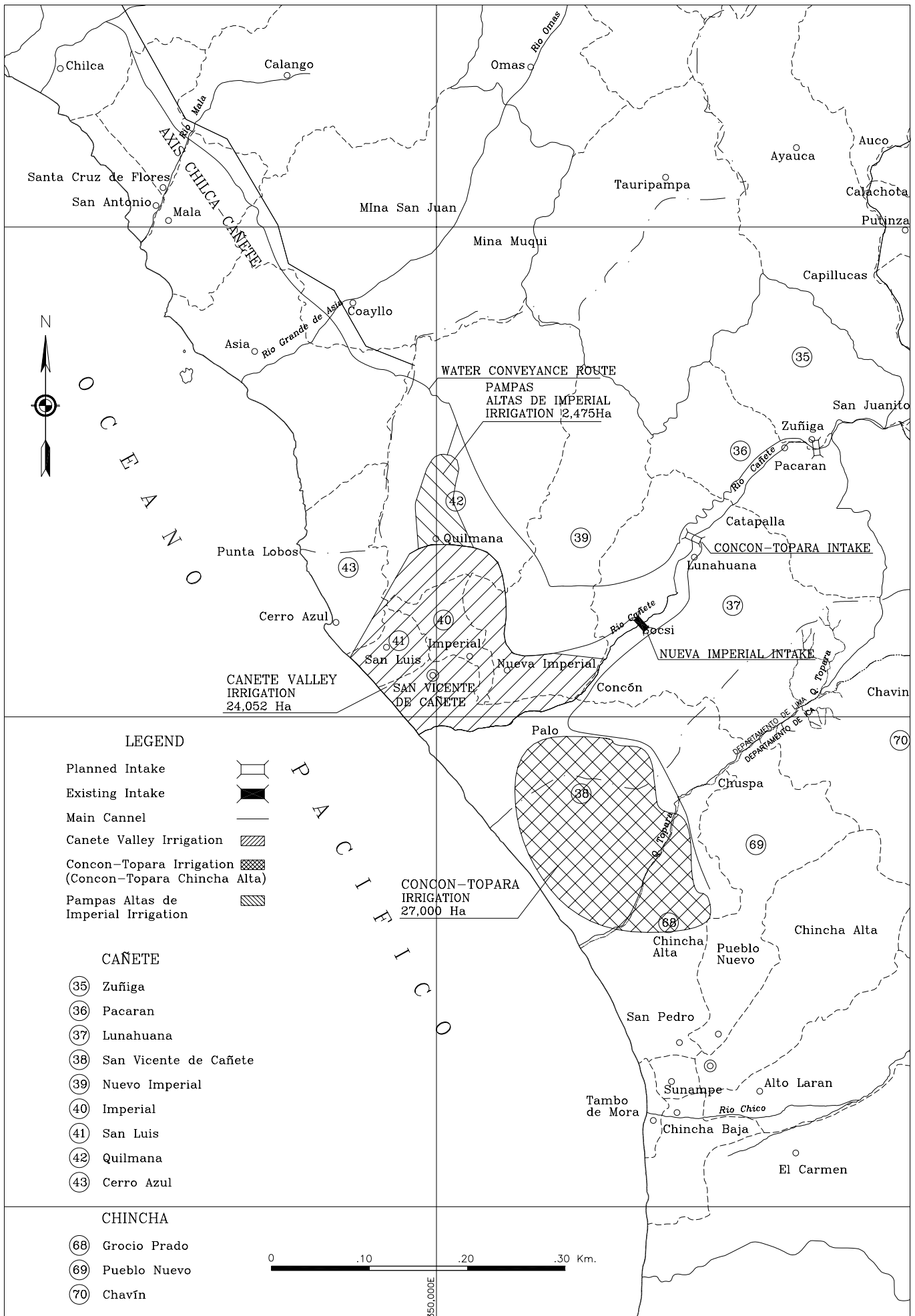



6 Existing Cropping Pattern in the
 Valle de Cañete (24,052 ha)

| CROP ha | LAND AREA ha | CROP AREA ha | JAN. | FEB. | MAR. | APR. | MAY | JUN. | JUL. | AUG. | SET. | OCT. | NOV. | DEC. | | |
|---|--------------------|--------------------|-------------------------|---------------|------|--------|------------|--------|------|------|---------------|-----------------------|------|------|--|--|
| 1 Cotton | 10,726 | 10,726 | Cotton | | | | | Cotton | | | | | | | | |
| 2 Starchy maize / Potato | 2,745 | 4,118 | Starchy maize | | | Potato | | | | | Starchy maize | | | | | |
| 3 Yellow maize for feed / Starchy maize | 1,965 | 3,930 | Yellow maize | Starchy maize | | | | | | | | Yellow maize for feed | | | | |
| 4 Yellow maize for feed | 1,965 | 1,965 | Chala Corn | | | | Chala Corn | | | | | | | | | |
| 5 Cotton in the submerged area | 1,811 | 1,811 | Cotton | | | | | Cotton | | | | | | | | |
| 6 Horticulture | 868 | 868 | Horticulture | | | | | | | | | | | | | |
| 7 Citrus | 819 | 819 | Citrus | | | | | | | | | | | | | |
| 8 Fruit trees (apple, grape, etc.) | 1,710 | 1,710 | Fruit trees | | | | | | | | | | | | | |
| 9 Pasture (alfalfa, etc.) | 667 | 667 | Pasture (alfalfa, etc.) | | | | | | | | | | | | | |
| 10 Starchy maize | 776 | 776 | Starchy maize | | | | | | | | | | | | | |
| Total | 24,052 | 27,390 | | | | | | | | | | | | | | |





LEGEND

-  220 kV MAIN CENTER-NORTH NATIONAL INTERCONNECTED SYSTEM (SICN)
-  138 kV MAIN SOUTH INTERCONNECTED SYSTEM (SISUR)
-  220 kV CENTER-NORTH & SOUTH INTERCONNECTED SYSTEMS (SICN-SISUR)
-  220 kV TRANSMISSION LINE
-  138 kV TRANSMISSION LINE
-  69-60 kV TRANSMISSION LINE
-  HYDROPOWER
-  THERMAL STATION

NATIONAL INTERCONNECTED SYSTEM

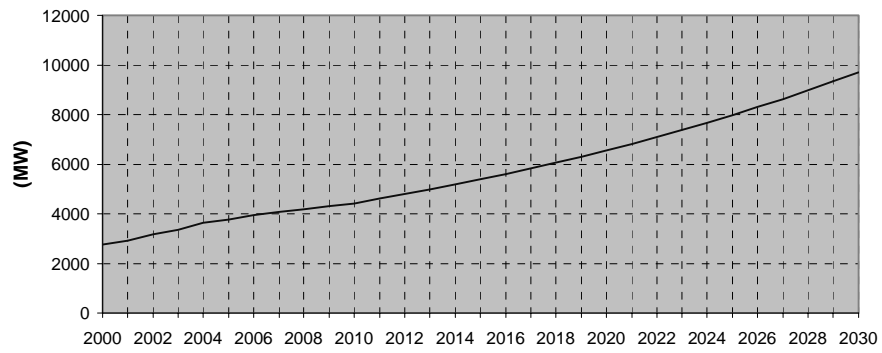

STUDY AREA

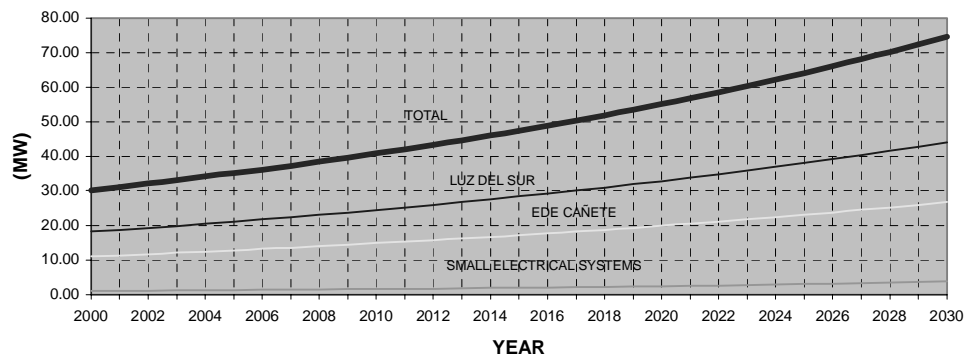

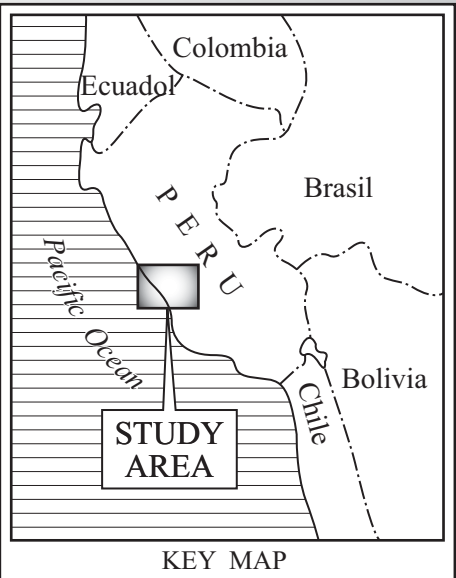
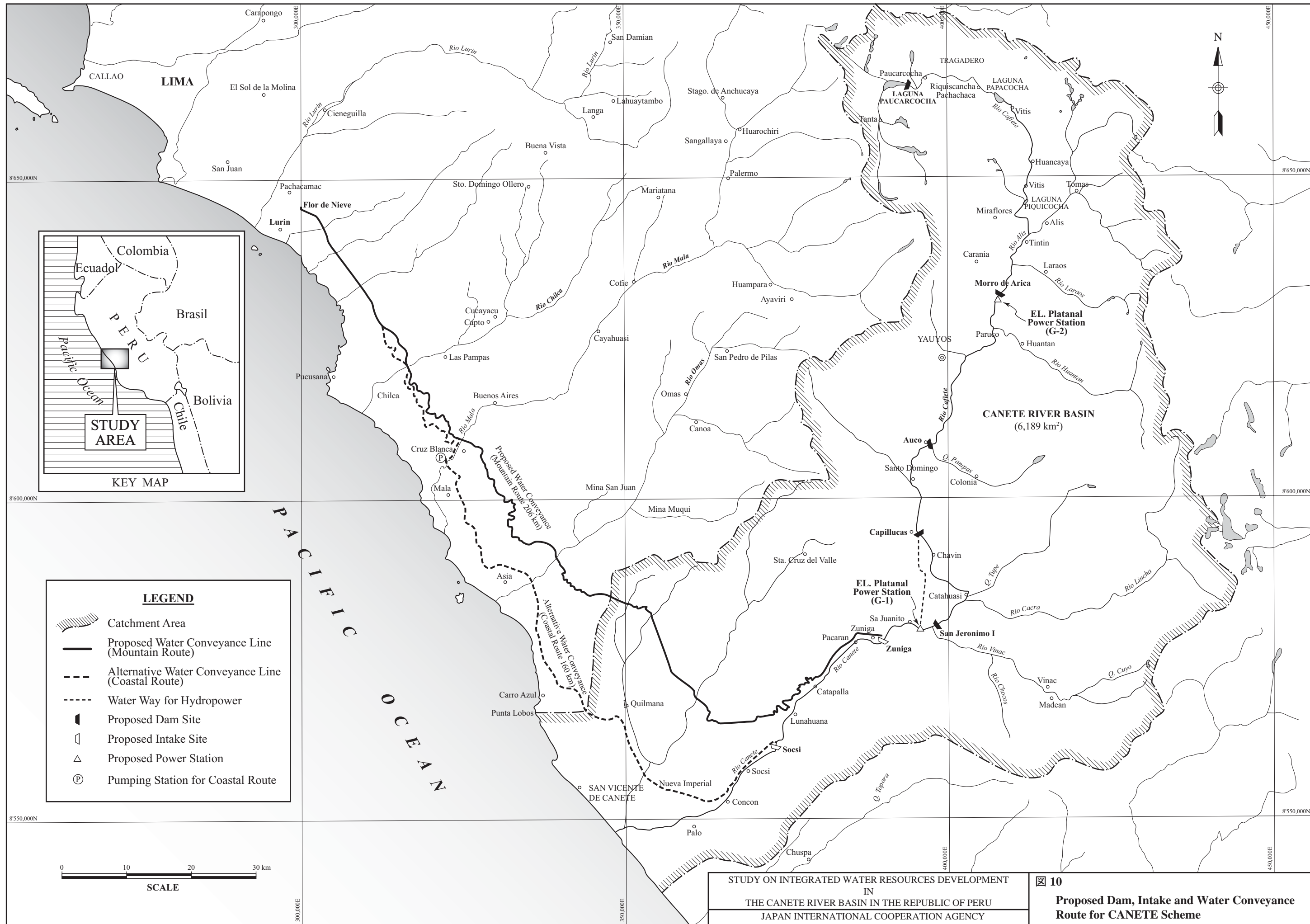

LEGEND

- Catchment Area
- Proposed Water Conveyance Line (Mountain Route)
- Alternative Water Conveyance Line (Coastal Route)
- Water Way for Hydropower
- Proposed Dam Site
- Proposed Intake Site
- Proposed Power Station
- Pumping Station for Coastal Route



STUDY ON INTEGRATED WATER RESOURCES DEVELOPMENT
 IN
 THE CANETE RIVER BASIN IN THE REPUBLIC OF PERU
 JAPAN INTERNATIONAL COOPERATION AGENCY

10
Proposed Dam, Intake and Water Conveyance Route for CANETE Scheme

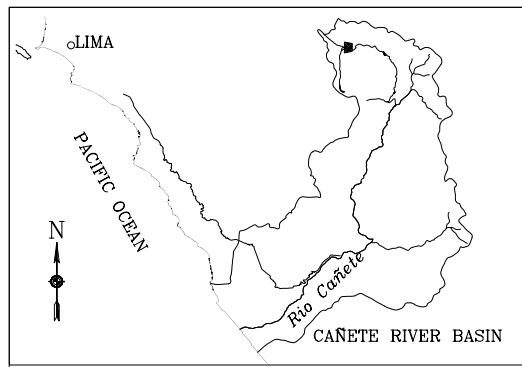

KEY MAP

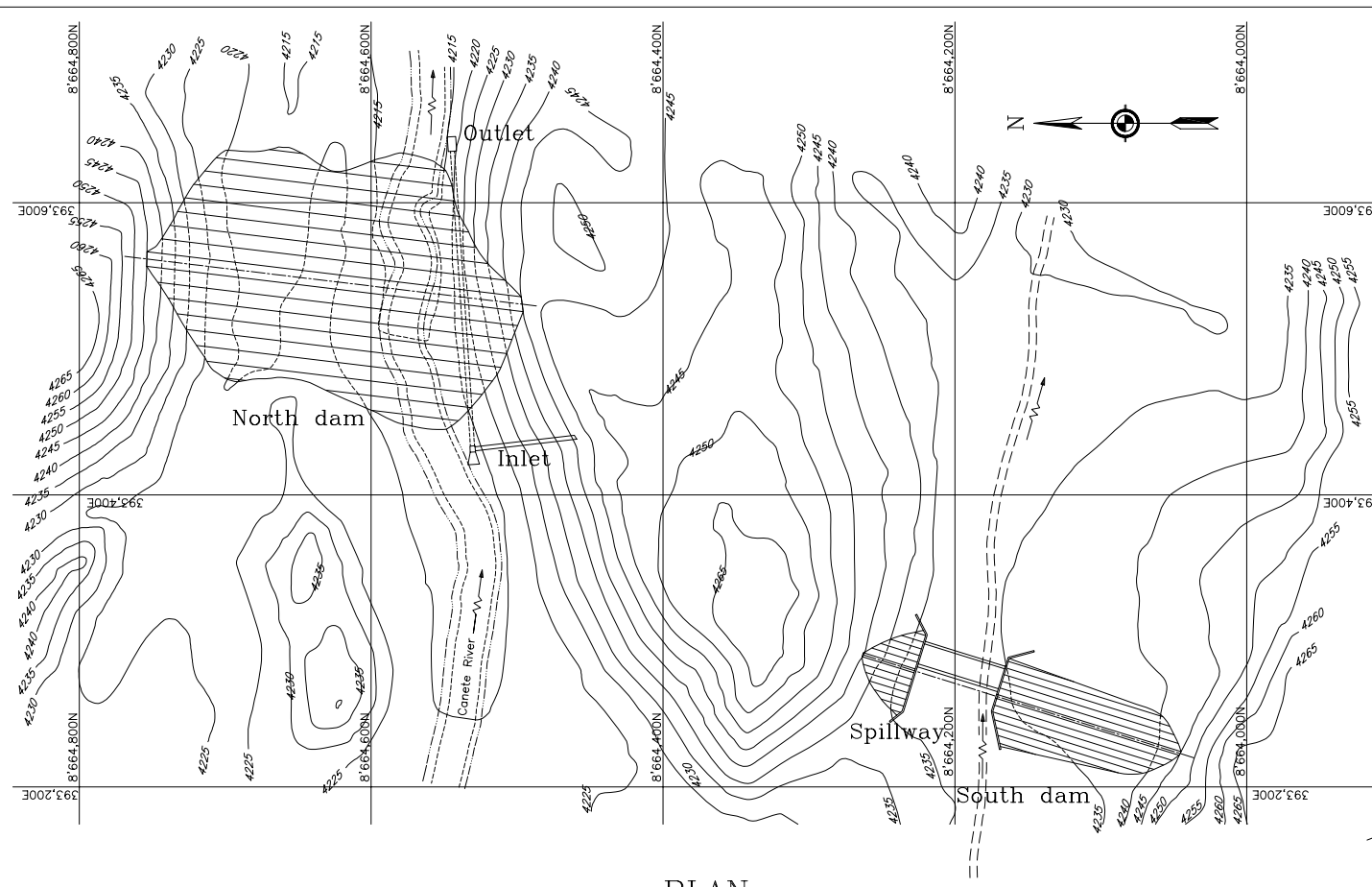

PLAN

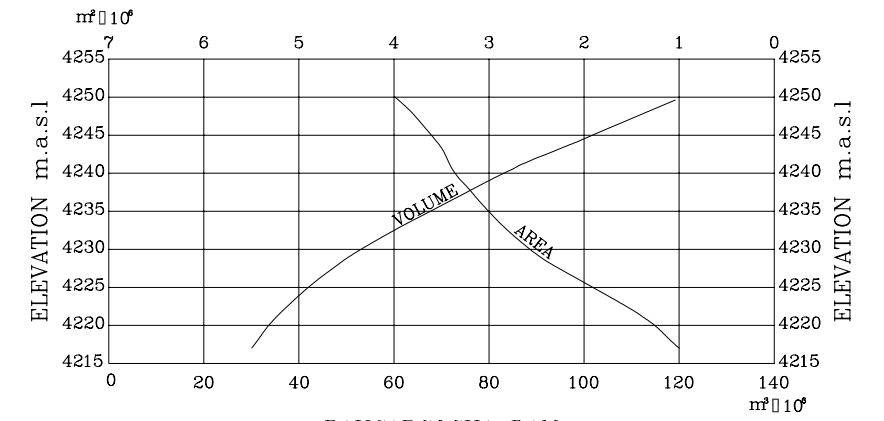
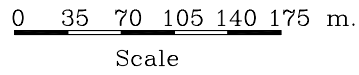

PAUCARCOCHA DAM
AREA - CAPACITY CURVE

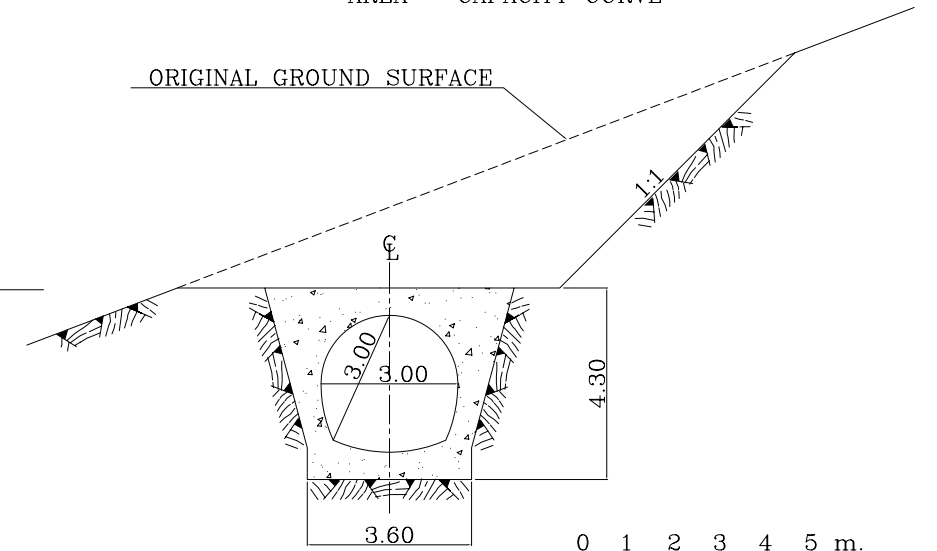

SECTION OF DIVERSION CONDUIT

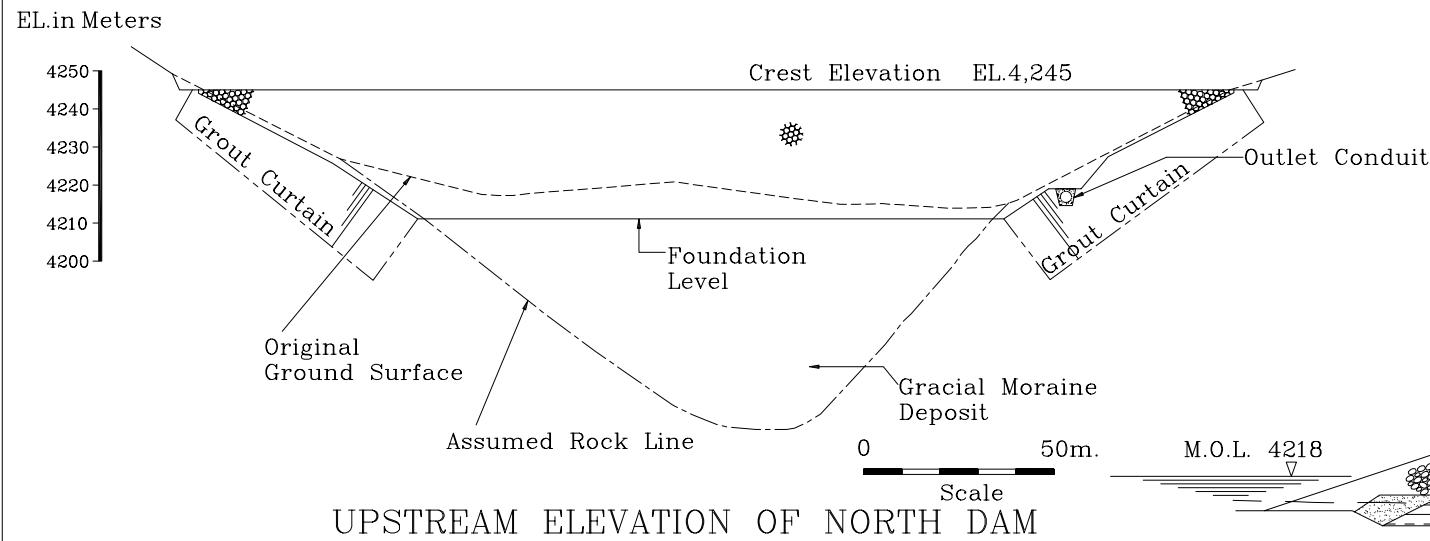
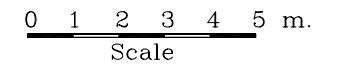

UPSTREAM ELEVATION OF NORTH DAM



- LEGEND
- ① IMPERVIOUS CORE
 - ② FINE FILTER
 - ③ COURSE FILTER
 - ④ PERVIOUS GRANULAR FILL
 - ⑤ RIPRAP

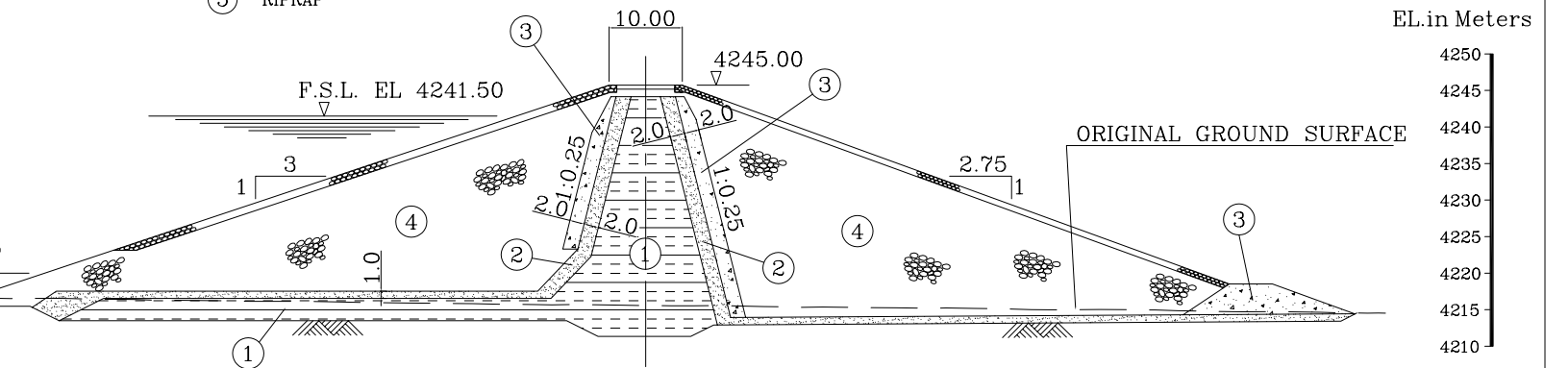

TYPICAL SECTION OF NORTH DAM

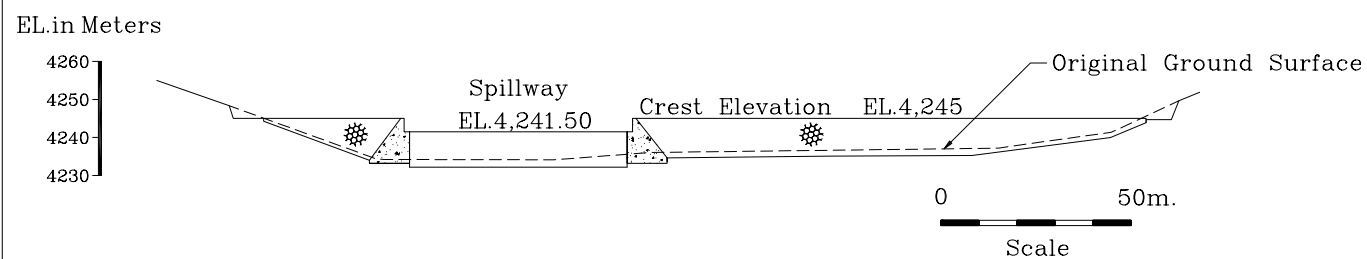
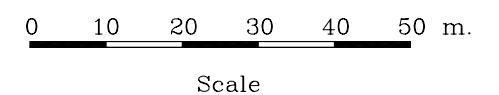

UPSTREAM ELEVATION OF SOUTH DAM



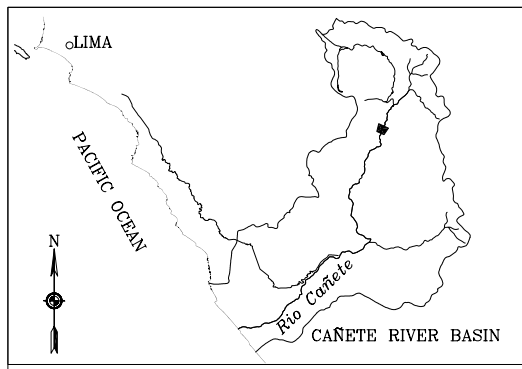

KEY MAP

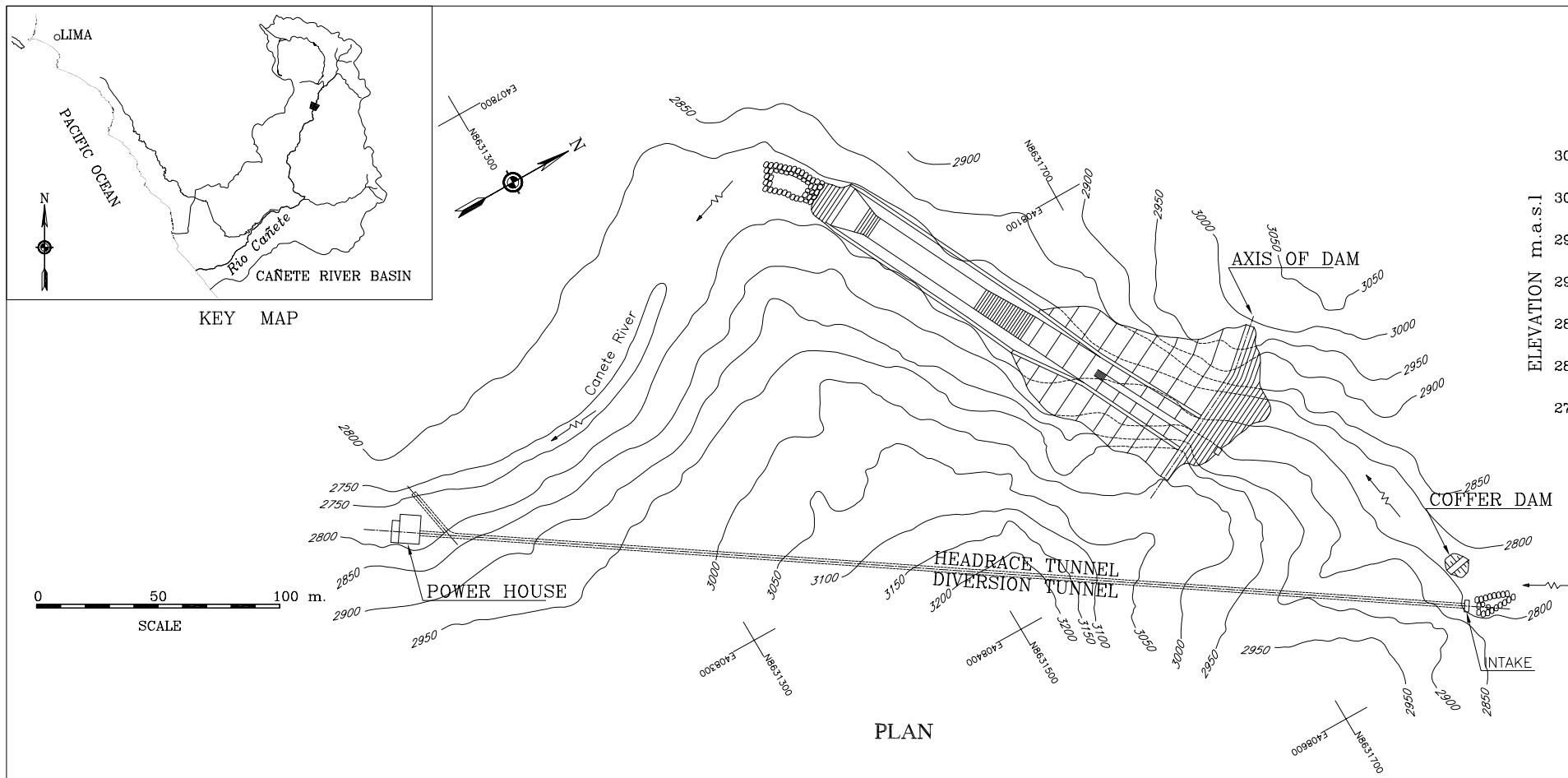

PLAN

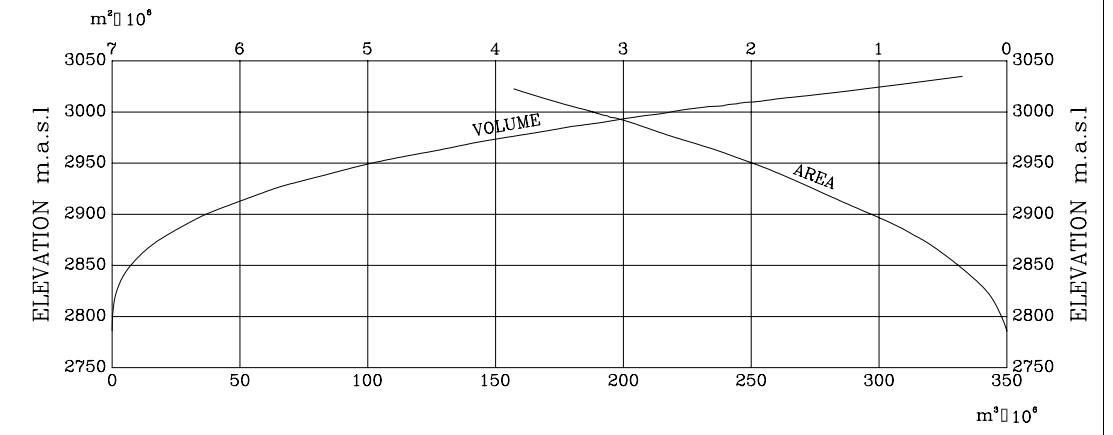

MORRO DE ARICA DAM
AREA-CAPACITY CURVE

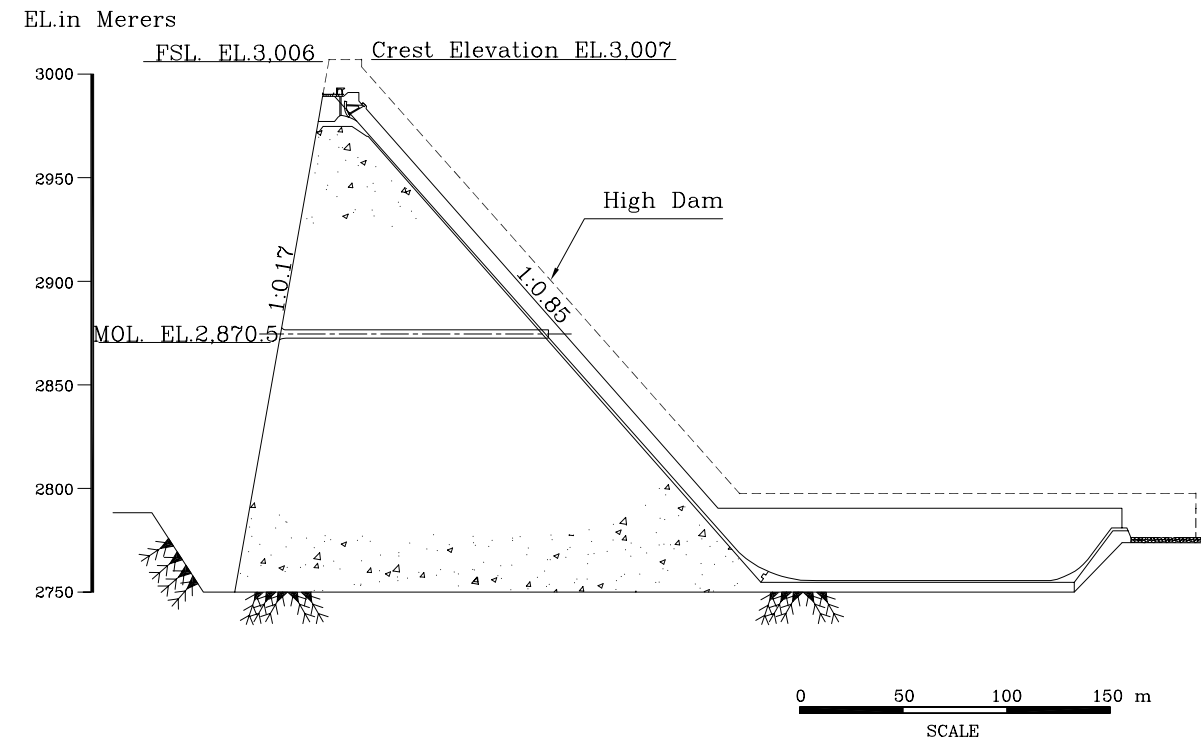

TYPICAL CROSS SECTION OF DAM

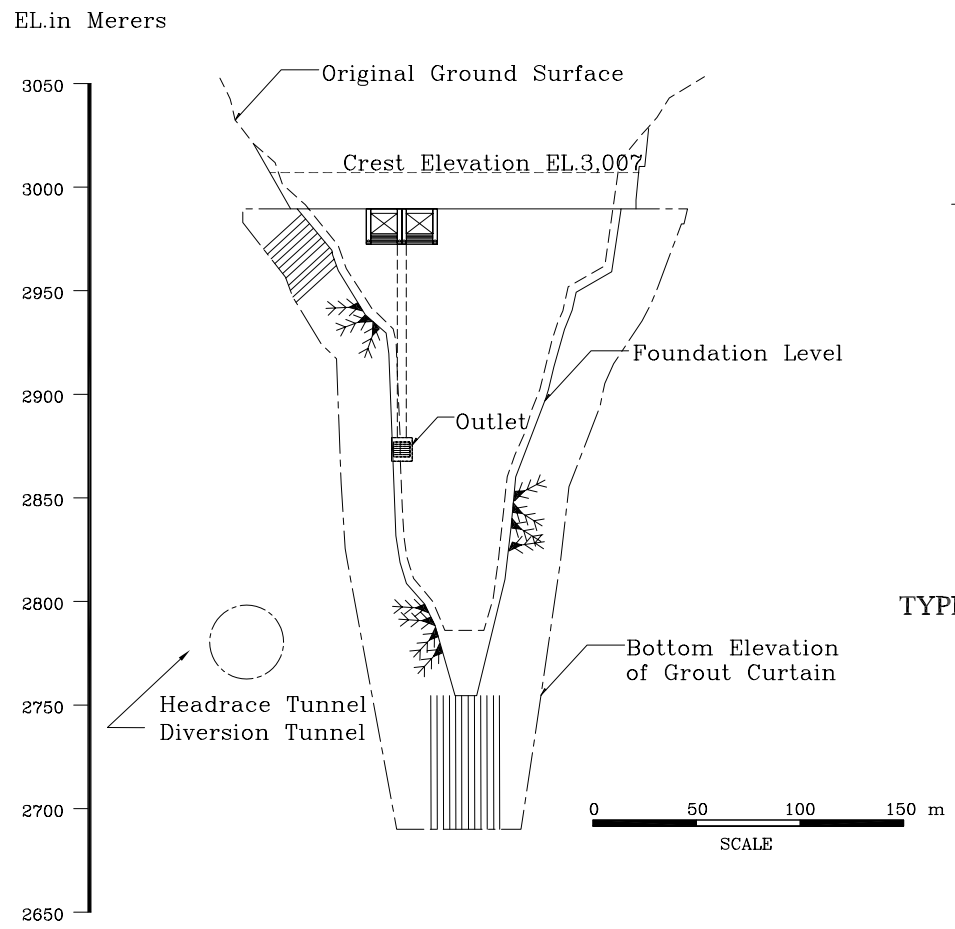

UPSTREAM ELEVATION

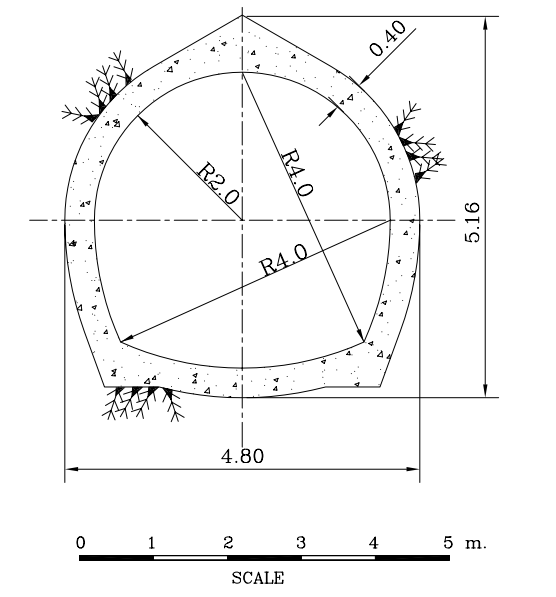

TYPICAL SECTION OF HEADRACE TUNNEL

- Notes:
- 1) Original design prepared by ARPL TECHNOLOGIA INDUSTRIAL S.A.
 - 2) Crest Elevation(EL.3,007), FSL(EL.3,006), MOL(EL.2,870.5) for high dam are proposed by the JICA Study Team.

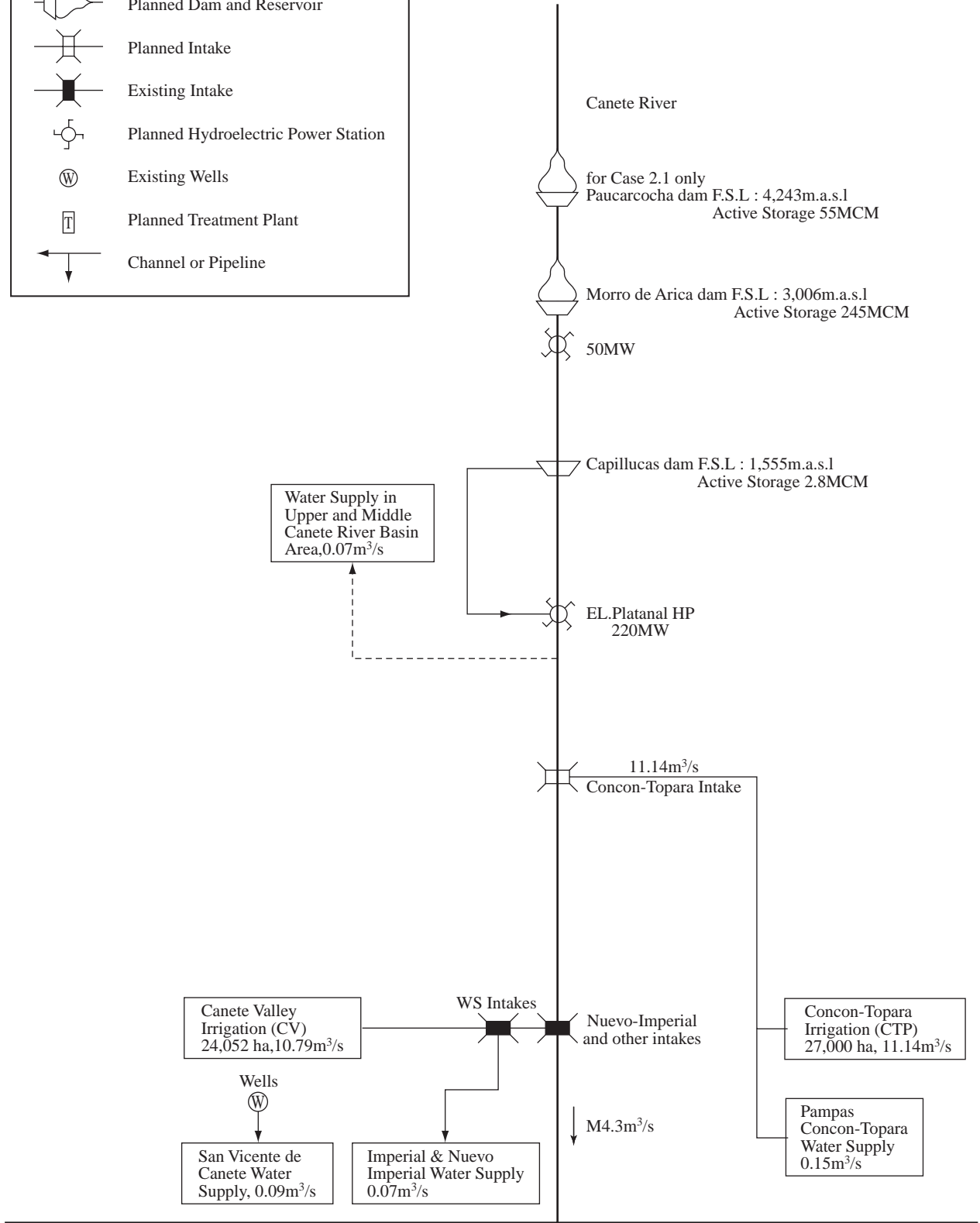
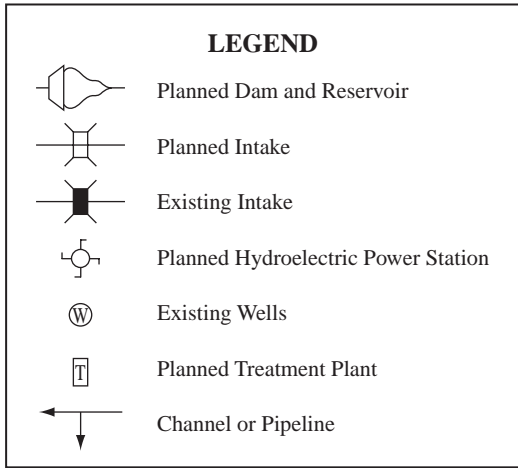

Note : Selected Case 2.1

PACIFIC OCEAN

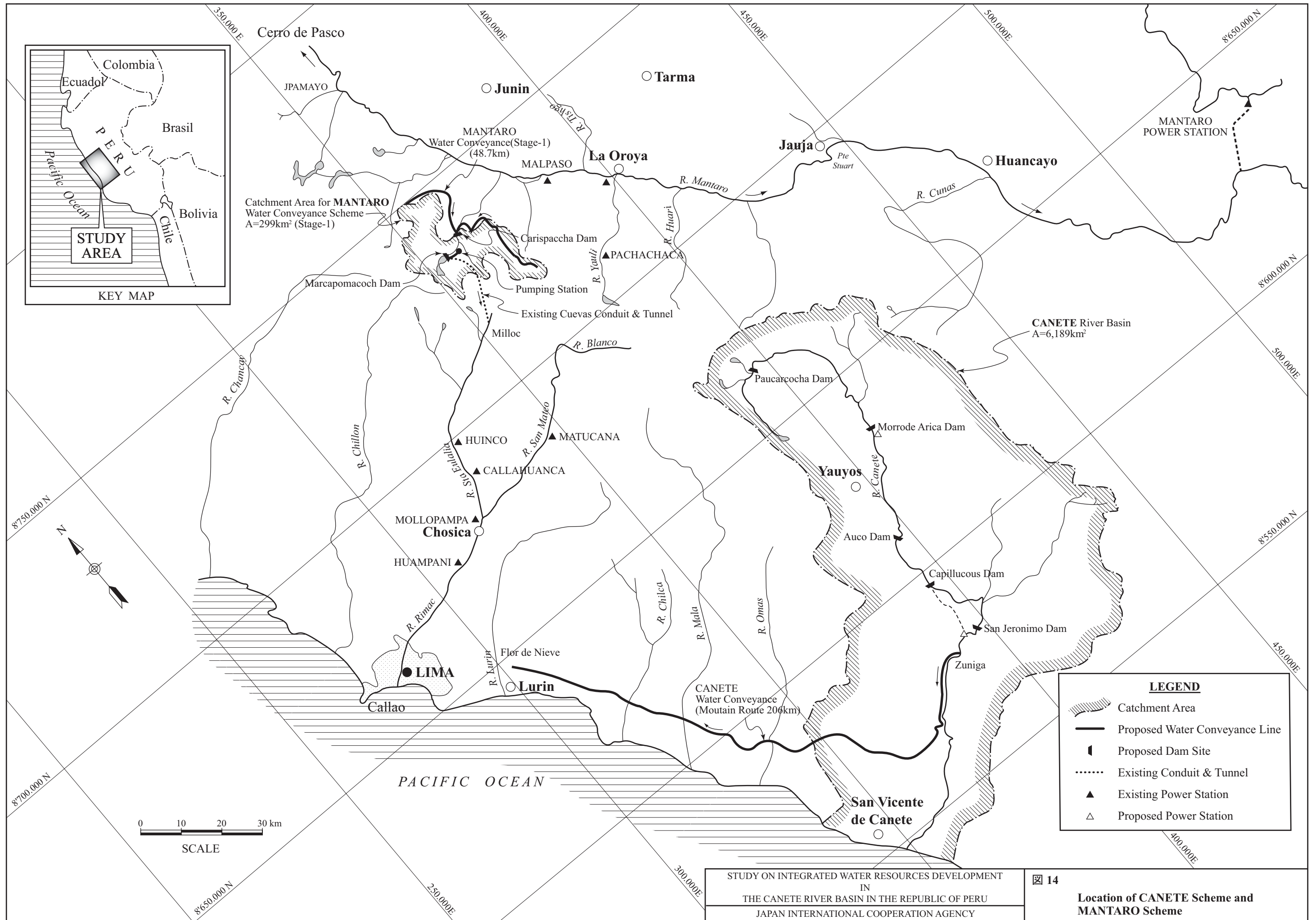

LEGEND

- Catchment Area
- Proposed Water Conveyance Line
- Proposed Dam Site
- Existing Conduit & Tunnel
- Existing Power Station
- Proposed Power Station



Implementation Schedule of Water Resources Development Projects

| Project | Dimension | Status | Calendar year | | | | | | | | | | | | | Remarks | |
|---------------------------------|------------------------|-----------|---------------|------|------|------|------|------|------|------|------|------|------|------|------|---------------------------------|------------------------------------|
| | | | 2000 | 2001 | 2002 | 2003 | 2004 | 2005 | 2006 | 2007 | 2008 | 2009 | 2010 | 2011 | 2012 | | |
| D/I Water Supply | | | | | | | | | | | | | | | | | |
| (1) To Lima | 5 m ³ /s | New | | | | | | | | | | | | | | F/S suspended | |
| (2) To Cañete basin | 0.87 m ³ /s | New | ----- | | | | | | | | | | | | | Start of operation in 2021/2026 | |
| (3) To Concón-Topará | 0.15 m ³ /s | New | | | | ■ | | | | | ▼ | | | | | Schedule by Cementos Lima | |
| Agriculture (Irrigation) | | | | | | | | | | | | | | | | | |
| (1) Cañete Valley | 24,000 ha | Rehabili. | ■ | | | | ▼ | | | | | | | | | On-going | |
| (2) Concón-Topará | 27,000 ha | New | | | | ■ | | | | | | | | | ▼ | | Assumed 10 year plan starting 2003 |
| Hydropower | | | | | | | | | | | | | | | | | |
| (1) Morro de Arica | 50 MW | New | | | | ■ | | | ▼ | | | | | | | Schedule by Cementos Lima | |
| (2) El Platanal | 220 MW | New | | | | ■ | | | ▼ | | | | | | | ditto | |

Legend: Stepwise Implementation
 Implementation (Design and Construction)
 Start of Operation

SEDAPAL SPECIFIC ORGANIZATIONAL CHART

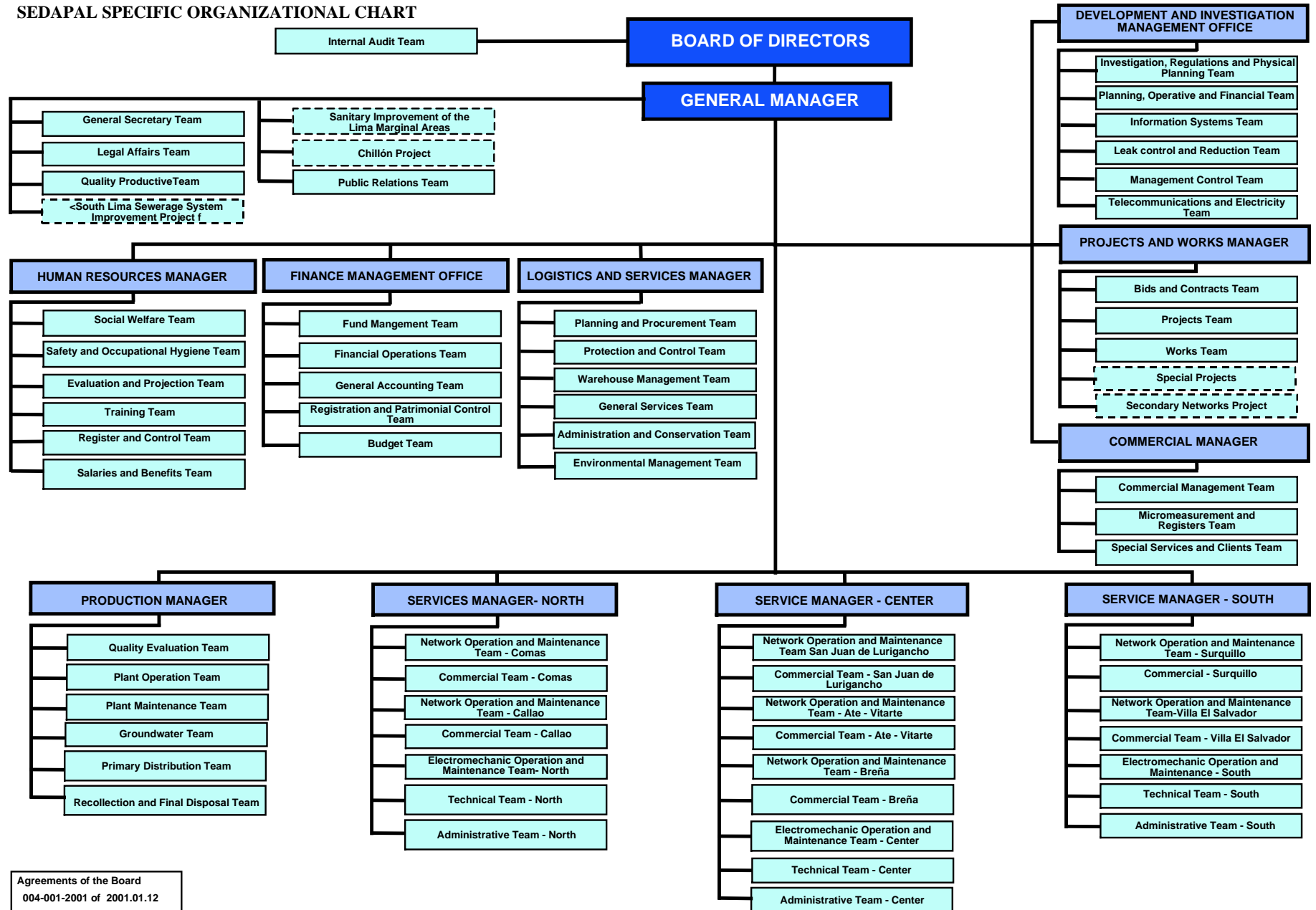

Agreements of the Board
004-001-2001 of 2001.01.12

River administration in 1999

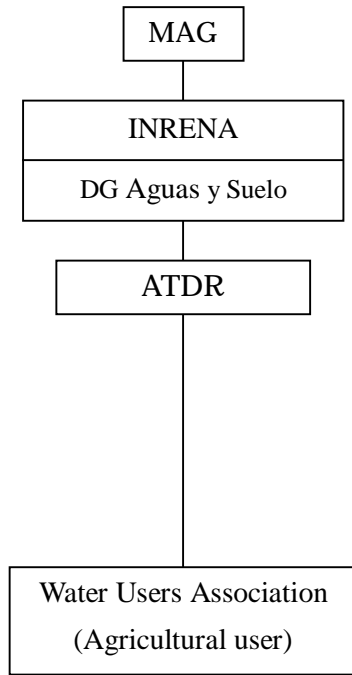

(Proposed in 1999)

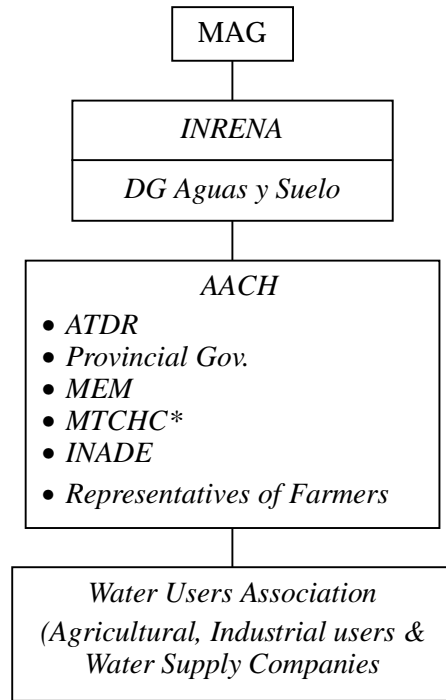

River administration after July 2001

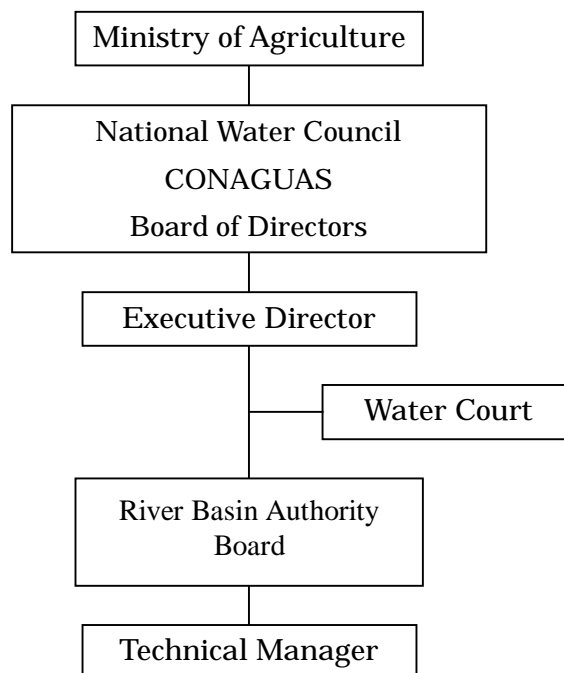

*MTCHC = Ministry of Transportation,
Communication, Housing and Construction