

FEASIBILITY STUDY ON  
WATER RESOURCES DEVELOPMENT  
IN RURAL AREA

JAPAN INTERNATIONAL COOPERATION AGENCY

Figure S5

流域管理境界及び調査地域のゾーン分け

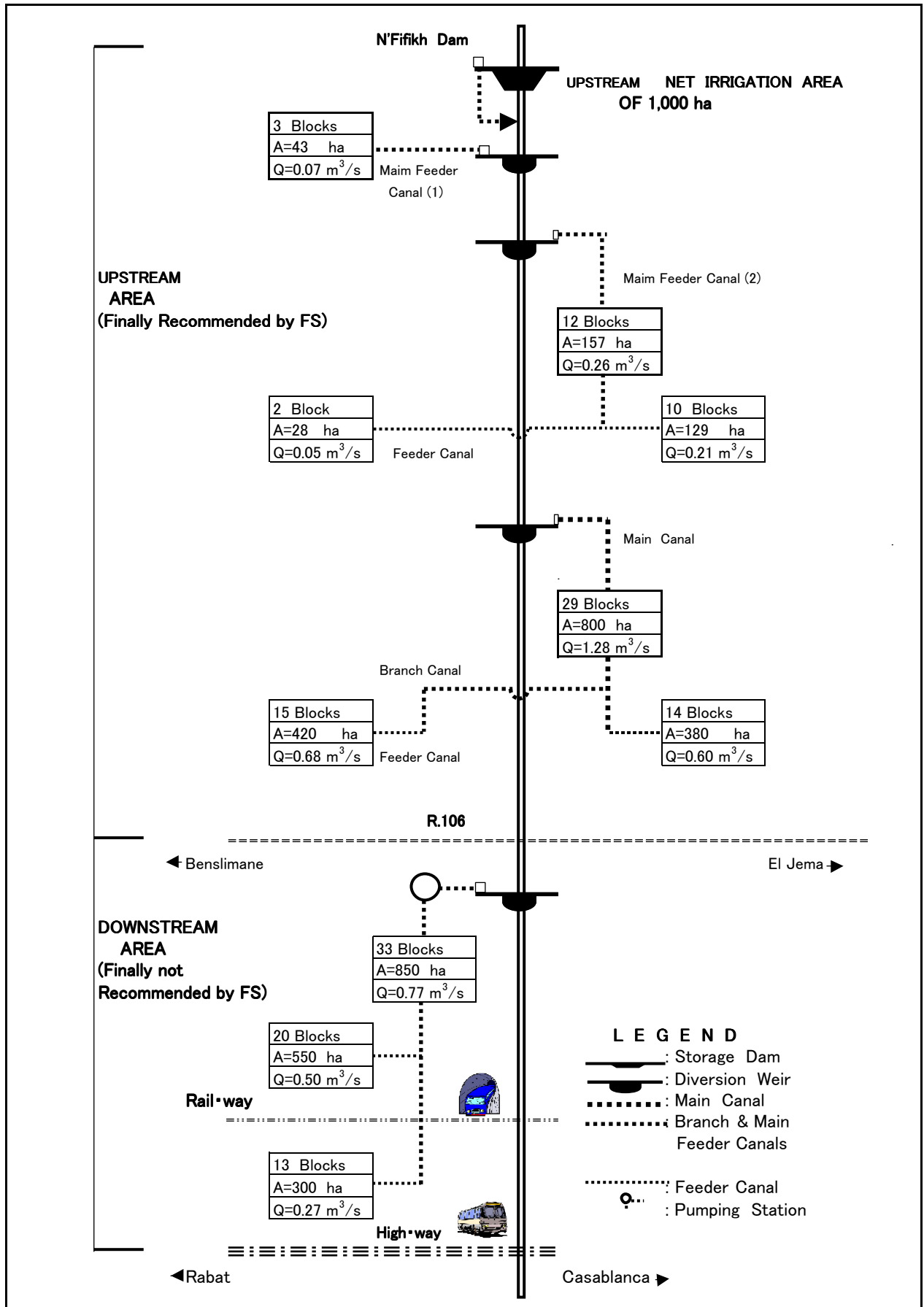

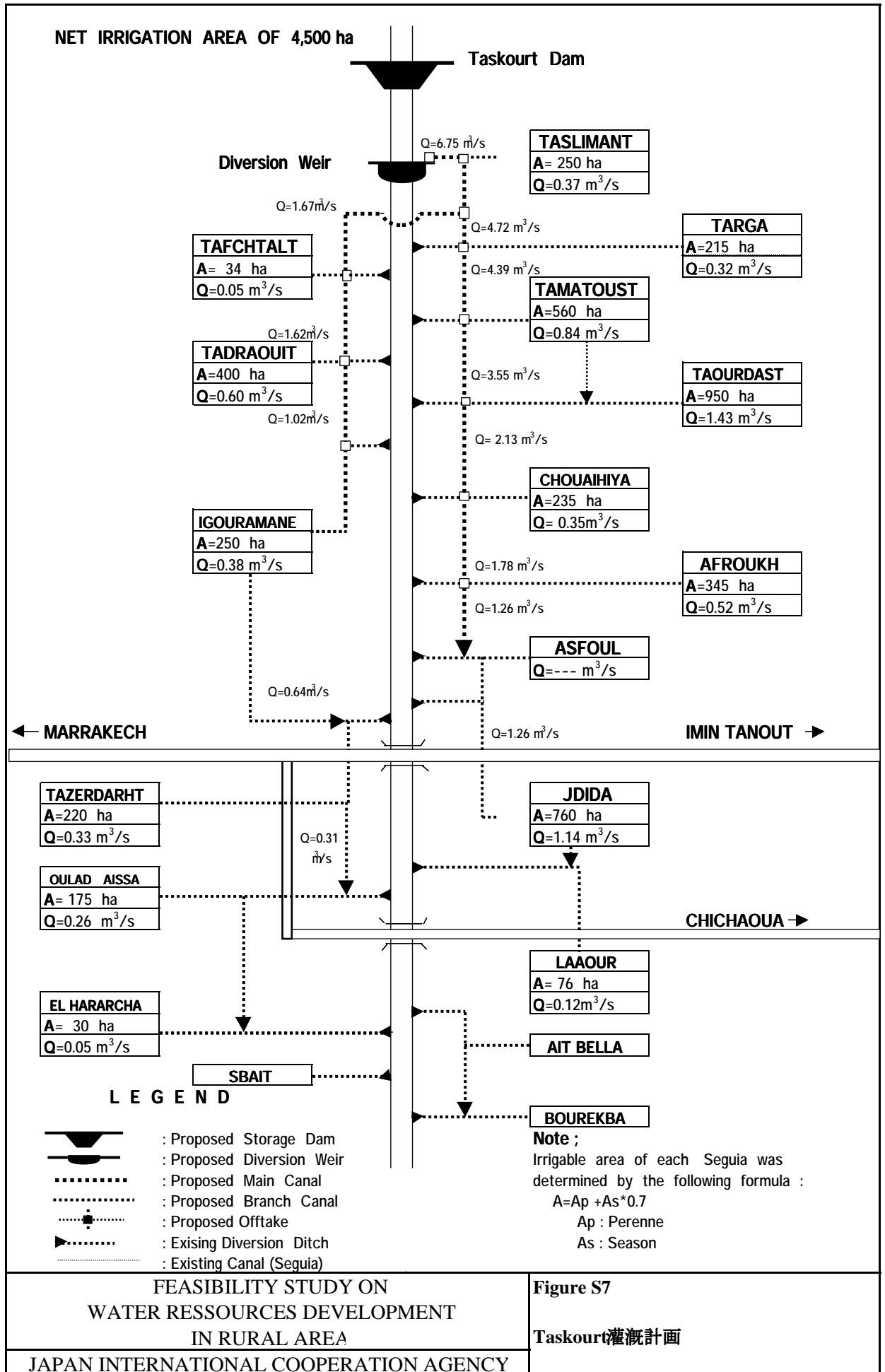
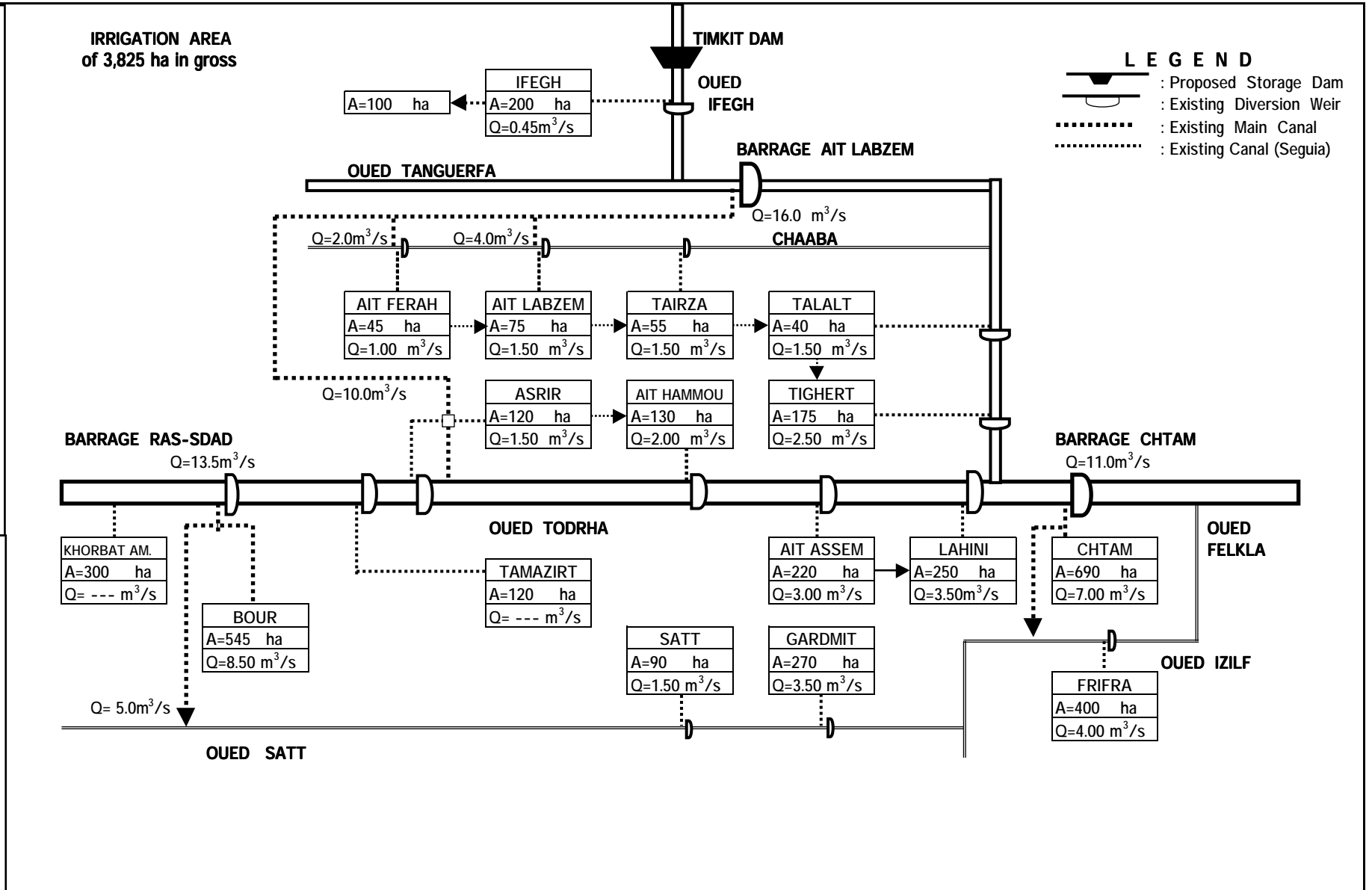
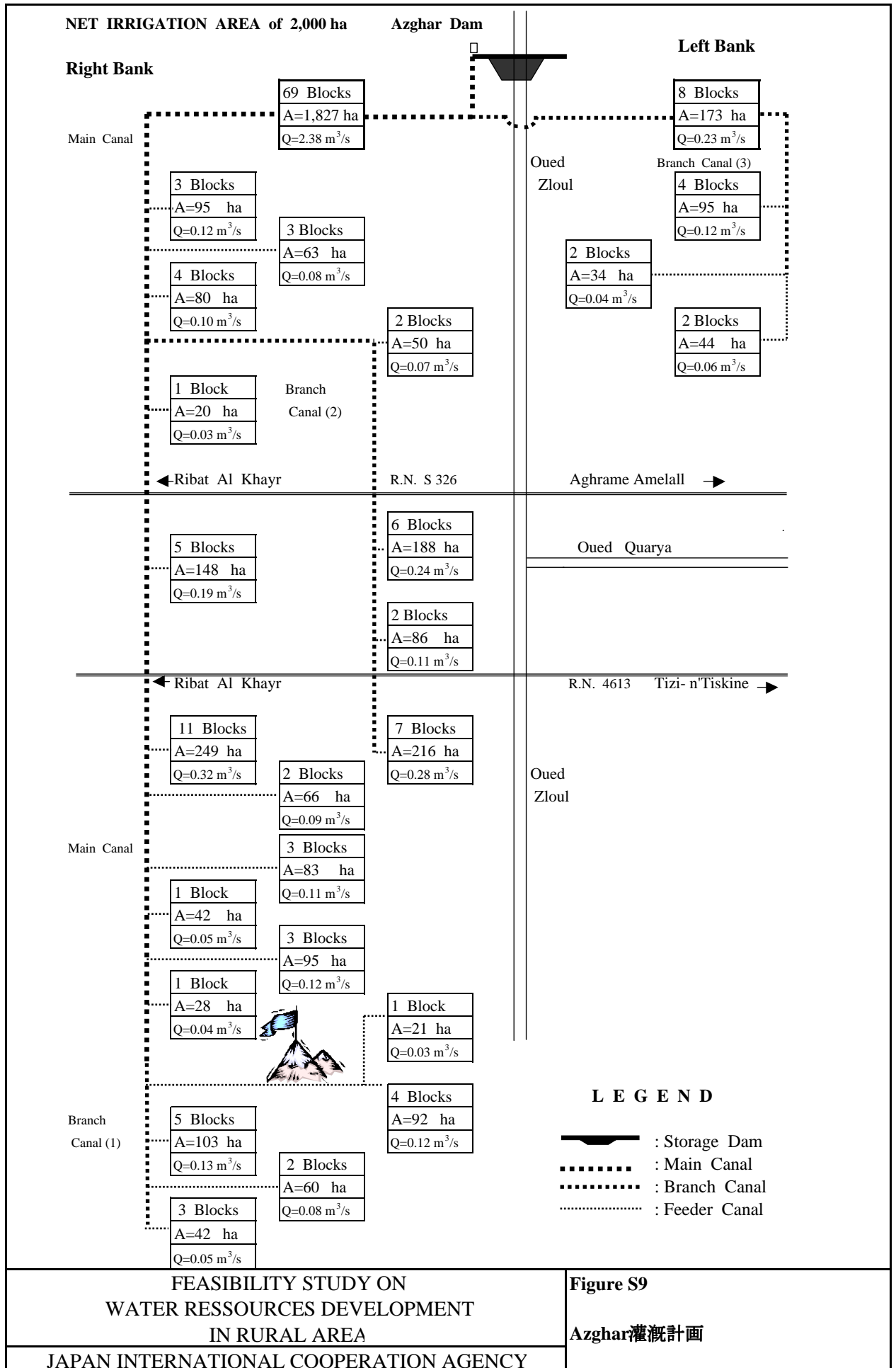

Figure S8  
 Timiki灌漑計画





JAPAN INTERNATIONAL COOPERATION AGENCY WATER RESOURCES DEVELOPMENT IN RURAL AREA FEASIBILITY STUDY ON																									
		Items	2000	01	02	03	04	05	06	07	08	09	10	11	12	13	14	15	16	17	18	19	20		
Figure S10 中規模ダム、全体実施予定		<b>I. First Step (Short Term):</b> <b>Implementation for Group A Projects</b> (1) Completion of feasibility study for (4 projects) (2) Detailed Design (D.D) of the above (3) Tendering for No. 9 Taskourt Project (4) Construction of No. 9 Taskourt Project (5) Tendering for remaining 3 projects of the above (No. 5 N'Fifikh, No. 10 Timkit and No. 17 Azghar) (6) Construction of the above 3 projects	Aug	Aug																					
					Jan	Dec																			
						Oct	Sep																		
							Dec					Nov													
								Feb	Jan																
										Apr		Sep													
						Dec	July																		
								Aug								Nov									
								(FS)								(Const)									
										Dec											Nov				
								(MP)											(Const)				Nov		
													Dec						(Const)					Nov	
													(MP)											(Const)	
		Remarks: 1) FS: Feasibility Study 2) MP: Master Plan Study 3) Const: Construction																							

