

TYPICAL CROSS SECTION OF ROAD:

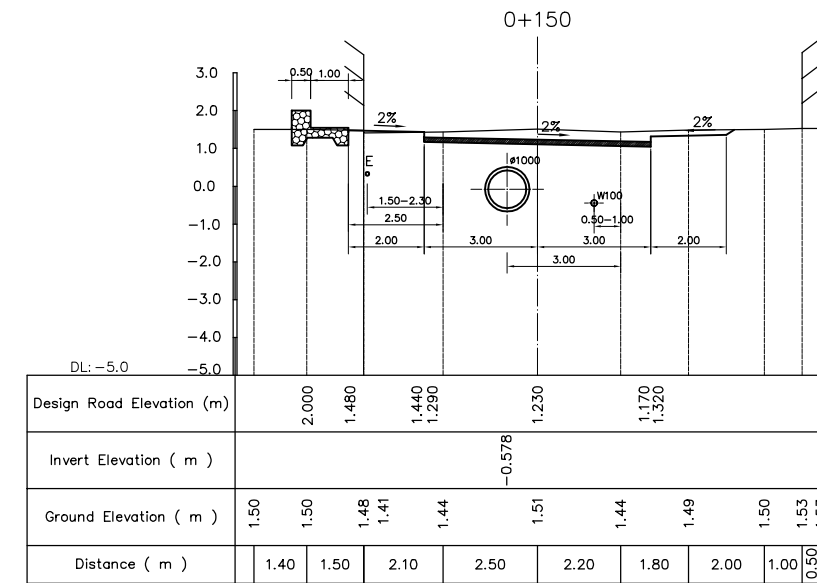

DETAIL 1:

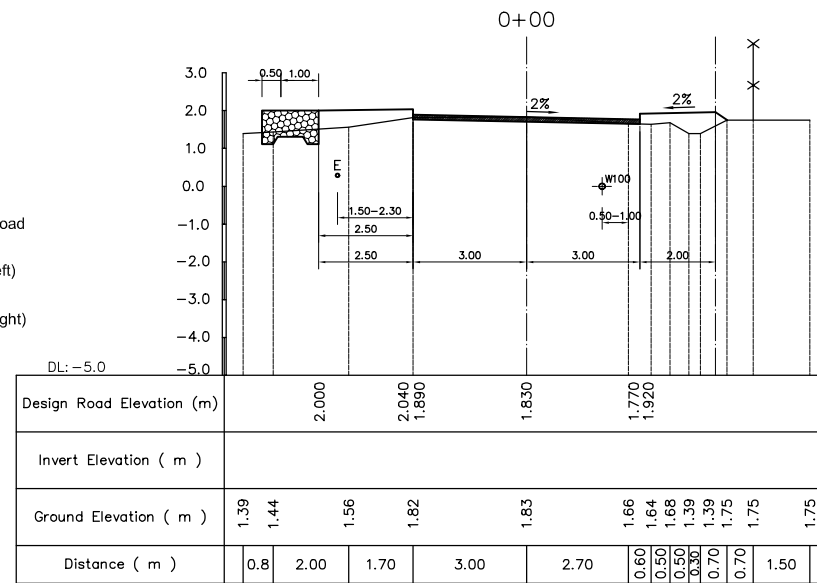
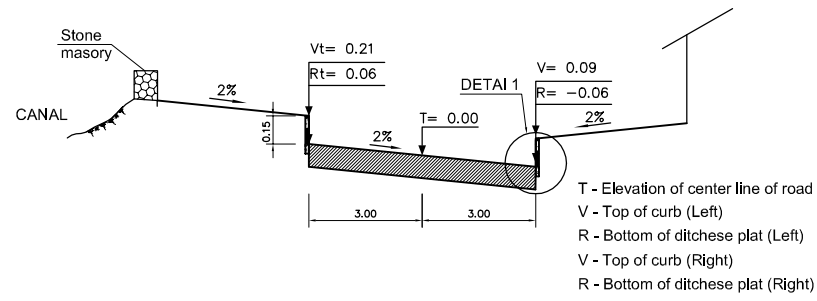
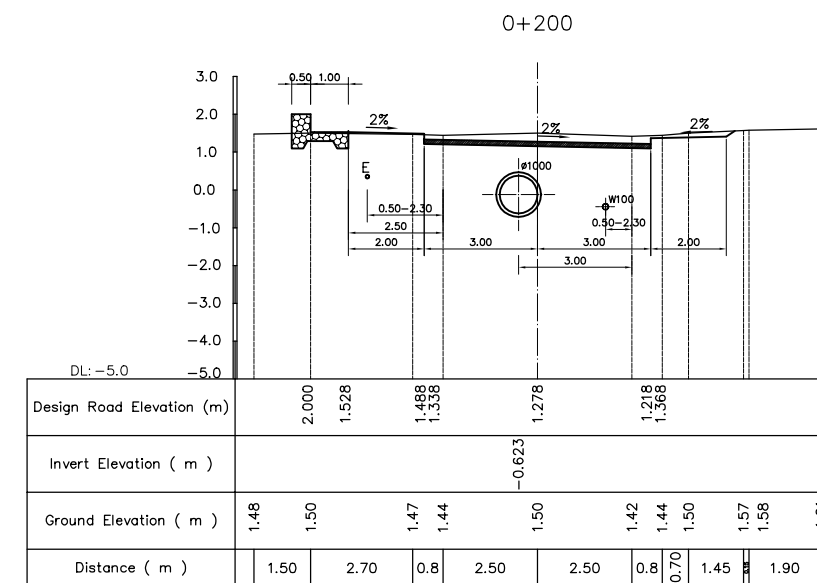
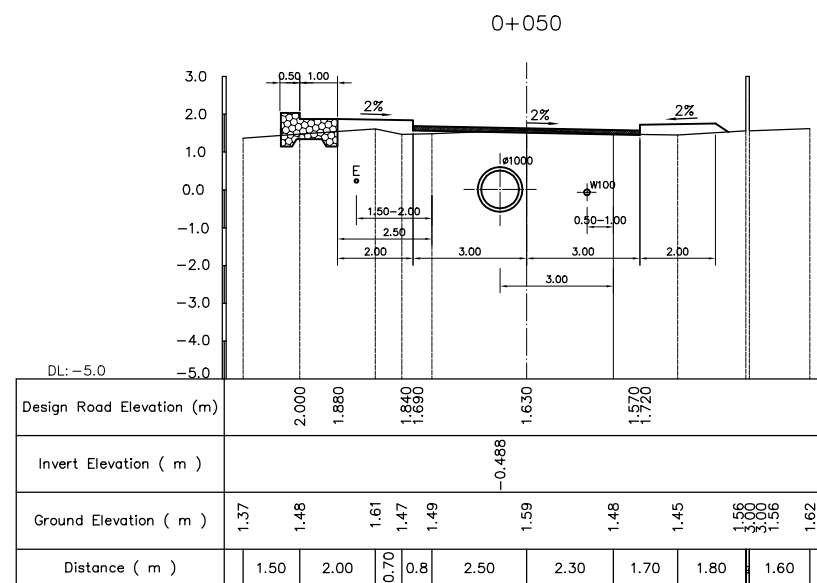
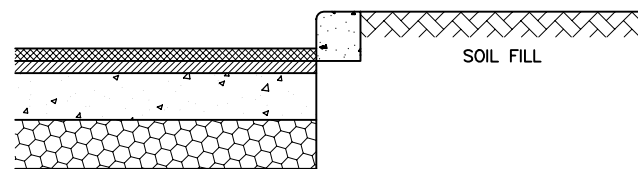

TYPICAL ROAD SURFACE:

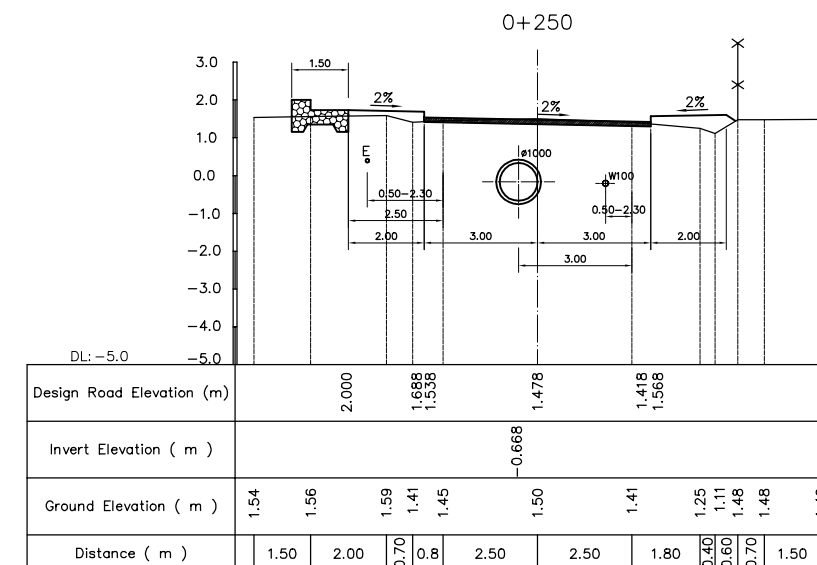
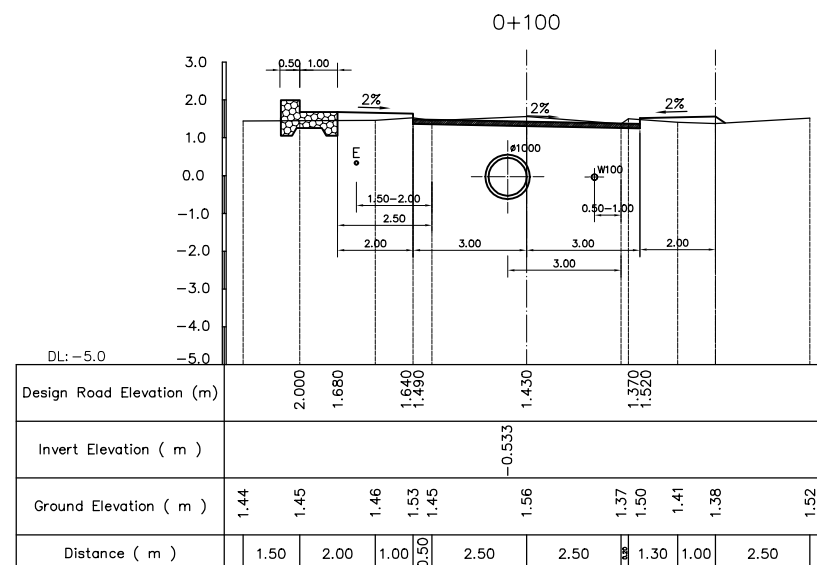
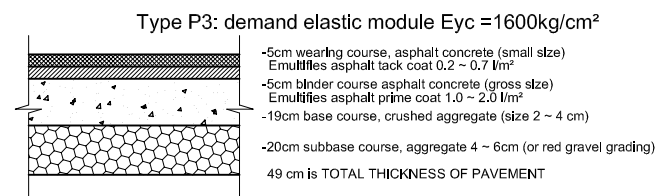

KEY MAP

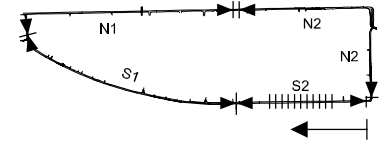

LEGEND

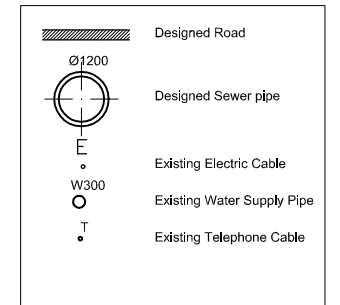

NO.	DATE	DESCRIPTIONS	BY	APRO.
REVISIONS				
PROJECT MANAGEMENT UNIT FOR HO CHI MINH CITY WATER ENVIRONMENT IMPROVEMENT				
THE DETAILED DESIGN STUDY ON HO CHI MINH CITY WATER ENVIRONMENT IMPROVEMENT PROJECT IN THE SOCIALIST REPUBLIC OF VIET NAM				
PACKAGE B PUMP DRAINAGE IMPROVEMENT BEN ME COC (2) AREA CROSS SECTION OF SEWER, ROAD AND TEMPORARY DIKE (14) BM2 S-2				
SCALE = 1 : 100				
JICA JAPAN INTERNATIONAL COOPERATION AGENCY (JICA)				
PACIFIC CONSULTANTS INTERNATIONAL				
DESIGNED		CHECKED		
DATE :		DWG. No. PB - PDI - BMC2 - 231		

KEY MAP

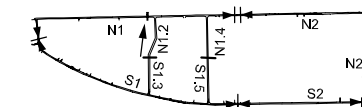

LEGEND

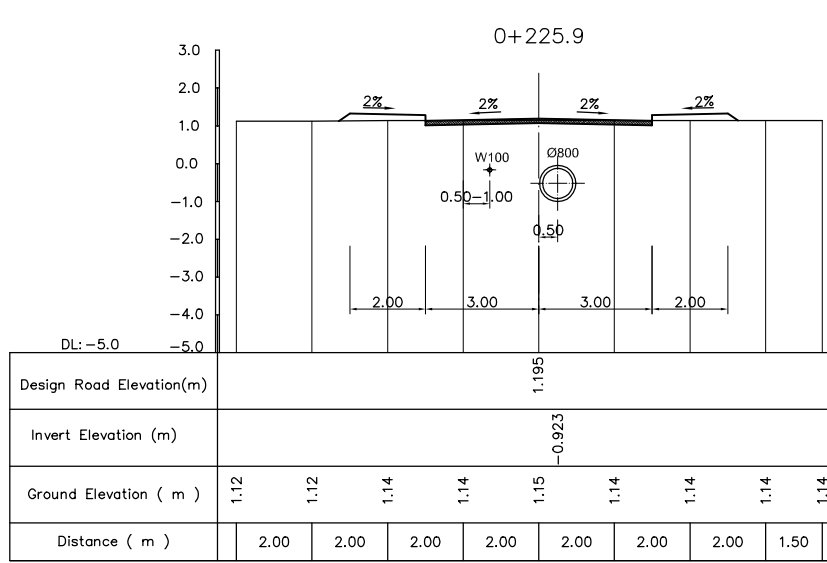
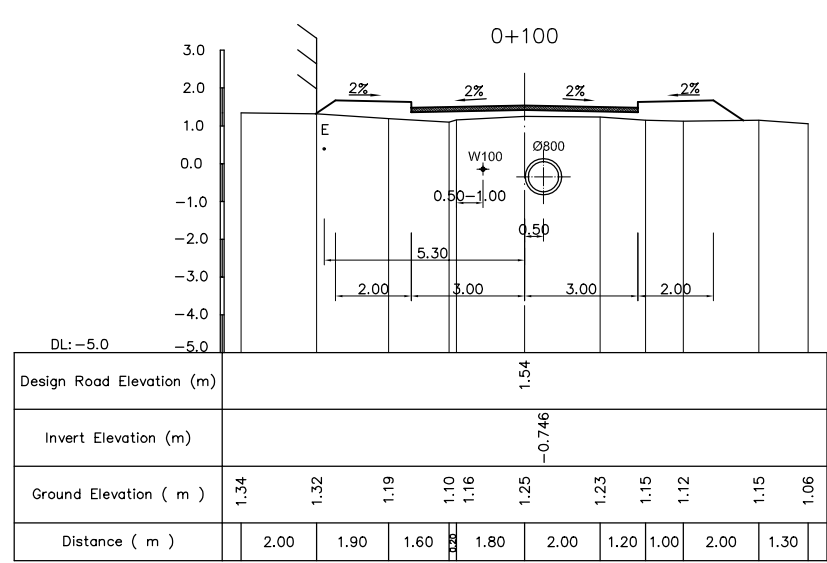
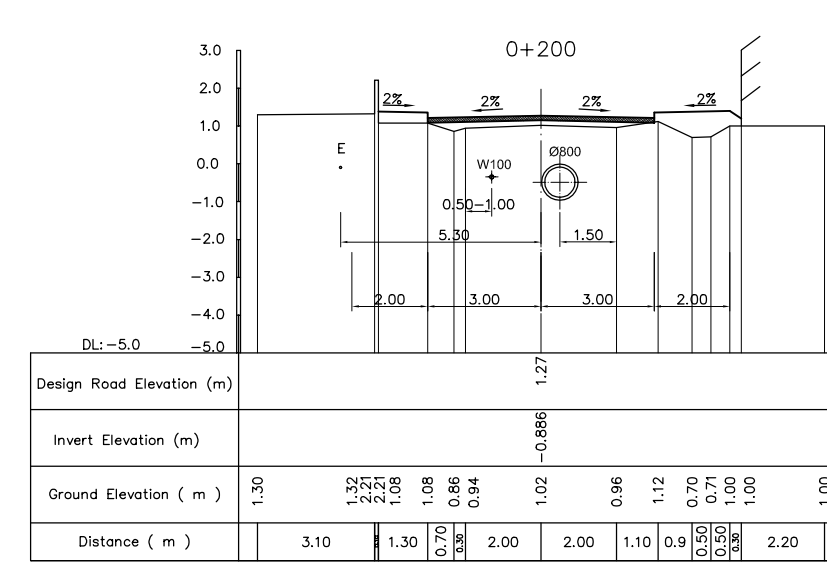
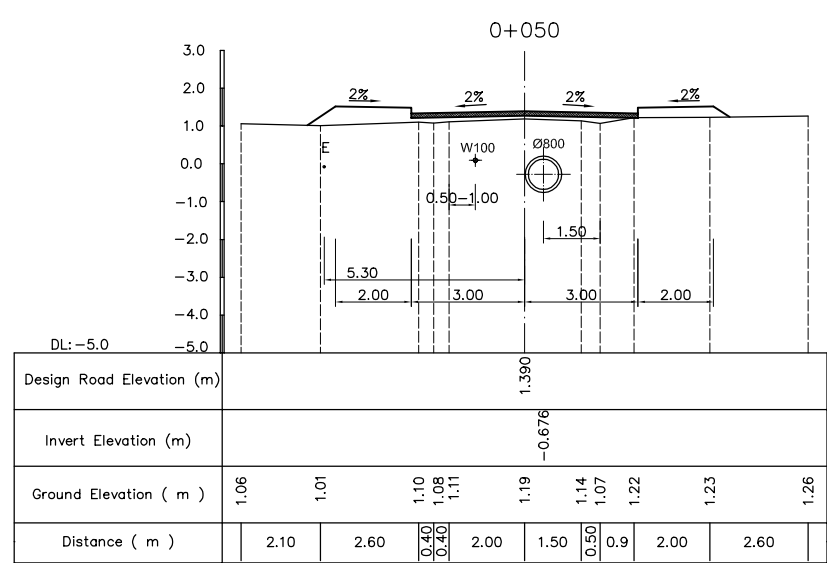
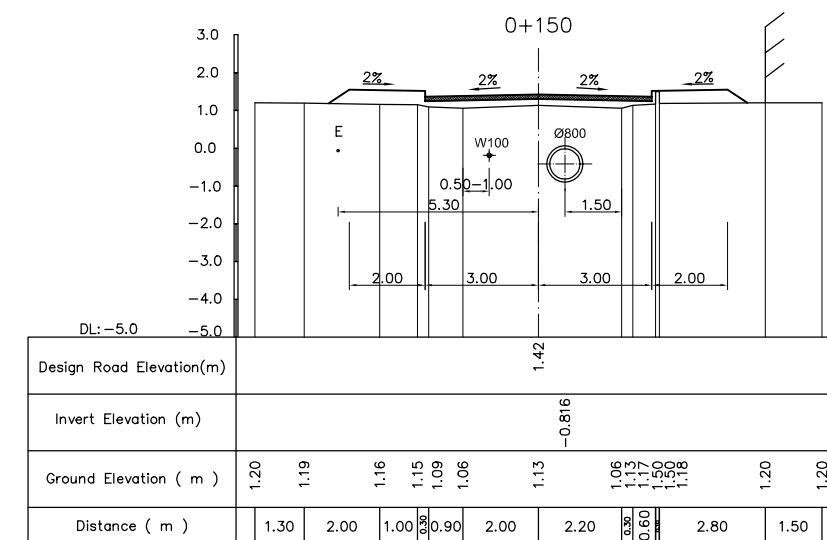
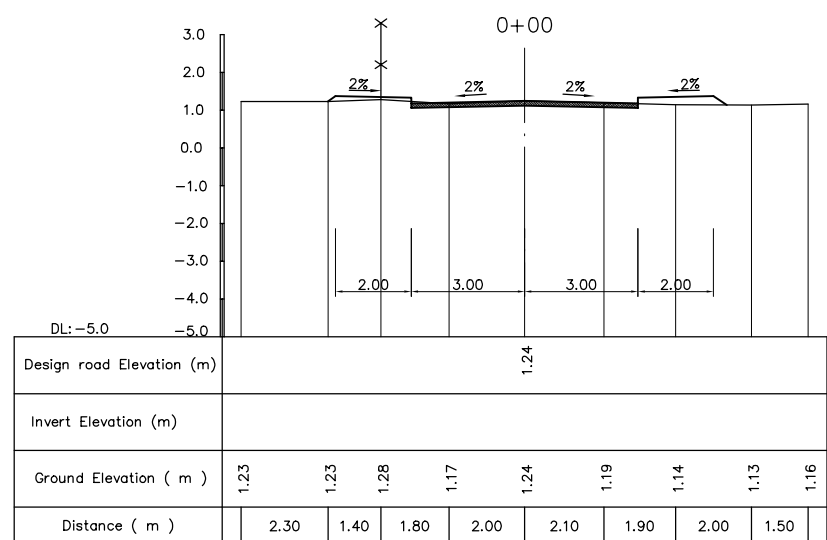
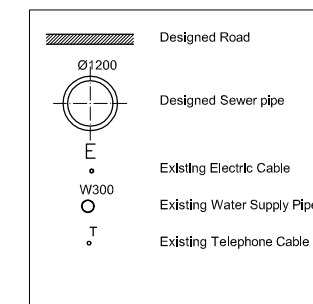

NO.	DATE	DESCRIPTIONS	BY	APRO.
REVISIONS				
PROJECT MANAGEMENT UNIT FOR HO CHI MINH CITY WATER ENVIRONMENT IMPROVEMENT				
THE DETAILED DESIGN STUDY ON HO CHI MINH CITY WATER ENVIRONMENT IMPROVEMENT PROJECT IN THE SOCIALIST REPUBLIC OF VIET NAM				
PACKAGE B PUMP DRAINAGE IMPROVEMENT BEN ME COC (2) AREA CROSS SECTION OF SEWER, ROAD AND TEMPORARY DIKE (16) BM2 N-1.2				
SCALE = 1 : 100				
JAPAN INTERNATIONAL COOPERATION AGENCY (JICA)				
PACIFIC CONSULTANTS INTERNATIONAL				
DESIGNED		CHECKED		
DATE :		DWG. No. PB - PDI - BMC2 - 233		

KEY MAP

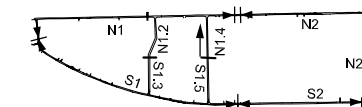

LEGEND

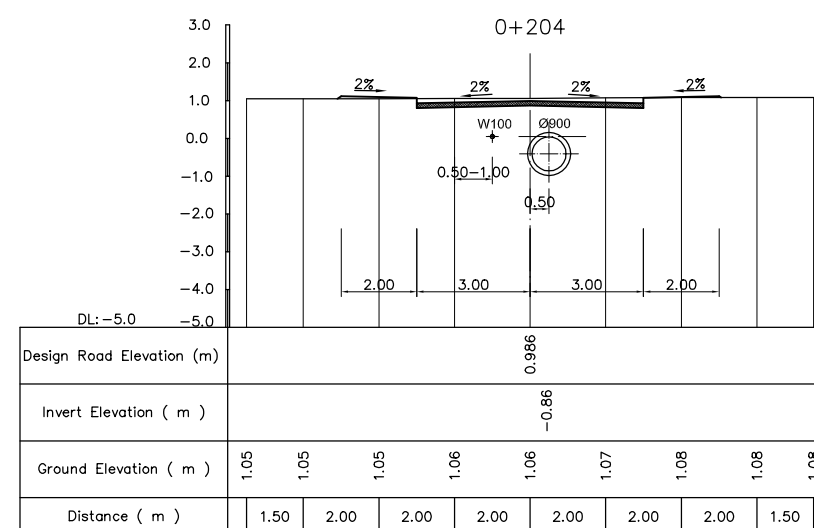
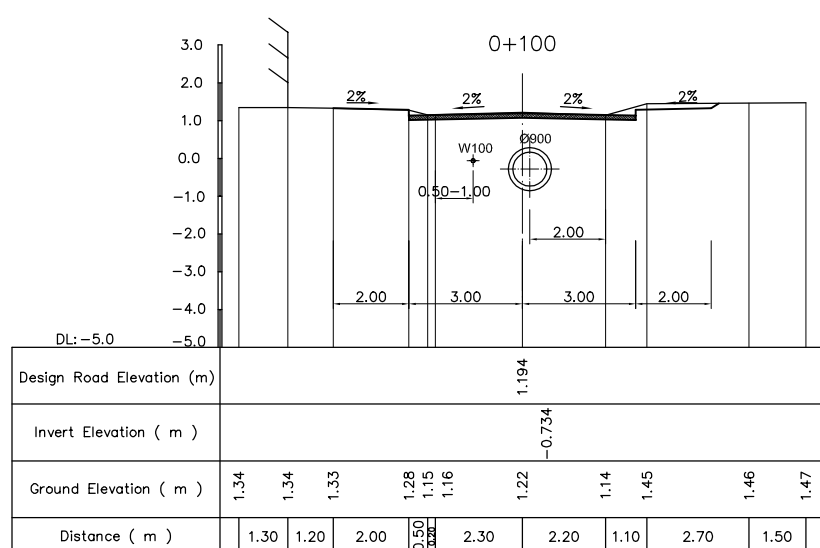
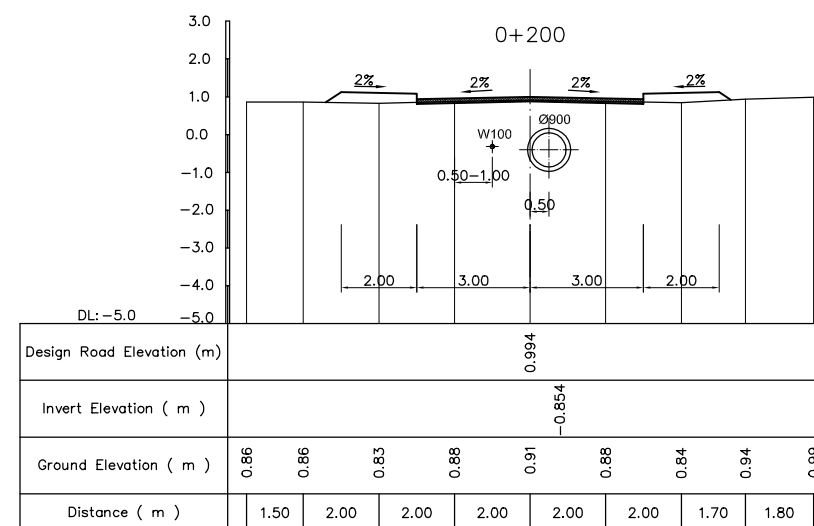
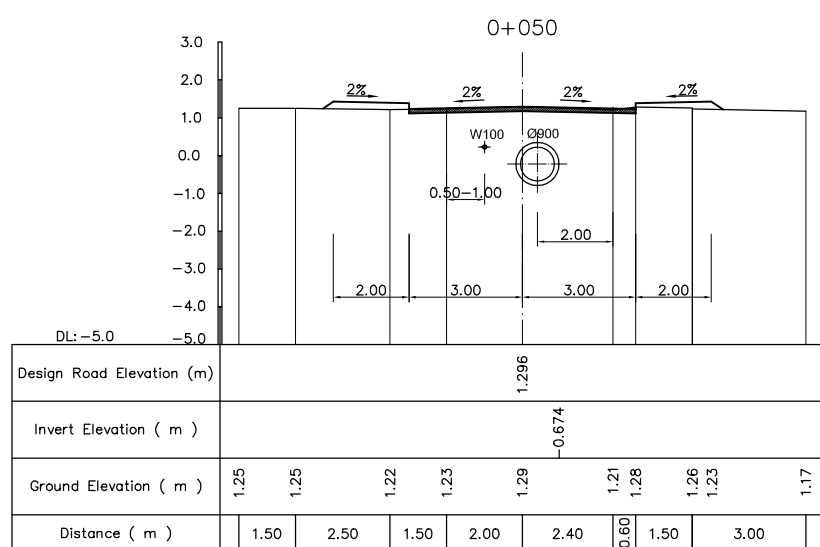
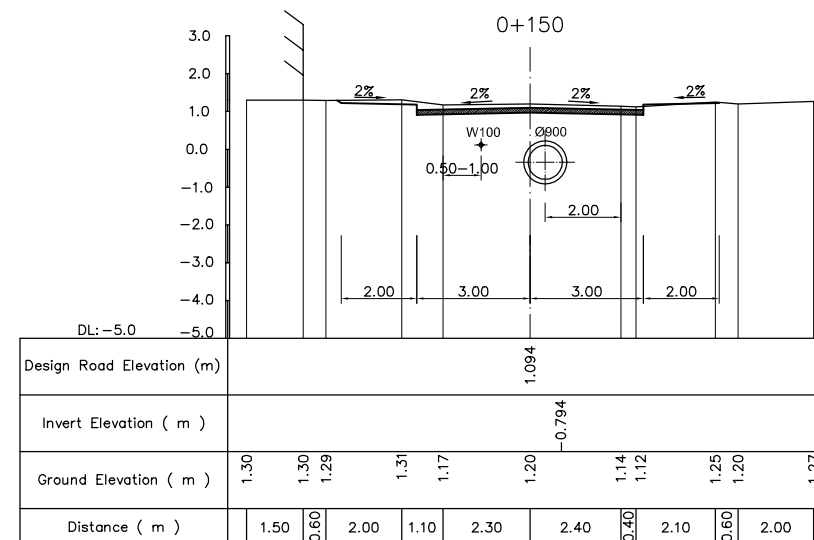
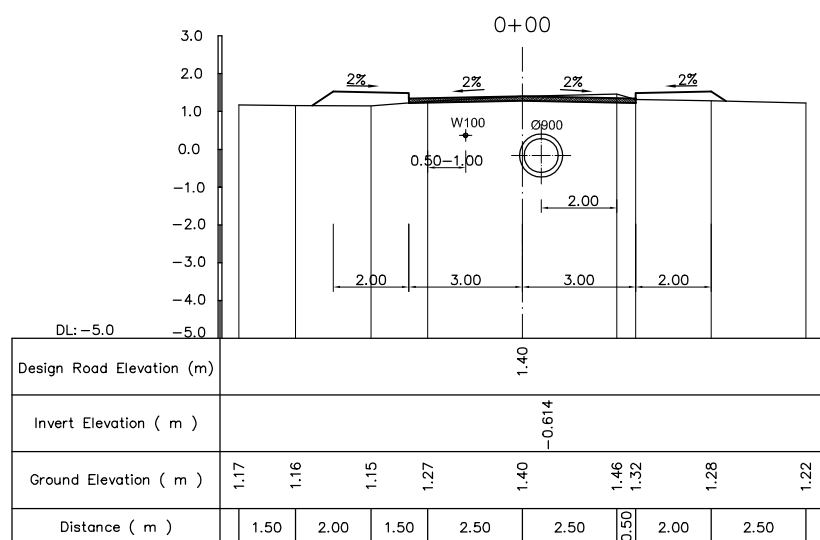
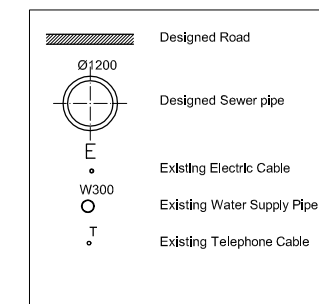

NO.	DATE	DESCRIPTIONS	BY	APRO.

REVISIONS

PROJECT MANAGEMENT UNIT FOR
HO CHI MINH CITY
WATER ENVIRONMENT IMPROVEMENT

THE DETAILED DESIGN STUDY ON HO CHI MINH CITY
WATER ENVIRONMENT IMPROVEMENT PROJECT
IN THE SOCIALIST REPUBLIC OF VIET NAM

PACKAGE B
PUMP DRAINAGE IMPROVEMENT
BEN ME COC (2) AREA
CROSS SECTION OF SEWER,
ROAD AND TEMPORARY DIKE (17)
BM2 N-1.4

SCALE = 1 : 100

JICA JAPAN INTERNATIONAL COOPERATION
AGENCY (JICA)

PACIFIC CONSULTANTS INTERNATIONAL

DESIGNED CHECKED

DATE : DWG. No. PB - PDI - BMC2 - 234

KEY MAP

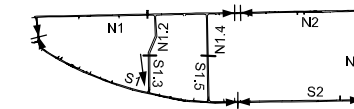

LEGEND

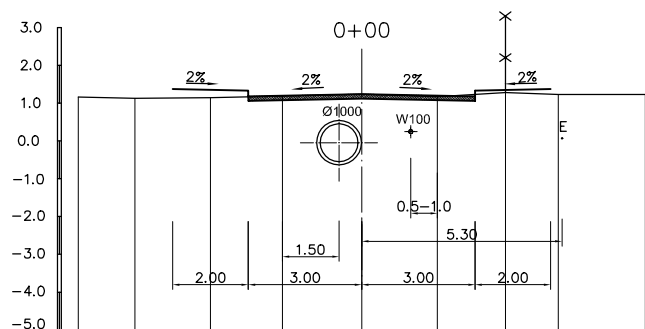
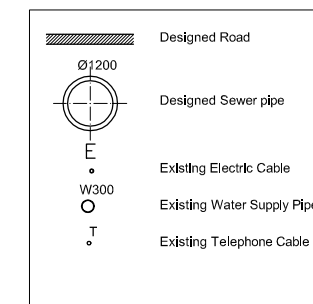

DL: -5.0								
Design Road Elevation (m)	1.24							
Invert Elevation (m)	-0.546							
Ground Elevation (m)	1.16	1.13	1.14	1.19	1.24	1.17	1.28	1.23
Distance (m)	1.50	2.00	1.90	2.10	2.00	1.80	1.40	2.30

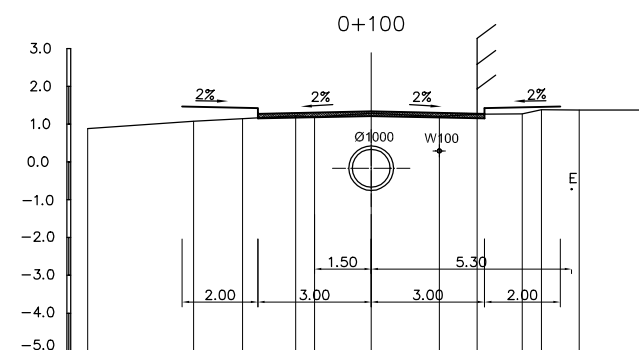

DL: -5.0											
Design Road Elevation (m)	1.335										
Invert Elevation (m)	-0.665										
Ground Elevation (m)	0.88	1.08	1.14	1.22	1.19	1.29	1.20	1.26	1.27	1.38	1.37
Distance (m)	2.80	1.30	1.40	0.50	1.50	1.80	1.00	1.20	0.50	1.00	2.00

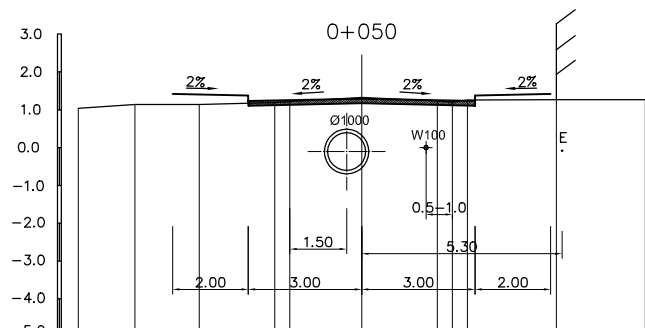

DL: -5.0									
Design Road Elevation (m)	1.29								
Invert Elevation (m)	-0.605								
Ground Elevation (m)	1.04	1.14	1.14	1.19	1.22	1.33	1.23	1.20	1.26
Distance (m)	1.50	1.70	2.00	0.40	1.90	2.00	0.40	2.35	2.35

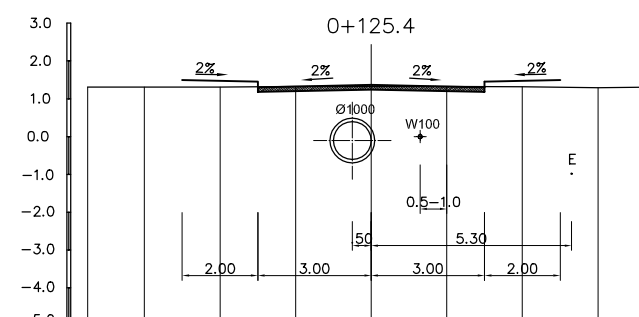

DL: -5.0									
Design Road Elevation (m)	1.365								
Invert Elevation (m)	-0.695								
Ground Elevation (m)	1.31	1.31	1.31	1.33	1.33	1.33	1.32	1.29	1.31
Distance (m)	1.50	2.00	2.00	2.00	2.00	2.00	2.00	2.00	1.50

NO.	DATE	DESCRIPTIONS	BY	APRO.
-----	------	--------------	----	-------

REVISIONS

PROJECT MANAGEMENT UNIT FOR
HO CHI MINH CITY
WATER ENVIRONMENT IMPROVEMENT

THE DETAILED DESIGN STUDY ON HO CHI MINH CITY
WATER ENVIRONMENT IMPROVEMENT PROJECT
IN THE SOCIALIST REPUBLIC OF VIET NAM

PACKAGE B
PUMP DRAINAGE IMPROVEMENT
BEN ME COC (2) AREA
CROSS SECTION OF SEWER,
ROAD AND TEMPORARY DIKE (18)
BM2 S - 1.3

SCALE = 1 : 100

JICA JAPAN INTERNATIONAL COOPERATION
AGENCY (JICA)

PACIFIC CONSULTANTS INTERNATIONAL

DESIGNED CHECKED

DATE : DWG. No. PB - PDI - BMC2 - 235

KEY MAP

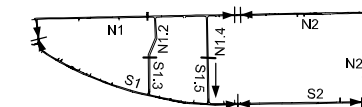

LEGEND

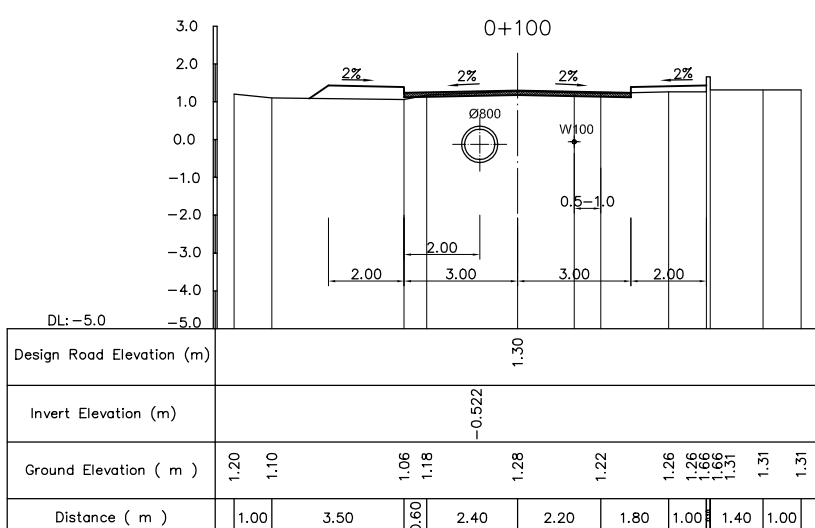
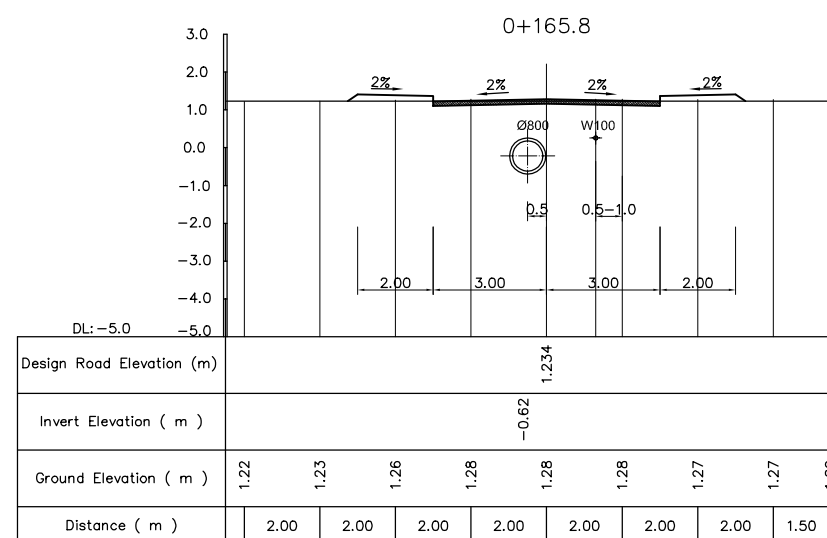
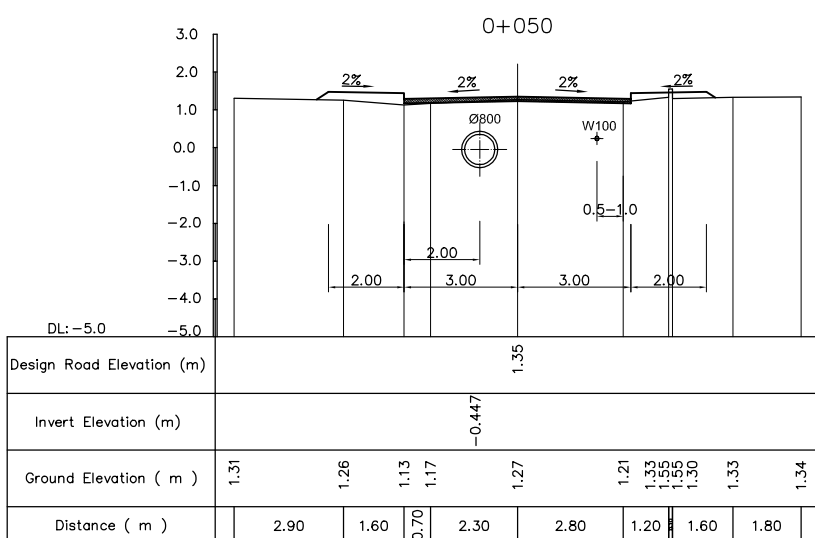
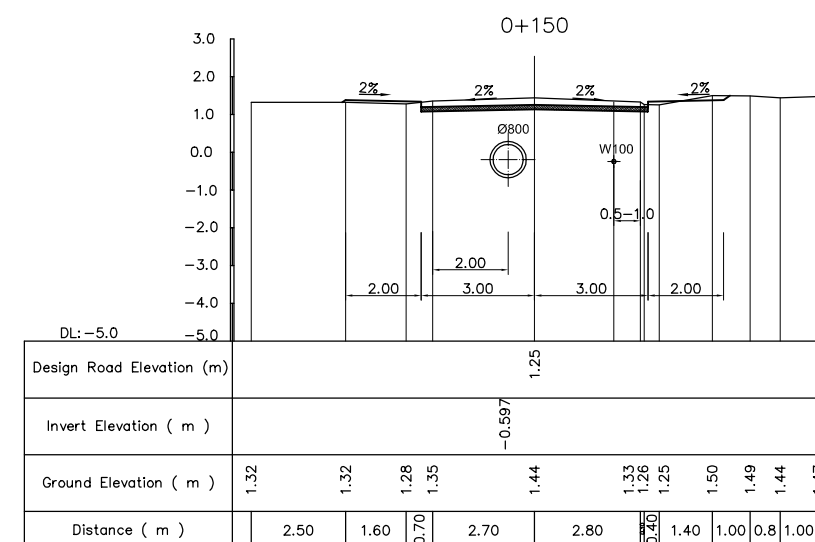
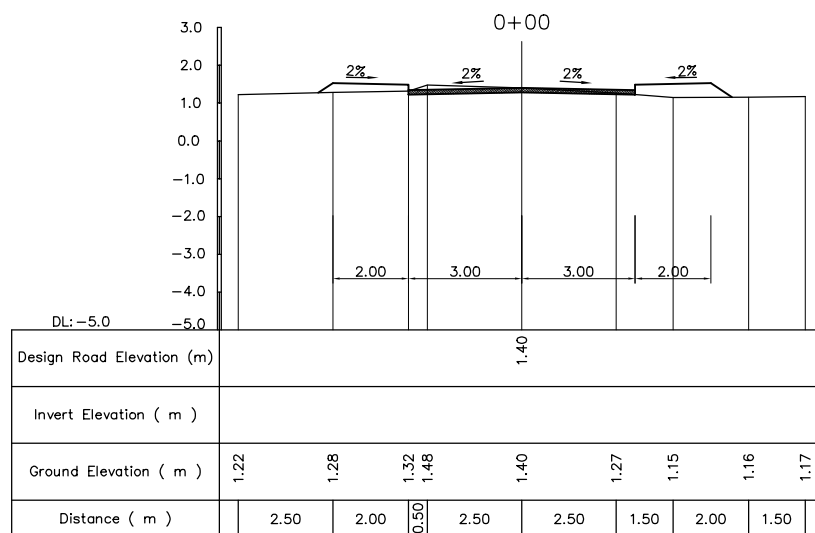
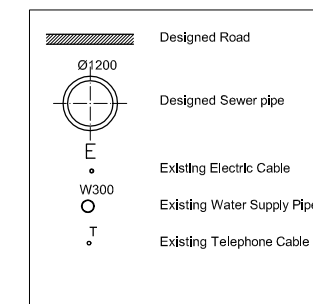

NO.	DATE	DESCRIPTIONS	BY	APRO.
-----	------	--------------	----	-------

REVISIONS

PROJECT MANAGEMENT UNIT FOR
HO CHI MINH CITY
WATER ENVIRONMENT IMPROVEMENT

THE DETAILED DESIGN STUDY ON HO CHI MINH CITY
WATER ENVIRONMENT IMPROVEMENT PROJECT
IN THE SOCIALIST REPUBLIC OF VIET NAM

PACKAGE B
PUMP DRAINAGE IMPROVEMENT
BEN ME COC (2) AREA
CROSS SECTION OF SEWER,
ROAD AND TEMPORARY DIKE (19)
BM2 S - 1.5

SCALE = 1 : 100

JICA JAPAN INTERNATIONAL COOPERATION
AGENCY (JICA)

PACIFIC CONSULTANTS INTERNATIONAL

DESIGNED CHECKED

DATE : DWG. No. PB - PDI - BMC2 - 236

ALONG BM2-N1.1, N1.3, N1.5, N2.3, N2.2

(Based on the design of waterway management section)

TYPE C

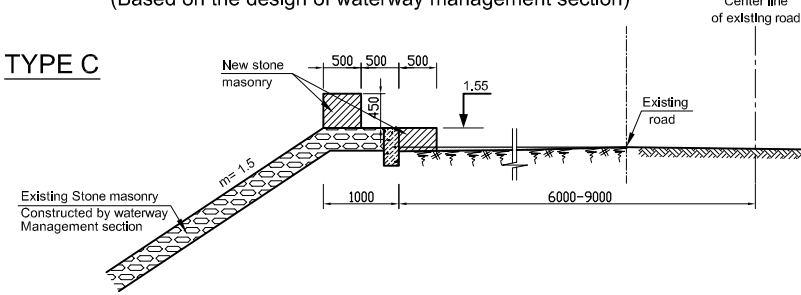

ALONG BM2 -N2.1

TYPE A

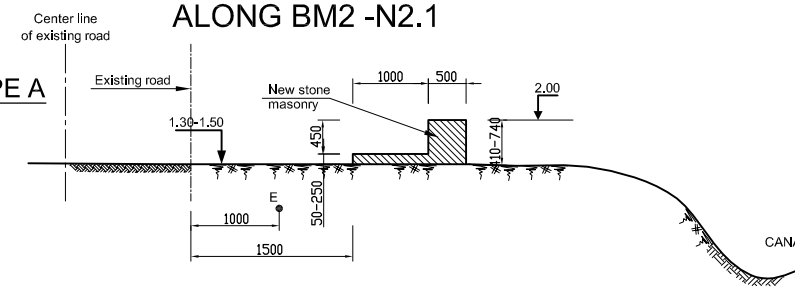

ALONG BM2 -S1.1, 1.4, 1.6

TYPE A

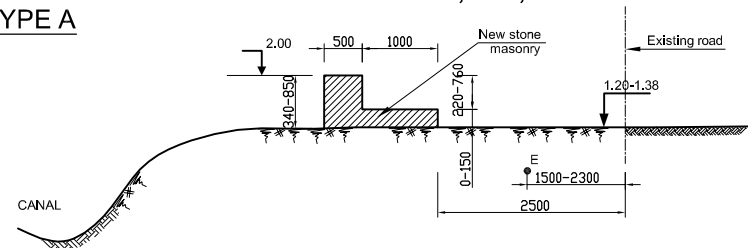

ALONG BM2 -S2.1, S2.2

TYPE A

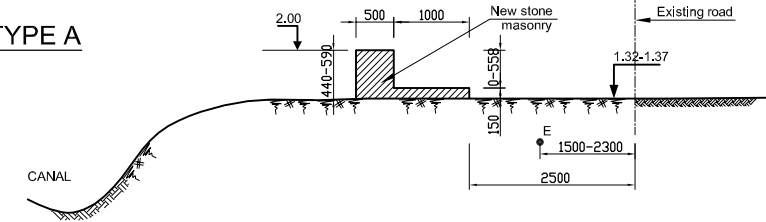

TYPE A:

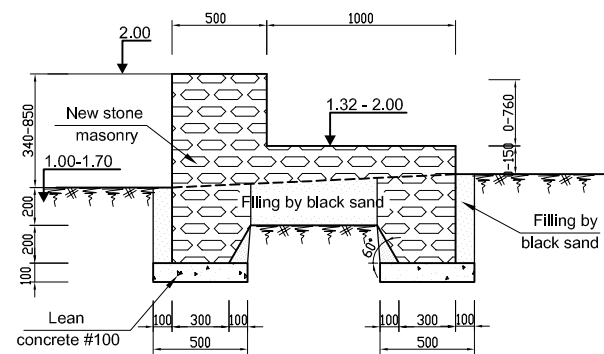

TYPE	VOLUME OF (PER 1m LONG) (Unit: m3)			
	Excavation	Sandy soil back filling	Leveling concrete	Stone Masory
A	0.71	0.257	0.1	0.81
C	0.2	0.05		0.375

TYPE C

Scale: 1/20

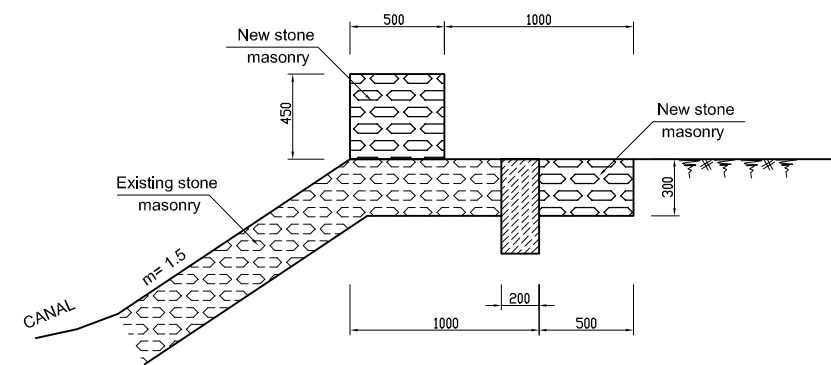

TYPE	VOLUME OF TEMPORARY DIKE (Unit: m3)				
	Length (m)	Excavation	Sandy soil back filling	Levelling concrete	Stone Masory
A	2019	1433	519	202	1635
C	1467	293	73		550

NO.	DATE	DESCRIPTIONS	BY	APRO.
REVISIONS				
PROJECT MANAGEMENT UNIT FOR HO CHI MINH CITY WATER ENVIRONMENT IMPROVEMENT				
THE DETAILED DESIGN STUDY ON HO CHI MINH CITY WATER ENVIRONMENT IMPROVEMENT PROJECT IN THE SOCIALIST REPUBLIC OF VIET NAM				
PACKAGE B PUMP DRAINAGE IMPROVEMENT BEN ME COC (2) AREA TYPICAL CROSS SECTION AND DETAILS OF TEMPORARY DIKE				
SCALE :				
DESIGNED		CHECKED		
DATE :		DWG. No.PB -PDI- BMC2 -237		

JICA JAPAN INTERNATIONAL COOPERATION AGENCY (JICA)

PACIFIC CONSULTANTS INTERNATIONAL

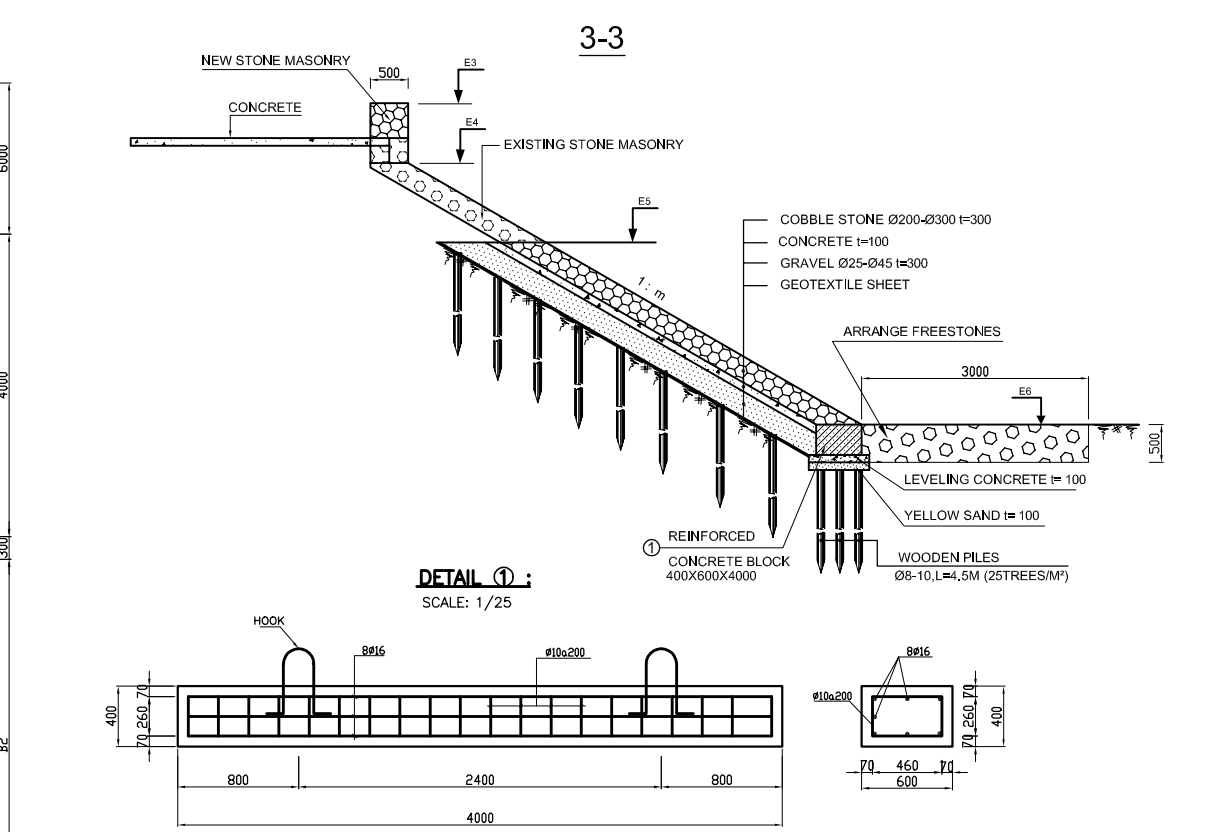
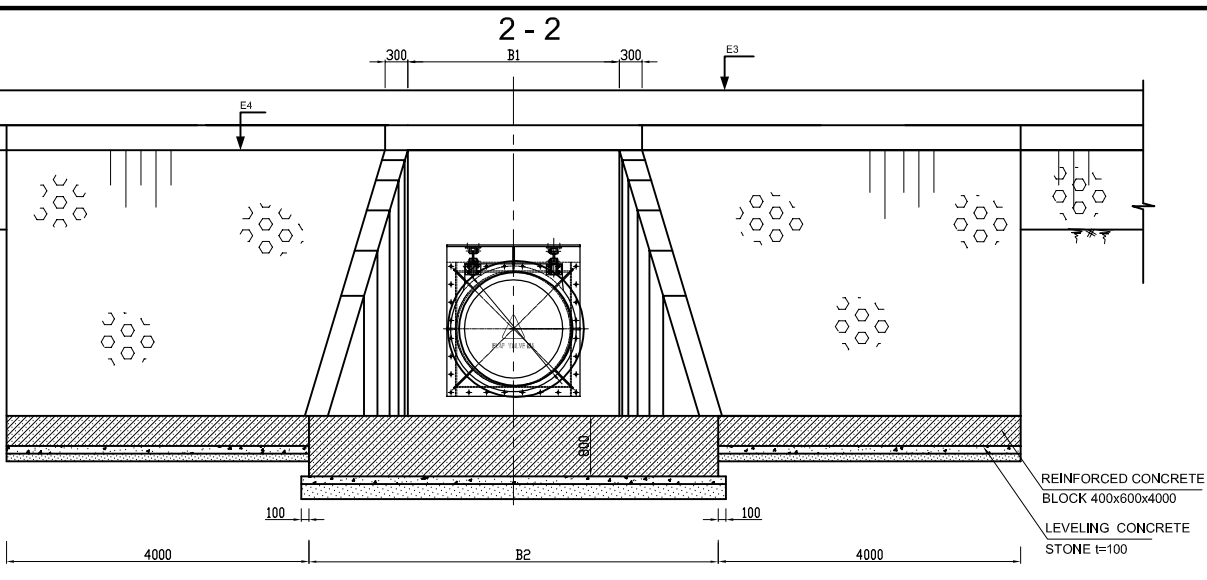
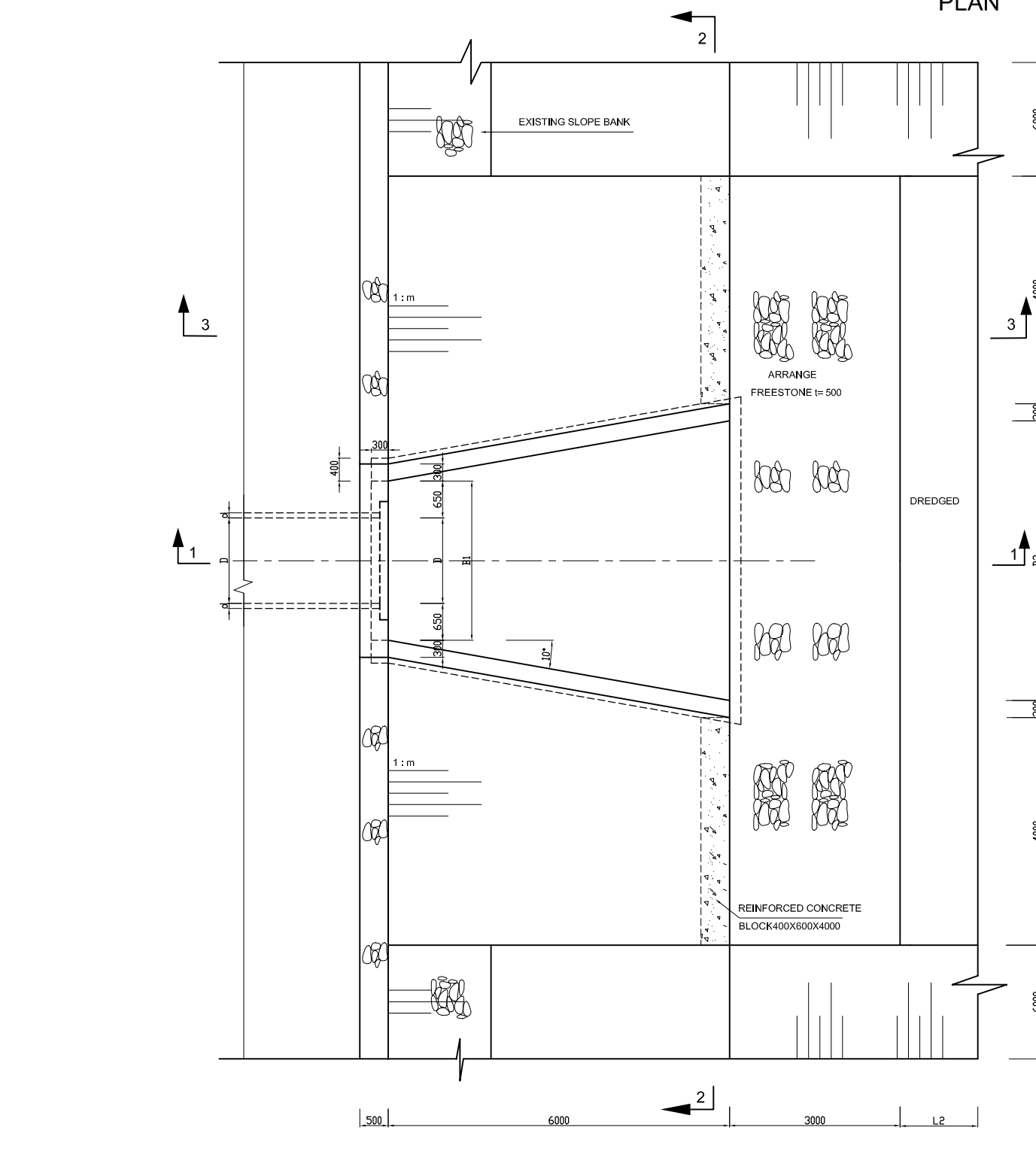
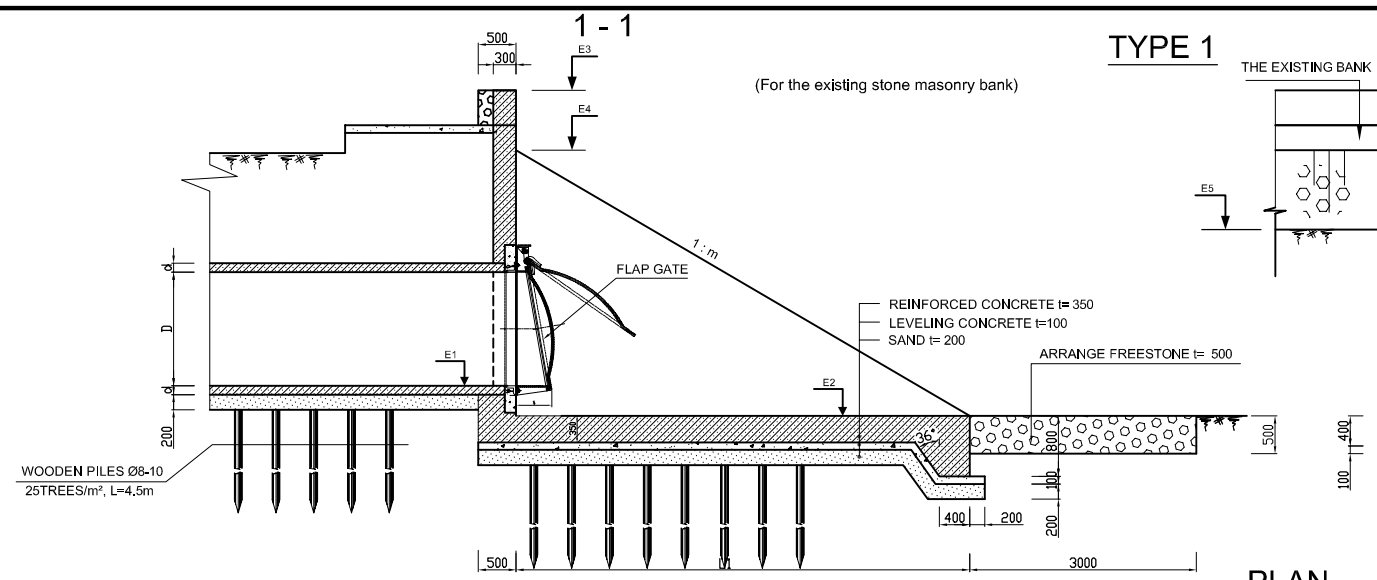

BEN ME COC 2

No	DIAMETER	POSITION	ELEVATION						m	H (m)	B1 (m)	B2 (m)	L1 (m)	L2 (m)
			E1	E2	E3	E4	E5	E6						
1	1000	N1-0+427.5	-0.967	-1.367	2.000	1.550	-1.350	-1.367	1.5	3.40	2.30	3.50	4.40	5.20
2	1500	N1-0+876	-1.964	-2.364	2.000	1.550	-1.350	-2.364	1.5	4.40	2.80	4.80	5.90	11.00
3	1500	N2-0+900	-1.962	-2.362	2.000	1.550	-1.350	-2.362	1.5	4.40	2.80	4.80	5.90	10.00
4	1200	N2-0+720	-1.470	-1.870	2.000	1.550	-1.350	-1.870	1.5	3.90	2.50	4.30	5.10	6.00
5	900	N2-0+205	-0.617	-1.017	2.000	1.550	-1.350	-1.017	1.5	3.00	2.20	3.60	3.90	12.00

LEGEND:

- E1: INVERT ELEVATION OF SEWER PIPE
- E2: ELEVATION OF OUTLET FLOOR
- E3: TOP ELEVATION OF OUTLET VERTICAL WALL
- E4: TOP ELEVATION OF OUTLET WING WALL
- E5: TOP ELEVATION OF ADDITIONAL STONE MASONRY
- E6: FOOT ELEVATION OF ADDITIONAL STONE MASONRY

NOTE:

DETAILS OF FLAP GATE REFERS TO PB - PDI - BMC1 - 405

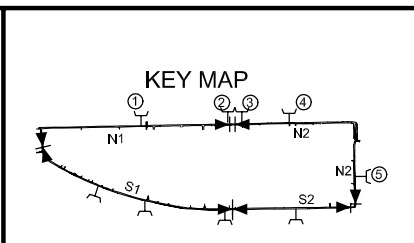

NO.	DATE	DESCRIPTIONS	BY	APRO.
REVISIONS				
PROJECT MANAGEMENT UNIT FOR HO CHI MINH CITY WATER ENVIRONMENT IMPROVEMENT				
THE DETAILED DESIGN STUDY ON HO CHI MINH CITY WATER ENVIRONMENT IMPROVEMENT PROJECT IN THE SOCIALIST REPUBLIC OF VIET NAM				
PACKAGE B PUMP DRAINAGE IMPROVEMENT BEN ME COC(2) AREA				
TYPICAL PLAN AND SECTION OF SEWER OUTLET (TYPE1)				
SCALE : 1 : 50				
JAPAN INTERNATIONAL COOPERATION AGENCY (JICA)				
PACIFIC CONSULTANTS INTERNATIONAL				
DESIGNED		CHECKED		
DATE :		DWG. No. PB - PDI - BMC2-238		

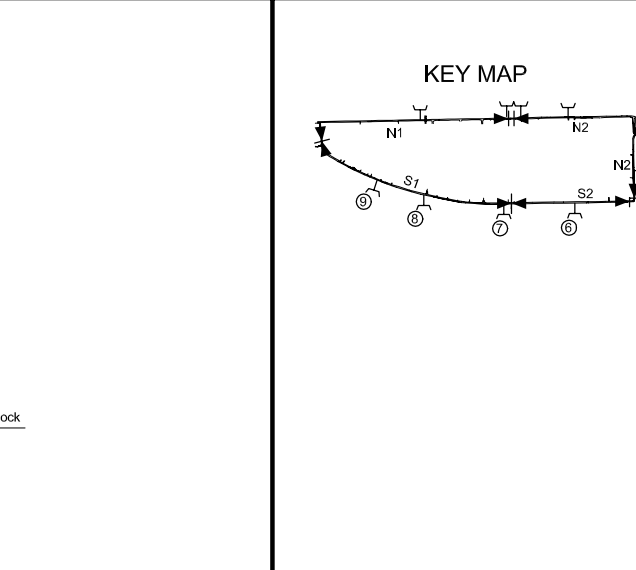
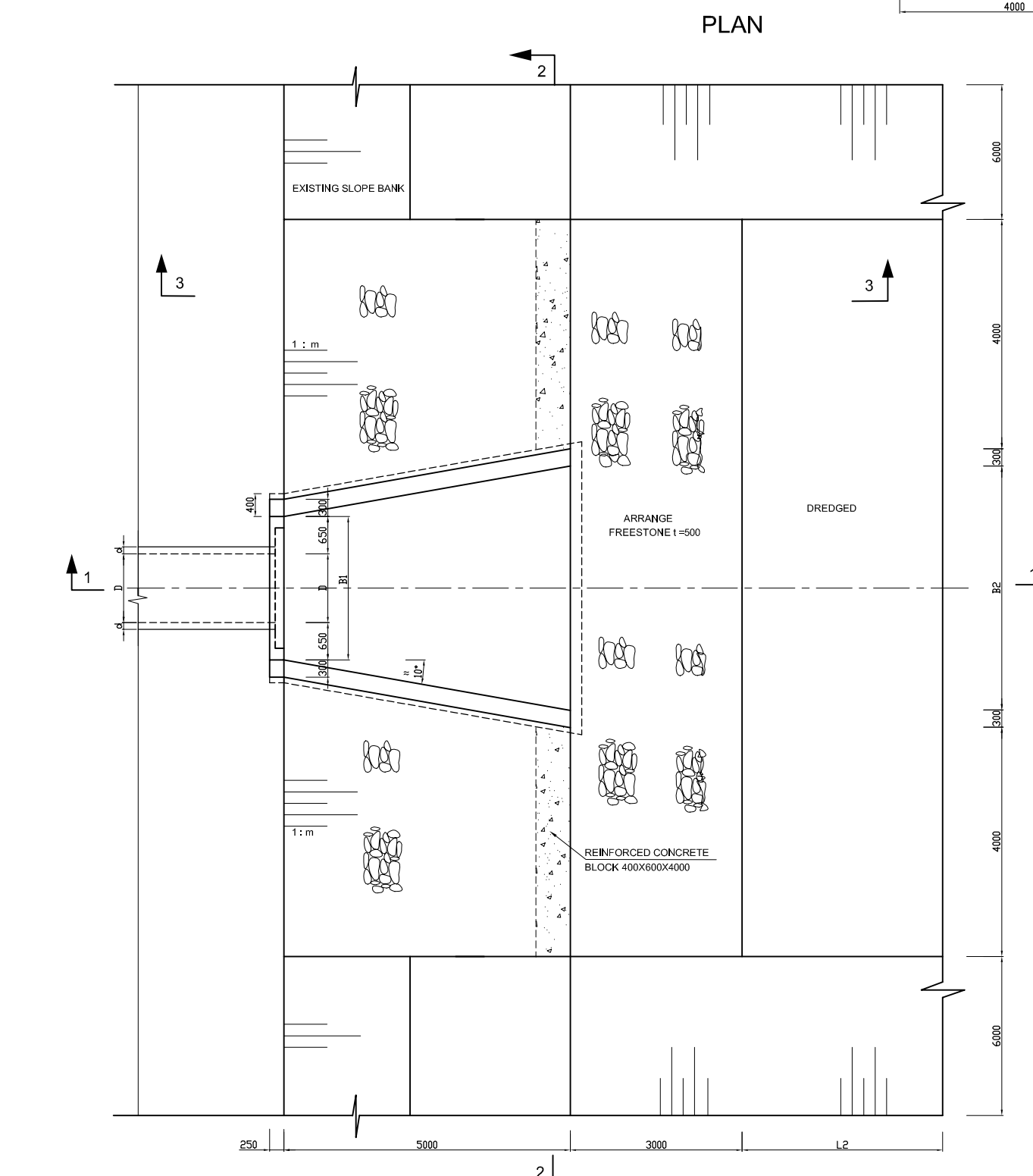
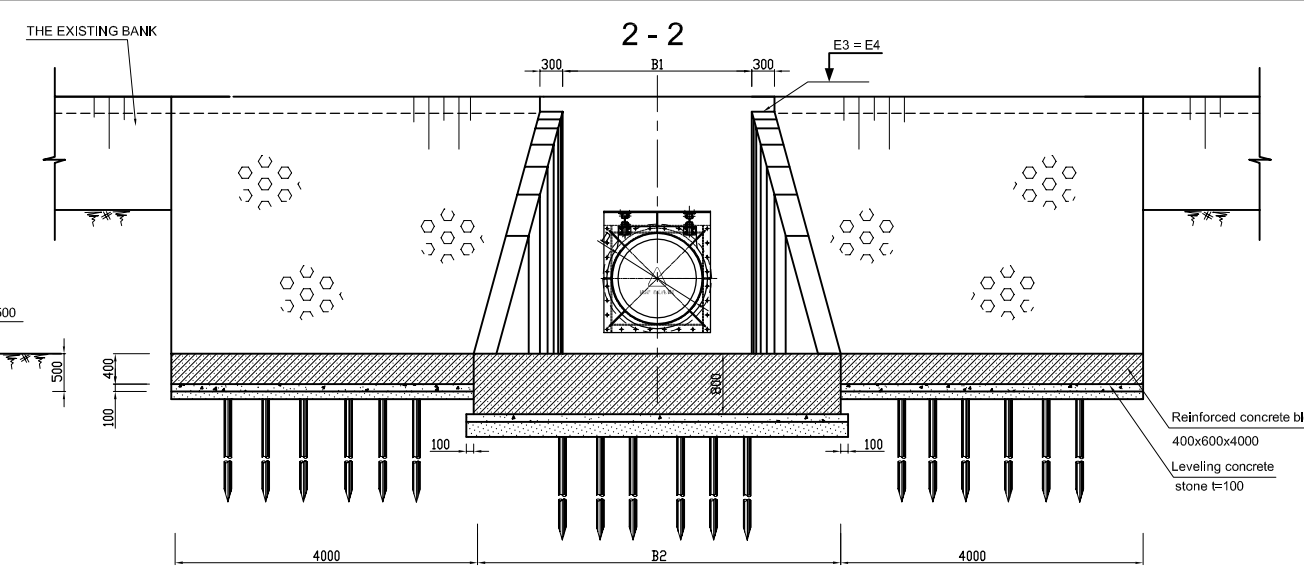
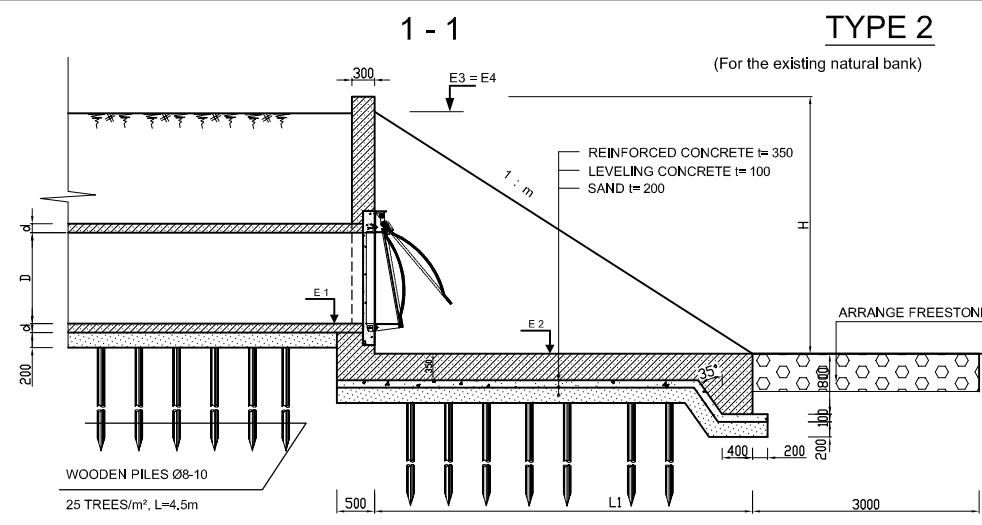

PLAN

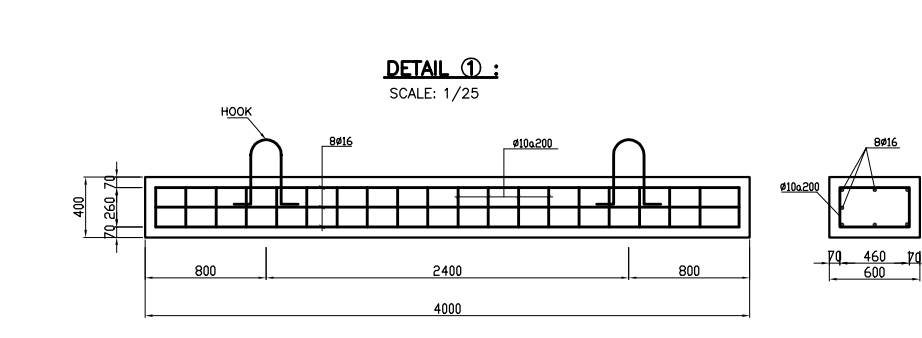
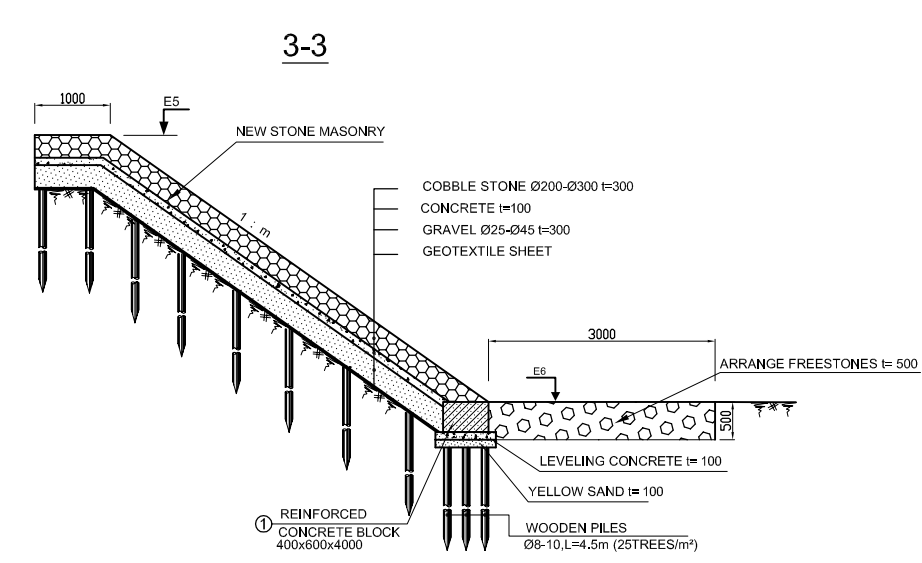

DETAIL 1 :
SCALE: 1/25

BEN ME COC 2

No	DIAMETER	POSITION	ELEVATION						m	H (m)	B1 (m)	B2 (m)	L1 (m)	L1 (m)
			E1	E2	E3	E4	E5	E6						
6	1000	S2-0+319	-0.746	-1.146	1.660	1.660	1.860	-1.146	1.5	3.00	2.30	3.90	4.50	6.50
7	1800	S1-0+921	-1.708	-2.108	1.300	1.300	1.500	-2.108	1.5	3.60	3.10	5.10	5.40	16.00
8	1500	S1-0+589	-1.242	-1.642	1.360	1.360	1.560	-1.642	1.5	3.20	2.80	4.40	4.80	17.50
9	1000	S1-0+282	-0.595	-0.995	0.930	0.930	1.130	-0.995	1.5	2.10	2.30	3.50	3.20	14.00

- LEGEND:**
- E1: INVERT ELEVATION OF SEWER PIPE
 - E2: ELEVATION OF OUTLET FLOOR
 - E3: TOP ELEVATION OF OUTLET VERTICAL WALL
 - E4: TOP ELEVATION OF OUTLET WING WALL
 - E5: TOP ELEVATION OF ADDITIONAL STONE MASONRY
 - E6: FOOT ELEVATION OF ADDITIONAL STONE MASONRY

NOTE:
DETAILS OF FLAP GATE REFERS TO PB - PDI - BMC1 - 405

NO.	DATE	DESCRIPTIONS	BY	APRO.

REVISIONS

PROJECT MANAGEMENT UNIT FOR
HO CHI MINH CITY
WATER ENVIRONMENT IMPROVEMENT

THE DETAILED DESIGN STUDY ON HO CHI MINH CITY
WATER ENVIRONMENT IMPROVEMENT PROJECT
IN THE SOCIALIST REPUBLIC OF VIET NAM

PACKAGE B
PUMP DRAINAGE IMPROVEMENT
BEN ME COC(2) AREA

TYPICAL PLAN AND SECTION
OF SEWER OUTLET (TYPE2)

SCALE : 1 : 50

JICA JAPAN INTERNATIONAL COOPERATION AGENCY (JICA)

PACIFIC CONSULTANTS INTERNATIONAL

DESIGNED _____ CHECKED _____

DATE : _____ DWG. No. PB - PDI - BMC2-239

TYPE 1 S = 1:40
Ø300 - Ø600

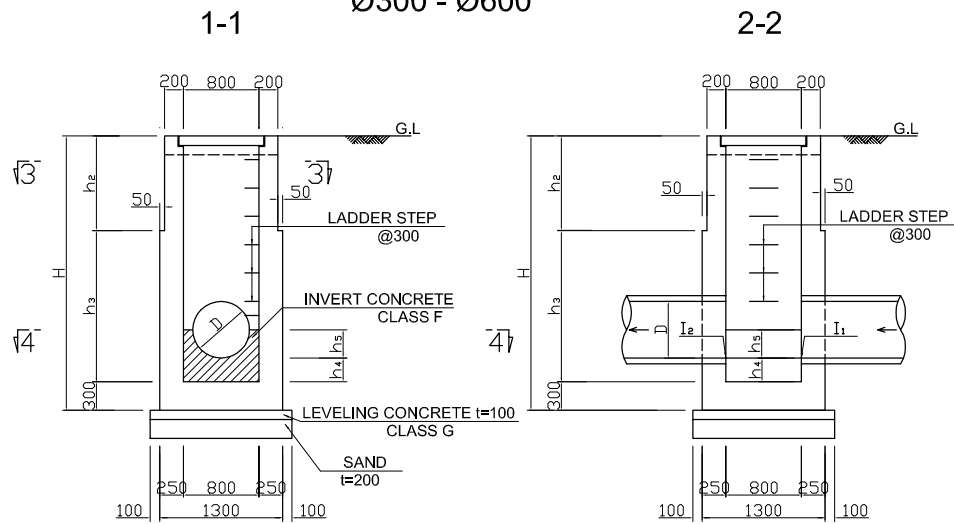

When H < 2500, h₂ = 0
When H ≥ 2500, h₂ = 1000

TYPE 2 S = 1:40
Ø700 - Ø1000

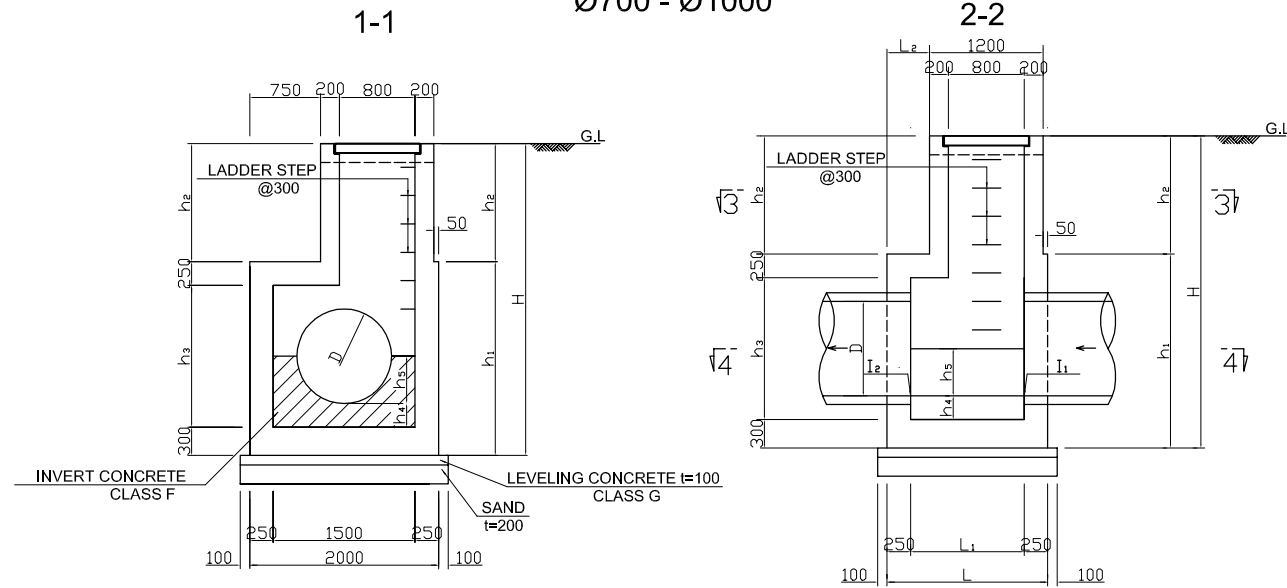

When H ≤ 2850, h₂ = 300
When H ≥ 2850, h₂ = 2000

3-3

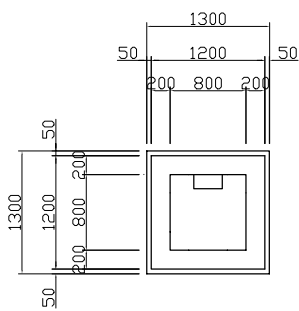

4-4

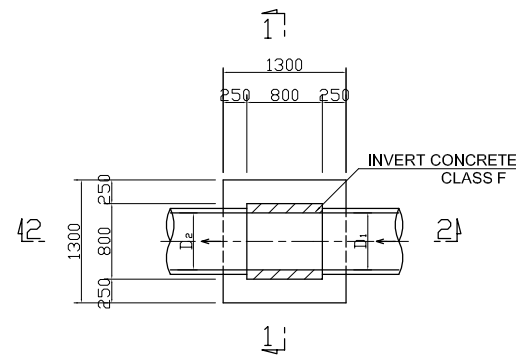

3-3

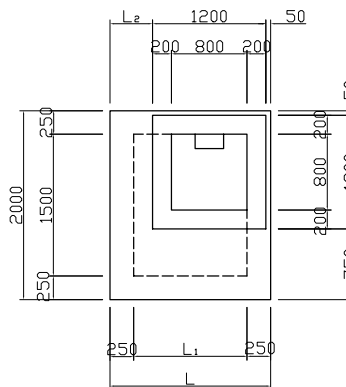

4-4

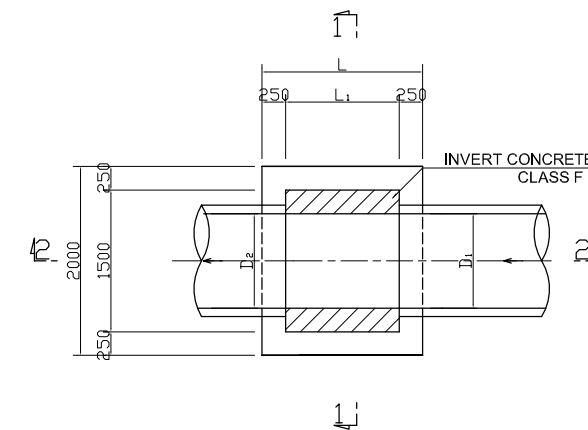

CONNECTION TYPE

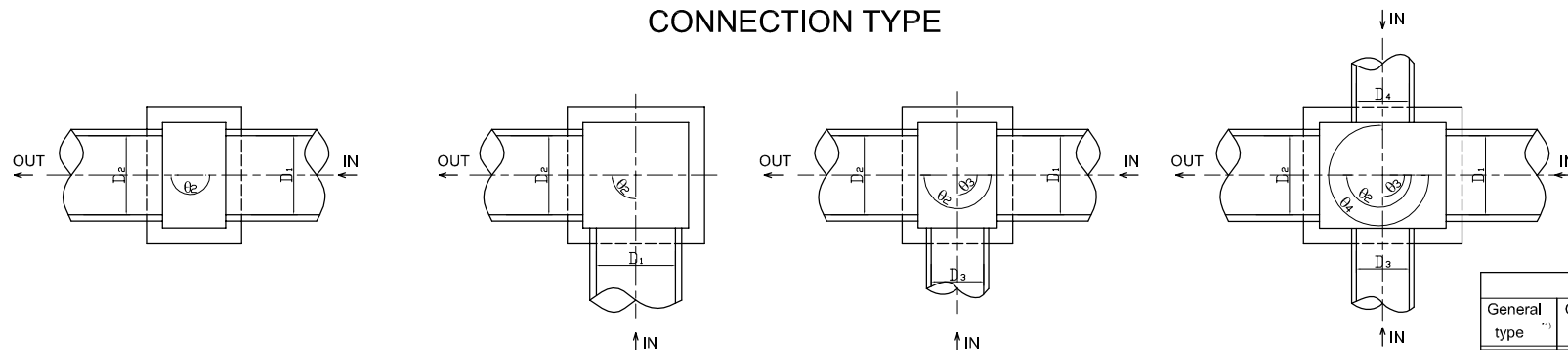

TYPE A

TYPE B

TYPE C

TYPE D

TYPE OF MANHOLE

General type ⁽¹⁾	Type of Manhole		Diameter (mm)		Dimension (m)			Number of Manhole	
	Connection type	Connection pipe ⁽²⁾	Main pipe (D ₁ , D ₂)	Connecting pipe (D ₁ , D ₂)	L	L ₁	L ₂		
1	A, B, C	-	Ø300-Ø600	Ø300-Ø600	-	-	-	3	
	A	-	Ø700-Ø1000	-	1,700	1,200	450	2	
B	-	-		2,000	1,500	750	3		
C	1	2		Ø300-Ø600	Ø300-Ø600	1,700	1,200	450	40
		Ø700-Ø1000		Ø700-Ø1000	2,000	1,500	750	0	
D	1	1	Ø300-Ø600	Ø300-Ø600	2,500	2,000	1,250	30	
		2	Ø700-Ø1000	Ø700-Ø1000	2,900	2,400	1,650	4	

This table is applied at a depth of up to 5.0m

Note:

*1) General type of Manhole type is categorized in diameter of Main pipe, D₁ and D₂.

*2) Connection pipe of Manhole type is categorized in a diameter of connection pipe.

NO.	DATE	DESCRIPTIONS	BY	APPRO.
-----	------	--------------	----	--------

REVISIONS

PROJECT MANAGEMENT UNIT FOR
HO CHI MINH CITY
WATER ENVIRONMENT IMPROVEMENT

THE DETAILED DESIGN ON HO CHI MINH CITY
WATER ENVIRONMENT IMPROVEMENT PROJECT
IN THE SOCIALIST REPUBLIC OF VIET NAM

PACKAGE B
PUMP DRAINAGE IMPROVEMENT
BEN ME COC (2) AREA
TYPICAL PLAN AND SECTION
OF MANHOLE (1)

SCALE : 1/40

JICA JAPAN INTERNATIONAL COOPERATION
AGENCY (JICA)

PACIFIC CONSULTANTS INTERNATIONAL

DESIGNED CHECKED

DATE : DWG. No. PB - PDI-BMC2 - 240

TYPE 3 S= 1:40
Ø1200 - Ø1500

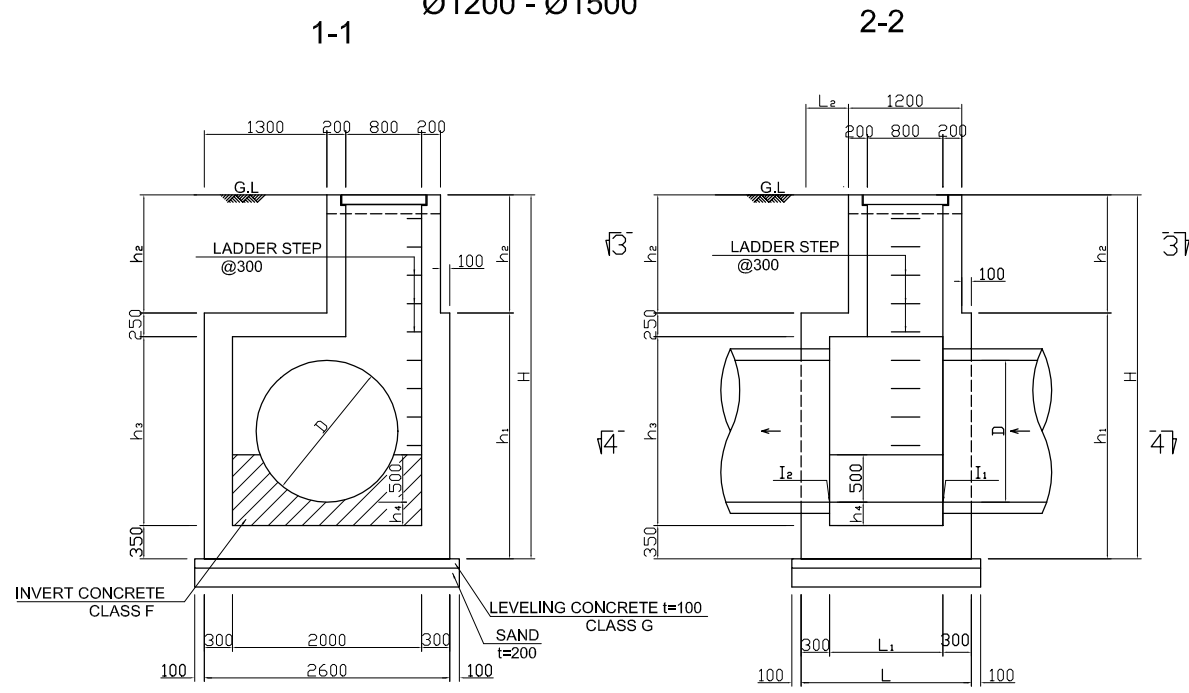

When $H \leq 2900$, $h_2 = 300$
When $H \geq 2900$, $h_2 = 2000$

TYPE 4 S= 1:40
Ø1600 - Ø2000

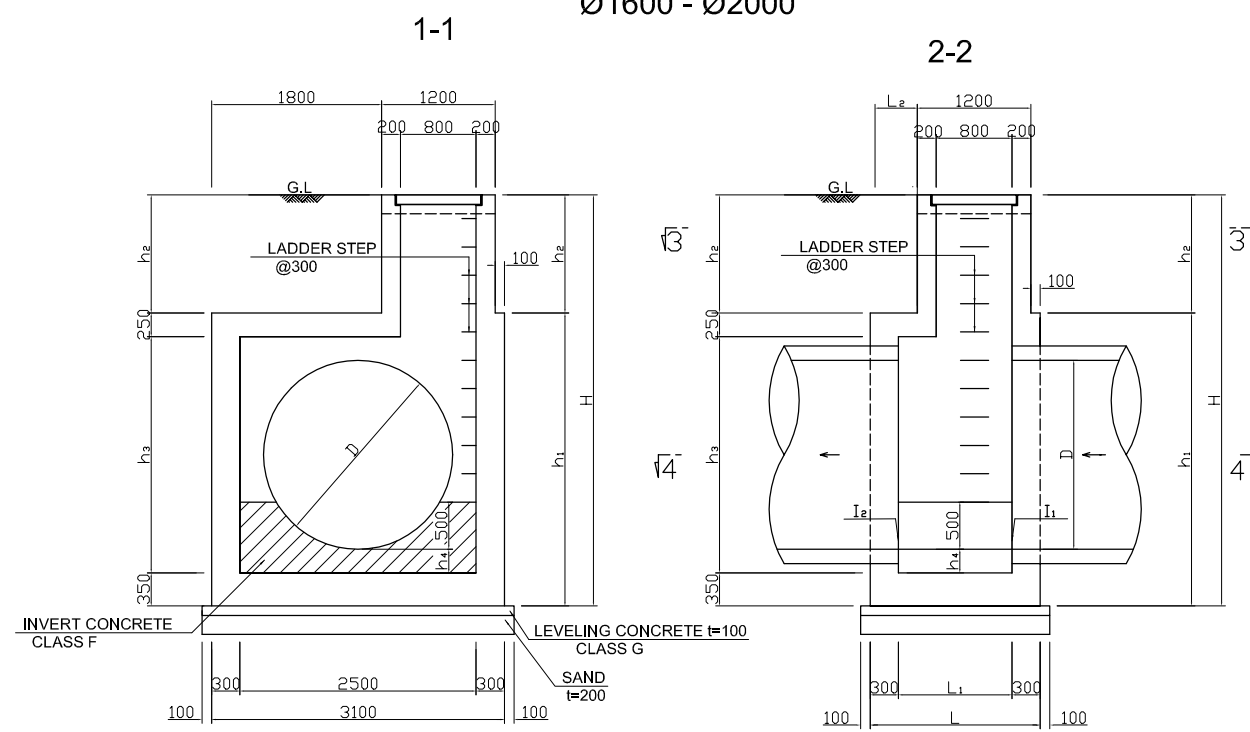

When $H \leq 3400$, $h_2 = 300$
When $H \geq 3400$, $h_2 = 2500$

3-3

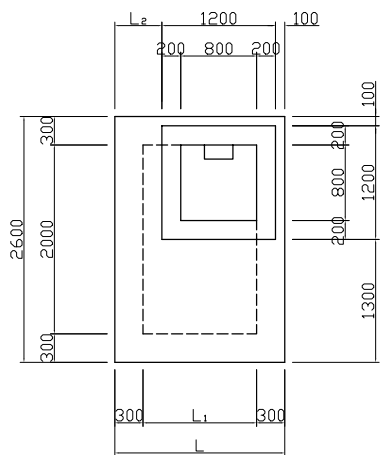

4-4

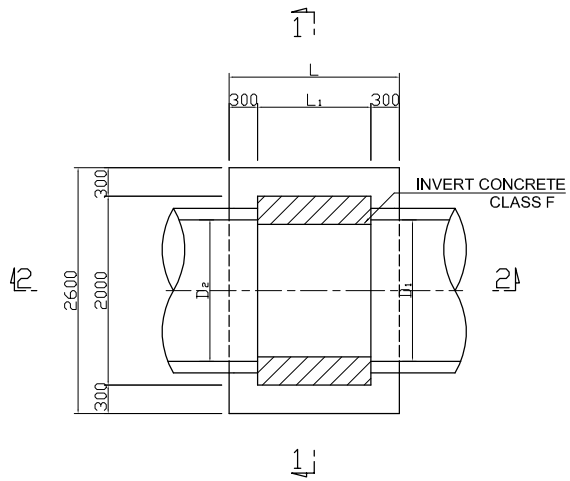

3-3

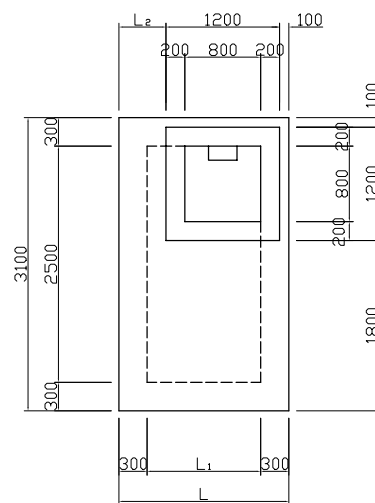

4-4

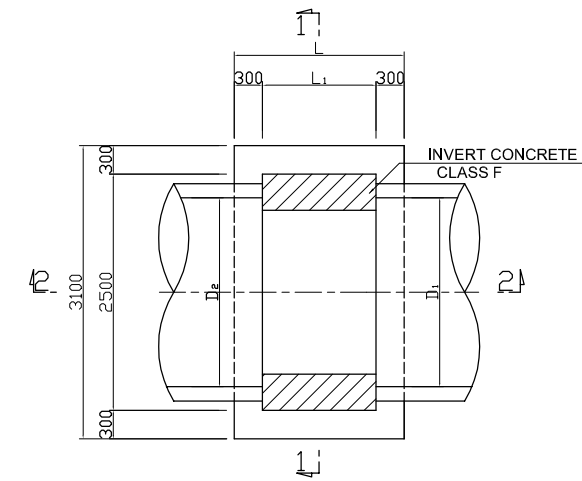

TYPE OF MANHOLE

General type ¹⁾	Type of Manhole		Diameter (mm)		Dimension (m)			Number of Manhole
	Connection type	Connection pipe ²⁾	Main pipe (D ₁ , D ₂)	Connecting pipe (D ₁ , D ₂)	L	L ₁	L ₂	
3	A	-	Ø1200-Ø1500	-	1,800	1,200	500	0
	B	-		-	2,600	2,000	1,300	0
	C	1		Ø300-Ø600	1,800	1,200	500	16
		2		Ø700-Ø1000	2,100	1,500	800	1
	D	1		Ø300-Ø600	2,600	2,000	1,300	20
		3		Ø1200-Ø1500	3,600	3,000	2,300	2
4	A	-	Ø1600-Ø2000	-	1,800	1,200	500	0
	B	-		-	3,100	2,500	1,800	0
	C	1		Ø300-Ø600	1,800	1,200	500	3
		2		Ø700-Ø1000	2,100	1,500	800	1
	3	1		Ø1200-Ø1500	2,600	2,000	1,300	1
		4		Ø1600-Ø2000	3,100	2,500	1,800	0
	D	1		Ø300-Ø600	2,600	2,000	1,300	0
		2		Ø700-Ø1000	3,000	2,400	1,700	0
		3		Ø1200-Ø1500	3,600	3,000	2,300	0
		4		Ø1600-Ø2000	4,100	3,500	2,800	1

This table is applied at a depth of up to 5.0m
Note:

- *1) General type of Manhole type is categorized in diameter of Main pipe, D₁ and D₂.
- *2) Connection pipe of Manhole type is categorized in a diameter of connection pipe.

CONNECTION TYPE

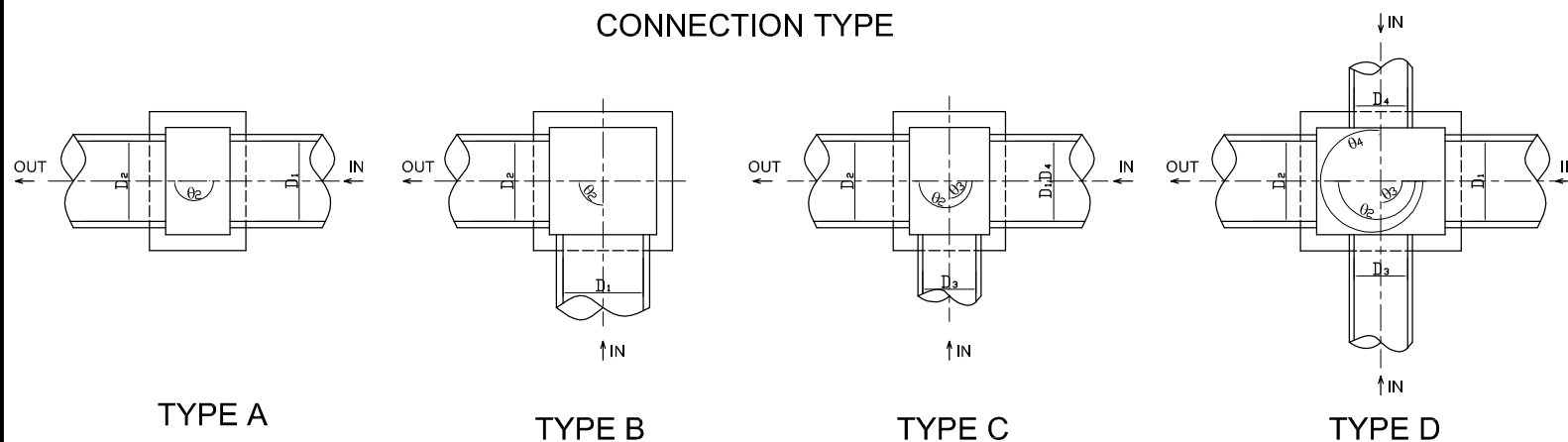

NO.	DATE	DESCRIPTIONS	BY	APRO.
REVISIONS				
PROJECT MANAGEMENT UNIT FOR HO CHI MINH CITY WATER ENVIRONMENT IMPROVEMENT				
THE DETAILED DESIGN ON HO CHI MINH CITY WATER ENVIRONMENT IMPROVEMENT PROJECT IN THE SOCIALIST REPUBLIC OF VIET NAM				
PACKAGE B PUMP DRAINAGE IMPROVEMENT BEN ME COC (2) AREA TYPICAL PLAN AND SECTION OF MANHOLE (2)				
SCALE : 1/40				
JAPAN INTERNATIONAL COOPERATION AGENCY (JICA)				
PACIFIC CONSULTANTS INTERNATIONAL				
DESIGNED		CHECKED		
DATE :		DWG. No. PB - PDI - BMC2 - 241		

WATER TRAP

SCALE : 1/10

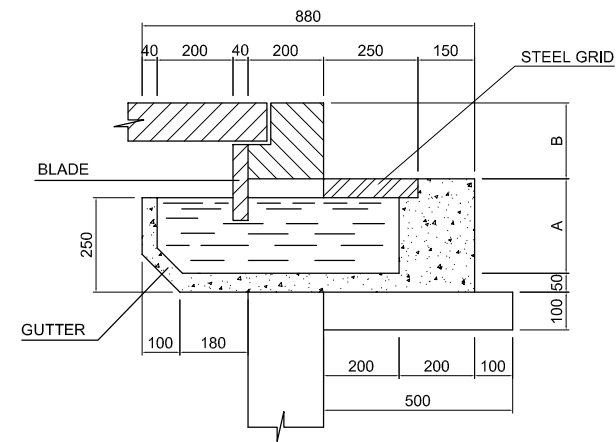

GUTTER
SCALE : 1/10

A-A
SCALE : 1/10

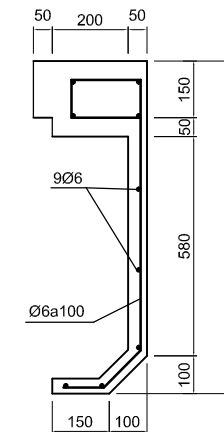
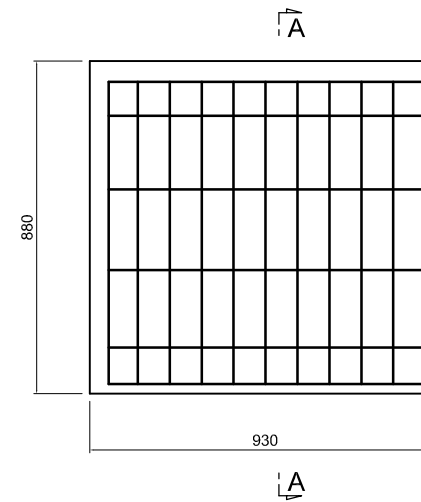

BLADE
SCALE : 1/10

B-B
SCALE : 1/10

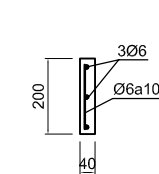
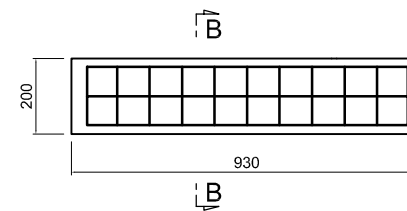

STEEL GRID
SCALE : 1/10

C-C
SCALE : 1/10

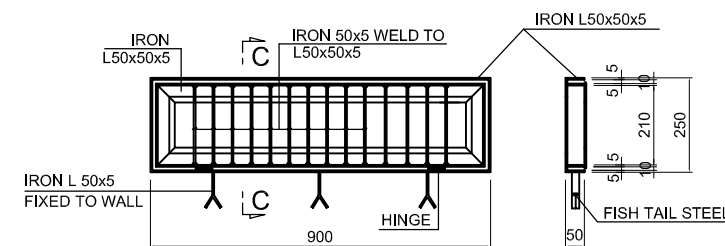

QUANTITY

- IRON V. 150x50x5	= 7.34 kg
- IRON 50x5	= 5.77 kg
WEIGHT: 23.11kg	

VOLUME TABLE

	GUTTER	BLADE
CONC. M200 (m³)	0.079	0.007
STEEL ROD Ø6 (Kg)	5.128	0.946

3-3

SCALE : 1/40

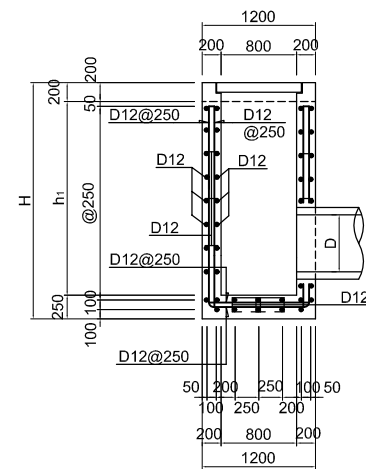

PLAN

SCALE : 1/40

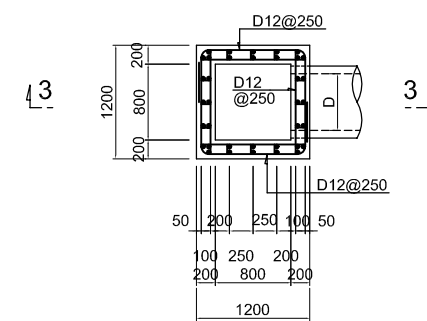

INLET TYPE

	A	B
I1	250	200
I2	400	0

1-1

SCALE : 1/40

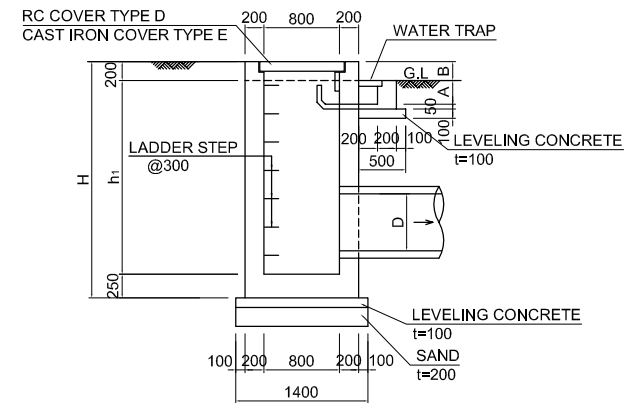

2-2

SCALE : 1/40

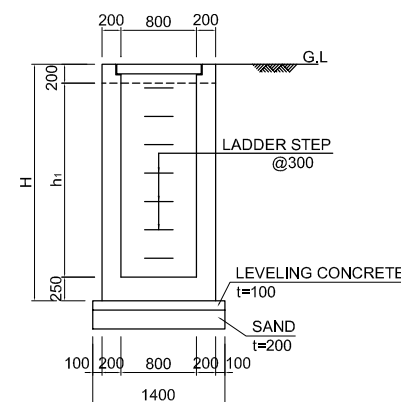

PLAN

SCALE : 1/40

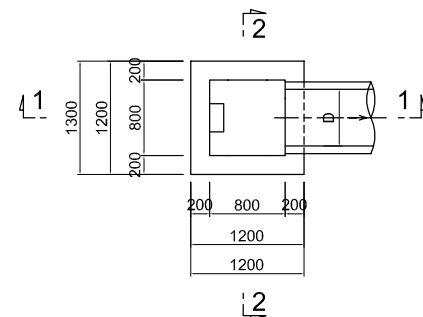

NO.	DATE	DESCRIPTIONS	BY	APRO.

REVISIONS

PROJECT MANAGEMENT UNIT FOR
HO CHI MINH CITY
WATER ENVIRONMENT IMPROVEMENT

THE DETAILED DESIGN ON HO CHI MINH CITY
WATER ENVIRONMENT IMPROVEMENT PROJECT
IN THE SOCIALIST REPUBLIC OF VIET NAM

PACKAGE B
PUMP DRAINAGE IMPROVEMENT
THANH DA AREA

TYPICAL PLAN, SECTION AND
BAR ARRANGEMENT OF INLET PIT

SCALE : AS SHOWN

JICA JAPAN INTERNATIONAL COOPERATION
AGENCY (JICA)

PACIFIC CONSULTANTS INTERNATIONAL

DESIGNED CHECKED

DATE : DWG. No. PB-PDI-BMC2-242